

Altivar HVAC ATH230

Variable Speed Drives for Asynchronous and Synchronous Motors

Installation Manual

JPS43203.01
11/2025



Legal Information

The information provided in this document contains general descriptions, technical characteristics and/or recommendations related to products/solutions.

This document is not intended as a substitute for a detailed study or operational and site-specific development or schematic plan. It is not to be used for determining suitability or reliability of the products/solutions for specific user applications. It is the duty of any such user to perform or have any professional expert of its choice (integrator, specifier or the like) perform the appropriate and comprehensive risk analysis, evaluation and testing of the products/solutions with respect to the relevant specific application or use thereof.

The Schneider Electric brand and any trademarks of Schneider Electric SE and its subsidiaries referred to in this document are the property of Schneider Electric SE or its subsidiaries. All other brands may be trademarks of their respective owner.

This document and its content are protected under applicable copyright laws and provided for informative use only. No part of this document may be reproduced or transmitted in any form or by any means (electronic, mechanical, photocopying, recording, or otherwise), for any purpose, without the prior written permission of Schneider Electric.

Schneider Electric does not grant any right or license for commercial use of the document or its content, except for a non-exclusive and personal license to consult it on an "as is" basis.

Schneider Electric reserves the right to make changes or updates with respect to or in the content of this document or the format thereof, at any time without notice.

To the extent permitted by applicable law, no responsibility or liability is assumed by Schneider Electric and its subsidiaries for any errors or omissions in the informational content of this document, as well as any non-intended use or misuse of the content thereof.

Table of Contents

Safety Information.....	5
About the document	7
Introduction	15
Verifying the Absence of Voltage.....	16
Drive Overview.....	18
Altivar Efficiency Calculator	23
Steps for setting up the drive	24
Preliminary Instructions.....	25
Technical Data.....	26
Environmental Conditions	27
Dimensions and Weights.....	29
Electrical Data - Drive Ratings	38
Electrical Data - Upstream Protective Device	42
Upstream Protective Device – Introduction.....	43
Prospective Short-Circuit Current.....	45
IEC Type Circuit-Breaker — with enclosure.....	47
IEC Type Circuit-Breaker — wall mounted	50
IEC Fuses — with enclosure.....	52
IEC Fuses — wall mounted.....	54
UL Circuit-Breakers and Fuses	58
Drive Mounting	62
Mounting Conditions	63
Power Dissipated For Enclosed Drives and Required Air Flow	68
Derating Curves	70
Derating Curves — ATH230●●●M2	71
Derating Curves — ATH230●●●M3	72
Derating Curves — ATH230●●●N4	75
Derating Curves — ATH230●●●S6	81
Checking mechanical installation before wiring	84
Drive wiring	85
Wiring Instructions.....	86
Cable Length Instructions.....	90
General Wiring Diagrams	92
Relay Contacts Wiring	95
Output Relay with Inductive AC Loads.....	96
Output Relay with Inductive DC loads.....	97
Operation on an IT or Corner Grounded System.....	99
Disconnecting the Built-in EMC Filter	100
Sink / Source Switch Configuration	105
Characteristics of the Power Part Terminals.....	107
Wiring the Power Part	114
EMC plate assembly fitting	127
Electromagnetic Compatibility	130
Control Terminals Electrical Data	133
Arrangement and Characteristics of Control Block Terminals and Communication and I/O Ports.....	136
Wiring The Control Part.....	138

Checking Installation	141
Maintenance	143
Scheduled Servicing	144
Long-term Storage.....	146
Decommissioning	147
Additional Support	148
Glossary	149

Safety Information

Important Information

Read these instructions carefully, and look at the equipment to become familiar with the device before trying to install, operate, service, or maintain it. The following special messages may appear throughout this documentation or on the equipment to warn of potential hazards or to call attention to information that clarifies or simplifies a procedure.



The addition of this symbol to a “Danger” or “Warning” safety label indicates that an electrical hazard exists which will result in personal injury if the instructions are not followed.



This is the safety alert symbol. It is used to alert you to potential personal injury hazards. Obey all safety messages that follow this symbol to avoid possible injury or death.

DANGER

DANGER indicates a hazardous situation which, if not avoided, **will result in death or serious injury**.

WARNING

WARNING indicates a hazardous situation which, if not avoided, **could result in death or serious injury**.

CAUTION

CAUTION indicates a hazardous situation which, if not avoided, **could result in minor or moderate injury**.

NOTICE

NOTICE is used to address practices not related to physical injury.

Please Note

Electrical equipment should be installed, operated, serviced, and maintained only by qualified personnel. No responsibility is assumed by Schneider Electric for any consequences arising out of the use of this material.

A qualified person is one who has skills and knowledge related to the construction and operation of electrical equipment and its installation, and has received safety training to recognize and avoid the hazards involved.

Qualification of Personnel

Only appropriately trained persons who are familiar with and understand the contents of this manual and all other pertinent product documentation are authorized to work on and with this product. In addition, these persons must have received safety training to recognize and avoid hazards involved. These persons must have sufficient technical training, knowledge and experience and be able to foresee and detect potential hazards that may be caused by using the product, by changing the settings and by the mechanical, electrical and electronic equipment of the entire system in which the product is used. All persons working on and with the product must be fully familiar with all applicable standards, directives, and accident prevention regulations when performing such work.

Intended Use

This product is intended for industrial use according to this manual.

The product may only be used in compliance with all applicable safety standard and local regulations and directives, the specified requirements and the technical data. The product must be installed outside the hazardous ATEX zone. Prior to using the product, you must perform a risk assessment in view of the planned application. Based on the results, the appropriate safety measures must be implemented. Since the product is used as a component in an entire system, you must ensure the safety of persons by means of the design of this entire system (for example, machine design). Any use other than the use explicitly permitted is prohibited and can result in hazards.

About the document

Document Scope

The purpose of this document is:

- to give you mechanical and electrical information related to the Altivar HVAC ATH230 drives,
- to show you how to install and wire this drive.

Validity Note

Original instructions and information given in the present document have been written in English (before optional translation).

This documentation is valid for the Altivar HVAC ATH230 drives.

The characteristics of the products described in this document are intended to match the characteristics that are available on www.se.com. As part of our corporate strategy for constant improvement, we may revise the content over time to enhance clarity and accuracy. If you see a difference between the characteristics in this document and the characteristics on www.se.com, consider www.se.com to contain the latest information.

Product Related Information

Read and understand these instructions before performing any procedure with this device.

DANGER

HAZARD OF ELECTRIC SHOCK, EXPLOSION OR ARC FLASH

- Only appropriately trained persons who are familiar with and fully understand the contents of the present manual and all other pertinent product documentation and who have received all necessary training to recognize and avoid hazards involved are authorized to work on and with this device system.
- Installation, adjustment, repair and maintenance must be performed by qualified personnel.
- Verify compliance with all local and national electrical code requirements as well as all other applicable regulations with respect to grounding of all equipment.
- Only use properly rated, electrically insulated tools and measuring equipment.
- Do not touch unshielded components or terminals with voltage present.
- Prior to performing any type of work on the device system, block the motor shaft to prevent rotation.
- Insulate both ends of unused conductors of the motor cable.
- Do not short across the DC bus terminals or the DC bus capacitors or the braking resistor terminals.

Failure to follow these instructions will result in death or serious injury.

DANGER

HAZARD OF ELECTRIC SHOCK, EXPLOSION, OR ARC FLASH

Before performing work on the device system:

- Disconnect all power, including external control power that may be present. Take into account that the circuit breaker or main switch does not de-energize all circuits.
- Place a “Do Not Turn On” label on all power switches related to the device system.
- Lock all power switches in the open position.
- Wait 15 minutes to allow the DC bus capacitors to discharge.
- Verify the absence of voltage. (1)

Before applying voltage to the device system:

- Verify that the work has been completed and that the entire installation cannot cause hazards.
- If the mains input terminals and the motor output terminals have been grounded and short-circuited, remove the ground and the short circuits on the mains input terminals and the motor output terminals.
- Verify proper grounding of all equipment.
- Verify that all protective equipment such as covers, doors, grids is installed and/or closed.

Failure to follow these instructions will result in death or serious injury.

(1) Refer to the Verify the Absence of Voltage section, page 16.

Damaged products or accessories may cause electric shock or unanticipated equipment operation.

⚡ ⚠ DANGER

ELECTRIC SHOCK OR UNANTICIPATED EQUIPMENT OPERATION

Do not use damaged products or accessories.

Failure to follow these instructions will result in death or serious injury.

Contact your local Schneider Electric sales office if you detect any damage whatsoever.

This equipment has been designed to operate outside of any hazardous location. Only install this equipment in zones known to be free of a hazardous atmosphere.

⚠ DANGER

POTENTIAL FOR EXPLOSION

Install and use this equipment in non-hazardous locations only.

Failure to follow these instructions will result in death or serious injury.

Your application consists of a whole range of different interrelated mechanical, electrical, and electronic components, the device being just one part of the application. The device by itself is neither intended to nor capable of providing the entire functionality to meet all safety-related requirements that apply to your application. Depending on the application and the corresponding risk assessment to be conducted by you, a whole variety of additional equipment is required such as, but not limited to, external encoders, external brakes, external monitoring devices, guards, etc.

As a designer/manufacturer of machines, you must be familiar with and observe all standards that apply to your machine. You must conduct a risk assessment and determine the appropriate Performance Level (PL) and/or Safety Integrity Level (SIL) and design and build your machine in compliance with all applicable standards. In doing so, you must consider the interrelation of all components of the machine. In addition, you must provide instructions for use that enable the user of your machine to perform any type of work on and with the machine such as operation and maintenance in a safe manner.

The present document assumes that you are fully aware of all normative standards and requirements that apply to your application. Since the device cannot provide all safety-related functionality for your entire application, you must ensure that the required Performance Level and/or Safety Integrity Level is reached by installing all necessary additional equipment.

▲ WARNING

INSUFFICIENT PERFORMANCE LEVEL/SAFETY INTEGRITY LEVEL AND/OR UNINTENDED EQUIPMENT OPERATION

- Conduct a risk assessment according to EN ISO 12100 and all other standards that apply to your application.
- Use redundant components and/or control paths for all critical control functions identified in your risk assessment.
- Implement all monitoring functions required to avoid any type of hazard identified in your risk assessment, for example, slipping or falling loads.
- Verify that the service life of all individual components used in your application is sufficient for the intended service life of your overall application.
- Perform extensive commissioning tests for all potential error situations to verify the effectiveness of the safety-related functions and monitoring functions implemented, for example, but not limited to, speed monitoring by means of encoders, short circuit monitoring for all connected equipment, correct operation of brakes and guards.
- Perform extensive commissioning tests for all potential error situations to verify that the load can be brought to a safe stop under all conditions.

Failure to follow these instructions can result in death, serious injury, or equipment damage.

Product may perform unexpected movements because of incorrect wiring, incorrect settings, incorrect data or other errors.

▲ WARNING

UNANTICIPATED EQUIPMENT OPERATION

- Carefully install the wiring in accordance with the EMC requirements.
- Do not operate the product with unknown or unsuitable settings or data.
- Perform a comprehensive commissioning test.

Failure to follow these instructions can result in death, serious injury, or equipment damage.

⚠ WARNING

LOSS OF CONTROL

- The designer of any control scheme must consider the potential failure modes of control paths and, for critical control functions, provide a means to achieve a safe state during and after a path failure. Examples of critical control functions are emergency stop, overtravel stop, power outage and restart.
- Separate or redundant control paths must be provided for critical control functions.
- System control paths may include communication links. Consideration must be given to the implications of unanticipated transmission delays or failures of the link.
- Observe all accident prevention regulations and local safety guidelines (1).
- Each implementation of the product must be individually and thoroughly tested for proper operation before being placed into service.

Failure to follow these instructions can result in death, serious injury, or equipment damage.

(1) For USA: Additional information, refer to NEMA ICS 1.1 (latest edition), Safety Guidelines for the Application, Installation, and Maintenance of Solid State Control and to NEMA ICS 7.1 (latest edition), Safety Standards for Construction and Guide for Selection, Installation and Operation of Adjustable-Speed Drive Systems.

The temperature of the products described in this manual may exceed 80°C (176°F) during operation.

⚠ WARNING

HOT SURFACES

- Ensure that any contact with hot surfaces is avoided.
- Do not allow flammable or heat-sensitive parts in the immediate vicinity of hot surfaces.
- Verify that the product has sufficiently cooled down before handling it.
- Verify that the heat dissipation is sufficient by performing a test run under maximum load conditions.

Failure to follow these instructions can result in death, serious injury, or equipment damage.

NOTICE

DESTRUCTION DUE TO INCORRECT MAINS VOLTAGE

Before switching on and configuring the product, verify that it is approved for the mains voltage.

Failure to follow these instructions can result in equipment damage.

General Cybersecurity Information

In recent years, the growing number of networked machines and production plants has seen a corresponding increase in the potential for cyber threats, such as unauthorized access, data breaches, and operational disruptions. You must, therefore, consider all possible cybersecurity measures to help protect assets and systems against such threats.

To help keep your Schneider Electric products secure and protected, it is in your best interest to implement the cybersecurity best practices as described in the [Cybersecurity Best Practices](#) document.

Schneider Electric provides additional information and assistance:

- Subscribe to the Schneider Electric security newsletter.
- Visit the [Cybersecurity Support Portal](#) web page to:
 - Find Security Notifications.
 - Report vulnerabilities and incidents.
- Visit the [Schneider Electric Cybersecurity and Data Protection Posture](#) web page to:
 - Access the cybersecurity posture.
 - Learn more about cybersecurity in the cybersecurity academy.
 - Explore the cybersecurity services from Schneider Electric.

Environmental Data

The Environmental Data Program is a framework for how we measure, categorize, and compare the environmental attributes and footprint of our products.

Using a rigorous, fact-based methodology, the program provides environmental data from across the product lifecycle.

Five data categories across the product lifecycle



Use Better: How sustainable a product is, including environmental footprint, materials and substances, packaging, and energy efficiency.

Use Longer: How a product's life time can be effectively extended in terms of reparability and updatability.

Use Again: How a product can be reused, from dismantling and remanufacturing to recyclability and manufacturer take back.

With this transparent, verified data, customers and partners are empowered to make conscious environmental choices and accurately evaluate and report on sustainability performance.

All our hardware offers have an associated environmental data available on [se.com](#) product pages.

Refer to [Environmental Data Program](#) for more information.

Related Documents

Use your tablet or your PC to quickly access detailed and comprehensive information on all our products on [www.se.com](#).

The internet site provides the information you need for products and solutions:

- The whole catalog for detailed characteristics and selection guides,
- The CAD files to help design your installation, available in over 20 different file formats,
- All software and firmware to maintain your installation up to date,

- A large quantity of White Papers, Environment documents, Application solutions, Specifications... to gain a better understanding of our electrical systems and equipment or automation,
- And finally all the User Guides related to your drive, listed below:

Title of Documentation	Reference Number
Catalog: Altivar Building ATH200	DIA2ED2250901EN (English) DIA2ED2250901FR (French)
ATH200 Getting Started	JPS43191 (English), JPS43192 (French), JPS43193 (German), JPS43194 (Spanish) JPS43198 (Italian), JPS43199 (Chinese), JPS43197 (Portuguese), JPS43195 (Turkish)
ATH200 Getting Started Annex (SCCR)	JPS43196 (English)
ATH200 Installation manual	JPS43203 (English), JPS43204 (French), JPS43202 (German), JPS43201 (Spanish), JPS43200 (Italian), JPS43208 (Chinese), JPS43205 (Portuguese), JPS43209 (Turkish)
ATH200 Programming manual	JPS43207 (English), JPS43206 (French), JPS43212 (German), JPS43211 (Spanish), JPS43210 (Italian), JPS43213 (Chinese), JPS43214 (Portuguese), JPS43215 (Turkish)
ATH200 ATEX manual	JPS43218 (English)
ATH200 Modbus manual	JPS43217 (English)
ATH200 BACnet manual	JPS43216 (English)
ATH200 Communication Parameters	JPS43219 (English)
ATH200 Safety Functions manual	JPS43226 (English), JPS43227 (French), JPS43229 (German), JPS43233 (Spanish), JPS43231 (Italian), JPS43232 (Chinese)
SoMove: FDT	SoMove_FDT (English, French, German, Spanish, Italian, Chinese)
ATH200: DTM	ATH200 DTM Library EN (English – to be installed first) ATH200 DTM Lang IT (Italian) ATH200 DTM Lang FR (French) ATH200 DTM Lang DE (German) ATH200 DTM Lang SP (Spanish) ATH200 DTM Lang CN (Chinese)
ATV320 ATV Logic manual	NVE71954 (English), NVE71955 (French), NVE71957 (German), NVE71959 (Spanish), NVE71958 (Italian), NVE71960 (Chinese)
Recommended Cybersecurity Best Practices	CS-Best-Practices-2019-340 (English)

To find documents online, visit the Schneider Electric download center (www.se.com/ww/en/download/).

Information on Non-Inclusive or Insensitive Terminology

As a responsible, inclusive company, Schneider Electric is constantly updating its communications and products that contain non-inclusive or insensitive terminology. However, despite these efforts, our content may still contain terms that are deemed inappropriate by some customers.

Electronic product data sheet



Terminology used in this document

The technical terms, terminology, and the corresponding descriptions in this manual normally use the terms or definitions in the relevant standards.

Among others, these standards include:

- ISO 13849: The Foundation of Functional Safety in the Machinery
- IEC 60204-1: Safety of machinery - Electrical equipment of machines – Part 1: General requirements.
- IEC 61158 series: Industrial communication networks - Fieldbus specifications
- IEC 61508 Ed.2 series: Functional safety of electrical/electronic/programmable electronic safety-related.
- IEC 61784 series: Industrial communication networks - Profiles.
- IEC 61800 series: Adjustable speed electrical power drive systems.
- IEC 62443: Security for industrial automation and control systems.

In the area of drive systems this includes, but is not limited to, terms such as **error**, **error message**, **failure**, **fault**, **fault reset**, **protection**, **safe state**, **safety function**, **warning**, **warning message**, and so on.

In addition, the term **zone of operation** is used in conjunction with the description of specific hazards, and is defined as it is for a **hazard zone** or **danger zone** in the EC Machinery Directive (2006/42/EC) and in ISO 12100-1.

Contact us

Select your country on www.se.com/contact.

Schneider Electric Industries SAS

Head Office

35, rue Joseph Monier

92500 Rueil-Malmaison

France

Introduction

What's in This Part

Verifying the Absence of Voltage	16
Drive Overview	18
Altivar Efficiency Calculator	23
Steps for setting up the drive	24
Preliminary Instructions	25

Verifying the Absence of Voltage

Instructions

The DC bus voltage level is determined by measuring the voltage between the DC bus terminals PA/+ and PC/-.

The location of the DC bus terminals depends on the drive model.

Identify your drive model by referring to the nameplate of the drive.

Then, refer to the chapter *Wiring the Power Part*, page 114 for the location of the DC bus terminals PA/+ and PC/-.

Read and understand these instructions before performing any procedure with this device.

DANGER

HAZARD OF ELECTRIC SHOCK, EXPLOSION OR ARC FLASH

- Only appropriately trained persons who are familiar with and fully understand the contents of the present manual and all other pertinent product documentation and who have received all necessary training to recognize and avoid hazards involved are authorized to work on and with this device system.
- Installation, adjustment, repair and maintenance must be performed by qualified personnel.
- Verify compliance with all local and national electrical code requirements as well as all other applicable regulations with respect to grounding of all equipment.
- Only use properly rated, electrically insulated tools and measuring equipment.
- Do not touch unshielded components or terminals with voltage present.
- Prior to performing any type of work on the device system, block the motor shaft to prevent rotation.
- Insulate both ends of unused conductors of the motor cable.
- Do not short across the DC bus terminals or the DC bus capacitors or the braking resistor terminals.

Failure to follow these instructions will result in death or serious injury.

⚠️⚠️ DANGER

HAZARD OF ELECTRIC SHOCK, EXPLOSION, OR ARC FLASH

Before performing work on the device system:

- Disconnect all power, including external control power that may be present. Take into account that the circuit breaker or main switch does not de-energize all circuits.
- Place a “Do Not Turn On” label on all power switches related to the device system.
- Lock all power switches in the open position.
- Wait 15 minutes to allow the DC bus capacitors to discharge.
- Verify the absence of voltage. (1)

Before applying voltage to the device system:

- Verify that the work has been completed and that the entire installation cannot cause hazards.
- If the mains input terminals and the motor output terminals have been grounded and short-circuited, remove the ground and the short circuits on the mains input terminals and the motor output terminals.
- Verify proper grounding of all equipment.
- Verify that all protective equipment such as covers, doors, grids is installed and/or closed.

Failure to follow these instructions will result in death or serious injury.

(1) Refer to the procedure in the present document, page 17.

Procedure

Perform the following actions to verify the absence of voltage

Step	Action
1	Measure the voltage on the DC bus between the DC bus terminals (PA/+ and PC/-) using a properly rated voltmeter to verify that the voltage is less than 42 Vdc
2	If the DC bus capacitors do not discharge properly, contact your local Schneider Electric representative. Do not repair or operate the product.
3	Verify that no other voltage is present in the drive system.





Drive Overview



About The Drive Frame Sizes

The drive frame size first digits 1, 2, 3, 4, 5 and 6 are related to the drive footprint.

NOTE: For a given frame size, there may be different depth values, details are visible in the Dimensions and Weight section, page 29.

ATH230 Drives – Open Type (IP20)

Frame size 1		Frame size 2			
					
1-phase 200...240 V, 0.37...0.75 kW, 0.5...1 HP	3-phase 200...240 V, 0.37...0.75 kW, 0.5...1 HP	1-phase 200...240 V, 1.1...2.2 kW, 1.5...2.95 HP	3-phase 200...240 V, 1.1...2.2 kW, 1.5...2.95 HP	3-phase 380...500 V, 0.55...1.5 kW, 0.75...2 HP	3-phase 525...600 V, 1.5 kW, 2 HP
ATH230U04M2, ATH230U06M2, ATH230U07M2	ATH230U04M3, ATH230U06M3, ATH230U07M3	ATH230U11M2, ATH230U15M2, ATH230U22M2	ATH230U11M3, ATH230U15M3, ATH230U22M3	ATH230U06N4, ATH230U07N4, ATH230U11N4, ATH230U15N4	ATH230U15S6
Frame size 3			Frame size 4		
					
3-phase 200...240 V, 3 kW and 4 kW, 4 and 5 HP	3-phase 380...500 V, 2.2 and 4 kW, 2.95 and 5 HP	3-phase 525...600 V, 2.2 and 4 kW, 2.95 and 5 HP	3-phase 200...240 V, 5.5 kW and 7.5 kW, 7.35 and 10 HP	3-phase 380...500 V, 5.5 kW...7.5 kW, 7.5...10 HP	3-phase 525...600 V, 5.5 kW...7.5 kW, 7.5...10 HP
ATH230U30M3, ATH230U40M3	ATH230U22N4, ATH230U30N4, ATH230U40N4	ATH230U22S6, ATH230U40S6	ATH230U55M3, ATH230U75M3	ATH230U55N4, ATH230U75N4	ATH230U55S6, ATH230U75S6

Frame size 5		Frame size 6	
			
3-phase 200...240 V, 11 kW and 15 kW, 15 and 20 HP	3-phase 380...500 V, 11 kW and 15 kW, 15 and 20 HP	3-phase 525...600 V, 11 kW and 15 kW, 15 and 20 HP	3-phase 380...500 V, 18.5 kW and 22 kW, 25 and 29.5 HP
ATH230D11M3 and ATH230D15M3	ATH230D11N4 and ATH230D15N4	ATH230D11S6 and ATH230D15S6	ATH230D18N4 and ATH230D22N4

Communication

Integrated: Single port compatible with Modbus Serial line and BACnet MSTP.

Optional: BACnet IP module VW3A3726.

Catalog Number Description

	ATH	230	U	55	N4
Product range					
ATH	Altivar HVAC				
Product type					
230	IP20 product				
Factor for power rating					
U	power x 0.1				
D	power x 1				
Power rating [kW]	4, 6, 7, 11, 15, 18, 22, 30, 40, 55, 75				
Power part supply					
M2	Single phase, 200 Vac (200...240 Vac)				
M3	3-phase, 200 Vac (200...240 Vac)				
N4	3-phase, 400 Vac (380...500 Vac)				
S6	3-phase, 600 Vac (525...600 Vac)				

Nameplate example

The nameplate contains the following data:

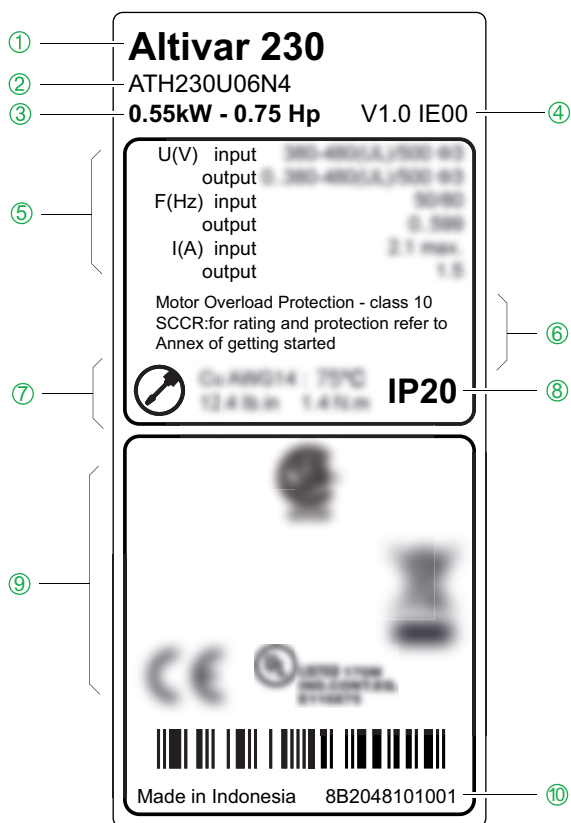

- | | | | |
|------------------|---|--------------------------------|-----------------------------|
| ① Product type | ④ Firmware version | ⑦ Power part cable information | ⑩ Serial number information |
| ② Catalog number | ⑤ Power part supply | ⑧ Degree of protection | |
| ③ Power rating | ⑥ Fuses and overload protection information | ⑨ Certifications | |

Manufacturing Date

Use the serial number ⑩ of the drive to retrieve its manufacturing date.

The four digits after the first 2 characters of the serial number provide respectively the year and the week of manufacture.

In the nameplate example illustrated above **8B2048101001** the manufacturing date is year 2020, week 48.

Accessories and Options

⚡⚠ DANGER

ELECTRIC SHOCK CAUSED BY INSUFFICIENT GROUNDING

- Verify compliance with all local and national electrical code requirements as well as all other applicable regulations with respect to grounding of the entire device.
- Ground the device before applying voltage.
- The cross section of the protective ground conductor must comply with the applicable standards.
- Do not use conduits as protective ground conductors; use a protective ground conductor inside the conduit.
- Do not consider cable shields to be protective ground conductors.

Failure to follow these instructions will result in death or serious injury.

The drives are designed to take numerous accessories and options to increase their functionality. For a detailed description and catalog numbers, refer to the Catalog on www.se.com

All accessories and options come with an instruction sheet to help installation and commissioning. Therefore you will only find here a short product description.

Option module adapter

The **VW3A3600** mechanical adapter for communication modules can be used to make more communication buses and networks available by inserting the corresponding module directly into the adapter.

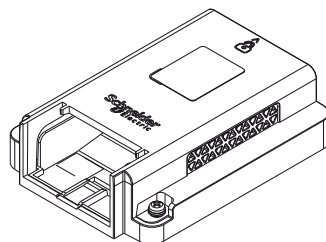

Display Terminal

- Remote Graphic display Terminal
- Door mounting kit
- Remote LED display terminal

Drive Mounting and Wiring

- EMC plate
- Kit for conformity to UL Type 1

Spare Parts

- Fan replacement kit
- Removable control terminal block

Connection and Communication

- Speed monitoring card
- Fieldbus module: BACnet IP

Altivar Efficiency Calculator

Description

This tool calculates the level of energy efficiency of your variable speed drive according to the Ecodesign standard EN/IEC 61800-9-2.

In 2 specific cases :

- **Drive Efficiency** (CDM Complete Drive Module) :
Performance is determined according to 8 operating points taking into account torque and speed.
- **System Efficiency** (PDS Power Drive System) :
This includes the efficiency of the variable speed drive and its motor.
Performance is determined according to 8 operating points taking into account torque and speed.

Easy access to the tool

The tool is available at the address: altivar-efficiency-calculator.se.app

Steps for setting up the drive

① Receive and inspect the drive controller

- Verify that the supply mains is compatible with the power part supply range of the drive.
- Check that the catalog number printed on the label is the same as that on the purchase order.
- Remove the drive from its packaging and check that it has not been damaged.

② Verify the supply mains

- Verify that the supply mains is compatible with the power part supply range of the drive.

③ Mount the drive

- Mount the drive in accordance with the instructions in this document.
- Install the transformer(s), if any.
- Install any internal and external options.

④ Wire the drive

- Connect the motor, ensuring that its connections correspond to the voltage.
- Connect the supply mains, after making sure that the power is off.
- Connect the control.

⑤ Programming

Refer to the Programming manual, page 13.

Preliminary Instructions

Inspecting the product

Damaged products or accessories may cause electric shock or unanticipated equipment operation.

DANGER

ELECTRIC SHOCK OR UNANTICIPATED EQUIPMENT OPERATION

Do not use damaged products or accessories.

Failure to follow these instructions will result in death or serious injury.

Contact your local Schneider Electric sales office if you detect any damage whatsoever.

Step	Action
1	Verify that the catalog number printed on the nameplate, page 21 corresponds to the purchase order.
2	Before performing any installation work, inspect the product for visible damage.

Technical Data

What's in This Part

Environmental Conditions	27
Dimensions and Weights	29
Electrical Data - Drive Ratings	38
Electrical Data - Upstream Protective Device.....	42

Environmental Conditions

Withstand to harsh environments

- Chemical class 3C3 conforming to IEC/EN 60721-3-3
- Mechanical class 3S2 conforming to IEC/EN 60721-3-3

Temperature Conditions

Ambient Air Temperature

For	Drive	Temperature		Comments
Storage	All	°C	–25...70	–
		°F	–13...158	
Operation	ATH230	°C	–10...50	Without derating
		°F	14...122	
		°C	50...60	With derating
		°F	122...158	

Relative Humidity

Without dripping water and without condensation: 5...95%

Operating Altitude

Operating altitude according to supply voltage

Operating Altitude	Supply Mains	Supply Mains Type			Derating
		TT/TN	IT	Corner Grounded	
> 1,000 m (3,300 ft)	200 / 240 V 1-phase	✓	✓	✓	w/o
	200 / 240 V 3-phase	✓	✓	✓	w/o
	380 / 500 V 3-phase	✓	✓	✓	w/o
	525 / 600 V 3-phase	✓	✓	✓	w/o
1,000...2,000 m (3,300...6,600 ft)	200 / 240 V 1-phase	✓	✓	✓	w
	200 / 240 V 3-phase	✓	✓	✓	w
	380 / 500 V 3-phase	✓	✓	✓	w
	525 / 600 V 3-phase	✓	✓	✓	w
2,000...3,000 m (6,600...9,900 ft)	200 / 240 V 1-phase	✓	✓	–	w
	200 / 240 V 3-phase	✓	✓	–	w
	380 / 500 V 3-phase	✓	✓	–	w
	525 / 600 V 3-phase	–	–	–	N/A
✓ Yes – No N/A Not applicable w Operation possible with derating of the nominal current of the drive by 1% for each additional 100 m w/o Operation possible without derating					

Pollution Degree and Degree of Protection

Drive	Pollution Degree	Degree of Protection
ATH230	2	IP20

Dimensions and Weights

About the drawings

All drawings CAD files can be downloaded from www.se.com

NOTE: When designing your installation, please take into account that all depth values should be increased by 40 mm (1.58 in) in case of using the additional slot option. This option module takes place between the Graphic display Terminal and the drive, causing the depth value to be increased. It enables to connect an option module.

Frame Size 1

ATH230U04M•

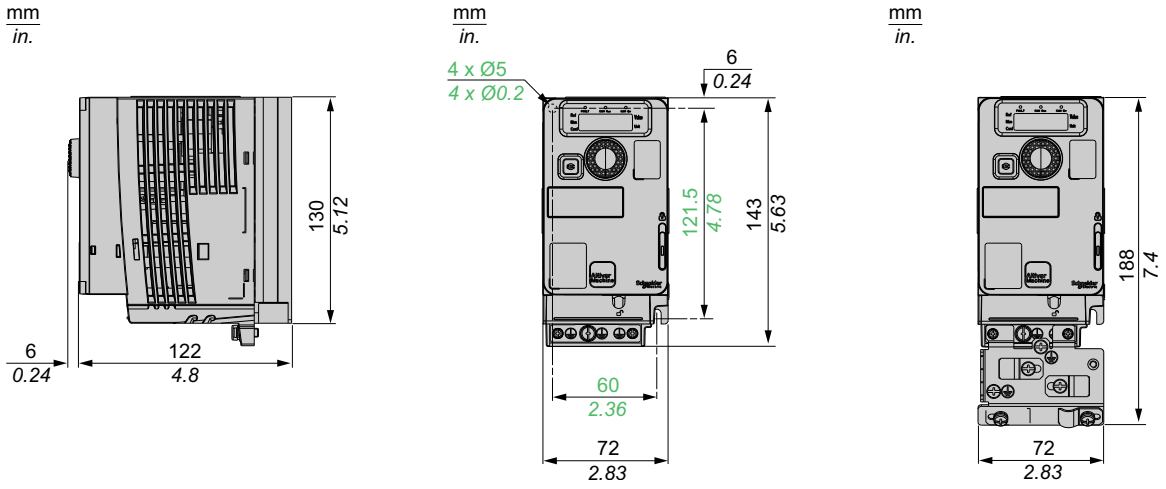

ATH230U06M2, ATH230U07M2

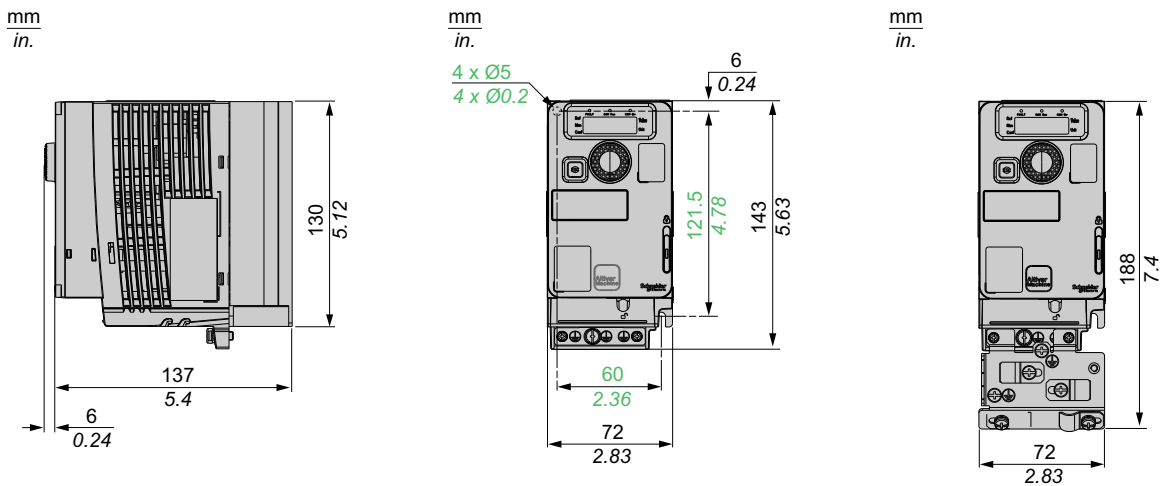

ATH230U06M3, ATH230U07M3

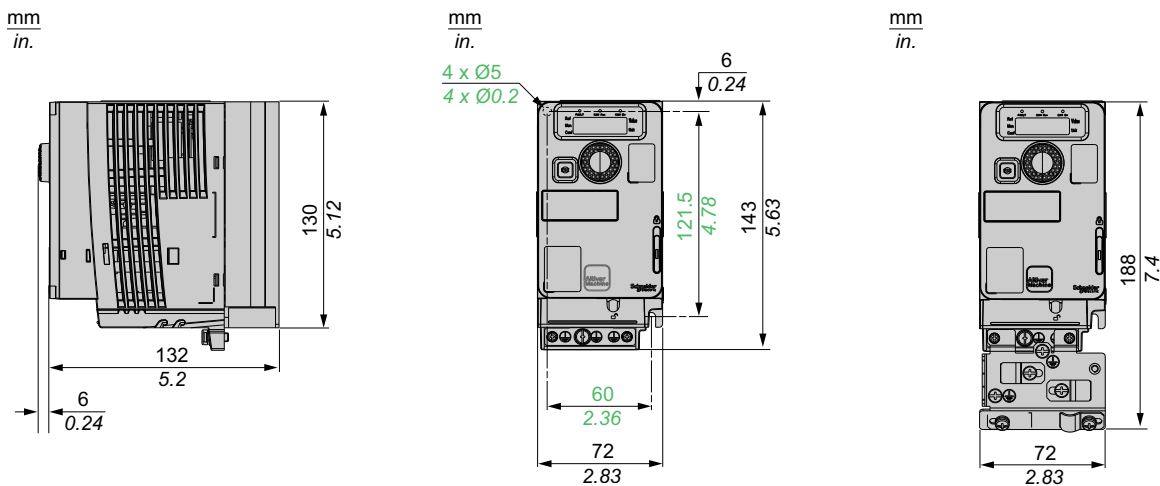

Weights

Catalog Number	Weight in kg (lb)
ATH230U04M3	0,9
ATH230U06M3, •U07M3, •U04M2	1,0
ATH230U06M2, •U07M2	1,1

Frame Size 2

ATH230U11M2...ATH230U22M2, ATH230U06N4...ATH230U15N4, ATH230U15S6

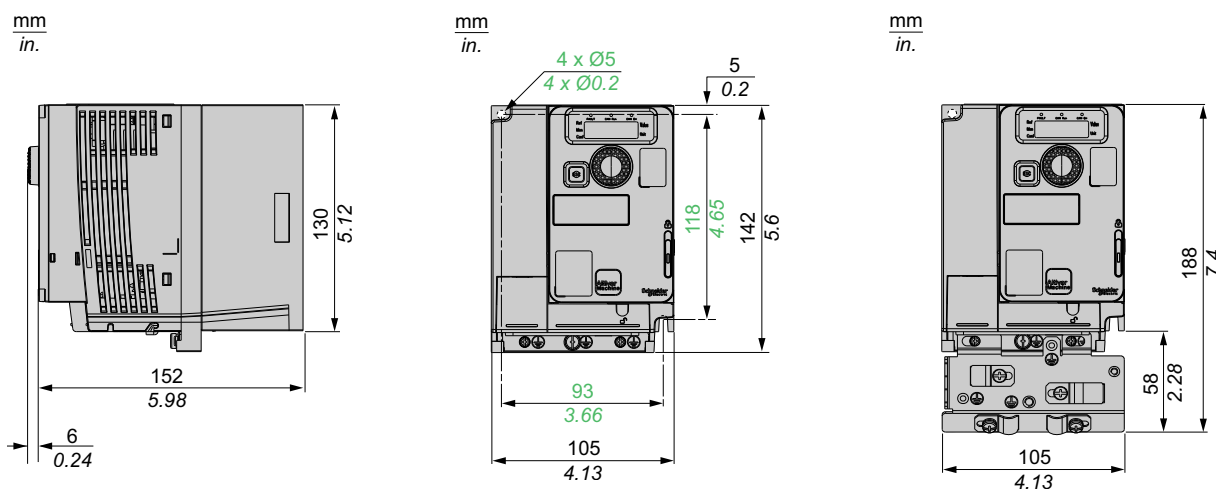

ATH230U11M3...ATH230U22M3

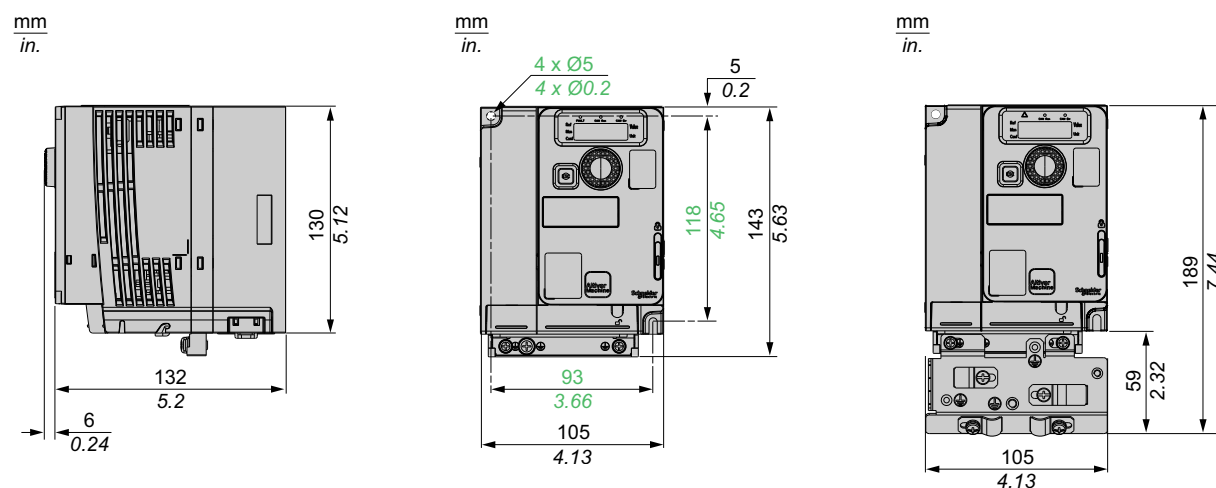

Weights

Catalog Number	Weight in kg (lb)
ATH230U06N4, •U07N4	1,2
ATH230U11N4, •U15N4, •U15S6	1,3
ATH230U11M3, •U15M3, •U22M3	1,4
ATH230U11M2, •U15M2, •U22M2	1,6

Frame Size 3

ATH230U30M3, ATH230U40M3, ATH230U22N4, ATH230U30N4, ATH230U40N4, ATH230U22S6, ATH230U40S6

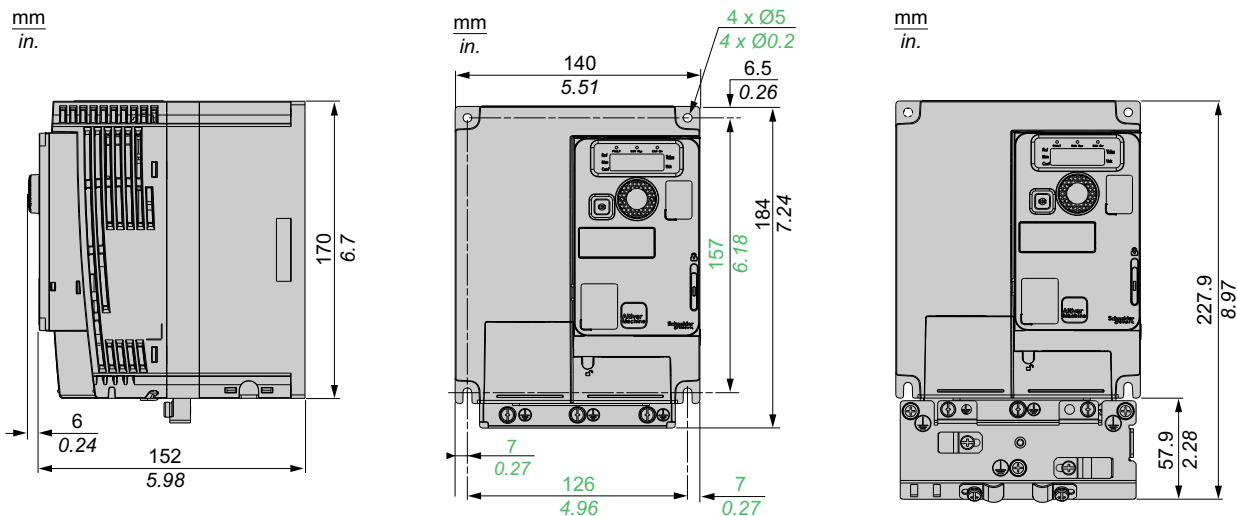

Weights

Catalog Number	Weight in kg (lb)
ATH230U22N4	2,1
ATH230U30N4	2,1
ATH230U40N4, •U30M3, •U40M3	2,2
ATH230U22S6	2,0
ATH230U40S6	2,5

Frame Size 4

ATH230U55••, ATH230U75••

mm
in.

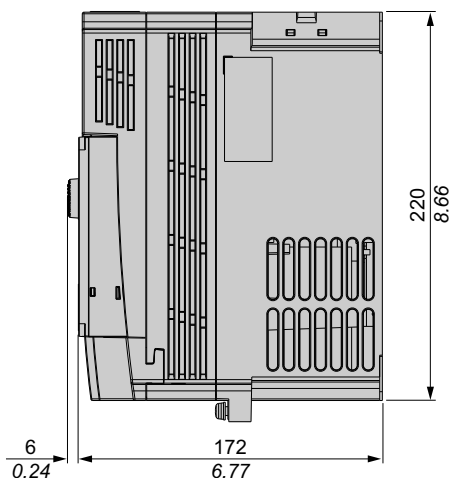

mm
in.

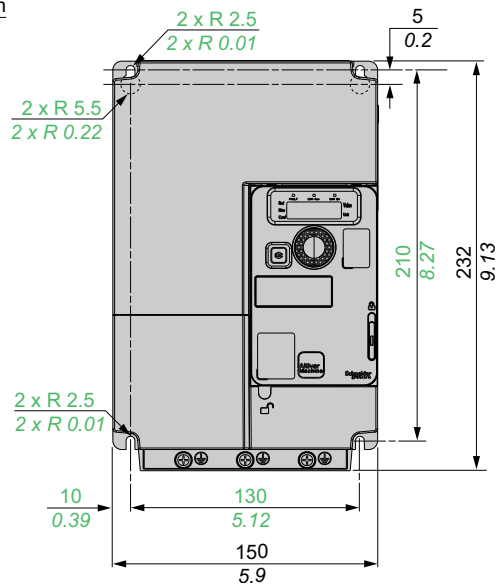

mm
in.

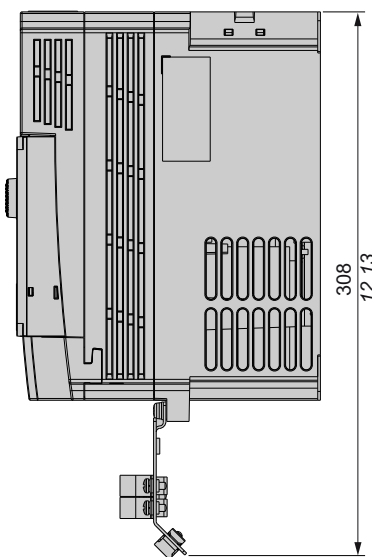

mm
in.

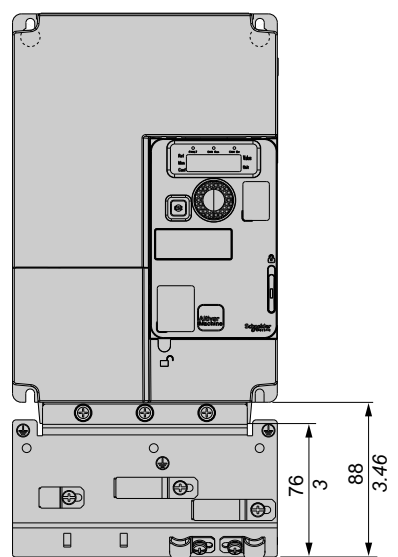

Weights

Catalog Number	Weight in kg (lb)
ATH230U55••	3,5
ATH230U75S6	
ATH230U75M3	3,6
ATH230U75N4	

Frame Size 5

ATH230D11••, ATH230D15••

mm
in.

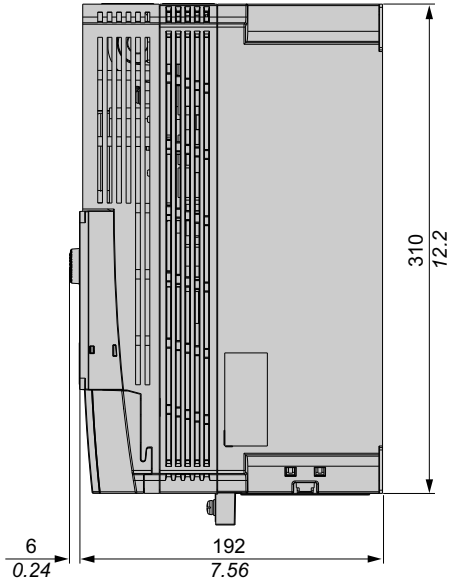

mm
in.

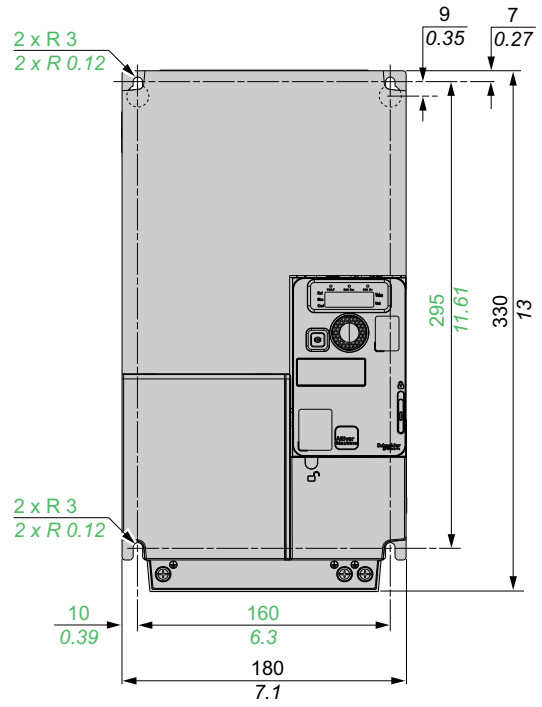

mm
in.

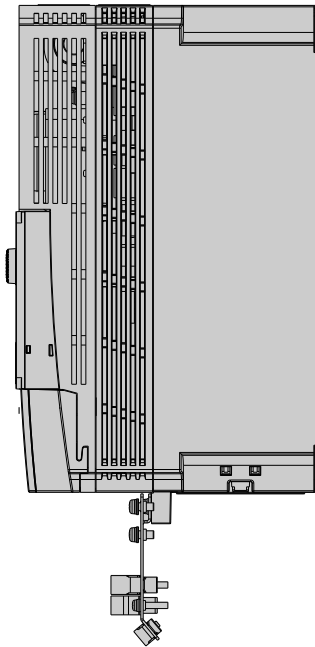

mm
in.

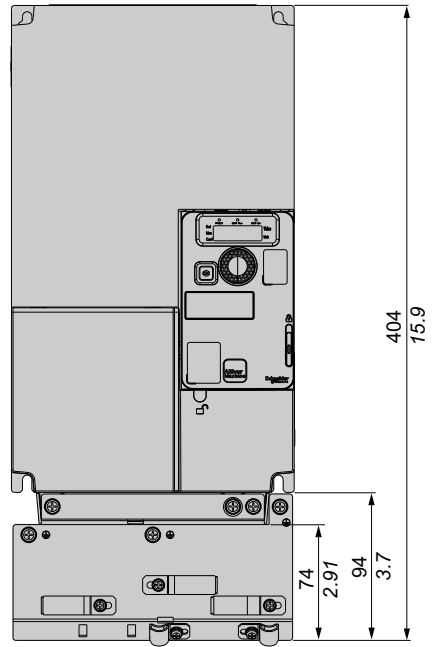

Weights

Catalog Number	Weight in kg (lb)
ATH230D11M3 ATH230D11N4	6,8
ATH230D15M3 ATH230D15N4	6,9
ATH230D11S6, •D15S6	6,5

Frame Size 6

ATH230D18N4, ATH230D22N4

mm
in.

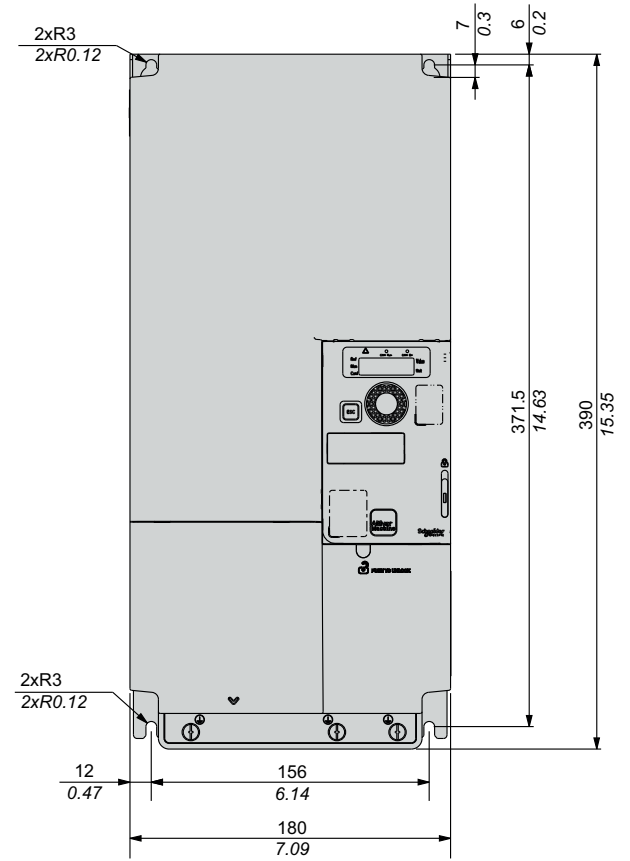
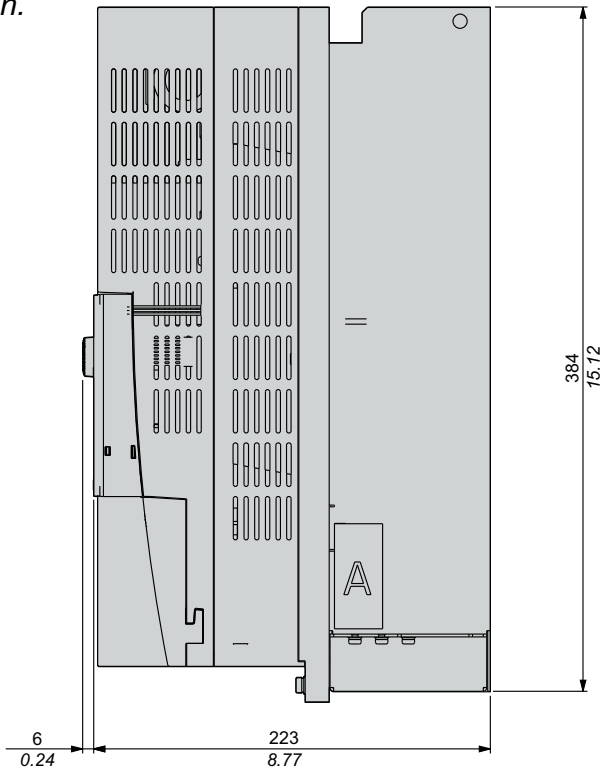

mm
in.

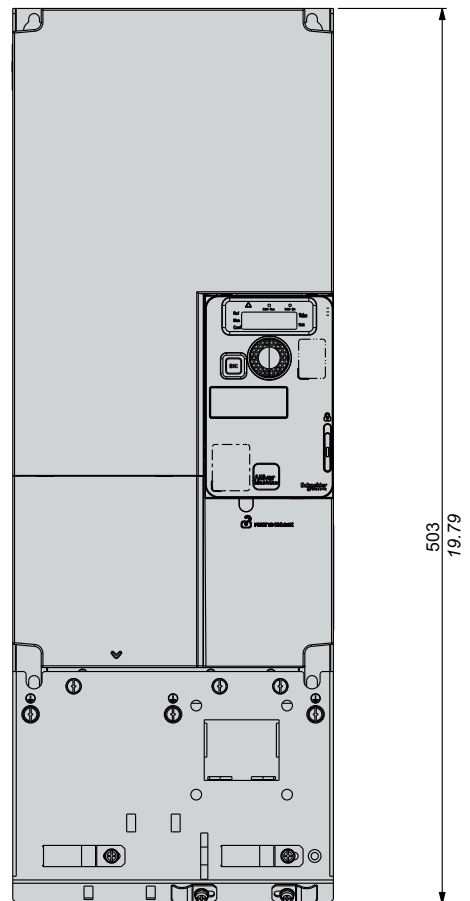
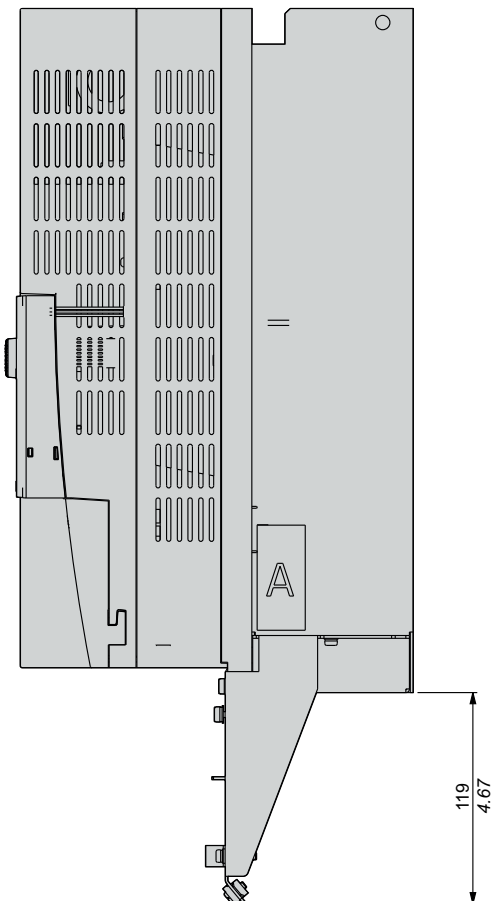

Weights

Catalog Number	Weight in kg (lb)
ATH230D18N4	9.5
ATH230D22N4	

Electrical Data - Drive Ratings

Single phase supply voltage: 200 (-15%)...240 (+10%)V 50/60 Hz

Power and Current Ratings

Catalog Number	Nominal Power (1)		Power Part Supply				Drive (output)	
			Max. Input Current		Apparent Power	Max. Inrush Current (2)	Nominal Current (1)	Max. Transient current (1) (3)
	At 200 Vac	At 240 Vac	A	A				
	kW	HP	A	A	kVA	A	A	A
ATH230U04M2	0.37	0.5	5.9	4.9	1.2	9.6	3.3	3.6
ATH230U06M2	0.55	0.75	7.8	6.6	1.6	9.6	3.7	4.1
ATH230U07M2	0.75	1.0	10.0	8.4	2.0	9.6	4.8	5.3
ATH230U11M2	1.1	1.5	13.7	11.5	2.8	19.1	6.9	7.6
ATH230U15M2	1.5	2.0	17.8	14.9	3.6	19.1	8.0	8.8
ATH230U22M2	2.2	3.0	24.0	20.2	4.8	19.1	11.0	12.1

(1) The switching frequency is adjustable from 2...16 kHz, rated value: 4 kHz.

For operation at switching frequencies higher than the rated value, Derating must be applied to the drive (output) current, page 70. In this case, switching frequency can be reduced if an excessive temperature rise occurs.

(2) Peak current when power is switched On for the maximum supply mains voltage.

(3) The drive is designed to run up to 60 s at 110% of nominal current.

3-phase supply voltage: 200 (-15%)...240 (+10%)V 50/60 Hz

Power and Current Ratings

Catalog Number	Nominal Power (1)		Power Part Supply				Drive (output)	
			Max. Input Current		Apparent Power	Max. Inrush Current (2)	Nominal Current (1)	Max. Transient current (1) (3)
	At 200 Vac	At 240 Vac	A	A				
	kW	HP	A	A	kVA	A	A	A
ATH230U04M3	0.37	0.5	3.6	3.0	1.2	9.6	3.3	3.6
ATH230U06M3	0.55	0.75	4.9	4.2	1.7	9.6	3.7	4.1
ATH230U07M3	0.75	1.0	6.3	5.3	2.2	9.6	4.8	5.3
ATH230U11M3	1.1	1.5	8.6	7.2	3.0	9.6	6.9	7.6
ATH230U15M3	1.5	2.0	11.1	9.3	3.9	9.6	8.0	8.8
ATH230U22M3	2.2	3.0	14.9	12.5	5.2	9.6	11.0	12.1
ATH230U30M3	3.0	3.0	18.7	15.7	6.5	28.7	13.7	15.1
ATH230U40M3	4.0	5.0	23.8	19.9	8.3	28.7	17.5	19.3
ATH230U55M3	5.5	7.5	35.4	29.8	12.4	35.2	27.5	30.3
ATH230U75M3	7.5	10.0	45.3	38.2	15.9	35.2	33.0	36.3
ATH230D11M3	11.0	15.0	60.9	51.4	21.4	66.7	54.0	59.4
ATH230D15M3	15.0	20.0	79.7	67.1	27.9	66.7	66.0	72.6

- (1) The switching frequency is adjustable from 2...16 kHz, rated value: 4 kHz.
For operation at switching frequencies higher than the rated value. Derating must be applied to the drive (output) current, page 70. In this case, switching frequency can be reduced if an excessive temperature rise occurs.
- (2) Peak current when power is switched On, for the maximum supply mains voltage.
- (3) The drive is designed to run up to 60 s at 110% of nominal current.

3-phase supply voltage: 380 (-15%)...500 (+10%) Vac 50/60 Hz

Power and Current Ratings

Catalog Number	Nominal Power (1)		Power Part Supply				Drive (output)	
			Max. Input Current		Apparent Power	Max. Inrush Current (2)	Nominal Current (1)	Max. Transient current (1) (3)
	At 380 Vac	At 500 Vac	A	A				
	kW	HP	A	A	kVA	A	A	A
ATH230U06N4	0.55	0.75	2.8	2.2	1.9	10.0	1.9	2.1
ATH230U07N4	0.75	1.0	3.6	2.7	2.3	10.0	2.3	2.5
ATH230U11N4	1.1	1.5	5.0	3.8	3.3	10.0	3.0	3.3
ATH230U15N4	1.5	2.0	6.5	4.9	4.2	10.0	4.1	4.5
ATH230U22N4	2.2	3.0	8.7	6.6	5.7	10.0	5.5	6.1
ATH230U30N4	3.0	3.0	11.1	8.4	7.3	10.0	7.1	7.8
ATH230U40N4	4.0	5.0	13.7	10.5	9.1	10.0	9.5	10.5
ATH230U55N4	5.5	7.5	20.7	14.5	12.6	27.6	14.3	15.7
ATH230U75N4	7.5	10.0	26.5	18.7	16.2	27.6	17.0	18.7
ATH230D11N4	11.0	15.0	36.6	25.6	22.2	36.7	27.7	30.5
ATH230D15N4	15.0	20.0	47.3	33.3	28.8	36.7	33.0	36.3
ATH230D18N4	18.5	24.8	55.3	42.4	36.7	36.7	40	44.0
ATH230D22N4	22	29.5	64.6	49.4	42.8	36.7	46	50.6

- (1) The switching frequency is adjustable from 2...16 kHz, rated value: 4 kHz:
For operation at switching frequencies higher than the rated value. Derating must be applied to the drive (output) current, page 70. In this case, switching frequency can be reduced if an excessive temperature rise occurs.
- (2) Peak current when power is switched On, for the maximum supply mains voltage.
- (3) The drive is designed to run up to 60 s at 110% of nominal current.

3-phase supply voltage: 525 (-15%) ...600 (+10%) Vac 50/60 Hz

Power and Current Ratings

Catalog Number	Nominal Power (1)		Power Part Supply				Drive (output)	
			Max. Input Current		Apparent Power	Max. Inrush Current (2)	Nominal Current (1)	Max. Transient current (1) (3)
	At 525 Vac	At 600 Vac	A	A				
ATH230U15S6	1.5	2.0	2.6	2.4	2.5	12.0	2.7	3.0
ATH230U22S6	2.2	3.0	3.7	3.2	3.4	12.0	3.9	4.3
ATH230U40S6	4.0	5.0	6.5	5.8	6.0	12.0	6.1	6.7
ATH230U55S6	5.5	7.5	8.4	7.5	7.8	33.1	9.0	9.9
ATH230U75S6	7.5	10.0	11.6	10.5	10.9	33.1	11.0	12.1
ATH230D11S6	11.0	15.0	15.8	14.1	14.7	44.0	17.0	18.7
ATH230D15S6	15.0	20.0	22.1	20.1	20.9	44.0	22.0	24.2

- (1) The switching frequency is adjustable from 2...16 kHz, rated value: 4 kHz:
For operation at switching frequencies higher than the rated value. Derating must be applied to the drive (output) current, page 70. In this case, switching frequency can be reduced if an excessive temperature rise occurs.
- (2) Peak current when power is switched On, for the maximum supply mains voltage.
- (3) The drive is designed to run up to 60 s at 110% of nominal current.

Electrical Data - Upstream Protective Device

What's in This Chapter

Upstream Protective Device – Introduction	43
Prospective Short-Circuit Current	45
IEC Type Circuit-Breaker — with enclosure	47
IEC Type Circuit-Breaker — wall mounted	50
IEC Fuses — with enclosure	52
IEC Fuses — wall mounted	54
UL Circuit-Breakers and Fuses	58

Upstream Protective Device – Introduction

Overview

⚠️⚠️ DANGER

INSUFFICIENT PROTECTION AGAINST OVERCURRENTS CAN CAUSE FIRE OR EXPLOSION

- Use properly rated overcurrent protection devices.
- Use the fuses/circuit breakers specified.
- Do not connect the product to a supply mains whose prospective short circuit current rating (current that flows during a short circuit) exceeds the specified maximum permissible value.
- When rating the upstream mains fuses and the cross sections as well as the lengths of the mains cables, take into account the minimum required prospective short-circuit current (Isc). Refer to the Upstream Protection Device section.
- If the minimum required prospective short-circuit current (Isc) is not available, increase the power of the transformer or decrease the length of the cables.

Failure to follow these instructions will result in death or serious injury.

The values and products for IEC compliance are specified in the present manual.

The values and products for UL/CSA compliance are specified in the ATH200 Getting Started Annex, page 13 provided with the product.

General

- The Short Circuit Protective Device (SCPD) rated to the drive will help protect the upstream installation in case of a short-circuit internal to the drive and mitigate the damage to the drive and its surrounding area.
- The SCPD rated to the drive is mandatory to help ensuring the safety of the Power Drive System.
It comes in addition to the upstream branch circuit protection which is in compliance with the local regulation for electrical installation.
- The SCPD shall mitigate the damage in case of detected error condition such as an internal short-circuit of the drive.
- The SCPD must take into account both following characteristics...
 - a maximum prospective short-circuit current
 - a minimum required prospective short-circuit current (Isc).

If the minimum required prospective short-circuit current (Isc) is not available, increase the power of the transformer or decrease the length of the cables

In other cases, contact your Schneider Electric Customer Care Center (CCC) www.se.com/CCC for specific selection of Short Circuit Protective Device (SCPD).

Note: The electronic power output short-circuit protection circuitry meets the requirements of IEC 60364-4-41:2005/AMD1 — Clause 411.

Wiring Diagram

This diagram shows an example of installation with both SCPD types, Circuit-breaker and Fuse link rated to the drive.

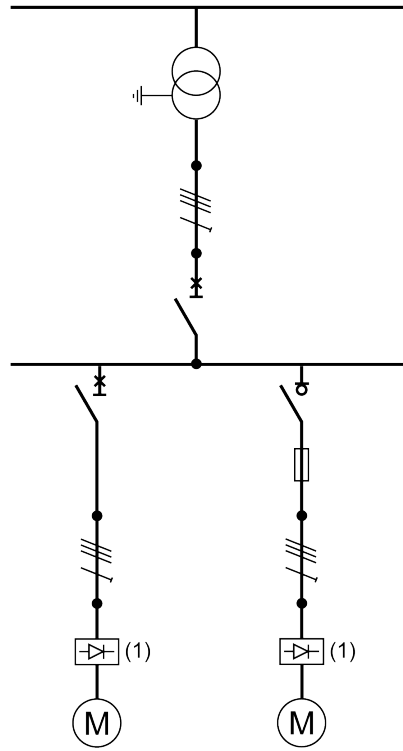

(1) Drive

Prospective Short-Circuit Current

Calculation

The prospective short-circuit current shall be computed at the drive connection points.

We recommend using the Schneider Electric tool Ecodial Advance Calculation



available on www.se.com/en/product-range-presentation/61013-ecodial-advance-calculation/

The following equations allow to estimate the value of the symmetrical three-phase prospective short-circuit current (I_{sc}) at the drive connection points.

$$X_t = \frac{U^2}{S_n} \cdot usc$$

$$Z_{cc} = \sqrt{\left(\rho \cdot \frac{l}{S} + R_f\right)^2 + (X_t + X_c \cdot l + X_f)^2}$$

$$I_{sc} = \frac{U}{\sqrt{3}} \cdot \frac{1}{Z_{cc}}$$

I_{sc}	Symmetrical three-phase prospective short-circuit current (kA)
X_t	Transformer reactance
U	No-load phase to phase voltage of the transformer (V)
S_n	Apparent transformer power (kVA)
usc	Short-circuit voltage, according to the transformer data sheet (%)
Z_{cc}	Total short-circuit impedance (m Ω)
ρ	Conductor resistivity e.g. Cu: 0.01851 m Ω .mm
l	Conductor length (mm)
S	Conductor cross section (mm ²)
X_c	Conductor lineic reactance (0.0001 m Ω /mm)
R_f, X_f	Resistance and reactance of the line filter (m Ω) , page 47

Example of Calculation with Copper Cable (without line filter)

Transformer 50 Hz	U 400 Vac Usc	Cable Cross Section	Isc depending on cable length in m(ft)							
			10 (33)	20 (66)	40 (131)	80 (262)	100 (328)	160 (525)	200 (656)	320 (1,050)
kVA	%	mm ² (AWG)	kA	kA	kA	kA	kA	kA	kA	kA
100	4	2.5 (14)	2.3	1.4	0.8	0.4	0.3	0.2	0.2	0.1
		4 (12)	2.9	2.0	1.2	0.6	0.5	0.3	0.2	0.2
		6 (10)	3.2	2.6	1.6	0.9	0.7	0.5	0.4	0.2
		10 (8)	3.4	3.1	2.3	1.4	1.2	0.8	0.6	0.4
		25 (4)	3.5	3.4	3.1	2.5	2.2	1.6	1.4	0.9
		50 (0)	3.5	3.5	3.3	3.0	2.8	2.3	2.1	1.5
		70 (00)	3.5	3.5	3.4	3.1	2.9	2.6	2.3	1.8
		120 (250 MCM)	3.6	3.5	3.4	3.2	3.1	2.8	2.6	2.1
250	4	6 (10)	5.7	3.4	1.8	0.9	0.7	0.5	0.4	0.2
		10 (8)	7.1	5.0	2.9	1.5	1.2	0.8	0.6	0.4
		25 (4)	8.4	7.4	5.5	3.4	2.8	1.8	1.5	0.9
		50 (0)	8.6	8.1	7.0	5.2	4.5	3.2	2.7	1.8
		70 (00)	8.6	8.2	7.3	5.8	5.2	3.9	3.3	2.3
		120 (250 MCM)	8.7	8.3	7.6	6.5	6.0	4.8	4.2	3.0
400	4	6 (10)	6.6	3.6	1.8	0.9	0.7	0.5	0.4	0.2
		10 (8)	9.2	5.6	3.0	1.5	1.2	0.8	0.6	0.4
		25 (4)	12	9.9	6.5	3.6	2.9	1.9	1.5	1.0
		50 (0)	13	12	9.3	6.1	5.1	3.4	2.8	1.8
		70 (00)	13	12	10	7.2	6.2	4.4	3.6	2.4
		120 (250 MCM)	13	13	11	8.6	7.6	5.7	4.9	3.4
800	6	6 (10)	6.9	3.7	1.9	0.9	0.7	0.5	0.4	0.2
		10 (8)	10	5.8	3.0	1.5	1.2	0.8	0.6	0.4
		25 (4)	15	11	6.9	3.7	3.0	1.9	1.5	1.0
		50 (0)	17	15	11	6.5	5.4	3.5	2.9	1.8
		70 (00)	17	15	12	7.9	6.7	4.6	3.7	2.4
		120 (250 MCM)	17	16	13	9.8	8.6	6.2	5.2	3.5
1,000	6	6 (10)	7.1	3.7	1.9	0.9	0.7	0.5	0.4	0.2
		10 (8)	11	6.0	3.1	1.5	1.2	0.8	0.6	0.4
		25 (4)	18	12	7.1	3.7	3.0	1.9	1.5	1.0
		50 (0)	21	17	12	6.7	5.5	3.6	2.9	1.8
		70 (00)	21	18	13	8.4	7.0	4.7	3.8	2.4
		120 (250 MCM)	22	19	16	11	9.3	6.5	5.4	3.6

Additional Line Filter Option

If a line input filter option is required for the installation such as a line reactor or a passive harmonic filter, the minimum prospective short-circuit current capability of the source is reduced at the drive connection point and shall be estimated (see Calculation, page 45) with the impedance values given in the table below.

Then, the SCPD type shall be selected according to the drive. If no selection is available, Schneider Electric Customer Care Center (CCC) www.se.com/CCC should be contacted.

EMC filter series have no significant effect on the minimum prospective short-circuit current capability of the main source.

Through the line option, the I_{sc} will be limited to a maximum value independent of the transformer and cable. **Therefore the below equations can be used to estimate the minimum prospective short-circuit current capability.**

$$10 \text{ m}\Omega \leq Xf \leq 400 \text{ m}\Omega \Rightarrow I_{sc_{\max i}} (\text{kA}) = 4.7 - 0.7 \cdot \text{Log}(Xf)$$

$$400 \text{ m}\Omega \leq Xf \leq 2000 \text{ m}\Omega \Rightarrow I_{sc_{\max i}} (\text{kA}) = 2.05 - 0.26 \cdot \text{Log}(Xf)$$

Log: Natural logarithm

Line Choke Filters Impedance Values

Line Choke Filter	Xf in mΩ
VW3A4551	700
VZ1L007UM50, VW3A4552	300
VZ1L018UM20, VW3A4553	100
VW3A4554	70
VW3A4555	30
VW3A4556	20

IEC Type Circuit-Breaker — with enclosure

⚠️⚠️ DANGER

HAZARD OF ELECTRIC SHOCK, EXPLOSION, OR FIRE

The opening of the branch-circuit protective device is able to be an indication that a fault current has been interrupted.

- Current-carrying parts and other components of the controller should be examined and replaced if damaged.
- If burnout of the current element of an overload relay occurs, the complete overload relay must be replaced.

Failure to follow these instructions will result in death or serious injury.

Function

The circuit-breaker offers enhanced features versus fuse-link since it cumulates 3 functionalities:

- insulation with lock,
- switch (full load interruption),
- downstream short-circuit protection without replacement.

Short Circuit Current Ratings: Selection Table

Note:

- Integral solid state short circuit protection in the drive does not provide branch circuit protection. Branch circuit protection must be provided in accordance with any local codes.
- The drive has a 100 kA interrupt rating on the output of the drive. In addition to providing a rating based on shorting the output of the drive, these short circuit current ratings have been obtained by shorting components internal to the drive. These ratings allow proper coordination of short circuit protection.

Note: Verify that the minimum required prospective short-circuit current (Isc) value from the table above is lower than the value estimated in the Calculation section, page 45.

240 Vac single-phase (50/60 Hz)

Note: Suitable for use on a circuit capable of delivering not more than X rms symmetrical kiloAmperes, **240 Vac** Volts maximum, when protected by Z1 with a maximum rating of Z2 .

Circuit breakers can be chosen as SCPD according to the following table:

Drive Catalog Number	PowerPacT Catalog Number (a) (Z1, Z2)	SCCR (X)		Tesys GV / ComPact Catalog number (Z1, Z2)	Irm (A)	SCCR (X)		Minimum Enclosure Volume	
		Min (A)	Max (kA)			Min (A)	Max (kA)	(L)	(in ³)
ATH230U04M2	B•L36015	1500	5	GV2L10	78	200	5	53	3223
ATH230U06M2	B•L36015	1500	5	GV2L14	138	300	5	53	3223
ATH230U07M2	B•L36020	1500	5	GV2L16	170	300	5	53	3223
ATH230U11M2	B•L36020	1500	5	GV2L16	170	300	5	53	3223
ATH230U15M2	B•L36030	1500	5	GV2L20	223	400	5	53	3223
ATH230U22M2	B•L36035	1700	5	GV2L22	327	600	5	53	3223

NOTE: (a): about PowerPacT Catalog Number: for references to be completed, replace • with the letter corresponding to the breaking performance of the circuit breaker:
D for 25 kA, **G** for 65 kA, **J** for 100 kA, **L** for 100 kA, **R** for 100 kA.

240 Vac three-phase (50/60 Hz)

Note: Suitable for use on a circuit capable of delivering not more than X rms symmetrical kiloAmperes, **240 Vac** Volts maximum, when protected by Z1 with a maximum rating of Z2 .

Circuit breakers can be chosen as SCPD according to the following table:

Drive Catalog Number	PowerPacT Catalog Number (a) (Z1, Z2)	SCCR (X)		TesyS GV / ComPact Catalog number (Z1, Z2)	I _{rm} (A)	SCCR (X)		Minimum Enclosure Volume	
		Min (A)	Max (kA)			Min (A)	Max (kA)	(L)	(in ³)
ATH230U04M3	B●L36015	1500	5	GV2L08	51	100	5	53	3223
ATH230U06M3	B●L36015	1500	5	GV2L10	78	200	5	53	3223
ATH230U07M3	B●L36015	1500	5	GV2L14	138	300	5	53	3223
ATH230U11M3	B●L36015	1500	5	GV2L14	138	300	5	53	3223
ATH230U15M3	B●L36015	1500	5	GV2L16	170	300	5	53	3223
ATH230U22M3	B●L36020	1500	5	GV2L20	223	400	5	53	3223
ATH230U30M3	B●L36020	1500	5	GV2L22	327	600	5	53	3223
ATH230U40M3	B●L36030	1500	5	GV2L22	327	600	5	53	3223
ATH230U55M3	B●L36040	1700	22	GV3L40	560	900	22	53	3223
ATH230U75M3	B●L36050	1700	22	GV3L50	700	1100	22	53	3223
ATH230D11M3	B●L36070	3000	22	GV3L65	910	1800	22	53	3223
ATH230D15M3	B●L36090	3000	22	GV3L80	1100	2300	22	53	3223

NOTE: (a): about PowerPacT Catalog Number: for references to be completed, replace ● with the letter corresponding to the breaking performance of the circuit breaker:
D for 25 kA, **G** for 65 kA, **J** for 100 kA, **L** for 100 kA, **R** for 100 kA.

480 Vac three-phase (50/60 Hz)

Note: Suitable for use on a circuit capable of delivering not more than X rms symmetrical kiloAmperes, **480 Vac** Volts maximum, when protected by Z1 with a maximum rating of Z2 .

Circuit breakers can be chosen as SCPD according to the following table:

Drive Catalog Number	PowerPacT Catalog Number (a) (Z1, Z2)	SCCR (X)		Tesys GV / ComPact Catalog number (Z1, Z2)	I _{rm} (A)	SCCR (X)		Minimum Enclosure Volume	
		Min (A)	Max (kA)			Min (A)	Max (kA)	(L)	(in ³)
ATH230U06N4	B•L36015	1500	5	GV2L08	51	100	5	53	3223
ATH230U07N4	B•L36015	1500	5	GV2L08	51	100	5	53	3223
ATH230U11N4	B•L36015	1500	5	GV2L10	78	200	5	53	3223
ATH230U15N4	B•L36015	1500	5	GV2L14	138	300	5	53	3223
ATH230U22N4	B•L36015	1500	5	GV2L14	138	300	5	53	3223
ATH230U30N4	B•L36015	1500	5	GV2L16	170	300	5	53	3223
ATH230U40N4	B•L36015	1500	5	GV2L16	170	300	5	53	3223
ATH230U55N4	B•L36020	1500	22	GV2L22	327	600	22	53	3223
ATH230U75N4	B•L36030	1500	22	GV2L32	416	700	22	53	3223
ATH230D11N4	B•L36040	1700	22	GV3L40	560	900	22	53	3223
ATH230D15N4	B•L36050	1700	22	GV3L50	700	1100	22	53	3223
ATH230D18N4	B•L36060	3000	22	GV3L65	910	1800	22	63	3840
ATH230D22N4	B•L36070	3000	22	GV3L65	910	1800	22	63	3840

NOTE: (a): about PowerPacT Catalog Number: for references to be completed, replace • with the letter corresponding to the breaking performance of the circuit breaker:

D for 18 kA, **G** for 35 kA, **J** for 65 kA, **L** for 100 kA, **R** for 100 kA.

IEC Type Circuit-Breaker — wall mounted

⚡ ⚠ DANGER

HAZARD OF ELECTRIC SHOCK, EXPLOSION, OR FIRE

The opening of the branch-circuit protective device is able to be an indication that a fault current has been interrupted.

- Current-carrying parts and other components of the controller should be examined and replaced if damaged.
- If burnout of the current element of an overload relay occurs, the complete overload relay must be replaced.

Failure to follow these instructions will result in death or serious injury.

Function

The circuit-breaker offers enhanced features versus fuse-link since it cumulates 3 functionalities:

- insulation with lock,
- switch (full load interruption),

- downstream short-circuit protection without replacement.

Short Circuit Current Ratings: Selection Table

Note:

- Integral solid state short circuit protection in the drive does not provide branch circuit protection. Branch circuit protection must be provided in accordance with any local codes.
- The drive has a 100 kA interrupt rating on the output of the drive. In addition to providing a rating based on shorting the output of the drive, these short circuit current ratings have been obtained by shorting components internal to the drive. These ratings allow proper coordination of short circuit protection.

Note: Verify that the minimum required prospective short-circuit current (Isc) value from the table above is lower than the value estimated in the Calculation section, page 45.

480 Vac three-phase (50/60 Hz) with wall mounting fixing kit

Note: Suitable for use on a circuit capable of delivering not more than X rms symmetrical kiloAmperes, **480 Vac** Volts maximum, when protected by Z1 with a maximum rating of Z2 .

Circuit breakers can be chosen as SCPD according to the following table:

Drive Catalog Number	Wall mounting fixing kit	PowerPacT Catalog Number (a) (Z1, Z2)	SCCR (X)		Tesys GV / ComPact Catalog number (Z1, Z2)	Irm (A)	SCCR (X)	
			Min (A)	Max (kA)			Min (A)	Max (kA)
ATH230U06N4	VW3A95812	B●L36015	1500	5	GV2L08	51	100	5
ATH230U07N4	VW3A95812	B●L36015	1500	5	GV2L08	51	100	5
ATH230U11N4	VW3A95812	B●L36015	1500	5	GV2L10	78	200	5
ATH230U15N4	VW3A95812	B●L36015	1500	5	GV2L14	138	300	5
ATH230U22N4	VW3A95814	B●L36015	1500	5	GV2L14	138	300	5
ATH230U30N4	VW3A95814	B●L36015	1500	5	GV2L16	170	300	5
ATH230U40N4	VW3A95814	B●L36015	1500	5	GV2L16	170	300	5
ATH230U55N4	VW3A95816	B●L36020	1500	22	GV2L22	327	600	22
ATH230U75N4	VW3A95816	B●L36030	1500	22	GV2L32	416	700	22
ATH230D11N4	VW3A95818	B●L36040	1700	22	GV3L40	560	900	22
ATH230D15N4	VW3A95818	B●L36050	1700	22	GV3L50	700	1100	22
ATH230D18N4	VW3A9925	B●L36060	3000	22	GV3L65	910	1800	22
ATH230D22N4	VW3A9925	B●L36070	3000	22	GV3L65	910	1800	22

NOTE: (a): about PowerPacT Catalog Number: for references to be completed, replace ● with the letter corresponding to the breaking performance of the circuit breaker:

D for 18 kA, **G** for 35 kA, **J** for 65 kA, **L** for 100 kA, **R** for 100 kA.

IEC Fuses — with enclosure

Introduction

⚡⚠ DANGER

HAZARD OF ELECTRIC SHOCK, EXPLOSION, OR FIRE

The opening of the branch-circuit protective device is able to be an indication that a fault current has been interrupted.

- Current-carrying parts and other components of the controller should be examined and replaced if damaged.
- If burnout of the current element of an overload relay occurs, the complete overload relay must be replaced.

Failure to follow these instructions will result in death or serious injury.

Short Circuit Current Ratings: Selection Table

Note:

- Integral solid state short circuit protection in the drive does not provide branch circuit protection. Branch circuit protection must be provided in accordance with any local codes.
- The drive has a 100 kA interrupt rating on the output of the drive. In addition to providing a rating based on shorting the output of the drive, these short circuit current ratings have been obtained by shorting components internal to the drive. These ratings allow proper coordination of short circuit protection.

Note: Verify that the minimum required prospective short-circuit current (Isc) value from the table above is lower than the value estimated in the Calculation section, page 45.

240 Vac Single-phase (50/60 Hz)

Note: Suitable for use on a circuit capable of delivering not more than X rms symmetrical kiloAmperes, **240 Vac** Volts maximum, when protected by Z1 with a maximum rating of Z2 .

Current limiting fuses can be chosen as SCPD according to the following table:

Drive Catalog Number	gG (Z1, Z2)			gR-gS-aR (Z1, Z2)			Minimum size	Minimum Enclosure Volume	
	(A)	SCCR (X)		(A)	SCCR (X)				
		Min (A)	Max (kA)		Min (A)	Max (kA)		(L)	(in ³)
ATH230U04M2	12	300	5	12,5	200	5	10x38	53	3223
ATH230U06M2	16	400	5	16	200	5	10x38	53	3223
ATH230U07M2	20	1000	5	25	200	5	10x38	53	3223
ATH230U11M2	25	1000	5	32	300	5	10x38	53	3223
ATH230U15M2	32	2000	5	40	500	5	000	53	3223
ATH230U22M2	40	2000	5	50	500	5	000	53	3223

240 Vac Three-phase (50/60 Hz)

Note: Suitable for use on a circuit capable of delivering not more than X rms symmetrical kiloAmperes, **240 Vac** Volts maximum, when protected by Z1 with a maximum rating of Z2 .

Current limiting fuses can be chosen as SCPD according to the following table:

Drive Catalog Number	gG (Z1, Z2)			gR-gS-aR (Z1, Z2)			Minimum size	Minimum Enclosure Volume	
	(A)	SCCR (X)		(A)	SCCR (X)			(L)	(in ³)
		Min (A)	Max (kA)		Min (A)	Max (kA)			
ATH230U04M3	8	200	5	8	100	5	10x38	53	3223
ATH230U06M3	10	300	5	10	100	5	10x38	53	3223
ATH230U07M3	12	300	5	12,5	200	5	10x38	53	3223
ATH230U11M3	16	400	5	20	200	5	10x38	53	3223
ATH230U15M3	20	1000	5	25	300	5	10x38	53	3223
ATH230U22M3	25	1000	5	32	500	5	10x38	53	3223
ATH230U30M3	40	2000	5	50	800	5	14x51	53	3223
ATH230U40M3	40	2000	5	50	800	5	14x51	53	3223
ATH230U55M3	63	3000	22	80	1500	22	22x58	53	3223
ATH230U75M3	80	4000	22	80	1500	22	000	53	3223
ATH230D11M3	100	5500	22	125	2000	22	000	53	3223
ATH230D15M3	125	6500	22	160	2500	22	00	53	3223

480 Vac Three-phase (50/60 Hz)

Note: Suitable for use on a circuit capable of delivering not more than X rms symmetrical kiloAmperes, **480 Vac** Volts maximum, when protected by Z1 with a maximum rating of Z2 .

Current limiting fuses can be chosen as SCPD according to the following table:

Drive Catalog Number	gG (Z1, Z2)			gR-gS-aR (Z1, Z2)			Minimum size	Minimum Enclosure Volume	
	(A)	SCCR (X)		(A)	SCCR (X)				
		Min (A)	Max (kA)		Min (A)	Max (kA)		(L)	(in ³)
ATH230U06N4	6	200	5	8	100	5	10x38	53	3223
ATH230U07N4	8	200	5	8	100	5	10x38	53	3223
ATH230U11N4	10	300	5	10	100	5	10x38	53	3223
ATH230U15N4	12	300	5	12,5	200	5	10x38	53	3223
ATH230U22N4	16	400	5	20	200	5	10x38	53	3223
ATH230U30N4	20	1000	5	25	300	5	10x38	53	3223
ATH230U40N4	25	1000	5	32	500	5	10x38	53	3223
ATH230U55N4	40	2000	22	50	800	22	14x51	53	3223
ATH230U75N4	50	2000	22	63	1000	22	14x51	53	3223
ATH230D11N4	63	3000	22	80	1500	22	000	53	3223
ATH230D15N4	80	4000	22	80	1500	22	000	53	3223
ATH230D18N4	100	5500	22	100	1500	22	–	63	3840
ATH230D22N4	125	6500	22	125	2000	22	–	63	3840

IEC Fuses — wall mounted

Introduction

DANGER

HAZARD OF ELECTRIC SHOCK, EXPLOSION, OR FIRE

The opening of the branch-circuit protective device is able to be an indication that a fault current has been interrupted.

- Current-carrying parts and other components of the controller should be examined and replaced if damaged.
- If burnout of the current element of an overload relay occurs, the complete overload relay must be replaced.

Failure to follow these instructions will result in death or serious injury.

Short Circuit Current Ratings: Selection Table

Note:

- Integral solid state short circuit protection in the drive does not provide branch circuit protection. Branch circuit protection must be provided in accordance with any local codes.
- The drive has a 100 kA interrupt rating on the output of the drive. In addition to providing a rating based on shorting the output of the drive, these short circuit current ratings have been obtained by shorting components internal to the drive. These ratings allow proper coordination of short circuit protection.

Note: Verify that the minimum required prospective short-circuit current (Isc) value from the table above is lower than the value estimated in the Calculation section, page 45.

240 Vac Single-phase (50/60 Hz)

Note: Suitable for use on a circuit capable of delivering not more than X rms symmetrical kiloAmperes, **240 Vac** Volts maximum, when protected by Z1 with a maximum rating of Z2 .

Current limiting fuses can be chosen as SCPD according to the following table:

Drive Catalog Number	Wall mounting kit	gG (Z1, Z2)			gR-gS-aR (Z1, Z2)			Minimum size
			SCCR (X)			SCCR (X)		
			Min (A)	Max (kA)		Min (A)	Max (kA)	
ATH230U04M2	VW3A95811 —	12	300	5	12,5	200	5	10x38
ATH230U06M2	VW3A95811 —	16	400	5	16	200	5	10x38
ATH230U07M2	VW3A95811 —	20	1000	5	25	300	5	10x38
ATH230U11M2	VW3A95812 —	25	1000	5	32	500	5	10x38
ATH230U15M2	VW3A95812 —	32	2000	5	40	500	5	000
ATH230U22M2	VW3A95812 —	40	2000	5	50	800	5	000

240 Vac Three-phase (50/60 Hz)

Note: Suitable for use on a circuit capable of delivering not more than X rms symmetrical kiloAmperes, **240 Vac** Volts maximum, when protected by Z1 with a maximum rating of Z2 .

Current limiting fuses can be chosen as SCPD according to the following table:

Drive Catalog Number	Wall mounting kit	gG (Z1, Z2)			gR-gS-aR (Z1, Z2)			Minimum size
		(A)	SCCR (X)		(A)	SCCR (X)		
			Min (A)	Max (kA)		Min (A)	Max (kA)	
ATH230U04M3	VW3A95811	8	200	5	8	100	5	10x38
ATH230U06M3	VW3A95811	10	300	5	10	100	5	10x38
ATH230U07M3	VW3A95811	12	300	5	12,5	200	5	10x38
ATH230U11M3	VW3A95813	16	400	5	20	200	5	10x38
ATH230U15M3	VW3A95813	20	1000	5	25	300	5	10x38
ATH230U22M3	VW3A95813	25	1000	5	32	500	5	10x38
ATH230U30M3	VW3A95815	30	2000	5	50	800	5	14x51
ATH230U40M3	VW3A95815	40	2000	5	50	800	5	14x51
ATH230U55M3	VW3A95816	63	3000	22	80	1500	22	22x58
ATH230U75M3	VW3A95816	80	4000	22	80	1500	22	000
ATH230D11M3	VW3A95818	100	5500	22	125	2000	22	000
ATH230D15M3	VW3A95818	125	6500	22	160	2500	22	00

480 Vac Three-phase (50/60 Hz)

Note: Suitable for use on a circuit capable of delivering not more than X rms symmetrical kiloAmperes, **480 Vac** Volts maximum, when protected by Z1 with a maximum rating of Z2 .

Current limiting fuses can be chosen as SCPD according to the following table:

Drive Catalog Number	Wall mounting kit	gG (Z1, Z2)			gR-gS-aR (Z1, Z2)			Minimum size
		(A)	SCCR (X)		(A)	SCCR (X)		
			Min (A)	Max (kA)		Min (A)	Max (kA)	
ATH230U06N4	VW3A95812 —	6	200	5	8	100	5	10x38
ATH230U07N4	VW3A95812 —	8	200	5	8	100	5	10x38
ATH230U11N4	VW3A95812 —	10	300	5	10	100	5	10x38
ATH230U15N4	VW3A95812 —	12	300	5	12,5	200	5	10x38
ATH230U22N4	VW3A95814 —	16	400	5	20	200	5	10x38
ATH230U30N4	VW3A95814 —	20	1000	5	25	300	5	10x38
ATH230U40N4	VW3A95814 —	25	1000	5	32	500	5	10x38
ATH230U55N4	VW3A95816 —	40	2000	22	50	800	22	14x51
ATH230U75N4	VW3A95816 —	50	2000	22	63	1000	22	14x51
ATH230D11N4	VW3A95818 —	63	3000	22	80	1500	22	000
ATH230D15N4	VW3A95818	80	4000	22	80	1500	22	000
ATH230D18N4	VW3A9925	100	5500	22	100	1500	22	—
ATH230D22N4	VW3A9925	125	6500	22	125	2000	22	—

UL Circuit-Breakers and Fuses

Reference Document

UL Fuse and circuit-breaker information is provided in the ATH200 Getting Started Annex, page 13.

Circuit breakers

The following table shows the minimum required prospective short-circuit current (Isc) depending on the drive and **associated circuit-breaker**.

200...240 Vac

ATH230 Drives Catalog Number	Circuit Breakers			
	PowerPact	Min. Isc	GV•P	Min. Isc
		(A)		(A)
ATH230U04M3	H•L36015	1,500	GV2P08	100
ATH230U04M2 ATH230U06M3 ATH230U07M3	H•L36015	1,500	GV2P10	200
ATH230U06M2 ATH230U11M3 ATH230U15M3	H•L36015	1,500	GV2P14	300
ATH230U07M2	H•L36015	1,500	GV2P16	300
ATH230U11M2 ATH230U22M3	H•L36020	1,500	GV2P16	300
ATH230U15M2	H•L36030	1,500	GV2P20	400
ATH230U30M3	H•L36020	1,500	GV2P20	400
ATH230U40M3	H•L36030	1,500	GV2P21	600
ATH2•0U22M2	H•L36035	1,700	GV3P32	700
ATH230U55M3	H•L36040	1,700	GV3P40	900
ATH230U75M3	H•L36050	1,700	GV3P50	1,100
ATH230D11M3	H•L36070	3,000	GV3P65	1,800
ATH230D15M3	H•L36090	3,000	GV4PB80S	6,000

380...500 Vac

ATH230 Drives Catalog Number	Circuit Breakers			
	PowerPact	Min. Isc	GV•P	Min. Isc
		(A)		(A)
ATH230U06N4, ATH230U07N4 ATH230U11N4	H•L36015	1,500	GV2P08	100
ATH230U15N4	H•L36015	1,500	GV2P10	200
ATH230U04N4 ATH230U06N4	H•L36015	1,500	GV2P07	100
ATH230U40N4	H•L36015	1,500	GV3P13	300
ATH230U22N4 ATH230U30N4	H•L36015	1,500	GV2P14	300
ATH230U55N4	H•L36020	1,500	GV3P18	400
ATH230U75N4	H•L36030	1,500	GV3P25	700
ATH230D11N4	H•L36040	1,700	GV3P32	700
ATH230D15N4	H•L36050	1,700	GV3P40	900
ATH230D18N4	H•L36060	3000	GV3P50	1100
ATH230D22N4	H•L36070	3000	GV3P50	1100

525...600 Vac — Only with line choke

ATH230 Drives Catalog Number	Circuit Breakers				Line choke	
	PowerPact	Min. Isc	GV•P	Min. Isc	Min. value	
		(A)		(A)	mH	A
ATH230U15S6	H•L36015	1,500	GV3P13	300	9	1.4
ATH230U22S6	H•L36015	1,500	GV3P13	300	5	3.3

525...600 Vac — Only with line choke (Continued)

ATH230 Drives Catalog Number	Circuit Breakers				Line choke	
	PowerPact	Min. Isc	GV•P	Min. Isc	Min. value	
		(A)		(A)	mH	A
ATH230U40S6	H•L36015	1,500	GV3P13	300	5	6
ATH230U55S6	H•L36025	1,500	GV3P13	300	2.5	8
ATH230U75S6	H•L36030	1,500	GV3P13	400	2.5	11
ATH230D11S6	H•L36045	1,700	GV3P18	700	1.2	16
ATH230D15S6	H•L36060	3,000	GV3P25	700	1.2	22

Fuses

The following table shows the minimum required prospective short-circuit current (Isc) depending on the drive and **associated class J fuse**, according to UL248-8.

200...240 Vac

ATH230 Drives Catalog Number	Class J Fuse to UL248-8	Minimum Isc
	(A)	(A)
ATH230U04M3	7	500
ATH230U04M2 ATH230U06M3 ATH230U07M3	15	500
ATH230U06M2 ATH230U07M2 ATH230U11M2 ATH230U11M3 ATH230U15M3 ATH230U22M3	25	1,000
ATH230U15M2	40	1,500
ATH230U22M2 ATH230U30M3 ATH230U40M3	45	2,000
ATH230U55M3	60	2,000
ATH230U75M3	70	2,000
ATH230D11M3 ATH230D15M3	100	2,500

380...500 Vac

ATH230 Drives Catalog Number	Class J Fuse to UL248-8	Minimum Isc
	(A)	(A)
ATH230U06N4 ATH230U07N4	6	300
ATH230U11N4 ATH230U15N4	12	500
ATH230U22N4	15	500
ATH230U30N4	17.5	500
ATH230U40N4	25	1,000
ATH230U55N4 ATH230U75N4	40	1,500
ATH230D11N4 ATH230D15N4	60	2,000
ATH230D18N4	70	2,000
ATH230D22N4	80	2,000

525...600 Vac — Only with line choke

ATH230 Drives Catalog Number	Class J Fuse to UL248-8	Minimum Isc	Line choke	
			Min. value	
	(A)	(A)	mH	A
ATH230U15S6	6	300	9	1.4
ATH230U22S6	10	500	5	3.3
ATH230U40S6	15	500	5	6
ATH230U55S6	20	500	2.5	8
ATH230U75S6	25	1,000	2.5	11
ATH230D11S6	35	1,500	1.2	16
ATH230D15S6	45	2,000	1.2	22

Drive Mounting

What's in This Part

Mounting Conditions.....	63
Power Dissipated For Enclosed Drives and Required Air Flow.....	68
Derating Curves.....	70
Checking mechanical installation before wiring.....	84

Mounting Conditions

Before You Begin

DANGER

HAZARD OF FIRE OR ELECTRIC SHOCK

- The open type product does not provide comprehensive mitigation for fire hazards and protection against direct contact to hazardous live parts.
- Install the product inside a supplementary enclosure which provides appropriate protection against spread of fire and electric shock.

Failure to follow these instructions will result in death or serious injury.

DANGER

RISK OF FIRE

The device is suitable for mounting on concrete or other non-combustible surfaces only.

Failure to follow these instructions will result in death or serious injury.

Conductive foreign objects may cause parasitic voltage.

DANGER

ELECTRIC SHOCK AND/OR UNANTICIPATED EQUIPMENT OPERATION

- Keep foreign objects such as chips, screws or wire clippings from getting into the product.
- Verify correct seat of seals and cable entries in order to avoid deposits and humidity.

Failure to follow these instructions will result in death or serious injury.

The temperature of the products described in this manual may exceed 80 °C (176 °F) during operation.

WARNING

HOT SURFACES

- Ensure that any contact with hot surfaces is avoided.
- Do not allow flammable or heat-sensitive parts in the immediate vicinity of hot surfaces.
- Verify that the product has sufficiently cooled down before handling it.
- Verify that the heat dissipation is sufficient by performing a test run under maximum load conditions.

Failure to follow these instructions can result in death, serious injury, or equipment damage.

Power Drive Systems (PDS) can generate strong local electrical and magnetic fields. This can cause interference in electromagnetically sensitive devices.

⚠ WARNING

ELECTROMAGNETIC FIELDS

- Keep persons with electronic medical implants, such as pacemakers, away from the equipment.
- Do not place electromagnetically sensitive devices in the vicinity of the equipment.

Failure to follow these instructions can result in death, serious injury, or equipment damage.

General Mounting Instructions

- Mount the device in a vertical position at $\pm 10^\circ$. This is required for cooling the device.
- Attach the device to the mounting surface using screws according to the tables shown within the [Mounting Holes and Screws](#), page 65.
- The position and size of the fixing holes are specified in the chapter [Dimensions and Weights](#), page 29.
- The use of washers is required with all mounting screws.
- Tighten the fixation screws according to the torque value shown within the [Mounting Holes and Screws](#), page 65.
- Do not mount the device outdoors.
- Do not mount the device close to heat sources.
- Avoid environmental effects like high temperatures and high humidity as well as dust, dirt and conductive gases.
- Adhere to the minimum installation distances for required cooling.
- Do not mount the device on flammable materials.
- Mount the device on a flat, solid and vibration-free surface.

Mounting Holes and Screws

Using an impact wrench creates excessive mechanical stress on the mounting brackets.

NOTICE
<p>DESTRUCTION OF THE MOUNTING BRACKETS</p> <ul style="list-style-type: none"> • Do not you use an impact wrench. • The use of washers is required with all mounting screws. <p>Failure to follow these instructions can result in equipment damage.</p>

Machine screw on steel plate

Screw size	Tightening torque range
M4	1.1 to 1.7 N.m
M5	2.6 to 3.3 N.m

Self tapping screw on steel plate

Screw size	Tightening torque range
M4	1.8 to 2.2 N.m
M5	2.8 to 3.5 N.m

Fixation by screws is required for all drives ratings:

- Number of holes: Use the 4 mounting holes.
- Use of only 2 holes is possible (left top and right bottom) on frame sizes 1 and 2.

NOTE: Screws are not delivered with the product.

NOTE: For more information about the holes position, refer to Dimensions and Weights, page 29.

Frame Size 1...3

Frame Size	Top Holes mm (in.)	Bottom holes mm (in.)	Recommended Screws European Standard (US standard #)	Flat Washer Outside diameter European Standard [mm] (US standard [#])
1, 2, 3	5 (0.2)	5 (0.2)	M4 (#8)	10 (#8)

Frame Size 4, 5 products

Frame Size	Top Holes		Bottom holes mm (in.)	Recommended Screws European Standard (US standard #)	Flat Washer Outside diameter European Standard [mm] (US standard [#])
	a mm (in.)	b mm (in.)			
4	5 (0.2)	11 (0.43)	5 (0.2)	M4 (#8)	10 (#8)
5	6 (0.24)	14 (0.55)	6 (0.24)	M5 (#10)	10 (#10)

Clearances and Mounting Position

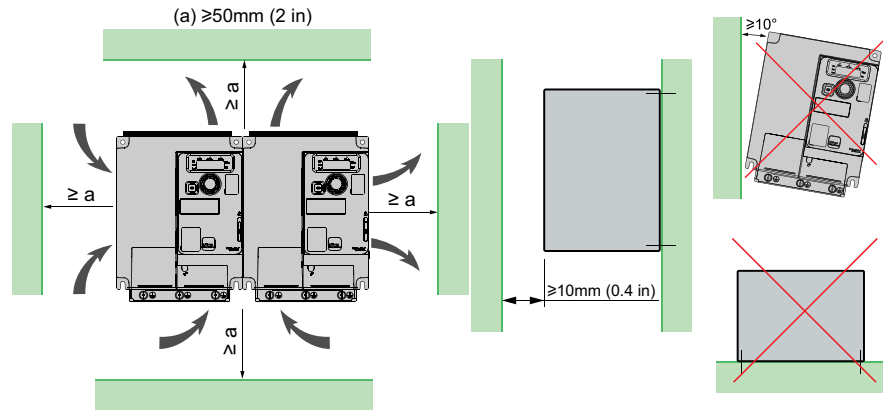

Catalog Number	a (1)
ATH230 drives	50 mm (2 in.)
(1) Minimum value corresponding to thermal constraint.	

Mounting Type A for ATH230 drives

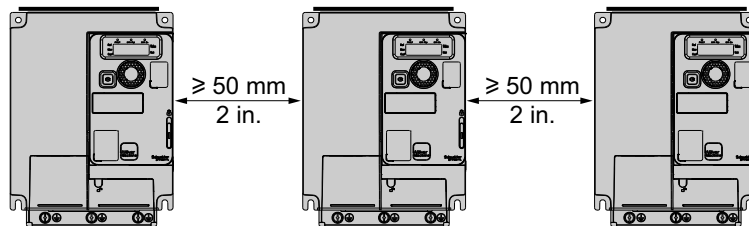

Free space ≥ 50 mm (2 in.) on each side, with vent cover fitted.

Mounting type A is suitable for drive operation at a specific surrounding air temperature. For more information, refer to Derating Curves, page 70.

Mounting Type B for ATH230 drives

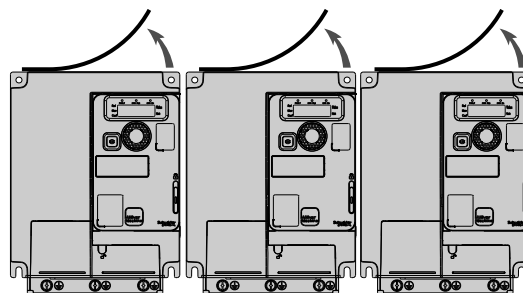

Drives mounted side-by-side, vent cover should be removed. The degree of protection still IP20.

Mounting type B is suitable for drive operation at a specific surrounding air temperature. For more information, refer to Derating Curves, page 70.

NOTE: Use a tool to peel off the top label.

Mounting Type C for ATH230 drives

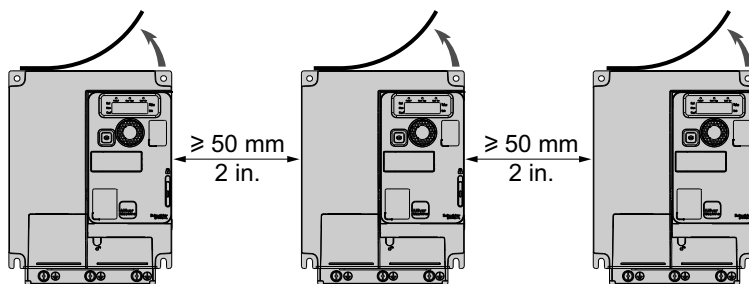

The degree of protection still IP20. Free space ≥ 50 mm (2 in.) on each side. Vent cover should be removed for operation at a specific surrounding air temperature. For more information, refer to *Derating Curves*, page 70.

NOTE: Use a tool to peel off the top label.

Attaching A Label With Safety Instructions

A label kit is provided with the drive.

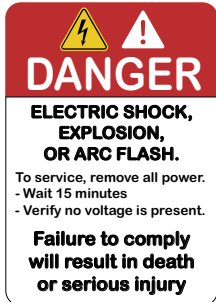
Step	Action
1	Observe the safety regulations in the targeted country
2	Select the label suitable for the targeted country
3	<p>Attach the label to the front of the device so that it is clearly visible. Below is the English version</p>  <p>NOTE: Products used in Canada according to CSA C22.2 no.274 must comply with the requirement defined by the Canadian Advisory council of Electrical Safety (CACES).</p> <p>It defines that dual language (French and English) safety labeling is required on all products for use in Canada</p> <p>To fulfill this requirement, add the French language safety label on the front panel of the product.</p>

Power Dissipated For Enclosed Drives and Required Air Flow

ATH230 drives

M2 references

Catalog Number	Cooling Type	Power Dissipated (1)	Minimum Air Flow Rate Required	
		(W)	(m ³ /h)	(ft ³ /min)
ATH230U04M2	Fanless	30	–	–
ATH230U06M2	Fanless	33	–	–
ATH230U07M2	Fanless	45	–	–
ATH230U11M2	Forced cooling	61	16	9.4
ATH230U15M2	Forced cooling	76	16	9.4
ATH230U22M2	Forced cooling	99	16	9.4

(1) Power dissipated at nominal current

M3 references

Catalog Number	Cooling Type	Power Dissipated (1)	Minimum Air Flow Rate Required	
		(W)	(m ³ /h)	(ft ³ /min)
ATH230U04M3	Fanless	27	–	–
ATH230U06M3	Fanless	31	–	–
ATH230U07M3	Fanless	42	–	–
ATH230U11M3	Forced cooling	58	14.8	8.7
ATH230U15M3	Forced cooling	72	14.8	8.7
ATH230U22M3	Forced cooling	91	14.8	8.7
ATH230U30M3	Forced cooling	105	16.4	9.7
ATH230U40M3	Forced cooling	140	16.4	9.7
ATH230U55M3	Forced cooling	242	60	35.3
ATH230U75M3	Forced cooling	293	60	35.3
ATH230D11M3	Forced cooling	468	156	91.8
ATH230D15M3	Forced cooling	551	156	91.8

(1) Power dissipated at nominal current

N4 references

Catalog Number	Cooling Type	Power Dissipated (1)	Minimum Air Flow Rate Required	
		(W)	(m ³ /h)	(ft ³ /min)
ATH230U06N4	Forced cooling	27	18	10.6
ATH230U07N4	Forced cooling	32	18	10.6
ATH230U11N4	Forced cooling	40	18	10.6
ATH230U15N4	Forced cooling	56	18	10.6
ATH230U22N4	Forced cooling	74	37.7	22.2
ATH230U30N4	Forced cooling	93	37.7	22.2
ATH230U40N4	Forced cooling	111	37.7	22.2
ATH230U55N4	Forced cooling	195	60	35.3
ATH230U75N4	Forced cooling	229	60	35.3
ATH230D11N4	Forced cooling	370	156	91.8
ATH230D15N4	Forced cooling	452	156	91.8
ATH230D18N4	Forced cooling	440	128	75,3
ATH230D22N4	Forced cooling	529	128	75,3

(1) Power dissipated at nominal current

S6 references

Catalog Number	Cooling Type	Power Dissipated (1)	Minimum Air Flow Rate Required	
		(W)	(m ³ /h)	(ft ³ /min)
ATH230U15S6	Forced cooling	54	18	10.6
ATH230U22S6	Forced cooling	77	37.7	22.2
ATH230U40S6	Forced cooling	96	37.7	22.2
ATH230U55S6	Forced cooling	148	60	35.3
ATH230U75S6	Forced cooling	175	60	35.3
ATH230D11S6	Forced cooling	267	156	91.8
ATH230D15S6	Forced cooling	317	156	91.8

(1) Power dissipated at nominal current

Derating Curves

What's in This Chapter

Derating Curves — ATH230●●●M2	71
Derating Curves — ATH230●●●M3	72
Derating Curves — ATH230●●●N4	75
Derating Curves — ATH230●●●S6	81

Description

Derating curves for the nominal drive current (I_n) as a function of temperature and switching frequency.

Derating Curves — ATH230●●●M2

ATH230U04M2...ATH230U11M2

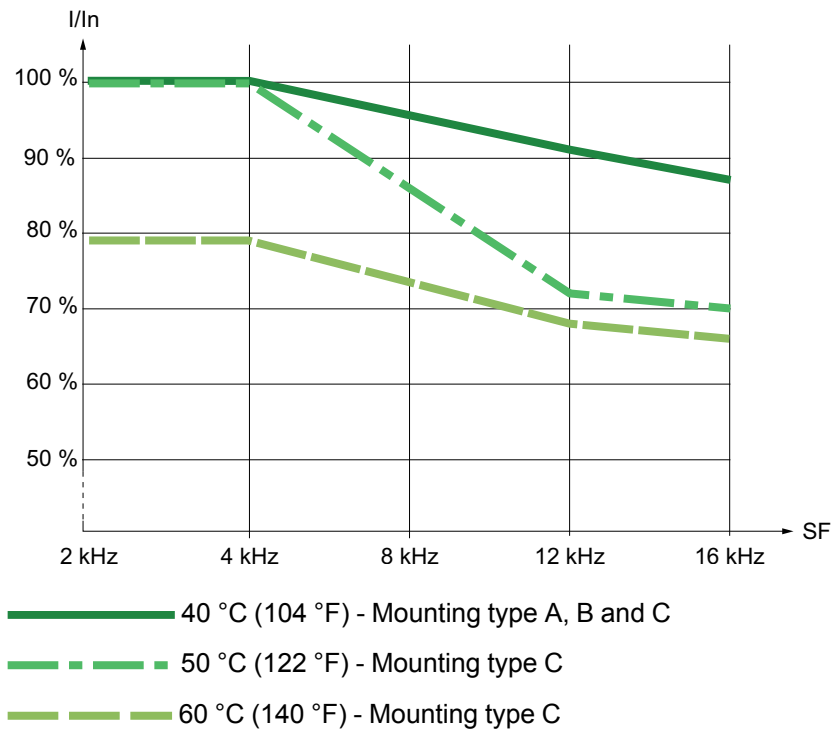

ATH230U15M2...ATH230U22M2

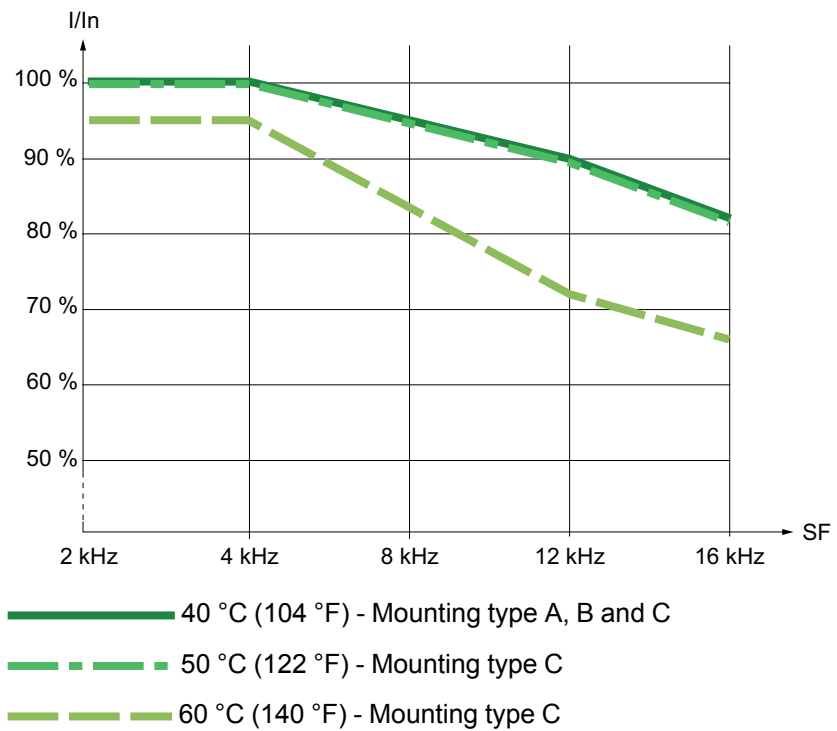

Derating Curves — ATH230●●●M3

ATH230U04M3...ATH230U07M3

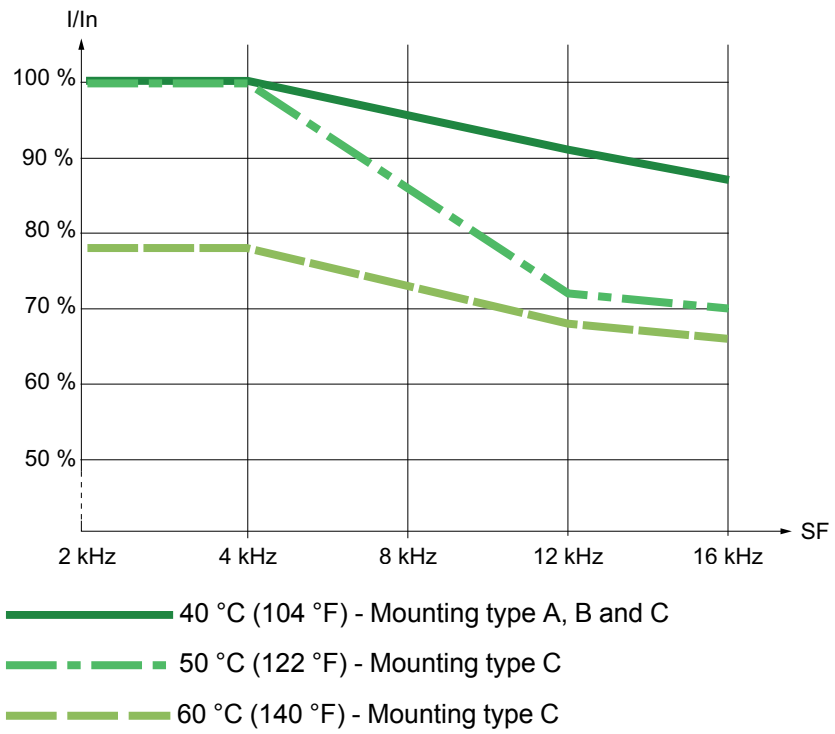

ATH230U11M3...ATH230U22M3

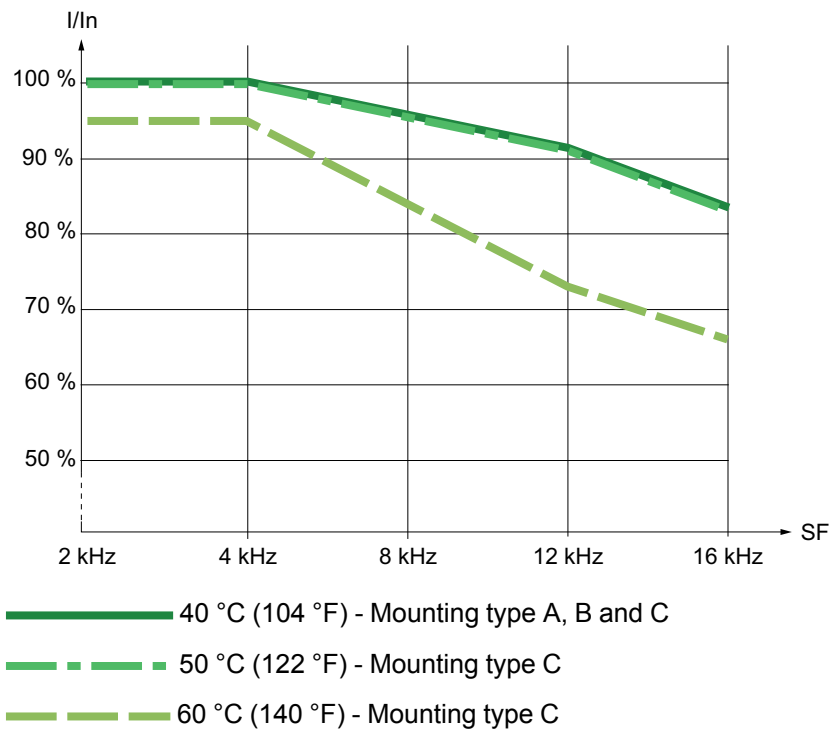

ATH230U30M3...ATH230U40M3

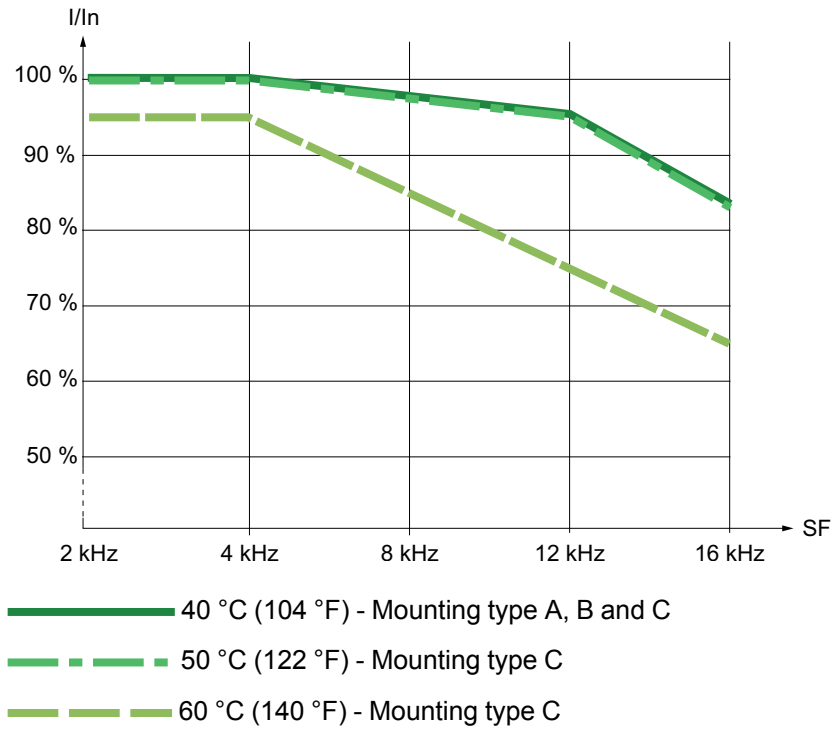

ATH230U55M3 and ATH230U75M3

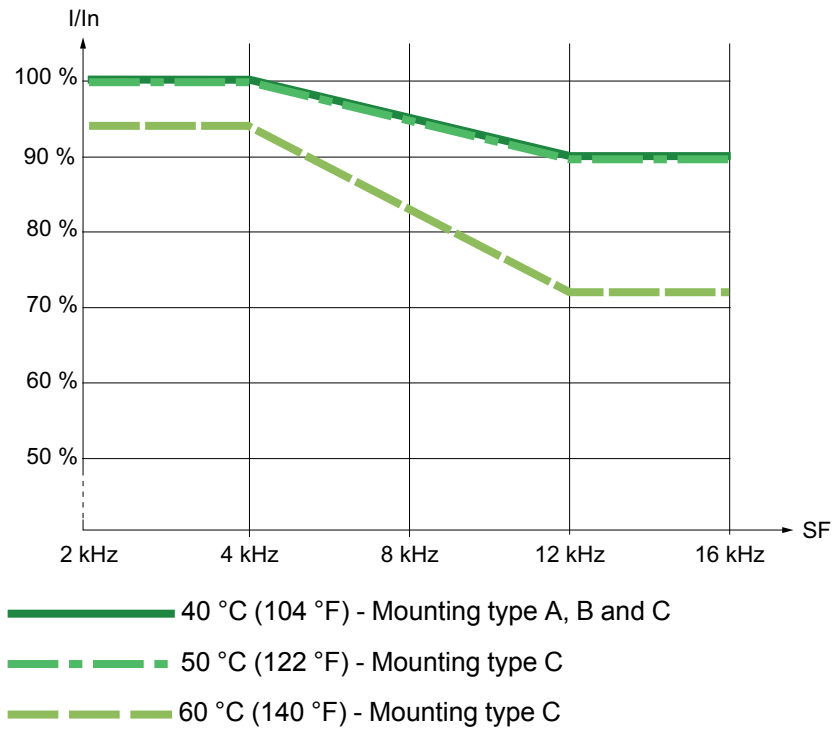

ATH230D11M3 and ATH230D15M3

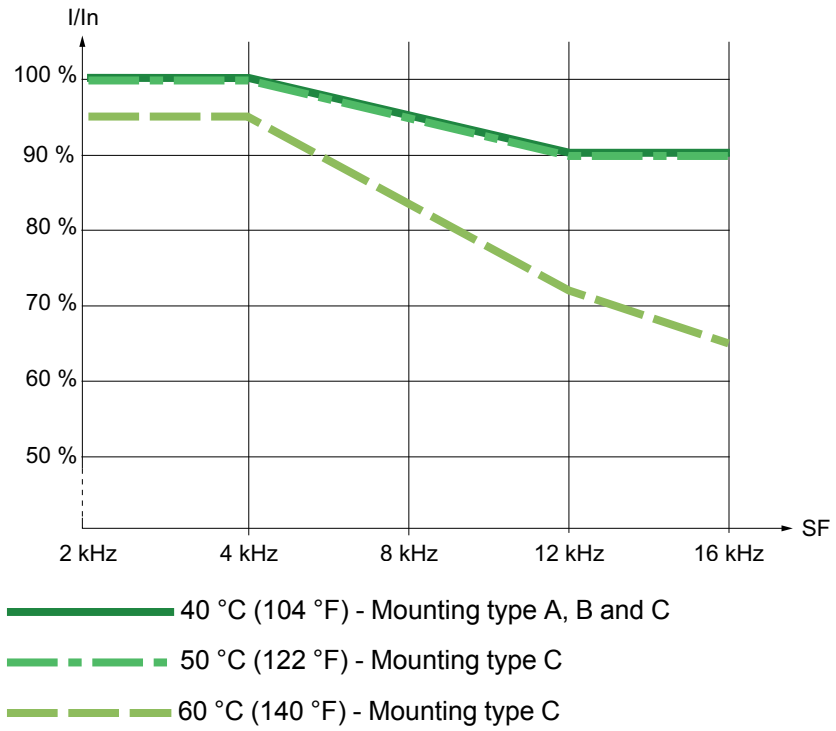

Derating Curves — ATH230●●●N4

ATH230U06N4...ATH230U15N4

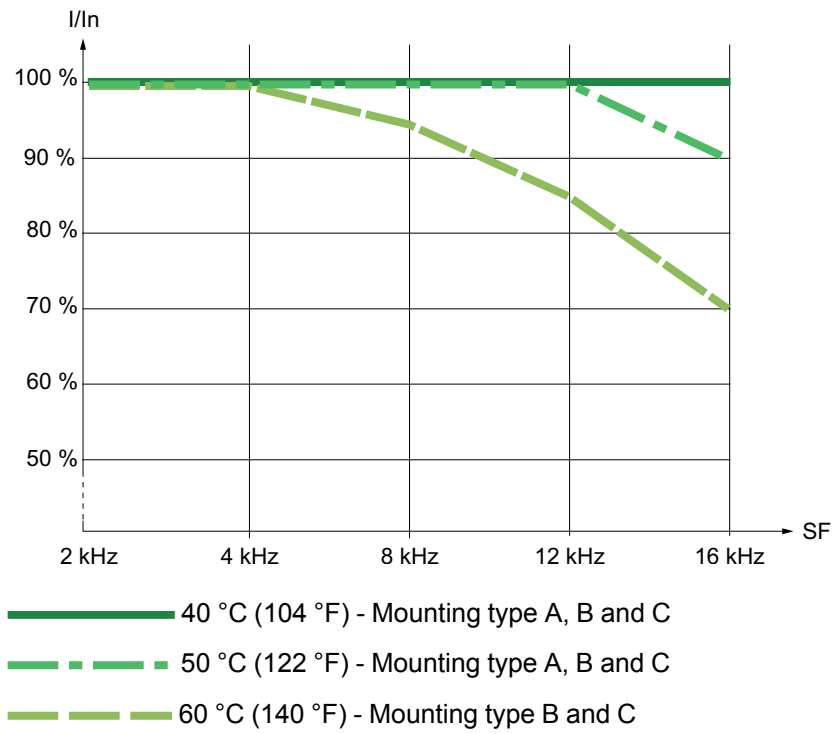

ATH230U22N4...ATH230U40N4

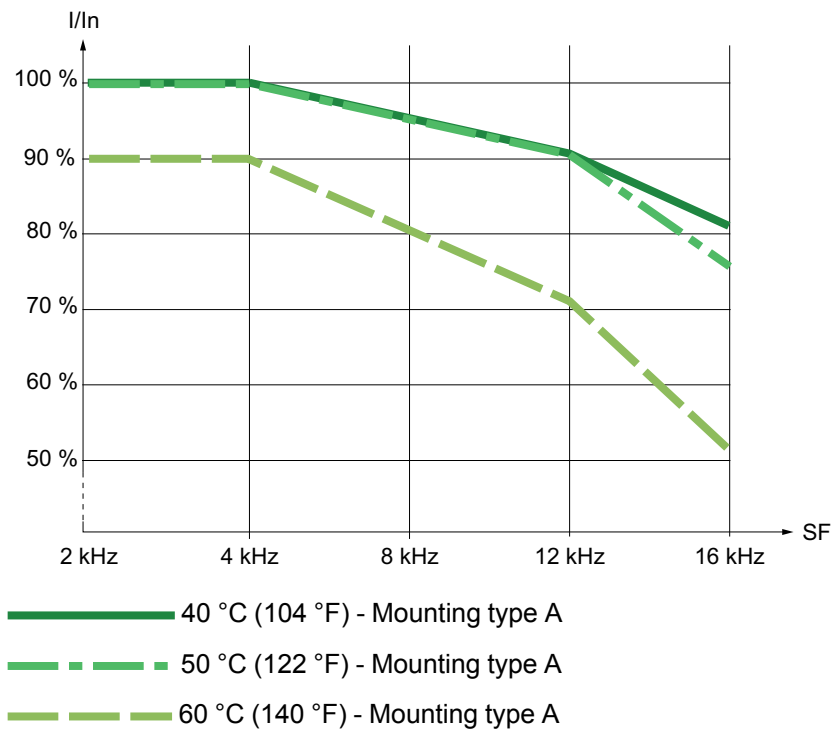

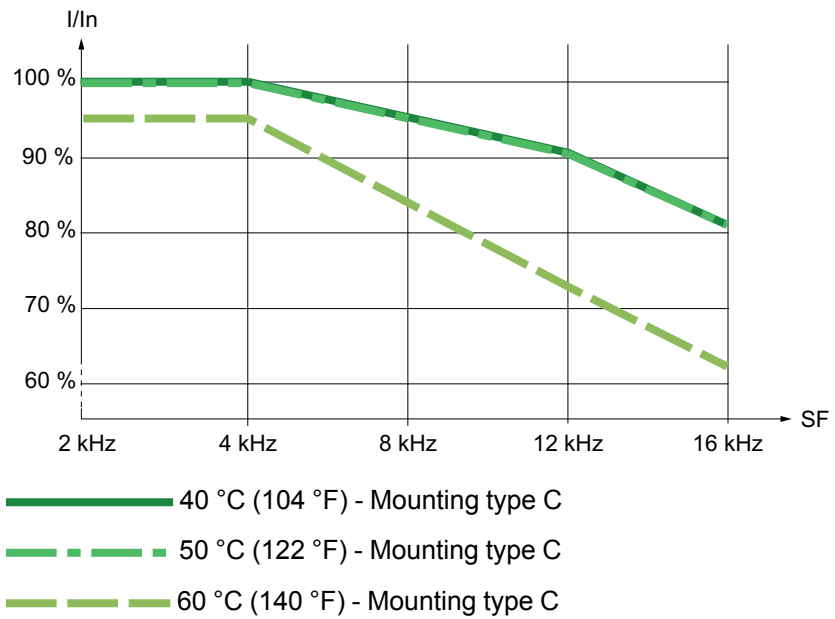
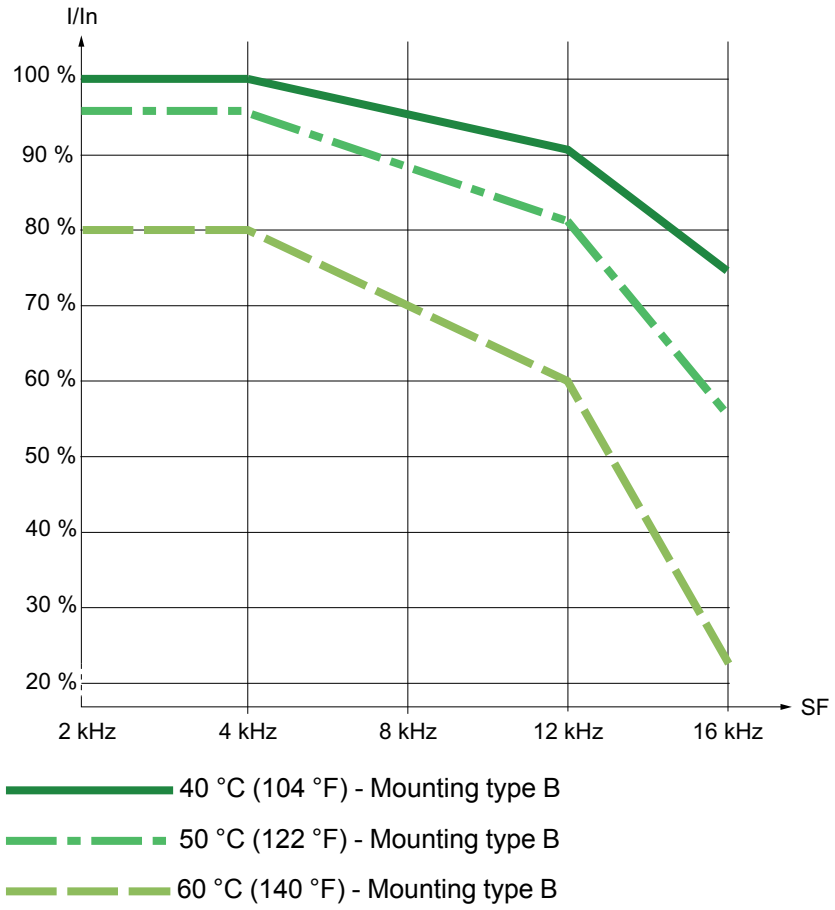

ATH230U55N4 and ATH230U75N4

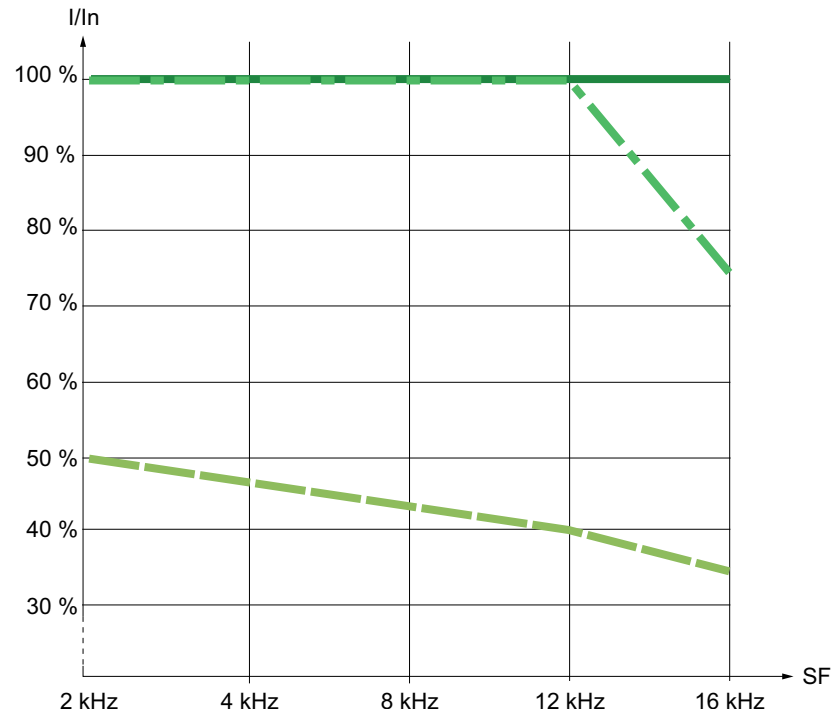

- 40 °C (104 °F) - Mounting type A
- - 50 °C (122 °F) - Mounting type A
- . 60 °C (140 °F) - Mounting type A

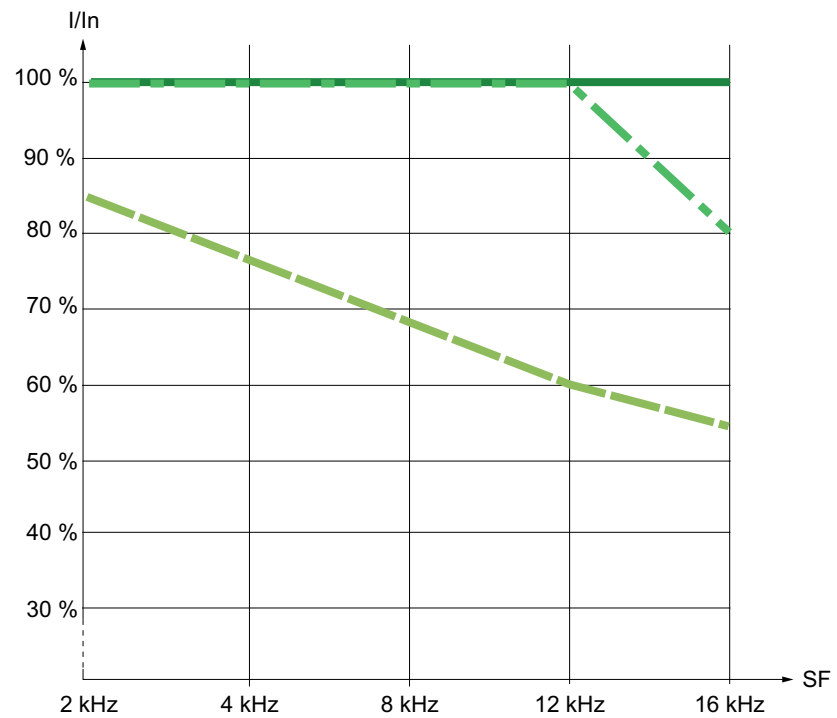

- 40 °C (104 °F) - Mounting type B
- - 50 °C (122 °F) - Mounting type B
- . 60 °C (140 °F) - Mounting type B

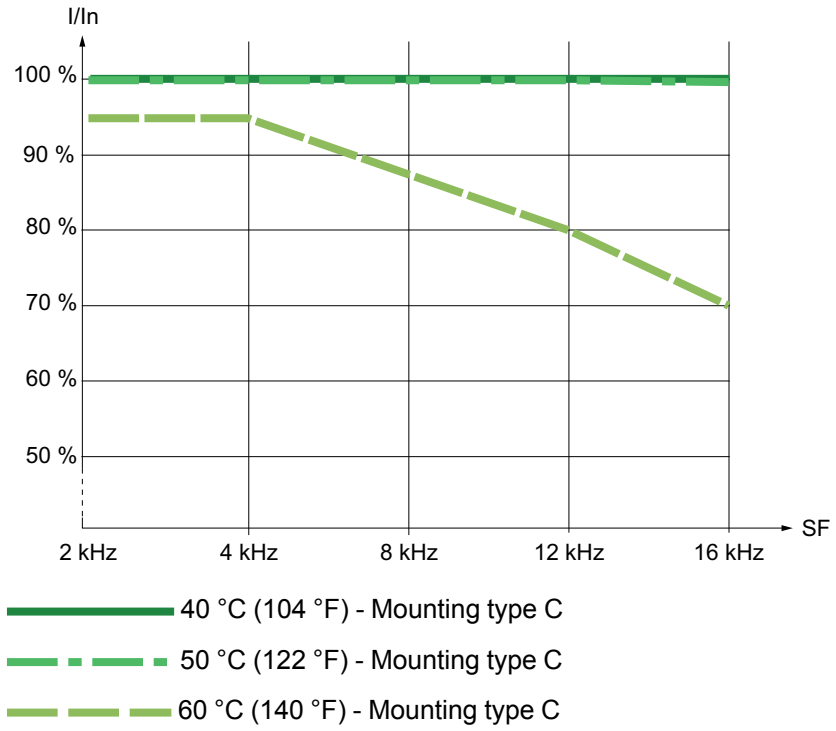

ATH230D11N4 and ATH230D15N4

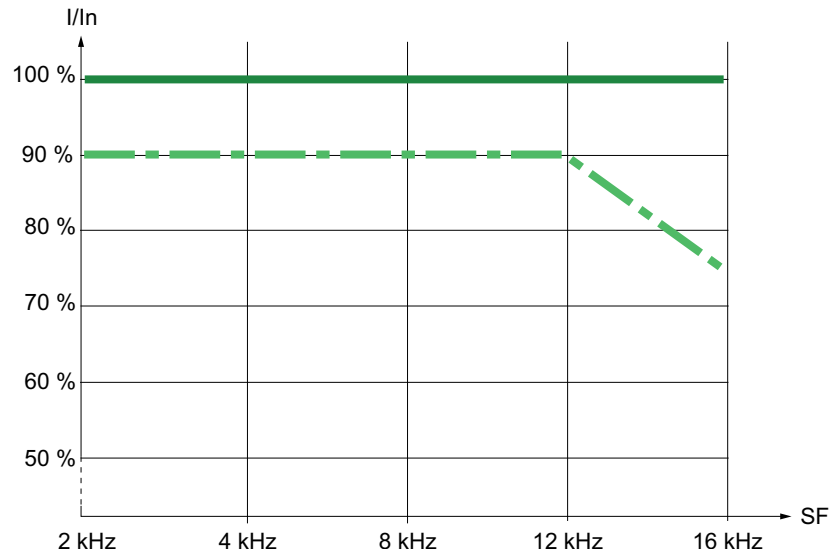

- 40 °C (104 °F) - Mounting type A and B
- - 50 °C (122 °F) - Mounting type A and B

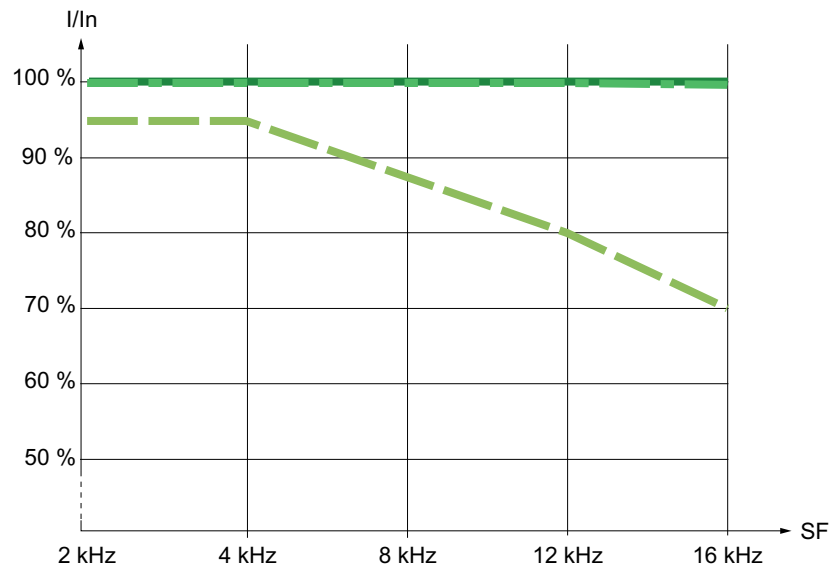

- 40 °C (104 °F) - Mounting type C
- - 50 °C (122 °F) - Mounting type C
- . 60 °C (140 °F) - Mounting type C

ATH230D18N4, ATH230D22N4

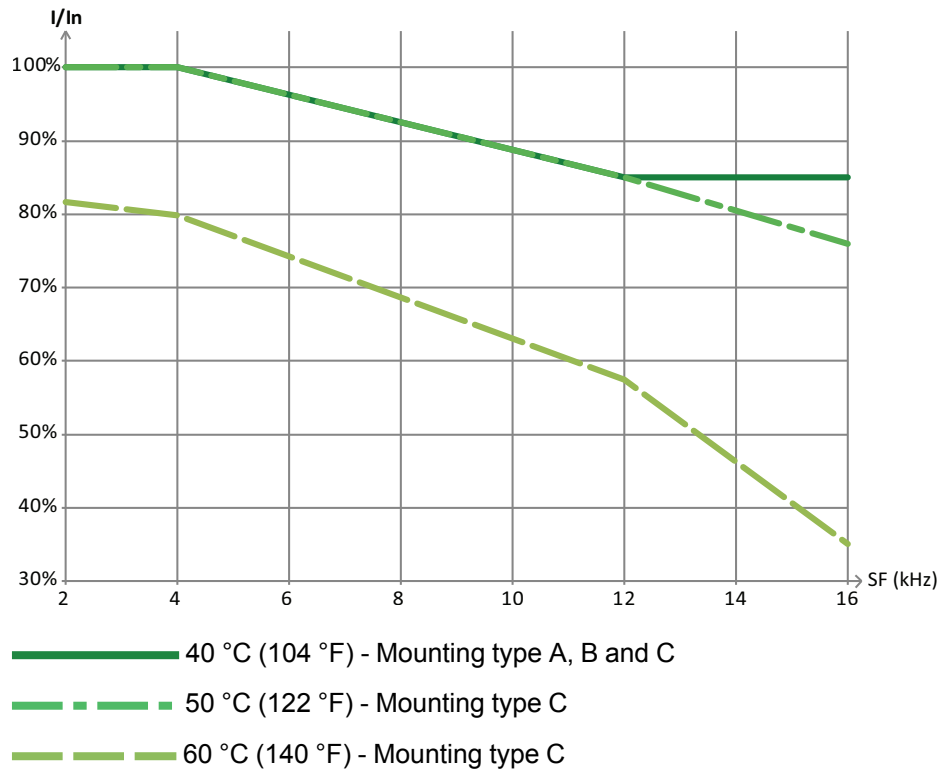

Derating Curves — ATH230●●●S6

ATH230U15S6

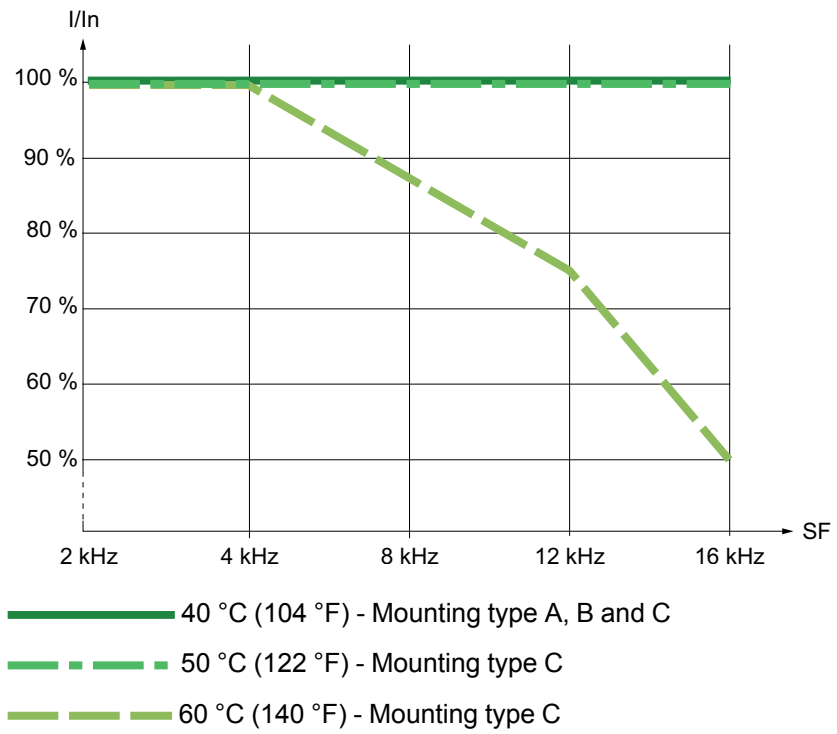

ATH230U22S6 and ATH230U40S6

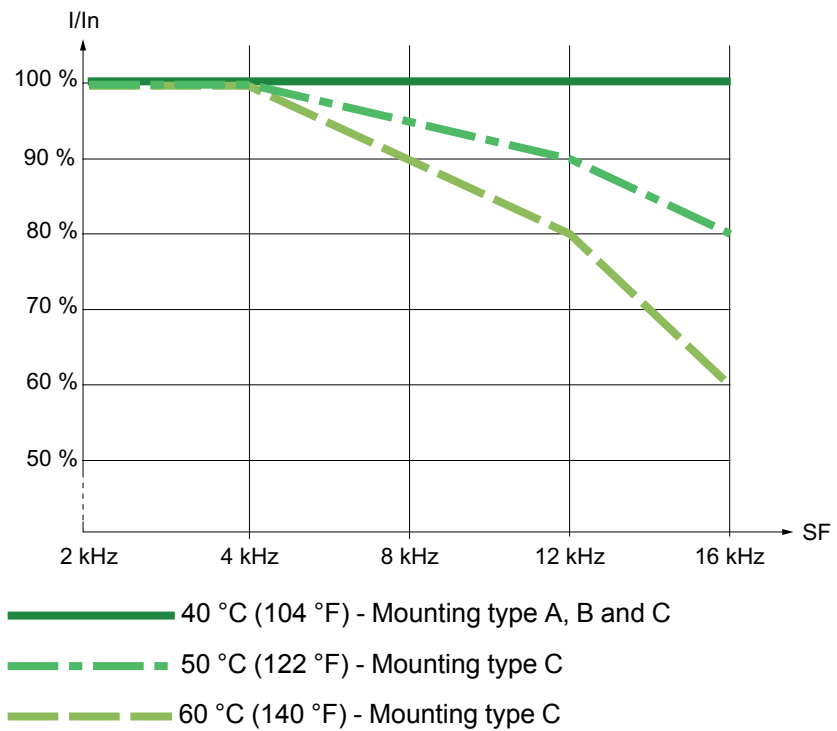

ATH230U55S6 and ATH230U75S6

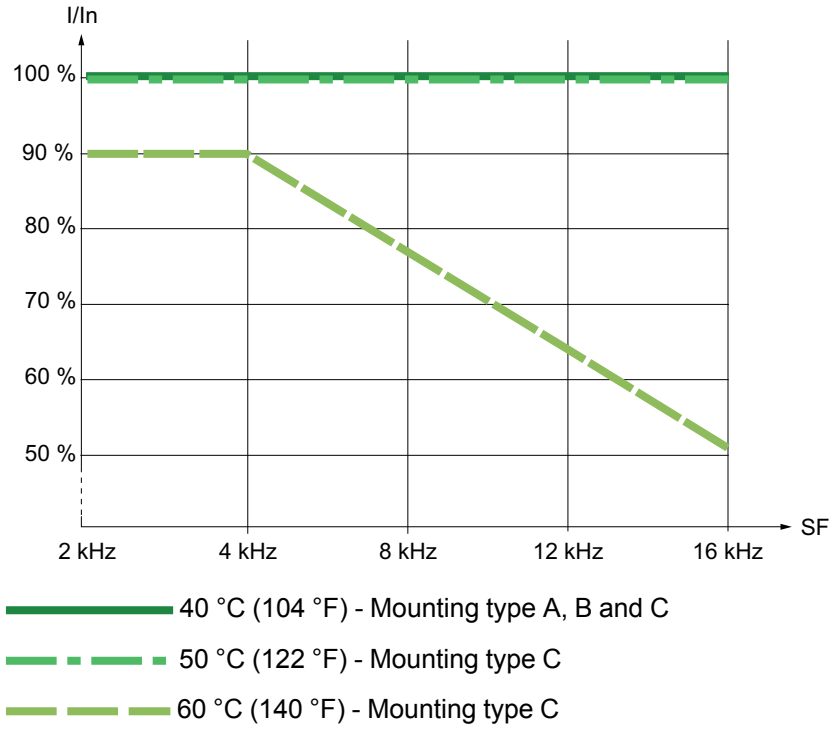

ATH230D11S6 and ATH230D15S6

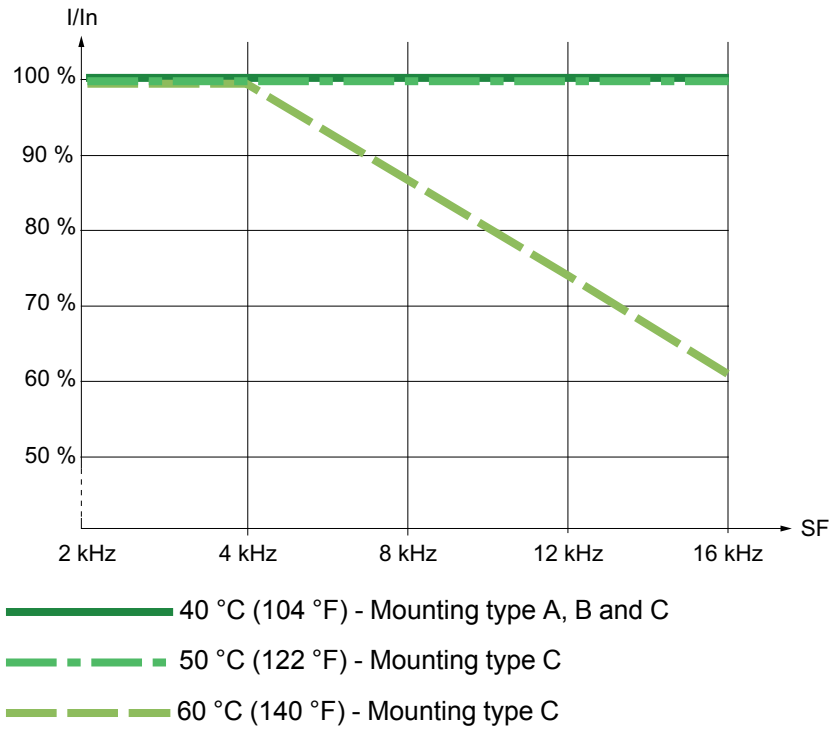

Checking mechanical installation before wiring

Verify the mechanical installation of the entire system:

Step	Action	✓
1	Does the device is mounted in a vertical position at $\pm 10^\circ$?	
2	Does the installation meet the specified distance requirements? NOTE: Adhere to the minimum installation distances for required cooling.	
3	Does the device is mounted on a flat, solid and vibration-free surface?	
4	Does the device is installed indoors, away from heat sources and away from flammable materials.? NOTE: Avoid environmental effects like high temperatures and high humidity as well as dust, dirt and conductive gases.	
5	Does the device is attached to the mounting surface using screws and washers according to the tables shown within the Mounting Holes and Screws, page 65?	
6	Does the fastening screws are tightened to the torque specified in the Mounting Holes and Screws, page 65.	

NOTE: A complete check-list is available here: [Checking mechanical installation before wiring, page 84.](#)

Drive wiring

What's in This Part

Wiring Instructions.....	86
Cable Length Instructions	90
General Wiring Diagrams.....	92
Relay Contacts Wiring	95
Operation on an IT or Corner Grounded System	99
Disconnecting the Built-in EMC Filter	100
Sink / Source Switch Configuration	105
Characteristics of the Power Part Terminals.....	107
Wiring the Power Part.....	114
EMC plate assembly fitting.....	127
Electromagnetic Compatibility	130
Control Terminals Electrical Data.....	133
Arrangement and Characteristics of Control Block Terminals and Communication and I/O Ports.....	136
Wiring The Control Part	138

Wiring Instructions

General Instructions

The entire installation procedure must be performed without voltage present.

DANGER

HAZARD OF ELECTRIC SHOCK, EXPLOSION OR ARC FLASH

Read and understand the instructions in **Product Related Information** chapter before performing any procedure in this chapter.

Failure to follow these instructions will result in death or serious injury.

DANGER

HAZARD OF ELECTRIC SHOCK, EXPLOSION, OR ARC FLASH

Before applying voltage to and configuring the product, verify that it is properly wired.

Failure to follow these instructions will result in death or serious injury.

The product has a leakage current greater than 3.5 mA. If the protective ground connection is interrupted, a hazardous touch current may flow if the product is touched.

DANGER

ELECTRIC SHOCK CAUSED BY HIGH LEAKAGE CURRENT

Verify compliance with all local and national electrical code requirements as well as all other applicable regulations with respect to grounding of the entire drive system installation.

Failure to follow these instructions will result in death or serious injury.

Drive systems may perform unexpected movements because of incorrect wiring, incorrect settings, incorrect data or other errors.

WARNING

UNANTICIPATED EQUIPMENT OPERATION

- Carefully install the wiring in accordance with the EMC requirements.
- Do not operate the product with unknown or unsuitable settings or data.
- Perform a comprehensive commissioning test.

Failure to follow these instructions can result in death, serious injury, or equipment damage.

Cable Characteristics

Only use cables with insulator heat resistance of 75°C (167°F) min.

If you are using cables longer than 50 m (164 ft) between the drive and the motor, add output filters (for more details refer to the catalog).

Use a shielded cable to meet the requirements of Category C2 or C3 according to the standard IEC 61800-3.

To limit the currents in common mode, use common mode output filters (ferrite) in order to reduce the circulating currents in the motor windings.

Standard linear capacity cables can be used with Altivar Machine. Use of cables with lower linear capacity could increase cable length performances.

The overvoltage limitation function **[Motor surge limit.]** S_{UL} enables you to increase the cable length while decreasing the torque performances (refer to Programming manual, page 13).

Residual Current Device

Direct current can be introduced in the protective ground conductor of this device. If a residual current device (RCD / GFCI) or a residual current monitor (RCM) is used for additional protection against direct or indirect contact, the following specific types must be used:

⚠ WARNING

DIRECT CURRENT CAN BE INTRODUCED INTO THE PROTECTIVE GROUND CONDUCTOR

- Use a Type A or Type F Residual Current Device (RCD / GFCI) or a Residual Current Monitor (RCM) for single-phase devices connected to a phase and to the neutral conductor.
- Use a Type B Residual Current Device (RCD / GFCI) or a Residual Current Monitor (RCM) that has approval for use with frequency inverters and is sensitive to all types of current for three-phase devices and for single-phase devices not connected to a phase and the neutral conductor.

Failure to follow these instructions can result in death, serious injury, or equipment damage.

Further conditions for use of a residual current device:

- The device has an increased leakage current at the moment power is applied. Use a residual current device (RCD / GFCI) or a residual current monitor (RCM) with a response delay.
- High-frequency currents must be filtered.

Choose a suitable model integrating:

- High frequency current filtering,
- A time delay that helps to prevent a triggering of the upstream device caused by the load from stray capacitance on power-on. The time delay is not available for 30 mA device; in this case, choose devices with immunity against nuisance triggering.

Due to high leakage current in standard operation, we recommend choosing at least a 300 mA device.

If the installation requires a residual current device less than 300 mA, it can be possible to use a device lower than 300 mA by removing the screws according to the instructions given in the [Operation on an IT or Corner Grounded System](#), page 99.

If the installation includes several drives, provide one residual current device per drive.

Equipment Grounding

⚡ ⚠ DANGER

ELECTRIC SHOCK CAUSED BY INSUFFICIENT GROUNDING

- Verify compliance with all local and national electrical code requirements as well as all other applicable regulations with respect to grounding of the entire device.
- Ground the device before applying voltage.
- The cross section of the protective ground conductor must comply with the applicable standards.
- Do not use conduits as protective ground conductors; use a protective ground conductor inside the conduit.
- Do not consider cable shields to be protective ground conductors.

Failure to follow these instructions will result in death or serious injury.

Tighten the grounding screws according to the instructions given in the Characteristics of the Power Part Terminals, page 107.

Connection Instructions

The product has a leakage current greater than 3.5 mA. If the protective ground connection is interrupted, a hazardous touch current may flow if the product is touched.

⚡ ⚠ DANGER

ELECTRIC SHOCK CAUSED BY HIGH LEAKAGE CURRENT

Verify compliance with all local and national electrical code requirements as well as all other applicable regulations with respect to grounding of the entire drive system installation.

Failure to follow these instructions will result in death or serious injury.

- Ensure that the resistance to Ground is 1 Ohm or less.
- When grounding several drives, you must connect each one directly, as shown in the above figure.
- Do not loop Ground cables or connect them in series.

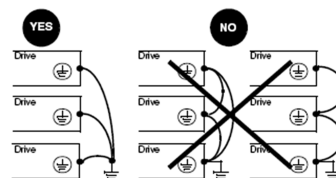

Cable Length Instructions

Long Cable Lengths Consequences

When drives are used with motors, a combination of fast switching transistors and long motor cables can even cause peak voltages up to twice the DC link voltage. This high peak voltage can cause premature aging of motor winding insulation which leads to motor breakdown.

The overvoltage limitation function will enable to increase the cable length while decreasing the torque performances.

Length Of Motor Cables

Because of the permitted mains disturbances, the allowed overvoltages at the motor, the occurring bearing currents and the permitted heat losses the distance between inverter and motor(s) is limited.

The maximum distance heavily depends on the used motors (insulation material), the type of motor cable used (shielded / unshielded), the cable laying (cable channel, underground installation...) as well as from the used options.

Dynamic Voltage Load Of The Motor

Overvoltages at the motor terminals result from reflection in the motor cable. Basically the motors are stressed with measurable higher voltage peaks from a motor cable length of 10 m. With the length of the motor cable also the value of overvoltage increases.

The steep edges of the switching impulses at the output side of the frequency inverter lead to a further load of the motors. The slew rate of the voltage is typically over 5 kV/ μ s but it decreases with the length of the motor cable

Load of the motor with overvoltage and slew rate when using conventional drive

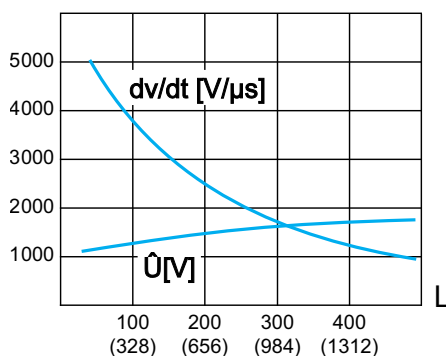

L Length of motor cables in meters (feet)

Corrective Actions Overview

A number of simple measures can be taken to help enhance the motor life time:

- Specification of a motor designed for speed drive applications (IEC60034-25 B or NEMA 400 should be prescribed).
- Reduce to a minimum the distance between motor and drive.
- Use unshielded cables.
- Reduce the drive switching frequency (a reduction to 2.5 kHz is advisable.)

Additional Information

Further detailed technical information is available in the following white paper *An Improved Approach for Connecting VSD and Electric Motors* (998-2095-10-17-13AR0_EN) available on www.se.com.

General Wiring Diagrams

Control Block Wiring Diagram

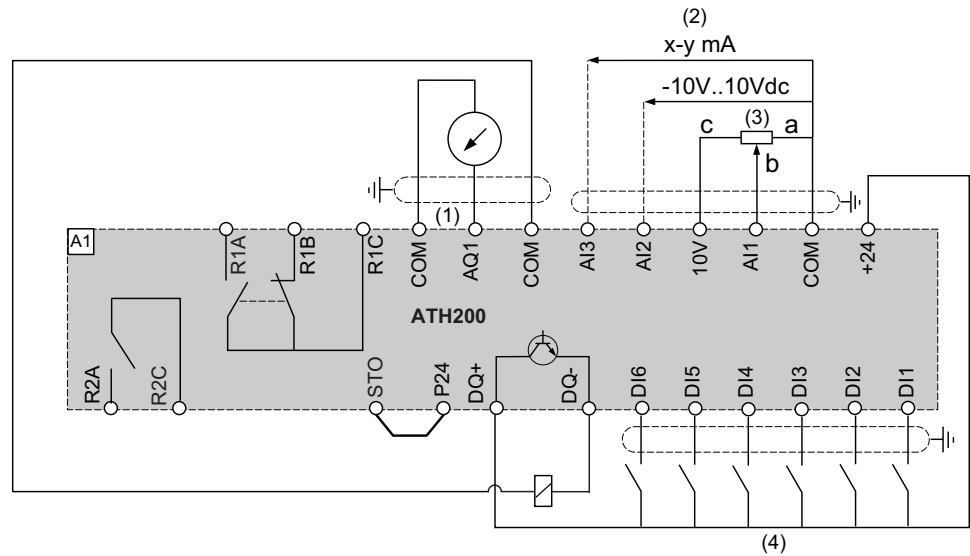

- (1) Analog output
- (2) Analog inputs
- (3) Potentiometer SZ1RV1202 (2.2 kΩ) or similar (10 kΩ maximum)
- (4) Digital Inputs - Shielding instructions are given in the Electromagnetic Compatibility section

Single or Three-phase Power Supply - Diagram With Line Contactor

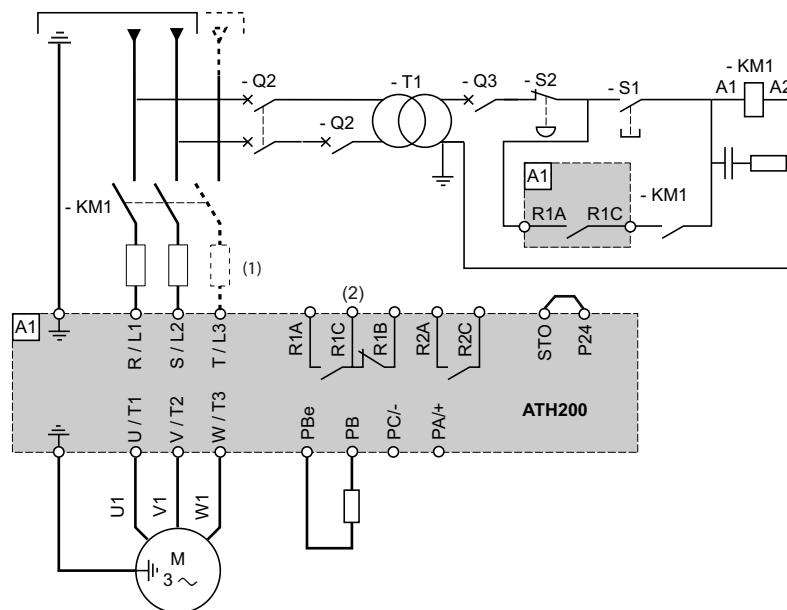

- (1) Line choke (if used).
- (2) Use relay output R1 set to operating state Fault to switch Off the product once an error is detected.

Single or Three-phase Power Supply - Diagram With Downstream Contactor

If a Run command is executed while the downstream contactor between the drive and the motor is still open, there may be residual voltage at the output of the drive. This can cause an incorrect estimation of the motor speed when the contacts of the downstream contactor are closed. This incorrect estimation of the motor speed can lead to unanticipated equipment operation or to equipment damage.

In addition, there may be overvoltage at the output of the drive if the power stage is still enabled when the downstream contactor between the drive and the motor opens.

⚠ WARNING

UNANTICIPATED EQUIPMENT OPERATION OR EQUIPMENT DAMAGE

If a downstream contactor is used between the drive and the motor, verify the following:

- The contacts between the motor and the drive must be closed before a Run command is executed.
- The power stage must not be enabled when the contacts between the motor and the drive open.

Failure to follow these instructions can result in death, serious injury, or equipment damage.

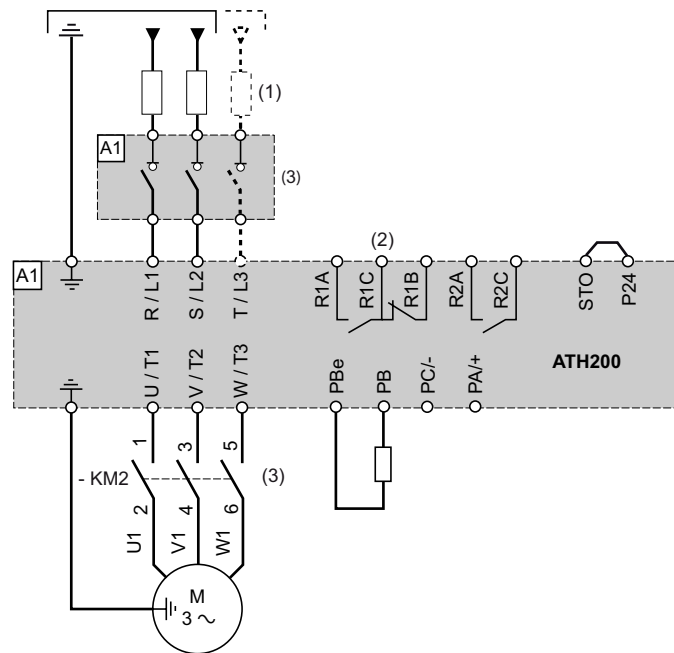

(1) Line choke (if used)

(2) Use relay output R1 set to operating state Fault to switch Off the product once an error is detected.

Sensor Connection

It is possible to connect either 1 sensor on terminals AI2 or AI3 or DI6.

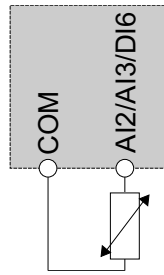

Diagram with Preventa Safety Module

Refer to the ATH200 Safety Functions Manual, page 13.

Relay Contacts Wiring

What's in This Chapter

Output Relay with Inductive AC Loads	96
Output Relay with Inductive DC loads	97

Output Relay with Inductive AC Loads

General

The AC voltage source must be of overvoltage category II (OVC II) according to IEC 61800-5-1.

If it is not the case, an isolation transformer must be used.

Contactors with AC Coil

If controlled by a relay, a resistor-capacitor (RC) circuit must be connected in parallel to the coil of the contactor as shown on the diagram below:

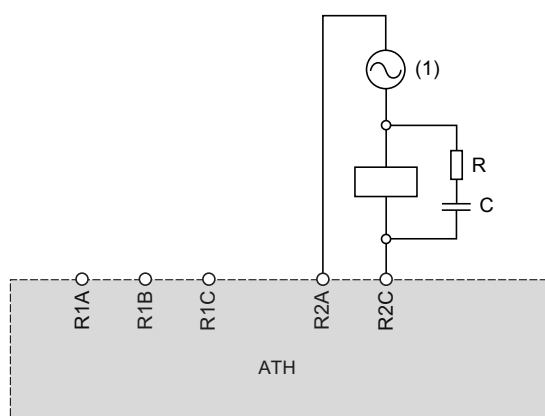

(1) AC 250 Vac maximum.

Schneider Electric AC contactors have a dedicated area on the housing to plug easily the RC device. Refer to the Motor control and protection components catalog MKTED210011EN available on se.com to find the RC device to be associated with the contactor used.

Example: With a 48 Vac source, contactors LC1D09E7 or LC1DT20E7 have to be used with LAD4RCE voltage suppression device.

Other Inductive AC Loads

For other inductive AC loads:

- Use an auxiliary contactor connected on the product to control the load.

Example: with a 48 Vac source, auxiliary contactors CAD32E7 or CAD50E7 with LAD4RCE voltage suppression device.

- When using a third party inductive AC load, request the supplier to provide information on the voltage suppression device, in order to avoid overvoltage above 375 V during relay opening.

Output Relay with Inductive DC loads

Contactors with DC Coil

If controlled by a relay, a bidirectional transient voltage suppression (TVS) diode, also called transil, must be connected in parallel to the coil of the contactor as shown on the diagram below:

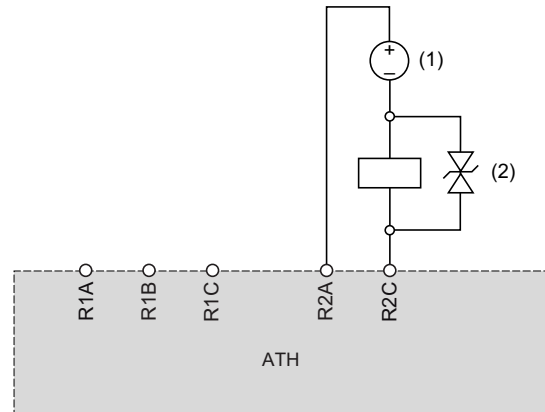

(1) DC 30 Vdc maximum.

(2) TVS diode

Schneider Electric contactors with DC coil include the TVS diode. No additional device is required.

Refer to the Motor control and protection components catalog MKTED210011EN available on se.com for more information.

Other Inductive DC Loads

Other inductive DC loads without embedded TVS diode must use one of the following voltage suppression device:

- A bidirectional TVS device as shown on the diagram above, defined by:
 - TVS break-down voltage greater than 35 Vdc,
 - TVS clamping voltage $V(\text{TVS})$ less than 50 Vdc
 - TVS peak power dissipation greater than load rated current, $I(\text{load}) \times V(\text{TVS})$.

Example: with $I(\text{load}) = 0.9 \text{ A}$ and $V(\text{TVS}) = 50 \text{ Vdc}$, TVS peak power must be greater than 45 W

- TVS average power dissipation greater than the value calculated by the following $0.5 \times I(\text{load}) \times V(\text{TVS}) \times \text{load time constant} \times \text{number of operation per second}$.

Example: with $I(\text{load}) = 0.9 \text{ A}$ and $V(\text{TVS}) = 50 \text{ Vdc}$, load time constant = 40 ms (load inductance divided by load resistance) and 1 operation every 3 s, the TVS average power dissipation must be greater than $0.5 \times 0.9 \times 50 \times 0.04 \times 0.33 = 0.3 \text{ W}$.

- A fly-back diode as shown in the diagram below:

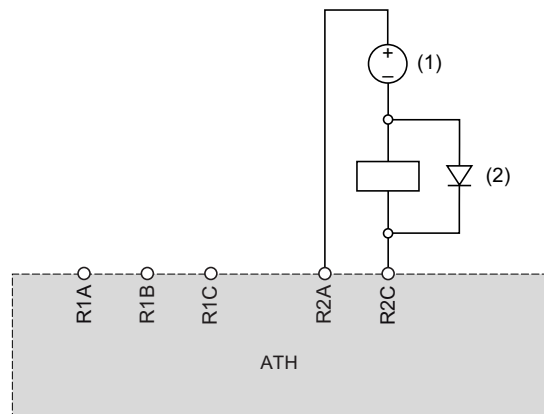

(1) DC 30 Vdc maxi.

(2) Flyback diode

The diode is a polarized device. The fly-back diode must be defined by:

- a reverse voltage greater than 100 Vdc,
- a rated current greater than two times the load rated current,
- a thermal resistance: junction to ambient temperature (in K/W) less than $90 / (1.1 \times I(\text{load}))$ to operate at maximum 60°C (140°F) ambient temperature.

Example: with $I(\text{load}) = 1.5 \text{ A}$, select a 100 V, 3 A rated current diode with a thermal resistance from junction to ambient less than $90 / (1.1 \times 1.5) = 54.5 \text{ K/W}$.

Using a flyback diode, the relay opening time will be longer than with a TVS diode.

NOTE: Use diodes with leads for easy wiring and keep at least 1 cm (0.39 in.) of leads on each side of the case of the diode for a correct cooling.

Operation on an IT or Corner Grounded System

Definition

IT system: Isolated or impedance grounded neutral. Use a permanent insulation monitoring device compatible with nonlinear loads, such as an XM200 type or equivalent.

Corner grounded system: System with one phase grounded.

Operation

NOTICE

OVERVOLTAGE OR OVERHEATING

If the drive is operated via an IT or corner grounded system, the integrated EMC filter must be disconnected as described in the present manual.

Failure to follow these instructions can result in equipment damage.

Disconnecting the Built-in EMC Filter

Filter Disconnection

DANGER

HAZARD OF ELECTRIC SHOCK, EXPLOSION OR ARC FLASH

Read and understand the instructions in **Product Related Information** chapter before performing any procedure in this chapter.

Failure to follow these instructions will result in death or serious injury.

The drives have a built-in EMC filter (*). As a result they exhibit leakage current to ground. If the leakage current creates compatibility problems with your installation (residual current device or other), then you can reduce the leakage current by deactivating the Y capacitors as shown below. In this configuration the product does not meet the EMC requirements according to the standard IEC 61800-3.

(*): Except ATH230•••M3 drives (for 3-phase 200...240 V supply mains) and ATH230•••S6 drives (for 3-phase 525...600 V supply mains).

Setting

This table shows the setting according to the drives:

Drive type	Ratings	Setting
ATH230	1-phase 240 V up to 2.2 kW	IT jumper
	3-phase 400 V up to 4 kW	Screw
	3-phase 240 V ⁽¹⁾	–
	3-phase 400 V 5.5 kW...15 kW	IT jumper
	3-phase 400 V 18.5 kW... 22 kW	Screw
	3-phase 600 V ⁽¹⁾	–
(1) These drives do not include an EMC filter.		

Setting on ATH230U02M2...U07M2 drives

Apply the following instructions to set the drive to operate or not on an IT or Corner grounded system:

Step	Action
1	Remove the power terminal cover , page 115
2	The switch is factory set to the  position shown on detail ①
3	To disconnect the built-in EMC filter position the switch as shown on detail ②
4	Refit the front cover

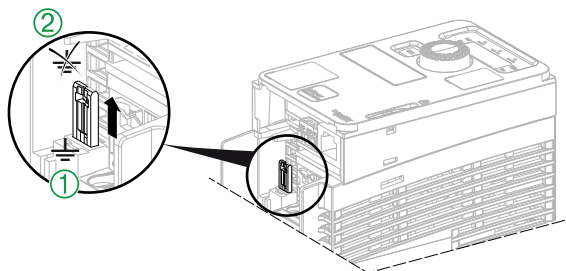

Setting on ATH230U11M2...U22M2 drives

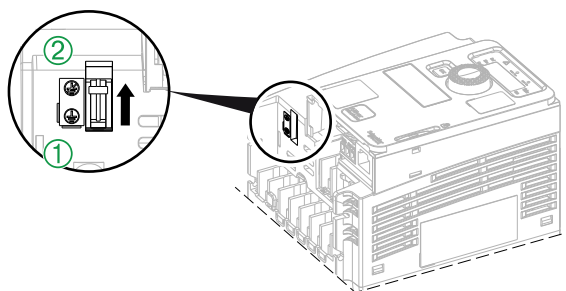

Apply the following instructions to set the drive to operate or not on an IT or Corner grounded system:

Step	Action
1	Remove the power terminal cover , page 117
2	The switch is factory set to the  position shown on detail ①
3	To disconnect the built-in EMC filter position the switch as shown on detail ②
4	Refit the front cover



Setting on ATH230U04N4...U15N4 drives

Apply the following instructions to set the drive to operate or not on an IT or Corner grounded system:

Step	Action
1	Remove the power terminal cover , page 117
2	The screw is factory set to the  position as shown on detail ①
3	To disconnect the built-in EMC filter, remove the screw from its location and set it to the  position as shown on detail ②
4	Refit the front cover

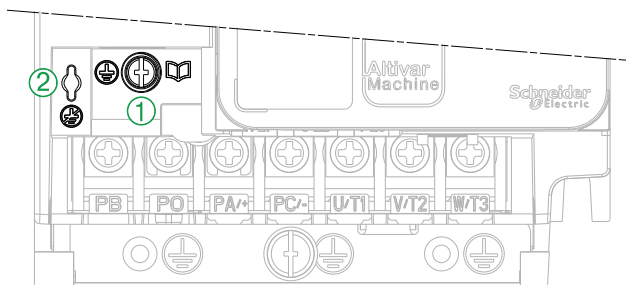

NOTE:

- Use only the screw supplied.
- Do not operate the drive with setting screw removed.



Setting on ATH230U22N4...U40N4 drives

Apply the following instructions to set the drive to operate or not on an IT or Corner grounded system:

Step	Action
1	Remove the power terminal cover , page 119
2	The screw is factory set to the  position as shown on detail ①
3	To disconnect the built-in EMC filter, remove the screw from its location and set it to the  position as shown on detail ②
4	Refit the front cover

NOTE:

- Use only the screw supplied.
- Do not operate the drive with setting screw removed.

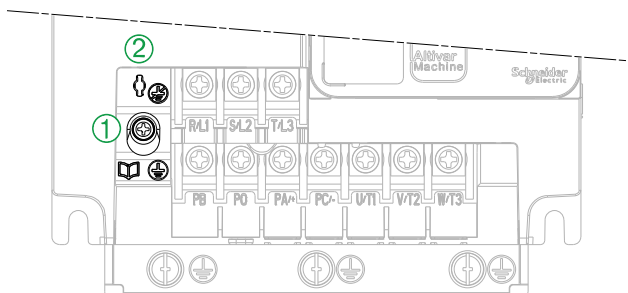

Setting on ATH230U55N4...D15N4 drives

On frame sizes 4C and 5C, the IT jumper is located on front side, behind the power terminals protective cover, on the left-hand side of the power input terminals.

Apply the following instructions to set the drive to operate or not on an IT or Corner grounded system:

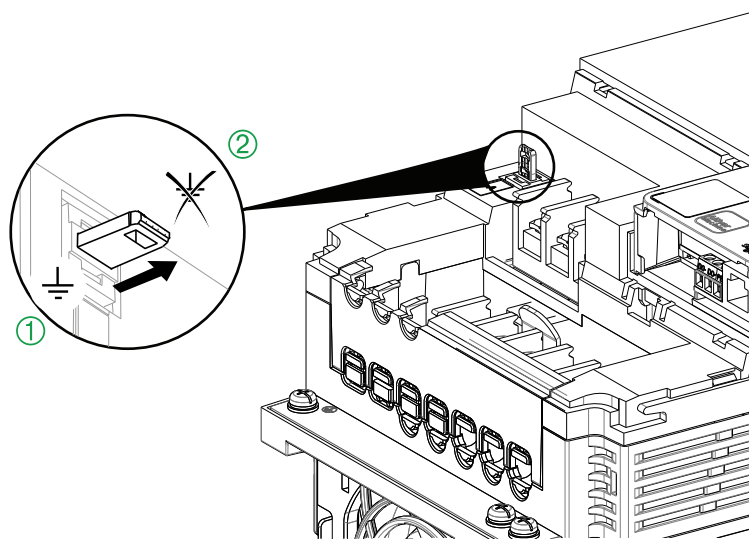

Step	Action
1	Remove the terminal cover , page 123
2	The switch is factory set to the  position shown on detail ①
3	To disconnect the built-in EMC filter position the switch as shown on detail ②
4	Refit the terminal cover



Setting on ATH230D18N4 and ATH230D22N4 drives

On frame size 6C, the screw is located on the front side, behind the power terminals protective cover, on the left-hand side of the power input terminals.

Apply the following instructions to set the drive to operate or not on an IT or Corner grounded system.

Step	Action
1	Remove the power front cover , page 125
2	The screw is factory set to the  position shown on detail ①
3	To disconnect the built-in EMC filter, remove the screw from its location and set it to the  position as shown on detail ②
4	Refit the front cover

NOTE:

- Use only the screw supplied.
- Do not operate the drive with setting screw removed.

Grounding

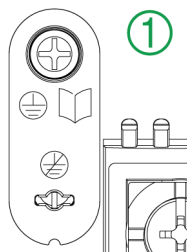

No grounding



Sink / Source Switch Configuration

⚠ WARNING

UNANTICIPATED EQUIPMENT OPERATION

- If the device is set to **Sink Int** or **Sink Ext**, do not connect the **0 V** terminal to ground or to protective ground.
- Verify that accidental grounding of digital inputs configured for sink logic, caused, for example, by damage to the signal cables, cannot occur.
- Follow all applicable standards and directives such as NFPA 79 and EN 60204 for proper control circuit grounding practices.

Failure to follow these instructions can result in death, serious injury, or equipment damage.

The switch is used to adapt the operation of the logic inputs to the technology of the programmable controller outputs. To access the switch, follow *Wiring the Power Part*, page 114. The switch is located below the control terminals, page 136.

- Set the switch to Source (factory setting) if using PLC outputs with PNP transistors.
- Set the switch to Ext if using PLC outputs with NPN transistors.

Switch Set to SRC (Source) Position Using the Output Power Supply for the Digital Inputs

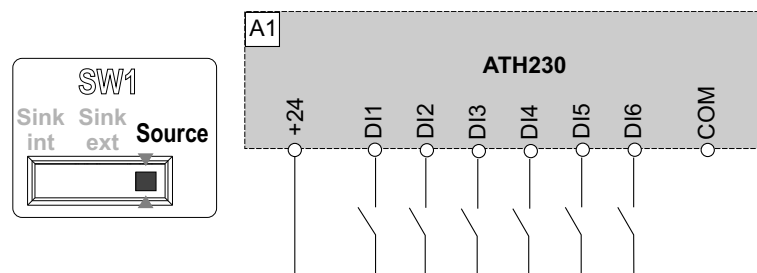

Switch Set to SRC (Source) Position and Use of an External Power Supply for the Digital Inputs

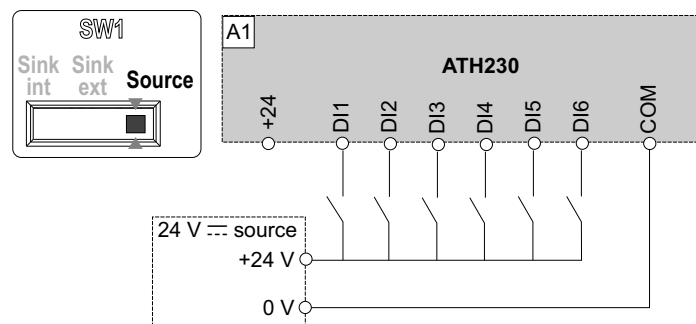

Switch Set to SK (Sink) Position Using the Output Power Supply for the Digital Inputs

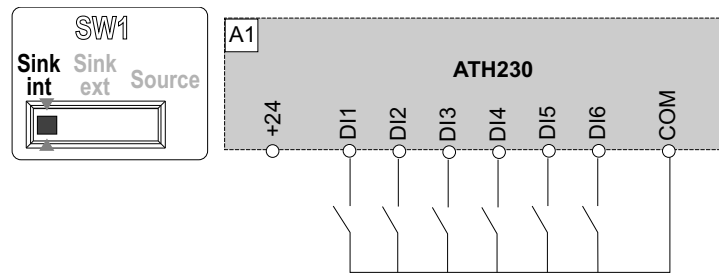

Switch Set to EXT Position Using an External Power Supply for the Digital Inputs

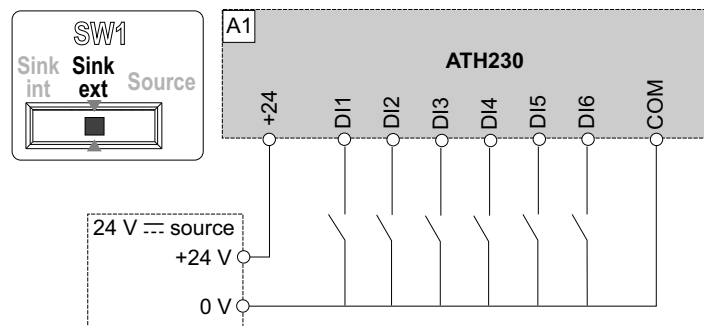

NOTE:

- STO input is also connected by default on a 24 Vdc terminal. If the external power supply is switched off, the function STO will be triggered.
- To avoid triggering the STO function when switching-on the product, the external power supply must be previously switched on.

Characteristics of the Power Part Terminals

⚡⚡ DANGER

HAZARD OF FIRE OR ELECTRIC SHOCK

- Wire cross sections and tightening torques must comply with the specifications provided in this document.
- If you use flexible multi-wire cables for a connection with a voltage higher than 25 Vac, you must use ring type cable lugs or wire ferrules, depending on the wire gauge and the specified stripping length of the cable.

Failure to follow these instructions will result in death or serious injury.

Impact wrench cannot be used to ensure correct tightening torque and can cause damage to the fastener and/or equipment.

Ground Cables

⚡⚡ DANGER

ELECTRIC SHOCK CAUSED BY INSUFFICIENT GROUNDING

- For the protective earth conductor connected to the grounding screw, verify that the minimum cross section is compliant with the next table.
- Verify compliance with all local and national electrical code requirements as well as all other applicable regulations with respect to grounding of the entire drive system.

Failure to follow these instructions will result in death or serious injury.

Cross-sectional area of phase conductors of the product S (mm ²) (for copper cables)	Minimum cross-sectional area of the corresponding protective earthing conductor Sp (mm ²) (for copper cables)
$S \leq 10$	10
$10 < S \leq 16$	S
$16 < S \leq 35$	16
$35 < S$	S/2

Ground Terminals Screws Tightening Torques

Tightening torques according to frame size

- Frame sizes 1, 2:
 - Main grounding screw (M5): 2.4 N·m (21.1 lb·in)
 - Input/Output grounding screws (M4): 1.4 N·m (12.4 lb·in)
- Frame size 3, 4, 5:
 - 2.4 N·m (21.1 lb·in)

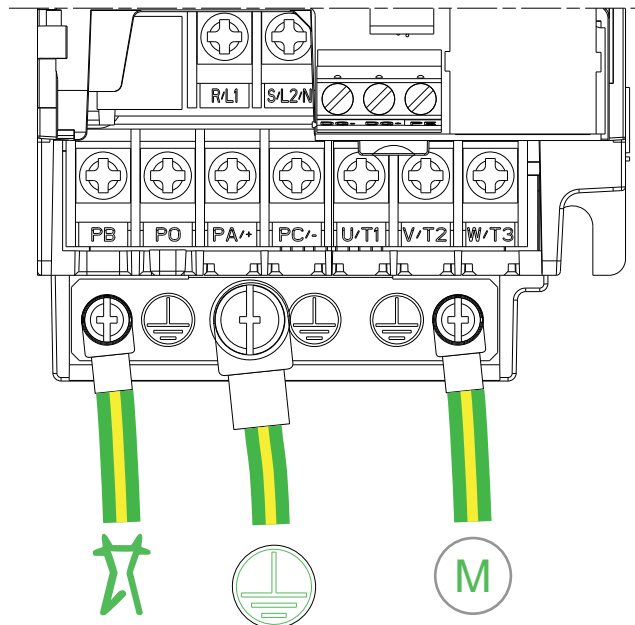

Cross Section: Electrical and Mechanical characteristics

⚡⚠ DANGER

HAZARD OF FIRE OR ELECTRIC SHOCK

If the product is used below its rated power and you choose to reduce the wire cross section compared to the specified minimum wire cross section given at rated condition, ensure that the selected wire cross section is compliant with the duty cycle and current load of the application.

Failure to follow these instructions will result in death or serious injury.

Frame Size 1

Electrical characteristics (*)

ATH230	Minimum Wire Cross Section at rated condition		
	Supply Terminals (L1, L2, L3, PE)	Output Terminals (U, V, W, PE)	DC Bus Terminals (**) (PA/+, PC/-)
	mm ² (AWG)	mm ² (AWG)	mm ² (AWG)
U04M●...U07M●	2.5 (14)	2.5 (14)	2.5 (14)
(*) Minimum wire cross section to be applied when the product is used at rated power.			
(**) Wire cross section in case of DC bus voltage supply			

Mechanical characteristics

ATH230	Supply Terminals (L1, L2, L3, PE) Output Terminals (U, V, W, PE) DC Bus Terminals (PA/+, PC/-) (***)		
	Minimum Permissible Cross Section (*) (**)	Maximum Permissible Cross Section	Rated Tightening Torque
	mm ² (AWG)	mm ² (AWG)	N·m (lb.in)
U04M●...U07M●	0.5 (22)	4 (12)	1 (8.9)
(*) The mechanical characteristics concern power terminal only and do not take into account the cabling equipment (cable clamp, cable gland,...) that are designed for the rated conditions. (**) Minimum permissible cross section are provided, if the product is used below its rated power. In this case, ensure that the wire cross section is compliant with the duty cycle and current load. (***) Wire cross section in case of DC bus voltage supply			

NOTE: Only use cables with solid wires or rigid stranded wires.

Frame Size 2

Electrical characteristics (*)

ATH230	Minimum Wire Cross Section at rated condition		
	Supply Terminals (L1, L2, L3, PE)	Output Terminals (U, V, W, PE)	DC Bus Terminals (**) (PA/+, PC/-)
	mm ² (AWG)	mm ² (AWG)	mm ² (AWG)
U11M2	4 (12)	2.5 (14)	2.5 (14)
U15M2	6 (10)	2.5 (14)	4 (12)
U22M2	6 (10)	2.5 (14)	6 (10)
U11M3, U15M3	2.5 (14)	2.5 (14)	2.5 (14)
U22M3	4 (12)	2.5 (14)	4 (12)
U06N4...U15N4 U15S6	2.5 (14)	2.5 (14)	2.5 (14)
(*) Minimum wire cross section to be applied when the product is used at rated power. (**) Wire cross section in case of DC bus voltage supply			

Mechanical characteristics

ATH230	Output Terminals (U, V, W, PE) DC Bus Terminals (PA/+, PC/-) (***) Supply Terminals (L1, L2, L3, PE)		
	Minimum Permissible Cross Section (*) (**)	Maximum Permissible Cross Section	Rated Tightening Torque
	mm ² (AWG)	mm ² (AWG)	N·m (lb.in)
U11M•...U22M• U15S6 U06N4...U15N4	0.5 (22)	6 (10)	1.4 (12.4)
(*) The mechanical characteristics concern power terminal only and do not take into account the cabling equipment (cable clamp, cable gland,...) that are designed for the rated conditions. (**) Minimum permissible cross section are provided, if the product is used below its rated power. In this case, ensure that the wire cross section is compliant with the duty cycle and current load. (***) Wire cross section in case of DC bus voltage supply			

NOTE: Only use cables with solid wires or rigid stranded wires.

Frame Size 3**Electrical characteristics (*)**

ATH230	Minimum Wire Cross Section at rated condition		
	Supply Terminals (L1, L2, L3, PE)	Output Terminals (U, V, W, PE)	DC Bus Terminals (**) (PA/+, PC/-)
	mm ² (AWG)	mm ² (AWG)	mm ² (AWG)
U30M3	6 (10)	4 (12)	6 (10)
U40M3	6 (10)	6 (10)	6 (10)
U22N4, U30N4 U22S6, U40S6	2.5 (14)	2.5 (14)	2.5 (14)
U40N4	4 (12)	2.5 (14)	4 (12)
(*) Minimum wire cross section to be applied when the product is used at rated power. (**) Wire cross section in case of DC bus voltage supply			

Mechanical characteristics

ATH230	Supply Terminals (L1, L2, L3, PE)		
	Output Terminals (U, V, W, PE)		
	DC Bus Terminals (PA/+, PC/-) (***)		
	Minimum Permissible Cross Section (*) (**)	Maximum Permissible Cross Section	Rated Tightening Torque
	mm ² (AWG)	mm ² (AWG)	N·m (lb.in)
U30M3, U40M3 U22N4...U40N4 U22S6, U40S6	0.5 (22)	6 (10)	1.4 (12.4)

(*) The mechanical characteristics concern power terminal only and do not take into account the cabling equipment (cable clamp, cable gland,...) that are designed for the rated conditions.

(**) Minimum permissible cross section are provided, if the product is used below its rated power. In this case, ensure that the wire cross section is compliant with the duty cycle and current load.

(***) Wire cross section in case of DC bus voltage supply

NOTE: Only use cables with solid wires or rigid stranded wires.

Frame Size 4

Electrical characteristics (*)

ATH230	Minimum Wire Cross Section at rated condition		
	Supply Terminals (L1, L2, L3, PE)	Output Terminals (U, V, W, PE)	DC Bus Terminals (**) (PA/+, PC/-)
	mm ² (AWG)	mm ² (AWG)	mm ² (AWG)
U55M3	10 (8)	10 (8)	10 (8)
U75M3	16 (6)	10 (8)	16 (6)
U55N4	6 (10)	4 (12)	6 (10)
U75N4	10 (8)	6 (10)	10 (8)
U55S6, U75S6	2.5 (14)	2.5 (14)	2.5 (14)

(*) Minimum wire cross section to be applied when the product is used at rated power.

(**) Wire cross section in case of DC bus voltage supply

Mechanical characteristics

ATH230	Supply Terminals (L1, L2, L3, PE)		
	Output Terminals (U, V, W, PE)		
	DC Bus Terminals (PA/+, PC/-) (***)		
	Minimum Permissible Cross Section (*) (**)	Maximum Permissible Cross Section	Rated Tightening Torque
	mm ² (AWG)	mm ² (AWG)	N·m (lb.in)
U55••, U75••	1.5 (14)	16 (6)	2.4 (20.8)

(*) The mechanical characteristics concern power terminal only and do not take into account the cabling equipment (cable clamp, cable gland,...) that are designed for the rated conditions.

(**) Minimum permissible cross section are provided, if the product is used below its rated power. In this case, ensure that the wire cross section is compliant with the duty cycle and current load.

(***) Wire cross section in case of DC bus voltage supply

NOTE: Only use cables with solid wires or rigid stranded wires.

Frame Size 5**Electrical characteristics (*)**

ATH230	Minimum Wire Cross Section at rated condition		
	Supply Terminals (L1, L2, L3, PE)	Output Terminals (U, V, W, PE)	DC Bus Terminals (**) (PA/+, PC/-)
	mm ² (AWG)	mm ² (AWG)	mm ² (AWG)
D11M3	25 (4)	16*2 (6*2)	16*2 (6*2)
D11N4	10 (8)	10 (8)	10 (8)
D15M3	16*2 (6*2)	16*2 (6*2)	16*2 (6*2)
D15N4	16 (6)	10 (8)	16 (6)
D11S6, D15S6	6 (10)	6 (10)	6 (10)

(*) Minimum wire cross section to be applied when the product is used at rated power.

(**) Wire cross section in case of DC bus voltage supply

Mechanical characteristics

ATH230	Supply Terminals (L1, L2, L3, PE) Output Terminals (U, V, W, PE) DC Bus Terminals (PA/+, PC/-) (***)		
	Minimum Permissible Cross Section (*) (**)	Maximum Permissible Cross Section	Rated Tightening Torque
	mm ² (AWG)	mm ² (AWG)	N·m (lb.in)
D11M3, D15M3	2 (12)	16*2 (6*2)	4.5 (40)
D11N4, D15N4 D11S6, D15S6	1.5 (14)	16 (6)	2.4 (20.8)

(*) The mechanical characteristics concern power terminal only and do not take into account the cabling equipment (cable clamp, cable gland,...) that are designed for the rated conditions.

(**) Minimum permissible cross section are provided, if the product is used below its rated power. In this case, ensure that the wire cross section is compliant with the duty cycle and current load. Refer to the [Cable routing section](#).

(***) Wire cross section in case of DC bus voltage supply

NOTE: Only use cables with solid wires or rigid stranded wires.

Frame Size 6

Electrical characteristics (*)

ATH230	Minimum Wire Cross Section at rated condition		
	Supply Terminals (L1, L2, L3, PE)	Output Terminals (U, V, W, PE)	DC Bus Terminals (**) (PA/+, PC/-)
	mm ² (AWG)	mm ² (AWG)	mm ² (AWG)
D18N4, D22N4	25 (4)	16 (6)	25 (4)

(*) Minimum wire cross section to be applied when the product is used at rated power. Refer to the [Cable routing section](#).

(**) Wire cross section in case of DC bus voltage supply

Mechanical characteristics

ATH230	Supply Terminals (L1, L2, L3, PE) Output Terminals (U, V, W, PE) (***) DC Bus Terminals (PA/+, PC/-) (****)		
	Minimum Permissible Cross Section (*) (**)	Maximum Permissible Cross Section	Rated Tightening Torque
	mm ² (AWG)	mm ² (AWG)	N·m (lb.in)
D18N4, D22N4	2 (12)	35 (2)	4.5 (40)

(*) The mechanical characteristics concern power terminal only and do not take into account the cabling equipment (cable clamp, cable gland,...) that are designed for the rated conditions.

(**) Minimum permissible cross section are provided, if the product is used below its rated power. In this case, ensure that the wire cross section is compliant with the duty cycle and current load. Refer to the [Cable routing section](#).

(***) When using an EMC plate, the maximum is 16mm². For more information, refer to [Additional measures for EMC improvement for Frame Size 6, page 132](#).

(****) Wire cross section in case of DC bus voltage supply.

NOTE: Only use cables with solid wires or rigid stranded wires.

Wiring the Power Part

DANGER

HAZARD OF ELECTRIC SHOCK, EXPLOSION OR ARC FLASH

Verify that the cables are properly installed as specified in the Characteristics of the Power Part Terminals section.

Failure to follow these instructions will result in death or serious injury.

DANGER

HAZARD OF FIRE OR ELECTRIC SHOCK

- Wire cross sections and tightening torques must comply with the specifications provided in this document.
- If you use flexible multi-wire cables for a connection with a voltage higher than 25 Vac, you must use ring type cable lugs or wire ferrules, depending on the wire gauge and the specified stripping length of the cable.

Failure to follow these instructions will result in death or serious injury.

Functions of the Power Terminals

Terminal	Function	For
	Ground terminal	All ratings and Frame sizes
R/L1 - S/L2/N	Power supply	ATH230.....M2
R/L1 - S/L2 - T/L3		ATH230.....N4, ATH230.....M3
P0	Output to braking resistor (+ polarity) (1)	ATH230.....
PB	Output to braking resistor (1)	All ratings and Frame sizes
PA/+	DC bus + polarity (1)	Frame sizes 1, 2, 3, 4 and 5
PC/-	DC bus - polarity	Frame sizes 1, 2, 3, 4 and 5
U/T1 - V/T2 - W/T3	Outputs to the motor	All ratings and Frame sizes
<p>(1) For further information about the braking resistor option, please refer to www.se.com.</p> <p>NOTE: Refer to the instruction sheet attached to the braking resistor to do the connection.</p>		

Access To The Terminals For ATH230 Frame Size 1

⚠️⚠️ DANGER

HAZARD OF ELECTRIC SHOCK, EXPLOSION OR ARC FLASH

Read and understand the instructions in **Product Related Information** chapter before performing any procedure in this chapter.

Failure to follow these instructions will result in death or serious injury.

⚠️⚠️ DANGER

HAZARD OF ELECTRIC SHOCK, EXPLOSION, OR ARC FLASH

After wiring the power terminals, refit properly the terminal cover and the wiring cover to meet the required degree of protection.

Failure to follow these instructions will result in death or serious injury.

Power supply terminals, motor terminals and braking resistor terminals are located on the bottom of the drive.

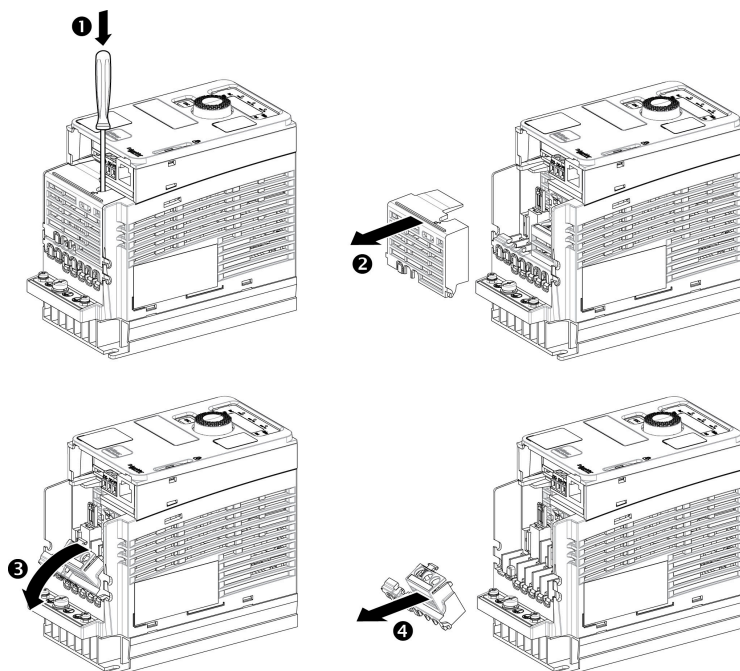

Apply the following instructions to access the power terminals on **frame sizes 1** drives:

Step	Action
1	Push the locking tab using a screwdriver.
2	Remove the wiring cover.
3	Incline the terminal cover
4	Remove the terminal cover

Power Terminals Arrangement For ATH230 Frame Size 1

Single-phase

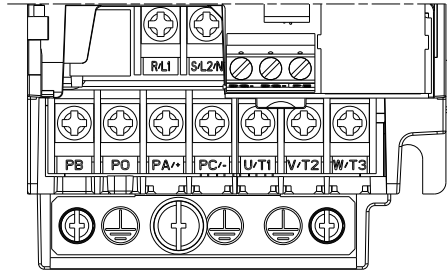

3-phase

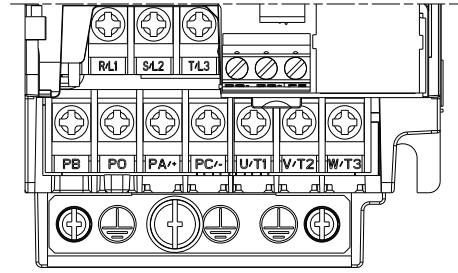

Access To The Terminals For ATH230 Frame Size 2

⚠️⚠️ DANGER

HAZARD OF ELECTRIC SHOCK, EXPLOSION OR ARC FLASH

Read and understand the instructions in **Product Related Information** chapter before performing any procedure in this chapter.

Failure to follow these instructions will result in death or serious injury.

⚠️⚠️ DANGER

HAZARD OF ELECTRIC SHOCK, EXPLOSION, OR ARC FLASH

After wiring the power terminals, refit properly the terminal cover and the wiring cover to meet the required degree of protection.

Failure to follow these instructions will result in death or serious injury.

Power supply terminals, motor terminals and braking resistor terminals are located on the bottom of the drive.

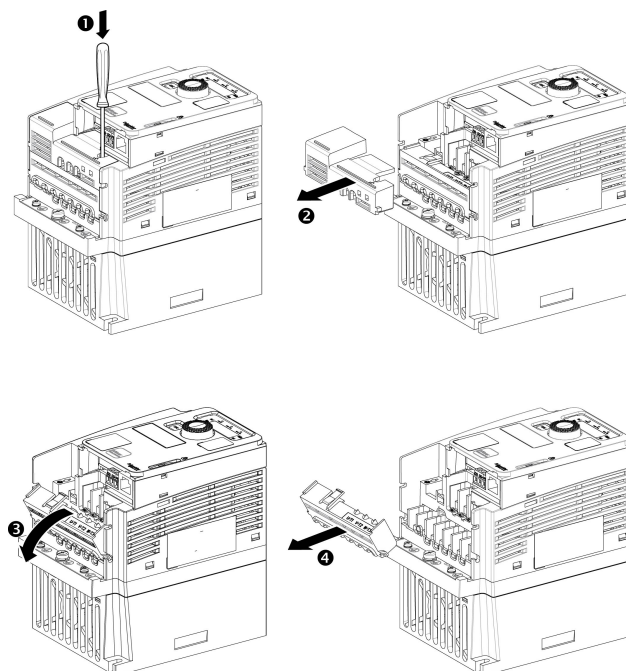

Apply the following instructions to access the power terminals on **frame sizes 2** drives:

Step	Action
1	Push the locking tab using a screwdriver.
2	Remove the wiring cover.
3	Incline the terminal cover
4	Remove the terminal cover

Power Terminals Arrangement For ATH230 Frame Size 2

Single-phase

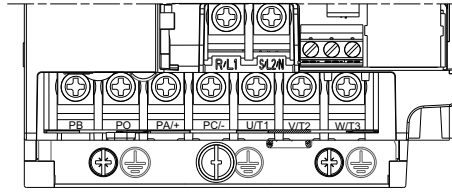

3-phase

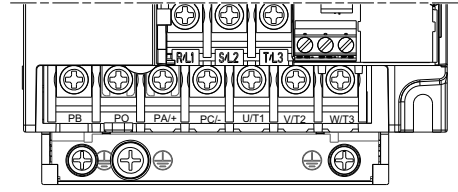

Access To The Terminals For ATH230 Frame Size 3

⚠️⚠️ DANGER

HAZARD OF ELECTRIC SHOCK, EXPLOSION OR ARC FLASH

Read and understand the instructions in **Product Related Information** chapter before performing any procedure in this chapter.

Failure to follow these instructions will result in death or serious injury.

⚠️⚠️ DANGER

HAZARD OF ELECTRIC SHOCK, EXPLOSION, OR ARC FLASH

After wiring the power terminals, refit properly the terminal cover and the wiring cover to meet the required degree of protection.

Failure to follow these instructions will result in death or serious injury.

Power supply terminals, motor terminals and braking resistor terminals are located on the bottom of the drive.

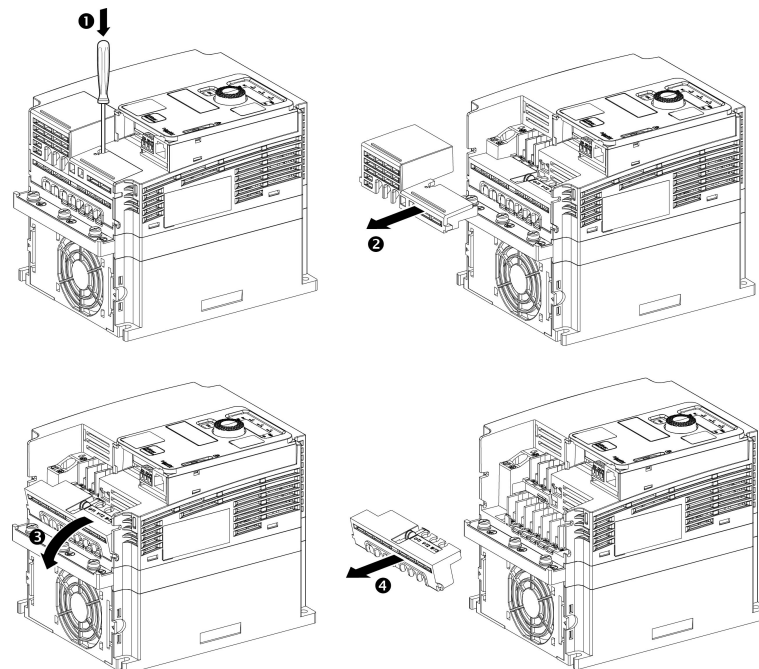

Apply the following instructions to access the power terminals on **frame sizes 3** drives:

Step	Action
1	Push the locking tab using a screwdriver.
2	Remove the wiring cover.
3	Incline the terminal cover
4	Remove the terminal cover

Power Terminals Arrangement For ATH230 Frame Size 3

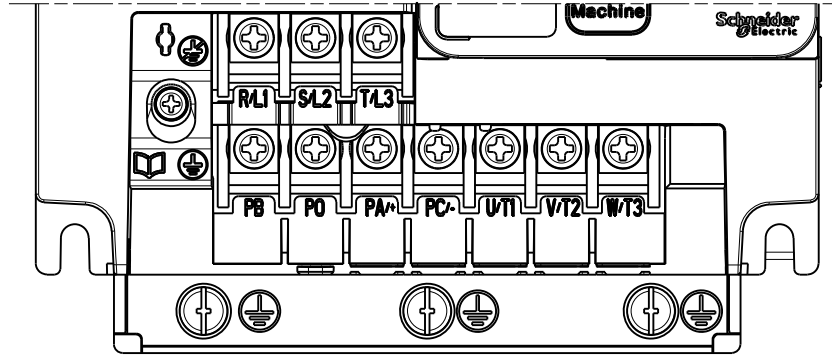

Access To The Terminals For ATH230 Frame Size 4

⚠️⚠️ DANGER

HAZARD OF ELECTRIC SHOCK, EXPLOSION OR ARC FLASH

Read and understand the instructions in **Product Related Information** chapter before performing any procedure in this chapter.

Failure to follow these instructions will result in death or serious injury.

⚠️⚠️ DANGER

HAZARD OF ELECTRIC SHOCK, EXPLOSION, OR ARC FLASH

After wiring the power terminals, refit properly the terminal cover and the wiring cover to meet the required degree of protection.

Failure to follow these instructions will result in death or serious injury.

Power supply terminals, motor terminals and braking resistor terminals are located on the bottom of the drive.

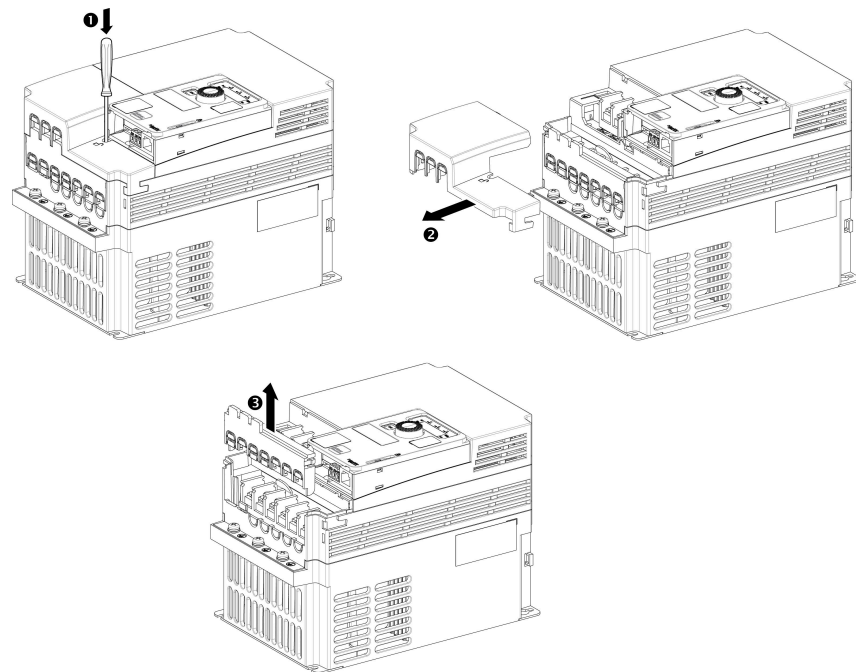

Apply the following instructions to access the power terminals on **frame sizes 4** drives:

Step	Action
1	Push the locking tab using a screwdriver.
2	Remove the wiring cover.
3	Remove the terminal cover

Power Terminals Arrangement For ATH230 Frame Size 4

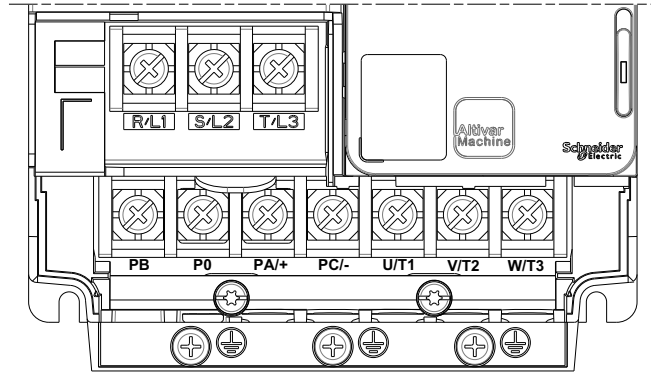

Access To The Terminals For ATH230 Frame Size 5

⚠️⚠️ DANGER

HAZARD OF ELECTRIC SHOCK, EXPLOSION OR ARC FLASH

Read and understand the instructions in **Product Related Information** chapter before performing any procedure in this chapter.

Failure to follow these instructions will result in death or serious injury.

⚠️⚠️ DANGER

HAZARD OF ELECTRIC SHOCK, EXPLOSION, OR ARC FLASH

After wiring the power terminals, refit properly the terminal cover and the wiring cover to meet the required degree of protection.

Failure to follow these instructions will result in death or serious injury.

Power supply terminals, motor terminals and braking resistor terminals are located on the bottom of the drive.

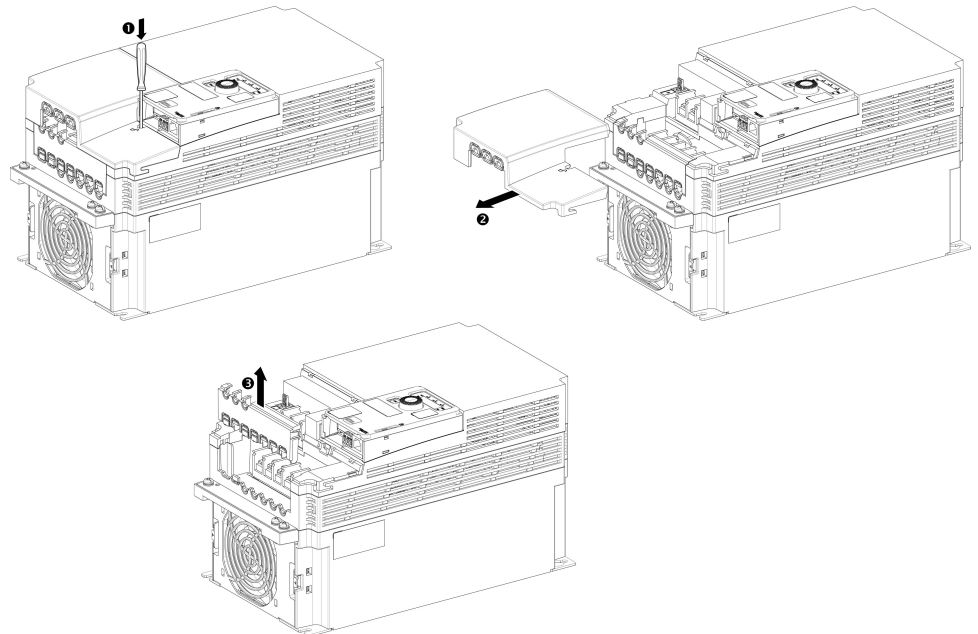

Apply the following instructions to access the power terminals on **frame sizes 5** drives:

Step	Action
1	Push the locking tab using a screwdriver.
2	Remove the wiring cover.
3	Remove the terminal cover

Power Terminals Arrangement For ATH230 Frame Size 5

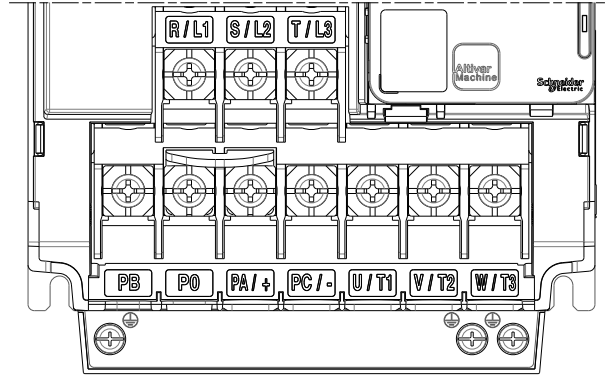

Access To The Terminals For ATH230 Frame Size 6

⚠️⚠️ DANGER

HAZARD OF ELECTRIC SHOCK, EXPLOSION OR ARC FLASH

Read and understand the instructions in **Product Related Information** chapter before performing any procedure in this chapter.

Failure to follow these instructions will result in death or serious injury.

⚠️⚠️ DANGER

HAZARD OF ELECTRIC SHOCK, EXPLOSION, OR ARC FLASH

After wiring the power terminals, refit properly the terminal cover and the wiring cover to meet the required degree of protection.

Failure to follow these instructions will result in death or serious injury.

Power supply terminals, motor terminals and braking resistor terminals are located on the bottom of the drive.

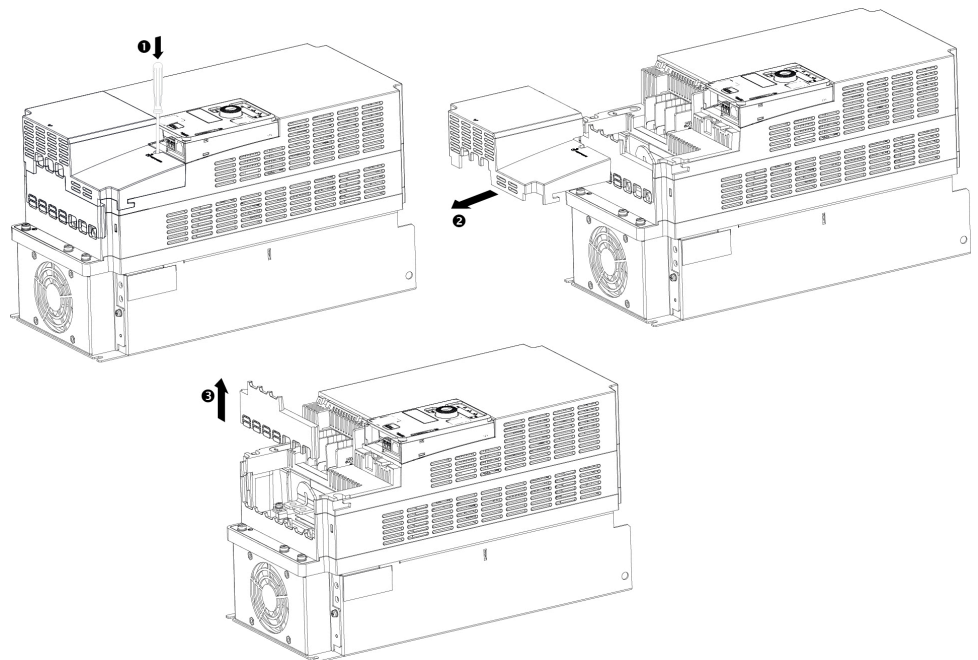

Apply the following instructions to access the power terminals on **frame sizes 6** drives:

Step	Action
1	Push the locking tab using a screwdriver.
2	Remove the wiring cover.
3	Remove the terminal cover

Power Terminals Arrangement For ATH230 Frame Size 6

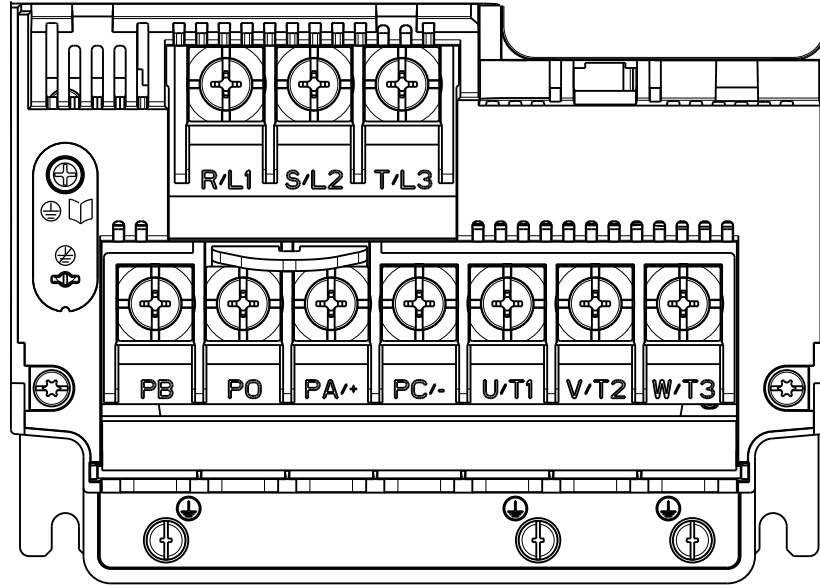

EMC plate assembly fitting

EMC Plate Assembly Fitting on ATH230 Frame Size 1

Attach the EMC plate using 2 x M5 High Strength screws (1)

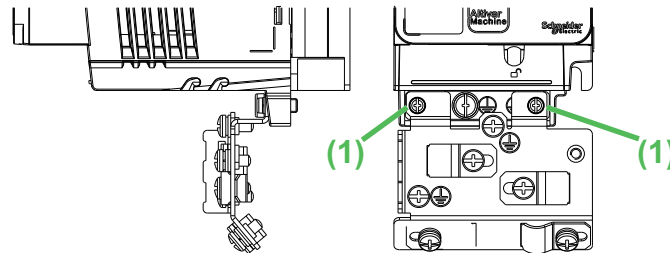

EMC Plate Assembly Fitting on ATH230 Frame Size 2

Attach the EMC plate using 2 x M5 High Strength screws (1)

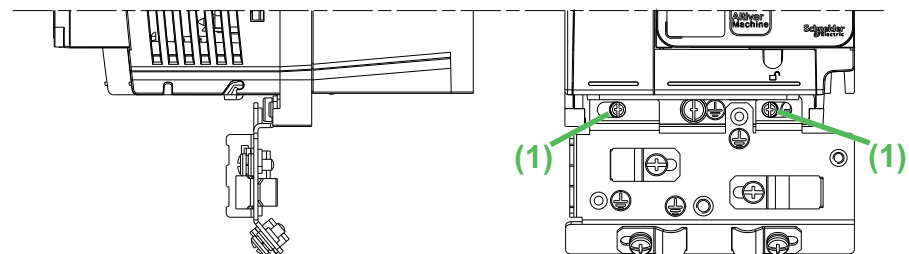

EMC Plate Assembly Fitting on ATH230 Frame Size 3

Attach the EMC plate using 2 x M5 High Strength screws (1)

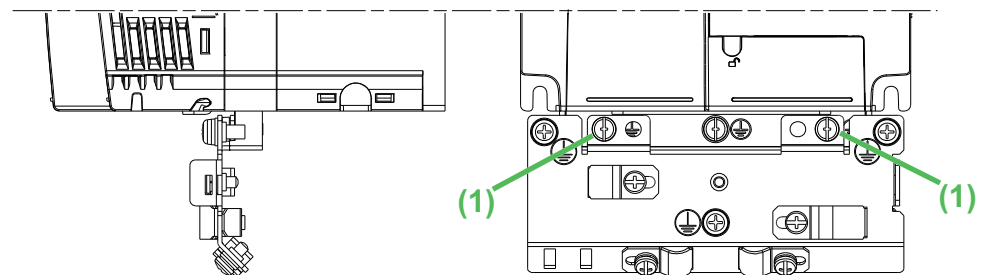

EMC Plate Assembly Fitting on ATH230 Frame Size 4

Attach the EMC plate using 3 x M5 High Strength screws (1)

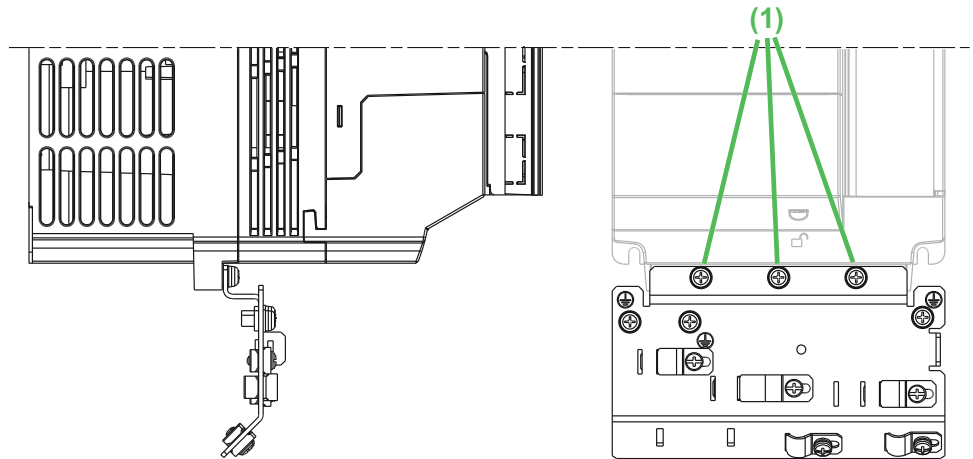

EMC Plate Assembly Fitting on ATH230 Frame Size 5

Attach the EMC plate using 2 x M5 High Strength screws (1)

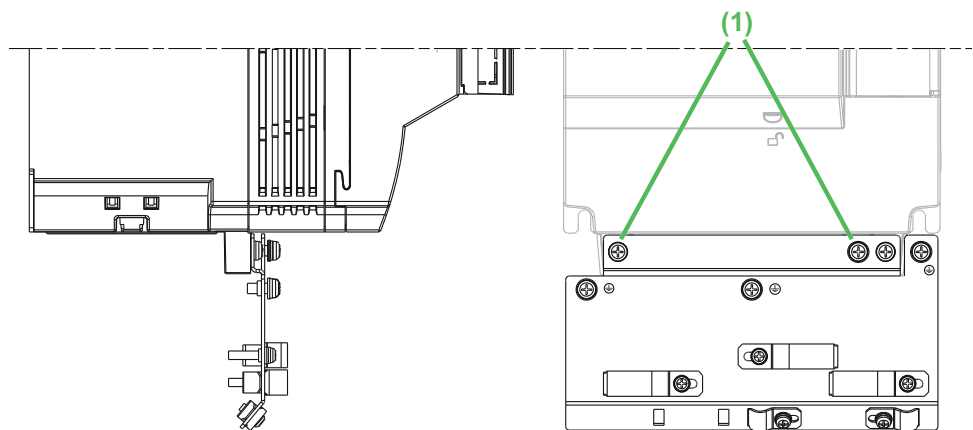

EMC Plate Assembly Fitting on ATH230 Frame Size 6

Attach the EMC plate using 2 x M5 High Strength screws (1)

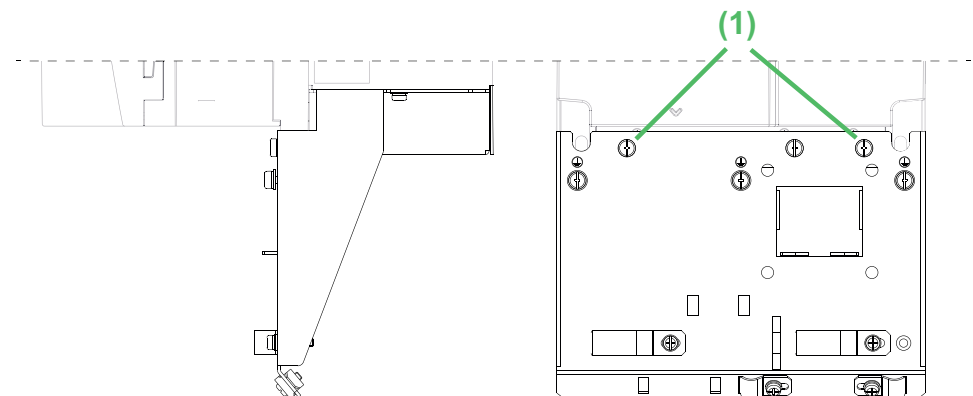

EMC Plates Cable Routing

Frame Size 1 to 4:

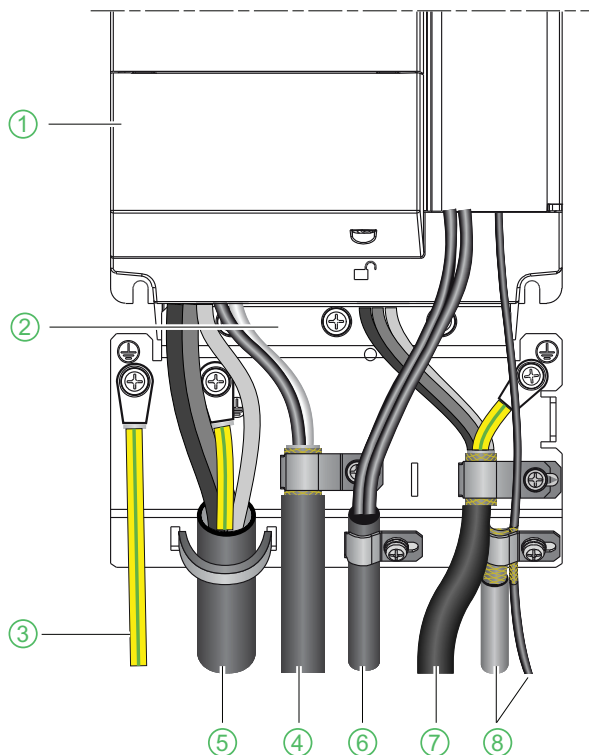

Frame Size 5:

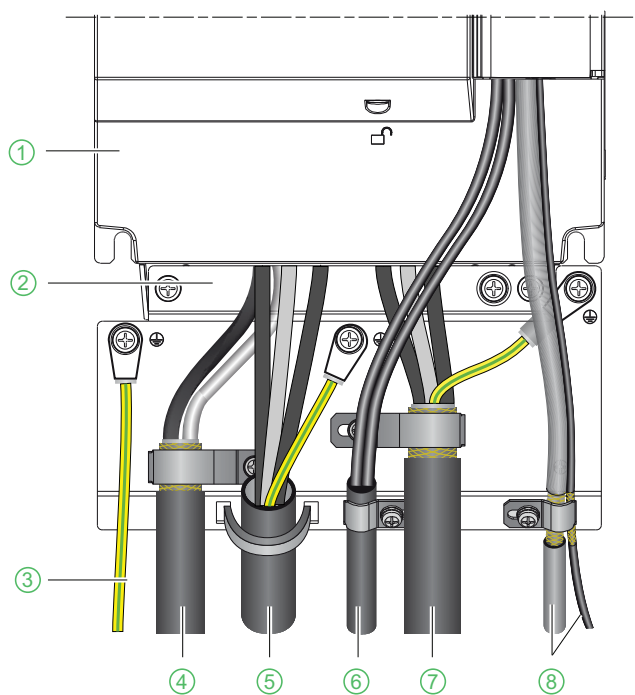

Frame Size 6:

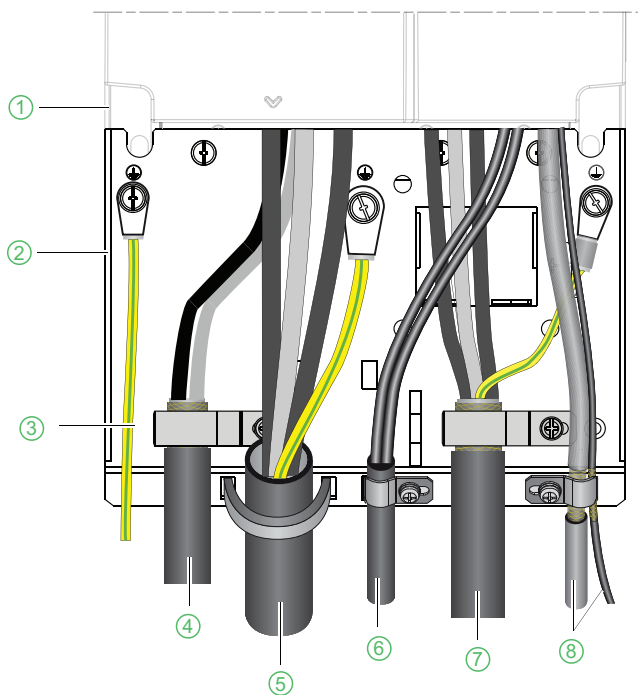

- ① ATH drive
- ② Sheet steel grounded EMC plate.
- ③ Protective ground connection.
- ④ Shielded cable for braking resistor connection (if used). The shielding must be continuous and intermediate terminals must be installed on EMC plate.
- ⑤ Non-shielded cable or wires for drive power supply
- ⑥ Non-shielded wires for relay contact output.
- ⑦ Shielded cable for motor connection, with shielding connected to ground at both ends. The shielding must be continuous and intermediate terminals must be installed on EMC plate.
- ⑧ Shielded cable for control-signal section and STO safety function input connection.

Electromagnetic Compatibility

Signal interference can cause unexpected responses of the device and of other equipment in the vicinity of the device.

⚠ WARNING
<p>SIGNAL AND EQUIPMENT INTERFERENCE</p> <ul style="list-style-type: none"> • Install the wiring in accordance with the EMC requirements described in this document. • Verify compliance with the EMC requirements described in this document. • Verify compliance with all EMC regulations and requirements applicable in the country in which the product is to be operated and with all EMC regulations and requirements applicable at the installation site. <p>Failure to follow these instructions can result in death, serious injury, or equipment damage.</p>

Limit Values

This product (*) meets the EMC requirements according to the standard IEC 61800-3 if the measures described in this manual are implemented during installation.

(*): Except ATH230•••M3 drives (for 3-phase 200...240 Vac supply mains) and ATH230•••S6 drives (for 3-phase 525...600 Vac supply mains). These drives do not include an EMC filter.

If the selected composition (product itself, mains filter, other accessories and measures) does not meet the requirements of category C1, the following information applies as it appears in IEC 61800-3:

⚠ WARNING
<p>RADIO INTERFERENCE</p> <p>In a domestic environment this product may cause radio interference in which case supplementary mitigation measures may be required.</p> <p>Failure to follow these instructions can result in death, serious injury, or equipment damage.</p>

EMC requirements for the control cabinet

EMC measures	Objective
Use mounting plates with good electrical conductivity, connect large surface areas of metal parts, remove paint from contact areas.	Good conductivity due to large surface contact.
Ground the control cabinet, the control cabinet door and the mounting plate with ground straps or ground wires. The conductor cross section must be at least 10 mm ² (AWG 8).	Reduces emissions.
Fit switching devices such as power contactors, relays or solenoid valves with interference suppression units or arc suppressors (for example, diodes, varistors, RC circuits).	Reduces mutual interference.
Install power components and control components separately.	

Shielded cables

EMC measures	Objective
Connect large surface areas of cable shields, use cable clamps and ground straps.	Reduces emissions.
Use cable clamps to connect a large surface area of the shields of all shielded cables to the mounting plate at the control cabinet entry.	
Ground shields of digital signal wires, page 92 at both ends by connecting them to a large surface area or via conductive connector housings	Reduces interference affecting the signal wires, reduces emissions
Ground the shields of analog signal wires directly at the device (signal input); insulate the shield at the other cable end or ground it via a capacitor (for example, 10 nF, 100 V or higher).	Reduces ground loops due to low-frequency interference.
Use only shielded motor cables with copper braid and a coverage of at least 85%, ground a large surface area of the shield at both ends.	Diverts interference currents in a controlled way, reduces emissions.

Cable Installation

EMC measures	Objective
Do not route fieldbus cables and signal wires in a single cable duct together with lines with DC and AC voltages of more than 60 V. (Fieldbus cables, signal lines and analog lines may be in the same cable duct) Recommendation: Use separate cable ducts at least 20 cm apart.	Reduces mutual interference.
Keep cables as short as possible. Do not install unnecessary cable loops, use short cables from the central grounding point in the control cabinet to the external ground connection.	Reduces capacitive and inductive interference.
Use equipotential bonding conductors in the following cases: wide-area installations, different voltage supplies and installation across several buildings.	Reduces current in the cable shield, reduces emissions.
Use fine stranded equipotential bonding conductors.	Diverts high-frequency interference currents
If motor and machine are not conductively connected, for example by an insulated flange or a connection without surface contact, you must ground the motor with a ground strap or a ground wire. The conductor cross section must be at least 10 mm ² (AWG 6).	Reduces emissions, increases immunity.
Use twisted pair for the DC supply. For digital and analog inputs use shielded twisted cables with a pitch of between 25...50 mm (1...2 in).	Reduces interference affecting the signal cables, reduces emissions.

Power Supply

EMC measures	Objective
Operate product on mains with grounded neutral point.	Enables effectiveness of mains filter.
Surge arrester if there is a risk of overvoltage.	Reduces the risk of damage caused by overvoltage.

Additional measures for EMC improvement

Depending on the application, the following measures can improve the EMC-dependent values:

EMC measures	Objective
Use mains chokes	Reduces mains harmonics, prolongs product service life.
Use external mains filters	Improves the EMC limit values.
Additional EMC measures, for example mounting in a closed control cabinet with 15 dB shielding attenuation of radiated interference	

NOTE: If using an additional input filter, it should be mounted side by side to the drive and connected directly to the supply mains via an unshielded cable.

Frame Size 6: Additional measures for EMC improvement for Motor terminals

For external ferrite EMI cable core application, requirements are as below:

- Only applied under 4kHz/C2/5m condition.
- Only use cables with insulator heat resistance of 90°C (194°F) min.
- Only use 16mm² (AWG 6) shielded cable.
- Recommend buying the ferrite core from supplier Laird with MPN 28B2000-100HST directly. For further information please contact SE.

Use 2pcs of cable tie to fix the ferrite core with EMC plate.

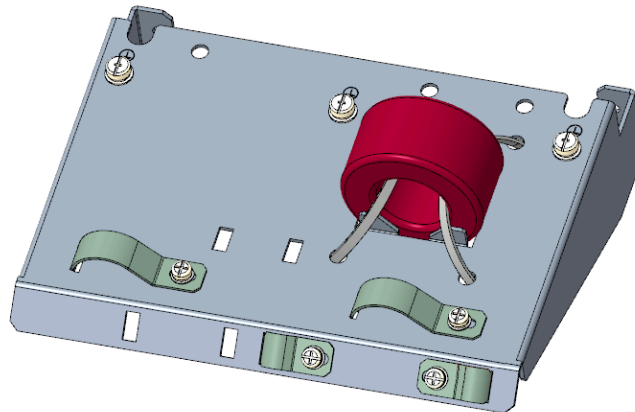

Cable tie requirements:

- Material: PA66 heat stabilized
- Operating Temperature: -25°C~+105°C
- Flame retardant rating: UL94 V-2
- Color: no limit

Control Terminals Electrical Data

Characteristics of Terminals

NOTE:

- For a description of the terminal arrangement, refer to Arrangement and Characteristics of Control Terminals and Communication And I/O Ports, page 136
- For factory setting I/O assignment, refer to the Programming manual, page 13.

Terminal	Description	I/O Type	Electrical characteristics
R1A	NO contact of relay R1	O	Output Relay 1 <ul style="list-style-type: none"> • Minimum switching capacity: 5 mA for 24 Vdc • Maximum switching current on resistive load: 3 A for 250 Vac (OVC II) and 30 Vdc • Maximum switching current on inductive load: 2 A for 250 Vac (OVC II) and 30 Vdc. Inductive load must be equipped with a voltage surge suppression device according to ac or dc operation with total energy dissipation greater than the inductive energy stored in the load. Refer to sections Output Relay with Inductive AC Loads , page 96 and Output Relay with Inductive DC Loads , page 97. • Refresh time: 2 ms • Service life: 100,000 operations at maximum switching current
R1B	NC contact of relay R1	O	
R1C	Common point contact of relay R1	O	
R2A R2C	NO contact of programmable relay R2	O	Output Relay 2 <ul style="list-style-type: none"> • Minimum switching capacity: 5 mA for 24 Vdc • Maximum switching current on resistive load: 5 A for 250 Vac (OVC II) and 30 Vdc. • Maximum switching current on inductive load: 2 A for 250 Vac (OVC II) and 30 Vdc. Inductive load must be equipped with a voltage surge suppression device according to ac or dc operation with total energy dissipation greater than the inductive energy stored in the load. Refer to sections Output Relay with Inductive AC Loads , page 96 and Output Relay with Inductive DC Loads , page 97. • Refresh time: 2 ms • Service life: <ul style="list-style-type: none"> ◦ 100,000 operations at maximum switching power ◦ 1,000,000 operations at 1 A
AI1	Voltage analog input	I	Analog input 0 + 10 Vdc <ul style="list-style-type: none"> • Impedance: 30 kΩ • Resolution: 10 bit converter • Accuracy: <ul style="list-style-type: none"> ◦ ±0.5 % at 25 °C (77 °F) ◦ ±0.7 % for a temperature variation of 60 °C (140 °F) • Linearity ±0.2 % (maximum ±0.5 %) of full scale • Sampling time: 2 ms
AI2	Voltage analog input	I	Bipolar analog input 0 ± 10 Vdc (maximum voltage ± 30 Vdc) <p>The + or – polarity of the voltage on AI2 affects the direction of the setpoint and therefore the direction of operation.</p> <ul style="list-style-type: none"> • Impedance: 30 kΩ • Resolution: 10 bits • Accuracy: <ul style="list-style-type: none"> ◦ ±0.5 % at 25 °C (77 °F) ◦ ±0.7 % for a temperature variation of 60 °C (140 °F) • Linearity ±0.2 % (maximum ±0.5 %) of full scale • Sampling time: 2 ms

Terminal	Description	I/O Type	Electrical characteristics
AI3	Current analog input	I	<p>Analog input 0-20 mA (or 4-20 mA, X-20 mA, 20-Y mA). X and Y can be programmed from 0 to 20 mA</p> <ul style="list-style-type: none"> • Impedance: 250 Ω • Resolution: 10 bits • Accuracy: <ul style="list-style-type: none"> ◦ $\pm 0.5\%$ at 25 °C (77 °F) ◦ $\pm 0.7\%$ for a temperature variation of 60 °C (140 °F) • Linearity $\pm 0.2\%$ (maximum $\pm 0.5\%$) of full scale • Sampling time: 2 ms
AQ1	Analog output	O	<p>AQ: Analog output software-configurable for voltage or current</p> <ul style="list-style-type: none"> • Voltage analog output 0...10 Vdc. Minimum load impedance 470 Ω, • Current analog output X-Y mA by programming X and Y from 0...20 mA, maximum load impedance 800 Ω • Sampling time: 2 ms • Resolution 10 bits • Accuracy: <ul style="list-style-type: none"> ◦ $\pm 1\%$ at 25 °C ± 10 °C (77 °F ± 18 °F) ◦ $\pm 2\%$ for a temperature variation of 60 °C (140 °F) • Linearity $\pm 0.3\%$
10V	Power supply for reference potentiometer	O	<p>Internal supply for the analog inputs</p> <ul style="list-style-type: none"> • + 10 Vdc • Tolerance: 0...10 % • Current: maximum 10 mA
COM	Analog I/O common	I/O	0 V
+24	Digital input power supply	I/O	<ul style="list-style-type: none"> • +24 Vdc input supply • Tolerance: -15...+20 % • Current: 100 mA • Terminal protected against overload and short-circuit
P24	Input for an external 24 Vdc supply / Output power supply for digital inputs and STO	I/O	<ul style="list-style-type: none"> • +24 Vdc • Tolerance: -15...+20 % • Current: maximum 1.1 A • Terminal protected against overload and short-circuit
STO	STO (Safe Torque Off) input	I	<ul style="list-style-type: none"> • Input: +24 Vdc • Impedance: 1.5 kΩ • Refer to the Wiring Diagrams section, page 92 and the ATH200 Safety Functions Manual, page 13.
DI4 DI3 DI2 DI1	Digital inputs	I	<p>4 programmable digital inputs configurable as sink or source using SW1 switch, page 136</p> <ul style="list-style-type: none"> • + 24 Vdc power supply (maximum 30 Vdc) • State 0 if < 5 Vdc, state 1 if > 11 Vdc (in source mode) • State 0 if > 16 Vdc, state 1 if < 10 Vdc (in sink mode) • Response time 8 ms at Stop
DI5	Digital inputs	I	<ul style="list-style-type: none"> • If programmed as digital inputs, same characteristics as DI1 to DI4. • DI5 can be programmed as pulse input 20 kpps (pulse per second). <p>NOTE: When the pulse input is supplied by an open collector output (PNP or NPN), it is mandatory to wire an external resistor (pull-up for NPN output and pull-down for PNP) in order to obtain full speed performance. Ohmic value and rated power must be adjusted to fit with output transistor capability / supply voltage. Any value below 10kΩ should be sufficient, however in case of problems to reach full speed, consider lowering below 2.2kΩ. It is not necessary for push-pull outputs.</p>
DI6	Digital inputs	I	<ul style="list-style-type: none"> • If programmed as digital inputs, same characteristics as DI1 to DI4. • DI6 can be used as PTC (Positive Temperature Coefficient) using SW2 switch, page 136. • Trip threshold: 3 kΩ, reset threshold: 1.8 kΩ • Short-circuit detection threshold < 50 Ω

Terminal	Description	I/O Type	Electrical characteristics
DQ+ DQ-	Digital output	O	Open collector output configurable as sink or source using SW1 switch <ul style="list-style-type: none">• Refresh time: 2 ms• Maximum voltage: 30 Vdc• Maximum current: 100 mA
PE	Protective earth	–	Protective earth for fast communication. Wiring is detailed in the Control Block Wiring section, page 138

Arrangement and Characteristics of Control Block Terminals and Communication and I/O Ports

Wiring Characteristics

⚡ ⚠ DANGER

HAZARD OF FIRE OR ELECTRIC SHOCK

- Wire cross sections and tightening torques must comply with the specifications provided in this document.
- If you use flexible multi-wire cables for a connection with a voltage higher than 25 Vac, you must use ring type cable lugs or wire ferrules, depending on the wire gauge and the specified stripping length of the cable.

Failure to follow these instructions will result in death or serious injury.

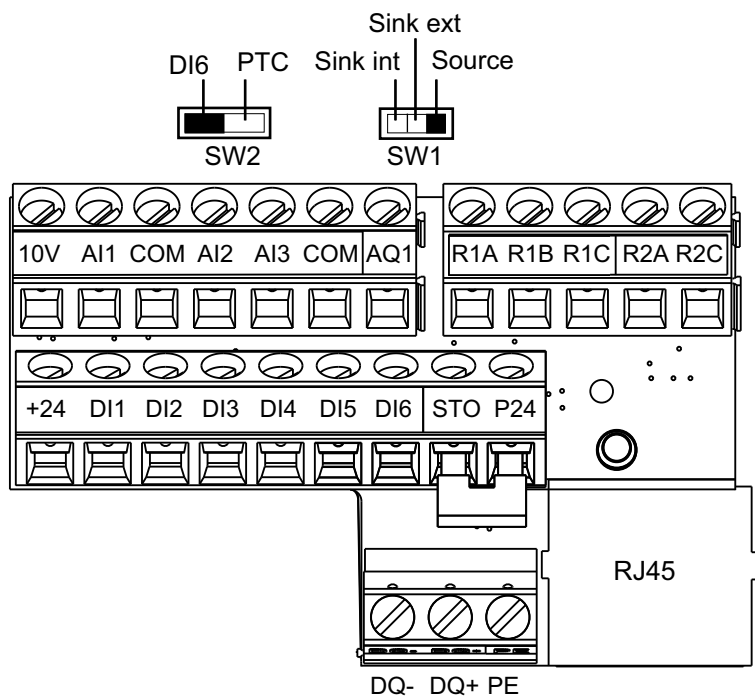

Wire cross sections and tightening torques

Control Terminals	Relay Output Wire Cross Section		Other Wire Cross Section		Tightening Torque
	Minimum (1)	Maximum	Minimum (1)	Maximum	
	mm ² (AWG)	mm ² (AWG)	mm ² (AWG)	mm ² (AWG)	
All terminals	0.75 (18)	1.5 (16)	0.5 (20)	1.5 (16)	0.5 (4.4)

(1) The value corresponds to the minimum permissible cross section of the terminal.

NOTE: Control Terminal Electrical data., page 133

RJ45 Communication port

It is used to connect a:

- PC using SoMove software
- Remote graphic display terminal, using a Modbus serial line
- Modbus or BACnet network
- Configuration loader tool...

NOTE: Check that the RJ45 cable is not damaged prior to connect it to the product otherwise the power supply of the control could be lost.

Wiring The Control Part

PELV Requirements of Connected Devices

DANGER

HAZARD OF ELECTRIC SHOCK, EXPLOSION OR ARC FLASH

- Verify that the temperature sensors in the motor meet the PELV requirements.
- Verify that the motor encoder meets the PELV requirements.
- Verify that any other equipment connected via signal cables meets the PELV requirements.

Failure to follow these instructions will result in death or serious injury.

WARNING

UNANTICIPATED EQUIPMENT OPERATION

- Use shielded cables for all digital and analog I/O signals and communication signals.
- Ground cable shields at a single point.
- Route communication cables and I/O cables separately from power cables

Failure to follow these instructions can result in death, serious injury, or equipment damage.

WARNING

UNANTICIPATED EQUIPMENT OPERATION

Verify that the digital and analog inputs and outputs are wired with the shielded, twisted-pair cables specified in the present manual.

Failure to follow these instructions can result in death, serious injury, or equipment damage.

- Keep the control circuits away from the power cables. For digital and analog inputs/outputs, use shielded twisted cables with a pitch of 25...50 mm (1 in. and 2 in.)
- It is advisable to use cable ends, available on www.se.com.

NOTICE

INCORRECT VOLTAGE

Supply the digital inputs with 24 Vdc only.

Failure to follow these instructions can result in equipment damage.

Optional Module Installation and Wiring

NOTE:

- For approved fieldbus module list, refer to the catalog.
- For fieldbus modules information, refer to the instruction sheet S1A45591 available on www.se.com.

Access to the Terminals

⚠️ DANGER

HAZARD OF ELECTRIC SHOCK, EXPLOSION OR ARC FLASH

Read and understand the instructions in **Product Related Information** chapter before performing any procedure in this chapter.

Failure to follow these instructions will result in death or serious injury.

Open the cover as shown in the examples below to access the terminals. All screws are M3 slotted type, 3.8 mm (0.15 in.) diameter.

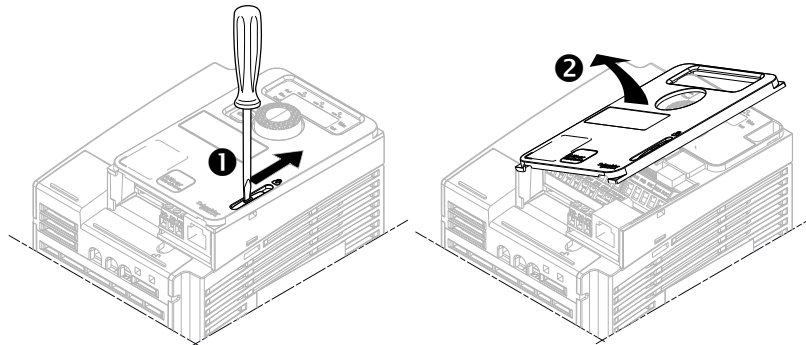

Control block can be removed to facilitate the wiring.

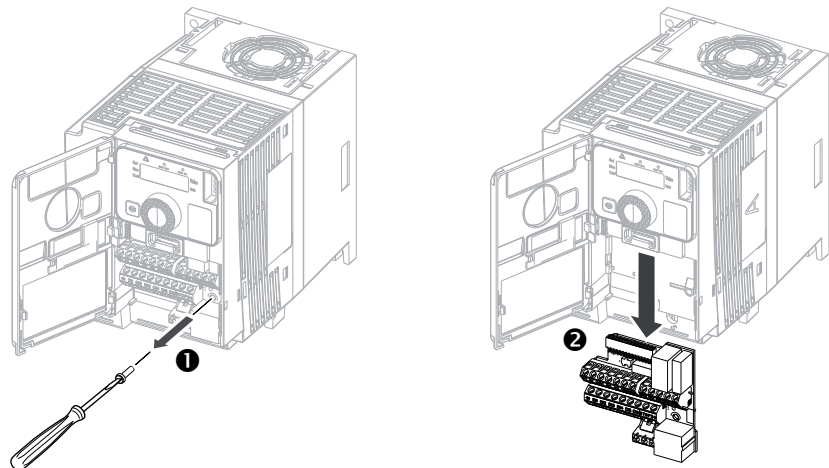

Control Block Wiring

Apply the following instructions to wire the control block terminals:

Step	Action
1	Wire the P24, the STO, the digital inputs (DI1...DI6), the +24, DQ-, DQ+ and PE terminals
2	Wire the 10V, the analog inputs (AI1...AI3), the COM, The digital input AQ1 and the COM terminals
3	Wire the Relay outputs
4	Wire the PE terminal as shown below - example of frame size 3

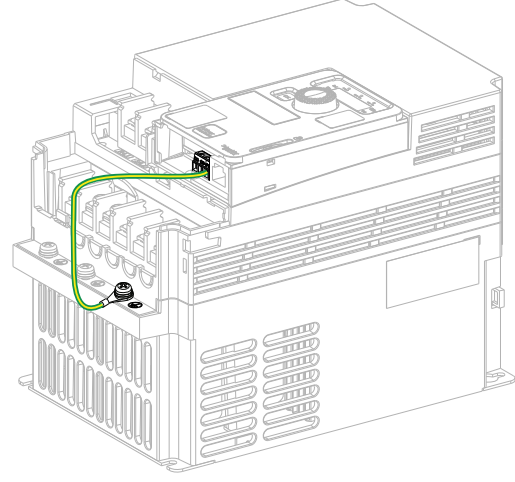

Checking Installation

Before Switching On

The safety function STO (Safe Torque Off) does not remove power from the DC bus. The safety function STO only removes power to the motor. The DC bus voltage and the mains voltage to the drive are still present.

DANGER

HAZARD OF ELECTRIC SHOCK

- Do not use the safety function STO for any other purposes than its intended function.
- Use an appropriate switch, that is not part of the circuit of the safety function STO, to disconnect the product from the mains power.

Failure to follow these instructions will result in death or serious injury.

Unsuitable settings or unsuitable data or unsuitable wiring may trigger unintended movements, trigger signals, damage parts and disable monitoring functions.

WARNING

UNANTICIPATED EQUIPMENT OPERATION

- Only start the system if there are no persons or obstructions in the zone of operation.
- Verify that a functioning emergency stop push-button is within reach of all persons involved in the operation.
- Do not operate the product with unknown settings or data.
- Verify that the wiring is appropriate for the settings.
- Never modify a parameter unless you fully understand the parameter and all effects of the modification.
- When commissioning, carefully run tests for all operating states, operating conditions and potential error situations.
- Anticipate movements in unintended directions or oscillation of the motor.

Failure to follow these instructions can result in death, serious injury, or equipment damage.

If the power stage is disabled unintentionally, for example as a result of power outage, errors or functions, there is a possibility that the motor is no longer decelerated in a controlled way.

WARNING

UNANTICIPATED EQUIPMENT OPERATION

Verify that movements without braking effect does not result in unsafe conditions.

Failure to follow these instructions can result in death, serious injury, or equipment damage.

Mechanical Installation

Verify the mechanical installation of the entire drive system:

Step	Action	✓
1	Does the device is mounted in a vertical position at $\pm 10^\circ$?	
2	Does the installation meet the specified distance requirements? NOTE: Adhere to the minimum installation distances for required cooling.	
3	Does the device is mounted on a flat, solid and vibration-free surface?	
4	Does the device is installed indoors, away from heat sources and away from flammable materials.? NOTE: Avoid environmental effects like high temperatures and high humidity as well as dust, dirt and conductive gases.	
5	Does the device is attached to the mounting surface using screws and washers according to the tables shown within the Mounting Holes and Screws, page 65?	
6	Does the fastening screws are tightened to the torque specified in the Mounting Holes and Screws, page 65.	

Electrical installation

Verify the electrical connections and the cabling:

Step	Action	✓
1	Did you connect all protective ground conductors?	
2	Do all fuses and circuit breaker have the correct rating; are the fuses of the specified type? The values and products for IEC compliance are specified in the present manual. The values and products for UL/CSA compliance are specified in the ATH200 Getting Started Annex, page 13	
3	Did you connect or insulate all wires at the cable ends?	
4	Did you properly connect and install all cables and connectors?	
5	Did you properly connect the signal wires?	
6	Are the required shield connections EMC-compliant?	
7	Did you take all measures for EMC compliance?	

Covers And Seals

Verify that all devices, doors and covers of cabinet are properly installed to meet the required degree of protection.

Maintenance

What's in This Part

Scheduled Servicing.....	144
Long-term Storage	146
Decommissioning.....	147
Additional Support.....	148

Scheduled Servicing

Servicing

DANGER

HAZARD OF ELECTRIC SHOCK, EXPLOSION OR ARC FLASH

Read and understand the instructions in **Product Related Information** chapter before performing any procedure in this chapter.

Failure to follow these instructions will result in death or serious injury.

The temperature of the products described in this manual may exceed 80 °C (176 °F) during operation.

WARNING

HOT SURFACES

- Ensure that any contact with hot surfaces is avoided.
- Do not allow flammable or heat-sensitive parts in the immediate vicinity of hot surfaces.
- Verify that the product has sufficiently cooled down before handling it.
- Verify that the heat dissipation is sufficient by performing a test run under maximum load conditions.

Failure to follow these instructions can result in death, serious injury, or equipment damage.

WARNING

INSUFFICIENT MAINTENANCE

Verify that the maintenance activities described below are performed at the specified intervals.

Failure to follow these instructions can result in death, serious injury, or equipment damage.

Adherence to the environmental conditions must be ensured during operation of the device. In addition, during maintenance, verify and, if appropriate, correct all factors that may have an impact on the environmental conditions.

Maintenance Activities

	Part concerned	Activity	Interval (1)
Overall condition	All parts such as housing, HMI, control block, connections, etc.	Perform a visual inspection	At least every year
Corrosion	Terminals, connectors, screws, EMC plate	Inspect and clean if required	
Dust	Terminals, fans, cabinet air inlets and air outlets, air filters of cabinet	Inspect and clean if required	
Cooling	Fan	Verify the fan operation	
Fastening	All screws for electrical and mechanical connections	Verify tightening torques	
(1)	Maximum maintenance intervals from the date of commissioning. Reduce the intervals between maintenance to adapt maintenance to the environmental conditions, the operating conditions of the drive, and to any other factor that may influence the operation and/ or maintenance requirements of the drive.		

NOTE: The fan operation depends on the drive thermal state. The drive may be running and the fan not.

Fans may continue to run for a certain period of time even after power to the product has been disconnected.

⚠ CAUTION
RUNNING FANS
Verify that fans have come to a complete standstill before handling them.
Failure to follow these instructions can result in injury or equipment damage.

Diagnostic And Troubleshooting

Refer to the Programming manual, page 13.

Spares and repairs

Serviceable products:

Please refer to your Customer Care Center on www.se.com/CCC.

Long-term Storage

Capacitor Reforming

If the drive was not connected to mains for an extended period of time, the capacitors must be restored to their full performance before the motor is started.

NOTICE

REDUCED CAPACITOR PERFORMANCE

- Apply mains voltage to the drive for one hour before starting the motor if the drive has not been connected to mains for the specified periods of time.(1)
- Verify that no Run command can be applied before the period of one hour has elapsed.
- Verify the date of manufacture if the drive is commissioned for the first time and run the specified procedure if the date of manufacture is more than 12 months in the past.

Failure to follow these instructions can result in equipment damage.

(1) Period of time:

- 12 months at a maximum storage temperature of +50°C (+122°F)
- 24 months at a maximum storage temperature of +45°C (+113°F)
- 36 months at a maximum storage temperature of +40°C (+104°F)

If the specified procedure cannot be performed without a Run command because of internal mains contactor control, perform this procedure with the power stage enabled, but the motor being at a standstill so that there is no appreciable mains current in the capacitors.

Decommissioning

Uninstall the Product

Observe the following procedure when uninstalling the product.

- Switch off all supply voltage. Verify that no voltages are present - refer to the *Verifying the Absence of Voltage*, page 16.
- Remove all connection cables.
- Uninstall the product.

End of Life

The components of the product consist of different materials which can be recycled and which must be disposed of separately.

- Dispose of the packaging in compliance with all applicable regulations.
- Dispose of the product in compliance with all applicable regulations.

Refer to the *Environmental Data Program* for information and documents on environmental protection such as EoLI (End of Life instruction).

Additional Support

Customer Care Center

For additional support, you can contact our Customer Care Center on:

www.se.com/CCC.

Glossary

A

Abbreviations:

Req. = Required

Opt. = Optional

AC:

Alternating Current

D

DC:

Direct Current

E

ELV:

Extra-Low Voltage. For more information: IEC 60449

Error :

Discrepancy between a detected (computed, measured, or signaled) value or condition and the specified or theoretically correct value or condition.

F

Factory setting:

Machine status in factory settings when the product was shipped.

Fault Reset:

A function used to restore the drive to an operational state after a detected error is cleared by removing the cause of the error so that the error is no longer active.

Fault:

Fault is an operating state. If the monitoring functions detect an error, a transition to this operating state is triggered, depending on the error class. A "Fault reset" is required to exit this operating state after the cause of the detected error has been removed.

G

GP:

General-Purpose

L

L/R:

Time constant equal to the quotient of inductance value (L) over the resistance value (R).

N

NC contact:

Normally Closed contact

NO contact:

Normally Open contact

O

OEM:

Original Equipment Manufacturer

OVCII:

Overvoltage Category II, according IEC 61800-5-1

P

PA/+:

DC bus terminal

PC/-:

DC bus terminal

PELV:

Protective Extra Low Voltage, low voltage with isolation. For more information: IEC 60364-4-41.

PLC:

Programmable logic controller.

Power stage:

The power stage controls the motor. The power stage generates current for controlling the motor.

PTC:

Positive Temperature Coefficient. PTC thermistor probes integrated in the motor or application to measure its temperature

R

REACH:

Registration, Evaluation, Authorisation and restriction of Chemicals regulation

RoHS:

Restriction of Hazardous Substances

S

SCPD:

Short-Circuit Protective Device

SF: Switch Frequency

STO:

Safe Torque Off: No power that could cause torque or force is supplied to the motor

T

TVS Diode:

Transient Voltage Suppression Diode

V

VHP:

Very High Horse Power (> 800 kW)

VSD:

Variable Speed Drive

W

Warning:

If the term is used outside the context of safety instructions, a warning alerts to a potential error that was detected by a monitoring function. A warning does not cause a transition of the operating state.

Schneider Electric
35 rue Joseph Monier
92500 Rueil Malmaison
France

www.se.com

As standards, specifications, and design change from time to time, please ask for confirmation of the information given in this publication.

© 2025 – 2025 Schneider Electric. All rights reserved.

JPS43203.01 — 11/2025