

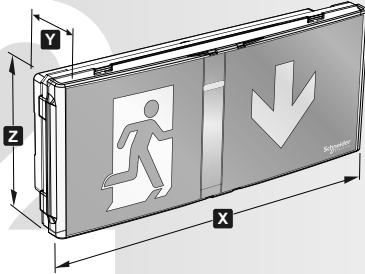

OVA53158

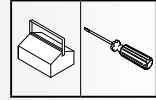

X	Y	Z	mm.
304	66	127	

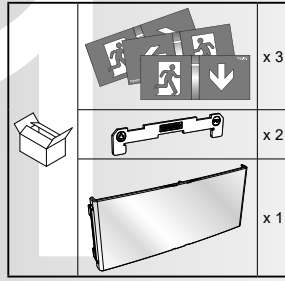
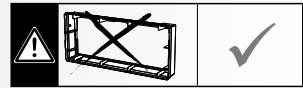
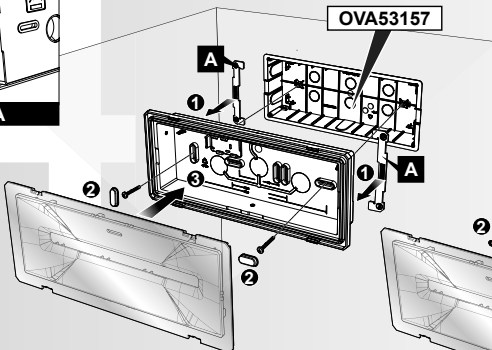
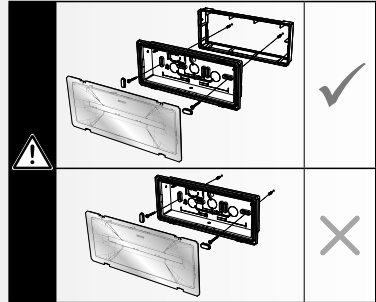
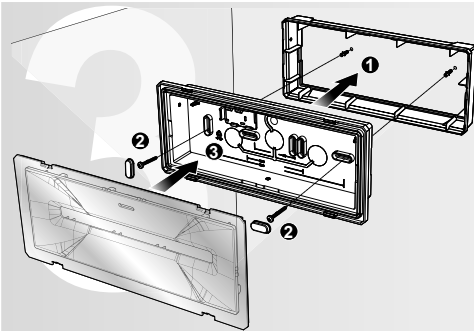

OVA59823

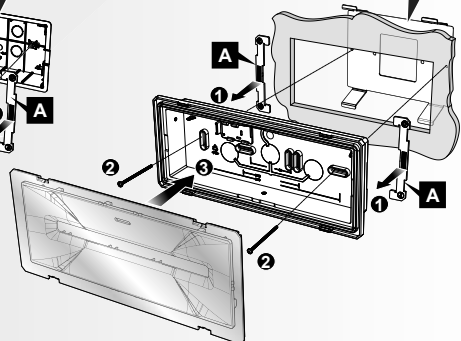

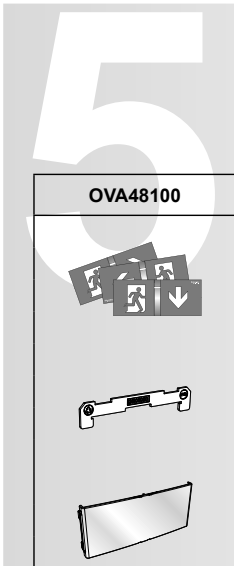
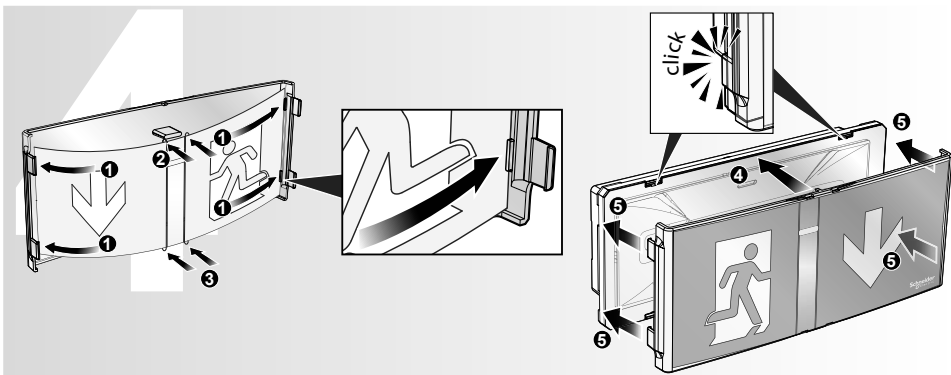

OVA48100	OVA48306	OVA48500	OVA48511
OVA48101	OVA48307	OVA48501	OVA48512
OVA48102	OVA48308	OVA48502	OVA48513
OVA48103	OVA48309	OVA48503	OVA48514
OVA48104	OVA48310	OVA48504	OVA48515
OVA48300	OVA48311	OVA48505	OVA48516
OVA48301	OVA48312	OVA48506	OVA48517
OVA48302	OVA48313	OVA48507	OVA48518
OVA48303	OVA48314	OVA48508	
OVA48304	OVA48315	OVA48509	
OVA48305	OVA48316	OVA48510	

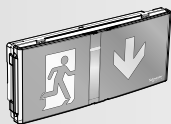

SMALTIMENTO

Il cassonetto barrato riportato sull'apparecchio specifica che il prodotto alla fine della propria vita utile deve essere consegnato ai centri di raccolta autorizzati o in alternativa riconsegnato al distributore/rivenditore all'atto dell'acquisto di uno nuovo (i prodotti con dimensioni inferiori a 25cm possono essere riconsegnati gratuitamente senza l'acquisto di uno nuovo presso i rivenditori con superficie di vendita di almeno 400m2). L'adeguata raccolta differenziata e il riciclaggio dell'apparecchio dismesso durante la fase di smaltimento favoriscono la conservazione delle risorse naturali e assicurano che venga riciclato in maniera tale da ridurre i possibili effetti negativi sulla salute e sull'ambiente. Per maggiori informazioni sui centri di raccolta, modalità e sui termini della Legge in vigore, rivolgersi all'ufficio competente del proprio ente locale.

DISPOSAL

The crossed out wheeled bin symbol on the product indicates that at the end of its life the product shall be returned to authorized waste collection centers or to whom has the right to manage it. The proper separate collection and recycling of waste equipment at the time of disposal will help to protect natural resources and ensure that it is recycled in a manner that reduces possible negative effects on human health and the environment. For more information regarding waste collection centers, modalities and terms of law in force, please contact your local waste disposal authority.