

REMOTE POWER PANEL - SPECIFICATIONS		
	250A (80% or 100% rated)	400A (80% or 100% rated)
1. AC Input		
1.1 Nominal Voltage (V)	240/480	240 or 480
1.2 Nominal input current	1x250A 100% / 1x250A 80% / 2x250A 100% / 2x250A 80%	1x400 A 100% / 1x400 A 80% / 2x400 A 80%
1.2 Input frequency (Hz)	60	60
1.3 Max short circuit withstand level (kA)	65kA at 240V and 35kA at 480V (Refer to series combination rating table)	
2. AC Output		
2.1 Nominal Voltage (V)	240/480	240/480
2.2 Nominal output current (A).	1x250A / 2x250A max	1x400A / 2x400A max
2.3 Output frequency (Hz)	60	60
2.4 Branch current protection (A)	10-100	10-100
2.6 Distribution breaker size (A)	Refer to sheet 6	Refer to sheet 6
2.7 Rated conditional short-circuit	Refer to sheet 6	Refer to sheet 6
3. Environment		
3.1 Operating temperature	-10°C to 40°C (14°F to 104°F)	-10°C to 40°C (14°F to 104°F)
3.2 Storage temperature	-25°C to 55°C (-13°F to 131°F)	-25°C to 55°C (-13°F to 131°F)
3.3 The assembly must be protected from water and conductive contaminants		
4. Enclosure		
4.1 The assembly material is steel with surface coating		
4.2 The assembly is made for indoor floor installation		
5. Connections		
5.1 Incoming and outgoing cables to be connected to terminals in component section		
5.2 Input cable entry is through top or bottom of the unit		
5.3 Output cable entry is through the top or bottom of the unit		

SERIES COMBINATION RATINGS						
NQ Series connected circuit breaker ratings (RMS symmetrical)						
Maximum system voltage AC [1]	Maximum short circuit current rating [2]	Square D brand integral or remote main Circuit Breakers	Square D brand branch Circuit Breaker catalog designation and allowable Ampere ranges			
			Type	1 Pole	2 Pole	3 Pole
120/240 1P/3W 208Y/120 3P/4W 240/120 3P/4W	65,000	JG, LG	QO (B)	15-70A	15-100A	-
		JG	QO (B)	-	-	15-100A
		LG	QO (B) VH	-	-	15-100A
NF Series connected circuit breaker ratings (RMS symmetrical)						
Maximum system voltage AC	Maximum short circuit current rating [2]	Square D brand integral or remote main Circuit Breakers	Square D brand branch Circuit Breaker catalog designation and allowable Ampere ranges			
			Type	1 Pole	2 Pole	3 Pole
277	480Y/277	JG, LG	EDB	15-70A	15-100A	15-100A

Foot Notes:

- Series ratings listed at higher system voltages apply to lower system voltages (example: 240 3P/3W covers 208Y/120 3P/4W).
- Short circuit tests are conducted at 100-105% of the maximum rated voltage of the panelboard.

THIS DRAWING AND SPECIFICATIONS HEREIN ARE THE PROPERTY OF SCHNEIDER ELECTRIC AND SHALL NOT BE COPIED, REPRODUCED OR USED IN WHOLE OR IN PART, AS THE BASIS FOR THE MANUFACTURE OR SALE OF ITEMS WITHOUT WRITTEN PERMISSION FROM SCHNEIDER ELECTRIC. THIS DRAWING IS BASED UPON LATEST AVAILABLE INFORMATION AND IS SUBJECT TO CHANGE WITHOUT NOTICE.



TITLE:		DWG NO:		REV.
REMOTE POWER PANEL Input: 3PH, 240V/480V Output: 3PH, 240V/480V SPECIFICATION		GRPP84		1
PROJECT: SUBMITTAL DRAWING		DRAWN BY:	JAYAPRAKASH	03-JUL-20
SHEET 1 OF 9		ENGINEER:	Gerardo Esquivel	03-JUL-20
APPROVED BY:		Gerardo Esquivel	03-JUL-20	N.A

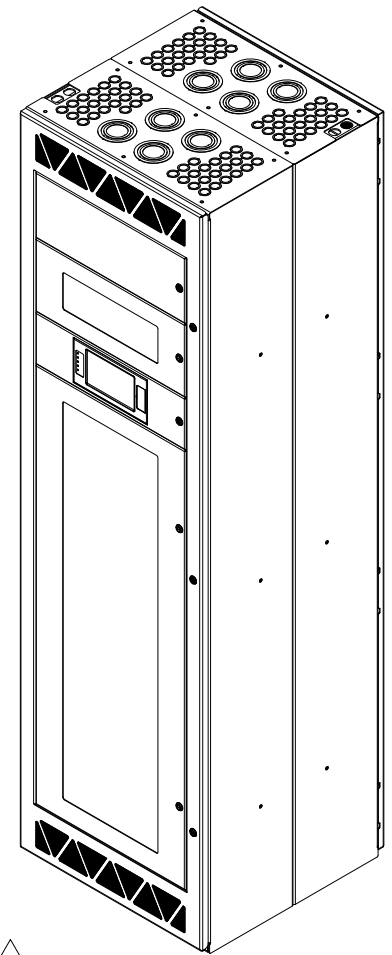
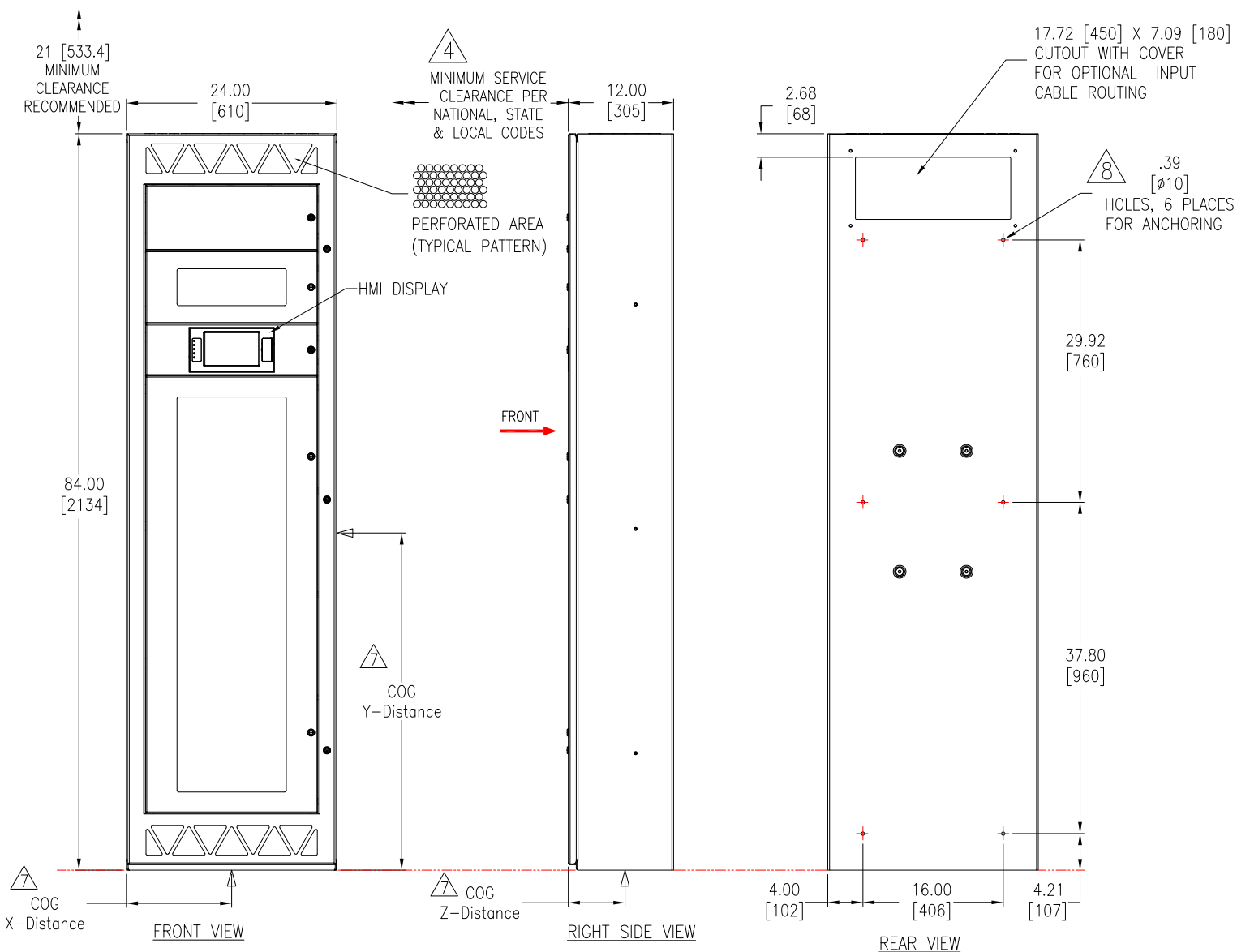

ISOMETRIC VIEW – BACK TO BACK ANCHORING

TABLE-1

COLOR, WEIGHT AND CENTER OF GRAVITY

SKU Number	Color	*Weight lb [kg]	Center of Gravity in Inches [mm]		
			X-Distance	Y-Distance	Z-Distance
GRPPNQ84	RAL9003 WHITE	441-551 [200-250]	11.96 [304]	42.46 [1078.5]	6.76 [171.7]
GRPPIP2X84	RAL9003 WHITE				
GRPPNF84	RAL9003 WHITE				

*FINAL WEIGHT DEPENDS ON SELECTED OPTOPNS

NOTES:

- INSTALLATION SHALL COMPLY WITH ALL APPLICABLE NATIONAL, STATE AND LOCAL CODES.
- REFER TO PRODUCT DOCUMENTATION FOR ADDITIONAL DETAILS PRIOR TO INSTALLATION AND SITE PREPARATION WORK.
- ALL DIMENSIONS ARE IN INCHES [MILLIMETERS].
- FRONT ACCESS REQUIRED FOR SERVICE. MINIMUM REQUIRED FRONT CLEARANCE IS 36.0 [914].
- CABLE ENTRY IS THROUGH TOP OR BOTTOM OF UNIT.
- REFER TO TABLE-1 FOR WEIGHT, COLOR AND CENTER OF GRAVITY OF THE UNIT.
- THIS INFORMATION PROVIDES APPROXIMATE CENTER OF GRAVITY CALCULATION.
- ANCHOR THE CABINET TO THE WALL, A RACK, OR TO THE RPP CABINET BEHIND IT WITH THE PROVIDED 3/8 INCH BOLTS.
- POWER CABLES SHALL BE IN SEPARATE CONDUITS FROM CONTROL AND COMMUNICATION CABLES.

THIS DRAWING AND SPECIFICATIONS HEREIN ARE THE PROPERTY OF SCHNEIDER ELECTRIC AND SHALL NOT BE COPIED, REPRODUCED OR USED IN WHOLE OR IN PART, AS THE BASIS FOR THE MANUFACTURE OR SALE OF ITEMS WITHOUT WRITTEN PERMISSION FROM SCHNEIDER ELECTRIC. THIS DRAWING IS BASED UPON LATEST AVAILABLE INFORMATION AND IS SUBJECT TO CHANGE WITHOUT NOTICE.



TITLE:
REMOTE POWER PANEL
Input: 3PH, 240V/480V
Output: 3PH, 240V/480V
GENERAL ARRANGEMENT
PROJECT: SUBMITTAL DRAWING SHEET 2 OF 9

DWG NO: GRPP84 REV. 2
DRAWN BY: JAYAPRAKASH 03-JUL-20 THIRD
ENGINEER: Gerardo Esquivel 03-JUL-20 ANGLE
APPROVED BY: Gerardo Esquivel 03-JUL-20 PROJECTION

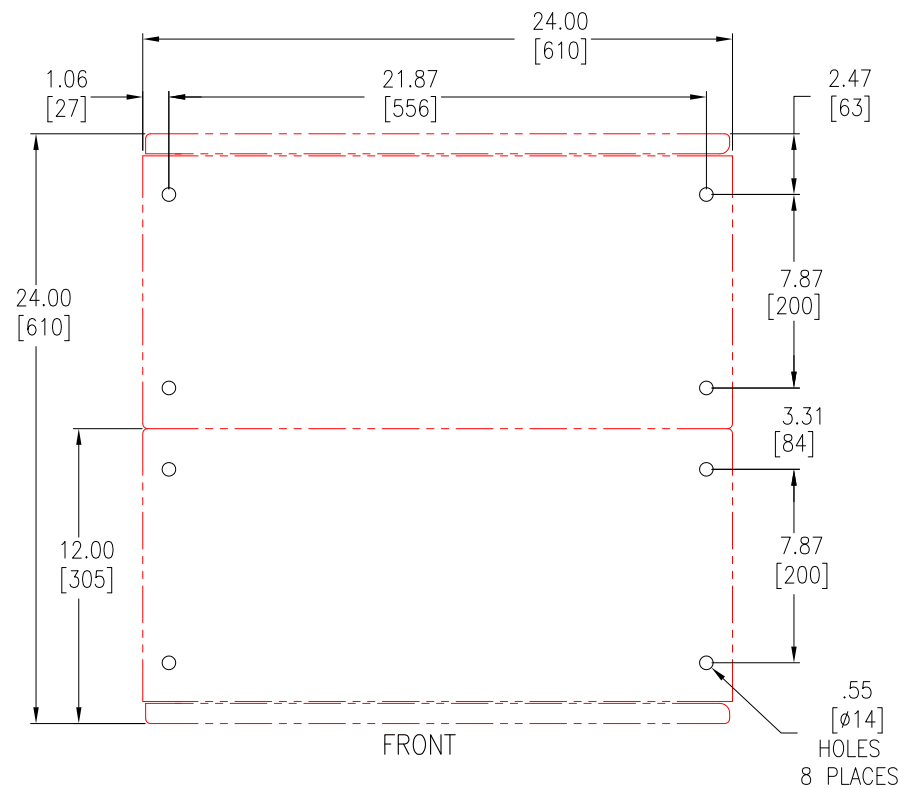
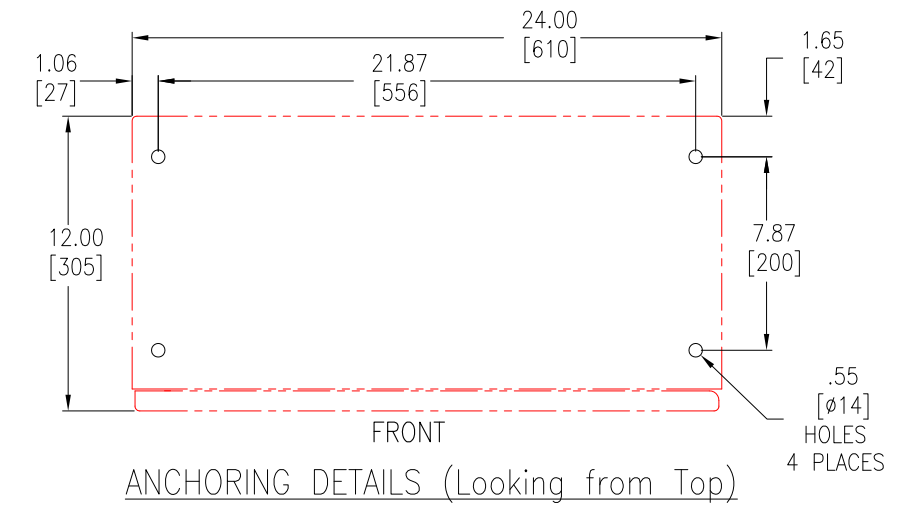
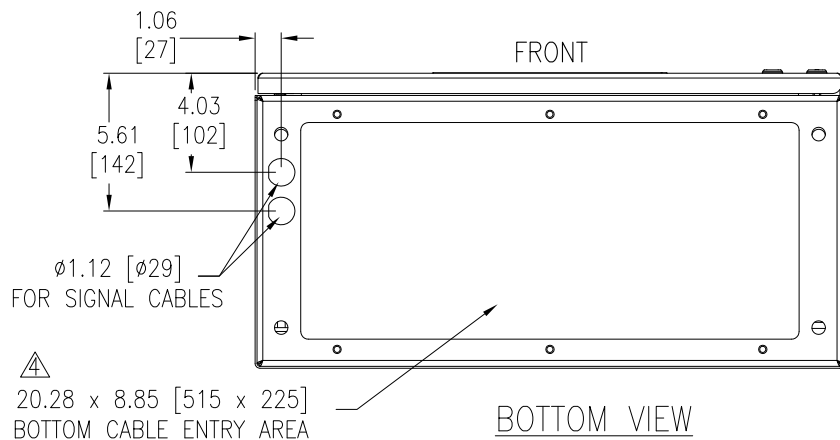
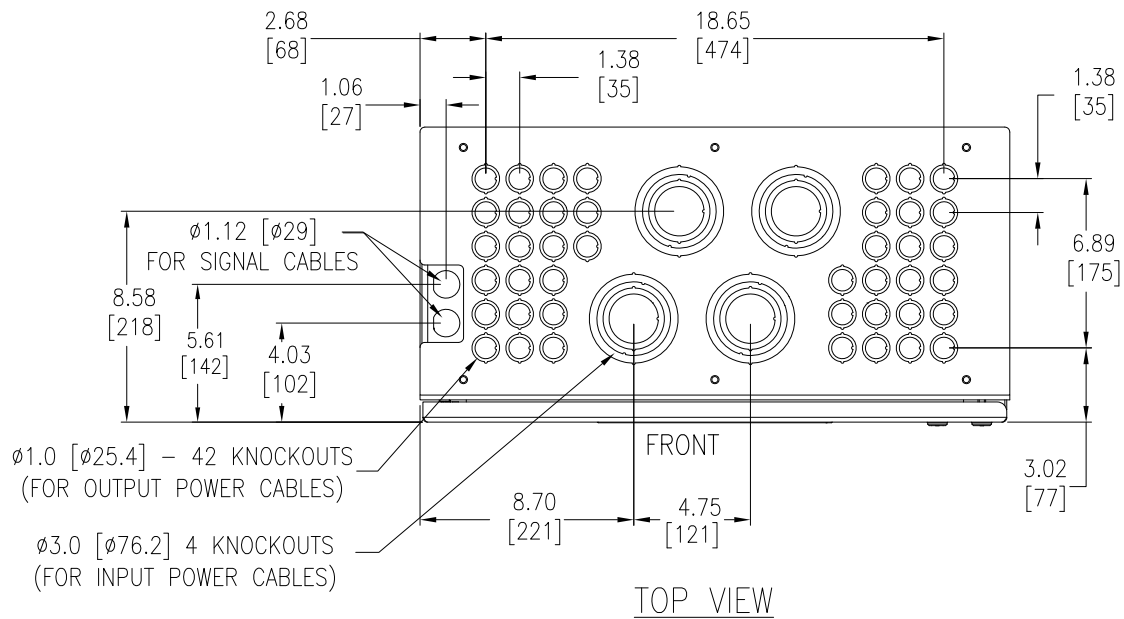

NOTES:

1. INSTALLATION SHALL COMPLY WITH ALL APPLICABLE NATIONAL, STATE AND LOCAL CODES.
2. REFER TO PRODUCT DOCUMENTATION FOR ADDITIONAL DETAILS PRIOR TO INSTALLATION AND SITE PREPARATION WORK.
3. ALL DIMENSIONS ARE IN INCHES [MILLIMETERS].
- △ 4. DRILL/PUNCH HOLES IN PLATE. REMOVE PLATE FROM CABINET BEFORE DRILLING/PUNCHING.
5. FLOOR ANCHORING BOLTS NOT PROVIDED.

THIS DRAWING AND SPECIFICATIONS HEREIN ARE THE PROPERTY OF SCHNEIDER ELECTRIC AND SHALL NOT BE COPIED, REPRODUCED OR USED IN WHOLE OR IN PART, AS THE BASIS FOR THE MANUFACTURE OR SALE OF ITEMS WITHOUT WRITTEN PERMISSION FROM SCHNEIDER ELECTRIC. THIS DRAWING IS BASED UPON LATEST AVAILABLE INFORMATION AND IS SUBJECT TO CHANGE WITHOUT NOTICE.



TITLE: REMOTE POWER PANEL
 Input: 3PH, 240V/480V
 Output: 3PH, 240V/480V
 TOP & BOTTOM VIEW, ANCHORING

PROJECT: SUBMITTAL DRAWING SHEET 3 OF 9

DWG NO: GRPP84		REV. 1
DRAWN BY: JAYAPRAKASH	03-JUL-20	THIRD
ENGINEER: Gerardo Esquivel	03-JUL-20	ANGLE
APPROVED BY: Gerardo Esquivel	03-JUL-20	PROJECTION

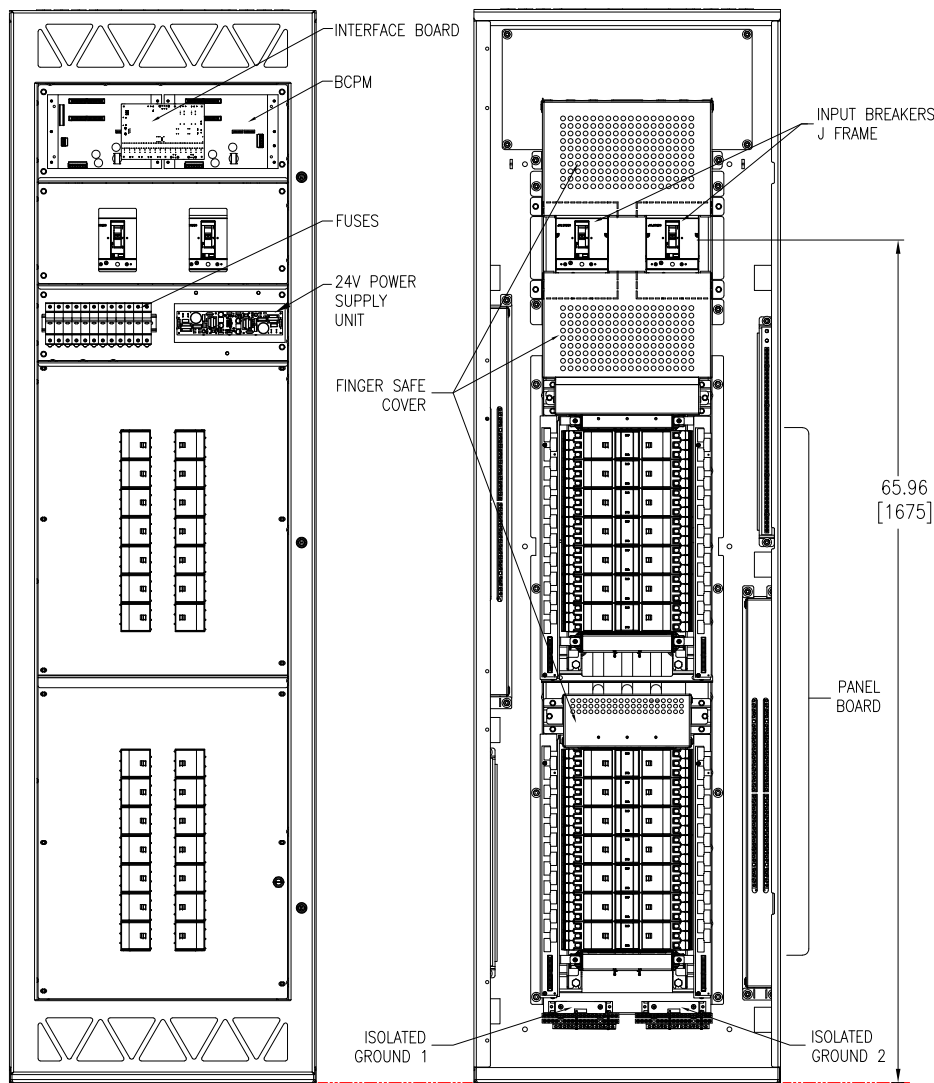

INTERNAL FRONT VIEW-IP2X 42
(DEAD FRONT DOOR COVERS REMOVED)

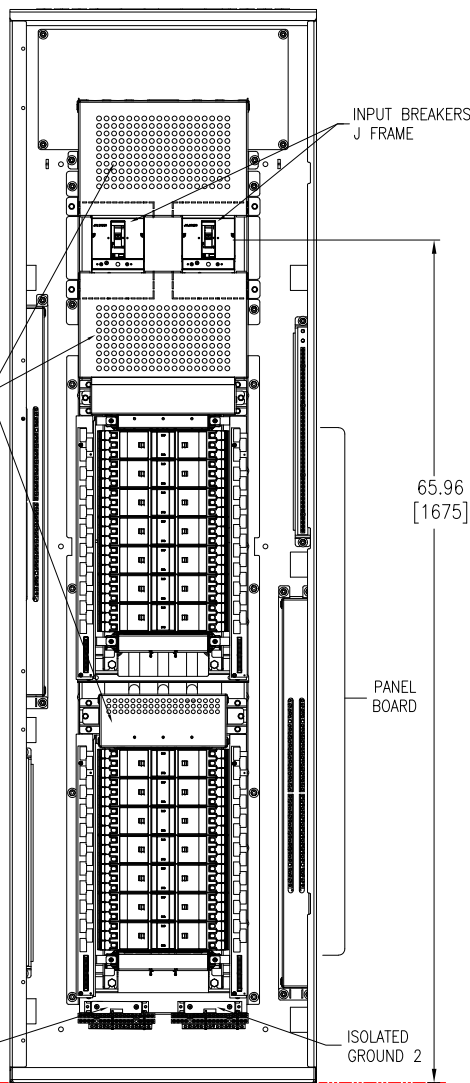

INTERNAL FRONT VIEW-IP2X 42
(DEAD FRONT DOOR REMOVED)

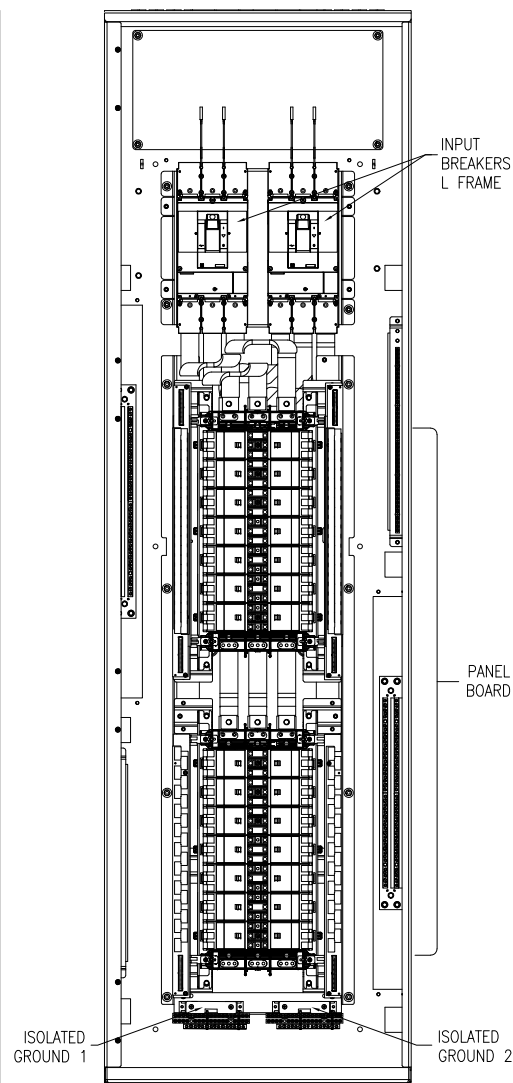

INTERNAL FRONT VIEW-NQ 42
(DEAD FRONT DOOR REMOVED)

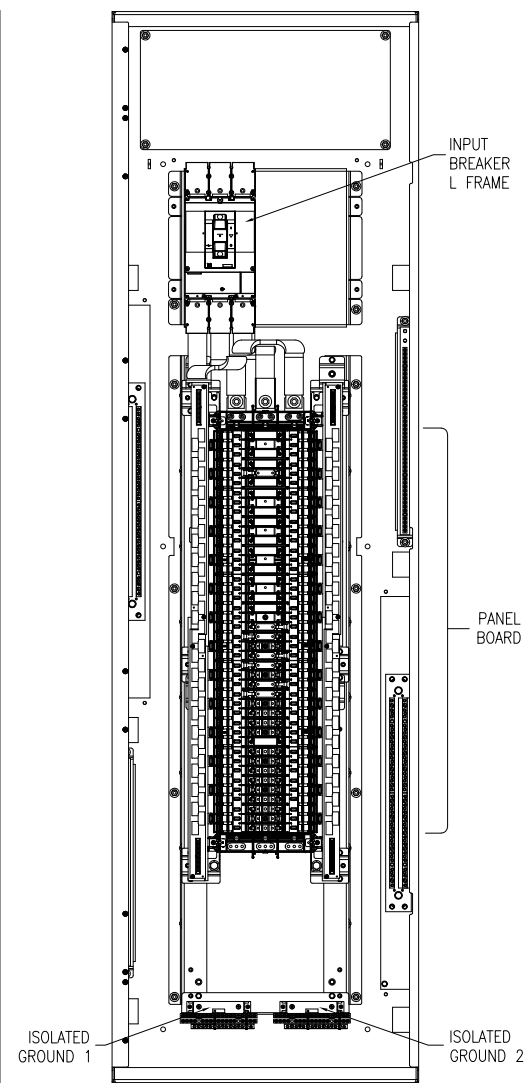

INTERNAL FRONT VIEW-NQ 84
(DEAD FRONT DOOR REMOVED)

Device	Type	Rating	Model	Breaking	Mechanical terminal wire range	Mechanical wire bending space	Compression terminal wire range (AL/CU)	Mechanical wire bending space
Main Input Breaker	Square D molded case 3 pole	250A at 80%	JGF36250U33X	65kA at 240V	3/0 AWG to 350kcmil	14.8 inches [376mm]	NEMA 2 hole lug 0.5 inch bolt, max 350 MCM	8.34 inches [212mm]
		250A at 100%	JGP36250CU33X	35kA at 480V				
		400A at 80%	LGF36400U33X	65kA at 240V	2 x 3/0 AWG to 500 kcmil	12 inches [309mm]	2 x NEMA 2 hole lug 0.5 inch bolt, max 250 MCM	8 inches [203mm]
		400A at 100%	LGF36400CU33X	35kA at 480V				

Device	Type	Sevice Voltage	Peak surge current rating per phase	Model
SPD	Voltage Surge Protection	208Y/120 V, 3 phase, 4-wire + ground	100 kA	TVS2HWA10X
		480Y/277 V, 3 phase, 4-wire + ground	100 kA	TVS4HWA10X

NOTES:

1. INSTALLATION SHALL COMPLY WITH ALL APPLICABLE NATIONAL, STATE AND LOCAL CODES.
2. REFER TO PRODUCT DOCUMENTATION FOR ADDITIONAL DETAILS PRIOR TO INSTALLATION AND SITE PREPARATION WORK.
3. ALL DIMENSIONS ARE IN INCHES [MILLIMETERS].
4. SURGE PROTECTIVE DEVICE OPTION:
208Y/120 SERIES ALSO APPLIES TO THE FOLLOWING VOLTAGE 220V/127.
480Y/277 SERIES APPLIES TO THE FOLLOWING VOLTAGES 380Y/220 AND 415Y/240.

THIS DRAWING AND SPECIFICATIONS HEREIN ARE THE PROPERTY OF SCHNEIDER ELECTRIC AND SHALL NOT BE COPIED, REPRODUCED OR USED IN WHOLE OR IN PART, AS THE BASIS FOR THE MANUFACTURE OR SALE OF ITEMS WITHOUT WRITTEN PERMISSION FROM SCHNEIDER ELECTRIC. THIS DRAWING IS BASED UPON LATEST AVAILABLE INFORMATION AND IS SUBJECT TO CHANGE WITHOUT NOTICE.



TITLE:

REMOTE POWER PANEL
Input: 3PH, 240V/480V
Output: 3PH, 240V/480V
INTERNAL DETAILS

PROJECT: SUBMITTAL DRAWING SHEET 4 OF 9

DWG NO:

GRPP84 REV. 2

DRAWN BY: JAYAPRAKASH 15-OCT-20 THIRD

ENGINEER: Gerardo Esquivel 09-NOV-20 ANGLE

APPROVED BY: Gerardo Esquivel 09-NOV-20 PROJECTION

Single Source with 1 Panel board

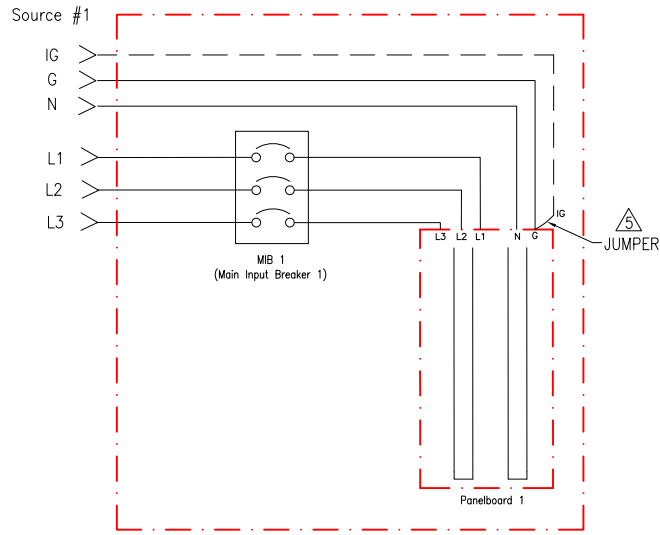

Dual Source with 2 Panel boards

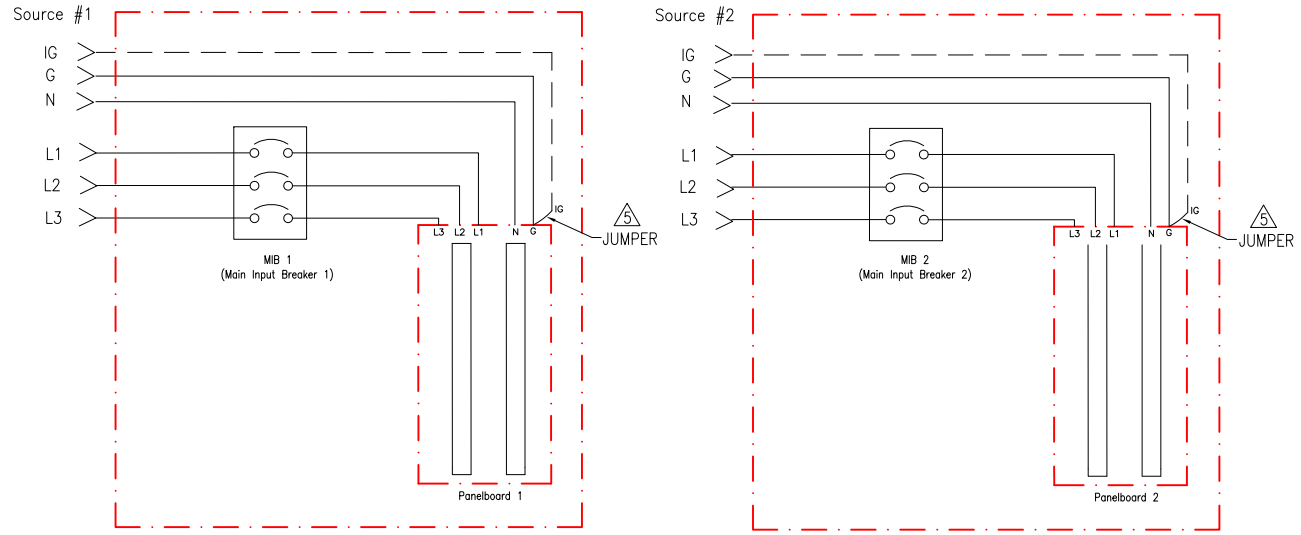

Single Source with 2 Panel boards

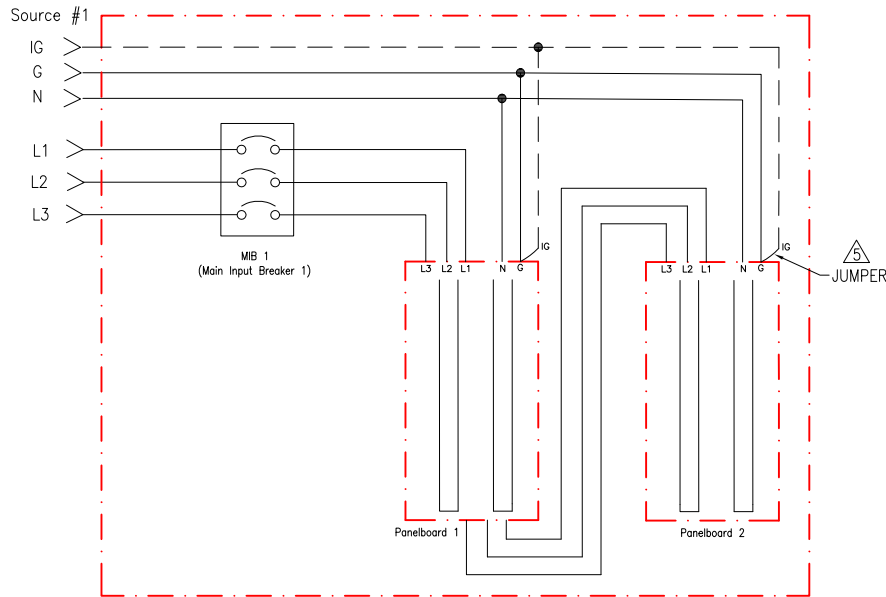

REFER TO BRANCH DISTRIBUTION SECTION IN SHEET 6 FOR AVAILABLE CONFIGURATIONS OF PANEL BOARDS AND BRANCH BREAKERS

IG: OUTPUT ISOLATED GROUND IS OPTIONAL

NOTES:

1. INSTALLATION SHALL COMPLY WITH ALL APPLICABLE NATIONAL, STATE AND LOCAL CODES.
2. REFER TO PRODUCT DOCUMENTATION FOR ADDITIONAL DETAILS PRIOR TO INSTALLATION AND SITE PREPARATION WORK.
3. AC SOURCE TO BE 240/480VAC 3PH 3WIRE + EGC (CONTACT SCHNEIDER ELECTRIC IF OTHER)
4. THE GROUNDING ELECTRODE CONDUCTOR (GEC) IS PROVIDED BY OTHERS.
- △5. ISOLATED GND JUMPER SHALL NOT BE REMOVED UNLESS IG & BUILDING GND ARE CONNECTED TOGETHER ELSEWHERE.
6. RACK FRAME AND SKIN ARE ELECTRICALLY CONNECTED AND TIED TO CHASSIS GROUND.
7. ALL AC POWER CABLING TO BE 600V RATED.

THIS DRAWING AND SPECIFICATIONS HEREIN ARE THE PROPERTY OF SCHNEIDER ELECTRIC AND SHALL NOT BE COPIED, REPRODUCED OR USED IN WHOLE OR IN PART, AS THE BASIS FOR THE MANUFACTURE OR SALE OF ITEMS WITHOUT WRITTEN PERMISSION FROM SCHNEIDER ELECTRIC. THIS DRAWING IS BASED UPON LATEST AVAILABLE INFORMATION AND IS SUBJECT TO CHANGE WITHOUT NOTICE.



TITLE:
REMOTE POWER PANEL
Input: 3PH, 240V/480V
Output: 3PH, 240V/480V
SINGLE LINE DIAGRAM
PROJECT: SUBMITTAL DRAWING **SHEET 5 OF 9**

DWG NO:	GRPP84	REV.	2
DRAWN BY:	JAYAPRAKASH	03-JUL-20	ANGLE
ENGINEER:	Gerardo Esquivel	03-JUL-20	PROJECTION
APPROVED BY:	Gerardo Esquivel	03-JUL-20	N.A

CONFIGURATIONS OF PANEL BOARDS AND BRANCH BREAKERS

Item	Family	Part number	# Poles	Description
1	QO Branch	QOB110	1	10A, 10kA @240V
2	QO Branch	QOB115		15A, 10kA @240V
3	QO Branch	QOB115VH		15A, 22kA @240V
4	QO Branch	QOB120		20A, 10kA @240V
5	QO Branch	QOB120VH		20A, 22kA @240V
6	QO Branch	QOB125		25A, 10kA @240V
7	QO Branch	QOB125VH		25A, 22kA @240V
8	QO Branch	QOB130		30A, 10kA @240V
9	QO Branch	QOB130VH		30A, 22kA @240V
10	QO Branch	QOB135		35A, 10kA @240V
11	QO Branch	QOB140		40A, 10kA @240V
12	QO Branch	QOB150		50A, 10kA @240V
13	QO Branch	QOB160		60A, 10kA @240V
14	QO Branch	QOB170		70A, 10kA @240V
15	QO Branch	QOB210	2	10A, 10kA @240V
16	QO Branch	QOB2100		100A,10kA @240V
17	QO Branch	QOB215		15A, 10kA @240V
18	QO Branch	QOB220		20A, 10kA @240V
19	QO Branch	QOB220VH		20A, 22kA @240V
20	QO Branch	QOB225		25A, 10kA @240V
21	QO Branch	QOB225VH		25A, 22kA @240V
22	QO Branch	QOB230		30A, 10kA @240V
23	QO Branch	QOB230VH		30A, 22kA @240V
24	QO Branch	QOB235		35A, 10kA @240V
25	QO Branch	QOB240		40A, 10kA @240V
26	QO Branch	QOB240VH		40A, 22kA @240V
27	QO Branch	QOB245		45A, 10kA @240V
28	QO Branch	QOB250		50A, 10kA @240V
29	QO Branch	QOB250VH		50A, 22kA @240V
30	QO Branch	QOB260		60A, 10kA @240V
31	QO Branch	QOB270		70A, 10kA @240V
32	QO Branch	QOB280		80A, 10kA @240V
33	QO Branch	QOB290		90A, 10kA @240V

Item	Family	Part number	# Poles	Description	
34	QO Branch	QOB310	3	10A, 10kA @240V	
35	QO Branch	QOB3100		100A,10kA @240V	
36	QO Branch	QOB3100VH		100A,22kA @240V	
37	QO Branch	QOB315		15A, 10kA @240V	
38	QO Branch	QOB320		20A, 10kA @240V	
39	QO Branch	QOB320VH		20A, 22kA @240V	
40	QO Branch	QOB325		25A, 10kA @240V	
41	QO Branch	QOB330		30A, 10kA @240V	
42	QO Branch	QOB330VH		30A, 22kA @240V	
43	QO Branch	QOB335		35A, 10kA @240V	
44	QO Branch	QOB340		40A, 10kA @240V	
45	QO Branch	QOB340VH		40A, 22kA @240V	
46	QO Branch	QOB345		45A, 10kA @240V	
47	QO Branch	QOB350		50A, 10kA @240V	
48	QO Branch	QOB350VH		50A, 22kA @240V	
49	QO Branch	QOB360		60A, 10kA @240V	
50	QO Branch	QOB360VH		60A, 22kA @240V	
51	QO Branch	QOB370		70A, 10kA @240V	
52	QO Branch	QOB370VH		70A, 22kA @240V	
53	QO Branch	QOB380		80A, 10kA @240V	
54	QO Branch	QOB380VH		80A, 22kA @240V	
55	QO Branch	QOB390		90A 10kA @240V	
56	QO Branch	QOB390VH		90A 22kA @240V	
57	EDB Branch	EDB14045		1	45A 18kA @480V
58	EDB Branch	EDB14070			70A, 18kA @480V
59	EDB Branch	EDB24045		2	45A, 18kA @480V
60	EDB Branch	EDB24090		2	90A, 18kA @480V
61	EDB Branch	EDB24035		2	35A, 18kA @480V
62	EDB Branch	EDB14015		1	15A, 18kA @480V
63	EDB Branch	EDB14020		1	20A, 18kA @480V
64	EDB Branch	EDB14025		1	25A, 18kA @480V
65	EDB Branch	EDB14030		1	30A, 18kA @480V
66	EDB Branch	EDB14035		1	35A, 18kA @480V

Item	Family	Part number	# Poles	Description
67	EDB Branch	EDB14040	1	40A, 18kA @480V
68	EDB Branch	EDB14050	1	50A, 18kA @480V
69	EDB Branch	EDB14060	1	60A, 18kA @480V
70	EDB Branch	EDB24015	2	15A, 18kA @480V
71	EDB Branch	EDB24020	2	20A, 18kA @480V
72	EDB Branch	EDB24025	2	25A, 18kA @480V
73	EDB Branch	EDB24030	2	30A, 18kA @480V
74	EDB Branch	EDB24040	2	40A, 18kA @480V
75	EDB Branch	EDB24050	2	50A, 18kA @480V
76	EDB Branch	EDB24060	2	60A, 18kA @480V
77	EDB Branch	EDB24070	2	70A, 18kA @480V
78	EDB Branch	EDB24080	2	80A, 18kA @480V
79	EDB Branch	EDB24100	2	100A,18kA @480V
80	EDB Branch	EDB34015	2	15A, 18kA @480V
81	EDB Branch	EDB34020	3	20A, 18kA @480V
82	EDB Branch	EDB34025	3	25A, 18kA @480V
83	EDB Branch	EDB34030	3	30A, 18kA @480V
84	EDB Branch	EDB34035	3	35A, 18kA @480V
85	EDB Branch	EDB34040	3	40A, 18kA @480V
86	EDB Branch	EDB34045	3	45A, 18kA @480V
87	EDB Branch	EDB34050	3	50A, 18kA @480V
88	EDB Branch	EDB34060	3	60A, 18kA @480V
89	EDB Branch	EDB34070	3	70A, 18kA @480V
90	EDB Branch	EDB34080	3	80A, 18kA @480V
91	EDB Branch	EDB34090	3	90A, 18kA @480V
92	EDB Branch	EDB34100	3	100A 18kA @480V

NOTES:
 1. INSTALLATION SHALL COMPLY WITH ALL APPLICABLE NATIONAL, STATE AND LOCAL CODES.
 2. REFER TO PRODUCT DOCUMENTATION FOR ADDITIONAL DETAILS PRIOR TO INSTALLATION AND SITE PREPARATION WORK.

THIS DRAWING AND SPECIFICATIONS HEREIN ARE THE PROPERTY OF SCHNEIDER ELECTRIC AND SHALL NOT BE COPIED, REPRODUCED OR USED IN WHOLE OR IN PART, AS THE BASIS FOR THE MANUFACTURE OR SALE OF ITEMS WITHOUT WRITTEN PERMISSION FROM SCHNEIDER ELECTRIC. THIS DRAWING IS BASED UPON LATEST AVAILABLE INFORMATION AND IS SUBJECT TO CHANGE WITHOUT NOTICE.



TITLE:

REMOTE POWER PANEL
 Input: 3PH, 240V/480V
 Output: 3PH, 240V/480V
 PANEL BOARDS AND BRANCH BREAKERS

PROJECT: SUBMITTAL DRAWING SHEET 6 OF 9

DWG NO:	REV.
GRPP84	0
DRAWN BY: JAYAPRAKASH	17-FEB-20
ENGINEER: Gerardo Esquivel	18-FEB-20
APPROVED BY: Gerardo Esquivel	18-FEB-20
	ANGLE PROJECTION N.A

SINGLE SOURCE WITH ONE PANEL BOARD

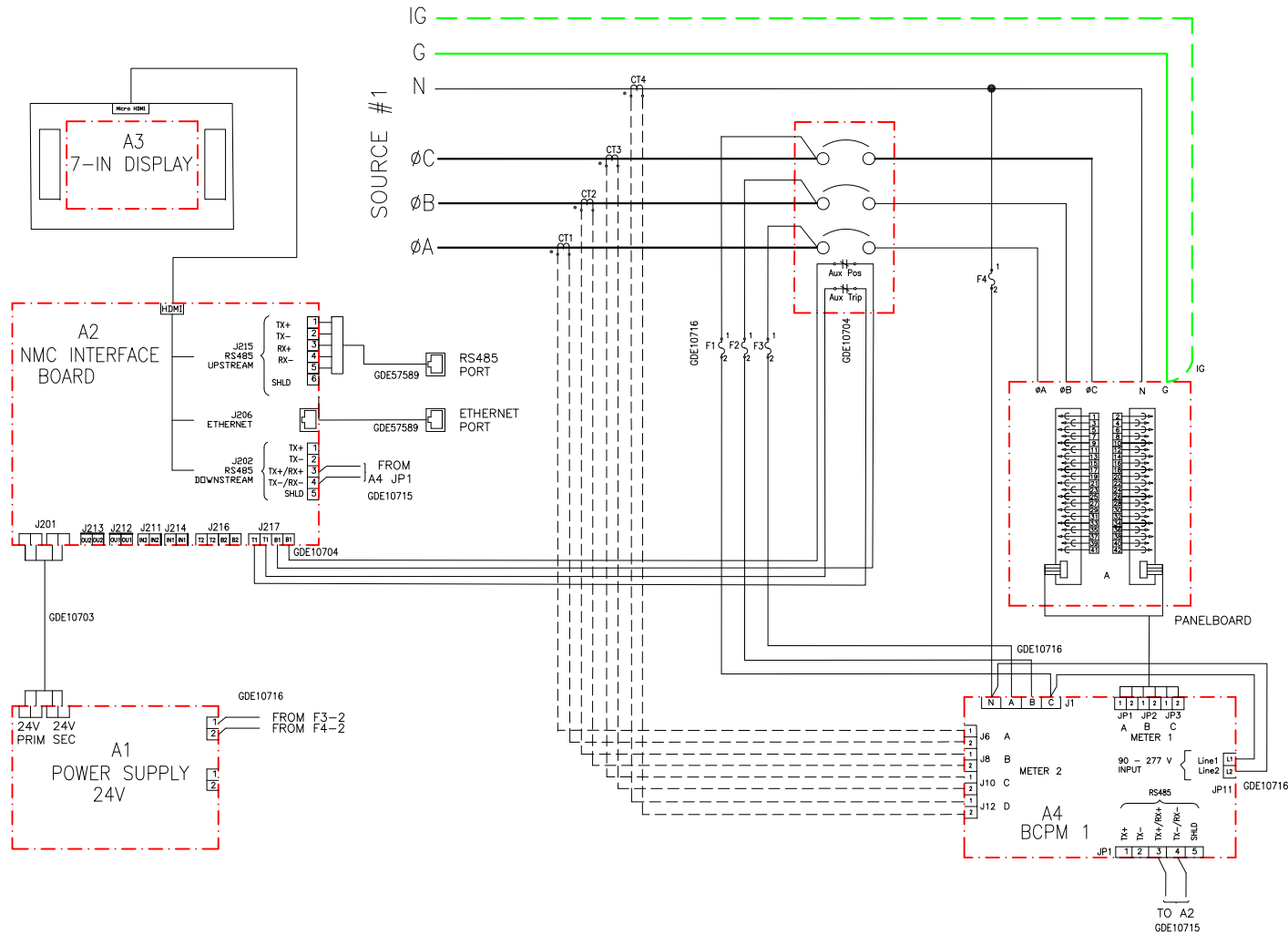

HIDDEN LINES (-----) INDICATE MAIN INPUT CT CONNECTIONS

NOTES:

1. INSTALLATION SHALL COMPLY WITH ALL APPLICABLE NATIONAL, STATE AND LOCAL CODES.
2. REFER TO PRODUCT DOCUMENTATION FOR ADDITIONAL DETAILS PRIOR TO INSTALLATION AND SITE PREPARATION WORK.

THIS DRAWING AND SPECIFICATIONS HEREIN ARE THE PROPERTY OF SCHNEIDER ELECTRIC AND SHALL NOT BE COPIED, REPRODUCED OR USED IN WHOLE OR IN PART, AS THE BASIS FOR THE MANUFACTURE OR SALE OF ITEMS WITHOUT WRITTEN PERMISSION FROM SCHNEIDER ELECTRIC. THIS DRAWING IS BASED UPON LATEST AVAILABLE INFORMATION AND IS SUBJECT TO CHANGE WITHOUT NOTICE.



TITLE:
REMOTE POWER PANEL
Input: 3PH, 240V/480V
Output: 3PH, 240V/480V
CONTROL DIAGRAM-1

PROJECT: SUBMITTAL DRAWING SHEET 7 OF 9

DWG NO:	GRPP84	REV.	0
DRAWN BY:	JAYAPRAKASH	03-JUL-20	ANGLE
ENGINEER:	Gerardo Esquivel	03-JUL-20	PROJECTION
APPROVED BY:	Gerardo Esquivel	03-JUL-20	N.A

SINGLE SOURCE WITH TWO PANEL BOARDS

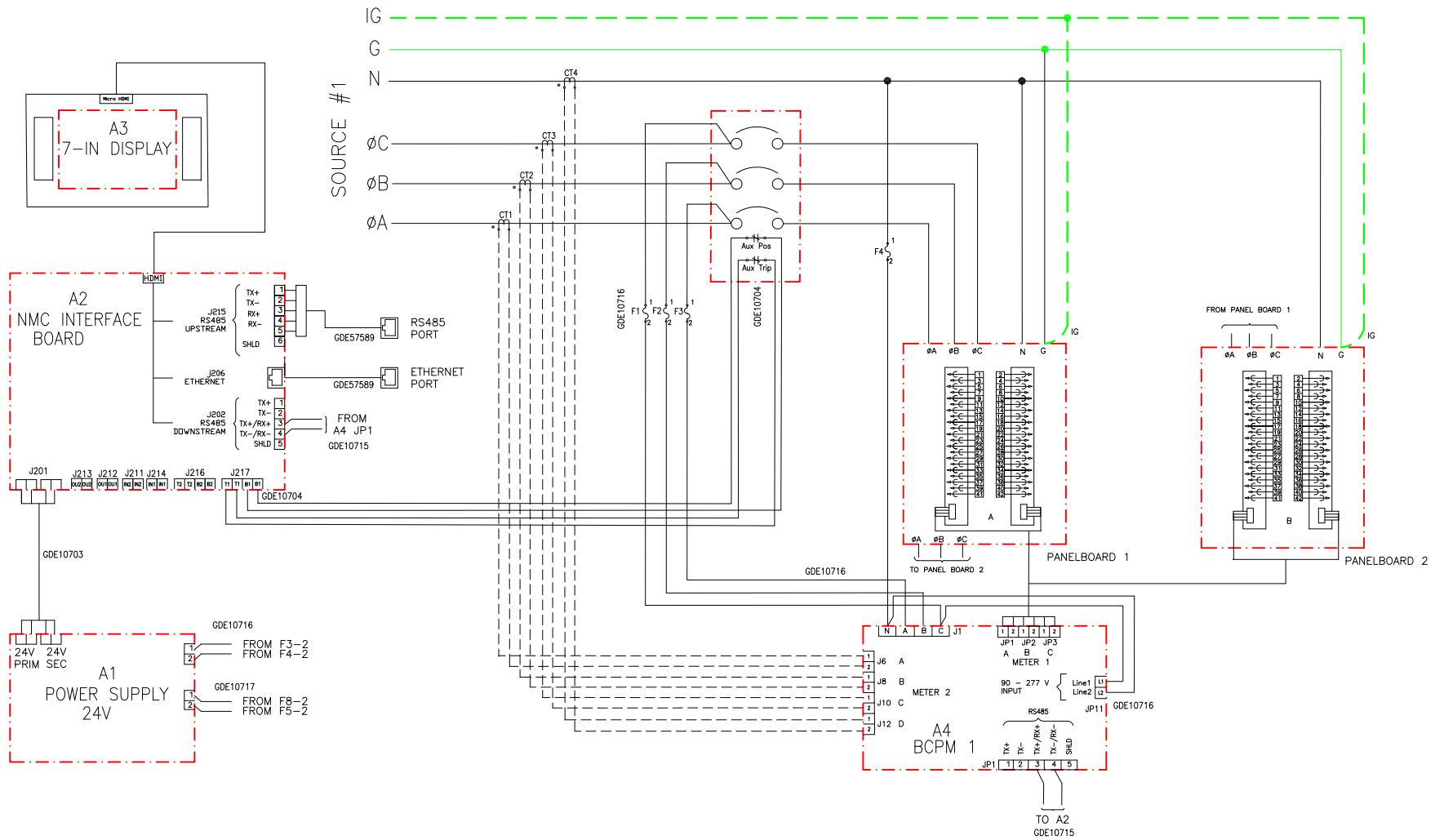

HIDDEN LINES (-----) INDICATE MAIN INPUT CT CONNECTIONS

NOTES:

1. INSTALLATION SHALL COMPLY WITH ALL APPLICABLE NATIONAL, STATE AND LOCAL CODES.
2. REFER TO PRODUCT DOCUMENTATION FOR ADDITIONAL DETAILS PRIOR TO INSTALLATION AND SITE PREPARATION WORK.

THIS DRAWING AND SPECIFICATIONS HEREIN ARE THE PROPERTY OF SCHNEIDER ELECTRIC AND SHALL NOT BE COPIED, REPRODUCED OR USED IN WHOLE OR IN PART, AS THE BASIS FOR THE MANUFACTURE OR SALE OF ITEMS WITHOUT WRITTEN PERMISSION FROM SCHNEIDER ELECTRIC. THIS DRAWING IS BASED UPON LATEST AVAILABLE INFORMATION AND IS SUBJECT TO CHANGE WITHOUT NOTICE.



TITLE:
REMOTE POWER PANEL
Input: 3PH, 240V/480V
Output: 3PH, 240V/480V
CONTROL DIAGRAM - 2

PROJECT: SUBMITTAL DRAWING **SHEET 8 OF 9**

DWG NO:	GRPP84	REV.	0
DRAWN BY:	JAYAPRAKASH	03-JUL-20	ANGLE
ENGINEER:	Gerardo Esquivel	03-JUL-20	PROJECTION
APPROVED BY:	Gerardo Esquivel	03-JUL-20	N.A

DUAL SOURCE WITH TWO PANEL BOARDS

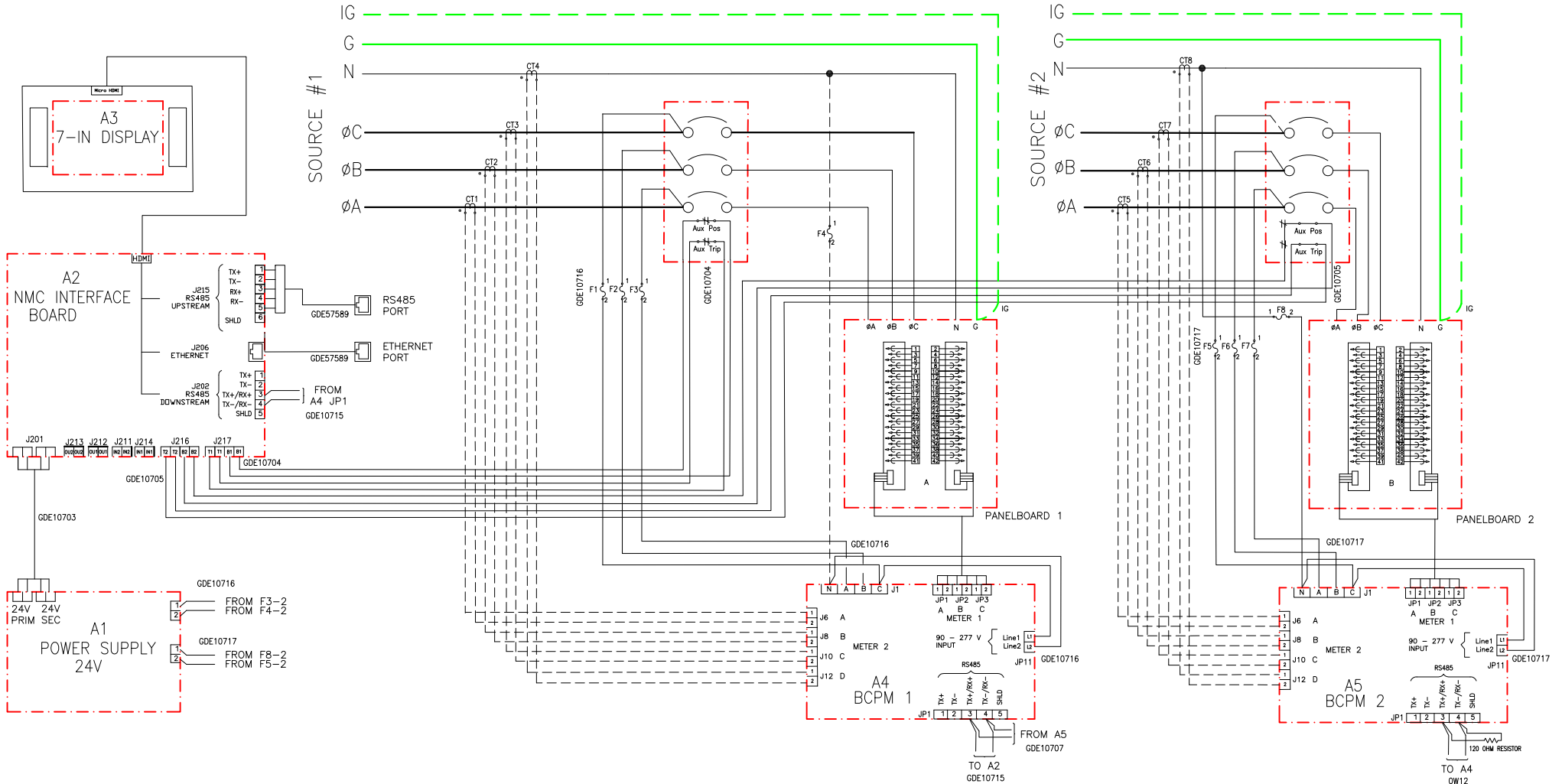

HIDDEN LINES (-----) INDICATE MAIN INPUT CT CONNECTIONS

NOTES:

1. INSTALLATION SHALL COMPLY WITH ALL APPLICABLE NATIONAL, STATE AND LOCAL CODES.
2. REFER TO PRODUCT DOCUMENTATION FOR ADDITIONAL DETAILS PRIOR TO INSTALLATION AND SITE PREPARATION WORK.

THIS DRAWING AND SPECIFICATIONS HEREIN ARE THE PROPERTY OF SCHNEIDER ELECTRIC AND SHALL NOT BE COPIED, REPRODUCED OR USED IN WHOLE OR IN PART, AS THE BASIS FOR THE MANUFACTURE OR SALE OF ITEMS WITHOUT WRITTEN PERMISSION FROM SCHNEIDER ELECTRIC. THIS DRAWING IS BASED UPON LATEST AVAILABLE INFORMATION AND IS SUBJECT TO CHANGE WITHOUT NOTICE.



TITLE:
REMOTE POWER PANEL
Input: 3PH, 240V/480V
Output: 3PH, 240V/480V
CONTROL DIAGRAM-3

PROJECT: SUBMITTAL DRAWING **SHEET** 9 OF 9

DWG NO:	GRPP84	REV.	1
DRAWN BY:	JAYAPRAKASH	03-JUL-20	ANGLE
ENGINEER:	Gerardo Esquivel	03-JUL-20	PROJECTION
APPROVED BY:	Gerardo Esquivel	03-JUL-20	N.A