

**en** Installation Guide

EVlink Pro DC 60 Charging Station



Wall Mounting



Floor Mounting

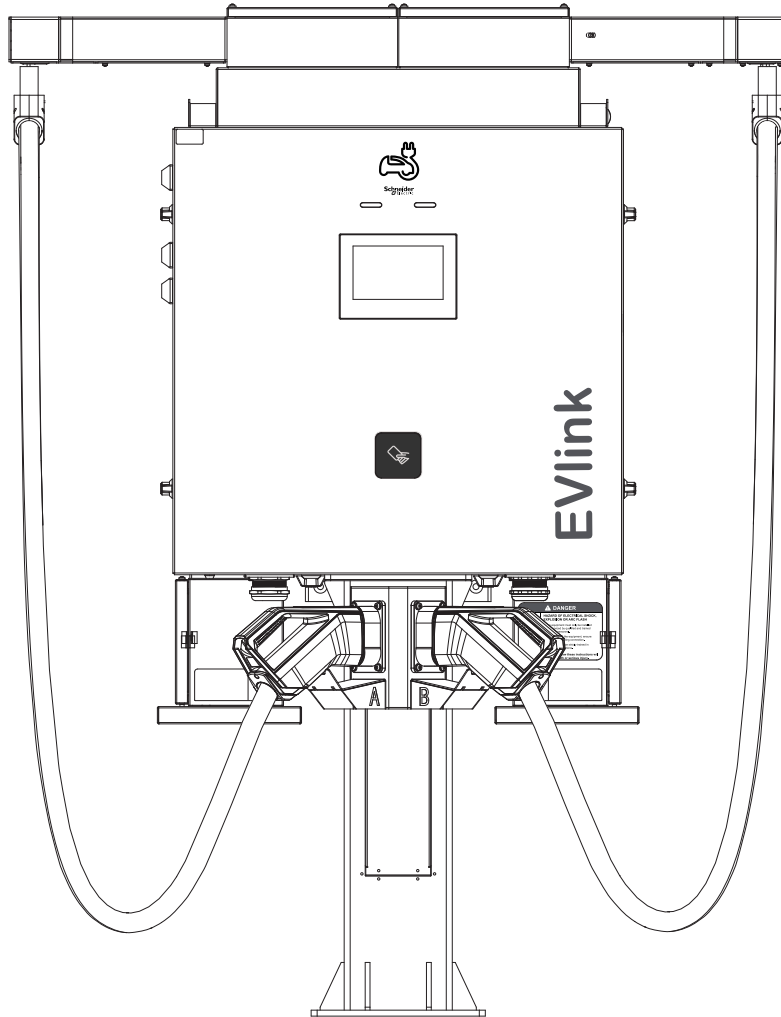

**Customer Care Center**

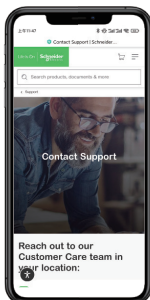

<b>Legal Information</b> .....	<b>3</b>
<b>General</b> .....	<b>3</b>
<b>Radio Equipment Conformity</b> .....	<b>4</b>
<b>Important</b> .....	<b>5</b>
<b>Preface</b> .....	<b>5</b>
<b>1. System Overview</b> .....	<b>6</b>
<b>2. Installation Environment</b> .....	<b>6</b>
<b>3. Site Preparation</b> .....	<b>7</b>
3.1 Maintenance Distance .....	7
3.2 Floor Standing Site Requirements .....	8
3.3 Wall mounted Site Requirements.....	9
3.4 Ventilation Requirements .....	10
3.5 Parking Place Arrangements Layout.....	10
3.6 Signage and Location .....	12
3.7 Bollards .....	12
3.8 Tilt / Collision Sensor .....	12
<b>4. Electrical Requirements</b> .....	<b>12</b>
<b>5. Communication</b> .....	<b>13</b>
<b>6. Required Materials and Tools</b> .....	<b>13</b>
<b>7. Receiving, Handling</b> .....	<b>13</b>
7.1 Receiving .....	13
7.2 Contents.....	13
<b>8. Unpacking and Inspection</b> .....	<b>15</b>
8.1 Unpacking .....	15
8.2 Inspection.....	15
<b>9. Handling and Mounting</b> .....	<b>16</b>
9.1 Handling and Fixing in Place .....	16
9.2 Wall mounted Installation .....	16
9.3 Floor Standing Installation .....	17
<b>10. Connecting</b> .....	<b>19</b>
10.1 Ethernet Connection (Optional) .....	20
10.2 Installation of 4G SIM Card (Optional).....	21
10.3 After connection .....	21
<b>11. Installation of Power Module</b> .....	<b>22</b>
<b>12. Cable Management</b> .....	<b>22</b>
12.1 Cable Management System Installation (Optional).....	22
<b>13. Finalization</b> .....	<b>25</b>
<b>14. Startup / Shutdown</b> .....	<b>25</b>
14.1 Startup .....	26
14.2 Shutdown .....	26
<b>15. Hide Emergency charge stop button (Optional)</b> .....	<b>26</b>
<b>16. Recycle</b> .....	<b>26</b>
<b>Appendix 1: Installation Review Checklist</b> .....	<b>27</b>
<b>Appendix 2: Charging Station Mounting Template</b> .....	<b>28</b>
<b>Appendix 3: Schematic Diagram</b> .....	<b>29</b>

# Legal Information



The Schneider Electric brand and any trademarks of Schneider Electric SE and its subsidiaries referred to in this guide are the property of Schneider Electric SE or its subsidiaries.

All other brands may be trademarks of their respective owners.

This guide and its content are protected under applicable copyright laws and furnished for informational use only.

No part of this guide may be reproduced or transmitted in any form or by any means (electronic, mechanical, photocopying, recording, or otherwise), for any purpose, without the prior written permission of Schneider Electric.

Schneider Electric does not grant any right or license for commercial use of the guide or its content, except for a non-exclusive and personal license to consult it on an "as is" basis.

Schneider Electric products and equipment should be installed, operated, serviced, and maintained only by qualified personnel.

As standards, specifications, and designs change from time to time, information contained in this guide may be subject to change without notice. To the extent permitted by applicable law, no responsibility or liability is assumed by Schneider Electric and its subsidiaries for any errors or omissions in the informational content of this material or consequences arising out of or resulting from the use of the information contained herein.

## General

### Warning Symbols Definitions

The following safety messages may appear throughout this manual or on the equipment to warn of potential hazards or to call attention to information that clarifies or simplifies a procedure.



The addition of this symbol to a "Danger" or "Warning" safety message indicates that an electrical hazard exists which will result in personal injury if the instructions are not followed.



This is the safety alert symbol.

It is used to alert you to potential personal injury hazards.

Obey all safety messages that follow this symbol to avoid possible injury or death.

#### ▲ DANGER

**DANGER** indicates a hazardous situation which, if not avoided, will result in death or serious injury.

#### ▲ WARNING

**WARNING** indicates a hazardous situation which, if not avoided, could result in death or serious injury.

#### ▲ CAUTION

**CAUTION** indicates a hazardous situation which, if not avoided, could result in minor or moderate injury.

#### NOTICE

**NOTICE** is used to address practices not related to physical injury.

## Safety Instructions

#### ▲ ▲ DANGER

##### HAZARD OF ELECTRICAL SHOCK, EXPLOSION OR ARC FLASH

- Apply appropriate personal protective equipment (PPE) and follow safe electrical work practices or equivalent local standards.
- This equipment must only be installed, commissioned and serviced by qualified electrical personnel.
- Turn off all power supplying this equipment before working on or inside equipment.
- Always use a properly rated voltage sensing device to confirm power is off.
- Do not use this product if the enclosure, EV cable, or the EV connector is broken, cracked, open, or shows any other indication of damage.
- Do not put fingers or objects into the electric vehicle connector.
- The use of extension DC cables or vehicle connector adapters is not permitted.

**Failure to follow these instructions will result in death or serious injury.**

#### ▲ WARNING

##### RISK OF BURNING

- Do not store flammable and explosive materials near the charging station.
- In case of overheating or fire starting near the charging station, press the emergency charge stop button of the charging station and unplug the car. Move away from the charging station and call the fire department.

**Failure to follow these instructions can result in death, serious injury, or equipment damage.**

#### ▲ CAUTION

##### HAZARD OF DEGRADATION OF EQUIPMENT PERFORMANCE

- You must be a licensed electrician and complete a training course to become a EVlink Pro DC Charging Station certified installer.
- Schneider Electric will not accept any liability for consequences arising from the use of this material. Do not modify any mechanical or electrical parts.
- A qualified person is a person who has the skills and know-how relating to the construction, installation and operation of electrical equipment and who has received a safety training which enables him/her to recognize and avoid risks.

**Failure to follow these instructions can result in injury or equipment damage.**

## NOTICE

### RISK OF DAMAGING

- EVlink Pro DC Charging Station should be installed, operated, serviced and maintained only by qualified personnel.
  - Schneider Electric will not accept any liability for consequences arising from the use of this material.
  - A qualified person is a person who has the skills and know-how relating to the construction, installation and operation of electrical equipment and who has received a safety training which enables him/her to recognize and avoid risks.
- Failure to follow these instructions can result in equipment damage.**

## Radio Equipment Conformity

### EU Declaration of Conformity

EVlink Pro DC 60 is in compliance with the essential requirements and other relevant provisions of Radio Equipment Directive: 2014/53/EU. The EU declaration of conformity for EVlink Pro DC 60 offer (EU1006212-3) can be downloaded on: [www.se.com/docs](http://www.se.com/docs).

### UK Declaration of Conformity

EVlink Pro DC 60 is in compliance with the essential requirements and other relevant provisions. of Radio Equipment Regulations 2017-UK SI 2017 No.1206.

The UK declaration of conformity for EVlink Pro DC 60 offer (UK1006213-1) can be downloaded on: [www.se.com/uk/docs](http://www.se.com/uk/docs).

## Communication Frequencies

Communication Frequency	Operation Frequency	Output Power
WiFi 2.4G	2412-2483.5 MHz	16.99 dBm
RFID:	13.56 MHz	Far less than 20 mW
GSM900:	TX: 880 MHz to 915 MHz RX: 925 MHz to 960 MHz	26.63 dBm
GSM1800:	TX: 1710 MHz to 1785 MHz RX: 1805 MHz to 1880 MHz	24.77 dBm
WCDMA		
Band1:	TX: 1920 MHz to 1980 MHz RX: 2110 MHz to 2170 MHz	26.53 dBm
Band5:	TX: 824 MHz to 849 MHz RX: 869 MHz to 894 MHz	25.19 dBm
Band8:	TX: 880 MHz to 915 MHz RX: 925 MHz to 960 MHz	25.8 dBm
LTE		
Band1:	TX: 1920 MHz to 1980 MHz RX: 2110 MHz to 2170 MHz	26.53 dBm
Band3:	TX: 1710 MHz to 1785 MHz RX: 1805 MHz to 1880 MHz	26.99 dBm
Band5:	TX: 824 MHz to 849 MHz RX: 869 MHz to 894 MHz	25.19 dBm
Band7:	TX: 2500 MHz to 2570 MHz RX: 2620 MHz to 2690 MHz	27.99 dBm
Band8:	TX: 880 MHz to 915 MHz RX: 925 MHz to 960 MHz	25.8 dBm
Band20:	TX: 832MHz to 862 MHz RX: 791 MHz to 821 MHz	25.44 dBm
Band28:	TX: 703 MHz to 748 MHz RX: 758 MHz to 803 MHz	26.81 dBm
Band38:	2570 MHz - 2620 MHz (TDD)	27.08 dBm
Band40:	2570 MHz - 2620 MHz (TDD)	26.9 dBm

## Standards and Compliance

Directive RE: 2014/53/UE	RE Directive: 2014/53/EU
Directive RoHS: 2011/65/UE, 2015/863/UE	RoHS Directive: 2011/65/EU, 2015/863/EU

### Based on following standards:

EN IEC 61851-1: 2019, EN 61851-1: 2011, EN 61851-23:2014+AC:2016-06, EN 61851-24:2014 + AC:2015,

EN 61000-6-2: 2005 + AC:2005, EN IEC 61000-6-2:2019\*, EN 61000-6-4: 2007 + A1:2011, EN IEC 61000-6-4:2019\*\*, EN IEC 61851-21-2:2021\*\*\*,

EN 301 489-1 V1.9.2(2011-09), EN 301 489-1 V2.2.3(2019-11)\*\*\*\*,

N 301 489-3 V2.3.2(2023-01), EN 301 489-17 V3.3.1(2024-09),EN 301 489-52 V1.3.1(2024-11)

N 300 330 V2.1.1(2017-02), EN 301 511 V12.5.1(2017-03), EN 301 908-1 V15.2.1 (2023-01),

EN 301 908-13 V13.2.1(2022-02), EN 301 908-13 V13.3.1(2024-10)\*\*\*\*\*, EN 300 328 V2.2.2(2019-07)

EN 301 908-2 V13.1.1 (2020-06), EN 301 908-13 V13.2.1 (2022-02), EN 300 328 v2.2.2, EN 62311:2008, EN IEC 62311:2020

IEC 61439-7:2018

EN ISO 15118-1:2019, EN ISO 15118-2:2016, EN ISO 15118-3:2016, EN ISO 15118-4:2019, EN ISO 15118-5:2019

EN IEC 63000: 2018

EN 18031-1:2024, EN 18031-2:2024, EN 18031-3:2024

\* The EN IEC 61000-6-2:2019 is not an harmonized standard but the EVlink Pro DC 60kW is already compliant with EN IEC 61000-6-2:2019.

\*\* The EN IEC 61000-6-4:2019 is not an harmonized standard but the EVlink Pro DC 60kW is already compliant with EN IEC 61000-6-4:2019.

\*\*\* The EN IEC 61851-21-2:2021 is not an harmonized standard but the EVlink Pro DC 60kW is already compliant with EN IEC 61851-21-2:2021.

\*\*\*\* The EN 301 489-1 V2.2.3(2019-11) is not an harmonized standard but the EVlink Pro DC 60kW is already compliant with EN 301 489-1 V2.2.3(2019-11).

\*\*\*\*\* The EN 301 908-13 V13.3.1(2024-10) is not an harmonized standard but the EVlink Pro DC 60 V2 is already compliant with EN 301 908-13 V13.3.1(2024-10).

# Important



To help you make the best use of your Charging Station, we have prepared this manual with the utmost care. It provides all the information you need to prepare for the installation and to install your equipment. We urge you to read it attentively and follow its instructions.

- The product must be installed according to the specifications and requirements as defined by Schneider Electric. No responsibility is assumed by Schneider Electric if these requirements are not respected.
- Non-approved installation methods are performed at the risk of the contractor and void the (limited) warranty.
- Under no circumstances will compliance with the information in this manual relieve the user of his/her responsibility to comply with all applicable codes or safety standards.
- This document describes the most used installation and mounting scenarios.
- If situations arise in which it is not possible to perform an installation following the procedures provided in this document, contact Schneider Electric.
- Schneider Electric is not responsible for any damages that may result from custom installations that are not described in this document or for any failure to adhere to installation recommendations.

## Preface

This guide describes the planning and physical installation of the EVlink Pro DC 60 Charging Stations. The EVlink Pro DC Charging Stations are easy to install DC fast Charging Stations for electric vehicles. Fast Charging Stations are electrical installations with high electric currents. Therefore, the installation must be planned carefully, and must be done by certified personnel only (according to local standards).

EVlink Pro DC 60 is available in different versions. The different versions are described in the scope of application section.

**NOTE:** Installing the EVlink Pro DC 60 Charging Station requires at least two people and takes approximately 1-2 hours. This time estimate does not include the time needed to commission the Charging Station.

## Scope of Application

Type of equipment applicable to this manual: EVlink Pro DC 60 kW  
List of references supported are:

Commercial Reference	Nominal Power	Vehicle connector	Cable management	Cable range (m)
EVD1S60TBB	60 kW DC	2 x CCS2	Yes	3.5
EVD1S60THB	60 kW DC	1 x CCS2 + 1 x CHAdeMO	Yes	3.5
EVD1S60TBBC5	60 kW DC	2 x CCS2	No	5
EVD1S60THBC5	60 kW DC	1 x CCS2 + 1 x CHAdeMO	No	5
EVD1S60TBBC7	60 kW DC	2 x CCS2	No	7
EVD1S60TBB-AN	60 kW DC	2 x CCS2	Yes	3.5
EVD1S60THB-AN	60 kW DC	1 x CCS2 + 1 x CHAdeMO	Yes	3.5
EVD1S60TBBC7-AN	60 kW DC	2 x CCS2	No	7
EVD1S60TBB-SA	60 kW DC	2 x CCS2	Yes	3.5

\*For more customized commercial reference, please contact Schneider Electric.

### ⚠ CAUTION

#### RISK OF TRIPPING ON LOOSE CABLE

- For versions not equipped with cable management system, it is mandatory to allocate a solution or space to place the cable in order to prevent cars from running on it.

**Failure to follow these instructions can result in injury or equipment damage.**

## Available Documentation

EVlink Pro DC available documents for each phase of the project:

Document	Reference	Content	Audiences
EVlink Pro DC Datasheet	998-23338698	Full Charging Station specifications	Site designer, installer, and station operator
EVlink Pro DC Installation Guide	GEX6836301	Civil, mechanical, and electrical installation guidelines	Site engineer or installer / contractor
EVlink Pro DC Owners Guide	GEX6836201	Operation and maintenance guidelines	Site operator and end user
EVlink Pro DC OCPP Guide	DOCA0311_IEC	Integration rule of charger for Charge Point Operator	Charge Point Operator / Contractor
EVlink Pro DC Cybersecurity Guide	DOCA0310EN_IEC	Cybersecurity rules and guidelines	Charge Point Operator / Contractor
EVlink Pro DC Modbus Connectivity Guide	D3973815	Modbus connectivity guidelines for energy management system integration	Charge Point Operator / Contractor

# 1

## System Overview

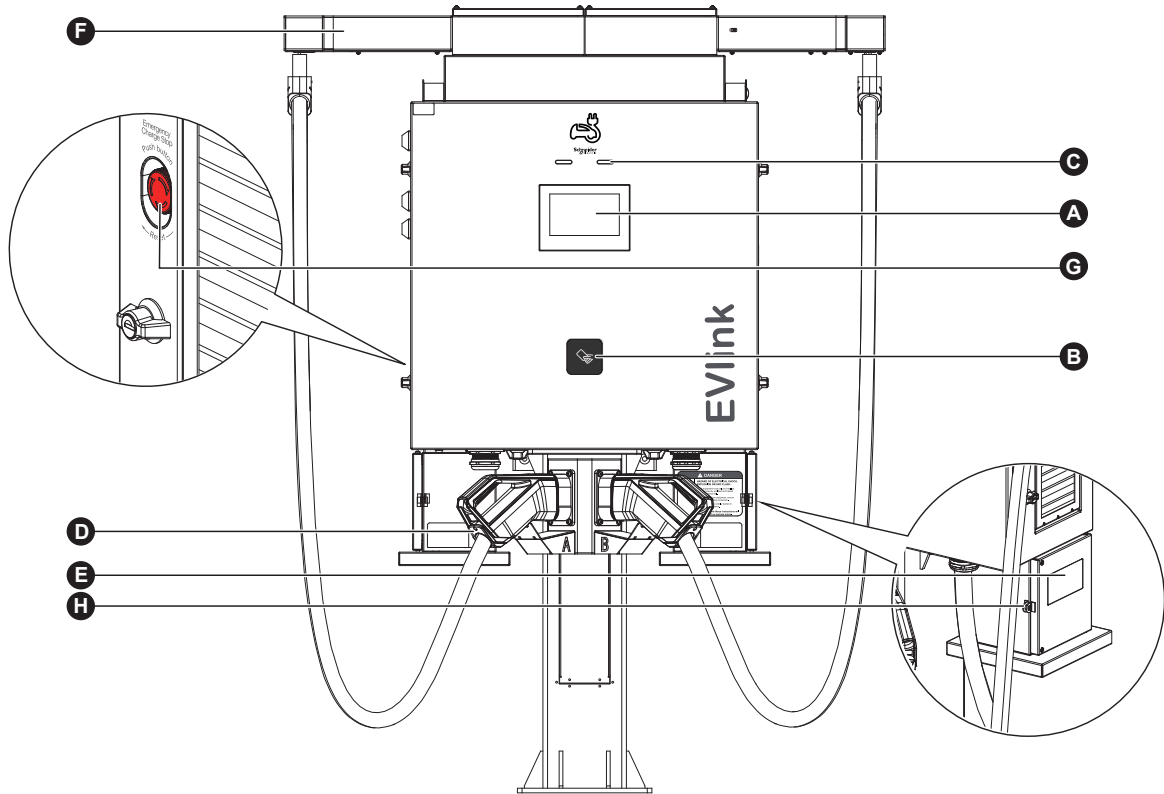

<b>A</b>	Touch screen
<b>B</b>	Card tapping area
<b>C</b>	Indicator lights
<b>D</b>	Vehicle connector slot
<b>E</b>	DC Electric meter
<b>F</b>	Cable Management System
<b>G</b>	Emergency Charge Stop
<b>H</b>	Lock ring*

\*for padlock if required

Image showing version equipped with cable management system and credit card reader.

# 2

## Installation Environment

The environmental conditions listed in the table below should be taken into consideration when selecting the installation site of the EVlink Pro DC Charging Station.

Environmental parameter	Permissible Conditions
EMC environment	Industrial environment – Class A
Ambient temperature	-30°C ~ 50°C, derating after 50°C
Humidity	5%~ 95%
Altitude	Up to 2000 m
Degree of protection	IP55
Mechanical impact protection	IK10 (IK08 for screen)
Pollution degree	PD2
Mounting method	Stationary equipment, ground mounted, floor mounted or wall mounted.
Ambience	Non explosive environments Housing corrosion protection level C3M Example of environment <ul style="list-style-type: none"> <li>■ Outdoor: Urban and industrial atmospheres, moderate sulphur dioxide pollution; coastal area with low salinity</li> <li>■ Indoor: Production rooms with high humidity and some air pollution</li> </ul>
Location	Avoid accumulation of sand, dust, snow with non-restricted access

**NOTE:** Contact Schneider Electric if the Charging Station will be installed closer than 4 km to a sea/ocean coastline.

## 3.1 Maintenance Distance

The EVlink Pro DC 60 Charger can be installed floor standing on a pedestal or wall mounted.

**NOTICE****RISK OF EQUIPMENT DAMAGE**

Always follow the instructions described below when Charging Stations need to be installed near walls or other obstacles, a certain maintenance distance needs to be allocated.  
**Failure to follow these instructions can result in equipment damage.**

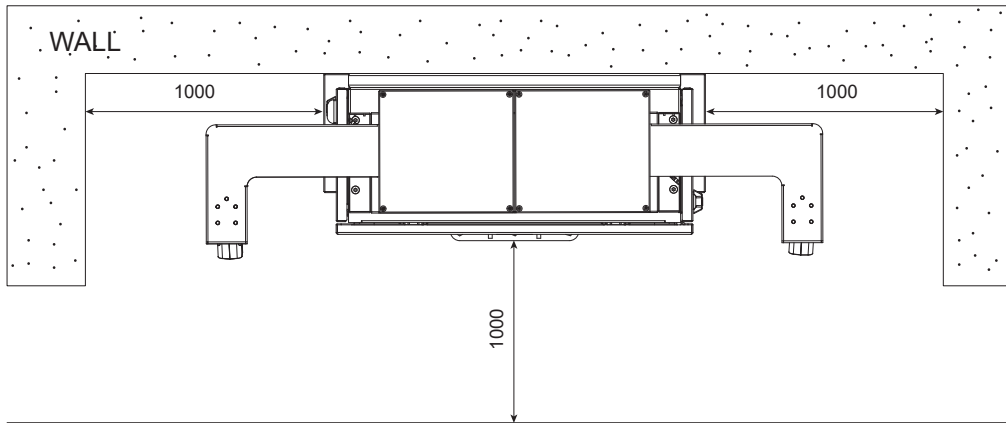

Wall Mounted Service Clearances

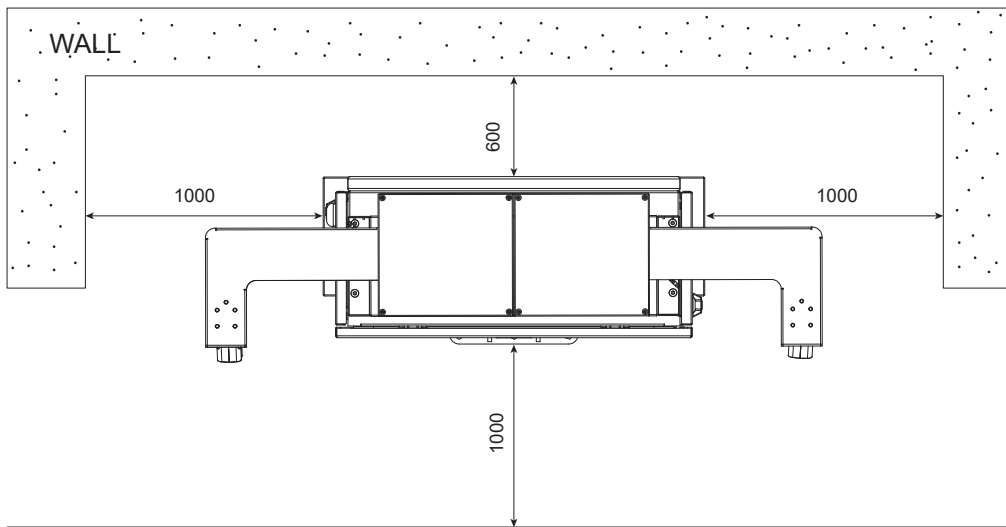

Floor Standing Service Clearances

**NOTE:** Ensure that enough space is available around the installation pad to use a forklift and other lifting equipment, unpack crates, remove packing materials, and allow two people to freely move throughout the area.  
 For versions equipped with Cable Management System, It is recommended to allow for 500 mm clear space above the Charging Station to allow for maintenance.

## 3.2 Floor Standing Site Requirements

The EVlink Pro DC 60 can be installed on a concrete base. Details on how to prepare this base are described in this section. The dimension of concrete foundation can be adjusted according to customer's requirements and actual conditions on site.

### ▲ WARNING

#### HAZARD OF HEAVY EQUIPMENT FALLING

- The EVlink Pro DC shall be mounted on concrete flooring. If the Charging Station will be installed outdoors in sandy or soil ground or on a frost line, a concrete base is mandatory.
  - Always follow the instructions and information provided in this guide or a Schneider Electric-approved mounting solution, to install the EVlink Pro DC 60.
  - Non-approved installation methods are performed at the risk of the contractor and void the limited warranty.
- Failure to follow these instructions can result in death, serious injury, or equipment damage.**

Before beginning work, check that the site meets these civil and mechanical requirements outlined below, as illustrated in the following image. Measurements are in mm.

#### 1. Underground concrete base guidelines

- The concrete pad must have a site drawing approved by a structural engineer for this specific site considering the soil behavior and/or any frost line and conforms to the mentioned specifications.
- Ensure a flat surface level with slight outward slope to drain any water, ensuring no obstacles prevent water draining from the base.
- The top of the concrete base must not be lower than the 0 finish floor level. However it may be higher according to the different site situations and local regulations.
- Please consider the height of the screen and the vehicle connector when designing the concrete base elevation.

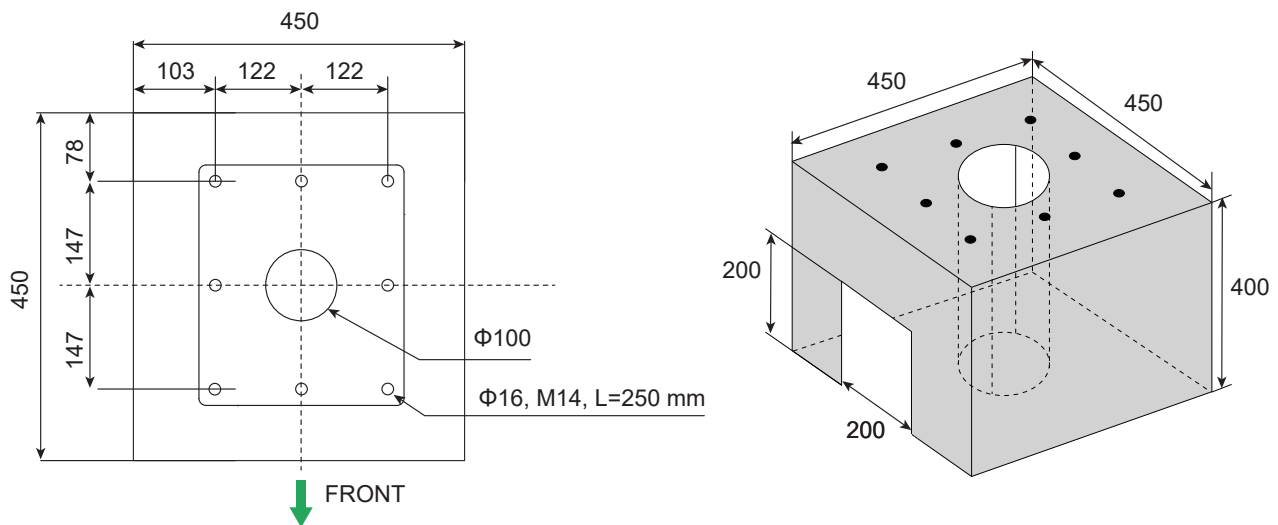

After the concrete has dried, 8 M14 screws with length  $L = 250$  mm are fixed into the concrete pad according to the provided template (Appendix 2) with 30-40mm of threads exposed.

#### 2. Floor Standing Installation & Construction Details

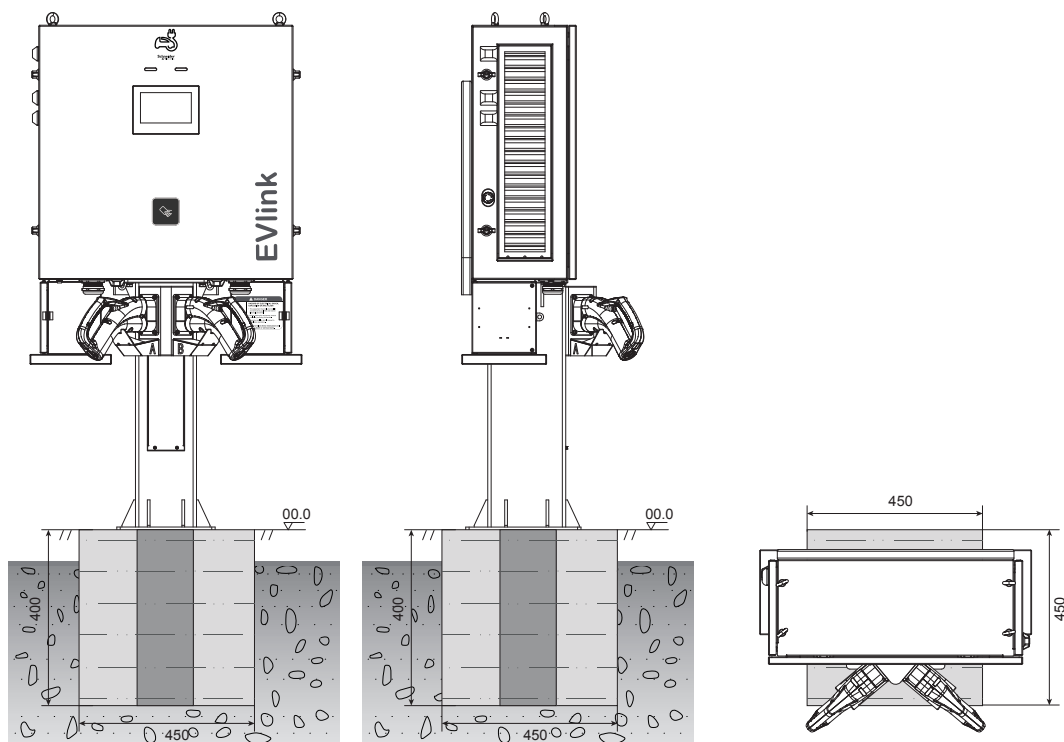

### 3.3 Wall mounted Site Requirements

The EVlink Pro DC 60 can be installed on the wall. Details on how to prepare the wall for installation are described in this section.

#### ▲ WARNING

##### HAZARD OF EQUIPMENT FALLING

- Always follow the instructions on this guide to install correctly the equipment.
  - Ensure that the wall can hold an equipment with weight > 160kg
  - Always follow the provided Wall Mounting Dimension Template shown in this document, or a Schneider Electric-approved mounting solution, to install the EVlink Pro DC.
  - Non-approved installation methods are performed at the risk of the contractor and void the Limited Warranty.
- Failure to follow these instructions can result in death, serious injury, or equipment damage.**

#### 1. Wall Installation Preparation steps:

- (1) Define the wall where the charger is to be installed
- (2) Check the evenness of the wall, and Make sure it complies with the figure showing below.

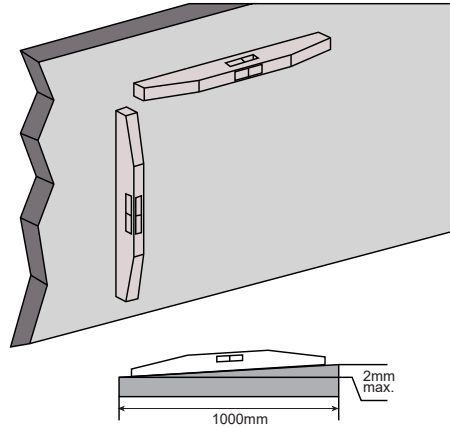

- (3) Mark the wall with the mounting hole positions of the wall mounted charger, according to the template provided with the charger.

**Note:** Select a suitable position on the wall and make sure it complies with local regulations and/or accessibility to disable people

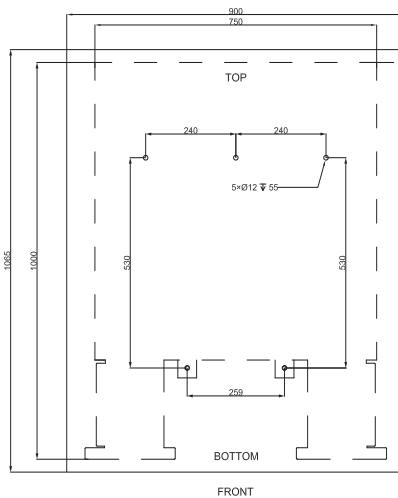

- (4) Using a Ø12 drill bit and hand drill to make holes for the M8 expansion screws at the marked positions (Note: the drilling depth is about 70mm).
- (5) Take out the black caps on the provided Mounting Bracket and use the provided M8 × 60 expansion screws to install the bracket on the wall and tighten it. Check the wall mounting bracket is horizontal with horizontal instrument

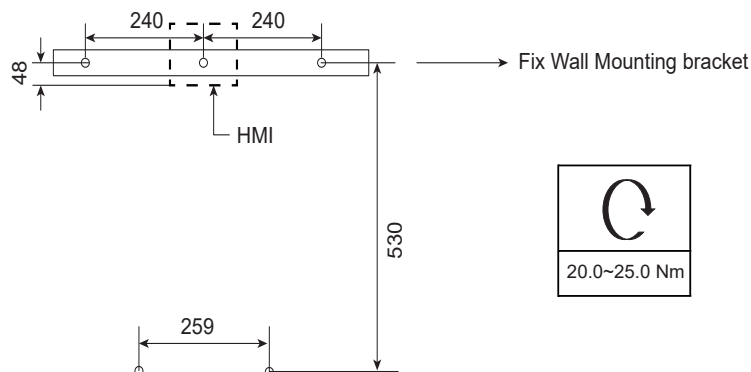

### 3.4 Ventilation Requirements

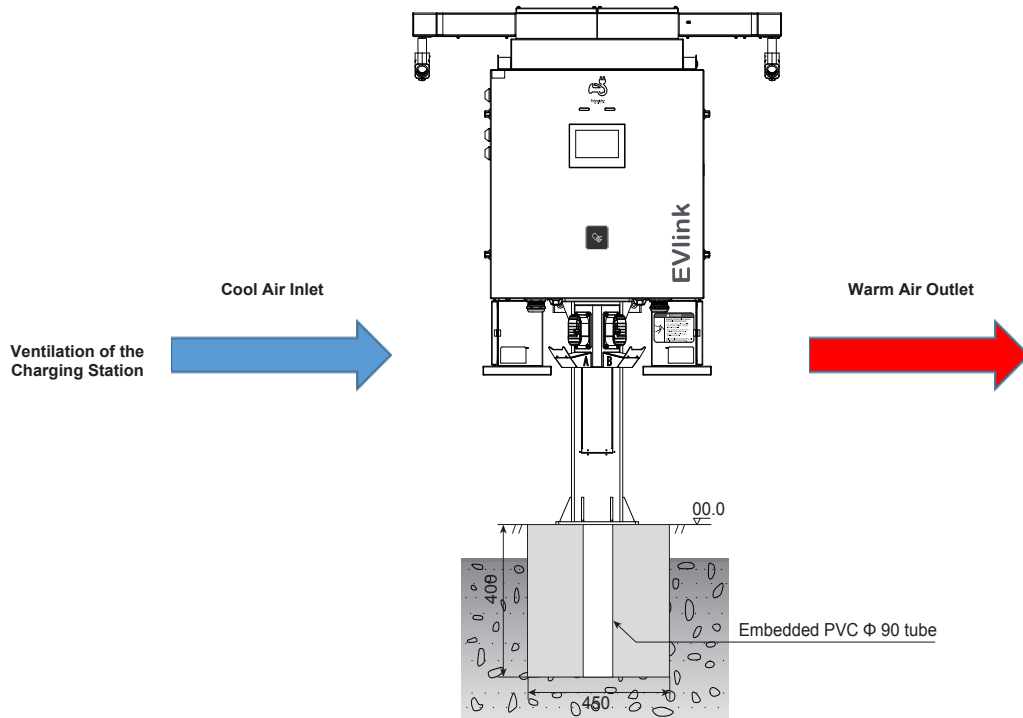

**Note:** If necessary, take precautions to prevent snow or objects from blocking the inlets, outlets or the operation of the cable management system.

### 3.5 Parking Place Arrangements Layout

It is possible to position the EVlink Pro DC 60 such that several parking spots can be served. But only two vehicle can be charged at a time.

Some possible arrangements of parking places in relation to the EVlink Pro DC 60 are shown in the figures that follow.

**NOTE:** The usable connector cable range with optional Cable Management System is 3.5 m.  
For other references the full length of the cable is usable providing extended range of 5m or 7 m.

■ The cover ranges of 5m charging cable with cable management:

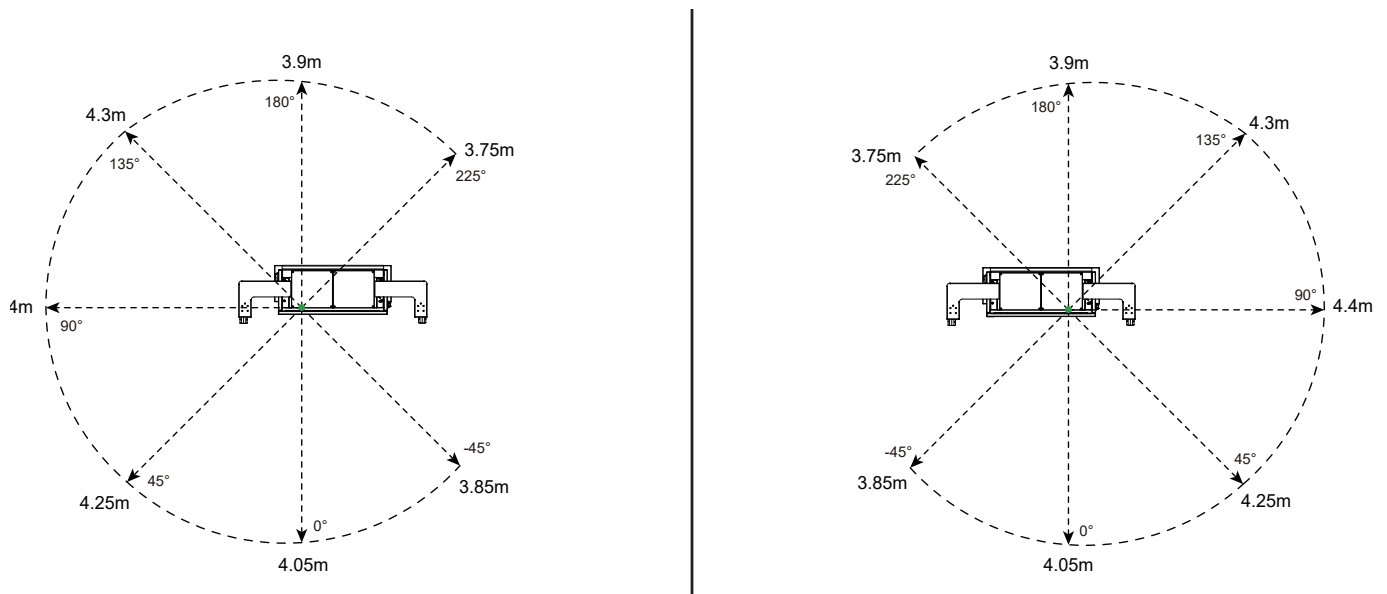

### 3.5 Parking Place Arrangements Layout

■ The cover ranges of 5m charging cable without cable management:

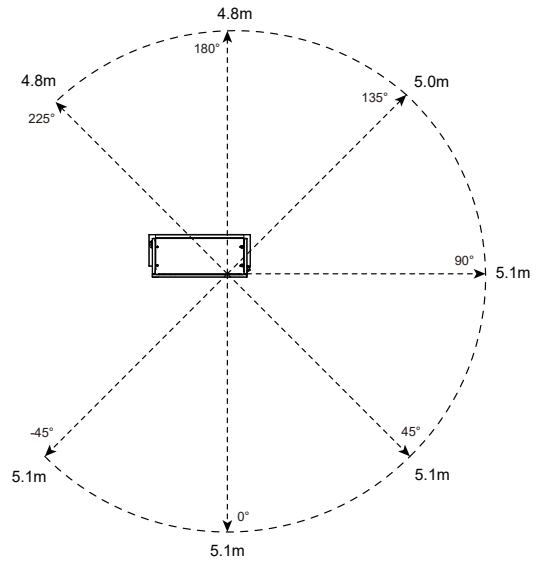
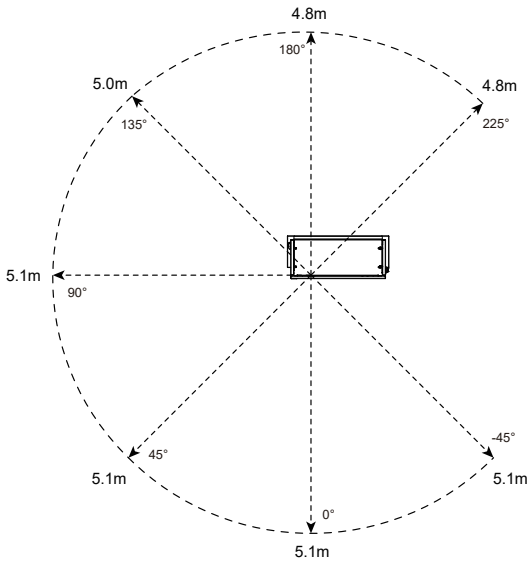

■ The cover ranges of 7.5m charging cable without cable management:

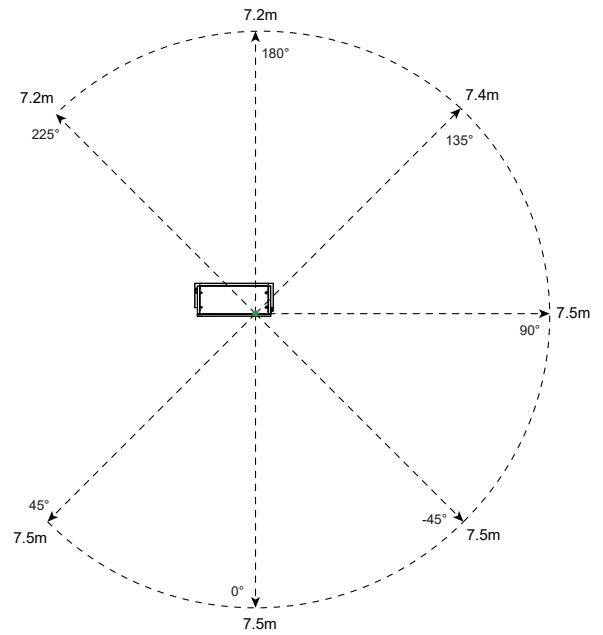
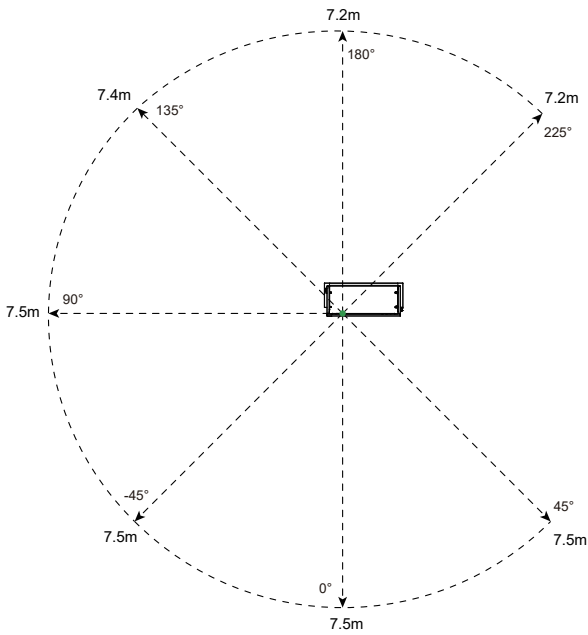

# 3

## Site Preparation

### 3.6 Signage and Location

Use road signs and / or special marking to direct drivers to the Charging Station locations and to distinguish the Electric Vehicle parking spaces from ICE (Internal Combustion Engine) vehicles spaces.

To provide a secure comfortable environment for users, and to prevent vandalism and / or theft:

- Install the Charging Station in a location where it can be clearly seen and / or monitored.
- Use 24/7 security control.
- Install sufficient lighting around the Charging Station.
- For a comfortable user experience it is recommended to install a shed or other protection from the direct sunlight while using the Charging Station.

### 3.7 Bollards

It is advised to place bollards around the Charging Station to protect against cars collisions.

**NOTE: Bollards limiting the access**

When installing bollards around the Charging Station make sure all doors can still be opened to be able to service the Charging Station.  
In case bollards are installed that are blocking the doors, make sure they are the removable kind.  
If removable bollards are used, ensure the tool/key required to remove them is available in case of the Charging Station requiring services.

### 3.8 Tilt / Collision Sensor

EVlink Pro DC 60 is equipped with a tilt sensor that will interrupt output power/charging session if the sensor detects a tilt in the cabinet in any direction, for example if a vehicle collides with the Charging Station.

If triggered the indicator light will turn RED and any ongoing charging session will stop. The relevant error message will be shown on screen and an error code will be relayed to the OCPP backend if connected.

# 4

## Electrical Requirements

### ⚠ WARNING

**RISK OF FIRE AND/OR EQUIPMENT DAMAGE**

- Ensure the appropriate circuit protection, and metering is in place at the installation site.
- Ensure that a grounding conductor that complies with local codes is properly grounded to earth at the power distribution equipment.
- Ensure that a correctly rated, dedicated breaker is installed for each station.
- Ensure that the cross section of the selected cable relates to the maximum current needed.
- In the event of irregularities or disturbances in the operation of the device press the emergency charge stop button and unplug your car.

**Failure to follow these instructions can result in death, serious injury, or equipment damage.**

The electrical requirements for each type of Charging Station shall be followed according to this table:

#### Electrical Parameters

Rated supply voltage	380 V – 415 Vac +/- 10 % 50 Hz
Earthing system	TT/TN-S / TN-C-S
Power factor	0.99 at nominal output power
Efficiency	95 % at nominal output power
THDi	≤5 % at nominal output power

#### Upstream Protection

Circuit breaker* *It is required to use circuit breaker with 30 mA residual current protection or in accordance to local regulations.	3PH + N + PE
Nominal output power	60 kW
Rated input current	96 A
Max input current	115 A

#### Upstream Cables

Suggested cable type	U1000 R2V Fine or Extra Fine Wire Strands
----------------------	---

#### Cable Entry\*\*

Maximum conductor cross section/phase	5x35mm <sup>2</sup>
Maximum outer cable diameter/phase	32mm

\*For additional flexibility in installations with different cable cross sections and/or number of cables per phase, EVlink Pro DC 60 is delivered with 2 different cable entry plates.

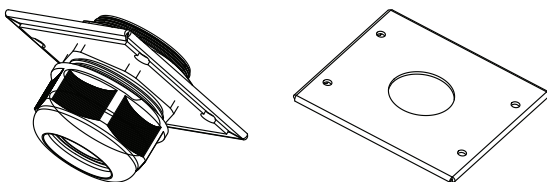

**NOTE:** The necessary cable size calculations need to be verified according to site conditions, cable route, length, voltag drop.  
Bimetallic lugs must be used in the case of Aluminum cables.

# 5 Communication

## 1. Cellular and wireless signal

Use a signal detection device to ensure the signal is within the recommended strength according to the below guidelines:

(Note that these numbers are negative, so -70 dBm is stronger than -85 dBm, and -90 dBm is weaker).

Signal Quality	Cellular Signal	CSQ
	Excellent	> 15
	Fair	2 to 15
	Poor	< 2

Signal Quality	Wireless LAN Signal (WIFI)	CSQ
	Excellent	> -70
	Fair	-70 to -90
	Poor	< -90

## 2. Ethernet cable

Use RJ45 cat 6, shielded, twisted pairs.

# 6 Required Materials and Tools

## 1. Specific equipment

Before you go to the site, please prepare the following tools/equipment:

- Forklift/Crane
- Step ladder
- Personal Protective Equipment (PPE)
- Cable cutter
- Wire stripper
- Wire presser/pliers
- Power drill
- Spirit level
- Toolbox
- Multimeter
- LOTO (Lock Out Tag Out) equipment

**NOTE:** The above tools should be selected according to the actual situation on-site.

# 7 Receiving, Handling

## 7.1 Receiving

### ⚠ DANGER

#### HAZARD OF HEAVY EQUIPMENT FALLING

Do not stand or move beneath the crate as it is being lifted or tilted.

**Failure to follow these instructions will result in death or serious injury.**

### ⚠ WARNING

#### HAZARD OF EQUIPMENT FALLING

- EVlink Pro DC Charging Stations are delivered on pallets, enabling the bottom handling.
- When handled from the bottom, the Charging Station must be lifted with care and held in place during transport by properly strapping them onto the forklift or handling equipment.
- Always transport and store the Charging Station in its original packaging.
- Ensure the load rating of all lifting equipment (forklift, crane and lifting straps, etc) is adequate for the weight of the Charging Station as shown below.

**Failure to follow these instructions can result in death, serious injury, or equipment damage.**

### ⚠ ⚠ DANGER

#### HAZARD OF ELECTRIC SHOCK, EXPLOSION, OR ARC FLASH

- Do not install the Charging Station during harsh weather.
- If you must complete the installation in rain or wind, you must use a weather-proof shelter that covers all boxes and components to avoid water entering inside the enclosure.
- Ensure upstream protection breaker is locked in the Open (OFF) position and a voltage absence test is performed before starting the installation.
- Do not use power tools during installation or servicing. Over-torquing can damage the equipment.

**Failure to follow these instructions will result in death, serious injury.**

## 7.2 Contents

- Inside the EVlink Pro DC Shipping box you should find the below mentioned items & documents.
- If there are any missing items or documents, please contact Schneider Electric for the necessary replacements:

Item	Quantity
EVlink Pro DC Charger 60	1
Power Modules	2
Cable Management System	Optional
Keys	6
Generic RFID badge (for testing)	2
M10X30 Screws	7
M8 Expansion Bolt	6
Vehicle connector Seat Assembly	2
Vehicle connector Holders for Wall mounted Model	2
Side Door Support	1
Installation Template	1
Safety labels in multiple languages	22

## Documents

Installation manual  
User guidance sticker

Each EVlink Pro DC 60 Charging Station ships in one crate. Ensure you have correct crate at the installation site.

Contents	Shipping dimensions (W*D*H)	Shipping weight (kg)
EVD1S60TBB	1100*1250*770mm	221
EVD1S60THB	1100*1250*770mm	221
EVD1S60TBBC5	1100*1250*770mm	187
EVD1S60THBC5	1100*1250*770mm	187
EVD1S60TBBC7	1100*1250*770mm	194.5
EVD1S60TBB-AN	1100*1250*770mm	221
EVD1S60THB-AN	1100*1250*770mm	221
EVD1S60TBBC7-AN	1100*1250*770mm	194.5
EVD1S60TBB-SA	1100*1250*770mm	221
EVP1DB3LG	480*520*920mm	27
EVP1DB4LG	480*520*1160mm	31
EVP1DB5LG	480*520*920mm	27
EVP1DB6LG	480*520*1160mm	31
EVA1D60S01	600*800*510mm	49

\*For more customized commercial reference, please contact Schneider Electric.

# 8

## Unpacking and Inspection

### 8.1 Unpacking

#### ⚠ CAUTION

##### HAZARD OF SHARP EDGES

It is recommended to wear protection gloves when unpacking the Charging Station as there could be sharp edges.  
**Failure to follow these instructions can result in injury.**

#### ⚠ CAUTION

##### HAZARD OF POTENTIAL LOOSE COMPONENTS INSIDE BOX

- At receiving always inspect the Tilt and Shock sensors on the crate for potential damage or mishandling.
  - If the sensors are triggered do not attempt to unpack, inform the transport agent and refuse reception.
- Failure to follow these instructions can result in death, serious injury, or equipment damage.**



#### ⚠ WARNING

##### RISK OF EQUIPMENT DAMAGE

- 2 operators and step ladders are required to safely unbox the EVlink Pro DC Charging Station.
  - The power modules are inside the shipping box so take caution while opening the side of the box.
  - The power modules should remain in their cartons until the Charging Station is installed in the final location.
- Failure to follow these instructions can result in death, serious injury, or equipment damage.**

#### Unpacking steps:

- Place the unpacked Charger shipping box close to the area where it will be installed.
- First remove the Top Cover of the wooden crate.
- Remove and keep the installation template.
- Proceed to removing the side panels of the crate.
- Carefully remove the Power Module crates and place in a safe and protected space.
- Carefully remove the Cable management (only for versions with Cable management) and the inner Foam protection profiles.
- Carefully remove the Vehicle connector and the inner Foam protection profiles
- Keep the Charger on the provided pallet after removing all the side panels.
- Carefully remove the plastic wrapping around the Charger and inspect the Charger for any scratches or damages.
- Remove the Charger from the bottom foam profile.

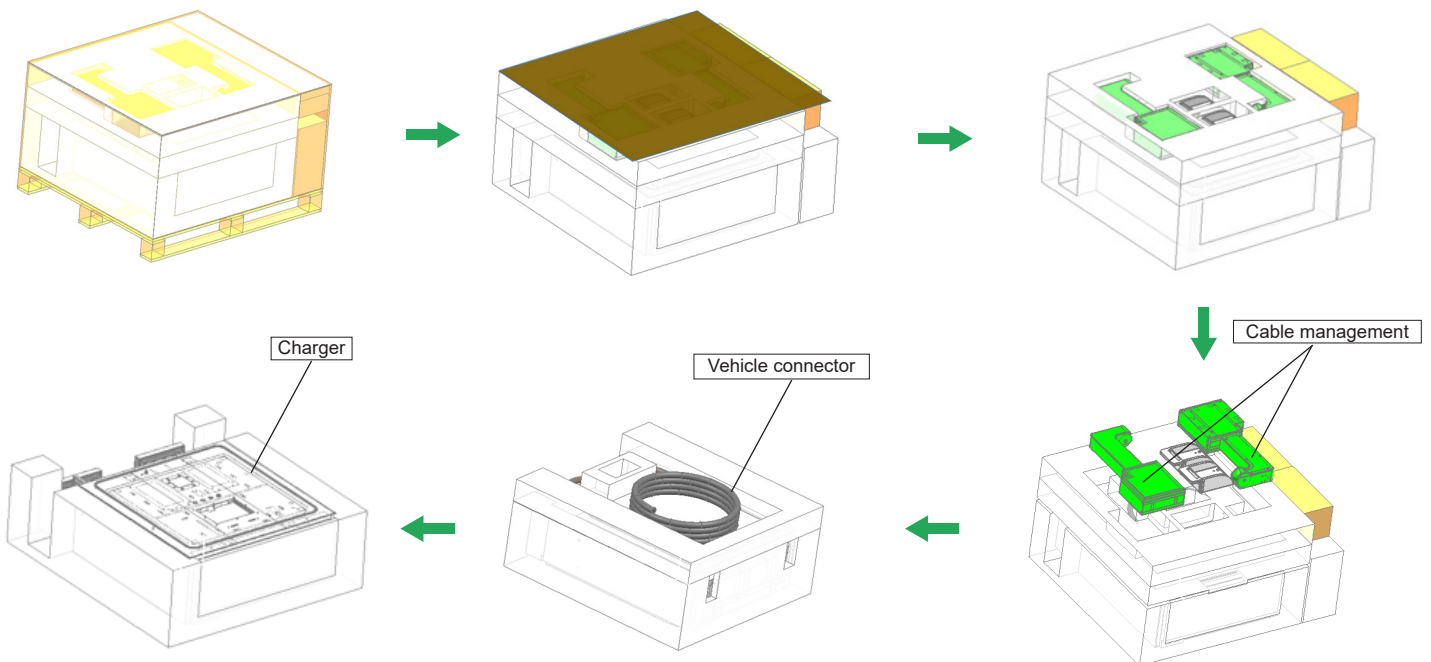

### 8.2 Inspection

#### After unpacking the EVlink Pro DC, the installer should check all the items below:

- Appearance: check whether the appearance of the Charging Station is damaged, whether there is any damage such as paint loss, scratch, deformation, and whether the structure of Charging Station is damaged during transportation.
- Labels: check whether the nameplate of Charging Station is correct, clear and complete, and whether the safety warning signs are posted in place.
- Contents: check whether the documents and accessories are complete according to the list of contents above.
- After inspection ensure the Charging Station is covered/protected from the weather.

## 9.1 Handling and Fixing in Place

**▲ WARNING****HAZARD OF HEAVY EQUIPMENT FALLING**

- The EVlink Pro DC 60 weighs at least 130 kg without power modules installed, ensure appropriate hoisting ropes and machinery.
- Extreme caution must be exercised while handling, lifting, or hoisting the Charging Station.
- Personal Protective Equipment required, hard hat, safety shoes, gloves.

**Failure to follow these instructions can result in death, serious injury, or equipment damage.**

**1. Before hoisting:**

- Place the Charger Pallet close to the installation site
- Attach firmly the hoisting ropes to the Charger Lugs while charger is still on the pallet
- Prepare and secure in place the manual hoist
- Ensure the Wall Bracket (If wall mounted) or Pedestal (If floor standing) are installed correctly
- Prepare to hoist the charger

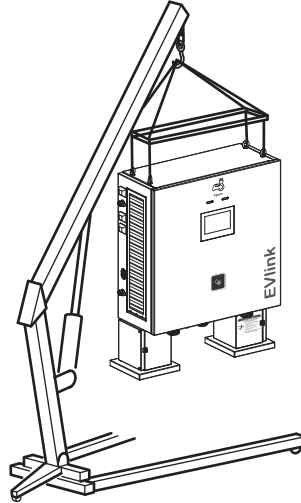

## 9.2 Wall mounted Installation

**STEPS:**

- Hoist the Charger with the Manual hoist slightly higher than the level of the mounting bracket.
- Carefully move the charger to the wall mounting bracket.
- For mounting bracket refer to 3.3 Wall installation Preparation steps.
- Maneuver the Bracket Pins into the Charger mounting holes on the back and ensure it is secured.
- Slightly lower the Manual hoist rope to test that the charger is correctly mounted on 3 bracket pins.
- Mount the lower part of the Charger using the provided M8 × 60 screws on the wall mounting holes.

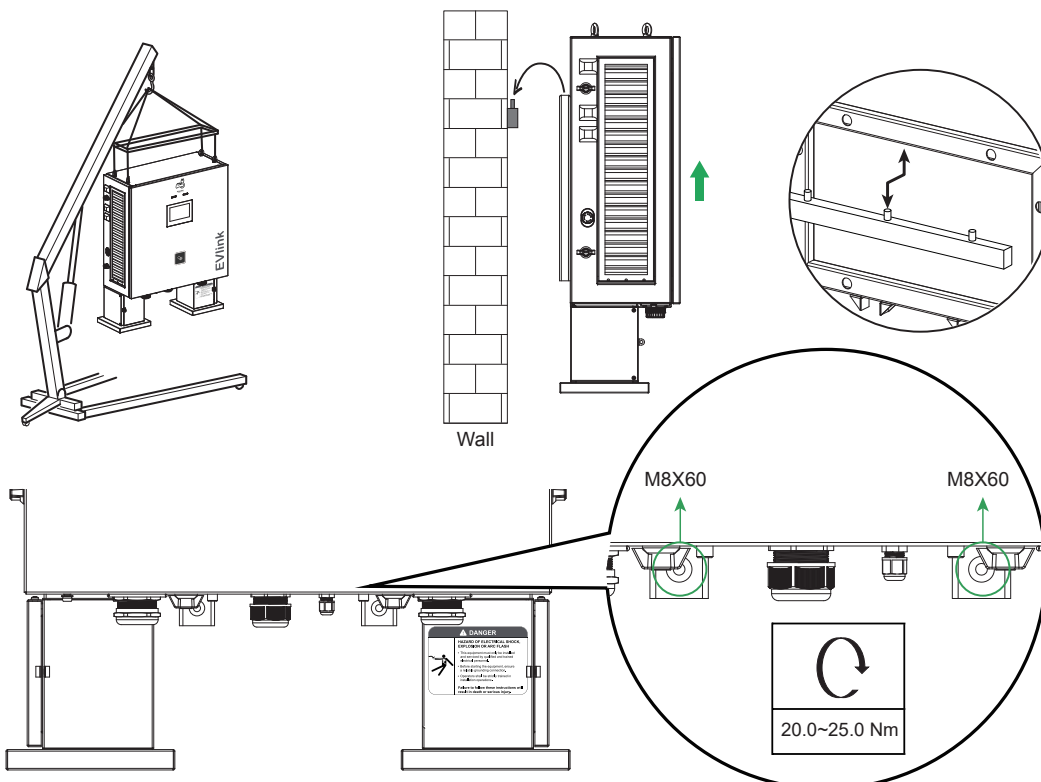

## 9.2 Wall mounted Installation

The EVlink Pro DC 60 is delivered with vehicle connector Holders.

The Connector Holder is installed on the adjacent wall if charger is Wall mounted. Use tool to ensure the horizontal & vertical position.

## STEPS:

1. Remove the four Black cover on the vehicle connector holder.
2. Select a suitable position on the wall and make sure it complies with local regulations and/or accessibility to disable people.
3. Mark the drilling position according to the four holes on the connector holder.

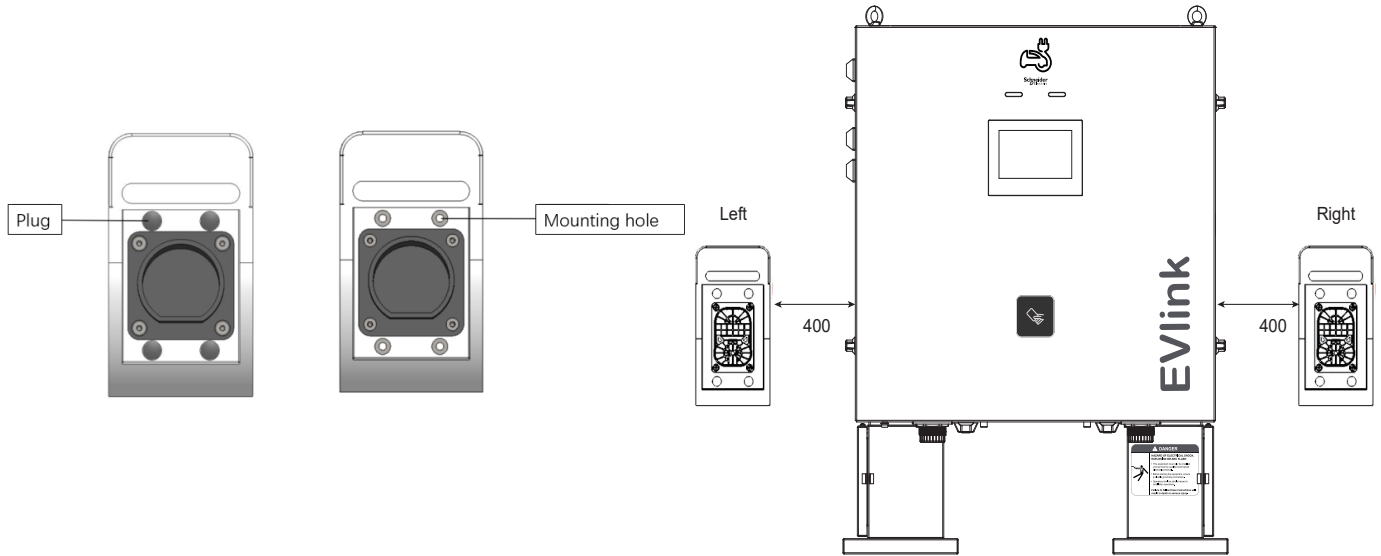

4. Use a  $\varnothing 8$  drill bit to drill holes with a depth of about 70mm at the marked position.
5. Drive M6  $\times$  60 expansion screws into the hole and fully tighten the 4 expansion screws.
6. After installing connector holders, restore the black plugs.

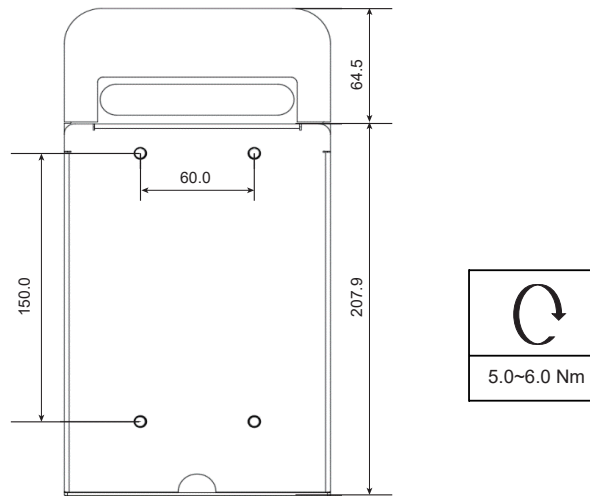

**Note:** CHAdeMo connector must be installed on the right.

## 9.3 Floor Standing Installation

**NOTICE****RISK OF DAMAGING**

- Ensure that the Power cables are stripped, and lugs are connected before attempting to mount the charger on the pedestal.
  - Ensure that the Ethernet cable (if required) is wired into the pedestal before attempting to mount the charger on the pedestal.
- Failure to follow these instructions can result in equipment damage.**

### 9.3 Floor Standing Installation

**STEPS:**

1. Place the pedestal onto the foundation and fix it by 8 embedded M14 anchor bolts (not included in shipping box) on the Concrete pad.

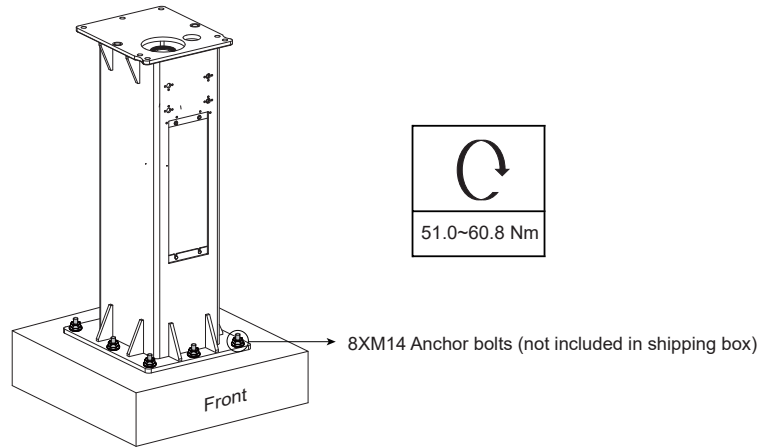

Remove the cover plate at the front of the pedestal.

### ⚠ ⚠ DANGER

**HAZARD OF ELECTRICAL SHOCK**

- Add a ground wire in the pedestal.
- Connect this ground wire to the pedestal earthing pin.

**Failure to follow these instructions will result in death, serious injury.**

2. Manually guide the power cable (and ethernet cable if applicable) rising from the concrete pad into the top opening of the pedestal at the Charger side. Add the earthing to the pedestal from the earthing pin. This step could be operated by opening the front cover plate of pedestal, and after then, please reinstall the cover plate.

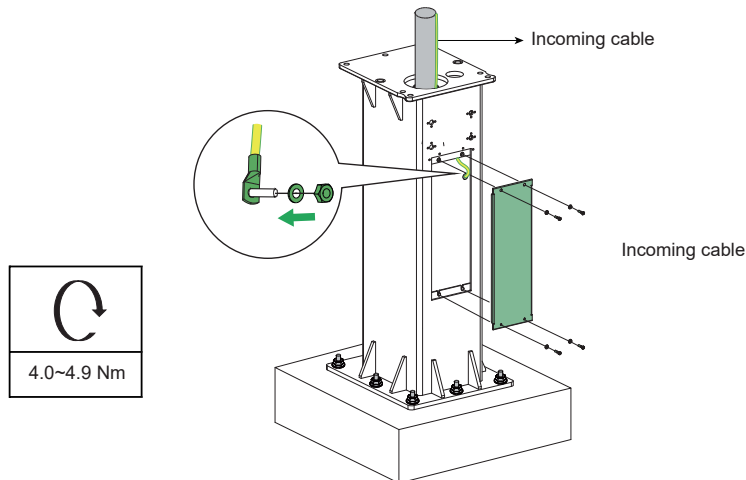

3. Lift the charger above the pedestal using the manual hoist.
4. Insert the top end of the cable through the Charger cable gland.
5. Align the screw holes between the pedestal & charger.
6. Securely fix the Charger on the pedestal with 7 screws of M10 × 30.

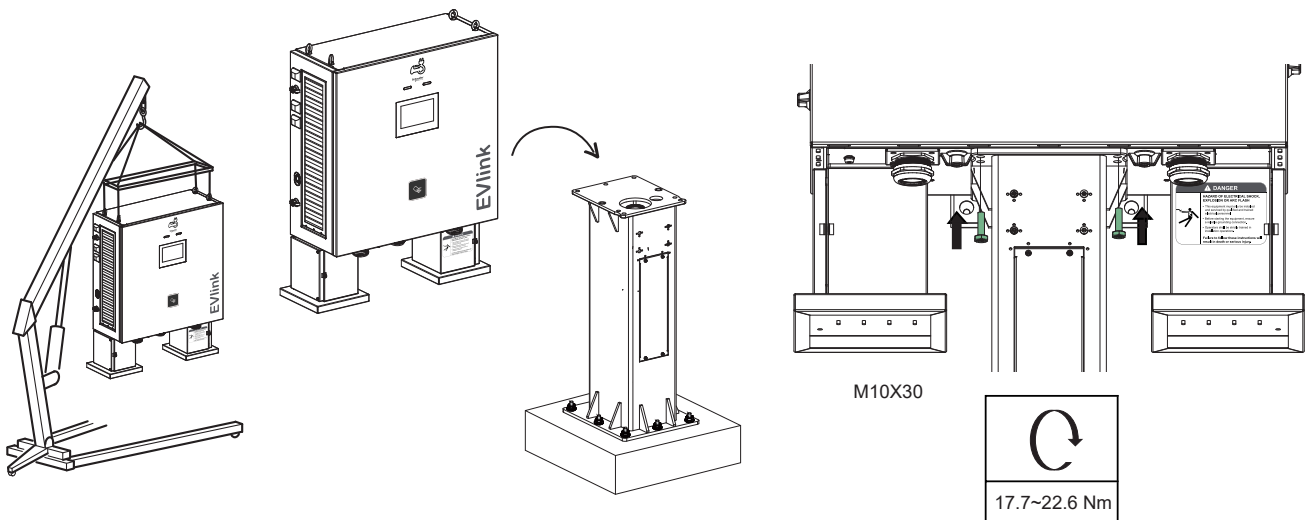

## 9.3 Floor Standing Installation

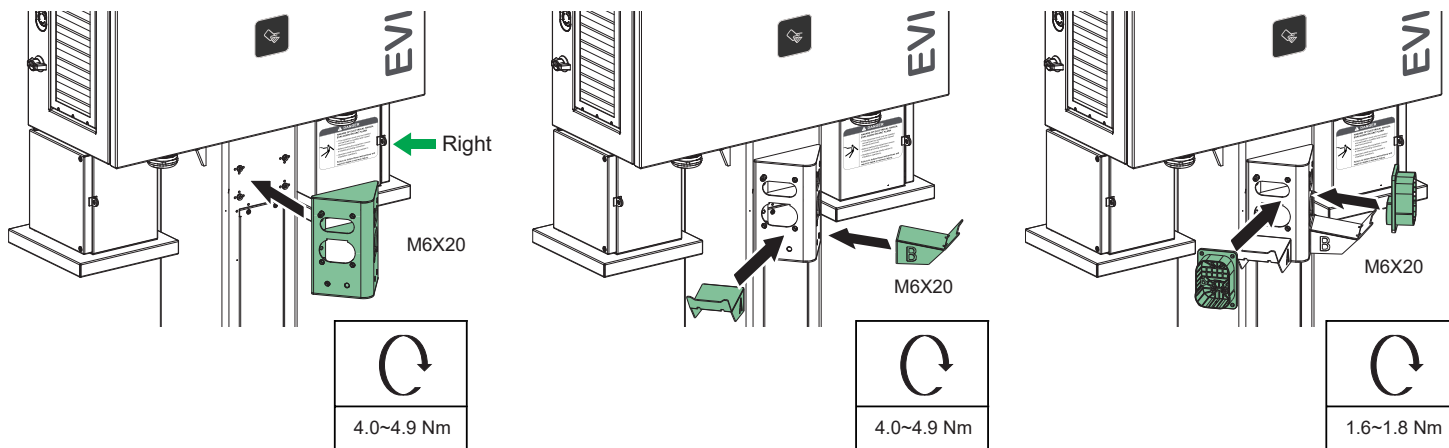

**Note:** CHAdeMo connector must be installed on the right.

## 10 Connecting

## ▲ WARNING

## HAZARD OF INVOLUNTARY DOOR DISENGAGEMENT

- Ensure the good insertion of the door support in his location.
  - Tighten the screw to avoid any involuntary disengagement of the door support from its location.
- Failure to follow these instructions can result in death, serious injury, or equipment damage.

## STEPS:

1. Open the front door from the bottom of the charging box, use the provided support to prop up the front door, as shown below.

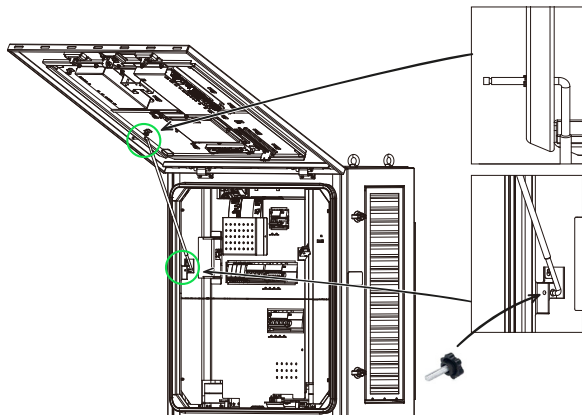

2. From the front of the Charger, unscrew the protective cover and set aside. It will be installed again after.

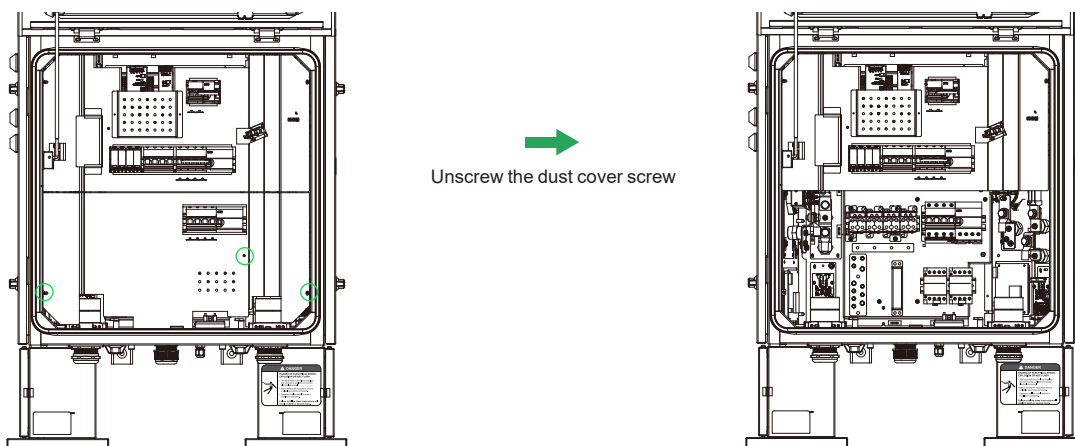

## ⚠ ⚠ DANGER

### HAZARD OF ELECTRIC SHOCK

- It is mandatory to make the PE wire longer than the phase wires to ensure that the PE wire stays connected the longest if the charging Station is moved by an accident collision.
  - Always connect the protective earth first, before connecting the N and phase wiring.
- Failure to follow these instructions will result in death or serious injury.**

3. Connect the PE Cable lug to the PE copper bar and tighten to 11Nm.
4. Connect the 3 Phase and Neutral Cables to their corresponding terminals and tighten referring to the table below.

Cable type	Cable section	tightening torque	stripping length
Copper	35 mm <sup>2</sup>	10 Nm	19 mm
Aluminum	35 mm <sup>2</sup>	13.6 Nm	19 mm

Note: Maximum outer cable diameter/phase:32mm

1. When ethernet cable is not used, its cable gland can be used to earth connection (wire) between the pedestal and the charger.
2. If ethernet cable is present, cable gland is not available. It's mandatory to add an additional earth wiring between the pedestal (stud inside pedestal) and the charger earthing plate.
3. Need to consider the protection of power cable and make sure it comply with local regulations.

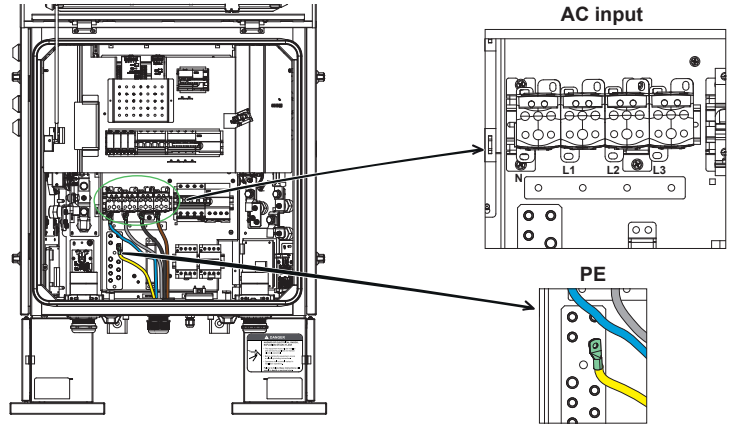

### 10.1 Ethernet Connection (Optional)

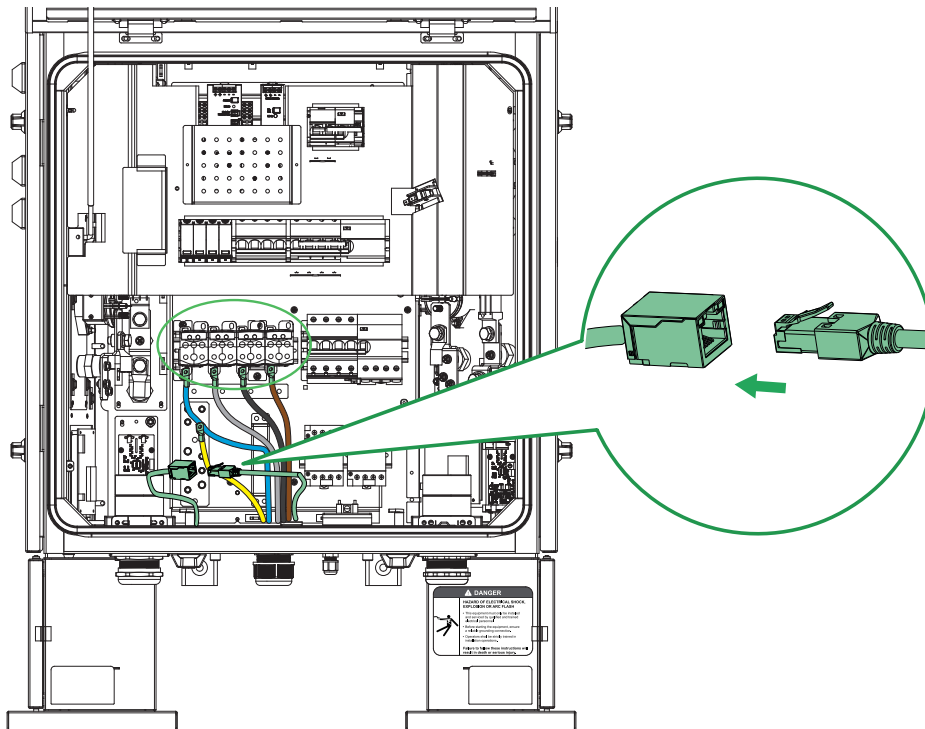

## 10.2 Installation of 4G SIM Card (Optional)

### 1. 4G SIM Card for EcoStruxure Energy Asset Portal connectivity

**NOTE:**

- If the Connectivity to Ecostruxure Energy Asset Portal is needed, 4G SIM Card must be installed.
- The SIM Card slot is able to receive a Mini 25 mm SIM Card only.
- The 4G SIM Card is provided by Schneider.

- A** • Locate the Communication board as shown in the image.
- B** • Carefully insert the SIM Card in the dedicated slot as shown in the image.
- C** • To remove the SIM Card, pull it out from the slot.

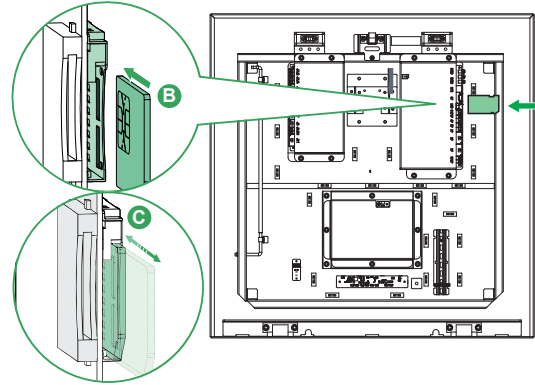
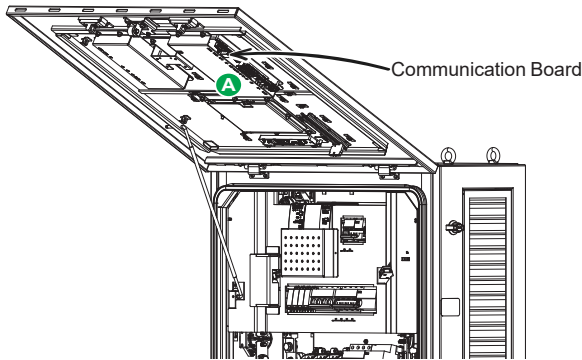

### 2. 4G SIM Card for CPO connectivity

**NOTE:**

- If the CPO connectivity is 4G, 4G SIM Card should be installed.
- The SIM Card slot is able to receive a Mini 25 mm SIM Card only.
- The 4G SIM Card is provided by customer.

- A** • Locate the meter & router compartment on charger's lower right.
- B** • Unscrew the 2 anti-theft screws on the meter compartment (use T20 bit) with torque (N·m): 1-1.4.
- C** • Carefully store these 2 anti-theft screws.
- D** • Open the compartment's door and locate the router.
- E** • Push the yellow dot (diameter approx. 2 mm) as shown in below picture with a paperclip's tip. SIMCARD carrier will pop out.
- F** • Place the SIMCARD into the carrier as shown in below pic.
- G** • Push the carrier back into the "SIM" slot in the router.
- H** • Close the compartment's door and screw back the 2 screws (with T20 bit) with torque (N·m): 1-1.4.

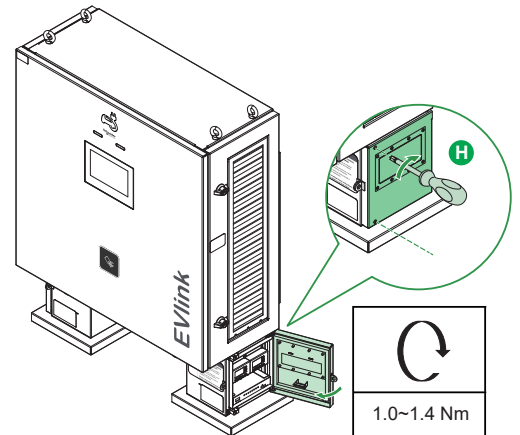
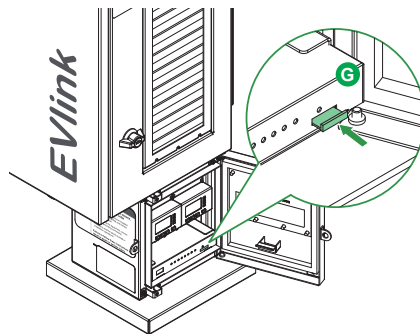
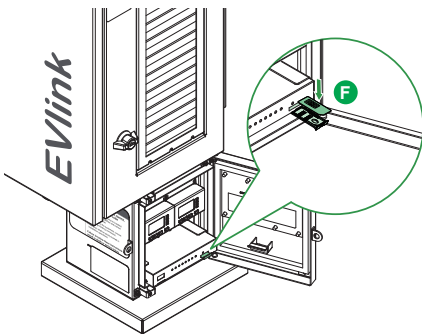
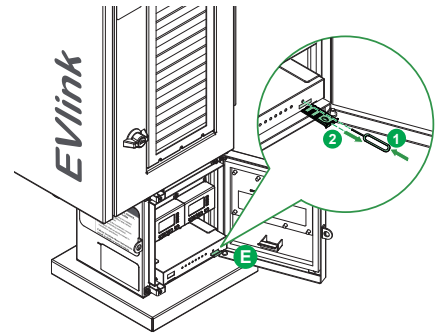
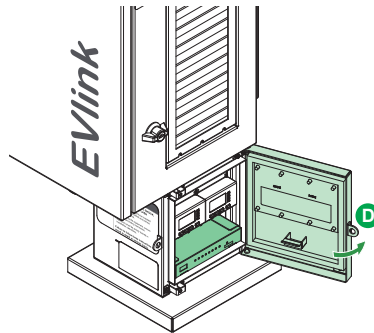
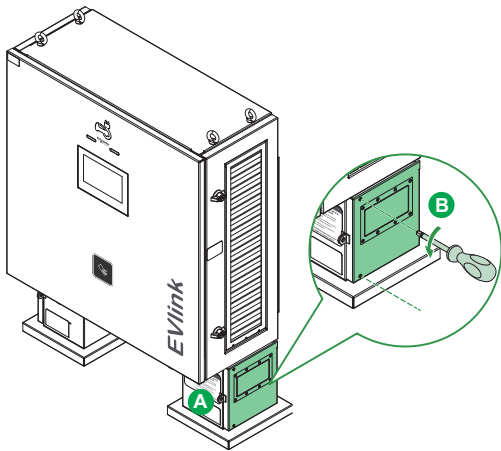

### 10.3 After connection

- Ensure all wiring is firmly connected.
- Complete the check list related to connection.
- Fix the cover back in place.
- Close and lock the door.

# 11 Installation of Power Module

## ⚠ CAUTION

### HAZARD OF EQUIPMENT DAMAGE

- The front and rear of the power module must be clear of any obstructions while installed in the Charging Station.
- Failure to follow these instructions can result in equipment damage.**

The physical appearance of the Power Module is shown here below:

### NOTE:

The power modules are shipped with their address settings set and identified in their addressed order from top to bottom; i.e. A01 in the top slot and A02 in the bottom slot. The power modules **must be** inserted into the slot in the correct direction as shown below.

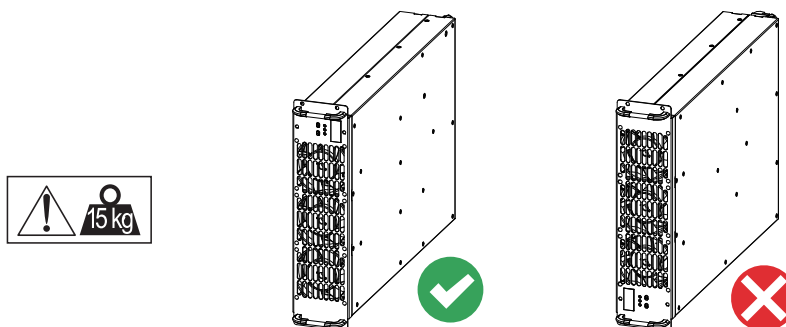

1. Open the Left-hand door of the Charger and use the provided side door support to prop up the Left-hand door, as shown below.
2. Locate the Slot in which the Power module will be installed.
3. Carefully with 2 hands hold the Power module using both handles and insert in the available slot.
4. Use the 4 provided screws to fix the Power Module in place
5. Close and lock the door

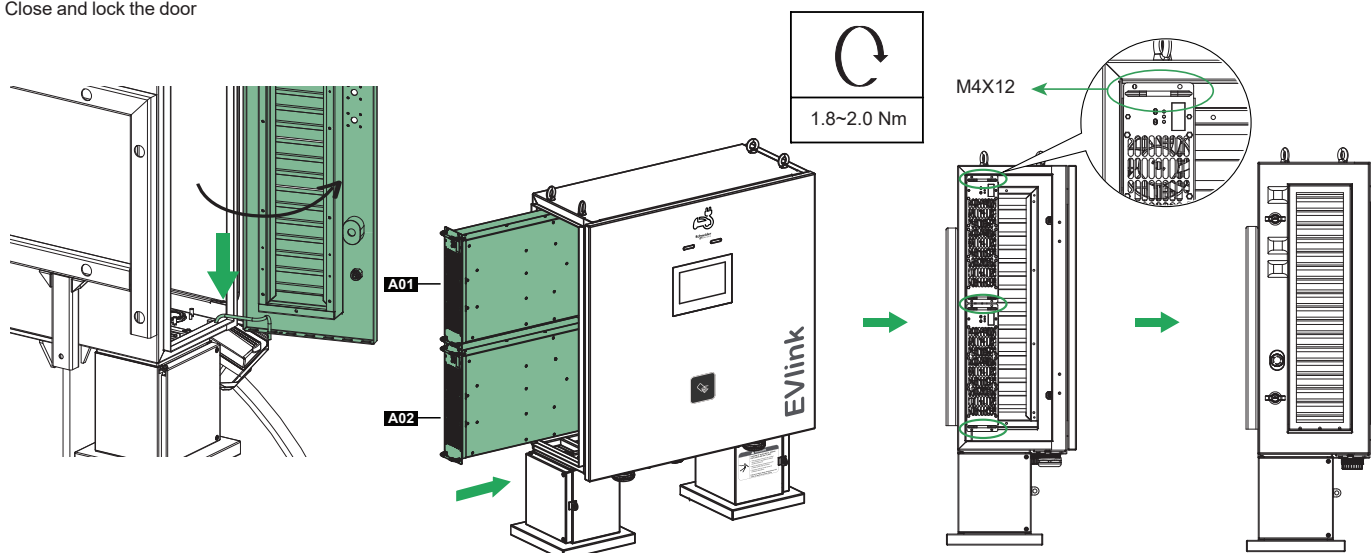

# 12 Cable Management

## 12.1 Cable Management System Installation (Optional)

## ⚠ WARNING

### HAZARD OF HEAVY EQUIPMENT FALLING

- Ensure appropriate hoisting ropes and machinery, the cable management system weight about 31kg.
  - Extreme caution must be exercised while handling, lifting or hoisting the cable management system.
  - Personal Protective Equipment required, hard hat, safety shoes, gloves.
- Failure to follow these instructions can result serious injury, or equipment damage.**

1. Remove the hoisting rings on the top of the charger main body as shown.

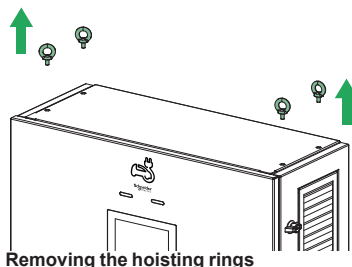

## 12.1 Cable Management System Installation (Optional)

2. Install the cable management system on the adapter plate, and fasten the cable management system with the screws on the back of the adapter plate as shown.

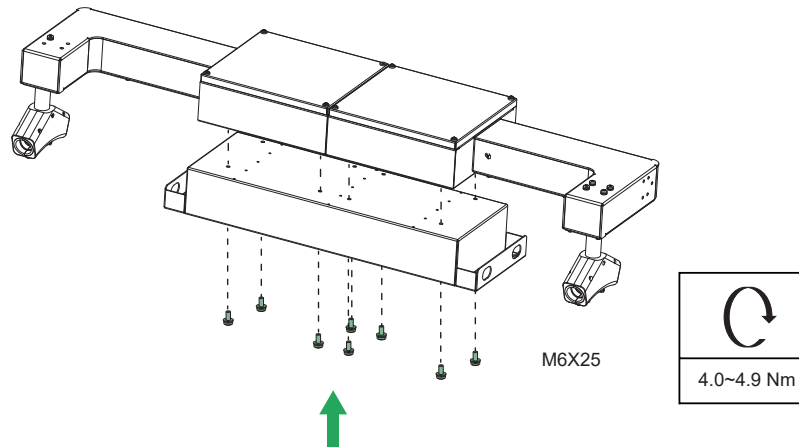

**Installing the Cable Management System on the adapter plat**

3. Hoist the cable management system, move it onto the top of the charger main body as shown.

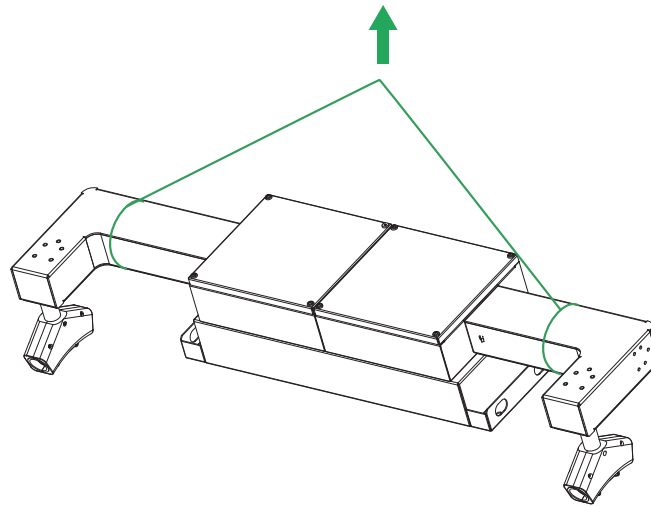

**Moving the cable management system onto the charger main body**

4. Align both sides of the adapter plate with both sides of the charger, and align the mounting holes.

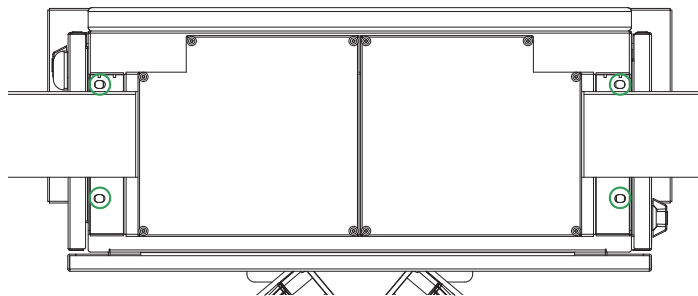

**Mounting the cable management system on top of the charger main body**

## 12.1 Cable Management System Installation (Optional)

5. Fix the adapter plate and the charger main body with screws.

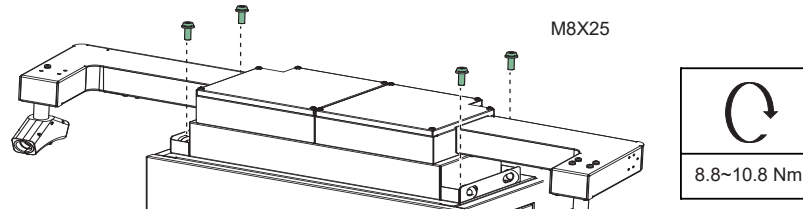

Fixing the adapter plate and the charger main body

6. The completed effect diagram is shown.

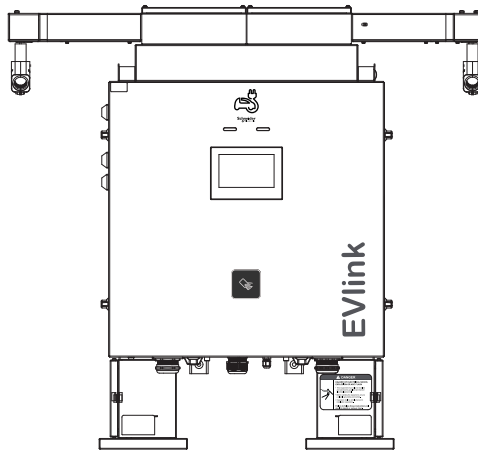

Effect drawing of cable management system installation

7. Remove 5 screws of M4× 25 from holder of cable management

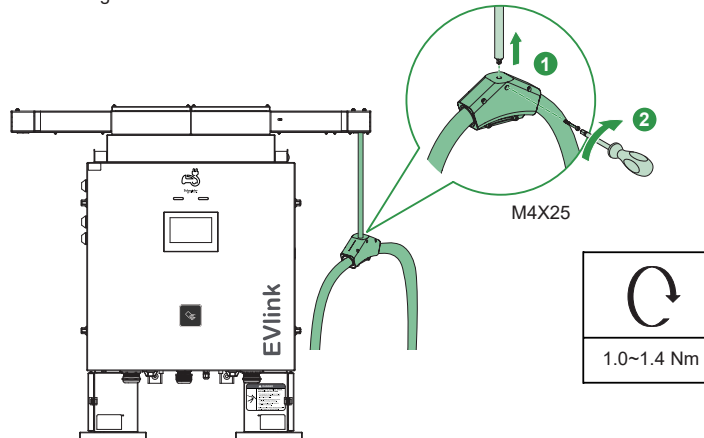

8. Fix the charging cable.

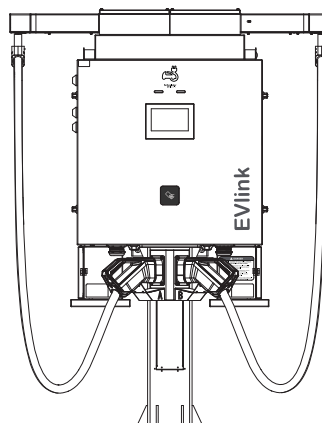

# 13 Finalization

- Complete the installation checklist (Appendix 1) and ensure any open points are closed before placing it in the document holder inside the charger for verification prior to commissioning.
- Place the provided user guidance sticker on a suitable/visible location on the Charging station. (Optional).

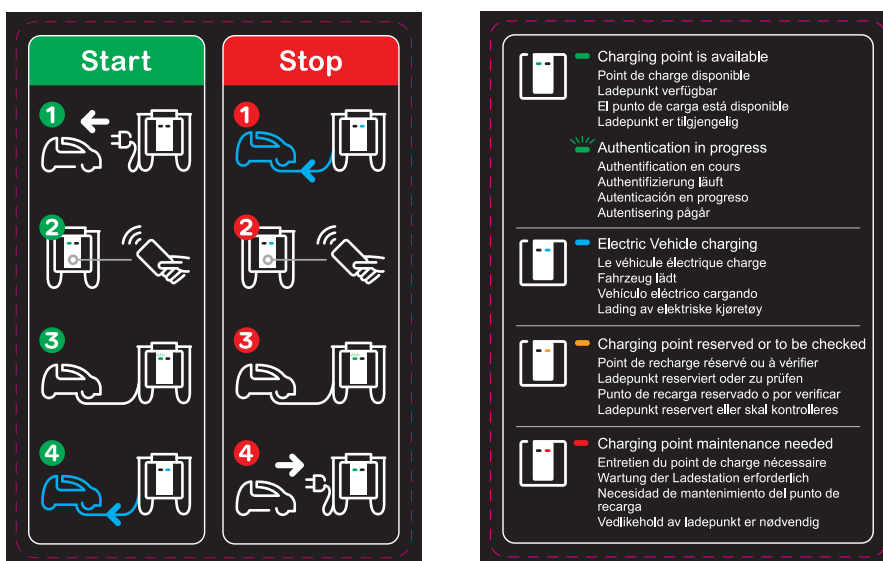

- In addition to the existing English safety label, safety labels in other languages are also provided. Following the illustration to place the label in desired language on the Charging Station. (Optional)

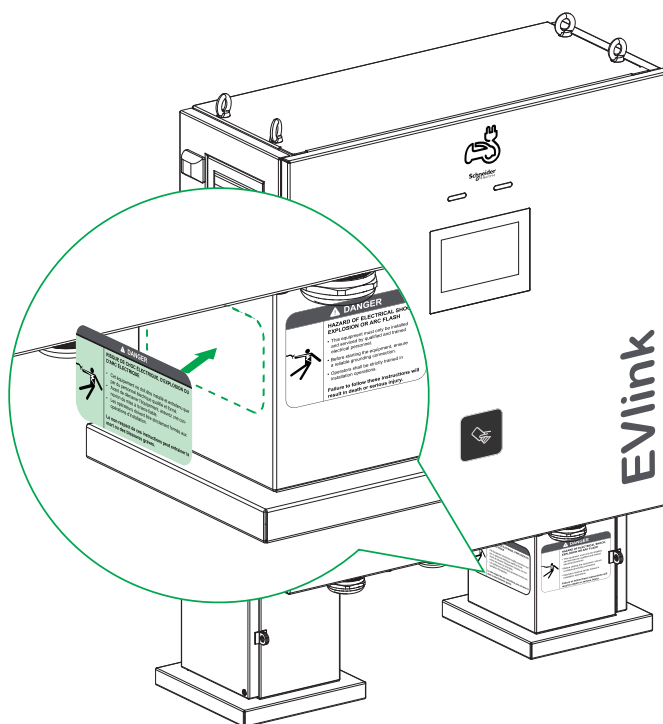

# 14 Startup / Shutdown

## ⚠ ⚠ DANGER

### HAZARD OF ELECTRIC SHOCK, EXPLOSION OR ARC FLASH

- When the system is in an open or dangerous condition, do not allow unqualified persons to go near it. Instruct/warn people about the potential harmful high voltages.
  - Make sure that the main upstream protection switch off the power supply for the product is set to the OFF position.
  - Follow standard Lock-OUT/Tag-Out before proceed.
  - Always perform a voltage absence test and make sure that the electrical power is disconnected from the system.
- Failure to follow these instructions will result in death or serious injury.**

# 14 Startup / Shutdown

## 14.1 Startup

After completing the installation inspection checklist, you can proceed to Startup the charger to test the Power system:

- A** • Keep the upstream circuit breaker in the OFF position and proceed to switch ON the QF1, QF2, QF3 and QF4 MCBs in the Charging Station.
- B** • Close and secure all the Charging Station doors.
- C** • Proceed to switch ON the upstream circuit breaker.
- D** • Wait for 1 minute for the HMI and indicator lights to come on-line. The HMI screen will display a welcome screen. Verify that there is no error message and that both indicator lights are stable green.
- E** • If you would like to proceed with commissioning operation next, please refer to the commissioning guide.  
Before then, you must follow the steps in the next section to shut down the charger and wait five minutes after shutdown to ensure there is no risk of electric shock.

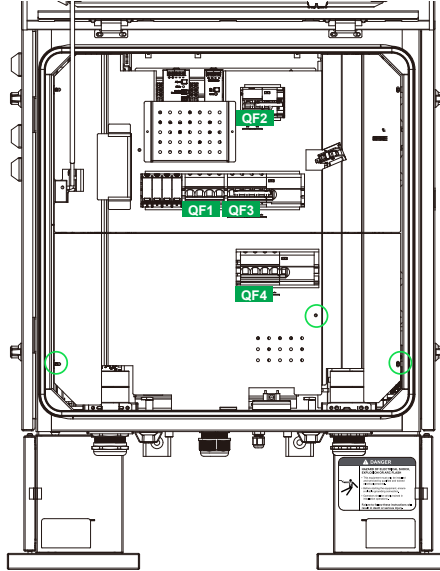

## 14.2 Shutdown

### ⚠️ DANGER

#### HAZARD OF ELECTRIC SHOCK

- Wait 5 minutes after the internal circuit breaker is switched off to discharge the stored energy remained in the Charging Station.
  - Perform absence of voltage verification using a voltage absence tester (VAT) before touching any internal parts.
- Failure to follow these instructions will result in death or serious injury.**

#### To shutdown the system:

- A** • Open the front door(refer to section 10).
- B** • Switch off the QF3 and QF4 MCBs.
- C** • Switch off the QF2 MCB.
- D** • Switch off the upstream protection breaker.
- E** • Perform Lock-out Tag-Out.

# 15 Hide Emergency charge stop button (Optional)

If the emergency charge stop function is not required, peel off the protective film from the adhesive back of the emergency charge stop cover plate, attach it over the emergency charge stop button and its markings. Before attachment, clean the surface with alcohol or an appropriate solvent to remove any oil or dust. Press evenly during attachment to ensure a secure bond.

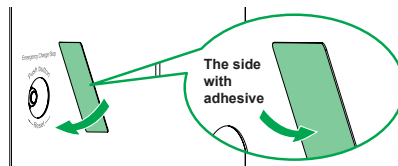

# 16 Recycle



#### Product Disposal

To comply with Directive 2012/19/EU of the European Parliament and of the Council of 4 July 2012 on waste electrical and electronic equipment (WEEE), devices marked with this symbol may not be disposed of as part of unsorted domestic waste inside the European Union. Enquire with local authorities regarding proper disposal. Product and packaging materials are recyclable as marked.

## Appendix 1: Installation Review Checklist

During the review, the engineer must record and report any problems which may be found.  
Any remarks or needed repairs must be completed and verified prior to energizing the equipment.

Inspection or Verification	Characteristics	Remarks or Repairs
<b>Structure</b>	Check whether the Charger cable glands are fixed and sealed.	
	Check the Charger is well mounted on the Wall/Concrete foundation and is leveled.	
	Check whether all doors operation and panels are intact, closed & locks are intact.	
	Check that the IP is maintained, gaskets & cable glands secured & no openings permit Dust, Insects or Rodents.	
	Check the necessary space is available for maintenance and all construction work is complete	
<b>Aesthetic</b>	Check the appearance and cleanliness.	
	Check all Signs & Notices are clear & intact & nameplate matches the charger performance.	
<b>Electrical Tests</b>	Grounding resistance is $\leq 4\Omega$	
	Check Clearances and creepage distances.	
	Check for Over/Under Voltage	
<b>Internal Components</b>	Verify the QF1~ QF4 MCBs are in the open (OFF).Position before energizing.	
	Check whether the internal components of the charger are intact. (Removal of internal covers is not required).	
	Visually check for any loose component or wiring.	
	Check for any loose hardware or foreign objects in the bottom of the charger.	
	Verify all grounding cables are secured on all doors and on the bottom of the charger.	
	Verify each power module is screwed in place in its correctly numbered slot.	
<b>Power Connections</b>	The specifications of the cables used meet the power requirements of the charger.	
	All connections are securely torqued according to the recommended values.	
	Phase orientation is correct and identified on the cables.	
	Check clearances and creepage distances.	
	Check the end plug-in(AC input & DC output)in the right door after inserting the power modules.	
	No breakage, damage, scratches on cable insulation & all electrical connections and wiring are correct and complete.	
<b>Communication</b>	Check the Charging Cable and Connectors are Intact.	
	Ensure that the 4G SIMcard is installed.	
	Ensure that the Ethernet cable is connected to the RJ45 port.	

Verified by:

**NOTE:** Complete the installation checklist and ensure any open points are closed before placing it in the document holder inside the charger for verification prior to commissioning.

## Appendix 2: Charging Station Mounting Template

### For Wall Mounting

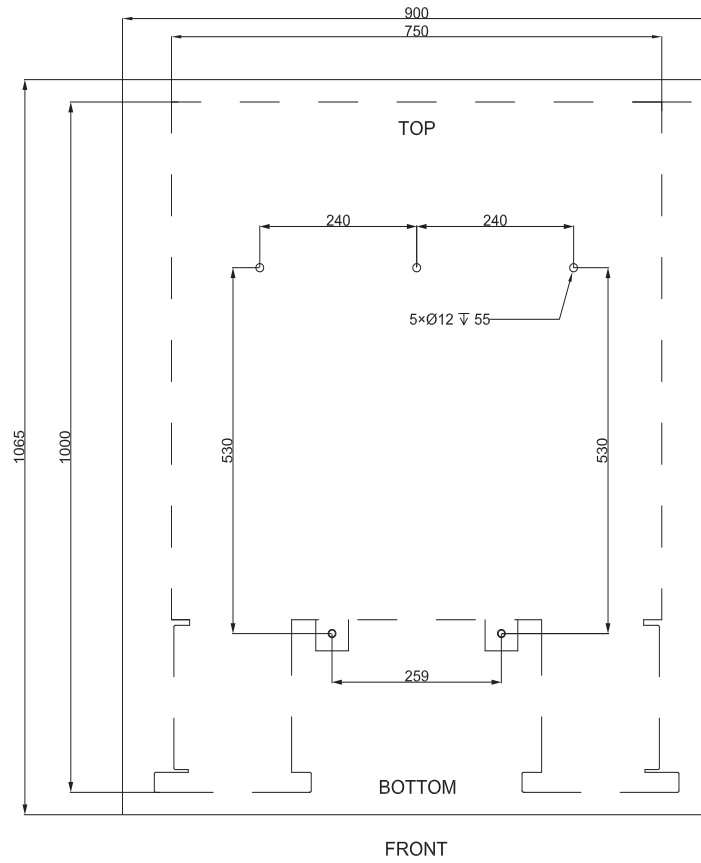

### Floor Standing

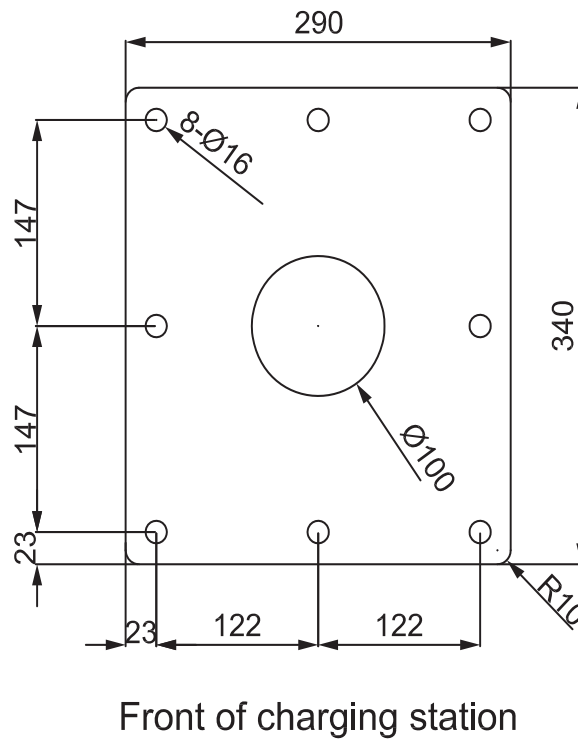

# Appendix 3: Schematic Diagram

