

SpaceLogic Sensors

SHD2 Series Duct Humidity Sensors – Analog



Product Description

SpaceLogic SHD2 Series Humidity Transmitters provide an ideal solution for measuring relative humidity in a wide range of conditions. All models are equipped with a solid state capacitive humidity sensor that is easy to replace in the field and a solid state temperature sensor for high accuracy measurements.

SHD2 is an all-in-one device combining humidity and temperature sensing. Intended for duct mount applications, the device ensures a building’s optimum temperature and humidity levels, resulting in greater energy efficiency.

Each device is an active sensor that converts a humidity or temperature measurement into 4-20 mA, 0 to 5 Vdc or 0 to 10 Vdc analog output.

Different models are available based on application requirements for lower-cost installations.

Features

- Easy to install:
 - Latch-on sensor cover
 - Screwless terminal block wiring with spring actuator
 - Mounting accessory adjusts probe length in duct
- Quick to commission with DIP switch selectable Voltage/Current mode
- 1% or 2% with NIST certificate, 2% RH module – field replaceable
- All passive temperature thermistor sensors include a 1-point measurement for offset correction
- Solid state temperature sensor providing high accuracy measurements
- Multiple temperature thermistors and transmitter options, compatible with a wide range of controllers
- 2-point calibration certificate available for humidity and temperature or temperature-only replaceable module
- Key component for the LEED green building program and WELL Building Standard*

*Leadership in Energy and Environmental Design (LEED) is a registered trademark of the US Green Building Council. The WELL Building Standard is a trademark of the International WELL Building Institute in the United States and other countries.

Available Products

SHD2	User Interface <input type="checkbox"/> X	Output <input type="checkbox"/> A	RH Accuracy <input type="checkbox"/> 2	Temperature <input type="checkbox"/>
	X = None	A = Analog output	2 = 2%	A = Transmitter only C = 1000 PT RTD H = 10K T3 thermistor

Example:

SHD2 X A 2 A

Note: Replaceable RH and temperature modules available to be ordered separately per table on page 2.

USA: +1 888-444-1311
 Europe: +46 10 478 2000
 Asia: +65 6484 7877
www.schneider-electric.com

Life Is On



Replaceable RH Elements & Temperature and Humidity Calibration Modules

Model	Description	Temp. Calibration	RH Calibration
SLXRHS2N*	Replaceable RH sensor, 2% with NIST certificate	N/A	2-point calibration
SLXRHS2X	Replaceable RH sensor, 2%	N/A	2-point calibration
SLXRHS1N	Replaceable RH sensor, 1% with NIST certificate	N/A	2-point calibration
SLXXT2**	Replaceable temperature module with 2-point calibration certificate	2-point calibration	N/A
SLXRHT2**	Replaceable temperature and humidity module with 2-point calibration certificate	2-point calibration	2-point calibration

*Not for use with SHO2 Series outdoor humidity sensors.

**For use on temperature transmitter models only.

Note: For instructions on installing replaceable elements, see Z208536-0x, *Replacement Humidity and Temperature Sensors Installation Guide*.

NOTICE

INACCURATE READINGS

- Avoid swapping the sensing element (located in the probe tip) between SCD2, SHD2 and SHO2 Series units.

Failure to follow this instruction can lead to inaccurate readings and/or unexpected outputs.

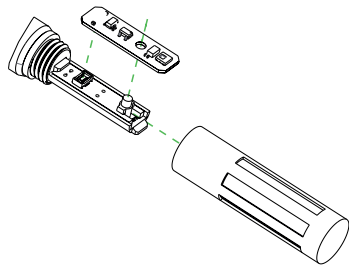

Specifications

Operating and Storage Environment	
Operating temperature	-35 to 60 °C (-31 to 140 °F)
Operating humidity*	0 to 95% RH (non-condensing)
Storage temperature	-35 to 70 °C (-31 to 158 °F)
Storage humidity	0 to 95% RH (non-condensing)
Power supply	3-wire volt mode: 20 to 30 Vdc, 24 Vac, 50 to 60 Hz; loop powered 20 to 30 Vdc
Output	Selectable 4 to 20 mA, 0 to 5 Vdc, 0 to 10 Vdc
Power consumption	See Maximum Power Consumption table, page 5
Output load	Voltage mode ≥ 5K Ohms Current mode ≤ 250 Ohms
Tube length	200 mm

Medium	Neutral gas, air
Housing material	Polycarbonate; Flammability rating UL 94 V0
Mounting location	For indoor use only. Not suitable for wet locations.
IP rating	IP 65
Protection class	Class III

Humidity Sensor	
Sensor type	Solid state capacitive, replaceable
Accuracy**	±2% from 10 to 80% RH @ 25 °C (77 °F) ±1%, ±2% NIST and 2% replaceable option
Hysteresis	1.5% typical
Linearity	Included in accuracy specification
Stability	±1% @ 20°C (68 °F) annually for 2 years
Output range	0 to 100% RH
Temperature coefficient	±0.1% RH/°C above or below 25 °C (77 °F) typical

Temperature Sensor	
Sensor type	Solid state, integrated circuit
Temp. sensing element	10K T3 thermistor, 1000 PT RTD
Time constant	Air velocity 1.5 m/s. approx. 72 s; Air velocity 3.0 m/s. approx. 52 s
Accuracy***	±0.2 °C (±0.4 °F) typical at 25 °C
Resolution	0.1 °C (0.1 °F)
Range	-35 to 60 °C (-31 to 140 °F)

Wiring Terminals	
Wiring	Screwless terminal block with spring actuator, 16-24 AWG

Warranty	
Limited warranty	2 years

Regulatory Information	
Agency approvals	UL 916 European conformance CE: EN 60730-1, EN 61000-6-2, EN 61000-6-3, EN 61000 Series - Industrial Immunity, EN 61326-1 FCC Part 15 Class A Green Premium (REACH, RoHS), RoHS 2 (China), RCM (Australia), ICES-001 (Canada), UKCA (UK)

*Duct mount model with temperature and humidity only.

**Humidity sensor measurement uncertainty should include: accuracy, hysteresis, temperature coefficient and stability. Humidity accuracy up to -20°C.

***±0.5 °C accuracy from 0 to 60°C, ±1°C accuracy from -35 to 0°C.

USA: +1 888-444-1311
Europe: +46 10 478 2000
Asia: +65 6484 7877
www.schneider-electric.com

Life Is On



Dimensions mm (in.)

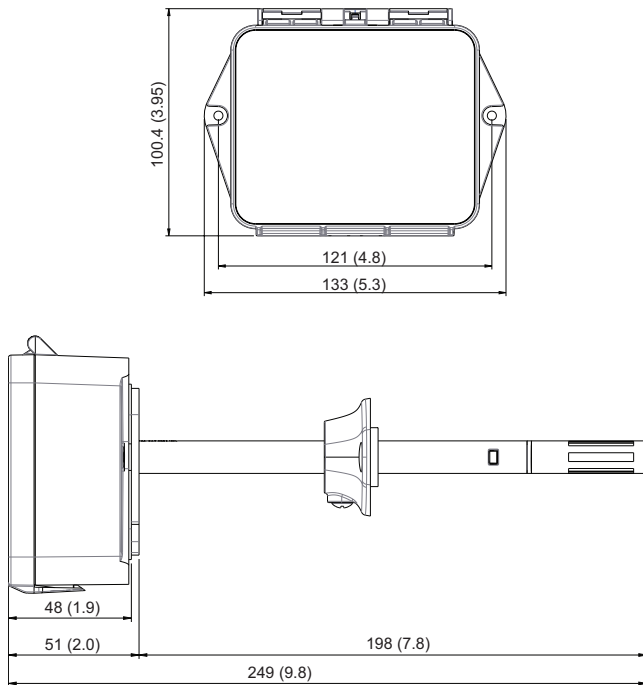

Safety Information Important Information

Read these instructions carefully and look at the equipment to become familiar with the device before trying to install, operate, service or maintain it. The following special message may appear throughout this bulletin or on the equipment to warn of potential hazards or to call attention to information that clarifies or simplifies a procedure.

NOTICE

NOTICE is used to address practices not related to physical injury.

⚠ WARNING

WARNING indicates a hazardous situation which, if not avoided **could result in death or serious injury**.

Please Note

Electrical equipment should be installed, operated, serviced and maintained only by qualified personnel. No responsibility is assumed by Schneider Electric for any consequences arising out of the use of this material.

A qualified person is one who has the skills and knowledge related to the construction, installation and operation of electrical equipment and has received safety training to recognize and avoid the hazards involved.

Safety Precautions

⚠ WARNING



HAZARD OF ELECTRIC SHOCK, EXPLOSION OR ARC FLASH

- Apply appropriate personal protective equipment (PPE) and follow safe electrical work practices. See NFPA 70E or CSA Z462.
- This equipment must only be installed and serviced by qualified electrical personnel.
- Turn off all power supplying this equipment before working on or inside equipment.
- Always use a properly rated voltage sensing device to confirm power is off.
- Replace all devices, doors and covers before turning on power to this equipment.

Failure to follow these instructions can result in death, serious injury or equipment damage.

This product is intended for use in HVAC and building environmental control applications.

It is not intended for direct medical monitoring of patients.

It is not designed for life-safety applications.

Read and understand these instructions before installing this product.

The installer is responsible for all applicable codes.

If this product is used in a manner not specified by the manufacturer, the protection provided by the product may be impaired. No responsibility is assumed by the manufacturer for any consequences arising out of the use of this material.

Installation

NOTICE

PRODUCT DAMAGE DUE TO ELECTRO-STATIC DISCHARGE

Circuit boards and components can be damaged by static electricity or electro-static discharge (ESD). Observe the following electro-static precautions when handling this product and cables and components connected to the product.

- Keep static-producing material such as plastic, upholstery, carpeting, etc. out of the immediate work area.
- Store the product in ESD-protective packaging when it is not installed in the panel
- When handling the product or a conductive cable/ESD-sensitive component connected to the product, wear a conductive wrist strap connected to ground through a minimum of 1 MΩ resistance
- Do not touch exposed conductors and component leads with skin or clothing.

Failure to follow these instructions can result in equipment damage.

Installation (cont.)

1. Prepare the duct for installation by drilling holes to accommodate the probe tube. Ensure the gasket on the back is depressed to prevent leakage between the product and the duct. Do not over-tighten the screws.

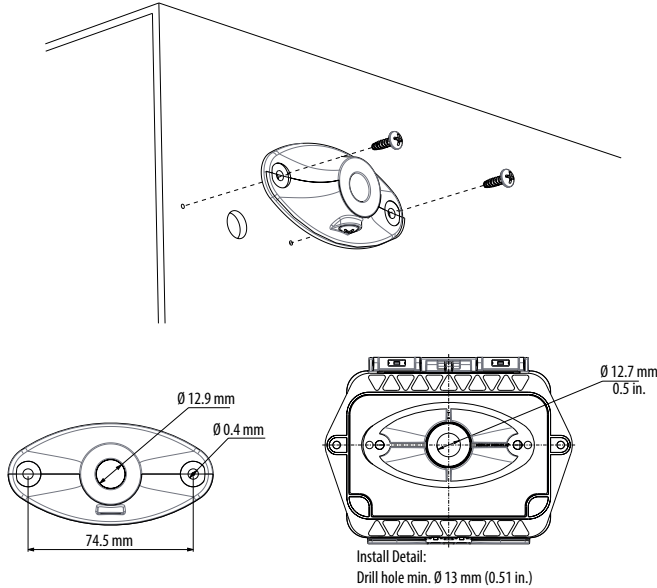

2. Ensure the probes are installed in the direction of the air flow. Install the probe in the middle of the duct and away from any restrictions to allow proper air flow.

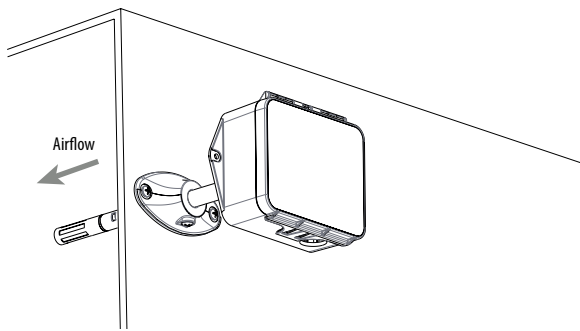

3. Release the latch on the lid to access the DIP switches and terminal block.

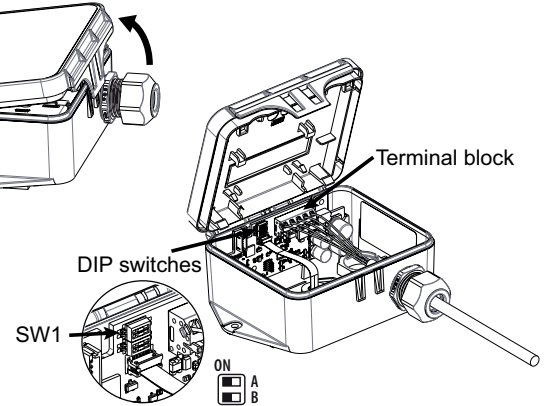

4. Wire the connections according to the diagram in the Wiring section. This device features spring terminals for screwless termination. Open the terminal point by inserting a screwdriver (#1 in diagram), then insert the wire above (#2 in diagram). Release the screwdriver to hold the wire in place. Details on wiring and configuration are contained in the next sections of this document.

NOTICE	
MISSING TEMPERATURE & HUMIDITY READINGS	
<ul style="list-style-type: none"> • Ensure flex cable is in place after wiring. 	
Failure to follow these instructions can result in no temperature or humidity readings.	

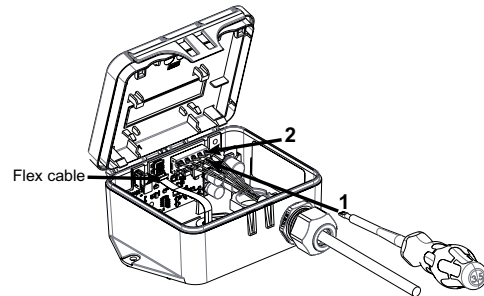

Installation (cont.)

- Secure the latch-on cover in the closed position and remove the clear protective mask on the front label of the device.

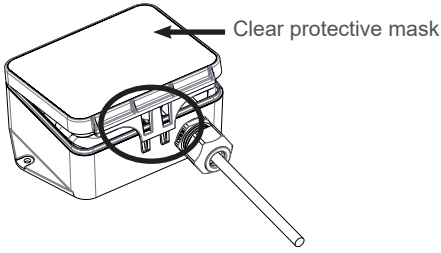

Wiring

NOTICE	
INACCURATE READINGS	
<ul style="list-style-type: none"> Do not run wiring in the same conduit as AC power wiring. Close proximity to AC power may influence accuracy. In current output mode do not use AC voltage, use 20-30V DC Volts. 	
Failure to follow these instructions can result in reduced accuracy and incorrect readings.	

Wiring Diagrams

Voltage Mode

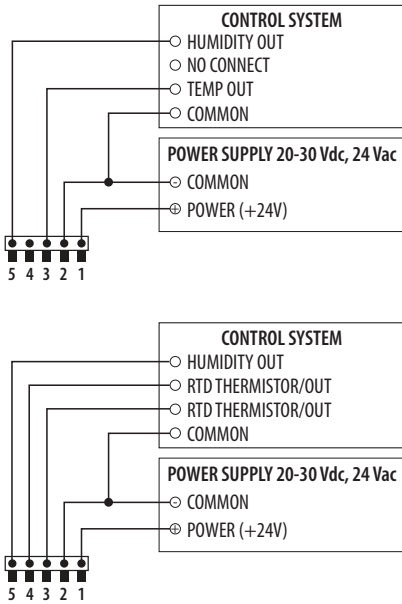

Current Mode

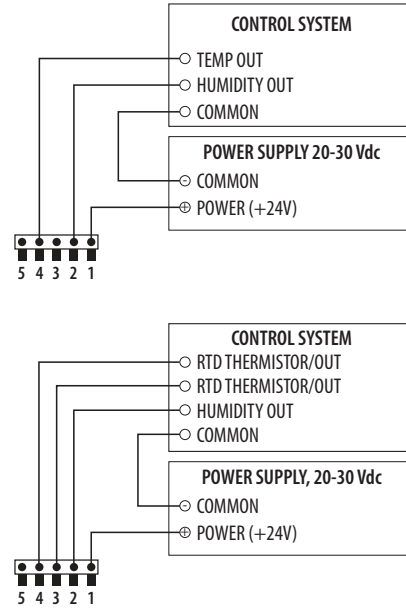

Configuration

NOTICE	
PRODUCT DAMAGE	
<ul style="list-style-type: none"> Ensure DIP switch configuration is consistent with wiring before powering the unit. In current mode, do not use AC power supply. Use 20-30 Vdc. Do not miswire the product or short the outputs. 	
Failure to follow these instructions can result in product damage.	

Set the DIP switches. White squares in the diagram below indicate switch position.

Output Mode

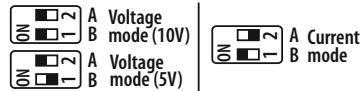

Switch	Function	Description
A	Output mode	ON - 4-20mA output mode enabled
		OFF - Voltage output mode enabled
B	Voltage output	ON - 0-5V output range enabled
		OFF 0-10V output range enabled

Standard RTD and Thermistor Values (Ω)

°C	°F	1000 Ω	10k Type 3
		RTD (PTC)	Thermistor (NTC)
-50	-58	803.06	441,300
-40	-40	842.71	239,800
-30	-22	882.22	135,200
-20	-4	921.6	78,910
-10	14	960.86	47,540
0	32	1,000.00	29,490
10	50	1,039.03	18,790
20	68	1,077.94	12,260
25	77	1,097.35	10,000
30	86	1,116.73	8,194
40	104	1,155.41	5,592
50	122	1,193.97	3,893
60	140	1,232.42	2,760
70	158	1,270.75	1,990
80	176	1,308.97	1,458
90	194	1,347.07	1,084
100	212	1,385.06	816.8
110	230	1,422.93	623.6
120	248	1,460.68	481.8
130	266	1,498.32	376.4
Sensor Codes		C	H

Maximum Power Consumption

Series	LCD	Temp./RH	Max. Power
SHD2 Analog	No	Yes	0.8VA @ 24VAC Voltage Mode 0.96W @ 24VDC Current Mode

China RoHS Compliance Information Environment-Friendly Use Period (EFUP) Table

部件名称 Part Name	有害物质 - Hazardous Substances					
	铅 (Pb)	汞 (Hg)	镉 (Cd)	六价铬 (Cr (VI))	多溴联苯 (PBB)	多溴二苯醚 (PBDE)
电子件 Electronic	X	O	O	O	O	O

本表格依据SJ/T11364的规定编制。

O: 表示该有害物质在该部件所有均质材料中的含量均在GB/T 26572规定的限量要求以下。

X: 表示该有害物质至少在该部件的某一均质材料中的含量超出GB/T 26572规定的限量要求。

(企业可在此处，根据实际情况对上表中打“X”的技术原因进行进一步说明。)

This table is made according to SJ/T 11364.

O: indicates that the concentration of hazardous substance in all of the homogeneous materials for this part is below the limit as stipulated in GB/T 26572.

X: indicates that concentration of hazardous substance in at least one of the homogeneous materials used for this part is above the limit as stipulated in GB/T 26572

Z000057-0B

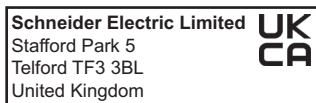

USA: +1 888-444-1311
Europe: +46 10 478 2000
Asia: +65 6484 7877
www.schneider-electric.com

Life Is On

