

en Installation Guide

EVlink Pro DC 180 Charging Station
EVlink Pro DC 150 Charging Station
EVlink Pro DC 120 Charging Station

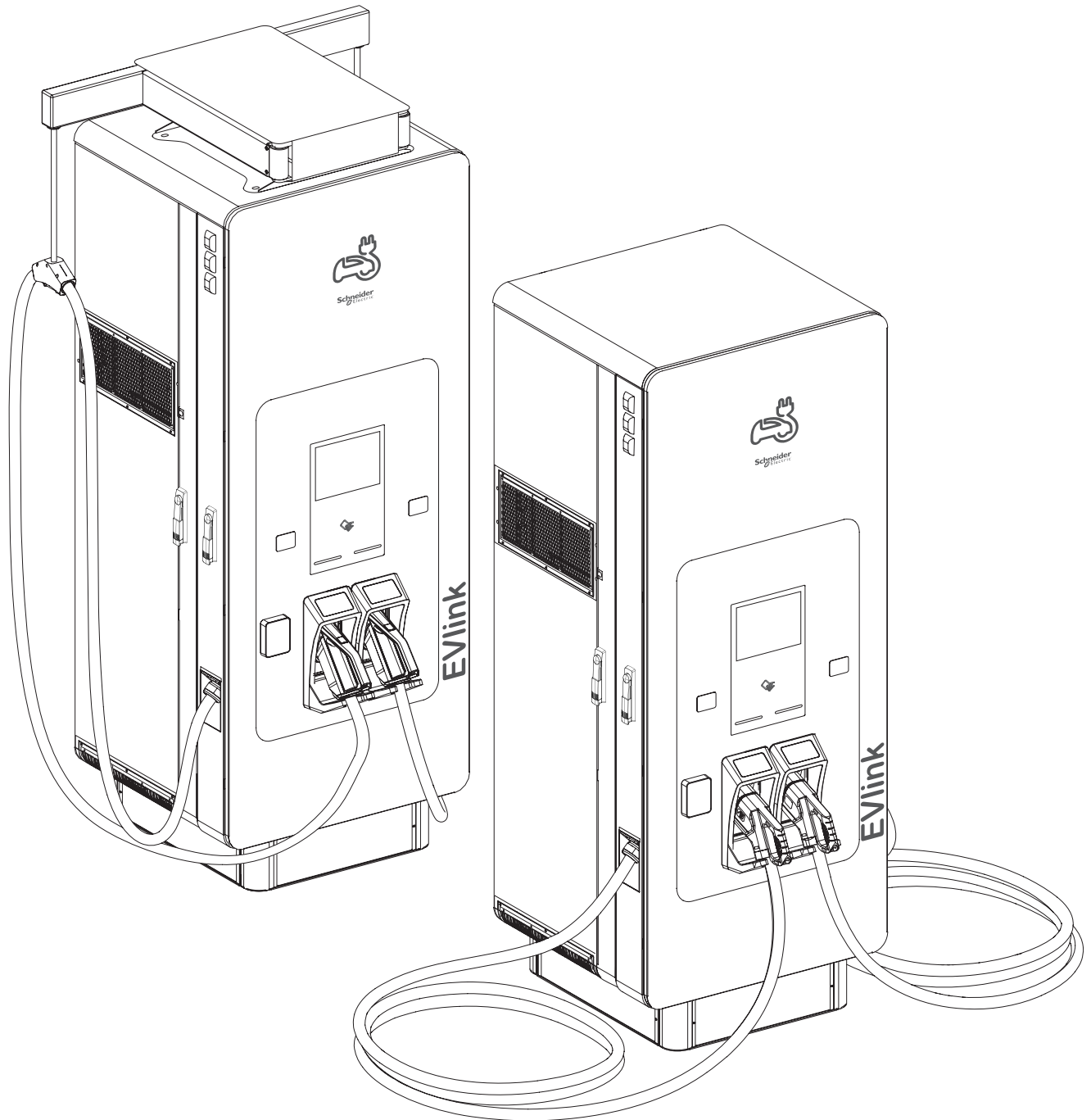

Customer Care Center

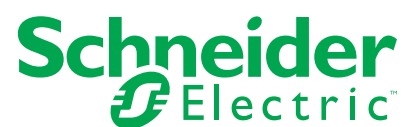
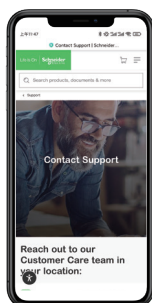

- Legal Information 3**
- General 3**
- Radio Equipment Conformity 4**
- Important 5**
- Preface 5**
- 1. System Overview 6**
- 2. Installation Environment 6**
- 3. Site Preparation 7**
 - 3.1 Maintenance Distance 7
 - 3.2 Underground Concrete Base 7
 - 3.3 Ventilation Requirements 9
 - 3.4 Parking Place Arrangements Layout 9
 - 3.5 Signage and Location 10
 - 3.6 Bollards 10
 - 3.7 Tilt / Collision Sensor 10
- 4. Electrical Requirements 11**
- 5. Communication 11**
- 6. Required Materials and Tools 12**
- 7. Receiving, Handling 12**
 - 7.1 Receiving 12
 - 7.2 Contents 13
- 8. Unpacking and Inspection 14**
 - 8.1 Inspection 14
 - 8.2 Install Cable Management (If applicable) 14
- 9. Handling and Mounting 15**
 - 9.1 Handling and Fixing in Place 15
- 10. Connecting 18**
 - 10.1 Connecting the Charging Station 18
 - 10.2 Ethernet Connection (Optional) 19
 - 10.3 Installation of 4G SIM Card (Optional) 20
- 11. Installation of Power Module 22**
- 12. Finalization 23**
- 13. Startup / Shutdown 24**
 - 13.1 Startup 24
 - 13.2 Shutdown 24
- 14. Hide Emergency charge stop button (Optional) 24**
- 15. Recycle 24**
- Appendix 1: Installation Check List 25**
- Appendix 2: Charging Station Mounting Template 26**
- Appendix 3: Schematic Diagram 27**

Legal Information



The Schneider Electric brand and any trademarks of Schneider Electric SE and its subsidiaries referred to in this guide are the property of Schneider Electric SE or its subsidiaries.

All other brands may be trademarks of their respective owners.

This guide and its content are protected under applicable copyright laws and furnished for informational use only.

No part of this guide may be reproduced or transmitted in any form or by any means (electronic, mechanical, photocopying, recording, or otherwise), for any purpose, without the prior written permission of Schneider Electric.

Schneider Electric does not grant any right or license for commercial use of the guide or its content, except for a non-exclusive and personal license to consult it on an "as is" basis.

Schneider Electric products and equipment should be installed, operated, serviced, and maintained only by qualified personnel.

As standards, specifications, and designs change from time to time, information contained in this guide may be subject to change without notice.

To the extent permitted by applicable law, no responsibility or liability is assumed by Schneider Electric and its subsidiaries for any errors or omissions in the informational content of this material or consequences arising out of or resulting from the use of the information contained herein.

General

Warning Symbols Definitions

The following safety messages may appear throughout this manual or on the equipment to warn of potential hazards or to call attention to information that clarifies or simplifies a procedure.



The addition of this symbol to a "Danger" or «Warning» safety message indicates that an electrical hazard exists which will result in personal injury if the instructions are not followed.



This is the safety alert symbol. It is used to alert you to potential personal injury hazards. Obey all safety messages with this symbol to avoid possible injury or death.

DANGER

DANGER indicates a hazardous situation which, if not avoided, **will result in death** or serious injury.

WARNING

WARNING indicates a hazardous situation which, if not avoided, **could result in death** or serious injury.

CAUTION

CAUTION indicates a hazardous situation which, if not avoided, **could result in minor or moderate injury**.

NOTICE

NOTICE is used to address practices not related to physical injury. The safety alert symbol shall not be used with this signal word.

Safety Instructions

DANGER

HAZARD OF ELECTRICAL SHOCK, EXPLOSION OR ARC FLASH

- Apply appropriate personal protective equipment (PPE) and follow safe electrical work practices or equivalent local standards.
- This equipment must only be installed, commissioned and serviced by qualified electrical personnel.
- Turn off all power supplying this equipment before working on or inside equipment.
- Always use a properly rated voltage sensing device to confirm power is off.
- Do not use this product if the enclosure, EV cable, or the EV connector is broken, cracked, open, or shows any other indication of damage.
- Do not put fingers or objects into the electric vehicle connector.
- The use of extension DC cables or vehicle connector adapters is not permitted.

Failure to follow these instructions will result in death or serious injury.

WARNING

HAZARD OF DEGRADATION OF EQUIPMENT PERFORMANCE

- Do not store flammable and explosive materials near the Charging Station.
- In case of overheating or fire starting near the Charging Station, press the emergency charge stop button of the Charging Station and unplug the car. Move away from the Charging Station and call the fire department.

Failure to follow these instructions can result in death, serious injury, or equipment damage.

CAUTION

HAZARD OF DEGRADATION OF EQUIPMENT PERFORMANCE

- You must be a licensed electrician and complete a training course to become a EVlink Pro DC Charging Station certified installer.
- Schneider Electric will not accept any liability for consequences arising from the use of this material. Do not modify any mechanical or electrical parts.
- A qualified person is a person who has the skills and know-how relating to the construction, installation and operation of electrical equipment and who has received a safety training which enables him to recognize and avoid risks.

Failure to follow these instructions can result in injury or equipment damage.

NOTICE

RISK OF DAMAGING

- EVlink Pro DC Charging Station should be installed, operated, serviced and maintained only by qualified personnel.
- Schneider Electric will not accept any liability for consequences arising from the use of this material.
- A qualified person is a person who has the skills and know-how relating to the construction, installation and operation of electrical equipment and who has received a safety training which enables him to recognize and avoid risks.

Failure to follow these instructions can result in equipment damage.

Radio Equipment Conformity

EU Declaration of Conformity

EVlink Pro DC 180 is in compliance with the essential requirements and other relevant provisions of Radio Equipment Directive: 2014/53/EU.

The EU declaration of conformity for EVlink Pro DC 180 offer (EU1006186-3) can be downloaded on: www.se.com/docs.

UK Declaration of Conformity

EVlink Pro DC 180 is in compliance with the essential requirements and other relevant provisions. of Radio Equipment Regulations 2017-UK SI 2017 No.1206.

The UK declaration of conformity for EVlink Pro DC 180 offer (UK1006187-1) can be downloaded on: www.se.com/uk/docs.

Communication Frequencies

	Operation Frequency	Output Power
RFID:	13.56 MHz	Far less than 20 mW
GSM900:	TX: 880 MHz to 915 MHz RX: 925 MHz to 960 MHz	32.75 dBm
GSM1800:	TX: 1710 MHz to 1785 MHz RX: 1805 MHz to 1880 MHz	29.80 dBm
WCDMA		
Band1:	TX: 1920-1980 MHz RX: 2110-2170 MHz	24.37 dBm
Band8:	TX: 880-915 MHz RX: 925-960 MHz	24.07 dBm
LTE		
Band1:	TX: 1920-1980 MHz RX: 2110-2170 MHz	23.51 dBm
Band3:	TX: 1710-1785 MHz RX: 1805-1880 MHz	23.55 dBm
Band7:	TX: 2500-2570 MHz RX: 2620-2690 MHz	23.5 dBm
Band8:	TX: 880-915 MHz RX: 925-960 MHz	23.91 dBm
Band20:	TX: 832-862 MHz RX: 791-821 MHz	23.88 dBm
Band28:	TX: 703-748 MHz RX: 758-803 MHz	23.59 dBm
Band38:	2570-2620 MHz (TDD)	23.51 dBm
Band40:	2300-2400 MHz (TDD)	23.18 dBm

Wireless Frequencies

Operate Freq. Band	Frequency Range (MHz)	Modulation	Channel Bandwidth	Data Rate
IEEE 802.11b	2412 ~ 2472	DSSS	20MHz	Up to 11Mbps
IEEE 802.11g	2412 ~ 2472	OFDM	20MHz	Up to 54Mbps
IEEE 802.11n 2.4GHz 20MHz	2412 ~ 2472	OFDM	20MHz	Up to 72.2Mbps
Channel Number	IEEE 802.11b/g, IEEE 802.11n HT20: 13 Channels			
Channel Step	WiFi: Channels with 5MHz step			

Standards and Compliance

Directive RE: 2014/53/UE	RE Directive: 2014/53/EU
Directive RoHS: 2011/65/UE, 2015/863/UE	RoHS Directive: 2011/65/EU: 2015/863/EU

Based on following standards:

EN IEC 61851-1:2019, EN 61851-1:2011, EN 61851-23:2014+AC:2016-06, EN 61851-24:2014 + AC:2015,
 EN 61000-6-2:2005 + AC:2005, EN IEC 61000-6-2:2019*, EN 61000-6-4:2007 + A1:2011, EN IEC 61000-6-4:2019**, EN IEC 61851-21-2:2021***
 EN 301 489-1 V1.9.2(2011-09), EN 301 489-1 V2.2.3(2019-11)****, EN 301 489-3 V2.3.2(2023-01), EN 301 489-17 V3.2.4(2020-09),
 EN 301 489-52 V1.2.1(2021-11)
 EN 300 330 V2.1.1(2017-02), EN 301 511 V12.5.1(2017-03), EN 301 908-1 V15.2.1(2023-01), EN 301 908-2 V13.1.1(2020-06), EN 301 908-13 V13.2.1 (2022-02)
 EN 300 328 V2.2.2, EN 62311:2008, EN IEC 62311:2020
 IEC 61439-7:2 018
 EN ISO 15118-1:2019, EN ISO 15118-2:2016, EN ISO 15118-3:2016, EN ISO 15118-4:2019
 EN ISO 15118-5:2019
 EN IEC 63000:2018
 EN 18031-1:2024, EN 18031-2:2024, EN 18031-3:2024

* The EN IEC 61000-6-2:2019 is not an harmonized standard but the EVlink Pro DC 180kW is already compliant with EN IEC 61000-6-2:2019.

** The EN IEC 61000-6-4:2019 is not an harmonized standard but the EVlink Pro DC 180kW is already compliant with EN IEC 61000-6-4:2019.

*** The EN IEC 61851-21-2:2021 is not an harmonized standard but the EVlink Pro DC 180kW is already compliant with EN IEC 61851-21-2:2021.

**** The EN 301 489-1 V2.2.3(2019-11) is not an harmonized standard but the EVlink Pro DC 180kW is already compliant with EN 301 489-1 V2.2.3(2019-11).

Important



To help you make the best use of your Charging Station, we have prepared this manual with the utmost care.

It provides all the information you need to prepare for the installation and to install your equipment.

We urge you to read it attentively and follow its instructions.

- The product must be installed according to the specifications and requirements as defined by Schneider Electric. No responsibility is assumed by Schneider Electric if these requirements are not respected.
- Non-approved installation methods are performed at the risk of the contractor and void the (limited) warranty.
- Under no circumstances will compliance with the information in this manual relieve the user of his/her responsibility to comply with all applicable codes or safety standards.
- This document describes the most used installation and mounting scenarios. If situations arise in which it is not possible to perform an installation following the procedures provided in this document, contact Schneider Electric.
- Schneider Electric is not responsible for any damages that may result from custom installations that are not described in this document or for any failure to adhere to installation recommendations.

Preface

This guide describes the planning and physical installation of the EVlink Pro DC 120 or 150 or 180 Charging Stations. The EVlink Pro DC Charging Stations are easy to install DC fast Charging Stations for electric vehicles. Fast Charging Stations are electrical installations with high electric currents. Therefore, the installation must be planned carefully, and must be done by certified personnel only (according to local standards).

The EVlink Pro DC 120/150 is physically the same Charging Station as a DC 180. The main difference is the output power it can deliver and therefore also the input power needed. The differences of the DC120/150 and 180, and the consequences for the installation are described in the scope of application section.

As the physical installation of all types is equal, they will be referred to hereafter as EVlink Pro DC 180 only and this will account for all types, unless specifically stated otherwise. EVlink Pro DC 180 is available in different versions, depending on the outlet types. The different versions are described in the scope of application section.

NOTE: Installing the EVlink Pro DC 180 Charging Station requires at least two people and takes approximately 1-2 hours. This time estimate does not include the time needed to commission the Charging Station.

Scope of Application

Type of equipment applicable to this manual: EVlink Pro DC 120 kW – DC 150 kW - DC 180 kW
List of references supported are:

Commercial Reference	Nominal Power	Vehicle connector	Cable management	Cable range (m)	Payment Terminal	Eichrecht version	Australia/New Zealand version
EVD1S180TBB	180 kW DC	2 x CCS2	Yes	3.6	No	No	No
EVD1S150TBB	150 kW DC	2 x CCS2	Yes	3.6	No	No	No
EVD1S120TBB	120 kW DC	2 x CCS2	Yes	3.6	No	No	No
EVD1S180TBBC7	180 kW DC	2 x CCS2	No	7.5	No	No	No
EVD1S150TBBC7	150 kW DC	2 x CCS2	No	7.5	No	No	No
EVD1S120TBBC7	120 kW DC	2 x CCS2	No	7.5	No	No	No
EVD1S180TBCC	180 kW DC	2 x CCS2	Yes	3.6	Yes	No	No
EVD1S150TBCC	150 kW DC	2 x CCS2	Yes	3.6	Yes	No	No
EVD1S120TBCC	120 kW DC	2 x CCS2	Yes	3.6	Yes	No	No
EVD1S180TBB-AN	180 kW DC	2 x CCS2	Yes	3.6	No	No	Yes
EVD1S150TBB-AN	150 kW DC	2 x CCS2	Yes	3.6	No	No	Yes
EVD1S120TBB-AN	120 kW DC	2 x CCS2	Yes	3.6	No	No	Yes
EVD1S180TBBC7-AN	180 kW DC	2 x CCS2	No	7.5	No	No	Yes
EVD1S150TBBC7-AN	150 kW DC	2 x CCS2	No	7.5	No	No	Yes
EVD1S120TBBC7-AN	120 kW DC	2 x CCS2	No	7.5	No	No	Yes
EVD1S180TBCC-G	180 kW DC	2 x CCS2	Yes	3.6	No	Yes	No
EVD1S150TBCC-G	150 kW DC	2 x CCS2	Yes	3.6	No	Yes	No
EVD1S120TBCC-G	120 kW DC	2 x CCS2	Yes	3.6	No	Yes	No
EVD1S180TBBC7-G	180 kW DC	2 x CCS2	No	7.5	No	Yes	No
EVD1S150TBBC7-G	150 kW DC	2 x CCS2	No	7.5	No	Yes	No
EVD1S120TBBC7-G	120 kW DC	2 x CCS2	No	7.5	No	Yes	No

* For more customized commercial reference, please contact Schneider Electric.

⚠ CAUTION

RISK OF TRIPPING ON LOOSE CABLE

For versions not equipped with cable management system, it is mandatory to allocate a solution or space to place the cable in order to prevent cars from running on it.

Failure to follow these instructions can result in injury or equipment damage.

Available Documentation

EVlink Pro DC available documents for each phase of the project:

Document	Reference	Content	Audiences
EVlink Pro DC 180 Datasheet	998-22029850	Full Charging Station specifications	Site designer, installer, and station operator
EVlink Pro DC 180 Installation Guide	GEX4300800	Civil, mechanical, and electrical installation guidelines	Site engineer or installer/contractor
EVlink Pro DC 180 Owners Guide	GEX4301000	Operation and maintenance guidelines	Site operator and end user
EVlink Pro DC OCPP Guide	DOCA0311	Integration rule of charger for Charge Point Operator	Charge Point Operator / Contractor
EVlink Pro DC Modbus Connectivity Guide	D3973814	Modbus connectivity guidelines for energy management system intergration	Charge Point Operator / Contractor
EVlink Pro DC Cybersecurity Guide	BRU5102501	Cybersecurity rules and guidelines	Charge Point Operator / Contractor
EVlink Pro DC OCMF Guide	DOCA0310	Eichricht version connectivity guide for Charge Point Operator	Charge Point Operator / Contractor

1 System Overview

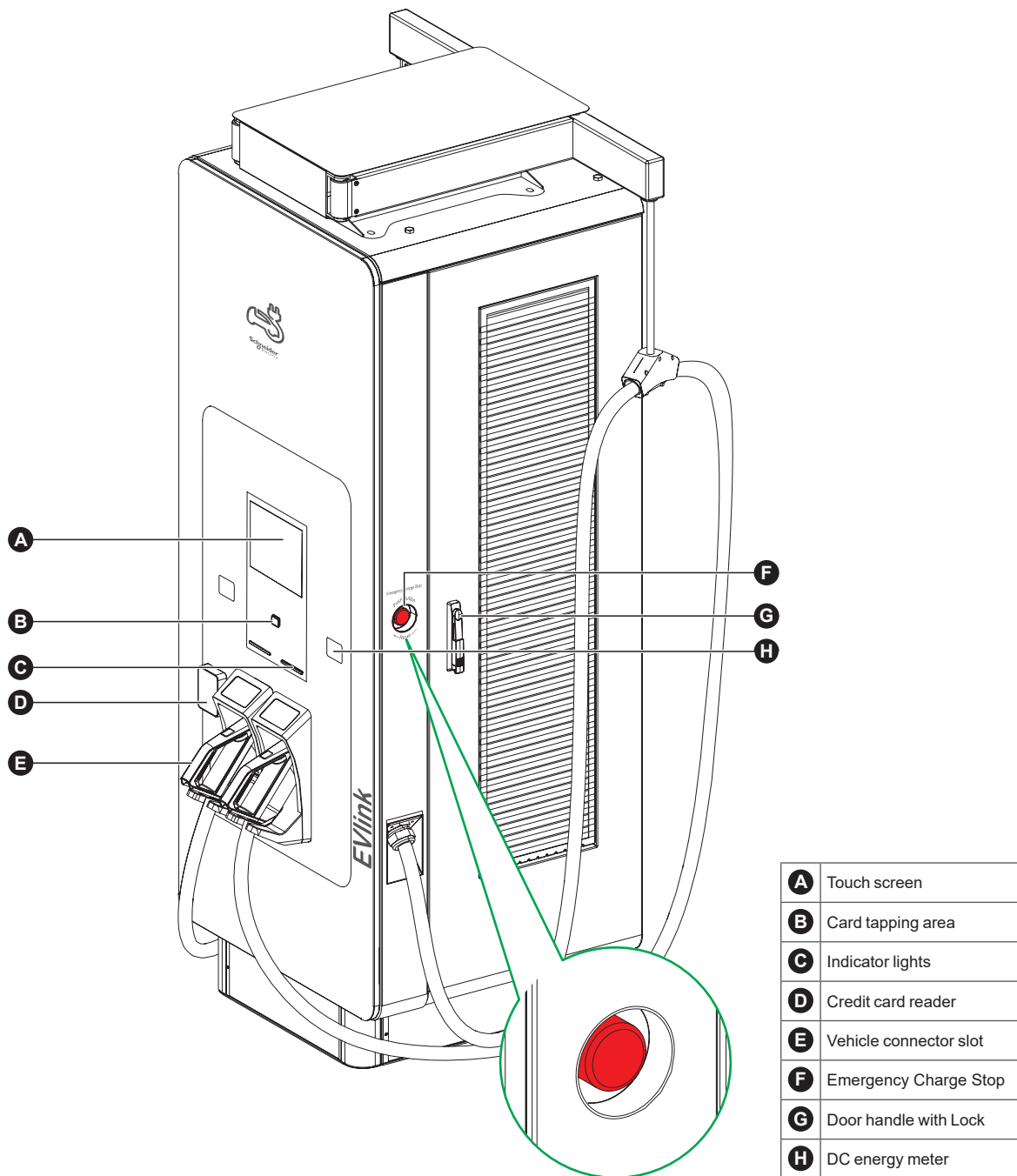

Image showing version equipped with cable management system and credit card reader.

2 Installation Environment

The environmental conditions listed in the table below should be taken into consideration when selecting the installation site of the EVlink Pro DC Charging Station.

Environmental parameter	Permissible Conditions
EMC environment	Industrial environment – Class A
Ambient temperature	-30°C ~ 50°C, derating after 50°C
Humidity	10%~ 95%
Altitude	Up to 2000 m
Degree of protection	IP55
Mechanical impact protection	IK10 (IK08 for screen)
Pollution degree	PD2
Mounting method	Stationary equipment, ground mounted or floor mounted
Ambience	Non explosive environments Housing corrosion protection level C4M Example of environment <ul style="list-style-type: none"> ■ Outdoor: Urban and industrial atmospheres, moderate sulphur dioxide pollution, coastal area with low salinity ■ Indoor: Production rooms with high humidity and some air pollution
Location	Avoid accumulation of sand, dust, snow etc with non-restricted access

NOTE: Contact Schneider Electric if the Charging Station will be installed closer than 4 km to a sea/ocean coastline.

3 Site Preparation

3.1 Maintenance Distance

NOTICE

RISK OF EQUIPMENT DAMAGE

Always follow the instructions described below when Charging Stations need to be installed near walls or other obstacles, a certain maintenance distance needs to be allocated. Failure to follow these instructions can result in equipment damage.

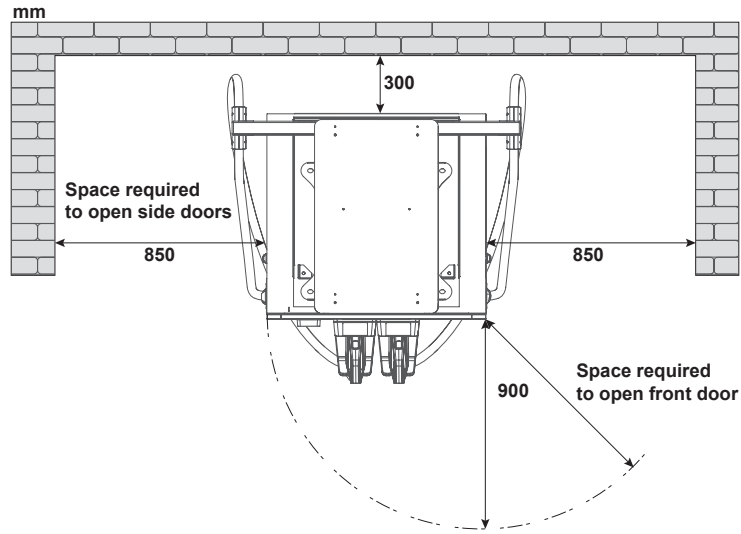

NOTE: Ensure that enough space is available around the installation pad to use a forklift and other lifting equipment, unpack crates, remove packing materials, and allow two people to freely move throughout the area. For versions equipped with Cable Management System, It is recommended to allow for 500 mm clear space above the Charging Station to allow for maintenance.

3.2 Underground Concrete Base

⚠ WARNING

HAZARD OF HEAVY EQUIPMENT FALLING

- The EVlink Pro DC shall be mounted on concrete flooring. If the Charging Station will be installed outdoors in sandy or soil ground or on a frost line, a concrete base is mandatory.
 - Always follow the instructions and information provided in this guide or a Schneider Electric-approved mounting solution, to install the EVlink Pro DC 180.
 - Non-approved installation methods are performed at the risk of the contractor and void the limited warranty.
- Failure to follow these instructions can result in death, serious injury, or equipment damage.**

Before beginning work, check that the site meets these civil and mechanical requirements outlined below, as illustrated in the following image.

1. Underground concrete base guidelines

- The concrete pad must have a site drawing approved by a structural engineer for this specific site considering the soil behavior and/or any frost line and conforms to the mentioned specifications.
- Ensure a flat surface level with slight outward slope to drain any water, ensuring no obstacles prevent water draining from the base.
- The top of the concrete base must not be lower than the 0 finish floor level. However it may be higher according to the different site situations and local regulations.
- Please consider the height of the screen and the vehicle connector when designing the concrete base elevation.

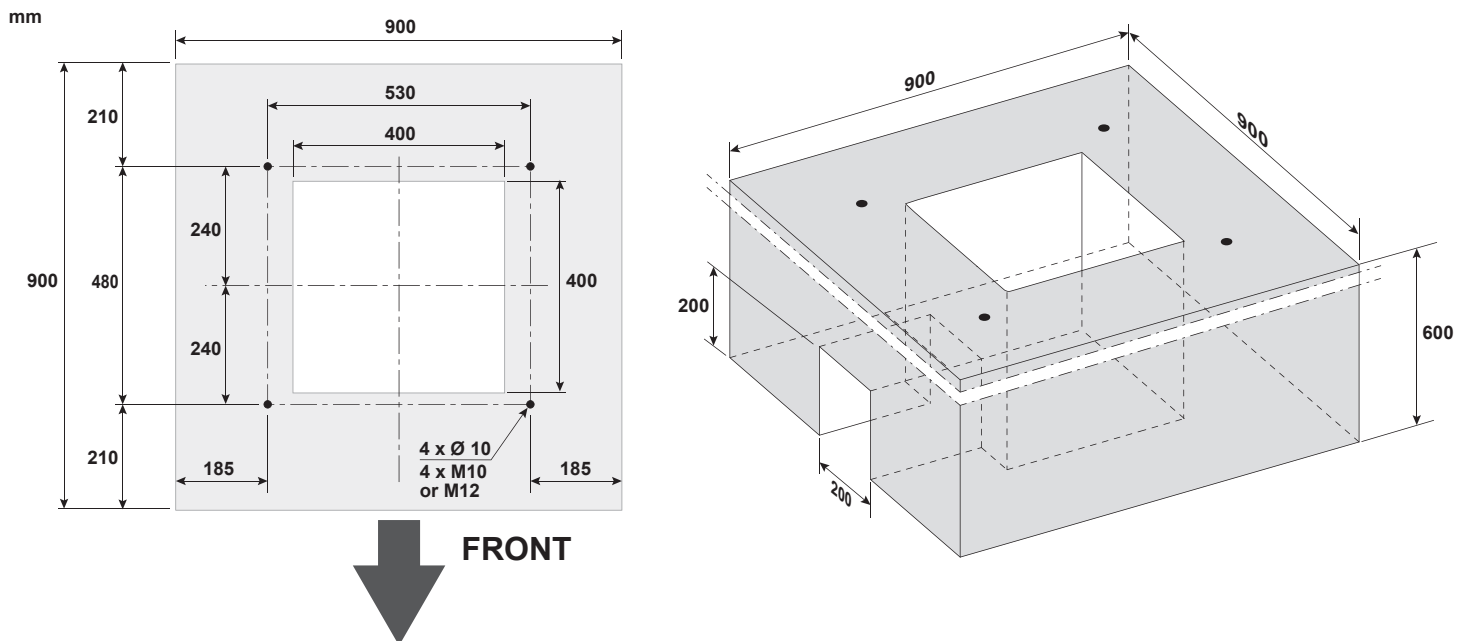

- After the concrete has dried, 4 x M10 or M12 screws with length L = 250 mm are fixed into the concrete pad according to the provided template (Appendix 2) with 30 - 40 mm of threads exposed.

3 Site Preparation

3.2 Underground Concrete Base

2. Installation and construction

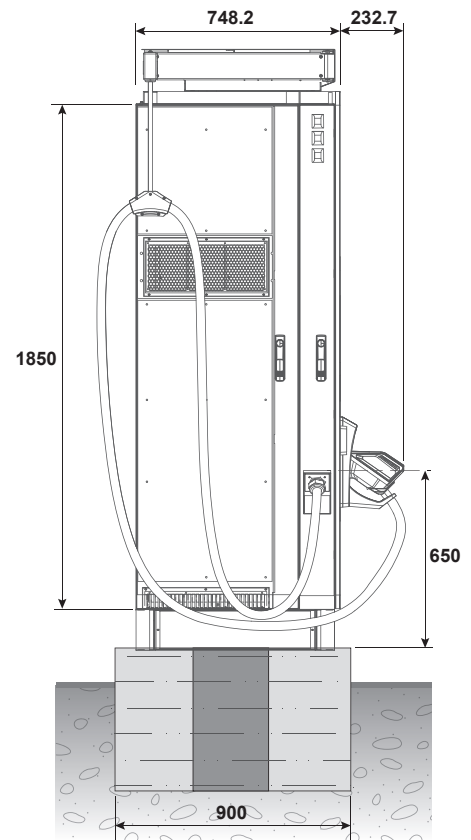
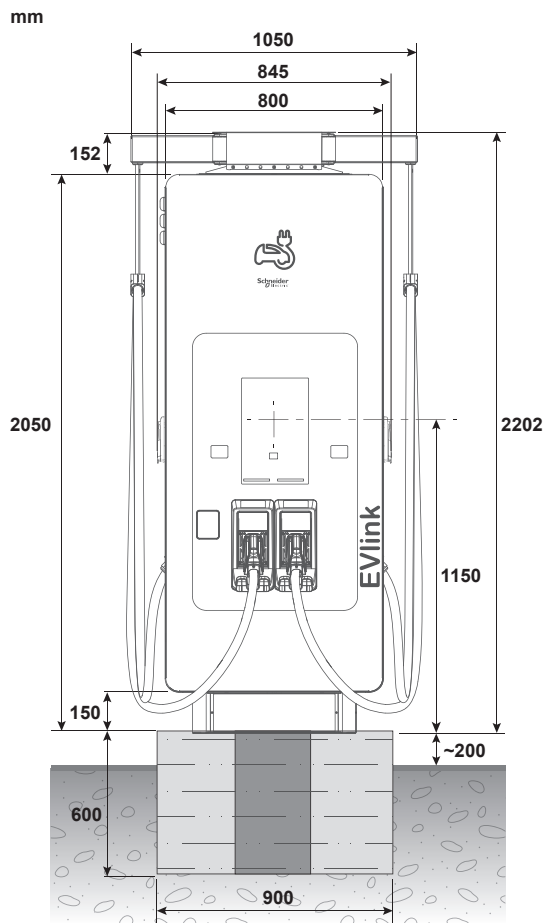

3 Site Preparation

3.3 Ventilation Requirements

Ventilation of the Charging Station

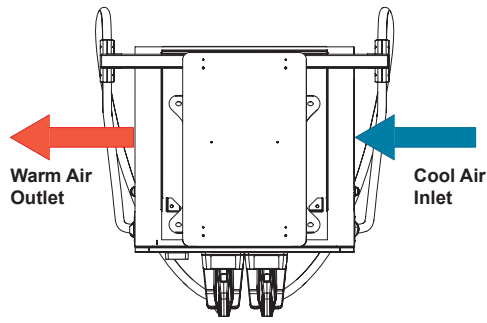

NOTE: If necessary, take precautions to prevent snow or objects from blocking the inlets, outlets or the operation of the cable management system.

3.4 Parking Place Arrangements Layout

It is possible to position the EVlink Pro DC 180 such that several parking spots can be served. But only two vehicles can be charged at a time. Some possible arrangements of parking places in relation to the EVlink Pro DC 180 are shown in the figures that follow.

NOTE: The usable connector cable range with optional Cable Management System is 3.6 m.
For all other references the full length of the cable is usable providing extended range of 7.5 m.

■ The cover ranges of 5m charging cable with cable management:

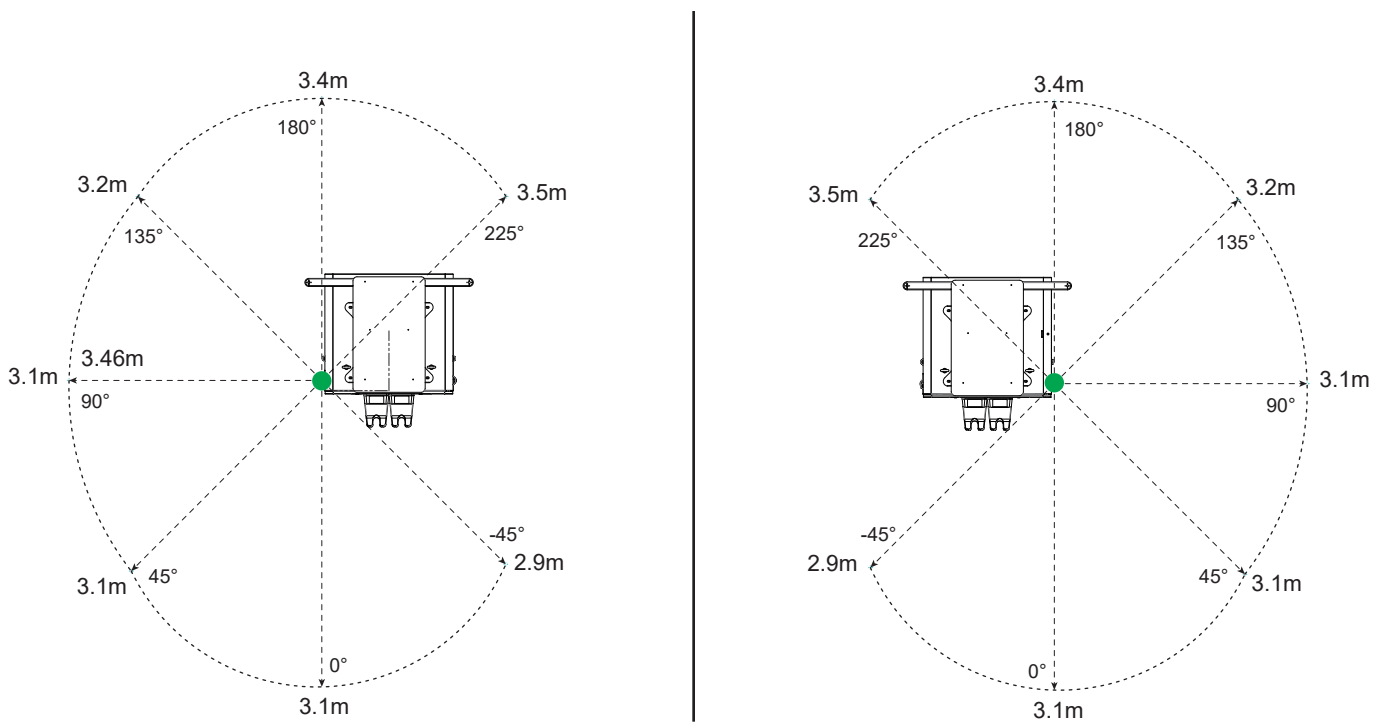

3 Site Preparation

3.4 Parking Place Arrangements Layout

- The cover ranges of 7.5m charging cable without cable management:

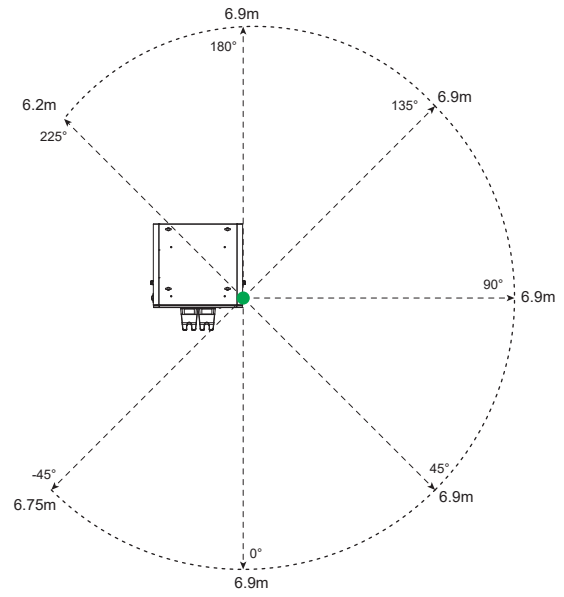
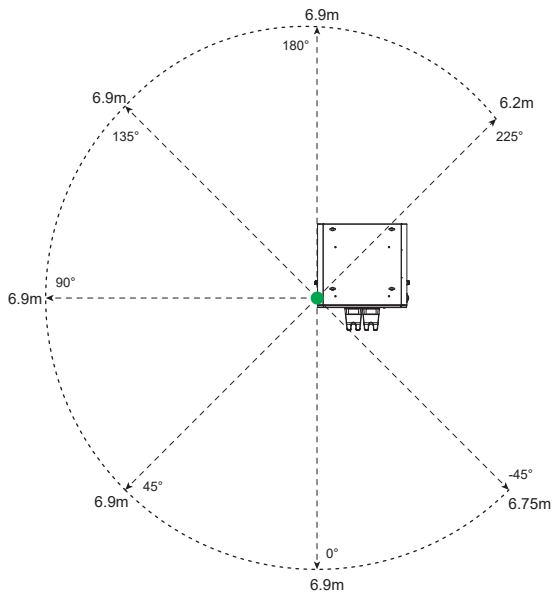

3.5 Signage and Location

Use road signs and / or special marking to direct drivers to the Charging Station locations and to distinguish the Electric Vehicle parking spaces from ICE (Internal Combustion Engine) vehicles spaces.

To provide a secure comfortable environment for users, and to prevent vandalism and / or theft:

- Install the Charging Station in a location where it can be clearly seen and / or monitored.
- Use 24/7 security control.
- Install sufficient lighting around the Charging Station.
- For a comfortable user experience, it is recommended to install a shed or other protection from the direct sunlight while using the charging station.

3.6 Bollards

It is advised to place bollards around the Charging Station to protect against cars collisions.

NOTE: Bollards limiting the access

When installing bollards around the Charging Station make sure all doors can still be opened to be able to service the Charging Station.

In case bollard are installed that are blocking the doors, make sure they are the removable kind.

If removable bollards are used, ensure the tool/key required to remove them is available in case of the Charging Station requiring services.

3.7 Tilt / Collision Sensor

EVlink Pro DC 180 is equipped with a tilt sensor that will interrupt output power/charging session if the sensor detects a tilt in the cabinet in any direction, for example if a vehicle collides with the charging station.

If triggered the indicator light will turn RED and any ongoing charging session will stop. The relevant error message will be shown on screen and an error code will be relayed to the OCPP backend if connected.

4 Electrical Requirements

▲ WARNING

RISK OF FIRE AND/OR EQUIPMENT DAMAGE

- Ensure the appropriate circuit protection, and metering is in place at the installation site.
- Ensure that a grounding conductor that complies with local codes is properly grounded to earth at the power distribution equipment.
- Ensure that a correctly rated, dedicated breaker is installed for each Charging Station.
- In the event of irregularities or disturbances in the operation of the device press the emergency charge stop button and unplug your car.
- If the maximum power delivered by the product is modified, it has to be indicated on the product by customer.

Failure to follow these instructions can result in death, serious injury, or equipment damage.

The electrical requirements for each type of Charging Station shall be followed according to this table:

Electrical Parameters

Rated supply voltage	380 V – 415 Vac +/- 10 % 50 / 60 Hz
Earthing system	TT/TN-S / TN-C-S
Protection against electric shock	Class I
Connection method	Permanently connected
Rated insulation voltage	500 V
Rated impulse withstand voltage	4 kV
Rated conditional short-circuit current	30 kA
Power factor	0.99 at nominal output power
Efficiency	94.5 % at nominal output power
THDi	≤ 5 % at nominal output power

Upstream Protection

Circuit breaker* *It is required to use circuit breaker, and type A residual current protection may be installed upstream in accordance with local regulations or customer application.	3PH + N + PE
Nominal output power	120 kW 150 kW 180 kW
Rated input current	193 A 242 A 291 A
Max input current	214 A 268 A 323 A

Upstream Cables

Suggested cable type	U1000 R2V Fine or Extra Fine Wire Strands
----------------------	---

Cable Entry**

Maximum conductor cross section/phase:	240 mm ²
Maximum outer cable diameter/phase:	31 mm

**For additional flexibility in installations with different cable cross sections and/or number of cables per phase, the EVlink Pro DC 180 is delivered with 2 different cable entry plates.

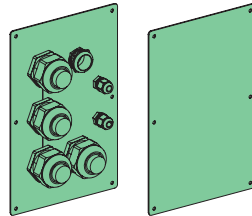

NOTE: The necessary cable size calculations need to be verified according to site conditions, cable route, length, voltage drop. If you have future upgrade plans, it is recommended to install electric infrastructure suitable for the future installation. Bimetallic lugs must be used in the case of Aluminum cables.

5 Communication

1. Cellular and wireless signal

Use a signal detection device to ensure the signal is within the recommended strength according to the below guidelines:

Signal Quality	Cellular Signal	CSQ
Excellent		> 15
Fair		2 to 14
Poor		< 2

(Note that these numbers are negative, so -70 dBm is stronger than -85 dBm, and -90 dBm is weaker).

Signal Quality	Wireless LAN Signal (WIFI)	CSQ
Excellent		> -70
Fair		-70 to -90
Poor		< -90

2. Ethernet cable

Use RJ45 cat 6, shielded, twisted pairs.

6 Required Materials and Tools

1. Specific equipment

Before you go to the site, please prepare the following tools/equipment:

- Forklift/Crane
- Step ladder
- Personal Protective Equipment (PPE)
- Cable cutter
- Wire stripper
- Wire presser/pliers
- Power drill
- Spirit level
- Toolbox
- Multimeter
- LOTO (Lock Out Tag Out) equipment

NOTE: The above tools should be selected according to the actual situation on-site.

7 Receiving, Handling

7.1 Receiving

DANGER

HAZARD OF HEAVY EQUIPMENT FALLING

Do not stand or move beneath the crate as it is being lifted or tilted.

Failure to follow these instructions will result in death or serious injury.

WARNING

HAZARD OF EQUIPMENT FALLING

- When handled from the bottom, the Charging Station must be lifted with care and held in place during transport by properly strapping them onto the forklift or handling equipment.
 - Always transport and store the Charging Station in its original packaging.
 - Ensure the load rating of all lifting equipment (forklift, crane and lifting straps, etc) is adequate for the weight of the Charging Station as shown below.
- Failure to follow these instructions can result in death, serious injury, or equipment damage.**

DANGER

HAZARD OF ELECTRIC SHOCK, EXPLOSION, OR ARC FLASH

- Do not install the Charging Station during harsh weather.
 - If you must complete the installation in rain or wind, you must use a weather-proof shelter that covers all boxes and components to avoid water entering inside the enclosure.
 - Ensure upstream protection breaker is locked in the Open (Off) position and a voltage absence test is performed before starting the installation.
 - Do not use power tools during installation or servicing. Over-torquing can damage the equipment.
- Failure to follow these instructions will result in death or serious injury.**

7 Receiving, Handling

7.2 Contents

Inside the EVlink Pro DC shipping box you should find the below mentioned items and documents.
If there are any missing items or documents, please contact Schneider Electric for the necessary replacements:

Item	Quantity
Charging Station mounting template	1
EVlink Pro DC Charging Station (120, 150 or 180)	1
Power modules	4, 5 or 6
Keys	3
Lifting rings	4
Generic RFID badge (for testing)	2
User guidance sticker	1
Bottom entry cable plate	2
Emergency charge stop cover plate	1

Documents

Installation manual

Each EVlink Pro DC (120, 150 or 180) Charging Station ships in one crate. Ensure you have correct crate at the installation site.

Contents	Shipping dimensions (mm)	Shipping weight (kg)
EVD1S180TBB	H 2440 x W 1250 x D 1100	646
EVD1S150TBB	H 2440 x W 1250 x D 1100	631
EVD1S120TBB	H 2440 x W 1250 x D 1100	616
EVD1S180TBBC7	H 2440 x W 1250 x D 1100	627
EVD1S150TBBC7	H 2440 x W 1250 x D 1100	612
EVD1S120TBBC7	H 2440 x W 1250 x D 1100	597
EVD1S180TBCC	H 2440 x W 1250 x D 1100	646
EVD1S150TBCC	H 2440 x W 1250 x D 1100	631
EVD1S120TBCC	H 2440 x W 1250 x D 1100	616
EVD1S180TBB-AN	H 2440 x W 1250 x D 1100	646
EVD1S150TBB-AN	H 2440 x W 1250 x D 1100	631
EVD1S120TBB-AN	H 2440 x W 1250 x D 1100	616
EVD1S180TBBC7-AN	H 2440 x W 1250 x D 1100	627
EVD1S150TBBC7-AN	H 2440 x W 1250 x D 1100	612
EVD1S120TBBC7-AN	H 2440 x W 1250 x D 1100	597
EVD1S180TBCC-G	H 2440 x W 1250 x D 1100	646
EVD1S150TBCC-G	H 2440 x W 1250 x D 1100	631
EVD1S120TBCC-G	H 2440 x W 1250 x D 1100	616
EVD1S180TBBC7-G	H 2440 x W 1250 x D 1100	627
EVD1S150TBBC7-G	H 2440 x W 1250 x D 1100	612
EVD1S120TBBC7-G	H 2440 x W 1250 x D 1100	597

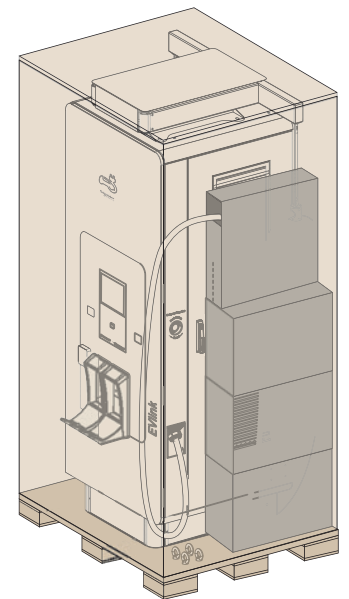

Image showing version equipped with Cable Management System.

8 Unpacking and Inspection

⚠ WARNING

RISK OF EQUIPMENT DAMAGE

- 2 operators and step ladders are required to safely unbox the EVlink Pro DC Charging Station.
 - The power modules are inside the shipping box so take caution while opening the side of the box.
 - The power modules should remain in their cartons until the Charging Station is installed in the final location.
- Failure to follow these instructions can result in death, serious injury, or equipment damage.**

⚠ CAUTION

HAZARD OF SHARP EDGES

It is recommended to wear protection gloves when unpacking the Charging Station as there could be sharp edges.

Failure to follow these instructions can result in injury.

⚠ CAUTION

HAZARD OF POTENTIAL LOOSE COMPONENTS INSIDE BOX

- At receiving always inspect the Tilt and Shock sensors on the crate for potential damage or mishandling.
 - If the sensors are triggered do not attempt to unpack, inform the transport agent and refuse reception.
- Failure to follow these instructions can result in injury or equipment damage.**



Unpacking steps:

- Place the Charging Station crate close to where it will be installed.
- Remove the top cover of the wooden crate.
- Proceed to removing the side panels of the crate.
- Remove the inner foam protection profiles.
- Carefully remove the plastic wrapping around the charger and carefully remove the power module boxes.

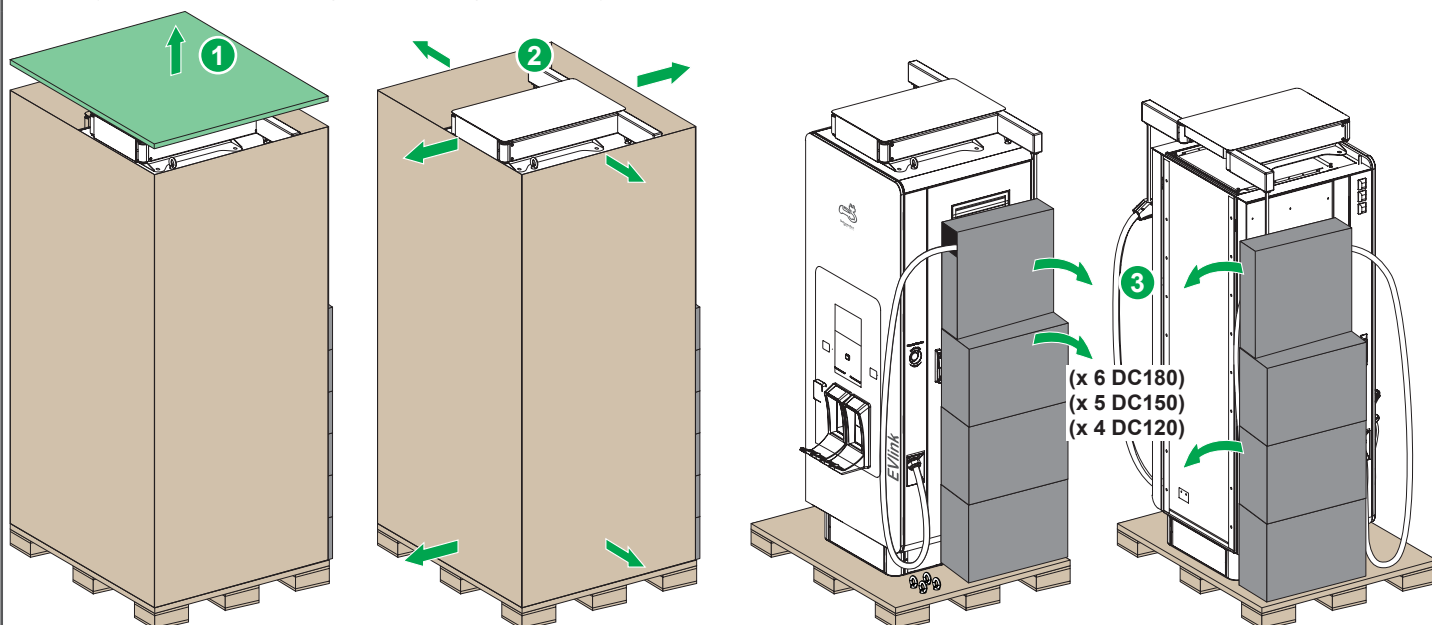

8.1 Inspection

After unpacking the EVlink Pro DC, the installer should check all the items below:

- Appearance: check whether the appearance of the Charging Station is damaged, whether there is any damage such as paint loss, scratch, deformation, and whether the structure of Charging Station is damaged during transportation.
- Labels: check whether the nameplate of Charging Station is correct, clear and complete, and whether the safety warning signs are posted in place.
- Contents: check whether the documents and accessories are complete according to the list of contents above.
- After inspection ensure the Charging Station is covered/protected from the weather.

8.2 Install Cable Management (If applicable)

Unpack the DC cable from its attached BOX and attach to the cable management system before lifting the charger.

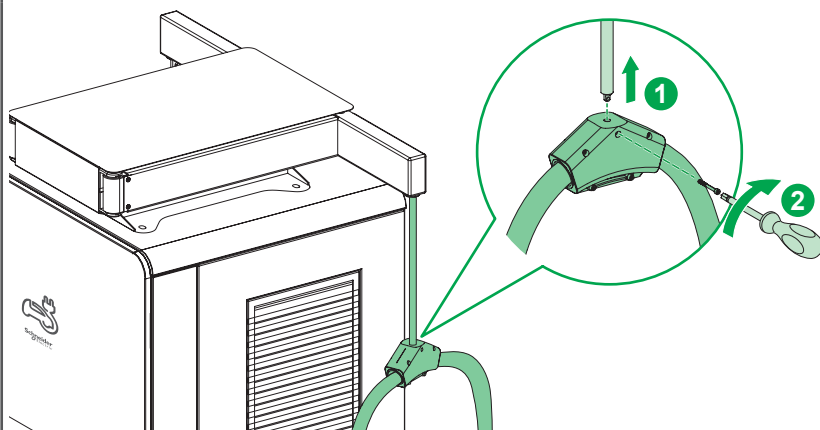

9 Handling and Mounting

9.1 Handling and Fixing in Place

▲ WARNING

HAZARD OF HEAVY EQUIPMENT FALLING

- The EVlink Pro DC 180 weighs at least 500 kg without power modules installed, ensure appropriate hoisting ropes and machinery.
 - Extreme caution must be exercised while handling, lifting, or hoisting the Charging Station.
 - Personal Protective Equipment required, hard hat, safety shoes, gloves.
- Failure to follow these instructions can result in death, serious injury, or equipment damage.**

1. Before hoisting:

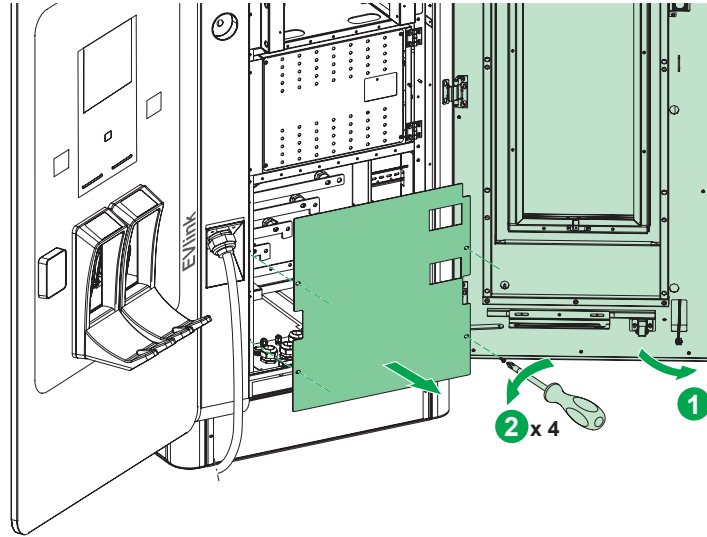

- Before lifting the Charging Station open the right door and remove the cover plate to expose the copper bars.
- Replace with the provided gland plate for larger cross sections if required.
- Remove the lifting rings from the pallet.

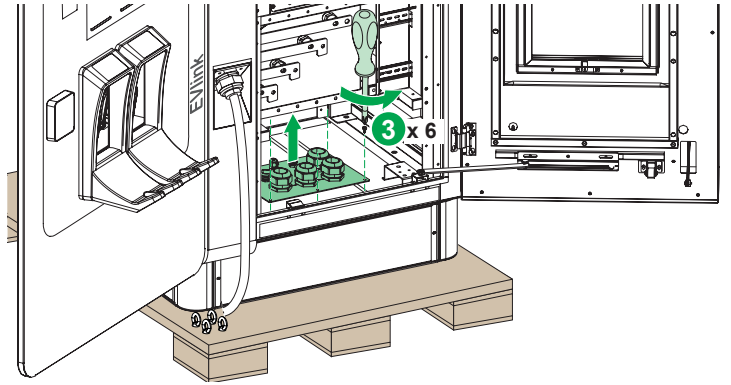

2. Hoisting:

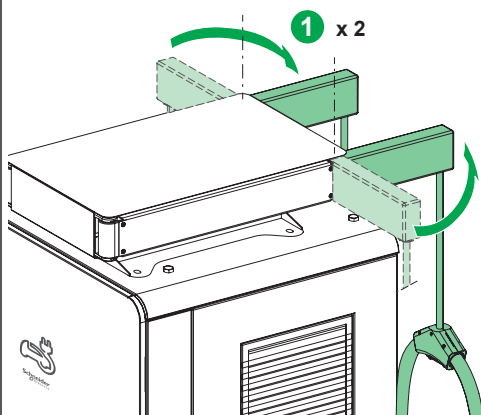

Unscrew 4 screws.

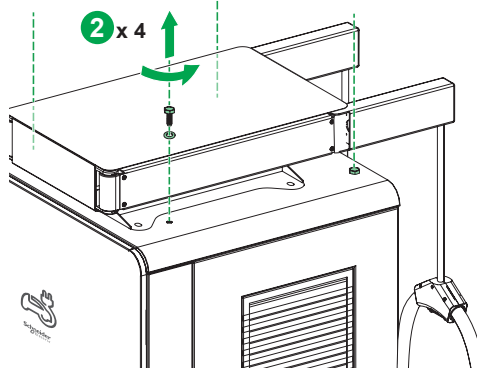

Screw the rings.

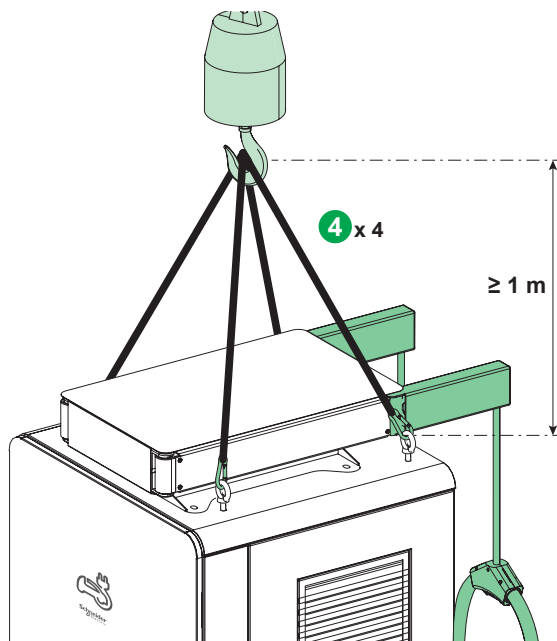
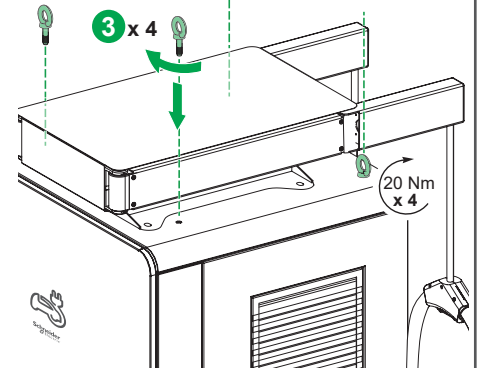

- Each of the top 4 lifting rings shall have a rope at each lifting point. Keep the hoisting angle of the rope between 45° and 60°. The force center of the hook shall be located at a symmetrical force center.
- Ensure the suitable rope length.

NOTE: The Charging Station can be damaged if the suitable rope length is not used. The door shall be closed when lifting the charger.

9 Handling and Mounting

9.1 Handling and Fixing in Place

2. Hoisting

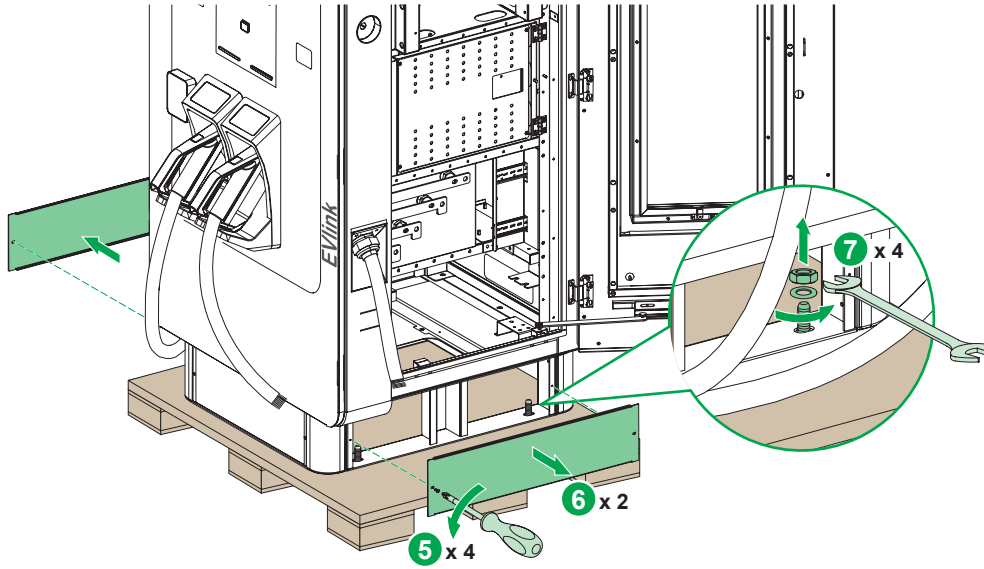

- Ensure the charger is supported from top before removing the pallet.
- The Charging Station can be hoisted.

3. Fixing

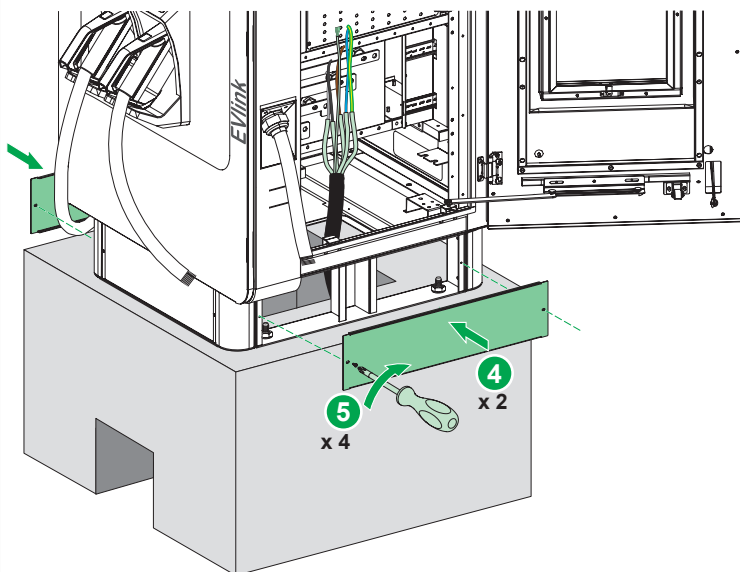
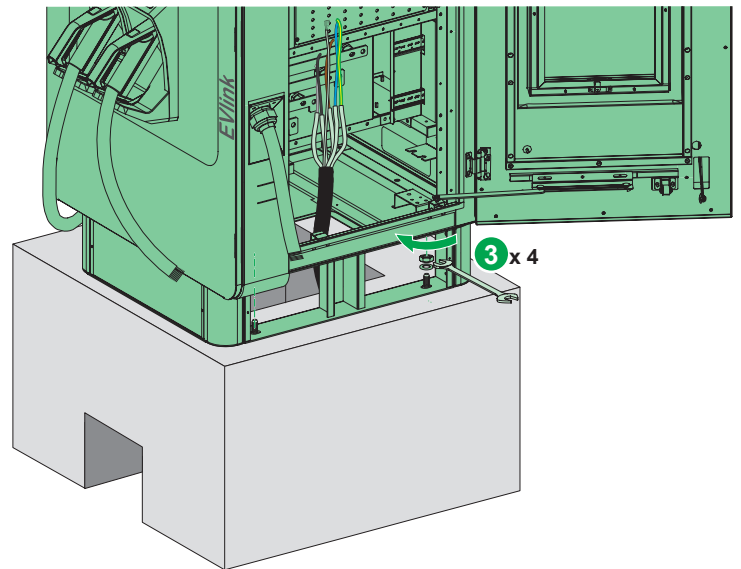
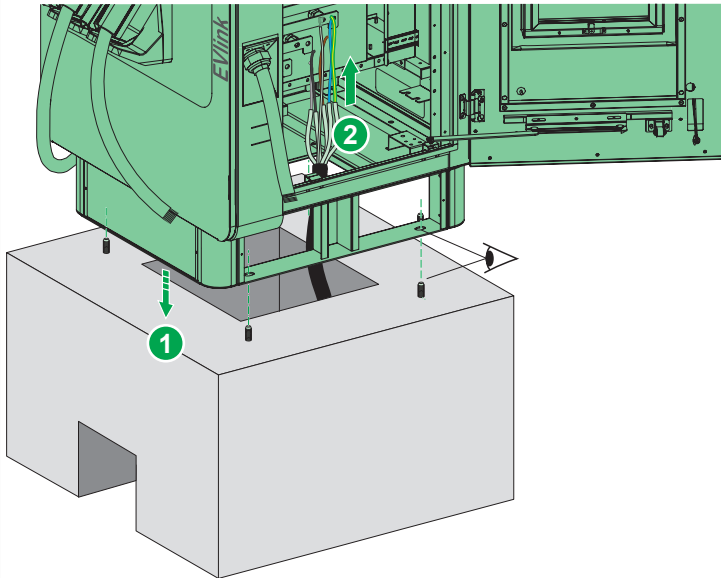

9 Handling and Mounting

9.1 Handling and Fixing in Place

3. Fixing

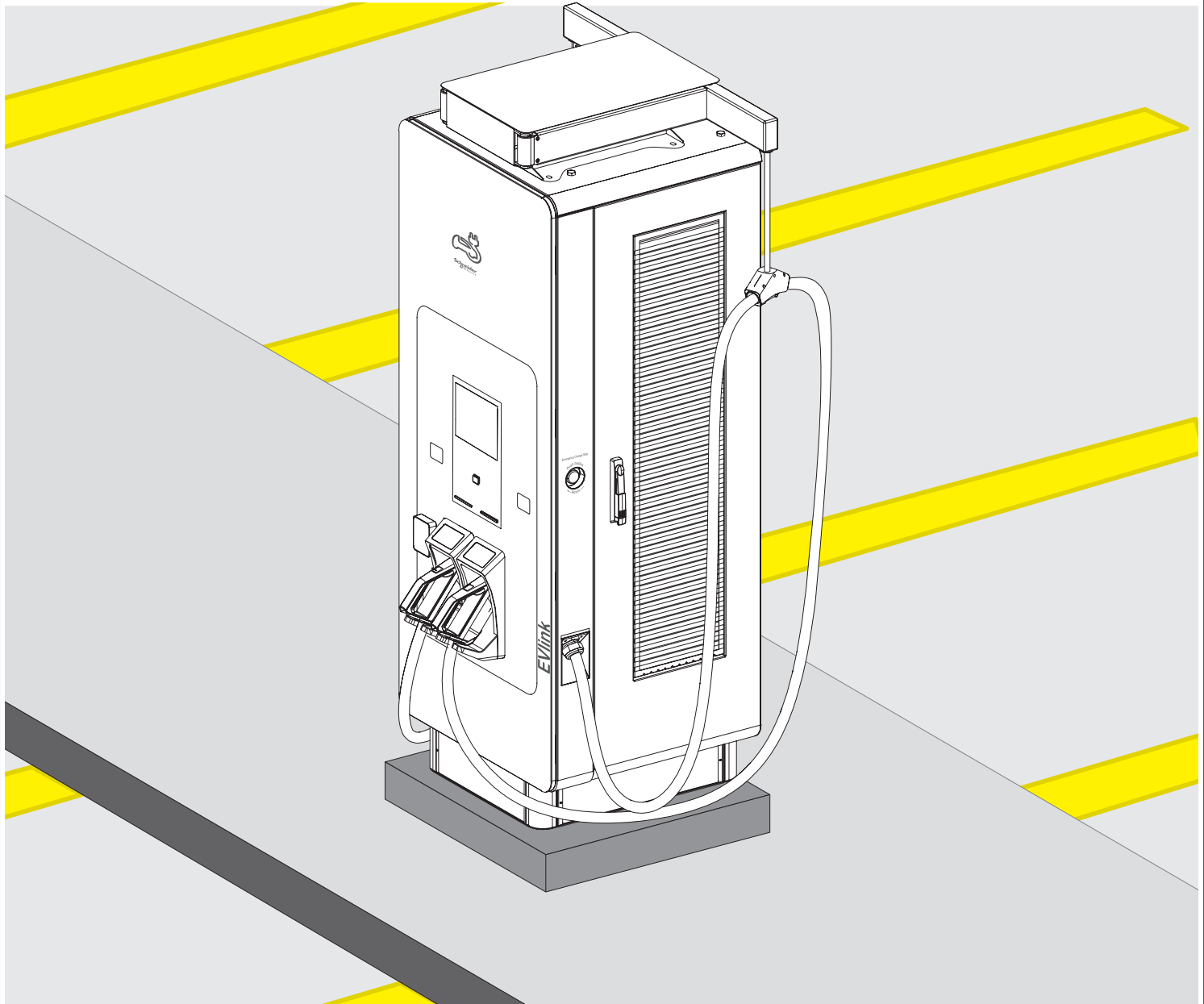
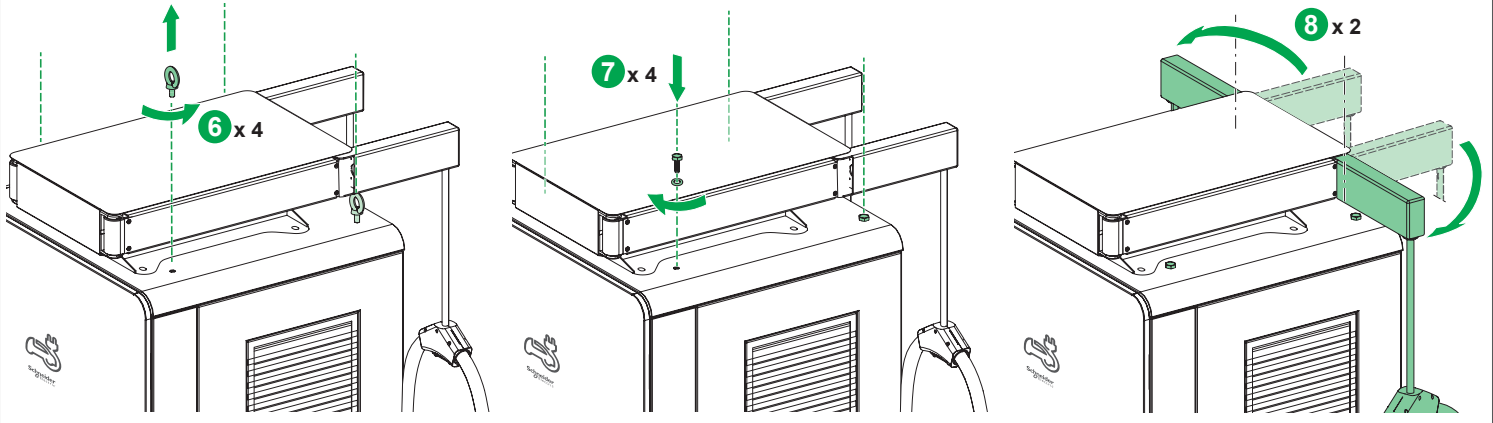

10 Connecting

10.1 Connecting the Charging Station

⚠ ⚠ DANGER

HAZARD OF ELECTRIC SHOCK

- It is mandatory to make the PE wire longer than the phase wires to ensure that the PE wire stays connected the longest if the Charging Station is moved by an accident/collision.
 - Always connect the protective earth first, before connecting the N and phase wiring.
- Failure to follow these instructions will result in death or serious injury.**

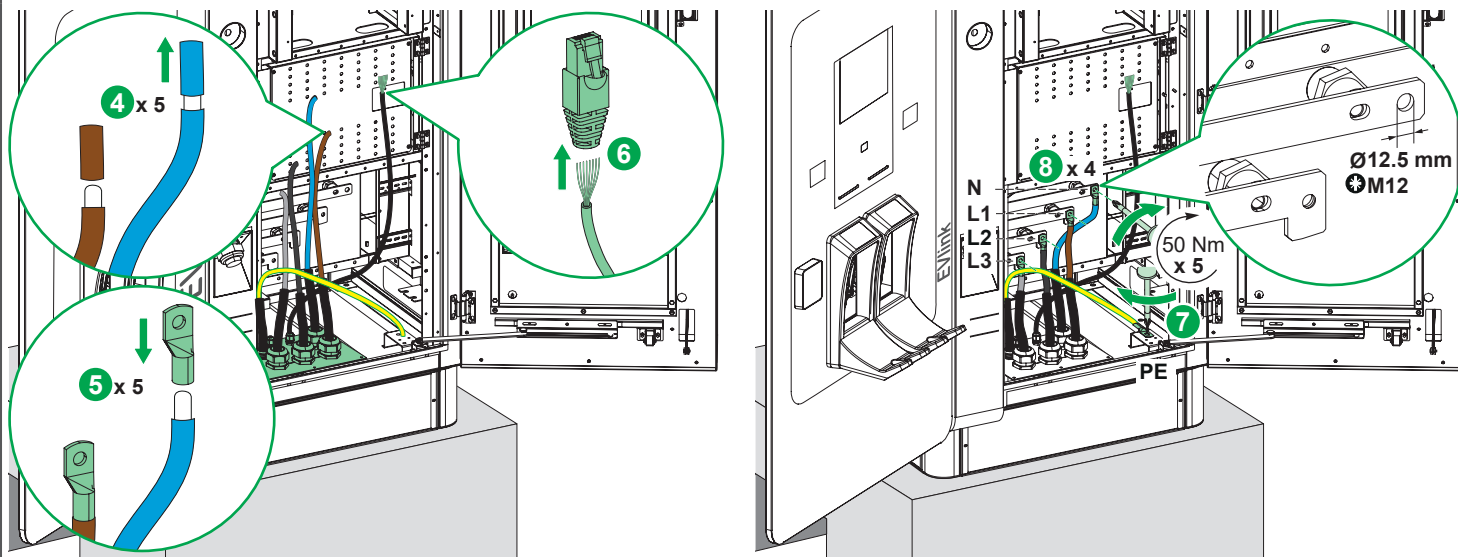
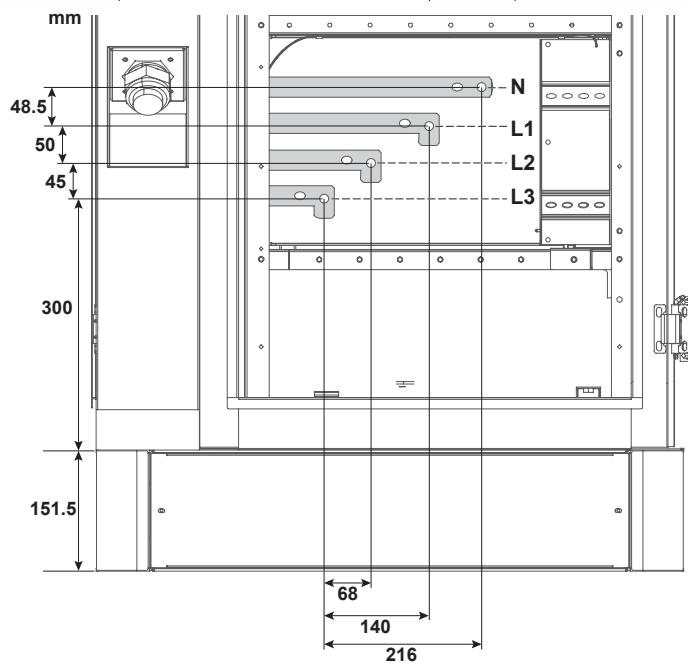
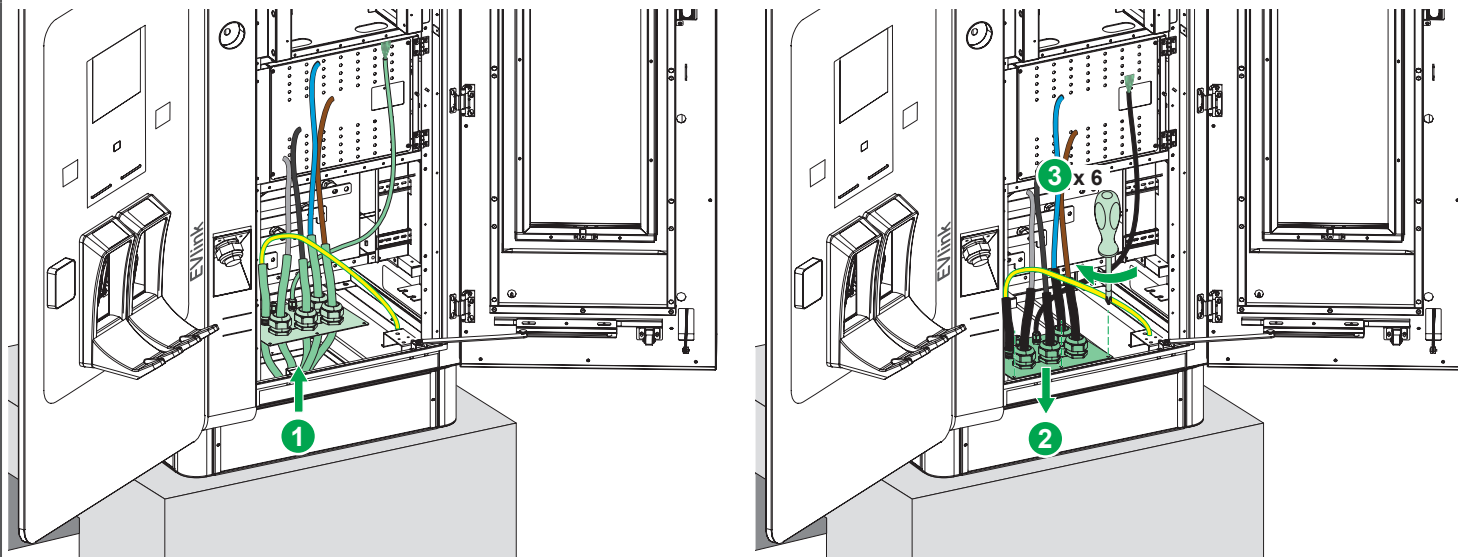

10 Connecting

10.2 Ethernet Connection (Optional)

NOTE: In order to be able to open the front door easily, it is necessary to remove the vehicle connectors from their holders.

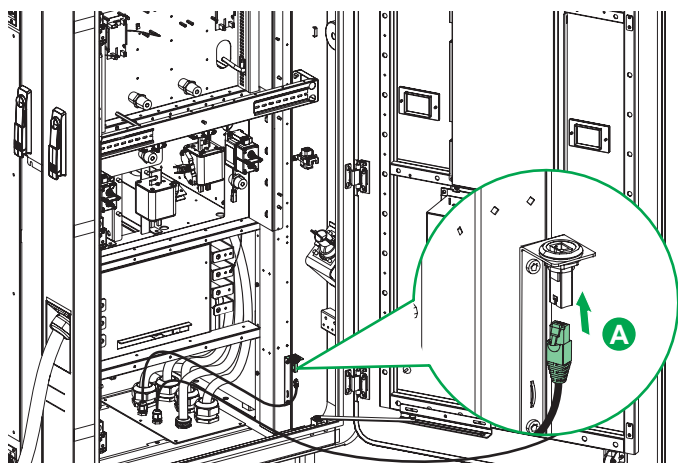
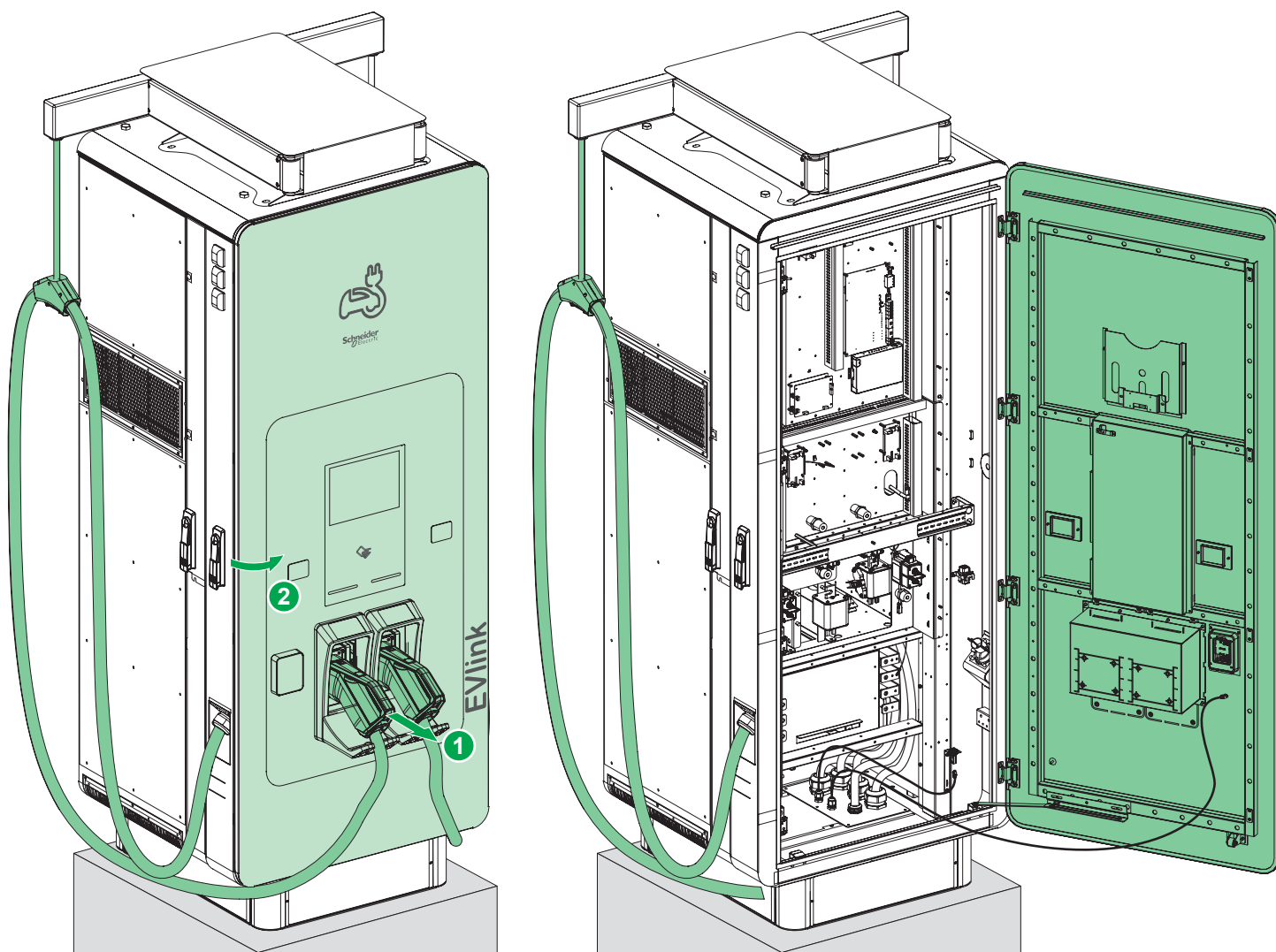

A • Connect the RJ45 plug ethernet cable.

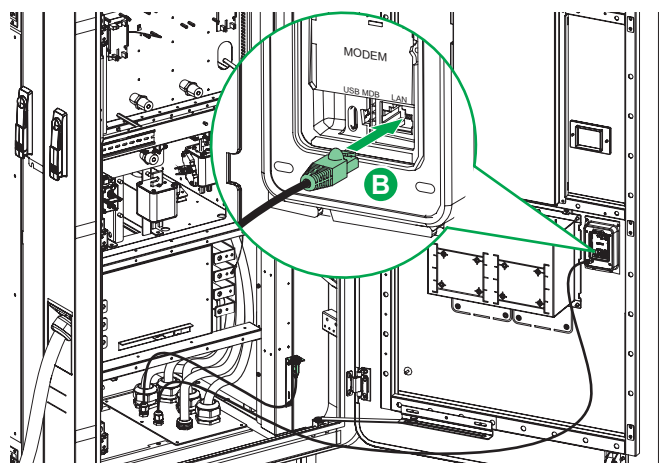

B • Connect the RJ45 Credit card payment terminal plug.
(This step is optional as Payter Apollo has it own integrated SIM card.)

10 Connecting

10.3 Installation of 4G SIM Card (Optional)

1. 4G SIM Card for connectivity to Ecostruxure Energy Asset Portal

Ecostruxure Energy Asset Portal is a tool permitting to Schneider Electric to monitor remotely the Charging Station in order to be able to troubleshoot and if possible repair from remote the Charging Station in case of issue.

You can contact Schneider service team to know more on how you can benefit from this service and get the necessary SIM Card to have the service activated.

NOTE: If the Connectivity to Ecostruxure Energy Asset Portal is needed, 4G SIM Card must be installed.

The SIM Card slot is able to receive a standard 25 mm SIM Card only.

The 4G SIM Card is provided by Schneider.

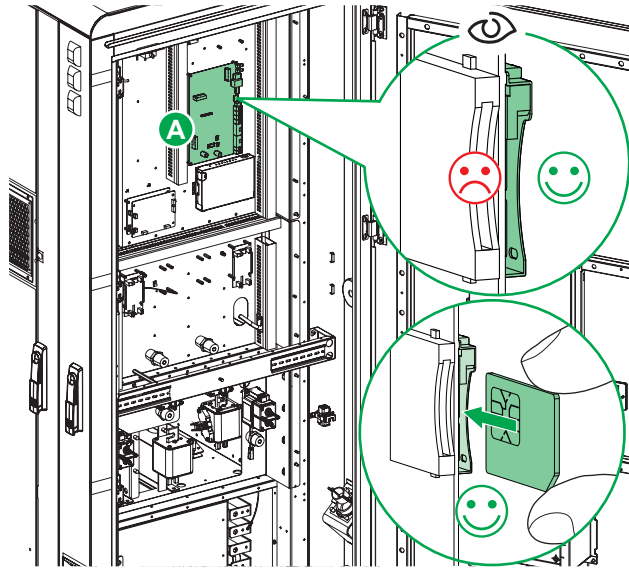

A • Locate the communication circuit board A7 board (CB01) indicated in the image.

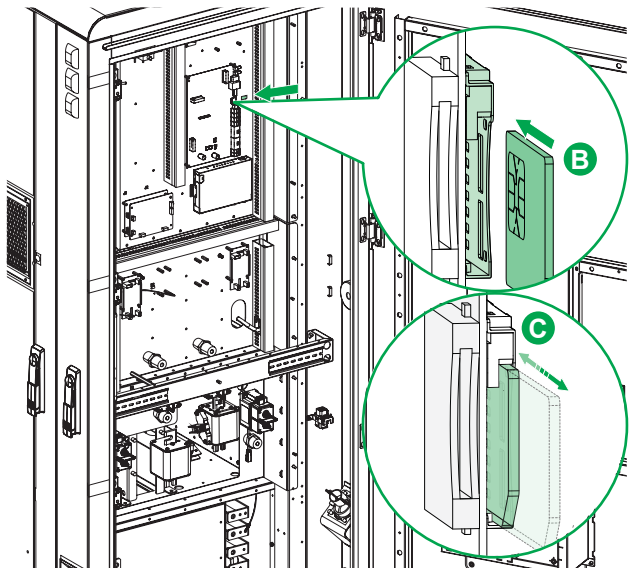

B • Carefully insert the SIM Card in the dedicated slot shown in the image.

C • To remove the SIM Card, pull the SIM Card out of the slot.

10.3 Installation of 4G SIM Card (Optional)

2. 4G SIM Card for CPO connectivity

NOTE:

- If the CPO connectivity is 4G, 4G SIM Card should be installed.
- The SIM Card slot is able to receive a Mini 25 mm SIM Card only.
- The 4G SIM Card is provided by customer.

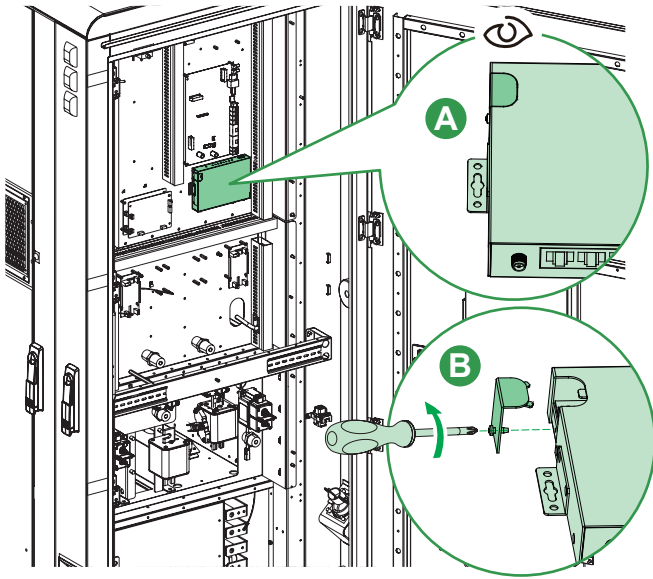

- A** • Locate the router indicated in the image.
- B** • Using a small cross screwdriver, remove the small red sheet metal on the left side of the router.

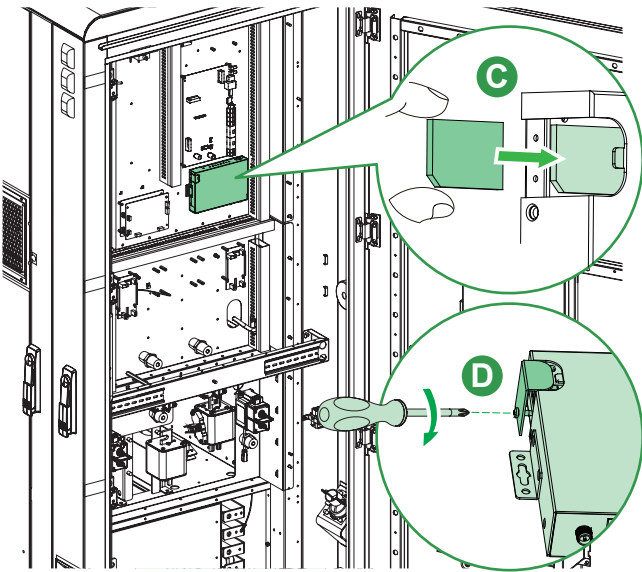

- C** • Carefully insert the SIM Card in the dedicated slot shown in the image.
- D** • Using a small cross screwdriver, reinstall the small red sheet metal and manually tighten the screw.

11 Installation of Power Module

⚠ CAUTION

HAZARD OF EQUIPMENT DAMAGE

The front and rear of the power module must be clear of any obstructions to the ventilation fans flow of air while installed in the Charging Station.
Failure to follow these instructions can result in injury or equipment damage.

NOTE: The power modules are shipped with their address settings set and identified in their addressed order from bottom to top; i.e. A01 in the bottom slot and A06 in the top slot.

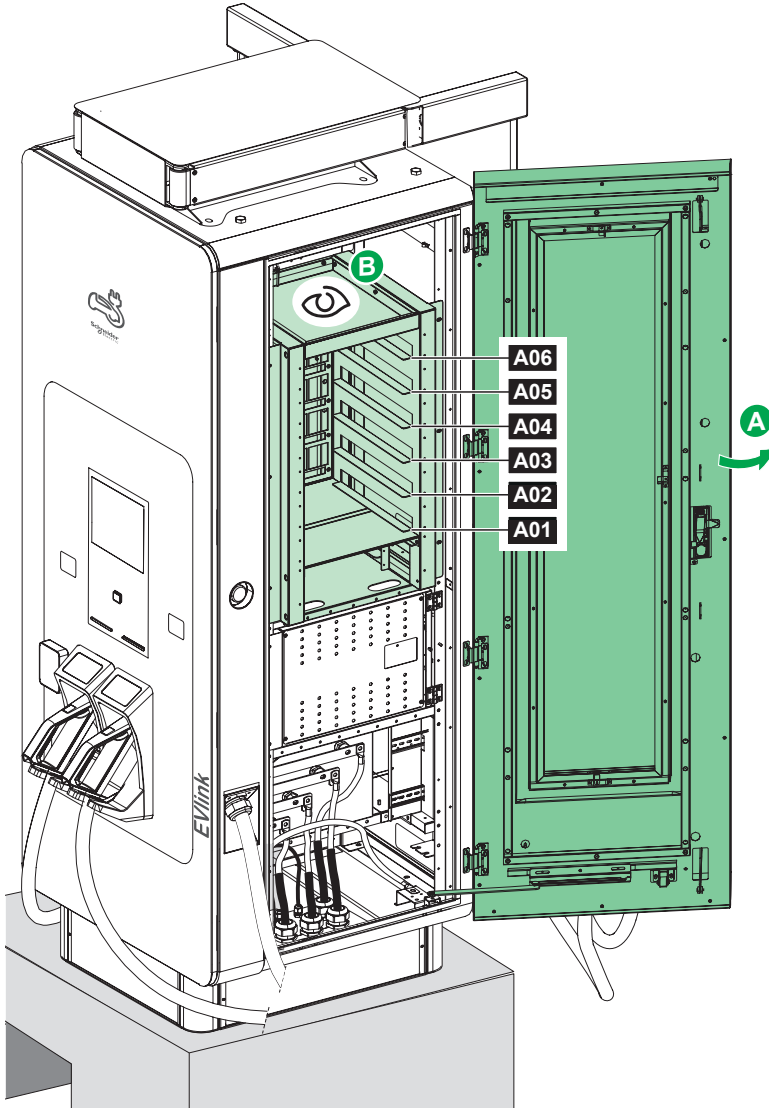
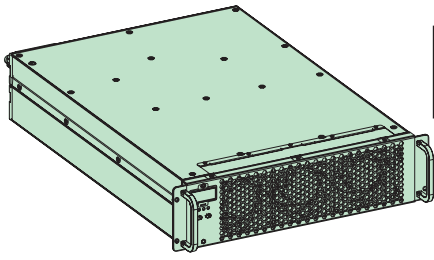

- A • Open the right-hand door of the Charging Station.
- B • Locate the slot in which the power module will be installed.

11 Installation of Power Module

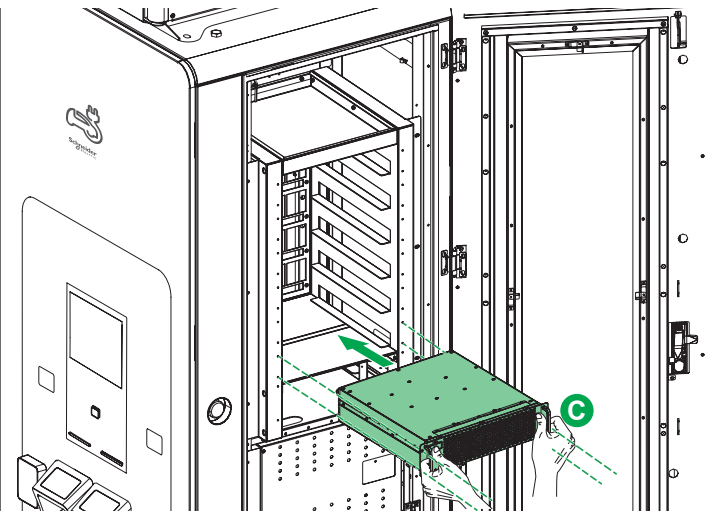

C • Carefully with 2 hands hold the power module using both handles and insert in the available slots.

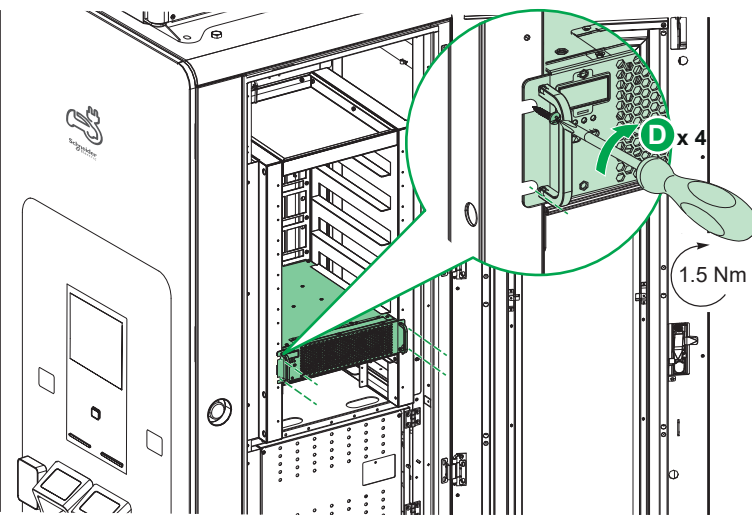

D • Use the 4 provided screws to fix the power module in place.

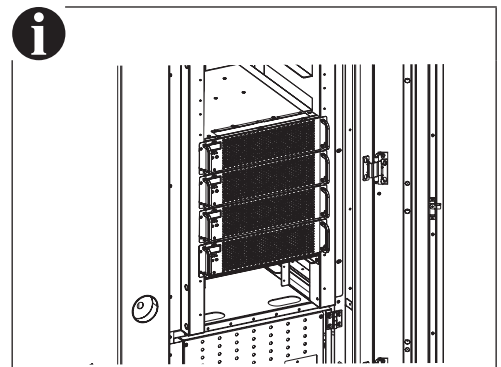

12 Finalization

- Complete the installation checklist (Appendix 1) and ensure any open points are closed before placing it in the document holder inside the charger for verification prior to commissioning.
- Place the provided user guidance sticker on a suitable/visible location on the Charging station. (Optional).

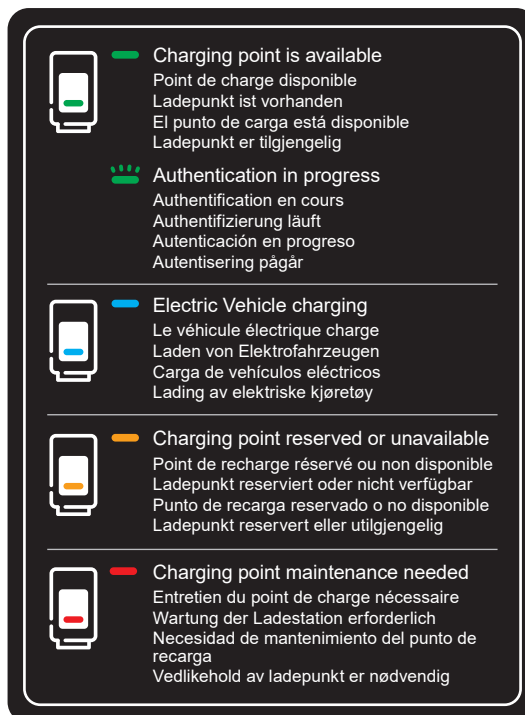

13 Startup / Shutdown

⚠️ ⚠️ DANGER

HAZARD OF ELECTRIC SHOCK, EXPLOSION OR ARC FLASH

- When the system is in an open or dangerous condition, do not allow unqualified persons to go near it. Instruct/warn people about the potential harmful high voltages.
 - Make sure that the main upstream protection switch of the power supply for the product is set to the OFF position. Follow standard **Lock-Out/Tag-Out** before proceeding.
 - Always perform a voltage absence test to confirm that the electrical power is disconnected from the system.
- Failure to follow these instructions will result in death or serious injury.**

13.1 Startup

After completing the installation inspection checklist, you can proceed to **Startup** the charger to test the Power system:

- A** • Keep the upstream circuit breaker in the open (off) position and proceed to close (ON) the QF1 main breaker and QF2 and QF3 MCBs in the Charging Station.
- B** • Close and secure all the Charging Station doors.
- C** • Proceed to close the upstream circuit breaker (ON).
- D** • Wait for 1 minute for the HMI and indicator lights to come online. The HMI screen will display a welcome screen. Verify that there is no error messages and that both indicator lights are stable green.
- E** • Switch off the charger and wait 5 minutes before you proceed to commissioning.

Location of QF1
Front door

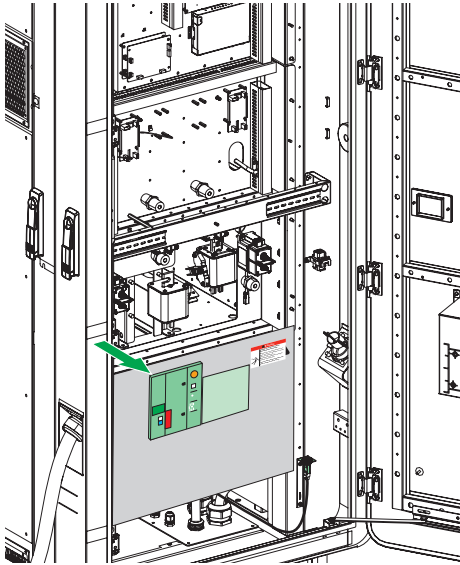

Location of QF2
Right door

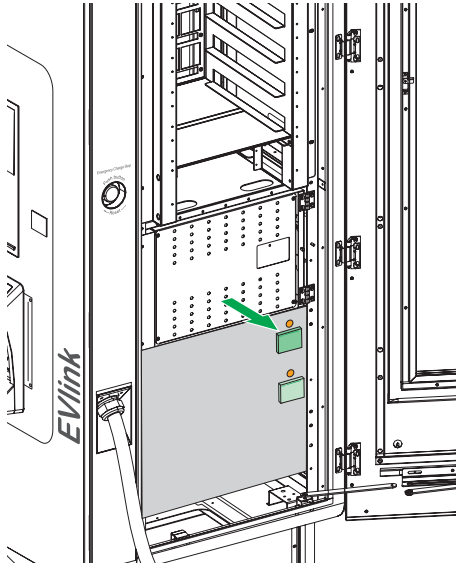

Location of QF3
Right door

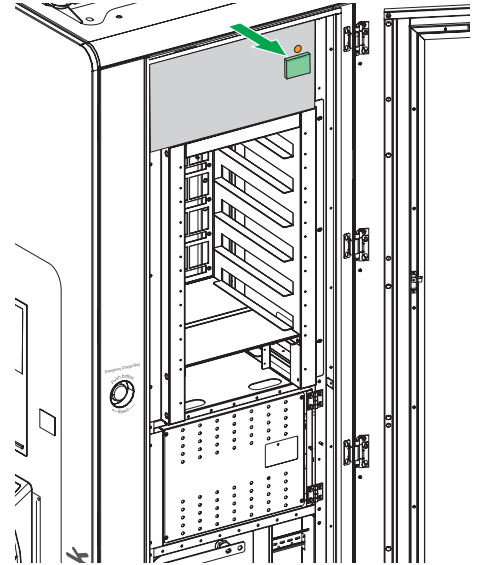

13.2 Shutdown

⚠️ ⚠️ DANGER

HAZARD OF ELECTRIC SHOCK

It is mandatory to wait for 5 minutes after the equipment is disconnected to allow capacitors to discharge before touching any internal parts.

Failure to follow these instructions will result in death or serious injury.

To **shutdown** the system:

- A** • Switch off the QF1 main breaker.
- B** • Switch off the QF3 MCB.
- C** • Switch off the upstream protection breaker.

14 Hide Emergency charge stop button (Optional)

If the emergency charge stop function is not required, peel off the protective film from the adhesive back of the emergency charge stop cover plate, attach it over the emergency charge stop button and its markings. Before attachment, clean the surface with alcohol or an appropriate solvent to remove any oil or dust. Press evenly during attachment to ensure a secure bond.

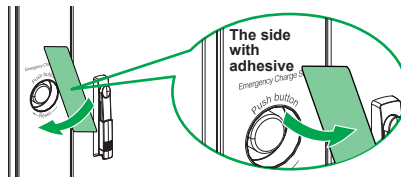

15 Recycle



Product Disposal

To comply with Directive 2012/19/EU of the European Parliament and of the Council of 4 July 2012 on waste electrical and electronic equipment (WEEE), devices marked with this symbol may not be disposed of as part of unsorted domestic waste inside the European Union.

Enquire with local authorities regarding proper disposal.

Product and packaging materials are recyclable as marked.

Appendix 1: Installation Check List

Inspection or Verification	Characteristics	Remarks or Repairs
Structure	Check whether the Charging Station base plates and cable glands are fixed and sealed.	
	Check the Charging Station is well mounted on the concrete foundation and is leveled.	
	Check whether all doors operation and panels are intact, closed and locks are intact.	
	Check that the IP is maintained, gaskets and cable glands secured and no openings permit dust, insects or rodents.	
	Check the necessary space is available for maintenance and all construction work is complete.	
Aesthetic	Check the appearance and cleanliness.	
	Check all signs and notices are clear and intact and remove the protective film from the HMI screen and the safety notices.	
	Check the sealing sticker if mounted on the IP cover (Only for Eichrecht Version).	
Internal components	Verify the QF1 main breaker and QF2 and QF3 MCBs are in switched off position. Position before energizing.	
	Check whether the internal components of the charger are intact. (Removal of internal covers is not required).	
	Visually check for any loose component or wiring.	
	Check for any loose hardware or foreign objects in the bottom of the charger.	
	Verify all grounding cables are secured on all doors and on the bottom of the charger.	
	Verify each power module is screwed in place in its correctly numbered slot.	
Electrical tests	Grounding resistance is $\leq 4\Omega$.	
	Check for over/under voltage.	
Power connections	The specifications of the cables used meet the power requirements of the Charging Station.	
	All power connections (N 1 2 3 and PE) are securely torqued according to the recommended values. (50 Nm).	
	Phase orientation is correct and identified on the cables.	
	Check clearances and creepage distances.	
	No breakage, damage, scratches on cable insulation and all electrical connections and wiring are correct and complete.	
	Check the Charging Cable and connectors are Intact.	
	Check the power module plug in connectors are intact (both upstream and downstream)	
Communication	Ensure that the 4G SIMcard is installed.	
	Ensure that the Ethernet cable is connected to the RJ45 port.	

Verified by:

NOTE: Complete the installation checklist and ensure any open points are closed before placing it in the document holder inside the charger for verification prior to commissioning.

Appendix 2: Charging Station Mounting Template

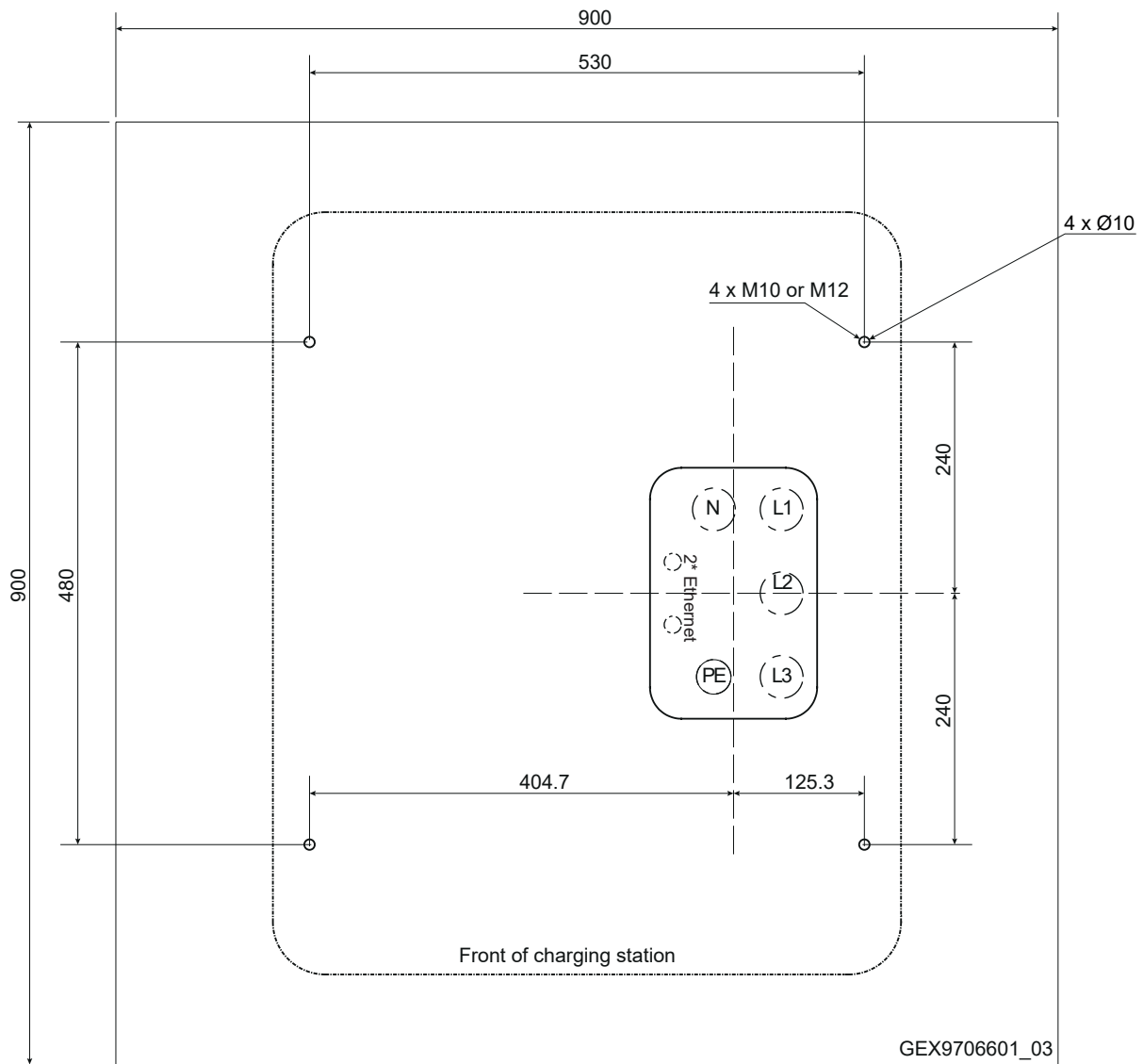

Anhang 3: Schematische Darstellung

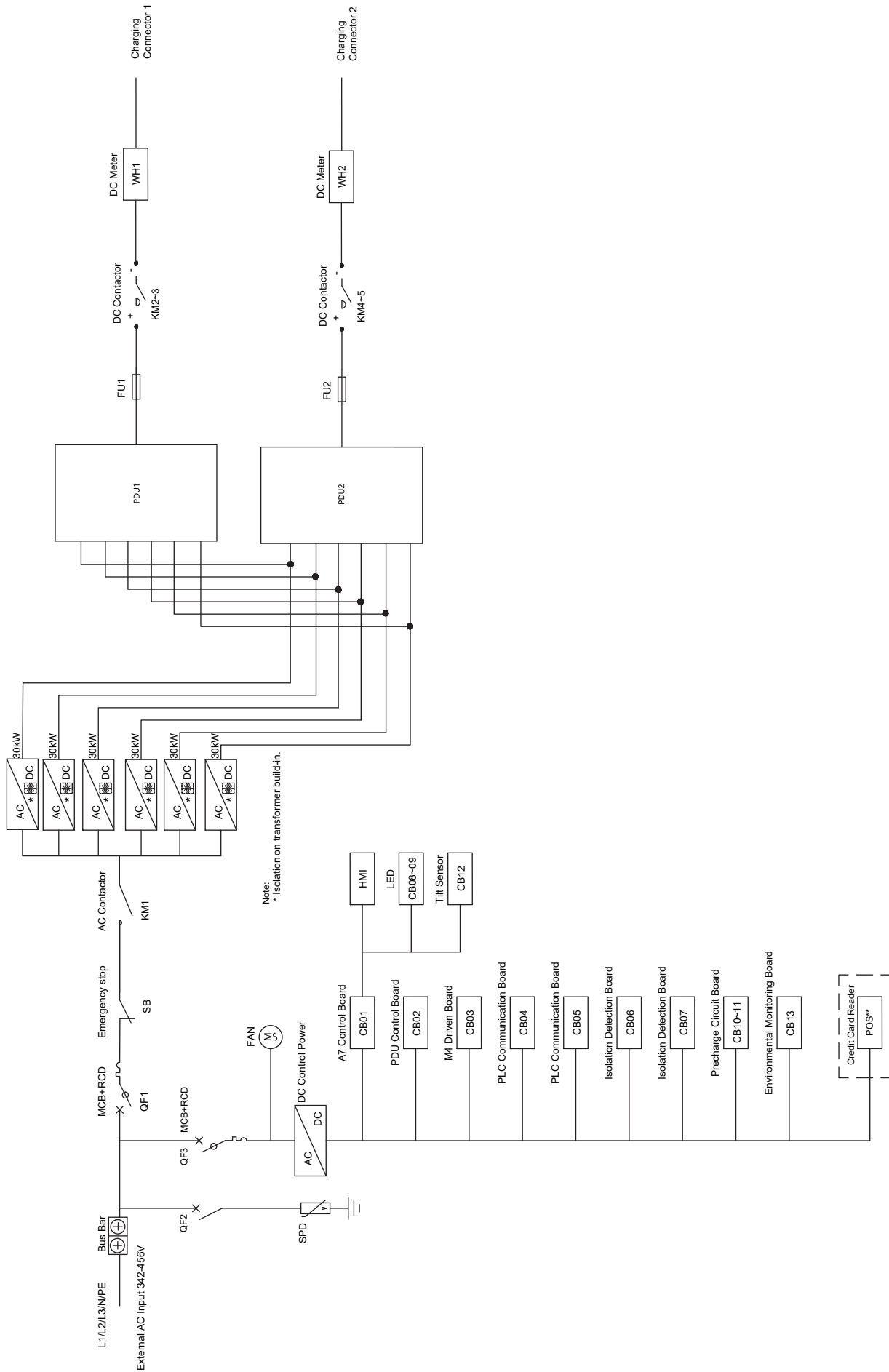

Note:
** For products with embedded credit card reader.

