

SpaceLogic Sensors

SLP Series Air Quality Sensors – BACnet and Modbus



Note: A subset of models shown.

Product Description

The SpaceLogic SLP Series of air quality sensors for living space is a flexible multisensor platform for use with BAS controllers designed to accept BACnet or Modbus outputs. Housings are available in Medium matte white and Optimum faces available in black and white. All housing types are available with three user interface options: touchscreen, LCD with three buttons and blank. CO₂ and temperature sensors are included with all SLP Series air quality sensors. Models with VOC sensors and relative humidity sensors are also available.

Features

- Medium matte white housing or optimum glass panel housing available in white or black
- Field calibratable non-dispersive infrared CO₂ sensor
- Replaceable RH element available in 1% & 2% with NIST certificate
- VOC sensor available
- Temperature output on all models
- 61 mm (2.4") backlit color touchscreen and LCD, three button display options available
 - Digital temperature indication (0.1° display resolution of °F or °C)
 - Digital humidity indication (0.1% RH display resolution)
 - Digital CO₂ indication (1 ppm display resolution)
 - Stoplight feature for visual indication at user-configurable CO₂ threshold levels (touchscreen models only)
 - Selectable temp, RH and fan speed setpoint
 - Configurable screen/button lock and display timeout
 - Override
- Selectable BACnet MSTP and Modbus outputs via RS-485
- 18-24 AWG screw terminals

Available Products

Model Number	Description	User Interface	CO ₂ / VOC	RH*	Housing Finish
SLPBLC2	SLP Prem HSG CO ₂ LCD/3 Button	LCD / 3 Buttons	NDIR CO ₂	2% RH Sensor	Optimum, Black
SLPBLCV2	SLP Prem HSG CO ₂ LCD/3 Button	LCD / 3 Buttons	NDIR CO ₂ / VOC	2% RH Sensor	Optimum, Black
SLPBLCVX	SLP Prem HSG CO ₂ LCD/3 Button	LCD / 3 Buttons	NDIR CO ₂ / VOC	None	Optimum, Black
SLPBLCX	SLP Prem HSG CO ₂ LCD/3 Button	LCD / 3 Buttons	NDIR CO ₂	None	Optimum, Black
SLPBTC2	SLP Prem HSG CO ₂ Touchscreen	Touchscreen	NDIR CO ₂	2% RH Sensor	Optimum, Black
SLPBTCV2	SLP Prem HSG CO ₂ Touchscreen	Touchscreen	NDIR CO ₂ / VOC	2% RH Sensor	Optimum, Black
SLPBTCVX	SLP Prem HSG CO ₂ Touchscreen	Touchscreen	NDIR CO ₂ / VOC	None	Optimum, Black
SLPBTCX	SLP Prem HSG CO ₂ Touchscreen	Touchscreen	NDIR CO ₂	None	Optimum, Black
SLPBXC2	SLP Prem HSG CO ₂ Blank	None	NDIR CO ₂	2% RH Sensor	Optimum, Black
SLPBXCV2	SLP Prem HSG CO ₂ Blank	None	NDIR CO ₂ / VOC	2% RH Sensor	Optimum, Black
SLPBXCX	SLP Prem HSG CO ₂ Blank	None	NDIR CO ₂ / VOC	None	Optimum, Black
SLPBXCX	SLP Prem HSG CO ₂ Blank	None	NDIR CO ₂	None	Optimum, Black

USA: +1 888-444-1311
 Europe: +46 10 478 2000
 Asia: +65 6484 7877
www.schneider-electric.com

Life Is On

Schneider
Electric

Available Products (cont.)

Model Number	Description	User Interface	CO2 / VOC	RH*	Housing Finish
SLPCLC2	SLP CO2 LCD/3 Button	LCD / 3 Buttons	NDIR CO2	2% RH Sensor	Medium, White
SLPCLCV2	SLP CO2 LCD/3 Button	LCD / 3 Buttons	NDIR CO2 / VOC	2% RH Sensor	Medium, White
SLPCLCVX	SLP CO2 LCD/3 Button	LCD / 3 Buttons	NDIR CO2 / VOC	None	Medium, White
SLPCLCX	SLP CO2 LCD/3 Button	LCD / 3 Buttons	NDIR CO2	None	Medium, White
SLPSTC2	SLP CO2 Touchscreen	Touchscreen	NDIR CO2	2% RH Sensor	Medium, White
SLPSTCV2	SLP CO2 Touchscreen	Touchscreen	NDIR CO2 / VOC	2% RH Sensor	Medium, White
SLPSTCVX	SLP CO2 Touchscreen	Touchscreen	NDIR CO2 / VOC	None	Medium, White
SLPSTCX	SLP CO2 Touchscreen	Touchscreen	NDIR CO2	None	Medium, White
SLPSXC2	SLP CO2 Blank	None	NDIR CO2	2% RH Sensor	Medium, White
SLPSXCV2	SLP CO2 Blank	None	NDIR CO2 / VOC	2% RH Sensor	Medium, White
SLPSXCVX	SLP CO2 Blank	None	NDIR CO2 / VOC	None	Medium, White
SLPSXCX	SLP CO2 Blank	None	NDIR CO2	None	Medium, White
SLPWLC2	SLP Prem HSG CO2 LCD/3 Button	LCD / 3 Buttons	NDIR CO2	2% RH Sensor	Optimum, White
SLPWLCV2	SLP Prem HSG CO2 LCD/3 Button	LCD / 3 Buttons	NDIR CO2 / VOC	2% RH Sensor	Optimum, White
SLPWLCVX	SLP Prem HSG CO2 LCD/3 Button	LCD / 3 Buttons	NDIR CO2 / VOC	None	Optimum, White
SLPWLCX	SLP Prem HSG CO2 LCD/3 Button	LCD / 3 Buttons	NDIR CO2	None	Optimum, White
SLPWTC2	SLP Prem HSG CO2 Touchscreen	Touchscreen	NDIR CO2	2% RH Sensor	Optimum, White
SLPWTCV2	SLP Prem HSG CO2 Touchscreen	Touchscreen	NDIR CO2 / VOC	2% RH Sensor	Optimum, White
SLPWTCVX	SLP Prem HSG CO2 Touchscreen	Touchscreen	NDIR CO2 / VOC	None	Optimum, White
SLPWTCX	SLP Prem HSG CO2 Touchscreen	Touchscreen	NDIR CO2	None	Optimum, White
SLPWXC2	SLP Prem HSG CO2 Blank	None	NDIR CO2	2% RH Sensor	Optimum, White
SLPWXCV2	SLP Prem HSG CO2 Blank	None	NDIR CO2 / VOC	2% RH Sensor	Optimum, White
SLPWXCVX	SLP Prem HSG CO2 Blank	None	NDIR CO2 / VOC	None	Optimum, White
SLPWXCX	SLP Prem HSG CO2 Blank	None	NDIR CO2	None	Optimum, White

*Replaceable RH module available to be ordered separately per table below.

Replaceable RH Elements

Model	Description	Temp. Calibration	RH Calibration
SLXRHS2N	Replaceable RH sensor, 2% with NIST certificate	N/A	2-point calibration
SLXRHS2X	Replaceable RH sensor, 2%	N/A	2-point calibration
SLXRHS1N	Replaceable RH sensor, 1% with NIST certificate	N/A	2-point calibration

USA: +1 888-444-1311
 Europe: +46 10 478 2000
 Asia: +65 6484 7877
www.schneider-electric.com

Life Is On

Schneider
Electric

Specifications

Operating Environment			
Input power	Class 2; 20 to 30 Vdc, 24 Vac, 50 to 60 Hz		
Protocol output	BACnet or Modbus via RS-485, selectable		
Operating temp. range	0 to 50 °C (32 to 122 °F)		
Operating humidity range	0 to 95% RH non-condensing		
Housing material	High impact ABS plastic		
IP rating	IP 30		
Mounting location	For indoor use only. Not suitable for wet locations.		
Surface mount	The device can be surface mounted on Single Gang J-Box, British Standard and CE60 wall boxes		
CO ₂ Sensor			
Sensor type	Non-dispersive infrared (NDIR), diffusion sampling		
Output range	0 to 10,000 ppm		
Accuracy	±30 ppm ±3% of measured value		
Repeatability	±20 ppm ±1% of measured value		
Response time	<60 seconds for 90% step change		
VOC Sensor			
Sensor type	Solid state		
Output range	0 to 100% AQI for VOC		
Accuracy	±15% of measured value		
Output scale	0 to 1,000 ppb of total VOC (TVOC)		
AQI table*	Level	Ventilation Recommendation	TVOC (ppb)
	>61%	Greatly increased	>610
	20 to 61%	Significantly increased	200 to 610
	10 to 20%	Slightly increased	100 to 200
	5 to 10%	Average	50 to 100
	0 to 5%	Target value	0 to 50
RH Sensor			
HS sensor	Solid state capacitive, replaceable		
Accuracy (includes hysteresis)**	±3.8% RH from 10 to 60% RH @ 25°C (77 °F) ±4.8% RH from 60 to 80% RH @ 25°C (77 °F) ±5.8% RH from 80 to 100% RH @ 25°C (77 °F)		
Linearity	Included in accuracy specification		
Stability	±1% @ 20°C (68 °F) annually for 2 years		
Output range	0 to 100% RH		
Temperature coefficient	±0.1% RH/°C above or below 25 °C (77 °F) typical		
Temperature Sensor			
Sensor type	Solid state, integrated circuit		
Accuracy	±0.2 °C (±0.4 °F) typical		
Resolution	0.1 °C (0.1 °F)		
Range	0 to 50 °C (32 to 122 °F)		

Display Models	
Touchscreen	61 mm (2.4 in), color, backlit, capacitive, 240x300px Setpoint: Temperature, humidity or fan speed selectable Timeout override: Display timeout Lockout override: Touchscreen/button lockout
	52mm (2.05 in), segmented with 3 buttons Setpoint: Temperature, humidity or fan speed selectable Timeout override: Display timeout Lockout override: Touchscreen/button lockout
LCD	52mm (2.05 in), segmented with 3 buttons Setpoint: Temperature, humidity or fan speed selectable Timeout override: Display timeout Lockout override: Touchscreen/button lockout
Setpoints***	
Temperature setpoint	Scale: 0 to 50 °C (32 to 122 °F) max., adjustable span
Humidity setpoint	Scale: 0 to 100% RH
Fan speed setpoint	Off, Low, Medium, High, Auto
Override	
Override button	Display models feature momentary override button
Wiring Terminals	
Terminal blocks	Screw terminals, 18-24 AWG
Screw terminal torque	0.2 N-m (2.0 in-lbF) max.
Regulatory Information	
Agency approvals	UL 916 European Conformance CE: EN 60730-1, EN 60730-2-9, EN 60730-2-13, EN 61000-6-2, EN 61000-6-3, EN 61000 Series - Industrial Immunity, EN 61326-1 FCC Part 15 Class B, REACH, RoHS, Green Premium, RCM (Australia), ICES-003 (Canada), EAC (Russia), UKCA (UK)

*Air Quality Index for VOC aligns with TVOC levels for IAQ as specified by the WHO (World Health Organization).

**Humidity sensor overall accuracy should include: accuracy, temperature coefficient and stability. Humidity accuracy is shown as an absolute value, so if testing accuracy with a hand-held device, you must check for deviation in its readings instead of calculating the percentual deviation. Additionally, you must consider the overall accuracy of the hand-held device in the comparison.

***On display models only.

USA: +1 888-444-1311
Europe: +46 10 478 2000
Asia: +65 6484 7877
www.schneider-electric.com

Life Is On

Schneider
Electric

Dimensions mm (in.)

Optimum Housing

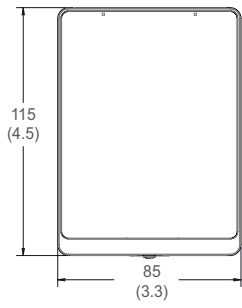

Medium Housing

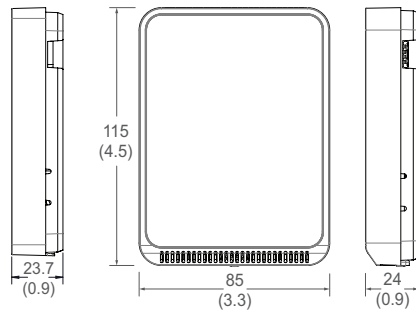

Housing Finishes



Optimum White



Optimum Black



Medium White

User Interface Types



Touchscreen



LCD with Buttons



Blank

Power Table

Model	Description	Max. VA
SLPxLCxx	LCD CO2/VOC/Temperature/Humidity	1.536
SLPxTCxx	Touch CO2/VOC/Temperature/Humidity	1.728
SLPxXCxx	Blank CO2/VOC/Temperature/Humidity	1.536

Note: Model numbers based on supported product matrix.