

# SpaceLogic MP2000

Multi-Signal Control Actuators for VP221x  
SpaceLogic PIBCV, DN125-150 (5" and 6")



## Product Description

MP2000 actuator is used with pressure independent balancing and control large valve type **SpaceLogic** PIBCV DN 125 and DN 150 (5" and 6").

The actuator automatically adapts its stroke to valve end positions to reduce commissioning time.

## Features

- The advanced design incorporates load related 'switch-off' to ensure that actuators and valves are not exposed to overload.
- The advanced design incorporates a diagnostic LED, operational data capture and self-stroking feature.
- Manual override.

## Specifications

Part Number	MP2000
Power supply	24 Vac, +10 ... -15%
Power consumption	9 VA
Frequency	50 / 60 Hz
Control signal input	Modulating and 3 Point floating
Control input Y	0 ... 10 V (2 ... 10) Ri = 24 kΩ 0 ... 20 mA (4 ... 20) Ri = 500 Ω
Output signal X	0 ... 10 V (2 ... 10)
Close of force	2000 N (449.62 lbf)
Max. stroke	40 mm (1½")
Speed	8 s/mm
Max. medium temperature	200 °C (392 °F)
Ambient temperature	0...55 °C (0...131 °F)
Storage and transport temperature	-40 ... +70 °C (-40...158 °F)
Protection class	III safety extra-low voltage
Degree of protection	IP 54
Weight	3.8 kg (8.38 lbs)
Standards/Directives	
ElectroMagnetic Compatability [EMC]	2014/30/EU
Low voltage directive [LVD]	2014/35/EU
Restr. of Hazardous Substances [RoHS2]	2011/65/EC
Heat	IEC 60068-2-2
Humidity	IEC 60068-2-3
Cold	IEC 60068-2-1
Vibration	IEC 60068-2-6

Underwriters Laboratory (E9429) cULus LISTED compliance as Temperature Indicating & Regulatory Equipment per UL873 and Canadian Standard C22.2 No. 24.

## Dimensions (mm)

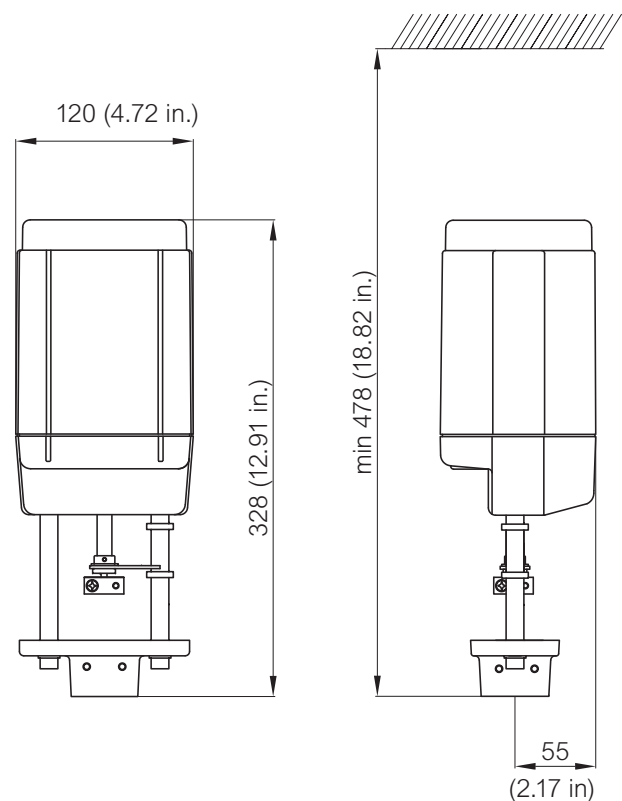

## Mounting and Installation

The actuator should be mounted with the valve stem in either horizontal position or pointing upwards. Use a 4 mm Allen key (not supplied) to fit the actuator to the valve body. Allow for necessary clearance for maintenance purposes. The valve has position indication rings which should be pushed together before commissioning; after stroking they indicate the ends of the stroke.

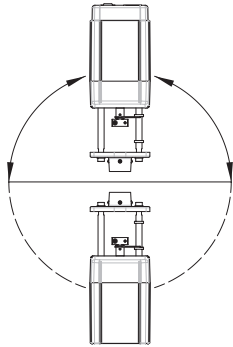

### Automatic Self-Stroking Feature

When power is first applied, the actuator will automatically adjust to the length of the valve stroke. Subsequently, the self-stroking feature can be re-initialised by changing position of SW9.

### Diagnostic LED

The red diagnostic LED is located on the pcb under the cover. It provides indication of three operational states: Actuator Healthy (Permanently ON), Self-stroking (Flashes once per second), Error (Flashes 3 times per second - seek technical assistance).

### Commissioning

Complete the mechanical and electrical installation and perform the necessary checks and tests:

- Isolate control medium (e.g. self-stroking in a steam application without suitable mechanical isolation could cause a hazard).
- Apply the power. Note that the actuator will now perform the self-stroking function.
- Apply the appropriate control signal and check the valve stem direction is correct for the application.
- Ensure that the actuator drives the valve over its full stroke, by applying the appropriate control signal. This action will set the valve stroke length. The unit is now fully commissioned.

### Commissioning / Testing feature

Under proportional control, the actuator can be driven to the fully open or closed positions by connecting the 0V supply on terminal SN (-24) to terminals Y1 or Y2.

**NOTICE**

**RISK OF EQUIPMENT DAMAGE**

- Avoid electrical noise interference.
- Do not install near large contactors, electrical machinery, or welding equipment.
- Only use manual override when power is off.

**Failure to follow these instructions may result in damage to the gear train or other mechanical damage.**

## Manual Override

The manual override is applied by rotating the 4 mm Allen key (not supplied) to the required position. Observe the direction of the rotation symbol.

- Disconnect power supply
- Adjust valve position using an Allen key
- Set valve to closed position
- Restore power supply

If manual override has been used then the actuator position against the U and Y signal is not correct until the actuator reaches its end position. If this is not desired reset the actuator.

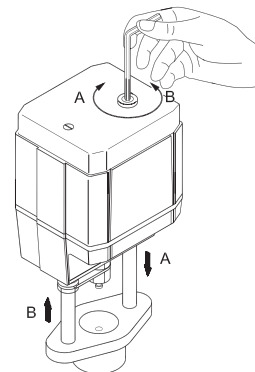

## Wiring and Connections

Electrical connections can be accessed by removing the cover. Two M16 x 1.5 cable entries are provided. Both entries are provided with a rubber grommet for use with flexible cable. Note that in order to maintain the enclosure IP rating, appropriate cable glands must be used.

Wiring for modulating control

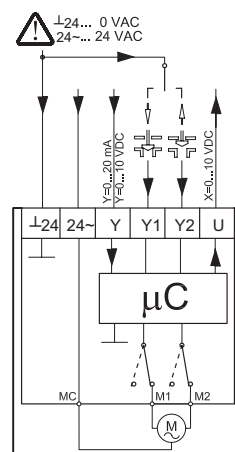

Wiring for 3-point control

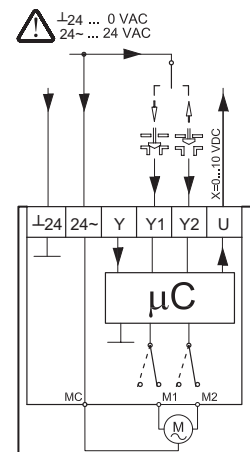

Note: If switch SW6 is set to ON for 3 point floating control, then use this wiring.

Wiring length	Recommended square of the wiring
0 - 50 m	0.75 mm <sup>2</sup>
> 50 m	1.5 mm <sup>2</sup>

- 24~ 24 V~ Power supply
- ⊥24 0 V Common
- Y 0 to 10 V Input signal (2 to 10 V)  
0 to 20 mA (4 to 20 mA)
- U 0 to 10 V Output signal (2 to 10 V)

## DIP Switch Settings

The actuator has a function selection DIP switch under the removable cover.

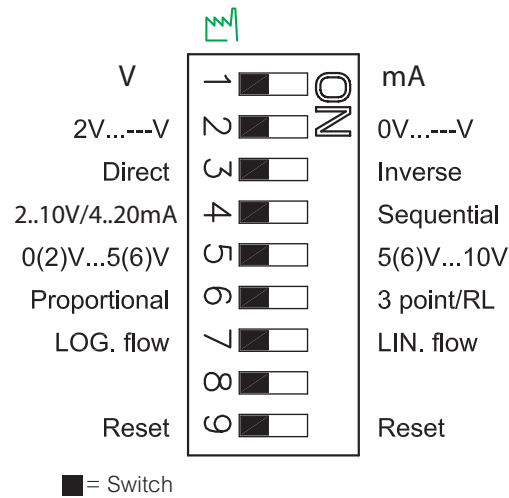

- SW1: V/mA - Input signal type**
  - OFF position, voltage input is selected.
  - ON position, current input is selected.
- SW2: 0...10/2...10V(0...20/4...20mA) - Input signal range**
  - OFF position, the input signal is in the range from 2 V...10 V (voltage input) or from 4 mA...20 mA (current input).
  - ON position, the input signal is in the range from 0 V...10 V (voltage input) or from 0 mA...20 mA (current input).
- SW3: D/I - Direct or inverse acting**
  - OFF position, the actuator is direct acting (stem retracts upwards as voltage increases).
  - ON position, the actuator is inverse acting (stem extends downwards as voltage increases).
- SW4: - - -/Seq - Normal or sequential mode**
  - OFF position, the actuator is working in range 0(2)...10V or 0(4)...20mA.
  - ON position, the actuator is working in sequential range; 0(2)...5 (6)V or 0(4)...10 (12)mA) or (5(6)...10V) or (10(12)...20mA).
- SW5: 0...5V/5...10V - Input signal range in sequential mode:**
  - OFF: Actuator is working in sequential range: 0(2)...5 (6)V or 0(4)...10 (12)mA.
  - ON: Actuator is working in sequential range: 5(6)...10V or 10(12)...20mA.
- SW6: Prop./3-point - Modulating or 3-point mode**
  - OFF position, the actuator is working normally according to control signal.
  - ON position, the actuator is working as 3-point actuator.
  - With SW6 ON all other switches are inactive.
- SW7: LOG/LIN Electronic flow curve adaptation:**
  - OFF: EQ% flow
  - ON: Linear Flow
- SW8: reduced stroke**
  - Set to OFF; function not to be used on **SpaceLogic** PIBCV.
- SW9: Reset:**
  - Changing this switch position will initiate stroke calibration.

