

SpaceLogic MP500C-SRU/SRD

Multi-Signal Spring Return Actuators for
SpaceLogic PIBCV VP220x, DN40...100
(1½...4")

Product Description

MP500C-xxx is a linear electro-mechanical actuator with spring return function in the event of a power failure for use with the VP220x **SpaceLogic** PIBCV, in the sizes DN40...100.

MP500C, MP500C-SRU/SRD and "W" versions are controlled by either an increase/decrease floating signal or by a range of modulating control signals between the span of 0...10V.

The IP65 (NEMA 4) versions with suffix -W of the MP500C-SRU/SRD, are designed to be mechanically robust such that they can be used in outdoor applications, including rooftops.

Specifications

MP500C	Non-Spring Return
MP500C-SRU (-W)	Stem up (retract)
MP500C-SRD (-W)	Stem down (extend)
Voltage supply	24 Vac ±20% 50-60Hz 24 Vdc ±20%
Transformer Sizing	50 VA
Power consumption	
Running	30 VA (21 W)
Rest	7 W
MP500C	average 15 VA
Running Time	
Modulating	15 sec.
Increase/decrease (selectable)	60/300 sec.
Spring return	13 sec.
Stroke	2...35 mm
Force, nominal	500 N
Duty cycle	
Full load, high amb. temp.	20%/60 minutes
Half load, room temp.	80%/60 min.
Analog input Voltage range (selectable)	0...10, 2...10, 0...5, 2...6, 5...10, 6...10 Vdc
Impedance	Min. 100 k Ohm
Digital inputs, Y1, Y2	
Voltage across open input	24 Vac
Current through closed input	5 mA
Pulse time	min. 20 ms
Output, U	
Position Feedback	2...10 or 0...5 Vdc (0-100%)
Load	2 mA
Environmental	
Operation Temperature	14...122°F (-10...50 °C)
Storage Temperature	-13...149°F (-25...65 °C)
Ambient Humidity	max 90% RH (non-condensing)
Sound power level NSR	32 dBa
SR	43 dBa



MP500C



MP500C-SRU/SRD

Features

- Brushless DC motor.
- High resolution control board allows precise fluid control.
- Working range and end point switches adjusted automatically to the stroke of the valve.
- When driven electrically, firmware calibrates a consistent running time regardless of the valve stroke.
- On power loss the mechanical spring return drives the motor, giving power to the board to control spring return braking, avoiding mechanical stress and water hammer.
- Can be configured for either 3 point increase/decrease signal or various modulating control signals including sequencing.
- The U-Bolt connection allows quick and easy direct mounting onto the **SpaceLogic** PIBCV VP220 valves.

Enclosure rating	
MP500C, MP500C-SRU, MP500C-SRD	IP54 (NEMA 2)
MP500C-SRU-W, MP500C-SRD-W	IP65 (NEMA 4)
Standards/Directives	
ElectroMagnetic Compatability [EMC]	2014/30/EU
Low voltage directive [LVD]	2014/35/EU
Restriction of Hazardous Substances [RoHS2]	2011/65/EC
Heat	IEC 60068-2-2
Humidity	IEC 60068-2-3
Cold	IEC 60068-2-1
Vibration	IEC 60068-2-6
Weight	3.2 Kg
Materials of Construction; Housing and Cover	Aluminum
Max cable core diameter	2.5 mm ²
Wiring Entry: Conduit connection	4 x M20 capped holes
Cable gland	1 x 6..12 mm O/D, IP68
Direct connection to Smart X PIBCV valves VP220	DN40...100
S2 Auxillary Switch Relay (optional accessory)	SPDT, 24 Vac (contacts made at 5% and 95% of end stroke)
	4A AC1

Part Numbers & Accessories

Part Number	Spring Return Direction	On Power Failure	Rating
MP500C	Non-Spring Return Actuator		NEMA 2
MP500C-SRU	Spring return stem up	Valve Open	
MP500C-SRD	Spring return stem down	Valve Closed	NEMA 4
MP500C-SRU-W	Spring return stem up	Valve Open	
MP500C-SRD-W	Spring return stem down	Valve Closed	
880 0104 000	S2 aux end point switches		

Dimensions mm (inches)

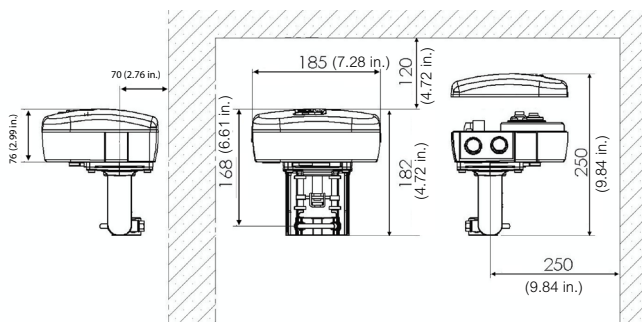

Function

The actuator utilizes a brushless DC motor to accurately position the main spindle via a gearbox depending on the control signal received from the controller. Upon initial start up the and self stroking activation (operation of switch 9) the actuator performs a full stroke cycle to learn the valve end stop positions and to calibrate the motor speed and actuator full stroke running time. End switch point adjustment is also calibrated during this process. In case of power failure the actuator is equipped with spring return function which returns the valve and actuator back to the rest position. The actuator cannot be configured or modified between spring return stem up and spring return stem down.

Control Signal

MP500C-SRU/SRD and -W actuators can either be controlled by an increase/decrease signal or by a variable direct voltage. The actuator is very flexible regarding the configuration of signal input and a direct or inverse actuation but normally for an increase/decrease the actuator retracts (moves up) on an increase signal and extends (moves down) on a decrease signal.

Spring Pretension

To ensure tight shut off from an assembled SR actuator and control valve for closure on spring return function, it is necessary during installation to align the actuator spindle with the required valve stroke and stroke limits. Refer to Installation Instructions F-27943.

Position Feedback

MP500C-SRU/SRD and -W actuators are equipped with a 2...10 Vdc and 0...5 Vdc position feedback signal selectable by Sw 1.

End Point Switch (Accessory)

When fitted, the End Point Switch (S2 Auxiliary Switch relay) is calibrated during the initial stroke learning procedure. The switch points electronically make at 5% and 95% of the calibrated stroke position. When actuators are controlled in normal or sequence control it is possible to use the end point switches to drive other equipment or to signal if the valve is fully open or fully closed.

Maintenance

The actuator does not require any maintenance.

Agency Listings

Underwriters Laboratory (E9429) compliance as Temperature Indicating & Regulatory Equipment cULus LISTED per UL873 and Canadian Standard C22.2 No. 24. Australian/New Zealand community RCM mark.

Mounting and Installation

Note the presence of an O-ring in the cover of the actuator and ensure it is in position as the cover is removed and replaced. The actuator may be mounted in any position other than upside down.

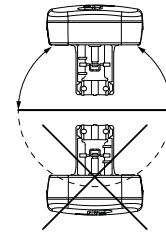

Maximum actuator ambient temperature is 50 °C (122 °F) for chilled water media. Maximum actuator ambient temperature is 46° C (115° F) when media temperature is 120° C (248° F).

To mount the actuator to a valve, first slide the Actuator Crossbeam Coupler into position on the actuator cross beam bracket. Separately, slide the Valve Stem Coupler onto the Valve Stem. Maintaining the couplers in their positions, slide the actuator onto the valve stem then slide the U-bolt into the actuator groove on the valve neck, securing with nuts provided. Driving the crossbeam coupler down into the valve coupler completes the installation and a “click” sound may be heard as the Valve Coupler locking ring engages the Actuator Crossbeam Coupler.

Manual Operation

To operate the manual override power to the actuator must be disconnected. The manual override procedure allows the actuator to be positioned independently of control signal and can be operated with or without the cover attached. The operating direction of both the manual override and lock screw are clearly labelled on both the cover and inside the actuator, and these labels differ based on if the actuator is purchased SRU or SRD. Manual override is conducted by using a 5mm hex (Allen) key either S-shaped, L-shaped or T-shaped tool. The action of the manual override is always against the spring tension. The actuator spindle position can be locked against the spring by twisting the lock screw in the direction as shown on the actuator. The manual override lock should only be released either by nudging the manual override by 10° in the normal direction (against the spring), or re-applying power/control signal to the actuator. When the actuator is first powered on it will momentarily drive against the spring to release the manual override lock before being driven by an external control signal. If the hex key is left in the hex manual override drive socket, the hex key will rotate as the actuator is driven. This is not recommended and damage could occur if the key is not free to rotate.

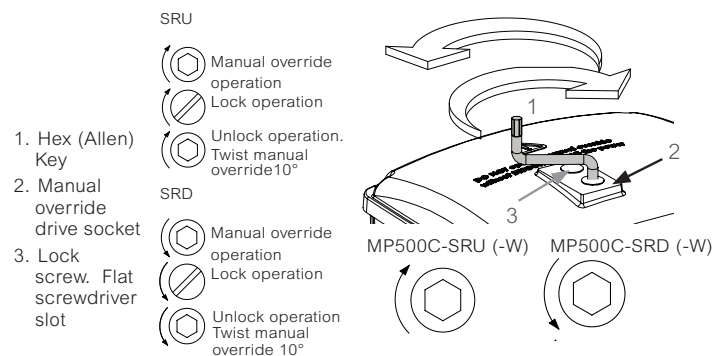

Electrical Connections

Terminal	Function	Description
24~	24 Vac/dc	Supply voltage
⊥24	Ground	
Y	Input	Modulating Control signal
M	Input, neutral	
Y2	Increase	3-point Floating/Digital input control (Y1, Y2 connected to ⊥24)
Y1	Decrease	
U	0...100% (2...10 Vdc)	Feedback signal (reference to ⊥24)

Cable Lengths

24~, ⊥24= Max 100 m, 1.5 mm² (AWG 15)
 Y, M, Y, Y1, Y1 = Max 200 m 0.5 mm² (AWG 20)

NOTE: When installed with 3 conductors, where the control signal reference is connected to ⊥24, the motor current of the actuator will cause varying voltage loss in the cable and thus in the reference level. The MP500C-SRU/SRD and -W have a highly sensitive control circuitry which can be influenced by interference in the control signal which the actuator can try to follow. This influence may be reduced in simple installations by shortening the cable lengths below 100m and /or increasing the cross sectional area of the cable above 1.5mm² (AWG 16) and the cables are spured to only one actuator.

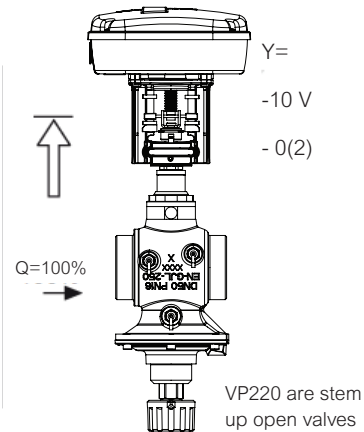

Wiring Examples

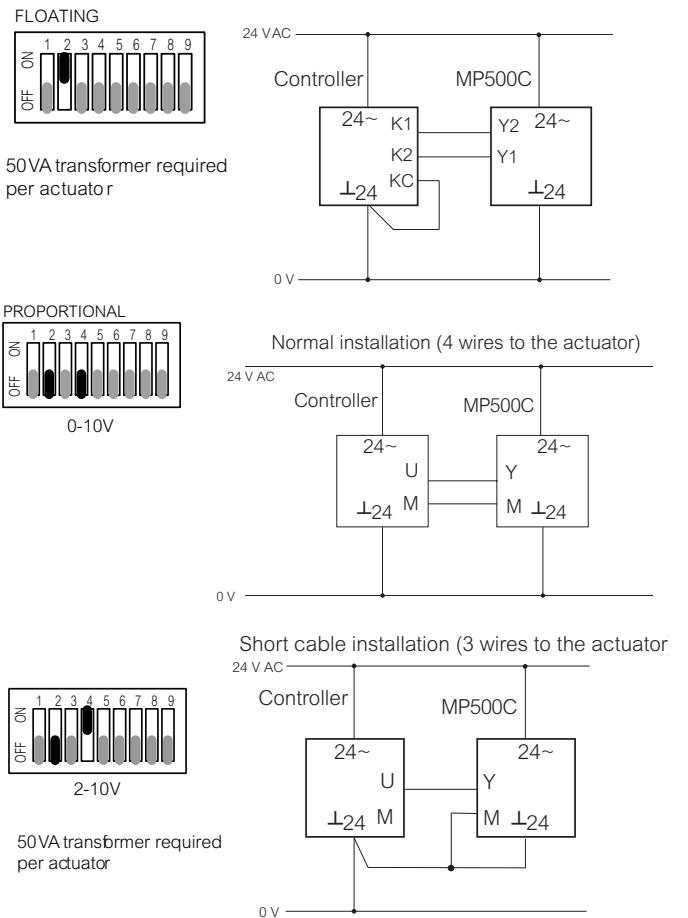

Connections/PCB Layout

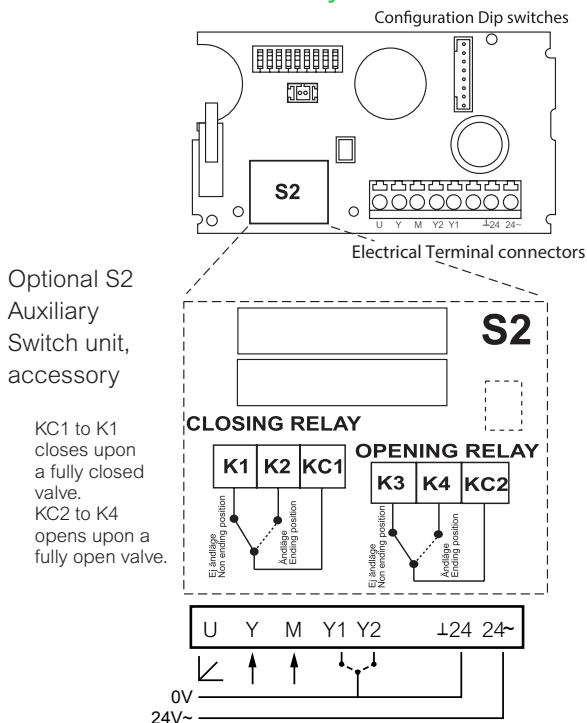

Direction of operation according to Switch 7 Inverse/Normal Operation

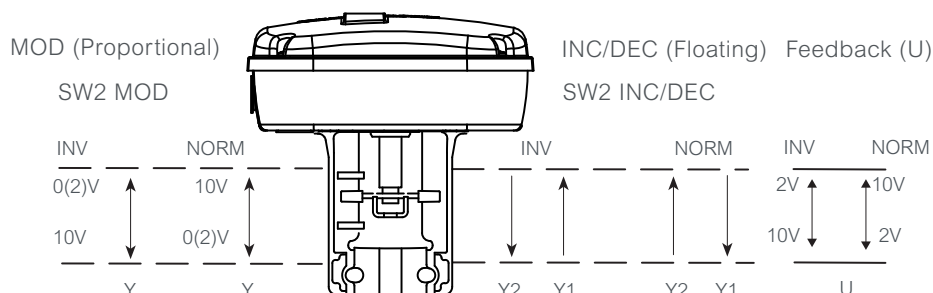

Dip Switch Settings

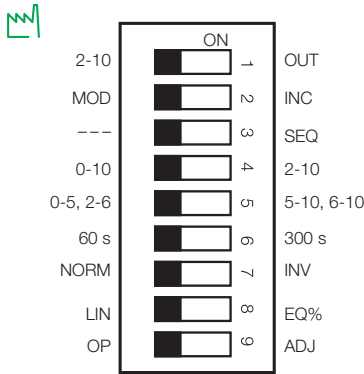

Fig 6 ■ = switch position

Sw	Description	Off Position	On Position
1	Feedback signal	2...10 Vdc	0...5 Vdc
2	Control mode	Modulating (proportional) signal	Increase / Decrease (Floating signal)
3	Sequence operation	--- Normal operation (no sequencing)	SEQ. SW 2 off, SW 3 on, SW 4 select base range (0...10 or 2...10) SW 5 select sequence range.
4	Input voltage range	0...10 Vdc	2...10 Vdc
5	Operational Working voltage range (if SW3, SEQ selected)	0...5 Vdc or 2...6 Vdc	5...10 Vdc or 6...10 Vdc
6	Running time (increase/decrease control only)	60 sec.	300 sec.
7	Direction of movement	NORM. Actuator spindle extends downwards with a decreasing control signal. (Normal operation for VP220x PIBCV)	INV. Actuator spindle retracts upwards with a decreasing control signal
8	Linearization	Linear Flow (Normal)	EQ
9	Stroke Calibration	OP (Normal operation)	ADJ. Calibrate valve stroke limits

There is a 9 switch configuration block on the circuit board. The factory setting is all switches in the "OFF" position. Adjust these settings prior to engaging power and any subsequent changes to the DIP switches will not be registered until the power is interrupted, or when switch No. 9 is initiated (End position adjustment) causing a re-calibration of the actuator and valve assembly.

1 Feedback signal

Select between 2...10 V and 0...5 V feedback voltage output.

2 Control signal MOD / INC.

MP500C-SRU/SRD and -W are either controlled by a variable direct voltage, for a modulating signal (MOD), or by a 3-point increase/decrease signal (INC).

3 Sequence or parallel control – / SEQ.

With sequence (or parallel) control (SEQ), two actuators/valves can be controlled by only one control signal. Depending on Switch 4 and 5, you can choose which part of the voltage range to use, the upper one, 5...10 V (6...10 V) or the lower one, 0...5 V (2...6 V). Note: If sequence or parallel control is not used, the switch --- / SEQ must be in the OFF position.

4 Input Voltage range 0...10 / 2...10.

You can choose whether to use the control signal voltage range 0...10 V or 2...10 V.

5 (0...5, 2...6 / 5...10, 6...10).

When switch 3 (SEQ) is ON choose the operational voltage range.

- OFF: low: 0...5 V (2...6 V)
- ON: high: 5...10 V (6...10 V)

The bracketed control voltage is operational with switch 4 ON.

6 Running time 60 s / 300 s. On increase/decrease control, this switch selects the running time between 60 s (Off) or 300 s (On). With modulating control, the running time is always 15 s.

7 Direction of movement NORM / INV.

The Norm / INV switch reverses the actuator direction of

movement relative to signal change.

- With the switch in the NORM position, the actuator spindle moves down when the signal decreases, this closes the VP220x on a 0V control signal).
- With the switch in the INV, the actuator spindle moves up when the signal decreases. Thus on the VP220x valve, this setting will provide an open valve on 0V control signal).

8 Linearization LIN/EQ.

The motorized valve characteristics can be modified. The setting LIN/EQ will make the VP220x Valve from a linear flow characteristics to an equal percentage.

9 Input signal and stroke Calibration OP / ADJ.

This switch is only used to calibrate the stroke end positions.

To initiate, momentarily move the switch to the ON position then back to the OFF position. At the end of the adjustment all the other dip switch settings (1 to 8) will be registered again.

Commercial Reference	Range Name		Product Description				
880XXXXXXX MXXX(X)A(X)(X)(-S2)(-VB) MGXXX(-S(R)X)(-W) MPXXXX(-SRX)(-W)	SPACELOGIC VALVES & ACTUATORS		SPACELOGIC 800 SERIES GLOBE VALVE ACTUATOR SR/NSR SPACELOGIC M SERIES GLOBE VALVE ACTUATOR SR/NSR SPACELOGIC MG SERIES GLOBE VALVE ACTUATOR SR/NSR SPACELOGIC MP SERIES PIBCV ACTUATOR SR/NSR				
有害物质 - Hazardous Substances							
部件名称 Part Name	铅 (Pb)	汞 (Hg)	镉 (Cd)	六价铬 (Cr(VI))	多溴联苯 (PBB)	多溴二苯醚 (PBDE)	
属部件 Metal Parts	X	O	O	O	O	O	
塑料部件 Plastic Parts	O	O	O	O	O	O	
电子件 Electronic	X	O	O	O	O	O	
触点 Contacts	O	O	O	O	O	O	
线缆和线缆附件 Cable & Cabling Accessories	O	O	O	O	O	O	
<p>本表格依据 SJ/T11364 的规定编制。 O: 表示该有害物质在该部件所有均质材料中的含量均在 GB/T 26572 规定的限量要求以下。 X: 表示该有害物质至少在该部件的某一均质材料中的含量超出 GB/T 26572 规定的限量要求。 (企业可在此处, 根据实际情况对上表中打 "X" 的技术原因进行进一步说明。)</p> <p>This table is made according to SJ/T 11364. O: indicates that the concentration of hazardous substance in all of the homogeneous materials for this part is below the limit as stipulated in GB/T 26572. X: indicates that concentration of hazardous substance in at least one of the homogeneous materials used for this part is above the limit as stipulated in GB/T 26572</p>							