

SpaceLogic VB601R Valve and MB10 Actuator

Motorized 6-port Ball Valve and 2-Position Actuator



Product Description

The VB601R is a 6-port motorized ball valve that performs a diverting function between two water circuits in 4-pipe changeover system. The VB601R valve will switch between heating and cooling with the fitted **SpaceLogic** MB10 two-position rotary actuator.

Flow regulation is provided from an additional **SpaceLogic** PIBCV valve and MP130 / MP300 actuator. This provides the additional benefit of having a balanced energy efficient solution with superb proportional control.

A single on/off control signal to the MB10 6-port diverting valve actuator determines the direction of flow through the valve. Changing the control signal will rotate the actuator and switch the supply ports between heating and cooling

or vice versa. During the 6-port valve motorization, the valve rotates through a mid point with all ports isolated and with no possibility to cross connect and mix the heating and cooling circuits.

Features:

- No cross-flow between supply circuits.
- Single on/off control signal to changeoversupply circuits.
- Visual indication of actual valve position.
- Silent and reliable operation.
- Maintenance free.
- Teflon seal and polished chrome valve ball to prevent valve sticking.
- Manual override.

Specifications

Valve

DN	15	20
Diff Pressure	3.6 (kPa)	14 (kPa)
	at Q Nom of 450 l/h DN15-STD Flow	Q Nom of 900 l/h DN20-STD Flow
	SpaceLogic PIBCV	SpaceLogic PIBCV
Kvs	2.4 (m ³ /h)	4.0 (m ³ /h)
Pressure Class, PN	16	16
Medium Temp.	0 ... 90 (°C)	
Shut off	800 (kPa) ²⁾	
Valve neck	Quick fix connection	
Connection	Internal thread Rp 1/2 ISO 7/1	
Certifications	PED directive 97/23/EC (Art. 3§3)	
Weight	1140 (g)	
Materials: Body and connection	CW 602 N (DZR Brass)	
Ball	CW 614 N Chrome plated	
Stem	CW 614 N Nickel plated	
Seals	P.T.F.E. (TEFLON)	
O-ring	70 EPDM 281	

Actuator

Power supply	24 AC ± 20% (V)
Operating power consumption	5 (VA) (only when running)
Frequency	50/60 (Hz)
Running speed	80 (sec/90°)
Control input	2-point
Operating torque	10 (Nm)
Rotation angle	90 °
Ambient temperature	0 ... 55 (°C)
Storage and transport temperature	-10 ... 80 (°C)
Protection Class	II according to EN 60730-1
Grade of enclosure	IP42 according to EN 60529
Weight	405 (g)
Connection cable (halogen free)	1.5 (m) 3×0.5 (mm ²)
Applied standards:	EN 60730
CE marking in accordance with standards	Low Voltage Directive EMC-Directive RoHS II: 2011/65/EU

Installation and Mounting

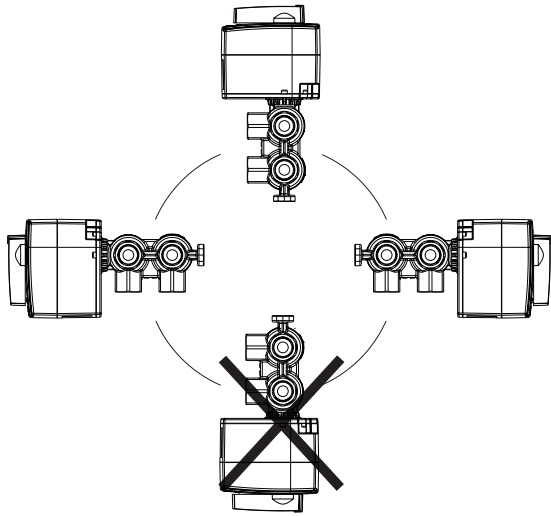

Design flow setting for heating and cooling

(in case of using only one **SpaceLogic** PIBCV as shown)

The design flow needed for heating is generally less than for cooling. Actuator MP130 supports this difference by proportionately limiting the control voltage with a linear characteristic.

Example:

- **SpaceLogic** PIBCV DN15 factory setting 100% = 450 l/h
- Cooling: - VB601R set to cooling - control signal 0 V,
 - PIBCV max. flow demand to terminal unit ~400 l/h = 90% presetting of **SpaceLogic** PIBCV DN15
 - Control signal to MP130 = 0 - 10 V
- Heating: - VB601R set to heating - control signal 24 V,
 - PIBCV max. flow demand to terminal unit ~200 l/h (=44% of **SpaceLogic** PIBCV DN15 flow), presetting of **SpaceLogic** PIBCV DN15 equal to cooling, needed design flow achieved by voltage limitation on MP130.
 - Control signal to MP130 = 0 - 5 V

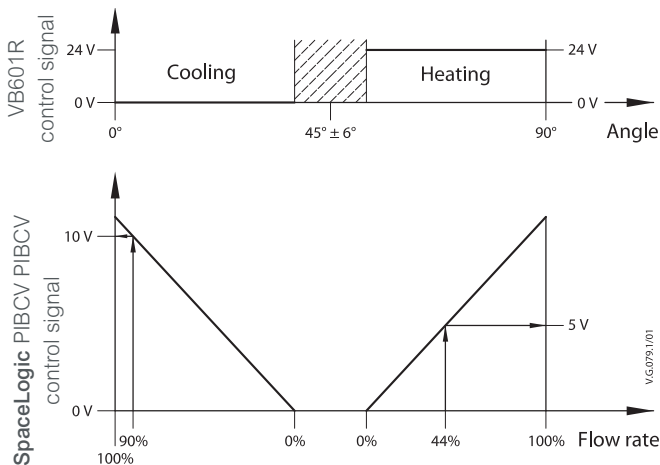

Ordering

6-Way Valve Bodies

DN	kVS (m³/h)	Connection	Part No.
15	2.4	Rp ½	VB601R-15B
20	4.0	Rp ¾	VB601R-20B

Two-Position Rotary Actuator

Supply voltage (V)	Speed (s / 90°)	Cable length (m)	Part No.
24 AC	80	1.5	MB10-24T
		10	MB10-24T-10M

Application Principles

Typical Applications

- Radiant ceiling panel, supplied by 4 pipes (Heating supply and return and cooling supply and return);
- Fan coil unit, with single coil supplied by 4 pipes (Heating supply and return and cooling supply and return).

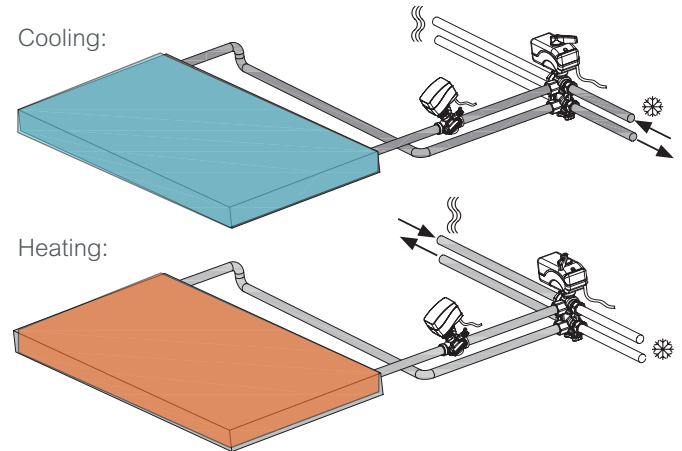

Pump head calculation

To calculate required pump head:

- determine the critical circuit;
- calculate pump head without VB601R solution (VB601R + **SpaceLogic** PIBCV);
- starting pressure for VB601R solution is ~20kPa (VB601R 3.6kPa + **SpaceLogic** PIBCV 16kPa);
- add the starting pressure to the pump head.

Anti-Sticking Requirements

To reduce the risk of the ball valve sticking due to water quality, the valve must be partially rotated at least every 7 days and operation at least once per week to reduce the risk of higher torque loading on the actuator. Reversing the control signal for a maximum of 40 seconds will rotate the valve through 45 degrees to the zero flow position without changing between heating and cooling.

Dimensions (mm)

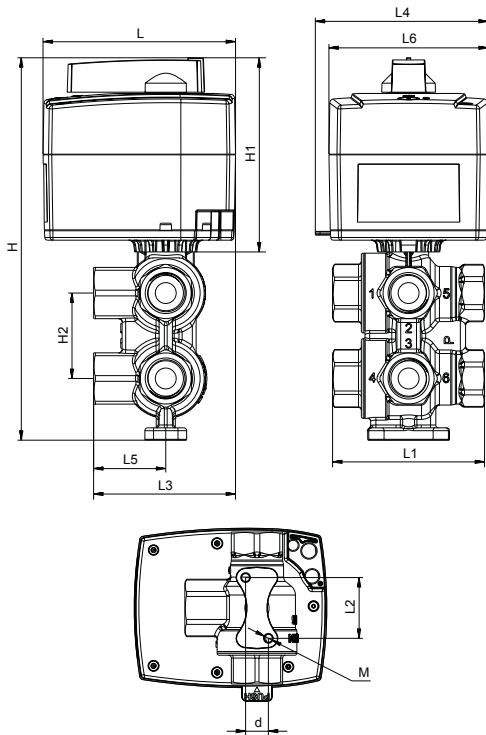

DN	L1	L2	L3	L4	L5	L6	H	H1	H2	d	M
	mm										
15	81		75	92	38	84	202	103	45	12	M5
20	92	32	82	92	45	84	224	103	60		

Design

1. Valve body
2. Connection
3. Ball with L-bore
4. Ball sealing with O-ring
5. Spindle with double O-ring
6. Connection spindle with O-ring
7. Actuator
8. Actuator connection pin
9. Snap ring

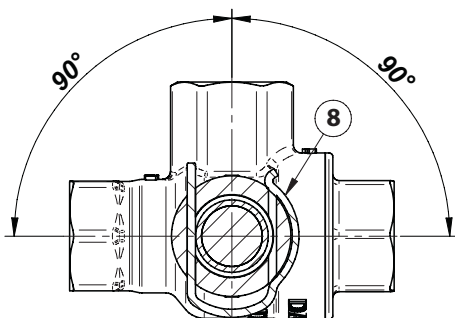
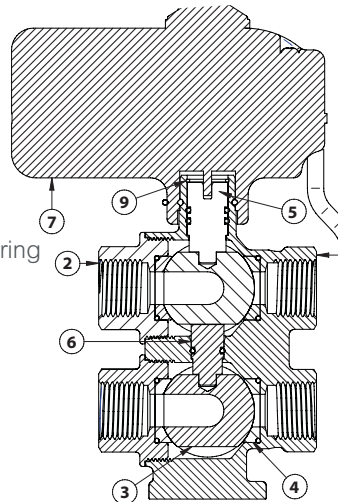

Indication and Setup

Actuator operation is indicated with LED lights.

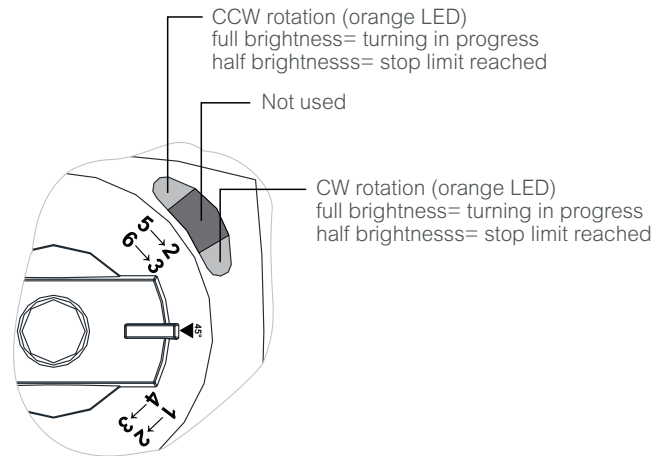

Actuator default setup is to have start position in CW limit position. Once controlled with the 24 V control phase, it will turn to the end position which is CCW limit position.

Default start and end position can be reversed by means of 2 jumpers on the actuator PCB.

To access them unscrew the screw (1), remove the handle (2), unscrew the screws of actuator cover (3) and remove the actuator cover (4).

Adjust the jumpers to correspond the requested start and end position.

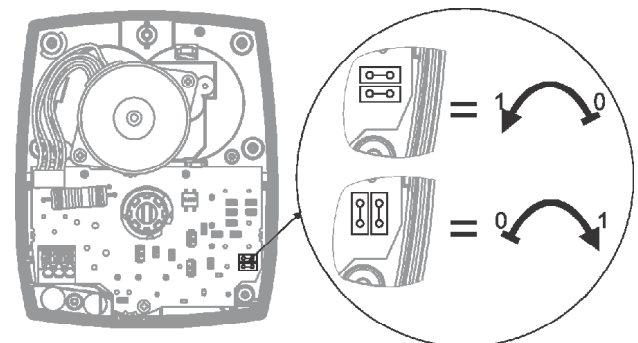

1 After adjusting the jumpers, put back the cover (1) and screw (2) it down, put back the handle (3) and screw it down with screw (4).

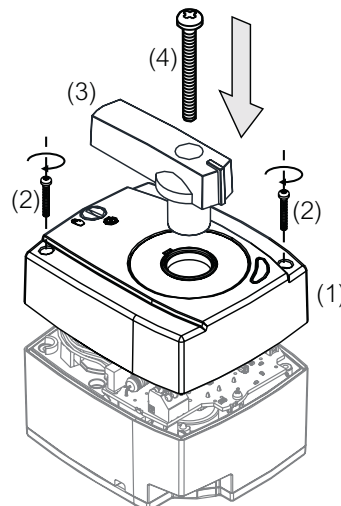

Isolation

Due to the valve design and construction there is no mixing possible between the heating and cooling circuit.

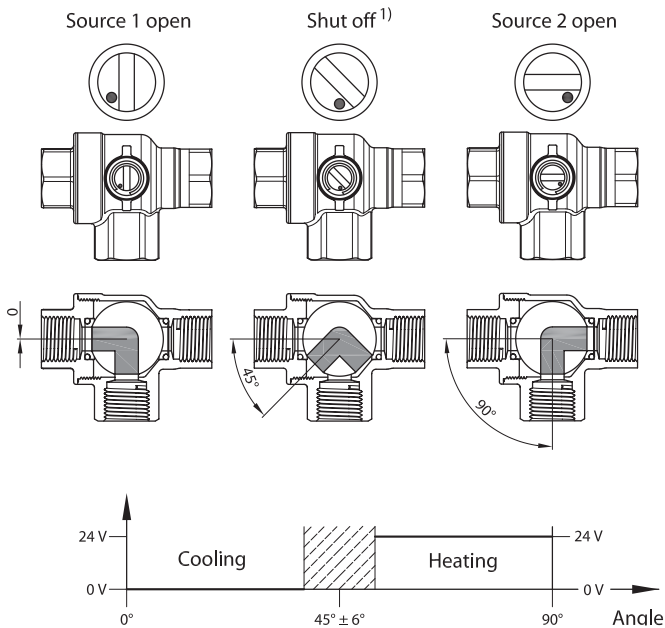



¹⁾ manual override (for service purposes only)

Manual Override

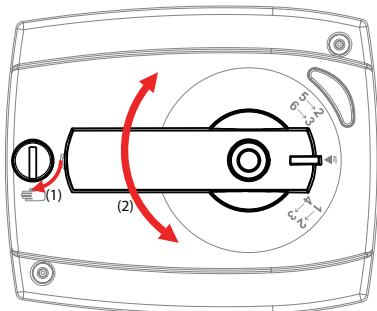
Do not manually operate the drive if power is connected. If manual override has been used when power is connected actuator will always return to its end position. To operate the manual override lever, first depress and hold the motor clutch button.



- Turn the clutch knob (1) to manual mode .
- Turn the knob (2) to rotate the valve to requested position.
- Turn the clutch knob (1) back to automatic position , once the manual mode should be finished.

Wiring and Connections

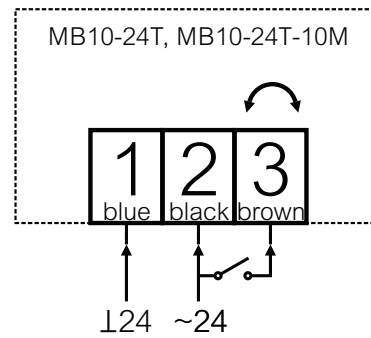

Marking

The 6 ports of the VB601R valve allow the following flow directions.

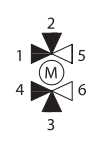
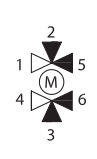
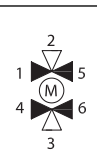
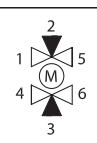
	Control signal - 0 VAC (brown wire): Port 1 to port 2 and port 3 to port 4
	Control signal - 24 VAC (brown wire): Port 5 to port 2 and port 3 to port 6
	Heating or cooling distribution pipes Ports 1, 4, 5 and 6
	Terminal unit pipes Ports 2 and 3

