

Product Environmental Profile

Sedna - One-way switch - 10AX - Brushed Aluminium

Representative of all Sedna switches, with or without the central plates and the range accessories

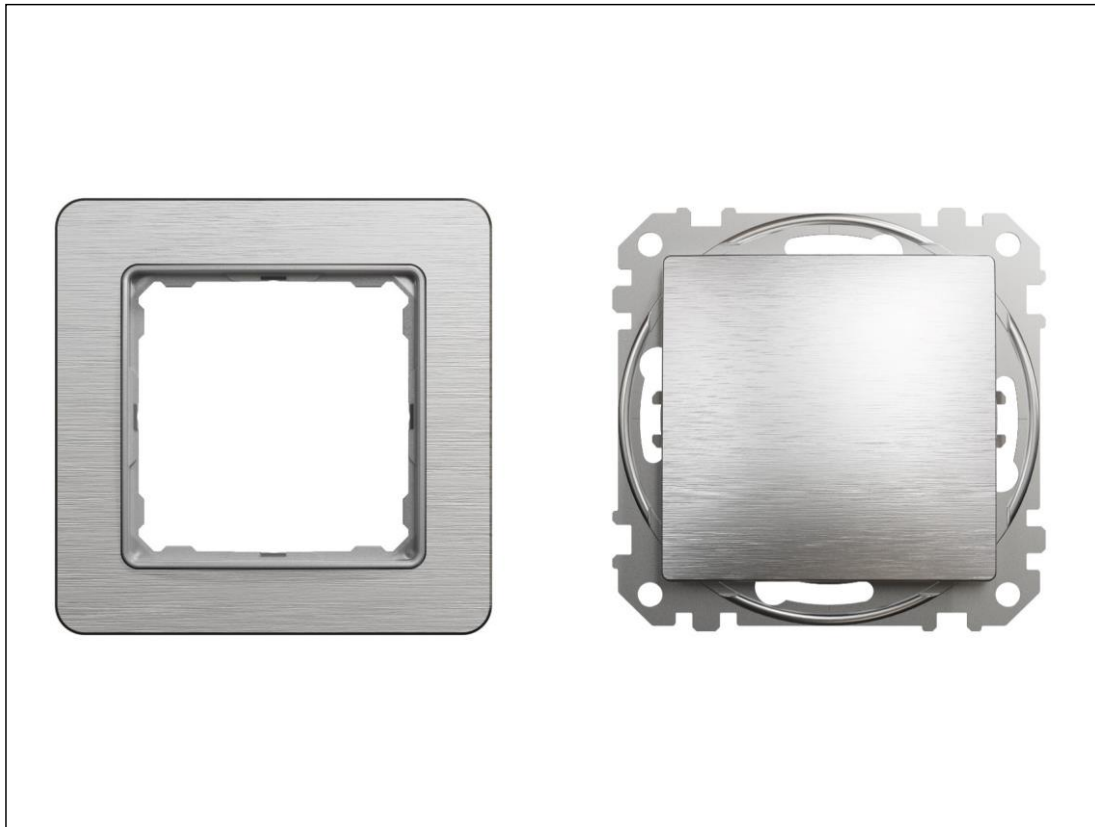



General information

Reference product	Sedna - One-way switch - 10AX - Brushed Aluminium - SDD170101U - SDD370801U
Description of the product	Sedna one-way switch is a product to give the control for a lighting circuit in an electricity network.
Description of the range	The products of the range are: All Sedna switches, with or without the central plates and the range accessories The environmental impacts of this reference product are representative of the impacts of the other products of the range which are developed with a similar technology.
Functional unit	Establish, support and interrupt the rated current I and rated voltage U, and, if applicable, the specific specifications, for a wall-mounted or enclosure / cabinet installation, according to the appropriate use scenario, while protecting them against the penetration of solid objects and liquids (IP20), and with a degree of protection against external mechanical impacts (IK02) in accordance with the standard IEC 62262 according to the appropriate use scenario and for the reference service life of the product of 20 years.
Specifications are:	I = 10A U = 250V AC - Low voltage IP = IP20 Degree of protection against ingress of solid foreign objects and water with harmful effects in accordance with the standard IEC 60529 IK = IK02 Degree of protection against external mechanical impacts in accordance with the standards IEC 62262



Constituent materials

Reference product mass 91 g including the product, its packaging, additional elements and accessories

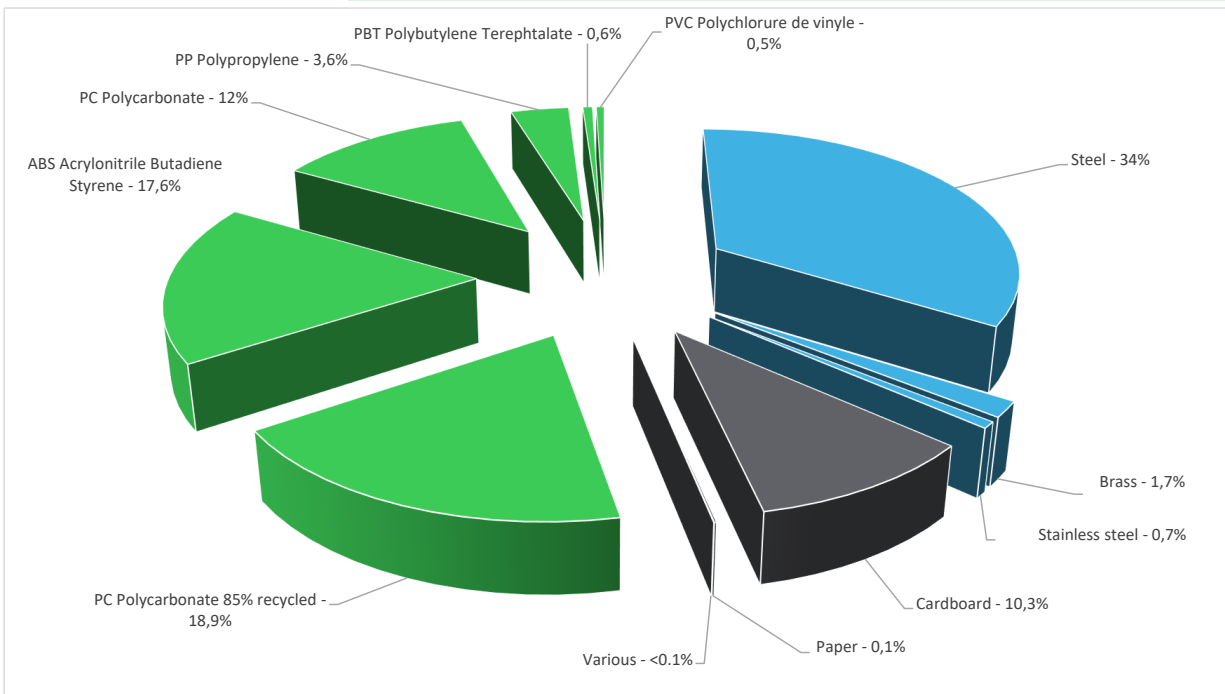

Plastics	53,2%
Metals	36,4%
Others	10,4%



Substance assessment

Details of ROHS and REACH substances information are available on the Schneider-Electric website

<https://www.se.com>



Additional environmental information

End Of Life	Recyclability potential:	42%	The recyclability rate was calculated from the recycling rates of each material making up the product based on REEECYLAB tool developed by Ecosystem, for components/materials not covered by the tool, data from the EIME database and the related PSR was taken. If no data was found a conservative assumption was used (0% recyclability).
-------------	--------------------------	-----	--



Environmental impacts

Reference service life time	20 years		
Product category	Switches - Wall-mounted		
Life cycle of the product	The manufacturing, the distribution, the installation, the use and the end of life were taken into consideration in this study		
Electricity consumption	The electricity consumed during manufacturing processes is considered for each part of the product individually, the final assembly generates a negligible consumption		
Installation elements	No special components needed		
Use scenario	Load rate = 10% I Use rate = 30% RLT		
Time representativeness	The collected data are representative of the year 2024		
Technological representativeness	The Modules of Technologies such as material production, manufacturing processes and transport technology used in the PEP analysis (LCA EIME in the case) are Similar and Representative of the actual type of technologies used to make the product.		
Final assembly site	Elda, Poland		
Geographical representativeness	Europe		
Energy model used	[A1 - A3]	[A5]	[B6]
	Electricity Mix; Low voltage; 2020; Poland, PL	Electricity Mix; Low voltage; 2020; Europe, EU-27	Electricity Mix; Low voltage; 2020; Europe, EU-27
			[C1 - C4]
			Electricity Mix; Low voltage; 2020; Europe, EU-27

Detailed results of the optional indicators mentioned in PCRed4 are available in the LCA report and on demand in a digital format - Country Customer Care Center - <http://www.se.com/contact>

Mandatory Indicators		Sedna - One-way switch - 10AX - Brushed Aluminium - SDD170101U - SDD370801U						
Impact indicators	Unit	Total (without Module D)	[A1 - A3] - Manufacturing	[A4] - Distribution	[A5] - Installation	[B1 - B7] - Use	[C1 - C4] - End of life	[D] - Benefits and loads
Contribution to climate change	kg CO2 eq	7,99E-01	4,92E-01	1,77E-02	1,50E-02	6,48E-02	2,10E-01	-1,27E-01
Contribution to climate change-fossil	kg CO2 eq	8,04E-01	4,98E-01	1,77E-02	1,45E-02	6,47E-02	2,10E-01	-1,27E-01
Contribution to climate change-biogenic	kg CO2 eq	-5,51E-03	-6,11E-03	0*	0*	0*	0*	-2,26E-04
Contribution to climate change-land use and land use change	kg CO2 eq	3,67E-05	3,67E-05	0*	0*	0*	0*	0,00E+00
Contribution to ozone depletion	kg CFC-11 eq	9,03E-09	8,41E-09	2,72E-11	1,42E-10	3,14E-10	1,44E-10	-1,97E-08
Contribution to acidification	mol H+ eq	2,91E-03	2,00E-03	1,12E-04	3,48E-05	3,32E-04	4,21E-04	-7,42E-04
Contribution to eutrophication, freshwater	kg (PO4) ³⁻ eq	3,89E-06	3,36E-06	6,65E-09	2,57E-07	1,71E-07	9,15E-08	-2,71E-07
Contribution to eutrophication marine	kg N eq	6,89E-04	4,75E-04	5,26E-05	1,38E-05	4,05E-05	1,07E-04	-7,36E-05
Contribution to eutrophication, terrestrial	mol N eq	7,50E-03	4,98E-03	5,77E-04	1,02E-04	6,50E-04	1,19E-03	-8,55E-04
Contribution to photochemical ozone formation - human health	kg COVNM eq	2,16E-03	1,50E-03	1,46E-04	2,32E-05	1,27E-04	3,62E-04	-3,01E-04
Contribution to resource use, minerals and metals	kg Sb eq	4,80E-06	4,80E-06	6,97E-10	0*	2,29E-08	0*	-3,89E-05
Contribution to resource use, fossils	MJ	2,60E+01	1,69E+01	2,47E-01	1,18E-01	1,64E+00	7,05E+00	-2,97E+00
Contribution to water use	m3 eq	2,04E-01	1,52E-01	6,73E-05	1,20E-03	4,97E-03	4,53E-02	-5,57E-02

Inventory flows Indicators		Sedna - One-way switch - 10AX - Brushed Aluminium - SDD170101U - SDD370801U						
Inventory flows	Unit	Total (without Module D)	[A1 - A3] - Manufacturing	[A4] - Distribution	[A5] - Installation	[B1 - B7] - Use	[C1 - C4] - End of life	[D] - Benefits and loads
Contribution to use of renewable primary energy excluding renewable primary energy used as raw material	MJ	7,68E-01	3,18E-01	3,30E-04	1,60E-02	4,33E-01	4,59E-04	-2,27E-02
Contribution to use of renewable primary energy resources used as raw material	MJ	2,68E-01	2,68E-01	0*	0*	0*	0*	-1,65E-03
Contribution to total use of renewable primary energy resources	MJ	1,04E+00	5,86E-01	3,30E-04	1,60E-02	4,33E-01	4,59E-04	-2,44E-02
Contribution to use of non renewable primary energy excluding non renewable primary energy used as raw material	MJ	2,42E+01	1,52E+01	2,47E-01	1,18E-01	1,64E+00	7,05E+00	-2,91E+00
Contribution to use of non renewable primary energy resources used as raw material	MJ	1,75E+00	1,75E+00	0*	0*	0*	0*	-5,82E-02
Contribution to total use of non-renewable primary energy resources	MJ	2,60E+01	1,69E+01	2,47E-01	1,18E-01	1,64E+00	7,05E+00	-2,97E+00
Contribution to use of secondary material	kg	1,79E-02	1,79E-02	0*	0*	0*	0*	0,00E+00
Contribution to use of renewable secondary fuels	MJ	0,00E+00	0*	0*	0*	0*	0*	0,00E+00
Contribution to use of non renewable secondary fuels	MJ	0,00E+00	0*	0*	0*	0*	0*	0,00E+00
Contribution to net use of freshwater	m³	4,74E-03	3,54E-03	1,57E-06	2,79E-05	1,17E-04	1,05E-03	-1,30E-03
Contribution to hazardous waste disposed	kg	2,15E-01	2,12E-01	0*	2,63E-04	2,84E-03	0*	-3,06E+00
Contribution to non hazardous waste disposed	kg	3,83E-01	3,14E-01	6,22E-04	6,71E-03	1,09E-02	5,04E-02	-1,00E-01
Contribution to radioactive waste disposed	kg	1,91E-04	1,85E-04	4,43E-07	6,99E-07	2,51E-06	2,21E-06	-4,51E-05
Contribution to components for reuse	kg	0,00E+00	0*	0*	0*	0*	0*	0,00E+00
Contribution to materials for recycling	kg	3,87E-02	4,93E-03	0*	1,35E-03	0*	3,24E-02	0,00E+00
Contribution to materials for energy recovery	kg	0,00E+00	0*	0*	0*	0*	0*	0,00E+00
Contribution to exported energy	MJ	7,78E-04	4,55E-05	0*	4,12E-04	0*	3,21E-04	0,00E+00

* represents less than 0.01% of the total life cycle of the reference flow

Contribution to biogenic carbon content of the product kg of C 0,00E+00

Contribution to biogenic carbon content of the associated packaging kg of C 2,66E-03

* The calculation of the biogenic carbon is based on the Ademe for the Cardboard (28%), EN16485 for Wood (39,52%), and APESA/RECORD for Paper (37,8%)

Mandatory Indicators		Sedna - One-way switch - 10AX - Brushed Aluminium - SDD170101U - SDD370801U								
Impact indicators	Unit	[B1 - B7] - Use	[B1]	[B2]	[B3]	[B4]	[B5]	[B6]	[B7]	
Contribution to climate change	kg CO2 eq	6,48E-02	0*	0*	0*	0*	0*	6,48E-02	0*	
Contribution to climate change-fossil	kg CO2 eq	6,47E-02	0*	0*	0*	0*	0*	6,47E-02	0*	
Contribution to climate change-biogenic	kg CO2 eq	0*	0*	0*	0*	0*	0*	0*	0*	
Contribution to climate change-land use and land use change	kg CO2 eq	0*	0*	0*	0*	0*	0*	0*	0*	
Contribution to ozone depletion	kg CFC-11 eq	3,14E-10	0*	0*	0*	0*	0*	3,14E-10	0*	
Contribution to acidification	mol H+ eq	3,32E-04	0*	0*	0*	0*	0*	3,32E-04	0*	
Contribution to eutrophication, freshwater	kg (PO4) ³⁻ eq	1,71E-07	0*	0*	0*	0*	0*	1,71E-07	0*	
Contribution to eutrophication marine	kg N eq	4,05E-05	0*	0*	0*	0*	0*	4,05E-05	0*	
Contribution to eutrophication, terrestrial	mol N eq	6,50E-04	0*	0*	0*	0*	0*	6,50E-04	0*	
Contribution to photochemical ozone formation - human health	kg COVNM eq	1,27E-04	0*	0*	0*	0*	0*	1,27E-04	0*	
Contribution to resource use, minerals and metals	kg Sb eq	2,29E-08	0*	0*	0*	0*	0*	2,29E-08	0*	
Contribution to resource use, fossils	MJ	1,64E+00	0*	0*	0*	0*	0*	1,64E+00	0*	
Contribution to water use	m3 eq	4,97E-03	0*	0*	0*	0*	0*	4,97E-03	0*	

Inventory flows Indicators		Sedna - One-way switch - 10AX - Brushed Aluminium - SDD170101U - SDD370801U								
Inventory flows	Unit	[B1 - B7] - Use	[B1]	[B2]	[B3]	[B4]	[B5]	[B6]	[B7]	
Contribution to use of renewable primary energy excluding renewable primary energy used as raw material	MJ	4,33E-01	0*	0*	0*	0*	0*	4,33E-01	0*	
Contribution to use of renewable primary energy resources used as raw material	MJ	0*	0*	0*	0*	0*	0*	0*	0*	
Contribution to total use of renewable primary energy resources	MJ	4,33E-01	0*	0*	0*	0*	0*	4,33E-01	0*	
Contribution to use of non renewable primary energy excluding non renewable primary energy used as raw material	MJ	1,64E+00	0*	0*	0*	0*	0*	1,64E+00	0*	
Contribution to use of non renewable primary energy resources used as raw material	MJ	0*	0*	0*	0*	0*	0*	0*	0*	
Contribution to total use of non-renewable primary energy resources	MJ	1,64E+00	0*	0*	0*	0*	0*	1,64E+00	0*	
Contribution to use of secondary material	kg	0*	0*	0*	0*	0*	0*	0*	0*	
Contribution to use of renewable secondary fuels	MJ	0*	0*	0*	0*	0*	0*	0*	0*	
Contribution to use of non renewable secondary fuels	MJ	0*	0*	0*	0*	0*	0*	0*	0*	
Contribution to net use of freshwater	m³	1,17E-04	0*	0*	0*	0*	0*	1,17E-04	0*	
Contribution to hazardous waste disposed	kg	2,84E-03	0*	0*	0*	0*	0*	2,84E-03	0*	
Contribution to non hazardous waste disposed	kg	1,09E-02	0*	0*	0*	0*	0*	1,09E-02	0*	
Contribution to radioactive waste disposed	kg	2,51E-06	0*	0*	0*	0*	0*	2,51E-06	0*	
Contribution to components for reuse	kg	0*	0*	0*	0*	0*	0*	0*	0*	
Contribution to materials for recycling	kg	0*	0*	0*	0*	0*	0*	0*	0*	
Contribution to materials for energy recovery	kg	0*	0*	0*	0*	0*	0*	0*	0*	
Contribution to exported energy	MJ	0*	0*	0*	0*	0*	0*	0*	0*	

* represents less than 0.01% of the total life cycle of the reference flow

Life cycle assessment performed with EIME version v6.2.2, database version 2024-01 in compliance with ISO14044, EF3,1 method is applied, for biogenic carbon storage, assessment methodology -1/1 is used

According to this environmental analysis, proportionality rules may be used to evaluate the impacts of other products of this range, ratios to apply can be provided upon request

Please note that the values given above are only valid within the context specified and cannot be used directly to draw up the environmental assessment of an installation.

Registration number :	SCHN-00208-V02.01-EN	Drafting rules	PCR-4-ed4-EN-2021 09 06
		Supplemented by	PSR-0005-ed3.1-EN-2023 12 08
Verifier accreditation N°	VH48	Information and reference documents	www.pep-ecopassport.org
Date of issue	01-2025	Validity period	5 years
Independent verification of the declaration and data, in compliance with ISO 14025 : 2006			
Internal External X			
The PCR review was conducted by a panel of experts chaired by Julie Orgelet (DDemain)			
PEPs are compliant with XP C08-100-1:2016 and EN 50693:2019 or NF E38-500 :2022			
The components of the present PEP may not be compared with components from any other program.			
Document complies with ISO 14025:2006 "Environmental labels and declarations. Type III environmental declarations"			
			

Schneider Electric Industries SAS

Country Customer Care Center
<http://www.se.com/contact>

35, rue Joseph Monier
 CS 30323
 F- 92500 Rueil Malmaison Cedex
 RCS Nanterre 954 503 439
 Capital social 928 298 512 €

www.se.com

Published by Schneider Electric

SCHN-00208-V02.01-EN

©2024 - Schneider Electric – All rights reserved

01-2025