

# Product End of Life Instructions

**CVS250F ETS 2.2 250A 3P circuit breaker**

**EasyPact 125-250A circuit breaker**



**Schneider**  
Electric



## End of Life Instructions

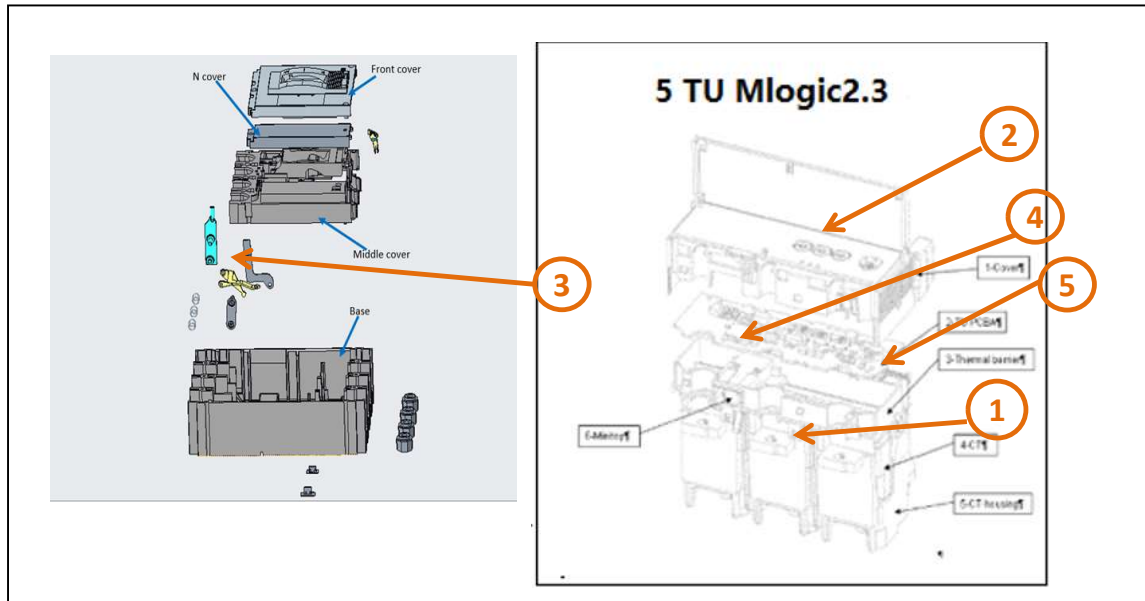

Recommendation	Number on drawing	Component / Material	Weight (in g)	Comment
To be depolluted	1	plastic parts with brominated flame retardants	2.4350027	
To be depolluted	2	plastic parts with brominated flame retardants	0.7659952	
To be depolluted	3	plastic parts with brominated flame retardants	1.6778999	
To be depolluted	4	Electronic Board (Communication) > 10cm <sup>2</sup>	2.685	
To be depolluted	5	Electronic Board (Communication) > 10cm <sup>2</sup>	10.56	

## Product description

Manufacturer identification	Schneider Electric Industries SAS
Brand name	Schneider Electric
Product function	The EasyPact CVS250F ETS 2.2 circuit breakers is designed to guarantee the protection of electrical applications.
Product reference	LV525506
Additional similar product references	EasyPact CVS 160-250A ETS molded-case circuit breaker
Total representative product mass	2000 g
Representative product dimensions	105mm x 161mm x 86mm
Accessories	No
Date of information release	2023/11/10

## Additional information

Legal information	This product family is in the scope of European Union directive 2012/19/EU on Waste Electrical and Electronic Equipment (WEEE). The product family must be disposed according to the legislation of the country. This document is intended for use by end of life recyclers or treatment facilities. It provides the basic information to assure an appropriate end of life treatment for the components and materials of the product.	
In case of special transportation: transportation method	No	
Recyclability potential	54%	Recyclability rate has been calculated based on REEECY'LAB tool developed by Ecosystem, for components/materials not covered by the tool, data from the "ECO' DEEE recyclability and recoverability calculation method" was taken. If no data was found a conservative assumption was used (0% recyclability).

Schneider Electric Industries SAS  
 Country Customer Care Center  
<http://www.schneider-electric.com/contact>  
 35, rue Joseph Monier  
 CS 30323  
 F- 92500 Rueil Malmaison Cedex  
 RCS Nanterre 954 503 439  
 Capital social 896 313 776 €

[www.se.com](http://www.se.com)

ENVEOLI2312016\_V1

Published by Schneider Electric

© 2023 - Schneider Electric – All rights reserved

2023/11/10