

# Modicon M660 Motion Controller

## Hardware Guide

EIO0000005519.01

10/2025

# Legal Information

The information provided in this document contains general descriptions, technical characteristics and/or recommendations related to products/solutions.

This document is not intended as a substitute for a detailed study or operational and site-specific development or schematic plan. It is not to be used for determining suitability or reliability of the products/solutions for specific user applications. It is the duty of any such user to perform or have any professional expert of its choice (integrator, specifier or the like) perform the appropriate and comprehensive risk analysis, evaluation and testing of the products/solutions with respect to the relevant specific application or use thereof.

The Schneider Electric brand and any trademarks of Schneider Electric SE and its subsidiaries referred to in this document are the property of Schneider Electric SE or its subsidiaries. All other brands may be trademarks of their respective owner.

This document and its content are protected under applicable copyright laws and provided for informative use only. No part of this document may be reproduced or transmitted in any form or by any means (electronic, mechanical, photocopying, recording, or otherwise), for any purpose, without the prior written permission of Schneider Electric.

Schneider Electric does not grant any right or license for commercial use of the document or its content, except for a non-exclusive and personal license to consult it on an "as is" basis.

Schneider Electric reserves the right to make changes or updates with respect to or in the content of this document or the format thereof, at any time without notice.

**To the extent permitted by applicable law, no responsibility or liability is assumed by Schneider Electric and its subsidiaries for any errors or omissions in the informational content of this document, as well as any non-intended use or misuse of the content thereof.**

---

# Table of Contents

Safety Information.....	5
Qualification of Personnel .....	5
Intended Use.....	6
Before You Begin.....	6
Start-up and Test .....	7
Operation and Adjustments .....	8
About the Document.....	9
System Overview .....	13
Introduction.....	13
Overview .....	14
Type Code .....	21
Accessories and Spare Parts.....	23
Technical Data.....	24
General Data.....	24
Environmental Data .....	26
Mechanical Data.....	30
Input Power.....	34
Electromagnetic Compatibility .....	35
Power Supply.....	36
Digital Inputs .....	37
Input for Controlling Power On/Power Off/Standby .....	38
Status Output (Watchdog).....	39
Ethernet Ports .....	40
USB Ports.....	42
PCI Express Card Slots.....	43
PCI Express Mini Card Slots.....	44
DisplayPort .....	45
SD Card Slot .....	46
Installation.....	47
Mechanical Installation.....	47
Prerequisites and Requirements .....	47
Mounting .....	51
Electrical Installation .....	55
Electromagnetic Compatibility.....	55
Grounding .....	56
Wiring the Power Supply .....	58
Wiring the Digital Inputs.....	61
Wiring the Status Output (Watchdog).....	63
Wiring the Input for Controlling Power On/Off/Standby .....	66
Installation of Accessories .....	68
Installation of an Optional Fan Kit.....	68
Installation of a Buffer Battery .....	70
Installation of a USB Security Key .....	73
Installation of PCI Express Mini Card Module or Card .....	75
Installation of PCI Express Cards .....	83
Commissioning.....	89
Commissioning .....	89

---

Operation .....	91
Introduction .....	91
Powering On/Powering Off/Setting to Standby .....	92
Motion System Watchdog and Status Output .....	95
Hardware Diagnostics .....	96
Maintenance .....	99
Maintenance .....	99
Index .....	101

# Safety Information

## Important Information

Read these instructions carefully, and look at the equipment to become familiar with the device before trying to install, operate, service, or maintain it. The following special messages may appear throughout this documentation or on the equipment to warn of potential hazards or to call attention to information that clarifies or simplifies a procedure.





The addition of this symbol to a “Danger” or “Warning” safety label indicates that an electrical hazard exists which will result in personal injury if the instructions are not followed.



This is the safety alert symbol. It is used to alert you to potential personal injury hazards. Obey all safety messages that follow this symbol to avoid possible injury or death.

 <b>DANGER</b>
<b>DANGER</b> indicates a hazardous situation which, if not avoided, <b>will result in</b> death or serious injury.

 <b>WARNING</b>
<b>WARNING</b> indicates a hazardous situation which, if not avoided, <b>could result in</b> death or serious injury.

 <b>CAUTION</b>
<b>CAUTION</b> indicates a hazardous situation which, if not avoided, <b>could result in</b> minor or moderate injury.

<b>NOTICE</b>
<b>NOTICE</b> is used to address practices not related to physical injury.

## Please Note

Electrical equipment should be installed, operated, serviced, and maintained only by qualified personnel. No responsibility is assumed by Schneider Electric for any consequences arising out of the use of this material.

A qualified person is one who has skills and knowledge related to the construction and operation of electrical equipment and its installation, and has received safety training to recognize and avoid the hazards involved.

## Qualification of Personnel

Only appropriately trained persons who are familiar with and understand the contents of this manual and all other pertinent product documentation as well as all documentation of all components and equipment of the machine/process are authorized to work on and with this product.

The qualified person must be able to detect possible hazards that may arise from parameterization, modifying configurations, settings, and wiring, and generally from mechanical, electrical, or electronic equipment.

If the product described in the present document is used to implement functions related to functional safety, the qualified person must be a certified expert in functional safety.

The qualified person must be familiar with and understand the contents of the risk assessment as per ISO 12100 and/or any other equivalent assessment as well as all documents related to such risk assessment or equivalent assessments for the machine/process.

The qualified person must be familiar with the standards, provisions, and regulations for the prevention of industrial accidents, which they must observe when designing, implementing, and maintaining the machine/process.

The qualified person must be thoroughly familiar with the safety-related applications and the non-safety-related applications used to operate the machine/process.

## Intended Use

The products described or affected by the present document are, together with software, accessories and options, motion controllers (referred to herein as “controller”). Depending on the product version, the motion controllers described in the present document are equipped with an integrated industrial PC (referred to herein as “industrial PC”). The products are intended for industrial use in industrial environments in accordance with the instructions, directions, examples and safety information contained in the present document and other supporting documentation.

The product may only be used in compliance with all applicable safety regulations and directives, the specified requirements and the technical data.

Prior to using the product, you must perform a risk assessment as per ISO 12100 and/or other equivalent assessment in view of the planned application. Based on the results, the appropriate safety-related measures must be implemented.

Since the product is used as a component in an overall machine or process, you must ensure the safety of persons by means of the design of your overall machine or process.

Operate the product only with the specified cables and accessories. Use only genuine accessories and spare parts.

Any use other than the use explicitly permitted is prohibited and can result in unanticipated hazards.

### **▲ WARNING**

#### **UNINTENDED EQUIPMENT OPERATION**

Do not install, use, maintain or service the controller products in any manner or in any environment other than that which is specified herein.

**Failure to follow these instructions can result in death, serious injury, or equipment damage.**

## Before You Begin

Do not use this product on machinery lacking effective point-of-operation guarding. Lack of effective point-of-operation guarding on a machine can result in serious injury to the operator of that machine.

<b>▲ WARNING</b>
<p><b>UNGUARDED EQUIPMENT</b></p> <ul style="list-style-type: none"> <li>• Do not use this software and related automation equipment on equipment which does not have point-of-operation protection.</li> <li>• Do not reach into machinery during operation.</li> </ul> <p><b>Failure to follow these instructions can result in death, serious injury, or equipment damage.</b></p>

This automation equipment and related software is used to control a variety of industrial processes. The type or model of automation equipment suitable for each application will vary depending on factors such as the control function required, degree of protection required, production methods, unusual conditions, government regulations, etc. In some applications, more than one processor may be required, as when backup redundancy is needed.

Only you, the user, machine builder or system integrator can be aware of all the conditions and factors present during setup, operation, and maintenance of the machine and, therefore, can determine the automation equipment and the related safeties and interlocks which can be properly used. When selecting automation and control equipment and related software for a particular application, you should refer to the applicable local and national standards and regulations. The National Safety Council's Accident Prevention Manual (nationally recognized in the United States of America) also provides much useful information.

In some applications, such as packaging machinery, additional operator protection such as point-of-operation guarding must be provided. This is necessary if the operator's hands and other parts of the body are free to enter the pinch points or other hazardous areas and serious injury can occur. Software products alone cannot protect an operator from injury. For this reason the software cannot be substituted for or take the place of point-of-operation protection.

Ensure that appropriate safeties and mechanical/electrical interlocks related to point-of-operation protection have been installed and are operational before placing the equipment into service. All interlocks and safeties related to point-of-operation protection must be coordinated with the related automation equipment and software programming.

**NOTE:** Coordination of safeties and mechanical/electrical interlocks for point-of-operation protection is outside the scope of the Function Block Library, System User Guide, or other implementation referenced in this documentation.

## Start-up and Test

Before using electrical control and automation equipment for regular operation after installation, the system should be given a start-up test by qualified personnel to verify correct operation of the equipment. It is important that arrangements for such a check are made and that enough time is allowed to perform complete and satisfactory testing.

<b>▲ WARNING</b>
<p><b>EQUIPMENT OPERATION HAZARD</b></p> <ul style="list-style-type: none"> <li>• Verify that all installation and set up procedures have been completed.</li> <li>• Before operational tests are performed, remove all blocks or other temporary holding means used for shipment from all component devices.</li> <li>• Remove tools, meters, and debris from equipment.</li> </ul> <p><b>Failure to follow these instructions can result in death, serious injury, or equipment damage.</b></p>

Follow all start-up tests recommended in the equipment documentation. Store all equipment documentation for future references.

**Software testing must be done in both simulated and real environments.**

Verify that the completed system is free from all short circuits and temporary grounds that are not installed according to local regulations (according to the National Electrical Code in the U.S.A, for instance). If high-potential voltage testing is necessary, follow recommendations in equipment documentation to prevent accidental equipment damage.

Before energizing equipment:

- Remove tools, meters, and debris from equipment.
- Close the equipment enclosure door.
- Remove all temporary grounds from incoming power lines.
- Perform all start-up tests recommended by the manufacturer.

## Operation and Adjustments

The following precautions are from the NEMA Standards Publication ICS 7.1-1995:

(In case of divergence or contradiction between any translation and the English original, the original text in the English language will prevail.)

- Regardless of the care exercised in the design and manufacture of equipment or in the selection and ratings of components, there are hazards that can be encountered if such equipment is improperly operated.
- It is sometimes possible to misadjust the equipment and thus produce unsatisfactory or unsafe operation. Always use the manufacturer's instructions as a guide for functional adjustments. Personnel who have access to these adjustments should be familiar with the equipment manufacturer's instructions and the machinery used with the electrical equipment.
- Only those operational adjustments required by the operator should be accessible to the operator. Access to other controls should be restricted to prevent unauthorized changes in operating characteristics.

# About the Document

## Document Scope

This manual describes technical characteristics, installation and maintenance of the motion controller M660.

## Validity Note

This user guide is valid for the standard products listed in the Type Code, page 21.

The characteristics of the products described in this document are intended to match the characteristics that are available on [www.se.com](http://www.se.com). As part of our corporate strategy for constant improvement, we may revise the content over time to enhance clarity and accuracy. If you see a difference between the characteristics in this document and the characteristics on [www.se.com](http://www.se.com), consider [www.se.com](http://www.se.com) to contain the latest information.

## Available Languages of the Document

The document is available in these languages:

- English (EIO0000005519)

## Related Documents

Title of documentation	Reference number
Modicon M660 Motion Controller Programming Guide	EIO0000005527 (ENG)
Cybersecurity Guidelines for EcoStruxure Machine Expert, Modicon and PacDrive Controllers and Associated Equipment User Guide	EIO0000004242 (ENG)
Cybersecurity Best Practices	CS-Best-Practices-2019-340

To find documents online, visit the Schneider Electric download center ([www.se.com/ww/en/download/](http://www.se.com/ww/en/download/)).

## Product Related Information

### DANGER

#### HAZARD OF ELECTRIC SHOCK, EXPLOSION OR ARC FLASH

- Disconnect all power from all equipment including connected devices prior to removing any covers or doors, or installing or removing any accessories, hardware, cables, or wires except under the specific conditions specified in the appropriate hardware guide for this equipment.
- Always use a properly rated voltage sensing device to confirm the power is off where and when indicated.
- Replace and secure all covers, accessories, hardware, cables, and wires and confirm that a proper ground connection exists before applying power to the equipment.
- Use only the specified voltage when operating this equipment and any associated products.

**Failure to follow these instructions will result in death or serious injury.**

This equipment has been designed to operate outside of any hazardous location. Only install this equipment in zones known to be free of a hazardous atmosphere.

### DANGER

#### POTENTIAL FOR EXPLOSION

Install and use this equipment in non-hazardous locations only.

**Failure to follow these instructions will result in death or serious injury.**

### WARNING

#### LOSS OF CONTROL

- Perform a Failure Mode and Effects Analysis (FMEA), or equivalent risk analysis, of your application, and apply preventive and detective controls before implementation.
- Provide a fallback state for undesired control events or sequences.
- Provide separate or redundant control paths wherever required.
- Supply appropriate parameters, particularly for limits.
- Review the implications of transmission delays and take actions to mitigate them.
- Review the implications of communication link interruptions and take actions to mitigate them.
- Provide independent paths for control functions (for example, emergency stop, over-limit conditions, and error conditions) according to your risk assessment, and applicable codes and regulations.
- Apply local accident prevention and safety regulations and guidelines.<sup>1</sup>
- Test each implementation of a system for proper operation before placing it into service.

**Failure to follow these instructions can result in death, serious injury, or equipment damage.**

<sup>1</sup> For additional information, refer to NEMA ICS 1.1 (latest edition), *Safety Guidelines for the Application, Installation, and Maintenance of Solid State Control* and to NEMA ICS 7.1 (latest edition), *Safety Standards for Construction and Guide for Selection, Installation and Operation of Adjustable-Speed Drive Systems* or their equivalent governing your particular location.

<b>▲ WARNING</b>
<p><b>UNINTENDED EQUIPMENT OPERATION</b></p> <ul style="list-style-type: none"> <li>• Only use software approved by Schneider Electric for use with the motion control part of this equipment.</li> <li>• Update your application program every time you change the physical hardware configuration.</li> </ul> <p><b>Failure to follow these instructions can result in death, serious injury, or equipment damage.</b></p>

The controller is intended for operation in an industrial environment as specified by IEC 61000-6-2 and IEC 61000-6-4, and in zone B as specified by IEC 61131-2. Operating the controller in non-industrial environments such as residential, commercial and light-industrial environments as specified in IEC 61000-6-3 can result in radio interference.

<b>▲ WARNING</b>
<p><b>RADIO INTERFERENCE</b></p> <ul style="list-style-type: none"> <li>• Only install and operate the controller in an industrial environment as specified by IEC 61000-6-2 and IEC 61000-6-4, and in zone B as specified by IEC 61131-2.</li> <li>• Do not install and operate the controller in public low-voltage mains power networks.</li> </ul> <p><b>Failure to follow these instructions can result in death, serious injury, or equipment damage.</b></p>

## Information on Non-Inclusive or Insensitive Terminology

As a responsible, inclusive company, Schneider Electric is constantly updating its communications and products that contain non-inclusive or insensitive terminology. However, despite these efforts, our content may still contain terms that are deemed inappropriate by some customers.

## Terminology Derived from Standards

The technical terms, terminology, symbols and the corresponding descriptions in the information contained herein, or that appear in or on the products themselves, are generally derived from the terms or definitions of international standards.

In the area of functional safety systems, drives and general automation, this may include, but is not limited to, terms such as *safety*, *safety function*, *safe state*, *fault*, *fault reset*, *malfunction*, *failure*, *error*, *error message*, *dangerous*, etc.

Among others, these standards include:

Standard	Description
IEC 61131-2:2007	Programmable controllers, part 2: Equipment requirements and tests.
ISO 13849-1:2023	Safety of machinery: Safety related parts of control systems. General principles for design.
EN 61496-1:2020	Safety of machinery: Electro-sensitive protective equipment. Part 1: General requirements and tests.
ISO 12100:2010	Safety of machinery - General principles for design - Risk assessment and risk reduction

Standard	Description
EN 60204-1:2006	Safety of machinery - Electrical equipment of machines - Part 1: General requirements
ISO 14119:2013	Safety of machinery - Interlocking devices associated with guards - Principles for design and selection
ISO 13850:2015	Safety of machinery - Emergency stop - Principles for design
IEC 62061:2021	Safety of machinery - Functional safety of safety-related electrical, electronic, and electronic programmable control systems
IEC 61508-1:2010	Functional safety of electrical/electronic/programmable electronic safety-related systems: General requirements.
IEC 61508-2:2010	Functional safety of electrical/electronic/programmable electronic safety-related systems: Requirements for electrical/electronic/programmable electronic safety-related systems.
IEC 61508-3:2010	Functional safety of electrical/electronic/programmable electronic safety-related systems: Software requirements.
IEC 61784-3:2021	Industrial communication networks - Profiles - Part 3: Functional safety fieldbuses - General rules and profile definitions.
2006/42/EC	Machinery Directive
2014/30/EU	Electromagnetic Compatibility Directive
2014/35/EU	Low Voltage Directive

In addition, terms used in the present document may tangentially be used as they are derived from other standards such as:

Standard	Description
IEC 60034 series	Rotating electrical machines
IEC 61800 series	Adjustable speed electrical power drive systems
IEC 61158 series	Digital data communications for measurement and control – Fieldbus for use in industrial control systems

Finally, the term *zone of operation* may be used in conjunction with the description of specific hazards, and is defined as it is for a *hazard zone* or *danger zone* in the *Machinery Directive (2006/42/EC)* and *ISO 12100:2010*.

**NOTE:** The aforementioned standards may or may not apply to the specific products cited in the present documentation. For more information concerning the individual standards applicable to the products described herein, see the characteristics tables for those product references.

# System Overview

## Introduction

### Overview

The M660 controller family consists of two types.

MN660C devices are purpose-built motion controllers. Features include:

- Up to 65 axes with Sercos
- I/O cycle time via Sercos as low as 1 ms
- Intel Raptor Lake-P processors

MN660P controllers also include the capabilities of an industrial PC. The industrial PC opens up opportunities to implement, for example:

- Data acquisition and processing at the edge instead of at a remote, centralized host
- OS virtualization (Windows)
- Extensive logging, analytics and diagnostics
- Visualization, dashboards

# Overview

## Front View

Front view MN660.....1...:

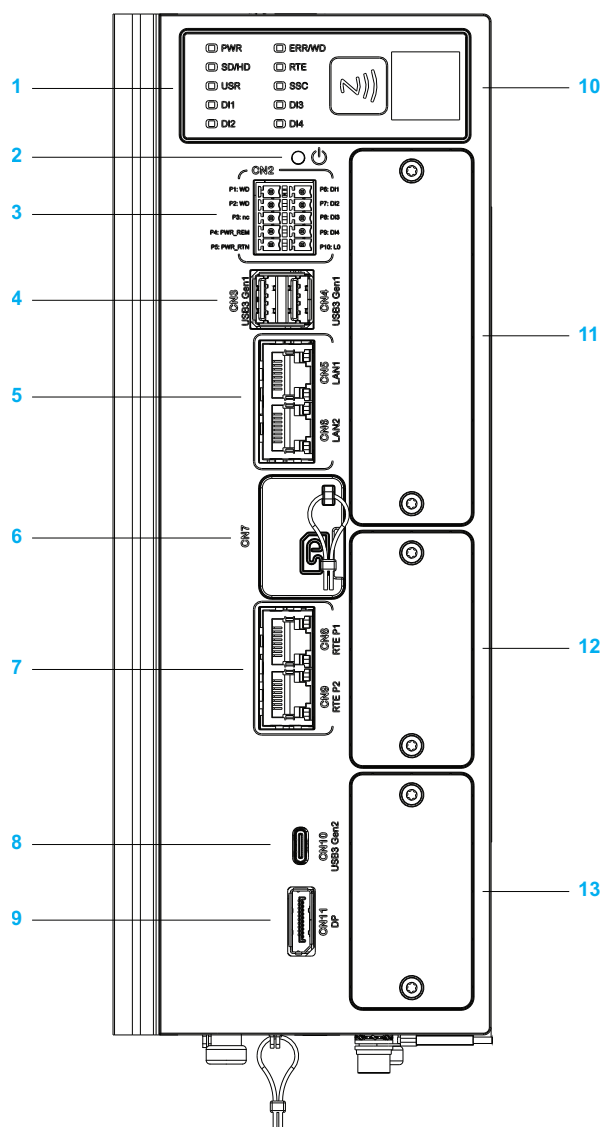

Item number	Item
1	Status LEDs
2	Power button
3	Digital I/Os (CN2): <ul style="list-style-type: none"> <li>4 digital inputs (<b>DI1</b> to <b>DI4</b> and <b>L0</b>)</li> <li>Status output, watchdog (<b>P1: WD</b>, <b>P2: WD</b>)</li> <li>Input for controlling power (<b>P4: PWR_REM</b>, <b>P5: PWR_RTN</b>)</li> </ul>
4	USB3 ports, Gen 1, Type-A (CN3, CN4)
5	Ethernet ports LAN (CN5, CN6)
6	SD card slot (CN7), sealable (sealing wire and seal not included)
7	Real-Time Ethernet ports RTE (CN8, CN9)
8	USB3 port, Gen 2, Type-C (CN10)
9	DisplayPort (CN11)
10	Reserved

Item number	Item
11	Slot for extensions, depending on the product reference
12	Slot 2 for modules
13	Slot 1 for modules

The illustration depicts a controller without equipment installed either the slot for extensions or in slot 1 and slot 2. Your controller may have less or additional extensions, depending on the controller reference. Refer to [Type Code](#), page 21 for details on M660 controller references.

Front view MN660.....2.....:

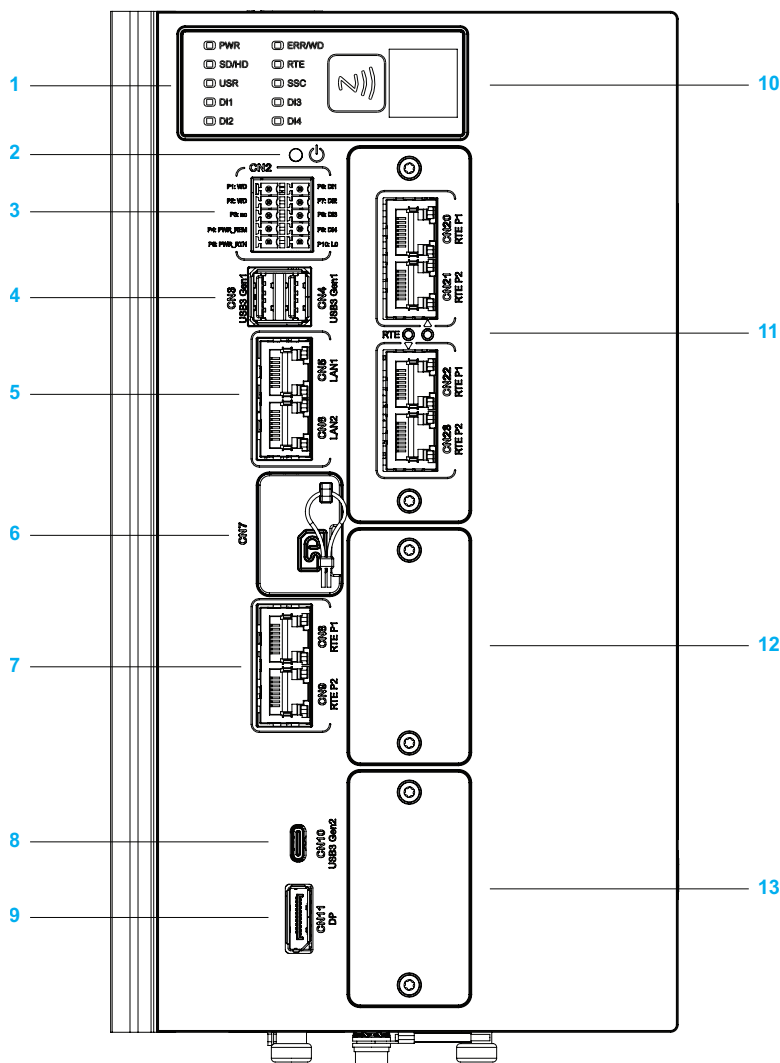

Item number	Item
1	Status LEDs
2	Power button
3	Digital I/Os (CN2): <ul style="list-style-type: none"> <li>• 4 digital inputs (<b>DI1</b> to <b>DI4</b> and <b>L0</b>)</li> <li>• Status output, watchdog (<b>P1: WD</b>, <b>P2: WD</b>)</li> <li>• Input for controlling power (<b>P4: PWR_REM</b>, <b>P5: PWR_RTN</b>)</li> </ul>
4	USB3 ports, Gen 1, Type-A (CN3, CN4)
5	Ethernet ports LAN (CN5, CN6)
6	SD card slot (CN7), sealable (sealing wire and seal not included)
7	Real-Time Ethernet ports RTE (CN8, CN9)
8	USB3 port, Gen 2, Type-C (CN10)
9	DisplayPort (CN11)
10	Reserved
11	Slot for extensions, depending on the product reference
12	Slot 2 for modules
13	Slot 1 for modules

The illustration depicts a controller with a Real-Time Ethernet extension ports RTE (CN20, CN21, CN22, CN23) installed, and without modules in slot 1 and slot 2.

Your controller may have less or additional extensions, depending on the controller reference. Refer to Type Code, page 21 for details on M660 controller references.

## Top View

Top view MN660.....1...:

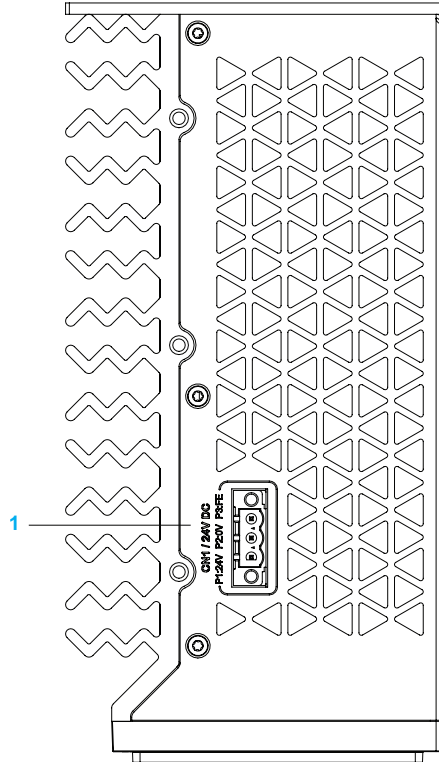

Item number	Item
1	Power supply connector (CN1 / 24V DC)

Top view MN660.....2.....:

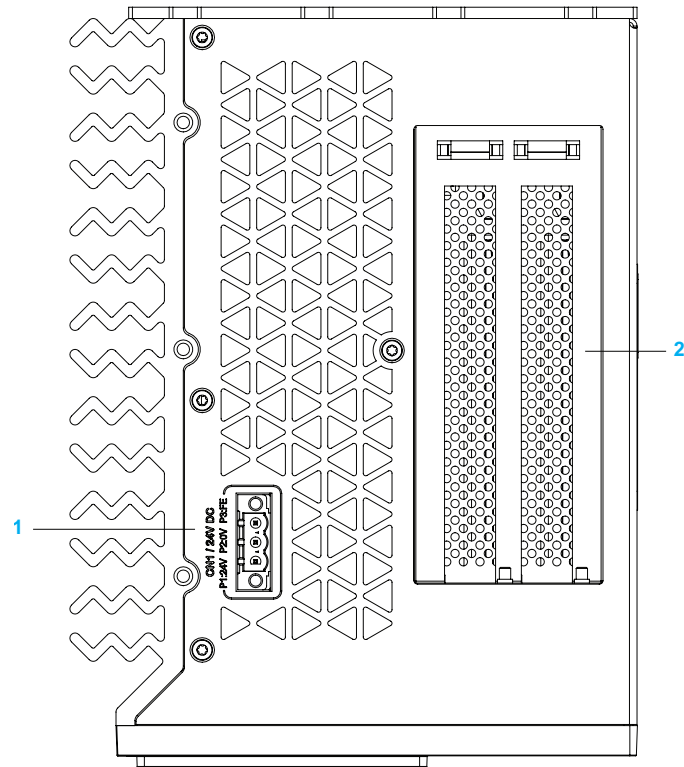

Item number	Item
1	Power supply connector (CN1 / 24V DC)
2	Slots for PCI Express cards

## Bottom View

Bottom view MN660•••••1•••:

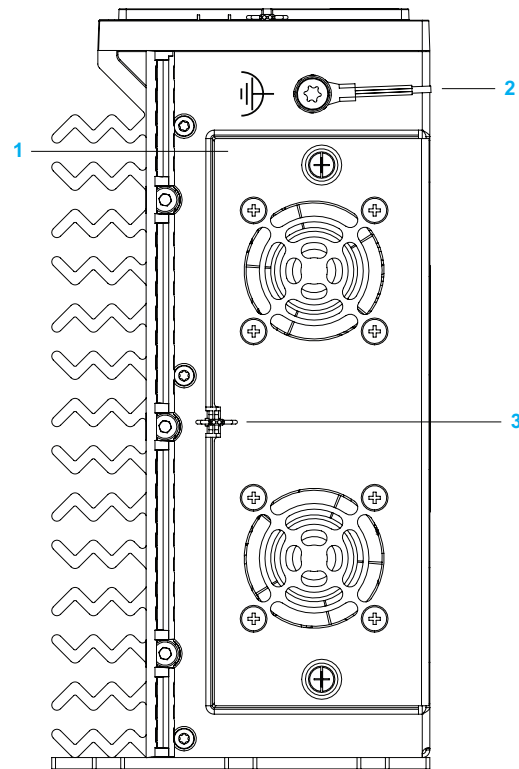

Item number	Item
1	Fan kit
2	Grounding screw for functional ground (FE)
3	Sealing lug, sealable (sealing wire and seal not included)

The illustration shows an MN660•••••1••• controller with an optional fan kit. Your controller may not be equipped with a fan kit. Refer to *Accessories*, page 23 for the fan kit.

Bottom view MN660•••••2•••••:

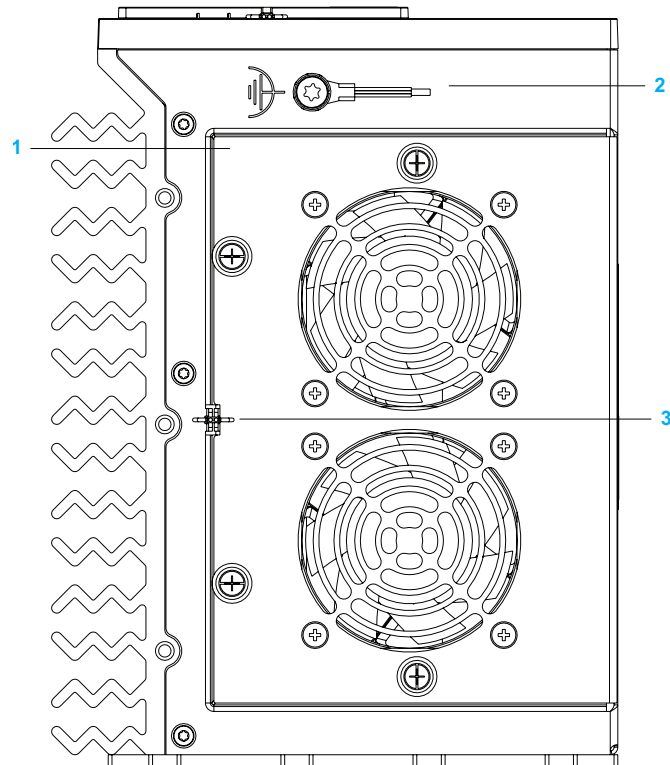

Item number	Item
1	Fan kit
2	Grounding screw for functional ground (FE)
3	Sealing lug, sealable (sealing wire and seal not included)

# Type Code

Item	1	2	3	4	5	6	7	8	9	10	11	12	13	14	15	16	17	18
Type code (example)	M	N	6	6	0	P	3	5	4	N	2	0	1	3	W	0	-	-

Item	Meaning
1 ... 5	<b>Product family</b> MN660 = Controller
6	<b>Controller type</b> C = Purpose-built motion controller P = Motion controller with industrial PC for Edge computing
7	<b>Processor</b> 1 = Intel U300E Raptor Lake 2 = Intel Core™ i3-1320PRE Raptor Lake 3 = Intel Core™ i5-1350PRE Raptor Lake 4 = Intel Core™ i7-1370PRE Raptor Lake
8	<b>Function</b> 5 = Motion control
9	<b>Ethernet</b> 3 = 2 LAN ports, 2 RTE ports 4 = 2 LAN ports, 4 RTE ports 5 = 2 LAN ports, 6 RTE ports
10	<b>Reserved</b> N = Nothing
11	<b>RAM</b> 1 = 4 GB 2 = 8 GB
12	<b>I/O extensions</b> 0 = No I/O extension
13	<b>Housing size and number of PCI Express Card slots</b> 1 = Narrow housing, no PCI Express Card slots 2 = Wide housing, 2 PCI Express Card slots
14	<b>Solid State Drive (SSD)</b> 0 = No SSD 1 = 1 SSD with 256 GB 2 = 1 SSD with 512 GB 3 = 2 SSD with 512 GB each
15	<b>General purpose operating system (GPOS) for industrial PC</b> N = None (MN660C) W = Windows 11 (MN660P)
16	<b>Reserved</b> -

---

Item	Meaning
17	<b>Reserved</b> -
18	<b>Reserved</b> -

If you have questions concerning the type code, contact your local Schneider Electric service representative.

## Accessories and Spare Parts

### Mounting and Installation Accessories and Spare Parts

Description	Commercial Reference
Fan kit for narrow housing	MNAH6AFS01
Fan kit for wide housing, spare part	MNAH6AFL01
Kit for rear wall mounting, narrow housing, spare part	MNAH6MBS
Kit for rear wall mounting, wide housing, spare part	MNAH6MBL
Kit for side wall mounting, narrow and wide housing	MNAH6MF
Cable holder for securing cables in the control cabinet (only for MN660.....1... (narrow housing) controllers)	MNAH6ACH
Spring connectors CN1 and CN2, screws for ground connection, spare part	MNAH6ACS01

### Cables and Cable Adapters

Description	Commercial Reference
Sercos cable, 2 x RJ45 connector, 0.5 m (1.64 ft), red	VW3E5001R005
Sercos cable, 2 x RJ45 connector, 1.0 m (3.29 ft), red	VW3E5001R010
Sercos cable, 2 x RJ45 connector, 1.5 m (4.92 ft), red	VW3E5001R015
Sercos cable, 2 x RJ45 connector, 2.0 m (6.56 ft), red	VW3E5001R020
Sercos cable, 2 x RJ45 connector, 3.0 m (9.84 ft), red	VW3E5001R030
Sercos cable, 2 x RJ45 connector, 5.0 m (16.40 ft), red	VW3E5001R050
Sercos cable, 2 x RJ45 connector, 10.0 m (32.80 ft), red	VW3E5001R100
Sercos cable, 2 x RJ45 connector, 15.0 m (49.21 ft), red	VW3E5001R150
Sercos cable, 2 x RJ45 connector, 20.0 m (65.62 ft), red	VW3E5001R200
Sercos cable, 2 x RJ45 connector, 25.0 m (82.02 ft), red	VW3E5001R250
Sercos cable, 2 x RJ45 connector, 30.0 m (98.43 ft), red	VW3E5001R300
Sercos cable, 2 x RJ45 connector, 40.0 m (131.23 ft), red	VW3E5001R400
Sercos cable, 2 x RJ45 connector, 50.0 m (164.04 ft), red	VW3E3001R500
DP-DVI adapter for connection of Harmony P6 and Harmony FP6 displays	HMIYADDPDVI11

### Miscellaneous Accessories

Description	Commercial Reference
Buffer battery, 3 V, lithium, coin cell, CR2450N	VW3E6020

# Technical Data

## General Data

### Processors and RAM

M660 controllers are equipped with Intel Raptor Lake processors with a hybrid architecture using performance cores (P-Cores) and efficient cores (E-Cores):

Processor	Cores (P-Cores/E-Cores)	Threads	Cache MB	Base frequency (turbo P-Core/turbo E-Core) GHz	RAM GB
Intel U300E Raptor Lake	5 (1/4)	6	8	1.1 (4.3/3.2)	4 (LPDDR5)
Intel Core™ i3-1320PRE Raptor Lake	8 (4/4)	12	12	1.7 (4.5/3.2)	4 or 8 (LPDDR5)
Intel Core™ i5-1350PRE Raptor Lake	12 (4/8)	16	18	1.8 (4.6/3.4)	8 (LPDDR5)
Intel Core™ i7-1370PRE Raptor Lake	14 (6/8)	20	24	1.9 (4.8/3.7)	8 (LPDDR5)

Item 7 of the type code indicates the type of processor of the controller. Item 11 of the type code indicates the amount of RAM. Refer to Type Code, page 21 for details on M660 controller references.

### Solid State Drive (SSD)

MN660P controllers are equipped with Solid State Drives (SSD). The following SSD configurations are available:

- 256 GB (one 256 GB drive)
- 512 GB (one 512 GB drive)
- 1024 GB (two 512 GB drives)

Item 14 of the type code indicates the equipment of the controller with SSDs. Refer to Type Code, page 21 for details on M660 controller references.

### Extensibility

#### PCI Express Mini Card Slots

M660 controllers are equipped with two PCI Express Mini Card slots.

#### PCI Express Card Slots

MN660.....2..... controllers are equipped with two PCI Express Card slots.

Refer to Type Code, page 21 for details on M660 controller types and versions.

### Operating Systems

MN660C controllers:

- VxWorks for motion control part

MN660P controllers:

- VxWorks for motion control part
- Windows for industrial PC part

## Fieldbuses, Automation Communication Protocols

- Sercos

### Motion Control Performance and Network Characteristics

Characteristic	MN660•1	MN660•2	MN660•3	MN660•4
Maximum number of synchronized axes via Sercos	16	64 <sup>(1)</sup>	64 <sup>(1)</sup>	64 <sup>(1)</sup>
Minimum cycle time for axes via Sercos	1 ms			
Minimum cycle time for I/Os via Sercos	1 ms			
(1) The cycle time of 1ms is achieved by switching the axes from idle to cam tasks by no more than 12 axes per cycle until all 64 axes are running in cam mode. Once all axes are in cam mode, you can then switch the cam profiles by 4 axes every 15 ms.				

Item 7 of the type code indicates the type of processor of the controller. Item 11 of the type code indicates the amount of RAM. Refer to [Type Code](#), page 21 for details on M660 controller references.

## Environmental Data

### Environmental Conditions for Long-Term Storage (in Transportation Packaging)

The controller complies with class 1K21 as per IEC 60721-3-1 (climatic conditions):

Characteristic	Unit	Value
Ambient temperature (no icing, no condensation)	°C (°F)	-40 ... 70 (-40 ... 158)
Rate of change of temperature	°C/min (°F/min)	0.5 (0.9)
Relative humidity (non-condensing)	%	5 ... 95

The controller complies with class 2M4 as per IEC 60721-3-2 (mechanical conditions):

Characteristic	Unit	Value
Stationary vibration random, acceleration power spectral density, 2 ... 3 Hz	m <sup>2</sup> /s <sup>3</sup>	10
Stationary vibration random, acceleration power spectral density, 10 ... 20 Hz	m <sup>2</sup> /s <sup>3</sup>	1
Stationary vibration random, acceleration power spectral density, 50 ... 2000 Hz	m <sup>2</sup> /s <sup>3</sup>	0.5
Stationary vibration random, test time	min	30 Each axis (± x / ± y / ± z)
Shock response spectrum, Shock 1 - Curve 4, peak acceleration, 11 ms	m/s <sup>2</sup>	100
Shock response spectrum, Shock 2 – Curve 2, peak acceleration, 6 ms	m/s <sup>2</sup>	300
Number of shocks	-	100 Each axis (± x / ± y / ± z) and direction
Free fall, weight < 20 kg	m (ft)	0.25 (0.82)
Number of free falls	-	2
Toppling, weight < 20 kg	-	Over all edges
Steady-state acceleration	m/s <sup>2</sup>	20
Static load	kPa	5

The controller complies with IEC 61131-2 (mechanical conditions):

Characteristic	Unit	Value
Free fall, weight < 10 kg	m (ft)	1 (3.28)
Number of free falls	-	Once on each face Once on each edge Once on each corner

## Environmental Conditions for Transportation

The controller complies with class 2K12 as per IEC 60721-3-2 (climatic conditions):

Characteristic	Unit	Value
Ambient temperature (no icing, no condensation)	°C (°F)	-40 ... 70 (-40 ... 158)
Change of temperature, air/air	°C (°F)	-25 ... 30 (-13 ... 86)
Relative humidity (non-condensing)	%	5 ... 95

The controller complies with class 2M4 as per IEC 60721-3-2 (mechanical conditions):

Characteristic	Unit	Value
Stationary vibration random, acceleration power spectral density, 2 ... 3 Hz	m <sup>2</sup> /s <sup>3</sup>	10
Stationary vibration random, acceleration power spectral density, 10 ... 20 Hz	m <sup>2</sup> /s <sup>3</sup>	1
Stationary vibration random, acceleration power spectral density, 50 ... 2000 Hz	m <sup>2</sup> /s <sup>3</sup>	0.5
Stationary vibration random, test time	min	30 Each axis (± x / ± y / ± z)
Shock response spectrum, Shock 1 - Curve 4, peak acceleration, 11 ms	m/s <sup>2</sup>	100
Shock response spectrum, Shock 2 – Curve 2, peak acceleration, 6 ms	m/s <sup>2</sup>	300
Number of shocks	-	100 Each axis (± x / ± y / ± z) and direction
Free fall, weight < 20 kg	m (ft)	0.25 (0.82)
Number of free falls	-	2
Toppling, weight < 20 kg	-	Over all edges
Steady-state acceleration	m/s <sup>2</sup>	20
Static load	kPa	5

The controller complies with IEC 61131-2 (mechanical conditions):

Characteristic	Unit	Value
Free fall, weight < 10 kg	m (ft)	1 (3.28)
Number of free falls	-	Once on each face Once on each edge Once on each corner

## Environmental Conditions for Operation

The controller has the degree of protection IP 20. It must only be operated in a control cabinet/enclosure. Refer to Control Cabinet/Enclosure, page 47 for details.

Characteristic	Unit	Value
Installation altitude above mean sea level	m	< 2000
	(ft)	(< 6562)

Ambient temperatures MN660.....1... (narrow housing) without fan kit (accessory, MNAH6AFS01):

Controller	Condition: Without a PCI Express Mini Card
MN660•1.....1...	0 ... 55 °C (32 ... 131 °F)
MN660•2.....1...	0 ... 45 °C (32 ... 113 °F)
MN660•3.....1...	0 ... 45 °C (32 ... 113 °F)
MN660•4.....1...	0 ... 45 °C (32 ... 113 °F)

**NOTE:** In the case of high, application-driven loads, external air conditioning equipment may be required.

Ambient temperatures MN660.....1... (narrow housing) with fan kit (accessory, MNAH6AFS01):

Controller	Condition: With or without a PCI Express Mini Card
MN660.....1...	0 ... 55 °C (32 ... 131 °F)

**NOTE:** In the case of high, application-driven loads, external air conditioning equipment may be required.

Ambient temperatures MN660.....2..... (wide housing) with fan kit:

Controller	Condition: With or without a PCI Express Mini Card and/or a PCI Express Card
MN660.....2.....	0 ... 55 °C (32 ... 131 °F)

**NOTE:** MN660.....2..... controllers are only available with fan kit. In the case of high, application-driven loads, external air conditioning equipment may be required.

The following conditions apply with regard to the ambient temperatures:

Characteristic	Unit	Value
Rate of change of temperature	°C/min	0.5
	(°F/min)	(0.9)
Relative humidity (non-condensing)	%	5 ... 95

The controller complies with class 3M12 as per IEC 60721-3-3 (mechanical conditions):

Characteristic	Unit	Value
Stationary vibration random, acceleration power spectral density, 5 ...200 Hz	(m/s <sup>2</sup> ) <sup>2</sup> / Hz	0.1
Stationary vibration random, test time	min	30 Each axis (± x / ± y / ± z)
Shock	m/s <sup>2</sup>	20
Number of shocks	-	100 Each axis (± x / ± y / ± z)

The controller complies with IEC 61131-2 (mechanical conditions):

Characteristic	Unit	Value
Vibration, sinusoidal, displacement amplitude, 5 ... 8.4 Hz	mm	3.5
Vibration, sinusoidal, acceleration amplitude, 8.4 ... 150 Hz	m/s <sup>2</sup>	10
Vibration, sinusoidal, duration	Cycles	10 1 cycle = 2 sweeps each axis and direction (± x / ± y / ± z)
Shock, peak acceleration	m/s <sup>2</sup>	150
Shock, duration of nominal pulse	ms	11
Shock, number of shocks	-	3 Each axis (± x / ± y / ± z)

# Mechanical Data

## Dimensions MN660.....1... (Narrow Housing)

Front view with mounting plate shown for rear wall mounting:

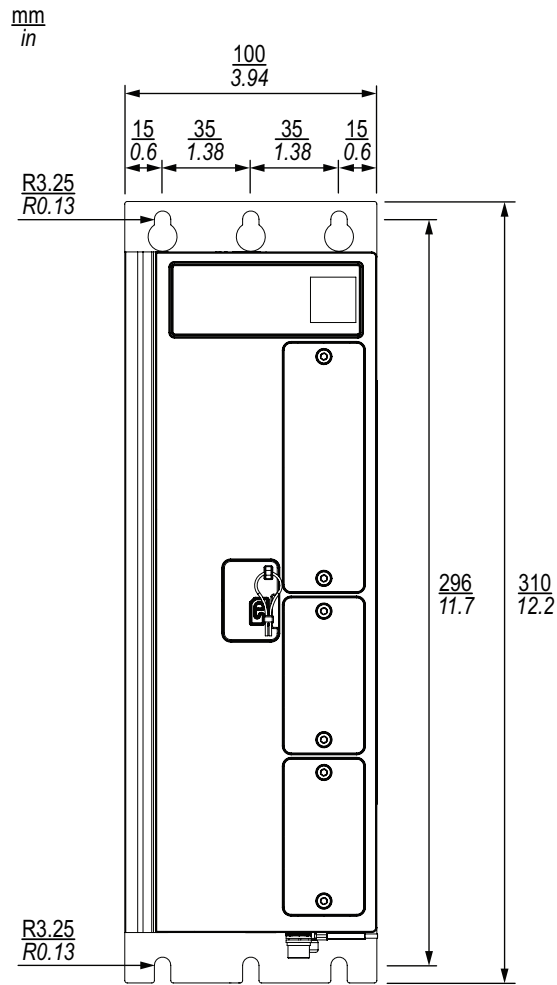

The thickness of the mounting plate is 3 mm (0.12 in).

Side view with mounting plate shown for side wall mounting:

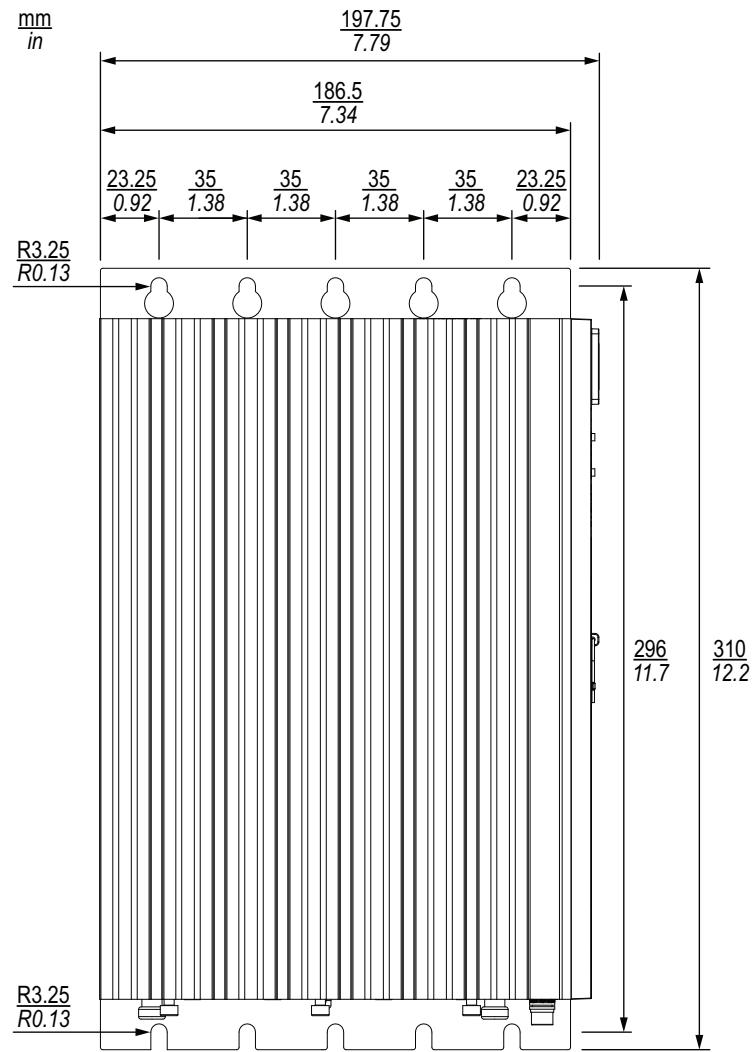

The thickness of the mounting plate is 3 mm (0.12 in).

## Dimensions MN660.....2..... (Wide Housing)

Front view with mounting plate shown for rear wall mounting:

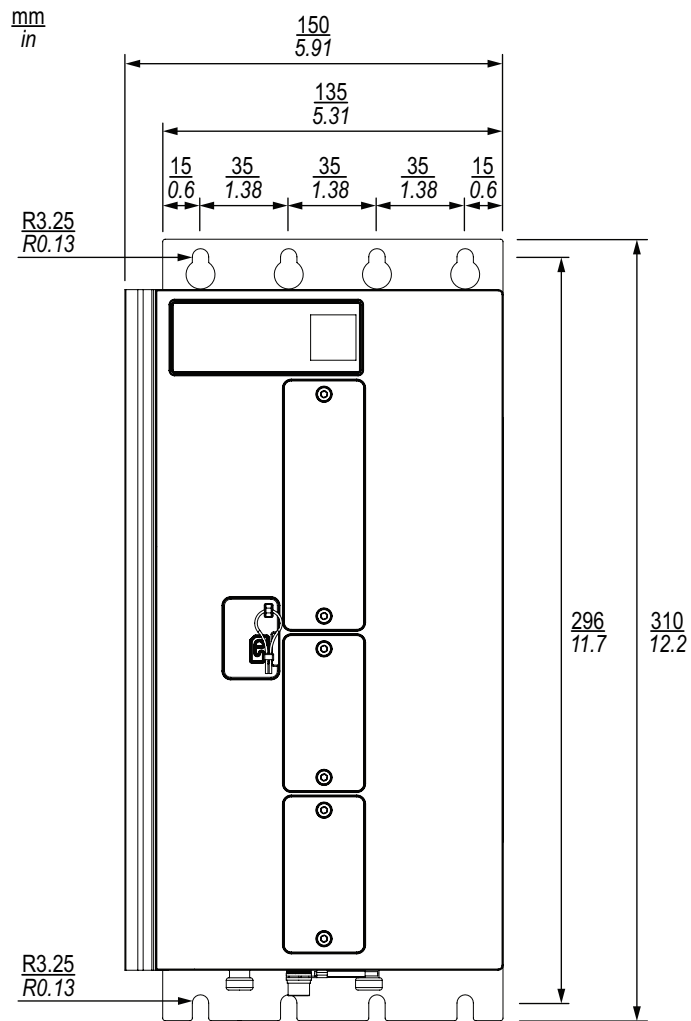

The thickness of the mounting plate is 3 mm (0.12 in).

Side view with mounting plate shown for wall mounting:

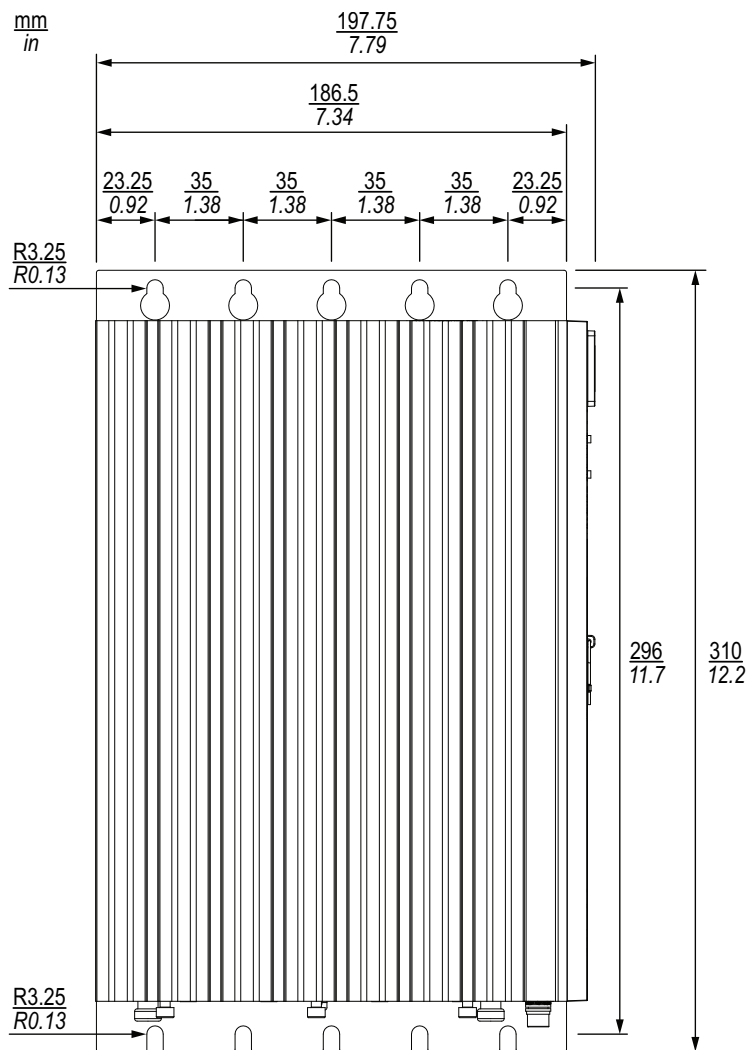

The thickness of the mounting plate is 3 mm (0.12 in).

## Weight

Characteristic	Unit	Value
Maximum weight MN660C without fan kit and without mounting plate <sup>(1)</sup>	kg (lb)	4.65 (10.25)
Maximum weight MN660P without mounting plate <sup>(1)</sup>	kg (lb)	6.0 (13.23)
<sup>(1)</sup> The weight of the controller depends on controller reference.		

## Input Power

The input current of your controller is indicated in the following table and on the nameplate, item Input Device. The value indicated applies to the controller as delivered.

Controller	Input current
MN660C153N1010	1.4 A
MN660C253N1010	1.5 A
MN660C254N1010	2.0 A
MN660C354N2010	2.4 A
MN660C455N2010	3.0 A
MN660P253N2011W0	1.7 A
MN660P254N2012W0	2.2 A
MN660P354N2013W0	2.6 A
MN660P455N2013W0	3.4 A
MN660P455N2023W0	3.6 A

If you install additional equipment in the PCI Express Mini Card (MPCle) slots and/or PCI Express Card (PCle) slots that your controller may feature (refer to *Type Code*, page 21), the input power requirements increase. This also applies if you install an optional fan kit (commercial reference MNAH6AFS01) in a controller originally provided without a fan kit.

The following table lists the additional input power required depending on the equipment installed by you:

Parameter	MPCle slot 1	MPCle slot 2	PCle slot 1	PCle slot 2	Fan kit
Maximum power provided at 3.3 V	3.6 W	3.6 W	8.0 W	8.0 W	-
Maximum power provided at 12.0 V	-	-	8.0 W	8.0 W	2.5 W
Maximum increase of input current at 24 V with reference to current specified on the nameplate	0.17 A	0.17 A	0.77 A	0.77 A	0.12 A

**NOTE:** The increases specified apply without power required by consumers connected to the USB ports and the DisplayPort™. Corresponding increases depend on the power consumption of the connected equipment. For details on the power provided by the USB ports and the DisplayPort™, refer to *USB Ports*, page 42 and to *DisplayPort*, page 45.

**NOTE:** The specified currents relate to the nominal voltage of 24 V. If your power supply unit does not provide the nominal voltage of 24 V, but a different value within the permissible voltage range of -15 % ... +25 % (refer to *Power Supply*, page 36), the currents decrease or increase proportionally.

# Electromagnetic Compatibility

## Immunity

The controller meets the requirements of IEC 61000-4-2 (electrostatic discharge immunity), performance criterion B, for equipment operated in zone B as specified by IEC 61131-2.

The controller meets the requirements of IEC 61000-4-3 (radiated, radio-frequency, electromagnetic field immunity), performance criterion A, for equipment operated in zone B as specified by IEC 61131-2.

The controller meets the requirements of IEC 61000-4-4 (electrical fast transient/burst immunity), performance criterion B, for equipment operated in zone B as specified by IEC 61131-2.

The controller meets the requirements of IEC 61000-4-5 (surge immunity), performance criterion B, for equipment operated in zone B as specified by IEC 61131-2.

The controller meets the requirements of IEC 61000-4-6 (immunity to conducted disturbances, induced by radio-frequency fields), performance criterion A, for equipment operated in zone B as specified by IEC 61131-2.

## Emissions

The controller meets the requirements regarding radiated emission in industrial environments as per IEC 61000-6-4.

The controller meets the requirements regarding conducted emission in industrial environments as per IEC 61000-6-4.

## Power Supply

The controller is supplied by an external 24 Vdc PELV power supply unit.

Characteristic	Value
Nominal input voltage	24 Vdc (-15 % ... +25 %)
Input current	During operation: refer to the nameplate of the controller. The value increases depending on installed additional equipment (for details, refer to Input Power, page 34).  No operation: <15 mA
Maximum AC ripple	+/- 5 %
Maximum inrush current	<15 A for a maximum of 1/240 s
Immunity to input voltage interruption	10 ms (for severity level PS2 as per IEC 61131-2)
Isolation between DC power supply and internal logic	750 Vdc
Isolation between DC power supply and ground	750 Vdc
Overcurrent protection	Yes
Reverse polarity protection	Yes
Surge protection	Yes
Immunity to voltage dips	Yes (slow and fast variation)
Undervoltage detection	Yes (voltage threshold for undervoltage detection is less than or equal to 19 V)
Input monitoring	Yes (voltage and current)
Maximum cable length	30 m (98,43 ft)
Designation on housing	<b>CN1 / 24V DC</b>
Hardware indication of power state	Via LED <b>PWR</b>

Refer to Electrical Installation - Power Supply, page 58 for details on installing the power supply.

## Digital Inputs

Characteristic	Value
Number of inputs	4
Type of input as per IEC 61131-2	Type 1
Isolated	Yes (up to 550 V <sub>rms</sub> )
Filter	15 µs
Logic type	Sink
Overvoltage protection	Yes (surge protection up to 40 V)
Input voltage	24 Vdc (-15% ... +25%)
Input current	~2.5 mA at 24 Vdc nominal
U <sub>IN</sub> low voltage	Typically <12.5 V
U <sub>IN</sub> high voltage	Typically >13.5 V
Protection against reverse polarity	Yes
Maximum cable length	30 m (98.43)
Designation on housing	CN2: <b>P6: DI1, P7: DI2, P8: DI3, P9: DI4, P10: L0</b>
Hardware indication of state of input	Via LEDs <b>DI1, DI2, DI3, DI4</b>

Refer to Electrical Installation - Wiring the Digital Inputs, page 61 for details on wiring.

## Input for Controlling Power On/Power Off/Standby

Characteristic	Value
Number of inputs	1
Type of input as per IEC 61131-2	Type 1
Isolated	Yes (up to 550 V <sub>rms</sub> )
Filter	15 µs
Logic type	Sink
Overvoltage protection	Yes (surge protection up to 40 V)
Input voltage	24 Vdc (-15% ... +25%)
Input current	~2.5 mA at 24 Vdc nominal
U <sub>IN</sub> low voltage	Typically <12.5 V
U <sub>IN</sub> high voltage	Typically >13.5 V
Protection against reverse polarity	Yes
Maximum cable length	30 m (98.43)
Designation on housing	CN2: P4: PWR_REM, P5: PWR_RTN

## Status Output (Watchdog)

Characteristic	Value
Number of outputs	1
Type of output	Relay contact
Isolated	Yes (up to 550 V <sub>rms</sub> )
Switching voltage	24 V
Switching current	1 A maximum (resistive)
Protection	Internal, resettable multifuse
Maximum cable length	30 m (98.43)
Designation on housing	CN2: <b>P1: WD, P2: WD</b>
Hardware indication of state of output	Via LED <b>ERR/WD</b>

Refer to Electrical Installation - Wiring the Status Output (Watchdog), page 63 for details on wiring.

## Ethernet Ports

### Ethernet Ports (LAN)

Characteristic	Value
Number of ports	2 (single port, 2 distinct Ethernet endpoints)
Connector type	RJ45
Maximum cable length	100 m (328.1 ft)
Transmission speed	10BASE-Te 100BASE-TX 1000BASE-T 2.5GBASE-T
Status LED	1 x link/activity 1 x transmission speed
Features	Autonegotiation Auto-MDI/MDIX
Assignment to operating system	CN5, <b>LAN1</b> : VxWorks (MN660C and MN660P) CN6, <b>LAN2</b> : VxWorks (MN660C), Windows (MN660P)
Designation on housing	CN5 ( <b>LAN1</b> ) CN6 ( <b>LAN2</b> )

All M660 controllers are equipped with these two Ethernet ports **LAN1** and **LAN2**.

### Ethernet Ports for Real-Time Ethernet Communication (RTE)

Characteristic	Value
Number of ports	2, 4 or 6, depending on the controller reference (dual port, switched, each pair of <b>RTE P1</b> and <b>RTE P2</b> is one Ethernet endpoint)
Function	Sercos
Connector type	RJ45
Maximum cable length	100 m (328.1 ft)
Transmission speed	10BASE-Te 100BASE-TX 1000BASE-T
Status LED	1 x link/activity per RJ45  For CN8/CN9, the LED <b>RTE</b> is in the status LED panel.  For CN20/CN21 and CN22/CN23, two additional <b>RTE</b> LEDs are displayed by the port themselves.
Features	Sercos Autonegotiation Auto-MDI/MDIX

Characteristic	Value
Assignment to operating system	All RTE ports: VxWorks
Designation on housing	<ul style="list-style-type: none"> <li>• CN8 (RTE P1)</li> <li>• CN9 (RTE P2)</li> <li>• CN20 (RTE P1)</li> <li>• CN21 (RTE P2)</li> <li>• CN22 (RTE P1)</li> <li>• CN23 (RTE P2)</li> </ul>

The number of RTE ports is determined by item 9 of the type code. Refer to Type Code, page 21 for details on M660 controller references.

## USB Ports

Characteristic	Value
Types	<ul style="list-style-type: none"> <li>• USB 3.2 Gen 1 Type-A</li> <li>• USB 3.2 Gen 2 Type-C</li> <li>• USB 2.0 Type-A (internal port, for direct connection of security key or licensing key such as CodeMeter from Wibu with MN660P controllers; internal, reserved in the case of MN660C controllers)</li> </ul>
Maximum cable length	<p>1 m (3,28 ft)</p> <p>3 m (9,84 ft) for connection of USB 2.0 devices and for USB 3.2 Gen 2 Type-C port in DisplayPort alternate mode</p> <p>Direct connection of security key or licensing key for internal USB 2.0 Type-A</p>
Number of ports	<p>MN660C:</p> <ul style="list-style-type: none"> <li>• 2 x USB 3.2 Gen 1 Type-A</li> <li>• 1 x USB 2.0 Type-A (internal, reserved: no function)</li> </ul> <p>MN660P:</p> <ul style="list-style-type: none"> <li>• 2 x USB 3.2 Gen 1 Type-A</li> <li>• 1 x USB 3.2 Gen 2 Type-C</li> <li>• 1 x USB 2.0 Type-A (internal)</li> </ul>
DisplayPort alternate mode	Yes, on CN10
Power	<p>USB 3.2 Gen 1 Type-A: 5 Vdc, 1000 mA</p> <p>USB 3.2 Gen 2 Type-C: 5 Vdc, 12 Vdc, 2500 mA</p> <p>USB 2.0 Type-A: 5 Vdc, 500 mA</p>
Assignment to operating system	<ul style="list-style-type: none"> <li>• CN3, USB 3.2 Gen 1 Type-A: VxWorks (MN660C and MN660P)</li> <li>• CN4, USB 3.2 Gen 1 Type-A: Windows (MN660C), VxWorks (MN660P)</li> <li>• CN10, USB 3.2 Gen 2 Type-C: Windows (MN660P)</li> <li>• USB 2.0 Type-A (internal, no designation on housing): Windows (MN660P)</li> </ul>
Designation on housing	<ul style="list-style-type: none"> <li>• CN3 (<b>USB3 Gen1</b>)</li> <li>• CN4 (<b>USB3 Gen1</b>)</li> <li>• CN10 (<b>USB3 Gen2</b>)</li> </ul>

## PCI Express Card Slots

Controllers of type MN660P.....2..... provide two PCI Express Card slots. Refer to Type Code, page 21 for details on M660 controller types.

Characteristic	Value
Number of slots	2
Number of lanes	PCIe Gen3 x1
Type of socket	Open-ended (can accommodate cards with more lanes)
Maximum card size	Half size cards: <ul style="list-style-type: none"> <li>• Height: 111.15 mm (4.37 in)</li> <li>• Length: 167.65 mm (6.60 in)</li> </ul>
Maximum power	<ul style="list-style-type: none"> <li>• 8 W at 3.3 V</li> <li>• 8 W at 12 V</li> </ul> <p><b>NOTE:</b> Installing cards in the PCI Express slots increases the input current of your controller. For details, refer to Input Power, page 34.</p>
Assignment to operating system	<ul style="list-style-type: none"> <li>• VxWorks (motion control part) if the card is recognized by the controller firmware</li> <li>• Windows (industrial PC part) if the card is not recognized by the controller firmware</li> </ul>

## PCI Express Mini Card Slots

Characteristic	Value
Number of slots	2
Number of lanes	PCIe Gen3 x1
Maximum card size	Full length, full height: <ul style="list-style-type: none"><li>• Height: 30.00 mm (1.81 in)</li><li>• Length: 50.95 mm (2.01 in)</li></ul>
Maximum power	3.6 W at 3.3 V <b>NOTE:</b> Installing cards in the PCI Express Mini slots increases the input current of your controller. For details, refer to Input Power, page 34.
Assignment to operating system	<ul style="list-style-type: none"><li>• VxWorks (motion control part) if the card is recognized by the controller firmware</li><li>• Windows (industrial PC part) if the card is not recognized by the controller firmware</li></ul>

# DisplayPort

Controllers of type MN660P provide a DisplayPort™. Refer to Type Code, page 21 for details on M660 controller types.

Characteristic	Value
Connector type	1 x full size DisplayPort™ connector
Voltage	3.3 V
Current	500 mA
Maximum cable length	3 m (9.84 ft)
Specifications	DisplayPort™ V1.4 Embedded DisplayPort™ V1.4b
Resolutions	1 display 5K at 120 Hz HDR or 8K at 60 Hz HDR 2 displays 8K at 60 Hz SDR or 5K at 60 Hz HDR 3 displays 4K at 60 Hz HDR 4 displays 4K at 60 Hz HDR
Assignment to operating system	Windows
Designation on housing	CN11 (DP)

**NOTE:** The USB 3.2 Type-C port (CN10) provides DisplayPort™ Alternate Mode.

## SD Card Slot

Characteristic	Value
Number of SD card slots	1
Size of SD card	Standard SD card (32.0 × 24.0 × 2.1 mm (1.27 × 0.95 × 0.08 in))
Supported SD cards	SDHC (SD2.0) up to 32 GB
Transfer rate	Up to 50 MByte/s
File system	FAT32
Write protection support	Yes
Assignment to operating system	VxWorks (MN660C and MN660P)
Designation on housing	CN7

# Installation

## Mechanical Installation

### Prerequisites and Requirements

#### Inspecting the Product

Verify the product version by means of the nameplate and the type code, page 21.

Inspect the product for visible damage.

Damaged products may cause electric shock or unintended equipment operation.

 <b>DANGER</b>
<b>ELECTRIC SHOCK OR UNINTENDED EQUIPMENT OPERATION</b>
<ul style="list-style-type: none"><li>• Do not use damaged products.</li><li>• Keep foreign objects (such as chips, screws or wire clippings) from getting into the product.</li></ul>
<b>Failure to follow these instructions will result in death or serious injury.</b>

Contact your local Schneider Electric service representative if you detect any damage whatsoever to the products.

#### Control Cabinet/Enclosure

The controller must only be operated in a control cabinet/enclosure with a minimum IP54 rating.

 <b>WARNING</b>
<b>UNINTENDED EQUIPMENT OPERATION</b>
<ul style="list-style-type: none"><li>• Install and operate the controller in a control cabinet or enclosure that is secured by a keyed or tooled locking mechanism.</li><li>• Verify that the control cabinet or enclosure meets all requirements necessary to operate the controller in the environment and under the conditions specified in the present document.</li></ul>
<b>Failure to follow these instructions can result in death, serious injury, or equipment damage.</b>

The pollution degree of the controller is 2 and the degree of protection is IP 20. The control cabinet or enclosure must be designed in such a way as to meet the corresponding requirements.

The mounting surface in the control cabinet or enclosure must be plane (planarity tolerance: 0.5 mm (0.019 in)) and sufficiently rigid to support the controller under all operating conditions.

The ventilation or air conditioning of the control cabinet or enclosure must be sufficient so that the specified ambient conditions for the controller and the other equipment operated in the control cabinet or enclosure are complied with under all operating conditions. If additional cooling is required, use the optional fan kit (refer to Accessories, page 23).

The efficiency of convection cooling is slightly better if the controller is mounted via its rear wall as compared to its side wall. Refer to Mounting Types, page 51 for details.

## Clearances

The following minimum clearances between the controller and adjacent structures or other equipment are required for rear wall mounting:

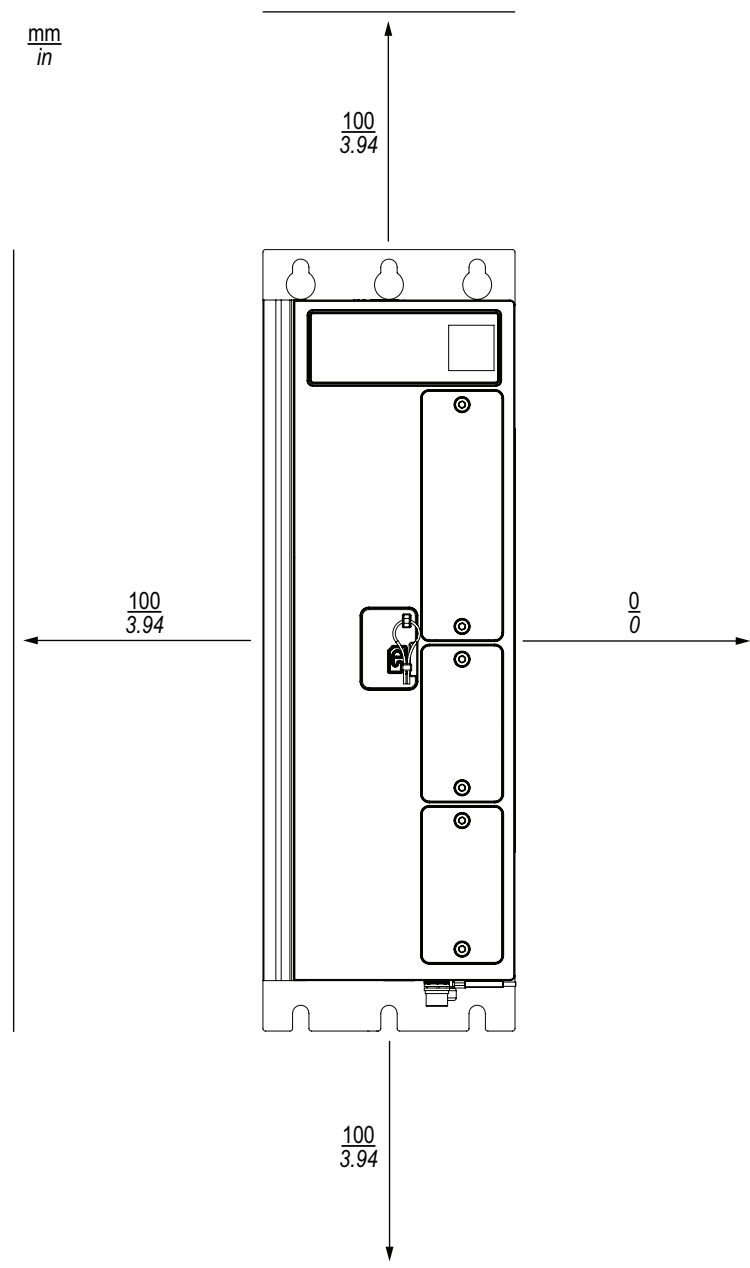

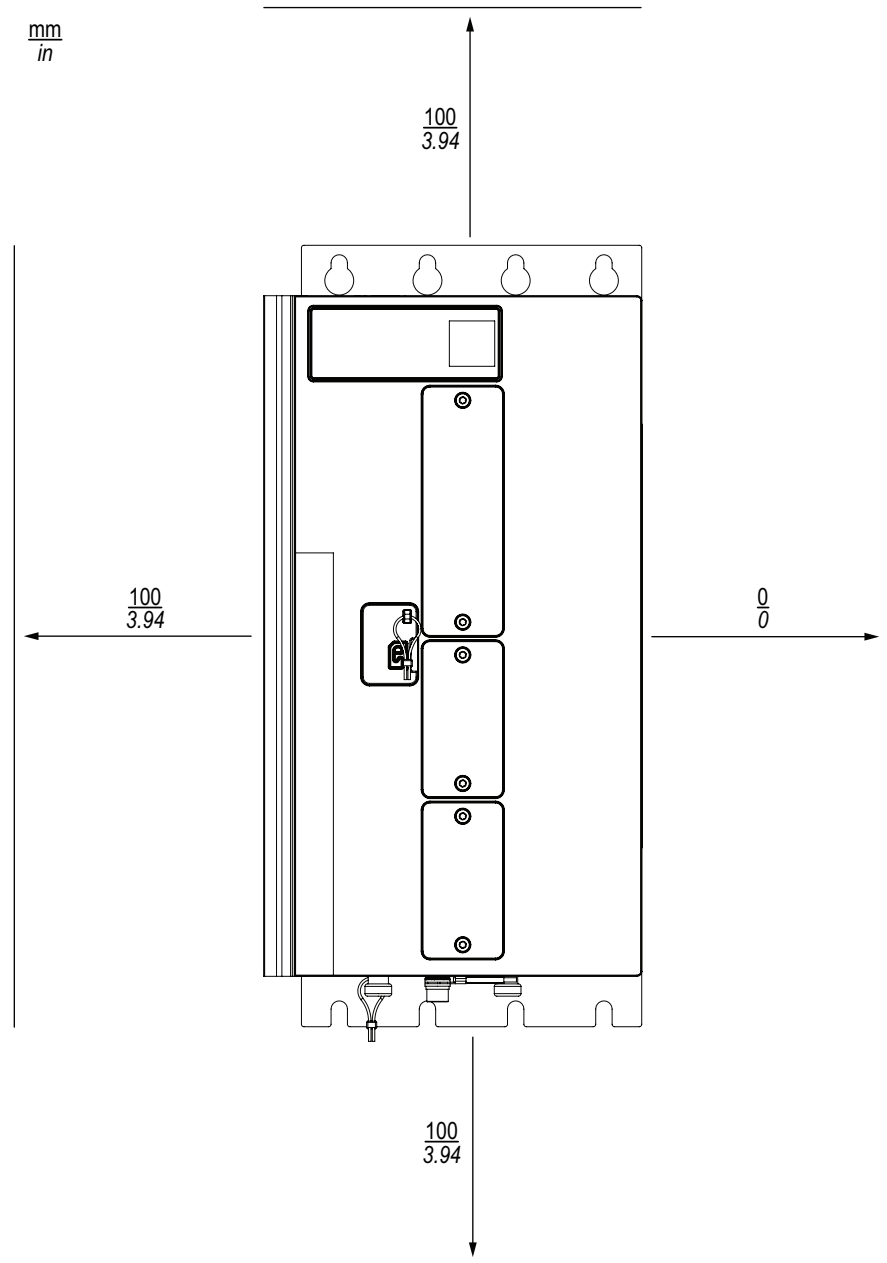

A distance of at least 100 mm (3.94 in) is required between the controller and the door of the control cabinet or enclosure.

The following minimum clearances between the controller and adjacent structures or other equipment are required for side wall mounting:

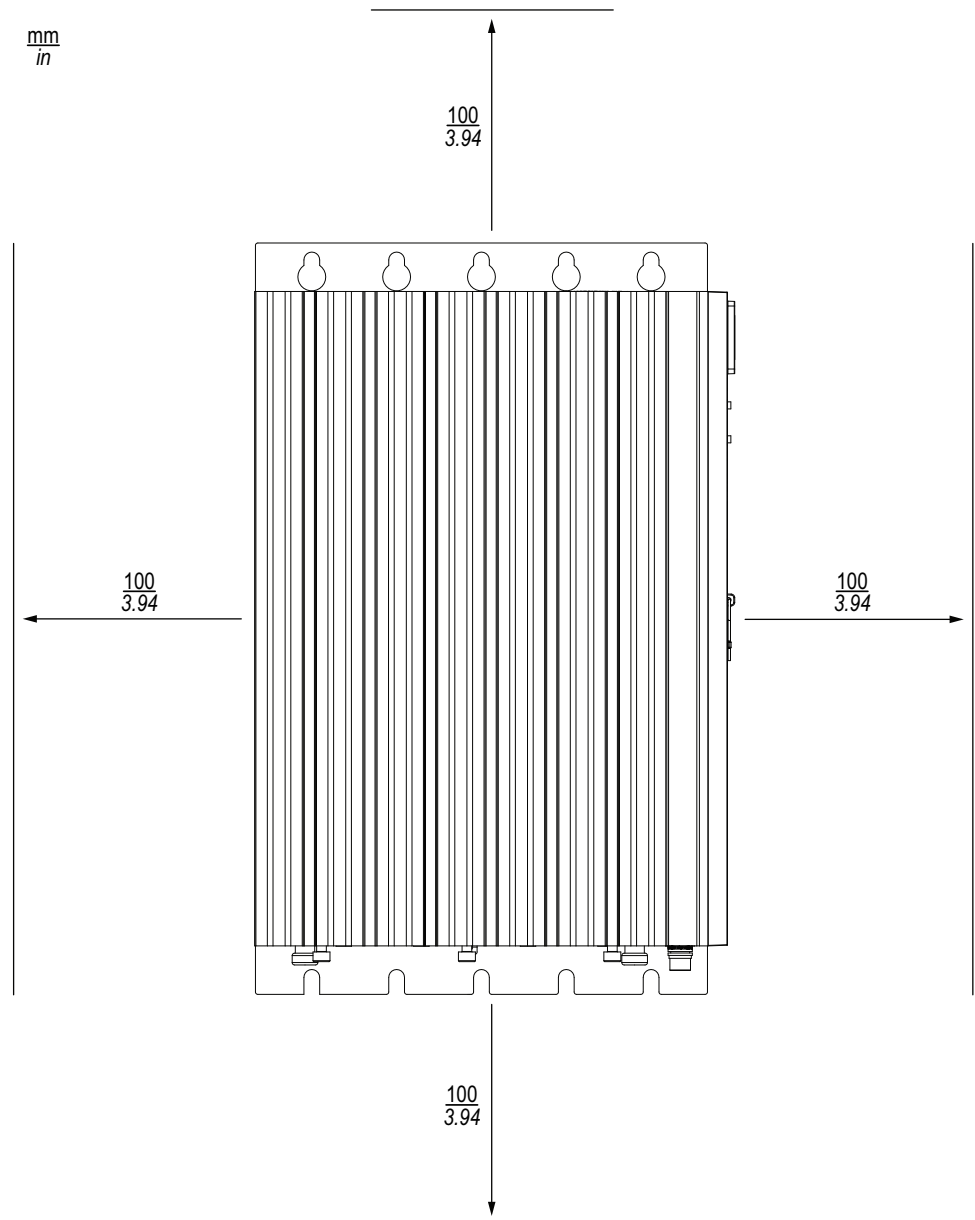

A distance of at least 100 mm (3.94 in) is required between the controller and the door of the control cabinet or enclosure.

# Mounting

## Mounting Types

The controller must be mounted vertically (power supply connector CN1 at the top), regardless of the type of mounting. The controller can be mounted to the mounting surface with its rear wall or its side wall:

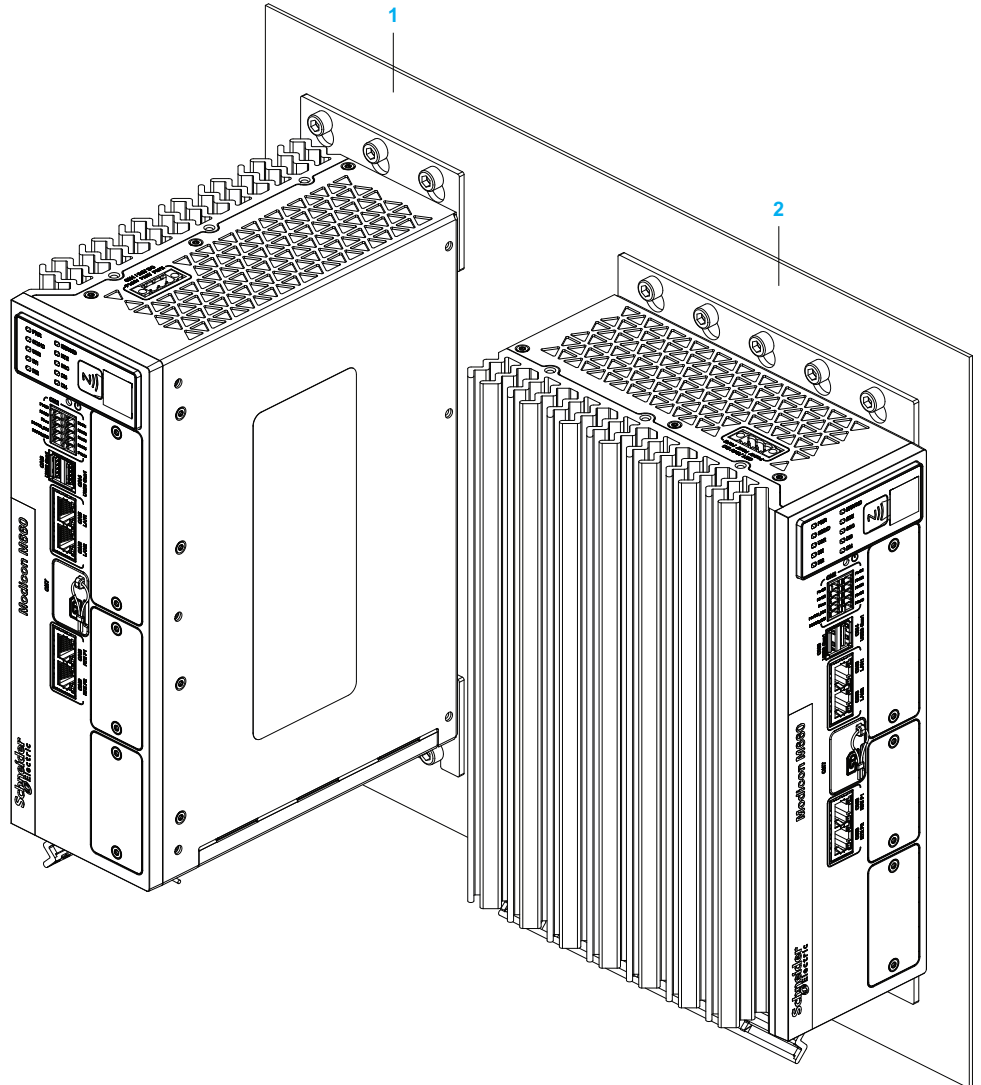

Item	Type of mounting
1	Rear wall mounting
2	Side wall mounting

**NOTE:** The efficiency of convection cooling is slightly better if the controller is mounted via its rear wall as compared to its side wall.

The controller is shipped with two mounting plates for rear wall mounting. An optional mounting kit allows for side wall mounting (refer to *Accessories*, page 23).

## Preparing the Controller for Mounting

Procedure:

Step	Action
1	<p>Rear wall mounting:</p> <ul style="list-style-type: none"> <li>Fit the mounting plate with the holes to the top rear wall of the controller, and align the holes in the mounting plate with the threads in the controller.</li> <li>Fit the mounting plate with the slots to the bottom rear wall of the controller, and align the holes in the mounting plate with the threads in the controller.</li> </ul> <p>Side wall mounting:</p> <ul style="list-style-type: none"> <li>Fit the mounting plate to the side wall of the controller with the slots pointing down, and align the holes in the mounting plate with the threads in the controller.</li> </ul>
2	Screw the mounting plate(s) to the controller using the M4 (TX20) screws supplied with the controller or with the side wall mounting plate with a tightening torque of 2.2 Nm (19.47 lb.in).
3	Verify that you have used screws for all holes in the mounting plate(s).

## Mounting the Controller

The following illustration shows the grid for the drill holes in the mounting surface for rear wall mounting (MN660.....1...):

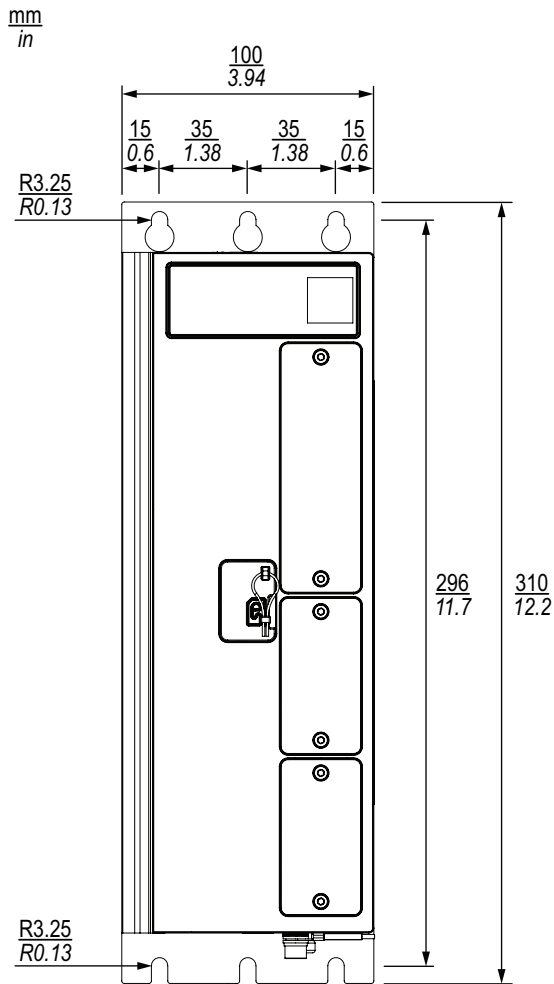

The following illustration shows the grid for the drill holes in the mounting surface for rear wall mounting (MN660.....2.....):

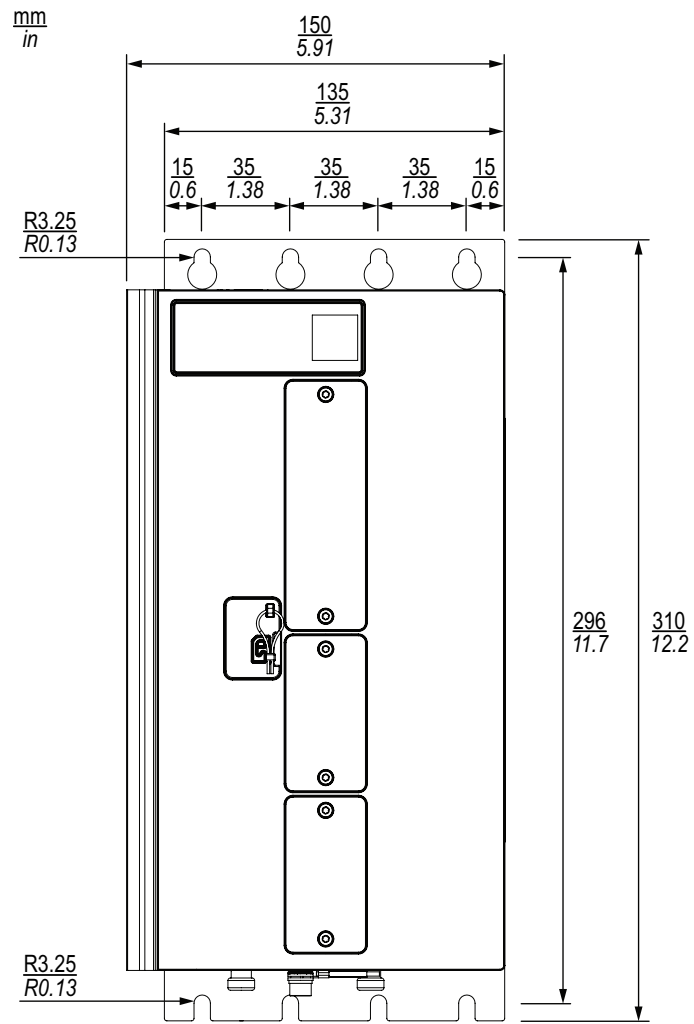

The following illustration shows the grid for the drill holes in the mounting surface for side wall mounting (MN660.....1... and MN660.....2.....):

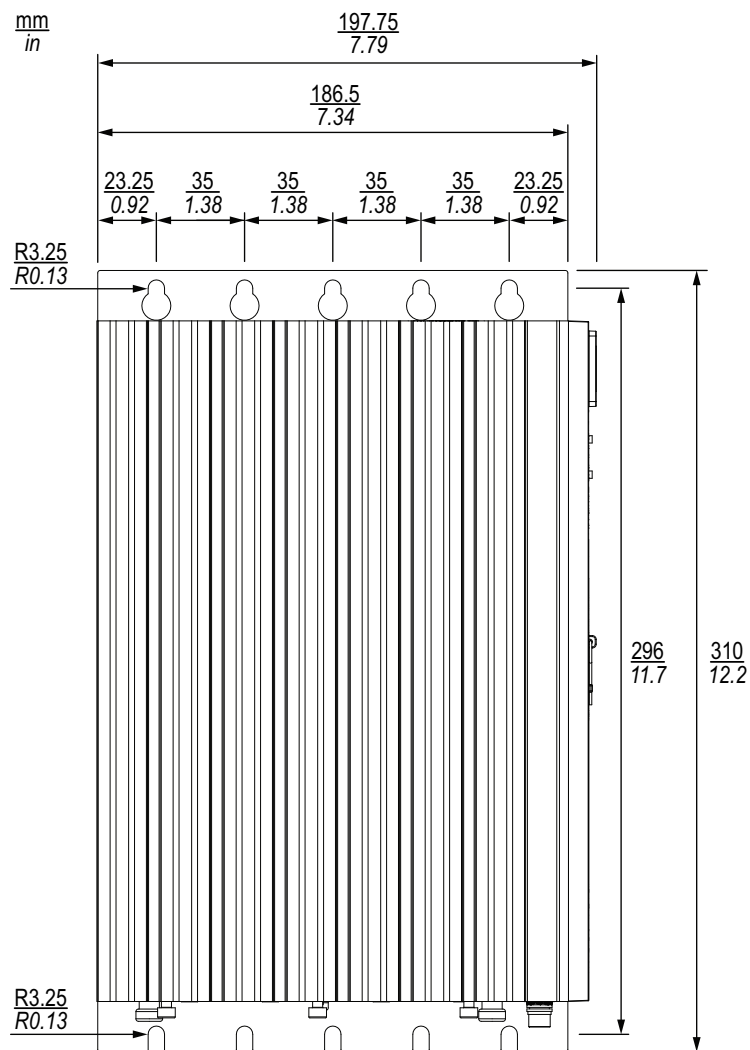

Mounting procedure:

Step	Action
1	Drill holes with a diameter of 6.3 mm into the mounting surface at all positions indicated by the grid illustrations.
2	Screw the controller to the mounting surface using M6 screws and M6 nuts. Secure the nuts with washers (ISO 7093). Use a tightening torque of 5 Nm (44.25 lb.in). The screw length depends on the thickness of the mounting surface.
3	Verify that you have used screws, nuts and washers for all holes.
4	Verify that you have not used washers between the mounting plate of the controller and the mounting surface.
5	If you have used a separate mounting surface, mount the assembly to the rear wall of your control cabinet or enclosure.
6	Verify the mechanical strength and rigidity of the entire assembly.

# Electrical Installation

## Electromagnetic Compatibility

### ⚠ WARNING

#### INSUFFICIENT ELECTROMAGNETIC COMPATIBILITY

- Verify compliance with all EMC regulations and requirements applicable in the country in which the controller and all connected equipment is to be operated, and with all EMC regulations and requirements applicable at the installation site.
- Implement all required interference suppression measures and verify their effectiveness.

**Failure to follow these instructions can result in death, serious injury, or equipment damage.**

The controller is intended for operation in an industrial environment as specified by IEC 61000-6-2 and IEC 61000-6-4, and in zone B as specified by IEC 61131-2. Operating the controller in non-industrial environments such as residential, commercial and light-industrial environments as specified in IEC 61000-6-3 can result in radio interference.

### ⚠ WARNING

#### RADIO INTERFERENCE

- Only install and operate the controller in an industrial environment as specified by IEC 61000-6-2 and IEC 61000-6-4, and in zone B as specified by IEC 61131-2.
- Do not install and operate the controller in public low-voltage mains power networks.

**Failure to follow these instructions can result in death, serious injury, or equipment damage.**

The specified compliance values for electromagnetic compatibility (refer to [Technical Data - Electromagnetic Compatibility, page 35](#)) are only reached in an environment that meets the corresponding requirements. The following guidelines are intended to support you in reducing potential electromagnetic interference in your machine/process. These measures are not exhaustive. Your specific scenario and equipment may require adapted or additional measures.

- Install and operate the controller in a metal control cabinet or enclosure.
- Do not install equipment with high conducted and/or radiated emissions in the same control cabinet or enclosure as the controller.
- Do not install equipment with a susceptibility to conducted and/or radiated emissions that is lower than that of the controller in the same control cabinet or enclosure.
- Ground the control cabinet and its components such as doors, plates, rails, etc.
- Ground the other equipment in the control cabinet as specified.
- Route power cables and communication cables in separate ducts.
- Use shielded cables where specified.
- Ground the shield of communication cables and signal cables where specified.
- Keep cables as short as possible. Do not install unnecessary cable loops.
- If equipotential bonding is required, use conductors with stranded wires.

**NOTE:** Refer to IEC 61131-4 for a list of installation rules that may be able to optimize EMC-related aspects in your machine/process.

## Grounding

Insufficient or improper grounding can cause Electromagnetic Interference (EMI). EMI can lead to communication interruptions and have other adverse effects on the operation of your machine/process.

### **▲ WARNING**

#### **INSUFFICIENT OR IMPROPER GROUNDING**

- Verify that you have properly connected the grounding screw of the controller to an independent grounding point in your system.
- Verify that you have properly connected pin FE of connector CN1 of the controller to an independent grounding point in your system.
- Do not connect grounding wires or grounding cables from the controller to grounding connections of other equipment in your system.
- Verify that there are no ground loops in your system.
- Verify compliance of the grounding of your system with all pertinent codes, standards and regulations applicable at the site of installation of your system.

**Failure to follow these instructions can result in death, serious injury, or equipment damage.**

Multipoint grounding is permissible if connections are made to an equipotential ground plane.

## Grounding Requirements

Characteristic	Value
Connections to be grounded	<ul style="list-style-type: none"> <li>• Grounding screw for functional ground (FE) (designation: functional ground symbol) via separate grounding cable</li> <li>• Pin <b>P3:FE</b> of CN1</li> </ul>
Conductor material grounding cable	Copper, 75 °C (167 °F)
Cross section of grounding conductor	2.5 mm <sup>2</sup> (AWG 14) <ul style="list-style-type: none"> <li>• Grounding screw for functional ground (FE): Minimum 2.5 mm<sup>2</sup> (AWG 14)</li> <li>• Pin <b>P3:FE</b> of CN1: Maximum 2.5 mm<sup>2</sup> (AWG 14)</li> </ul>
Maximum grounding resistance	5 Ω

## Grounding Procedure

Step	Action
1	Connect the other end of the conductor connected to pin <b>P3:FE</b> of CN1 to a separate grounding point in the control cabinet or enclosure.
2	Crimp an M5 cable lug to the controller end of the grounding cable. Use a cable lug of the appropriate size at the other end of the grounding cable.
3	Remove the grounding screw and the washers from the controller.

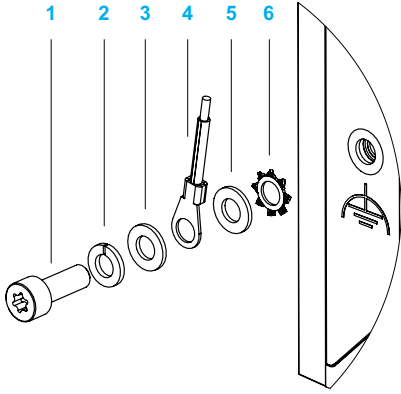
Step	Action
4	<p>Connect the M5 cable lug to the controller using the grounding screw and the washers (tightening torque 2.5 Nm (8.85 lb-in)) as shown below:</p>  <ol style="list-style-type: none"> <li>1. Grounding screw M5</li> <li>2. Spring washer</li> <li>3. Washer</li> <li>4. Cable lug M5</li> <li>5. Washer</li> <li>6. Serrated lock washer</li> </ol>
5	<p>Connect the other end of the grounding cable to a separate grounding point in the control cabinet or enclosure.</p>

# Wiring the Power Supply

## Overview

### DANGER

#### HAZARD OF ELECTRIC SHOCK, EXPLOSION OR ARC FLASH

- Disconnect all power from all equipment including connected devices prior to removing any covers or doors, or installing or removing any accessories, hardware, cables, or wires except under the specific conditions specified in the appropriate hardware guide for this equipment.
- Always use a properly rated voltage sensing device to confirm the power is off where and when indicated.
- Replace and secure all covers, accessories, hardware, cables, and wires and confirm that a proper ground connection exists before applying power to the equipment.
- Use only the specified voltage when operating this equipment and any associated products.

**Failure to follow these instructions will result in death or serious injury.**

### WARNING

#### POTENTIAL OF OVERHEATING AND FIRE

- Do not connect the controller directly to mains voltage.
- Use only isolated PELV power supply units and circuits to supply power to the controller<sup>1</sup>.
- Verify that the wire cross sections and the length of the power supply cable are suitable for the currents specified in the present document and on the nameplate of your controller.

**Failure to follow these instructions can result in death, serious injury, or equipment damage.**

<sup>1</sup> For compliance with UL requirements, the power supply unit must also conform to the criteria of NEC Class 2, and be inherently current-limited to a maximum power output availability of less than 100 VA (approximately 4 A at nominal voltage), or not inherently limited but with an additional protection device such as a circuit breaker or fuse meeting the requirements of clause 9.4 Limited-energy circuit of UL 61010-1. In all cases, the current limit must not exceed that of the electric characteristics and wiring diagrams for the equipment described in the present document. In all cases, the power supply unit must be grounded, and you must separate Class 2 circuits from other circuits. If the indicated rating of the electrical characteristics or wiring diagrams are greater than the specified current limit, multiple Class 2 power supply units may be used.

Insufficient or improper grounding can cause Electromagnetic Interference (EMI). EMI can lead to communication interruptions and have other adverse effects on the operation of your machine/process.

<b>⚠ WARNING</b>
<p><b>INSUFFICIENT OR IMPROPER GROUNDING</b></p> <ul style="list-style-type: none"> <li>• Verify that you have properly connected the grounding screw of the controller to an independent grounding point in your system.</li> <li>• Verify that you have properly connected pin FE of connector CN1 of the controller to an independent grounding point in your system.</li> <li>• Do not connect grounding wires or grounding cables from the controller to grounding connections of other equipment in your system.</li> <li>• Verify that there are no ground loops in your system.</li> <li>• Verify compliance of the grounding of your system with all pertinent codes, standards and regulations applicable at the site of installation of your system.</li> </ul> <p><b>Failure to follow these instructions can result in death, serious injury, or equipment damage.</b></p>

Multipoint grounding is permissible if connections are made to an equipotential ground plane.

The controller is supplied by an external 24 Vdc power supply unit. The power supply unit must meet the following requirements:

- Protective Extra Low Voltage (PELV) power supply unit
- Isolated power supply unit
- Regulated power supply unit if the AC input current is not constant
- No switching elements between the secondary side of the power supply unit and the controller

The power supply input of the controller is equipped with a non-replaceable internal 10 A fuse.

## Wiring Requirements, Wire Cross Sections, Stripping Length

Characteristic	Value
Shielded cable	No
Twisted pair cable	No
Conductor material	Copper, rated for temperatures of 105 °C (221 ° F) or higher
Maximum cable length	30 m (98,43 ft)
Stripping length	10 mm (0.35 in)
Wire cross section, single wire (solid or stranded) without wire ferrule	1.3 ... 2.5 mm <sup>2</sup> (AWG 16 ... 14)
Wire cross section, single wire (stranded) with insulated or uninsulated wire ferrule	1.3 ... 2.5 mm <sup>2</sup> (AWG 16 ...14)
Wire cross section, two wires (stranded) with insulated twin wire ferrule	2 x 1.3 ... 1.5 mm <sup>2</sup> (AWG 2 x 16)

## Wiring the Power Supply Connector CN1

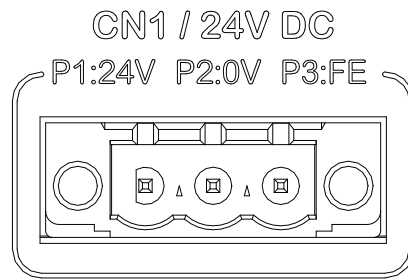

Pins of connector CN1:

Designation	Function
P1:24V	24 Vdc in
P2:0V	0 Vdc in
P3:FE	Functional ground

Refer to Power supply - Technical Data, page 36 for additional information.

## Wiring the Digital Inputs

### ⚠ WARNING

#### INSUFFICIENT AND/OR INEFFECTIVE SAFETY-RELATED FUNCTIONS

- In your risk assessment, verify that the controller meets all requirements regarding the safety-related requirements and capabilities applicable to your machine/process.
- Verify that your risk assessment takes into account all potential consequences that can arise from the controller becoming inoperative.
- Do not use the inputs or the output to implement functions related to functional safety (for example, as per ISO 13849), or as a safety-related function (for example, as per IEC 61800-5-2).
- Use only equipment expressly intended and certified for safety-related purposes to implement safety-related functions.
- During the design as well as during commissioning or recommissioning of the machine/process, verify the correct operation and effectiveness of all safety-related functions and non-safety-related functions by performing comprehensive tests for all operating states, for the defined safe state of your machine/process, and for all potential error situations.
- Verify that your overall machine/process in which the controller is used is properly certified and/or approved according to all standards, regulations, and directives applicable at the installation site of the machine/process.

**Failure to follow these instructions can result in death, serious injury, or equipment damage.**

## Connector Overview CN2

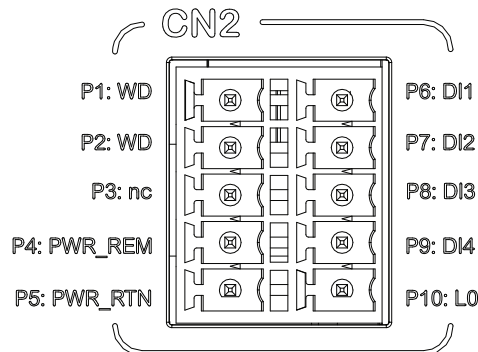

Pin Designation	Signal/Function
P1: WD	Status output (watchdog)
P2: WD	Status output (watchdog)
P3: nc	No connection
P4: PWR_REM	Input for controlling power on/off/standby, 24 V
P5: PWR_RTN	Input for controlling power on/off/standby, 0 V
P6: DI1	Digital input 1
P7: DI2	Digital input 2
P8: DI3	Digital input 3
P9: DI4	Digital input 4
P10: L0	Common for digital inputs

## Wiring the Digital Inputs DI1 ... DI4

Connect the following pins of CN2:

- **P6: DI1**
- **P7: DI2**
- **P8: DI3**
- **P9: DI4**
- **P10: L0**

Ensure proper fusing with a 100 mA type T fuse according to the following wiring diagram:

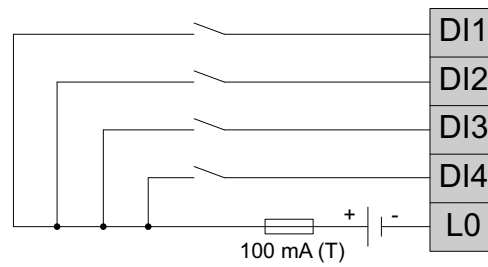

After you have completely wired connector CN2, properly secure the wires in the control cabinet.

## Wiring the Status Output (Watchdog)

### ⚠ WARNING

#### INSUFFICIENT AND/OR INEFFECTIVE SAFETY-RELATED FUNCTIONS

- In your risk assessment, verify that the controller meets all requirements regarding the safety-related requirements and capabilities applicable to your machine/process.
- Verify that your risk assessment takes into account all potential consequences that can arise from the controller becoming inoperative.
- Do not use the inputs or the output to implement functions related to functional safety (for example, as per ISO 13849), or as a safety-related function (for example, as per IEC 61800-5-2).
- Use only equipment expressly intended and certified for safety-related purposes to implement safety-related functions.
- During the design as well as during commissioning or recommissioning of the machine/process, verify the correct operation and effectiveness of all safety-related functions and non-safety-related functions by performing comprehensive tests for all operating states, for the defined safe state of your machine/process, and for all potential error situations.
- Verify that your overall machine/process in which the controller is used is properly certified and/or approved according to all standards, regulations, and directives applicable at the installation site of the machine/process.

**Failure to follow these instructions can result in death, serious injury, or equipment damage.**

## Inductive Loads

The status output is not intended for directly switching inductive loads. For switching inductive loads, you must protect the relay output using additional, certified protective circuits or devices.

Inductive loads can cause contact welding of relay contacts.

### ⚠ WARNING

#### CONTACT WELDING OF RELAY CONTACTS

- Protect the relay output from damage caused by inductive loads using an appropriate external protective circuit or device such as a peak limiter, RC circuit or flyback diode.
- Do not connect the relay output to capacitive loads.

**Failure to follow these instructions can result in death, serious injury, or equipment damage.**

**RC element:** This circuit can be used for both AC and DC load power circuits.

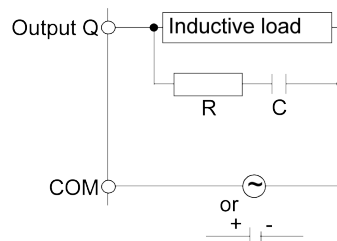

**C** Value from 0.1 to 1  $\mu$ F

**R** Resistor of approximately the same resistance value as the load

**Diode:** This circuit can be used for DC load power circuits.

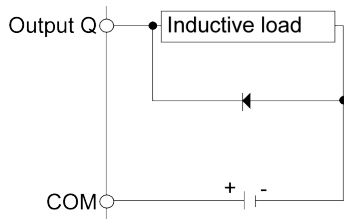

Use a diode with the following ratings:

- Reverse withstand voltage: power voltage of the load circuit x 10.
- Forward current: more than the load current.

**Varistor:** This circuit can be used for both AC and DC load power circuits.

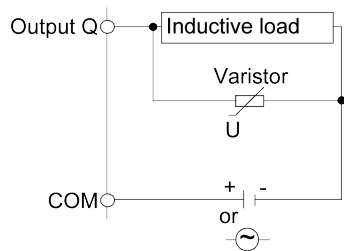

In applications where the inductive load is switched on and off frequently and/or rapidly, ensure that the continuous energy rating (J) of the varistor exceeds the peak load energy by 20 % or more.

## Connector Overview CN2

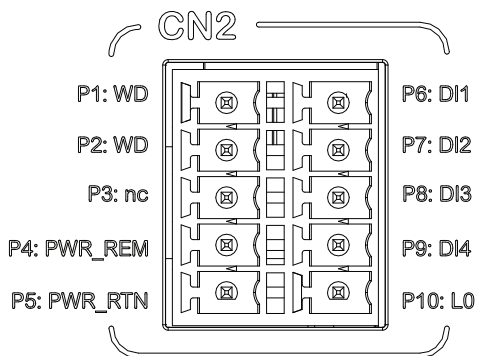

Pin Designation	Signal/Function
P1: WD	Status output (watchdog)
P2: WD	Status output (watchdog)
P3: nc	No connection
P4: PWR_REM	Input for controlling power on/off/standby, 24 V
P5: PWR_RTN	Input for controlling power on/off/standby, 0 V
P6: DI1	Digital input 1
P7: DI2	Digital input 2
P8: DI3	Digital input 3
P9: DI4	Digital input 4
P10: L0	Common for digital inputs

## Cable Requirements, Wire Cross Sections, Stripping Length

Characteristic	Value
Shielded cable	No
Twisted pair cable	No
Conductor material	Copper, 75 °C (167 °F)
Maximum cable length	30 m (98.43 ft)
Stripping length	9 mm (0.35 in)
Wire cross section, single wire (solid or stranded) without wire ferrule	1.0 ... 1.5 mm <sup>2</sup> (AWG 17 ... 16)
Wire cross section, single wire (stranded) with uninsulated wire ferrule	1.0 ... 1.5 mm <sup>2</sup> (AWG 17 ... 16)

### Wiring the Status Output (Watchdog)

Connect the following pins at CN2 to an appropriate output device:

- **P1: WD**
- **P2: WD**

After you have completely wired connector CN2, bundle the cables connected to CN2 and secure them properly in the control cabinet.

# Wiring the Input for Controlling Power On/Off/Standby

## Connector Overview CN2

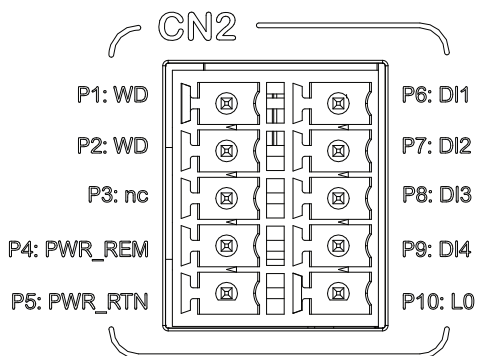

Pin Designation	Signal/Function
P1: WD	Status output (watchdog)
P2: WD	Status output (watchdog)
P3: nc	No connection
P4: PWR_REM	Input for controlling power on/off/standby, 24 V
P5: PWR_RTN	Input for controlling power on/off/standby, 0 V
P6: DI1	Digital input 1
P7: DI2	Digital input 2
P8: DI3	Digital input 3
P9: DI4	Digital input 4
P10: L0	Common for digital inputs

## Wiring Requirements, Wire Cross Sections, Stripping Length

Characteristic	Value
Shielded cable	No
Twisted pair cable	No
Conductor material	Copper, 75 °C (167 °F)
Maximum cable length	30 m (98.43 ft)
Stripping length	9 mm (0.35 in)
Wire cross section, single wire (solid or stranded) without wire ferrule	0.5 ... 1.5 mm <sup>2</sup> (AWG 20 ... 16)
Wire cross section, single wire (stranded) with uninsulated wire ferrule	0.5... 1.5 mm <sup>2</sup> (AWG 20 ... 16)
Wire cross section, single wire (stranded) with insulated wire ferrule	0.5 ... 0.75 mm <sup>2</sup> (AWG 20 ... 18)

Connect the following pins at CN2 to an appropriate input device:

- **P4: PWR\_REM**
- **P5: PWR\_RTN**

Ensure proper fusing with a 100 mA type T fuse according to the following wiring diagram:

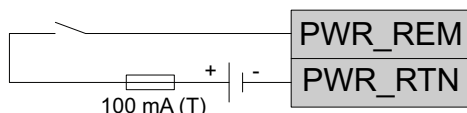

After you have completely wired connector CN2, bundle the cables connected to CN2 and secure them properly in the control cabinet.

**▲ WARNING**

**UNINTENDED EQUIPMENT OPERATION**

Verify that your machine/process is in a defined safe state before changing the power state of the controller.

**Failure to follow these instructions can result in death, serious injury, or equipment damage.**

## Installation of Accessories

### Installation of an Optional Fan Kit

#### General Information

<b>⚡⚠ DANGER</b>
<p><b>HAZARD OF ELECTRIC SHOCK, EXPLOSION OR ARC FLASH</b></p> <ul style="list-style-type: none"> <li>• Disconnect all power from all equipment including connected devices prior to removing any covers or doors, or installing or removing any accessories, hardware, cables, or wires except under the specific conditions specified in the appropriate hardware guide for this equipment.</li> <li>• Always use a properly rated voltage sensing device to confirm the power is off where and when indicated.</li> <li>• Replace and secure all covers, accessories, hardware, cables, and wires and confirm that a proper ground connection exists before applying power to the equipment.</li> <li>• Use only the specified voltage when operating this equipment and any associated products.</li> </ul> <p><b>Failure to follow these instructions will result in death or serious injury.</b></p>

<b>⚠ CAUTION</b>
<p><b>HOT SURFACES</b></p> <ul style="list-style-type: none"> <li>• Avoid unprotected contact with hot surfaces.</li> <li>• Verify that the heat sink has cooled down before performing work on the controller.</li> </ul> <p><b>Failure to follow these instructions can result in injury or equipment damage.</b></p>

<b>NOTICE</b>
<p><b>ELECTROSTATIC DISCHARGE</b></p> <p>Take the necessary protective measures against electrostatic discharge before attempting to open the housing of the controller.</p> <p><b>Failure to follow these instructions can result in equipment damage.</b></p>

The fan kit is available as an accessory (commercial reference MNAH6AFS01 for MN660•••••••1••• controllers, refer to [Accessories and Spare Parts](#), page 23). It allows you to improve the heat dissipation in the controller.

The fan kit consists of a fan plate with two fans attached to it. This fan plate replaces the bottom plate of the controller.

### Installing an Optional Fan Kit

Procedure:

Step	Action
1	Remove power from the controller and from all connected equipment.
2	Touch the housing or ground connection of the controller (not the power supply) to discharge electrostatic charge from your body.
3	If the housing has been sealed via the sealing lug, cut the sealing wire and remove the seal.

Step	Action
4	Remove the two knurled screws at the bottom plate of the controller.
5	Remove the bottom plate.
6	Push the connectors of the fans into the white connector sockets on the printed circuit board. No specific order is required because both fans are switched simultaneously.
7	Fit the fan plate into position.
8	Fasten the fan plate with the two knurled screws.
9	Mount a new housing seal, if required.
10	Verify correct operation of all equipment.

Fan monitoring is not enabled by default for controllers that are not factory-equipped with a fan kit. After installing the fan kit, enable fan monitoring in Ecostruxure Automation Expert - Motion. Refer to the *Modicon M660 Motion Controller Programming Guide*, page 9 for details. Do not enable fan monitoring if no fan kit is installed.

## Uninstalling and Reinstalling a Fan Kit

Certain activities such as installing PCI Express cards or PCI Express Mini Card modules or cards require you to temporarily uninstall the fan kit for access to the controller housing and to reinstall it to complete the installation.

Procedure:

Step	Action
1	Remove power from the controller and from all connected equipment.
2	Touch the housing or ground connection of the controller (not the power supply) to discharge electrostatic charge from your body.
3	If the housing has been sealed via the sealing lug, cut the sealing wire and remove the seal.
4	Remove the two (MN660*****1***) or four (MN660*****2*****) knurled screws at the bottom of the controller.
5	Remove the fan plate with the fan assembly and disconnect the two fan cables.
6	Perform the steps required to install the equipment in the PCI Express Mini Card slots or the PCI Express Card slots. For details, refer to <i>Installation of PCI Express Mini Card Module or Card</i> , page 75 and <i>Installation of PCI Express Cards</i> , page 83.
7	Reconnect the two fan cables. Ensure the connectors are securely inserted in their connectors.
8	Refit and tighten the two (MN660*****1***) or four (MN660*****2*****) knurled screws at the bottom of the controller.
9	Mount a new housing seal, if required.
10	Verify correct operation of all equipment.

# Installation of a Buffer Battery

## General Information

### DANGER

#### HAZARD OF ELECTRIC SHOCK, EXPLOSION OR ARC FLASH

- Disconnect all power from all equipment including connected devices prior to removing any covers or doors, or installing or removing any accessories, hardware, cables, or wires except under the specific conditions specified in the appropriate hardware guide for this equipment.
- Always use a properly rated voltage sensing device to confirm the power is off where and when indicated.
- Replace and secure all covers, accessories, hardware, cables, and wires and confirm that a proper ground connection exists before applying power to the equipment.
- Use only the specified voltage when operating this equipment and any associated products.

**Failure to follow these instructions will result in death or serious injury.**

### DANGER

#### EXPLOSION, FIRE, OR CHEMICAL BURNS

- Replace with identical battery type.
- Follow all the instructions of the battery manufacturer.
- Remove all replaceable batteries before discarding unit.
- Recycle or properly dispose of used batteries.
- Protect battery from any potential short-circuit.
- Do not recharge, disassemble, heat above 100 °C (212 °F), or incinerate.
- Use your hands or insulated tools to remove or replace the battery.
- Maintain proper polarity when inserting and connecting a new battery.

**Failure to follow these instructions will result in death or serious injury.**

### CAUTION

#### HOT SURFACES

- Avoid unprotected contact with hot surfaces.
- Verify that the heat sink has cooled down before performing work on the controller.

**Failure to follow these instructions can result in injury or equipment damage.**

### NOTICE

#### ELECTROSTATIC DISCHARGE

Take the necessary protective measures against electrostatic discharge before attempting to open the housing of the controller.

**Failure to follow these instructions can result in equipment damage.**

A capacitor in the controller is used to buffer the CMOS (BIOS settings), the real-time clock and the non-volatile memory for a period of up to 14 days. An optional buffer battery extends this period to at least three years. If these periods elapse without the controller having been powered on, the corresponding data is lost.

<b>NOTICE</b>
<p><b>LOSS OF DATA</b></p> <ul style="list-style-type: none"> <li>• If the controller will be powered off for more than 14 days, install the optional buffer battery.</li> <li>• Verify that the settings of the real-time clock and the values in the non-volatile memory are correct each time you power on the controller before you start the application.</li> </ul> <p><b>Failure to follow these instructions can result in equipment damage.</b></p>

The buffer battery is available as an accessory (commercial reference VW3E6020 refer to [Accessories and Spare Parts](#), page 23).

The lithium metal cell is used as a buffer for the CMOS (BIOS settings), the real-time clock and the non-volatile memory. If no buffer battery is installed, a capacitor in the controller provides the energy to keep the data for a period of up to 14 days. If the buffer battery is used, this period is extended to at least three years. A monitoring function alerts you to an empty buffer battery.

## Installing/Replacing a Buffer Battery

Procedure:

Step	Action
1	Verify that the buffer battery you are going to install is a genuine Schneider Electric accessory, commercial reference VW3E6020.
2	Remove power from the controller and from all connected equipment.
3	Touch the housing or ground connection of the controller (not the power supply) to discharge electrostatic charge from your body.
4	If the housing has been sealed via the sealing lug, cut the sealing wire and remove the seal.
5	Remove the two (MN660*****1***) or four (MN660*****2*****) knurled screws at the bottom of the controller.
6	Controller without fan kit: <ul style="list-style-type: none"> <li>• Remove the bottom plate.</li> </ul> Controller with fan kit: <ul style="list-style-type: none"> <li>• Remove the fan plate with the fan assembly and disconnect the two fan cables.</li> </ul>
7	To install a buffer battery, align it with the slot in the battery holder and slide it into the slot.  To replace a buffer battery, first pull out the empty buffer battery. Then align the new buffer battery with the slot in the battery holder and slide it into the slot.
8	Controller without fan kit: <ul style="list-style-type: none"> <li>• Refit the bottom plate into position.</li> </ul> Controller with fan kit: <ul style="list-style-type: none"> <li>• Reconnect the two fan cables. Ensure the connectors are securely inserted in their connectors.</li> <li>• Refit the fan plate with the fan assembly into position.</li> </ul>
9	Refit and tighten the two (MN660*****1***) or four (MN660*****2*****) knurled screws at the bottom of the controller.
10	Mount a new housing seal, if required.

After installing or replacing the buffer battery, make the battery-related settings in Ecostruxure Automation Expert - Motion. Verify that the settings for the real-time clock of the controller are correct. Verify that the settings for the buffer battery are

correct. Refer to the Modicon M660 Motion Controller Programming Guide, page 9 for details.

# Installation of a USB Security Key

## General Information

M660 controllers are equipped with an internal USB 2.0 Type-A port (refer to Technical Data - USB Ports, page 42 for details).

The USB 2.0 Type-A port is available after you have removed the bottom plate of the controller. It is intended for security or licensing keys such as CodeMeter from Wibu under Windows for the industrial PC of an MN660P motion controller. Such keys allow you to implement security or software licensing features on the industrial PC of the controller.

The maximum length of a USB key that can be connected to the internal USB 2.0 Type-A port is 35.5 mm (1.39 in). Connect the USB key directly to the internal USB 2.0 Type-A port without using a cable. Do not use the USB 2.0 Type-A port for other purposes.

The USB 2.0 Type-A is not available under VxWorks.

## Installing a USB Security Key

<b>⚠️⚠️ DANGER</b>
<b>HAZARD OF ELECTRIC SHOCK, EXPLOSION OR ARC FLASH</b>
<ul style="list-style-type: none"><li>• Disconnect all power from all equipment including connected devices prior to removing any covers or doors, or installing or removing any accessories, hardware, cables, or wires except under the specific conditions specified in the appropriate hardware guide for this equipment.</li><li>• Always use a properly rated voltage sensing device to confirm the power is off where and when indicated.</li><li>• Replace and secure all covers, accessories, hardware, cables, and wires and confirm that a proper ground connection exists before applying power to the equipment.</li><li>• Use only the specified voltage when operating this equipment and any associated products.</li></ul>
<b>Failure to follow these instructions will result in death or serious injury.</b>

<b>⚠️ CAUTION</b>
<b>HOT SURFACES</b>
<ul style="list-style-type: none"><li>• Avoid unprotected contact with hot surfaces.</li><li>• Verify that the heat sink has cooled down before performing work on the controller.</li></ul>
<b>Failure to follow these instructions can result in injury or equipment damage.</b>

<b>NOTICE</b>
<b>ELECTROSTATIC DISCHARGE</b>
Take the necessary protective measures against electrostatic discharge before attempting to open the housing of the controller.
<b>Failure to follow these instructions can result in equipment damage.</b>

Procedure:

Step	Action
1	Remove power from the controller and from all connected equipment.
2	Touch the housing or ground connection of the controller (not the power supply) to discharge electrostatic charge from your body.
3	If the housing has been sealed via the sealing lug, cut the sealing wire and remove the seal.
4	Remove the two (MN660*****1***) or four (MN660*****2*****) knurled screws at the bottom of the controller.
5	Controller without fan kit: <ul style="list-style-type: none"> <li>• Remove the bottom plate.</li> </ul> Controller with fan kit: <ul style="list-style-type: none"> <li>• Remove the fan plate with the fan assembly and disconnect the two fan cables.</li> </ul>
6	Insert the USB key into the USB 2.0 Type-A port (do not use a USB cable).
7	Controller without fan kit: <ul style="list-style-type: none"> <li>• Refit the bottom plate into position.</li> </ul> Controller with fan kit: <ul style="list-style-type: none"> <li>• Reconnect the two fan cables. Ensure the connectors are securely inserted in their connectors.</li> <li>• Refit the fan plate with the fan assembly into position.</li> </ul>
8	Refit and tighten the two (MN660*****1***) or four (MN660*****2*****) knurled screws at the bottom of the controller.
9	Mount a new housing seal, if required.

# Installation of PCI Express Mini Card Module or Card

## Introduction

<b>⚡⚠ DANGER</b>
<p><b>HAZARD OF ELECTRIC SHOCK, EXPLOSION OR ARC FLASH</b></p> <ul style="list-style-type: none"> <li>• Disconnect all power from all equipment including connected devices prior to removing any covers or doors, or installing or removing any accessories, hardware, cables, or wires except under the specific conditions specified in the appropriate hardware guide for this equipment.</li> <li>• Always use a properly rated voltage sensing device to confirm the power is off where and when indicated.</li> <li>• Replace and secure all covers, accessories, hardware, cables, and wires and confirm that a proper ground connection exists before applying power to the unit.</li> <li>• Use only the specified voltage when operating this equipment and any associated products.</li> </ul> <p><b>Failure to follow these instructions will result in death or serious injury.</b></p>

Installing unsuitable equipment in the PCI Express Mini Card or PCI Express Card slots of your controller can lead to unwanted impacts on the controller such as, but not limited to, increases in the operating temperature or power consumption, or introduction of electromagnetic interference (EMI). This can result in hazards.

<b>⚠ WARNING</b>
<p><b>UNINTENDED EQUIPMENT OPERATION</b></p> <ul style="list-style-type: none"> <li>• Prior to installing equipment in the PCI Express Mini Card or PCI Express Card slots of your controller, perform a risk assessment as per ISO 12100 and/or other equivalent assessment that takes into account all potential consequences that can arise from the installation of such equipment.</li> <li>• Verify that the equipment is suitable for industrial use and operation in the environments specified in the present document.</li> <li>• Verify that none of the technical characteristics and limit values specified in the present document are exceeded as a result of the installation of the equipment such as, but not limited to, electrical data and Electromagnetic Compatibility (EMC).</li> <li>• After installation of the equipment, commission or recommission the machine/process in which the controller is used pursuant to all regulations, standards, and process definitions applicable to your machine/process.</li> <li>• Verify correct operation and effectiveness of all functions by performing comprehensive tests for all operating states, the defined safe state, and all potential error situations.</li> </ul> <p><b>Failure to follow these instructions can result in death, serious injury, or equipment damage.</b></p>

<b>⚠ CAUTION</b>
<p><b>HOT SURFACES</b></p> <ul style="list-style-type: none"> <li>• Avoid unprotected contact with hot surfaces.</li> <li>• Verify that the heat sink has cooled down before performing work on the controller.</li> </ul> <p><b>Failure to follow these instructions can result in injury or equipment damage.</b></p>

## NOTICE

### ELECTROSTATIC DISCHARGE

Take the necessary protective measures against electrostatic discharge before attempting to open the housing of the controller.

**Failure to follow these instructions can result in equipment damage.**

M660 controllers provide two PCI Express Mini Card slots and two associated openings in the housing that allow you to install PCI Express Mini Card modules that feature external interfaces. Originally, the openings are covered with blind plates as long as no PCI Express Mini Card modules are installed.

Two types of PCI Express Mini Cards are available:

1. PCI Express Mini Card modules with external interfaces, for example, RJ45 connectors. They consist of the following components:
  - PCI Express Mini card: This card is inserted into the PCI Express Mini Card slot.
  - Connector board: This component consists of a board with the external interfaces, for example, RJ45 connectors.
  - Ribbon cable: The ribbon cable connects the PCI Express Mini Card and the connector board.
  - Screws: The screws are used to hold the PCI Express Mini Card.
2. PCI Express Mini Cards without external interfaces, for example, AI accelerator cards. They consist of the following components:
  - PCI Express Mini Card: This card is inserted into the PCI Express Mini Card slot.
  - Screws: The screws are used to hold the PCI Express Mini Card.

A PCI Express Mini Card slot provides a maximum power of 3.6 W at a voltage of 3.3 V. For technical data, refer to *PCI Express Mini Card Slots*, page 44. For information on the input power increase with installed PCI Express Mini Cards, refer to *Input Power*, page 34.

PCI Express Mini Cards that are recognized by the firmware of the controller are made available under VxWorks (motion control part). If you install a PCI Express Mini Card that is not recognized by the firmware of the controller, it is made available under Windows (industrial PC part, MN660P controllers only).

## Installing a PCI Express Mini Card Module or Card

If you want to install a PCI Express Mini Card module or card in a controller already installed and commissioned, disconnect all wiring from the controller and remove it from the control cabinet prior to starting the installation procedure. Label the cables and wires to facilitate re-installation.

The following description presents the installation of a PCI Express Mini Card module in slot 1 (MN660.....1...: item 13, front view, MN660.....2....., item 13, front view).

**NOTE:** For installing a PCI Express Mini Card module in slot 2, use PCI Express Mini Card slot 2 on the board of the controller and the opening in the controller housing for slot 2 (item 12). Do not confuse Mini Card slot 1 and Mini Card slot 2.

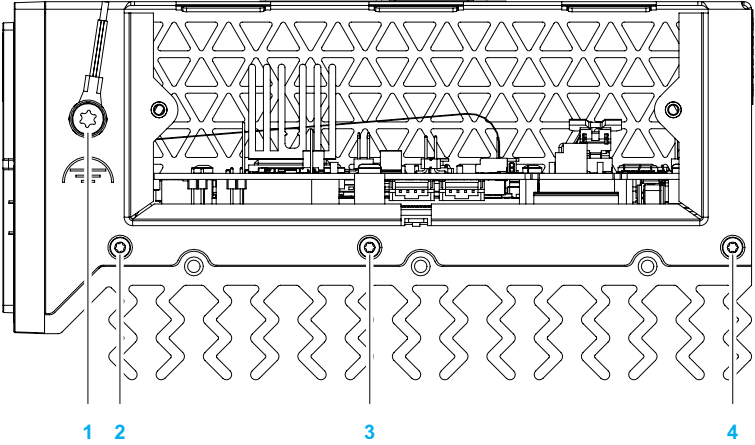
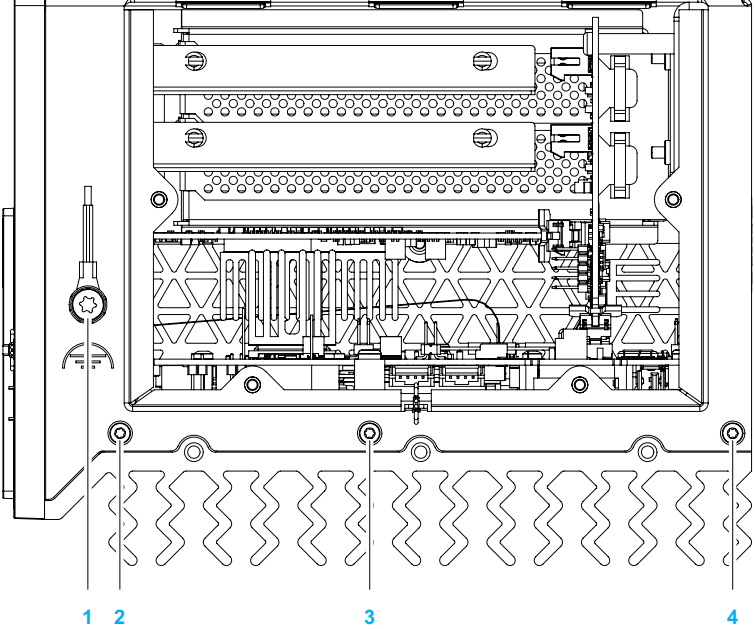
Step	Action
1	If your controller is equipped with a fan kit, remove the fan kit. For details, refer to Uninstalling and Reinstalling a Fan Kit, page 69.
2	Remove the mounting plate(s). For details, refer to Preparing the Controller for Mounting, page 51. Invert the sequence of steps of the procedure described.
3	<p>At the bottom of the controller, remove the grounding screw (1).</p> <p>Remove the screws (2), (3) and (4).</p> <p>MN660.....1...:</p>  <p>MN660.....2.....:</p> 

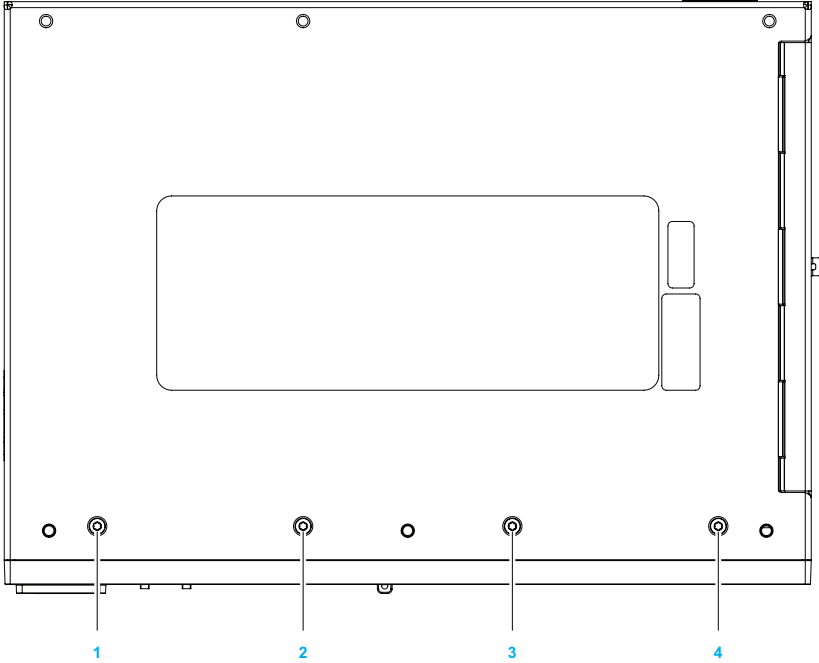
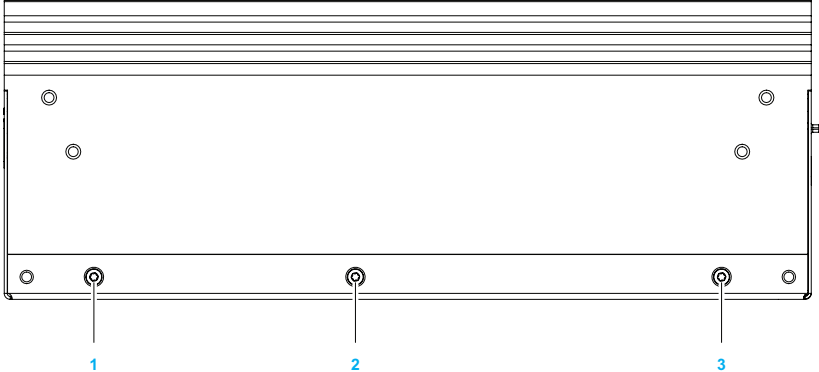
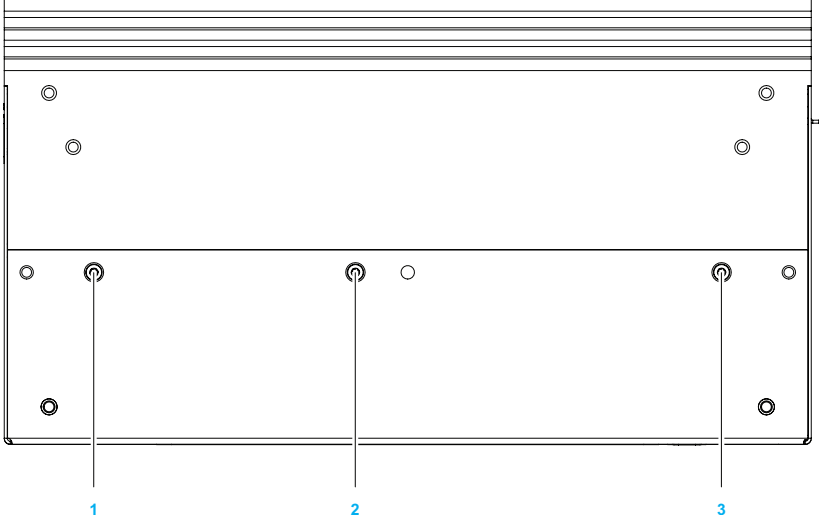
Step	Action
4	<p data-bbox="614 174 1182 206">At the typeplate side, remove the screws (1), (2), (3) and (4).</p> 
5	<p data-bbox="614 907 1098 938">At the backside, remove the screws (1), (2) and (3).</p> <p data-bbox="614 952 778 983">MN660.....1...:</p>  <p data-bbox="614 1400 794 1431">MN660.....2.....:</p> 

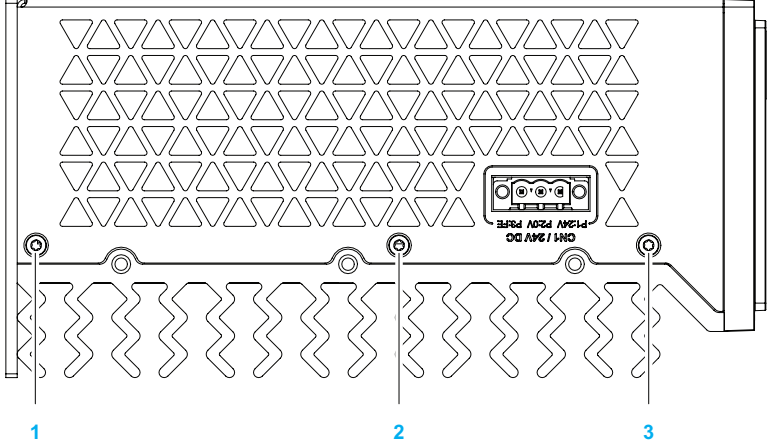
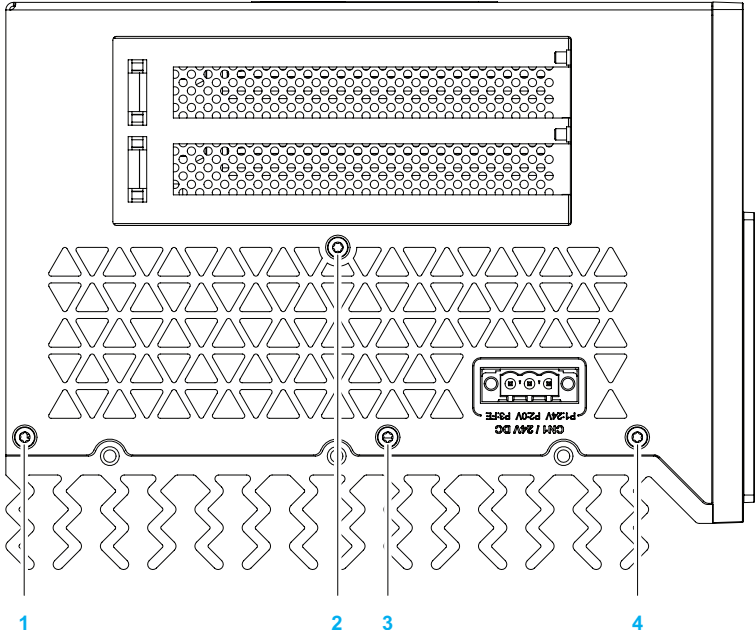
Step	Action
6	<p>MN660.....1...:</p> <p>At the top of the controller, remove the screws (1), (2) and (3).</p> 
	<p>MN660.....2.....:</p> <p>At the top of the controller, remove the screws (1), (2), (3) and (4).</p> 

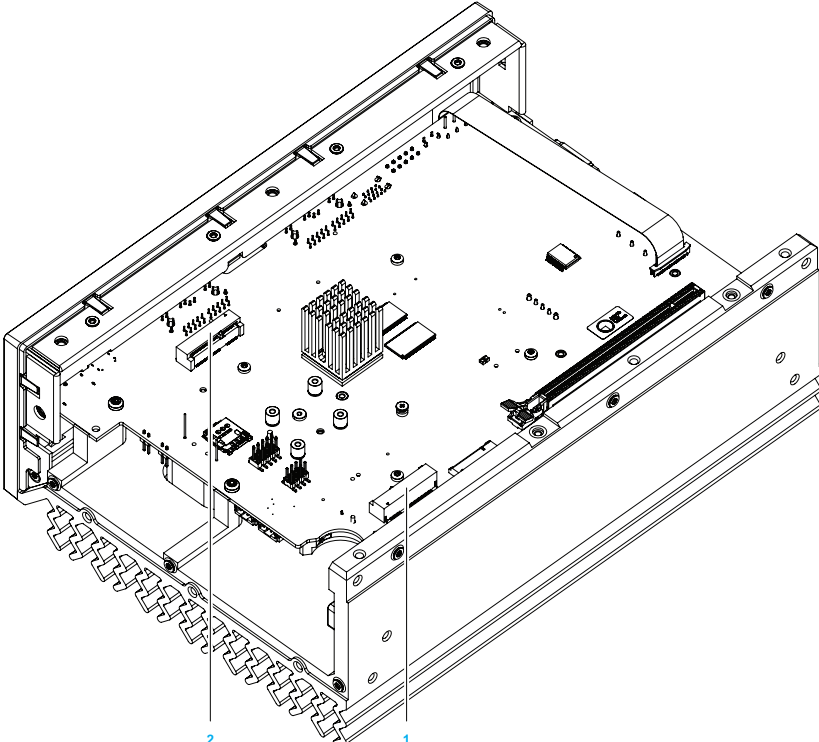
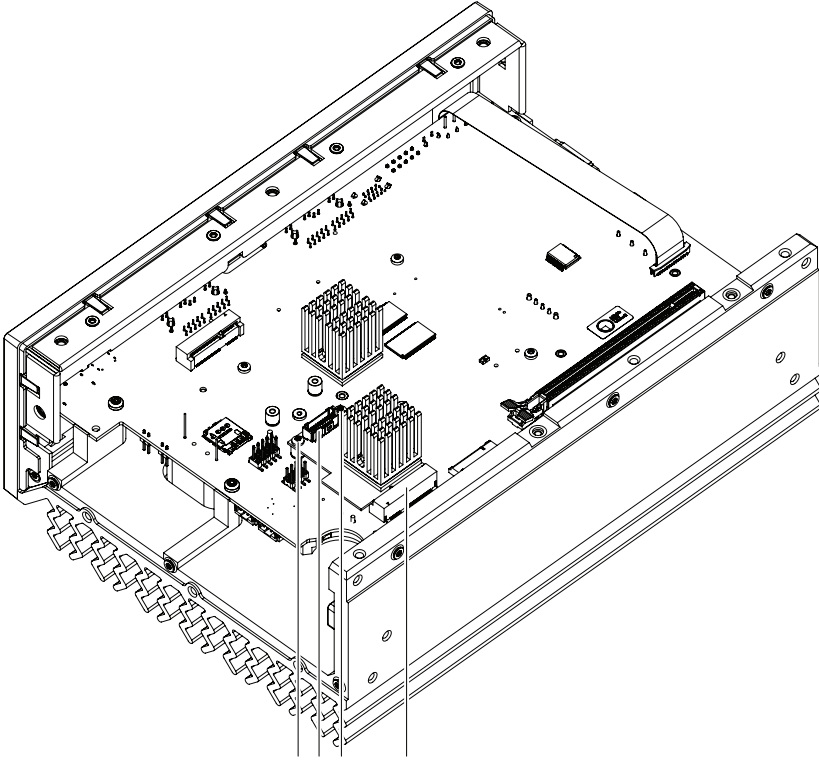
Step	Action
7	<p>Lift the U-shaped cover off of the controller housing. You can now access the PCI Express Mini Card slot 1 (1) and Mini Card slot 2 (2) on the board.</p> 
8	<p>Slide the PCI Express Mini Card into the PCI Express Mini Card slot (1) on the board of the controller.</p> <p>Fasten the PCI Express Mini Card with the two screws (2) and (3) delivered with the PCI Express Mini Card module (tightening torque 0.43 Nm (3.81 lb.in)).</p> <p>If the PCI Express Mini Card does not have an external interface, continue with step 14, page 82.</p>  <p><b>NOTE:</b> Do not connect the ribbon cable to the connector of the PCI Express Mini Card (4) at this point.</p>

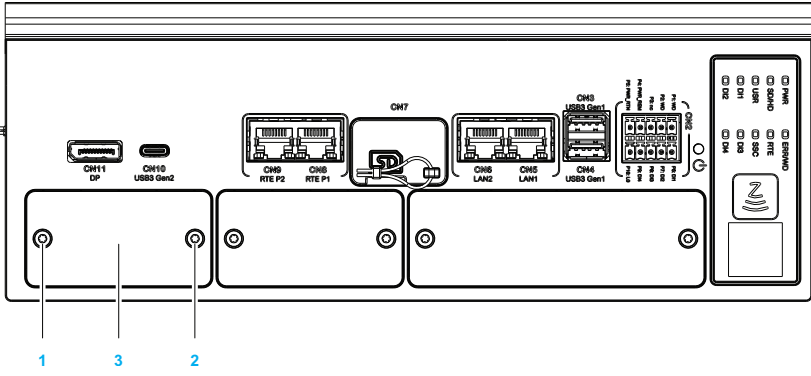
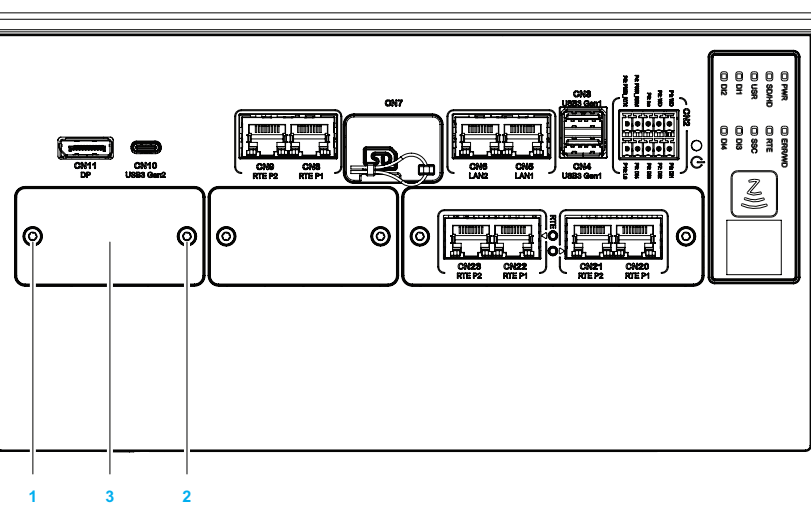
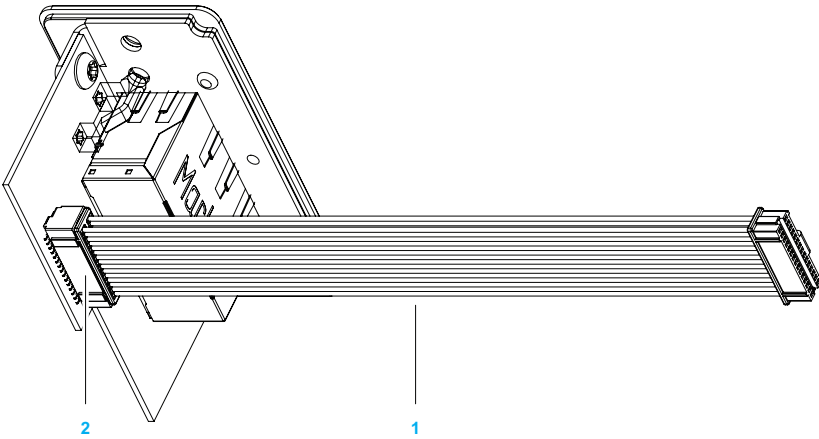
Step	Action
<p>9</p>	<p>On the front of the controller, remove the screws (1) and (2) and the blind plate (3) from the opening in the controller housing for slot 1.</p> <p>MN660.....1...:</p>  <p>MN660.....2.....:</p> 
<p>10</p>	<p>Connect the ribbon cable (1) to the connector board (2).</p> 

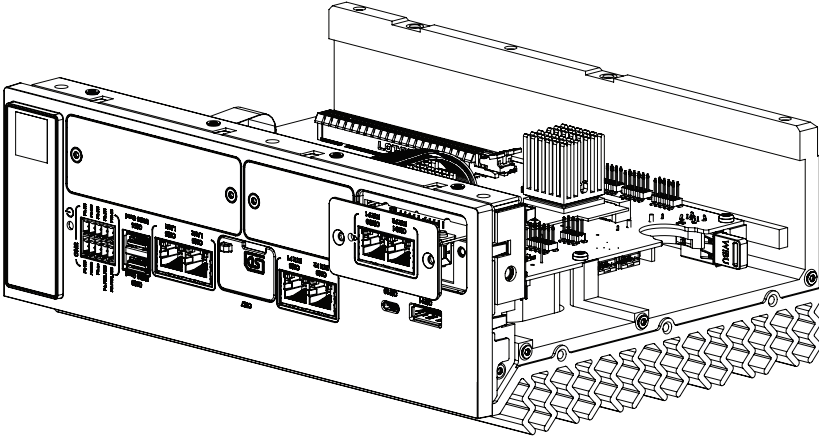
Step	Action
11	<p>Slide the ribbon cable from the outside of the controller through the opening for slot 1 into the controller housing and fit the plate with the connector board into the opening.</p> 
12	Fasten the plate of the connector board with the two screws removed in step 9, page 81 (tightening torque 0.82 Nm (7.26 lb.in)).
13	Connect the ribbon cable to the connector (4) on the PCI Express Mini Card shown in step 8, page 80.
14	Verify the correct connection of the components.
15	Refit the U-shaped cover of the controller housing removed in step 7, page 80.
16	<p>Refit the screws removed in step 6, page 79.</p> <p>Tightening torque MN660*****1***:</p> <ul style="list-style-type: none"> <li>• Screws 1, 2, 3: 0.82 Nm (7.26 lb.in)</li> </ul> <p>Tightening torques MN660*****2*****:</p> <ul style="list-style-type: none"> <li>• Screws 1, 3, 4: 0.82 Nm (7.26 lb.in)</li> <li>• Screw 2: 0.43 Nm (0.38 lb.in)</li> </ul>
17	Refit the screws 1, 2 and 3 removed in step 5, page 78 (tightening torque 0.82 Nm (7.26 lb.in)).
18	Refit the screws 1, 2, 3 and 4 removed in step 4, page 78 (tightening torque 0.82 Nm (7.26 lb.in)).
19	Refit the screws 2, 3, and 4 removed in step 3, page 77 (tightening torque 0.82 Nm (7.26 lb.in)).
20	Refit the grounding screw 1 also removed in step 3, page 77. For further details, refer to Grounding Procedure, page 56.
21	Refit the mounting plate(s) removed in step 2, page 77. For further details, refer to Preparing the Controller for Mounting, page 51.
22	If applicable, refit the fan kit removed in step 1, page 77. For further details, refer to Uninstalling and Reinstalling a Fan Kit, page 69.

After having installed the PCI Express Mini Card module or card, install and commission the controller. For details, refer to Installation, page 47 and Commissioning, page 89.

The firmware of the controller automatically detects that a new PCI Express Mini Card module or card has been installed. PCI Express Mini Cards that are recognized by the firmware of the controller are made available under VxWorks (motion control part). If you install a PCI Express Mini Card that is not recognized by the firmware of the controller, it is made available under Windows (industrial PC part, MN660P controllers only).

# Installation of PCI Express Cards

## Introduction

<b>⚡⚠ DANGER</b>
<b>HAZARD OF ELECTRIC SHOCK, EXPLOSION OR ARC FLASH</b>
<ul style="list-style-type: none"> <li>• Disconnect all power from all equipment including connected devices prior to removing any covers or doors, or installing or removing any accessories, hardware, cables, or wires except under the specific conditions specified in the appropriate hardware guide for this equipment.</li> <li>• Always use a properly rated voltage sensing device to confirm the power is off where and when indicated.</li> <li>• Replace and secure all covers, accessories, hardware, cables, and wires and confirm that a proper ground connection exists before applying power to the unit.</li> <li>• Use only the specified voltage when operating this equipment and any associated products.</li> </ul>
<b>Failure to follow these instructions will result in death or serious injury.</b>

Installing unsuitable equipment in the PCI Express Mini Card or PCI Express Card slots of your controller can lead to unwanted impacts on the controller such as, but not limited to, increases in the operating temperature or power consumption, or introduction of electromagnetic interference (EMI). This can result in hazards.

<b>⚠ WARNING</b>
<b>UNINTENDED EQUIPMENT OPERATION</b>
<ul style="list-style-type: none"> <li>• Prior to installing equipment in the PCI Express Mini Card or PCI Express Card slots of your controller, perform a risk assessment as per ISO 12100 and/or other equivalent assessment that takes into account all potential consequences that can arise from the installation of such equipment.</li> <li>• Verify that the equipment is suitable for industrial use and operation in the environments specified in the present document.</li> <li>• Verify that none of the technical characteristics and limit values specified in the present document are exceeded as a result of the installation of the equipment such as, but not limited to, electrical data and Electromagnetic Compatibility (EMC).</li> <li>• After installation of the equipment, commission or recommission the machine/process in which the controller is used pursuant to all regulations, standards, and process definitions applicable to your machine/process.</li> <li>• Verify correct operation and effectiveness of all functions by performing comprehensive tests for all operating states, the defined safe state, and all potential error situations.</li> </ul>
<b>Failure to follow these instructions can result in death, serious injury, or equipment damage.</b>

<b>⚠ CAUTION</b>
<b>HOT SURFACES</b>
<ul style="list-style-type: none"> <li>• Avoid unprotected contact with hot surfaces.</li> <li>• Verify that the heat sink has cooled down before performing work on the controller.</li> </ul>
<b>Failure to follow these instructions can result in injury or equipment damage.</b>

## NOTICE

### ELECTROSTATIC DISCHARGE

Take the necessary protective measures against electrostatic discharge before attempting to open the housing of the controller.

**Failure to follow these instructions can result in equipment damage.**

MN660P.....2..... controllers provide two PCI Express Card slots that allow you to install PCI Express cards.

A PCI Express Card slot provides a maximum power of 8 W at a voltage of 3.3 V and of 12 V. For technical data, refer to PCI Express Card Slots, page 43. For information on the input power increase with installed PCI Express Cards, refer to Input Power, page 34.

PCI Express Cards that are recognized by the firmware of the controller are made available under VxWorks (motion control part). If you install a PCI Express Card that is not recognized by the firmware of the controller, it is made available under Windows (industrial PC part).

## Installing a PCI Express Card

If you want to install a PCI Express Card in a controller already installed and commissioned, disconnect all wiring from the controller and remove it from the control cabinet prior to starting the installation procedure. Label the cables and wires to facilitate re-installation.

The following description presents the installation of a PCI Express Card in the lower slot (the slot closest to the heat sink). It is a best practice to install the first PCI Express card in the lower slot. If you want to install a second PCI Express card at a later point in time, you can access the upper slot (without having to remove the first PCI Express card).

Step	Action
1	Remove the fan kit from your controller. For details, refer to Uninstalling and Reinstalling a Fan Kit, page 69.
2	Remove the mounting plate. For details, refer to Preparing the Controller for Mounting, page 51. Invert the sequence of steps of the procedure described.
3	At the bottom of the controller, remove the grounding screw (1). Remove the screws (2), (3) and (4).

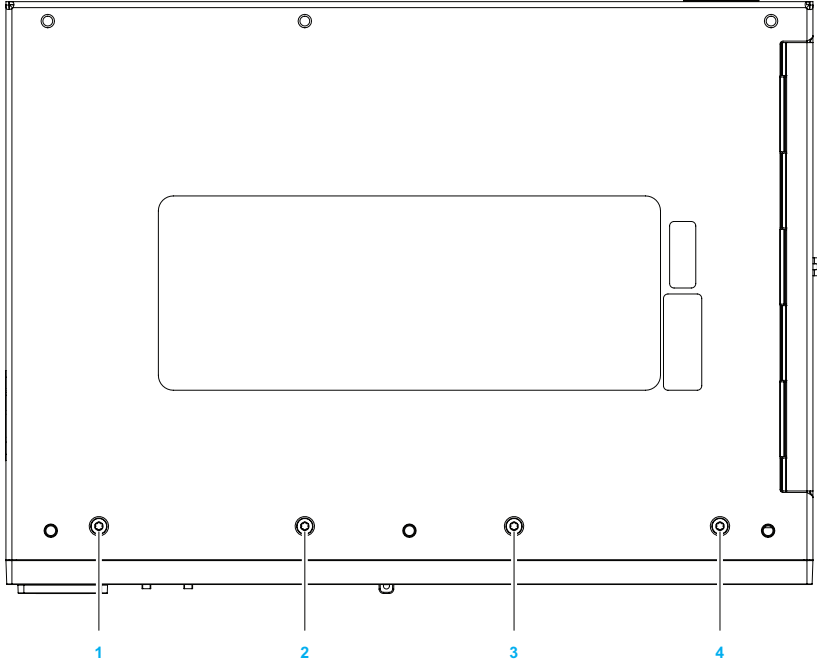
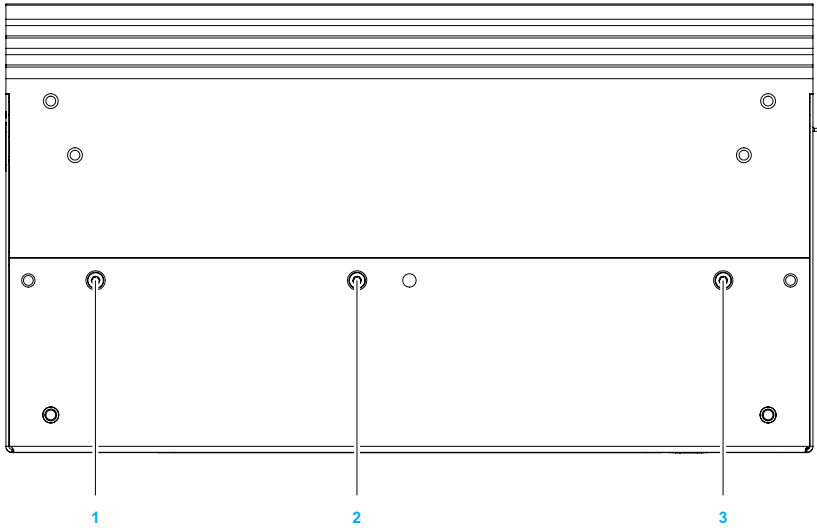
Step	Action
4	<p data-bbox="638 174 1204 206">At the typeplate side, remove the screws (1), (2), (3) and (4).</p> 
5	<p data-bbox="638 907 1117 938">At the backside, remove the screws (1), (2) and (3).</p> 

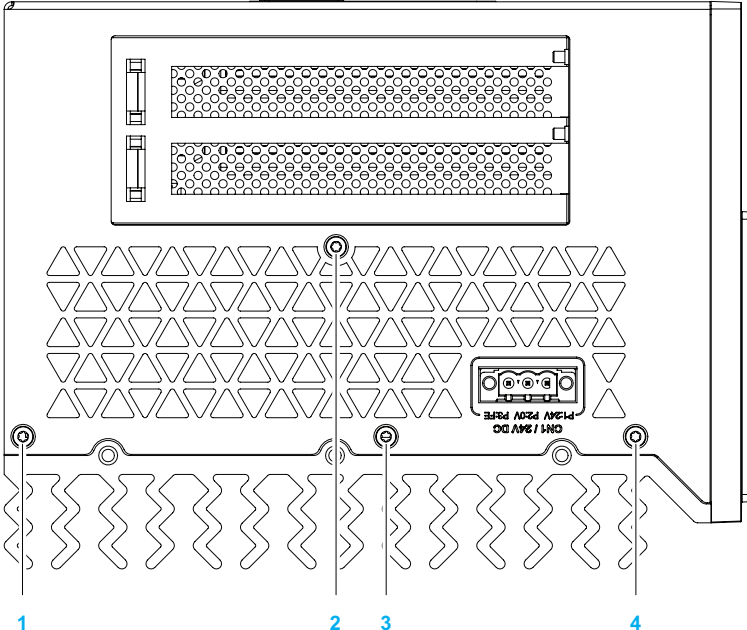
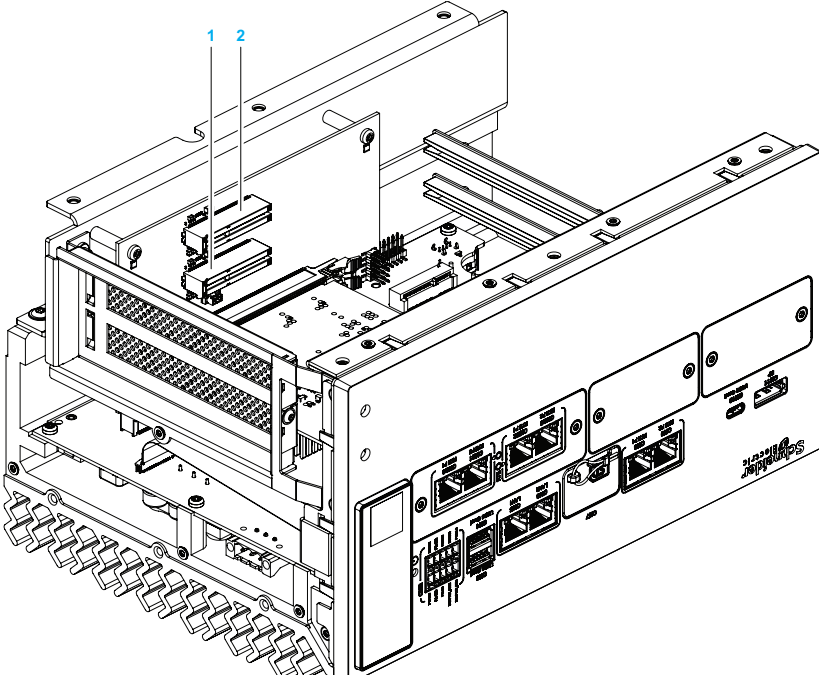
Step	Action
6	<p>At the top of the controller, remove the screws (1), (2), (3) and (4).</p> 
7	<p>Lift the U-shaped cover off of the controller housing. You can now access the PCI Express Card lower slot (1) and upper slot (2).</p> 

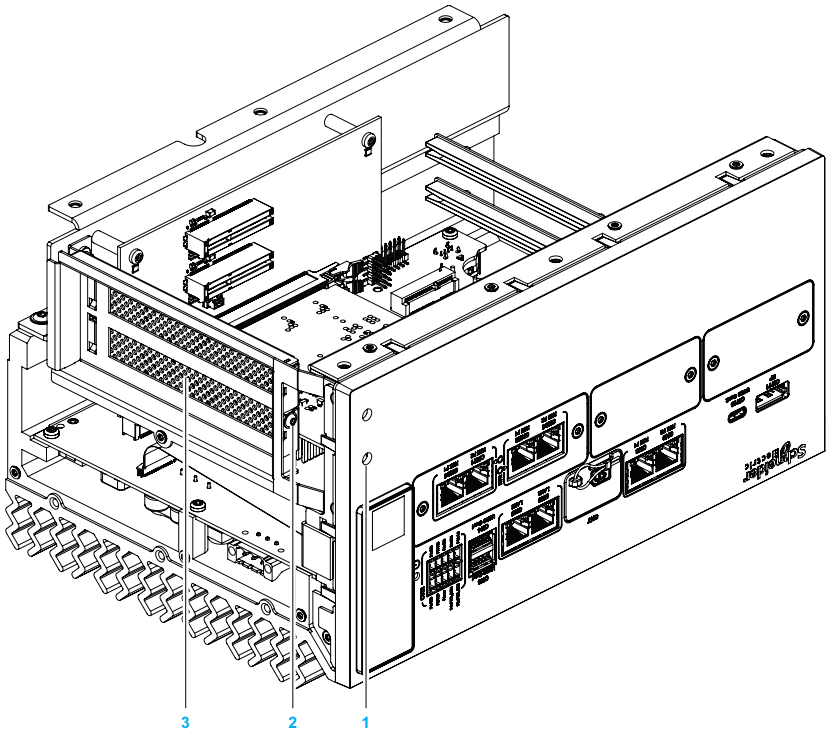
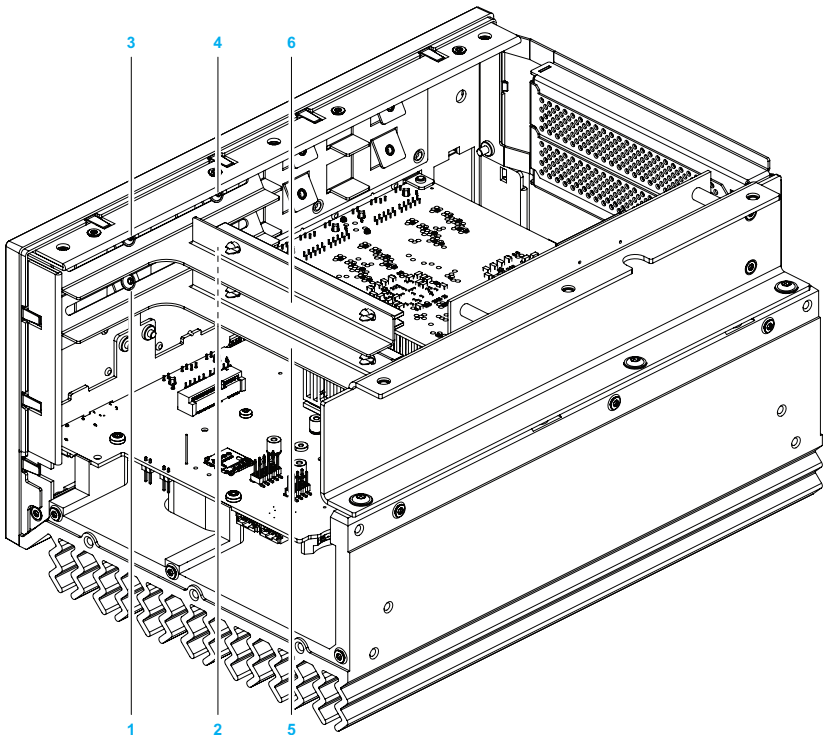
Step	Action
8	<p data-bbox="639 174 1337 248">Insert a screwdriver (TX10) through the hole (1) and remove the screw (2). Remove the blind plate (3).</p> 
9	<p data-bbox="639 1012 1458 1066">Loosen the screws (1), (2), (3) and (4) and slide the PCI Express Card supports (5) and (6) to the left.</p> 

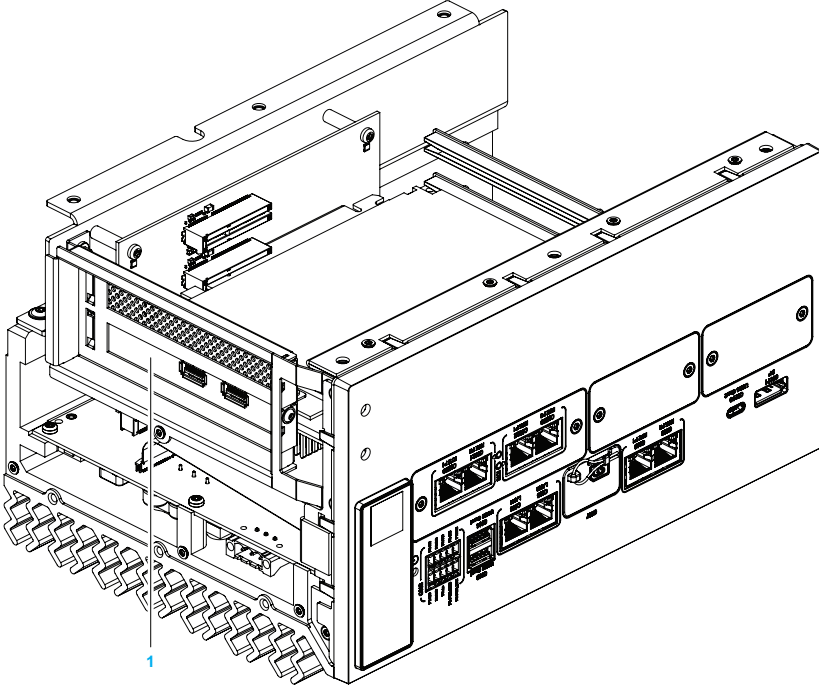
Step	Action
10	Insert the PCI Express Card (1) into the lower slot. 
11	Refit the screw (2) with a screwdriver (TX10) through the hole (1) shown in step 8, page 87 and tighten it with a tightening torque of 0.82 Nm (7.26 lb.in).
12	Slide the support (5) to the right until it holds the PCI Express card and re-tighten the screws (1) and (2) loosened in step 9, page 87 with a tightening torque of 0.82 Nm (7.26 lb.in).  Re-tighten the screws (3) and (4) for the support (6) loosened in step 9, page 87 with a tightening torque of 0.82 Nm (7.26 lb.in).
13	Refit the U-shaped cover of the controller housing removed in step 7, page 86.
14	Refit the screws removed in step 6, page 86. Tightening torques: <ul style="list-style-type: none"> <li>• Screws 1, 3, 4: 0.82 Nm (7.26 lb.in)</li> <li>• Screw 2: 0.43 Nm (0.38 lb.in)</li> </ul>
15	Refit the screws 1, 2 and 3 removed in removed in step 5, page 85 (tightening torque 0.82 Nm (7.26 lb.in)).
16	Refit the screws 1, 2, 3 and 4 removed in step 4, page 85 (tightening torque 0.82 Nm (7.26 lb.in)).
17	Refit the screws 2, 3, and 4 removed in step 3, page 84 (tightening torque 0.82 Nm (7.26 lb.in)).
18	Refit the grounding screw 1 also removed in step 3, page 84. For further details, refer to Grounding Procedure, page 56.
19	Refit the mounting plate removed in step 2, page 84. For further details, refer to Preparing the Controller for Mounting, page 51.
20	Refit the fan kit removed in step 1, page 84. For further details, refer to Uninstalling and Reinstalling a Fan Kit, page 69.

After having installed the PCI Express Card, install and commission the controller. For details, refer to Installation, page 47 and Commissioning, page 89.

The firmware of the controller automatically detects that a new PCI Express Card has been installed.

# Commissioning

## Commissioning

### General Information

Commissioning is the process of putting a machine/process into operation for production purposes. It includes, among other things, verifying the mechanical mounting and electrical installation, the hardware and software configuration and the application, and verifying the correct operation of the entire system with the connected equipment. This includes comprehensive tests for the different operating states, the defined safe state, and the potential error conditions. Such tests must be performed and the results be documented and/or certified according to your risk assessment as well as the regulations, standards, and process definitions that are applicable to your machine/process.

Commissioning is an iterative process. After you have mounted and installed the controller, you are ready for the first iteration of the commissioning procedure which consists of applying and removing power for the first time.

The following sections describe the parts of the commissioning procedure to the extent they are immediately related to the controller hardware after mechanical mounting and electrical installation. Refer to the appropriate user guides for information on additional commissioning steps related your configuration, application and additional equipment used in your machine/process.

### Initial Commissioning Steps

#### **DANGER**

##### **HAZARD OF ELECTRIC SHOCK, EXPLOSION OR ARC FLASH**

- Disconnect all power from all equipment including connected devices prior to removing any covers or doors, or installing or removing any accessories, hardware, cables, or wires except under the specific conditions specified in the appropriate hardware guide for this equipment.
- Always use a properly rated voltage sensing device to confirm the power is off where and when indicated.
- Replace and secure all covers, accessories, hardware, cables, and wires and confirm that a proper ground connection exists before applying power to the equipment.
- Use only the specified voltage when operating this equipment and any associated products.

**Failure to follow these instructions will result in death or serious injury.**

**▲ WARNING****UNINTENDED EQUIPMENT OPERATION**

- Commission or recommission the machine/process in which the controller is used before it is operated for the first time and after each modification whatsoever.
- Commission or recommission the machine/process in which the controller is used pursuant to all regulations, standards, and process definitions applicable to your machine/process.
- Only start the machine/process if there are no persons or obstructions in the zone of operation.
- Verify correct operation and effectiveness of all functions by performing comprehensive tests for all operating states, the defined safe state, and all potential error situations.
- Document all modifications and the results of the commissioning procedure in compliance with all regulations, standards, and process definitions applicable to your machine/process.

**Failure to follow these instructions can result in death, serious injury, or equipment damage.**

**▲ CAUTION****HOT SURFACES**

- Avoid unprotected contact with hot surfaces.
- Verify that the heat sink has cooled down before performing work on the controller.

**Failure to follow these instructions can result in injury or equipment damage.**

Procedure:

Step	Action
1	Verify correct mechanical installation, page 47 and electrical installation, page 55 of the controller.
2	Verify that all conditions specified in the present Hardware Guide, such as, but not limited to, ambient and electrical requirements, are met.
3	Verify that no equipment is connected to the inputs and the output (CN2).
4	Apply power to the controller.
5	Observe the LEDs, page 96 of the controller.
6	Disconnect the controller from power.
7	Document the results in accordance with the regulations, standards, and process definitions that are applicable to your machine/process

**NOTE:** Refer to the appropriate user guides for information on connecting to the controller from a PC and, if applicable, on starting the operating system of the industrial PC for the first time.

If you decide to connect to the controller during initial commissioning, ensure to include the following in the first steps:

- Verify that the settings for the real-time clock of the controller are correct.
- Verify that the settings for the buffer battery are correct.
- Enable fan monitoring.

Refer to the Modicon M660 Motion Controller Programming Guide, page 9 for details.

# Operation

## Introduction

The following sections describe the operation of the controller, to the extent it is immediately related to the controller hardware, after mechanical mounting, electrical installation and commissioning. Refer to the appropriate user guides for information on additional aspects related to the operation of your configuration, application and additional equipment used in your machine/process.

The following topics are covered:

- Powering on/off and setting the controller to standby using either the button or the input
- Hardware diagnostics via LEDs
- Watchdog and status output

# Powering On/Powering Off/Setting to Standby

<b>⚠ WARNING</b>
<b>UNINTENDED EQUIPMENT OPERATION</b>
Verify that your machine/process is in a defined safe state before changing the power state of the controller.
<b>Failure to follow these instructions can result in death, serious injury, or equipment damage.</b>

## Introduction

You can power the controller on and off or set it to standby using either the power button on the front face of the controller or the inputs **P4: PWR\_REM** and **P5: PWR\_RTN** of connector CN2:

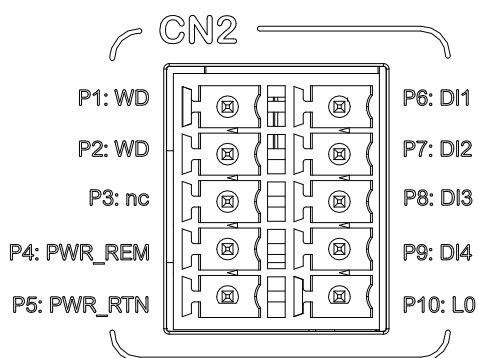

## Power States and Power State Transitions

The following figure presents the power states and power state transitions of the controller:

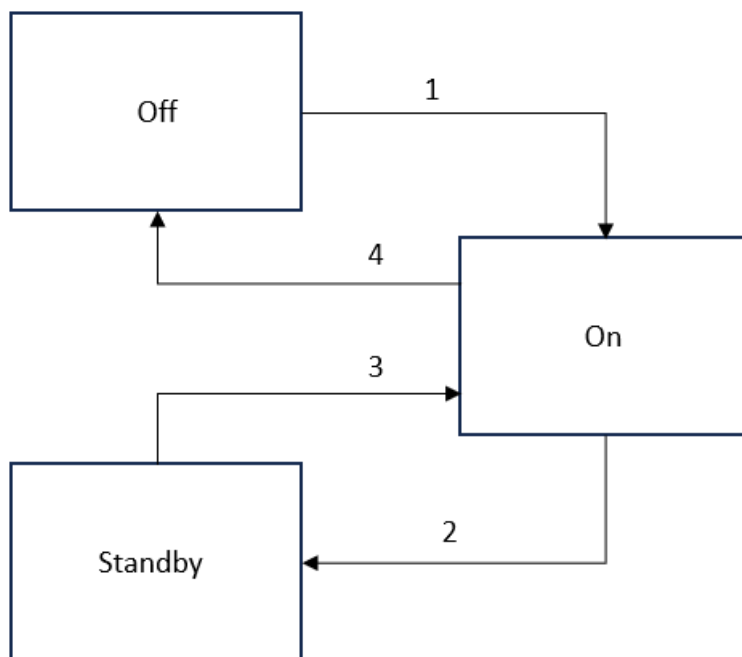

Power states of the controller:

Power State	Description
Off	This is the de-energized state of the controller. In this state, the controller still draws an input power of approximately up to 0.3 W.
On	This is the energized state of the controller.
Standby	This is the standby state of the controller. In this state, the RAM context for the operating system of the industrial PC (MN660P only) is maintained. Windows is in sleep mode. VxWorks (motion control) is disabled.

Power state transitions of the controller:

Power state transition	Description
1	<p><b>Off to On</b></p> <p>Using the button:</p> <ul style="list-style-type: none"> <li>Press for less than two seconds.</li> </ul> <p>Using the input:</p> <ul style="list-style-type: none"> <li>Set to HIGH and back to LOW within less than two seconds.</li> </ul> <p>The controller restarts.</p> <p><b>NOTE:</b> If you have powered off, page 92 the controller (power state transition 4), wait for at least three seconds before powering it on again. The controller does not boot if less than three seconds pass between the last power off (power state transition 4) and the next power on (power state transition 1).</p>
2	<p><b>On to Standby</b></p> <p>Using the button:</p> <ul style="list-style-type: none"> <li>Press for less than two seconds.</li> </ul> <p>Using the input:</p> <ul style="list-style-type: none"> <li>Set to HIGH and back to LOW within less than two seconds.</li> </ul> <p>The controller is set to the power state Standby. The RAM is maintained. VxWorks (motion control) is disabled. Windows (MN660P only) goes to sleep mode.</p>
3	<p><b>Standby to On</b></p> <p>Using the button:</p> <ul style="list-style-type: none"> <li>Press for less than two seconds.</li> </ul> <p>Using the input:</p> <ul style="list-style-type: none"> <li>Set to HIGH and back to LOW within less than two seconds.</li> </ul> <p>The industrial PC (MN660P only) restores Windows from the last power on state without going through the restart routine.</p>
4	<p><b>On to Off</b></p> <p>Using the button:</p> <ul style="list-style-type: none"> <li>Press for longer than three seconds.</li> </ul> <p>Using the input:</p> <ul style="list-style-type: none"> <li>Set to HIGH for longer than three seconds and then back to LOW.</li> </ul> <p>The controller stops.</p>

## Boot Sequence

M660 controllers scan the hardware for a bootable medium in the following default order:

1. SD card
2. USB drive(s)
3. Solid State Disk (SSD, hard drive)

### SD card

If an SD card is found (MN660C), the controller starts the hypervisor and boots VxWorks for motion control from the SD card. VxWorks can only be booted from the SD card.

---

The controller then searches for a bootable operating system for the industrial PC on the USB drives and the SSD.

### **USB drives**

If no SD card is found or if it does not contain a bootable operating system, the controller searches the USB drives for a bootable operating system for the industrial PC in this order:

1. USB 3.2 Gen 1 Type-A
2. USB 3.2 Gen 2 Type-C

**NOTE:** It is not possible to boot from the internal USB 2.0 Type-A.

### **SSD**

If no SD card and no USB drive are found or if these storage media do not contain a bootable operating system, the controller (MN660P only) searches the SSDs for a bootable operating system for the industrial PC.

You can modify the boot sequence via the BIOS.

**NOTE:** The SD card is referred to as USB port 7 in the BIOS.

**NOTE:** Verify that the boot medium is not write-protected. Do not remove the boot medium during operation of the controller.

## Motion System Watchdog and Status Output

### ▲ WARNING

#### INSUFFICIENT AND/OR INEFFECTIVE SAFETY-RELATED FUNCTIONS

- In your risk assessment, verify that the controller meets all requirements regarding the safety-related requirements and capabilities applicable to your machine/process.
- Verify that your risk assessment takes into account all potential consequences that can arise from the controller becoming inoperative.
- Do not use the inputs or the output to implement functions related to functional safety (for example, as per ISO 13849), or as a safety-related function (for example, as per IEC 61800-5-2).
- Use only equipment expressly intended and certified for safety-related purposes to implement safety-related functions.
- During the design as well as during commissioning or recommissioning of the machine/process, verify the correct operation and effectiveness of all safety-related functions and non-safety-related functions by performing comprehensive tests for all operating states, for the defined safe state of your machine/process, and for all potential error situations.
- Verify that your overall machine/process in which the controller is used is properly certified and/or approved according to all standards, regulations, and directives applicable at the installation site of the machine/process.

**Failure to follow these instructions can result in death, serious injury, or equipment damage.**

The tasks of the motion system watchdog of the controller include, among other things, monitoring of the real-time process (cycle time) and of the memory allocation. Potential root causes of errors detected by the motion system watchdog include operations in the motion system that cannot be completed within the cycle time.

**NOTE:** The motion system watchdog is not the application watchdog.

If an error is detected by the motion system watchdog, the following error response is initiated:

- The **ERR/WD** LED, page 97 lights solid red.
- The status output **WD** relay contact opens.
- The CPU is stopped.
- The Sercos core is reset. Subordinated Sercos devices do not receive data and stop operation after two Sercos cycles. Such subordinated devices trigger their own error response as defined by the application.
- The event “watchdog triggered” is saved to the message logger (available after reboot of the controller).

The response of the motion system watchdog to a detected error is neither a function related to functional safety (for example, as per ISO 13849) nor a safety function (for example, as per IEC 61800-5-2). You can, for example, connect the status output **WD** to the Enable input of a drive or use it to remove power from a drive. However, you must ensure that your machine/process transitions to a safe state as defined in your risk assessment using dedicated equipment expressly intended and certified for safety-related purposes such as, but not limited to, safety controllers and mechanical brakes.

If the motion system watchdog has detected an error, restart the controller. If the error persists, verify your application. If the error still persists, contact your local Schneider Electric service representative.

# Hardware Diagnostics

## Overview

M660 controllers provide an LED panel with 10 LEDs:

- **PWR**
- **SD/HD**
- **USR**
- **DI1 ... DI4**
- **ERR/WD**
- **RTE** (for the dual port CN8/CN9)
- **SSC**

In addition, the RJ45 sockets for LAN and RTE are equipped with two LEDs each for indicating connection state and data traffic.

The dual port RTE sockets CN20/CN21 and CN22/CN23 are equipped with separate **RTE** LEDs.

## Hardware Diagnostics through the PWR LED

The **PWR** LED provides information on the state of the power supply to the controller.

State	Description
Off	Controller off
Flashing green	Controller in standby
Solid green	Controller on (operation)
Solid red	Hardware error detected

## Hardware Diagnostics through the SD/HD LED

The **SD/HD** LED provides information on the access state of the SSD drive or SD card.

State	Description
Off	No access to SSD drive or SD card
Flashing yellow	Access to SSD drive or SD card

## Hardware Diagnostics through the USR LED

You can configure the **USR** LED to your requirements via EcoStruxure Automation Expert - Motion. It provides the colors green and red and the states off, flashing and solid on. Refer to the Modicon M660 Motion Controller Programming Guide, page 9 for details.

## Hardware Diagnostics through the DI1, DI2, DI3, DI4 LEDs

The LEDs **DI1**, **DI2**, **DI3** and **DI4** provide information on the states of the digital inputs.

State	Description
Off	The corresponding digital input is not activated.
Solid green	The corresponding digital input is activated.

## Hardware Diagnostics through the ERR/WD LED

The **ERR/WD** LED provides information on detected errors.

State	Description
Off	Either no power or controller is starting.
Solid green	No error detected.
Flashing red	Error detected.  The error was detected at the automation system level (for example, application, motion bus, connected devices). It is not an error detected by the watchdog of the controller. Refer to the Modicon M660 Motion Controller Programming Guide, page 9 for details on remedying the condition.
Solid red	If the LED is solid red, an error has been detected by the watchdog. If this type of error is detected, the status relay output opens.  Restart the controller. If the error persists, verify your application. If the error still persist, contact your local Schneider Electric service representative.

Refer to Watchdog and Status Output, page 95 for additional information.

## Hardware Diagnostics through the RTE LED

The **RTE** LED provides information on the state of the real-time Ethernet communication of the RTE ports CN8 and CN9.

State	Description
Off	No Sercos communication
Orange	The controller is in a Sercos communication phase between CP0 and CP3.
Green	The controller is in Sercos communication phase CP4.
Red	A communication error has been detected.

**NOTE:** The **RTE** LED on the LED panel relates to the dual RTE ports CN8 and CN9. Additional dual RTE ports for CN20/CN21 and CN22/CN23 are equipped with separate **RTE** LEDs.

## Hardware Diagnostics through the SSC LED

Reserved. The LED has no function regardless of its state.

## Hardware Diagnostics through the LEDs at LAN and RTE RJ45 Sockets

The LEDs at LAN and RTE RJ45 sockets provide information on the network communication state and transmission speeds.

LEDs at LAN sockets:

<b>State</b>	<b>Description</b>
LED 1 off	Transmission speed 10 MB or 100 MB
LED 1 solid yellow	Transmission speed 1 GB
LED 1 solid green	Transmission speed 2.5 GB
LED 2 off	No link
LED 2 solid green	Link established, no activity
LED 2 flashing green	Activity

LEDs at RTE sockets:

<b>State</b>	<b>Description</b>
LED 1 off	Reserved (always off)
LED 2 off	No link
LED 2 solid green	Link established, no activity
LED 2 flashing green	Activity

# Maintenance

## Maintenance

### Overview

The equipment may only be repaired by a Schneider Electric customer service center.

For all service matters, contact your local Schneider Electric service representative.

#### **▲ WARNING**

##### **UNINTENDED EQUIPMENT OPERATION**

- Do not attempt to repair this equipment outside of authorized Schneider Electric service centers.
- Do not perform any work whatsoever, including, but not limited to installation, service, or maintenance on this equipment unless such work is described in the present document.
- Update your application program every time you change the physical hardware configuration.

**Failure to follow these instructions can result in death, serious injury, or equipment damage.**

## Maintenance Activities

Create a maintenance plan for your machine/process that includes the following maintenance activities for the controller, to be performed at regular intervals:

- Inspect the wiring and the connections.
- Tighten the threaded connections.
- Clean dust and dirt off the controller.
- Verify that all requirements with regard to the ambient conditions are met at all times.
- If you have installed a battery, verify its condition. Replace the battery, if necessary. Refer to *Installation of a Buffer Battery*, page 70 for details.

As a machine designer or system integrator, include this information in the maintenance plan for your customer.



# Index

## A

accessories .....	23
ambient temperature .....	28

## B

battery .....	70
boot sequence .....	93
bottom view .....	14
buffer battery .....	70

## C

cleaning .....	99
clearances .....	48
CodeMeter .....	73
commissioning .....	89
control cabinet .....	47

## D

degree of protection .....	47
diagnostics .....	96
digital inputs .....	37, 61
dimensions .....	30
DIn LED .....	96
DisplayPort .....	45

## E

electrical installation .....	55
electromagnetic compatibility .....	35, 55
EMC .....	35
enclosure .....	47
environmental data .....	26
ERR/WD LED .....	96
Ethernet ports .....	40

## F

fan kit .....	68
front view .....	14

## G

general data .....	24
grounding .....	56

## H

hardware diagnostics .....	96
----------------------------	----

## I

inductive loads .....	63
input for controlling power on/off/standby .....	66
input for controlling power on/power off/standby .....	38
inspection .....	99
installation .....	
buffer battery .....	70

digital inputs .....	61
electromagnetic compatibility .....	55
fan kit .....	68
grounding .....	56
input for controlling power on/off/standby .....	66
PCI Express Card .....	83
PCI Express Mini Card module .....	75
power supply .....	58
security key .....	73
status output .....	63
intended use .....	6
interfaces overview .....	14
introduction .....	13
IP rating .....	47

## L

LAN ports .....	40
LEDs .....	96

## M

maintenance .....	99
mechanical data .....	30
mechanical installation .....	47
motion system watchdog .....	95
mounting .....	51
mounting preparation .....	51
mounting prerequisites and requirements .....	47
mounting procedure .....	52
mounting type .....	51

## O

operating systems .....	24
operation .....	91
boot sequence .....	93
diagnostics via LEDs .....	96
powering on/off .....	92
standby .....	92
status output .....	95
watchdog .....	95
overview .....	14

## P

PCI Express Card .....	83
PCI Express Card slots .....	43
PCI Express Mini Card module .....	75
PCI Express Mini Card slots .....	44
pollution degree .....	47
power states/transitions .....	92
power supply .....	36, 58
powering on/off .....	92
processor .....	24
PWR LED .....	96

## Q

qualification of personnel .....	5
----------------------------------	---

## R

RAM .....	24
real-time clock .....	70, 89
RTC .....	70, 89

---

RTE ports .....	40
-----------------	----

## S

SD card slot .....	46
SD/HD LED .....	96
security key .....	73
spare parts .....	23
SSC LED .....	96
standby .....	92
status output .....	39, 63, 95
storage .....	26
system overview .....	13

## T

technical data .....	24
ambient temperature .....	28
digital inputs .....	37
dimensions .....	30
DisplayPort .....	45
electromagnetic compatibility .....	35
environmental data .....	26
Ethernet ports .....	40
input for controlling power on/power off/standby ...	38
LAN ports .....	40
mechanical data .....	30
operating systems .....	24
PCI Express Card slots .....	43
PCI Express Mini Card slots .....	44
power supply .....	36
processor .....	24
RAM .....	24
RTE ports .....	40
SD card slot .....	46
status output .....	39
storage .....	26
technical data .....	24
transportation .....	27
USB ports .....	42
weight .....	30
top view .....	14
transportation .....	27
type code .....	21

## U

USB ports .....	42
USR LED .....	96

## W

watchdog .....	95
weight .....	30



Schneider Electric  
35 rue Joseph Monier  
92500 Rueil Malmaison  
France

[www.se.com](http://www.se.com)

As standards, specifications, and design change from time to time, please ask for confirmation of the information given in this publication.

© 2025 Schneider Electric. All rights reserved.

EIO0000005519.01