

Modicon Edge I/O NTS

Field Device Master Modules

User Guide

Original instructions

EIO0000005270.02
01/2026

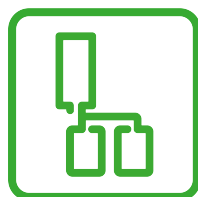

Legal Information

The information provided in this document contains general descriptions, technical characteristics and/or recommendations related to products/solutions.

This document is not intended as a substitute for a detailed study or operational and site-specific development or schematic plan. It is not to be used for determining suitability or reliability of the products/solutions for specific user applications. It is the duty of any such user to perform or have any professional expert of its choice (integrator, specifier or the like) perform the appropriate and comprehensive risk analysis, evaluation and testing of the products/solutions with respect to the relevant specific application or use thereof.

The Schneider Electric brand and any trademarks of Schneider Electric SE and its subsidiaries referred to in this document are the property of Schneider Electric SE or its subsidiaries. All other brands may be trademarks of their respective owner.

This document and its content are protected under applicable copyright laws and provided for informative use only. No part of this document may be reproduced or transmitted in any form or by any means (electronic, mechanical, photocopying, recording, or otherwise), for any purpose, without the prior written permission of Schneider Electric.

Schneider Electric does not grant any right or license for commercial use of the document or its content, except for a non-exclusive and personal license to consult it on an "as is" basis.

Schneider Electric reserves the right to make changes or updates with respect to or in the content of this document or the format thereof, at any time without notice.

To the extent permitted by applicable law, no responsibility or liability is assumed by Schneider Electric and its subsidiaries for any errors or omissions in the informational content of this document, as well as any non-intended use or misuse of the content thereof.

Table of Contents

Safety Information	5
Before You Begin	5
Start-up and Test	6
Operation and Adjustments	7
About the Document	8
IO-Link Field Device Master Module	13
NTSFIO0400 Field Device Master Module, IO-Link Master, 4	
Channels	14
NTSFIO0400 Presentation	14
Overview	14
Main Characteristics	14
Purchasing Information	15
Physical Description	16
Status LEDs	17
NTSFIO0400 Characteristics	18
Overview	18
Dimensions	19
Weight	19
General Characteristics	19
Characteristics of L+ Supply	20
Characteristics of the C/Q Signal in IO-Link Master Mode	20
Characteristics of C/Q Signal in Discrete Input Mode and DI	
Signal	20
Characteristics of the C/Q Signal in Discrete Output Mode	21
NTSFIO0400 Wiring	21
Overview	21
Wiring Rules	21
Wiring Diagrams	21
NTSFIO0400 Parameters	23
Overview	23
IO-Link Device IODD Import and Selection	24
Parameters Description	27
IO-Link Field Device Master Module Appendices	33
EventQualifier Description	33
Port Mode, Validation and Backup Parameters Description	34
Master Cycle Time Description	34
Serial Line Field Device Master Module	35
NTSFMB0120/NTSFMB0120H Field Device Master Module, Serial,	
Modbus RTU, ASCII, Client, 115 Kbps, Standard/Hardened	36
NTSFMB0120/NTSFMB0120H Presentation	36
Overview	36
Main Characteristics	36
Purchasing Information	37
Physical Description	38
Status LEDs	39
NTSFMB0120/NTSFMB0120H Characteristics	40
Overview	40
Dimensions	40

Weight.....	40
General Characteristics	41
Serial Line Characteristics	41
NTSFMB0120/NTSFMB0120H Wiring.....	41
Overview	41
Wiring Rules	41
Wiring Diagrams	42
NTSFMB0120/NTSFMB0120H Parameters	45
Overview	45
Generic Fieldbus Device	45
Parameters Description	48
Serial Line Field Device Master Module Appendices.....	54
Modbus Scanner Operating Mode	54
Diagnostic Data	55
Index	56

Safety Information

Important Information

Read these instructions carefully, and look at the equipment to become familiar with the device before trying to install, operate, service, or maintain it. The following special messages may appear throughout this documentation or on the equipment to warn of potential hazards or to call attention to information that clarifies or simplifies a procedure.



The addition of this symbol to a "Danger" or "Warning" safety label indicates that an electrical hazard exists which will result in personal injury if the instructions are not followed.



This is the safety alert symbol. It is used to alert you to potential personal injury hazards. Obey all safety messages that follow this symbol to avoid possible injury or death.

⚠ DANGER
DANGER indicates a hazardous situation which, if not avoided, will result in death or serious injury.

⚠ WARNING
WARNING indicates a hazardous situation which, if not avoided, could result in death or serious injury.

⚠ CAUTION
CAUTION indicates a hazardous situation which, if not avoided, could result in minor or moderate injury.

NOTICE
NOTICE is used to address practices not related to physical injury.

Please Note

Electrical equipment should be installed, operated, serviced, and maintained only by qualified personnel. No responsibility is assumed by Schneider Electric for any consequences arising out of the use of this material.

A qualified person is one who has skills and knowledge related to the construction and operation of electrical equipment and its installation, and has received safety training to recognize and avoid the hazards involved.

Before You Begin

Do not use this product on machinery lacking effective point-of-operation guarding. Lack of effective point-of-operation guarding on a machine can result in serious injury to the operator of that machine.

⚠ WARNING

UNGUARDED EQUIPMENT

- Do not use this software and related automation equipment on equipment which does not have point-of-operation protection.
- Do not reach into machinery during operation.

Failure to follow these instructions can result in death, serious injury, or equipment damage.

This automation equipment and related software is used to control a variety of industrial processes. The type or model of automation equipment suitable for each application will vary depending on factors such as the control function required, degree of protection required, production methods, unusual conditions, government regulations, etc. In some applications, more than one processor may be required, as when backup redundancy is needed.

Only you, the user, machine builder or system integrator can be aware of all the conditions and factors present during setup, operation, and maintenance of the machine and, therefore, can determine the automation equipment and the related safeties and interlocks which can be properly used. When selecting automation and control equipment and related software for a particular application, you should refer to the applicable local and national standards and regulations. The National Safety Council's Accident Prevention Manual (nationally recognized in the United States of America) also provides much useful information.

In some applications, such as packaging machinery, additional operator protection such as point-of-operation guarding must be provided. This is necessary if the operator's hands and other parts of the body are free to enter the pinch points or other hazardous areas and serious injury can occur. Software products alone cannot protect an operator from injury. For this reason the software cannot be substituted for or take the place of point-of-operation protection.

Ensure that appropriate safeties and mechanical/electrical interlocks related to point-of-operation protection have been installed and are operational before placing the equipment into service. All interlocks and safeties related to point-of-operation protection must be coordinated with the related automation equipment and software programming.

NOTE: Coordination of safeties and mechanical/electrical interlocks for point-of-operation protection is outside the scope of the Function Block Library, System User Guide, or other implementation referenced in this documentation.

Start-up and Test

Before using electrical control and automation equipment for regular operation after installation, the system should be given a start-up test by qualified personnel to verify correct operation of the equipment. It is important that arrangements for such a check are made and that enough time is allowed to perform complete and satisfactory testing.

⚠ WARNING

EQUIPMENT OPERATION HAZARD

- Verify that all installation and set up procedures have been completed.
- Before operational tests are performed, remove all blocks or other temporary holding means used for shipment from all component devices.
- Remove tools, meters, and debris from equipment.

Failure to follow these instructions can result in death, serious injury, or equipment damage.

Follow all start-up tests recommended in the equipment documentation. Store all equipment documentation for future references.

Software testing must be done in both simulated and real environments.

Verify that the completed system is free from all short circuits and temporary grounds that are not installed according to local regulations (according to the National Electrical Code in the U.S.A, for instance). If high-potential voltage testing is necessary, follow recommendations in equipment documentation to prevent accidental equipment damage.

Before energizing equipment:

- Remove tools, meters, and debris from equipment.
- Close the equipment enclosure door.
- Remove all temporary grounds from incoming power lines.
- Perform all start-up tests recommended by the manufacturer.

Operation and Adjustments

The following precautions are from the NEMA Standards Publication ICS 7.1-1995:

(In case of divergence or contradiction between any translation and the English original, the original text in the English language will prevail.)

- Regardless of the care exercised in the design and manufacture of equipment or in the selection and ratings of components, there are hazards that can be encountered if such equipment is improperly operated.
- It is sometimes possible to misadjust the equipment and thus produce unsatisfactory or unsafe operation. Always use the manufacturer's instructions as a guide for functional adjustments. Personnel who have access to these adjustments should be familiar with the equipment manufacturer's instructions and the machinery used with the electrical equipment.
- Only those operational adjustments required by the operator should be accessible to the operator. Access to other controls should be restricted to prevent unauthorized changes in operating characteristics.

About the Document

Document Scope

This guide describes the implementation of Modicon Edge I/O NTS Field Device Master modules. It provides the description, characteristics, wiring diagrams and configuration details for Modicon Edge I/O NTS Field Device Master modules.

Validity Note

This document has been updated for the release of Modicon Edge I/O NTS Field Device Master modules firmware versions available at the publication date of this document.

This document has been updated for the release of the Modicon Edge I/O Configurator V1.0.1.

The characteristics of the products described in this document are intended to match the characteristics that are available on www.se.com. As part of our corporate strategy for constant improvement, we may revise the content over time to enhance clarity and accuracy. If you see a difference between the characteristics in this document and the characteristics on www.se.com, consider www.se.com to contain the latest information.

Product Related Information

DANGER

HAZARD OF ELECTRIC SHOCK, EXPLOSION OR ARC FLASH

- Disconnect all power from all equipment including connected devices prior to removing any covers or doors, or installing or removing any accessories, hardware, cables, or wires except under the specific conditions specified in the appropriate hardware guide for this equipment.
- Always use a properly rated voltage sensing device to confirm the power is off where and when indicated.
- Replace and secure all covers, accessories, hardware, cables, and wires and confirm that a proper ground connection exists before applying power to the equipment.
- Use only the specified voltage when operating this equipment and any associated products.

Failure to follow these instructions will result in death or serious injury.

▲ WARNING**LOSS OF CONTROL**

- Perform a Failure Mode and Effects Analysis (FMEA), or equivalent risk analysis, of your application, and apply preventive and detective controls before implementation.
- Provide a fallback state for undesired control events or sequences.
- Provide separate or redundant control paths wherever required.
- Supply appropriate parameters, particularly for limits.
- Review the implications of transmission delays and take actions to mitigate them.
- Review the implications of communication link interruptions and take actions to mitigate them.
- Provide independent paths for control functions (for example, emergency stop, over-limit conditions, and error conditions) according to your risk assessment, and applicable codes and regulations.
- Apply local accident prevention and safety regulations and guidelines.¹
- Test each implementation of a system for proper operation before placing it into service.

Failure to follow these instructions can result in death, serious injury, or equipment damage.

¹ For additional information, refer to NEMA ICS 1.1 (latest edition), *Safety Guidelines for the Application, Installation, and Maintenance of Solid State Control* and to NEMA ICS 7.1 (latest edition), *Safety Standards for Construction and Guide for Selection, Installation and Operation of Adjustable-Speed Drive Systems* or their equivalent governing your particular location.

▲ WARNING**UNINTENDED EQUIPMENT OPERATION**

- Only use software approved by Schneider Electric for use with this equipment.
- Update your application program every time you change the physical hardware configuration.

Failure to follow these instructions can result in death, serious injury, or equipment damage.

General Cybersecurity Information

In recent years, the growing number of networked machines and production plants has seen a corresponding increase in the potential for cyber threats, such as unauthorized access, data breaches, and operational disruptions. You must, therefore, consider all possible cybersecurity measures to help protect assets and systems against such threats.

To help keep your Schneider Electric products secure and protected, it is in your best interest to implement the cybersecurity best practices as described in the [Cybersecurity Best Practices](#) document.

Schneider Electric provides additional information and assistance:

- [Subscribe to the Schneider Electric security newsletter.](#)
- [Visit the Cybersecurity Support Portal web page to:](#)
 - [Find Security Notifications.](#)
 - [Report vulnerabilities and incidents.](#)
- [Visit the Schneider Electric Cybersecurity and Data Protection Posture web page to:](#)
 - [Access the cybersecurity posture.](#)
 - [Learn more about cybersecurity in the cybersecurity academy.](#)
 - [Explore the cybersecurity services from Schneider Electric.](#)

Environmental Data

For product compliance and environmental information, refer to the [Schneider Electric Environmental Data Program](#).

Available Languages of the Document

The document is available in these languages:

- [English \(EIO0000005270\)](#)
- [French \(EIO0000005271\)](#)
- [Chinese \(EIO0000005275\)](#)

Related Documents

Title of documentation	Reference number
Modicon Edge I/O - System Planning and Installation Guide	EIO0000004786 (ENG)
	EIO0000004787 (FRE)
	EIO0000004791 (CHS)
Modicon Edge I/O - Configurator and Web Interface - User Guide	EIO0000004810 (ENG)
	EIO0000004811 (FRE)
	EIO0000004815 (CHS)
Modicon Edge I/O - Software Integration and Compatibility - User Guide	EIO0000004818 (ENG)
	EIO0000004819 (FRE)
	EIO0000004823 (CHS)
Modicon Edge I/O - Diagnostic Data - User Guide	EIO0000004826 (ENG)
	EIO0000004827 (FRE)
	EIO0000004831 (CHS)
Modicon Edge I/O NTS - Network Interface Modules - User Guide	EIO0000004794 (ENG)
	EIO0000004795 (FRE)
	EIO0000004799 (CHS)
Modicon Edge I/O NTS - Discrete Modules - User Guide	EIO0000005238 (ENG)
	EIO0000005239 (FRE)
	EIO0000005243 (CHS)
Modicon Edge I/O NTS - Analog Modules - User Guide	EIO0000005246 (ENG)
	EIO0000005247 (FRE)
	EIO0000005251 (CHS)
Modicon Edge I/O NTS - Motion Expert Modules - User Guide	EIO0000005254 (ENG)
	EIO0000005255 (FRE)
	EIO0000005259 (CHS)
Modicon Edge I/O NTS - Counting Modules - User Guide	EIO0000005262 (ENG)
	EIO0000005263 (FRE)
	EIO0000005267 (CHS)

To find documents online, visit the Schneider Electric download center (www.se.com/ww/en/download/).

Information on Non-Inclusive or Insensitive Terminology

As a responsible, inclusive company, Schneider Electric is constantly updating its communications and products that contain non-inclusive or insensitive terminology. However, despite these efforts, our content may still contain terms that are deemed inappropriate by some customers.

Terminology Derived from Standards

The technical terms, terminology, symbols and the corresponding descriptions in the information contained herein, or that appear in or on the products themselves, are generally derived from the terms or definitions of international standards.

In the area of functional safety systems, drives and general automation, this may include, but is not limited to, terms such as *safety*, *safety function*, *safe state*, *fault*, *fault reset*, *malfunction*, *failure*, *error*, *error message*, *dangerous*, etc.

Among others, these standards include:

Standard	Description
IEC 61131-2:2007	Programmable controllers, part 2: Equipment requirements and tests.
ISO 13849-1:2023	Safety of machinery: Safety related parts of control systems. General principles for design.
EN 61496-1:2020	Safety of machinery: Electro-sensitive protective equipment. Part 1: General requirements and tests.
ISO 12100:2010	Safety of machinery - General principles for design - Risk assessment and risk reduction
EN 60204-1:2006	Safety of machinery - Electrical equipment of machines - Part 1: General requirements
ISO 14119:2013	Safety of machinery - Interlocking devices associated with guards - Principles for design and selection
ISO 13850:2015	Safety of machinery - Emergency stop - Principles for design
IEC 62061:2021	Safety of machinery - Functional safety of safety-related electrical, electronic, and electronic programmable control systems
IEC 61508-1:2010	Functional safety of electrical/electronic/programmable electronic safety-related systems: General requirements.
IEC 61508-2:2010	Functional safety of electrical/electronic/programmable electronic safety-related systems: Requirements for electrical/electronic/programmable electronic safety-related systems.
IEC 61508-3:2010	Functional safety of electrical/electronic/programmable electronic safety-related systems: Software requirements.
IEC 61784-3:2021	Industrial communication networks - Profiles - Part 3: Functional safety fieldbuses - General rules and profile definitions.
2006/42/EC	Machinery Directive
2014/30/EU	Electromagnetic Compatibility Directive
2014/35/EU	Low Voltage Directive

In addition, terms used in the present document may tangentially be used as they are derived from other standards such as:

Standard	Description
IEC 60034 series	Rotating electrical machines
IEC 61800 series	Adjustable speed electrical power drive systems
IEC 61158 series	Digital data communications for measurement and control – Fieldbus for use in industrial control systems

Finally, the term *zone of operation* may be used in conjunction with the description of specific hazards, and is defined as it is for a *hazard zone* or *danger zone* in the *Machinery Directive (2006/42/EC)* and *ISO 12100:2010*.

NOTE: The aforementioned standards may or may not apply to the specific products cited in the present documentation. For more information concerning the individual standards applicable to the products described herein, see the characteristics tables for those product references.

IO-Link Field Device Master Module

What's in This Part

NTSFIO0400 Field Device Master Module, IO-Link Master, 4 Channels.....	14
IO-Link Field Device Master Module Appendices	33

NTSFIO0400 Field Device Master Module, IO-Link Master, 4 Channels

What's in This Chapter

NTSFIO0400 Presentation	14
NTSFIO0400 Characteristics.....	18
NTSFIO0400 Wiring	21
NTSFIO0400 Parameters	23

NTSFIO0400 Presentation

Overview

This section provides a presentation of the NTSFIO0400 module.

Main Characteristics

The following table describes the main characteristics of the NTSFIO0400 module:

Main Characteristics	Value
Product or component type	IO-Link master module with 4 channels: <ul style="list-style-type: none"> Compliant with IO-Link standard V1.1 Without data consistency between channels
Number of channels	<ul style="list-style-type: none"> Up to 4 IO-Link devices (3 / 4 wire - Class A) <p>NOTE: IO-Link devices Class B (M12 connector) can be connected with an external power supply, see wiring diagram NTSFIO0400 Wiring diagram IO-Link Class B with external power supply, page 23</p> <ul style="list-style-type: none"> Up to 4 (C/Q) discrete channels (configurable as input or output) Up to 4 additional discrete input (DI) channels
Input and output rated voltage	24 Vdc
Input signal type	Sink
Input current	2.5 mA / input channel
Output signal type	Push-Pull
Output current	200 mA / channel for C/Q output
Operating mode	Asynchronous

Purchasing Information

The following figure presents the elements of the Modicon Edge I/O NTSFIO0400 module:

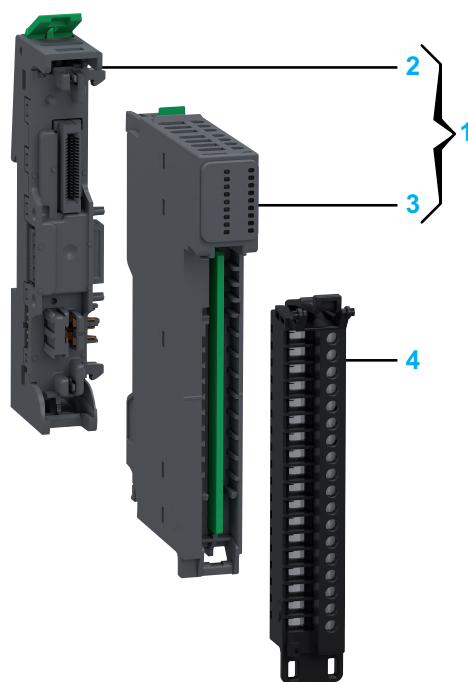

Number	Reference	Description
1	NTSFIO0400K	Base + Module (kit) NOTE: The module and its corresponding base can be purchased as a kit.
2	NTSXBA0100H	Spare Base, 1 Slot, for Input/Output Common or Expert Module, Hardened
3	NTSFIO0400	Field Device Master Module, IO-Link Master, 4 Channels
4	NTSXTB18200H NTSXTB18201H NTSXTB18000H NTSXTB18001H	Spring Terminal Block, 18 Points, 3.81 mm Pitch, Without Cover, use on Low Height Module, Hardened Spring Terminal Block, 18 Points, 3.81 mm Pitch, With Cover, use on Low Height Module, Hardened Screw Terminal Block, 18 Points, 3.81 mm Pitch, Without Cover, use on Low Height Module, Hardened Screw Terminal Block, 18 Points, 3.81 mm Pitch, With Cover, use on Low Height Module, Hardened NOTE: The terminal blocks are purchased separately.

NOTE: For more information on accessories and spare parts, refer to Modicon Edge I/O - System Planning and Installation Guide.

Physical Description

The following figure presents the elements of the module:

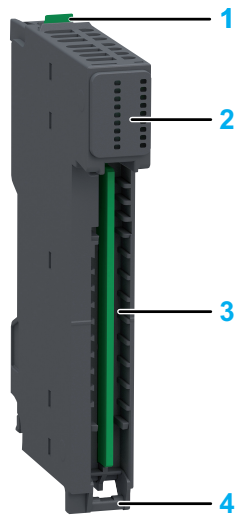

- 1: Release button for disengaging the module from the base
- 2: Status LEDs
- 3: Slot for the terminal block
- 4: Hinge for the terminal block installation

Status LEDs

The following figure presents the NTSFIO0400 status LEDs:

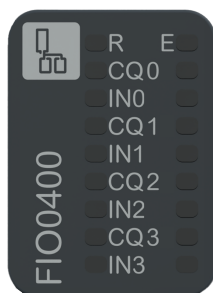

The following table describes the status of LEDs:

R (Green)	E (Red)	CQ0...3 (Green / Red / Yellow)	IN0...3 (Green)	Description
Initialization and non-operational states				
OFF	OFF	OFF	OFF	Indicates that the module is not energized.
OFF	Fast Flash	-	-	Indicates that the module has detected a system error.
Regular Flash	OFF	-	-	Indicates that the firmware is being updated.
Regular Flash	ON	-	-	Indicates that a module mismatch is detected.
Single Flash	OFF	-	-	Indicates that the module is energized and not configured.
Operational state				
ON	OFF	OFF	-	Indicates that the discrete input or output is deactivated. ⁽¹⁾
ON	OFF	Green ON	-	Indicates that the discrete input or output is activated. ⁽¹⁾
ON	OFF	Yellow ON	-	Indicates an active IO-Link communication. ⁽²⁾
ON	Regular Flash	-	-	Indicates that a channel-related error is detected or the module is in fallback state.
ON	Regular Flash	Red Regular Flash	-	Indicates that a configured IO-Link device is not connected. ⁽²⁾
ON	Regular Flash	Red ON	-	Indicates that a channel-related error is detected, for instance: ⁽²⁾ <ul style="list-style-type: none"> Indicates an undervoltage detection. Indicates an overload detection. Indicates an internal error detection. Indicates that the configured IO-Link device does not match the device connected.
ON	ON	-	-	Indicates that a module-related error is detected.
ON	-	-	OFF	Indicates that the discrete input is deactivated. ⁽³⁾
ON	-	-	ON	Indicates that the discrete input is activated. ⁽³⁾
<p>⁽¹⁾ Relevant if Port Mode and CQ behavior is set to SIO input Mode or SIO output Mode.</p> <p>⁽²⁾ Relevant if Port Mode and CQ behavior is set to Manual Mode or Autostart Mode.</p> <p>⁽³⁾ Relevant if IQ Behavior is set to Digital input.</p>				

NOTE: For an extended diagnostic, refer to the Modicon Edge I/O - Diagnostic Data - User Guide

The following graphic shows the system status of LEDs during module operation:

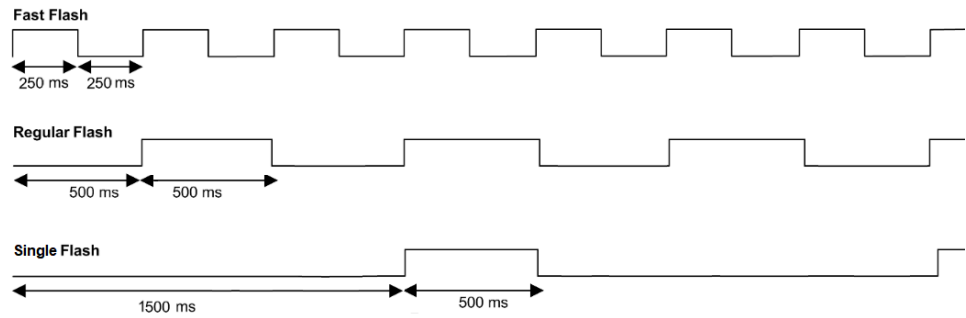

NTSFIO0400 Characteristics

Overview

This section provides a general description of the characteristics of the module.

⚠ WARNING

UNINTENDED EQUIPMENT OPERATION

Do not exceed any of the rated values specified in the environmental and electrical characteristics tables.

Failure to follow these instructions can result in death, serious injury, or equipment damage.

For more information on environmental characteristics, refer to Modicon Edge I/O - System Planning and Installation Guide.

Dimensions

The following figure presents the external dimensions of the assembled module:

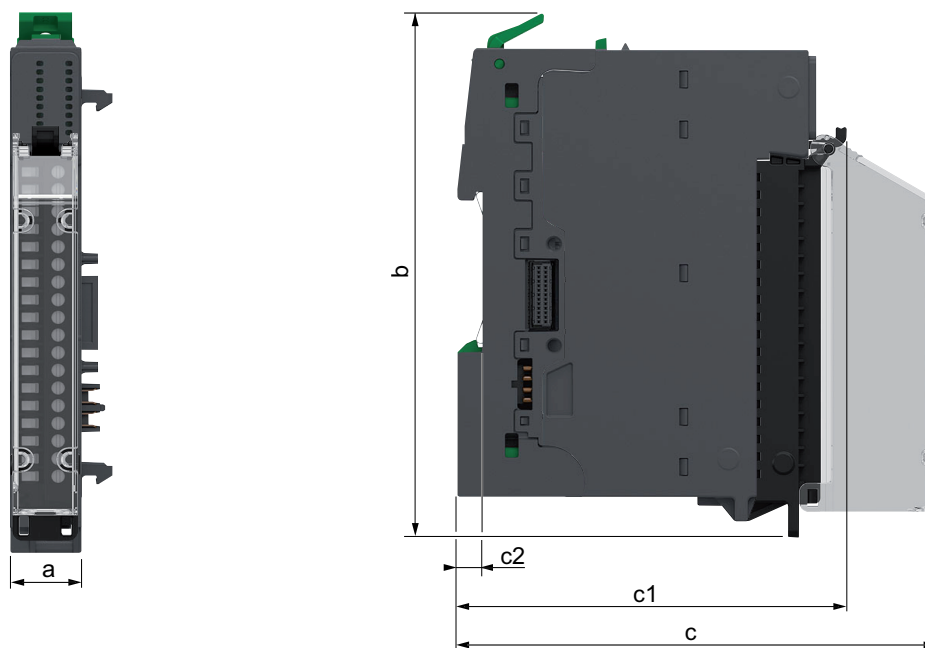

- a:** 15 mm (0.59 in)
- b:** 116.6 mm (4.57 in)
- c:** 107.5 mm (4.21 in)
- c1:** 88.2 mm (3.46 in)
- c2:** 5.6 mm (0.2 in)

Weight

- NTSFIO0400: 49 g (1.73 oz)
- NTSFIO0400K: 76 g (2.68 oz)

General Characteristics

The following table describes the general characteristics of the NTSFIO0400 module:

Characteristics	Value
Rated supplied voltage	24 Vdc
Power supply source	Connected to the 24 Vdc field power segment
Power supplied voltage range	20.4...28.8 Vdc
24 Vdc I/O segment current draw	1,709.6 mA
Power dissipation	1.40 W
Maximum cable length	20 m (65.6 ft)
Isolation between field power and I/O segment busses	1,000 Vac
Isolation between IO-Link channels	No Isolation
Derating	55 °C...60 °C (131 °F...140 °F): 4 signals are allowed. A signal can be DI, C/Q as input, C/Q as output or IO-Link.

Characteristics of L+ Supply

The following table describes the characteristics of L+ supply of the NTSFIO0400 module:

Characteristics	Value
Maximum current	<ul style="list-style-type: none"> • Channel 0 : 250 mA • Channel 1 : 250 mA • Channel 2 : 200 mA • Channel 3 : 200 mA
Voltage	Depending on the power supply
Short circuit protection	Yes

NOTE: L+ and L- form the 24 Vdc power supply for the IO-Link device.

Characteristics of the C/Q Signal in IO-Link Master Mode

The following table describes the characteristics of the C/Q signal in IO-Link master mode of the NTSFIO0400 module:

Characteristics	Value
Transfer rates	<ul style="list-style-type: none"> • COM1: 4.8 kbaud • COM2: 38.4 kbaud • COM3: 230.4 kbaud
Data format	1 start bit, 8 data bits, 1 parity bit (even), 1 stop bit
Data storage	2048 bytes

NOTE: C/Q is the IO-Link communication line.

Characteristics of C/Q Signal in Discrete Input Mode and DI Signal

The following table describes the characteristics of the C/Q signal in discrete input mode and DI signal of the NTSFIO0400 module:

Characteristics	Value
Input compatibility	Type 3 conforming to IEC 61131-2
Rated input voltage	24 Vdc
Rated input current at 24 Vdc	2.5 mA (minimum 2 mA, maximum 3 mA)
Logic state 0	< 5 Vdc
Logic state 1	> 15 Vdc
Input logic type	Sink
Input filter	Software filter: 1.6 ms, not configurable

Characteristics of the C/Q Signal in Discrete Output Mode

The following table describes the characteristics of the C/Q signal in discrete output mode of the NTSFIO0400 module:

Characteristics	Value
Output type	Push-pull
Output voltage	24 Vdc
Maximum continuous output current	0.2 A per output
Total output current	0.8 A maximum
Maximum overcurrent threshold	Minimum 0.28 A, maximum 0.41 A per output
Output protection	<ul style="list-style-type: none"> • Thermal protection • Short circuit protection • Overcurrent protection <p>NOTE: To restart the channel after an overcurrent event, it is necessary to disconnect the load.</p>

NTSFIO0400 Wiring

Overview

This section provides the wiring diagram of the NTSFIO0400 module.

Wiring Rules

For more information on the wiring, refer to Modicon Edge I/O - System Planning and Installation Guide.

Wiring Diagrams

This module allows the use of an external power supply to energize the sensors.

⚠ WARNING
<p>UNINTENDED EQUIPMENT OPERATION</p> <p>Use the sensor and actuator power supply only for supplying power to sensors or actuators connected to the module.</p> <p>Failure to follow these instructions can result in death, serious injury, or equipment damage.</p>

NTSFIO0400 Wiring diagram IO-Link Class A

The following figure illustrates the connections of the IO-Link device (Class A):

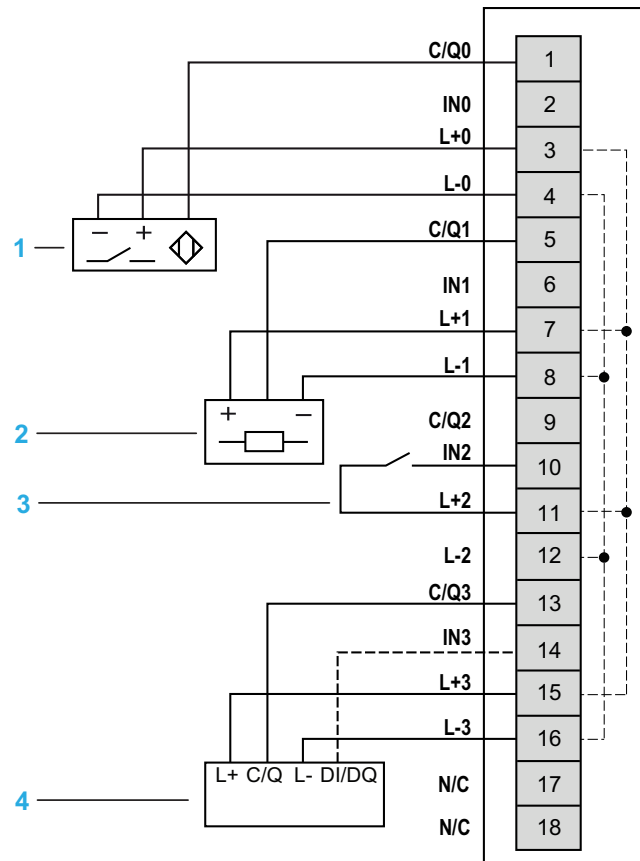

- 1: 3-wire sensor
- 2: 3-wire actuator
- 3: Discrete input
- 4: IO-Link device (Class A) (4 wires)
- N/C: No Connection

⚠ WARNING

UNINTENDED EQUIPMENT OPERATION

Do not connect wires to unused terminals and/or terminals indicated as "No Connection (N/C)".

Failure to follow these instructions can result in death, serious injury, or equipment damage.

NTSFIO0400 Wiring diagram IO-Link Class B with external power supply

The following figure illustrates the connections of the IO-Link device (Class B):

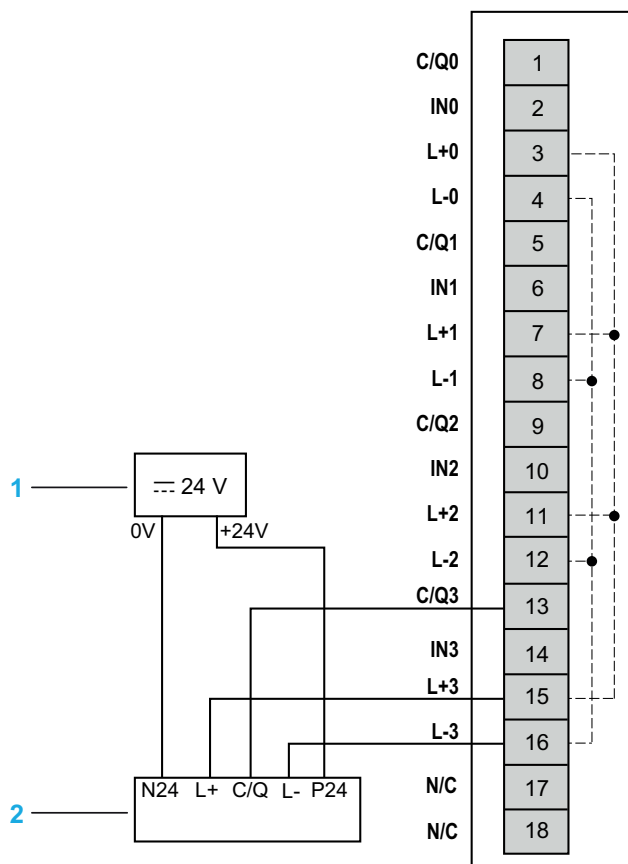

- 1: SELV External power supply isolated from field power
- 2: IO-Link device (Class B) (M12)
- N/C: No Connection

⚠ WARNING
UNINTENDED EQUIPMENT OPERATION
Do not connect wires to unused terminals and/or terminals indicated as “No Connection (N/C)”.
Failure to follow these instructions can result in death, serious injury, or equipment damage.

NTSFIO0400 Parameters

Overview

This section presents the user parameters of the NTSFIO0400 module.

IO-Link Device IODD Import and Selection

Overview

The Modicon Edge I/O Configurator software and the embedded Modicon Edge I/O NTS Web Interface allow you to import the IO-Link device IODD description files for configuration creation or management.

IODD Description Files Import to the Catalog

This submenu allows you to import IO-Link device IODD description files:

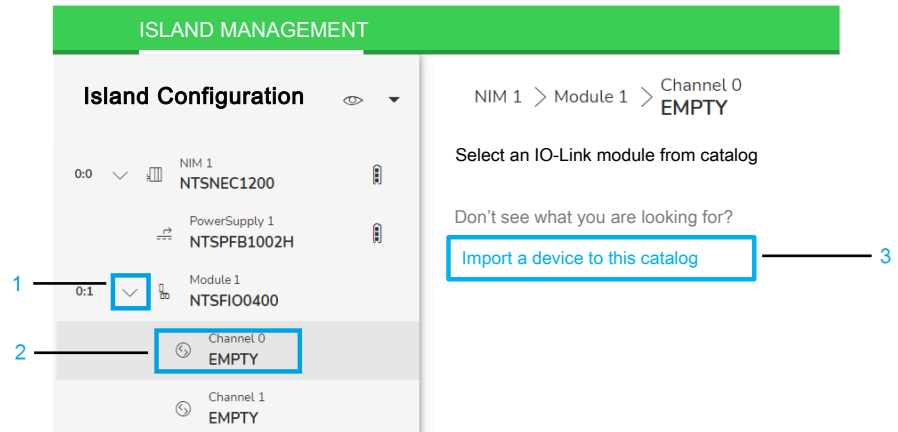

Step	Action
1	In the Island Configuration , expand the list to display the channels of the selected module.
2	Click the Channel .
3	Click Import a device to this catalog . Result: The Windows Open dialog box is displayed.
4	Navigate to the file location and select the IO-Link device IODD description file from your local PC or server. Click Open to confirm the selection.

Add an IO-Link Device

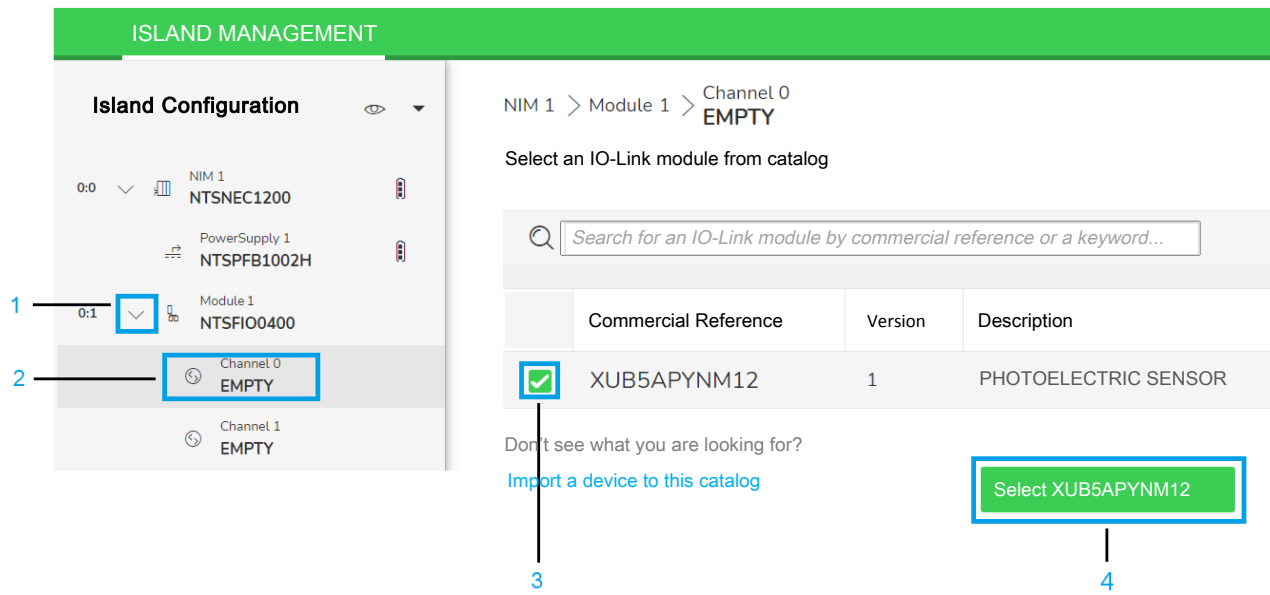

This submenu allows you to add the IO-Link device:



Step	Action
1	In the Island Configuration , expand the list to display the channels of the selected module.
2	Click the Channel to be configured.
3	Select the check box for the IO-Link device to be added to the Channel .
4	Confirm using the Select button.

Device Configuration

After the IO-Link device is imported and added, configure the device parameters of the channel.

Step	Action
1	In the Island Configuration , expand the list to display the channels of the selected module.
2	Click the Channel of the device to be configured. The device parameters are displayed, according to the IODD content.
3	Configure the device parameters. NOTE: Parameters that are not modified are displayed with the value Unset . If you are configuring your device offline, proceed to step 4 only. If you are configuring your device online, skip step 4 and proceed directly to step 5.
4	The following actions are possible while being offline: <ul style="list-style-type: none"> • Configure the device parameters by modifying the value. For more information on possible settings, refer to the device documentation. • The Set to default drop-down list allows you to select one of the following actions: <ul style="list-style-type: none"> ◦ All parameters: All parameters are set to the default values defined in the IODD. ◦ Unset parameters: Parameters that are not modified are set to the default value defined in the IODD. Configured parameters are not modified. • The Unset parameters button allows you to set the device parameters to Unset.
5	The following actions are possible while being online: <ul style="list-style-type: none"> • The Read Values button allows you to read the values configured in the connected device. Two lists of parameters are displayed: <ul style="list-style-type: none"> ◦ PARAMETERS: Parameters that are accessible offline and online. ◦ ONLINE PARAMETERS: Parameters that are accessible only online. • Configure the device parameters by entering or selecting the value. For parameters which type is ButtonT, you can send a command by clicking the corresponding button. For more information on possible settings, refer to the device documentation. <ul style="list-style-type: none"> ◦ To write a parameter value to the device, click  Write online value icon. ◦ To read a parameter value from the device, click  Read online value icon. <p>NOTE: Some IO-Link devices restart when a parameter has been written online. This may lead to an unsuccessful writing if another parameter is written before the restart of the device has completed as the IO-Link device is not accessible.</p> <p>NOTE: If Validation and Backup is set to 3 (Compatible with IO-Link V1.1, datastorage set as backup and restore), the parameters may not be updated as intended.</p> <div style="border: 1px solid black; padding: 10px; text-align: center;"> <p>▲ WARNING</p> <p>UNINTENDED EQUIPMENT OPERATION</p> <p>Verify that the writing of parameters to the IO-Link devices is successfully completed.</p> <p>Failure to follow these instructions can result in death, serious injury, or equipment damage.</p> </div>

Parameters Description

Configurable Parameters

The following table presents the configurable parameters for the NTSFIO0400 module:

Displayed Name <i>Parameter Name</i>	Value	Data type	Description
Device Mode <i>DeviceMode</i>	0: Normal* 1: Optional 2: Virtual reserved	ENUM	Allows you to select the device mode: <ul style="list-style-type: none"> • Normal: The module is part of the software configuration and is physically connected in the cluster. • Optional: The module is part of the software configuration. A dummy module or the configured module must be physically installed in the cluster. Whether either module is present does not cause a configuration error to be detected. • Virtual reserved: The module is part of the software configuration. A dummy module must be physically installed in the cluster. If the virtual module is physically installed in the cluster, a configuration error is detected.
* Parameter default value			

The following table presents the configurable parameters for the channels of the NTSFIO0400 module:

Displayed Name <i>Parameter Name</i>	Value	Data type	Description
Port Mode and CQ behavior <i>PortMode</i>	0*: Deactivated 1: Manual Mode 2: Autostart Mode 3: SIO input Mode 4: SIO output Mode	ENUM	Port mode and C/Q behavior Refer to <i>Port Mode, Validation and Backup Parameters Description</i> , page 34.
Validation and Backup <i>ValidationAndBackup</i>	0*: No device verification 1: Compatible with IO-Link V1.0 2: Compatible with IO-Link V1.1, without datastorage 3: Compatible with IO-Link V1.1, datastorage set as backup and restore 4: Compatible with IO-Link V1.1, datastorage set as restore only	ENUM	IO-Link version and device verification, and data storage configuration <ul style="list-style-type: none"> • 1 and 2: Offline configuration is used. • 3 and 4: Use the datastorage of the IO-Link specification. Refer to <i>Port Mode, Validation and Backup Parameters Description</i> , page 34.
IQ Behavior <i>IQBehavior</i>	0*: Not used 1: Digital input	ENUM	Enables or disables the IN input as a discrete input.
Master cycle time <i>PortCycleTime</i>	0*: Computed fastest master cycle time 1...191: Fixed cycle time	BYTE	Computed cycle time of the data transmission between IO-Link master and IO-Link device at the port. Refer to <i>Master Cycle Time Description</i> , page 34.
Device Id <i>ValidationDeviceId</i>	–	UINT32	Value set by the IODD file and used for validation. Read only parameter
Vendor Id <i>ValidationVendorId</i>	–	UINT16	Value set by the IODD file and used for validation. Read only parameter
Device name <i>DeviceName</i>	–	STRING	Value set by the IODD file. Read only parameter
Vendor name <i>VendorName</i>	–	STRING	Value set by the IODD file. Read only parameter
Input process data length <i>InputProcessDataLength</i>	<ul style="list-style-type: none"> • Number of bytes defined by the IODD if Port Mode and CQ behavior is set to Manual Mode • 32 bytes if Port Mode and CQ behavior is set to Autostart Mode • 0 bytes otherwise 	BYTE	Number of bytes used by <i>IProcessData</i> .
Output process data length <i>OutputProcessData-Length</i>	<ul style="list-style-type: none"> • Number of bytes defined by the IODD if Port Mode and CQ behavior is set to Manual Mode • 32 bytes if Port Mode and CQ behavior is set to Autostart Mode • 0 bytes otherwise 	BYTE	Number of bytes used by <i>QProcessData</i> .
* Parameter default value			

Implicit Data

The following table presents the input implicit data for the NTSFIO0400 module:

<i>Parameter Name</i>	<i>Value</i>	<i>Data type</i> <i>Size in bytes</i>	<i>Description</i>
<i>GCS</i>	0...255	BYTE 1	Group Cyclic Status Bit 0: Data quality Bit 1: General module status Bit 2: I/O status Bit 3: N/A Bit 4: Output status Bit 5: Advisory status Bit 6: N/A Bit 7: Data freshness NOTE: For more information, refer to Modicon Edge I/O - Diagnostic Data - User Guide.
<i>ChannelHealth0_7⁽¹⁾</i>	0...255	BYTE 1	Bit 0...7 = Status of channel 0...7 <ul style="list-style-type: none"> • Bit = FALSE: Channel is invalid or not present. • Bit = TRUE: Channel is valid or disabled.

⁽¹⁾ This parameter is not part of the implicit data if the optimized I/O profile is selected.

The following table presents the input implicit data for the channels of the NTSFIO0400 module:

<i>Parameter Name</i>	<i>Value</i>	<i>Data type</i> <i>Size in bytes</i>	<i>Description</i>
<i>C/Q_Level</i>	FALSE TRUE	BOOL 1	C/Q input level, valid if C/Q is configured as input
<i>DI_Level</i>	FALSE TRUE	BOOL 1	DI level, valid if DI is configured as input
<i>IFifoDiag</i>	Result of the FIFO diagnostic command on 32 bits in High word / Low word format <ul style="list-style-type: none"> • First byte: Administrative information: <ul style="list-style-type: none"> ◦ bit 0: command mirror ◦ bit 1: other diagnostics available in the FIFO • Second byte: value qualifier or 0 if no value • Second word: event code or 0 if no value 	UINT32 4	Result of the FIFO diagnostic command, valid if C/Q is configured as IO-Link
<i>IProcessData</i>	-	BYTE 0...32	IO-Link input process data, valid if C/Q is configured as IO-Link
<i>PortQualifier</i>	-	BYTE 1	Port Qualifier, valid if C/Q is configured as IO-Link

The following table presents the output implicit data for the channels of the NTSFIO0400 module:

Parameter Name	Value	Data type Size in bytes	Description
<i>C/Q_Level</i>	FALSE TRUE	BOOL 1	C/Q output level, valid if C/Q is configured as output
<i>OutputEnabled</i>	FALSE TRUE	BOOL 1	IO-Link output valid from the controller, valid if C/Q is configured as IO-Link
<i>QFifoDiag</i>	FALSE TRUE	BOOL 1	On rising edge, gets the next entry in the FIFO diagnostic queue, valid if C/Q is configured as IO-Link
<i>QProcessData</i>	-	BYTE 0...32	IO-Link output process data, valid if C/Q is configured as IO-Link

Explicit Data

The following table presents the explicit data for the channels of the NTSFIO0400 module:

Parameter Name	Value	Data type Size in bytes	Description
<i>ApplicationSpecificTag</i>	-	STRING 0...32	Application specific tag of the connected IO-Link device
<i>DeviceId</i>	0...FFFFFF hex	UINT32 4	Device ID of the connected IO-Link device
<i>DiagStatus</i>	-	STRING 0...192	Diagnostic status of the connected IO-Link device This parameter provides the list of the IO-Link events. Each event entry is a set of 3 bytes: <ul style="list-style-type: none"> • Byte 1: Event qualifier • Byte 2, 3: Event code Up to 64 array elements are available. Refer to Event Qualifier description, page 33.
<i>InputDataLength</i>	-	BYTE 1	Input data length of the connected IO-Link device
<i>MasterCycle</i>	0*: No device connected 1...255: Fixed cycle time	BYTE 1	Computed cycle time of the data transmission between IO-Link master and IO-Link device at the port All bits at 0: No device connected Bits 0...5: Multiplier (0...63) Bits 6...7: Time base <ul style="list-style-type: none"> • 00: 0.1 ms, with a minimum cycle time of 0.4 ms • 01: 0.4 ms, with a minimum cycle time of 6.4 ms • 10: 1.6 ms, with a minimum cycle time of 32 ms • 11: Reserved
<i>OutputDataLength</i>	-	BYTE 1	Output data length of the connected IO-Link device
<i>PortQualityInfo</i>	Bit 0: Input process data status <ul style="list-style-type: none"> • 0: Valid • 1: Invalid Bit 1: Output process data status <ul style="list-style-type: none"> • 0: Valid • 1: Invalid 	BYTE 1	Port status of the connected IO-Link device

Parameter Name	Value	Data type Size in bytes	Description
<i>PortStatusInfo</i>	0: No active communication (COMLOST state) 1: Port configuration is in DEACTIVATED state. 2: The device is in PREOPERATE state, <i>DiagStatus</i> contains the diagnosis cause. 3: The device is in PREOPERATE state and will go to OPERATE or PORT_DIAG state. 4: The device is in OPERATE state. 5: C/Q is configured as input. 6: C/Q is configured as output. 254: L+ is de-energized. 255: <i>PortStatusInfo</i> is not available.	ENUM 1	Port status information
<i>RevisionId</i>	0: No active communication at that port 1...255	BYTE 1	Revision ID of the connected IO-Link device <ul style="list-style-type: none"> • 00 hex: No device connected • 10 hex: V1.0 • 11 hex: V1.1
<i>SerialNumber</i>	-	STRING 0...32	Serial number of the connected IO-Link device
<i>TransmissionRate</i>	0: No communication at that port 1: COM1 (4.8 kbit/s) 2: COM2 (38.4 kbit/s) 3: COM3 (230.4 kbit/s)	ENUM 1	Transmission rate of the connected device
<i>VendorId</i>	0...FFFF hex	UINT16 2	Vendor ID of the connected IO-Link device

IO-Link Field Device Master Module Appendices

What's in This Chapter

EventQualifier Description.....	33
Port Mode, Validation and Backup Parameters Description.....	34
Master Cycle Time Description	34

EventQualifier Description

The following table presents the structure of the EventQualifier bitfield:

Bits	Value	Description
Bits 0...2 INSTANCE	<ul style="list-style-type: none"> 0: Indeterminable 1...3: Reserved 4: Application 5...7: Reserved 	These bits indicate the instance of an event.
Bit 3 SOURCE	<ul style="list-style-type: none"> 0: Device (remote) 1: Master/Port (local) 	This bit indicates the source of the event.
Bits 4...5 TYPE	<ul style="list-style-type: none"> 0: Reserved 1: Notification 2: Advisory 3: Error 	These bits indicate the type of the event.
Bits 6...7 MODE	<ul style="list-style-type: none"> 0: Reserved 1: Event single shot 2: Event disappears 3: Event appears 	These bits indicate the mode of the event.

Port Mode, Validation and Backup Parameters Description

The following table presents the **Validation and Backup** parameter when the **Port Mode and CQ behavior** is set to **Manual Mode**:

NOTE: Port Mode and CQ behavior parameter can only be set to **Manual Mode** when an IODD is selected for the channel, see IO-Link Device IODD Import and Selection, page 24.

Value	Validation	Offline Configuration	Datastorage
0*: No device verification	None	No	No
1: Compatible with IO-Link V1.0	Vendor ID, Device ID and IO-Link revision V1.0	Yes. Always write into device during startup.	No
2: Compatible with IO-Link V1.1, without datastorage	Vendor ID, Device ID and IO-Link revision V1.1	Yes. Always write into device during startup.	No
3: Compatible with IO-Link V1.1, datastorage set as backup and restore	Vendor ID, Device ID and IO-Link revision V1.1	No	Yes (Backup parameters modifications in Master (e.g. Teaching, Upload-Request). Restore parameters of new device with previously backed up parameters)
4: Compatible with IO-Link V1.1, datastorage set as restore only	Vendor ID, Device ID and IO-Link revision V1.1	No	Yes (Restore modified parameters of the device with previously backed up parameters)

NOTE: Selecting an incorrect IO-Link version may lead to an invalid communication state. Restart the connected device to initialize the communication.

Master Cycle Time Description

The **Master cycle time** bit field defines the cycle time of the data transmission between the IO-Link master and the IO-Link device at the port.

All bits at 0: The IO-Link master uses the computed fastest master cycle time.

Master cycle time selection:

- Bits 0...5: These bits represent a six-bits multiplier for the calculation of the cycle time (0...63).
- Bits 6...7: These bits specify the time base for the calculation of the cycle time.

The following table presents the permissible time base encoding and the corresponding cycle time ranges:

Time base encoding	Time base value	Calculation	Cycle time range
00	0.1 ms	Multiplier x Time base	0.4 ⁽¹⁾ ...6.3 ms
01	0.4 ms	6.4 ms + Multiplier x Time base	6.4...31.6 ms
10	1.6 ms	32.0 ms + Multiplier x Time base	32.0...132.8 ms
11	Reserved	Reserved	Reserved

⁽¹⁾ The value 0.4 ms is the minimum cycle time at a transmission rate of 230.4 kbit/s.

Serial Line Field Device Master Module

What's in This Part

NTSFMB0120/NTSFMB0120H Field Device Master Module, Serial, Modbus RTU, ASCII, Client, 115 Kbps, Standard/Hardened	36
Serial Line Field Device Master Module Appendices	54

NTSFMB0120/NTSFMB0120H Field Device Master Module, Serial, Modbus RTU, ASCII, Client, 115 Kbps, Standard/Hardened

What's in This Chapter

NTSFMB0120/NTSFMB0120H Presentation	36
NTSFMB0120/NTSFMB0120H Characteristics	40
NTSFMB0120/NTSFMB0120H Wiring	41
NTSFMB0120/NTSFMB0120H Parameters	45

NTSFMB0120/NTSFMB0120H Presentation

Overview

This section provides a presentation of the NTSFMB0120/NTSFMB0120H modules.

Main Characteristics

The following table describes the main characteristics of the NTSFMB0120/NTSFMB0120H modules:

Main Characteristics	Value
Product or component type	Serial line module
Serial line types	Serial 2-wire and 4-wire RS-422/RS-485
Supported communication protocols	<ul style="list-style-type: none"> • Modbus RTU⁽¹⁾ • Modbus ASCII⁽¹⁾ • ASCII⁽²⁾
Number of channels	1 serial line Up to 32 Modbus devices can be addressed.
Operating mode	Asynchronous
(1) This mode supports Modbus scanner and explicit messages. (2) This mode requires explicit messages. NOTE: Explicit messages use OPC UA method calls. Verify that your controller supports OPC UA method calls.	

Purchasing Information

The following figure presents the elements of the NTSFMB0120/NTSFMB0120H modules:

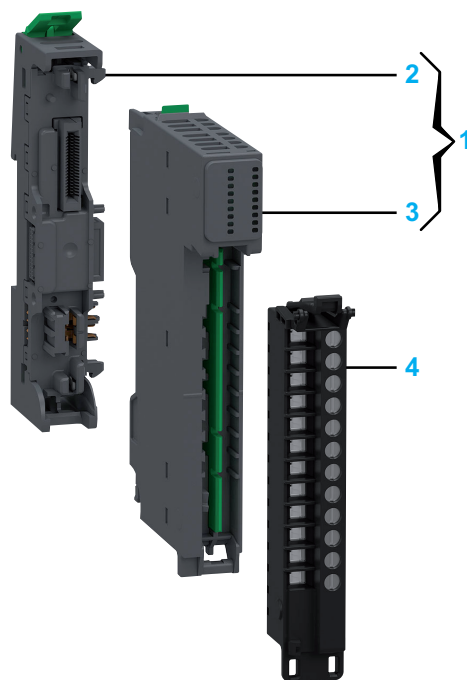

Number	Reference	Description
1	NTSFMB0120K/ NTSFMB0120HK	Base + Module (kit) NOTE: The module and its corresponding base can be purchased as a kit.
2	NTSXBA0100H	Spare Base, 1 Slot, for Input/Output Common or Expert Module, Hardened
3	NTSFMB0120 NTSFMB0120H	Field Device Master Module, Serial, Modbus RTU, ASCII, Client, 115 Kbps Field Device Master Module, Serial, Modbus RTU, ASCII, Client, 115 Kbps, Hardened
4	NTSXTB12200H NTSXTB12201H NTSXTB12000H NTSXTB12001H	Spring Terminal Block, 12 Points, 5 mm Pitch, Without Cover, use on Low Height Module, Hardened Spring Terminal Block, 12 Points, 5 mm Pitch, With Cover, use on Low Height Module, Hardened Screw Terminal Block, 12 Points, 5 mm Pitch, Without Cover, use on Low Height Module, Hardened Screw Terminal Block, 12 Points, 5 mm Pitch, With cover, use on Low Height Module, Hardened NOTE: The terminal blocks are purchased separately.

NOTE: For more information on accessories and spare parts, refer to Modicon Edge I/O - System Planning and Installation Guide.

Physical Description

The following figure presents the elements of the module:

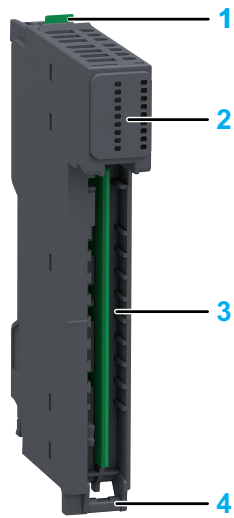

- 1: Release button for disengaging the module from the base
- 2: Status LEDs
- 3: Slot for the terminal block
- 4: Hinge for the terminal block installation

Status LEDs

The following figure presents the NTSFMB0120/NTSFMB0120H status LEDs:

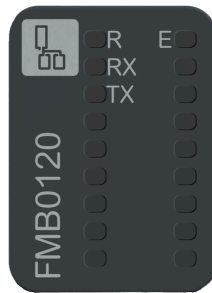

The following table describes the status of LEDs:

R (Green)	E (Red)	RX, TX (Green)	Description
Initialization and non-operational states			
OFF	OFF	OFF	Indicates that the module is not energized.
OFF	ON	-	Indicates that the module has detected a system error.
Regular Flash	OFF	-	Indicates that the firmware is being updated.
Regular Flash	ON	-	Indicates that a module mismatch is detected.
Single Flash	OFF	-	Indicates that the module is energized and not configured.
Operational state			
ON	OFF	-	Indicates that the module is energized, configured and operational.
Fast Flash	-	-	Indicates that the Modbus I/O scanner is stopped.
ON	Regular Flash	-	Indicates an advisory detection.
ON	Regular Flash	OFF	Indicates that a 24 Vdc field power error is detected.
ON	Regular Flash	Regular Flash	Indicates that the module is in fallback state.
ON	ON	-	Indicates that a module-related error is detected.
ON	OFF	Fast Flash	Indicates an activity on the serial line port: <ul style="list-style-type: none"> • RX: receive • TX: transmit

NOTE: For an extended diagnostic, refer to the Modicon Edge I/O - Diagnostic Data - User Guide

The following graphic shows the system status of LEDs during module operation:

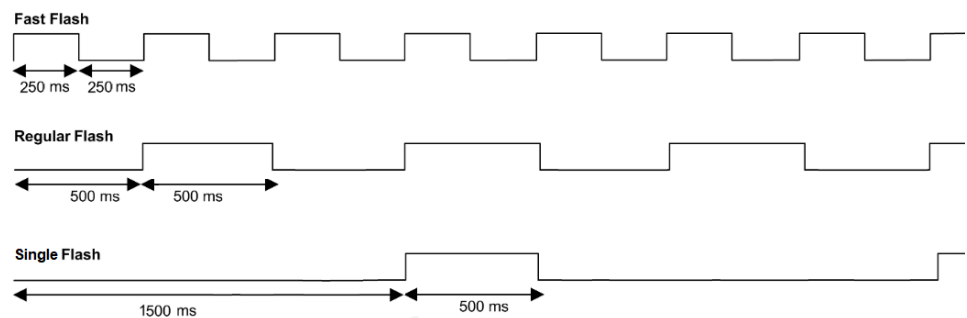

NTSFMB0120/NTSFMB0120H Characteristics

Overview

This section provides a general description of the characteristics of the module.

⚠ WARNING

UNINTENDED EQUIPMENT OPERATION

Do not exceed any of the rated values specified in the environmental and electrical characteristics tables.

Failure to follow these instructions can result in death, serious injury, or equipment damage.

For more information on environmental characteristics, refer to Modicon Edge I/O - System Planning and Installation Guide.

Dimensions

The following figure presents the external dimensions of the assembled module:

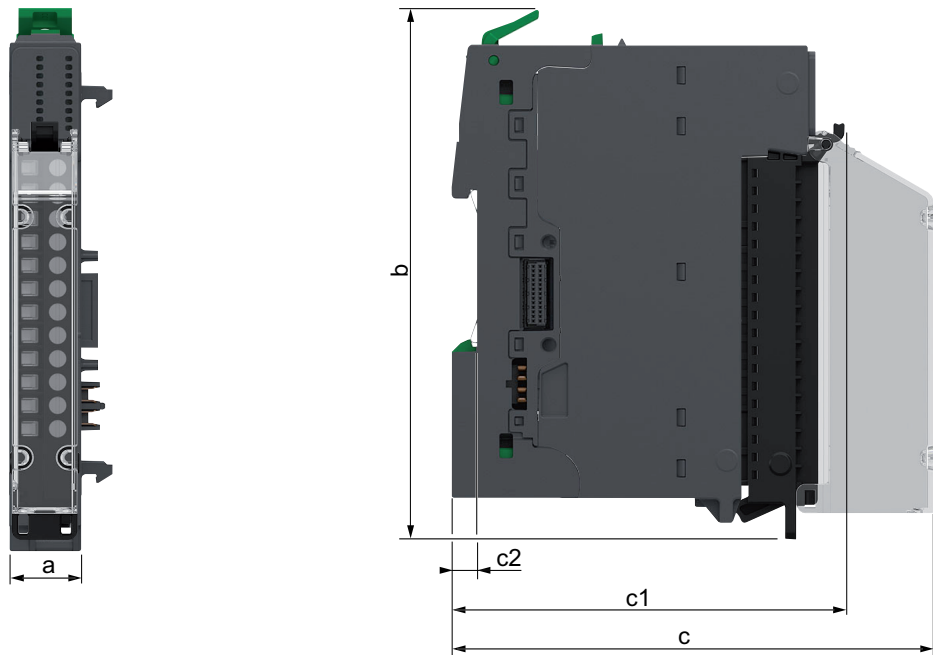

- a:** 15 mm (0.59 in)
- b:** 116.6 mm (4.57 in)
- c:** 107.5 mm (4.21 in)
- c1:** 88.2 mm (3.46 in)
- c2:** 5.6 mm (0.2 in)

Weight

- NTSFMB0120: 49 g (1.73 oz)
- NTSFMB0120K: 76 g (2.68 oz)
- NTSFMB0120H: 49 g (1.73 oz)
- NTSFMB0120HK: 76 g (2.68 oz)

General Characteristics

The following table describes the general characteristics of the module:

Characteristics	Value
Rated supplied voltage	24 Vdc
Power supply source	Connected to the 24 Vdc field power segment
Power supplied voltage range	20.4...28.8Vdc
24 Vdc I/O segment current draw	28.8 mA
Power dissipation	1.44 W
Maximum cable length	1,200 m (3,937 ft)
Isolation between field power and bus	1,000 Vac
Isolation between field power and serial port	1,500 Vac

Serial Line Characteristics

Characteristics	Value
Line polarization	The line polarization is embedded into the module and can be enabled with the Serial line type parameter.
Line termination	The line termination resistor can be externally connected to the LTA/B and LTY/Z pins of the terminal block.

NTSFMB0120/NTSFMB0120H Wiring

Overview

This section provides the wiring diagram of the NTSFMB0120/NTSFMB0120H modules.

Wiring Rules

For more information on the wiring, refer to Modicon Edge I/O - System Planning and Installation Guide.

Wiring Diagrams

RS-422/RS-485 2-Wire Wiring Diagrams

The following figure illustrates the connections of the RS-485 2-wire devices:

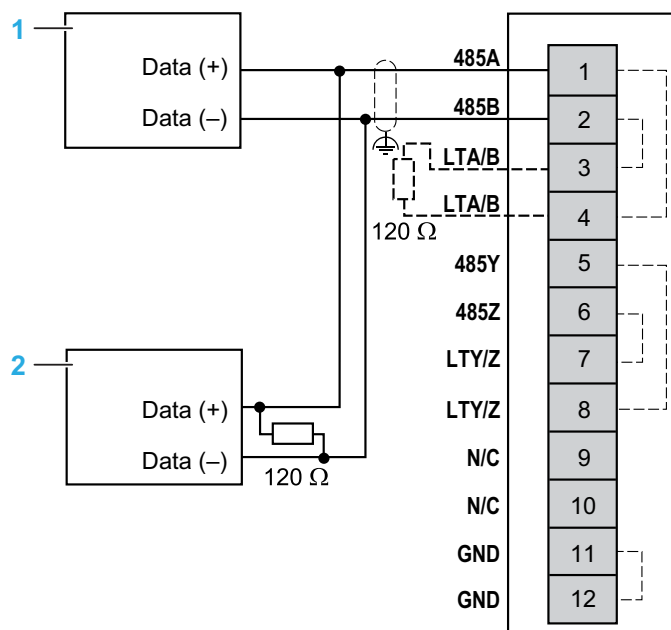

1, 2: RS-485 2-wire devices
 N/C: No Connection

⚠ WARNING

UNINTENDED EQUIPMENT OPERATION

Do not connect wires to unused terminals and/or terminals indicated as “No Connection (N/C)”.

Failure to follow these instructions can result in death, serious injury, or equipment damage.

The following figure illustrates the connections of the RS-422/RS-485 2-/4-wire devices:

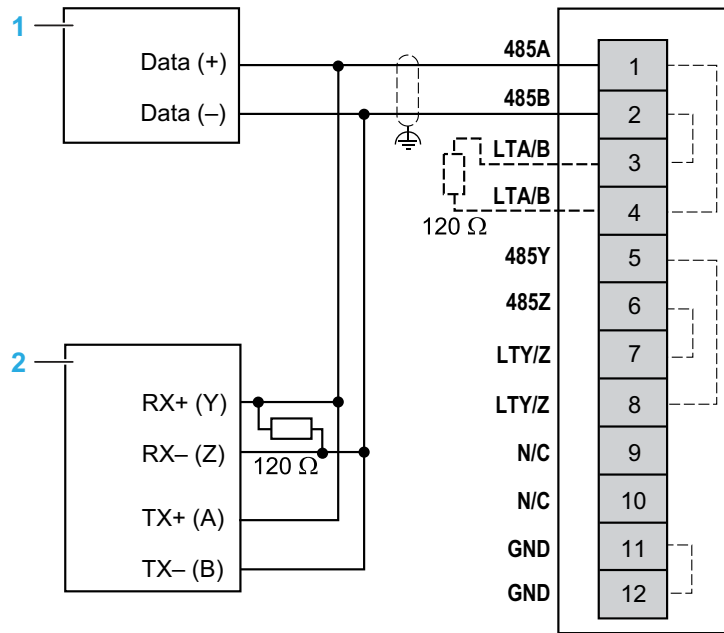

- 1: RS-485 2-wire device
- 2: RS-422 4-wire device
- N/C: No Connection

⚠ WARNING

UNINTENDED EQUIPMENT OPERATION

Do not connect wires to unused terminals and/or terminals indicated as “No Connection (N/C)”.

Failure to follow these instructions can result in death, serious injury, or equipment damage.

RS-422/RS-485 4-Wire Wiring Diagrams

The following figure illustrates the connections of the RS-422 4-wire devices:

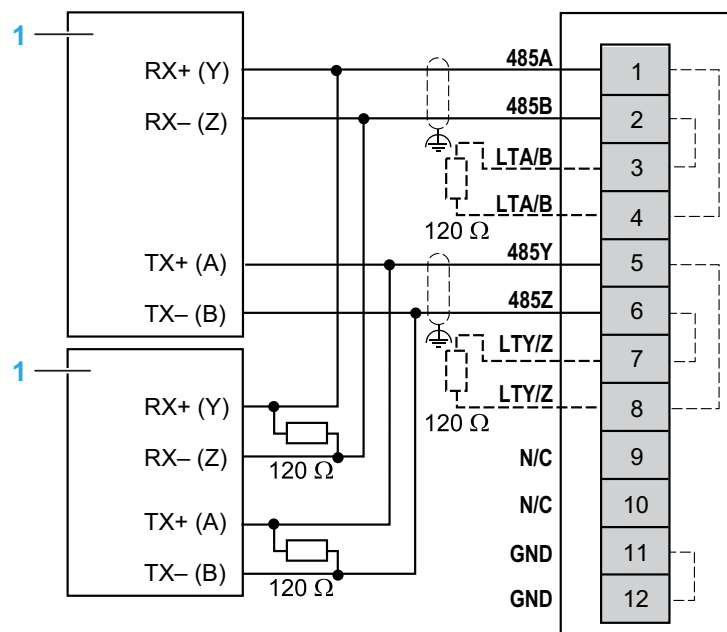

1: RS-422 4-wire device
 N/C: No Connection

⚠ WARNING

UNINTENDED EQUIPMENT OPERATION

Do not connect wires to unused terminals and/or terminals indicated as "No Connection (N/C)".

Failure to follow these instructions can result in death, serious injury, or equipment damage.

The following figure illustrates the connections of the RS422/RS-485 2-/4-wire devices:

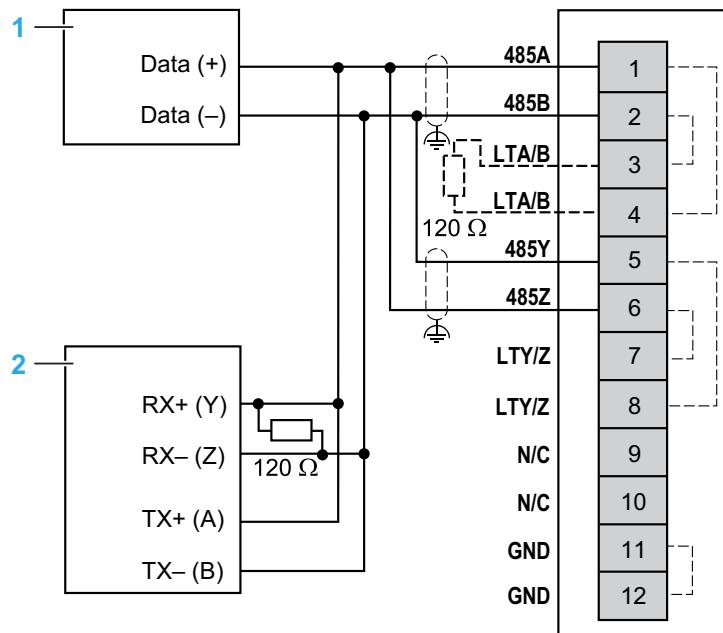

- 1: RS-485 2-wire device
- 2: RS-422 4-wire device
- N/C: No Connection

⚠ WARNING
UNINTENDED EQUIPMENT OPERATION
Do not connect wires to unused terminals and/or terminals indicated as “No Connection (N/C)”.
Failure to follow these instructions can result in death, serious injury, or equipment damage.

NTSFMB0120/NTSFMB0120H Parameters

Overview

This section presents the user parameters of the NTSFMB0120/NTSFMB0120H modules.

Generic Fieldbus Device

Overview

The Modicon Edge I/O Configurator software and the embedded Modicon Edge I/O NTS Web Interface allow you to import a generic fieldbus device in your configuration.

Add a Fieldbus Device

The following table describes the steps to add a generic Modbus serial device in your configuration:

Step	Action
1	In the Island Configuration , select the serial line module.
2	In the Island Configuration , click + Add Module .
3	Click Add a Fieldbus Device .
4	Confirm using the Add Modbus Serial Device button.

NOTE: You can add up to 32 fieldbus devices per serial line module.

Device Configuration

After the fieldbus device is added, configure the parameters of the serial device.

Modbus Serial Device Settings

The following table presents the **DEVICE PARAMETERS** settings for the Modbus serial device:

Displayed Name	Value	Data type	Description
Device Address	1*...247	BYTE	Sets the address of the Modbus device.
* Parameter default value			

The following table presents the **INITIALIZATION COMMANDS** settings for the Modbus serial device:

Displayed Name	Value	Data type	Description
Access Type	Write Single Coil (Function Code 05)* Write Single Register (Function Code 06) Write Multiple Coils (Function Code 15) Write Multiple Register (Function Code 16)	ENUM	Selects the access type.
Register Offset	0 hex*...FFFF hex	UINT16	Sets the register offset.
Length	1* for function codes 05 and 06 1*...1,968 for function code 15 1*...123 for function code 16	UINT16	Sets the number of objects to write: <ul style="list-style-type: none"> For function codes 05 and 15: number of bits. For function codes 06 and 16: number of registers.
Initialization Value	0*...1 for function codes 05, 15 0*...65,535 for function codes 06, 16	UINT16	Sets the initialization value of the command. For function codes 15 and 16, the same initialization value applies to each object.
* Parameter default value			

Click **Add an Initialization Command** to add up to 10 commands. Drag and drop the commands in the list to modify the order of execution.

Configured initialization commands are executed when the serial line module is started or when a configured device is restarted.

Refer to *Modbus Scanner Operating Mode*, page 54.

The following table presents the **MODBUS CHANNELS** settings for the Modbus serial device:

Displayed Name	Value	Data type	Description
Name	-	STRING	Sets the Modbus channel name.
Access Type	Read Coils (Function Code 01) Read Discrete Inputs (Function Code 02) Read Holding Registers (Function Code 03) Read Input Registers (Function Code 04) Write Single Coil (Function Code 05) Write Single Register (Function Code 06) Write Multiple Coils (Function Code 15) Write Multiple Register (Function Code 16) Read/Write Multiple Register (Function Code 23)*	ENUM	Selects the access type.
Trigger	Cyclic*	BYTE	Selects the trigger type (fixed value) for command execution.
Cycle Time (in ms)	1...65,535 100*	UINT16	Sets the cycle time for command execution.
Read Offset	0 hex*...FFFF hex	UINT16	Sets the read offset. NOTE: This parameter is editable for function codes 01, 02, 03, 04, and 23.
Read Length	1*...2,000 for function codes 01 and 02 1*...125 for function codes 03, 04, and 23	BYTE	Sets the number of objects to read: <ul style="list-style-type: none"> For function codes 01 and 02: number of bits. For function codes 03, 04, and 23: number of registers. NOTE: This parameter is editable for function codes 01, 02, 03, 04, and 23.
Error Handling	Keep last value* Set to zero	ENUM	Selects the reaction to a detected error. NOTE: This parameter is editable for function codes 01, 02, 03, 04, and 23.
Write Offset	0 hex*...FFFF hex	UINT16	Sets the write offset. NOTE: This parameter is editable for function codes 05, 06, 15, 16, and 23.
Write Length	1* for function codes 05 and 06 1*...1,920 for function code 15, 1*...120 for function codes 16 and 23	BYTE	Sets the number of objects to write: <ul style="list-style-type: none"> For function codes 05 and 15: number of bits. For function codes 06, 16, and 23: number of registers. NOTE: This parameter is editable for function codes 15, 16, and 23. This parameter is forced to 1 for function codes 05 and 06.
* Parameter default value			

Click **Add a Modbus Channel** to add up to 5 Modbus channels. Drag and drop the Modbus channels in the list to modify the order of execution.

Modbus commands are executed cyclically after the device is started and initialization commands are executed.

Refer to Modbus Scanner Operating Mode, page 54.

Input and output implicit process data allocation:

- Function codes 03, 04, 06, 16, and 23: 2 bytes per register are allocated in the implicit process data.

The number of registers is set by the **Read Length** and **Write Length** parameters.

Register values are accessible in the *IProcessData* and *QProcessData* implicit parameters.

- Function codes 01, 02, and 15: (Number of bits + 7) / 8 bytes are allocated in the implicit process data.

The number of bits is set by the **Read Length** and **Write Length** parameters.

Discrete input or coil values are accessible on the corresponding bit in the *IProcessData* and *QProcessData* implicit parameters.

- Function code 05: 1 byte is allocated in the output implicit process data.

The number of objects is forced to 1 in the **Write Length** parameter.

The coil value is accessible in the *QProcessData* implicit parameter.

Any value other than 0 is considered as setting the coil to value 1.

Parameters Description

Configurable Parameters

The following table presents the configurable parameters for the NTSFMB0120/NTSFMB0120H modules:

Displayed Name <i>Parameter Name</i>	Value	Data type	Description
Device Mode <i>DeviceMode</i>	0: Normal* 1: Optional 2: Virtual reserved	ENUM	Allows you to select the device mode: <ul style="list-style-type: none"> Normal: The module is part of the software configuration and is physically connected in the cluster. Optional: The module is part of the software configuration. A dummy module or the configured module must be physically installed in the cluster. Whether either module is present does not cause a configuration error to be detected. Virtual reserved: The module is part of the software configuration. A dummy module must be physically installed in the cluster. If the virtual module is physically installed in the cluster, a configuration error is detected.
* Parameter default value			

The following table presents the configurable parameters for the Modbus serial devices connected to the NTSFMB0120/NTSFMB0120H modules:

Displayed Name <i>Parameter Name</i>	Value	Data type	Description
Serial line type <i>Bus_Type</i>	0*: RS485/RS422 2-wire - line polarization enabled 1: RS485/RS422 2-wire - line polarization disabled 2: RS485/RS422 4-wire - line polarization enabled on A/B & Y/Z 3: RS485/RS422 4-wire - line polarization disabled on A/B & Y/Z	ENUM	Selects the serial line type.
Baud rate <i>Baudrate</i>	1,200: 1200 2,400: 2400 4,800: 4800 9,600: 9600 19,200: 19200 38,400: 38400 57,600: 57600 115,200*: 115200	ENUM	Selects the baud rate in bauds.
Parity <i>Parity</i>	0: None 1: Odd 2*: Even	ENUM	Selects the parity.
Data bits <i>Databits</i>	7: 7 8*: 8	ENUM	Selects the number of data bits: NOTE: <ul style="list-style-type: none"> Always 7 if the selected Protocol mode is Modbus ASCII. Always 8 if the selected Protocol mode is Modbus RTU.
Stop bits <i>Stopbits</i>	1*: 1 Stopbit 2: 2 Stopbits	ENUM	Selects the number of stop bits.
Protocol mode <i>Protocol mode</i>	0*: Modbus RTU 1: Modbus ASCII 2: ASCII⁽³⁾	ENUM	Selects the protocol.
Time between frames <i>Interframe_time⁽²⁾</i>	1...65,535 10*	UINT16	Sets the minimum time in ms between frames sent by the module. NOTE: The minimum value depends on the selected Baud rate value.
Response timeout <i>Response_timeout⁽²⁾</i>	1...65,535 500*	UINT16	Sets the timeout in ms for a cyclic request.
Transaction timeout <i>Transactiontimeout</i>	1...65,535 5,000*	UINT32	Sets the timeout in ms for a transaction request.
Start/Stop scanner <i>Start_Stop_Scanner⁽¹⁾⁽²⁾</i>	FALSE TRUE*	BOOLEAN	Selects whether the scanner is enabled or disabled: <ul style="list-style-type: none"> FALSE: The scanner is disabled. TRUE: The scanner is enabled.

Field Device Master Modules

Displayed Name <i>Parameter Name</i>	Value	Data type	Description
Start/Stop channels <i>Start_Stop_Channels</i> ⁽¹⁾⁽²⁾	0...4,294,967,295*	UINT32	Sets whether the Modbus serial devices are enabled or disabled. Bit 0...31 = Status of the devices 0...31: <ul style="list-style-type: none"> • Bit = FALSE: The device is disabled. • Bit = TRUE: The device is enabled.
<p>* Parameter default value</p> <p>(1) Online modification is allowed.</p> <p>(2) Parameter not available if the selected Protocol mode is ASCII.</p> <p>(3) This mode requires explicit messages to be sent using OPC UA method calls. Verify that your controller supports OPC UA method calls.</p>			

Implicit Data

The following table presents the input implicit data for the NTSFMB0120/
NTSFMB0120H modules:

Parameter Name	Value	Data type Size in bytes R/W	Description
GCS	0...255	BYTE 1 R/-	Group Cyclic Status Bit 0: Data quality Bit 1: General module status Bit 2: I/O status Bit 3: N/A Bit 4: Output status Bit 5: Advisory status Bit 6: N/A Bit 7: Data freshness NOTE: For more information, refer to Modicon Edge I/O - Diagnostic Data - User Guide.
<i>ChannelHealth0_7</i> ⁽¹⁾	0...255	BYTE 1 R/-	Bit 0...7 = Status of device 0...7 <ul style="list-style-type: none"> • Bit = FALSE: The device returns invalid data or the device is not responding. • Bit = TRUE: The device returns valid data or the device is not configured.
<i>ChannelHealth8_15</i> ⁽¹⁾	0...255	BYTE 1 R/-	Bit 0...7 = Status of device 8...15 <ul style="list-style-type: none"> • Bit = FALSE: The device returns invalid data or the device is not responding. • Bit = TRUE: The device returns valid data or the device is not configured.
<i>ChannelHealth16_23</i> ⁽¹⁾	0...255	BYTE 1 R/-	Bit 0...7 = Status of device 16...23 <ul style="list-style-type: none"> • Bit = FALSE: The device returns invalid data or the device is not responding. • Bit = TRUE: The device returns valid data or the device is not configured.
<i>ChannelHealth24_31</i> ⁽¹⁾	0...255	BYTE 1 R/-	Bit 0...7 = Status of device 24...31 <ul style="list-style-type: none"> • Bit = FALSE: The device returns invalid data or the device is not responding. • Bit = TRUE: The device returns valid data or the device is not configured.

⁽¹⁾ This parameter is not part of the implicit data if the optimized I/O profile is selected.

For more information about the available diagnostic data in specific cases, refer to Diagnostic Data, page 55.

The following table presents the input implicit data for the Modbus serial devices connected to the NTSFMB0120/NTSFMB0120H modules:

Parameter Name	Value	Data type Size in bytes R/W	Description
<i>IProcessData</i>	-	BYTE 0...1024 R/-	Process data combined from the Modbus channels of a serial device

The following table presents the output implicit data for the NTSFMB0120/NTSFMB0120H modules:

Parameter Name	Value	Data type Size in bytes R/W	Description
<i>RestartCh0_7</i>	0...255	BYTE 1 R/W	Bit 0...7 = Enables or disables the communication with the Modbus serial device 0...7. <ul style="list-style-type: none"> • Bit = TRUE: The communication with the Modbus serial device is enabled. • Bit = FALSE: The communication with the Modbus serial device is disabled.
<i>RestartCh8_15</i>	0...255	BYTE 1 R/W	Bit 0...7 = Enables or disables the communication with the Modbus serial device 8...15. <ul style="list-style-type: none"> • Bit = TRUE: The communication with the Modbus serial device is enabled. • Bit = FALSE: The communication with the Modbus serial device is disabled.
<i>RestartCh16_23</i>	0...255	BYTE 1 R/W	Bit 0...7 = Enables or disables the communication with the Modbus serial device 16...23. <ul style="list-style-type: none"> • Bit = TRUE: The communication with the Modbus serial device is enabled. • Bit = FALSE: The communication with the Modbus serial device is disabled.
<i>RestartCh24_31</i>	0...255	BYTE 1 R/W	Bit 0...7 = Enables or disables the communication with the Modbus serial device 24...31. <ul style="list-style-type: none"> • Bit = TRUE: The communication with the Modbus serial device is enabled. • Bit = FALSE: The communication with the Modbus serial device is disabled.

The following table presents the output implicit data for the Modbus serial devices connected to the NTSFMB0120/NTSFMB0120H modules:

<i>Parameter Name</i>	<i>Value</i>	<i>Data type</i> <i>Size in bytes</i> <i>R/W</i>	<i>Description</i>
<i>QProcessData</i>	-	BYTE 0...1024 R/W	Process data combined from the Modbus channels of a serial device

Explicit Data

The following table presents the explicit data for the Modbus serial devices connected to the NTSFMB0120/NTSFMB0120H modules:

<i>Parameter Name</i>	<i>Value</i>	<i>Data type</i> <i>Size in bytes</i> <i>R/W</i>	<i>Description</i>
<i>Device State</i>	0: Reserved 1: Initial state 2: The initialization commands are being executed. 3: A communication interruption occurs during initialization. 4: The Modbus channels are being started. 5: The Modbus channels are in operation. 6: A communication interruption occurs during operation. 7...255: Reserved	BYTE 1 R/-	Modbus serial device state NOTE: If <i>Device State</i> equals 6, restart communication with the connected device by toggling from FALSE to TRUE the corresponding bit of the parameter <i>RestartCh0_7</i> , <i>RestartCh8_15</i> , <i>RestartCh16_23</i> , or <i>RestartCh24_31</i> .
<i>Start_Stop_Scanner</i> ⁽¹⁾	FALSE TRUE*	BOOLEAN R/W	Selects whether the scanner is enabled or disabled: <ul style="list-style-type: none"> FALSE: The scanner is disabled. TRUE: The scanner is enabled.
<i>Start_Stop_Channels</i> ⁽¹⁾	0...4,294,967,295*	UINT32 R/W	Sets whether Modbus serial devices are enabled or disabled. Bit 0...31 = Status of device 0...31: <ul style="list-style-type: none"> Bit = FALSE: The device is disabled. Bit = TRUE: The device is enabled.

* Parameter default value

(1) Parameter not available if the selected **Protocol mode** is **ASCII**.

Serial Line Field Device Master Module Appendices

What's in This Chapter

Modbus Scanner Operating Mode 54
 Diagnostic Data..... 55

Modbus Scanner Operating Mode

The following state diagram presents the operating mode of the Modbus scanner for a device:

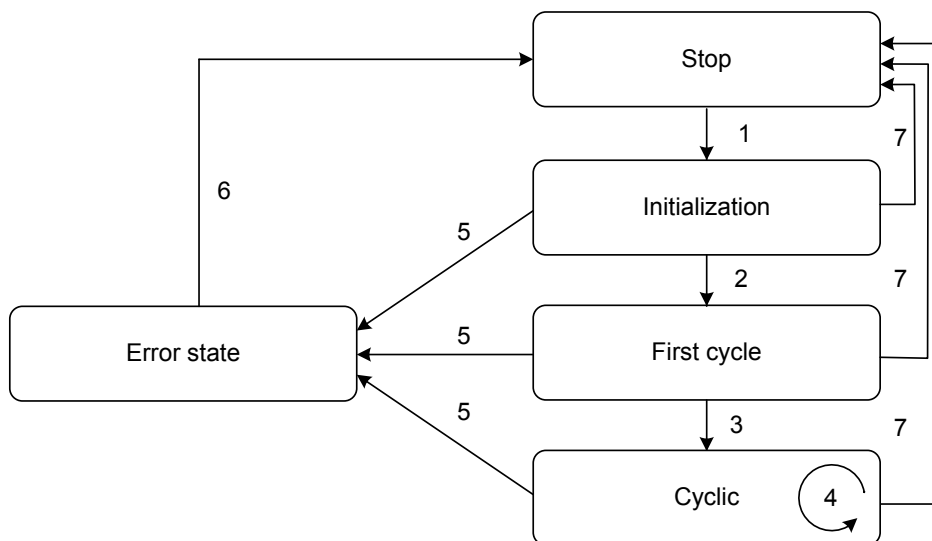

State	Operations
Stop	The communication with the device is stopped.
Initialization	The communication with the device starts. Configured initialization commands are sent.
First cycle	The first configured cyclic entry is sent to the device. The corresponding bit of the <i>ChannelHealth</i> is set to FALSE.
Cyclic	The configured cyclic entries are sent to the device. The corresponding bit of the <i>ChannelHealth</i> is set to TRUE.
Error state	The communication with the device is stopped. The corresponding bit of the <i>ChannelHealth</i> is set to FALSE.

Transition	Conditions
1	The following conditions are met: <ul style="list-style-type: none"> No fallback request is received from the network interface module.⁽¹⁾ Start/Stop scanner parameter is TRUE. The corresponding bit of the Start/Stop channels parameter is TRUE. The corresponding bit of the <i>RestartCh</i> is TRUE. No 24 Vdc field power error is detected.
2	Configured initialization commands are successfully sent.
3	The first cyclic entry is successfully sent to the device.
4	The cyclic entries are successfully sent to the device.
5	A communication interruption on the serial line is detected after three attempts and no 24 Vdc field power error is detected.
6	One of the following conditions is met: <ul style="list-style-type: none"> A fallback request is received from the network interface module.⁽¹⁾ Start/Stop scanner parameter is FALSE. The corresponding bit of the Start/Stop channels parameter is FALSE. The corresponding bit of the <i>RestartCh</i> is FALSE.

Transition	Conditions
7	One of the following conditions is met: <ul style="list-style-type: none"> • A fallback request is received from the network interface module.⁽¹⁾ • A communication interruption on the serial line is detected after three attempts and a 24 Vdc field power error is detected. • Start/Stop scanner parameter is FALSE. • The corresponding bit of the Start/Stop channels parameter is FALSE. • The corresponding bit of the <i>RestartCh</i> is FALSE.
(1) A communication interruption with the controller or <i>Island_Commands</i> parameter bit 15 set to TRUE leads to a fallback request to the module.	

Diagnostic Data

The following list provides information for the diagnostic data:

- If a device is not configured, the corresponding bit of the *ChannelHealth* is TRUE regardless of the status of the Modbus scanner.
- If a device is configured:
 - If the configured cyclic entries are successfully sent to the device, the corresponding bit of the *ChannelHealth* is set to TRUE.
 - If the cyclic entries are not configured, the corresponding bit of the *ChannelHealth* is set to TRUE.
- If data exchange with a device is performed through explicit messages:
 - The corresponding bit of the *ChannelHealth* is not updated.
 - The status of the explicit exchanges does not modify the *GCS* parameter.

NOTE: If **Protocol mode** is set to **ASCII**, the data exchange with the configured device is performed through explicit exchanges.

Index

F

Fieldbus Device45

I

IO-Link Fieldbus Modules

NTSFIO0400 14

IODD 24

S

Serial Line Fieldbus Modules

NTSFMB0120 36

NTSFMB0120H 36

Schneider Electric
35 rue Joseph Monier
92500 Rueil Malmaison
France

www.se.com

As standards, specifications, and design change from time to time, please ask for confirmation of the information given in this publication.

© 2026 Schneider Electric. All rights reserved.

EIO0000005270.02