

Modicon Edge I/O NTS

System Planning and Installation Guide

Original instructions

EIO0000004786.05

02/2026

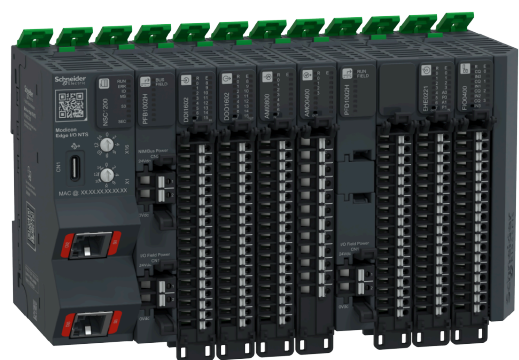

Legal Information

The information provided in this document contains general descriptions, technical characteristics and/or recommendations related to products/solutions.

This document is not intended as a substitute for a detailed study or operational and site-specific development or schematic plan. It is not to be used for determining suitability or reliability of the products/solutions for specific user applications. It is the duty of any such user to perform or have any professional expert of its choice (integrator, specifier or the like) perform the appropriate and comprehensive risk analysis, evaluation and testing of the products/solutions with respect to the relevant specific application or use thereof.

The Schneider Electric brand and any trademarks of Schneider Electric SE and its subsidiaries referred to in this document are the property of Schneider Electric SE or its subsidiaries. All other brands may be trademarks of their respective owner.

This document and its content are protected under applicable copyright laws and provided for informative use only. No part of this document may be reproduced or transmitted in any form or by any means (electronic, mechanical, photocopying, recording, or otherwise), for any purpose, without the prior written permission of Schneider Electric.

Schneider Electric does not grant any right or license for commercial use of the document or its content, except for a non-exclusive and personal license to consult it on an "as is" basis.

Schneider Electric reserves the right to make changes or updates with respect to or in the content of this document or the format thereof, at any time without notice.

To the extent permitted by applicable law, no responsibility or liability is assumed by Schneider Electric and its subsidiaries for any errors or omissions in the informational content of this document, as well as any non-intended use or misuse of the content thereof.

Table of Contents

Safety Information	7
Before You Begin	7
Start-up and Test	8
Operation and Adjustments	9
About the Document	10
Introduction to the Modicon Edge I/O	15
Modicon Edge I/O Overview	16
Modicon Edge I/O System	16
Modicon Edge I/O NTS Main Cluster	18
Modicon Edge I/O NTS Network Interface Module (NIM)	19
Modicon Edge I/O NTS Power Supply (PFB and PFD)	19
Modicon Edge I/O NTS Modules	20
Modicon Edge I/O NTS Accessories	21
Modicon Edge I/O Network Structure with Modbus TCP and EtherNet/IP	22
Modicon Edge I/O Network Structure with Sercos III	23
Modicon Edge I/O NTS Modules	25
Network Interface Modules	25
Discrete Input Modules	25
Discrete Output Modules	26
Analog Input Modules	28
Analog Output Modules	29
Analog Mixed Input/Output Modules	30
Counting Input Modules	30
Counting Input/Output Modules	31
Motion Expert Modules	32
Field Device Master Modules	33
Power Supply Modules	33
Common Distribution Modules	33
Dummy Module	33
Modicon Edge I/O NTS Accessories	34
Spare Bases	35
Spare Cluster Termination	35
Spare Cover for Terminal Block	35
Other Accessories	35
Initial Planning Considerations	36
Operating Environment	37
Introduction	37
Enclosure Requirements	37
Environmental Characteristics	37
Electromagnetic Susceptibility	39
Certifications and Standards	40
Mechanical Requirements	41
Enclosing the Modicon Edge I/O NTS	41
Clearance Requirements	41
Thermal Considerations	42
Mounting Positions	43
Correct Mounting Position	43

Acceptable Mounting Positions.....	44
Incorrect Mounting Position.....	45
Modicon Edge I/O NTS Power Distribution	46
Power Distribution Description	46
Power Supply Module Mounting Rules.....	47
Power Distribution System Implementation	47
Current Consumed on the 24 Vdc Bus	48
Current Consumed on the 24 Vdc Field Power Segment	48
Electrical Requirements	49
Wiring Best Practices	49
Characteristics of the 24 Vdc Bus Power Supply	53
Characteristics of the 24 Vdc Field Power Supply	53
Calculating the Power Supply Requirement	53
Grounding the system.....	54
Overview.....	54
Protective Ground (PE) on the Backplane.....	55
Functional Ground (FE) on the DIN Rail.....	55
Shielded Cables Connections	56
Installation Procedures	57
Installation and Maintenance Requirements	58
Before Starting	58
Disconnecting Power	58
Programming Considerations.....	59
Operating Environment Considerations	59
Installation Considerations.....	59
Installation Walkthrough.....	60
Overview.....	60
Installation - Phase 1.....	60
Installation - Phase 2.....	60
Installation - Phase 3.....	61
The Layout of your Modicon Edge I/O NTS Island	62
Planning the Installation	62
Selecting Modicon Edge I/O NTS Modules.....	62
DIN Rail Installation	64
Grounding Function	64
Mounting the DIN Rail	64
DIN Rail End Stoppers	65
Network Interface Module Installation.....	66
Mounting a Network Interface Module Kit on the DIN Rail.....	67
Removing a Network Interface Module Kit from the DIN Rail	68
I/O Module Installation	69
Overview.....	69
Mounting a Module on a Base.....	70
Removing a Module from a Base.....	71
Mounting a Kit on the DIN Rail	71
Removing a Kit from the DIN Rail	73
Mounting a Terminal Block on a Module.....	74
Removing a Terminal Block from a Module.....	76
Mounting a Terminal Block on a PFB or PFD	78
Removing a Terminal Block from a PFB or PFD.....	79
Mounting a Cluster Termination on the DIN Rail.....	80

Removing a Cluster Termination from the DIN Rail	80
Equipment Removal	81
Complete Configuration Removal.....	81
Partial Configuration Removal	82
Coding the Modicon Edge I/O NTS	83
Overview.....	83
Creating a Coding Scheme.....	84
How to Install the Coding Keys.....	84
Labeling the Module	85
Plain Text Installation on Clear Cover	86
Maintaining and Diagnosing.....	87
Maintenance	88
Maintenance Plan	88
Diagnostics	89
Test Probes	89
Diagnostics Status LEDs	89
Modicon Edge I/O Configurator Software	89
Modicon Edge I/O Web Interface.....	90
Hot Swapping Electronic Modules.....	91
Overview.....	91
Hot Swapping Considerations.....	91
Elements That Cannot Be Hot Swapped	93
Hot Swap Procedure	93
Modules and Accessories.....	94
Power Supply Modules	95
NTSPFB1002H Power Supply Module, 24 Vdc, Field and Bus, Hardened	96
NTSPFB1002H Presentation	96
NTSPFB1002H Characteristics	99
NTSPFB1002H Wiring Diagram	100
NTSPFD1002H Power Supply Module, 24 Vdc, Field, Hardened	101
NTSPFD1002H Presentation	101
NTSPFD1002H Characteristics	104
NTSPFD1002H Wiring Diagram	105
Common Distribution Modules.....	107
NTSPCM0016H Common Distribution Module, 0 Vdc, 16 Points, Hardened	107
NTSPCM0016H Presentation	107
NTSPCM0016H Characteristics	110
NTSPCM0016H Wiring Diagram	112
NTSPCM0808H Common Distribution Module, 0 Vdc, 8 Points, 24 Vdc, 8 Points, eFuse, Hardened.....	113
NTSPCM0808H Presentation	113
NTSPCM0808H Characteristics	116
NTSPCM0808H Wiring Diagram	119
NTSPCM1600H Common Distribution Module, 24 Vdc, 16 Points, eFuse, Hardened.....	120
NTSPCM1600H Presentation	120
NTSPCM1600H Characteristics	123
NTSPCM1600H Wiring Diagram	126

- Spare Bases 128
 - Spare Bases Overview 128
 - Spare Bases NTSXBA•••0H..... 129
 - Spare Bases NTSXBA•••1H..... 130
 - Spare Bases NTSXBA•••3H..... 130
 - Spare Bases NTSXBA•••4H..... 131
- Terminal Blocks 132
 - Terminal Blocks Overview..... 132
 - Installing a Spare Clear Cover 134
 - Terminal Blocks for DC Input/Output Modules 135
 - Terminal Blocks for AC Input/Output Modules..... 138
 - Terminal Blocks for Power Supply Modules..... 140
- Dummy Modules 142
 - NTSDMY0100H Dummy Module, Single Slot, Hardened..... 142
 - NTSDMY0200H Dummy Module, Double Slot, Hardened 144
- Cluster Termination..... 148
- Appendices 150
 - Association Table 151
 - Current Consumption Tables for the Bus Power and 24 Vdc I/O Field
Power Segment..... 159
- Index 164

Safety Information

Important Information

Read these instructions carefully, and look at the equipment to become familiar with the device before trying to install, operate, service, or maintain it. The following special messages may appear throughout this documentation or on the equipment to warn of potential hazards or to call attention to information that clarifies or simplifies a procedure.



The addition of this symbol to a "Danger" or "Warning" safety label indicates that an electrical hazard exists which will result in personal injury if the instructions are not followed.



This is the safety alert symbol. It is used to alert you to potential personal injury hazards. Obey all safety messages that follow this symbol to avoid possible injury or death.

⚠ DANGER
DANGER indicates a hazardous situation which, if not avoided, will result in death or serious injury.

⚠ WARNING
WARNING indicates a hazardous situation which, if not avoided, could result in death or serious injury.

⚠ CAUTION
CAUTION indicates a hazardous situation which, if not avoided, could result in minor or moderate injury.

NOTICE
NOTICE is used to address practices not related to physical injury.

Please Note

Electrical equipment should be installed, operated, serviced, and maintained only by qualified personnel. No responsibility is assumed by Schneider Electric for any consequences arising out of the use of this material.

A qualified person is one who has skills and knowledge related to the construction and operation of electrical equipment and its installation, and has received safety training to recognize and avoid the hazards involved.

Before You Begin

Do not use this product on machinery lacking effective point-of-operation guarding. Lack of effective point-of-operation guarding on a machine can result in serious injury to the operator of that machine.

⚠ WARNING**UNGUARDED EQUIPMENT**

- Do not use this software and related automation equipment on equipment which does not have point-of-operation protection.
- Do not reach into machinery during operation.

Failure to follow these instructions can result in death, serious injury, or equipment damage.

This automation equipment and related software is used to control a variety of industrial processes. The type or model of automation equipment suitable for each application will vary depending on factors such as the control function required, degree of protection required, production methods, unusual conditions, government regulations, etc. In some applications, more than one processor may be required, as when backup redundancy is needed.

Only you, the user, machine builder or system integrator can be aware of all the conditions and factors present during setup, operation, and maintenance of the machine and, therefore, can determine the automation equipment and the related safeties and interlocks which can be properly used. When selecting automation and control equipment and related software for a particular application, you should refer to the applicable local and national standards and regulations. The National Safety Council's Accident Prevention Manual (nationally recognized in the United States of America) also provides much useful information.

In some applications, such as packaging machinery, additional operator protection such as point-of-operation guarding must be provided. This is necessary if the operator's hands and other parts of the body are free to enter the pinch points or other hazardous areas and serious injury can occur. Software products alone cannot protect an operator from injury. For this reason the software cannot be substituted for or take the place of point-of-operation protection.

Ensure that appropriate safeties and mechanical/electrical interlocks related to point-of-operation protection have been installed and are operational before placing the equipment into service. All interlocks and safeties related to point-of-operation protection must be coordinated with the related automation equipment and software programming.

NOTE: Coordination of safeties and mechanical/electrical interlocks for point-of-operation protection is outside the scope of the Function Block Library, System User Guide, or other implementation referenced in this documentation.

Start-up and Test

Before using electrical control and automation equipment for regular operation after installation, the system should be given a start-up test by qualified personnel to verify correct operation of the equipment. It is important that arrangements for such a check are made and that enough time is allowed to perform complete and satisfactory testing.

⚠ WARNING**EQUIPMENT OPERATION HAZARD**

- Verify that all installation and set up procedures have been completed.
- Before operational tests are performed, remove all blocks or other temporary holding means used for shipment from all component devices.
- Remove tools, meters, and debris from equipment.

Failure to follow these instructions can result in death, serious injury, or equipment damage.

Follow all start-up tests recommended in the equipment documentation. Store all equipment documentation for future references.

Software testing must be done in both simulated and real environments.

Verify that the completed system is free from all short circuits and temporary grounds that are not installed according to local regulations (according to the National Electrical Code in the U.S.A, for instance). If high-potential voltage testing is necessary, follow recommendations in equipment documentation to prevent accidental equipment damage.

Before energizing equipment:

- Remove tools, meters, and debris from equipment.
- Close the equipment enclosure door.
- Remove all temporary grounds from incoming power lines.
- Perform all start-up tests recommended by the manufacturer.

Operation and Adjustments

The following precautions are from the NEMA Standards Publication ICS 7.1-1995:

(In case of divergence or contradiction between any translation and the English original, the original text in the English language will prevail.)

- Regardless of the care exercised in the design and manufacture of equipment or in the selection and ratings of components, there are hazards that can be encountered if such equipment is improperly operated.
- It is sometimes possible to misadjust the equipment and thus produce unsatisfactory or unsafe operation. Always use the manufacturer's instructions as a guide for functional adjustments. Personnel who have access to these adjustments should be familiar with the equipment manufacturer's instructions and the machinery used with the electrical equipment.
- Only those operational adjustments required by the operator should be accessible to the operator. Access to other controls should be restricted to prevent unauthorized changes in operating characteristics.

About the Document

Document Scope

This guide describes the implementation of a Modicon Edge I/O system.

This guide contains:

- An overview and description of the Modicon Edge I/O system.
- Information and requirements to plan your installation.
- Installation procedure for your Modicon Edge I/O system.

Validity Note

The characteristics of the products described in this document are intended to match the characteristics that are available on www.se.com. As part of our corporate strategy for constant improvement, we may revise the content over time to enhance clarity and accuracy. If you see a difference between the characteristics in this document and the characteristics on www.se.com, consider www.se.com to contain the latest information.

Product Related Information

DANGER

HAZARD OF ELECTRIC SHOCK, EXPLOSION OR ARC FLASH

- Disconnect all power from all equipment including connected devices prior to removing any covers or doors, or installing or removing any accessories, hardware, cables, or wires except under the specific conditions specified in the appropriate hardware guide for this equipment.
- Always use a properly rated voltage sensing device to confirm the power is off where and when indicated.
- Replace and secure all covers, accessories, hardware, cables, and wires and confirm that a proper ground connection exists before applying power to the unit.
- Use only the specified voltage when operating this equipment and any associated products.

Failure to follow these instructions will result in death or serious injury.

▲ WARNING**LOSS OF CONTROL**

- Perform a Failure Mode and Effects Analysis (FMEA), or equivalent risk analysis, of your application, and apply preventive and detective controls before implementation.
- Provide a fallback state for undesired control events or sequences.
- Provide separate or redundant control paths wherever required.
- Supply appropriate parameters, particularly for limits.
- Review the implications of transmission delays and take actions to mitigate them.
- Review the implications of communication link interruptions and take actions to mitigate them.
- Provide independent paths for control functions (for example, emergency stop, over-limit conditions, and error conditions) according to your risk assessment, and applicable codes and regulations.
- Apply local accident prevention and safety regulations and guidelines.¹
- Test each implementation of a system for proper operation before placing it into service.

Failure to follow these instructions can result in death, serious injury, or equipment damage.

¹ For additional information, refer to NEMA ICS 1.1 (latest edition), "Safety Guidelines for the Application, Installation, and Maintenance of Solid State Control" and to NEMA ICS 7.1 (latest edition), "Safety Standards for Construction and Guide for Selection, Installation and Operation of Adjustable-Speed Drive Systems" or their equivalent governing your particular location.

▲ WARNING**UNINTENDED EQUIPMENT OPERATION**

- Only use software and hardware components approved by Schneider Electric for use with the system.
- Update your application program every time you change the physical hardware configuration.

Failure to follow these instructions can result in death, serious injury, or equipment damage.

General Cybersecurity Information

In recent years, the growing number of networked machines and production plants has seen a corresponding increase in the potential for cyber threats, such as unauthorized access, data breaches, and operational disruptions. You must, therefore, consider all possible cybersecurity measures to help protect assets and systems against such threats.

To help keep your Schneider Electric products secure and protected, it is in your best interest to implement the cybersecurity best practices as described in the [Cybersecurity Best Practices](#) document.

Schneider Electric provides additional information and assistance:

- [Subscribe to the Schneider Electric security newsletter.](#)
- [Visit the Cybersecurity Support Portal web page to:](#)
 - [Find Security Notifications.](#)
 - [Report vulnerabilities and incidents.](#)
- [Visit the Schneider Electric Cybersecurity and Data Protection Posture web page to:](#)
 - [Access the cybersecurity posture.](#)
 - [Learn more about cybersecurity in the cybersecurity academy.](#)
 - [Explore the cybersecurity services from Schneider Electric.](#)

Environmental Data

For product compliance and environmental information, refer to the [Schneider Electric Environmental Data Program](#).

Available Languages of the Document

The document is available in these languages:

- [English \(EIO0000004786\)](#)
- [French \(EIO0000004787\)](#)
- [Chinese \(EIO0000004791\)](#)

Related Documents

Title of documentation	Reference number
Modicon Edge I/O - Configurator and Web Interface - User Guide	EIO0000004810 (ENG)
	EIO0000004811 (FRE)
	EIO0000004815 (CHS)
Modicon Edge I/O - Software Integration and Compatibility - User Guide	EIO0000004818 (ENG)
	EIO0000004819 (FRE)
	EIO0000004823 (CHS)
Modicon Edge I/O - Diagnostic Data - User Guide	EIO0000004826 (ENG)
	EIO0000004827 (FRE)
	EIO0000004831 (CHS)

Title of documentation	Reference number
Modicon Edge I/O NTS - Network Interface Modules - User Guide	EIO0000004794 (ENG)
	EIO0000004795 (FRE)
	EIO0000004799 (CHS)
Modicon Edge I/O NTS - Discrete Modules - User Guide	EIO0000005238 (ENG)
	EIO0000005239 (FRE)
	EIO0000005243 (CHS)
Modicon Edge I/O NTS - Analog Modules - User Guide	EIO0000005246 (ENG)
	EIO0000005247 (FRE)
	EIO0000005251 (CHS)
Modicon Edge I/O NTS - Motion Expert Modules - User Guide	EIO0000005254 (ENG)
	EIO0000005255 (FRE)
	EIO0000005259 (CHS)
Modicon Edge I/O NTS - Counting Modules - User Guide	EIO0000005262 (ENG)
	EIO0000005263 (FRE)
	EIO0000005267 (CHS)
Modicon Edge I/O NTS - Field Device Master Modules - User Guide	EIO0000005270 (ENG)
	EIO0000005271 (FRE)
	EIO0000005275 (CHS)
Modicon Edge I/O NTS Range - Standards and Certifications	EIO0000005518 (ENG)
EcoStruxure Automation Device Maintenance	EIO0000004033 (ENG)
	EIO0000004048 (FRE)
	EIO0000004046 (GER)
	EIO0000004047 (SPA)
	EIO0000004049 (ITA)
	EIO0000004050 (CHS)
	EIO0000005090 (POR)
	EIO0000005089 (TUR)
Electrical Installation Guide	EIGED306001EN (ENG)

To find documents online, visit the Schneider Electric download center (www.se.com/ww/en/download/).

Information on Non-Inclusive or Insensitive Terminology

As a responsible, inclusive company, Schneider Electric is constantly updating its communications and products that contain non-inclusive or insensitive terminology. However, despite these efforts, our content may still contain terms that are deemed inappropriate by some customers.

Terminology Derived from Standards

The technical terms, terminology, symbols and the corresponding descriptions in the information contained herein, or that appear in or on the products themselves, are generally derived from the terms or definitions of international standards.

In the area of functional safety systems, drives and general automation, this may include, but is not limited to, terms such as *safety*, *safety function*, *safe state*, *fault*, *fault reset*, *malfunction*, *failure*, *error*, *error message*, *dangerous*, etc.

Among others, these standards include:

Standard	Description
IEC 61131-2:2007	Programmable controllers, part 2: Equipment requirements and tests.
ISO 13849-1:2023	Safety of machinery: Safety related parts of control systems. General principles for design.
EN 61496-1:2020	Safety of machinery: Electro-sensitive protective equipment. Part 1: General requirements and tests.
ISO 12100:2010	Safety of machinery - General principles for design - Risk assessment and risk reduction
EN 60204-1:2006	Safety of machinery - Electrical equipment of machines - Part 1: General requirements
ISO 14119:2013	Safety of machinery - Interlocking devices associated with guards - Principles for design and selection
ISO 13850:2015	Safety of machinery - Emergency stop - Principles for design
IEC 62061:2021	Safety of machinery - Functional safety of safety-related electrical, electronic, and electronic programmable control systems
IEC 61508-1:2010	Functional safety of electrical/electronic/programmable electronic safety-related systems: General requirements.
IEC 61508-2:2010	Functional safety of electrical/electronic/programmable electronic safety-related systems: Requirements for electrical/electronic/programmable electronic safety-related systems.
IEC 61508-3:2010	Functional safety of electrical/electronic/programmable electronic safety-related systems: Software requirements.
IEC 61784-3:2021	Industrial communication networks - Profiles - Part 3: Functional safety fieldbuses - General rules and profile definitions.
2006/42/EC	Machinery Directive
2014/30/EU	Electromagnetic Compatibility Directive
2014/35/EU	Low Voltage Directive

In addition, terms used in the present document may tangentially be used as they are derived from other standards such as:

Standard	Description
IEC 60034 series	Rotating electrical machines
IEC 61800 series	Adjustable speed electrical power drive systems
IEC 61158 series	Digital data communications for measurement and control – Fieldbus for use in industrial control systems

Finally, the term *zone of operation* may be used in conjunction with the description of specific hazards, and is defined as it is for a *hazard zone* or *danger zone* in the *Machinery Directive (2006/42/EC)* and *ISO 12100:2010*.

NOTE: The aforementioned standards may or may not apply to the specific products cited in the present documentation. For more information concerning the individual standards applicable to the products described herein, see the characteristics tables for those product references.

Introduction to the Modicon Edge I/O

What's in This Part

Modicon Edge I/O Overview 16
Modicon Edge I/O NTS Modules..... 25
Modicon Edge I/O NTS Accessories 34

Modicon Edge I/O Overview

What's in This Chapter

Modicon Edge I/O System.....	16
Modicon Edge I/O NTS Main Cluster.....	18
Modicon Edge I/O NTS Network Interface Module (NIM)	19
Modicon Edge I/O NTS Power Supply (PFB and PFD)	19
Modicon Edge I/O NTS Modules.....	20
Modicon Edge I/O NTS Accessories	21
Modicon Edge I/O Network Structure with Modbus TCP and EtherNet/IP	22
Modicon Edge I/O Network Structure with Sercos III.....	23

Modicon Edge I/O System

The Modicon Edge I/O is a range of products designed for expanding and customizing the I/O capacity according to the requirements of your application.

It supports open fieldbus standards for:

- EtherNet/IP
- Modbus TCP
- Sercos III

The Modicon Edge I/O NTS is an IP20-rated system and works with distributed I/O architectures.

The following illustration presents an example of the Modicon Edge I/O NTS distributed I/O connected to a fieldbus client:

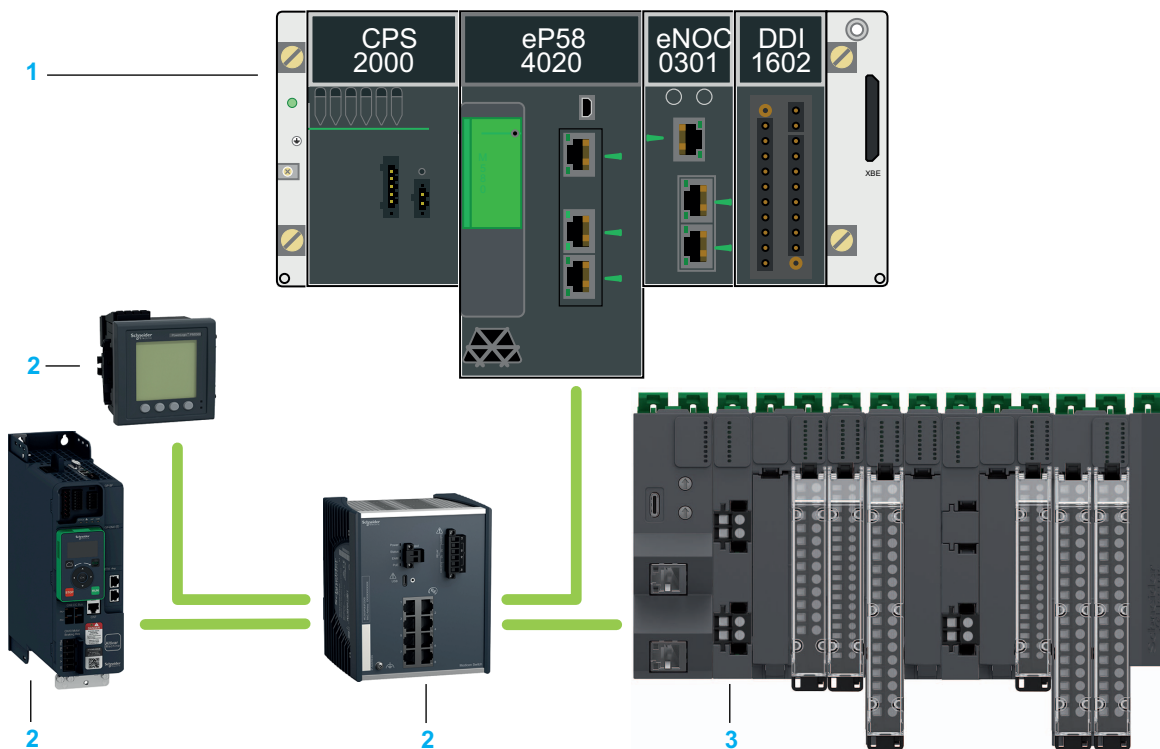

- 1: Controller
- 2: Other network devices
- 3: Main Cluster

The Modicon Edge I/O NTS slice is composed of a bus base, a module, and a terminal block as shown in this example:

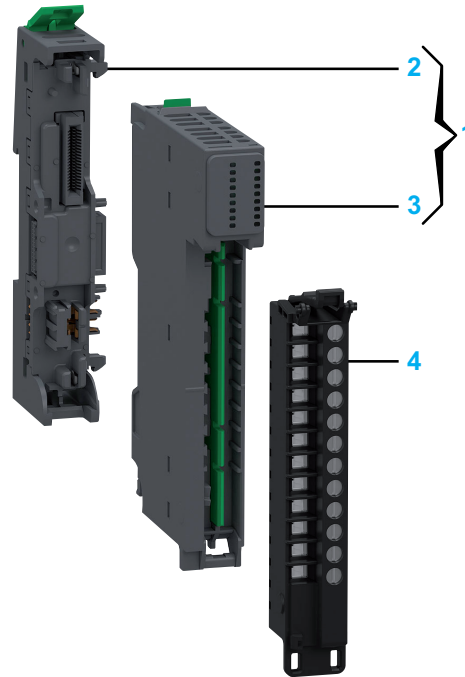

- 1: Modicon Edge I/O NTS kit
- 2: Base, page 128
- 3: Module, page 25
- 4: Terminal Block, page 132

NOTE: The bus base and the module can be purchased as a kit, and referred to as such throughout the present document. The compatible terminal block reference(s) are printed on the front side of the module.

Hardened Equipment

Hardened equipment is a ruggedized version of the non-hardened equipment. With conformal coating of the electronic boards, the hardened equipment can be used in many harsh chemical environments, and at extended temperatures $-40...+70\text{ }^{\circ}\text{C}$ ($-40...+158\text{ }^{\circ}\text{F}$).

NOTE: Temperature ratings are subject to derating under particular circumstances.

Hardened equipment references terminate with an 'H'.

Modicon Edge I/O NTS Main Cluster

The first cluster in a distributed I/O structure is called a main cluster and is composed with the following elements:

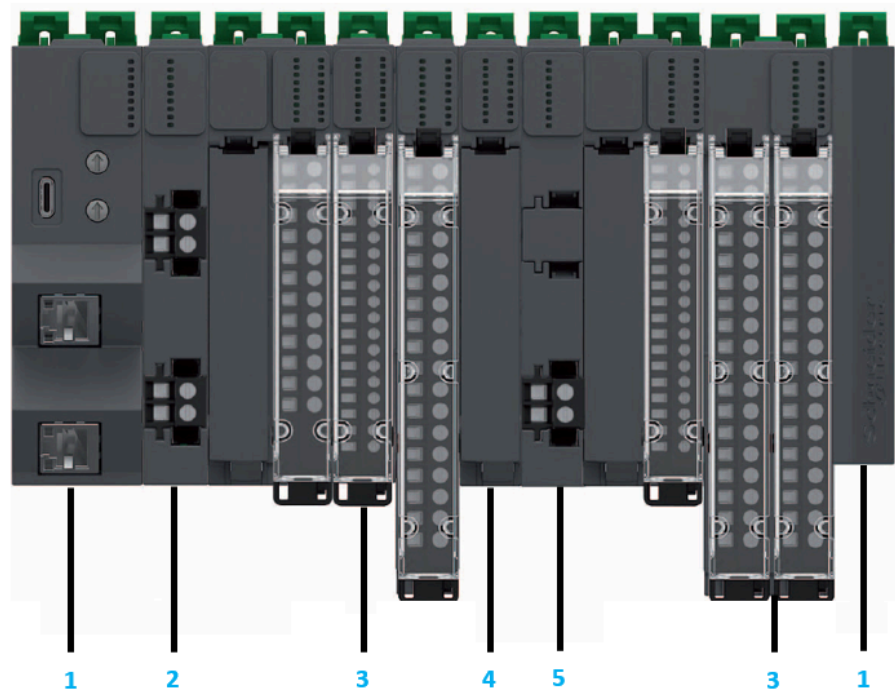

- 1: Network Interface Module and Spare Cluster Termination (mandatory)
- 2: Power supply Field and Bus module (mandatory)
- 3: Modicon Edge I/O NTS I/O modules
- 4: Accessories
- 5: Power supply Field Distribution module

On your main cluster:

- You can install up to 32 modules to the right of the Power supply Field and Bus module (Cluster termination excluded).
- The bandwidth usage of your installation is calculated when configuring the installation with your software. The maximum number of supported modules may be reduced for your use case.

Modicon Edge I/O NTS Network Interface Module (NIM)

The first component of a Modicon Edge I/O NTS distributed I/O main cluster is a network interface module, page 25.

This module serves as the interface between the I/O modules and the fieldbus client. It is the only module on the main cluster that is dependent on the fieldbus. There are various network interface modules available for each fieldbus.

NOTE: The Power supply Field and Bus module is required and must be positioned alongside the network interface module.

The following illustration shows the location of the network interface module in a distributed I/O main cluster:

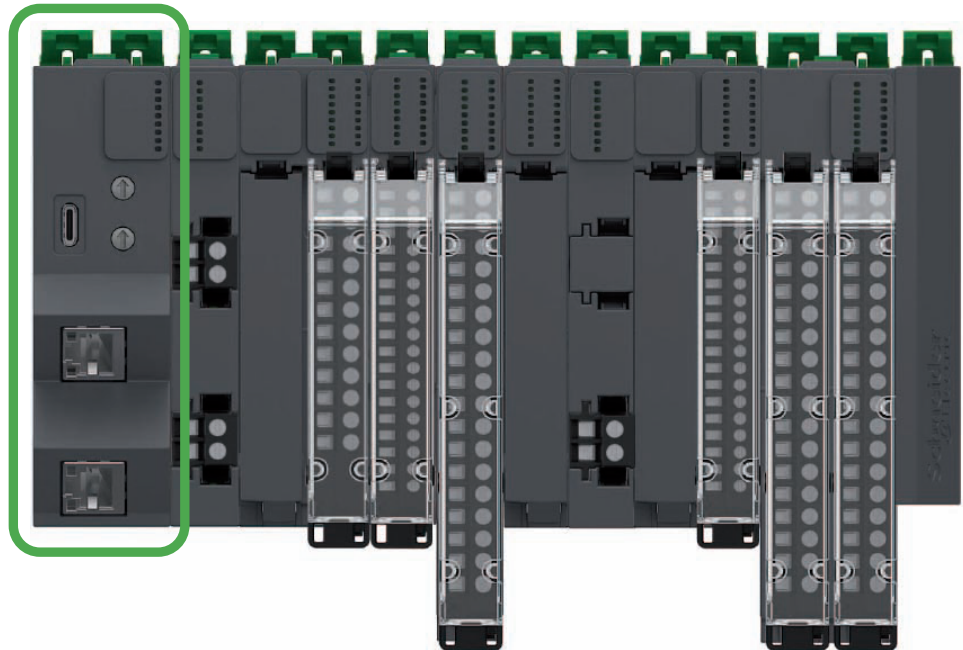

Modicon Edge I/O NTS Power Supply (PFB and PFD)

The second component of a Modicon Edge I/O cluster configuration is a Power supply Field and Bus (PFB), page 33.

The Power supply Field and Bus distributes power to:

- The network interface module
- The 24 Vdc bus
- The 24 Vdc field power

The Power supply Field Distribution (PFD), page 33 can be added to distribute the 24 Vdc over the 24 Vdc field power segment.

For more information on the Modicon Edge I/O NTS power distribution system, refer to Modicon Edge I/O NTS Power Distribution, page 46.

The following illustration shows a Power supply Field and Bus and a Power supply Field Distribution on a distributed I/O cluster:

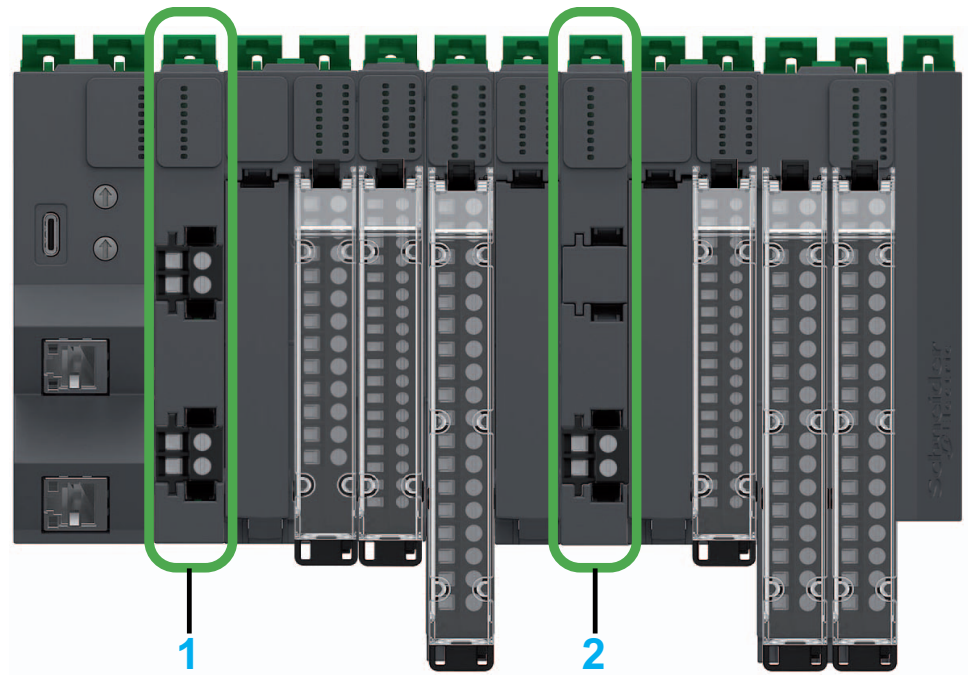

- 1: Power supply Field and Bus
2: Power supply Field Distribution

Modicon Edge I/O NTS Modules

The following illustration shows the Modicon Edge I/O NTS I/O modules on a distributed I/O cluster:



The range of Modicon Edge I/O NTS modules includes:

- Discrete modules, classified as:
 - Input modules, page 25
 - Output modules, page 26

- Analog modules, classified as:
 - Input modules, page 28
 - Output modules, page 29
 - Mixed input/output modules, page 30
- Counting modules, classified as:
 - Input modules, page 30
 - Mixed input/output modules, page 31
- Motion Expert modules, page 32
- Field Device Master modules, page 33
- Power Supply Modules, page 95
- Common Distribution Modules, page 33
- Dummy Modules, page 142

Modicon Edge I/O NTS Accessories

The following illustration shows an example of Modicon Edge I/O NTS accessories on a distributed I/O cluster:

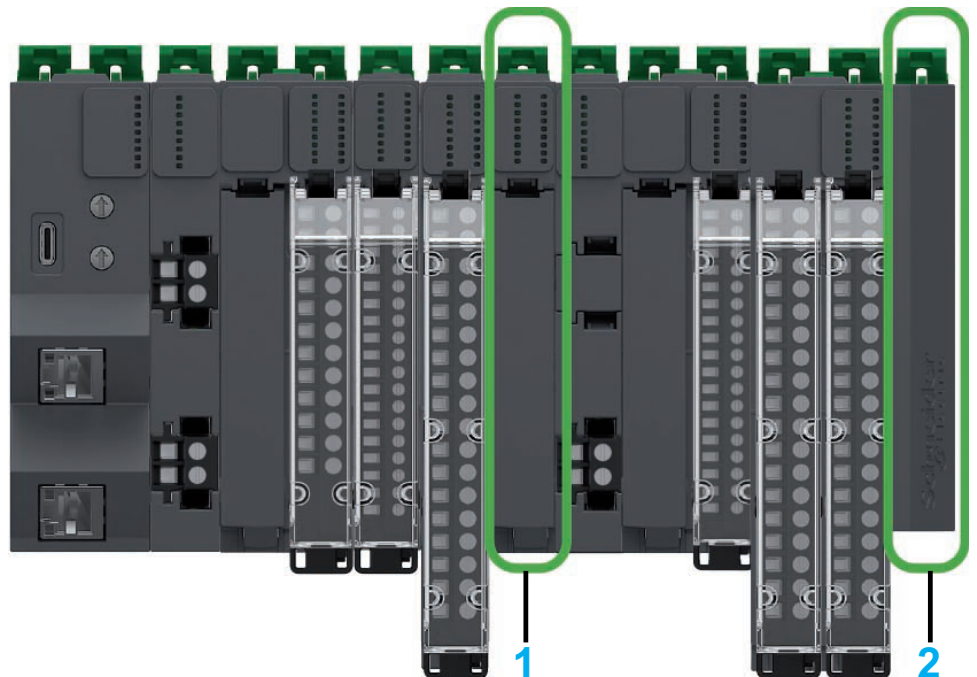

- 1: Dummy module
2: Cluster termination

The range of Modicon Edge I/O NTS accessories includes:

- Spare bases, page 35
- Spare cluster termination, page 35 (mandatory)
- Terminal blocks, page 132
- Spare cover for terminal block, page 35
- Other Accessories (Labels, coding keys, DIN Rail end stoppers), page 34

Modicon Edge I/O Network Structure with Modbus TCP and EtherNet/IP

The Modicon Edge I/O system supports the following distributed I/O network topologies:

- Line topology
- Star topology
- Ring topology

The following illustration shows the line and star network topologies with several Modicon Edge I/O NTS main clusters:

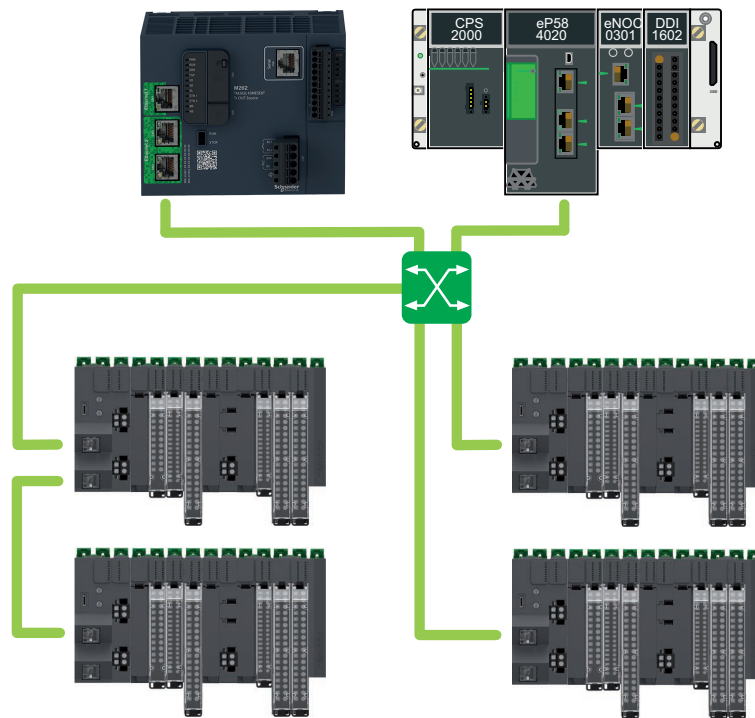

The following illustration shows an RSTP ring network topology with an M262 controller and several Modicon Edge I/O NTS main clusters:

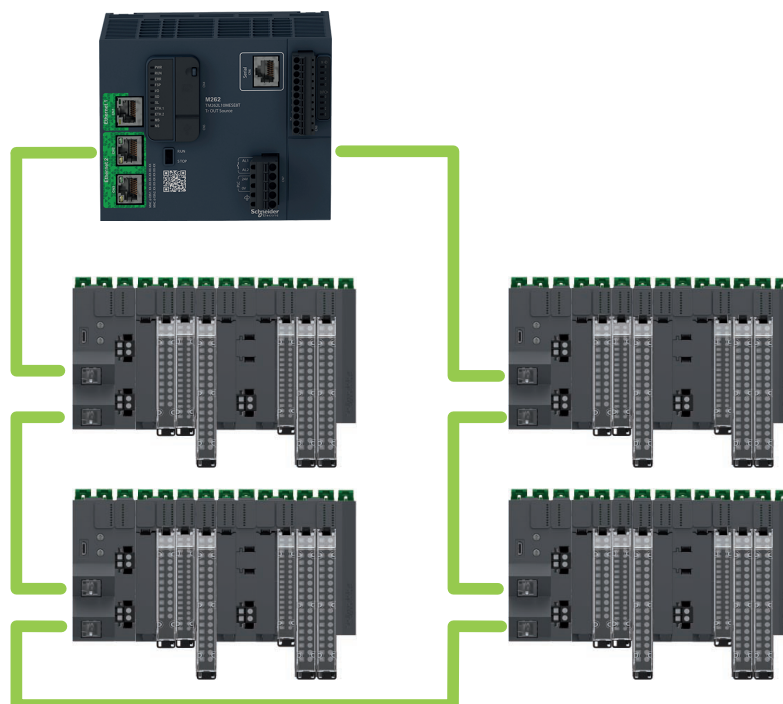

The following illustration shows an RSTP ring network topology with an M580 controller and several Modicon Edge I/O NTS main clusters:

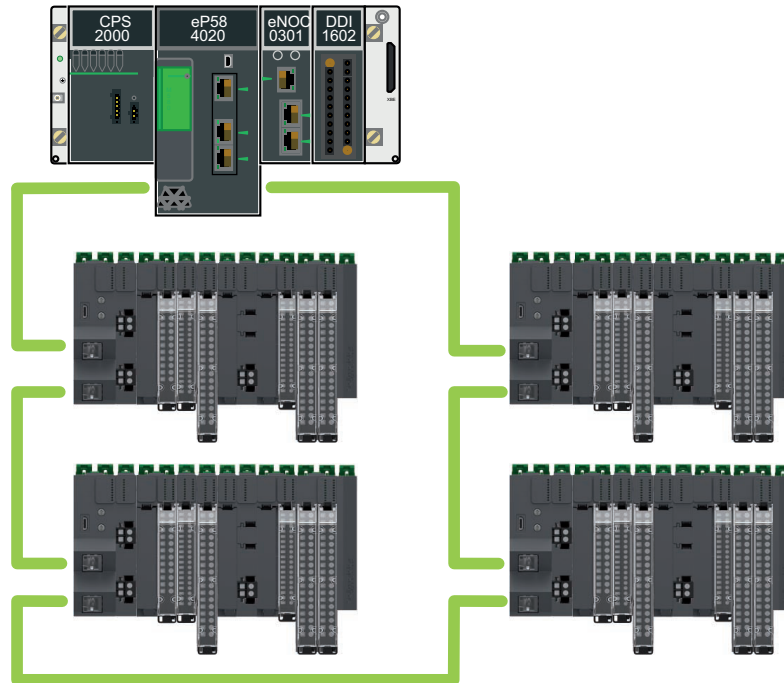

The following illustration shows an RSTP ring network topology with M580 redundant controllers and several Modicon Edge I/O NTS main clusters:

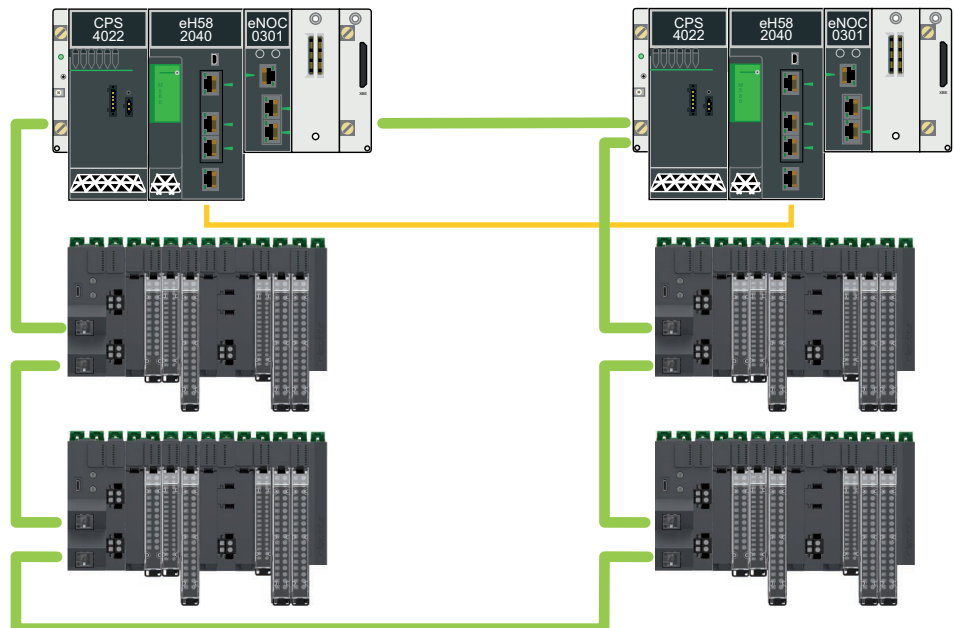

NOTE: RSTP service is enabled by default. All nodes of an RSTP ring must support RSTP and must have RSTP service enabled.

Modicon Edge I/O Network Structure with Sercos III

The Modicon Edge I/O system supports the following distributed I/O network topologies:

- Line topology
- Ring topology

The following illustration shows the line network topology with an M262 controller and several Modicon Edge I/O NTS main clusters:

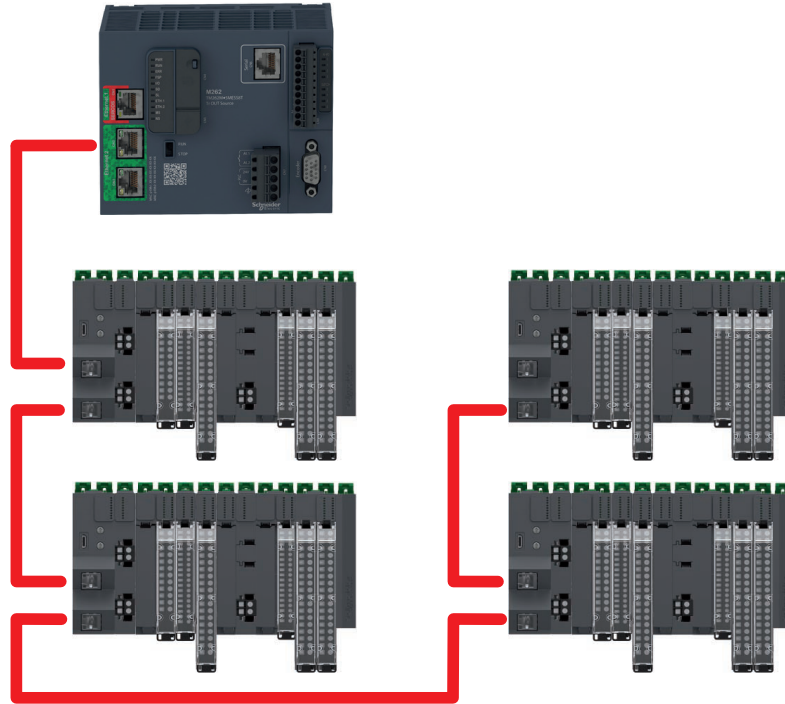

The following illustration shows a ring network topology with a PacDrive LMC Pro/Pro2 controller and several Modicon Edge I/O NTS main clusters:

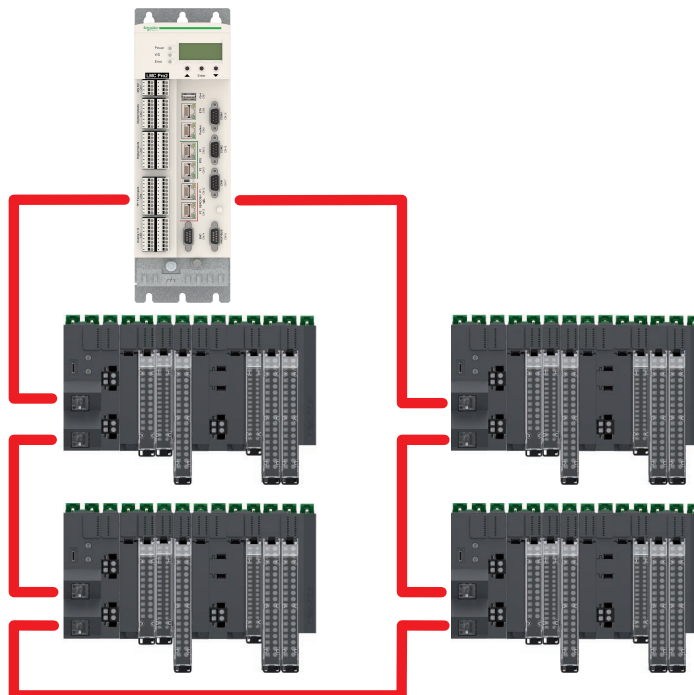

Modicon Edge I/O NTS Modules

What's in This Chapter

- Network Interface Modules..... 25
- Discrete Input Modules 25
- Discrete Output Modules..... 26
- Analog Input Modules 28
- Analog Output Modules 29
- Analog Mixed Input/Output Modules 30
- Counting Input Modules 30
- Counting Input/Output Modules 31
- Motion Expert Modules 32
- Field Device Master Modules 33
- Power Supply Modules 33
- Common Distribution Modules..... 33
- Dummy Module..... 33

Network Interface Modules

The following table shows the network interface modules:

Reference	Port	Communication protocol	Connection type
NTSNEC1200 / NTSNEC1200H	2 isolated switched Ethernet ports	EtherNet/IP Modbus TCP	RJ45
	1 USB port	USB 2.0	USB Type-C
NTSNSC1200	2 isolated switched Sercos ports	Sercos III	RJ45
	1 USB port	USB 2.0	USB Type-C

For more information on these modules, refer to the Modicon Edge I/O NTS - Network Interface Modules - User Guide.

Discrete Input Modules

The following table shows the discrete input modules:

Reference	Number of Channels	Channel Type	Voltage	Terminal Type / Pitch
NTSDDI0402 / NTSDDI0402H	4	Sink inputs with diagnostics	24 Vdc	Removable screw/spring terminal block / 5 mm
NTSDDI0602	6	Sink inputs	24 Vdc	Removable screw/spring terminal block / 3.81 mm
NTSDDI0802X	8	Sink inputs	24 Vdc	Removable screw/spring terminal block / 5 mm
NTSDDI1602	16	Sink inputs	24 Vdc	Removable screw/spring terminal block / 3.81 mm
NTSDDI1602X / NTSDDI1602XH	16	Sink inputs	24 Vdc	Removable screw/spring terminal block / 5 mm
NTSDDI1642	16	Source inputs	24 Vdc	Removable screw/spring terminal block / 3.81 mm
NTSDAI0215H	2	Isolated inputs	100...240 Vac	Removable screw/spring terminal block / 5 mm
NTSDAI0403H	4	Inputs	24...48 Vac 48 Vdc	Removable screw/spring terminal block / 5 mm
NTSDAI0404H	4	Inputs	100...120 Vac	Removable screw/spring terminal block / 5 mm
NTSDAI0804	8	Inputs	100...120 Vac	Removable screw/spring terminal block / 5 mm

For more information on these modules, refer to the Modicon Edge I/O NTS - Discrete Modules - User Guide.

Discrete Output Modules

The following table shows the discrete output modules:

Reference	Number of Channels	Channel Type	Voltage Current	Terminal Type / Pitch
NTSDDO0212H	2	Isolated source outputs	24 Vdc 2 A / channel	Removable screw/spring terminal block / 5 mm
NTSDDO0402 / NTSDDO0402H	4	Source outputs with diagnostic	24 Vdc 500 mA / channel	Removable screw/spring terminal block / 5 mm
NTSDDO0602	6	Source outputs	24 Vdc 500 mA / channel	Removable screw/spring terminal block / 3.81 mm
NTSDDO0802	8	Source outputs	24 Vdc, external supply 2 A / channel, 8 A / module	Removable screw/spring terminal block / 5 mm
NTSDDO0802X	8	Source outputs	24 Vdc 500 mA / channel	Removable screw/spring terminal block / 5 mm
NTSDDO1602	16	Source outputs	24 Vdc 500 mA / channel	Removable screw/spring terminal block / 3.81 mm
NTSDDO1602X / NTSDDO1602XH	16	Source outputs	24 Vdc 500 mA / channel, 4 A / module	Removable screw/spring terminal block / 5 mm
NTSDDO1602XA / NTSDDO1602XAH	16	Source outputs	24 Vdc, external supply 500 mA / channel, 8 A / module	Removable screw/spring terminal block / 5 mm
NTSDAO0205	2	Triac outputs	100...240 Vac 1 A / channel, 2 A / module with derating	Removable screw/spring terminal block / 5 mm
NTSDAO0415 / NTSDAO0415H	4	Isolated triac outputs	100...240 Vac 2 A / channel, 8 A / module with derating	Removable screw/spring terminal block / 5 mm
NTSDRC0215	2	Isolated changeover relay outputs	5...125 Vdc 24...250 Vac 2 A / channel	Removable screw/spring terminal block / 5 mm
NTSDRC0415 / NTSDRC0415H	4	Isolated changeover relay outputs	5...125 Vdc 24...250 Vac 5 A / channel, 20 A / module with derating	Removable screw/spring terminal block / 5 mm
NTSDRA0615	6	Isolated normally open relay outputs	5...125 Vdc 24...240 Vac 2 A / channel	Removable screw/spring terminal block / 5 mm

For more information on these modules, refer to the Modicon Edge I/O NTS - Discrete Modules - User Guide.

Analog Input Modules

The following table shows the analog input modules:

Reference	Number of Channels	Channel Type	Accuracy at 25 °C (77 °F)	Mode	Terminal Type / Pitch
NTSAMI0210 / NTSAMI0210H	2	Isolated inputs with loop power	0.05 %	± 10 Vdc 0...10 Vdc ± 5 Vdc 0...5 Vdc 1...5 Vdc ± 20 mA 0...20 mA 4...20 mA	Removable screw/spring terminal block / 5 mm
NTSAMI0400	4	Inputs	0.3 %	± 10 Vdc 0...10 Vdc ± 5 Vdc 0...5 Vdc 1...5 Vdc ± 20 mA 0...20 mA 4...20 mA	Removable screw/spring terminal block / 5 mm
NTSAMI0420	4	Differential inputs	0.3 %	± 10 Vdc 0...10 Vdc ± 5 Vdc 0...5 Vdc 1...5 Vdc ± 20 mA 0...20 mA 4...20 mA	Removable screw/spring terminal block / 5 mm
NTSAMI0800	8	Inputs	0.3 %	± 10 Vdc 0...10 Vdc ± 5 Vdc 0...5 Vdc 1...5 Vdc ± 20 mA 0...20 mA 4...20 mA	Removable screw/spring terminal block / 3.81 mm
NTSACI0802X / NTSACI0802XH	8	Inputs with loop power	0.1 %	± 20 mA 0...20 mA 4...20 mA	Removable screw/spring terminal block / 5 mm
NTSAHI0412XH	4	Isolated HART inputs with loop power	0.05 %	4...20 mA	Removable screw/spring terminal block / 5 mm
NTSART0214 / NTSART0214H	2	Isolated inputs	0.05 %	RTD Thermocouple Voltage	Removable screw/spring terminal block / 5 mm

Reference	Number of Channels	Channel Type	Accuracy at 25 °C (77 °F)	Mode	Terminal Type / Pitch
NTSART0404	4	Differential inputs	0.05 %	RTD Thermocouple Voltage	Removable screw/spring terminal block / 5 mm
NTSART0404XH	4	Differential inputs	0.05 %	RTD Thermocouple Voltage	Removable screw/spring terminal block / 5 mm
NTSART0603	6	Differential inputs	0.05 %	RTD Thermistor	Removable screw/spring terminal block / 3.81 mm

For more information about these modules, refer to Modicon Edge I/O NTS - Analog Modules - User Guide.

Analog Output Modules

The following table shows the analog output modules:

Reference	Number of Channels	Channel Type	Accuracy at 25 °C (77 °F)	Mode	Terminal Type / Pitch
NTSAHO0212H	2	Isolated HART outputs	0.1 %	4...20 mA	Removable screw/spring terminal block / 5 mm
NTSAMO0210 / NTSAMO0210H	2	Isolated outputs	0.1 %	± 10 Vdc 0...10 Vdc ± 5 Vdc 0...5 Vdc 1...5 Vdc ± 20 mA 0...20 mA 4...20 mA	Removable screw/spring terminal block / 5 mm
NTSAMO0400 / NTSAMO0400H	4	Outputs	0.1 %	± 10 Vdc 0...10 Vdc ± 5 Vdc 0...5 Vdc 1...5 Vdc 0...20 mA 4...20 mA	Removable screw/spring terminal block / 5 mm

For more information about these modules, refer to Modicon Edge I/O NTS - Analog Modules - User Guide.

Analog Mixed Input/Output Modules

The following table shows the analog mixed input and output modules.

Reference	Number of Channels	Channel Type	Accuracy at 25 °C (77 °F)	Mode	Terminal Type / Pitch
NTSAMM0600	4 2	Isolated input group Isolated output group	0.3 %	± 10 Vdc 0...10 Vdc ± 5 Vdc 0...5 Vdc 1...5 Vdc ± 20 mA 0...20 mA 4...20 mA	Removable screw/spring terminal block / 3.81 mm

For more information about these modules, refer to Modicon Edge I/O NTS - Analog Modules - User Guide.

Counting Input Modules

The following table shows the high-speed counter input modules:

Reference	Number of Channels	Expert Function	Discrete Inputs	Discrete Outputs	Voltage	Terminal Type / Pitch
NTSEHC0100	1	Simple counting Frequency meter Period meter Ratio meter Single phase counting Single phase event counting Dual phase counting	6	-	24 Vdc	Removable screw/spring terminal block / 5 mm

For more information about these modules, refer to Modicon Edge I/O NTS - Counting Modules - User Guide.

Counting Input/Output Modules

The following table shows the high speed-counter input and output modules:

Reference	Number of Channels	Expert Function	Discrete Inputs	Discrete Outputs	Voltage	Terminal Type / Pitch
NTSEHC0120H	1	Simple counting Frequency meter Period meter Ratio meter Single phase counting Single phase event counting Dual phase counting PWM output Reflex output sub-function	6	4	24 Vdc	Removable screw/spring terminal block / 5 mm
NTSEHC0220	2	Simple counting Frequency meter Period meter Ratio meter Single phase counting Single phase event counting Dual phase counting PWM output Reflex output sub-function	12	8	24 Vdc	Removable screw/spring terminal block / 3.81 mm

For more information about these modules, refer to Modicon Edge I/O NTS - Counting Modules - User Guide.

Motion Expert Modules

The following table shows the motion expert modules:

Reference	Number of Channels	Expert Function	Discrete Inputs	Discrete Outputs	Signal type	Terminal Type/Pitch
NTSEHE0221	2	Incremental SSI BiSS-C Preset sub-function Capture sub-function Reflex output sub-function	4	8	RS-422 Encoder Input	Removable screw/spring terminal block / 3.81 mm
NTSEME0101	1	Incremental SSI BiSS-C Preset sub-function Capture sub-function	2	-	RS-422 Encoder Input	Removable screw/spring terminal block / 3.81 mm
NTSEME0102	1	SinCos EndDat Hiperface	2	-	RS-422 Encoder Input 1 Vpp	Removable screw/spring terminal block / 3.81 mm
NTSECS0121	1	Incremental SSI BiSS-C CAM sub-function Preset sub-function Capture sub-function	2	8	RS-422 Encoder Input	Removable screw/spring terminal block / 3.81 mm
NTSEME0110 ⁽¹⁾	1	Output encoder	2	-	RS-422 Encoder Output	Removable screw/spring terminal block / 3.81 mm
NTSEDT0800 ⁽¹⁾	8	Timestamped discrete input	8	-	24 Vdc	Removable screw/spring terminal block / 3.81 mm
NTSEDT0810 ⁽¹⁾	8	Timestamped discrete output	-	8	24 Vdc	Removable screw/spring terminal block / 3.81 mm
NTSEDO0810 ⁽¹⁾	8	Oversampled discrete output	-	8	24 Vdc	Removable screw/spring terminal block / 3.81 mm
NTSEDM0822 ⁽¹⁾	8	Output pulse after input event Oversampled discrete input Timestamped discrete input Oversampled discrete output Timestamped discrete output	4	4	24 Vdc	Removable screw/spring terminal block / 3.81 mm
NTSEMP0220	2	PTO PWM Frequency Generator	8	2	RS-422 pulse output	Removable screw/spring terminal block / 3.81 mm

⁽¹⁾ These modules must be used with a network interface module using the Sercos III communication protocol.

For more information about these modules, refer to Modicon Edge I/O NTS - Motion Expert Modules - User Guide.

Field Device Master Modules

The following table shows the Field Device Master modules:

Reference	Number of Channels	Function	Wiring	Terminal Type / Pitch
NTSFMB0120 / NTSFMB0120H ⁽¹⁾	1	Modbus RTU Modbus ASCII ASCII	RS-422/RS-485: 2-wire or 4-wire	Removable screw/spring terminal block / 5 mm
NTSFIO0400 ⁽¹⁾	Up to 4	IO-Link Master	Class A: 3-wire or 4-wire	Removable screw/spring terminal block / 3.81 mm

⁽¹⁾ These modules cannot be used with a network interface module using the Sercos III communication protocol.

For more information about these modules, refer to Modicon Edge I/O NTS - Field Device Master Modules - User Guide.

Power Supply Modules

The following table shows the power supply modules:

Reference	Voltage	Function	Terminal Type / Pitch
NTSPFB1002H, page 96	24 Vdc	Field and Bus power supply	Removable screw/spring terminal block / 5 mm
NTSPFD1002H, page 101	24 Vdc	Field power supply	Removable screw/spring terminal block / 5 mm

Common Distribution Modules

The following table shows the common distribution modules:

Reference	Function	Terminal Type / Pitch
NTSPCM0016H, page 107	0 Vdc connection points: 16	Removable screw/spring terminal block / 3.81 mm
NTSPCM0808H, page 113	0 Vdc connection points: 8 24 Vdc connection points: 8	Removable screw/spring terminal block / 3.81 mm
NTSPCM1600H, page 120	24 Vdc connection points: 16	Removable screw/spring terminal block / 3.81 mm

Dummy Module

The following table shows the dummy module reference:

Reference	Function	Terminal Type / Pitch
NTSDMY0100H, page 142	Dummy Module, Single Slot, Hardened	-
NTSDMY0200H, page 144	Dummy Module, Double Slot, Hardened	-

Modicon Edge I/O NTS Accessories

What's in This Chapter

Spare Bases	35
Spare Cluster Termination.....	35
Spare Cover for Terminal Block	35
Other Accessories	35

Spare Bases

The following table shows the spare bases references:

Reference	Description
NTSXBA0100H, page 129	Spare Base, 1 Slot, for Input/Output Common or Expert Module, Hardened
NTSXBA0103H, page 130	Spare Base, 1 Slot, for Power Supply Field and Bus Module, Hardened
NTSXBA0104H, page 131	Spare Base, 1 Slot, for Power Supply Field Distribution Module, Hardened
NTSXBA0200H, page 129	Spare Base, 2 Slots, for Input/Output Common/Expert/Safety Module, Hardened
NTSXBA0201H, page 130	Spare Base, 2 Slots, for Network Interface or Bus Extender Module, Hardened
NTSXBA0301H, page 130	Spare Base, 3 Slots, for Network Interface Module, Hardened

Spare Cluster Termination

The following table shows the spare cluster termination reference:

Reference	Description
NTSXMP0000H, page 148	Spare Cluster Termination, Hardened

Spare Cover for Terminal Block

The following table shows the spare cover for terminal block references:

Reference	Description
NTSXEM0000H, page 134	Spare Cover for Terminal Block, for 12 Points 5 mm or 18 points 3,81 mm Terminal Blocks, Hardened
NTSXEM0000XH, page 134	Spare Cover for Terminal Block, for 18 Points 5 mm Pitch Terminal Blocks, Hardened

Other Accessories

The following table shows other Modicon Edge I/O NTS accessory references:

Reference	Description	Use
NTSXMP1000	Accessory, Wheel of 8 Flexible Coding Keys, Set of 10 units	Coding keys are used to create a coding scheme which can help minimize mounting and maintenance errors. For more information, refer to Coding the Modicon Edge I/O NTS, page 83.
NTSXMP2000	Accessory, Label 14 x 10 mm, to be fixed on Top of Module, Set of 50 units	Marking labels can help you identify information on individual modules. For more information, refer to Labeling the Module, page 85.
NSYTRAABV35	Accessory, DIN Rail End Stoppers, Set of 50 units	Helps secure the network interface module and modules on a top hat section rail (DIN rail). For more information, refer to DIN Rail End Stoppers, page 65.

Initial Planning Considerations

What's in This Part

Operating Environment.....	37
Certifications and Standards	40
Mechanical Requirements	41
Modicon Edge I/O NTS Power Distribution	46
Electrical Requirements	49
Grounding the system.....	54

Operating Environment

What's in This Chapter

Introduction..... 37
 Enclosure Requirements..... 37
 Environmental Characteristics 37
 Electromagnetic Susceptibility 39

Introduction

The following information describes the system-wide environmental requirements and characteristics for the Modicon Edge I/O system.

Enclosure Requirements

The Modicon Edge I/O NTS modules are designed as Class A, Group 1 industrial equipment according to IEC/CISPR Publication 11. If they are used in environments other than those described in the standard, or in environments that do not meet the specifications in this manual, your ability to meet electromagnetic compatibility requirements in the presence of conducted and/or radiated interference may be reduced.

The Modicon Edge I/O NTS modules meet European Community (CE) requirements for open equipment as defined by EN61131-2. You must install them in an enclosure designed for the specific environmental conditions and to minimize the possibility of unintended contact with hazardous voltages. Your enclosure should be constructed of metal to improve the electromagnetic immunity of your Modicon Edge I/O system. Your enclosure should have a keyed locking mechanism to minimize unauthorized access.

Environmental Characteristics

This equipment meets CE requirements as indicated in the table below. It is intended for use in a Pollution Degree 2 industrial environment and is intended for indoor use only. Over voltages of the supply mains is limited to overvoltage category II.

▲ WARNING
UNINTENDED EQUIPMENT OPERATION
Do not exceed any of the rated values specified in the environmental and electrical characteristics tables.
Failure to follow these instructions can result in death, serious injury, or equipment damage.

The following table shows the general environmental characteristics:

Environmental Characteristic	Standard equipment	Hardened equipment
Ambient operating temperature (according to IEC/EN 61010-2-201)	Horizontal installation on a vertical plane: -30...60 °C (-22...140 °F)	Horizontal installation on a vertical plane: -40...70 °C (-40...158 °F)
	Vertical installation on a vertical plane or installation on a horizontal plane: -30...55 °C (-22...131 °F)	Vertical installation on a vertical plane or installation on a horizontal plane: -40...60 °C (-40...140 °F)
Ambient storage temperature (according to IEC/EN 61010-2-201)	-40...85 °C (-40...158 °F)	
Relative humidity (without condensation) Damp heat, cyclic (cyclical humidity)	5...95 % at 55 °C (131 °F)	
Relative humidity (without condensation) Damp heat, steady state (continuous humidity)	5...93 % at 55 °C (131 °F)	5...93 % at 60 °C (140 °F)
Operating altitude	0...2,000 m (0...6,560 ft) without derating factor ⁽¹⁾ For higher altitude, refer to section Altitude, page 38.	
Vibration resistance (according to IEC/EN 61131-2)	3.5 mm (0.13 in) fixed amplitude from 5...8.4 Hz 9.8 m/s ² (32.15 ft/s ²) (1 g ⁿ) fixed acceleration from 8.4...150 Hz	
Mechanical shock resistance (according to IEC/EN 61131-2)	147 m/s ² or 482.28 ft/s ² (15 g ⁿ) for a duration of 11 ms, 3 shocks/direction/axis.	
<p>NOTE: The tested ranges may indicate values beyond that of the IEC Standard. In all cases, the system meets the minimum specification if indicated.</p> <p>⁽¹⁾ The Modicon Edge I/O NTS modules are designed to operate with rated characteristics (current, power) at altitudes up to 2,000 m (6,560 ft). An additional derating applies to modules that operate above 2,000 m (6,560 ft) altitude.</p>		

Altitude

The Modicon Edge I/O NTS modules are designed to operate with rated characteristics (current, power) at altitudes up to 2,000 m (6,562 ft).

The following table presents the maximum operating altitude with application of the multiplication factor on design according to IEC 61010-2-201 Table 6 (Electrical Safety Rules):

Module range	Maximum installation altitude
NTSDA***, NTSDR***	3,000 m (9,843 ft)
NTSDDD***, NTSA***, NTSEHC***, NTSN***, NTSF***, NTSPF***, NTSDMY***, NTSPCM***	5,000 m (16,404 ft)

A derating applies on the maximum operating ambient temperature for modules that operate above 2,000 m (6,562 ft) altitude according to IEC 61131-2.

Conservation of Outputs Capabilities

The following table presents the maximum operating temperature with application of the multiplication factor on design according to IEC 61131-2 Table A.1 and Table A.2 (Component temperature derating with altitude).

The module characteristics, such as rated current and power, remain unchanged if the maximum operating ambient temperature does not exceed these values:

Altitude	Maximum operating ambient temperature					
	Standard module			Hardened module		
	Vertical plane		Horizontal plane	Vertical plane		Horizontal plane
	Horizontal installation ⁽¹⁾	Vertical installation ⁽¹⁾	Horizontal or vertical installation ⁽¹⁾	Horizontal installation ⁽¹⁾	Vertical installation ⁽¹⁾	Horizontal or vertical installation ⁽¹⁾
0...2,000 m (0...6,562 ft)	60 °C (140 °F)	55 °C (131 °F)		70 °C (158 °F)	60 °C (140 °F)	
3,000 m (9,843 ft)	54 °C (129.2 °F)	49.5 °C (121.1 °F)		63 °C (145.4 °F)	54 °C (129.2 °F)	
4,000 m (13,123 ft)	48 °C (118.4 °F)	44 °C (111.2 °F)		56 °C (132.8 °F)	48 °C (118.4 °F)	
5,000 m (16,404 ft)	42 °C (107.6 °F)	38.5 °C (101.3 °F)		49 °C (120.2 °F)	42 °C (107.6 °F)	

NOTE: Values for intermediate altitudes may be derived by linear interpolation.
⁽¹⁾ Refer to Mounting Positions, page 43.

Electromagnetic Susceptibility

The extension module components and the network interface module meet electromagnetic susceptibility specifications as indicated in the Modicon Edge I/O NTS Range - Standards and Certifications.

Certifications and Standards

For information on certifications and conformance to standards, go to www.se.com.

For information on certifications and standards of the Modicon Edge I/O NTS, refer to the Modicon Edge I/O NTS Range - Standards and Certifications.

For product compliance and environmental information, refer to the Schneider Electric Environmental Data Program.

Mechanical Requirements

What's in This Chapter

Enclosing the Modicon Edge I/O NTS41
 Clearance Requirements41
 Thermal Considerations.....42
 Mounting Positions43

Enclosing the Modicon Edge I/O NTS

These components have an IP20 rating and must be enclosed.

Components of the Modicon Edge I/O NTS system are mounted side by side. There is no space between components.

Maintain clearance requirements between your system (installed in the enclosure) and surrounding fixed objects (such as wire ducts and inside surfaces of the enclosure); for more information, refer to *Clearance Requirements*, page 41.

For more information about the dimensions of each module, refer to their respective user guides.

NOTE: The overall size of the enclosure is determined by the number of extension modules that are used in the main cluster and any other auxiliary equipment.

Clearance Requirements

You must provide adequate clearance for adequate ventilation and to maintain an ambient temperature as described in the *environmental characteristics*, page 37.

Provide the following clearance requirements when installing the equipment:

- Clearance requirements between the Modicon Edge I/O NTS system and all sides of the cabinet (including the panel door).
- Clearance requirements between the terminal blocks and the wiring ducts to avoid effects of electromagnetic interference.
- Clearance requirements between the Modicon Edge I/O NTS system and other heat-generating devices installed in the same cabinet.

▲ WARNING
<p>UNINTENDED EQUIPMENT OPERATION</p> <ul style="list-style-type: none"> • Place devices dissipating the most heat at the top of the cabinet and ensure adequate ventilation. • Do not place this equipment next to or above devices that might cause overheating. • Install the equipment in a location with the minimum clearance from all adjacent structures and equipment as directed in the present document. • Install all equipment in accordance with the specifications in the related documentation. <p>Failure to follow these instructions can result in death, serious injury, or equipment damage.</p>

The following illustration presents the minimum clearances requirements for a Modicon Edge I/O NTS system in a cabinet:

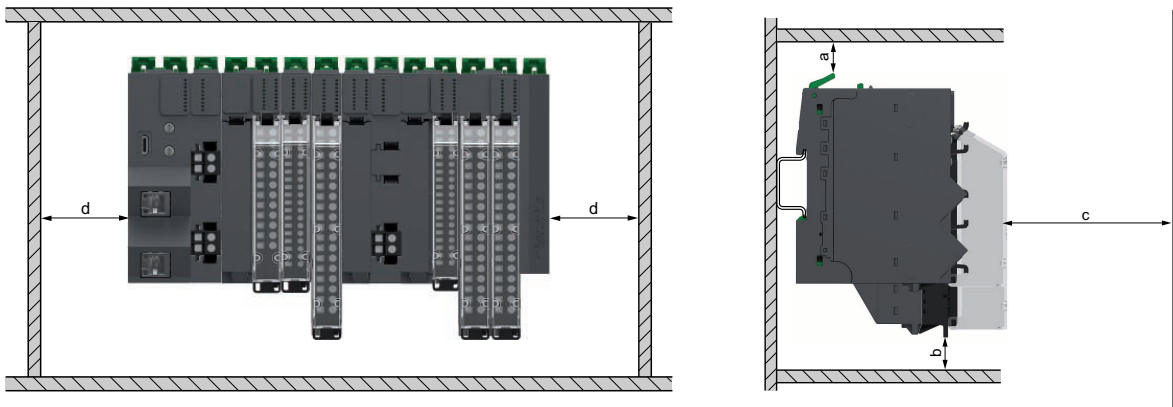

- a: 50 mm (1.97 in)
- b: Without EMC kit: 25 mm (0.98 in), with EMC kit: 55 mm (2.16 in)
- c: 80 mm (3.15 in)
- d: 25 mm (0.98 in)

Thermal Considerations

For adequate heat dissipation, you must provide adequate clearance around your Modicon Edge I/O NTS system. It is a good practice to mount the Modicon Edge I/O NTS system at the bottom of the enclosure.

To estimate the power dissipation for your system and enclosure cooling, refer to the user manual of each module.

These values are based on the maximum bus voltage, maximum field-side voltage, and maximum load currents.

⚠ WARNING

UNINTENDED EQUIPMENT OPERATION

- Place devices dissipating the most heat at the top of the cabinet and ensure adequate ventilation.
- Do not place this equipment next to or above devices that might cause overheating.
- Install the equipment in a location with the minimum clearance from all adjacent structures and equipment as directed in the present document.
- Install all equipment in accordance with the specifications in the related documentation.

Failure to follow these instructions can result in death, serious injury, or equipment damage.

NOTE: You must provide adequate clearance for adequate ventilation and to maintain an ambient temperature. Maximum ambient temperature depends on the mounting position.

Mounting Positions

Correct Mounting Position

Mount the Modicon Edge I/O NTS system horizontally on a vertical plane as shown in the following figures:

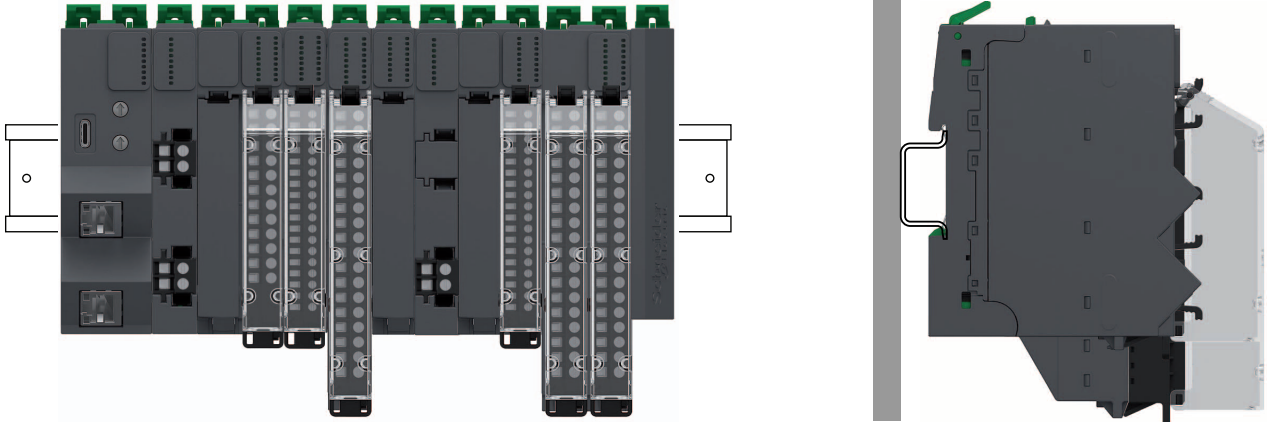

NOTE: You must provide adequate clearance for adequate ventilation and to maintain an ambient temperature as described in the environmental characteristics, page 37.

Acceptable Mounting Positions

The Modicon Edge I/O NTS system can be mounted in two positions with a temperature derating, page 37:

- Horizontally on a horizontal plane as shown in the following figure:

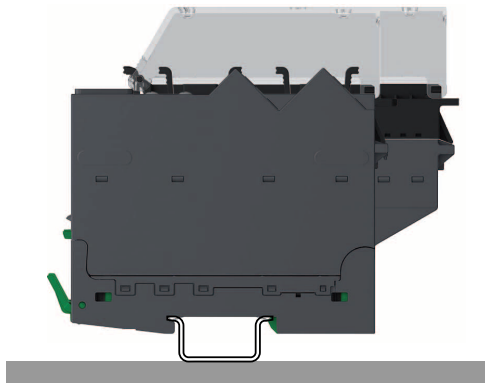

- Vertically on a vertical plane as shown in the following figures:

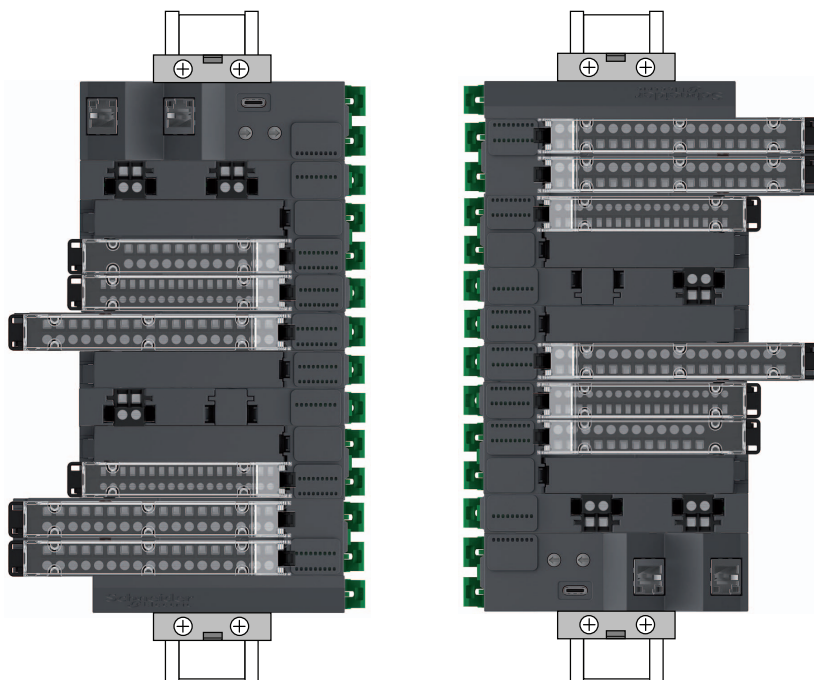

Incorrect Mounting Position

The system should only be positioned as shown in the [Correct Mounting Position](#), page 43 or the [Acceptable Mounting Positions](#), page 44. The following illustration shows the incorrect mounting positions:

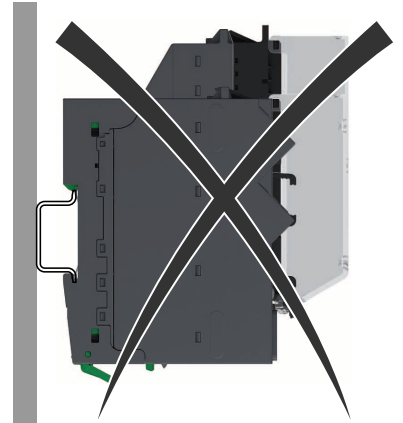
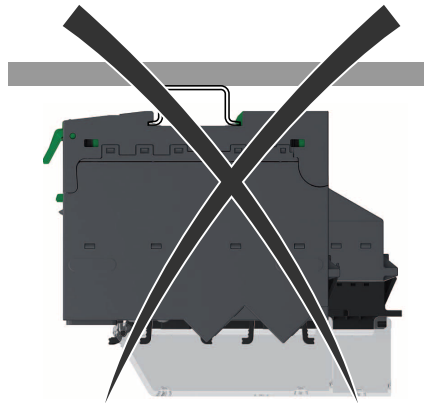

Modicon Edge I/O NTS Power Distribution

What's in This Chapter

Power Distribution Description.....	46
Power Distribution System Implementation	47

Power Distribution Description

The Modicon Edge I/O NTS system uses two distinct power rails to distribute power to the modules:

- The 24 Vdc bus distributes power to the internal processing and illuminates the LEDs of the modules.
- The 24 Vdc field power distributes power to the front-end processing and interface with actuators or sensors.

In a cluster, the second module of the Modicon Edge I/O NTS must be a Power supply Field and Bus module (PFB), which distributes power to:

- The network interface module
- The 24 Vdc bus
- The 24 Vdc field power

Power supply Field Distribution modules (PFD) can be added in a cluster to distribute the 24 Vdc over the 24 Vdc field power segment.

You can add a Power supply Field Distribution module to:

- Divide the 24 Vdc field power segment into separate segments, if needed.
- Provide supplementary power to the 24 Vdc field power segment by dividing it into separate segments, based on your I/O configuration.

To supply power to these modules, use an external SELV 24 Vdc power supply.

NOTE: A Power supply Field Distribution module does not distribute current on the bus power.

The following illustration presents how the power is distributed in the 24 Vdc bus and the 24 Vdc field power segments:

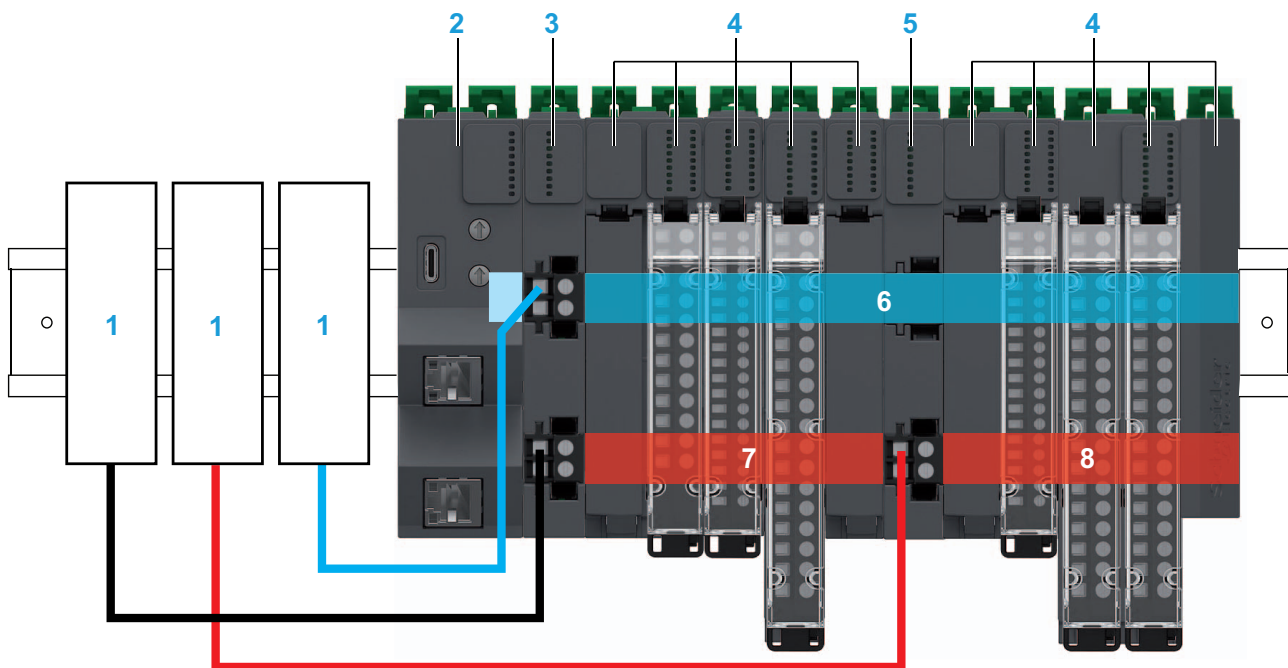

- 1: External power supply
- 2: Network interface module
- 3: Power supply Field and Bus module
- 4: I/O module
- 5: Power supply Field Distribution module
- 6: 24 Vdc bus
- 7: 24 Vdc field power segment 1
- 8: 24 Vdc field power segment 2

Power Supply Module Mounting Rules

Installing a Power supply Field and Bus or a Power supply Field Distribution creates a separate 24 Vdc field power segment to the right of the module.

⚠ WARNING
UNINTENDED EQUIPMENT OPERATION
Do not mount a Power supply Field Distribution module (PFD) next to any one of the following modules:
<ul style="list-style-type: none"> • Power supply Field and Bus • Power supply Field Distribution
Failure to follow these instructions can result in death, serious injury, or equipment damage.

Power Distribution System Implementation

The power distribution system supplies power to both the 24 Vdc field power segment and the 24 Vdc bus for the configuration.

Follow this order when planning your Modicon Edge I/O NTS power distribution:

Step	Description
1	Plan your Edge I/O System.
2	(Optionally) Create 24 Vdc field power segments by adding Power supply Field Distribution modules. For example, to separate the input modules from output modules or to separate the AC modules from DC modules.
3	Calculate the current consumed on each 24 Vdc field power segment and add additional Power supply Field Distribution modules to create segments.

NOTE: When configuring your Modicon Edge I/O NTS system with the Modicon Edge I/O Configurator (NTSCSW1000) or Modicon Edge I/O NTS Web Interface, the software computes the current consumption on the 24 Vdc bus and the 24 Vdc field power segments according to your design.

Current Consumed on the 24 Vdc Bus

The current consumed on the Modicon Edge I/O 24 Vdc bus is composed of:

- The current consumed by the module bases
- The current consumed by the electronic modules

For more information about current consumed on the 24 Vdc bus, refer to *Current Consumption Tables for the Bus Power and 24 Vdc I/O Field Power Segment*, page 159.

NOTE: You can use the Modicon Edge I/O Configurator (NTSCSW1000) software or the Modicon Edge I/O Web Interface to get a view of the estimated power consumption, refer to *Modicon Edge I/O - Configurator and Web Interface - User Guide*.

Current Consumed on the 24 Vdc Field Power Segment

The current consumed on the 24 Vdc field power segment is composed of:

- The current consumed by the electronic modules⁽¹⁾.
- The current consumed by the loads connected to the DC outputs of the modules supplied by the 24 Vdc field power segment.
- The current consumed to supply the sensors and actuators connected to the electronic modules.
- The current consumed to supply external devices connected to the Common Distribution Modules.

NOTE: ⁽¹⁾ For electronic modules with 24 Vdc inputs, this current includes the input signal currents for all inputs in activated state.

For more information about current consumed on the 24 Vdc field power, refer to *Current Consumption Tables for the Bus Power and 24 Vdc I/O Field Power Segment*, page 159.

NOTE: You can use the Modicon Edge I/O Configurator (NTSCSW1000) software or the Modicon Edge I/O Web Interface to get a view of the estimated power consumption. For more information, refer to *Modicon Edge I/O - Configurator and Web Interface - User Guide*.

Electrical Requirements

What's in This Chapter

Wiring Best Practices.....49
 Characteristics of the 24 Vdc Bus Power Supply 53
 Characteristics of the 24 Vdc Field Power Supply 53
 Calculating the Power Supply Requirement..... 53

Wiring Best Practices

Wiring Rules

There are several rules that must be followed when wiring the Modicon Edge I/O system.

⚡⚡ DANGER

HAZARD OF ELECTRIC SHOCK, EXPLOSION OR ARC FLASH

- Disconnect all power from all equipment including connected devices prior to removing any covers or doors, or installing or removing any accessories, hardware, cables, or wires except under the specific conditions specified in the appropriate hardware guide for this equipment.
- Always use a properly rated voltage sensing device to confirm the power is off where and when indicated.
- Replace and secure all covers, accessories, hardware, cables, and wires and confirm that a proper ground connection exists before applying power to the unit.
- Use only the specified voltage when operating this equipment and any associated products.

Failure to follow these instructions will result in death or serious injury.

The following rules must be applied when wiring the Modicon Edge I/O system:

- I/O and communication wiring must be kept separate from the power wiring. Route these 2 types of wiring in separate cable ducting.
- Verify that the operating conditions and environment are within the specification values.
- Use proper wire sizes to meet voltage and current requirements.
- Use copper conductors only.
- Use twisted pair, shielded cables for analog I/O, counting I/O, encoders, networks and fieldbus.
- Use conductors with a temperature rating of at least 80 °C (176 °F).

Use shielded, properly grounded cables for all analog and high-speed inputs or outputs and communication connections. If you do not use shielded cables for these connections, electromagnetic interference can cause signal degradation. Degraded signals can cause the controller or attached modules and equipment to perform in an unintended manner.

⚠ WARNING

UNINTENDED EQUIPMENT OPERATION

- Use shielded cables for all fast I/O, analog I/O and communication signals.
- Ground cable shields for all analog I/O, fast I/O and communication signals at a single point¹.
- Route communication and I/O cables separately from power cables.

Failure to follow these instructions can result in death, serious injury, or equipment damage.

¹Multipoint grounding is permissible if connections are made to an equipotential ground plane dimensioned to help avoid cable shield damage in the event of power system short-circuit currents.

Refer to the section *Grounding the system*, page 54 to ground the shielded cables.

Wire sizes depend on the terminal block reference. For more information, refer to *Terminal Blocks*, page 132.

⚠ DANGER

FIRE HAZARD

- Use only the correct wire sizes for the maximum current capacity of the I/O channels and power supplies.
- For relay output (5 A) wiring, use conductors of at least 0.5 mm² (AWG 20) with a temperature rating of at least 80 °C (176 °F).
- For common conductors of relay output wiring (8 A), or relay output wiring greater than 5 A, use conductors of at least 1.0 mm² (AWG 16) with a temperature rating of at least 80 °C (176 °F).

Failure to follow these instructions will result in death or serious injury.

The spring clamp connectors of the terminal block are designed for only one wire or one cable end. Two wires to the same connector must be installed with a double wire cable end to help prevent loosening.

⚡⚠ DANGER

LOOSE WIRING CAUSES ELECTRIC SHOCK

Do not insert more than one wire per connector of the spring terminal blocks unless using a double wire cable end (ferrule).

Failure to follow these instructions will result in death or serious injury.

Terminal Block

Inserting an incorrect terminal block into the module can cause unintended operation of the application and/or damage the electronic module.

⚠️⚠️ DANGER

ELECTRIC SHOCK OR UNINTENDED EQUIPMENT OPERATION

Connect the terminal blocks to their designated location.

Failure to follow these instructions will result in death or serious injury.

NOTE: To help prevent a terminal block from being inserted incorrectly, ensure that each terminal block and electronic module is clearly and uniquely coded, refer to *Coding the Modicon Edge I/O NTS*, page 83.

Protecting Outputs from Inductive Load Damage

Depending on the load, a protection circuit may be needed for the outputs on the controllers and certain modules. Inductive loads using DC voltages may create voltage reflections resulting in overshoot that will damage or shorten the life of output devices.

⚠️ WARNING

INDUCTIVE LOADS

Use an appropriate external protective circuit or device to reduce the risk of inductive direct current load damage.

Failure to follow these instructions can result in death, serious injury, or equipment damage.

If your controller or module contains relay outputs, these types of outputs can support up to 240 Vac. Inductive damage to these types of outputs can result in welded contacts and loss of control. Each inductive load must include a protection device such as a peak limiter, RC circuit or flyback diode. Capacitive loads are not supported by these relays.

⚠️ WARNING

RELAY OUTPUTS WELDED CLOSED

- Always protect relay outputs from inductive alternating current load damage using an appropriate external protective circuit or device.
- Do not connect relay outputs to capacitive loads.

Failure to follow these instructions can result in death, serious injury, or equipment damage.

Protective circuit A: this protection circuit can be used for both AC and DC load power circuits.

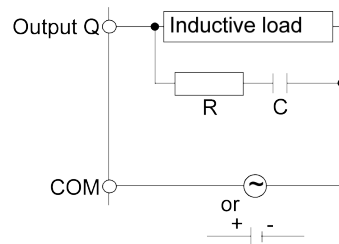

C Value from 0.1 to 1 μF

R Resistor of approximately the same resistance value as the load

Protective circuit B: this protection circuit can be used for DC load power circuits.

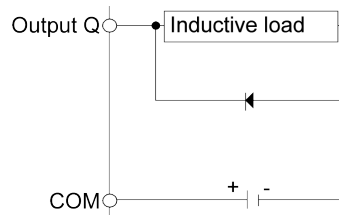

Use a diode with the following ratings:

- Reverse withstand voltage: power voltage of the load circuit x10.
- Forward current: more than the load current.

Protective circuit C: this protection circuit can be used for both AC and DC load power circuits.

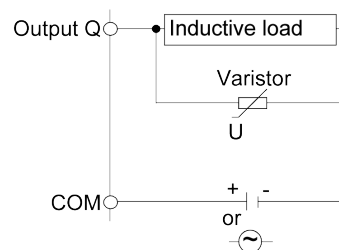

In applications where the inductive load is switched on and off frequently and/or rapidly, ensure that the continuous energy rating (J) of the varistor exceeds the peak load energy by 20 % or more.

Characteristics of the 24 Vdc Bus Power Supply

To distribute current for the 24 Vdc bus according to the power distribution system, page 47, the Power supply Field and Bus module connector CN2 is supplied by an external Safety Extra-Low Voltage (SELV) power supply with the following characteristics:

Characteristic	Value / Description
Nominal current	3.5 A
Nominal voltage	24 Vdc
Power interruption hold-up time on bus	Continues normal operation for a duration of 10 ms minimum.

Use a certified, external 1P or 2P 3.5 A 230 V or equivalent fuse.

⚠ WARNING
<p>POTENTIAL OF OVERHEATING AND FIRE</p> <ul style="list-style-type: none"> Do not connect the modules directly to line voltage. Use only isolating SELV power supplies to supply power to the modules. <p>Failure to follow these instructions can result in death, serious injury, or equipment damage.</p>

Characteristics of the 24 Vdc Field Power Supply

To distribute current for the 24 Vdc Field Power according to the power distribution system, page 47, the Power supply Field and Bus and the Power supply Field Distribution module connector CN1 are supplied by an external Safety Extra-Low Voltage (SELV) power supply with the following characteristics:

Characteristic	Value / Description
Nominal current	10.5 A
Nominal voltage	24 Vdc
Power interruption hold-up time on bus	-

Use a certified, external 1P or 2P 10.5 A 230 V or equivalent fuse.

⚠ WARNING
<p>POTENTIAL OF OVERHEATING AND FIRE</p> <ul style="list-style-type: none"> Do not connect the modules directly to line voltage. Use only isolating SELV power supplies to supply power to the modules. <p>Failure to follow these instructions can result in death, serious injury, or equipment damage.</p>

Calculating the Power Supply Requirement

Refer to Power Distribution System Implementation, page 47

Grounding the system

What's in This Chapter

Overview	54
Protective Ground (PE) on the Backplane	55
Functional Ground (FE) on the DIN Rail	55
Shielded Cables Connections	56

Overview

Use shielded, properly grounded cables for all analog and high-speed inputs or outputs and communication connections. If you do not use shielded cables for these connections, electromagnetic interference can cause signal degradation. Degraded signals can cause the controller or attached modules and equipment to perform in an unintended manner.

⚠ WARNING

UNINTENDED EQUIPMENT OPERATION

- Use shielded cables for all fast I/O, analog I/O and communication signals.
- Ground cable shields for all analog I/O, fast I/O and communication signals at a single point¹.
- Route communication and I/O cables separately from power cables.

Failure to follow these instructions can result in death, serious injury, or equipment damage.

¹Multipoint grounding is permissible if connections are made to an equipotential ground plane dimensioned to help avoid cable shield damage in the event of power system short-circuit currents.

The use of shielded cables requires compliance with the following wiring rules:

- For protective ground connections (PE), metal conduit or ducting can be used for part of the shielding length, provided there is no break in the continuity of the ground connections. For functional ground (FE), the shielding is intended to attenuate electromagnetic interference and the shielding must be continuous for the length of the cable. If the purpose is both functional and protective, as is often the case for communication cables, the cable should have continuous shielding.
- Wherever possible, keep cables carrying one type of signal separate from the cables carrying other types of signals or power.

The following illustration presents a Modicon Edge I/O NTS cluster with shielded cables:

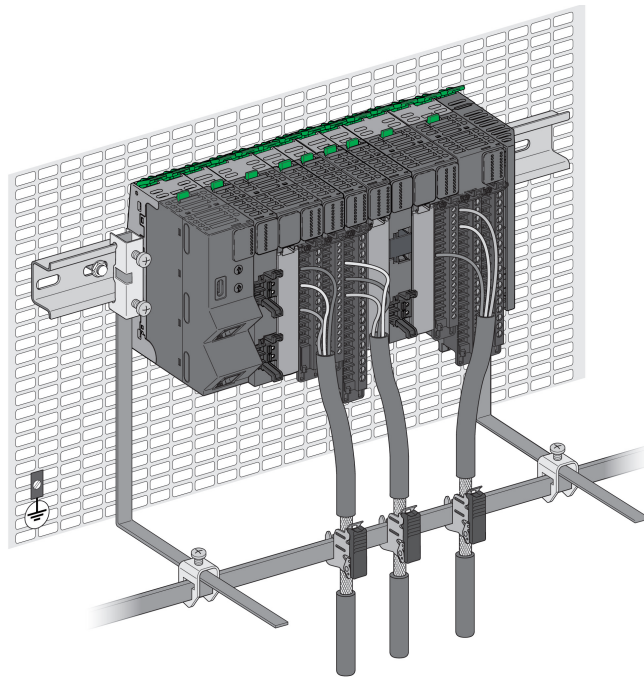

Protective Ground (PE) on the Backplane

The protective ground (PE) is connected to the conductive backplane by a heavy-duty wire, usually a braided copper cable with a cross-section of 6 mm² (AWG 10) or larger.

Functional Ground (FE) on the DIN Rail

The DIN Rail for your Modicon Edge I/O NTS is common with the functional ground (FE) plane and must be mounted on a conductive backplane.

⚠ WARNING

UNINTENDED EQUIPMENT OPERATION

Connect the DIN rail to the protective ground (PE) of your installation.

Failure to follow these instructions can result in death, serious injury, or equipment damage.

The connection between the functional ground (FE) and your Modicon Edge I/O NTS is made by the DIN Rail contacts on the back of the bus base of the expansion modules.

For more information about the installation of the DIN rail, refer to DIN Rail Installation, page 64.

Shielded Cables Connections

Cables carrying the analog I/O, counting I/O, motion I/O, encoders, networks and fieldbus communication signals must be shielded. The shielding must be securely connected to ground:

- The analog I/O, counting I/O, motion I/O, encoders, networks and fieldbus shields may be connected either to the functional ground (FE) of your system using an EMC kit or to the protective ground (PE).
- The bus communication cable shields must be connected to the protective ground (PE) with a connecting clamp secured to the conductive backplane of your installation.

⚠ WARNING

ACCIDENTAL DISCONNECTION FROM PROTECTIVE GROUND (PE)

- Do not use the EMC kit to provide a protective ground (PE).
- Use the EMC kit only to provide a functional ground (FE).

Failure to follow these instructions can result in death, serious injury, or equipment damage.

Installation Procedures

What's in This Part

Installation and Maintenance Requirements	58
Installation Walkthrough.....	60
The Layout of your Modicon Edge I/O NTS Island	62
DIN Rail Installation	64
Network Interface Module Installation	66
I/O Module Installation	69
Equipment Removal	81
Coding the Modicon Edge I/O NTS	83
Labeling the Module	85
Plain Text Installation on Clear Cover.....	86

Installation and Maintenance Requirements

What's in This Chapter

Before Starting 58
 Disconnecting Power 58
 Programming Considerations 59
 Operating Environment Considerations 59
 Installation Considerations 59

Before Starting

Read and understand this chapter before beginning the installation of your system.

The use and application of the information contained herein require expertise in the design and programming of automated control systems. Only you, the user, machine builder or integrator, can be aware of all the conditions and factors present during installation and setup, operation, and maintenance of the machine or process, and can therefore determine the automation and associated equipment and the related safeties and interlocks which can be effectively and properly used. When selecting automation and control equipment, and any other related equipment or software, for a particular application, you must also consider any applicable local, regional or national standards and/or regulations.

Pay particular attention in conforming to any safety information, different electrical requirements, and normative standards that would apply to your machine or process in the use of this equipment.

Disconnecting Power

All options and modules should be assembled and installed before installing the control system on a mounting rail, onto a mounting plate or in a panel. Remove the control system from its mounting rail, mounting plate or panel before disassembling the equipment.

DANGER

HAZARD OF ELECTRIC SHOCK, EXPLOSION OR ARC FLASH

- Disconnect all power from all equipment including connected devices prior to removing any covers or doors, or installing or removing any accessories, hardware, cables, or wires except under the specific conditions specified in the appropriate hardware guide for this equipment.
- Always use a properly rated voltage sensing device to confirm the power is off where and when indicated.
- Replace and secure all covers, accessories, hardware, cables, and wires and confirm that a proper ground connection exists before applying power to the unit.
- Use only the specified voltage when operating this equipment and any associated products.

Failure to follow these instructions will result in death or serious injury.

Programming Considerations

▲ WARNING
<p>UNINTENDED EQUIPMENT OPERATION</p> <ul style="list-style-type: none"> • Only use software approved by Schneider Electric for use with this equipment. • Update your application program every time you change the physical hardware configuration. <p>Failure to follow these instructions can result in death, serious injury, or equipment damage.</p>

Operating Environment Considerations

▲ WARNING
<p>UNINTENDED EQUIPMENT OPERATION</p> <p>Install and operate this equipment according to the conditions described in the Environmental Characteristics.</p> <p>Failure to follow these instructions can result in death, serious injury, or equipment damage.</p>

For more information on operating environments, refer to the environmental characteristics, page 37.

NOTE: Use contact protection grease (BMXGEL0025) to cover all connections on Modicon Edge I/O devices used in a corrosive environment.

Installation Considerations

▲ WARNING
<p>UNINTENDED EQUIPMENT OPERATION</p> <ul style="list-style-type: none"> • Use appropriate safety interlocks where personnel and/or equipment hazards exist. • Install and operate this equipment in an enclosure appropriately rated for its intended environment and secured by a keyed or tooled locking mechanism. • Use the sensor and actuator power supplies only for supplying power to the sensors or actuators connected to the module. • Power line and output circuits must be wired and fused in compliance with local and national regulatory requirements for the rated current and voltage of the particular equipment. • Do not use this equipment in safety-critical machine functions unless the equipment is otherwise designated as functional safety equipment and conforming to applicable regulations and standards. • Do not disassemble, repair, or modify this equipment. • Do not connect any wiring to reserved, unused connections, or to connections designated as No Connection (N.C.). <p>Failure to follow these instructions can result in death, serious injury, or equipment damage.</p>

NOTE: JDYX2 or JDYX8 fuse types are UL-recognized.

Installation Walkthrough

What's in This Chapter

Overview	60
Installation - Phase 1	60
Installation - Phase 2	60
Installation - Phase 3	61

Overview

This chapter provides a summary of the installation process. The information is presented in generalized steps which convey each of the operations that are required in the installation process. Each step is accompanied by a reference that locates the detailed information associated with it.

The installation process is divided into three phases.

Installation - Phase 1

In the first phase of the installation, install the DIN rail and the network interface module that is part of your Modicon Edge I/O NTS configuration:

Step	Action	Refer to
1	Develop an installation plan that covers all aspects of the installation.	Planning the Installation, page 62
2	Fasten the DIN rail to the mounting plate of the enclosure.	DIN Rail Installation, page 64
3	Determine the left-to-right arrangement of the modules on the rail.	-
5	For a distributed configuration, install the network interface module at the first (leftmost) location on the rail.	Mounting a network interface module, page 67.
7	Install the Power supply Field and Bus at the second (leftmost) location on the rail.	Mounting a Power supply Field and Bus, page 78.

Installation - Phase 2

In the second phase of the installation, install the kits and terminal blocks with or without coding:

Step	Action	Refer to
1	Develop a coding scheme for the kits and the terminal blocks that matches the layout of the modules.	Coding the Modicon Edge I/O NTS, page 83
2	Install the kits in accordance with your layout of the modules.	Mounting a kit on the DIN rail, page 71
3	Mount the terminal blocks in accordance with your layout of the modules.	Mounting a terminal block on a module, page 74

Installation - Phase 3

In the final phase, you install cable ducts, connect all grounding points, make the necessary signal and power connections, and commission your Modicon Edge I/O NTS.

Step	Action	Refer to
1	Install the EMC kit.	-
2	Install cable ducts, conduits and any wiring harnesses.	-
3	Make Functional Ground (FE) connections.	Grounding the Modicon Edge I/O NTS, page 54
4	Make Protective Ground (PE) connections.	Grounding the Modicon Edge I/O NTS, page 54

The Layout of your Modicon Edge I/O NTS Island

What's in This Chapter

Planning the Installation 62
 Selecting Modicon Edge I/O NTS Modules 62

Planning the Installation

Before you begin installation of your Modicon Edge I/O system, you must establish a plan that identifies:

- The number and type of modules on your Modicon Edge I/O system.
- The power requirements of your Modicon Edge I/O system configuration.
- The order in which any Modicon Edge I/O NTS modules are assembled together.
- The type of enclosure for the Modicon Edge I/O NTS system.
- A coding scheme that helps match the terminal blocks with their electronic modules.
- A labeling system with plain texts on the clear cover and marking labels.

Selecting Modicon Edge I/O NTS Modules

When you plan a Modicon Edge I/O NTS system layout, you must know the number and type of modules and terminal blocks in your system.

NOTE: There are restrictions and regulations associated with certain module types. For more information, refer to the user guides of the module.

You can, for any reason, reserve module slots in your Modicon Edge I/O NTS layout. Any reserved module slot must be filled by a dummy module (NTSDMY0100H).

<i>NOTICE</i>
COMMUNICATION ERROR
Use a dummy module for all reserved module slots.
Failure to follow these instructions can result in equipment damage.

The **Device Mode** feature allows you to create a standard island configuration and make depopulated variations of that configuration that share the same fieldbus process image. This allows to maintain a single application program for various island configurations.

The depopulated islands are configured by declaring the intended modules and you can declare any of the Modicon Edge I/O NTS input and output modules to be **Normal** (default value), **Optional** or **Virtual reserved** with the **Device Mode** parameter:

- **Normal:** The module is part of the software configuration and is physically connected in the cluster.
- **Optional:** The module is part of the software configuration. A dummy module or the configured module must be physically installed in the cluster. Whether either module is present does not cause a configuration error to be detected.
- **Virtual reserved:** The module is part of the software configuration. A dummy module must be physically installed in the cluster. If the virtual module is physically installed in the cluster, a configuration error is detected.

When a module is configured as **Optional** or **Virtual reserved**, the memory mapping of the island is retained and modules marked as not present retain their slot addresses. This allows you to physically modify the design of your island, without having to edit your application program.

After the number and type of modules are established, you can determine power distribution requirements, page 46, your external power source requirements, page 49 and the overall hardware design.

DIN Rail Installation

What's in This Chapter

Grounding Function	64
Mounting the DIN Rail	64
DIN Rail End Stoppers	65

Grounding Function

The DIN rail must be attached to a conductive backplane that is connected to a protective ground (PE).

Each base is equipped with several metal spring contacts. When properly mounted on a metal DIN rail, these contacts provide connection to the functional ground (FE) for the entire system.

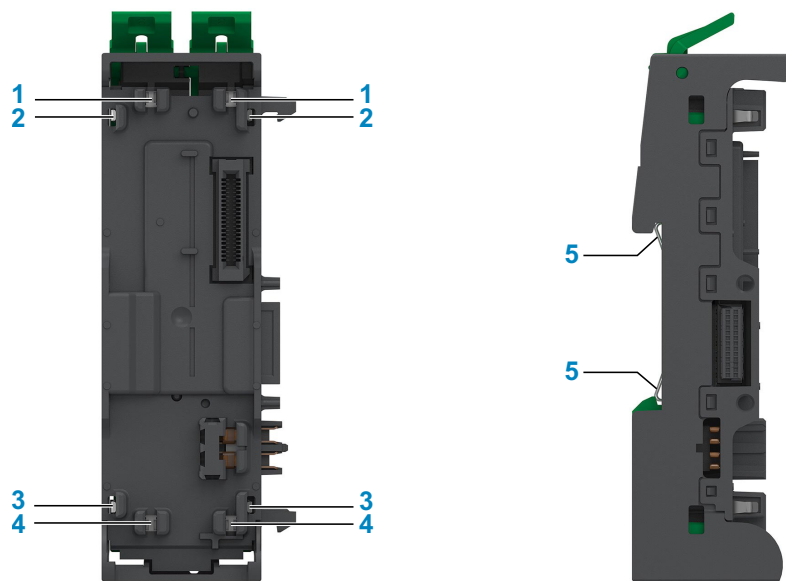

1,2,3,4,5: Ground Contacts

To help achieve the electrostatic discharge and electromagnetic compatibility stated performances, use a rail connected to a backplane with good electrical conductive surfaces.

Mounting the DIN Rail

The Modicon Edge I/O system is designed to be mounted on a DIN rail (35 x 7.5 mm or 35 x 15 mm) made from an electro zinc-plated steel according to IEC60715. For EMC (Electromagnetic Compatibility) compliance, a metal DIN rail must be attached to a flat metal mounting surface or mounted on an EIA (Electronic Industries Alliance) rack or in a NEMA (National Electrical Manufacturers Association) cabinet enclosure.

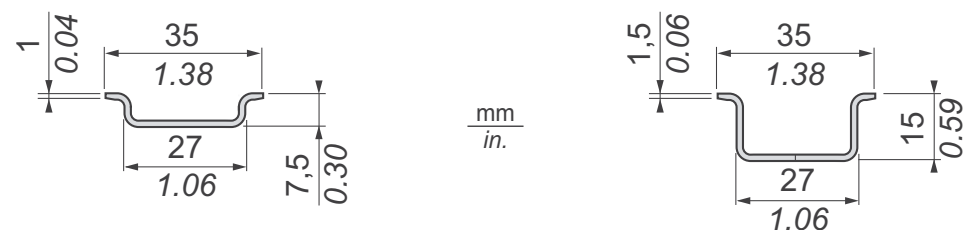

The following DIN rails are supported for use with the Modicon Edge I/O systems:

Reference	Rail Depth
NSYSDR200BD	7.5 mm (0.27 in.)
NSYSDR200D	15 mm (0.59 in.)

The mounting hardware must be installed at the end positions and at 100 mm (3.94 in) maximum increments along the length of the rail.

The following illustration presents the mounting requirements for the DIN rail:

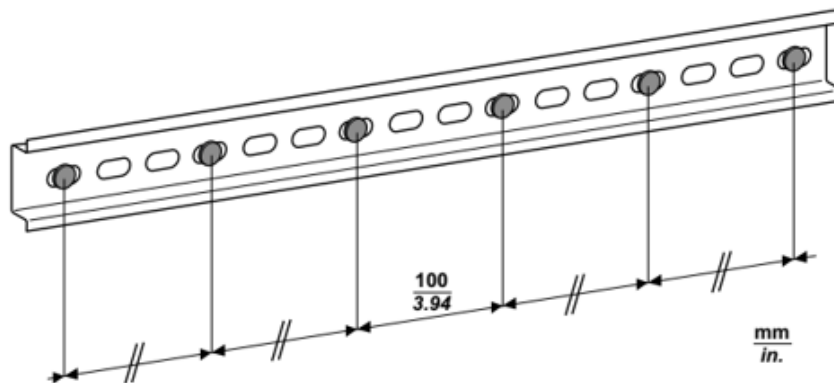

⚠ WARNING	
UNINTENDED EQUIPMENT OPERATION	
<ul style="list-style-type: none"> • Verify that the DIN rail is securely installed with mounting hardware at the end positions and at 100 mm (3.94 in.) maximum increments along the length of the rail. • Verify that the DIN rail is firmly connected to a conductive backplane, and that the conductive backplane is secured to a protective ground as specified in this guide and in accordance with local regulations. 	
Failure to follow these instructions can result in death, serious injury, or equipment damage.	

DIN Rail End Stoppers

For installation where vibration can occur, the elements of the Modicon Edge I/O cluster must be secured against slipping. A set of two end stoppers (NSYTRAABV35) can be used to help secure the configuration.

Step	Action
1	Place the end stoppers on the DIN rail on each side of the cluster.
2	Screw the end stoppers down tightly using the screwdriver (maximum torque 2.5 Nm).

Network Interface Module Installation

What's in This Chapter

Mounting a Network Interface Module Kit on the DIN Rail	67
Removing a Network Interface Module Kit from the DIN Rail	68

Mounting a Network Interface Module Kit on the DIN Rail

Before installing your network interface module, choose the exact location on the DIN rail where you want to place the network interface module kit on the rail.

When choosing the location, verify that:

- Sufficient space to the right of the network interface module is reserved for mounting the other modules on the DIN rail.
- You have reserved enough space for any DIN-mounted external devices you intend to use, such as source power supplies and safety relays.
- For 7.5 mm (0.30 in.) deep rails, no mounting screws protrude in the area where the cluster modules will be installed.

The following procedure describes how to mount a network interface module kit on the DIN rail:

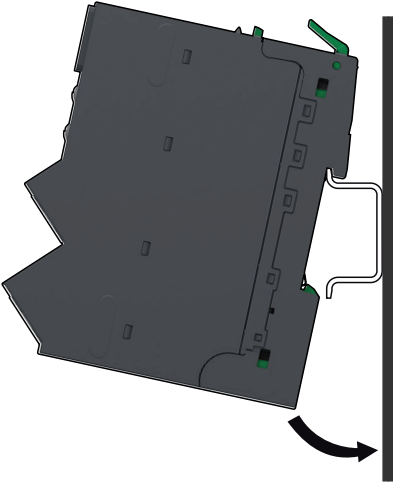
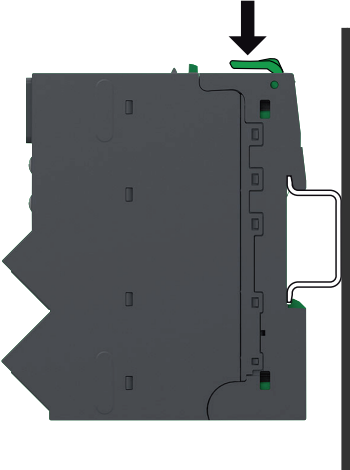
Step	Action
1	Remove the NTSXMP0000H Cluster Termination from the network interface module kit package and set it aside for later use.
2	Before inserting the kit on DIN rail, pull the base locker upward to set it in the releasing position.
3	Place the network interface module on the DIN rail and press it down firmly. It must click into place. 
4	Push the base locker downward to set it in the locking position. 

Removing a Network Interface Module Kit from the DIN Rail

The following procedure describes how to remove a Network Interface Module kit from the DIN rail:

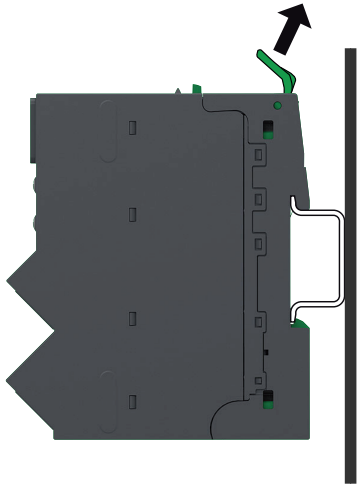
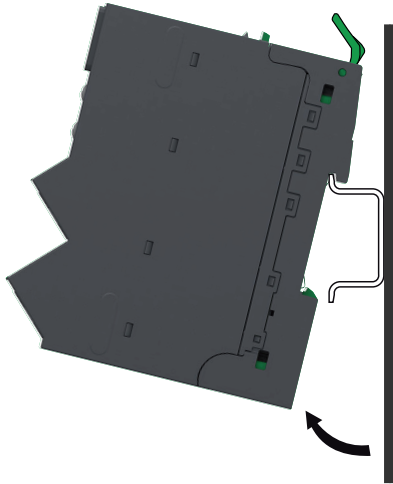
Step	Action
1	Remove any kits that are mounted to the right of the network interface module, following the procedure <i>Removing a Kit from the DIN Rail</i> , page 73.
2	Pull the base locker upward to set it in the releasing position. 
3	Pull the kit from the DIN rail. 

I/O Module Installation

What's in This Chapter

- Overview 69
- Mounting a Module on a Base 70
- Removing a Module from a Base 71
- Mounting a Kit on the DIN Rail 71
- Removing a Kit from the DIN Rail 73
- Mounting a Terminal Block on a Module 74
- Removing a Terminal Block from a Module 76
- Mounting a Terminal Block on a PFB or PFD 78
- Removing a Terminal Block from a PFB or PFD 79
- Mounting a Cluster Termination on the DIN Rail 80
- Removing a Cluster Termination from the DIN Rail 80

Overview

To install the Modicon Edge I/O NTS modules on the DIN rail, proceed as follows:

Step	Action
1	Mounting a Module on a Base, page 70.
2	Mounting a Kit on the DIN Rail, page 71.
3	Mounting a Terminal Block on a Module, page 74.

⚠ DANGER

INCOMPATIBLE COMPONENTS CAUSE ELECTRIC SHOCK OR ARC FLASH

- Do not proceed with the installation without first confirming the compatibility of the mounting kit components.
- Verify that correct terminal blocks are installed on the appropriate I/O modules.

Failure to follow these instructions will result in death or serious injury.

Mounting a Module on a Base

The following procedure describes how to mount the modules on their corresponding base:

NOTE: If you are replacing an existing module, follow the procedures for Hot Swapping Electronic Modules, page 91.

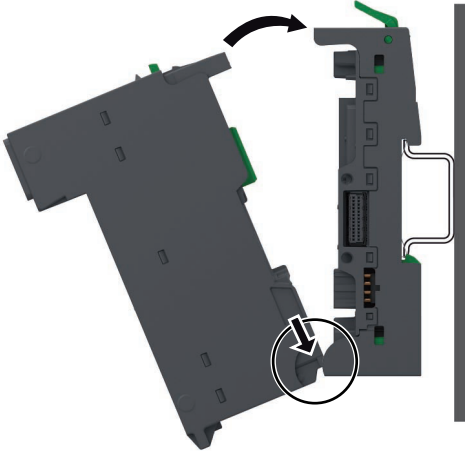
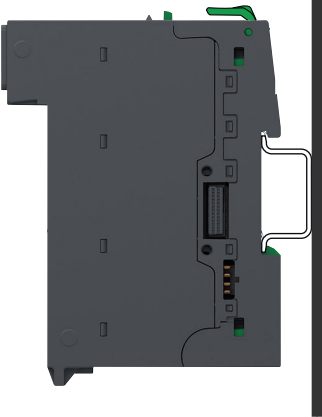
Step	Action
1	Insert the module in the guides of the base. 
2	Push the module straight into the base until it clicks. 
3	According to the installation plan, repeat these steps with all the modules.

NOTE: To help ascertain the compatibility between a base and a module, a color coding is applied on the front side of the base and on the rear side of the module. The color and the shape of the coding are the same for compatible bases and modules.

Removing a Module from a Base

The following procedure describes how to remove the module from the base:

NOTE: If you are replacing an existing module, follow the procedures for Hot Swapping Electronic Modules, page 91.

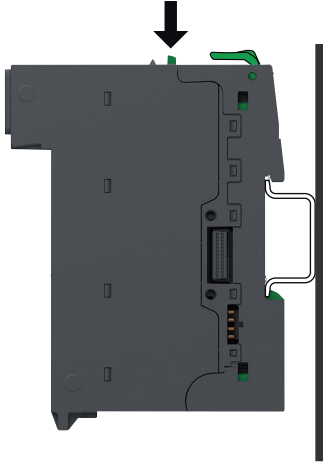
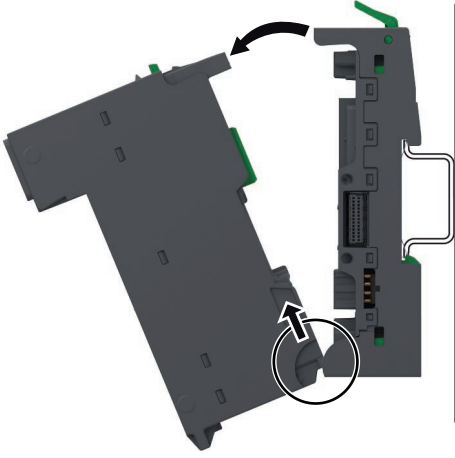
Step	Action
1	Remove the terminal block and electrical connector before removing the module.
2	Push the release button of the configuration to be removed. <div style="text-align: center;">  </div>
3	Pull the module and remove the module from the base. <div style="text-align: center;">  </div>

Mounting a Kit on the DIN Rail

Kits must be installed one by one and mounted on the DIN rail.

The DIN rail, page 64 and the Network Interface Module kit, page 66 must already be installed.

The following procedure describes how to mount a kit on the DIN rail:

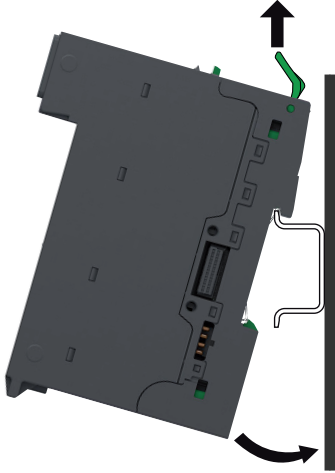
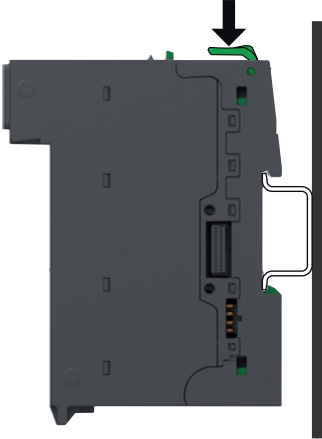
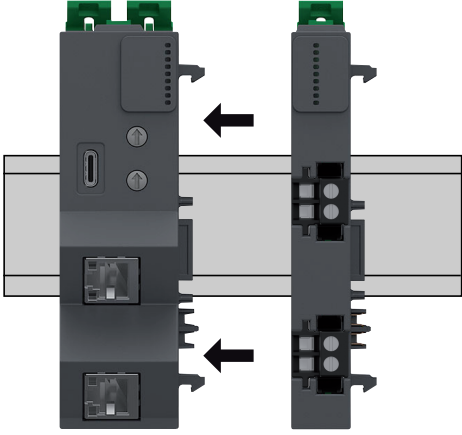
Step	Action
1	Pull the base locker upward to set it in the releasing position.
2	Place the kit on the DIN rail and press it down firmly. 
3	Push the base locker downward to set it in the locking position. 
4	Slide the module to the left until it clicks into place on the previously installed module. 
5	Repeat these steps to mount additional kits.

Removing a Kit from the DIN Rail

Kits must be removed one by one from right to left.

The following procedure describes how to remove a kit from the DIN rail:

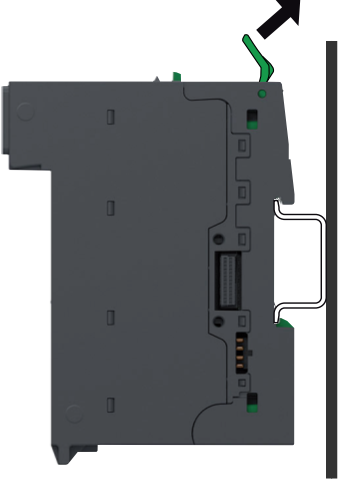
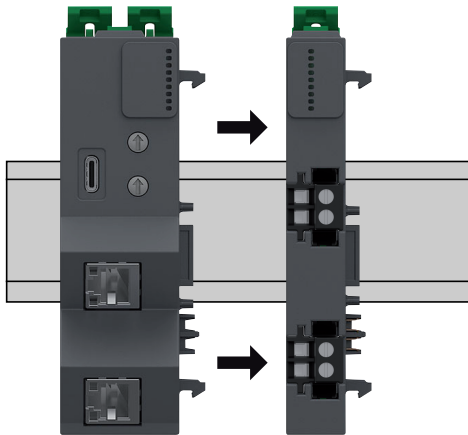
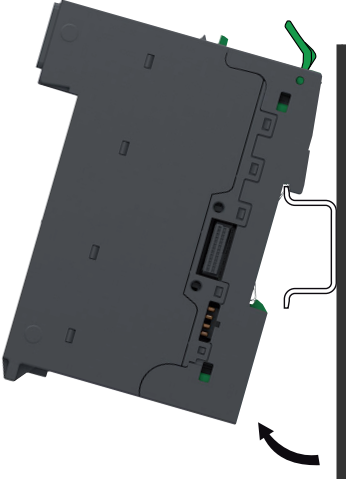
Step	Action
1	<p>Pull the base locker upward to set it in the releasing position.</p> 
2	<p>Slide the kit to the right on the DIN rail.</p> 
3	<p>Pull the kit from the DIN rail.</p> 
4	<p>Repeat these steps for each kit you want to remove.</p>

Mounting a Terminal Block on a Module

Always confirm the compatibility of the terminal block with the module before installation using the association table, page 151.

⚠ DANGER

INCOMPATIBLE COMPONENTS CAUSE ELECTRIC SHOCK OR ARC FLASH

- Do not install the terminal block on the module without first confirming its compatibility.
- Verify that correct terminal blocks are installed on the appropriate modules.

Failure to follow these instructions will result in death or serious injury.

Use coding keys and labeling tools to associate terminal blocks, modules and base plates, which can help minimize mounting and maintenance mismatches. For more information, refer to [Coding the Modicon Edge I/O NTS](#), page 83.

To mount a terminal block onto the module:

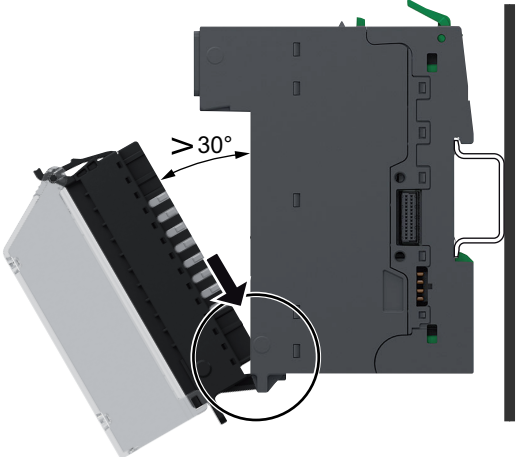
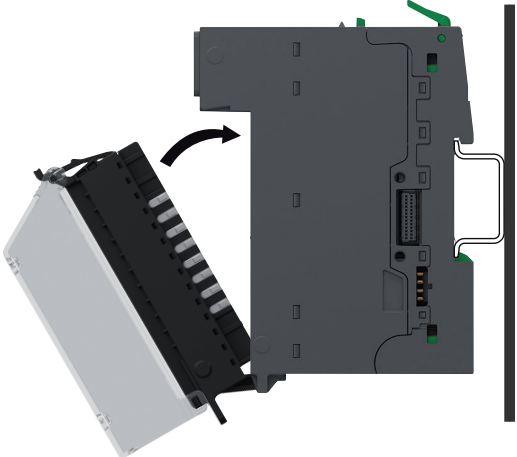
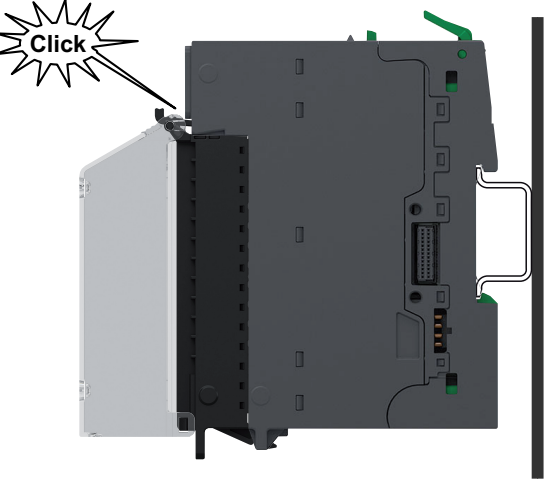
Step	Action
1	<p>Position the terminal block in front of the module, ensuring that the angle is greater than 30°.</p> 
2	<p>Push the terminal block into the hinge.</p> 
3	<p>Rotate the terminal block up into position until it clicks in place.</p> 
4	<p>According to the installation plan, repeat these steps for each terminal blocks.</p>

NOTE: The compatible terminal block references are printed on the front of the module.

Removing a Terminal Block from a Module

The following procedure describes how to remove the terminal block from a module:

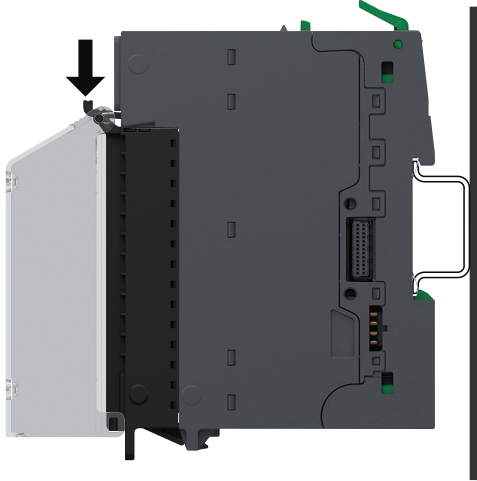
Step	Action
1	<p>Remove all power from all equipment.</p> <div style="background-color: black; color: white; padding: 5px; text-align: center;">  DANGER </div> <p>HAZARD OF ELECTRIC SHOCK, EXPLOSION OR ARC FLASH</p> <ul style="list-style-type: none"> Disconnect all power from all equipment including connected devices prior to removing any covers or doors, or installing or removing any accessories, hardware, cables, or wires except under the specific conditions specified in the appropriate hardware guide for this equipment. Always use a properly rated voltage sensing device to confirm the power is off where and when indicated. Replace and secure all covers, accessories, hardware, cables, and wires and confirm that a proper ground connection exists before applying power to the unit. Use only the specified voltage when operating this equipment and any associated products. <p>Failure to follow these instructions will result in death or serious injury.</p>
2	<p>Push down on the hook on the terminal block.</p> 

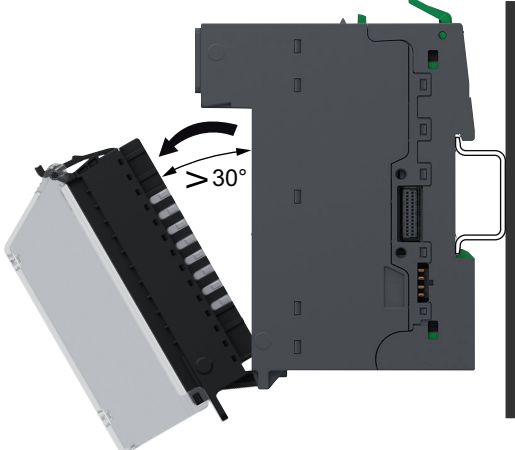
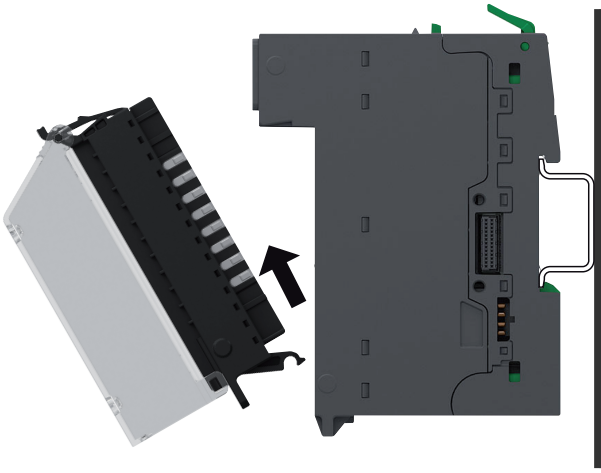
Step	Action
3	<p data-bbox="619 174 965 201">Pull the terminal block out and down.</p> 
4	<p data-bbox="619 721 997 748">Take the terminal block out of the hinge.</p> 

Mounting a Terminal Block on a PFB or PFD

⚡ ⚠ DANGER

HAZARD OF ELECTRIC SHOCK, EXPLOSION OR ARC FLASH

- Disconnect all power from all equipment including connected devices prior to removing any covers or doors, or installing or removing any accessories, hardware, cables, or wires except under the specific conditions specified in the appropriate hardware guide for this equipment.
- Always use a properly rated voltage sensing device to confirm the power is off where and when indicated.
- Replace and secure all covers, accessories, hardware, cables, and wires and confirm that a proper ground connection exists before applying power to the unit.
- Use only the specified voltage when operating this equipment and any associated products.

Failure to follow these instructions will result in death or serious injury.

To mount a terminal block onto the PFB or PFD module:

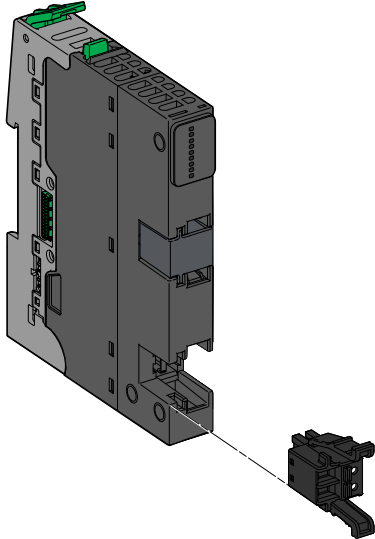
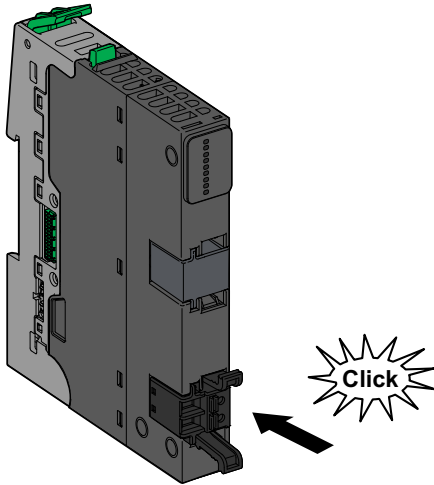
Step	Action
1	Align the terminal block with the slot of the module. 
2	Push the terminal block into the module until it clicks in place. 

Removing a Terminal Block from a PFB or PFD

⚠️ DANGER

HAZARD OF ELECTRIC SHOCK, EXPLOSION OR ARC FLASH

- Disconnect all power from all equipment including connected devices prior to removing any covers or doors, or installing or removing any accessories, hardware, cables, or wires except under the specific conditions specified in the appropriate hardware guide for this equipment.
- Always use a properly rated voltage sensing device to confirm the power is off where and when indicated.
- Replace and secure all covers, accessories, hardware, cables, and wires and confirm that a proper ground connection exists before applying power to the unit.
- Use only the specified voltage when operating this equipment and any associated products.

Failure to follow these instructions will result in death or serious injury.

To remove a terminal block from the PFB or PFD module:

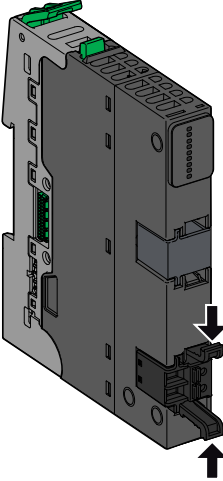
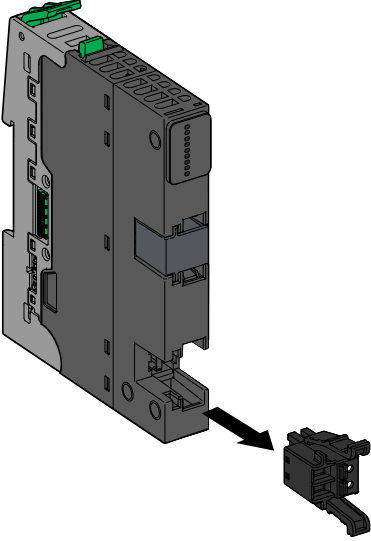
Step	Action
1	<p>Simultaneously press the two hooks of the terminal block.</p> 
2	<p>Pull the terminal block out of the module.</p> 

Mounting a Cluster Termination on the DIN Rail

To install the Cluster Termination, follow the [Mounting a Kit on the DIN Rail](#), page 71 procedure.

NOTE: The plate that shipped with the network interface module can be purchased separately as a spare part (NTSXMP0000H).

Removing a Cluster Termination from the DIN Rail

To remove the Cluster Termination, follow the [Removing a Kit from the DIN Rail](#), page 73 procedure.

Equipment Removal

What's in This Chapter

Complete Configuration Removal 81
 Partial Configuration Removal 82

Complete Configuration Removal

The following procedure describes how to remove a complete configuration:

Step	Action
1	Remove all power from all equipment. <div style="border: 1px solid black; padding: 5px; margin-top: 10px;"> <p style="text-align: center;"> DANGER</p> <p>HAZARD OF ELECTRIC SHOCK, EXPLOSION OR ARC FLASH</p> <ul style="list-style-type: none"> Disconnect all power from all equipment including connected devices prior to removing any covers or doors, or installing or removing any accessories, hardware, cables, or wires except under the specific conditions specified in the appropriate hardware guide for this equipment. Always use a properly rated voltage sensing device to confirm the power is off where and when indicated. Replace and secure all covers, accessories, hardware, cables, and wires and confirm that a proper ground connection exists before applying power to the unit. Use only the specified voltage when operating this equipment and any associated products. <p>Failure to follow these instructions will result in death or serious injury.</p> </div>
2	Remove the Cluster Termination. To do this, refer to Removing a Cluster Termination from the DIN Rail, page 80.
3	Remove the terminal blocks from each module. To do this, refer to Removing a Terminal Block from a Module, page 76.
4	Starting from the rightmost module, remove the Modicon Edge I/O module kits one after another from the DIN rail. To do this, refer to Removing a Kit from the DIN Rail, page 73.

Partial Configuration Removal

The following procedure describes how to partially remove a configuration:

Step	Action
1	<p>Remove all power from all equipment.</p> <div style="background-color: black; color: white; text-align: center; padding: 5px;">  DANGER </div> <p>HAZARD OF ELECTRIC SHOCK, EXPLOSION OR ARC FLASH</p> <ul style="list-style-type: none"> Disconnect all power from all equipment including connected devices prior to removing any covers or doors, or installing or removing any accessories, hardware, cables, or wires except under the specific conditions specified in the appropriate hardware guide for this equipment. Always use a properly rated voltage sensing device to confirm the power is off where and when indicated. Replace and secure all covers, accessories, hardware, cables, and wires and confirm that a proper ground connection exists before applying power to the unit. Use only the specified voltage when operating this equipment and any associated products. <p>Failure to follow these instructions will result in death or serious injury.</p>
2	<p>Remove the Cluster Termination. To do this, refer to Removing a Cluster Termination from the DIN Rail, page 80.</p>
3	<p>Remove the terminal blocks from each module to be removed. To do this, refer to Removing a Terminal Block from a Module, page 76.</p>
4	<p>Slide the module kits on the right of the module to be removed.</p>
5	<p>Remove the Modicon Edge I/O module kit from the DIN rail. To do this, refer to Removing a Kit from the DIN Rail, page 73.</p>
6	<p>Slide back the modules to the left until it clicks into place on the previously installed module.</p>
7	<p>Mount the Cluster Termination. To do this, refer to Mounting a Cluster Termination on the DIN Rail, page 80.</p>

Coding the Modicon Edge I/O NTS

What's in This Chapter

Overview	83
Creating a Coding Scheme	84
How to Install the Coding Keys	84

Overview

Use coding keys and labeling tools to associate terminal blocks, modules and base plates, which can help minimize mounting and maintenance errors.

The following illustrations present how the coding keys create a mechanical interference between the terminal block and the module:

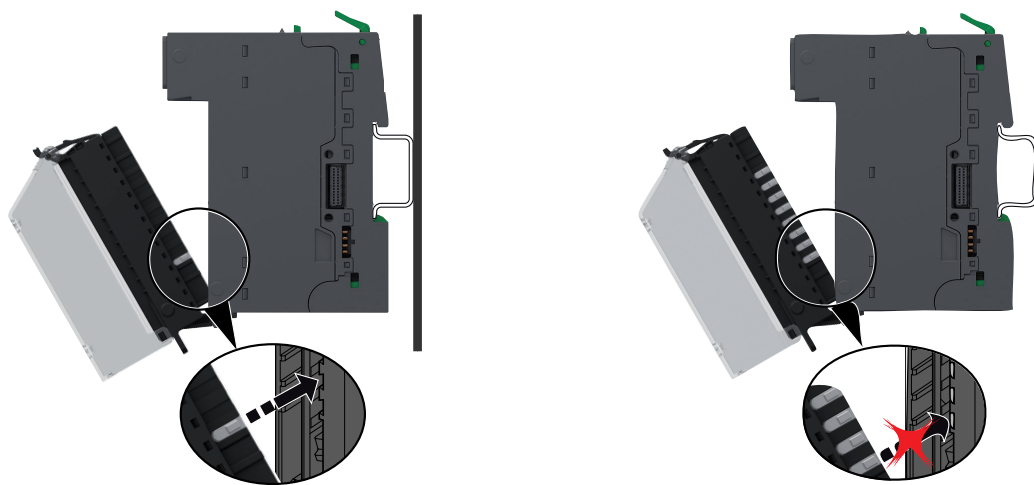

The following illustration presents the location of the coding key slots on a power supply terminal block:

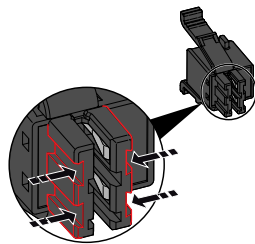

NOTE: Use coding keys to avoid mismatches between the 24 Vdc field power (CN1) and 24 Vdc bus (CN2) terminal blocks on the Power supply Field and Bus module.

The following illustrations present the location of the coding key slots on the back of a module and on a base plate:

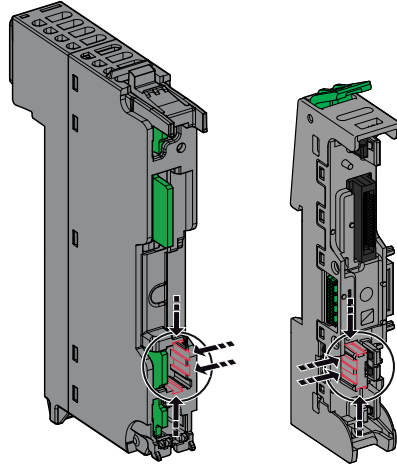

Creating a Coding Scheme

There are several coding schemes available in a Modicon Edge I/O NTS cluster, such as:

- Assigning different codes to the top and bottom module connections.
- Using different codes for adjacent modules.

The number of available keys varies with your terminal block and base plate:

Module		Number of keys
I/O Terminal blocks	12 points	8
	18 points	9
Power supply terminal blocks		4
Base plate		6

How to Install the Coding Keys

To key a module and a terminal block, use the NTSXMP1000 keying kit. It comes with ten pinwheels. Each pinwheel has a set of 8 keys that can be pushed into the desired key slots on the module according to your keying scheme.

Labeling the Module

Each individual module has a reserved space for the NTSXMP2000 marking label kit, page 35.

Label dimension: 14 x 10 mm (0.55 x 0.4 in)

Marking labels can help you identify information on individual modules.

The following illustration indicates where NTSXMP2000 labels fit on the module:

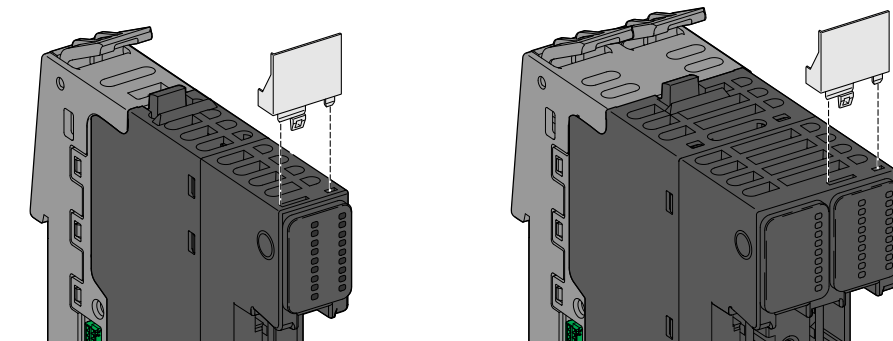

Plain Text Installation on Clear Cover

The clear cover of the Terminal Blocks, page 132 has a dedicated space that allows you to insert a paper label:

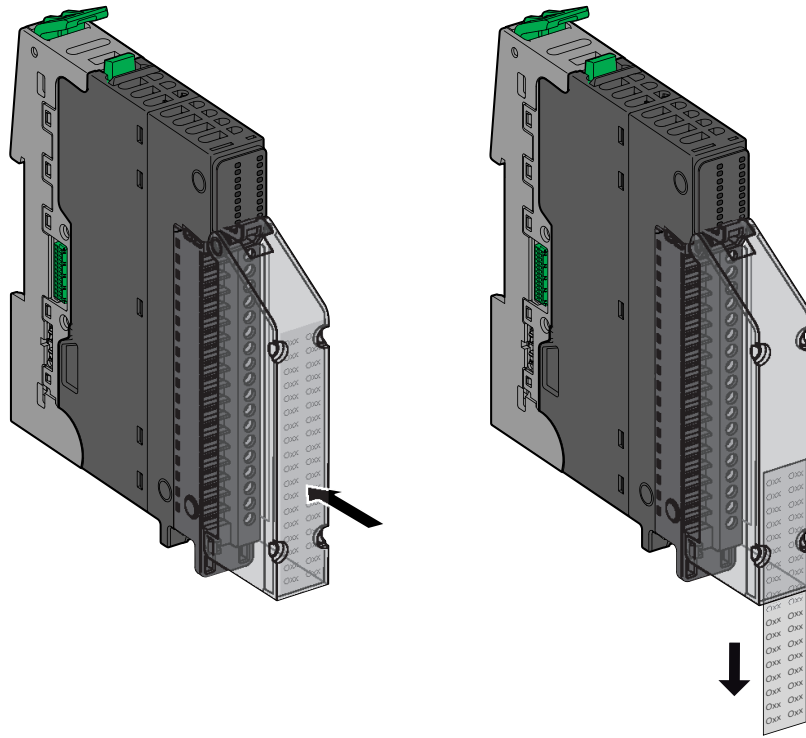

The label size depends on the height of the module:

Module height	Label dimensions
100 mm (3.93 in.)	65 x 10.7 mm (2.56 x 0.42 in.)
121 mm (4.76 in.)	86 x 10.7 mm (3.38 x 0.42 in.)

Maintaining and Diagnosing

What's in This Part

Maintenance	88
Diagnostics	89
Hot Swapping Electronic Modules	91

Maintenance

What's in This Chapter

Maintenance Plan	88
------------------------	----

Maintenance Plan

Prior to any type of work on the system, establish a maintenance plan matching the information, the precautions and the processes observed in this manual.

Include the following points in the maintenance plan of your machine:

- Inspect the product for pollution or damage at regular intervals.
- Inspect all connection cables and connectors regularly for damage. Replace damaged cables immediately.
- Verify that all input and output elements are firmly seated.
- Tighten all mechanical and electrical threaded connections to the specified torque.

Diagnostics

What's in This Chapter

Test Probes	89
Diagnostics Status LEDs.....	89
Modicon Edge I/O Configurator Software	89
Modicon Edge I/O Web Interface	90

Test Probes

The Terminal Blocks, page 132 have an access point for a test probe. You can measure the terminal potential without disconnecting the wire.

The following figure presents the use of the test probes:

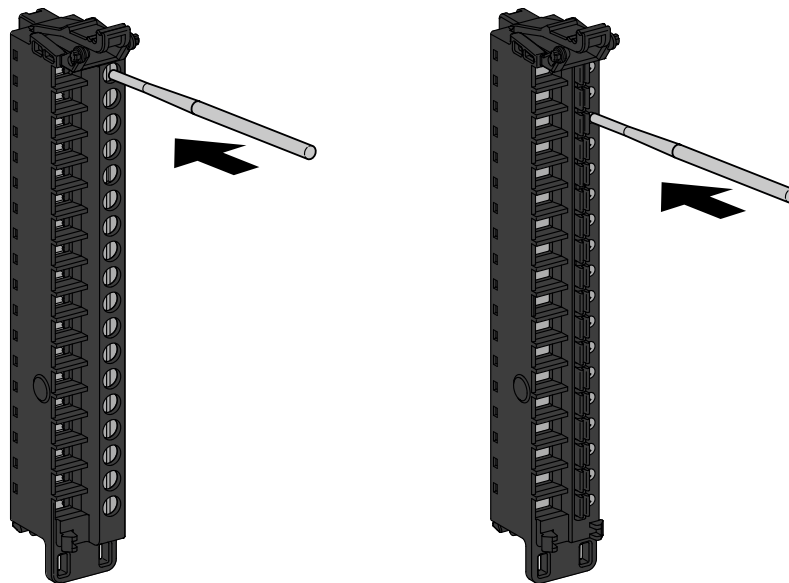

Diagnostics Status LEDs

Modicon Edge I/O 24 Vdc bus status, 24 Vdc field power, I/O status and channel states are displayed in direct relationship to the channels or the function.

Various states are displayed in different ways; for example, green signifies "OK" while red indicates a detected error.

Refer to the user guides of the Modicon Edge I/O modules for status LEDs descriptions.

Modicon Edge I/O Configurator Software

You can use the Modicon Edge I/O Configurator software for module configuration and control as well as application diagnostics and monitoring.

For more information about the Modicon Edge I/O Configurator, refer to the Modicon Edge I/O - Configurator and Web Interface - User Guide.

Modicon Edge I/O Web Interface

The network interface module provides as standard equipment an embedded Web interface with a predefined factory built-in website.

You can use the pages of the website for module setup and control as well as application diagnostics and monitoring.

For more information about the web interface, refer to the Modicon Edge I/O - Configurator and Web Interface - User Guide.

NOTE: Schneider Electric adheres to industry best practices in the development and implementation of control systems. This includes a "Defense-in-Depth" approach to secure an Industrial Control System. This approach places the controllers behind one or more firewalls to restrict access to authorized personnel and protocols only.

⚠ WARNING

UNAUTHENTICATED ACCESS AND SUBSEQUENT UNAUTHORIZED MACHINE OPERATION

- Evaluate whether your application environments are connected to your critical infrastructure and, if so, take appropriate steps in terms of prevention, based on Defense-in-Depth, before connecting the automation system to any network.
- Limit the number of devices connected to a network to the minimum necessary.
- Isolate your industrial network from other networks inside your company.
- Protect any network against unintended access by using firewalls, VPN, or other, proven security measures, such as an Intrusion Prevention System or Intrusion Detection System.
- Monitor activities within your systems.
- Prevent subject devices from direct access or direct link by unauthorized parties or unauthenticated actions.
- Install certificates that are issued by publicly known Trusted Certificate Authorities.
- Keep your systems up-to-date and rely only on legitimate sources.
- Prepare a recovery plan including backup of your system and process information.

Failure to follow these instructions can result in death, serious injury, or equipment damage.

For more information on organizational measures and rules covering access to infrastructures, refer to ISO/IEC 27000 series, Common Criteria for Information Technology Security Evaluation, ISO/IEC 15408, IEC 62351, ISA/IEC 62443, NIST Cybersecurity Framework, Information Security Forum - Standard of Good Practice for Information Security and refer to [Cybersecurity Best Practices](#).

Hot Swapping Electronic Modules

What's in This Chapter

Overview	91
Hot Swapping Considerations	91
Elements That Cannot Be Hot Swapped	93
Hot Swap Procedure	93

Overview

Hot swapping enables the removal and replacement of an I/O module with an identical one while power remains applied to the system, without disrupting cluster operations. Upon reinsertion or replacement with a module of the same reference, the I/O module resumes operation.

Subsequently, power is reapplied to the module upon insertion to its base and is automatically reconfigured.

Hot Swapping Considerations

Before initiating a hot swap operation, confirm that the module type is approved for hot swapping. See the [hot swapping procedure](#), page 93 for more details.

- Confirm that the extension module type is approved for hot swapping.
- Hot swapping is only allowed for one module at a given time. You must use a dummy module to fill an empty base before initiating a new hot swap operation.
- Removing a module from its base, during operation, should not last longer than the amount of time required to hot swap a module. If you must leave the base empty for an extended period, install a dummy module in the empty base.
- While power is applied, remove and insert by hand. Do not use tools to hot swap modules because they may come into contact with hazardous voltages.
- For all I/O modules for which the voltage is above the Safety Extra Low Voltage (SELV), only perform hot swap operations when the power supply is disconnected.
- Hot swapping is only allowed when replacing identical modules.
- Only the module is hot swappable. Do not attempt a hot swap operation on the base.
- Wait for a minimum of five seconds between two hot swap operations.
- Ensure that you thoroughly understand the effects of a hot swap operation on all modules and connected devices as they relate to your machine or process.

DANGER

EXPLOSION OR ELECTRIC SHOCK

- Only perform a hot swap operation in locations known and confirmed to be non-hazardous.
- Use only your hands.
- Do not use any metal tools.
- Do not disconnect any wires from the terminal block.
- Only replace a module with an identical reference.
- Disconnect power supply if the I/O module voltage is above SELV.

Failure to follow these instructions will result in death or serious injury.

▲ WARNING**UNINTENDED EQUIPMENT OPERATION**

- Do not attempt a hot swap operation on the base.
- Confirm that the module type is approved for hot swapping.
- Do not leave a base empty for an extended period of time.

Failure to follow these instructions can result in death, serious injury, or equipment damage.

NOTICE**COMMUNICATION INTERRUPTION**

Insert a dummy module into any empty bases before attempting a hot swap operation on another module.

Failure to follow these instructions can result in equipment damage.

NOTICE**INOPERABLE EQUIPMENT**

- Remove the electronic module from the base before removing the terminal block.
- Do not perform two consecutive connections of the module during the hot swap operations in less than five seconds.

Failure to follow these instructions can result in equipment damage.

You must understand and plan for the effects of hot swapping certain modules. Hot swapping modules can impact your machine or process.

For example, an I/O configuration that employs common distribution modules requires careful consideration when wiring is restricted by short wire lengths. It may be the case that in order to hot swap a module that has become inoperable, you must disconnect the connector of the common module servicing it.

Further, that same common module may be connected to modules or devices other than the module you wish to hot swap. Disconnecting the common module in this case would necessarily interrupt the supply to the unaffected modules and/or devices.

Verify which I/O modules or devices are connected to the common module, and the impact that this disconnection would have on your machine or process before attempting a hot swap operation.

Elements That Cannot Be Hot Swapped

The following table explains why some of the Modicon Edge I/O NTS elements cannot be hot swapped:

Element	Reason
All network interface modules	The replacement of a network interface module requires: <ul style="list-style-type: none"> • A power cycle to complete initialization. • Network interface modules with identical firmware version.
All bases and cluster terminations	The replacement of a base or a cluster termination requires a power cycle.
All PFB modules	Removing the PFB module de-energizes the 24 Vdc bus power. Inserting the PFB module requires the system to be initialized.

Hot Swap Procedure

Follow this procedure to perform a hot swap operation:

Step	Action
1	Read and understand the Hot Swapping Considerations, page 91.
2	Remove the module with the terminal block from the base, refer to Removing a Module from a Base, page 71
3	Remove the terminal block from the module. Refer to Removing a Terminal Block from a Module, page 76
4	Mount the terminal block on a module with an identical reference, refer to Mounting a Terminal Block on a Module, page 74
5	Mount the module with the terminal block on the base, refer to Mounting a Module on a Base, page 70

Modules and Accessories

What's in This Part

Power Supply Modules	95
Common Distribution Modules.....	107
Spare Bases	128
Terminal Blocks	132
Dummy Modules	142
Cluster Termination	148

Power Supply Modules

What's in This Chapter

NTSPFB1002H Power Supply Module, 24 Vdc, Field and Bus, Hardened	96
NTSPFD1002H Power Supply Module, 24 Vdc, Field, Hardened	101



NTSPFB1002H Power Supply Module, 24 Vdc, Field and Bus, Hardened

NTSPFB1002H Presentation

Overview

The NTSPFB1002H is a standard hardened Power supply Field and Bus module.

The second component in the configurations of a Modicon Edge I/O cluster is always a Power supply Field and Bus (PFB), page 33.

The Power supply Field and Bus distributes power to:

- The network interface module
- The 24 Vdc bus
- The 24 Vdc field power

Main Characteristics

The following table describes the main characteristics of the Modicon Edge I/O NTS NTSPFB1002H power supply module:

Main Characteristics	Range
Maximum current provided on the 24 Vdc bus	3.5 A
Maximum current provided on a 24 Vdc field power segment	10.5 A

For more information about the power distribution on a Modicon Edge I/O NTS island, refer to Modicon Edge I/O NTS Power Distribution, page 46.

Purchasing Information

The following figure shows the elements of the Modicon Edge I/O NTS NTSPFB1002H power supply module:

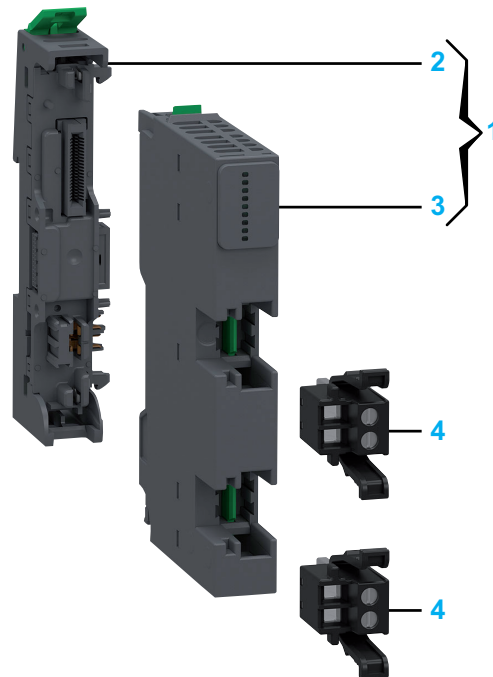

Number	Reference	Description
1	NTSPFB1002HK	Base + Module (kit) NOTE: The module and its corresponding base can be purchased as a kit.
2	NTSXBA0103H	Spare Base, 1 Slot, for Power Supply Field and Bus Module, Hardened
3	NTSPFB1002H	Power Supply Module, 24 Vdc, Field and Bus, Hardened
4	NTSXTB02030H NTSXTB02230H	Screw Terminal Block, 2 Points, 5 mm Pitch, use on Power Supply Module, Hardened Spring Terminal Block, 2 Points, 5 mm Pitch, use on Power Supply Module, Hardened NOTE: The terminal blocks are purchased separately.

NOTE: For more information on accessories and spare parts, refer to Modicon Edge I/O NTS Accessories, page 34.

Physical Description

The following figure presents the elements of the module:

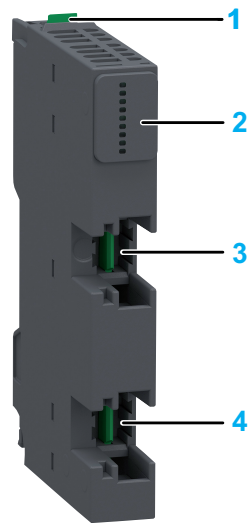

- 1: Release button for disengaging the module from the base
- 2: Status LEDs
- 3: Slot for the terminal block dedicated to the bus power supply
- 4: Slot for the terminal block dedicated to the field power supply

Status LEDs

The following figure presents the NTSPFB1002H status LEDs:

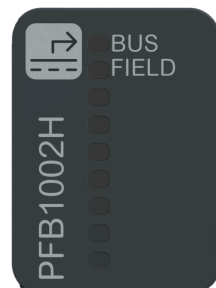

The following table describes the status of LEDs:

BUS (Green)	FIELD (Green)	Description
OFF	-	Indicates either: <ul style="list-style-type: none"> • The 24 Vdc bus is not energized. • The module has detected an error and is in shutdown.
ON	-	24 Vdc bus is energized.
-	OFF	Indicates either: <ul style="list-style-type: none"> • The 24 Vdc field power is not energized. • The module has detected an error and is in shutdown. • The 24 Vdc bus is not energized.
-	ON	Normal operation

NOTE: When in shutdown following the detection of an overload or short circuit error, the equipment must be power cycled after you have resolved the source of the error.

NTSPFB1002H Characteristics

Overview

This section provides a general description of the characteristics of the Power supply Field and Bus module.

⚠ WARNING

UNINTENDED EQUIPMENT OPERATION

Do not exceed any of the rated values specified in the environmental and electrical characteristics tables.

Failure to follow these instructions can result in death, serious injury, or equipment damage.

The environmental characteristics of the NTSPFB1002H are described in the section *Operating Environment*, page 37.

Dimensions

The following figure presents the external dimensions of the NTSPFB1002H assembled module:

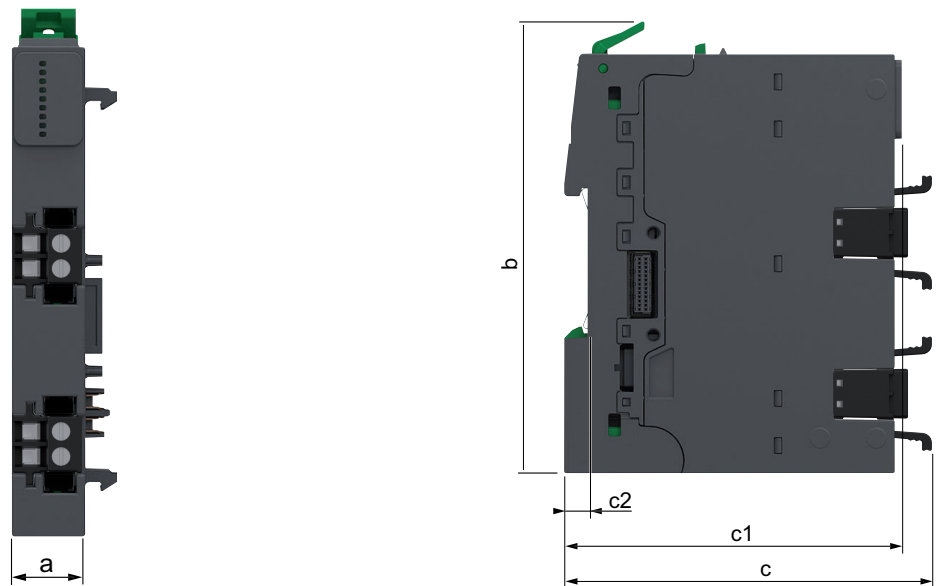

- a:** 15 mm (0.59 in)
- b:** 108.6 mm (4.27 in)
- c:** 87.2 mm (3.43 in)
- c1:** 80.7 mm (3.17 in)
- c2:** 5.6 mm (0.2 in)

Weight

- NTSPFB1002H: 49 g (1.73 oz)
- NTSPFB1002HK: 78 g (2.76 oz)

General Characteristics

The following table describes the general characteristics of the NTSPFB1002H module:

Characteristics	Value	
	24 Vdc bus	24 Vdc field power
Power supplied voltage range $\pm 5\%$ ripple	20.4...28.8 Vdc	
Nominal bus current consumption	3.1 mA	
Power Dissipation	1.56 W	
Maximum cable length	3 m	
Hot swap supported	No	
Reverse polarity protection	Yes	
Isolation between 24 Vdc bus and 24 Vdc field power	1,500 Vac	
Nominal operating current	3.5 A	10.5 A
Voltage surge protection	Yes	
Undervoltage protection	Yes, with hysteresis recovery.	
Overvoltage protection	Yes, with hysteresis recovery.	
Inrush current control	2 times the nominal current is permitted for 10 ms.	
Overload protection	Yes, with eFuse at 5.5 A	Yes with eFuse at 12.0 A
	During the first 20 ms the module is in power limitation mode, afterwards: <ul style="list-style-type: none"> • If the overload persists the module goes into shutdown. • If the overload recedes the module returns to normal operation. 	
Short circuit protection	Yes, at 11.0 A	Yes, at 24.0 A
	The module goes into shutdown $< 100 \mu\text{s}$ after a short circuit event.	
Power interruption hold-up time on bus	Continues normal operation for a minimum duration of 1 ms.	–

NOTE: When in shutdown following the detection of an overload or short circuit error, the equipment must be power cycled after you have resolved the source of the error.

NTSPFB1002H Wiring Diagram

The Power supply Field and Bus module is the first module of the distributed I/O configuration connected to an external 24 Vdc power supply.

The Power supply Field and Bus module requires two power supplies:

1. A 24 Vdc power supply to supply power to the 24 Vdc bus.
2. A 24 Vdc power supply to supply power to the first segment of the 24 Vdc field power.

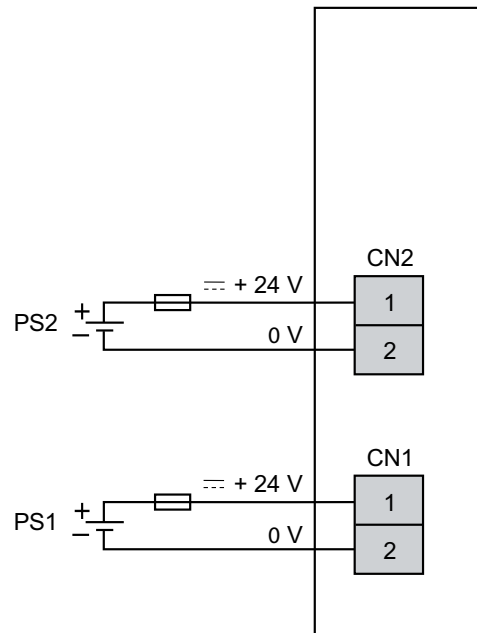

PS2 (CN2), PS1 (CN1): To select the power supply and external fuse, refer to Electrical Requirements, page 49.

NTSPFD1002H Power Supply Module, 24 Vdc, Field, Hardened

NTSPFD1002H Presentation

Overview

The NTSPFD1002H is a standard hardened Power supply Field Distribution module.

Where and when needed, the Power supply Field Distribution, page 33 (PFD) can be added to distribute the 24 Vdc over the 24 Vdc field power segment.

Main Characteristics

The following table describes the main characteristics of the Modicon Edge I/O NTS NTSPFD1002H power supply module:

Main Characteristics	Range
Maximum current provided on the 24 Vdc bus	0 A
Maximum current provided on a 24 Vdc field power segment	10.5 A

For more information about the power distribution on a Modicon Edge I/O NTS, refer to Modicon Edge I/O NTS Power Distribution, page 46.

Purchasing Information

The following figure shows the elements of the Modicon Edge I/O NTS NTSPFD1002H power supply module:

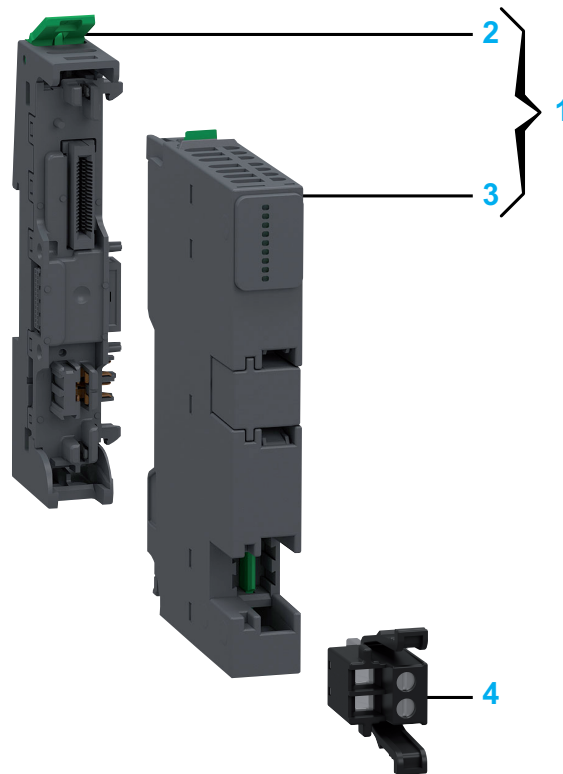

Number	Reference	Description
1	NTSPFD1002HK	Base + Module (kit) NOTE: The module and its corresponding base can be purchased as a kit.
2	NTSXBA0104H	Spare Base, 1 Slot, for Power Supply Field Distribution Module, Hardened
3	NTSPFD1002H	Power Supply Module, 24 Vdc, Field, Hardened
4	NTSXTB02030H NTSXTB02230H	Screw Terminal Block, 2 Points, 5 mm Pitch, use on Power Supply Module, Hardened Spring Terminal Block, 2 Points, 5 mm Pitch, use on Power Supply Module, Hardened NOTE: The terminal blocks are purchased separately.

NOTE: For more information on accessories and spare parts, refer to Modicon Edge I/O NTS Accessories, page 34.

Physical Description

The following figure presents the elements of the module:

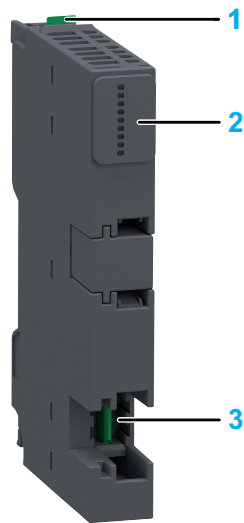

- 1: Release button for disengaging the module from the base
- 2: Status LEDs
- 3: Slot for the terminal block dedicated to the 24 Vdc field power supply

Status LEDs

The following figure presents the NTSPFD1002H status LEDs:

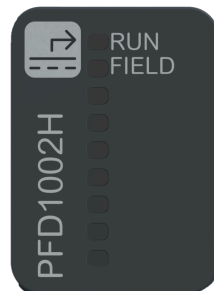

The following table describes the status of LEDs:

RUN (Green)	FIELD (Green)	Description
OFF	-	24 Vdc bus is not energized.
Regular Flash	-	24 Vdc bus is energized, but the module is not detected by the network interface module.
ON	-	24 Vdc bus is energized and the module is detected by the network interface module.
-	OFF	Indicates either: <ul style="list-style-type: none"> • The 24 Vdc field power is not energized. • The module has detected an error and is in shutdown. • The 24 Vdc bus is not energized.
-	ON	Normal operation.

NOTE: When in shutdown following the detection of an overload or short circuit error, the equipment must be power cycled after you have resolved the source of the error.

NTSPFD1002H Characteristics

Overview

This section provides a general description of the characteristics of the Power supply Field Distribution module.

⚠ WARNING

UNINTENDED EQUIPMENT OPERATION

Do not exceed any of the rated values specified in the environmental and electrical characteristics tables.

Failure to follow these instructions can result in death, serious injury, or equipment damage.

The environmental characteristics of the NTSPFD1002H are described in the section *Operating Environment*, page 37.

Dimensions

The following figure presents the external dimensions of the NTSPFD1002H assembled module:

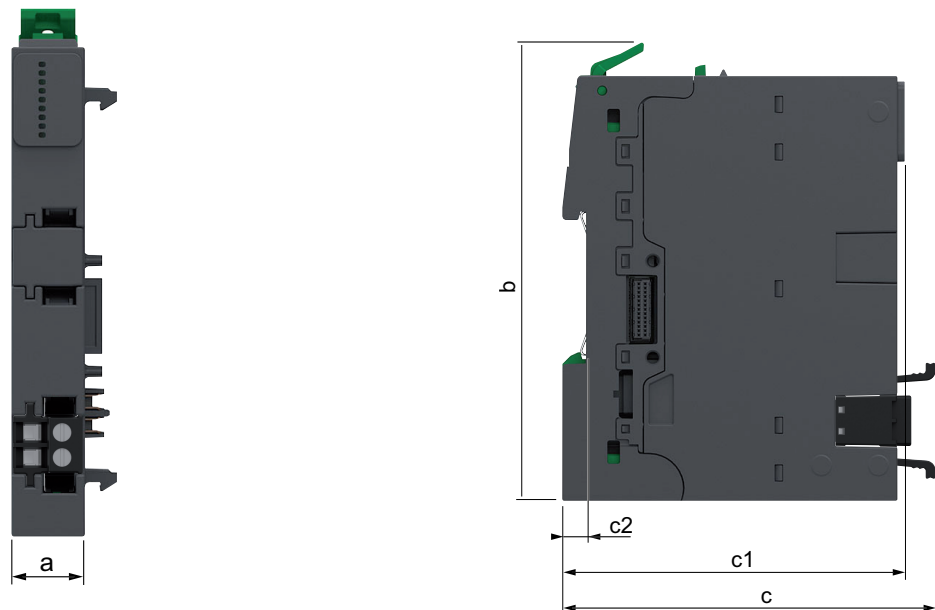

- a:** 15 mm (0.59 in)
- b:** 108.6 mm (4.27 in)
- c:** 87.2 mm (3.43 in)
- c1:** 80.7 mm (3.17 in)
- c2:** 5.6 mm (0.2 in)

Weight

- NTSPFD1002H: 51 g (1.8 oz)
- NTSPFD1002HK: 81 g (2.76 oz)

General Characteristics

The following table describes the general characteristics of the NTSPFD1002H module:

Characteristics	Value
Power supplied voltage range $\pm 5\%$ ripple	20.4...28.8 Vdc
Nominal bus current consumption	3 mA
Power Dissipation	1.31 W
Maximum cable length	3 m
Hot swap supported	Yes. De-energize the related 24 Vdc field power segment before the hot swap operation.
Reverse polarity protection	Yes
Isolation between 24 Vdc bus and 24 Vdc field power	1,500 Vac
Nominal operating current	10.5 A
Voltage surge protection	Yes
Undervoltage protection	Yes, with hysteresis recovery.
Overvoltage protection	Yes, with hysteresis recovery.
Inrush current control	2 times the nominal current is permitted for 10 ms.
Overload protection	Yes, with eFuse at 12.0 A During the first 20 ms the module is in power limitation mode, afterwards: <ul style="list-style-type: none"> • If the overload persists the module goes into shutdown. • If the overload recedes the module returns to normal operation.
Short circuit protection	Yes, at 24.0 A The module goes into shutdown $<100 \mu\text{s}$ after a short circuit event.

NOTE: When in shutdown following the detection of an overload or short circuit error, the equipment must be power cycled after you have resolved the source of the error.

NTSPFD1002H Wiring Diagram

Each Power supply Field Distribution module creates a separate 24 Vdc field power segment, which is supplied by an external 24 Vdc power supply.

Each Power supply Field Distribution module has its own 24 Vdc power supply connection.

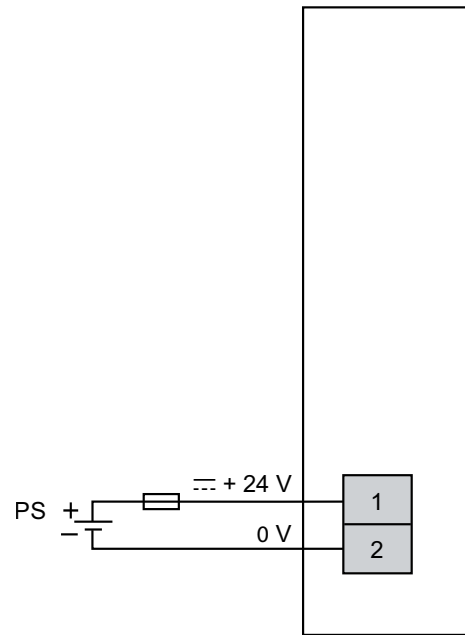

PS (CN1): To select the power supply and external fuse, refer to the Electrical Requirements, page 49

Common Distribution Modules

What's in This Chapter

NTSPCM0016H Common Distribution Module, 0 Vdc, 16 Points, Hardened 107

NTSPCM0808H Common Distribution Module, 0 Vdc, 8 Points, 24 Vdc, 8 Points, eFuse, Hardened 113

NTSPCM1600H Common Distribution Module, 24 Vdc, 16 Points, eFuse, Hardened 120

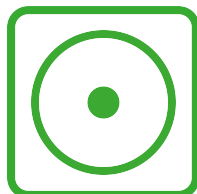

NTSPCM0016H Common Distribution Module, 0 Vdc, 16 Points, Hardened

NTSPCM0016H Presentation

Overview

The NTSPCM0016H common distribution module provides 16 x 0 Vdc terminal connections from the 24 Vdc field power segment, can be used for additional wiring for sensors and actuators.

Main Characteristics

The following table describes the main characteristics of the Modicon Edge I/O NTS NTSPCM0016H module:

Main Characteristics	Range	
Power supply source	From the 24 Vdc field power	
Type of common connections	0 Vdc	24 Vdc
Number of common connections	16	0

Purchasing Information

The following figure shows the elements of the Modicon Edge I/O NTS NTSPCM0016H common distribution module:

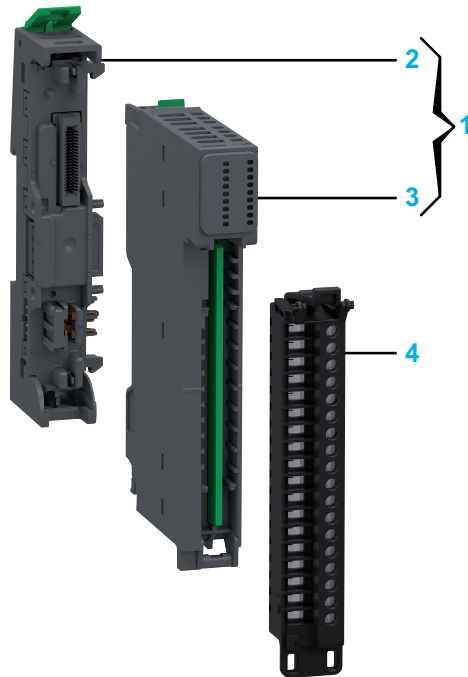

Number	Reference	Description
1	NTSPCM0016HK	Base + Module (kit) NOTE: The module and its corresponding base can be purchased as a kit.
2	NTSXBA0100H	Spare Base, 1 Slot, for Input/Output Common or Expert Module, Hardened
3	NTSPCM0016H	Common Distribution Module, 0 Vdc, 16 Points, Hardened
4	NTSXTB18000H	Screw Terminal Block, 18 Points, 3.81 mm Pitch, Without Cover, use on Low Height Module, Hardened
	NTSXTB18001H	Screw Terminal Block, 18 Points, 3.81 mm Pitch, With Cover, use on Low Height Module, Hardened
	NTSXTB18200H	Spring Terminal Block, 18 Points, 3.81 mm Pitch, Without Cover, use on Low Height Module, Hardened
	NTSXTB18201H	Spring Terminal Block, 18 Points, 3.81 mm Pitch, With Cover, use on Low Height Module, Hardened
		NOTE: The terminal blocks are purchased separately.

Physical Description

The following figure presents the elements of the module:

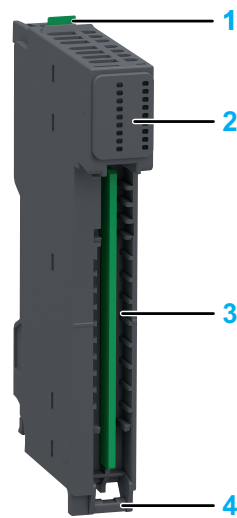

- 1: Release button for disengaging the module from the base
- 2: Status LED
- 3: Slot for the terminal block
- 4: Hinge for the terminal block installation

Status LEDs

The following figure presents the NTSPCM0016H status LED:

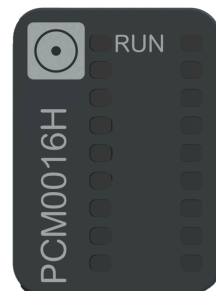

The following table describes the status of LED:

RUN (Green)	Description
OFF	24 Vdc bus is not energized.
Regular Flash	24 Vdc bus is energized but the module is not detected by the network interface module.
ON	24 Vdc bus is energized and the module is detected by the network interface module.

The following graphic depicts the system status of LEDs during module operation:

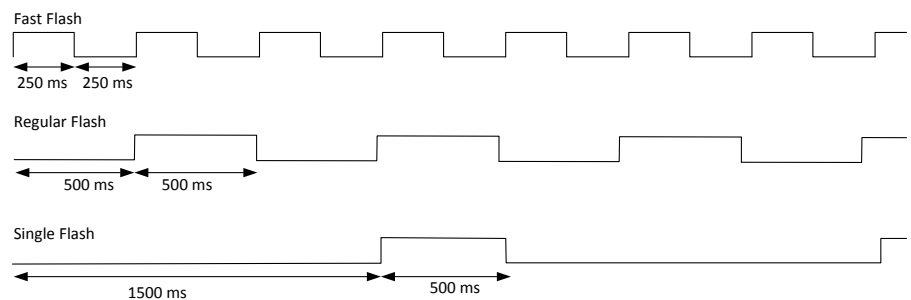

NTSPCM0016H Characteristics

Overview

This section provides a general description of the characteristics of the module.

⚠ WARNING

UNINTENDED EQUIPMENT OPERATION

Do not exceed any of the rated values specified in the environmental and electrical characteristics tables.

Failure to follow these instructions can result in death, serious injury, or equipment damage.

The environmental characteristics of the NTSPCM0016H are described in the section Operating Environment, page 37.

Dimension

The following figure presents the external dimensions of the assembled module:

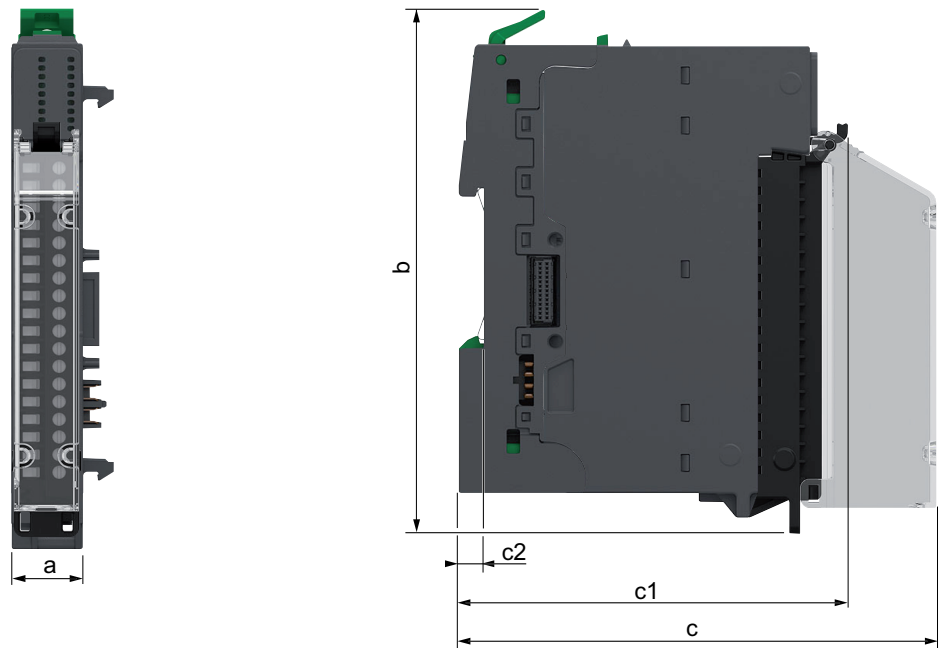

- a: 15 mm (0.59 in)
- b: 116.6 mm (4.57 in)
- c: 107.5 mm (4.21 in)
- c1: 88.2 mm (3.46 in)
- c2: 5.6 mm (0.2 in)

Weight

- NTSPCM0016H: 45 g (1.59 oz)
- NTSPCM0016HK: 72 g (2.54 oz)

Characteristics

The following tables describes the characteristics of the module:

Electrical Characteristics		Value
Power supplied voltage range		20.4...28.8 Vdc
Maximum operating current		10.5 A
Load temperature derating		No
Logic consumption	24 Vdc bus	3 mA
	24 Vdc field power	3 mA
Power Dissipation		0.59 W
Hot swap supported		Yes
Maximum permissible output cable length (per terminal)		200 m

NTSPCM0016H Wiring Diagram

Wiring Diagram

The following figure illustrates the connections for the NTSPCM0016H:

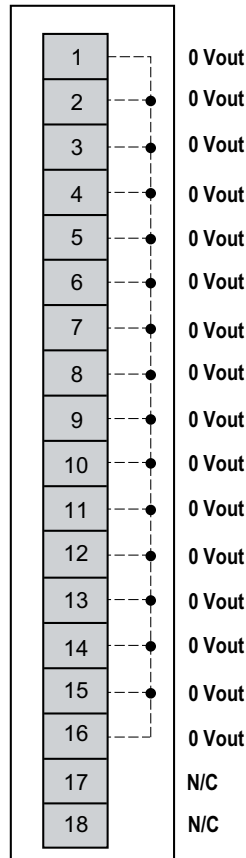

N/C: No Connection

⚠ WARNING
UNINTENDED EQUIPMENT OPERATION
Do not connect wires to unused terminals and/or terminals indicated as “No Connection (N/C)”.
Failure to follow these instructions can result in death, serious injury, or equipment damage.

NOTE: I/O modules and the field devices connected to the common module must all reside on the same 24 Vdc field power segment.

⚠ WARNING
POTENTIAL EXPLOSION OR FIRE
Connect the returns from the devices to the same power source as the 24 Vdc field power segment serving the module.
Failure to follow these instructions can result in death, serious injury, or equipment damage.

The following illustration presents an example for the NTSPCM0016H connections with a NTSDDI11602X:

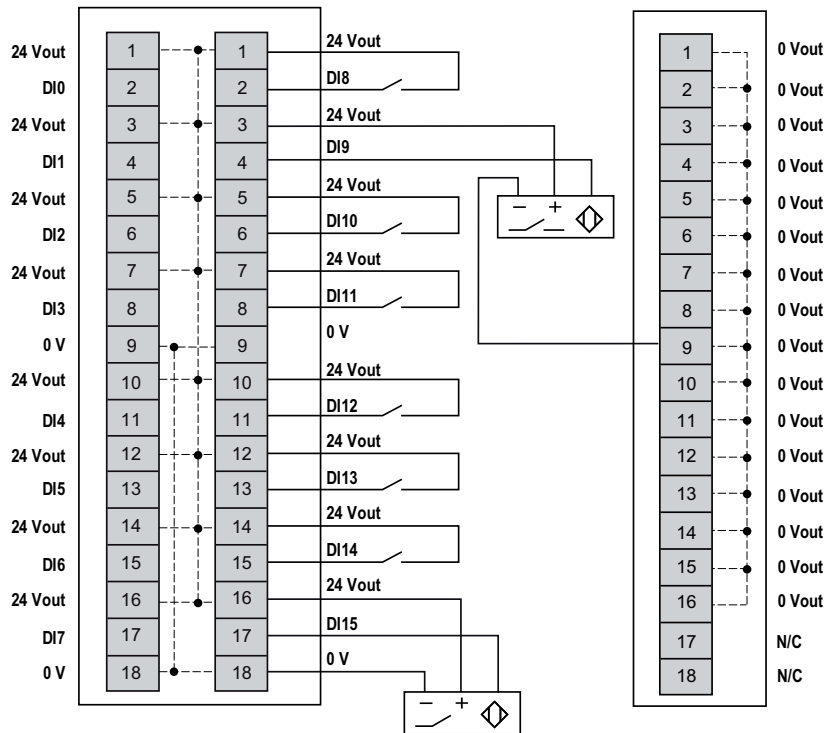

N/C: No Connection

⚠ WARNING
UNINTENDED EQUIPMENT OPERATION
Do not connect wires to unused terminals and/or terminals indicated as “No Connection (N/C)”.
Failure to follow these instructions can result in death, serious injury, or equipment damage.

NTSPCM0808H Common Distribution Module, 0 Vdc, 8 Points, 24 Vdc, 8 Points, eFuse, Hardened

NTSPCM0808H Presentation

Overview

The NTSPCM0808H common distribution module provides 8 x 0 Vdc and 8 x 24 Vdc terminal connections from the 24 Vdc field power segment, can be used for additional wiring for sensors and actuators.

Main Characteristics

The following table describes the main characteristics of the Modicon Edge I/O NTS NTSPCM0808H module:

Main Characteristics	Range	
Power supply source	From the 24 Vdc field power	
Type of common connections	0 Vdc	24 Vdc
Number of common connections	8	8

Purchasing Information

The following figure shows the elements of the Modicon Edge I/O NTS NTSPCM0808H common distribution module:

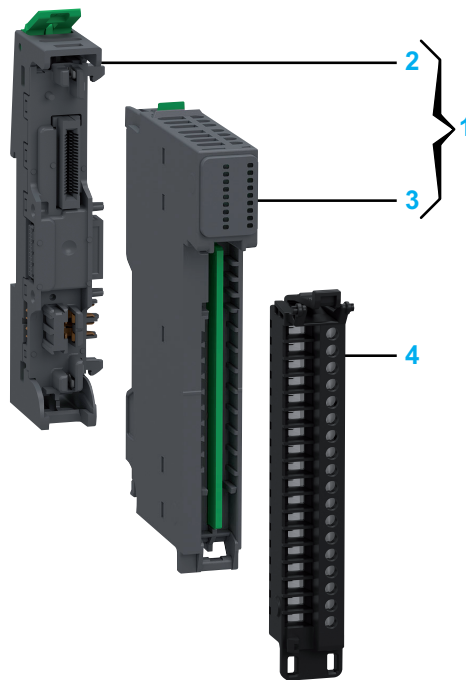

Number	Reference	Description
1	NTSPCM0808HK	Base + Module (kit) NOTE: The module and its corresponding base can be purchased as a kit.
2	NTSXBA0100H	Spare Base, 1 Slot, for Input/Output Common or Expert Module, Hardened
3	NTSPCM0808H	Common Distribution Module, 0 Vdc, 8 Points, 24 Vdc, 8 Points, eFuse, Hardened
4	NTSXTB18000H	Screw Terminal Block, 18 Points, 3.81 mm Pitch, Without Cover, use on Low Height Module, Hardened
	NTSXTB18001H	Screw Terminal Block, 18 Points, 3.81 mm Pitch, With Cover, use on Low Height Module, Hardened
	NTSXTB18200H	Spring Terminal Block, 18 Points, 3.81 mm Pitch, Without Cover, use on Low Height Module, Hardened
	NTSXTB18201H	Spring Terminal Block, 18 Points, 3.81 mm Pitch, With Cover, use on Low Height Module, Hardened
		NOTE: The terminal blocks are purchased separately.

Physical Description

The following figure presents the elements of the module:

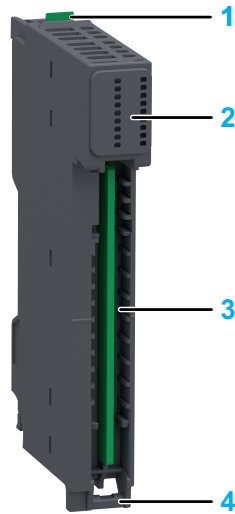

- 1: Release button for disengaging the module from the base
- 2: Status LEDs
- 3: Slot for the terminal block
- 4: Hinge for the terminal block installation

Status LEDs

The following figure presents the NTSPCM0808H status LEDs:

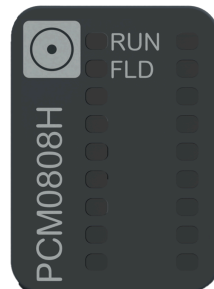

The following table describes the status of LEDs:

RUN (Green)	FLD (Green)	Description
OFF	-	24 Vdc bus is not energized.
Regular Flash	-	24 Vdc bus is energized but the module is not detected by the network interface module.
ON	-	24 Vdc bus is energized and the module is detected by the network interface module.
ON	OFF	Indicates: <ul style="list-style-type: none"> • The 24 Vdc pins of the NTSPCM0808H are not energized. • The module has detected an error and is in shutdown.
ON	ON	The 24 Vdc pins of the NTSPCM0808H are energized.

NOTE: When in shutdown following the detection of an overload or short circuit error, the equipment must be power cycled after you have resolved the source of the error.

The following graphic depicts the system status of LEDs during module operation:

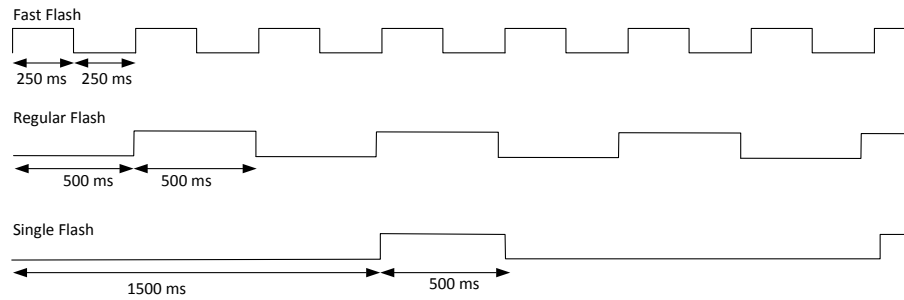

NTSPCM0808H Characteristics

Overview

This section provides a general description of the characteristics of the module.

⚠ WARNING

UNINTENDED EQUIPMENT OPERATION

Do not exceed any of the rated values specified in the environmental and electrical characteristics tables.

Failure to follow these instructions can result in death, serious injury, or equipment damage.

The environmental characteristics of the NTSPCM0808H are described in the section *Operating Environment*, page 37.

Dimension

The following figure presents the external dimensions of the assembled module:

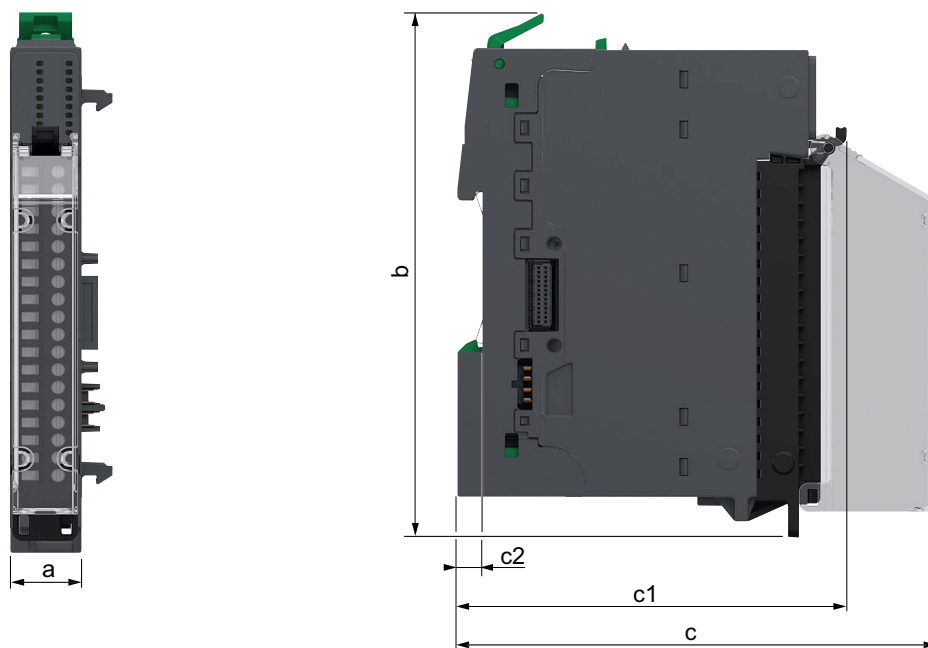

- a:** 15 mm (0.59 in)
- b:** 116.6 mm (4.57 in)
- c:** 107.5 mm (4.21 in)
- c1:** 88.2 mm (3.46 in)
- c2:** 5.6 mm (0.2 in)

Weight

- NTSPCM0808H: 48 g (1.7 oz)
- NTSPCM0808HK: 74 g (2.62 oz)

Characteristics

The following table describes the electrical characteristics of the module:

Electrical Characteristics		Value
Power supplied voltage range		20.4...28.8 Vdc
Maximum operating current		10.5 A on 24 Vdc field and 0 Vdc field
Load temperature derating		No
Logic consumption	24 Vdc bus	3 mA
	24 Vdc field power	3 mA
Power dissipation		1.43 W
Hot swap supported		Yes
Maximum permissible output cable length (per terminal)		200 m

The following table describes the input and output protection characteristics of the module:

Protection Characteristics	Value
Undervoltage protection	Yes, with hysteresis recovery.
Overvoltage protection	Yes, with hysteresis recovery.
Inrush current control	2 times the nominal current is permitted for 10 ms.
Power up limitation	Maximum 30 W for external devices
Overload protection	Yes, with eFuse at 12.0 A During the first 20 ms the module is in power limitation mode, afterwards: <ul style="list-style-type: none"> • If the overload persists the module goes into shutdown. • If the overload recedes the module returns to normal operation.
Short circuit protection	Yes, at 24.0 A The module goes into shutdown <100 μ s after a short circuit event.
Reverse polarity protection	Yes
PE Current	30 A for 2 minutes

NOTE: When in shutdown following the detection of an overload or short circuit error, the equipment must be power cycled after you have resolved the source of the error.

NTSPCM0808H Wiring Diagram

The following figure illustrates the connections for the NTSPCM0808H:

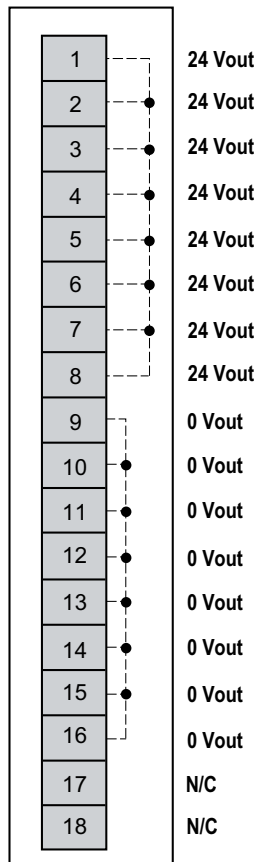

N/C: No Connection

⚠ WARNING
UNINTENDED EQUIPMENT OPERATION
Do not connect wires to unused terminals and/or terminals indicated as “No Connection (N/C)”.
Failure to follow these instructions can result in death, serious injury, or equipment damage.

The following figure illustrates an example for the NTSPCM0808H connections with a NTSDDI1602X and a NTSDDO0602:

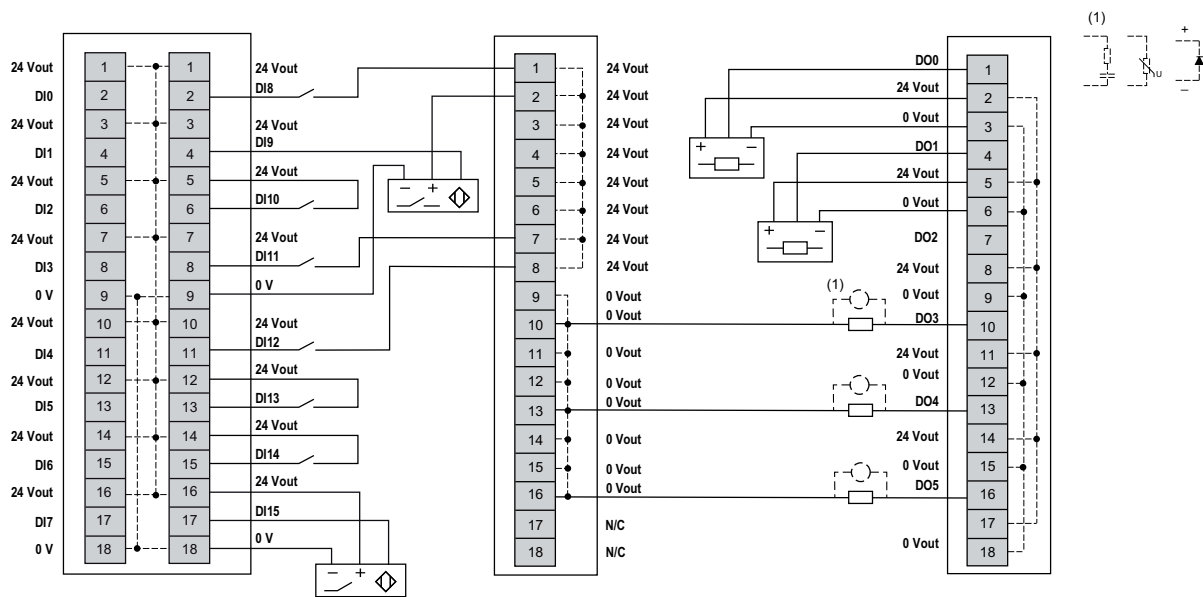

N/C: No Connection

⚠ WARNING

UNINTENDED EQUIPMENT OPERATION

Do not connect wires to unused terminals and/or terminals indicated as “No Connection (N/C)”.

Failure to follow these instructions can result in death, serious injury, or equipment damage.

NOTE: I/O modules and the field devices connected to the common module must all reside on the same 24 Vdc field power segment.

⚠ WARNING

POTENTIAL EXPLOSION OR FIRE

Connect the returns from the devices to the same power source as the 24 Vdc field power segment serving the module.

Failure to follow these instructions can result in death, serious injury, or equipment damage.

NTSPCM1600H Common Distribution Module, 24 Vdc, 16 Points, eFuse, Hardened

NTSPCM1600H Presentation

Overview

The NTSPCM1600H common distribution module provides 16 x 24 Vdc terminal connections from the 24 Vdc field power segment, can be used for additional wiring for sensors and actuators.

Main Characteristics

The following table describes the main characteristics of the Modicon Edge I/O NTS NTSPCM1600H module:

Main Characteristics	Range	
Power supply source	From the 24 Vdc field power	
Type of common connections	0 Vdc	24 Vdc
Number of common connections	0	16

Purchasing Information

The following figure shows the elements of the Modicon Edge I/O NTS NTSPCM1600H common distribution module:

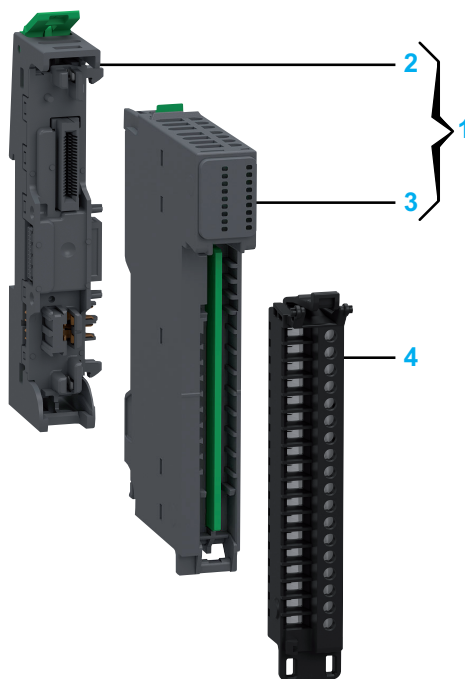

Number	Reference	Description
1	NTSPCM1600HK	Base + Module (kit) NOTE: The module and its corresponding base can be purchased as a kit.
2	NTSXBA0100H	Spare Base, 1 Slot, for Input/Output Common or Expert Module, Hardened
3	NTSPCM1600H	Common Distribution Module, 24 Vdc, 16 Points, eFuse, Hardened
4	NTSXTB18000H	Screw Terminal Block, 18 Points, 3.81 mm Pitch, Without Cover, use on Low Height Module, Hardened
	NTSXTB18001H	Screw Terminal Block, 18 Points, 3.81 mm Pitch, With Cover, use on Low Height Module, Hardened
	NTSXTB18200H	Spring Terminal Block, 18 Points, 3.81 mm Pitch, Without Cover, use on Low Height Module, Hardened
	NTSXTB18201H	Spring Terminal Block, 18 Points, 3.81 mm Pitch, With Cover, use on Low Height Module, Hardened
		NOTE: The terminal blocks are purchased separately.

Physical Description

The following figure presents the elements of the module:

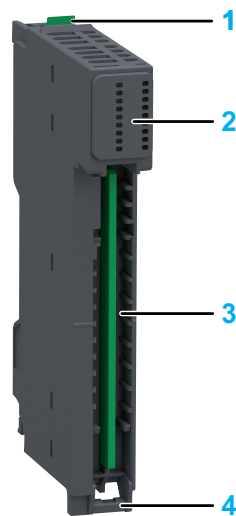

- 1: Release button for disengaging the module from the base
- 2: Status LEDs
- 3: Slot for the terminal block
- 4: Hinge for the terminal block installation

Status LEDs

The following figure presents the NTSPCM1600H status LEDs:

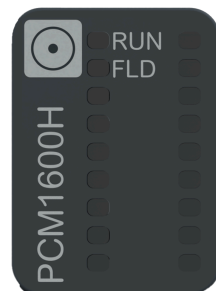

The following table describes the status of LEDs:

RUN (Green)	FLD (Green)	Description
OFF	-	24 Vdc bus is not energized.
Regular Flash	-	24 Vdc bus is energized but the module is not detected by the network interface module.
ON	-	24 Vdc bus is energized and the module is detected by the network interface module.
ON	OFF	Indicates: <ul style="list-style-type: none"> • The 24 Vdc pins of the NTSPCM1600H are not energized. • The module has detected an error and is in shutdown.
ON	ON	The 24 Vdc pins of the NTSPCM1600H are energized.

NOTE: When in shutdown following the detection of an overload or short circuit error, the equipment must be power cycled after you have resolved the source of the error.

The following graphic depicts the system status of LEDs during module operation:

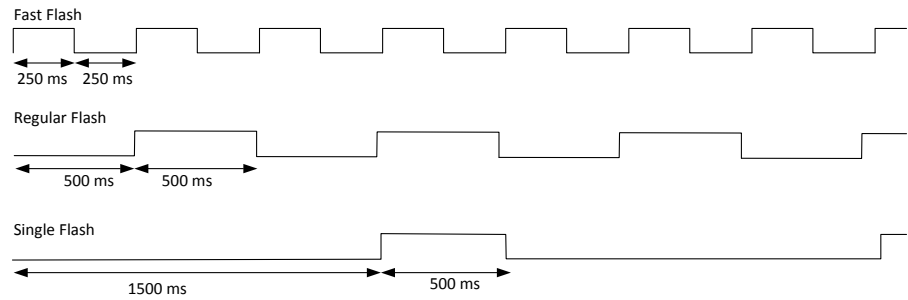

NTSPCM1600H Characteristics

Overview

This section provides a general description of the characteristics of the module.

▲ WARNING
UNINTENDED EQUIPMENT OPERATION
Do not exceed any of the rated values specified in the environmental and electrical characteristics tables.
Failure to follow these instructions can result in death, serious injury, or equipment damage.

The environmental characteristics of the NTSPCM1600H are described in the section *Operating Environment*, page 37.

Dimension

The following figure presents the external dimensions of the assembled module:

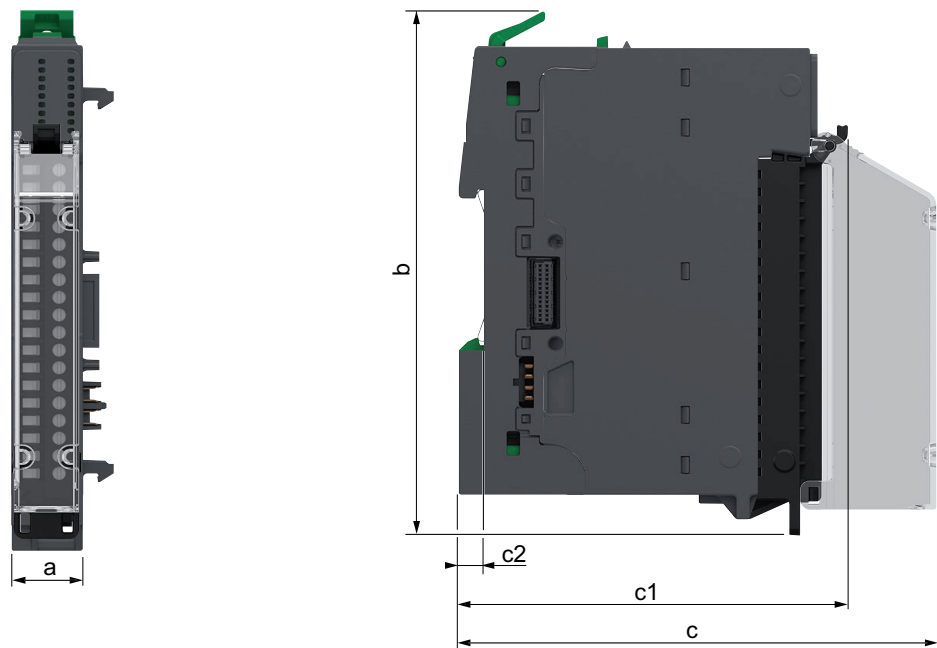

- a: 15 mm (0.59 in)
- b: 116.6 mm (4.57 in)
- c: 107.5 mm (4.21 in)
- c1: 88.2 mm (3.46 in)
- c2: 5.6 mm (0.2 in)

Weight

- NTSPCM1600H: 47 g (1.66 oz)
- NTSPCM1600HK: 74 g (2.62 oz)

Characteristics

The following table describes the electrical characteristics of the module:

Electrical Characteristics		Value
Power supplied voltage range		20.4...28.8 Vdc
Maximum operating current		10.5 A
Load temperature derating		No
Logic consumption	24 Vdc bus	3 mA
	24 Vdc field power	3 mA
Power Dissipation		1.35 W
Hot swap supported		Yes
Maximum permissible output cable length (per terminal)		200 m

The following table describes the input and output protection characteristics of the module:

Protection Characteristics	Value
Undervoltage protection	Yes, with hysteresis recovery.
Overvoltage protection	Yes, with hysteresis recovery.
Inrush current control	2 times the nominal current is permitted for 10 ms.
Power up limitation	Maximum 30 W for external devices
Overload protection	Yes, with eFuse at 12.0 A During the first 20 ms the module is in power limitation mode, afterwards: <ul style="list-style-type: none"> • If the overload persists the module goes into shutdown. • If the overload recedes the module returns to normal operation.
Short circuit protection	Yes, at 24.0 A The module goes into shutdown <100 μ s after a short circuit event.
Reverse polarity protection	Yes
PE Current	30 A for 2 minutes

NOTE: When in shutdown following the detection of an overload or short circuit error, the equipment must be power cycled after you have resolved the source of the error.

NTSPCM1600H Wiring Diagram

The following figure illustrates the connections for the NTSPCM1600H:

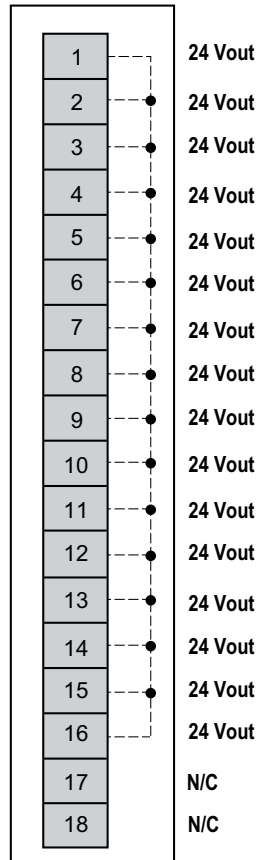

N/C: No Connection

⚠ WARNING
UNINTENDED EQUIPMENT OPERATION
Do not connect wires to unused terminals and/or terminals indicated as “No Connection (N/C)”.
Failure to follow these instructions can result in death, serious injury, or equipment damage.

The following figure illustrates an example for the NTSPCM1600H connections with a NTSDDI1602X:

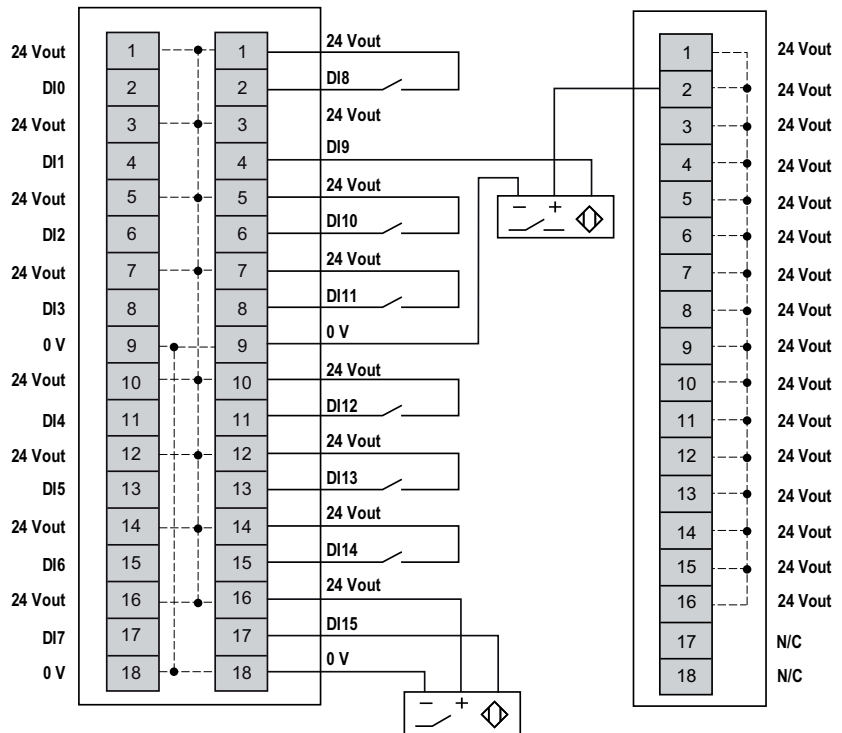

N/C: No connection

⚠ WARNING
UNINTENDED EQUIPMENT OPERATION
Do not connect wires to unused terminals and/or terminals indicated as “No Connection (N/C)”.
Failure to follow these instructions can result in death, serious injury, or equipment damage.

NOTE: I/O modules and the field devices connected to the common module must all reside on the same 24 Vdc field power segment.

⚠ WARNING
POTENTIAL EXPLOSION OR FIRE
Connect the returns from the devices to the same power source as the 24 Vdc field power segment serving the module.
Failure to follow these instructions can result in death, serious injury, or equipment damage.

Spare Bases

What's in This Chapter

Spare Bases Overview	128
Spare Bases NTSXBA•••0H	129
Spare Bases NTSXBA•••1H	130
Spare Bases NTSXBA•••3H	130
Spare Bases NTSXBA•••4H	131

Spare Bases Overview

The bases interconnected on the DIN rail form a structure that provides the physical connections for the I/O modules of the Modicon Edge I/O NTS cluster. This structure houses the I/O modules, supports the communications buses and provides power across the cluster.

A set of contacts on the side of the bases enables the modules to receive the 24 Vdc bus, the 24 Vdc field power, the auto-addressing signal, and bus communications.

There are four types of spare bases:

- The NTSXBA•••0H bases are designed to host Input/Output, Common, and Expert modules.
- The NTSXBA•••1H bases are designed to host the network interface modules.
- The NTSXBA•••3H bases are designed to host the Power supply Field and Bus modules.
- The NTSXBA•••4H bases are designed to host the Power supply Field Distribution modules.

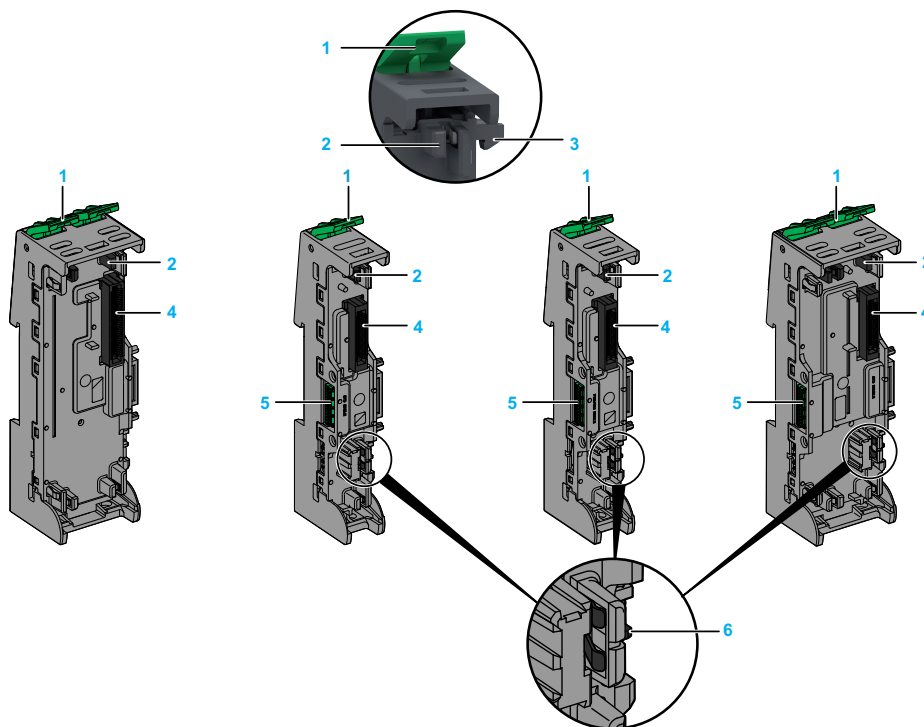

- 1: Locking lever.
- 2: Functional ground (FE) / direct connection to DIN rail through an earth contact.
- 3: Base to base fixing hook.
- 4: Module connector.
- 5: 24 Vdc bus connector.
- 6: 24 Vdc field power connector.

NOTE:

- Match specific bases with compatible module types and place the correct bases in the appropriate locations within the cluster.
- If there is a mechanical keying that prevents the installation of a module on a base, verify the configuration and that the module is intended for the base.
- Bases are designed to accommodate both hardened and standard modules.

⚠ DANGER

INCOMPATIBLE COMPONENTS CAUSE ELECTRIC SHOCK OR ARC FLASH



- Always confirm the compatibility of components before installation using the association table in this manual.
- Verify that correct terminal blocks are installed on the appropriate electronic modules

Failure to follow these instructions will result in death or serious injury.

Spare Bases NTSXBA...0H

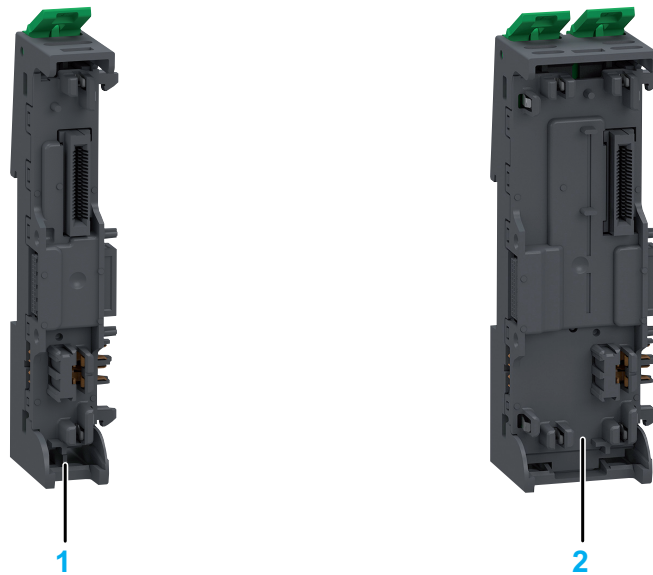
The following illustrations present the NTSXBA...0H bases which are designed to host Input/Output, Common, and Expert modules.





Number	Reference	Description
1	NTSXBA0100H 	Spare Base, 1 Slot, for Input/Output Common or Expert Module, Hardened
2	NTSXBA0200H 	Spare Base, 2 Slots, for Input/Output Common/Expert/Safety Module, Hardened

Spare Bases NTSXBA...1H

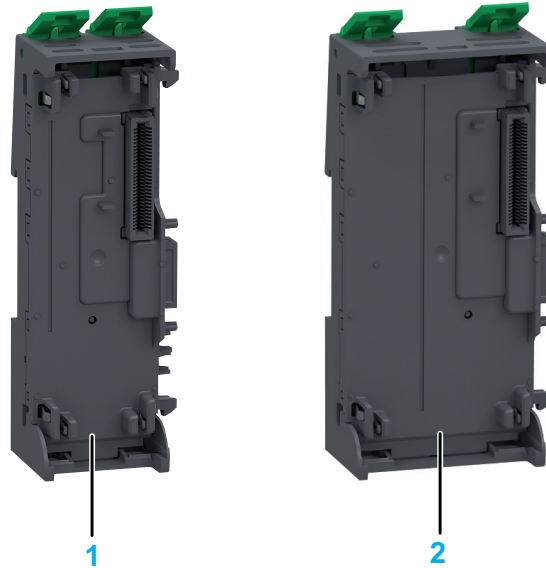
The following illustrations present the NTSXBA...1H bases that are designed to host the network interface modules.



Number	Reference	Description
1	NTSXBA0201H 	Spare Base, 2 Slots, for Network Interface or Bus Extender Module, Hardened
2	NTSXBA0301H 	Spare Base, 3 Slots, for Network Interface Module, Hardened

Spare Bases NTSXBA...3H

The following illustrations present the NTSXBA...3H bases which are designed to host the Power supply Field and Bus modules:

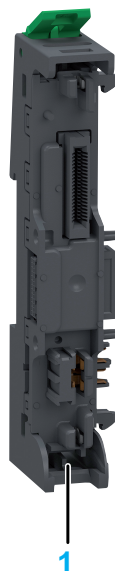

Number	Reference	Description
1	NTSXBA0103H 	Spare Base, 1 Slot, for Power Supply Field and Bus Module, Hardened

Spare Bases NTSXBA...4H

The following graphics show the NTSXBA...4H bases which are designed to host the Power Supply Field Distribution modules:



Number	Reference	Description
1	NTSXBA0104H 	Spare Base, 1 Slot, for Power Supply Field Distribution Module, Hardened

Terminal Blocks

What's in This Chapter

Terminal Blocks Overview 132
 Installing a Spare Clear Cover 134
 Terminal Blocks for DC Input/Output Modules 135
 Terminal Blocks for AC Input/Output Modules 138
 Terminal Blocks for Power Supply Modules 140

Terminal Blocks Overview

The following types of terminal blocks are available:

- The NTSXTB1••0•H and NTSXTB1••0•XH terminal blocks are designed for DC input/output modules.
- The NTSXTB12•1•H terminal blocks are designed for AC input/output modules.
- The NTSXTB02•30H terminal blocks are designed for power supply modules.

⚠ WARNING
UNINTENDED EQUIPMENT OPERATION
Do not exceed any of the rated values specified in the environmental and electrical characteristics tables.
Failure to follow these instructions can result in death, serious injury, or equipment damage.

The following illustrations present the features of the screw terminal block:

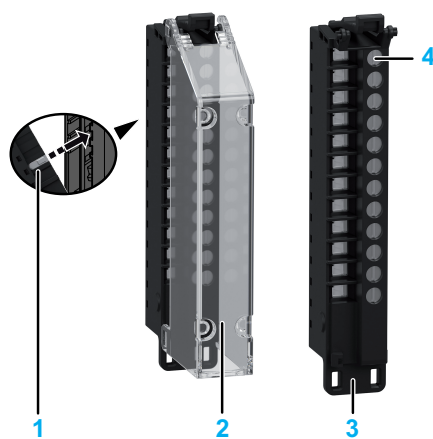

- 1: Coding key slots, page 83.
- 2: Plain text labeling, page 86 possible with a clear cover
- 3: Flange on terminal block to fix a cable tie to fasten cables.
- 4: Test access, page 89 for standard probes on the screw.

The following illustrations present the features of the spring terminal block:

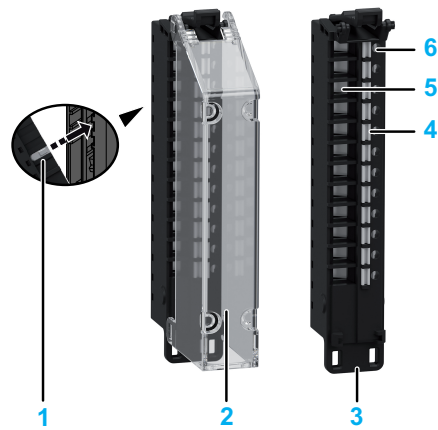

- 1: Coding key slots, page 83.
- 2: Plain text labeling, page 86 possible with a clear cover.
- 3: Flange on terminal block to fix a cable tie to fasten cables
- 4: Push-button wire release.
- 5: Tool-free wiring with spring clamp push-in technology.
- 6: Test access, page 89 for standard probes.

Installing a Spare Clear Cover

When purchased together, the terminal block and the clear cover come pre-assembled.

If you purchase a clear cover NTSXEM0000H or NTSXEM0000XH separately, follow these steps to install it on a terminal block:

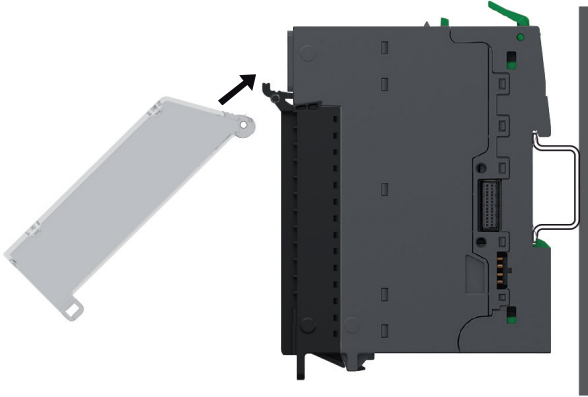
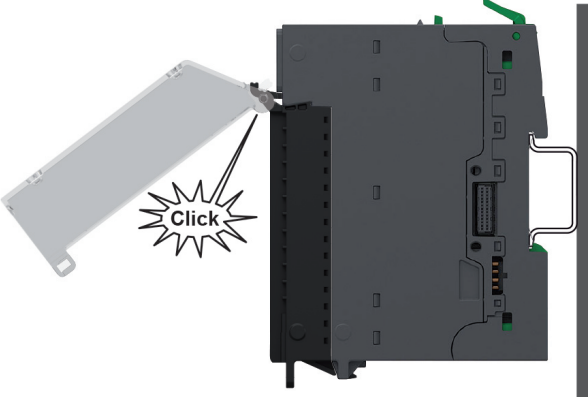
Step	Action
1	<p data-bbox="762 427 1380 477">Position the clear cover in front of the terminal block and align the hinge.</p>  <p>The diagram shows a grey terminal block with a black terminal strip on the left. A clear plastic cover is positioned to the left of the terminal strip. An arrow points from the top edge of the clear cover towards the top hinge of the terminal block, indicating the alignment step.</p>
2	<p data-bbox="762 987 1294 1014">Push the clear cover into the hinge until it clicks in place.</p>  <p>The diagram shows the clear cover being pushed into the hinge of the terminal block. A starburst graphic with the word 'Click' inside is positioned near the hinge, indicating that the cover is now properly seated.</p>

Terminal Blocks for DC Input/Output Modules

Overview

The following illustrations present the available terminal blocks for DC Input/Output modules:

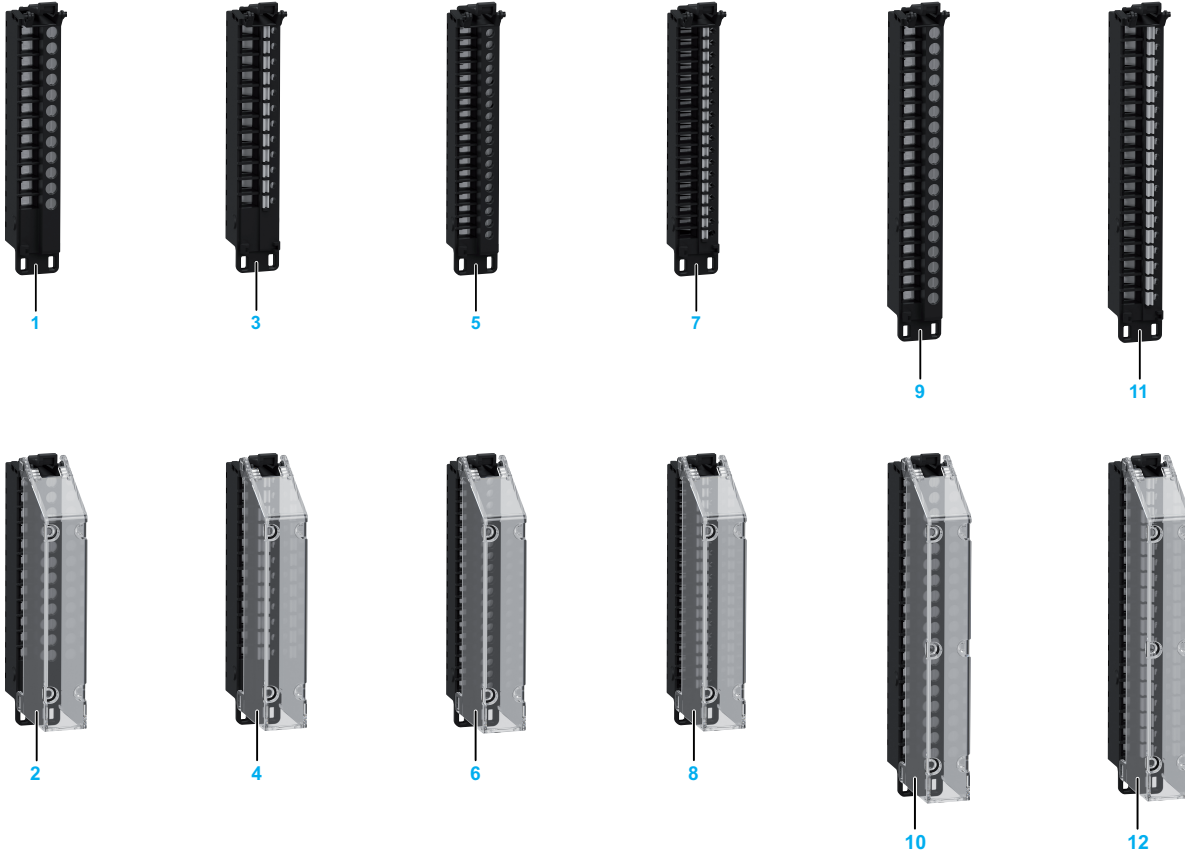

The following table describes the available terminal blocks for DC Input/Output modules:

Number	Reference	Description
1	NTSXTB12000H	Screw Terminal Block, 12 Points, 5 mm Pitch, Without Cover, use on Low Height Module, Hardened
2	NTSXTB12001H	Screw Terminal Block, 12 Points, 5 mm Pitch, With Cover, use on Low Height Module, Hardened
3	NTSXTB12200H	Spring Terminal Block, 12 Points, 5 mm Pitch, Without Cover, use on Low Height Module, Hardened
4	NTSXTB12201H	Spring Terminal Block, 12 Points, 5 mm Pitch, With Cover, use on Low Height Module, Hardened
5	NTSXTB18000H	Screw Terminal Block, 18 Points, 3.81 mm Pitch, Without Cover, use on Low Height Module, Hardened
6	NTSXTB18001H	Screw Terminal Block, 18 Points, 3.81 mm Pitch, With Cover, use on Low Height Module, Hardened
7	NTSXTB18200H	Spring Terminal Block, 18 Points, 3.81 mm Pitch, Without Cover, use on Low Height Module, Hardened
8	NTSXTB18201H	Spring Terminal Block, 18 Points, 3.81 mm Pitch, With Cover, use on Low Height Module, Hardened
9	NTSXTB18000XH	Screw Terminal Block, 18 Points, 5 mm Pitch, Without Cover, use on High Height Module (X), Hardened
10	NTSXTB18001XH	Screw Terminal Block, 18 Points, 5 mm Pitch, With Cover, use on High Height Module (X), Hardened

Number	Reference	Description
11	NTSXTB18200XH	Spring Terminal Block, 18 Points, 5 mm Pitch, Without Cover, use on High Height Module (X), Hardened
12	NTSXTB18201XH	Spring Terminal Block, 18 Points, 5 mm Pitch, With Cover, use on High Height Module (X), Hardened





Characteristics

The following table describes the characteristics of the terminal block:

Characteristics	Value		
Points	12	18	
Pitch (mm)	5.08	3.81	5.08
Contact resistance (mΩ)	< 2		
Maximum voltage	60 Vdc or 30 Vac	60 Vdc	
Maximum current per connector	For each position: 8 A Total cumulated positions: 56 A	For each position: 8 A Total cumulated positions: 32 A	For each position: 8 A Total cumulated positions: 56 A
Connection cross section	See Wire Size, page 136.		

Wire Size

The following table presents the connection cross section depending on the terminal block type:

Terminal block type							
	Screw/Spring	Screw	Spring		Screw/Spring	Screw/Spring	Screw/Spring
Pitch: 5.08 mm							
Connection cross section	mm ²	0.2...2.5	0.2...1.5	-	0.2...2.5	0.2...1.5	0.25...0.75
	AWG	24...14	24...16		24...14	24...16	24...20
Pitch: 3.81 mm							
Connection cross section	mm ²	0.13...1.5	0.13...1.0	-	0.13...1.5	0.13...1.0	0.25...0.75
	AWG	26...16	26...18		26...16	26...18	24...20

⚠ DANGER**FIRE HAZARD**

Use only the correct wire sizes for the maximum current capacity of the I/O channels and power supplies.

Failure to follow these instructions will result in death or serious injury.

The spring clamp connectors of the terminal block are designed for only one wire or one cable end. Two wires to the same connector must be installed with a double wire cable end to help prevent loosening.

⚠⚠ DANGER**LOOSE WIRING CAUSES ELECTRIC SHOCK**

Do not insert more than one wire per connector of the spring terminal blocks unless using a double wire cable end (ferrule).

Failure to follow these instructions will result in death or serious injury.

The following table presents the wiring specifications depending on the terminal block type:

Terminal Block Type	Screw	Spring
Wiring method	Captive screws usable with flat-tipped screwdriver with a diameter of 3.5 mm.	Wires are connected by pressing the button located next to each pin. To press the button, use a flat-tipped screwdriver with a maximum diameter of 3.5 mm.
Screw tightening torque	5 mm pitch: 0.4...0.5 Nm 3.81 mm pitch: 0.22...0.25 Nm	-
Stripping length	5 mm pitch: 10 mm 3.81 mm pitch: 8 mm	

Terminal Blocks for AC Input/Output Modules

Overview

The following illustrations present the available terminal blocks for AC Input/Output modules:

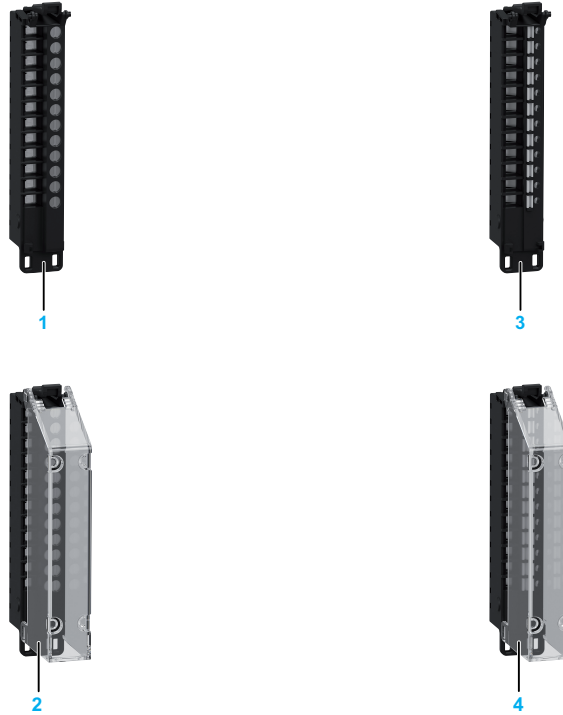

The following table describes the available terminal blocks for AC Input/Output modules:

Number	Reference	Description
1	NTSXTB12010H	Screw Terminal Block, 12 Points, 5 mm Pitch, Without Cover, AC, use on Low Height Module, Hardened
2	NTSXTB12011H	Screw Terminal Block, 12 Points, 5 mm Pitch, With Cover, AC, use on Low Height Module, Hardened
3	NTSXTB12210H	Spring Terminal Block, 12 Points, 5 mm Pitch, Without Cover, AC, use on Low Height Module, Hardened
4	NTSXTB12211H	Spring Terminal Block, 12 Points, 5 mm Pitch, With Cover, AC, use on Low Height Module, Hardened





Characteristics

The following table describes the characteristics of the terminal block:

Characteristics	Value	
Type of terminal	Screw	Spring
Pitch	5 mm	
Contact resistance	< 2 mΩ	
Maximum voltage	150 Vdc or 264 Vac	
Maximum current per connector	For each position: 8 A Total cumulated positions: 40 A	
Connection cross section	See Wire Size, page 139.	

Wire Size

The following table presents the connection cross section depending on the terminal block type:

Terminal block type							
		Screw/Spring	Screw	Spring	Screw/Spring	Screw/Spring	Screw/Spring
Connection cross section	mm ²	0.2...2.5	0.2...1.5	-	0.2...2.5	0.2...1.5	0.25...0.75
	AWG	24...14	24...16		24...14	24...16	24...20

DANGER

FIRE HAZARD

Use only the correct wire sizes for the maximum current capacity of the I/O channels and power supplies.

Failure to follow these instructions will result in death or serious injury.

The spring clamp connectors of the terminal block are designed for only one wire or one cable end. Two wires to the same connector must be installed with a double wire cable end to help prevent loosening.

DANGER

LOOSE WIRING CAUSES ELECTRIC SHOCK

Do not insert more than one wire per connector of the spring terminal blocks unless using a double wire cable end (ferrule).

Failure to follow these instructions will result in death or serious injury.

The following table presents the wiring specifications depending on the terminal block type:

Terminal Block Type	Screw	Spring
Wiring method	Captive screws usable with flat-tipped screwdriver with a diameter of 3.5 mm.	Wires are connected by pressing the button located next to each pin. To press the button, use a flat-tipped screwdriver with a maximum diameter of 3.5 mm.
Screw tightening torque	0.4...0.5 Nm	-
Stripping length	10 mm	

Terminal Blocks for Power Supply Modules

Overview

The following illustrations present the available terminal blocks for power supply modules:

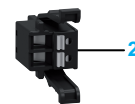
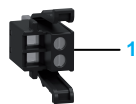

Number	Reference	Description
1	NTSXTB02030H	Screw Terminal Block, 2 Points, 5 mm Pitch, use on Power Supply Module, Hardened
2	NTSXTB02230H	Spring Terminal Block, 2 Points, 5 mm Pitch, use on Power Supply Module, Hardened





Characteristics

The following table describes the characteristics of the terminal block:

Characteristics	Value	
Points	2	
Type of terminal	Screw	Spring
Pitch	5 mm	
Contact resistance	< 2 mΩ	
Maximum voltage	30 Vdc	
Maximum current per connector	For each position: 10 A Total cumulated positions: 20 A	
Connection cross section	See Wire Size, page 141.	

Wire Size

The following table shows the connection cross section depending on the terminal block type:

Terminal block type							
		Screw/Spring	Screw	Spring	Screw/Spring	Screw/Spring	Screw/Spring
Connection cross section	mm ²	0.2...2.5	0.2...1.5	-	0.2...2.5	0.2...1.5	0.25...0.75
	AWG	24...14	24...16		24...14	24...16	24...20

DANGER

FIRE HAZARD

Use only the correct wire sizes for the maximum current capacity of the I/O channels and power supplies.

Failure to follow these instructions will result in death or serious injury.

The spring clamp connectors of the terminal block are designed for only one wire or one cable end. Two wires to the same connector must be installed with a double wire cable end to help prevent loosening.

DANGER

LOOSE WIRING CAUSES ELECTRIC SHOCK

Do not insert more than one wire per connector of the spring terminal blocks unless using a double wire cable end (ferrule).

Failure to follow these instructions will result in death or serious injury.

The following table presents the wiring constraints depending on the terminal block type:

Terminal Block Type	Screw	Spring
Wiring method	Captive screws usable with flat-tipped screwdriver with a diameter of 3.5 mm.	Wires are connected by pressing the button located next to each pin. To press the button, use a flat-tipped screwdriver with a maximum diameter of 3.5 mm.
Screw tightening torque	0.4...0.5 Nm	-
Stripping length	10 mm	

Dummy Modules

What's in This Chapter

NTSDMY0100H Dummy Module, Single Slot, Hardened	142
NTSDMY0200H Dummy Module, Double Slot, Hardened.....	144

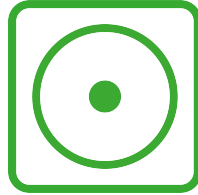

NTSDMY0100H Dummy Module, Single Slot, Hardened

Overview

The NTSDMY0100H is a non-functional module used as a placeholder for later system extension.

For more information on using a dummy module, refer to *The Layout of your Modicon Edge I/O NTS Island*, page 62.

Main Characteristics

The environmental characteristics of the NTSDMY0100H are described in the section *Operating Environment*, page 37.

⚠ WARNING

UNINTENDED EQUIPMENT OPERATION

Do not exceed any of the rated values specified in the environmental and electrical characteristics tables.

Failure to follow these instructions can result in death, serious injury, or equipment damage.

Purchasing Information

The following figure shows the elements of the Modicon Edge I/O NTS NTSDMY0100H dummy module:

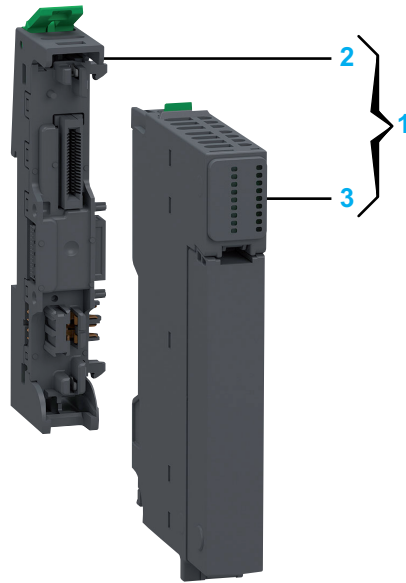

Number	Reference	Description
1	NTSDMY0100HK	Base + Module (kit) NOTE: The module and its corresponding base can be purchased as a kit.
2	NTSXBA0100H	Spare Base, 1 Slot, for Input/Output Common or Expert Module, Hardened
3	NTSDMY0100H	Dummy Module, Single Slot, Hardened

Physical Description

The following figure presents the elements of the dummy module:

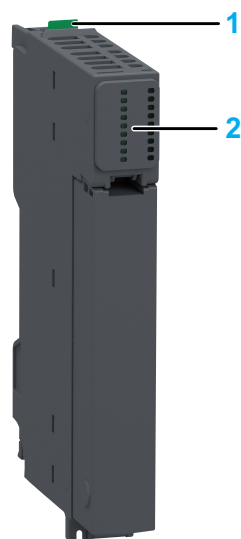

- 1: Release button for disengaging the module from the base
- 2: No LEDs are installed.

Dimension

The following figure presents the external dimensions of the assembled module:

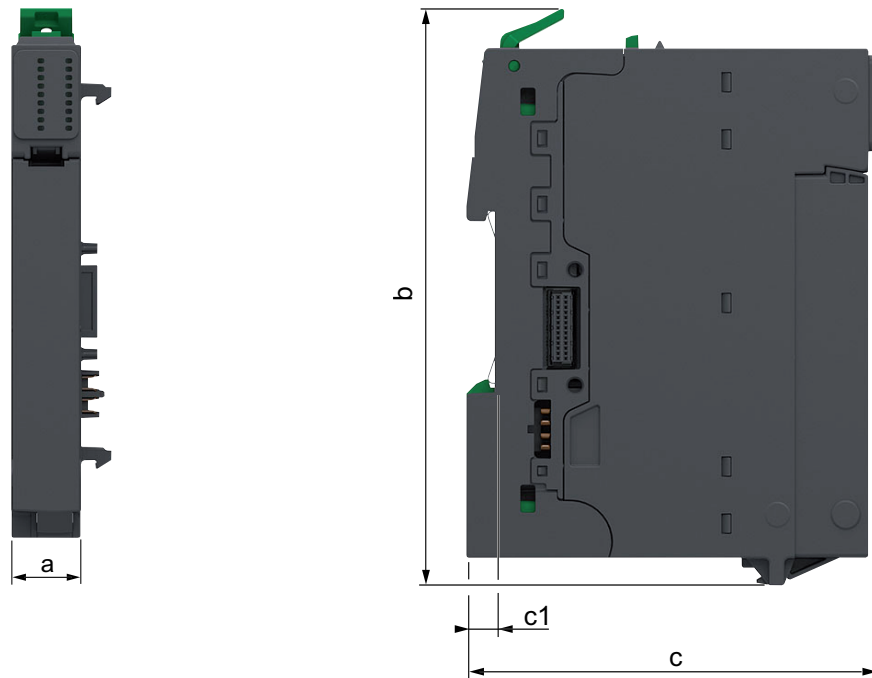

- a:** 15 mm (0.59 in)
- b:** 114.1 mm (4.49 in)
- c:** 80.7 mm (3.15 in)
- c1:** 5.6 mm (0.2 in)

Weight

- NTSDMY0100H: 32 g (1.13 oz)
- NTSDMY0100HK: 53 g (1.83 oz)

NTSDMY0200H Dummy Module, Double Slot, Hardened

Overview

The NTSDMY0200H is a non-functional module used as a placeholder for later system extension.

For more information on using a dummy module, refer to *The Layout of your Modicon Edge I/O NTS Island*, page 62.

Main Characteristics

The environmental characteristics of the NTSDMY0200H are described in the section *Operating Environment*, page 37.

⚠ WARNING

UNINTENDED EQUIPMENT OPERATION

Do not exceed any of the rated values specified in the environmental and electrical characteristics tables.

Failure to follow these instructions can result in death, serious injury, or equipment damage.

Purchasing Information

The following figure shows the elements of the Modicon Edge I/O NTS NTSDMY0200H dummy module:

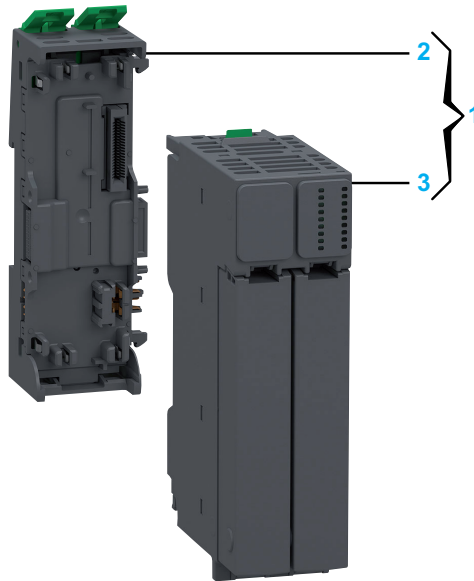

Number	Reference	Description
1	NTSDMY0200HK	Base + Module (kit) NOTE: The module and its corresponding base can be purchased as a kit.
2	NTSXBA0200H	Spare Base, 2 Slots, for Input/Output Common/Expert/Safety Module, Hardened
3	NTSDMY0200H	Dummy Module, Double Slot, Hardened

Physical Description

The following figure presents the elements of the dummy module:

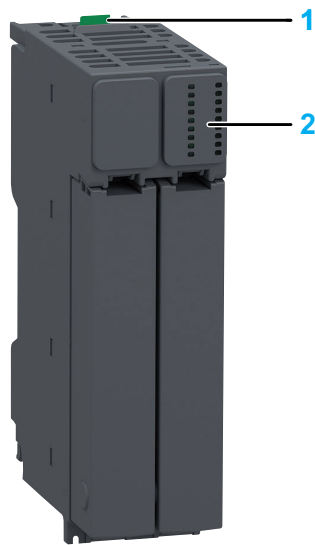

- 1: Release button for disengaging the module from the base
- 2: No LEDs are installed.

Dimension

The following figure presents the external dimensions of the assembled module:

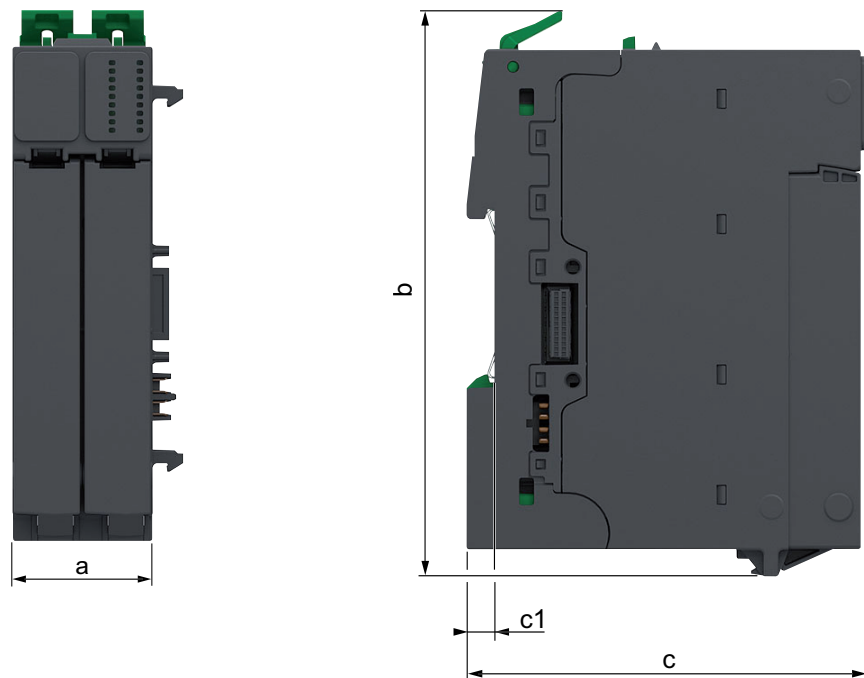

- a: 30 mm (1.18 in)
- b: 114.1 mm (4.49 in)
- c: 80.7 mm (3.15 in)
- c1: 5.6 mm (0.2 in)

Weight

- NTSDMY0200H: 50 g (1.76 oz)
- NTSDMY0200HK: 87 g (3.07 oz)

Cluster Termination

Overview

The Cluster Termination must be used on the rightmost position of the Modicon Edge I/O NTS cluster.

Purchasing Information

The following figure presents the elements of the Modicon Edge I/O NTS Cluster Termination:

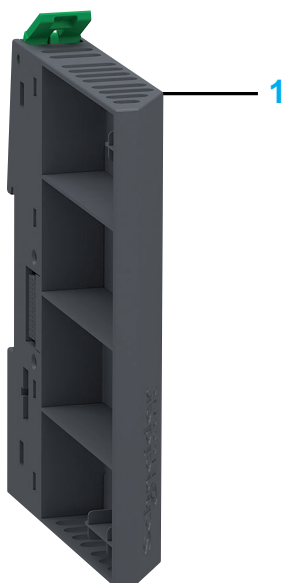

Number	Reference	Description
1	NTSXMP0000H	Spare Cluster Termination, Hardened.

Physical Description

The following figure presents the elements of the Cluster Termination:



Dimension

The following figure presents the external dimensions of the Cluster Termination:

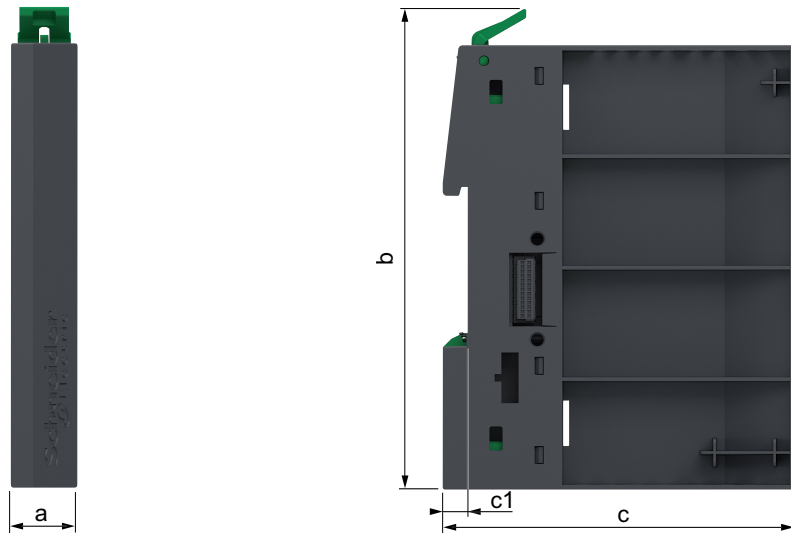

- a:** 15 mm (0.59 in)
- b:** 108.6 mm (4.27 in)
- c:** 79.1 mm (3.11 in)
- c1:** 5.6 mm (0.2 in)

Appendices

What's in This Part

Association Table	151
Current Consumption Tables for the Bus Power and 24 Vdc I/O Field Power Segment.....	159

Association Table

A Modicon Edge I/O NTS kit is composed of one I/O module and one compatible base. Each kit requires a compatible spring or screw terminal block that can be mounted on the I/O module.

To help determine the compatibility between a base and a module, a base and module color coding is applied on the front side of the base and on the rear side of the module. The color and the shape of the printing are the same for compatible bases and modules.

⚠ DANGER



INCOMPATIBLE COMPONENTS CAUSE ELECTRIC SHOCK OR ARC FLASH

- Always confirm the compatibility of the kit components before installation using the association table in this manual.
- Verify that correct terminal blocks are installed on the appropriate I/O modules.

Failure to follow these instructions will result in death or serious injury.



Network Interface Modules

The following table provides information on the compatibility of the spare bases and the network interface modules available in the Modicon Edge I/O NTS system:

Reference	Bases	
	NTSXB0201H	NTSXB0301H
Base and module coding		
NTSNEC1200	x	-
NTSNEC1200H	-	x
NTSNSC1200	x	-
x Compatible - Incompatible		

Discrete Input Modules

The following table provides information on the compatibility of the spare bases, discrete input modules, and terminal blocks available in the Modicon Edge I/O NTS system:

Reference	Bases		Terminal Blocks Spring				Terminal Blocks Screw			
	NTSXBAA0100H	NTSXBAA0200H	NTSXTB1220-H	NTSXTB1221-H	NTSXTB1820-H	NTSXTB1820-XH	NTSXTB1200-H	NTSXTB1201-H	NTSXTB1800-H	NTSXTB1800-XH
Base and module coding										
NTSDAI0215H	x	-	-	x	-	-	-	x	-	-
NTSDAI0403H	x	-	-	x	-	-	-	x	-	-
NTSDAI0404H	x	-	-	x	-	-	-	x	-	-
NTSDAI0804	x	-	-	x	-	-	-	x	-	-
NTSDDI0402	x	-	x	-	-	-	x	-	-	-
NTSDDI0402H	x	-	x	-	-	-	x	-	-	-
NTSDDI0602	x	-	-	-	x	-	-	-	x	-
NTSDDI0802X	x	-	-	-	-	x	-	-	-	x
NTSDDI1602	x	-	-	-	x	-	-	-	x	-
NTSDDI1602X	-	x	-	-	-	x	-	-	-	x
NTSDDI1602XH	-	x	-	-	-	x	-	-	-	x
NTSDDI1642	x	-	-	-	x	-	-	-	x	-
x Compatible - Incompatible										

Discrete Output Modules

The following table provides information on the compatibility of the spare bases, discrete output modules, and terminal blocks available in the Modicon Edge I/O NTS system:

Reference	Bases		Terminal Blocks Spring				Terminal Blocks Screw			
	NTSXB A0100H	NTSXB A0200H	NTSXTB1220-H	NTSXTB1221-H	NTSXTB1820-H	NTSXTB1820-XH	NTSXTB1200-H	NTSXTB1201-H	NTSXTB1800-H	NTSXTB1800-XH
Base and module coding	■	■								
NTSDDO0212H	x	-	x	-	-	-	x	-	-	-
NTSDDO0402	x	-	x	-	-	-	x	-	-	-
NTSDDO0402H	x	-	x	-	-	-	x	-	-	-
NTSDDO0602	x	-	-	-	x	-	-	-	x	-
NTSDDO0802	x	-	x	-	-	-	x	-	-	-
NTSDDO0802X	x	-	-	-	-	x	-	-	-	x
NTSDDO1602	x	-	-	-	x	-	-	-	x	-
NTSDDO1602X	-	x	-	-	-	x	-	-	-	x
NTSDDO1602XH	-	x	-	-	-	x	-	-	-	x
NTSDDO1602XA	-	x	-	-	-	x	-	-	-	x
NTSDDO1602XAH	-	x	-	-	-	x	-	-	-	x
NTSDAO0205	x	-	-	x	-	-	-	x	-	-
NTSDAO0415	-	x	-	x	-	-	-	x	-	-
NTSDAO0415H	-	x	-	x	-	-	-	x	-	-
NTSDRC0215	x	-	-	x	-	-	-	x	-	-
NTSDRC0415	-	x	-	x	-	-	-	x	-	-
NTSDRC0415H	-	x	-	x	-	-	-	x	-	-
NTSDRA0615	-	x	-	x	-	-	-	x	-	-
x Compatible										
- Incompatible										

Analog Input Modules

The following table provides information on the compatibility of the spare bases, analog input modules, and terminal blocks available in the Modicon Edge I/O NTS system:

Reference	Bases		Terminal Blocks Spring			Terminal Blocks Screw		
	NTSXBA0100H	NTSXBA0200H	NTSXTB1220•H	NTSXTB1820•H	NTSXTB1820•XH	NTSXTB1200•H	NTSXTB1800•H	NTSXTB1800•XH
Base and module coding	■	■						
NTSAMI0210	x	-	x	-	-	x	-	-
NTSAMI0210H	-	x	x	-	-	x	-	-
NTSAMI0400	x	-	x	-	-	x	-	-
NTSAMI0420	x	-	x	-	-	x	-	-
NTSAMI0800	x	-	-	x	-	-	x	-
NTSACI0802X	-	x	-	-	x	-	-	x
NTSACI0802XH	-	x	-	-	x	-	-	x
NTSAHI0412XH	-	x	-	-	x	-	-	x
NTSART0214	x	-	x	-	-	x	-	-
NTSART0214H	x	-	x	-	-	x	-	-
NTSART0404	x	-	x	-	-	x	-	-
NTSART0404XH	x	-	-	x	x	-	x	x
NTSART0603	x	-	-	x	-	-	x	-
x Compatible - Incompatible								

Analog Output Modules

The following table provide information on the compatibility of the spare bases, analog output modules, and terminal blocks available in the Modicon Edge I/O NTS system:

Reference	Bases		Terminal Blocks Spring			Terminal Blocks Screw		
	NTSXBA0100H	NTSXBA0200H	NTSXTB1220•H	NTSXTB1820•H	NTSXTB1820•XH	NTSXTB1200•H	NTSXTB1800•H	NTSXTB1800•XH
Base and module coding	■	■						
NTSAHO0212H	-	x	x	-	-	x	-	-
NTSAMO0210	x	-	x	-	-	x	-	-
NTSAMO0210H	x	-	x	-	-	x	-	-
NTSAMO0400	x	-	x	-	-	x	-	-
NTSAMO0400H	x	-	x	-	-	x	-	-
x Compatible - Incompatible								

Analog Mixed Input/Output Modules

The following table provide information on the compatibility of the spare bases, analog mixed input/output modules, and terminal blocks available in the Modicon Edge I/O NTS system:

Reference	Bases		Terminal Blocks Spring			Terminal Blocks Screw		
	NTSXBA0100H	NTSXBA0200H	NTSXTB1220•H	NTSXTB1820•H	NTSXTB1820•XH	NTSXTB1200•H	NTSXTB1800•H	NTSXTB1800•XH
Base and module coding	■	■						
NTSAMM0600	x	-	-	x	-	-	x	-
x Compatible - Incompatible								

Counting Input Modules

The following table provide information on the compatibility of the spare bases, counting input modules, and terminal blocks available in the Modicon Edge I/O NTS system:

Reference	Bases		Terminal Blocks Spring		Terminal Blocks Screw	
	NTSXBA0100H	NTSXBA0200H	NTSXTB1220•H	NTSXTB1820•H	NTSXTB1200•H	NTSXTB1800•H
Base and module coding	■	■				
NTSEHC0100	x	-	x	-	x	-
x Compatible - Incompatible						

Counting Mixed Input/Output Modules

The following table provide information on the compatibility of the spare bases, counting mixed input/output modules, and terminal blocks available in the Modicon Edge I/O NTS system:

Reference	Bases		Terminal Blocks Spring		Terminal Blocks Screw	
	NTSXBA0100H	NTSXBA0200H	NTSXTB1220•H	NTSXTB1820•H	NTSXTB1200•H	NTSXTB1800•H
Base and module coding	■	■				
NTSEHC0120H	-	x	x	-	x	-
NTSEHC0220	-	x	-	x	-	x
x Compatible - Incompatible						

Motion Expert Modules

The following table provide information on the compatibility of the spare bases, motion expert modules, and terminal blocks available in the Modicon Edge I/O NTS system:

Reference	Bases		Terminal Blocks Spring	Terminal Blocks Screw
	NTSXBA0100H	NTSXBA0200H	NTSXTB1820•H	NTSXTB1800•H
Base and module coding	■	■		
NTSEHE0221	-	x	x	x
NTSEME0101	x	-	x	x
NTSEME0102	x	-	x	x
NTSECS0121	-	x	x	x
NTSEME0110	x	-	x	x
NTSEDT0800	x	-	x	x
NTSEDT0810	x	-	x	x
NTSEDO0810	x	-	x	x
NTSEDM0822	x	-	x	x
NTSEMP0220	-	x	x	x
x Compatible - Incompatible				

Field Device Master Modules

The following table provide information on the compatibility of the spare bases, field device master modules, and terminal blocks available in the Modicon Edge I/O NTS system:

Reference	Base		Terminal Blocks Spring		Terminal Blocks Screw	
	NTSXBA0100H	NTSXBA0200H	NTSXTB1820•H	NTSXTB1220•H	NTSXTB1800•H	NTSXTB1200•H
Base and module coding	■	■				
NTSFMB0120	x	-	-	x	-	x
NTSFMB0120H	x	-	-	x	-	x
NTSFIO400	x	-	x	-	x	-
x Compatible - Incompatible						

Common Modules

The following table provide information on the compatibility of the spare bases, common modules, and terminal blocks available in the Modicon Edge I/O NTS system:

Reference	Bases		Terminal Blocks Spring	Terminal Blocks Screw
	NTSXBA0100H	NTSXBA0200H	NTSXTB1820+H	NTSXTB1800+H
Base and module coding	■	■		
NTSPCM0016H	x	-	x	x
NTSPCM0808H	x	-	x	x
NTSPCM1600H	x	-	x	x
x Compatible - Incompatible				

Power Supply Modules

The following table provide information on the compatibility of the spare bases, power supply modules, and terminal blocks available in the Modicon Edge I/O NTS system:

Reference	Bases		Terminal Blocks Spring	Terminal Blocks Screw
	NTSXBA0103H	NTSXBA0104H	NTSXTB02230H	NTSXTB02030H
Base and module coding	■	■		
NTSPFB1002H	x	-	x	x
NTSPFD1002H	-	x	x	x
x Compatible - Incompatible				

Current Consumption Tables for the Bus Power and 24 Vdc I/O Field Power Segment

Overview

The following tables provide the current consumption for the 24 Vdc bus and the 24 Vdc field power segment of the Modicon Edge I/O NTS modules with a 24 Vdc power supply at the maximum operating temperature.

Depending on the power supplied voltage, the current consumption can increase by 20%.

Discrete Input Modules

The following table provides the current consumption for the 24 Vdc bus and the 24 Vdc field power of the discrete input modules:

Reference	On the 24 Vdc bus	On the 24 Vdc field power		
	Current consumed by the module (mA)	Current consumed by the electronic module (mA)	Maximum current consumed by the loads (mA)	Maximum current consumed by the sensor/actuator/external device (mA)
NTSDDI0402	27.6	1.4	0.0	500.0
NTSDDI0402H	28.8	1.4	0.0	500.0
NTSDDI0602	31.2	10.1	0.0	500.0
NTSDDI0802X	32.4	10.1	0.0	200.0
NTSDDI1602	40.8	2.9	0.0	0.0
NTSDDI1602X	40.8	17.3	0.0	500.0
NTSDDI1602XH	40.8	17.3	0.0	500.0
NTSDDI1642	43.2	2.9	0.0	0.0
NTSDAI0215H	26.4	0.0	0.0	0.0
NTSDAI0403H	30.0	0.0	0.0	0.0
NTSDAI0404H	30.0	0.0	0.0	0.0
NTSDAI0804	32.4	0.0	0.0	0.0

Discrete Output Modules

The following table provides the current consumption for the 24 Vdc bus and the 24 Vdc field power of the discrete output modules:

Reference	On the 24 Vdc bus	On the 24 Vdc field power		
	Current consumed by the module (mA)	Current consumed by the electronic module (mA)	Maximum current consumed by the loads (mA)	Maximum current consumed by the sensor/actuator/external device (mA)
NTSDDO0212H	27.6	0.0	4,000.0	0.0
NTSDDO0402	30.0	10.1	2,000.0	0.0
NTSDDO0402H	30.0	10.1	2,000.0	0.0
NTSDDO0602	32.4	4.3	3,000.0	0.0
NTSDDO0802	33.6	0.0	0.0	0.0
NTSDDO0802X	33.6	4.3	4,000.0	0.0
NTSDDO1602	40.8	7.2	8,000.0	0.0
NTSDDO1602X	40.8	8.6	4,000.0	0.0
NTSDDO1602XH	40.8	8.6	4,000.0	0.0
NTSDDO1602XA	42.0	0.0	0.0	0.0
NTSDDO1602XAH	42.0	0.0	0.0	0.0
NTSDAO0205	30.0	0.0	0.0	0.0
NTSDAO0415	37.2	0.0	0.0	0.0
NTSDAO0415H	37.2	0.0	0.0	0.0
NTSDRC0215	27.6	1.4	40.0	0.0
NTSDRC0415	30.0	1.4	20.0	0.0
NTSDRC0415H	30.0	1.4	20.0	0.0
NTSDRA0615	31.2	1.4	40.0	0.0

Analog Input Modules

The following table provides the current consumption for the 24 Vdc bus and the 24 Vdc field power of the analog input modules:

Reference	On the 24 Vdc bus	On the 24 Vdc field power		
	Current consumed by the module (mA)	Current consumed by the electronic module (mA)	Maximum current consumed by the loads (mA)	Maximum current consumed by the sensor/actuator/external device (mA)
NTSAMI0210	36.0	46.1	0.0	50.0
NTSAMI0210H	36.0	46.1	0.0	50.0
NTSAMI0400	31.7	23.0	0.0	0.0
NTSAMI0420	31.7	33.1	0.0	0.0
NTSAMI0800	34.6	33.1	0.0	0.0
NTSACI0802X	36.0	28.8	0.0	180.0
NTSACI0802XH	36.0	28.8	0.0	180.0
NTSAHI0412XH	36.0	63.4	0.0	100.0
NTSART0214	36.0	20.2	0.0	0.0
NTSART0214H	36.0	20.2	0.0	0.0
NTSART0404	36.0	36.0	0.0	0.0
NTSART0404XH	36.0	36.0	0.0	0.0
NTSART0603	36.0	30.2	0.0	0.0

Analog Output Modules

The following table provides the current consumption for the 24 Vdc bus and the 24 Vdc field power of the analog output modules:

Reference	On the 24 Vdc bus	On the 24 Vdc field power		
	Current consumed by the module (mA)	Current consumed by the electronic module (mA)	Maximum current consumed by the loads (mA)	Maximum current consumed by the sensor/actuator/external device (mA)
NTSAHO0212H	37.4	40.9	41.6	0.0
NTSAMO0210	34.6	19.6	46.4	0.0
NTSAMO0210H	34.6	19.6	46.4	0.0
NTSAMO0400	34.6	28.8	84.0	0.0
NTSAMO0400H	34.6	28.8	84.0	0.0

Analog Input/Output Modules

The following table provides the current consumption for the 24 Vdc bus and the 24 Vdc field power of the analog input/output modules:

Reference	On the 24 Vdc bus	On the 24 Vdc field power		
	Current consumed by the module (mA)	Current consumed by the electronic module (mA)	Maximum current consumed by the loads (mA)	Maximum current consumed by the sensor/actuator/external device (mA)
NTSAMM0600	37.4	34.0	46.4	0.0

Counting Input Modules

The following table provides the current consumption for the 24 Vdc bus and the 24 Vdc field power of the counting input modules:

Reference	On the 24 Vdc bus	On the 24 Vdc field power		
	Current consumed by the module (mA)	Current consumed by the electronic module (mA)	Maximum current consumed by the loads (mA)	Maximum current consumed by the sensor/actuator/external device (mA)
NTSEHC0100	31.7	0.0	0.0	0.0

Counting Input/Output Modules

The following table provides the current consumption for the 24 Vdc bus and the 24 Vdc field power of the counting input/output modules:

Reference	On the 24 Vdc bus	On the 24 Vdc field power		
	Current consumed by the module (mA)	Current consumed by the electronic module (mA)	Maximum current consumed by the loads (mA)	Maximum current consumed by the sensor/actuator/external device (mA)
NTSEHC0120H	34.6	14.4	2,000.0	0.0
NTSEHC0220	40.3	25.9	2,000.0	0.0

Field Device Master Modules

The following table provides the current consumption for the 24 Vdc bus and the 24 Vdc field power of the field device master modules:

Reference	On the 24 Vdc bus	On the 24 Vdc field power		
	Current consumed by the module (mA)	Current consumed by the electronic module (mA)	Maximum current consumed by the loads (mA)	Maximum current consumed by the sensor/actuator/external device (mA)
NTSFMB0120	31.2	28.8	0.0	0.0
NTSFMB0120H	31.2	28.8	0.0	0.0
NTSFIO0400	42.0	9.6	800.0	900.0

Motion Expert Modules

The following table provides the current consumption for the 24 Vdc bus and the 24 Vdc field power of the motion expert modules:

Reference	On the 24 Vdc bus	On the 24 Vdc field power		
	Current consumed by the module (mA)	Current consumed by the electronic module (mA)	Maximum current consumed by the loads (mA)	Maximum current consumed by the sensor/actuator/external device (mA)
NTSEHE0221	43.9	34.8	2,760.0	0.0
NTSEME0101	29.5	4.8	150.0	0.0
NTSEME0102	30.7	4.8	105.6	0.0
NTSEME0110	29.5	14.4	42.0	0.0
NTSECS0121	38.9	27.3	2,150.0	0.0
NTSEDT0800	30.8	0.0	0.0	0.0
NTSEDT0810	33.6	11.5	2,000.0	0.0
NTSEDO0810	33.6	11.5	2,000.0	0.0
NTSEDM0822	32.9	5.8	1,000.0	0.0
NTSEMP0220	41.7	72.0	100.0	0.0

Network Interface Modules

The following table provides the current consumption for the 24 Vdc bus and the 24 Vdc field power of the network interface module modules:

Reference	On the 24 Vdc bus	On the 24 Vdc field power		
	Current consumed by the module (mA)	Current consumed by the electronic module (mA)	Maximum current consumed by the loads (mA)	Maximum current consumed by the sensor/actuator/external device (mA)
NTSNEC1200	144.0	-	-	-
NTSNEC1200H	144.0	-	-	-
NTSNSC1200	144.0	-	-	-

Power Supply Modules

The following table provides the current consumption for the 24 Vdc bus and the 24 Vdc field power of the power supply modules:

Reference	On the 24 Vdc bus	On the 24 Vdc field power		
	Current consumed by the module (mA)	Current consumed by the electronic module (mA)	Maximum current consumed by the loads (mA)	Maximum current consumed by the sensor/actuator/external device (mA)
NTSPFB1002H	-3,500.0	3.4	-10,500	0.0
NTSPFD1002H	3.6	4.2	-10,500	0.0

Common Distribution Modules

The following table provides the current consumption for the 24 Vdc bus and the 24 Vdc field power of the common distribution modules:

Reference	On the 24 Vdc bus	On the 24 Vdc field power		
	Current consumed by the module (mA)	Current consumed by the electronic module (mA)	Maximum current consumed by the loads (mA)	Maximum current consumed by the sensor/actuator/external device (mA)
NTSPCM0016H	3.6	0.0	0.0	0.0
NTSPCM0808H	3.6	3.6	10,500	0.0
NTSPCM1600H	3.6	3.6	10,500	0.0

Dummy Modules

The following table provides the current consumption for the 24 Vdc bus and the 24 Vdc field power of the dummy modules:

Reference	On the 24 Vdc bus	On the 24 Vdc field power		
	Current consumed by the module (mA)	Current consumed by the electronic module (mA)	Maximum current consumed by the loads (mA)	Maximum current consumed by the sensor/actuator/external device (mA)
NTSDMY0100H	0.0	0.0	0.0	0.0
NTSDMY0200H	0.0	0.0	0.0	0.0

Index

A		P	
Accessories	34	Power Distribution	46
NSYTRAABV35	35	Power Supply Modules	
NTSXMP1000	35	NTSPFB1002H	96
NTSXMP2000	35	NTSPFD1002H	101
B		T	
Bases		Terminal Blocks	
NTSXBA0100H	129	NTSXTB02030H	140
NTSXBA0103H	130	NTSXTB02230H	140
NTSXBA0104H	131	NTSXTB12000H	135
NTSXBA0200H	129	NTSXTB12001H	135
NTSXBA0201H	130	NTSXTB12010H	138
NTSXBA0301H	130	NTSXTB12011H	138
C		NTSXTB12200H	135
Certifications and standards	40	NTSXTB12201H	135
Clear Cover		NTSXTB12210H	138
NTSXEM0000H	134	NTSXTB12211H	138
NTSXEM0000XH	134	NTSXTB18000H	135
Cluster Termination		NTSXTB18000XH	135
NTSXMP0000H	148	NTSXTB18001H	135
Common Distribution Modules		NTSXTB18001XH	135
NTSPCM0016H	107	NTSXTB18200H	135
NTSPCM0808H	113	NTSXTB18200XH	135
NTSPCM1600H	120	NTSXTB18201H	135
Current consumption tables		NTSXTB18201XH	135
24 Vdc bus	159	W	
24 Vdc field power	159	Wiring best practices	49
D		Wiring rules	49
Dummy Modules		E	
NTSDMY100H	142	Electrical requirements	49
NTSDMY200H	144	Environmental characteristics	37
E		Equipment removal	81
Electrical requirements	49	complete configuration	81
Environmental characteristics	37	partial configuration	82
Equipment removal	81	H	
complete configuration	81	Hot swapping	91
partial configuration	82	I	
H		Installation	
Hot swapping	91	DIN rail installation	64
I		M	
Installation		Minimum clearances	41
DIN rail installation	64	Mounting position	41
M			
Minimum clearances	41		
Mounting position	41		

Schneider Electric
35 rue Joseph Monier
92500 Rueil Malmaison
France

www.se.com

As standards, specifications, and design change from time to time, please ask for confirmation of the information given in this publication.

© 2026 Schneider Electric. All rights reserved.

EIO0000004786.05