

Lexium 28S and BCH2 Servo Drive System

User Guide

Original instructions

EIO0000004027.02
09/2025



Sercos
the automation bus

Legal Information

The information provided in this document contains general descriptions, technical characteristics and/or recommendations related to products/solutions.

This document is not intended as a substitute for a detailed study or operational and site-specific development or schematic plan. It is not to be used for determining suitability or reliability of the products/solutions for specific user applications. It is the duty of any such user to perform or have any professional expert of its choice (integrator, specifier or the like) perform the appropriate and comprehensive risk analysis, evaluation and testing of the products/solutions with respect to the relevant specific application or use thereof.

The Schneider Electric brand and any trademarks of Schneider Electric SE and its subsidiaries referred to in this document are the property of Schneider Electric SE or its subsidiaries. All other brands may be trademarks of their respective owner.

This document and its content are protected under applicable copyright laws and provided for informative use only. No part of this document may be reproduced or transmitted in any form or by any means (electronic, mechanical, photocopying, recording, or otherwise), for any purpose, without the prior written permission of Schneider Electric.

Schneider Electric does not grant any right or license for commercial use of the document or its content, except for a non-exclusive and personal license to consult it on an "as is" basis.

Schneider Electric reserves the right to make changes or updates with respect to or in the content of this document or the format thereof, at any time without notice.

To the extent permitted by applicable law, no responsibility or liability is assumed by Schneider Electric and its subsidiaries for any errors or omissions in the informational content of this document, as well as any non-intended use or misuse of the content thereof.

© 2025 Schneider Electric. All rights reserved.

Table of Contents

Safety Information	9
QUALIFICATION OF PERSONNEL	9
INTENDED USE	10
About the Book	11
Servo Drive System Planning	17
General Overview	18
Servo Drive Device Overview	18
Drive / Motor References	19
Document Navigator	23
Document Navigator	23
Servo Drive System Technical Data	24
Certifications	25
Conditions for UL 508C	25
Drive	26
General Overview	26
Servo Drive Description	26
Servo Drive Nameplate	27
Servo Drive Type Code	28
Drive Technical Data	28
Environmental Conditions	28
Dimensions	30
Weights	31
Electrical Data	32
Single-Phase Connection	33
Three-Phase Connection	34
Inputs / Outputs Characteristics	36
Motor	39
General Overview	39
Components and Interfaces	39
Servo Motor Nameplate	40
Servo Motor Type Code	41
Motor Technical Data	43
Environmental Conditions	43
Tightening Torque and Property Class of Screws	44
Overload Characteristics Curves	44
Encoder Technical Data	45
BCH2MB Motor	46
BCH2MB Dimensions	46
BCH2MB Characteristics Table	46
BCH2MB Curves	48
BCH2LD Motor	49
BCH2LD Dimensions	49
BCH2LD Characteristics Table	49
BCH2LD Curves	50
BCH2·F Motor	51
BCH2·F Dimensions	51
BCH2·F Characteristics Table	51
BCH2·F Curves	53

BCH2LH Motor	54
BCH2LH Dimensions	54
BCH2LH Characteristics Table	54
BCH2LH Curves	55
BCH2·M Motor.....	56
BCH2·M Dimensions	56
BCH2·M Characteristics Table.....	56
BCH2·M Curves	58
BCH2·R Motor	60
BCH2·R Dimensions	60
BCH2·R Characteristics Table	61
BCH2·R Curves	63
Accessories and Spare Parts.....	65
Commissioning Tools	65
Connectors and Adapters	65
External Mains Filters	66
DC Bus Accessories	66
Application Nameplate	66
Ethernet Shielded Twisted-pair Cables	66
SERCOS III Cables with Connectors	67
Motor Cables.....	67
Encoder Cables and Accessories.....	68
Signal Cables	68
Signal Cable for Safety Function STO.....	68
External Braking Resistors and Holding Brake Controller	68
Circuit Breakers	69
Motor Protection Switches and Power Contactors	69
Engineering.....	70
Engineering	71
Electromagnetic Compatibility (EMC)	71
Electromagnetic Compatibility (EMC).....	71
External Mains Filters	73
Cables	74
Cables.....	74
Residual Current Device.....	75
Residual Current Device	75
Common DC Bus.....	76
Common DC Bus	76
Safety Function STO (“Safe Torque Off”)	76
Process Minimizing Risks Associated with the Machine.....	76
Functional Safety	78
Definitions	80
Function	81
Requirements for Using the Safety Function.....	82
Application Examples STO	85
Rating the Braking Resistor	88
Rating the Braking Resistor.....	88
Internal Braking Resistor.....	88
External Braking Resistors.....	89
Monitoring Functions.....	90
Monitoring Functions	90

Configurable Inputs and Outputs	91
Configurable Inputs and Outputs	91
Wiring	91
General Wiring	91
Installation	92
Before Mounting	94
Inspecting the Product	94
Scope of Supply	94
Drive Installation	95
Mechanical Installation Drive	95
Electrical Installation Drive	98
Connection Grounding Screw	99
Connection I/O Interface (CN1)	100
Connecting the Motor Encoder (CN2)	107
Connection PC (CN3)	109
Connection Fieldbus (CN4)	110
Connection Logic Supply and Power Stage Supply (CN5)	112
Connection DC Bus (CN6)	114
Connection Braking Resistor (CN7)	115
Connecting the Motor Phases (CN8)	117
Holding Brake Connection	120
Connection STO (CN9)	121
Motor Installation	124
Mechanical Installation Motor	124
Connections and Pin Assignments	127
Connection of Motor and Encoder	129
Holding Brake Connection	131
Verifying Installation	133
Verifying Installation	133
Commissioning	134
Overview	135
General	135
Commissioning Tools	137
Integrated HMI	138
Overview	138
Integrated HMI Structure	139
7-Segment Display	139
Status Information Via the HMI	141
Commissioning Procedure	143
Commissioning Software	143
Setting the Device Address, Baud Rate and Connection Settings	143
Verifying the Direction of Movement	146
Verifying the Safety Function STO	147
Tuning the Control Loops	149
Tuning the Control Loops	149
Easy Tuning	149
Comfort Tuning	150
Manual Tuning	156
Parameters	169

Parameters	170
Representation of the Parameters	170
P0 - Status Parameters	171
P1 - Basic Parameters.....	177
P2 - Extended Parameters.....	186
P3 - Communication Parameters.....	193
P4 - Diagnostics Parameters	196
P5 - Motion Settings	199
P8 - Control Loops	205
P9 - DTM Data.....	215
Operation	222
Operation.....	223
Access Channels	223
Operating States.....	224
Setting the Digital Signal Inputs.....	225
Setting the Digital Signal Outputs	226
Functions for Target Value Processing	228
Setting a Signal Output Via Parameter.....	229
Forcing the Digital Signal Inputs and Signal Outputs	229
Position Capture via Signal Input.....	231
Operating Modes.....	236
Setting the Operating Mode	236
Setting the Operating Mode	236
Indication of the Operating State via Fieldbus	236
Changing the Operating State via Fieldbus.....	237
Object units	238
Jog Operation.....	240
Jog Operation	240
Cyclic Synchronous Operating Modes	241
Overview	241
Operating Mode Homing	243
Operating Mode Homing.....	243
Diagnostics and Troubleshooting	248
Diagnostics and Troubleshooting	249
SERCOS III Status.....	249
Diagnostics Via the Integrated HMI	250
Diagnostics Via the Signal Outputs.....	251
Diagnostics Via the Commissioning Software.....	251
Status Information on Detected Errors	251
Connection for Fieldbus Mode	253
Alert Codes and Error Codes	253
Service, Maintenance and Disposal.....	261
Service, Maintenance, and Disposal	262
General.....	262
Service Address	263
Maintenance of the Drive.....	263
Replacement of Drive.....	264
Maintenance of the Motor	264
Lexium 26/28 Multi-Turn Encoder.....	266
Introduction	266

Operation	268
Multi-Turn Methods (LXM28S).....	272
Changing the Motor	276
Shipping, Storage, Disposal.....	276
Fieldbus	278
SERCOS III IDN's.....	279
SERCOS III IDN's Overview	279
List of SERCOS III Standard IDN's Parameters Supported	279
List of Mappable Parameters to RT Data	291
P0...P11 Object Group	293
P0 Object Group	293
P1 Object Group	295
P2 Object Group	300
P3 Object Group	302
P4 Object Group	304
P5 Object Group	305
P8 Object Group	307
P9 Object Group	312
P11 Object Group.....	315
Device-Specific Object Group	317
Device-Specific Object Group	317
SERCOS III Hardware Setup.....	324
SERCOS III Connector Description (CN4)	324
Cable Routing Practices	324
Glossary	327
Index	332

Safety Information

Important Information

Read these instructions carefully, and look at the equipment to become familiar with the device before trying to install, operate, service, or maintain it. The following special messages may appear throughout this documentation or on the equipment to warn of potential hazards or to call attention to information that clarifies or simplifies a procedure.





The addition of this symbol to a "Danger" or "Warning" safety label indicates that an electrical hazard exists which will result in personal injury if the instructions are not followed.



This is the safety alert symbol. It is used to alert you to potential personal injury hazards. Obey all safety messages that follow this symbol to avoid possible injury or death.

 DANGER
DANGER indicates a hazardous situation which, if not avoided, will result in death or serious injury.

 WARNING
WARNING indicates a hazardous situation which, if not avoided, could result in death or serious injury.

 CAUTION
CAUTION indicates a hazardous situation which, if not avoided, could result in minor or moderate injury.

NOTICE
NOTICE is used to address practices not related to physical injury.

Please Note

Electrical equipment should be installed, operated, serviced, and maintained only by qualified personnel. No responsibility is assumed by Schneider Electric for any consequences arising out of the use of this material.

A qualified person is one who has skills and knowledge related to the construction and operation of electrical equipment and its installation, and has received safety training to recognize and avoid the hazards involved.

QUALIFICATION OF PERSONNEL

Only appropriately trained persons who are familiar with and understand the contents of this manual and all other pertinent product documentation are authorized to work on and with this product. These persons must have sufficient technical training, knowledge and experience and be able to foresee and detect potential hazards that may be caused by using the product, by modifying the settings and by the mechanical, electrical and electronic equipment of the entire system in which the product is used.

All persons working on and with the product must be fully familiar with all applicable standards, directives, and accident prevention regulations when performing such work.

INTENDED USE

The products described or affected by this document are, along with software, accessories and options, servo drive systems for servo motors and intended for industrial use according to the instructions, directions, examples and safety information contained in the present document and other supporting documentation.

The products may only be used in compliance with all applicable safety regulations and directives, the specified requirements and the technical data.

Prior to using the products, you must perform a risk assessment in view of the planned application. Based on the results, the appropriate safety-related measures must be implemented.

Since the products are used as components in an entire system, you must ensure the safety of persons by means of the design of this entire system.

Operate the products only with the specified cables and accessories. Use only genuine accessories and spare parts.

Any use other than the use explicitly permitted is prohibited and can result in hazards.

About the Book

Document Scope

This document describes the functions of the Servo Drive LXM28S and the BCH2 motor.

Validity Note

This document has been updated with the firmware release of the Lexium 28S V2.78.

The characteristics of the products described in this document are intended to match the characteristics that are available on www.se.com. As part of our corporate strategy for constant improvement, we may revise the content over time to enhance clarity and accuracy. If you see a difference between the characteristics in this document and the characteristics on www.se.com, consider www.se.com to contain the latest information.

Related Documents

Use your tablet or your PC to quickly access detailed and comprehensive information on all our products on www.se.com.

The internet site provides the information you need for products and solutions:

- The whole catalog for detailed characteristics and selection guides,
- The CAD files to help design your installation,
- All software and firmware to maintain your installation up to date,
- And finally all the User Guides related to your drive, listed below:

Title of documentation	Reference number
Lexium 28S and BCH2 Servo Drive System - User Guide (This document)	EIO0000004027 (English)
Lexium 28S DTM Commissioning software - User Guide	EIO0000002466 (English)
LXM28 - Common DC bus - Application note	0198441114085-EN (English) 0198441114084-DE (German) 0198441114086-FR (French) 0198441114087-IT (Italian) 0198441114088-ES (Spanish) 0198441114089-ZH (Chinese)
HBC Holding Brake Controller -Product Manual	0198441113316 (English)
Multi-loader - User Manual	BBV48778 (English) BBV48777 (French)

To find documents online, visit the Schneider Electric download center (www.se.com/ww/en/download/).

Product Related Information

The use and application of the information contained herein require expertise in the design and programming of automated control systems.

Only you, the user, machine builder or integrator, can be aware of all the conditions and factors present during installation and setup, operation, repair and maintenance of the machine or process.

You must also consider any applicable standards and/or regulations with respect to grounding of all equipment. Verify compliance with any safety information, different electrical requirements, and normative standards that apply to your machine or process in the use of this equipment.

Many components of the equipment, including the printed circuit board, operate with mains voltage, or present transformed high currents, and/or high voltages.

The motor itself generates voltage when the motor shaft is rotated.

DANGER

ELECTRIC SHOCK, EXPLOSION OR ARC FLASH

- Disconnect all power from all equipment including connected devices prior to removing any covers or doors, or installing or removing any accessories, hardware, cables, or wires.
- Place a "Do Not Turn On" or equivalent hazard label on all power switches and lock them in the non-energized position.
- Wait 15 minutes to allow the DC bus capacitors to properly discharge.
- Measure the DC bus voltage between the DC bus terminals (PA/+ and PC/-) to verify that DC bus capacitors are properly discharged (voltage less than 42.4 Vdc).
- Do not assume that the DC bus discharged properly when the DC bus LED is off.
- Block the motor shaft to prevent rotation prior to performing any type of work on the drive system.
- Do not create a short-circuit across the DC bus terminals or the DC bus capacitors.
- Replace and secure all covers, accessories, hardware, cables, and wires and confirm that a proper ground connection exists before applying power to the unit.
- Use only the specified voltage when operating this equipment and any associated products.

Failure to follow these instructions will result in death or serious injury.

This equipment has been designed to operate outside of any hazardous location. Only install this equipment in zones known to be free of a hazardous atmosphere.

DANGER

POTENTIAL FOR EXPLOSION

Install and use this equipment in non-hazardous locations only.

Failure to follow these instructions will result in death or serious injury.

If the power stage is disabled unintentionally, for example as a result of power outage, errors or functions, the motor is no longer decelerated in a controlled way. Overload, errors or incorrect use may cause the holding brake to no longer operate properly and may result in premature wear.

▲ WARNING**UNINTENDED EQUIPMENT OPERATION**

- Verify that movements without braking effect cannot cause injuries or equipment damage.
- Verify the function of the holding brake at regular intervals.
- Do not use the holding brake as a service brake.
- Do not use the holding brake for safety-related purposes.

Failure to follow these instructions can result in death, serious injury, or equipment damage.

Drive systems may perform unanticipated movements because of incorrect wiring, incorrect settings, incorrect data or other errors.

▲ WARNING**UNINTENDED MOVEMENT OR MACHINE OPERATION**

- Carefully install the wiring in accordance with the EMC requirements.
- Do not operate the product with undetermined settings and data.
- Perform comprehensive commissioning tests that include verification of configuration settings and data that determine position and movement.

Failure to follow these instructions can result in death, serious injury, or equipment damage.

▲ WARNING**LOSS OF CONTROL**

- The designer of any control scheme must consider the potential failure modes of control paths and, for certain critical control functions, provide a means to achieve a safe state during and after a path failure. Examples of critical control functions are emergency stop and overtravel stop, power outage and restart.
- Separate or redundant control paths must be provided for critical control functions.
- System control paths may include communication links. Consideration must be given to the implications of unanticipated transmission delays or failures of the link.
- Observe all accident prevention regulations and local safety guidelines.¹
- Each implementation of this equipment must be individually and thoroughly tested for proper operation before being placed into service.

Failure to follow these instructions can result in death, serious injury, or equipment damage.

¹ For additional information, refer to NEMA ICS 1.1 (latest edition), "Safety Guidelines for the Application, Installation, and Maintenance of Solid State Control" and to NEMA ICS 7.1 (latest edition), "Safety Standards for Construction and Guide for Selection, Installation and Operation of Adjustable-Speed Drive Systems" or their equivalent governing your particular location.

DC Bus Voltage Measurement

The DC bus voltage can exceed 400 Vdc. The DC bus LED is not an indicator of the absence of DC bus voltage.

 **DANGER**

ELECTRIC SHOCK, EXPLOSION OR ARC FLASH

- Disconnect the voltage supply to all connections.
- Wait 15 minutes to allow the DC bus capacitors to properly discharge.
- Use a suitably-rated voltage sensing device for measuring (range greater than 400 Vdc).
- Measure the DC bus voltage between the DC bus terminals (PA/+ and PC/-) to verify that DC bus capacitors are properly discharged (voltage less than 42.4 Vdc).
- Contact your local Schneider Electric representative if the DC bus capacitors do not discharge to less than 42.4 Vdc within a period of 15 minutes.
- Do not operate the product if the DC bus capacitors do not discharge properly.
- Do not attempt any repairs involving opening the drive case.
- Do not attempt to replace cables, connectors or the drive itself if the DC bus capacitors are not discharged to a voltage level less than 42 Vdc.
- Do not assume that the DC bus discharged properly when the DC bus LED is off.

Failure to follow these instructions will result in death or serious injury.



Terminology Derived from Standards

The technical terms, terminology, symbols and the corresponding descriptions in this manual, or that appear in or on the products themselves, are generally derived from the terms or definitions of international standards.

In the area of functional safety systems, drives and general automation, this may include, but is not limited to, terms such as *safety*, *safety function*, *safe state*, *fault*, *fault reset*, *malfunction*, *failure*, *error*, *error message*, *dangerous*, etc.

Among others, these standards include:

Standard	Description
IEC 61131-2:2017	Programmable controllers, part 2: Equipment requirements and tests.
ISO 13849-1:2015 ISO 13849-2:2023	Safety of machinery - Safety related parts of control systems - Part 1: General principles for design Part 2: Validation
EN 61496-1:2013	Safety of machinery: Electro-sensitive protective equipment. Part 1: General requirements and tests.
ISO 12100:2010	Safety of machinery - General principles for design - Risk assessment and risk reduction
BS EN 60204-1:2018	Safety of machinery - Electrical equipment of machines - Part 1: General requirements
ISO 14119:2013	Safety of machinery - Interlocking devices associated with guards - Principles for design and selection
ISO 13850:2015	Safety of machinery - Emergency stop - Principles for design
IEC 62061:2021	Safety of machinery - Functional safety of safety-related electrical, electronic, and programmable electronic control systems

Standard	Description
EN 61508:2010 Parts 1-7	Functional safety of electrical/electronic/programmable electronic safety-related systems.
EN 61800-5-2:2017	Adjustable speed electrical power drive systems - Part 5-2: Safety requirements - Functional
IEC 61800-5-1:2022	Adjustable speed electrical power drive systems - Part 5-1: Safety requirements - Electrical, thermal and energy
IEC 61784-3:2016	Industrial communication networks - Profiles - Part 3: Functional safety fieldbuses - General rules and profile definitions.
(EU) 2023/1230	Machinery Regulation
2014/30/EU	Electromagnetic Compatibility Directive
2014/35/EU	Low Voltage Directive
IEC 61800-3: 2017	Adjustable speed electrical power drive systems - Part 3: EMC requirements and specific test methods
EN IEC 61000-6-2: 2019	Electromagnetic compatibility (EMC) - Part 6-2: Generic standards - Immunity standard for industrial environments
EN 61000-6-7: 2015	Electromagnetic compatibility (EMC) - Part 6-7: Generic standards - Immunity requirements for equipment intended to perform functions in a safety-related system (functional safety) in industrial locations
IEC 61326: 2017	Immunity requirements for safety-related systems and for equipment intended to perform safety-related functions (functional safety) - General industrial applications
BS EN 61326-3-1: 2017	Electrical equipment for measurement, control and laboratory use - EMC requirements - Part 3-1: Immunity requirements for safety-related systems and for equipment intended to perform safety-related functions (functional safety) - General industrial applications
  ISO 7010-M002: 2011-05	Refer to instruction manual/booklet (Refer to instruction, Installation, user's and/or maintenance manuals)

In addition, terms used in the present document may tangentially be used as they are derived from other standards such as:

Standard	Description
IEC 60034 series	Rotating electrical machines
IEC 61800 series	Adjustable speed electrical power drive systems
IEC 61158 series	Digital data communications for measurement and control – Fieldbus for use in industrial control systems

Finally, the term *zone of operation* may be used in conjunction with the description of specific hazards, and is defined as it is for a *hazard zone* or *danger zone* in the *Machinery Regulation (EU) 2023/1230* and *ISO 12100:2010*.

NOTE: The aforementioned standards may or may not apply to the specific products cited in the present documentation. For more information concerning the individual standards applicable to the products described herein, see the characteristics tables for those product references.

Servo Drive System Planning

What's in This Part

General Overview	18
Document Navigator.....	23

General Overview

What's in This Chapter

Servo Drive Device Overview	18
Drive / Motor References	19

Servo Drive Device Overview

Presentation

The servo drive system includes:

- the drive, page 26 and the motor, page 39:



- the accessories and spare parts, page 65:



Item	Description
1	Commissioning tools, page 65
2	Connectors and adapters, page 65
3	External mains filters, page 66
4	DC Bus accessories, page 66
5	Application nameplate, page 66
6	Fieldbus accessories, page 66
7	Motor cables, page 67
8	Encoder cables, page 68
9	Signal cables, page 68
10	Signal cables for safety function STO, page 68
11	External braking resistors, page 68
12	Circuit breakers, page 69
13	Motor protection switches and power contractors, page 69

Drive / Motor References

Introduction

The present user guide provides information about the following Drives and Motors reference tables.

The Lexium 28S range is defined by AC-servo drives Lexium 28S for combination with AC-servo motors BCH2.

- The combinations of servo motors with servo drives are based on the power class: both servo motor and servo drive must have the same power class.
- The bundle of a servo drive with its related servo motor is designed to cover a nominal power from:
 - 0.05 kW up to 4.5 kW (0.067 up to 6.03 hp) with 200...240 V mains supply voltage.

Compatibility between Drive and Motor is defined in the Drive / Motor combinations table, page 21.

Lexium 28S Drive References List

Drive references	Nominal power	Supply mains
LXM28SUA5M3X	50 W	single phase or 3-phase, 230 Vac
LXM28SU01M3X	100 W	single phase or 3-phase, 230 Vac
LXM28SU02M3X	200 W	single phase or 3-phase, 230 Vac
LXM28SU04M3X	400 W	single phase or 3-phase, 230 Vac
LXM28SU07M3X	750 W	single phase or 3-phase, 230 Vac
LXM28SU10M3X	1000 W	single phase or 3-phase, 230 Vac
LXM28SU15M3X	1500 W	single phase or 3-phase, 230 Vac
LXM28SU20M3X	2000 W	3-phase, 230 Vac
LXM28SU30M3X	3000 W	3-phase, 230 Vac
LXM28SU45M3X	4500 W	3-phase, 230 Vac

For further information, refer to the servo drive general overview, page 26.

BCH2 Motor References List

Motor references	Nominal power
BCH2MBA53...5C	50 W
BCH2MB013...5C	100 W
BCH2LD023...5C	200 W
BCH2MM031...6C	300 W
BCH2LD043...5C	400 W
BCH2LF043...5C	400 W
BCH2MM052...6C	500 W
BCH2MM061...6C	600 W
BCH2HF073...5C	750 W
BCH2LF073...5C	750 W
BCH2MM081...6C	850 W
BCH2MM091...6C	900 W
BCH2MM102...6C	1000 W
BCH2HM102...6C	1000 W
BCH2LH103...6C	1000 W
BCH2MM152...6C	1500 W
BCH2MM202...6C	2000 W
BCH2MR202...6C	2000 W
BCH2HR202...6C	2000 W
BCH2LH203...6C	2000 W
BCH2MR301...6C	3000 W
BCH2MR302...6C	3000 W
BCH2MR352...6C	3500 W
BCH2MR451...6C	4500 W

For further information, refer to Servo Motor Type Code, page 41.

Drive / Motor Combinations

The permissible Drive / Motor Combinations are detailed in the following table:

Drive	Motor	Nomi- nal power	Nomi- nal speed of rota- tion	Nomi- nal torque	Peak torque	Rotor inertia with- out hold- ing brake	Mo- ment of inertia
		W	rpm	Nm	Nm	kg. cm ²	-
Devices 220 Vac that can be connected via a single phase or three phases							
LXM28SUA5M3X	BCH2MBA53...5-C	50	3000	0.16	0.48	0.054	Medium
	Hardware version RS 01 or RS 02					0.044	
	BCH2MBA53...5-C						
	Hardware version RS 03						
LXM28SU01M3X	BCH2MB013...5C	100	3000	0.32	0.96	0.075	Medium
	Hardware version RS 01 or RS 02					0.065	
	BCH2MB013...5C						
	Hardware version RS 03						
LXM28SU02M3X	BCH2LD023...5C	200	3000	0.64	1.92	0.16	Low
LXM28SU04M3X	BCH2MM031...6-C	300	1000	2.86	8.59	6.63	Medium
	BCH2LD043...5C	400	3000	1.27	3.81	0.27	Low
	BCH2LF043...5C	400	3000	1.27	3.81	0.67	Low
LXM28SU07M3X	BCH2MM052...6-C	500	2000	2.39	7.16	6.63	Medium
	BCH2MM061...6-C	600	1000	5.73	17.19	6.63	Medium
	BCH2LF073...5C	750	3000	2.39	7.16	1.19	Low
	BCH2HF073...5C	750	3000	2.39	7.16	1.54	High
LXM28SU10M3X	BCH2MM081...6-C	850	1500	5.39	13.8	13.5	Medium
	BCH2MM091...6-C	900	1000	8.59	25.77	9.7	Medium
	BCH2LH103...6C	1000	3000	3.18	9.54	2.4	Low
	BCH2MM102...6-C	1000	2000	4.77	14.3	6.63	Medium
	BCH2HM102...6C	1000	2000	4.77	14.3	8.41	High
LXM28SU15M3X	BCH2MM152...6-C	1500	2000	7.16	21.48	9.7	Medium
Devices 220 Vac that can be connected via three phases							
LXM28SU20M3X	BCH2LH203...6C	2000	3000	6.37	19.11	4.28	Low
	BCH2MM202...6-C	2000	2000	9.55	28.65	13.5	Medium
	BCH2MR202...6C	2000	2000	9.55	28.65	26.5	Medium
	BCH2HR202...6C	2000	2000	9.55	28.65	34.68	High
LXM28SU30M3X	BCH2MR301...6C	3000	1500	19.1	57.29	53.56	Medium

Drive	Motor	Nomi- nal power	Nomi- nal speed of rota- tion	Nomi- nal torque	Peak torque	Rotor inertia with- out hold- ing brake	Mo- ment of inertia
		W	rpm	Nm	Nm	kg. cm ²	-
	BCH2MR302...6C	3000	2000	14.32	42.97	53.56	Medi- um
LXM28SU45M3X	BCH2MR352...6C	3500	2000	16.7	50.3	53.56	Medi- um
	BCH2MR451...6C	4500	1500	28.65	71.62	73.32	Medi- um

Document Navigator

What's in This Chapter

Document Navigator.....	23
-------------------------	----

Document Navigator

Document Content

This user guide contains following data:

- Technical data, page 24
 - Conditions for UL 508C, page 25
 - Drive, page 26
 - Motor, page 39
 - Accessories and spare parts, page 65
- Engineering, page 70
- Installation, page 92
 - Before mounting, page 94
 - Drive installation, page 95
 - Motor installation, page 124
 - Verifying installation, page 133
- Commissioning, page 134
 - Overview, page 135
 - Integrated HMI, page 138
 - Commissioning procedure, page 143
 - Tuning the control loop, page 149
- Parameters, page 169
- Operation, page 222
 - Operation, page 223
 - Operating modes, page 236
- Diagnostics and troubleshooting, page 248
- Service, maintenance and disposal, page 261
- Fieldbus, page 278
 - SERCOS III IDN's, page 279
 - SERCOS III Hardware Setup, page 324

Servo Drive System Technical Data

What's in This Part

Certifications	25
Drive	26
Motor	39
Accessories and Spare Parts	65

Certifications

What's in This Chapter

Conditions for UL 508C.....25

Download links

Item	Link
UL certification status	UL_InfoBY01
EU Declaration of conformity	NHA3487100
TÜV certificate	TUEV_0120554010014

Conditions for UL 508C

Introduction

The UL certification status can be downloaded on the Schneider Electric website.

If the product is used to comply with UL 508C, the following conditions must also be met.

Wiring

Use copper conductors only, at least 75 °C (167 °F) rating.

Fuses

Use fuses as per UL 248 or circuit breaker as per UL 489.

LXM28S	UA5, U01, U02, U04, U07, U10, U15	U20, U30, U45
Maximum fuse rating of fuse to be connected upstream	25 A	32 A
Class if fuses are used	J	J
Class if circuit breakers are used	D	D

Overvoltage Category

Use only in overvoltage category III or where the maximum available Rated Impulse Withstand Voltage Peak is equal or less than 4000 Volts, or equivalent as defined in UL 840 and its equivalent defined in IEC 60664-1.

Drive

What's in This Chapter

General Overview	26
Drive Technical Data.....	28

General Overview

Servo Drive Description

Presentation

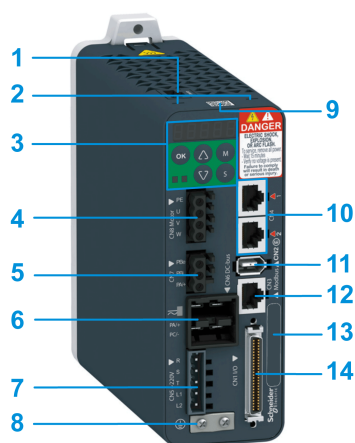

Item	Description	Connector
1	Connector for safety function STO	CN9, page 121
2	Slot for application name plate (VW3M2501)	-
3	HMI: 7-segment display, 5 buttons, and 2 status LED	-
4	Terminal for motor connection	CN8, page 117
5	Terminal for braking resistor connection	CN7, page 115
6	DC-bus connector with status LED	CN6, page 114
7	Terminal for connecting the power supply	CN5, page 112
8	Screw terminal for protective ground (protective earth)	-
9	QR code for access to technical data	-
10	2 x RJ45 connectors for integrated fieldbus connection	CN4, page 110
11	Connector for the encoder of the motor	CN2, page 107
12	RJ45 connector for Modbus serial link	CN3, page 109
13	Device Reference	-
14	Input/output connector	CN1, page 100

Integrated Fieldbus

The Lexium 28S Servo Drive has an integrated dual port SERCOS III adapter that can be used in a SERCOS III industrial fieldbus.

Parameters Access

Servo drive parameters, page 170 may be accessed using:

- The integrated HMI
- The Device Type Manager (DTM)
- Directly using the fieldbus address of the device to read and write to parameters using the object dictionary

Object Dictionary

The SERCOS III IDN's s may be accessed through the fieldbus, using their address.

Three groups of IDN's are available.

- Standard IDN's, page 279
- Manufacturer-specific IDN's, page 293
- Mappable IDN's to RT data, page 291

Servo Drive Nameplate

Presentation

The nameplate contains the following data:

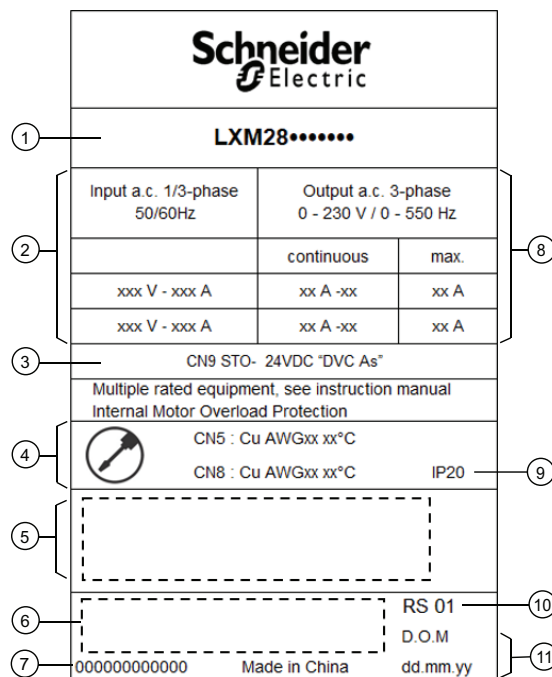

Item	Description
1	Drive reference
2	Logic supply
3	STO connector safety voltage class
4	Cable specifications
5	Certifications
6	Barcode
7	Serial number
8	Output power

Item	Description
9	Degree of protection
10	Hardware version
11	Date of manufacture

Servo Drive Type Code

Servo Drive Type Code

Item	1	2	3	4	5
Type code (example)	LXM	28	S	U07	M3X

Item	Meaning
1	Product designation LXM = Lexium
2	Product type 28 = AC servo drive for one axis
3	Interfaces S = SERCOS III, I/O interface, commissioning via Modbus RTU
4	Continuous power UA5 = 0.05 kW U01 = 0.1 kW U02 = 0.2 kW U04 = 0.4 kW U07 = 0.75 kW U10 = 1 kW U15 = 1.5 kW U20 = 2 kW U30 = 3 kW U45 = 4.5 kW
5	Power stage supply [Vac] M3X = single phase or 3-phase, 200/230 Vac

Drive Technical Data

Environmental Conditions

Ambient Conditions During Operation

The maximum permissible ambient temperature during operation depends on the mounting distances between the devices and on the required power. Observe the instructions in the chapter Installation, page 95.

Description	Unit	Value
Surrounding temperature without current derating (no icing, non-condensing)	°C (°F)	0...40 (32...104)
Surrounding temperature with current derating of 1% per 1 °C (1.8 °F)	°C (°F)	40...55 (104...131)

The following relative humidity is permissible during operation:

Description	Unit	Value
Relative humidity (non-condensing)	%	<95

Description	Unit	Value
Installation altitude above mean sea level without current derating	m (ft)	<2000 (<6561)

Ambient Conditions During Transportation and Storage

The environment during transportation and storage must be dry and free from dust.

Description	Unit	Value
Temperature	°C (°F)	-25...65 (-4...149)

The following relative humidity is permissible during transportation and storage:

Description	Unit	Value
Relative humidity (non-condensing)	%	<95

Installation Site and Connection

For operation, the device must be mounted in a closed control cabinet with a degree of protection of at least IP 54. The device may only be operated with a permanently installed connection.

⚠️⚠️ DANGER	
ELECTRIC SHOCK, EXPLOSION, OR ARC FLASH	
Install the drive in a control cabinet or housing with a minimum IP 54 rating.	
Failure to follow these instructions will result in death or serious injury.	

Pollution Degree and Degree of Protection

Description	Value
Pollution degree	2
Degree of protection	IP20

Degree of Protection When the Safety Function Is Used

You must ensure that conductive substances cannot get into the product (pollution degree 2). Conductive substances may cause the safety function to become inoperative.

STO input CN9 is 24 VDC "DVC As" - Not for use in wet locations.

⚠ WARNING

INOPERABLE SAFETY FUNCTION

Ensure that conductive substances (water, contaminated or impregnated oils, metal shavings, etc.) cannot get into the drive.

Failure to follow these instructions can result in death, serious injury, or equipment damage.

Vibration and Shock During Operation

Description	Value
Class as per IEC 60721-3-3	3M4 3 mm from 9...200 Hz
Maximum shock	98.1 m/s ² (10 g) Type I

Vibration and Shock During Transportation and Storage

Description	Value
Class as per IEC 60721-3-2	2M2 3.5 mm (2...9 Hz) 9.81 m/s ² (1 g) from 9...200 Hz 14.715 m/s ² (1.5 g) from 200...500 Hz 34.335 m/s ² (3.5 g) from 2...9 Hz
Maximum shock	294.3 m/s ² (30 g) Type II

Dimensions

Lexium 28S Dimensions

LXM28SUA5, LXM28SU01, LXM28SU02, LXM28SU04, LXM28SU07,
LXM28SU10, LXM28SU15, LXM28SU20

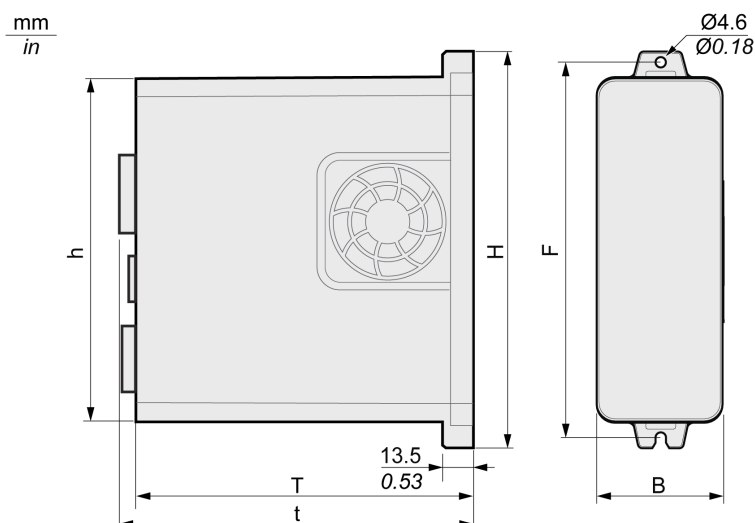

LXM28S	Unit	UA5M3X, U01M3X, U02M3X, U04M3X, U07M3X	U10M3X, U15M3X	U20M3X
B	mm (in)	55 (2.17)	55 (2.17)	62 (2.44)
H	mm (in)	173.2 (6.82)	173.5 (6.83)	194.5 (7.66)
h	mm (in)	150 (5.91)	150 (5.91)	170 (6.69)
F	mm (in)	164 (6.46)	164 (6.46)	185 (7.28)
T	mm (in)	146 (5.75)	170 (6.69)	184 (7.24)
t	mm (in)	152.7 (6.01)	176.3 (6.94)	197 (7.76)

LXM28SU30, LXM28SU45

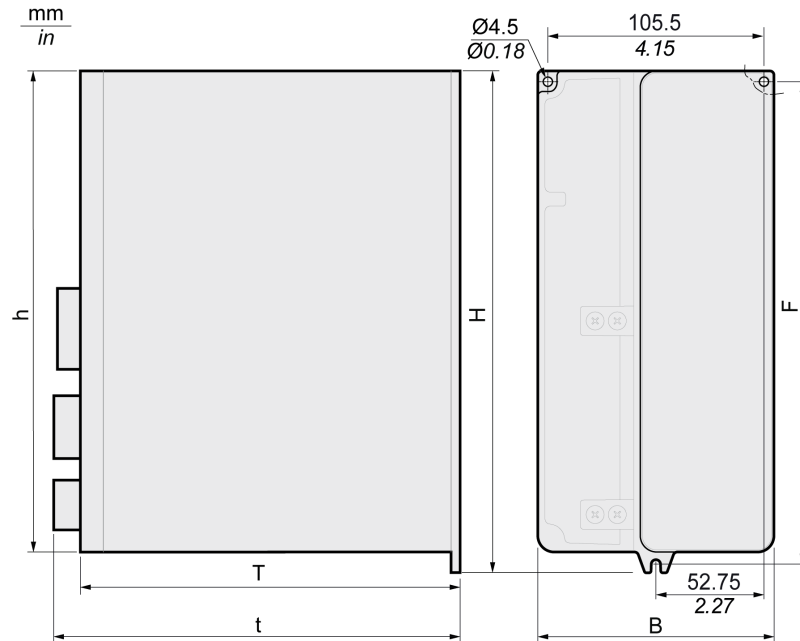

LXM28S	Unit	U30M3X, U45M3X
B	mm (in)	116 (4.57)
H	mm (in)	245 (9.65)
h	mm (in)	234 (9.21)
F	mm (in)	235 (9.25)
T	mm (in)	186 (7.32)
t	mm (in)	199 (7.83)

Weights

Lexium 28S Weights

Reference	Unit	Weight
LXM28SUA5M3X	kg	1.3
LXM28SU01M3X	kg	1.3
LXM28SU02M3X	kg	1.3
LXM28SU04M3X	kg	1.3
LXM28SU07M3X	kg	1.3

Reference	Unit	Weight
LXM28SU10M3X	kg	1.5
LXM28SU15M3X	kg	1.5
LXM28SU20M3X	kg	2
LXM28SU30M3X	kg	4
LXM28SU45M3X	kg	4

Electrical Data

Introduction

The products are intended for industrial use and may only be operated with a permanently installed connection.

220 Vac Mains Voltage: Range and Tolerance

LXM28S•••M3X

Description	Unit	Value
220 Vac single-phase/three-phase (LXM28S•••M3X)	Vac	200 -15 % ... 230 +10 %
Frequency	Hz	50 -5 % ... 60 +5 %
Transient overvoltages	–	Overtoltage category III ⁽¹⁾
Rated voltage to ground	Vac	220 V (System voltage < 300 V)
(1)	Depends on installation altitude, see Environmental Conditions, page 28	

Type of Grounding

Description	Value
TT grounding system, TN grounding system	Approved
IT mains	Not approved
Mains with grounded line conductor	Not approved

Leakage Current

Description	Unit	Value
Leakage current (as per IEC 60990, figure 3)	mA	<30 ⁽¹⁾
(1)	Measured on mains with grounded neutral point and without external mains filter. Take into account that a 30 mA RCD can already trigger at 15 mA. In addition, there is a high-frequency leakage current which is not considered in the measurement. The response to this depends on the type of residual current device.	

Monitoring of the Continuous Output Power

The continuous output power is monitored by the device. If the continuous output power is exceeded, the device reduces the output current.

PWM Frequency Power Stage

PWM frequency power stage The PWM frequency of the power stage is set to a fixed value.

LXM28S	UA5, U01, U02, U04, U07, U10, U15	U20, U30, U45
PWM frequency power stage	16 kHz	8 kHz

Type of Cooling

LXM28S	UA5, U01, U02	U04, U07, U10, U15, U20, U30, U45
Type of cooling	Convection	Fan

Permissible Drive / Motor Combinations

The BCH2 motors can be connected to the Lexium 28S drive range.

Compatibility between Drive and Motor is defined in the Drive / Motor combinations table, page 21.

Single-Phase Connection

Electrical Data for LXM28S...M3X Drive Connected Via a Single-Phase 220 Vac

LXM28S...M3X	Unit	UA5	U01	U02	U04	U07	U10	U15	
Nominal voltage	V	230 (single-phase)							
Inrush current limitation	A	8							
Maximum fuse to be connected upstream ⁽¹⁾	A	25							
Short-circuit current rating (SCCR)	kA	5							
Continuous output current	A _{rms}	0.64	0.9	1.5	2.6	4.5	7	7	
Peak output current	A _{rms}	2	2.7	4.5	7.8	13.5	21	21	
Nominal power ⁽²⁾	W	50	100	200	400	750	1000	1500	
Input current ⁽²⁾⁽³⁾	A _{rms}	0.8	1.2	2.4	3.8	6	8.5	10	
THD (total harmonic distortion) ⁽²⁾⁽⁴⁾	%	262.8	239.2	226.8	211.6	181.8	176.3	166.6	
Power dissipation ⁽⁵⁾	W	8	10	14	22	38	36	41	
Maximum inrush current ⁽⁶⁾	A	175					235		

LXM28S...M3X	Unit	UA5	U01	U02	U04	U07	U10	U15	
Time for maximum inrush current	ms	0.5					0.6		
(1)	As per IEC 60269; Circuit breakers with C characteristic; See Conditions for UL 508C, page 25 for UL; Lower ratings are permissible; The fuse must be rated in such a way that the fuse does not trip at the specified input current.								
(2)	At a mains impedance corresponding to the short-circuit current rating (SCCR)								
(3)	At nominal power and nominal voltage								
(4)	With reference to the input current								
(5)	Condition: internal braking resistor not active; value at nominal current, nominal voltage, and nominal power; value approximately proportional with output current								
(6)	Extreme case, off/on pulse before the inrush current limitation responds, see next line for maximum time								

DC bus data for drives connected via a single-phase 220 Vac

LXM28S...M3X	Unit	UA5	U01	U02	U04	U07	U10	U15
Nominal voltage (single-phase)	Vac	230						
Nominal voltage DC bus	Vdc	322						
Undervoltage limit	Vdc	160						
Overvoltage limit	Vdc	420						
Maximum continuous power via DC bus	W	50	100	200	400	750	1000	1500
Maximum continuous power via DC bus	A	0.2	0.3	0.6	1.2	2.3	3.1	4.6

Three-Phase Connection

Electrical Data for LXM28S...M3X Drive Connected Via Three-Phase 220 Vac

LXM28S...M3X	Unit	UA5	U01	U02	U04	U07	U10
Nominal voltage	V	230 (3-phase)					
Inrush current limitation	A	8					
Maximum fuse to be connected upstream ⁽¹⁾	A	25					
Short-circuit current rating (SCCR)	kA	5					
Continuous output current	A _{rms}	0.64	0.9	1.5	2.6	4.5	7
Peak output current	A _{rms}	2	2.7	4.5	7.8	13.5	21
Nominal power ⁽²⁾	W	50	100	200	400	750	1000
Input current ⁽²⁾⁽³⁾	A _{rms}	0.42	0.74	1.25	2.2	3.9	5
THD (total harmonic distortion) ⁽²⁾⁽⁴⁾	%	227.8	212.7	200.7	183.7	160.8	155.5
Power dissipation ⁽⁵⁾	W	8	10	14	22	38	36
Maximum inrush current ⁽⁶⁾	A	175					235

LXM28S...M3X		Unit	UA5	U01	U02	U04	U07	U10	
Time for maximum inrush current		ms	0.5					0.6	
(1)	As per IEC 60269; Circuit breakers with C characteristic; See Conditions for UL 508C, page 25 for UL; Lower ratings are permissible; The fuse must be rated in such a way that the fuse does not trip at the specified input current.								
(2)	At a mains impedance corresponding to the short-circuit current rating (SCCR)								
(3)	At nominal power and nominal voltage								
(4)	With reference to the input current								
(5)	Condition: internal braking resistor not active; value at nominal current, nominal voltage, and nominal power; value approximately proportional with output current								
(6)	Extreme case, off/on pulse before the inrush current limitation responds, see next line for maximum time								

LXM28S...M3X		Unit	U15	U20	U30	U45
Nominal voltage		V	230 (3-phase)			
Inrush current limitation		A	8	19.2	17	
Maximum fuse to be connected upstream ⁽¹⁾		A	25	32		
Short-circuit current rating (SCCR)		kA	5		22	
Continuous output current		A _{rms}	7	12	19.8	22.8
Peak output current		A _{rms}	21	36	60	61
Nominal power ⁽²⁾		W	1500	2000	3000	4500
Input current ⁽²⁾⁽³⁾		A _{rms}	5.9	8.7	12.9	18
THD (total harmonic distortion) ⁽²⁾⁽⁴⁾		%	144.8	137.1	155.8	147.1
Power dissipation ⁽⁵⁾		W	41		97	
Maximum inrush current ⁽⁶⁾		A	235	295	300	
Time for maximum inrush current		ms	0.6	1.0		
(1)	As per IEC 60269; Circuit breakers with C characteristic; See Conditions for UL 508C, page 25 for UL; Lower ratings are permissible; The fuse must be rated in such a way that the fuse does not trip at the specified input current.					
(2)	At a mains impedance corresponding to the short-circuit current rating (SCCR)					
(3)	At nominal power and nominal voltage					
(4)	With reference to the input current					
(5)	Condition: internal braking resistor not active; value at nominal current, nominal voltage, and nominal power; value approximately proportional with output current					
(6)	Extreme case, off/on pulse before the inrush current limitation responds, see next line for maximum time					

DC bus data for drives connected via three-phase 220 Vac

LXM28S...M3X		Unit	UA5	U01	U02	U04	U07	U10
Nominal voltage (three phases)		Vac	230					
Nominal voltage DC bus		Vdc	322					
Undervoltage limit		Vdc	160					
Overvoltage limit		Vdc	420					
Maximum continuous power via DC bus		W	50	100	200	400	750	1000
Maximum continuous power via DC bus		A	0.2	0.3	0.6	1.2	2.3	3.1

LXM28S...M3X	Unit	U15	U20	U30	U45
Nominal voltage (three phases)	Vac	230			
Nominal voltage DC bus	Vdc	322			
Undervoltage limit	Vdc	160			
Overvoltage limit	Vdc	420			
Maximum continuous power via DC bus	W	1500	2000	3000	4500
Maximum continuous power via DC bus	A	4.6	6.2	9.2	13.8

Inputs / Outputs Characteristics

Logic Type

The outputs are short-circuit protected. The inputs and outputs are galvanically isolated.

The digital inputs and outputs of this product can be wired for positive or negative logic.

Logic type	Active state
Positive logic	Output supplies current (source output) Current flows to the input (sink input)
Negative logic	Output draws current (sink output) Current flows from the input (source input)

Digital Input Signals 24 V

When wired as positive logic, the levels of the opto-isolated inputs DI1...DI5 and DI8 comply with IEC 61131-2, type 1. The electrical characteristics are also valid when wired as negative logic.

Description	Unit	Value
"0" signal voltage	Vdc	≤5
"1" signal voltage	Vdc	≥11
Input current (typical)	mA	6
Debounce time ⁽¹⁾	ms	0...20
(1)	Adjustable via parameter P2-09 in increments of 1 ms.	

Digital Output Signals 24 V

The levels of the digital 24 V output signals DO· comply with IEC 61131-2.

Description	Unit	Value
Switching voltage	Vdc	24
Maximum switching current	mA	100
Voltage drop at 100 mA load	Vdc	< 3

Touch Probe Input Signals 24 V

When wired as positive logic, the levels of the opto-isolated inputs DI6 and DI7 comply with IEC 61131-2, type 1. The electrical characteristics are also valid when wired as negative logic.

Description	Unit	Value
"0" signal voltage	Vdc	≤5
"1" signal voltage	Vdc	≥11
Input current (typical)	mA	7
Debounce time ⁽¹⁾	μs	0...16384
Jitter Capture	μs	1

(1)	Adjustable via parameter P2-24 in increments of 1 μs.
-----	---

Safety Function STO

The signal inputs **STO_0V** and **STO_24V** (CN9) are protected against reverse polarity.

Description	Unit	Value
Nominal voltage	Vdc	24
PELV power supply unit	–	Required
"0" signal voltage ⁽¹⁾	Vdc	< 5
"1" signal voltage ⁽¹⁾	Vdc	15...30
Input current (typical)	mA	190
LXM28SUA5M3X, U01M3X, U02M3X, U04M3X, U07M3X		190
LXM28SU10M3X, U15M3X		190
LXM28SU20		240
LXM28SU30, U45		240
Maximum peak current	A	18
Maximum frequency for OSSD (Output Signal Switching Device) test pulses	Hz	475
Debounce time	ms	< 1
Response time of safety function STO	ms	< 40

(1)	Voltage level according to IEC 61131-2 type 2 with the exception of the operation with 15 Vdc instead of 11 Vdc. The condition between 5 Vdc and 15 Vdc is undefined and not permissible.
-----	---

For further information, refer to data for maintenance plan and the calculation for the safety function, page 79.

24 Vdc Power Supply (Pin 17):

24 Vdc power supply (pin 17):

Description	Unit	Value
Output voltage	Vdc	24
Maximum output current	mA	200

Ethernet Signals:

The Ethernet signals comply with the Ethernet standard.

ESIM Output Signals

The ESIM output signals comply with the RS422 interface specification.

Description	Unit	Value		
Logic level	–	As per RS422 ⁽¹⁾		
Output frequency per signal	kHz	800		
Maximum output frequency (quadruple evaluation)	kHz	3200		
<table border="1" style="width: 100%;"> <tr> <td style="width: 15%;">(1)</td> <td>Due to the input current of the optocoupler in the input circuit, a parallel connection of a driver output to several devices is not permitted.</td> </tr> </table>			(1)	Due to the input current of the optocoupler in the input circuit, a parallel connection of a driver output to several devices is not permitted.
(1)	Due to the input current of the optocoupler in the input circuit, a parallel connection of a driver output to several devices is not permitted.			

Motor

What's in This Chapter

General Overview	39
Motor Technical Data	43
BCH2MB Motor	46
BCH2LD Motor	49
BCH2-F Motor	51
BCH2LH Motor	54
BCH2-M Motor	56
BCH2-R Motor	60

General Overview

Components and Interfaces

Presentation

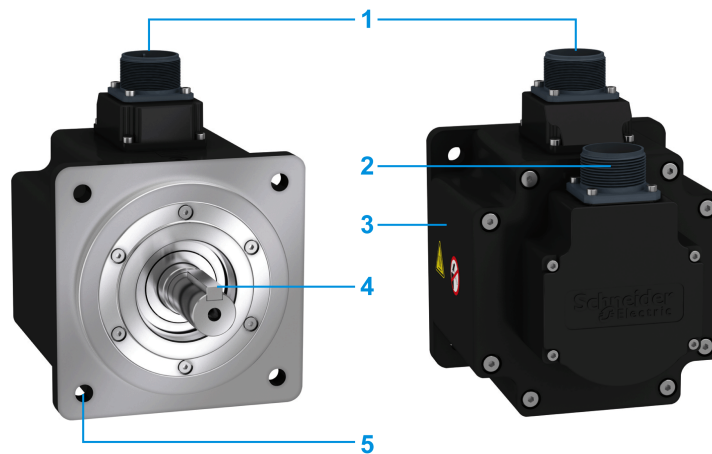

BCH2 servo motors, with a 3-phase stator and rotor with rare earth-based permanent magnets, consist of:

Item	Description
1	Connector of the motor cable, page 67
2	Connector of the encoder cable, page 68
3	Housing
4	Smooth or keyed shaft end, depending on the motor reference
5	4-point axial mounting flange

Servo Motor Nameplate

BCH2-B

The nameplate contains the following data:

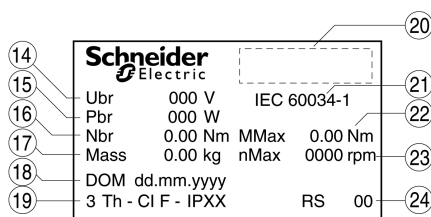
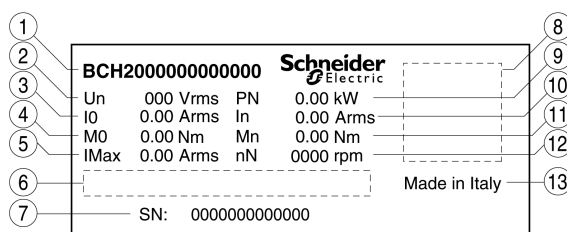

Item	Description	Item	Description
1	Motor reference, page 41	13	Country of manufacture
2	Nominal voltage	14	Nominal voltage of the holding brake (optional)
3	Continuous stall current	15	Nominal power of the holding brake (optional)
4	Continuous stall torque	16	Nominal torque of the holding brake (optional)
5	Maximum current	17	Mass
6	Barcode	18	Date of manufacture DOM
7	Serial number	19	Number of motor phases, temperature class, degree of protection
8	QR code	20	Certifications
9	Nominal power	21	Applied standard
10	Nominal current	22	Peak torque
11	Nominal torque	23	Maximum permissible speed of rotation
12	Nominal speed of rotation	24	Hardware version

BCH2-D, BCH2-F, BCH2-H, BCH2-M, and BCH2-R

The nameplate contains the following data:

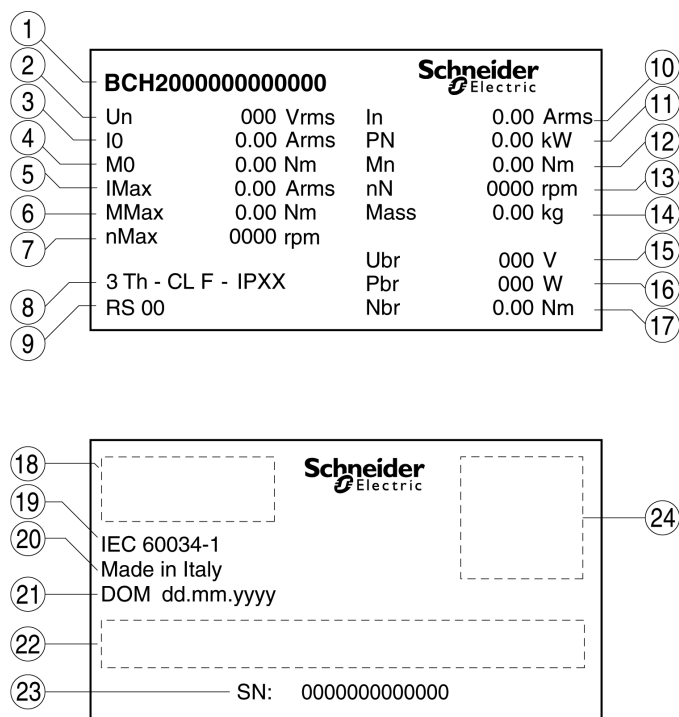

Item	Description	Item	Description
1	Motor reference, page 41	13	Nominal speed of rotation
2	Nominal voltage	14	Mass
3	Continuous stall current	15	Nominal voltage of the holding brake (optional)
4	Continuous stall torque	16	Nominal power of the holding brake (optional)
5	Maximum current	17	Nominal torque of the holding brake (optional)
6	Peak torque	18	Certifications
7	Maximum permissible speed of rotation	19	Applied standard
8	Number of motor phases, temperature class, degree of protection	20	Country of manufacture
9	Hardware version	21	Date of manufacture DOM
10	Nominal current	22	Barcode
11	Nominal power	23	Serial number
12	Nominal torque	24	QR code

Servo Motor Type Code

Servo Motor Type Code

Item	1	2	3	4	5	6	7	8	9	10
Type code (example)	BC-H2	M	B	01	3	3	C	A	5	C

Item	Meaning	
1	Product family BCH2 = Brushless servo motors - second generation	
2	Moment of inertia L = Low M = Medium H = High	
3	Size (housing) B = 40 mm flange D = 60 mm flange F = 80 mm flange H = 100 mm flange M = 130 mm flange R = 180 mm flange	
4	Nominal power A5 = 50 W 01 = 100 W 02 = 200 W 03 = 300 W 04 = 400 W 05 = 500 W 06 = 600 W 07 = 750 W 08 = 850 W 09 = 900 W	10 = 1.0 kW 13 = 1.3 kW 15 = 1.5 kW 20 = 2.0 kW 30 = 3.0 kW 35 = 3.5 kW 45 = 4.5 kW
5	Winding 1 = Optimized in terms of torque (1000 rpm/1500 rpm) 2 = Optimized in terms of torque and speed of rotation (2000 rpm) 3 = Optimized in terms of speed of rotation (3000 rpm)	
6	Shaft and degree of protection⁽¹⁾ 0 = Smooth shaft; degree of protection: shaft IP 54, housing IP 65 ⁽²⁾ 1 = Parallel key; degree of protection: shaft IP 54, housing IP 65 ⁽²⁾ 2 = Smooth shaft; degree of protection: shaft and housing IP 65 3 = Parallel key; degree of protection: shaft and housing IP 65	
7	Encoder system C = High-resolution encoder single-turn M = High-resolution encoder multi-turn	
8	Holding brake A = Without holding brake F = With holding brake	
9	Connection version 5 = Flying leads (for BCH2-B, BCH2-D, BCH2-F) 6 = MIL connector (for BCH2-H, BCH2-M, BCH2-R)	

Item	Meaning
10	Mechanical interface - mounting C = Asian style
(1) In the case of mounting position IM V3 (drive shaft vertical, shaft end up), the motor has degree of protection IP 50. (2) Only available with single-turn encoder, up to 4.5 kW.	

Motor Technical Data

Environmental Conditions

Ambient Conditions During Operation

The maximum permissible ambient temperature during operation depends on the mounting distances between the devices and on the required power. Observe the instructions in the chapter Installation, page 124.

Description	Unit	Value
Ambient temperature ⁽¹⁾ for motors without holding brake (no icing, non-condensing).	°C (°F)	-20...40 (-4...104)
Ambient temperature for motors with holding brake (no icing, non-condensing).	°C (°F)	0...40 (32...104)
Ambient temperature with current derating of 1% per °C (per 1.8 °F)	°C (°F)	40...60 (104...140)
Relative humidity (non-condensing)	%	5...85
Class as per IEC 60721-3-3	-	3K3, 3Z12, 3Z2, 3B2, 3C1, 3M6 ⁽²⁾
Installation altitude above mean sea level without current derating	m (ft)	<1000 (<3281)
Installation altitude above mean sea level with current derating of 1% per 100 m at altitudes higher than 1000 m	m (ft)	1000...3000 (3281...9843)
(1)	Limit values with flanged motor, see Flange Sizes for Limit Values, page 43	
(2)	Tested as per IEC 60068-2-6 and IEC 60068-2-27	

Ambient Conditions During Transportation and Storage

The environment during transportation and storage must be dry and free from dust.

Description	Unit	Value
Temperature	°C (°F)	-40...70 (-40...158)
Relative humidity (non-condensing)	%	≤75
Set of class combinations as per IEC 60721-3-2	-	IE 21

Flange Sizes for Limit Values

Limit values referring to this table relate to flanged motors with the following flange sizes:

Motor	Flange material	Flange size in [mm (in)]
BCH2MB	Aluminum	185 x 185 x 8 (7.28 x 7.28 x 0.31)
BCH2LD	Aluminum	250 x 250 x 12 (9.84 x 9.84 x 0.47)
BCH2-F	Aluminum	250 x 250 x 12 (9.84 x 9.84 x 0.47)
BCH2LH	Steel	300 x 300 x 20 (11.8 x 11.8 x 0.79)
BCH2-M	Steel	400 x 400 x 20 (15.7 x 15.7 x 0.79)
BCH2-R	Steel	550 x 550 x 20 (21.7 x 21.7 x 0.79)

Compatibility with Foreign Substances

The motor has been tested for compatibility with many known substances and with the latest available knowledge at the moment of the design. Nonetheless, you must perform a compatibility test before using a foreign substance.

Tightening Torque and Property Class of Screws

Housing screws	Unit	Tightening torque
M3 x 0.50	Nm (lb.in)	1 (8.85)
M4 x 0.70	Nm (lb.in)	2.9 (25.67)
M5 x 0.80	Nm (lb.in)	5.9 (52.22)
M6 x 1.00	Nm (lb.in)	9.9 (87.62)
M7 x 1.25	Nm (lb.in)	24 (212.40)
M8 x 1.50	Nm (lb.in)	49 (433.65)
Property class of the screws	H	8.8

Overload Characteristics Curves

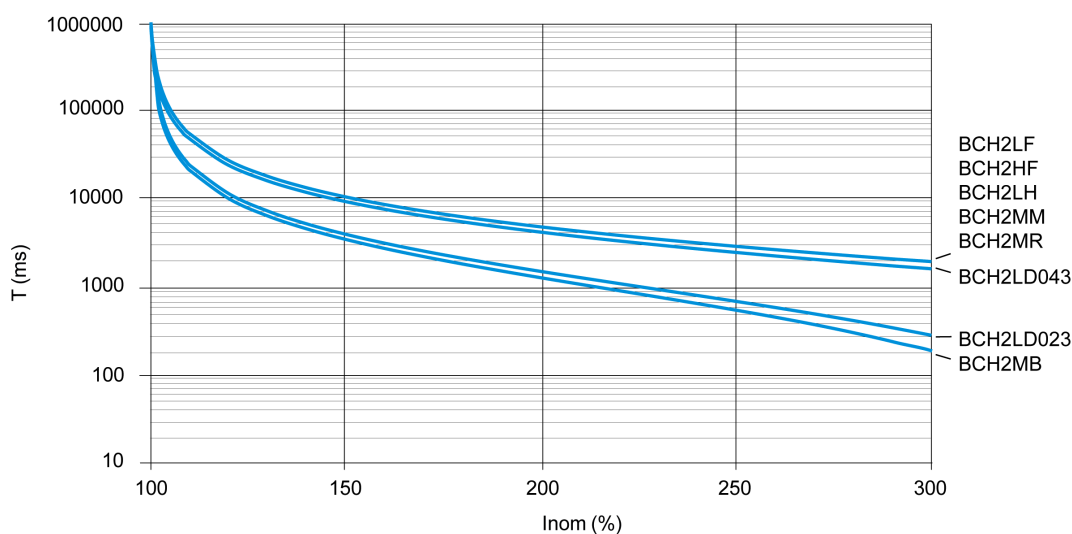

In order to make old MFOLD and new MFOLD be compatible, add new P parameter P2-71 to active new fold back algorithm. If you want to increase the

overload capacity, you can set MFOLD level by new parameter P2-73 (1~4). Default value is 1. The corresponding MFOLDT value is displayed in P2-72, page 193. See New Motor Fold Back Characteristics and Parameter Setting, page 259.

Encoder Technical Data

Overview

The drive can access the electronic nameplate via the electronic interface of the encoder for easy commissioning.

The signals meet the PELV requirements.

Depending on the motor reference, the motor are delivered with a single-turn encoder or a multi-turn encoder.

Single-Turn Encoder

Technical data

Description	Value
Measuring range absolute	1 revolution
Resolution in increments	Depending on evaluation
Accuracy of position	$\pm 0.044^\circ$
Supply voltage	4.1...5.25 Vdc
Maximum supply current	100 mA
Maximum permissible speed of rotation	6000 rpm
Maximum angular acceleration	100,000 rad/s ²

Multi-Turn Encoder

Technical data

Description	Value
Measuring range absolute	1 revolution
Resolution in increments	Depending on evaluation
Accuracy of position	$\pm 0.044^\circ$
Supply voltage	4.1...5.25 Vdc
Maximum supply current	40 μ A
Maximum permissible speed of rotation	6000 rpm
Maximum angular acceleration	100,000 rad/s ²
Battery nominal voltage	3.6 Vdc
Battery nominal current consumption while the encoder is not powered by the drive	20 μ A at standstill 40 μ A with rotating shaft
Battery life time (at 25 °C)	3 years

The multi-turn counting is preserved through power down by an external battery.

- For further information on the battery compartment connection, refer to the motor encoder connection, page 109.

- For further information on the battery replacement, refer to the maintenance of the motor, page 266.

BCH2MB Motor

BCH2MB Dimensions

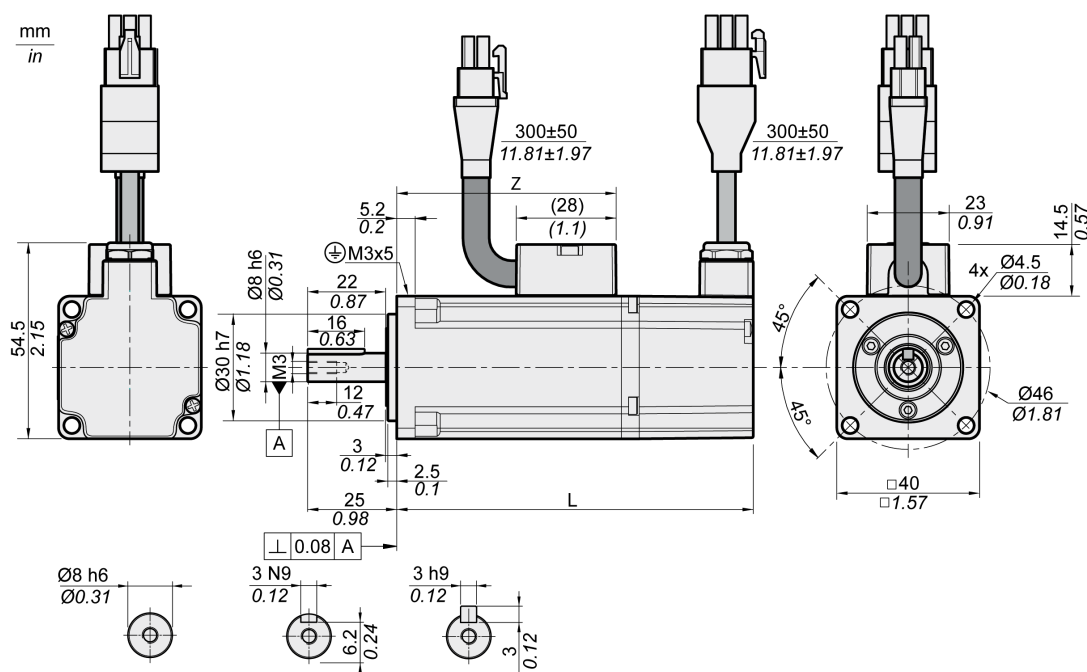

BCH2MB	Unit	A5	01
L (without holding brake)	mm (in)	82 (3.23)	100 (3.94)
L (with holding brake)	mm (in)	112 (4.41)	130 (5.12)
Z	mm (in)	43.5 (1.71)	61.5 (2.42)

BCH2MB Characteristics Table

BCH2MB ⁽¹⁾			A53	013
Technical data - general				
Continuous stall torque ⁽²⁾	M ₀	Nm	0.16	0.32
Peak torque	M _{max}	Nm	0.48	0.96
With supply voltage U _n = 230 Vac				
Nominal speed of rotation	n _N	rpm	3000	3000
Nominal torque	M _N	Nm	0.16	0.32
Nominal Current	I _N	A _{rms}	0.59	0.89
Nominal power	P _N	kW	0.05	0.10
Technical data - electrical				
Maximum winding voltage	U _{max}	Vac	255	255
Maximum winding voltage	U _{max}	Vdc	360	360
Maximum voltage to ground	–	Vac	255	255
Maximum Current	I _{max}	A _{rms}	1.8	2.7

BCH2MB ⁽¹⁾			A53	013	
Continuous stall current	I_0	A_{rms}	0.54	0.81	
Voltage constant ⁽³⁾	k_{EU-V}	V_{rms}	18	24	
Torque constant ⁽⁴⁾	k_t	Nm/A	0.30	0.40	
Winding resistance	R_{20U-V}	Ω	31.0	23.4	
Winding inductance	L_qU-V	mH	26.4	21.5	
Winding inductance	L_dU-V	mH	24.7	20.6	
Technical data - mechanical					
Maximum permissible speed of rotation	n_{max}	rpm	5000	5000	
Rotor inertia without brake	Hardware version RS 01 or RS 02	J_M	kgcm ²	0.054	0.075
	Hardware version RS 03			0.044	0.065
Rotor inertia with brake	Hardware version RS 01 or RS 02	J_M	kgcm ²	0.055	0.076
	Hardware version RS 03			0.045	0.066
Mass without brake	m	kg	0.40	0.56	
Mass with brake	m	kg	0.60	0.77	
Degree of protection of the shaft	–	–	IP 65	IP 65	
Degree of protection of the housing	–	–	IP 65	IP 65	
Technical data - holding brake					
Holding torque	–	Nm	0.32	0.32	
Nominal voltage	–	Vdc	24 +/-10%	24 +/-10%	
Nominal power (electrical pull-in power)	–	W	4.4	4.4	
(1)	Limit values with flanged motor: <ul style="list-style-type: none"> • Flange material: Aluminum • Flange size in mm (in): 185 x 185 x 8 (7.28 x 7.28 x 0.31) 				
(2)	M_0 = Continuous stall torque at 20 rpm and 100 % duty cycle; at speeds of rotation of <20 rpm the continuous stall torque is reduced to 87 %.				
(3)	RMS value at 1000 rpm and 20 °C (68 °F).				
(4)	At $n = 20$ rpm and 20 °C (68 °F).				

BCH2MB Curves

BCH2MBA53 + LXM28SUA5

Without shaft sealing ring

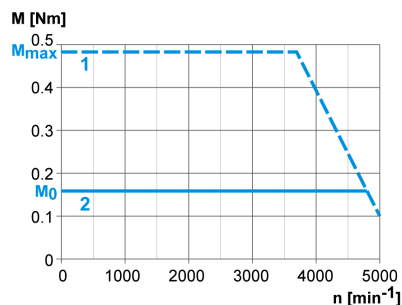

With shaft sealing ring

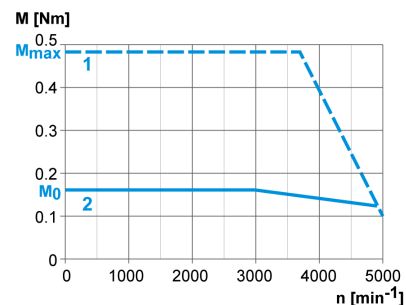

(1)	Peak torque
(2)	Continuous torque

BCH2MB013 + LXM28SU01

Without shaft sealing ring

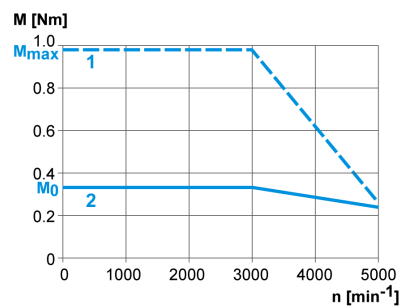

With shaft sealing ring

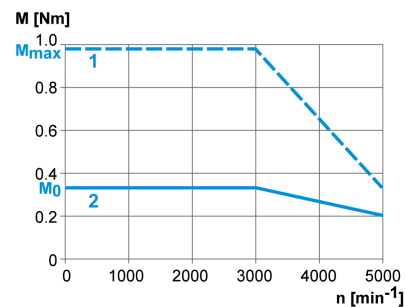

(1)	Peak torque
(2)	Continuous torque

BCH2LD Motor

BCH2LD Dimensions

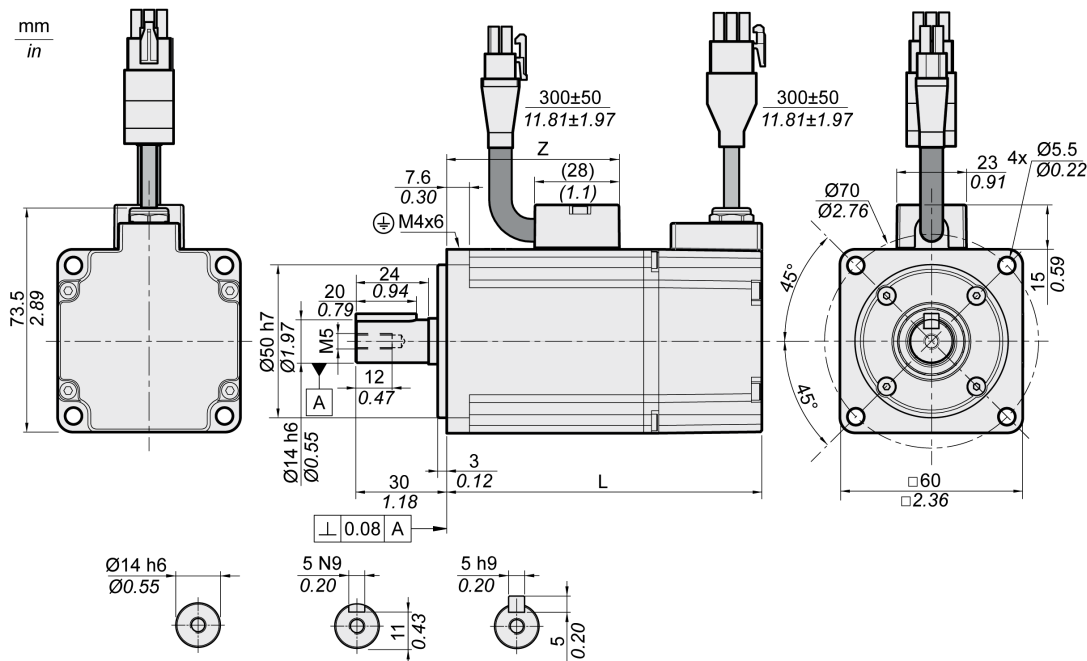

BCH2LD	Unit	02	04
L (without holding brake)	mm (in)	104 (4.09)	129 (5.08)
L (with holding brake)	mm (in)	140 (5.51)	165 (6.5)
Z	mm (in)	57 (2.24)	82 (3.23)

BCH2LD Characteristics Table

BCH2LD ⁽¹⁾			023	043
Technical data - general				
Continuous stall torque ⁽²⁾	M ₀	Nm	0.64	1.27
Peak torque	M _{max}	Nm	1.92	3.81
With supply voltage U _n = 230 Vac				
Nominal speed of rotation	n _N	rpm	3000	3000
Nominal torque	M _N	Nm	0.64	1.27
Nominal Current	I _N	A _{rms}	1.30	2.50
Nominal power	P _N	kW	0.20	0.40
Technical data - electrical				
Maximum winding voltage	U _{max}	Vac	255	255
Maximum winding voltage	U _{max}	Vdc	360	360
Maximum voltage to ground	–	Vac	255	255
Maximum Current	I _{max}	A _{rms}	4.5	7.8
Continuous stall current	I ₀	A _{rms}	1.11	2.19

BCH2LD ⁽¹⁾			023	043
Voltage constant ⁽³⁾	k_{EU-V}	V_{rms}	35	35
Torque constant ⁽⁴⁾	k_t	Nm/A	0.58	0.58
Winding resistance	R_{20U-V}	Ω	12.2	5.2
Winding inductance	L_{qU-V}	mH	24.8	12.5
Winding inductance	L_{dU-V}	mH	22.7	12.0
Technical data - mechanical				
Maximum permissible speed of rotation	n_{max}	rpm	5000	5000
Rotor inertia without brake	J_M	kgcm ²	0.15	0.26
Rotor inertia with brake	J_M	kgcm ²	0.16	0.27
Mass without brake	m	kg	1.02	1.45
Mass with brake	m	kg	1.50	2.00
Degree of protection of the shaft	–	–	IP 65	IP 65
Degree of protection of the housing	–	–	IP 65	IP 65
Technical data - holding brake				
Holding torque	–	Nm	1.3	1.3
Nominal voltage	–	Vdc	24 +/-10%	24 +/-10%
Nominal power (electrical pull-in power)	–	W	11.2	11.2
(1)	Limit values with flanged motor: <ul style="list-style-type: none"> Flange material: Aluminum Flange size in mm (in): 250 x 250 x 12 (9.84 x 9.84 x 0.47) 			
(2)	M_0 =Continuous stall torque at 20 rpm and 100 % duty cycle; at speeds of rotation of <20 rpm the continuous stall torque is reduced to 87 %			
(3)	RMS value at 1000 rpm and 20 °C (68 °F).			
(4)	At $n = 20$ rpm and 20 °C (68 °F).			

BCH2LD Curves

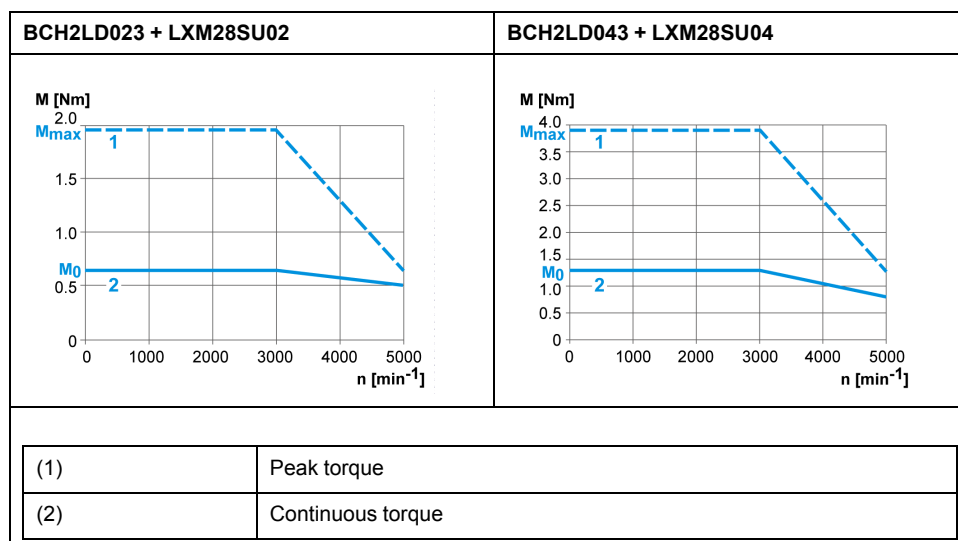

BCH2-F Motor

BCH2-F Dimensions

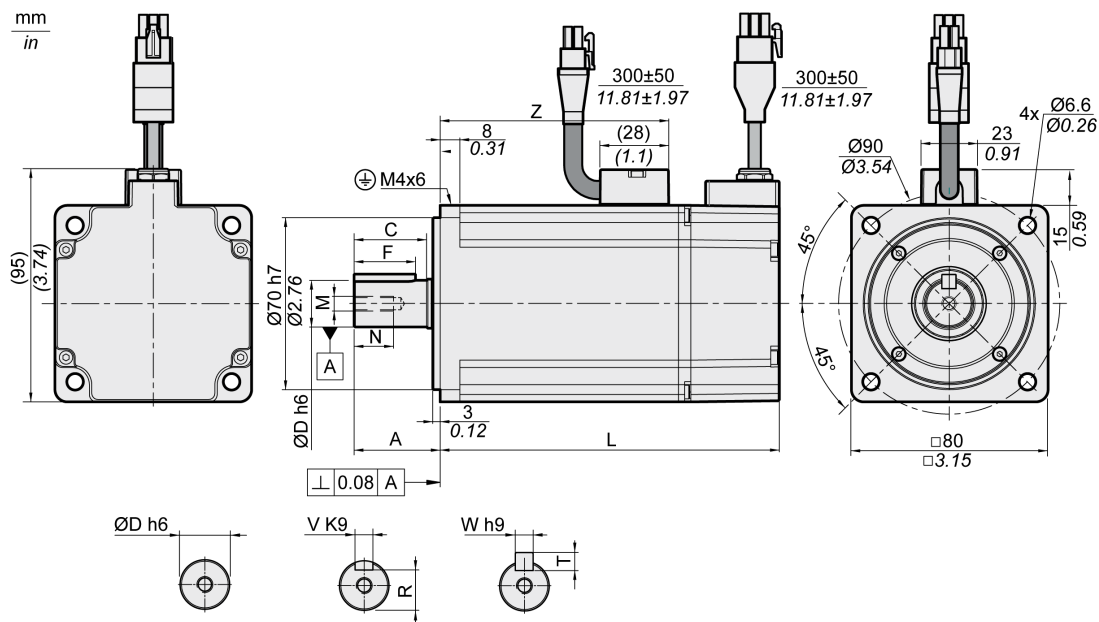

BCH2	Unit	LF04	HF07	LF07
L (without holding brake)	mm (in)	112 (4.41)	138 (5.43)	138 (5.43)
L (with holding brake)	mm (in)	152 (5.98)	178 (7.01)	178 (7.01)
A	mm (in)	30 (1.18)	35 (1.38)	35 (1.38)
C	mm (in)	24.5 (0.96)	29.5 (1.16)	29.5 (1.16)
D	mm (in)	14 (0.55)	19 (0.75)	19 (0.75)
F	mm (in)	20 (0.79)	25 (0.98)	25 (0.98)
M	-	M5	M6	M6
N	mm (in)	12 (0.47)	16 (0.63)	16 (0.63)
R	mm (in)	11 (0.43)	15.5 (0.61)	15.5 (0.61)
T	mm (in)	5 (0.2)	6 (0.24)	6 (0.24)
V	mm (in)	5 (0.2)	6 (0.24)	6 (0.24)
W	mm (in)	5 (0.2)	6 (0.24)	6 (0.24)
Z	mm (in)	68 (2.68)	93 (3.66)	93 (3.66)

BCH2-F Characteristics Table

BCH2 ⁽¹⁾			LF043	HF073	LF073
Technical data - general					
Continuous stall torque ⁽²⁾	M ₀	Nm	1.27	2.39	2.39
Peak torque	M _{max}	Nm	3.81	7.16	7.16
With supply voltage U _n = 230 Vac					
Nominal speed of rotation	n _N	rpm	3000	3000	3000

BCH2 ⁽¹⁾			LF043	HF073	LF073
Nominal torque	M _N	Nm	1.27	2.39	2.39
Nominal Current	I _N	A _{rms}	2.52	4.29	4.29
Nominal power	P _N	kW	0.40	0.75	0.75
Technical data - electrical					
Maximum winding voltage	U _{max}	Vac	255	255	255
Maximum winding voltage	U _{max}	Vdc	360	360	360
Maximum voltage to ground	–	Vac	255	255	255
Maximum Current	I _{max}	A _{rms}	7.8	13.5	13.5
Continuous stall current	I ₀	A _{rms}	2.29	4.01	4.01
Voltage constant ⁽³⁾	k _E U-V	V _{rms}	33.5	36	36
Torque constant ⁽⁴⁾	k _t	Nm/A	0.55	0.60	0.60
Winding resistance	R _{20U-V}	Ω	3.20	1.50	1.50
Winding inductance	L _{qu-v}	mH	12.0	6.6	6.6
Winding inductance	L _{dU-v}	mH	11.3	6.1	6.1
Technical data - mechanical					
Maximum permissible speed of rotation	n _{max}	rpm	5000	5000	5000
Rotor inertia without brake	J _M	kgcm ²	0.66	1.53	1.18
Rotor inertia with brake	J _M	kgcm ²	0.71	1.58	1.23
Mass without brake	m	kg	2.00	2.90	2.80
Mass with brake	m	kg	2.80	3.70	3.60
Degree of protection of the shaft	–	–	IP 65	IP 65	IP 65
Degree of protection of the housing	–	–	IP 65	IP 65	IP 65
Technical data - holding brake					
Holding torque	–	Nm	2.5	2.5	2.5
Nominal voltage	–	Vdc	24 +/-10%	24 +/-10%	24 +/-10%
Nominal power (electrical pull-in power)	–	W	10.2	10.2	10.2
(1)	Limit values with flanged motor: <ul style="list-style-type: none"> • Flange material: Aluminum • Flange size in mm (in): 250 x 250 x 12 (9.84 x 9.84 x 0.47) 				
(2)	M ₀ =Continuous stall torque at 20 rpm and 100 % duty cycle; at speeds of rotation of <20 rpm the continuous stall torque is reduced to 87 %				
(3)	RMS value at 1000 rpm and 20 °C (68 °F).				
(4)	At n = 20 rpm and 20 °C (68 °F).				

BCH2-F Curves

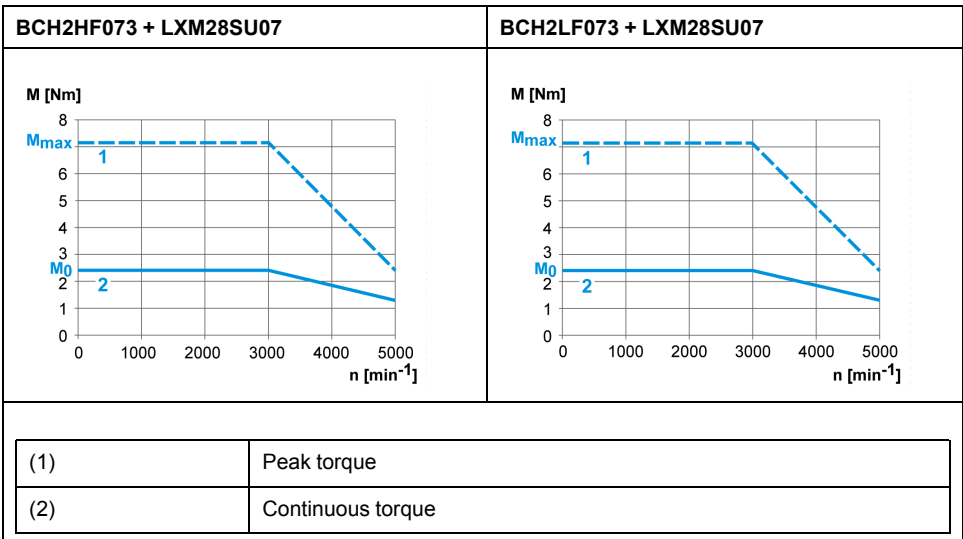
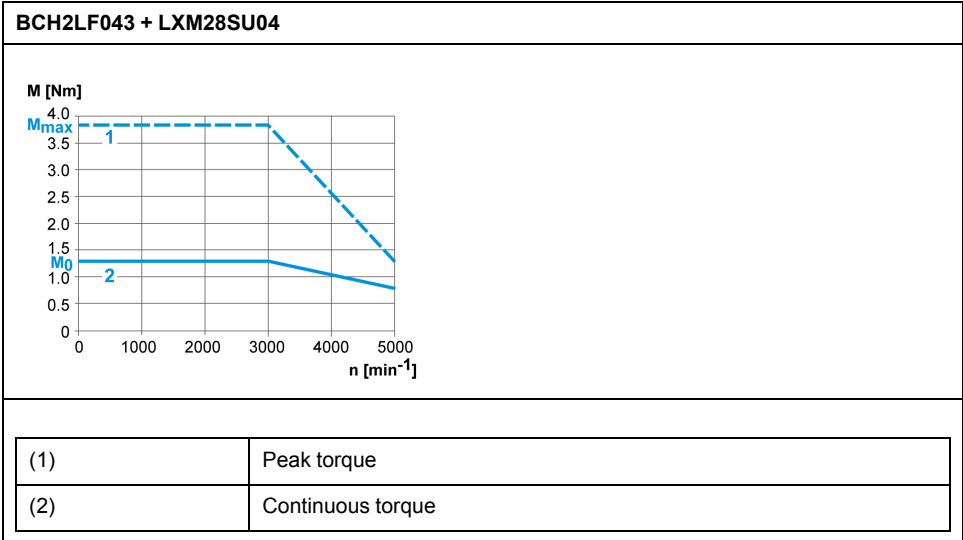

BCH2LH Motor

BCH2LH Dimensions

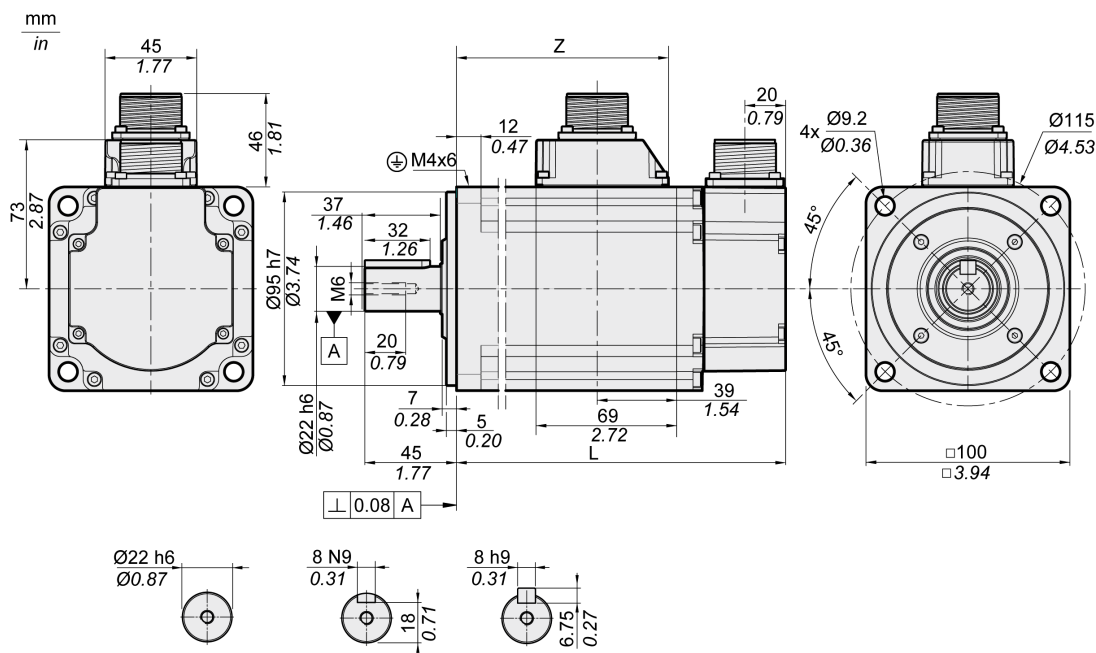

BCH2LH	Unit	103	203
L (without holding brake)	mm (in)	153.5 (6.04)	198.5 (7.81)
L (with holding brake)	mm (in)	180.5 (7.11)	225.5 (8.88)
Z	mm (in)	96 (3.78)	141 (5.55)

BCH2LH Characteristics Table

BCH2LH ⁽¹⁾			103	203
Technical data - general				
Continuous stall torque ⁽²⁾	M ₀	Nm	3.18	6.37
Peak torque	M _{max}	Nm	9.54	19.11
With supply voltage U _n = 230 Vac				
Nominal speed of rotation	n _N	rpm	3000	3000
Nominal torque	M _N	Nm	3.18	6.37
Nominal Current	I _N	A _{rms}	6.64	10.27
Nominal power	P _N	kW	1.00	2.00
Technical data - electrical				
Maximum winding voltage	U _{max}	Vac	255	255
Maximum winding voltage	U _{max}	Vdc	360	360
Maximum voltage to ground	–	Vac	255	255
Maximum Current	I _{max}	A _{rms}	20.0	35.0
Continuous stall current	I ₀	A _{rms}	5.83	9.87

BCH2LH ⁽¹⁾			103	203
Voltage constant ⁽³⁾	k_E U-V	V_{rms}	33	39
Torque constant ⁽⁴⁾	k_t	Nm/A	0.55	0.65
Winding resistance	R_{20} U-V	Ω	0.67	0.36
Winding inductance	L_q U-V	mH	4.3	2.6
Winding inductance	L_d U-V	mH	4.20	2.59
Technical data - mechanical				
Maximum permissible speed of rotation	n_{max}	rpm	5000	5000
Rotor inertia without brake	J_M	kgcm ²	2.39	4.27
Rotor inertia with brake	J_M	kgcm ²	2.44	4.34
Mass without brake	m	kg	4.60	6.70
Mass with brake	m	kg	5.10	7.20
Degree of protection of the shaft	-	-	IP 65	IP 65
Degree of protection of the housing	-	-	IP 65	IP 65
Technical data - holding brake				
Holding torque	-	Nm	6.5	6.5
Nominal voltage	-	Vdc	24 +/-10%	24 +/-10%
Nominal power (electrical pull-in power)	-	W	10.4	10.4
(1)	Limit values with flanged motor: <ul style="list-style-type: none"> Flange material: Steel Flange size in mm (in): 300 x 300 x 20 (11.8 x 11.8 x 0.79) 			
(2)	M_0 =Continuous stall torque at 20 rpm and 100 % duty cycle; at speeds of rotation of <20 rpm the continuous stall torque is reduced to 87 %			
(3)	RMS value at 1000 rpm and 20 °C (68 °F).			
(4)	At n = 20 rpm and 20 °C (68 °F).			

BCH2LH Curves

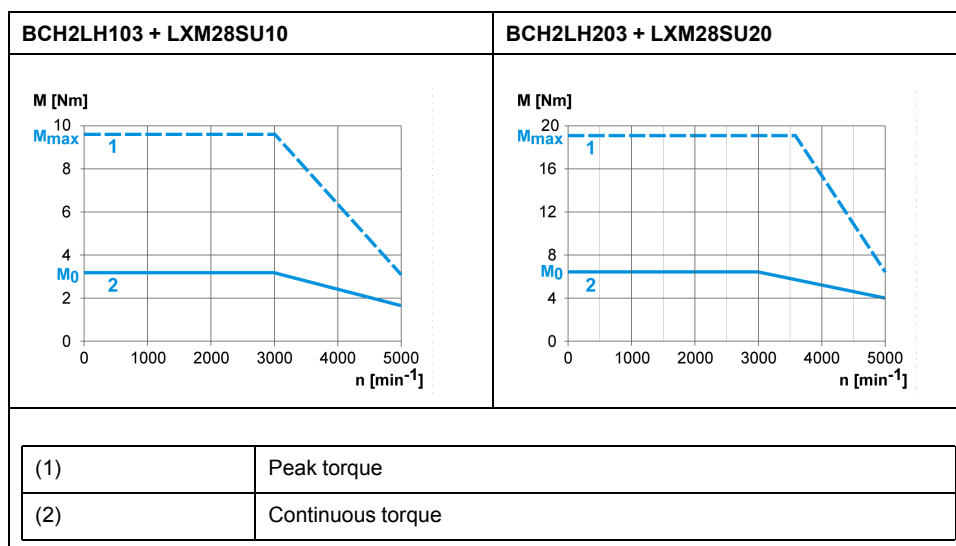

BCH2-M Motor

BCH2-M Dimensions

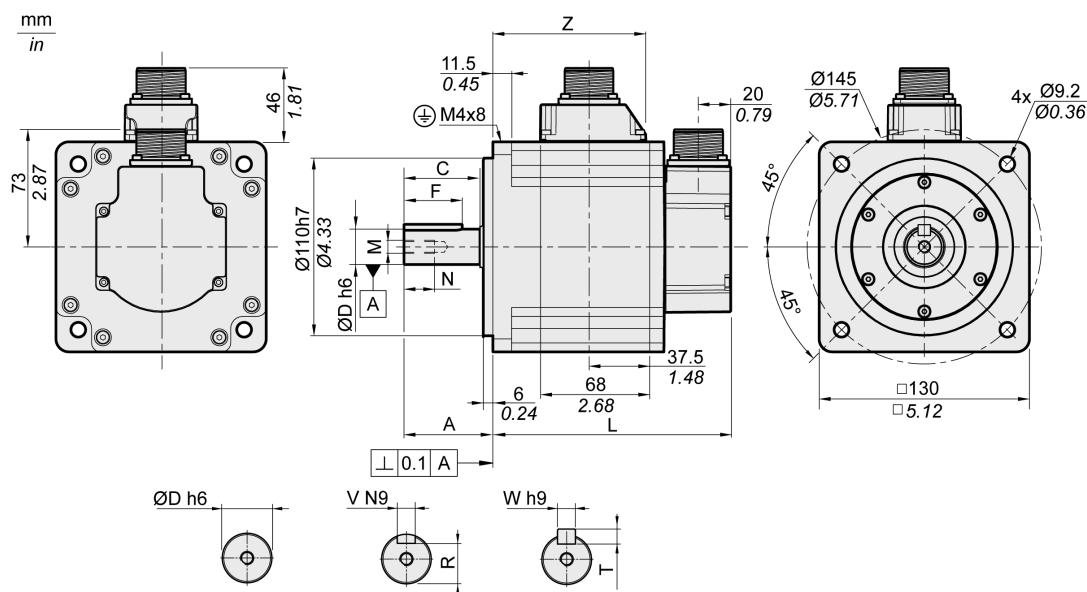

BCH2-M	Unit	08	03, 05, 06, 10	09, 15	20
L (without holding brake)	mm (in)	187 (7.36)	147 (5.79)	163 (6.42)	187 (7.36)
L (with holding brake)	mm (in)	216 (8.5)	176 (6.93)	192 (7.56)	216 (8.5)
A	mm (in)	48 (1.89)	55 (2.17)	55 (2.17)	55 (2.17)
C	mm (in)	40 (1.57)	47 (1.85)	47 (1.85)	47 (1.85)
D	mm (in)	19 (0.75)	22 (0.87)	22 (0.87)	22 (0.87)
F	mm (in)	25 (0.98)	36 (1.42)	36 (1.42)	36 (1.42)
M	-	M6	M8	M8	M8
N	mm (in)	16 (0.63)	19 (0.75)	19 (0.75)	19 (0.75)
R	mm (in)	15.5 (0.61)	18 (0.71)	18 (0.71)	18 (0.71)
T	mm (in)	6 (0.24)	7 (0.28)	7 (0.28)	7 (0.28)
V	mm (in)	6 (0.24)	8 (0.31)	8 (0.31)	8 (0.31)
W	mm (in)	6 (0.24)	8 (0.31)	8 (0.31)	8 (0.31)
Z	mm (in)	134.5 (5.30)	94.5 (3.72)	110.5 (4.35)	134.5 (5.30)

BCH2-M Characteristics Table

BCH2 ⁽¹⁾			MM052	MM031	MM102	HM102	MM081
Technical data - general							
Continuous stall torque ⁽²⁾	M ₀	Nm	2.39	2.86	4.77	4.77	5.39
Peak torque	M _{max}	Nm	7.16	8.59	14.30	14.30	13.80
With supply voltage U _n = 230 Vac							
Nominal speed of rotation	n _N	rpm	2000	1000	2000	2000	1500
Nominal torque	M _N	Nm	2.39	2.86	4.77	4.77	5.39
Nominal Current	I _N	A _{rms}	3.24	2.09	6.29	6.29	6.29

BCH2 ⁽¹⁾			MM052	MM031	MM102	HM102	MM081
Nominal power	P _N	kW	0.50	0.30	1.00	1.00	0.85
Technical data - electrical							
Maximum winding voltage	U _{max}	Vac	255	255	255	255	255
Maximum winding voltage	U _{max}	Vdc	360	360	360	360	360
Maximum voltage to ground	–	Vac	255	255	255	255	255
Maximum Current	I _{max}	A _{rms}	9.5	6.0	20.0	20.0	15.0
Continuous stall current	I ₀	A _{rms}	2.89	1.88	5.77	5.77	5.62
Voltage constant ⁽³⁾	k _{EU-V}	V _{rms}	50	92	50	50	58
Torque constant ⁽⁴⁾	k _t	Nm/A	0.83	1.52	0.83	0.83	0.96
Winding resistance	R _{20U-V}	Ω	0.74	2.08	0.74	0.74	0.42
Winding inductance	L _{qU-V}	mH	7.84	26.25	7.84	7.84	4.70
Winding inductance	L _{dU-V}	mH	7.14	23.91	7.14	7.14	4.30
Technical data - mechanical							
Maximum permissible speed of rotation	n _{max}	rpm	3000	2000	3000	3000	3000
Rotor inertia without brake	J _M	kgcm ²	6.62	6.62	6.62	8.40	13.49
Rotor inertia with brake	J _M	kgcm ²	6.90	6.90	6.90	8.79	14.09
Mass without brake	m	kg	7.00	7.00	7.00	7.10	9.60
Mass with brake	m	kg	8.20	8.20	8.20	8.30	10.90
Degree of protection of the shaft	–	–	IP 65	IP 54	IP 65	IP 65	IP 54
Degree of protection of the housing	–	–	IP 65	IP 65	IP 65	IP 65	IP 65
Technical data - holding brake							
Holding torque	–	Nm	9.6	9.6	9.6	9.6	9.6
Nominal voltage	–	Vdc	24 +/-10%	24 +/-10%	24 +/-10%	24 +/-10%	24 +/-10%
Nominal power (electrical pull-in power)	–	W	19.7	19.7	19.7	19.7	19.7
(1)	Limit values with flanged motor: <ul style="list-style-type: none"> • Flange material: Steel • Flange size in mm (in): 400 x 400 x 20 (15.7 x 15.7 x 0.79) 						
(2)	M ₀ =Continuous stall torque at 20 rpm and 100 % duty cycle; at speeds of rotation of <20 rpm the continuous stall torque is reduced to 87 %						
(3)	RMS value at 1000 rpm and 20 °C (68 °F).						
(4)	At n = 20 rpm and 20 °C (68 °F).						

BCH2 ⁽¹⁾			MM061	MM091	MM152	MM202
Technical data - general						
Continuous stall torque ⁽²⁾	M ₀	Nm	5.73	8.59	7.16	9.55
Peak torque	M _{max}	Nm	17.19	25.77	21.48	28.65
With supply voltage U _n = 230 Vac						
Nominal speed of rotation	n _N	rpm	1000	1000	2000	2000
Nominal torque	M _N	Nm	5.73	8.59	7.16	9.55
Nominal Current	I _N	A _{rms}	4.10	6.15	6.74	11.25
Nominal power	P _N	kW	0.60	0.90	1.50	2.00
Technical data - electrical						

BCH2 ⁽¹⁾			MM061	MM091	MM152	MM202
Maximum winding voltage	U_{\max}	Vac	255	255	255	255
Maximum winding voltage	U_{\max}	Vdc	360	360	360	360
Maximum voltage to ground	–	Vac	255	255	255	255
Maximum Current	I_{\max}	A_{rms}	13.5	20.0	21.0	33.0
Continuous stall current	I_0	A_{rms}	3.77	5.64	6.18	9.95
Voltage constant ⁽³⁾	$k_{E\text{U-V}}$	V_{rms}	92	92	70	58
Torque constant ⁽⁴⁾	k_t	Nm/A	1.52	1.52	1.16	0.96
Winding resistance	$R_{20\text{U-V}}$	Ω	2.08	1.22	0.64	0.42
Winding inductance	$L_{q\text{U-V}}$	mH	26.25	16.40	7.20	4.70
Winding inductance	$L_{d\text{U-V}}$	mH	23.91	14.90	6.40	4.30
Technical data - mechanical						
Maximum permissible speed of rotation	n_{\max}	rpm	2000	2000	3000	3000
Rotor inertia without brake	J_M	kgcm ²	6.62	9.69	9.69	13.49
Rotor inertia with brake	J_M	kgcm ²	6.90	9.99	9.99	14.09
Mass without brake	m	kg	7.00	7.60	7.60	9.70
Mass with brake	m	kg	8.20	8.80	8.80	11.00
Technical data - holding brake						
Holding torque	–	Nm	9.6	9.6	9.6	9.6
Nominal voltage	–	Vdc	24 +/-10%	24 +/-10%	24 +/-10%	24 +/-10%
Nominal power (electrical pull-in power)	–	W	19.7	19.7	19.7	19.7
(1)	Limit values with flanged motor: <ul style="list-style-type: none"> Flange material: Steel Flange size in mm (in): 400 x 400 x 20 (15.7 x 15.7 x 0.79) 					
(2)	M_0 =Continuous stall torque at 20 rpm and 100 % duty cycle; at speeds of rotation of <20 rpm the continuous stall torque is reduced to 87 %					
(3)	RMS value at 1000 rpm and 20 °C (68 °F).					
(4)	At n = 20 rpm and 20 °C (68 °F).					

BCH2-M Curves

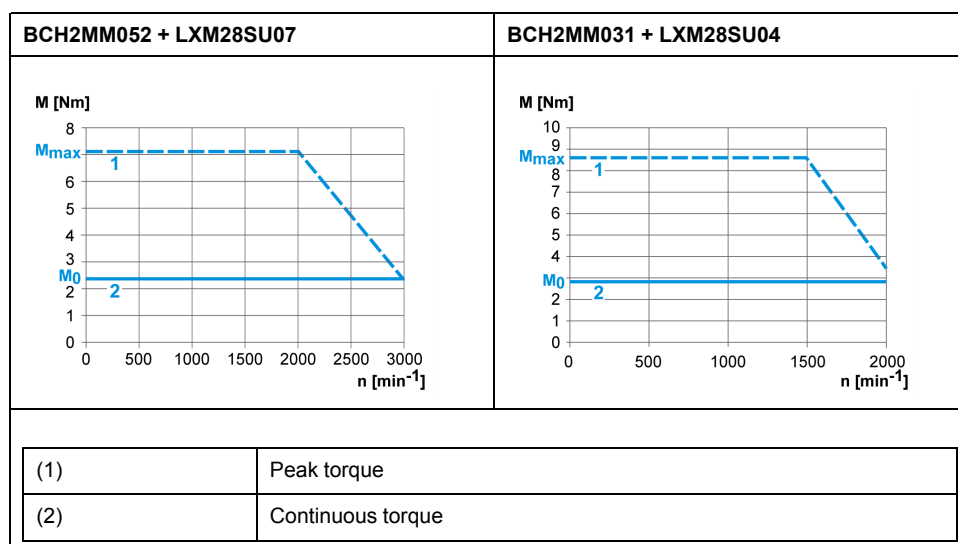

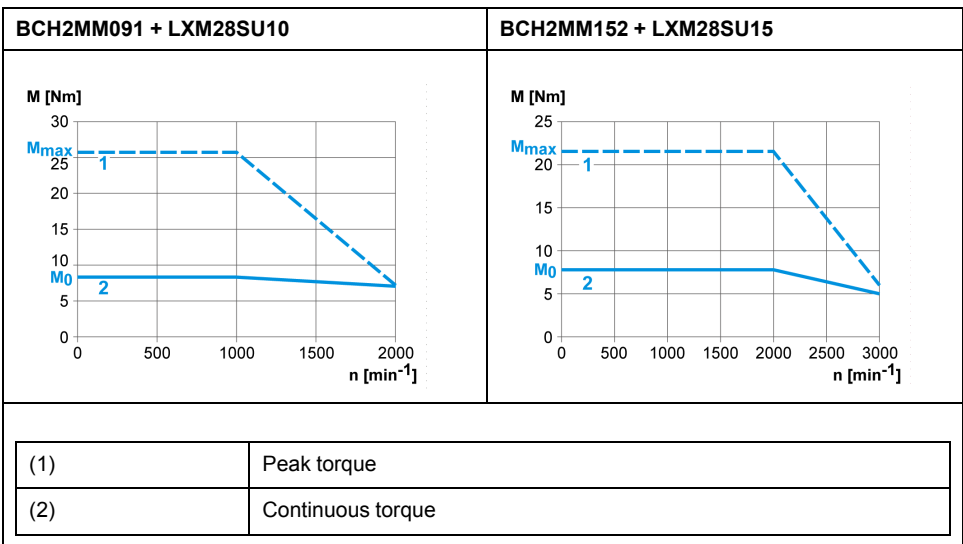
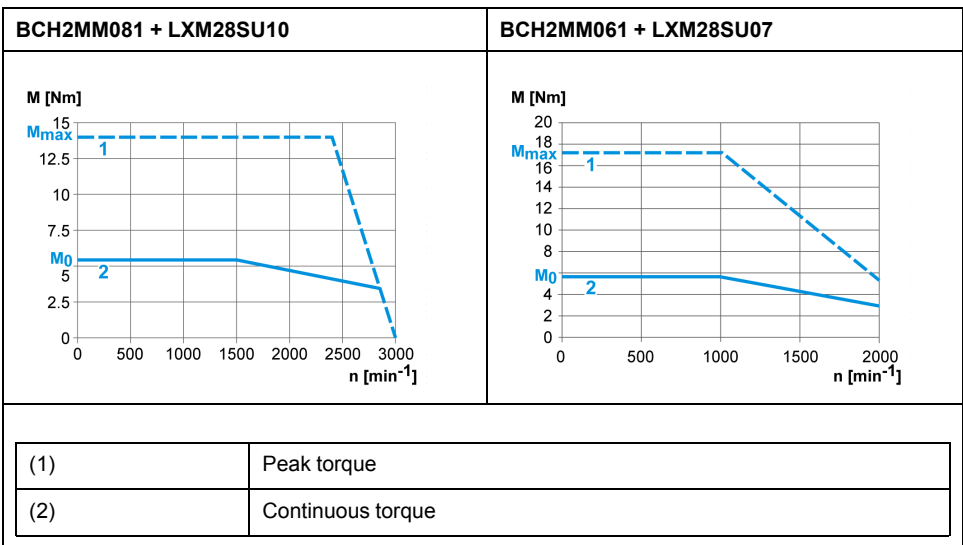
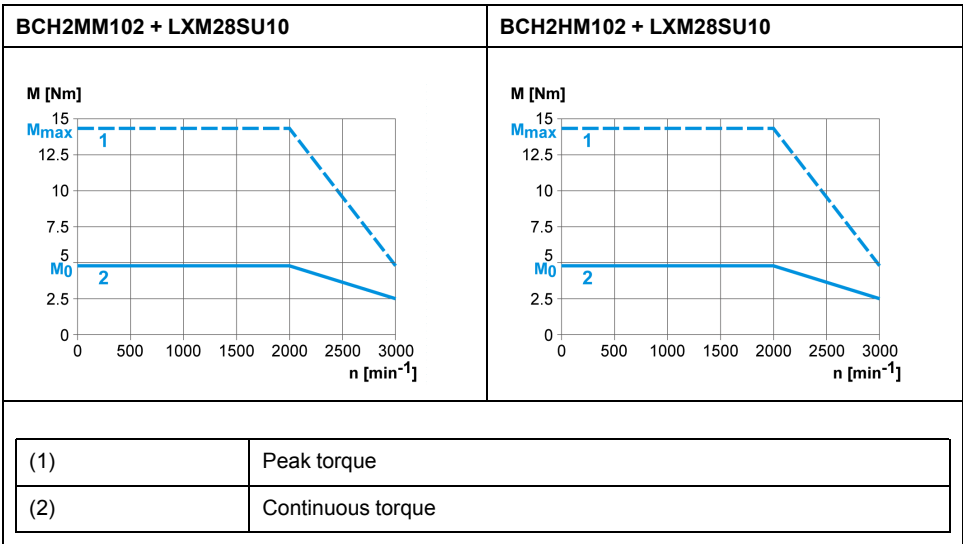

BCH2MM202 + LXM28SU20

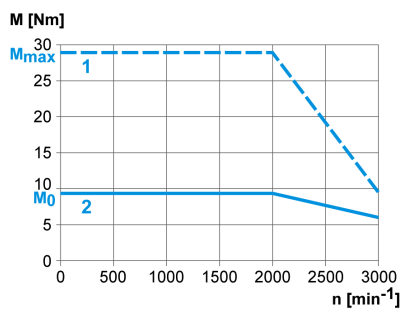

(1)	Peak torque
(2)	Continuous torque

BCH2-R Motor

BCH2-R Dimensions

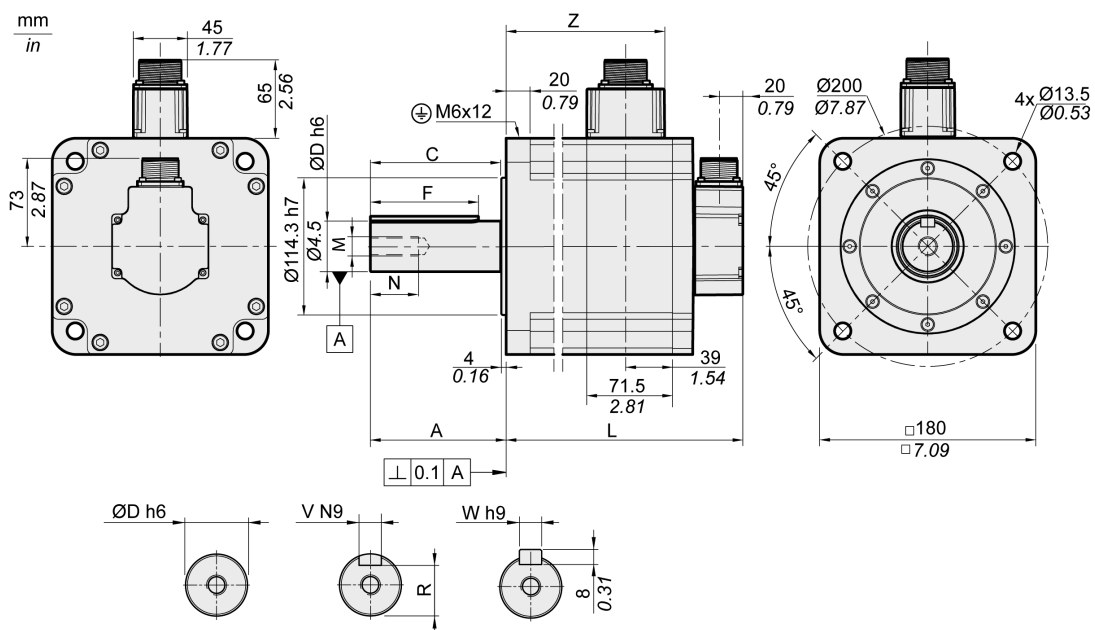

BCH2-R	Unit	20	30, 35	45
L (without holding brake)	mm (in)	168 (6.61)	201 (7.91)	234 (9.21)
L (with holding brake)	mm (in)	203 (7.99)	236 (9.29)	269 (10.59)
A	mm (in)	79 (3.11)		
C	mm (in)	73 (2.87)		
D	mm (in)	35 (1.38)		
F	mm (in)	63 (2.48)		
M	-	M12		
N	mm (in)	28 (1.10)		
R	mm (in)	30 (1.18)		
V	mm (in)	10 (0.39)		

BCH2-R	Unit	20	30, 35	45
W	mm (in)	10 (0.39)		
Z	mm (in)	103 (4.06)	136 (5.35)	169 (6.65)

BCH2-R Characteristics Table

BCH2MR202/301/302, BCH2HR202 technical data

BCH2 ⁽¹⁾			MR202	HR202	MR302	MR301
Technical data - general						
Continuous stall torque ⁽²⁾	M ₀	Nm	9.55	9.55	14.32	19.10
Peak torque	M _{max}	Nm	28.65	28.65	42.97	57.29
With supply voltage U _n = 230 Vac						
Nominal speed of rotation	n _N	rpm	2000	2000	2000	1500
Nominal torque	M _N	Nm	9.55	9.55	14.32	19.10
Nominal Current	I _N	A _{rms}	9.6	9.6	18.8	18.8
Nominal power	P _N	kW	2.00	2.00	3.00	3.00
Technical data - electrical						
Maximum winding voltage	U _{max}	Vac	255	255	255	255
Maximum winding voltage	U _{max}	Vdc	360	360	360	360
Maximum voltage to ground	–	Vac	255	255	255	255
Maximum Current	I _{max}	A _{rms}	35.5	35.5	56.0	61.0
Continuous stall current	I ₀	A _{rms}	8.75	8.75	16.33	16.49
Voltage constant ⁽³⁾	k _E U-V	V _{rms}	66	66	53	70
Torque constant ⁽⁴⁾	k _t	Nm/A	1.09	1.09	0.88	1.16
Winding resistance	R _{20U-V}	Ω	0.572	0.572	0.168	0.234
Winding inductance	L _{qU-V}	mH	6.70	6.70	2.88	3.78
Winding inductance	L _{dU-V}	mH	6.10	6.10	2.71	3.45
Technical data - mechanical						
Maximum permissible speed of rotation	n _{max}	rpm	3000	3000	3000	3000
Rotor inertia without brake	J _M	kgcm ²	26.49	34.67	53.55	53.55
Rotor inertia with brake	J _M	kgcm ²	26.99	36.17	54.09	54.09
Mass without brake	m	kg	13.00	14.30	18.50	18.50
Mass with brake	m	kg	18.00	19.30	23.00	23.00
Degree of protection of the shaft	–	–	IP 65	IP 65	IP 65	IP 54
Degree of protection of the housing	–	–	IP 65	IP 65	IP 65	IP 65
Technical data - holding brake						
Holding torque	–	Nm	48	48	48	48
Nominal voltage	–	Vdc	24 +/-10%	24 +/-10%	24 +/-10%	24 +/-10%

BCH2 ⁽¹⁾			MR202	HR202	MR302	MR301
Nominal power (electrical pull-in power)	–	W	49.6	49.6	49.6	49.6
(1)	Limit values with flanged motor: <ul style="list-style-type: none"> Flange material: Steel Flange size in mm (in): 550 x 550 x 20 (21.7 x 21.7 x 0.79) 					
(2)	M_0 =Continuous stall torque at 20 rpm and 100 % duty cycle; at speeds of rotation of <20 rpm the continuous stall torque is reduced to 87 %					
(3)	RMS value at 1000 rpm and 20 °C (68 °F).					
(4)	At n = 20 rpm and 20 °C (68 °F).					

BCH2MR352/451 technical data

BCH2 ⁽¹⁾			MR352	MR451
Technical data - general				
Continuous stall torque ⁽²⁾	M_0	Nm	16.70	28.65
Peak torque	M_{max}	Nm	50.30	71.62
With supply voltage $U_n = 230$ Vac				
Nominal speed of rotation	n_N	rpm	2000	1500
Nominal torque	M_N	Nm	16.70	28.65
Nominal Current	I_N	A_{rms}	19.3	22.8
Nominal power	P_N	kW	3.50	4.50
Technical data - electrical				
Maximum winding voltage	U_{max}	Vac	255	255
Maximum winding voltage	U_{max}	Vdc	360	360
Maximum voltage to ground	–	Vac	255	255
Maximum Current	I_{max}	A_{rms}	61.0	61.0
Continuous stall current	I_0	A_{rms}	16.83	19.68
Voltage constant ⁽³⁾	$k_E U-V$	V_{rms}	60	88
Torque constant ⁽⁴⁾	k_t	Nm/A	0.99	1.46
Winding resistance	R_{20U-V}	Ω	0.168	0.199
Winding inductance	$L_q U-V$	mH	2.80	4.00
Winding inductance	$L_d U-V$	mH	2.57	3.80
Technical data - mechanical				
Maximum permissible speed of rotation	n_{max}	rpm	3000	3000
Rotor inertia without brake	J_M	kgc-m ²	53.55	73.31
Rotor inertia with brake	J_M	kgc-m ²	54.09	72.99
Mass without brake	m	kg	18.50	23.64
Mass with brake	m	kg	23.00	28.00
Technical data - holding brake				
Holding torque	–	Nm	48	48
Nominal voltage	–	Vdc	24 +/-10%	24 +/-10%

BCH2 ⁽¹⁾			MR352	MR451
Nominal power (electrical pull-in power)	–	W	49.6	49.6
(1)	Limit values with flanged motor: <ul style="list-style-type: none"> Flange material: Steel Flange size in mm (in): 550 x 550 x 20 (21.7 x 21.7 x 0.79) 			
(2)	M_0 =Continuous stall torque at 20 rpm and 100 % duty cycle; at speeds of rotation of <20 rpm the continuous stall torque is reduced to 87 %			
(3)	RMS value at 1000 rpm and 20 °C (68 °F).			
(4)	At n = 20 rpm and 20 °C (68 °F).			

BCH2-R Curves

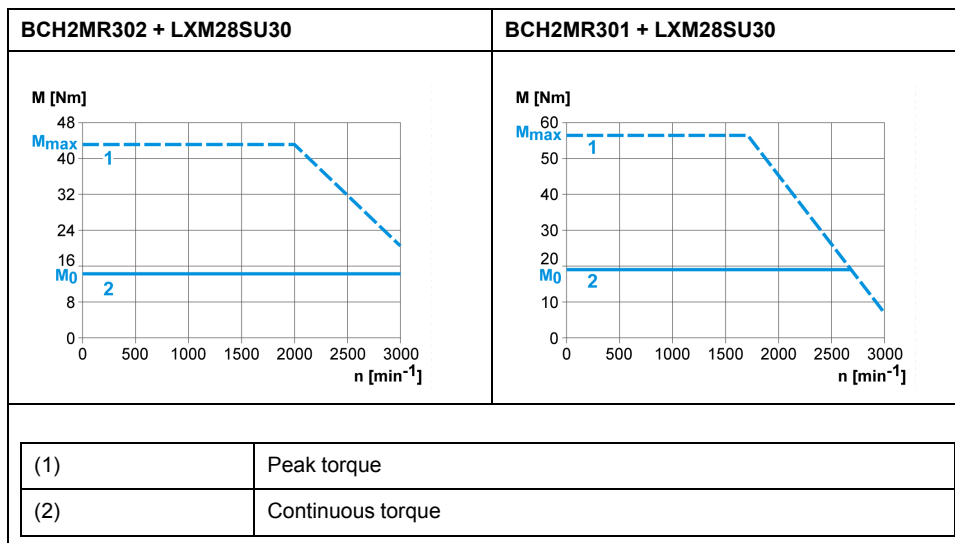
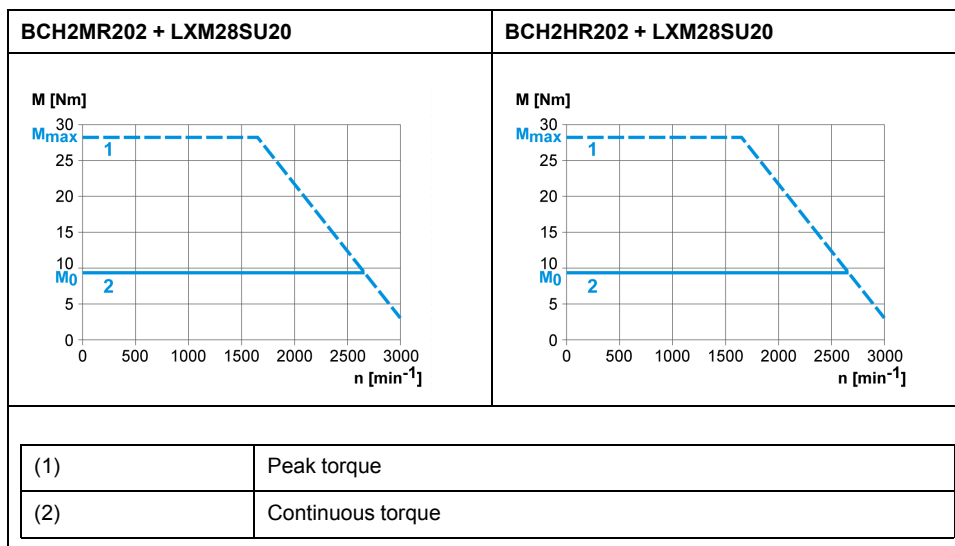

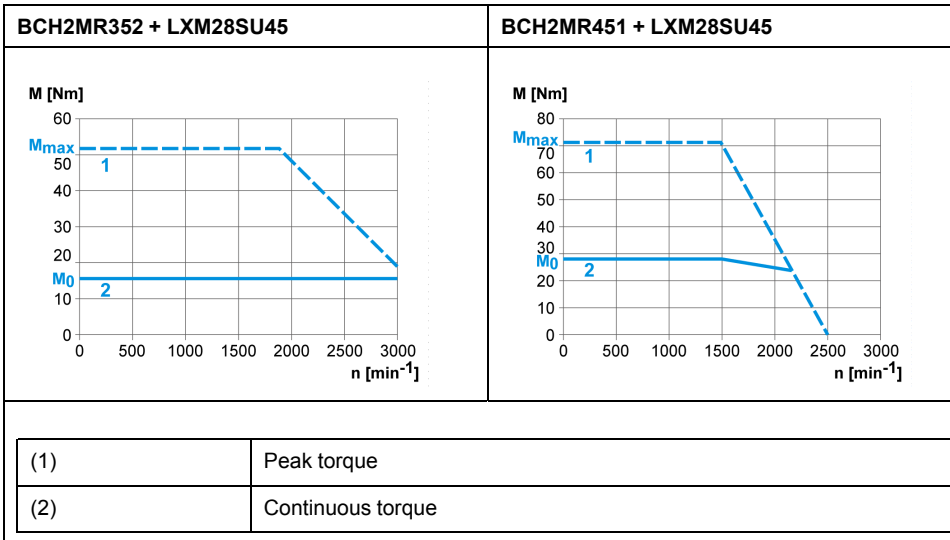

Accessories and Spare Parts

What's in This Chapter

Commissioning Tools.....	65
Connectors and Adapters	65
External Mains Filters	66
DC Bus Accessories.....	66
Application Nameplate.....	66
Ethernet Shielded Twisted-pair Cables.....	66
SERCOS III Cables with Connectors	67
Motor Cables	67
Encoder Cables and Accessories	68
Signal Cables.....	68
Signal Cable for Safety Function STO	68
External Braking Resistors and Holding Brake Controller.....	68
Circuit Breakers	69
Motor Protection Switches and Power Contactors.....	69

Commissioning Tools

Description	Reference
Commissioning software LXM28 DTM Library, can be downloaded at: www.se.com	-
SDDML Description file, can be downloaded at: www.se.com	-
PC connection kit, serial connection between drive and PC, USB-A to RJ45	TCSMCNAM3M002P
Multi-Loader, device for copying the parameter settings to a PC or to another drive	VW3A8121
Connection cable for Multi-Loader	VW3A8126
Modbus cable, 1 m (3.28 ft), 2 x RJ45	VW3A8306R10

Connectors and Adapters

Description	Drive Type	Reference	
Connector kit for logic supply and power stage supply (CN5), braking resistor (CN7), and motor (CN8)	LXM28SUA5, LXM28SU01, LXM28SU02, LXM28SU04, LXM28SU07, LXM28SU10, LXM28SU15	VW3M4C21	
	LXM28SU20	VW3M4C23	
	LXM28SU30, LXM28SU45	VW3M4C24	
Cable shield connection plate, clamps, and screws	LXM28SUA5, LXM28SU01, LXM28SU02, LXM28SU04, LXM28SU07, LXM28SU10, LXM28SU15	VW3M2C31	
	LXM28SU20	VW3M2C33	
	LXM28SU30, LXM28SU45	VW3M2C34	
	Interface adapter for CN1, connector with 0.5 m (1.64 ft) cable and connection module with screw terminals for DIN rail mounting	VW3M1C13	
Connector kit for motor	Motor end plastic connector	Without holding brake	VW3M5D1A
		With holding brake	VW3M5D1F
	Motor end MIL connector	With holding brake, size 100 ... 130	VW3M5D2A
		With holding brake, size 180	VW3M5D2B

Description		Drive Type	Reference
		For 8 mm ² (AWG8) up to 16 mm ² (AWG16) with holding brake, size 180	VW3M5D2C
		Device end IEEE1394 connector	VW3M8D2A
	Motor end flying leads	Device end IEEE1394 connector	VW3M8D1A

External Mains Filters

Description		Reference
Mains filter single-phase; 115/230 Vac	9 A	VW3A4420
	16 A	VW3A4421
	23 A	VW3A4426
Mains filter three-phase; 208/400/480 Vac	15 A	VW3A4422
	25 A	VW3A4423
	47 A	VW3A4424

DC Bus Accessories

Description		Reference
DC bus connection cable, 2 x 6 mm ² (2 x AWG 10)	Pre-assembled, 0.1 m (0.33 ft), 5 pieces	VW3M7101R01
	Twisted Pair, shielded, 15 m (49.2 ft)	VW3M7102R150
DC bus connector kit, connector housing, and crimp contacts for 3 ... 6 mm ² (AWG 12 ... 10), 10 pieces		VW3M2207

A crimping tool is required for the crimp contacts of the connector kit.

Manufacturer: Tyco Electronics, Heavy Head Hand Tool, Tool Pt. No 180250

Application Nameplate

Description	Reference
Application nameplate to be clipped onto the top of the drive, size 38.5 mm (1.52 in) x 13 mm (0.51 in), 50 pieces	VW3M2501

Ethernet Shielded Twisted-pair Cables

Description		Reference	
2 x RJ45, shielded twisted-pair cable	-	2 m (6.56 ft)	490NTW00002
		5 m (16.4 ft)	490NTW00005
		12 m (39.37 ft)	490NTW00012
	With UL and CSA 22.1 certification	2 m (6.56 ft)	490NTW00002U
		5 m (16.4 ft)	490NTW00005U
		12 m (39.37 ft)	490NTW00012U

SERCOS III Cables with Connectors

Description	Reference
SERCOS III cable, 2 x RJ45, shielded cable, Twisted Pair, 0.5 m (1.64 ft)	VW3E5001R005
SERCOS III cable, 2 x RJ45, shielded cable, Twisted Pair, 1 m (3.28 ft)	VW3E5001R010
SERCOS III cable, 2 x RJ45, shielded cable, Twisted Pair, 1.5 m (4.92 ft)	VW3E5001R015
SERCOS III cable, 2 x RJ45, shielded cable, Twisted Pair, 2 m (6.56 ft)	VW3E5001R020
SERCOS III cable, 2 x RJ45, shielded cable, Twisted Pair, 3 m (9.84 ft)	VW3E5001R030
SERCOS III cable, 2 x RJ45, shielded cable, Twisted Pair, 5 m (16.4 ft)	VW3E5001R050
SERCOS III cable, 2 x RJ45, shielded cable, Twisted Pair, 10 m (32.8 ft)	VW3E5001R100
SERCOS III cable, 2 x RJ45, shielded cable, Twisted Pair, 15 m (49.2 ft)	VW3E5001R150
SERCOS III cable, 2 x RJ45, shielded cable, Twisted Pair, 20 m (65.6 ft)	VW3E5001R200
SERCOS III cable, 2 x RJ45, shielded cable, Twisted Pair, 25 m (82 ft)	VW3E5001R250
SERCOS III cable, 2 x RJ45, shielded cable, Twisted Pair, 30 m (98.4 ft)	VW3E5001R300
SERCOS III cable, 2 x RJ45, shielded cable, Twisted Pair, 40 m (131 ft)	VW3E5001R400
SERCOS III cable, 2 x RJ45, shielded cable, Twisted Pair, 50 m (164 ft)	VW3E5001R500

Motor Cables

Description			Reference	
Shielded motor cable without holding brake	Motor end plastic connector, other cable end flying leads	4 x 0.82 mm ² (AWG 18)	1.5 m (4.92 ft)	VW3M5D1AR15
			3 m (9.84 ft)	VW3M5D1AR30
			5 m (16.4 ft)	VW3M5D1AR50
	Motor end MIL connector, other cable end flying leads	4 x 1.3 mm ² (AWG 16)	3 m (9.84 ft)	VW3M5D2AR30
			5 m (16.4 ft)	VW3M5D2AR50
		4 x 3.3 mm ² (AWG 12)	3 m (9.84 ft)	VW3M5D4AR30
			5 m (16.4 ft)	VW3M5D4AR50
		4 x 6 mm ² (AWG 10)	3 m (9.84 ft)	VW3M5D6AR30
			5 m (16.4 ft)	VW3M5D6AR50
	Shielded motor cable with holding brake	Motor end plastic connector, other cable end flying leads	6 x 0.82 mm ² (AWG 18)	3 m (9.84 ft)
5 m (16.4 ft)				VW3M5D1FR50
Motor end MIL connector, other cable end flying leads		6 x 1.3 mm ² (AWG 16)	3 m (9.84 ft)	VW3M5D2FR30
			5 m (16.4 ft)	VW3M5D2FR50
		6 x 3.3 mm ² (AWG 12)	3 m (9.84 ft)	VW3M5D4FR30
			5 m (16.4 ft)	VW3M5D4FR50
		6 x 6 mm ² (AWG 10)	3 m (9.84 ft)	VW3M5D6FR30
			5 m (16.4 ft)	VW3M5D6FR50

Encoder Cables and Accessories

Description			Reference
Encoder cable, 10 x 0.13 mm ² (AWG 26) shielded	Motor end and device end plastic connector	1.5 m (4.92 ft)	VW3M8D1AR15
		3 m (9.84 ft)	VW3M8D1AR30
		5 m (16.4 ft)	VW3M8D1AR50
	Motor end MIL connector, other cable end plastic connector	3 m (9.84 ft)	VW3M8D2AR30
		5 m (16.4 ft)	VW3M8D2AR50
Battery compartment for multi-turn encoder, cable 0.45 m (1.47 ft)			VW3M8BATC
Battery 3.6 Vdc for multi-turn encoder			VW3M9BATT

NOTE: The battery compartment and the battery are not provided with motor equipped with a multi-turn encoder and must be ordered separately.

Signal Cables

Description		Reference
Signal cable for signal interface CN1, device end 50-pin connector, other cable end flying leads	1 m (3.28 ft)	VW3M1C10R10
	2 m (6.56 ft)	VW3M1C10R20
	3 m (9.84 ft)	VW3M1C10R30

Signal Cable for Safety Function STO

Description		Reference
Signal cable for safety function STO CN9 STO cable is not allowed to be used outside the cabinet.	1 m (3.28 ft)	VW3M1C20R10
	2 m (6.56 ft)	VW3M1C20R20
	3 m (9.84 ft)	VW3M1C20R30

External Braking Resistors and Holding Brake Controller

Description				Reference
Holding brake controller HBC with automatic voltage reduction; 24 V - 1.6 A				VW3M3103
Braking resistor IP 65 connection cable 2.1 mm ² (AWG 14)	10 Ω	Maximum continuous power 400 W	0.75 m (2.46 ft)	VW3A7601R07
			2 m (6.56 ft)	VW3A7601R20
			3 m (9.84 ft)	VW3A7601R30
Braking resistor IP 65, UL connection cable 2.1 mm ² (AWG 14)	27 Ω	Maximum continuous power 100 W	0.75 m (2.46 ft)	VW3A7602R07
			2 m (6.56 ft)	VW3A7602R20
			3 m (9.84 ft)	VW3A7602R30
	Maximum continuous power 200 W	0.75 m (2.46 ft)	VW3A7603R07	
		2 m (6.56 ft)	VW3A7603R20	
		3 m (9.84 ft)	VW3A7603R30	

Description				Reference
		Maximum continuous power 400 W	0.75 m (2.46 ft)	VW3A7604R07
			2 m (6.56 ft)	VW3A7604R20
			3 m (9.84 ft)	VW3A7604R30
	72 Ω	Maximum continuous power 200 W	0.75 m (2.46 ft)	VW3A7606R07
			2 m (6.56 ft)	VW3A7606R20
			3 m (9.84 ft)	VW3A7606R30
		Maximum continuous power 400 W	0.75 m (2.46 ft)	VW3A7607R07
			2 m (6.56 ft)	VW3A7607R20
			3 m (9.84 ft)	VW3A7607R30
Braking resistor IP20, UL screw terminals M6	16 Ω	Maximum continuous power 956 W	-	VW3A7733
	10 Ω		-	VW3A7734

Circuit Breakers

Description		Reference
Circuit breaker - thermal magnetic -screw terminals	4 ... 6.3 A	GV2P10
	6 ... 10 A	GV2P14
	9 ... 14 A	GV2P16
	13 ... 18 A	GV2P20
	17 ... 23 A	GV2P21
	20 ... 25 A	GV2P22
	24 ... 32 A	GV2P32

Motor Protection Switches and Power Contactors

Drive	Nominal power	Order no. motor protection switch	Rated continuous current motor protection switch	Order no. power contactor
LXM28SUA5	50 W	GV2L10	6.3 A	LC1K0610••
LXM28SU01	100 W	GV2L10	6.3 A	LC1K0610••
LXM28SU02	200 W	GV2L14	10 A	LC1D09••
LXM28SU04	400 W	GV2L14	10 A	LC1D09••
LXM28SU07	750 W	GV2L16	14 A	LC1D12••
LXM28SU15	1500 W	GV2L22	25 A	LC1D18••
LXM28SU20	2000 W	GV2L32	30 A	LC1D32••
LXM28SU30	3000 W	GV2L32	30 A	LC1D32••

Control voltage power contactor		24 V	48 V	110 V	220 V	230 V	240 V
LC1K••••	50/60 Hz	B7	E7	F7	M7	P7	U7

Control voltage power contactor		24 V	48 V	110 V	220/230 V	230	230/240 V
LC1D••••	50 Hz	B5	E5	F5	M5	P5	U5
	60 Hz	B6	E6	F6	M6	-	U6
	50/60 Hz	B7	E7	F7	M7	P7	U7

Engineering

What's in This Part

Engineering	71
-------------------	----

Engineering

What's in This Chapter

Electromagnetic Compatibility (EMC).....	71
Cables.....	74
Residual Current Device	75
Common DC Bus	76
Safety Function STO ("Safe Torque Off").....	76
Rating the Braking Resistor.....	88
Monitoring Functions	90
Configurable Inputs and Outputs	91
Wiring.....	91

This chapter contains information on the application of the Servo Drive system for the engineering phase.

Electromagnetic Compatibility (EMC)

Electromagnetic Compatibility (EMC)

Signal interference can cause unexpected responses of the drive and of other equipment in the vicinity of the drive.

▲ WARNING
SIGNAL AND EQUIPMENT INTERFERENCE
<ul style="list-style-type: none"> • Only operate the drive with the specified external mains filter. • Install the wiring in accordance with the EMC requirements described in the present document. • Verify compliance with the EMC requirements described in the present document. • Verify compliance with all EMC regulations and requirements applicable in the country in which the product is to be operated and with all EMC regulations and requirements applicable at the installation site.
Failure to follow these instructions can result in death, serious injury, or equipment damage.

Limit Values

This product meets the EMC requirements according to the standard IEC 61800-3 if the measures described in this manual, and in particular the installation of the mains filters, are implemented during installation.

▲ WARNING
ELECTROMAGNETIC DISTURBANCES OF SIGNALS AND DEVICES
Use proper EMC shielding techniques to help prevent unintended device operation in accordance with the standard IEC 61800-3.
Failure to follow these instructions can result in death, serious injury, or equipment damage.

These types of devices are not intended to be used on a low-voltage public network which supplies domestic premises. Radio frequency interference is expected if used in such a network.

⚠ WARNING

RADIO INTERFERENCE

Do not use these products in domestic electrical networks.

Failure to follow these instructions can result in death, serious injury, or equipment damage.

As a system provider, you may have to include this information in the documentation to your customer.

Equipotential Bonding Conductors

Potential differences can result in excessive currents on the cable shields. Use equipotential bonding conductors to reduce currents on the cable shields.

⚠ WARNING

UNINTENDED EQUIPMENT OPERATION

- Ground cable shields for all fast I/O, analog I/O, and communication signals at a single point. ¹⁾
- Route communications and I/O cables separately from power cables.

Failure to follow these instructions can result in death, serious injury, or equipment damage.

¹⁾ Multipoint grounding is permissible if connections are made to an equipotential ground plane dimensioned to help avoid cable shield damage in the event of power system short-circuit currents.

The equipotential bonding conductors must be rated for the maximum current. The following conductors cross sections can be used:

- 16 mm² (AWG 4) for equipotential bonding conductors up to a length of 200 m (656 ft)
- 20 mm² (AWG 4) for equipotential bonding conductors with a length of more than 200 m (656 ft)

EMC Requirements for the Control Cabinet

EMC measures	Objective
Use mounting plates with good electrical conductivity, connect large surface areas of metal parts, remove paint from contact areas.	Good conductivity due to large surface contact.
Ground the control cabinet, the control cabinet door, and the mounting plate with ground straps or ground wires. The conductor cross section must be at least 10 mm ² (AWG 6).	Reduces emissions.
Install switching devices such as power contactors, relays, or solenoid valves with interference suppression units or arc suppressors (for example, diodes, varistors, RC circuits).	Reduces mutual interference
Do not install power components and control components adjacent to one another.	Reduces mutual interference

Additional Measures for EMC Improvement

Depending on the application, the following measures can improve the EMC-dependent values:

EMC measures	Objective
Use mains reactors.	Reduces mains harmonics, prolongs product service life.
Mount in a closed control cabinet with shielded attenuation of radiated interference	Improves the EMC limit values.

External Mains Filters

Filter/Drive Combinations

You can obtain EMC conformance by following the wiring standards and practices in the present document and installing, for each drive, the following filter/drive combination:

For further information, refer to Electromagnetic compatibility (EMC), page 71.

LXM28S	Mains filter for single-phase connection	Mains filter for three-phase connection
UA5 = 0.05 kW U01 = 0.1 kW U02 = 0.2 kW U04 = 0.4 kW U07 = 0.75 kW U10 = 1 kW	VW3A4420	VW3A4422
U15 = 1.5 kW	VW3A4421	VW3A4422
U20 = 2 kW	-	VW3A4423
U30 = 3 kW U45 = 4.5 kW	-	VW3A4424

If you use mains filters of other manufacturers, these mains filters must have the same technical data as specified mains filters.

Emission

The specified limit values are complied with if the external mains filters available as accessories are used.

The following limit values for emission are complied with if the installation is EMC-compliant and if the cables offered as accessories are used.

Lexium 28S	Category
Conducted interference	C3
Radiated emission	C3

Cables

Cables

Suitability of the Cables

Cables must not be twisted, stretched, crushed, or bent. Use only cables that comply with the cable specification. Consider the following in determining suitability of the cables:

- Suitable for drag chain applications
- Temperature range
- Chemical resistance
- Outdoor installation
- Underground installation

Equipotential Bonding Conductors

Potential differences can result in excessive currents on the cable shields. Use equipotential bonding conductors to reduce currents on the cable shields

⚠ WARNING

UNINTENDED EQUIPMENT OPERATION

- Ground cable shields for all fast I/O, analog I/O, and communication signals at a single point. ¹⁾
- Route communications and I/O cables separately from power cables.

Failure to follow these instructions can result in death, serious injury, or equipment damage.

¹⁾ Multipoint grounding is permissible if connections are made to an equipotential ground plane dimensioned to help avoid cable shield damage in the event of power system short-circuit currents.

The equipotential bonding conductor must be rated for the maximum current. The following conductor cross sections can be used:

- 16 mm² (AWG 4) for equipotential bonding conductors up to a length of 200 m (656 ft)
- 20 mm² (AWG 4) for equipotential bonding conductors with a length of more than 200 m (656 ft)

Conductor Cross Sections According to Method of Installation

The following sections describe the conductor cross sections for two methods of installation:

- Method of installation B2:
Cables in conduits or cable trunking systems
- Method of installation E:
Cables on open cable trays

Gross section in mm ² (AWG) ⁽¹⁾	Current-carrying capacity with method of installation B2 in A ⁽²⁾	Current carrying capacity with method of installation E in A ⁽²⁾
0.75 (18)	8.5	10.4
1 (16)	10.1	12.4

Cross section in mm ² (AWG) (1)	Current-carrying capacity with method of installation B2 in A(2)	Current carrying capacity with method of installation E in A(2)
1.5 (14)	13.1	16.1
2.5 (12)	17.4	22
4 (10)	23	30
6 (8)	30	37
10 (6)	40	52
16 (4)	54	70
25 (2)	70	88

(1)	See chapter "Accessories and spare parts", page 65 for available cables.
(2)	Values as per IEC 60204-1 for continuous operation, copper conductors, and ambient air temperature 40 °C (104 °F); see IEC 60204-1 for additional information.

Note the derating factors for grouping of cables and correction factors for other ambient conditions (IEC 60204-1).

The conductors must have a sufficiently large cross section so that the upstream fuse can trip.

In the case of longer cables, it may be necessary to use a greater conductor cross section to reduce the energy losses.

For conformance to UL requirements, use 75 °C (167 °F) copper conductors.

Residual Current Device

Residual Current Device

Direct current can be introduced in the protective ground conductor of this drive. If a residual current device (RCD / GFCI) or a residual current monitor (RCM) is used for protection against direct or indirect contact, the following specific types must be used:

⚠ WARNING
<p>DIRECT CURRENT CAN BE INTRODUCED INTO THE PROTECTIVE GROUND CONDUCTOR</p> <ul style="list-style-type: none"> • Use a Type A Residual Current Device (RCD / GFCI) or a Residual Current Monitor (RCM) for single-phase drives connected to a phase and to the neutral conductor. • Use a Type B Residual Current Device (RCD / GFCI) or a Residual Current Monitor (RCM) that has approval for use with frequency inverters and is sensitive to all types of current for three-phase drives and for single-phase drives not connected to a phase and the neutral conductor. <p>Failure to follow these instructions can result in death, serious injury, or equipment damage.</p>

Conditions for Use of Residual Current Device

- The drive has an increased leakage current at the moment power is applied. Use residual current devices with a response delay.
- High-frequency currents must be filtered.

Common DC Bus

Common DC Bus

Function Principle

The DC buses of several devices can be connected so that energy can be used efficiently. If one device decelerates, a different device connected to the common DC bus can use the generated braking energy. Without a common DC bus, the braking energy would be converted to heat by the braking resistor while the other device would have to be supplied with energy from mains.

Another advantage of having a common DC bus is that several devices can share one external braking resistor. The number of the individual external braking resistors can be reduced to a single braking resistor if the braking resistor is properly rated.

This and other important information can be found in the Common DC bus Application Note for the drive. If you wish to take advantage of DC bus sharing, you must first consult the Common DC bus Application Note for important safety-related information.

Requirements for Use

The requirements and limit values for parallel connection of multiple devices via the DC bus are described in the Common DC bus Application Note for the drive that can be found on www.se.com. If there are any issues or questions related to obtaining the Common DC bus Application Note, consult your local Schneider-Electric representative.

Safety Function STO (“Safe Torque Off”)

For information on using the IEC 61508 standard, refer to Functional Safety, page 78.

Process Minimizing Risks Associated with the Machine

General

The goal of designing machines safely is to protect people. The risk associated with machines with electrically controlled drives comes chiefly from moving machine parts and electricity itself.

Only you, the user, machine builder, or system integrator can be aware of all the conditions and factors realized in the design of your application for the machine. Therefore, only you can determine the automation equipment and the related safeties and interlocks which can be properly used, and validate such usage.

Hazard and Risk Analysis

Based on the system configuration and utilization, a hazard and risk analysis must be carried out for the system (for example, according to ISO 12100 or ISO 13849-1). The results of this analysis must be considered when designing the machine, and subsequently applying safety-related equipment and safety-related functions. The results of your analysis may deviate from any application examples contained in the present or related documentation. For example, additional safety components may be required. In principle, the results from the hazard and risk analysis have priority.

▲ WARNING
<p>NON-CONFORMANCE TO SAFETY FUNCTION REQUIREMENTS</p> <ul style="list-style-type: none"> Specify the requirements and/or measures to be implemented in the risk analysis you perform. Verify that your safety-related application complies to applicable safety regulations and standards. Make certain that appropriate procedures and measures (according to applicable sector standards) have been established to help avoid hazardous situations when operating the machine. Use appropriate safety interlocks where personnel and/or equipment hazards exist. Validate the overall safety-related function and thoroughly test the application. <p>Failure to follow these instructions can result in death, serious injury, or equipment damage.</p>

The ISO 13849-1 Safety of machinery - Safety-related parts of control systems - Part 1: General principle for design describes an iterative process for the selection and design of safety-related parts of controllers to reduce the risk to the machine to a reasonable degree:

To perform risk assessment and risk minimization according to ISO 12100, proceed as follows:

- Defining the boundary of the machine.
- Identifying risks associated with the machine.
- Assessing risks.
- Evaluating risks.
- Minimizing risks by:
 - Intrinsically safe design
 - Protective devices
 - User information (see ISO 12100)
- Designing safety-related controller parts (SRP/CS, Safety-Related Parts of the Control System) in an interactive process.

To design the safety-related controller parts in an interactive process, proceed as follows:

Step	Action
1	Identify necessary safety functions that are executed via SRP/CS (Safety-Related Parts of the Control System).
2	Determine required properties for each safety function.
3	Determine the required performance level PL _r .
4	Identify safety-related parts executing the safety function.
5	Determine the performance level PL of the afore-mentioned safety-related parts.

Step	Action
6	Verify the performance level PL for the safety function ($PL \geq PL_r$).
7	Verify if all requirements have been met (validation).

Additional information is available on www.se.com.

Functional Safety

Overview

Automation and safety engineering are closely related. Engineering, installation, and operation of complex automation solutions are greatly simplified by integrated safety-related functions and modules.

Usually, the safety-related engineering requirements depend on the application. The level of the requirements results from, among other things, the risk, and the hazard potential arising from the specific application and from the applicable standards and regulations.

IEC 61508 and IEC 61800-5-2

The standard IEC 61508 “Functional safety of electrical/electronic/programmable electronic safety-related systems” defines the safety-related aspects of systems. Instead of a single functional unit of a safety-related system, the standard treats all elements of a function chain as a unit. These elements must meet the requirements of the specific safety integrity level as a whole.

The standard IEC 61800-5-2 “Adjustable speed electrical power drive systems – Safety requirements – Functional” is a product standard that defines the safety-related requirements regarding drives. Among other things, this standard defines the safety functions for drives.

Safety Integrity Level (SIL)

The standard IEC 61508 defines 4 safety integrity levels (Safety Integrity Level (SIL)). Safety integrity level SIL1 is the lowest level, safety integrity level SIL4 is the highest level. The safety integrity level required for a given application is determined on the basis of the hazard potential resulting from the hazard and risk analysis. This is used to decide whether the relevant function chain is to be considered as a safety-related function chain and which hazard potential it must cover.

Average Frequency of a Dangerous Failure Per Hour (PFH)

To maintain the function of the safety-related system, the IEC 61508 standard requires various levels of measures for avoiding and controlling faults, depending on the required safety integrity level (Safety Integrity Level (SIL)). All components must be subjected to a probability assessment to evaluate the effectiveness of the measures implemented for controlling faults. This assessment determines the probability of a dangerous failure per hour PFH (Average Frequency of a Dangerous Failure per Hour (PFH)) for a safety-related system. This is the frequency per hour with which a safety-related system fails in a hazardous manner so that it can no longer perform its function correctly. Depending on the SIL, the average frequency of a dangerous failure per hour must not exceed certain values for the entire safety-related system. The individual PFH values of a function chain are added. The result must not exceed the maximum value specified in the standard.

SIL	PFH at high demand or continuous demand
4	$\geq 10^{-9} \dots < 10^{-8}$
3	$\geq 10^{-8} \dots < 10^{-7}$
2	$\geq 10^{-7} \dots < 10^{-6}$
1	$\geq 10^{-6} \dots < 10^{-5}$

Hardware Fault Tolerance (HFT) and Safe Failure Fraction (SFF)

Depending on the safety integrity level (Safety Integrity Level (SIL)) for the safety-related system, the IEC 61508 standard requires a specific hardware fault tolerance (Hardware Fault Tolerance (HFT)) in connection with a specific safe failure fraction (Safe Failure Fraction (SFF)). The hardware fault tolerance is the ability of a safety-related system to execute the required function even if one or more hardware faults are present. The safe failure fraction of a safety-related system is defined as the ratio of the rate of safe failures to the total failure rate of the safety-related system. As per IEC 61508, the maximum achievable safety integrity level of a safety-related system is partly determined by the hardware fault tolerance and the safe failure fraction of the safety-related system.

IEC 61800-5-2 distinguishes two types of subsystems (type A subsystem, type B subsystem). These types are specified on the basis of criteria which the standard defines for the safety-related components.

SFF	HFT type A subsystem			HFT type B subsystem		
	0	1	2	0	1	2
<60 %	SIL1	SIL2	SIL3	---	SIL1	SIL2
60 ... <90 %	SIL2	SIL3	SIL4	SIL1	SIL2	SIL3
90 ... <99 %	SIL3	SIL4	SIL4	SIL2	SIL3	SIL4
≥ 99 %	SIL3	SIL4	SIL4	SIL3	SIL4	SIL4

Fault Avoidance Measures

Systematic errors in the specifications, in the hardware and the software, incorrect usage and maintenance of the safety-related system must be avoided to the maximum degree possible. To meet these requirements, IEC 61508 specifies a number of measures for fault avoidance that must be implemented depending on the required safety integrity level (Safety Integrity Level (SIL)). These measures for fault avoidance must cover the entire life cycle of the safety-related system, i.e. from design to decommissioning of the system.

Data for Maintenance Plan and the Calculations for the Safety Function

The safety function must be tested at regular intervals. The interval depends on the hazard and risk analysis of the total system. The minimum interval is 1 year (high demand mode as per IEC 61508).

Use the following data of the safety function STO for your maintenance plan and the calculations for the safety function:

Description	Unit	Value
Lifetime of the safety function STO (IEC 61508) ⁽¹⁾	Years	20
SFF (IEC 61508) Safe Failure Fraction	%	98.9
Safety integrity level	–	SIL CL 2

Description	Unit	Value
IEC 61508 IEC 62061 IEC 61800-5-2		
PFH (IEC 61508) Probability of Dangerous Hardware Failure per Hour	1/h	STO_A ⁽²⁾ : 1.7×10^{-9} STO_B ⁽³⁾ : 1.5×10^{-9}
PFD _{avg} (IEC 61508) Probability of Failure on Demand, calculated as one demand per year	–	STO_A ⁽²⁾ : 1.5×10^{-4} STO_B ⁽³⁾ : 1.3×10^{-4}
PL (ISO 13849-1) Performance Level	–	d (category 3)
MTTF _d (ISO 13849-1) Mean Time to Dangerous Failure	Years	STO_A ⁽²⁾ : 66757 STO_B ⁽³⁾ : 78457
(1)	See chapter Lifetime Safety Function STO, page 263	
(2)	STO_A: LXM28SUA5, LXM28SU01, LXM28SU02, LXM28SU04, LXM28SU07, LXM28SU10, LXM28SU15, LXM28SU20	
(3)	STO_B: LXM28SU30, LXM28SU45	

If two non-adjacent IGBTs have a short circuit, a movement of a maximum of 120 degrees (electrical) can occur even if the safety function STO is active. Include in your risk analysis the probability of IGBT short circuits, and make a determination whether it is acceptable as it relates to your application.

⚠ WARNING

UNINTENTIONAL MOVEMENT DURING STO FUNCTION

Use appropriate safety interlocks (such as a service brake) where personnel and/or equipment hazards exist.

Failure to follow these instructions can result in death, serious injury, or equipment damage.

The probability of such a condition is 1.5×10^{-15} per hour (without common cause error). Include this in your calculations for the safety function.

The probability of such a condition is highly unlikely but possible. An unexpected movement has to be considered and ruled out. A fault exclusion is required such that it is not possible to short circuit the STO by another voltage carrying line.

Contact your local sales office for additional information, if required.

Definitions

Integrated Safety-Related Function "Safe Torque Off" STO

The integrated safety-related function STO (IEC 61800-5-2) allows for a category 0 stop as per IEC 60204-1 without external power contactors. It is not necessary to interrupt the supply voltage for a category 0 stop. This reduces the system costs and the response times.

Category 0 Stop (IEC 60204-1)

In stop category 0 (Safe Torque Off, STO), the drive coasts to a stop (provided there are no external forces operating to the contrary). The safety-related function STO is intended to help prevent an unintended start-up, not stop a motor, and therefore corresponds to an unassisted stop in accordance with IEC 60204-1.

In circumstances where external influences are present, the coast down time depends on physical properties of the components used (such as weight, torque, friction, etc.), and additional measures such as external safety-related brakes may be necessary to help prevent any hazard from materializing. That is to say, if this means a hazard to your personnel or equipment, you must take appropriate measures.

▲ WARNING

UNINTENDED EQUIPMENT OPERATION

- Make certain that no hazards can arise for persons or material during the coast down period of the axis/machine.
- Do not enter the zone of operation during the coast down period.
- Ensure that no other persons can access the zone of operation during the coast down period.
- Use appropriate safety interlocks where personnel and/or equipment hazards exist.

Failure to follow these instructions can result in death, serious injury, or equipment damage.

Category 1 Stop (IEC 60204-1)

For stops of category 1 (Safe Stop 1, SS1), you can initiate a controlled stop via the control system, or through the use of specific functional safety-related devices. A Category 1 Stop is a controlled stop with power available to the machine actuators to achieve the stop.

The controlled stop by the control/safety-related system is not safety-relevant, nor monitored, and does not perform as defined in the case of a power outage or if an error is detected. This has to be implemented by means of an external safety-related switching device with safety-related delay.

Function

The safety function STO integrated into the product can be used to implement an “EMERGENCY STOP” (IEC 60204-1) for category 0 stops. With an additional, approved EMERGENCY STOP safety relay module, it is also possible to implement category 1 stops.

The safety function STO switches the supply voltage of the IGBT drivers so that PWM signals cannot switch the IGBTs. The following diagram illustrates the concept:

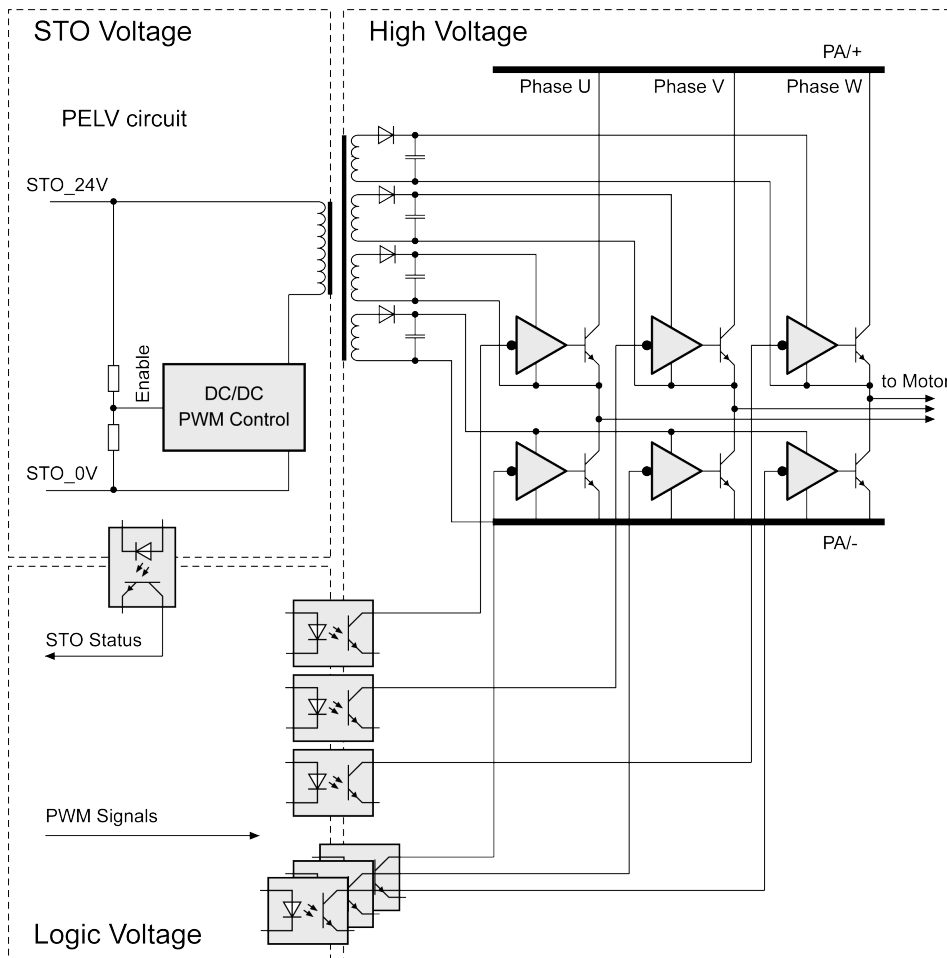

Requirements for Using the Safety Function

The safety function STO (Safe Torque Off) does not remove power from the DC bus. The safety function STO only removes power to the motor. The DC bus voltage and the mains voltage to the drive are still present.

⚡ ⚠ DANGER

ELECTRIC SHOCK

- Do not use the safety function STO for any other purposes than its intended function.
- Use an appropriate switch, that is not part of the circuit of the safety function STO, to disconnect the drive from the mains power.

Failure to follow these instructions will result in death or serious injury.

After the safety function STO is triggered, the motor can no longer generate torque and coasts down without braking in the case of motors without a holding brake. In the case of motors with holding brake, the holding brake is not a safety-related function, and may not be sufficient to hold the axis at a standstill.

▲ WARNING**UNINTENDED EQUIPMENT OPERATION**

Install a dedicated service brake if coasting does not meet the deceleration requirements of your application.

Failure to follow these instructions can result in death, serious injury, or equipment damage.

The safety function STO is factory-deactivated by means of the jumper for CN9. If you want to use the safety function STO, you must remove the jumper for CN9. You may only use the safety function STO with an external PELV 24 Vdc power supply unit.

▲ WARNING**UNINTENDED EQUIPMENT OPERATION**

- Remove the jumpers connected to the STO power connector (CN9) only if you intend to use the STO safety-related function for your application.
- Use only an external PELV 24 Vdc power supply unit when applying the safety-related STO function.

Failure to follow these instructions can result in death, serious injury, or equipment damage.

For additional information on deactivating the safety function STO, refer to Connection STO (CN9), page 121.

Holding Brake and Safety Function STO

When the safety function STO is triggered, the power stage is immediately disabled. In the case of vertical axes or external forces acting on the load, you may have to take additional measures to bring the load to a standstill and to keep it at a standstill when the safety function STO is used, for example, by using a service brake.

▲ WARNING**FALLING LOAD**

Ensure that all loads come to a secure standstill when the safety function STO is used.

Failure to follow these instructions can result in death, serious injury, or equipment damage.

If the suspension of hanging / pulling loads is a safety objective for the machine, then you can only achieve this objective by using an appropriate external brake as a safety-related measure.

▲ WARNING**UNINTENDED AXIS MOVEMENT**

- Do not use the internal holding brake as a safety-related measure.
- Only use certified external brakes as safety-related measures.

Failure to follow these instructions can result in death, serious injury, or equipment damage.

NOTE: The drive does not provide its own safety-related output to connect an external brake to use as a safety-related measure.

Unintended Restart

To help avoid unintended restart of the motor after restoration of power (for example, after power outage), the parameter P2-68 must be set to "X=0". A controlled restart must be managed externally from the drive, note that the external management itself must not trigger an unintended restart.

▲ WARNING

UNINTENDED EQUIPMENT OPERATION

Set parameter P2-68 setting X to 0 (zero) if the automatic enabling of the power stage presents hazards in your application.

Failure to follow these instructions can result in death, serious injury, or equipment damage.

Degree of Protection When the Safety Function Is Used

You must ensure that conductive substances cannot get into the product (pollution degree 2). Conductive substances may cause the safety function to become inoperative.

▲ WARNING

INOPERABLE SAFETY FUNCTION

Ensure that conductive substances (water, contaminated or impregnated oils, metal shavings, etc.) cannot get into the drive.

Failure to follow these instructions can result in death, serious injury, or equipment damage.

Protected Cable Installation

If short circuits or other wiring errors such as a cross fault between STO inputs can be expected in connection with safety-related signals, and if these short circuits or other wiring errors are not detected by upstream devices, protected cable installation as per ISO 13849-2 is required.

ISO 13849-2 describes protected cable installation for cables for safety-related signals. The cables for the safety function STO must be protected against external voltage. A shield with ground connection helps to keep external voltage away from the cables for the signals of the safety function STO.

- Use shielded cables for the signals of the safety function STO.
- Do not use the cable for the signals of the safety function STO for other signals.
- Connect one end of the shield.
- When daisy chaining the signals of the safety function STO, connect the shield to the equipotential grounding plane associated to the drives.

Hazard and Risk Analysis

You must conduct, or ensure that your OEM, system integrator, or anyone responsible for the development of the application containing the equipment indicated in the present document conducts a hazard and risk analysis of the entire system. The results of the analysis must be taken into account in the application of the safety function.

The type of circuit resulting from the analysis may differ from any application examples provided in the present document or any supplementary documents

concerning this equipment. Additional safety components may be required. The results of the hazard and risk analysis have priority over any other design considerations. Pay particular attention in conforming to any safety information, different electrical requirements, and normative standards that would apply to your system.

⚠ WARNING
UNINTENDED EQUIPMENT OPERATION
<ul style="list-style-type: none"> • Perform a hazard and risk analysis to determine the appropriate safety integrity level, and any other safety requirements, for your specific application based on all the applicable standards. • Ensure that the hazard and risk analysis is conducted and respected according to EN/ISO 12100 during the design of your machine.
Failure to follow these instructions can result in death, serious injury, or equipment damage.

Application Examples STO

Example of Category 0 Stop

Use without EMERGENCY STOP safety relay module, category 0 stop.

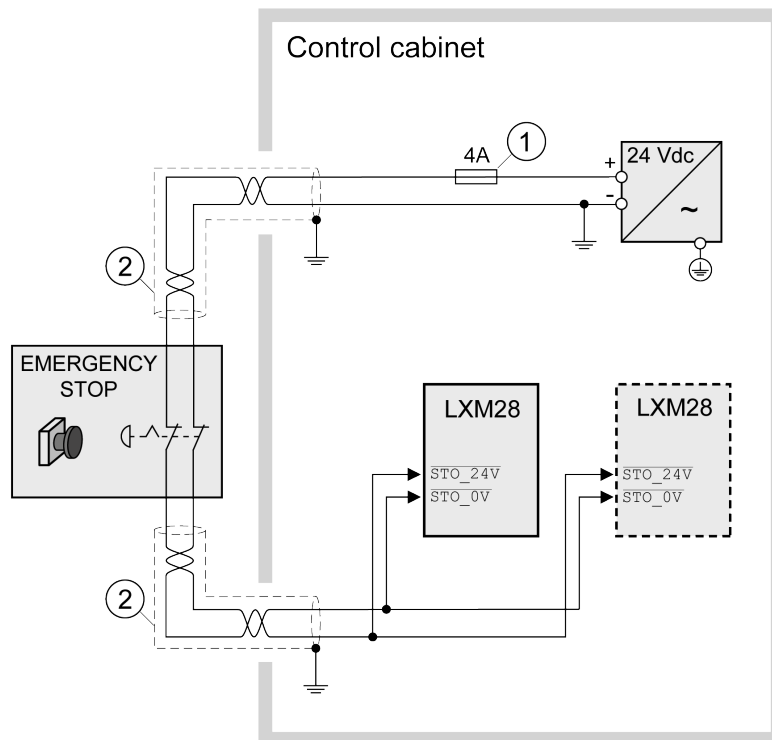

1 If the maximum output current of the 24 V power supply exceeds 4 A, a 4 A slow-blow fuse is required.

2 Grounded shielded cable for wiring out of the control cabinet.

A fault exclusion is required such that it is not possible to short circuit the STO by another voltage carrying line. For the STO Cables defined by EN 61800-5-2:2007 Table D.1 or EN 61800-5-2:2017 with reference to ISO 13849-1 Table D.4.: For the required fault exclusion the cables must be permanently connected (fixed) and protected against external damage, for example by cable ducting or armored cables (steel jacket or ridged shielding).

For further information on STO wiring, refer to [Connection of STO \(CN9\)](#), page 121

NOTE: The internal DC power supply of the drive is only to be used to deactivate the safety function STO via the jumper supplied with the drive.

⚠ WARNING

UNINTENDED EQUIPMENT OPERATION

- Remove the jumpers connected to the STO power connector (CN9) only if you intend to use the STO safety-related function for your application.
- Use only an external PELV 24 Vdc power supply unit when applying the safety-related STO function.

Failure to follow these instructions can result in death, serious injury, or equipment damage.

In this example, when an EMERGENCY STOP is activated, it leads to a category 0 stop:

The power stage is immediately disabled via the inputs STO_24V and STO_0V of the safety function STO. Power can no longer be supplied to the motor. If the motor is not already at a standstill when the STO is triggered, it decelerates under the salient physical forces (gravity, friction, etc.) active at the time until presumably coasting to a standstill.

⚠ WARNING

UNINTENDED EQUIPMENT OPERATION

Install a dedicated service brake if coasting does not meet the deceleration requirements of your application.

Failure to follow these instructions can result in death, serious injury, or equipment damage.

If the coasting of the motor and its potential load is unsatisfactory as determined by your risk and hazard analysis, an external service brake may also be required. Refer to Holding Brake and Safety Function STO, page 83.

Example of Category 1 Stop

Use with EMERGENCY STOP safety relay module, category 1 stop. Example of category 1 stop with external Preventa XPS-AV EMERGENCY STOP safety relay module.

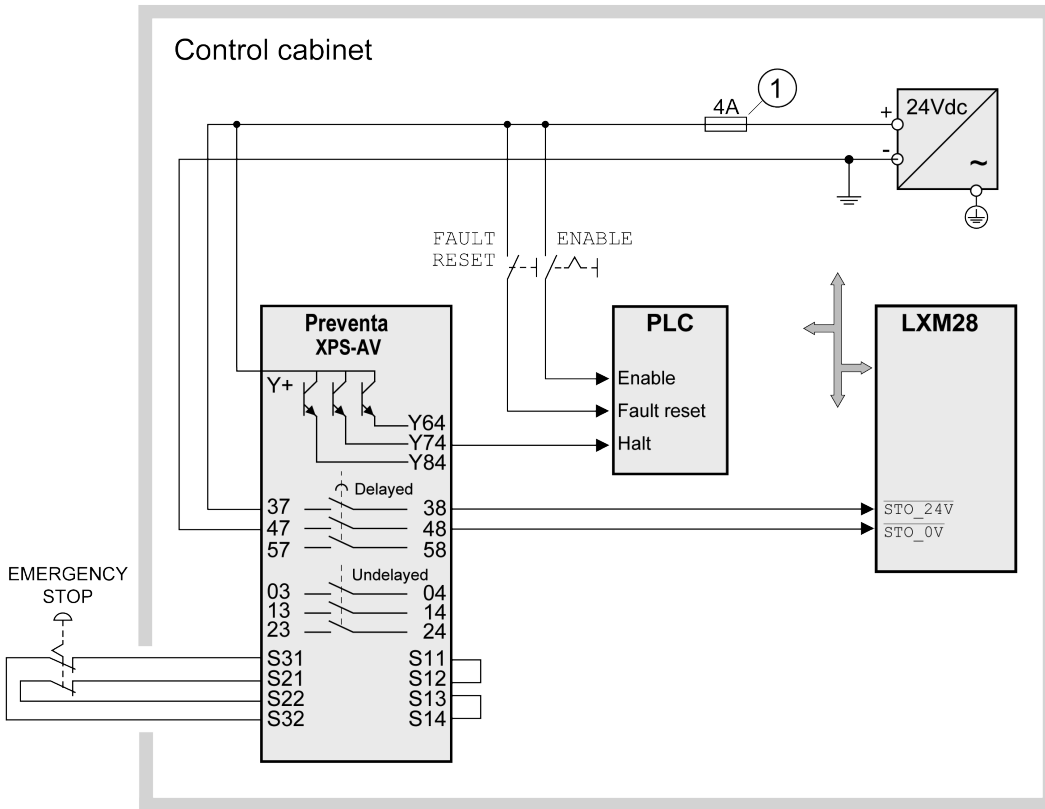

1 If the maximum output current of the 24 V power supply exceeds 4 A, a 4 A slow-blow fuse is required.

For more information on STO wiring, see chapter Connection of STO (CN9), page 121

In this example, when an EMERGENCY STOP is activated, it leads to a category 1 stop:

- The safety relay module requests an immediate stop (undelayed) of the drive via the logic controller (Halt). The logic controller takes the configured or programmed action to instruct the drive to make a decelerated stop.
- The power stage is disabled via the inputs STO_24V and STO_0V of the safety function STO after the delay time set in the EMERGENCY STOP safety relay module has elapsed. Power can no longer be supplied to the motor. If the motor is not already at a standstill when safety function STO is triggered when the delay time has elapsed, it decelerates under the salient physical forces (gravity, friction, etc.) active at the time until presumably coasting to a standstill.

If the coasting of the motor and its potential load is unsatisfactory as determined by your risk and hazard analysis, an external service brake may also be required. Refer to Holding Brake and Safety Function STO, page 83.

⚠ WARNING

UNINTENDED EQUIPMENT OPERATION

Install a dedicated service brake if coasting does not meet the deceleration requirements of your application.

Failure to follow these instructions can result in death, serious injury, or equipment damage.

NOTE: The specified minimum current and the permissible maximum current of the relay outputs of the EMERGENCY STOP safety relay module must be respected.

Rating the Braking Resistor

Rating the Braking Resistor

Braking resistors are required for dynamic applications. During deceleration, the kinetic energy is transformed into electrical energy in the motor. The electrical energy increases the DC bus voltage. The braking resistor is activated when the defined threshold value is exceeded. The braking resistor transforms electrical energy into heat. If highly dynamic deceleration is required, the braking resistor must be well adapted to the system. External driving forces acting on the motor can cause high currents to be regenerated and supplied back to the drive.

⚠ DANGER

FIRE DUE TO EXTERNAL DRIVING FORCES ACTING ON MOTOR

Verify that no external forces can act on the motor that will exceed the capacity of the braking resistor.

Failure to follow these instructions will result in death or serious injury.

An insufficiently rated braking resistor can cause overvoltage on the DC bus. Overvoltage on the DC bus causes the power stage to be disabled. The motor is no longer actively decelerated.

⚠ WARNING

UNINTENDED EQUIPMENT OPERATION

- Verify that the braking resistor has a sufficient rating by performing a test run under maximum load conditions.
- Verify that the parameter settings for the braking resistor are correct.

Failure to follow these instructions can result in death, serious injury, or equipment damage.

If multiple drives are connected via a common DC bus, this affects all motors. For further information, refer to [Common DC bus](#), page 76.

An [external braking resistor](#), page 68 is required for applications in which the motor must be decelerated quickly and the internal braking resistor cannot absorb the excess braking energy.

Internal Braking Resistor

Introduction

The drive has an internal braking resistor. If the internal braking resistor is insufficient for the dynamics of the application, one or more external braking resistors must be used.

The resistance values for external braking resistors must not be below the specified minimum resistance. If an external braking resistor is activated by using the appropriate parameter, the internal braking resistor is deactivated.

LXM28S***M3X	Unit	UA5, U01, U02, U04	U07	U10, U15	U20	U30, U45
Resistance value of internal braking resistor	Ω	100	40		22	
Continuous power internal braking resistor P _{PR}	W	60	60		100	
Peak energy E _{CR} ⁽¹⁾	Ws	152	380		691	
External braking resistor minimum	Ω	25		15	8	
External braking resistor maximum ⁽²⁾	Ω	50			25	
Maximum continuous power external braking resistor	W	640		1000	1500	2500
Switch-on voltage braking resistor	V	390				
Capacitance of the internal capacitors	μF	820		1640	2110	3280
Energy absorption of internal capacitors E _{var} at nominal voltage 230 V +10%	Ws	8.87		17.76	22.82	35.51
(1)	Parameter P1-71 is set to 100 ms.					
(2)	The maximum specified braking resistor can derate the peak power of the device. Depending on the application, it is possible to use a greater ohm resistor.					

External Braking Resistors

Introduction

An external braking resistor is required for applications in which the motor must be decelerated quickly and the internal braking resistor cannot absorb the excess braking energy. The temperature of the braking resistor may exceed 250 °C (482 ° F) during operation.

▲ WARNING
HOT SURFACES
<ul style="list-style-type: none"> • Ensure that it is not possible to make any contact with a hot braking resistor. • Do not allow flammable or heat-sensitive parts in the immediate vicinity of the braking resistor. • Verify that the heat dissipation is sufficient by performing a test run under maximum load conditions.
Failure to follow these instructions can result in death, serious injury, or equipment damage.

VW3A760•	Unit	1R•• ⁽¹⁾	2R••	3R••	4R•• ⁽¹⁾	5R••	6R••	7R•• ⁽¹⁾
Resistance	Ω	10	27			72		
Continuous power	W	400	100	200	400	100	200	400
Maximum time in braking at 115 V / 230 V	s	0.72	0.552	1.08	2.64	1.44	3.72	9.6
Peak power at 115 V / 230 V	kW	18.5	6.8			2.6		
Maximum peak energy at 115 V / 230 V	Ws	13300	3800	7400	18100	3700	9600	24700

VW3A760•	Unit	1R•• (1)	2R••	3R••	4R•• (1)	5R••	6R••	7R•• (1)
Degree of protection	-	IP 65						
(1)	Resistors with a continuous power of 400 W are not UL/CSA-approved.							

VW3A77•	Unit	04	05
Resistance	Ω	15	10
Continuous power	W	1000	
Maximum time in braking at 115 V / 230 V	s	3.5	1.98
Peak power at 115 V / 230 V	kW	12.3	18.5
Maximum peak energy at 115 V / 230 V	Ws	43100	36500
Degree of protection	-	IP20	

Monitoring Functions

Monitoring Functions

Overview

The monitoring functions of the drive can be used to monitor movements and to monitor internal signals. These monitoring functions are not safety-related functions.

The following monitoring functions are available:

Monitoring function	Task
Data connection	Monitors data connection for interruption
Limit switch signals	Monitors for permissible movement range
Position deviation	Monitors for difference between actual position and reference position
Motor overload	Monitors for excessively high current in the motor phases
Overvoltage and undervoltage	Monitors for overvoltage and undervoltage of the power stage supply and the DC bus
Overtemperature	Monitors the drive for overtemperature
Encoder overtemperature	Monitors the encoder for overtemperature
Overvoltage and undervoltage	Monitors the logic supply and power stage supply for permissible voltage range
Overvoltage at digital inputs	Monitors the digital inputs for overvoltage
Power supply encoder	Monitors the encoder supply for short circuit and permissible voltage range
Current limitation (Foldback)	Power limitation in the case of overloads for the motor, the output current, the output power, and the braking resistor.

Configurable Inputs and Outputs

Configurable Inputs and Outputs

Presentation

This drive has digital inputs and outputs that can be configured. The inputs and outputs have a defined default assignment depending on the operating mode. This assignment can be adapted to the requirements of the customer's installation.

For further details, refer to chapter Operation, page 223.

Wiring

General Wiring

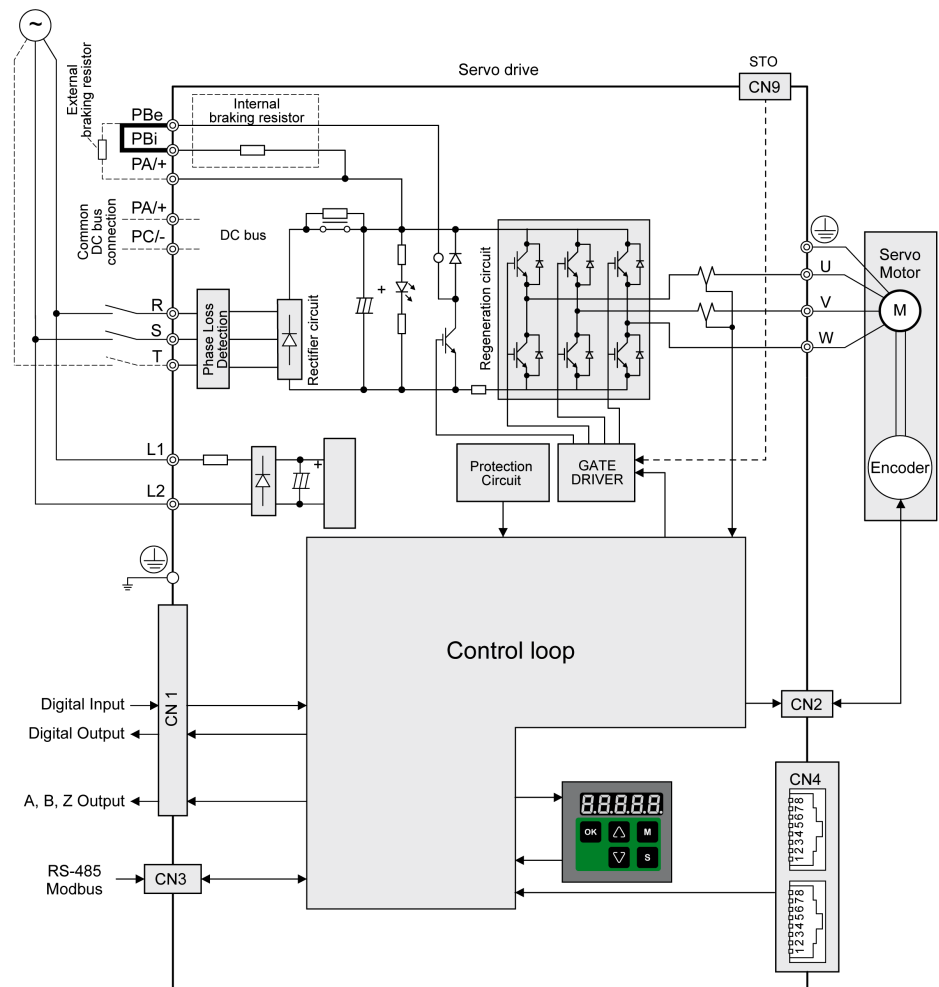

Installation

What's in This Part

Before Mounting.....	94
Drive Installation	95
Motor Installation.....	124
Verifying Installation	133

Introduction

An engineering phase is mandatory prior to mechanical and electrical installation. For basic information, refer to Engineering, page 71.

DANGER

INSUFFICIENT GROUNDING

- Use a protective ground conductor with at least 10 mm² (AWG 6) or two protective ground conductors with the cross section of the conductors supplying the power terminals.
- Verify compliance with all local and national electrical code requirements as well as all other applicable regulations with respect to grounding of the entire drive system.
- Ground the drive system before applying voltage.
- Do not use conduits as protective ground conductors; use a protective ground conductor inside the conduit.
- Do not use cable shields as protective ground conductors.
- Keep foreign objects from getting into the product.
- Verify the correct seating of seals and cable entries in order to avoid contamination such as deposits and humidity.

Failure to follow these instructions will result in death or serious injury.

In the case of a ground error, the maximum permissible current in the motor phases may be exceeded.

DANGER

FIRE CAUSED BY INCORRECT INSTALLATION

Use upstream, external ground error detection equipment (Residual Current Device / Ground Fault Circuit Interrupter).

Failure to follow these instructions will result in death or serious injury.

▲ WARNING

LOSS OF CONTROL

- The designer of any control scheme must consider the potential failure modes of control paths and, for certain critical control functions, provide a means to achieve a safe state during and after a path failure. Examples of critical control functions are emergency stop and overtravel stop, power outage and restart.
- Separate or redundant control paths must be provided for critical control functions.
- System control paths may include communication links. Consideration must be given to the implications of unanticipated transmission delays or failures of the link.
- Observe all accident prevention regulations and local safety guidelines.¹
- Each implementation of this equipment must be individually and thoroughly tested for proper operation before being placed into service.

Failure to follow these instructions can result in death, serious injury, or equipment damage.

¹ For additional information, refer to NEMA ICS 1.1 (latest edition), "Safety Guidelines for the Application, Installation, and Maintenance of Solid State Control" and to NEMA ICS 7.1 (latest edition), "Safety Standards for Construction and Guide for Selection, Installation and Operation of Adjustable-Speed Drive Systems" or their equivalent governing your particular location.

Conductive foreign objects, dust or liquids may cause safety functions to become inoperative.

▲ WARNING

LOSS OF SAFETY FUNCTION CAUSED BY FOREIGN OBJECTS

Protect the system against contamination by conductive substances.

Failure to follow these instructions can result in death, serious injury, or equipment damage.

The metal surfaces of the product may exceed 65 °C (149 °F) (for bare metal) during operation.

▲ WARNING

HOT SURFACES

- Avoid unprotected contact with hot surfaces.
- Do not allow flammable or heat-sensitive parts in the immediate vicinity of hot surfaces.
- Verify that the heat dissipation is sufficient by performing a test run under maximum load conditions.

Failure to follow these instructions can result in death, serious injury, or equipment damage.

▲ CAUTION

INOPERABLE EQUIPMENT DUE TO INCORRECT MAINS VOLTAGE CONNECTION

- Verify that you use the correct mains voltage; install a transformer, if necessary.
- Do not connect mains voltage to the output terminals (U, V, W).

Failure to follow these instructions can result in injury or equipment damage.

Before Mounting

What's in This Chapter

Inspecting the Product	94
Scope of Supply	94

Inspecting the Product

Inspecting the Product

- Verify the product version by means of the type code on the nameplate. Refer to chapter Nameplate and chapter Type Code, page 28.
- Prior to mounting, inspect the product for visible damage.

Damaged products may cause electric shock or unintended equipment operation.

DANGER

ELECTRIC SHOCK OR UNINTENDED EQUIPMENT OPERATION

- Do not use damaged products.
- Keep foreign objects (such as chips, screws or wire clippings) from getting into the product.

Failure to follow these instructions will result in death or serious injury.

Contact your local Schneider Electric representative if you detect any damage whatsoever to the products.

Scope of Supply

Drive

- Drive Lexium 28S
- Connector kit with 3 connectors for:
 - Power stage supply and logic supply
 - Braking resistor
Including jumper between **PBi** and **PBe**
 - Motor
- Plastic tool for opening the spring terminals (available for devices from 50 W to 1.5 kW)
- 4-pin connector for deactivating the safety function STO (CN9)
- Adhesive hazard labels in 5 languages (German, French, Italian, Spanish, Chinese)
- Instruction sheet for the product

Motor

- BCH2 servo motor
- BCH2•R: 2 eyebolts
- Information sheet for the product

Drive Installation

What's in This Chapter

Mechanical Installation Drive	95
Electrical Installation Drive	98
Connection Grounding Screw.....	99
Connection I/O Interface (CN1)	100
Connecting the Motor Encoder (CN2)	107
Connection PC (CN3).....	109
Connection Fieldbus (CN4).....	110
Connection Logic Supply and Power Stage Supply (CN5)	112
Connection DC Bus (CN6)	114
Connection Braking Resistor (CN7)	115
Connecting the Motor Phases (CN8).....	117
Holding Brake Connection	120
Connection STO (CN9).....	121

Mechanical Installation Drive

⚠️ DANGER
ELECTRIC SHOCK OR UNINTENDED EQUIPMENT OPERATION
<ul style="list-style-type: none"> • Keep foreign objects from getting into the product. • Verify the correct seating of seals and cable entries in order to avoid contamination such as deposits and humidity.
Failure to follow these instructions will result in death or serious injury.

Conductive foreign objects, dust or liquids may cause safety functions to become inoperative.

⚠️ WARNING
LOSS OF SAFETY FUNCTION CAUSED BY FOREIGN OBJECTS
Protect the system against contamination by conductive substances.
Failure to follow these instructions can result in death, serious injury, or equipment damage.

The metal surfaces of the product may exceed 70 °C (158 °F) during operation.

⚠️ WARNING
HOT SURFACES
<ul style="list-style-type: none"> • Avoid unprotected contact with hot surfaces. • Do not allow flammable or heat-sensitive parts in the immediate vicinity of hot surfaces. • Verify that the heat dissipation is sufficient by performing a test run under maximum load conditions.
Failure to follow these instructions can result in death, serious injury, or equipment damage.

Attaching a Hazard Label with Safety Instructions

Included in the packaging of the drive are adhesive hazard labels in German, French, Italian, Spanish, and Chinese languages. The English version is affixed to

the drive by the factory. If the country to which your final machine or process is to be delivered is other than English speaking:

- Select the hazard label suitable for the target country.
Respect the safety regulations in the target country.
- Attach the hazard label to the front of the device so that it is clearly visible.

Control Cabinet

The control cabinet (enclosure) must have a sufficient size so that all devices and components can be permanently installed and wired in compliance with the EMC requirements.

The ventilation of the control cabinet must be sufficient to comply with the specified ambient conditions for the devices and components operated in the control cabinet.

Install and operate this equipment in a control cabinet rated for its intended environment and secured by a keyed or tooled locking mechanism.

Mounting Distances, Ventilation

When selecting the position of the device in the control cabinet, note the following:

- Mount the device in a vertical position ($\pm 10^\circ$). This is required for cooling the device.
- Adhere to the minimum installation distances for required cooling. Avoid heat accumulations.
- Do not mount the device close to heat sources.
- Do not mount the device on or near flammable materials.
- The heated airflow from other devices and components must not heat up the air used for cooling the device.

The connection cables of the devices are routed to the top and to the bottom. The minimum distances must be adhered to for air circulation and cable installation.

Mounting distances and air circulation

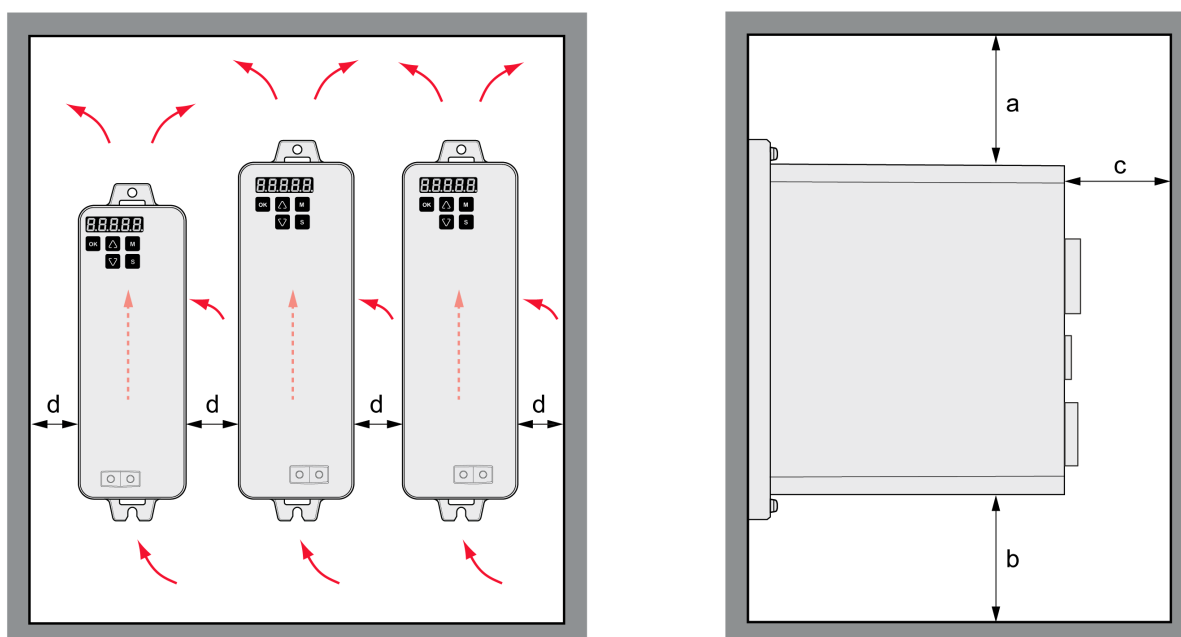

LXM28SUA5, U01, U02, U04, U07, U10, U15, U20, U30, U45

Distance	Unit	Value		
Free space a above the device	mm (in)	≥50 (≥1.97)		
Free space b below the device	mm (in)	≥50 (≥1.97)		
Free space c in front of the device ⁽¹⁾	mm (in)	≥60 (≥2.36)		
Free space d between devices	mm (in)	≥15 (≥0.59)		
<table border="1"> <tr> <td>(1)</td> <td>The free space is strictly for observing proper ventilation and may not be sufficient for your wiring requirements.</td> </tr> </table>			(1)	The free space is strictly for observing proper ventilation and may not be sufficient for your wiring requirements.
(1)	The free space is strictly for observing proper ventilation and may not be sufficient for your wiring requirements.			

Mounting the Drive

For further information on the dimensions of the mounting holes, refer to chapter Dimensions, page 30.

Painted surfaces may create electrical resistance or isolation. Before mounting the device to a painted mounting plate, remove all paint across a large area of the mounting points.

- Respect the ambient conditions in chapter Environmental Conditions, page 28.
- Mount the device in a vertical position ($\pm 10^\circ$).
- Device is suitable for mounting on concrete or other non-combustible surfaces only.
- This open type CDM does not provide comprehensive mitigation for fire hazards.

It is intended to be installed inside a supplementary enclosure or in a restricted-access area which provides appropriate protection against spread of fire.

- This open type BDM/CDM does not provide protection against direct contact to hazardous live parts.

It is intended to be installed inside a supplementary enclosure or in a restricted-access area which provides appropriate protection against electric shock.

Electrical Installation Drive

Introduction

DANGER

INSUFFICIENT GROUNDING

- Use a protective ground conductor with at least 10 mm² (AWG 6) or two protective ground conductors with the cross section of the conductors supplying the power terminals.
- Verify compliance with all local and national electrical code requirements as well as all other applicable regulations with respect to grounding of the entire drive system.
- Ground the drive system before applying voltage.
- Do not use conduits as protective ground conductors; use a protective ground conductor inside the conduit.
- Do not use cable shields as protective ground conductors.
- Keep foreign objects from getting into the product.
- Verify the correct seating of seals and cable entries in order to avoid contamination such as deposits and humidity.

Failure to follow these instructions will result in death or serious injury.

Direct current can be introduced in the protective ground conductor of this drive. If a residual current device (RCD / GFCI) or a residual current monitor (RCM) is used for protection against direct or indirect contact, the following specific types must be used:

WARNING

DIRECT CURRENT CAN BE INTRODUCED INTO THE PROTECTIVE GROUND CONDUCTOR

- Open type BDM/CDM and sub-assemblies do not use protective measures for basic protection. The protection shall be provided in the installation.
- Use a Type A Residual Current Device (RCD / GFCI) or a Residual Current Monitor (RCM) for single-phase drives connected to a phase and to the neutral conductor.
- Use a Type B Residual Current Device (RCD / GFCI) or a Residual Current Monitor (RCM) that has approval for use with frequency inverters and is sensitive to all types of current for three-phase drives and for single-phase drives not connected to a phase and the neutral conductor.

Failure to follow these instructions can result in death, serious injury, or equipment damage.

The entire installation procedure must be performed without voltage present.

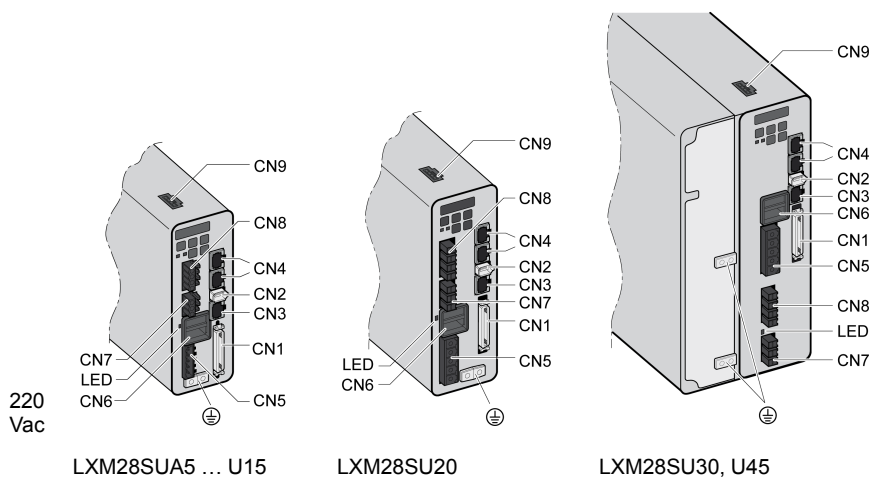

Item	Description	Refer to
CN1	Signal interface For connecting master controller or I/O signals.	Connection I/O Interface (CN1), page 100
CN2	Connection for motor encoder	Connecting the Motor Encoder (CN2), page 107
CN3	Modbus (commissioning interface) For connecting PC via converter TCSMCNAM3M002P	Connection PC (CN3), page 109
CN4	2 connections for fieldbus SERCOS III For connecting master controller.	Connection Fieldbus (CN4), page 110
CN5	Power stage supply (R,S,T) and logic supply (L1, L2)	Connection Logic Supply and Power Stage Supply (CN5), page 112
CN6	DC bus connection	Connection DC bus (CN6), page 114
LED	DC bus LED The LED is illuminated when mains voltage or internal charge are present. The DC bus LED is not an indicator of the absence of DC bus voltage.	-
CN7	Connection for external braking resistor	Connection braking resistor (CN7), page 115
CN8	Motor phases connection (U, V, W, PE)	Connecting the motor phases (CN8), page 117
CN9	Connection for safety function STO	Connection STO (CN9), page 121

Connection Grounding Screw

This product has a leakage (touch) current greater than 3.5 mA. If the protective ground connection is interrupted, a hazardous leakage (touch) current may flow if the housing is touched.

⚡⚠ DANGER

INSUFFICIENT GROUNDING

- Use a protective ground conductor with at least 10 mm² (AWG 6) or two protective ground conductors with the cross section of the conductors supplying the power terminals.
- Verify compliance with all local and national electrical code requirements as well as all other applicable regulations with respect to grounding of the entire drive system.
- Ground the drive system before applying voltage.
- Do not use conduits as protective ground conductors; use a protective ground conductor inside the conduit.
- Do not use cable shields as protective ground conductors.
- Keep foreign objects from getting into the product.
- Verify the correct seating of seals and cable entries in order to avoid contamination such as deposits and humidity.

Failure to follow these instructions will result in death or serious injury.

The central grounding screws of the product are located at the front side.

LXM28SUA5...U15

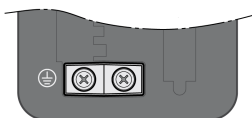

LXM28SU20

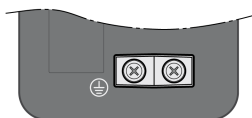

LXM28SU30, U45

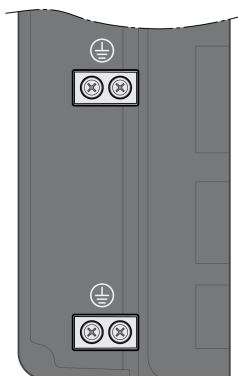

- Use ring-type cable lugs or fork-type cable lugs.
- Connect the ground connection of the device to the equipotential ground plane of your system.

LXM28S	Unit	UA5, U01, U02, U04, U07, U10, U15, U20, U30, U45
Tightening torque of grounding screw	Nm (lb.in)	1.3 (11.5)
Screw type	-	M4 x 8 socket button head screw

Connection I/O Interface (CN1)

The I/O Interface (CN1) is a Sub-D 50-pin female connector. The following table describes the contacts of the connector:

Pin	Signal	Meaning	Pin	Signal	Meaning
1	DO4+	Digital output 4	2	DO3-	Digital output 3
3	DO3+	Digital output 3	4	DO2-	Digital output 2
5	DO2+	Digital output 2	6	DO1-	Digital output 1

Pin	Signal	Meaning	Pin	Signal	Meaning
7	DO1+	Digital output 1	8	DI4-	Digital input 4
9	DI1-	Digital input 1	10	DI2-	Digital input 2
11	COM+	Reference potential to DI1... DI8	12	-	Reserved
13	-	Reserved	14	-	Reserved
15	-	Reserved	16	-	Reserved
17	VDD	24 Vdc power supply (for external I/O)	18	-	Reserved
19	-	Reserved	20	-	Reserved
21	OA	ESIM channel A	22	/OA	ESIM channel A, inverted
23	/OB	ESIM channel B, inverted	24	/OZ	ESIM index pulse, inverted
25	OB	ESIM channel B	26	DO4-	Digital output 4
27	-	Reserved	28	-	Reserved
29	-	Reserved	30	DI8-	Digital input 8
31	DI7-	Digital input 7	32	DI6-	Digital input 6
33	DI5-	Digital input 5	34	DI3-	Digital input 3
35	-	Reserved	36	-	Reserved
37	-	Reserved	38	-	Reserved
39	-	Reserved	40	-	Reserved
41	-	Reserved	42	-	Reserved
43	-	Reserved	44	-	Reserved
45	COM-	Reference potential to VDD and OCZ	46	-	Reserved
47	COM-	Reference potential to VDD and OCZ	48	OCZ	ESIM index pulse Open collector output
49	COM-	Reference potential to VDD and OCZ	50	OZ	ESIM index pulse Line driver output

⚠ WARNING

UNINTENDED EQUIPMENT OPERATION

Do not connect any wiring to reserved, unused connections, or to connections designated as No Connection (N.C.).

Failure to follow these instructions can result in death, serious injury, or equipment damage.

Inputs and Outputs Signals

The following inputs and outputs signals are available:

- Digital outputs (negative logic), page 102
- Digital outputs (positive logic), page 103
- Digital inputs (negative logic), page 104
- Digital inputs (positive logic), page 105
- Encoder output signal), page 106

Wiring of the Digital Outputs (Negative Logic)

Example of digital outputs DO1 ... DO4 with internal power supply (negative logic):

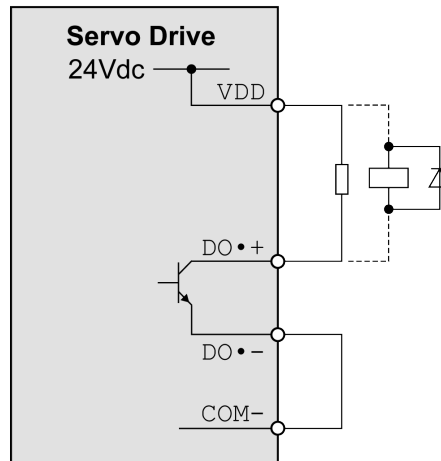

Example of digital outputs DO1 ... DO4 with external power supply (negative logic):

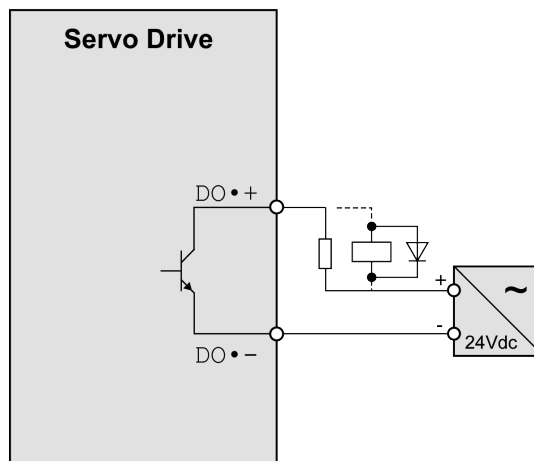

Example of digital output OCZ with internal power supply (negative logic):

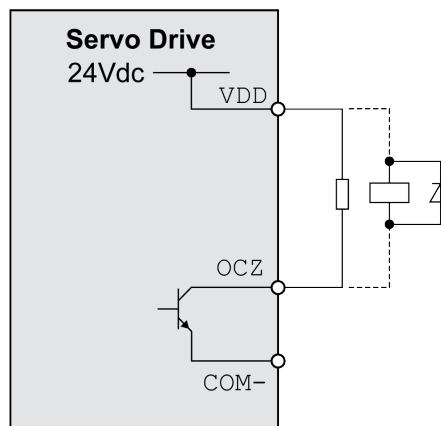

Example of digital output OCZ with external power supply (negative logic):

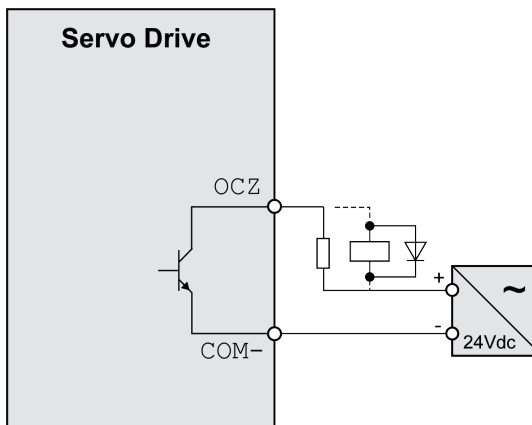

Inductive loads using DC voltages may damage the signal outputs. A protection circuit is required to protect the signal outputs against inductive loads.

⚠ CAUTION
OUTPUT CIRCUIT DAMAGE DUE TO INDUCTIVE LOADS
Use an appropriate external protective circuit or device to reduce the inductive direct current load damage.
Failure to follow these instructions can result in injury or equipment damage.

A diode can be used to protect the signal outputs against inductive loads.

Use a diode with the following ratings:

- Reverse withstand voltage: voltage of signal output times 10
- Forward current: greater than the load current

Wiring of the Digital Outputs (Positive Logic)

Example of digital outputs DO1 ... DO4 with internal power supply (positive logic):

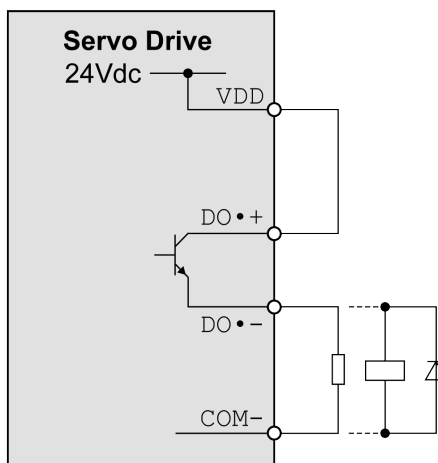

Example of digital outputs DO1 ... DO4 with external power supply (positive logic):

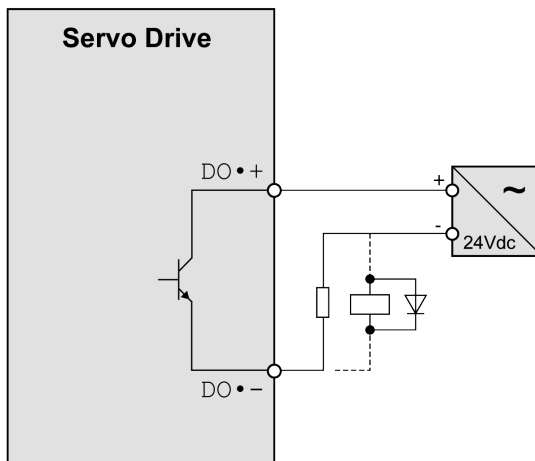

Inductive loads using DC voltages may damage the signal outputs. A protection circuit is required to protect the signal outputs against inductive loads.

⚠ CAUTION

OUTPUT CIRCUIT DAMAGE DUE TO INDUCTIVE LOADS

Use an appropriate external protective circuit or device to reduce the inductive direct current load damage.

Failure to follow these instructions can result in injury or equipment damage.

A diode can be used to protect the signal outputs against inductive loads. Use a diode with the following ratings:

Reverse withstand voltage: voltage of signal output times 10

Forward current: greater than the load current

Wiring of the Digital Inputs (Negative Logic)

⚠ WARNING

UNINTENDED EQUIPMENT OPERATION

Do not connect an external, 24 Vdc power supply to the VDD connection of the I/O interface (CN1) connector.

Failure to follow these instructions can result in death, serious injury, or equipment damage.

Use a relay or an open collector output (NPN transistor) for the input signal.

Example of digital input (negative logic) with internal power supply:

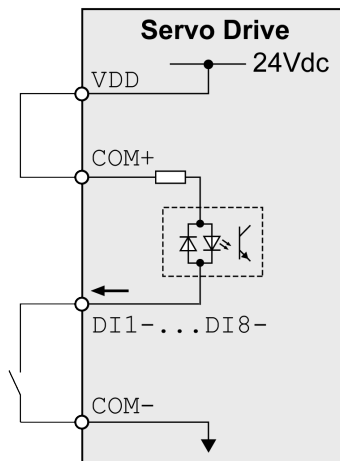

Example of digital input (negative logic) with external power supply:

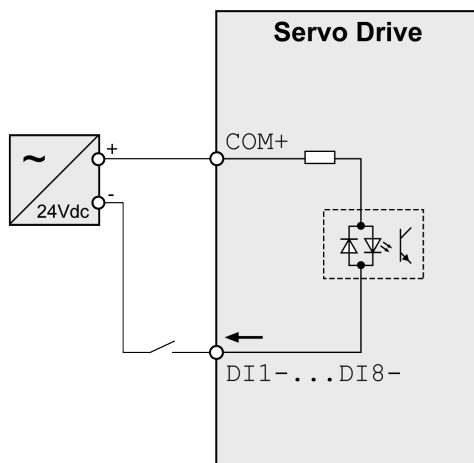

Wiring of the Digital Inputs (Positive Logic)

⚠ WARNING

UNINTENDED EQUIPMENT OPERATION

Do not connect an external, 24 Vdc power supply to the VDD connection of the I/O interface (CN1) connector.

Failure to follow these instructions can result in death, serious injury, or equipment damage.

Use a relay or an open collector output (PNP transistor) for the input signal.

Example of digital input with internal power supply (positive logic):

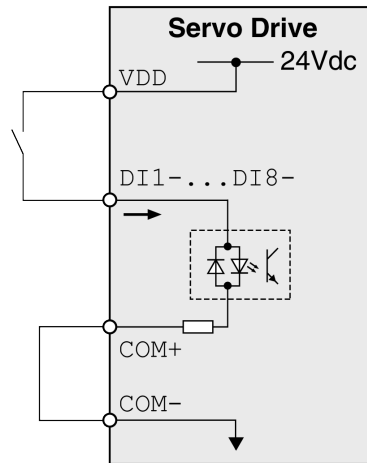

Example of digital input with external power supply (positive logic):

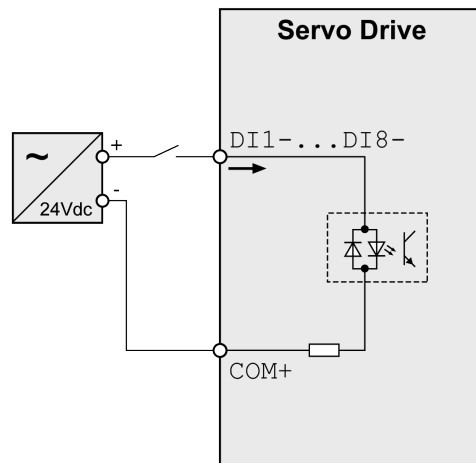

Encoder Output Signal

Example of encoder output signal Line Driver.

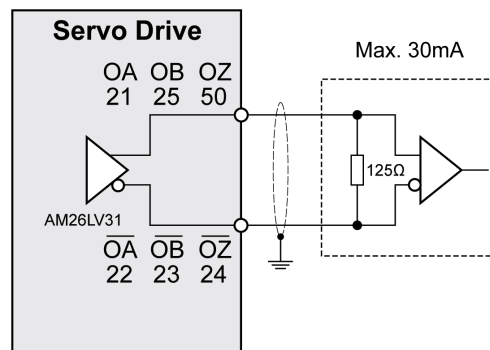

Example of encoder output signal, high-speed optocoupler.

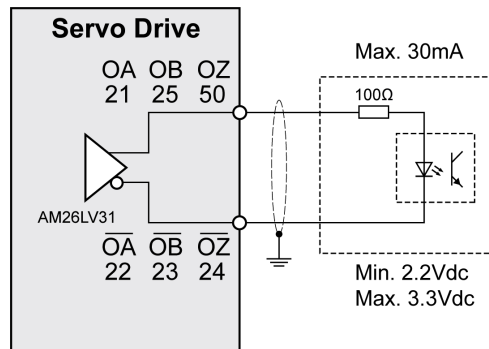

Connecting the Motor Encoder (CN2)

Function and Encoder Type

The motor encoder is an integrated, high-resolution absolute encoder. It provides the device with information on the motor position (analog and digital).

Compatibility between Drive and Motor is defined in the Drive / Motor combinations table, page 21.

Cable Specifications

For further information, refer to chapter Cables, page 74.

Shield:	Required, both ends grounded
Twisted Pair:	Required
PELV:	Required
Cable composition:	10 x 0.13 mm ² (10 x AWG 24)
Maximum cable length:	20 m (65.6 ft)
Special characteristics:	Fieldbus cables are not suitable for connecting encoders.

NOTE: Use pre-assembled cables to reduce the risk of wiring errors.

Wiring Diagram

Connection assignment motor encoder (CN2)

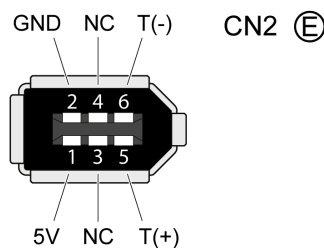

The motor encoder interface (CN2) is a 6-pin connector. The following table describes the contacts of the connector:

Pin	Signal	Color ⁽¹⁾	Meaning	Motor military connector	Motor plastic connector	I/O
5	T+	Blue (BU)	Serial communication	A	1	I/O
6	T-	Blue/Black (BU/BK)		B	4	
1	+5 V	Red, red/white (RD, RD/WH)	5 V encoder supply	S	7	I
2	GND	Black, black/white (BK, BK/WH)	Reference potential for encoder supply	R	8	O
3, 4	N.C.	Reserved	-	-	-	-

(1) Color information relates to the cables available as accessories.

⚠ WARNING

UNINTENDED EQUIPMENT OPERATION

Do not connect any wiring to reserved, unused connections, or to connections designated as No Connection (N.C.).

Failure to follow these instructions can result in death, serious injury, or equipment damage.

Connecting the Motor Encoder

- Verify that wiring, cables, and connected interface meet the PELV requirements.
- Note the information on EMC, see chapter *Electromagnetic Compatibility (EMC)*, page 71. Use equipotential bonding conductors for equipotential bonding.
- Connect the connector to
 - CN2 Encoder if using a motor equipped with a single-turn encoder.
 - the battery compartment if using a motor equipped with a multi-turn encoder.
- Verify that the connector locks snap in properly at the housing.

Route the cables from the motor and the encoder to the device (starting from the motor). Due to the pre-assembled connectors, this direction is often faster and easier.

Connecting the Battery Compartment When Using a Motor Equipped With a Multi-Turn Encoder

The battery compartment is connected to CN2 Encoder, between the drive and the motor encoder cable.

NOTE: The multi-turn counting is preserved through power down by the external battery located into the battery compartment.

For further information on the battery replacement, refer to the maintenance of the motor, page 266.

For LXM28S...UA5 ...U45, the battery compartment should be installed on a baseplate near the drive

Connection PC (CN3)

Function

The commissioning interface (CN3) is an RS-485 connection, supported on an RJ45 connector. If the PC used to connect to the commissioning interface has an RS-485 port, typically supported on a DB9 connector, you can connect it to this connector (RJ45 / DB9 cable). Otherwise, you can use the USB port of the PC with a USB to RS-485 converter.

The commissioning interface may only be used for a point-to-point connection, but not for a point-to-multipoint connection (RS-485 network).

If the commissioning interface at the product is directly connected to an Ethernet interface at the PC, the PC interface may be damaged and rendered inoperable.

NOTICE
INOPERABLE EQUIPMENT
Do not directly connect an Ethernet interface to the commissioning interface of this product.
Failure to follow these instructions can result in equipment damage.

Connecting a PC

A PC with the commissioning software LXM28 DTM Library can be connected for commissioning. The PC is connected via a bidirectional USB/RS485 converter, refer to Accessories and Spare Parts, page 65.

Cable Specifications

For further information, refer to chapter Cables, page 74.

Shield:	Required, both ends grounded
Twisted Pair:	Required
PELV:	Required
Cable composition:	8 x 0.25 mm ² (8 x AWG 22)
Maximum cable length:	100 m (328 ft)
Special characteristics:	-

Wiring Diagram

Wiring diagram PC with commissioning software

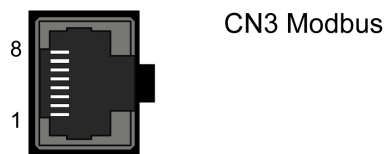

The commissioning interface (CN3) is an RJ45 connector. The following table describes the contacts of the connector:

Pin	Signal	Meaning	I/O
1 ... 3	-	Reserved	-
4	MOD_D1 ⁽¹⁾	Bidirectional transmit/receive signal	RS-485 level
5	MOD_D0 ⁽¹⁾	Bidirectional transmit/receive signal, inverted	
6 ... 7	-	Reserved	-
8 and connector housing	SHLD	Functional ground / shield - internally connected to ground potential of the drive	-

(1)	No polarization.
-----	------------------

⚠ WARNING

UNINTENDED EQUIPMENT OPERATION

Do not connect any wiring to reserved, unused connections, or to connections designated as No Connection (N.C.).

Failure to follow these instructions can result in death, serious injury, or equipment damage.

NOTE: Verify that the connector locks snap in properly at the housing.

Connection Fieldbus (CN4)

SERCOS III LED Diagnostic

The following figure shows the dual port/RJ45 connector

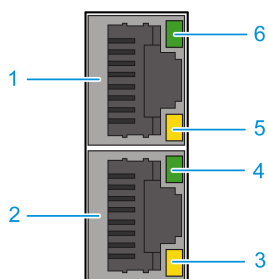

Item	Description
1	(X1) RJ45 connector
2	(X2) RJ45 connector

Item	Description
3	Link LED: <ul style="list-style-type: none"> Off: No connection, for example no cable connected or connected device has no power Yellow ON: Connection established
4	Activity LED: <ul style="list-style-type: none"> Green Flashing 2 Hz for 1 sec then Off: SERCOS III Phase is NRT Green ON: SERCOS III Communication phase 0 to 3 active Green Flashing 4 Hz: Communication phase 4 active
5	Link LED: <ul style="list-style-type: none"> Off: No connection, for example no cable connected or connected device has no power Yellow ON: Connection established
6	Activity LED: <ul style="list-style-type: none"> Green Flashing 2 Hz for 1 sec then Off: SERCOS III Phase is NRT Green ON: SERCOS III Communication phase 0 to 3 active Green Flashing 4 Hz: Communication phase 4 active

Pin Assignment

The following figure presents the RJ45 connector pin assignment:

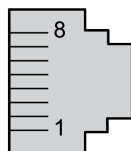

The table provides the pin out details of each RJ45 connector:

Pin	RJ45 signal	Description
1	TD+	Transmit data +
2	TD-	Transmit data -
3	RD+	Receive data +
4	-	Not connected
5	-	Not connected
6	RD-	Receive data -
7	-	Not connected
8	-	Not connected

Cable Specification

- Minimum Cat 5e
- Use equipotential bonding conductors
- Shield: both ends grounded
- Twisted-pair cable
- Cable: 8 x 0.25 mm² (8x AWG 22)
- Use pre-assembled cables to reduce the wiring mistakes
- Verify that wiring, cables, and connected interfaces meet the PELV requirements
- Maximum cable length between devices = 100 m (328 ft)

Use the Schneider Electric cables, page 66.

Connection Logic Supply and Power Stage Supply (CN5)

This product has a leakage (touch) current greater than 3.5 mA. If the protective ground connection is interrupted, a hazardous leakage (touch) current may flow if the housing is touched.

⚡⚠ DANGER
<p>INSUFFICIENT GROUNDING</p> <ul style="list-style-type: none"> • Use a protective ground conductor with at least 10 mm² (AWG 6) or two protective ground conductors with the cross section of the conductors supplying the power terminals. • Verify compliance with all local and national electrical code requirements as well as all other applicable regulations with respect to grounding of the entire drive system. • Ground the drive system before applying voltage. • Do not use conduits as protective ground conductors; use a protective ground conductor inside the conduit. • Do not use cable shields as protective ground conductors. • Keep foreign objects from getting into the product. • Verify the correct seating of seals and cable entries in order to avoid contamination such as deposits and humidity. <p>Failure to follow these instructions will result in death or serious injury.</p>

⚠ WARNING
<p>INSUFFICIENT PROTECTION AGAINST OVERCURRENT</p> <ul style="list-style-type: none"> • Use the external fuses specified in chapter “Technical Data”. • Do not connect the product to a supply mains whose short-circuit current rating (SCCR) exceeds the value specified in the chapter “Technical Data”. <p>Failure to follow these instructions can result in death, serious injury, or equipment damage.</p>

⚠ WARNING
<p>INCORRECT MAINS VOLTAGE</p> <p>Verify that the product is approved for the mains voltage before applying power and configuring the product.</p> <p>Failure to follow these instructions can result in death, serious injury, or equipment damage.</p>

The equipment, drives and motors, are intended for industrial use and may only be operated with a permanently installed connection.

Prior to connecting the equipment, verify the approved mains types, see chapter Electrical Data Drive, page 32.

Cable Specifications

Respect the required cable properties in chapter Cables, page 74 and in chapter Electromagnetic Compatibility (EMC), page 71.

Shield:	-
Twisted Pair:	-
PELV:	-

Cable composition:	The conductors must have a sufficiently large cross section so that the fuse at the mains connection can trip if required.
Maximum cable length:	3 m (9.84 ft)
Special characteristics:	-

Properties of the Terminals

The terminals are approved for stranded conductors and solid conductors. Use cable ends (ferrules), if possible.

LXM28S	Unit	UA5, U01, U02, U04, U07, U10, U15	U20, U30, U45
Connection cross section	mm ² (AWG)	0.75 ... 2.5 (20 ... 14)	0.75 ... 6 (20 ... 10)
Stripping length	mm (in)	8 ... 9 (0.31 ... 0.35)	15 (0.59)

Prerequisites for Connecting the Logic Supply

Note the following information:

- Use upstream mains fuses. For further information about fuse types and fuse ratings, refer to chapter [Electrical Data Drive](#), page 32.
- Note the EMC requirements. Where required, use surge arresters and mains reactors.
- If the length of the mains cable between the external mains filter and the drive exceeds 200 mm (7.87 in), it must be shielded and grounded at both ends.
- For a UL-compliant design, refer to chapter [Conditions for UL 508C](#), page 25.

Connection Logic Supply

Wiring diagram logic supply LXM28S•••M3X

UA5, U01, U02, U04, U07, U10, U15, U20, U30, U45

~220V

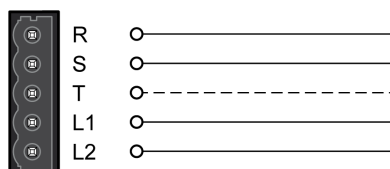

Connection	Meaning
R, S, (T)	Power stage supply
L1, L2	Logic supply

- Verify the type of mains. For the approved types of mains, refer to chapter [Electrical Data Drive](#), page 32.
- Connect the mains cable.
- Verify that the connector locks snap in properly at the housing.

Wiring Diagram for Devices That Can Be Connected Via a Single-Phase or Three Phases

Drives with a continuous power from 50 W to 1500 W can be connected via a single-phase or via three phases. Drives with a continuous power of more than 1500 W must be connected via three phases.

Wiring diagram for devices that can be connected via a single-phase or three-phases

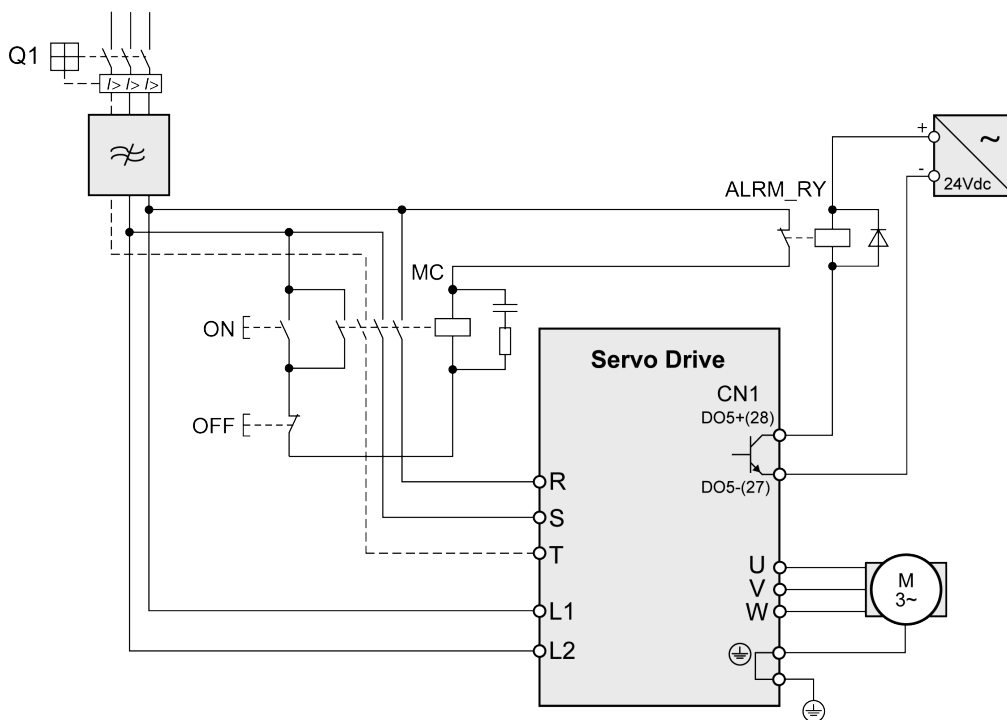

Connection DC Bus (CN6)

Incorrect use of the DC bus may permanently damage the drives either immediately or over time.

⚠ WARNING

INOPERABLE SYSTEM COMPONENTS AND LOSS OF CONTROL

Verify that all requirements for using the DC bus are met.

Failure to follow these instructions can result in death, serious injury, or equipment damage.

This and other important information can be found in the "LXM28 - Common DC bus - Application note", page 11. If you wish to take advantage of DC bus sharing, you must first consult the LXM28 - Common DC bus - Application note for important safety-related information.

Requirements for Use

The requirements and limit values for parallel connection of multiple devices via the DC bus can be found on www.se.com in the form of an application note (refer to chapter Related Documents, page 11).

Connection Braking Resistor (CN7)

An insufficiently rated braking resistor can cause overvoltage on the DC bus. Overvoltage on the DC bus causes the power stage to be disabled. The motor is no longer actively decelerated.

⚠ WARNING
UNINTENDED EQUIPMENT OPERATION
<ul style="list-style-type: none"> • Verify that the braking resistor has a sufficient rating by performing a test run under maximum load conditions. • Verify that the parameter settings for the braking resistor are correct.
Failure to follow these instructions can result in death, serious injury, or equipment damage.

Internal Braking Resistor

A braking resistor is integrated in the device to absorb braking energy. The drive is shipped with the internal braking resistor active.

External Braking Resistor

An external braking resistor is required for applications in which the motor must be decelerated quickly and the internal braking resistor cannot absorb the excess braking energy.

Selection and rating of the external braking resistor are described in chapter Rating the Braking Resistor, page 88. For suitable braking resistors, refer to chapter Accessories and Spare Parts, page 68.

Cable Specifications

For further information, refer to chapter Cables, page 74.

Shield:	Required, both ends grounded
Twisted Pair:	-
PELV:	-
Cable composition:	Minimum conductor cross section: Same cross section as logic supply. The conductors must have a sufficiently large cross section so that the fuse at the mains connection can trip if required.
Maximum cable length:	3 m (9.84 ft)
Special characteristics:	Temperature resistance

The braking resistors listed in chapter Accessories and Spare Parts, page 68 have a 3-wire, temperature-resistant cable with a length of 0.75 m (2.46 ft) to 3 m (9.84 ft).

Properties of the Terminals (CN7) LXM28SUA5, U01, U02, U04, U07, U10, U15, U20, U30, U45

The terminals are approved for stranded conductors and solid conductors. Use cable ends (ferrules), if possible.

LXM28S	Unit	UA5, U01, U02, U04, U07, U10, U15	U20, U30, U45
Connection cross section	mm ² (AWG)	0.75 ... 2.5 (20 ... 14)	0.75 ... 6 (20 ... 10)
Stripping length	mm (in)	8 ... 9 (0.31 ... 0.35)	15 (0.59)

The removable terminals are approved for fine-stranded conductors and solid conductors. Respect the maximum permissible connection cross section. Take into account the fact that cable ends (ferrules) increase the conductor cross section.

NOTE: If you use cable ends (ferrules), use only cable ends (ferrules) with collars for these terminals.

Wiring Diagram

Wiring diagram internal braking resistor activated

LXM28SUA5...U45

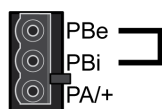

Wiring diagram external braking resistor

LXM28SUA5...U45

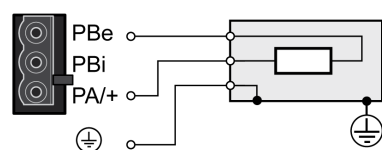

Connecting the External Braking Resistor

- Remove power from all supply voltages. Respect the safety instructions concerning electrical installation.
- Verify that no voltages are present.
- Ground the ground connection (PE) of the braking resistor.
- Connect the external braking resistor to the device.
- Connect a large surface area of the cable shield to the central grounding point of your system.

⚠️⚠️ DANGER**ELECTRIC SHOCK, EXPLOSION OR ARC FLASH**

- Disconnect all power from all equipment including connected devices prior to removing any covers or doors, or installing or removing any accessories, hardware, cables, or wires.
- Place a "Do Not Turn On" or equivalent hazard label on all power switches and lock them in the non-energized position.
- Wait 15 minutes to allow the DC bus capacitors to properly discharge.
- Measure the DC bus voltage between the DC bus terminals (PA/+ and PC/-) to verify that DC bus capacitors are properly discharged (voltage less than 42.4 Vdc).
- Do not assume that the DC bus discharged properly when the DC bus LED is off.
- Block the motor shaft to prevent rotation prior to performing any type of work on the drive system.
- Do not create a short-circuit across the DC bus terminals or the DC bus capacitors.
- Replace and secure all covers, accessories, hardware, cables, and wires and confirm that a proper ground connection exists before applying power to the unit.
- Use only the specified voltage when operating this equipment and any associated products.

Failure to follow these instructions will result in death or serious injury.

Connecting the Motor Phases (CN8)

High voltages may be present at the motor connection. The motor itself generates voltage when the motor shaft is rotated. AC voltage can couple voltage to unused conductors in the motor cable.

⚠️⚠️ DANGER**ELECTRIC SHOCK**

- Verify that no voltage is present prior to performing any type of work on the drive system.
- Block the motor shaft to prevent rotation prior to performing any type of work on the drive system.
- Insulate both ends of unused conductors of the motor cable.
- Supplement the motor cable grounding conductor with an additional protective ground conductor to the motor housing.
- Verify compliance with all local and national electrical code requirements as well as all other applicable regulations with respect to grounding of all equipment.

Failure to follow these instructions will result in death or serious injury.

Incorrect wiring of the motor connection may cause live wires to be exposed outside of the motor connector below the HMI.

⚡⚠ DANGER

ELECTRIC SHOCK CAUSED BY INCORRECT WIRING

- Verify that the protective ground connection (PE) of the device is connected to ground.
- Do not remove the cable end (ferrule) from the protective ground terminal (PE) of the motor connector until you are prepared to wire the protective ground conductor of the motor to the protective ground terminal (PE) of the motor connector.
- Verify that no bare metal of the wires is exposed outside of the motor connector housing when wiring the motor connector.
- Regularly, as part of a maintenance plan, assure that the motor wires are secured in the terminals of the motor connector due to vibration or other influences.

Failure to follow these instructions will result in death or serious injury.

Drive systems may perform unintended movements if unapproved combinations of drive and motor are used. Even if motors are similar, different adjustment of the encoder system may be a source of hazards. Even if the connectors for motor connection and encoder connection match mechanically, this does not imply that the motor is approved for use.

⚠ WARNING

UNINTENDED MOVEMENT

Only use approved combinations of drive and motor.

Failure to follow these instructions can result in death, serious injury, or equipment damage.

Compatibility between Drive and Motor is defined in the Drive / Motor combinations table, page 21.

Route the cables from the motor and the encoder to the device (starting from the motor). Due to the pre-assembled connectors, this direction is often faster and easier.

Cable Specifications

For further information, refer to chapter Cables, page 74.

Shield:	Required, both ends grounded
Twisted Pair:	-
PELV:	The wires for the holding brake must be PELV-compliant.
Cable composition:	3 wires for motor phases The conductors must have a sufficiently large cross section so that the fuse at the mains connection can trip if required.
Maximum cable length:	Depends on the required limit values for conducted interference. Category C3: 20 m (65.6 ft)
Special characteristics:	Contains wires for the temperature sensor

Note the following information:

- You may only connect the original motor cable.
- If you do not connect the wires at the motor end, you must isolate each wire individually (inductive voltages).

- Use pre-assembled cables to reduce the risk of wiring errors.

Properties of the Terminals (CN8)

The terminals are approved for stranded conductors and solid conductors. Use cable ends (ferrules), if possible.

LXM28S	Unit	UA5, U01, U02, U04, U07, U10, U15	U20, U30, U45
Connection cross section	mm ²	0.75 ... 2.5	0.75 ... 6
	(AWG)	(20 ... 14)	(20 ... 10)
Stripping length	mm	8 ... 9	15
	(in)	(0.31 ... 0.35)	(0.59)

Monitoring

The drive monitors the motor phases for:

- Short circuit between the motor phases
- Short circuit between the motor phases and ground (Not applicable for LXM28SUA5 ... U07 M3X.)

Short circuits between the motor phases and the DC bus, the braking resistor, or the holding brake wires are not detected.

When a short-circuit is detected, power is removed by disabling the power stage. The firmware reports error AL001. Once you have resolved the issue of the over-current, you can re-enable the power stage of the drive.

NOTE: After three successive unsuccessful retries of resetting the power stage, the reset will be blocked for a minimum of one minute.

Wiring Diagram Motor

LXM28SUA5...U45

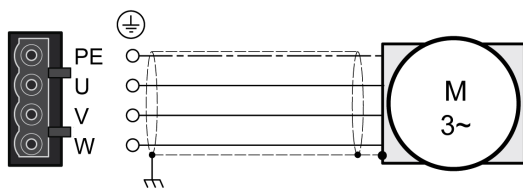

Connection	Meaning	Color ⁽¹⁾ (IEC 757)
U	Motor phase	Red (RD)
V		White (WH)
W		Black (BK)
PE	Protective ground conductor	Green/Yellow (GN/YE)
(1)	Color information relates to the cables available as accessories.	

Connecting the Motor Cable

- Note the information on EMC, refer to chapter Electromagnetic Compatibility (EMC), page 71.
- Connect the motor phases and protective ground conductor to CN8. Verify that the connections U, V, W, and PE (ground) match at the motor and the device.
- If the product is equipped with removable connectors, Verify that the connector locks snap in properly at the housing.

Holding Brake Connection

The holding brake in the motor has the task of holding the motor position when the power stage is disabled. The holding brake is not a safety function and not a service brake.

A motor with a holding brake requires a suitable holding brake controller which releases the brake when the power stage is enabled and locks the motor shaft when the power stage is disabled.

The holding brake is connected to one of the digital outputs **DO1...DO4**. The signal output function BRKR must be assigned to the digital output to which the holding brake is connected. The signal output function BRKR releases the holding brake when the power stage is enabled. When the power stage is disabled, the holding brake is reapplied.

The factory settings for the signal outputs depend on the operating mode, see chapter Setting the Digital Signal Outputs, page 226. Depending on the operating mode, the signal output function is either assigned to the digital output DO4 or not assigned at all. When you reset the drive to the factory settings with P2-08 = 10, the assignments of the signal output functions are also reset to the factory settings.

When you switch the operating mode using the parameter P1-01 or the signal input functions V-Px and V-T, the signal output functions may also be reset to the factory settings for the new operating mode. If you use the setting D = 0 of parameter P1-01, the assignment of the signal output functions remains the same in the new operating mode.

Resetting the drive to the factory settings or switching the operating mode can modify the assignment of the signal output functions in such a way that the holding brake is released unintentionally.

▲ WARNING

UNINTENDED EQUIPMENT OPERATION

- Verify that the digital output to which you have assigned the signal output function BRKR has been properly wired and configured.
- Before switching to a different operating mode, verify that the signal output function BRKR for the holding brake will not be assigned to an incorrect digital output in the new operating mode.
- Before resetting the drive to the factory settings, verify that the signal output function BRKR for the holding brake will be assigned to the correct digital output or reassign the signal output function BRKR after the factory reset according to the requirements of your application prior to starting the system.
- In all cases, take all necessary measures to prevent unintended movements of the load caused by a release of the holding brake.

Failure to follow these instructions can result in death, serious injury, or equipment damage.

Example (negative logic) of wiring the holding brake

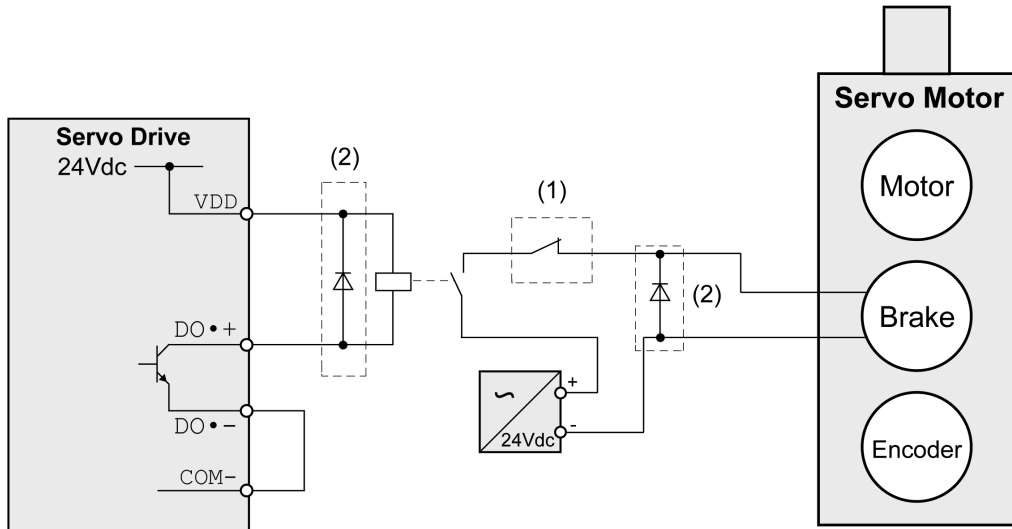

Item	Description
1	Triggering an EMERGENCY STOP should apply the holding brake
2	Flyback diode

Connection STO (CN9)

For important safety information, refer to the chapter *Safety Function STO (Safe Torque Off)*, page 76 for the requirements for using the safety function STO.

Cable Specifications - Cables Outside of Control Cabinet

Shield:	Yes
Twisted Pair:	Yes
PELV:	Required
Minimum conductor cross section:	2 x 0.34 mm ² (AWG 22)
Maximum cable length:	30 m (98.4 ft)
Fuse:	4 A

A fault exclusion is required such that it is not possible to short circuit the STO by another voltage carrying line. For the STO Cables defined by EN 61800-5-2:2007 Table D.1 or EN 61800-5-2:2017 with reference to ISO 13849-1 Table D.4.: For the required fault exclusion the cables must be permanently connected (fixed) and protected against external damage, for example by cable ducting or armored cables (steel jacket or ridged shielding).

Cable Specifications - Cables Inside Control Cabinet

Shield:	Yes
Twisted Pair:	No
PELV:	Required
Minimum conductor cross section:	2 x 0.25 mm ² (AWG 24)

Maximum cable length:	3 m (9.84 ft)
Fuse:	4 A

Properties of the Connection

Connectors housing	Molex 436450400 ⁽¹⁾	
Connectors crimp contact	Molex 430300001 ⁽¹⁾	
Connection cross section	mm ²	0.25 ... 0.34
	(AWG)	(24 ... 22)
(1) Or corresponding equivalent.		

Wiring Diagram

Wiring diagram safety function STO

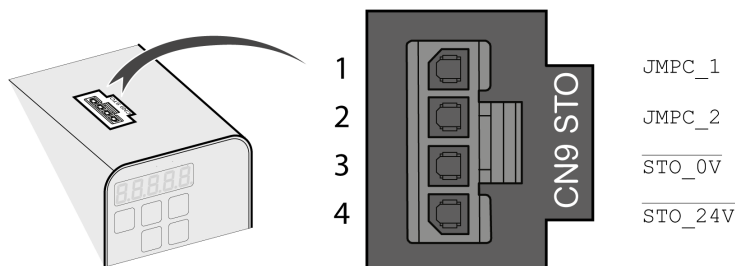

The STO interface (CN9) is a 4-pin female connector. The following table describes the contacts of the connector:

Pin	Signal	Meaning
1	JMPC_1	Jumper connector 1 to be connected to STO_24V if the safety function STO is not used in your application
2	JMPC_2	Jumper connector 2 to be connected to STO_0V if the safety function STO is not used in your application
3	STO_0V	Safety function STO 0 Vdc input ⁽¹⁾
4	STO_24V	Safety function STO 24 Vdc input ⁽¹⁾
(1) PELV power supply is required.		

Connecting the Safety Function STO

- Verify that wiring, cables, and connected interfaces meet the PELV requirements.
- Connect the safety function STO in accordance with the specifications in chapter Safety Function STO (Safe Torque Off), page 76.

Deactivating the Safety Function STO

If the safety function STO is not to be used, it must be deactivated. Plug in the jumper for CN9 to bridge pin 1 and pin 4 as well as pin 2 and pin 3 to deactivate the safety function STO. The jumper for CN9 is factory-fitted.

Deactivating the safety function STO

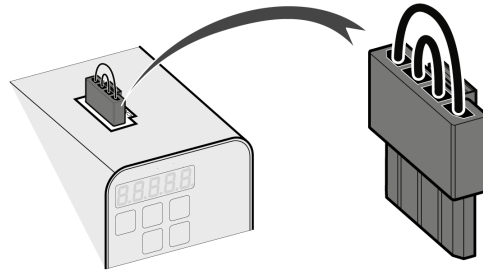

⚠ WARNING

UNINTENDED EQUIPMENT OPERATION

- Remove the jumpers connected to the STO power connector (CN9) only if you intend to use the STO safety-related function for your application.
- Use only an external PELV 24 Vdc power supply unit when applying the safety-related STO function.

Failure to follow these instructions can result in death, serious injury, or equipment damage.

Motor Installation

What's in This Chapter

Mechanical Installation Motor	124
Connections and Pin Assignments.....	127
Connection of Motor and Encoder.....	129
Holding Brake Connection	131

Mechanical Installation Motor

Motors are very heavy relative to their size. The mass of the motor can cause injuries and damage.

▲ WARNING

HEAVY AND/OR FALLING PARTS

- Use a suitable crane or other suitable lifting gear for mounting the motor if this is required by the weight of the motor.
- Use the necessary personal protective equipment (for example, protective shoes, protective glasses and protective gloves).
- Mount the motor so that it cannot come loose (use of securing screws with appropriate tightening torque), especially in cases of fast acceleration or continuous vibration.

Failure to follow these instructions can result in death, serious injury, or equipment damage.

Motors can generate strong local electrical and magnetic fields. This can cause interference in sensitive devices.

▲ WARNING

ELECTROMAGNETIC FIELDS

- Keep persons with electronic medical implants, such as pacemakers, away from the motor.
- Do not place electromagnetically sensitive devices in the vicinity of the motor.

Failure to follow these instructions can result in death, serious injury, or equipment damage.

The metal surfaces of the product may exceed 70 °C (158 °F) during operation.

▲ WARNING

HOT SURFACES

- Avoid unprotected contact with hot surfaces.
- Do not allow flammable or heat-sensitive parts in the immediate vicinity of hot surfaces.
- Verify that the heat dissipation is sufficient by performing a test run under maximum load conditions.

Failure to follow these instructions can result in death, serious injury, or equipment damage.

⚠ CAUTION

IMPROPER APPLICATION OF FORCES

- Do not use the motor as a step to climb into or onto the machine.
- Do not use the motor as a load-bearing part.
- Use hazard labels and guards on your machine to help prevent the improper application of forces on the motor.

Failure to follow these instructions can result in injury or equipment damage.

Mounting Position

The following mounting positions are defined and permissible as per IEC 60034-7:

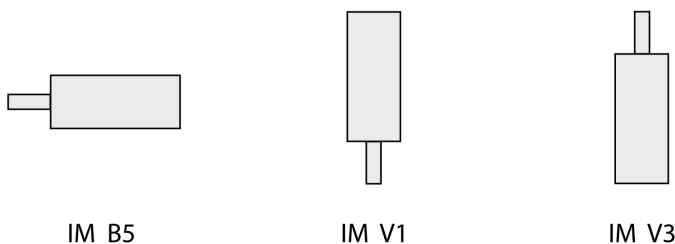

Mounting

When the motor is mounted to the mounting surface, it must be accurately aligned axially and radially and make even contact with the mounting surface. All mounting screws must be tightened with the specified tightening torque. No uneven mechanical load may be applied while the mounting screws are tightened. For data, dimensions, and degrees of protection (IP), refer to chapter *Motor*, page 39.

Mounting Situation

NOTICE

FORCES APPLIED TO THE REAR SIDE OF THE MOTOR

- Do not place the motor on the rear side.
- Protect the rear side of the motor from impact.
- Do not lift motors via the rear side.
- Only lift motors equipped with eyebolts via the eyebolts.

Failure to follow these instructions can result in equipment damage.

Special Characteristics BCH2•H, BCH2•M, BCH2•R

Rear side of motor

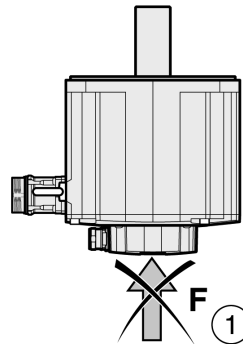

Item	Description
1	Protect the rear side of the motor from application of forces.

Eyebolts BCH2•R

Consider the mass of the product when mounting the motor. It may be necessary to use suitable lifting gear.

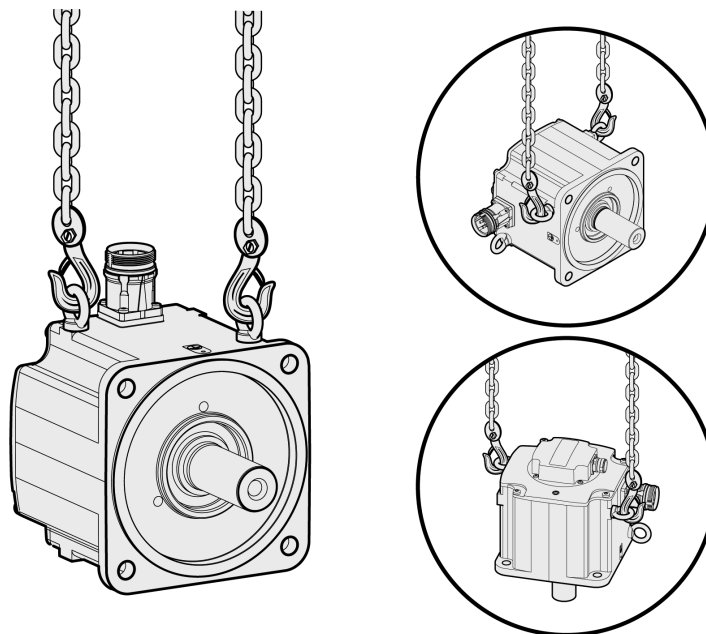

Connections and Pin Assignments

Connection overview

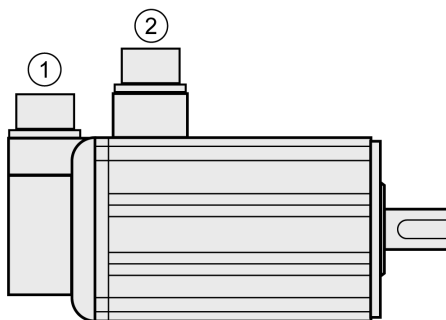

Item	Description
1	Encoder connection
2	Motor connection

Pin Assignment Motor Connection

Pin assignments of motor phases and holding brake

Motor connection plastic connector (type A and type B), drive side:



Motor connection MIL connector (type C and type D), motor side:

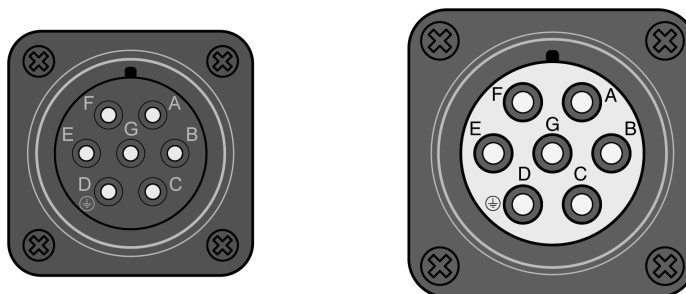

Pin Type A	Pin Type B	Pin Type C and D	Signal	Meaning	Color ⁽¹⁾ (IEC 757)	
					Plastic connector	ML connector
1	1	E	U	Motor phase U	Grey (GY)	White (WH)
2	2	G	V	Motor phase V	Black (BK)	Black (BK)
3	4	B	W	Motor phase W	Brown (BN)	Red (RD)
4	5	D	PE	Protective ground (protective earth)	Green/Yellow (GN/YE)	Green/Yellow (GN/YE)

–	3	F	BRAKE_24V	Supply voltage holding brake 24 Vdc	Brown (BN)	Red (RD)
–	6	A	BRAKE_0V	Reference potential holding brake 0 Vdc	White (WH)	Black (BK)
–	–	C	–	Reserved	–	–

(1) Color information relates to the cables available as accessories.

⚠ WARNING

UNINTENDED EQUIPMENT OPERATION

Do not connect any wiring to reserved, unused connections, or to connections designated as No Connection (N.C.).

Failure to follow these instructions can result in death, serious injury, or equipment damage.

Pin Assignment Encoder Connection

Pin assignment of the encoder.

Encoder connection plastic connector (Type A), drive side:

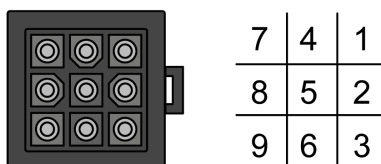

Encoder connection MIL connector (Type B), motor side:

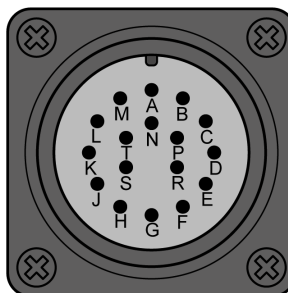

Pin Type A	Pin Type B	Signal	Meaning	Color ⁽¹⁾ (IEC 757)
1	A	T+	Data	Blue (BU)
2	C	–	Reserved	–
3	D	–	Reserved	–
4	B	T-	Data	Blue/Black (BU/BK)
5	F	Battery +	Battery + ⁽²⁾	Red (RD)
6	G	Battery -	Battery - ⁽²⁾	Black (BK)
7	S	DC+5 V	Supply voltage	Red/White (RD/WH)
8	R	GND	Reference potential	Black/White (BK/WH)
9	L	Shield	Shield	Black (BK)
–	E	–	Reserved	–

Pin Type A	Pin Type B	Signal	Meaning	Color ⁽¹⁾ (IEC 757)
–	H	–	Reserved	–
–	J	–	Reserved	–
–	K	–	Reserved	–
–	M	–	Reserved	–
–	N	–	Reserved	–
–	P	–	Reserved	–
–	T	–	Reserved	–

(1) Color information relates to the cables available as accessories.
 (2) Used with multi-turn encoders.

⚠ WARNING

UNINTENDED EQUIPMENT OPERATION

Do not connect any wiring to reserved, unused connections, or to connections designated as No Connection (N.C.).

Failure to follow these instructions can result in death, serious injury, or equipment damage.

Mating Connector

For suitable mating connectors, refer to chapter Connectors and Adapters, page 65.

Connection of Motor and Encoder

The motor is designed for operation via a drive. Connecting the motor directly to line voltage will damage the motor and can cause fires.

⚠ DANGER

FIRE HAZARD DUE TO INCORRECT CONNECTION

Only connect the motor to a matching, approved drive.

Failure to follow these instructions will result in death or serious injury.

Compatibility between Drive and Motor is defined in the Drive / Motor combinations table, page 21.

High voltages may be present at the motor connection. The motor itself generates voltage when the motor shaft is rotated. AC voltage can couple voltage to unused conductors in the motor cable.

⚡⚠ DANGER**ELECTRIC SHOCK**

- Verify that no voltage is present prior to performing any type of work on the drive system.
- Block the motor shaft to prevent rotation prior to performing any type of work on the drive system.
- Insulate both ends of unused conductors of the motor cable.
- Supplement the motor cable grounding conductor with an additional protective ground conductor to the motor housing.
- Verify compliance with all local and national electrical code requirements as well as all other applicable regulations with respect to grounding of all equipment.

Failure to follow these instructions will result in death or serious injury.

Drive systems may perform unintended movements if unapproved combinations of drive and motor are used. Even if motors are similar, different adjustment of the encoder system may be a source of hazards. Even if the connectors for motor connection and encoder connection match mechanically, this does not imply that the motor is approved for use.

⚠ WARNING**UNINTENDED MOVEMENT**

Only use approved combinations of drive and motor.

Failure to follow these instructions can result in death, serious injury, or equipment damage.

Compatibility between Drive and Motor is defined in the Drive / Motor combinations table, page 21.

Protective Ground Conductor Connection



- Ground the motor via a grounding screw if grounding via the flange and the protective ground conductor of the motor cable is not sufficient.
- Use parts with suitable corrosion protection.

Connecting the Cables

Incorrect installation of the cable may destroy the insulation. Broken conductors in the cable or improperly connected connectors may be melted by arcs.

⚡⚠ DANGER

ELECTRIC SHOCK, ARC FLASH AND FIRE CAUSED BY INCORRECT INSTALLATION OF THE CABLE

- Disconnect all power before plugging in or unplugging the connectors.
- Verify correct pin assignment of the connectors according to the specifications in this chapter before connecting the cables.
- Verify that the connectors are properly inserted and locked before applying power.
- Avoid forces or movements of the cable at the cable entries.

Failure to follow these instructions will result in death or serious injury.

- Connect the motor cable and the encoder cable to the drive according to the wiring diagram of the drive.
- If your motor is equipped with a holding brake, follow the instructions in chapter Holding Brake Connection, page 131.

Holding Brake Connection

The holding brake in the motor has the task of holding the motor position when the power stage is disabled. The holding brake is not a safety function and not a service brake.

A motor with a holding brake requires a suitable holding brake controller which releases the brake when the power stage is enabled and locks the motor shaft when the power stage is disabled.

See chapter Holding Brake Connection, page 120 for additional information.

As a result of damage to the insulation of the motor cable, mains voltage may get to the wires for the holding brake.

⚡⚠ DANGER

ELECTRIC SHOCK CAUSED BY DAMAGE TO THE MOTOR CABLE

- Use a PELV power supply for the holding brake.
- Insulate both ends of unused conductors of the motor cable.

Failure to follow these instructions will result in death or serious injury.

When the product is operated for the first time, there is a risk of unanticipated movements caused by, for example, incorrect wiring or unsuitable parameter settings. Releasing the holding brake can cause an unintended movement, for example, lowering of the load in the case of vertical axes.

⚠ WARNING

UNINTENDED MOVEMENT

- Verify that there are no persons or obstacles in the zone of operation when performing a test of the holding brake.
- Take appropriate measures to avoid damage caused by falling or lowering loads or other unintended movements.
- Run initial tests without coupled loads.
- Verify that a functioning emergency stop push-button is within reach of all persons involved in running tests.
- Anticipate movements in unintended directions or oscillations of the motor.

Failure to follow these instructions can result in death, serious injury, or equipment damage.

Cable Specifications

For further information on cable specifications, refer to chapter Cables, page 74.

Verifying Installation

What's in This Chapter

Verifying Installation 133

Verifying Installation

Verify the mechanical installation of the entire drive system:

- Does the installation meet the specified distance requirements?
- Did you tighten all fastening screws with the specified tightening torque?

Verify the electrical connections and the wiring:

- Did you connect all protective ground conductors?
- Do all fuses have the correct rating; are the fuses of the specified type?
- Did you connect all wires of the cables or insulate them?
- Did you properly connect and install all cables and connectors?
- Are the mechanical locks of the connectors correct and effective?
- Did you properly connect the signal wires?
- Are the required shield connections EMC-compliant?
- Did you take all measures for EMC compliance?
- Does the drive installation conform to all local, regional, and national electrical safety codes for the eventual placement of the equipment?

Verify that all covers and seals of the control cabinet are properly installed to meet the required degree of protection.

Commissioning

What's in This Part

Overview	135
Integrated HMI	138
Commissioning Procedure	143
Tuning the Control Loops	149

Overview

What's in This Chapter

General 135
 Commissioning Tools..... 137

General

You must recommission an already configured device if you want to use it under different operating conditions.

The safety function STO (Safe Torque Off) does not remove power from the DC bus. The safety function STO only removes power to the motor. The DC bus voltage and the mains voltage to the drive are still present.

⚠️⚠️ DANGER
<p>ELECTRIC SHOCK</p> <ul style="list-style-type: none"> Do not use the safety function STO for any other purposes than its intended function. Use an appropriate switch, that is not part of the circuit of the safety function STO, to disconnect the drive from the mains power. <p>Failure to follow these instructions will result in death or serious injury.</p>

Unsuitable settings or unsuitable data may trigger unintended movements, trigger signals, damage parts and disable monitoring functions. Some parameters and other operational data do not become active until after a restart.

⚠️ WARNING
<p>UNINTENDED EQUIPMENT OPERATION</p> <ul style="list-style-type: none"> Only start the system if there are no persons or obstructions in the zone of operation. Do not operate the drive system with undetermined parameter values. Never modify a parameter value unless you fully understand the parameter and all effects of the modification. Restart the drive and verify the saved operational data and/or parameter values after modification. Carefully run tests for all operating states and potential error situations when commissioning, upgrading or otherwise modifying the operation of the drive. Verify the functions after replacing the product and also after making modifications to the parameter values and/or other operational data. <p>Failure to follow these instructions can result in death, serious injury, or equipment damage.</p>

If the power stage is disabled unintentionally, for example as a result of a power outage, errors or functions, the motor is no longer decelerated in a controlled way.

⚠️ WARNING
<p>UNINTENDED EQUIPMENT OPERATION</p> <p>Verify that movements without braking effect cannot cause injuries or equipment damage.</p> <p>Failure to follow these instructions can result in death, serious injury, or equipment damage.</p>

Applying the holding brake while the motor is running will cause excessive wear and loss of the braking force.

⚠ WARNING

LOSS OF BRAKING FORCE DUE TO WEAR OR HIGH TEMPERATURE

- Do not use the holding brake as a service brake.
- Do not exceed the maximum number of brake applications and the kinetic energy during braking of moving loads.

Failure to follow these instructions can result in death, serious injury, or equipment damage.

The metal surfaces of the product may exceed 70 °C (158 °F) during operation.

⚠ WARNING

HOT SURFACES

- Avoid unprotected contact with hot surfaces.
- Do not allow flammable or heat-sensitive parts in the immediate vicinity of hot surfaces.
- Verify that the heat dissipation is sufficient by performing a test run under maximum load conditions.

Failure to follow these instructions can result in death, serious injury, or equipment damage.

Rotating parts may cause injuries and may catch clothing or hair. Loose parts or parts that are out of balance may be ejected.

⚠ WARNING

MOVING, UNGUARDED EQUIPMENT

Verify that rotating parts cannot cause injuries or equipment damage.

Failure to follow these instructions can result in death, serious injury, or equipment damage.

When the product is operated for the first time, there is a risk of unanticipated movements caused by, for example, incorrect wiring or unsuitable parameter settings. Releasing the holding brake can cause an unintended movement, for example, lowering of the load in the case of vertical axes.

⚠ WARNING

UNINTENDED MOVEMENT

- Verify that there are no persons or obstacles in the zone of operation when performing a test of the holding brake.
- Take appropriate measures to avoid damage caused by falling or lowering loads or other unintended movements.
- Run initial tests without coupled loads.
- Verify that a functioning emergency stop push-button is within reach of all persons involved in running tests.
- Anticipate movements in unintended directions or oscillations of the motor.

Failure to follow these instructions can result in death, serious injury, or equipment damage.

The product can be accessed via different types of access channels. Simultaneous access via multiple access channels or the use of exclusive access may cause unintended equipment operation.

⚠ WARNING

UNINTENDED EQUIPMENT OPERATION

- Verify that simultaneous access via multiple access channels cannot cause unintended triggering or blocking of commands.
- Verify that the use of exclusive access cannot cause unintended triggering or blocking of commands.
- Verify that the required access channels are available.

Failure to follow these instructions can result in death, serious injury, or equipment damage.

Commissioning Tools

Overview

The following tools, page 65 can be used for commissioning, parameterization, and diagnostics:



①



②

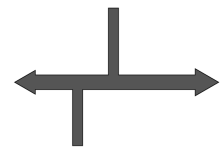

③

Item	Description
1	Integrated HMI
2	PC with commissioning software LXM28 DTM Library
3	Fieldbus

Device settings can be duplicated. Stored device settings can be transferred to a device of the same type. Duplicating the device settings can be used if multiple devices are to have the same settings, for example, when devices are replaced.

Integrated HMI

What's in This Chapter

Overview 138
 Integrated HMI Structure 139
 7-Segment Display 139
 Status Information Via the HMI 141

Overview

The integrated HMI allows you to edit parameters, start the operating mode Jog or perform autotuning via the integrated Human-Machine Interface (HMI). Diagnostics information (such as parameter values or error codes) can also be displayed. The individual sections on commissioning and operation include information on whether a function can be carried out via the integrated HMI or whether the commissioning software must be used.

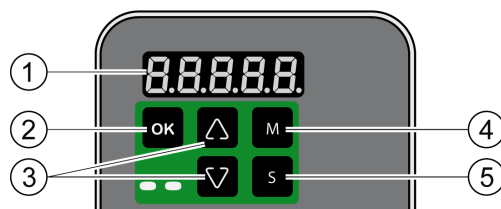

Item	Description
1	5-digit 7-segment display
2	OK key
3	Arrow keys
4	M key
5	S key

Incorrect wiring of the motor connection may cause live wires to be exposed outside of the motor connector below the HMI.

⚡ ⚠ **DANGER**

ELECTRIC SHOCK CAUSED BY INCORRECT WIRING

- Verify that the protective ground connection (PE) of the device is connected to ground.
- Do not remove the cable end (ferrule) from the protective ground terminal (PE) of the motor connector until you are prepared to wire the protective ground conductor of the motor to the protective ground terminal (PE) of the motor connector.
- Verify that no bare metal of the wires is exposed outside of the motor connector housing when wiring the motor connector.
- Regularly, as part of a maintenance plan, assure that the motor wires are secured in the terminals of the motor connector due to vibration or other influences.

Failure to follow these instructions will result in death or serious injury.

Integrated HMI Structure

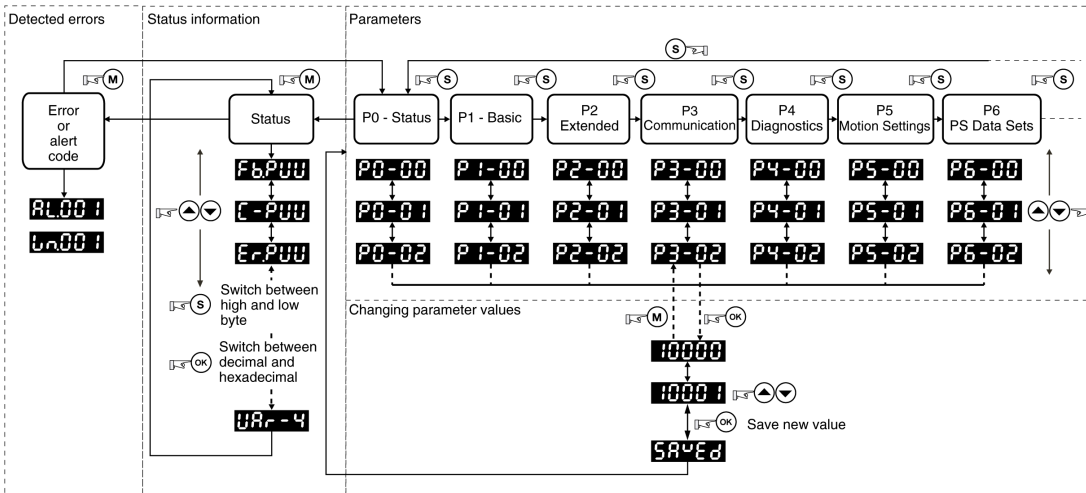

When the drive is powered on, the display shows the name of the selected status information function for approximately one second; after that, it displays the corresponding actual value or status value.

Element	Function
HMI display	The 5-digit 7-segment display shows actual values, parameter settings, status information, and error codes.
M key	The M key lets you switch between the type of information displayed: status information/actual values, error codes, and parameters. If an error is detected, the display shows the error code. If you press the M while the error is active, you can display other information; however, after approximately 20 seconds without interaction, the error code is displayed again.
S key	The S lets you scroll through the parameter groups. After you have selected a parameter and its value is displayed, you can use the S key to move the cursor to the left. The digit at the current cursor position flashes. The arrow keys let you change the value at the current cursor position.
Arrow keys	The arrow keys let you scroll through the actual values/status information and the parameters within a parameter group. Use the arrow keys to increase or decrease values.
OK key	After you have selected a parameter, press the OK key to display the current parameter value. The arrow keys let you change the displayed value. Pressing the OK key again saves the value.

7-Segment Display

Saving Settings

If you set a new parameter value and press the **OK** key, a message is displayed for approximately one second to provide feedback.

7-segment display	Description
5 R u E d	The new parameter value was successfully saved.
r - o L Y	The parameter value is a read-only value and cannot be saved (Read-Only).
P r o t	Changing a parameter value requires exclusive access. See chapter <i>Access Channels</i> , page 223.
o u t - r	The new parameter value is outside the permissible value range (Out of range).

7-segment display	Description
<i>S r v o n</i>	The new parameter value can only be saved when the power stage is disabled (Servo On).
<i>P o - O n</i>	The new parameter value becomes active the next time the product is powered on (Power On).
<i>E r r o r</i>	Displayed whenever a value you have entered for a parameter is, for various reasons, rejected by the drive.

Representation of Numerical Values on the 7-Segment Display

The illustration below shows the decimal representation of a 16-bit value and a 32-bit value as a positive value and as a negative value each.

Example of representation of decimal values

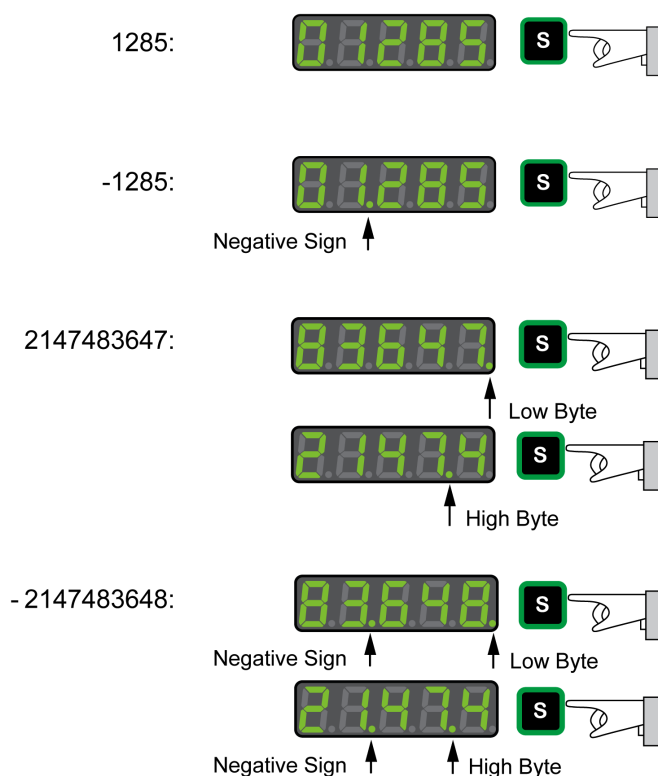

Example of representation of hexadecimal values

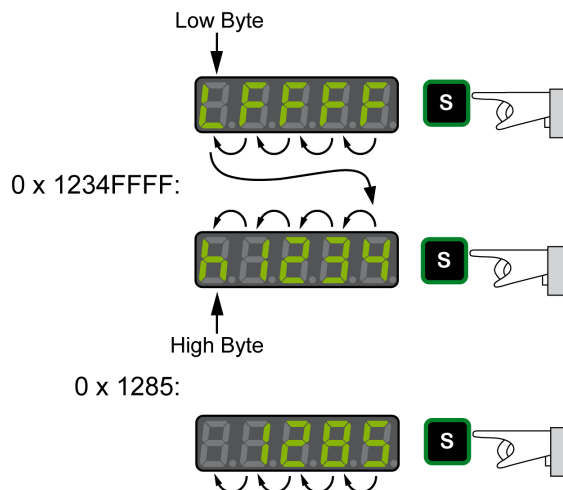

Changing the Sign Via the 7-Segment Display

7-segment display	Description
2 4 6 8 0 2 4 . 6 8 0 X 3 4 3 E X C b C 2	You can change the sign of a value by holding down the S key for a period of more than 2 seconds. Negative decimal values are represented with a dot between the second and the third position. Negative hexadecimal values are represented as a two's complement.

Alert Messages and Error Messages on the 7-Segment Display

7-segment display	Description
W n n n n	If an alert condition is detected, Wnnnn is displayed. Win identifies the code as an alert. The subsequent 3 digit nnn represent the number of the alert. For a list of alert codes, refer to <i>Alert Codes and Error Codes</i> , page 253.
R L n n n	If an error is detected ALnnn is displayed. AL identifies the code as a detected error. The subsequent 3 digit nnn represent the error number. For a list of error codes, refer to <i>Alert Codes and Error Codes</i> , page 253.
S T O P	The display shows STOP if exclusive access is enabled while the power stage is still enabled. For further information on access channels, refer to <i>Access Channels</i> , page 223.
- - - - -	The display shows - - - - - if the drive boot was unsuccessful. It may be caused by corrupted or missing firmware, or because the hardware is inoperable. Contact your local Schneider Electric service representative.

Status Information Via the HMI

After you have powered on the drive, status information is displayed via the HMI. Use the parameter *P0-02* to select the type of status information to be displayed. For example, if you set the parameter *P0-02* to the value 7, the speed of rotation of the motor after is displayed after you have powered on the drive.

Setting <i>P0-02</i>	Description
0	Actual position (with gear ratio applied) in the unit PUU
1	Target position (with gear ratio applied) in the unit PUU
2	Deviation between actual position and target position (with gear ratio applied) in the unit PUU
3	Actual position in motor increments (1280000 pulses/revolution)
4	Target position in motor increments (1280000 pulses/revolution)
5	Deviation between actual position and target position in motor increments (1280000 pulses/revolution)
6	Reference value in kilopulses per second (kpps)
7	Actual velocity in rpm
8	Voltage for target velocity in V
9	Target velocity in rpm
10	Voltage for target torque in V
11	Target torque in percent of continuous motor current
12	Average load of the motor in percent of continuous motor current (The sampling window duration is specified via parameter <i>P4-29</i>)

Setting <i>P0-02</i>	Description
13	Peak load of the motor since the last power cycle of the drive in percent of continuous motor current (maximum value of occurring in setting 12 since last power cycle)
14	Mains voltage in V
15	Ratio of load inertia and motor inertia (divided by 10)
16	Power stage temperature in degrees Celsius (°C)
17	Resonance frequency in Hz
18	Absolute pulse number relative to encoder
19	Mapping parameter 1: Content of parameter <i>P0-25</i> (mapping target is specified via parameter <i>P0-35</i>)
20	Mapping parameter 2: Content of parameter <i>P0-26</i> (mapping target is specified via parameter <i>P0-36</i>)
21	Mapping parameter 3: Content of parameter <i>P0-27</i> (mapping target is specified via parameter <i>P0-37</i>)
22	Mapping parameter 4: Content of parameter <i>P0-28</i> (mapping target is specified via parameter <i>P0-38</i>)
23	Status indication 1: Content of parameter <i>P0-09</i> (the status information to be displayed is specified by parameter <i>P0-17</i>)
24	Status indication 2: Content of parameter <i>P0-10</i> (the status information to be displayed is specified by parameter <i>P0-18</i>)
25	Status indication 3: Content of parameter <i>P0-11</i> (the status information to be displayed is specified by parameter <i>P0-19</i>)
26	Status indication 4: Content of parameter <i>P0-12</i> (the status information to be displayed is specified by parameter <i>P0-20</i>)
27	Reserved
39	Status of digital inputs (content of P4-07)
40	Status of digital outputs (content of P4-09)
41	Drive status (content of P0-46)
42	Operating mode (content of P1-01)
50	Target velocity in rpm
53	Target torque in 0.1 percent of the nominal torque
54	Actual torque in 0.1 percent of the nominal torque
55	Actual torque in 0.01 A
96	Firmware version and firmware revision of drive (<i>P0-00</i> and <i>P5-00</i>)
111	Number of detected errors

Commissioning Procedure

What's in This Chapter

Commissioning Software	143
Setting the Device Address, Baud Rate and Connection Settings.....	143
Verifying the Direction of Movement.....	146
Verifying the Safety Function STO	147

Commissioning Software

The commissioning software LXM28 DTM Library has a graphic user interface and is used for commissioning, diagnostics, and testing settings.

Online Help

The commissioning software offers help functions, which can be accessed via help menu or by pressing the F1 key.

Source of Commissioning Software

The latest version of the commissioning software LXM28 DTM Library is available for download from the Internet.

www.se.com

Setting the Device Address, Baud Rate and Connection Settings

Each device is identified by a unique address. Each device must have its own unique node address, which may only be assigned once in the network. The transmission rate (baud rate) must be the same for all devices in the network.

Use the parameter *P3-00* to set the Modbus device address.

Use the parameter *P3-05* to set the SERCOS III device address.

Use the parameter *P3-08* to set the SERCOS III communication protocol.

Use the parameter *P3-01* to set the Modbus baud rate.

Use the parameter *P3-02* to set the connection settings.

Setting the baud rate:

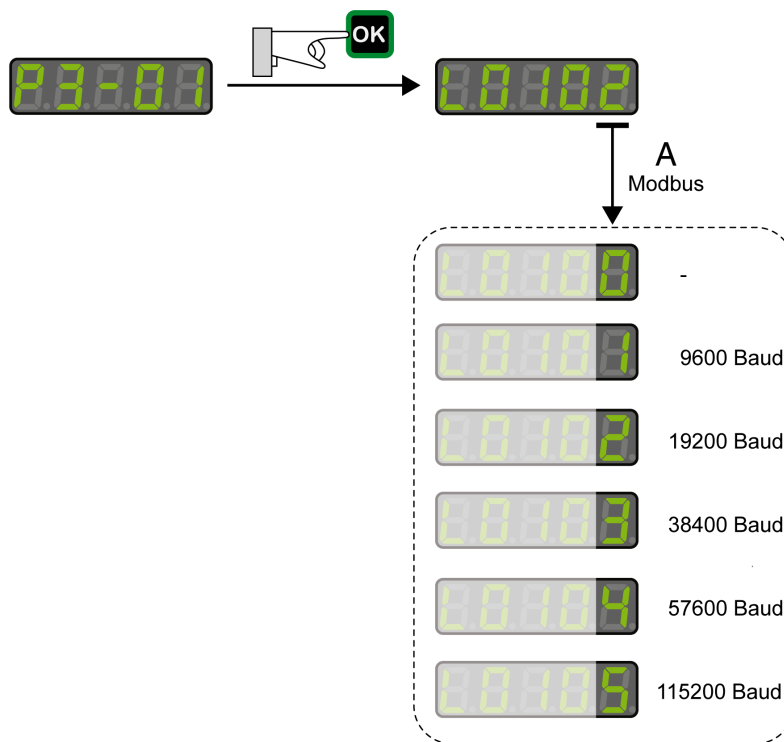

Modbus Connection Settings

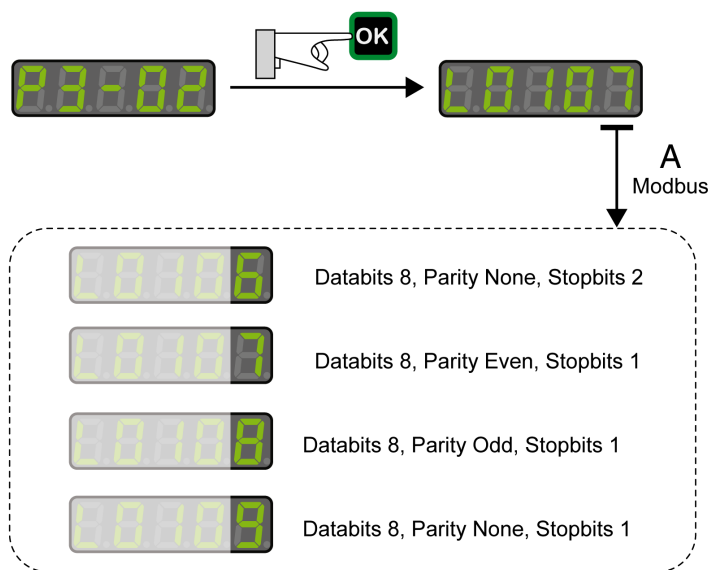

⚠ WARNING

UNINTENDED EQUIPMENT OPERATION

- Verify that there is only one master controller configured on the network or remote link.
- Verify that all devices have unique addresses.
- Confirm that the device address is unique before placing the system into service.

Failure to follow these instructions can result in death, serious injury, or equipment damage.

Parameter name	Description	Unit Minimum value Factory setting Maximum value HMI Format	Data type R/W Persistent	Parameter address via fieldbus
P3-00 ADR	Device Address Modbus The device address must be unique. Modified settings become active the next time the product is powered on.	- 1 127 247 Decimal	u16 RW per.	Modbus 400 _h IDN P-0-3003.0.0
P3-01 BRT	Transmission Rate This parameter is used to set the data transmission rate. Modified settings become active the next time the product is powered on.	- 0 _h 102 _h 405 _h Hexadecimal	u16 RW per.	Modbus 402 _h IDN P-0-3003.0.1
P3-02 PTL	Modbus Connection Settings This parameter specifies the Modbus connection settings. Modified settings become active the next time the product is powered on.	- 6 _h 7 _h 9 _h Hexadecimal	u16 RW per.	Modbus 404 _h IDN P-0-3003.0.2
P3-03 FLT	Detected Modbus Communication Errors - Handling This parameter specifies the response of the drive to a detected communication error. Value 0: Detected alert Value 1: Detected error	- 0 _h 0 _h 1 _h Hexadecimal	u16 RW per.	Modbus 406 _h IDN P-0-3003.0.3
P3-04 CWD	Modbus Connection Monitoring This parameter specifies the maximum permissible duration for communication timeout. When this time has elapsed, the communication timeout is treated as a detected error. Setting this parameter to 0 to disables connection monitoring.	ms 0 0 20000 Decimal	u16 RW per.	Modbus 408 _h IDN P-0-3003.0.4
P3-05 CMM	Device Address SERCOS III This parameter specifies the SERCOS III address of the drive in decimal format. The device address must be unique. Change to this parameter becomes effective only after a restart of the drive. Modified settings become active the next time the product is powered on.	- 0 0 127 Decimal	u16 RW per.	Modbus 40A _h IDN P-0-3003.0.5

Parameter name	Description	Unit Minimum value Factory setting Maximum value HMI Format	Data type R/W Persistent	Parameter address via fieldbus
P3-07 CDT	Modbus Response Delay Time This parameter specifies the time delay with which the drive responds to the Modbus master.	0.5 ms 0 0 1000 Decimal	u16 RW per.	Modbus 40E _n IDN P-0-3003.0.7
P3-08 PROTOCOL	Fieldbus protocol This parameter specifies the active communication protocol. Value 2: SERCOS III protocol selected (M262 compatible) Value 4: SERCOS III protocol selected (LMC078 compatible)	- 2 _h 2 _h 4 _h Hexadecimal	u16 RW per.	Modbus 410 _n IDN P-0-3003.0.8

Verifying the Direction of Movement

Direction of Movement

⚠ WARNING

UNINTENDED MOVEMENT CAUSED BY INTERCHANGED MOTOR PHASES

Do not interchange the motor phases.

Failure to follow these instructions can result in death, serious injury, or equipment damage.

If your application requires an inversion of the direction of movement, you may parameterize the direction of movement.

Movements are made in positive or in negative directions.

Definition of the direction of movement: Positive direction of movement is when the motor shaft rotates counterclockwise as you look at the end of the protruding motor shaft.

Direction of movement with factory settings

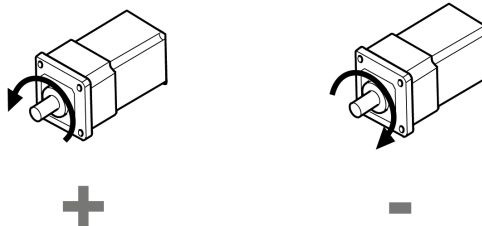

Verifying the Direction of Movement

- Start the operating mode Jog. (HMI: *P 4 - 0 5*)
The HMI displays the velocity in the unit rpm for the operating mode JOG.
- Set a velocity suitable for your application and conform with the OK key.
The HMI displays *J O G*.

Movement in positive direction:

- Press the **Up Arrow** key.
A movement is made in positive direction.

Movement in negative direction:

- Press the **Down Arrow** key.
A movement is made in negative direction.

Press the M key to terminate the operating mode Jog.

Changing the Direction of Movement

If the expected direction of movement and the actual direction of movement are not identical, you can invert the direction of movement.

- Inversion of direction of movement is not activated:
Movements are made in positive direction with positive target values.
- Inversion of direction of movement is activated:
Movements are made in positive direction with negative target values.

The parameter *P1-01 C = 1* allows you to invert the direction of movement.

Changing the direction of movement

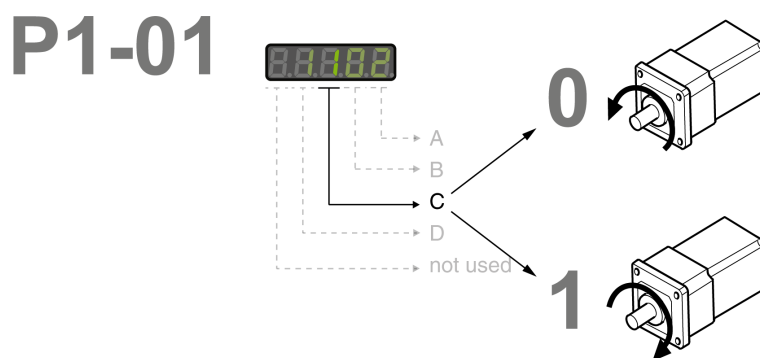

Verifying the Safety Function STO

The safety function STO must be tested at least once per year.

Procedure:

- Operate the system with the nominal voltage at the STO inputs as described in the chapter *Inputs / Outputs Characteristics*, page 36.
- Enable the power stage (operating state 6 Operation Enabled).
- Trigger the safety function STO by switching off the voltage (for example, via an emergency stop push-button).

The power stage is disabled and the error message AL501 is displayed.

- Verify that drive is in the operating state Fault.

- Check whether the drive can be set to the operating state 6 Operation Enabled.

The drive remains in the operating state Fault.

- Restore the STO voltage at the signal inputs of the safety function STO and trigger a Fault Reset.
- Verify that the drive can be set to the operating state 6 Operation Enabled.
The drive is set to the operating state 6 Operation Enabled. Movements are possible again.

Tuning the Control Loops

What's in This Chapter

Tuning the Control Loops	149
Easy Tuning	149
Comfort Tuning	150
Manual Tuning	156

Tuning the Control Loops

Autotuning and manual tuning move the motor in order to tune the control loops. Incorrect parameters may cause unintended movements or the loss of monitoring functions.

▲ WARNING
<p>UNINTENDED MOVEMENT</p> <ul style="list-style-type: none"> • Only start the system if there are no persons or obstructions in the zone of operation. • Verify that the values for the parameters <i>P9-26</i> and <i>P9-27</i> do not exceed the available movement range. • Verify that the parameterized movement ranges are available. • In determining the available movement range, consider the additional distance for the deceleration ramp in the case of an EMERGENCY STOP. • Verify that the parameter settings for a Quick Stop are correct. • Verify correct operation of the limit switches. • Verify that a functioning emergency stop push-button is within reach of all persons involved in the operation. <p>Failure to follow these instructions can result in death, serious injury, or equipment damage.</p>

Autotuning adapts the control performance of the drive to the mechanical system used and optimizes the control loop settings appropriately. External factors such as a load at the motor are considered. The control loop settings can also be optimized by using manual tuning.

Two autotuning methods and manual tuning are provided for control loop optimization:

- **Easy Tuning:** This type of autotuning is performed without user intervention. For most applications, Easy Tuning yields good, highly dynamic results.
- **Comfort Tuning:** This type of autotuning is performed with user intervention. You can select optimization criteria and set parameters for movement, direction, and velocity.
- **Manual Tuning:** This type of tuning allows you to perform test movements and optimize the control loop settings using the Scope function.

Easy Tuning

Easy Tuning is started via the HMI or the commissioning software LXM28 DTM Library.

Easy Tuning requires an available movement range of 5 revolutions. During Easy Tuning, movements of 2.5 revolutions are performed in positive direction of movement and 2.5 revolutions in negative direction of movement. If this movement range is not available, you must use Comfort Tuning.

Easy Tuning can be used for a ratio of motor inertia to load inertia of up to 1:50.

Performing Easy Tuning

Set the parameter P2-32 to 1 to perform Easy Tuning.

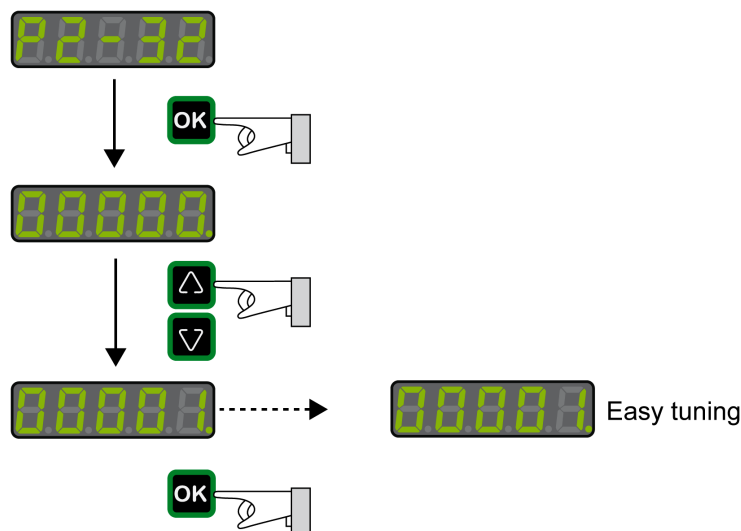

After you have started Easy Tuning via P2-32, the display of the HMI shows the progress as a percentage from `tn000` to `tn100`.

Press the **M** button of the HMI to cancel autotuning.

If autotuning completes successfully, the display of the HMI shows the message `done`.

Press the **OK** key of the HMI to save the control loop parameters. The display of the HMI briefly shows the message `saved`.

Press the **M** key of the HMI to discard the autotuning results.

If autotuning does not complete successfully, the display of the HMI shows the message `ERROR`. The cause can be read with the parameter P9-30.

The parameter P9-37 provides additional information on the last event that occurred during autotuning.

Comfort Tuning

Comfort Tuning allows you to select optimization criteria and set values for the movement.

Optimization Criteria for Comfort Tuning

Comfort Tuning allows you to select an optimization criterion for autotuning. The following optimization criteria are available:

- Optimization of the control loop parameters for minimum settling time with vibration suppression
- Optimization of the control loop parameters for minimum overshoot with vibration suppression
- Optimization of the control loop parameters for minimum settling time without vibration suppression

- Optimization of the control loop parameters for minimum overshoot without vibration suppression

The illustration below shows optimization for minimum overshoot and optimization for minimum settling time.

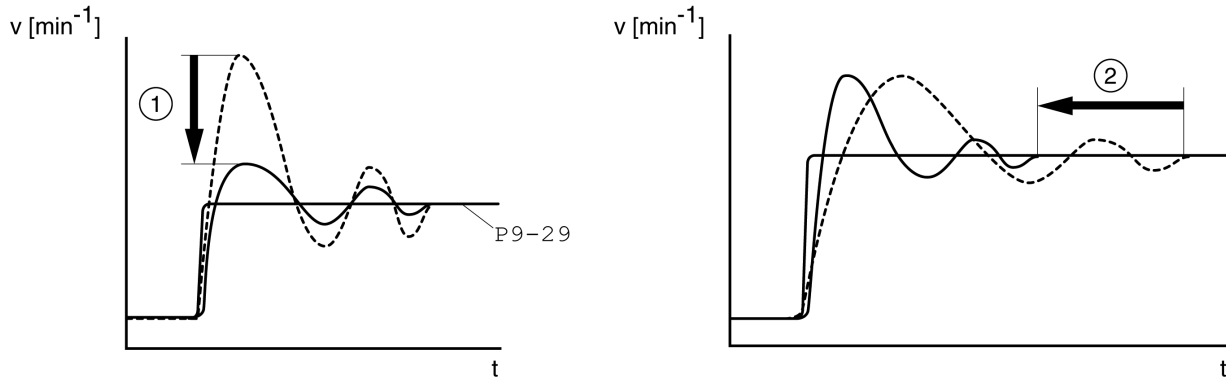

Item	Description
1	Optimization for minimum overshoot
2	Optimization for minimum settling time

Vibration suppression compensates resonance frequencies of the mechanical system. The option Vibration Suppression is available for both optimization criteria.

Parameters for the Movement for Comfort Tuning

The following settings must be made for Comfort Tuning:

- Direction of movement
- Velocity
- Acceleration and deceleration
- Movement range
- Smoothing

These values must be as close as possible to the values used in the actual application. If you enter implausible values, Comfort Tuning is canceled.

Setting the Direction of Movement

Set the direction of movement via the parameter P9-20.

Parameter name	Description	Unit	Data type	Parameter address via fieldbus
		Minimum value	R/W	
		Factory setting	Persistent	
		Maximum value		
		HMI Format		
P9-20	Autotuning - Direction of Movement	-	s16	Modbus A28 _h
LTNCYCLE	This parameter sets the direction of movement for autotuning.	0	RW	P-0-3009.0.20
	Value 0: Both directions of movement	0	-	
	Value 2: One direction of movement	3		
		Decimal		

Setting the Velocity

Set the velocity via the parameter P9-29.

The velocity must be between 10 ... 100 % of the nominal velocity n_N .

Parameter name	Description	Unit Minimum value Factory setting Maximum value HMI Format	Data type R/W Persistent	Parameter address via fieldbus
P9-29 LTNVCRUISE	Autotuning - Velocity Bits 0 ... 15: Velocity for positive direction of movement Bits 16 ... 31: Velocity for negative direction of movement	0.1rpm 0.1rpm - - - Decimal	u32 RW -	Modbus A3A _n P-0-3009.0.29

Setting Acceleration and Deceleration

Set the acceleration and the deceleration with the P9-31 parameter.

The value for the acceleration and the value for the deceleration must be between t_{\min} and t_{\max} :

$$t_{\min} = \frac{100}{90} 20\pi \frac{J_M + J_{\text{load}}}{M_{\max}} \quad t_{\max} = \frac{100}{33} 20\pi \frac{J_M + J_{\text{load}}}{M_N}$$

J_M = Moment of inertia of the motor in kg cm²

J_{load} = Moment of inertia of the load in kg cm²

M_{\max} = Peak torque in Nm

M_N = Nominal torque in Nm

Parameter name	Description	Unit Minimum value Factory setting Maximum value HMI Format	Data type R/W Persistent	Parameter address via fieldbus
P9-31 PTACCDEC	Autotuning - Acceleration and Deceleration Bits 0 ... 15: Acceleration for Autotuning Bits 16 ... 31: Deceleration for Autotuning	ms ms 6 6 6000 6000 65500 65500 Decimal	u32 RW -	Modbus A3E _n P-0-3009.0.31

Setting the Movement Range

Set the movement range via parameters P9-26 and P9-27.

The movement range must be sufficiently large to allow for a constant movement at the set speed in addition to the acceleration phase and the deceleration phase.

Parameter name	Description	Unit Minimum value Factory setting Maximum value HMI Format	Data type R/W Persistent	Parameter address via fieldbus
P9-26 PTPOS	<p>Autotuning - Movement Range in Direction 1</p> <p>This parameter specifies the movement range for autotuning in direction of movement 1.</p> <p>The sign of the value determines the direction of movement:</p> <p>Positive value: Positive direction of movement as set via parameter P1-01</p> <p>Negative value: Negative direction of movement as set via parameter P1-01</p> <p>See parameter P9-20 to select one direction of movement or both directions of movement for Comfort Tuning.</p>	PUU -2147483647 0 2147483647 Decimal	s32 RW -	Modbus A34 _h P-0-3009.0.26
P9-27 PTNEG	<p>Autotuning - Movement Range in Direction 2</p> <p>This parameter specifies the movement range for autotuning in direction of movement 2.</p> <p>The sign of the value determines the direction of movement:</p> <p>Positive value: Positive direction of movement as set via parameter P1-01</p> <p>Negative value: Negative direction of movement as set via parameter P1-01</p> <p>See parameter P9-20 for Comfort Tuning in a single or in both directions of movement.</p> <p>See parameter P9-20 to select one direction of movement or both directions of movement for Comfort Tuning.</p>	PUU -2147483647 0 2147483647 Decimal	s32 RW -	Modbus A36 _h P-0-3009.0.27

Setting Smoothing

Comfort Tuning uses S-curve smoothing by default. The value for smoothing via the S-curve is optimized during Comfort Tunings.

The parameter P9-23 allows you to change from automatic smoothing to manual smoothing.

The following options are available for manual smoothing:

- No smoothing
- Smoothing via low-pass filter with a fixed value
- Smoothing via S-curve with a fixed value

Parameter name	Description	Unit Minimum value Factory setting Maximum value HMI Format	Data type R/W Persistent	Parameter address via fieldbus
P9-23 LTNSTIFF	Defines which values are used for the position command filters. Value 0: Automatic smoothing via S-curve optimization of the value Value 1: Manual smoothing	- 0 0 1 Decimal	u16 RW -	Modbus A2E _h P-0-3009.0.23
P8-34 MOVESMOOTH-MODE	Smoothing Filter for Value 0: No smoothing Value 1: LPF smoothing Value 2: S-curve smoothing Setting can only be modified if power stage is disabled.	- 0 2 2 Decimal	u16 RW per.	Modbus 944 _h P-0-4008.0.34

The illustration below shows the movement during Comfort Tuning if smoothing via the low-pass filter is used:

Comfort Tuning with smoothing via low-pass filter

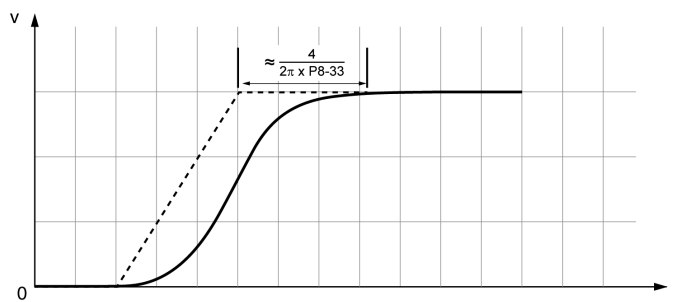

Parameter name	Description	Unit Minimum value Factory setting Maximum value HMI Format	Data type R/W Persistent	Parameter address via fieldbus
P8-33 MOVE-SMOOTHLPFHZ	Low Pass Filter Setting	Hz 1 5000 500000 Decimal	u32 RW per.	Modbus 942 _h P-0-4008.0.33

The illustration below shows the movement during Comfort Tuning if smoothing via an S-curve is used:

Comfort Tuning with smoothing via S-curve

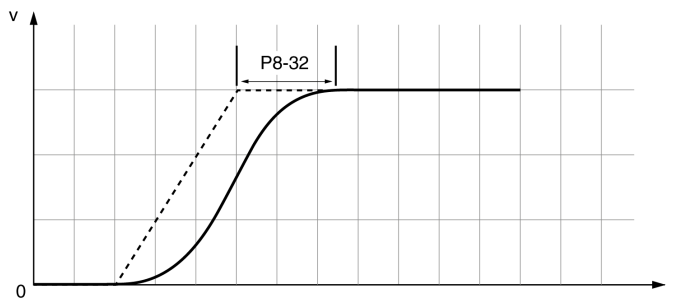

Parameter name	Description	Unit	Data type	Parameter address via fieldbus
		Minimum value	R/W	
		Factory setting	Persistent	
		Maximum value		
		HMI Format		
P8-32	S-Curve Setting	0.01 ms	u32	Modbus 940 _n
MOVESMOOTHAVG	Setting can only be modified if power stage is disabled. The maximum value is reduced to 12800 if P8-35 CONTROLMODE (high byte) is set to 5.	25 400 25600 Decimal	RW per.	P-0-4008.0.32

Performing Comfort Tuning

Start Comfort Tuning by selecting the required method via the parameter P2-32.

Parameter name	Description	Unit	Data type	Parameter address via fieldbus
		Minimum value	R/W	
		Factory setting	Persistent	
		Maximum value		
		HMI Format		
P2-32	Autotuning	-	u16	Modbus 340 _n
ATMODE	This parameter is used to start autotuning with the selected autotuning method. Value 0: Stop Autotuning Value 1: Easy Tuning Value 2: Comfort Tuning [minimum settling time, vibration suppression] Value 3: Comfort Tuning [minimum overshoot, vibration suppression] Value 52: Comfort Tuning [minimum settling time, no vibration suppression] Value 53: Comfort Tuning [minimum overshoot, no vibration suppression]	0 0 56 Decimal	RW -	P-0-4002.0.32

If you want Comfort Tuning in both directions, set parameter P9-20 to 0. Then set the parameters P9-26 and P9-27 to the same values, but with different signs (for example, P9-26 = -20000 and P9-27 = +20000). The value determines the movement range in both directions.

If you want Comfort Tuning in a single direction, set parameter P9-20 to 2. Then set the parameters P9-26 and P9-27 to the same values. The sign of the value

determines the direction for Comfort Tuning. For example, if you set P9-26 = -20000 and P9-27 = -20000, Comfort Tuning is performed in negative direction of movement with a movement range of 20000 PUJ.

NOTE: If you do not enter consistent values for parameters P9-26 and P9-27, the autotuning is unsuccessful. Parameter P9-30 contains the information on the unsuccessful autotuning attempt.

After you have started the required Comfort Tuning method via P2-32, the display of the HMI shows the progress as a percentage from *E n 0 0 0* to *E n 1 0 0*.

Press the **M** button of the HMI to cancel autotuning.

If autotuning completes successfully, the display of the HMI shows the message *d o n E*.

Press the **OK** key of the HMI to save the control loop parameters. The display of the HMI briefly shows the message *S R V E d*.

Press the **M** key of the HMI to discard the autotuning results.

If autotuning does not complete successfully, the display of the HMI shows the message *E r r o r*. The cause can be read with the parameter P9-30.

The parameter P9-37 provides additional information on the last event that occurred during autotuning.

Manual Tuning

Manual tuning is performed in the operating mode Internal Profile. Manual tuning allows you to perform test movements and optimize the control loop settings using the Scope function.

NOTE: Manual tuning should only be attempted by trained persons who are familiar with and understand the contents of this manual and all other pertinent product documentation. These persons must have sufficient technical training, knowledge, and experience and be able to foresee and detect potential hazards and issues that may be caused by manual tuning, by changing the settings and by the mechanical, electrical, and electronic equipment of the entire system in which the product is used. No responsibility is assumed by Schneider Electric for any consequences arising out of the use of manual tuning.

In addition to the low-pass filter, electronic gear filter function can be used in the following cases:

- Pulse and direction command has a low resolution
- Low rigidity of the coupling between motor and load
- Movement is too short
- Motor is noisy after tuning
- Current is unstable during tuning
- Motor temperature is unusually high

Procedure for Manual Tuning

The control loop parameters are tuned in the following sequence:

Step	Item	Parameters
1	Derivative gain, page 157	P8-00 (LTND)
2	Low-pass filter, page 158	P8-14 (NLFILTDAMPING) P8-15 (NLFILTT1)
3	Retuning of the derivative gain, page 161	P8-00 (LTND)

Step	Item	Parameters
4	Proportional gain, page 161	<i>P8-03</i> (LTNP)
5	Derivative-integral gain, page 163	<i>P8-02</i> (LTNIV)
6	Integral gain, page 165	<i>P8-01</i> (LTNI)
7	Compensation of the flexibility of the mechanical system, page 166	<i>P8-05</i> (NLAFFLPFHZ) <i>P8-20</i> (NLPEAFF)

Step 1: Setting the Derivative Gain

The objective of tuning the derivative gain is to achieve a current ripple that is as low as possible. The optimum value primarily depends on the load.

Criteria for a well-tuned derivative gain include:

- For loads less than twice the rotor inertia: 5 % of the nominal current may be acceptable
- For greater loads: 10 % of the nominal current may be acceptable

The derivative gain is set via parameter *P8-00* (LTND).

Procedure:

- Set the value of parameter *P8-03* (LTNP) to 150 (corresponds to 15 Hz).
- Set the value of parameter *P8-01* (LTNI) to 0.
- Set the value of parameter *P8-02* (LTNIV) to 0.
- Progressively increase the value of parameter *P8-00* (LTND) until the oscilloscope shows oscillation of the reference current, *P11-11* (TCMD).

Example *P8-00* (LTND) set to 1340 (134 Hz)

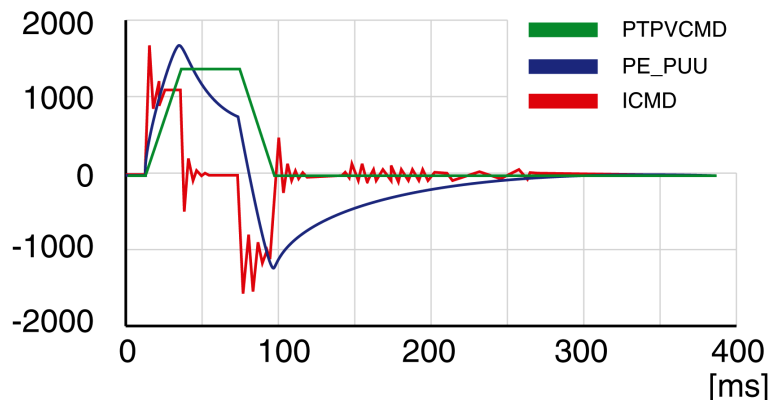

Example *P8-00* (LTND) set too high at 2000 (200 Hz)

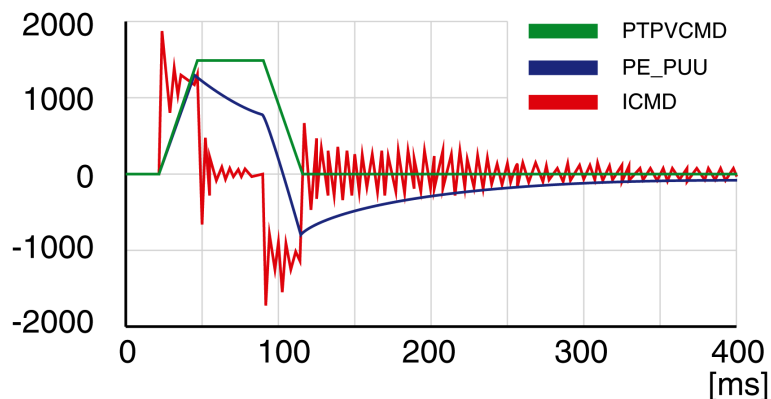

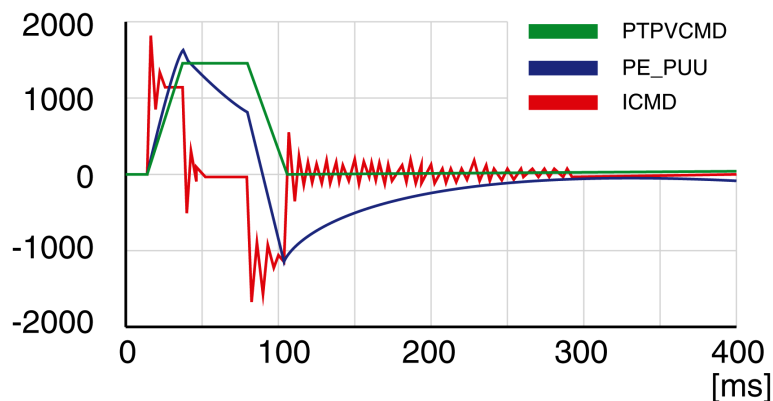
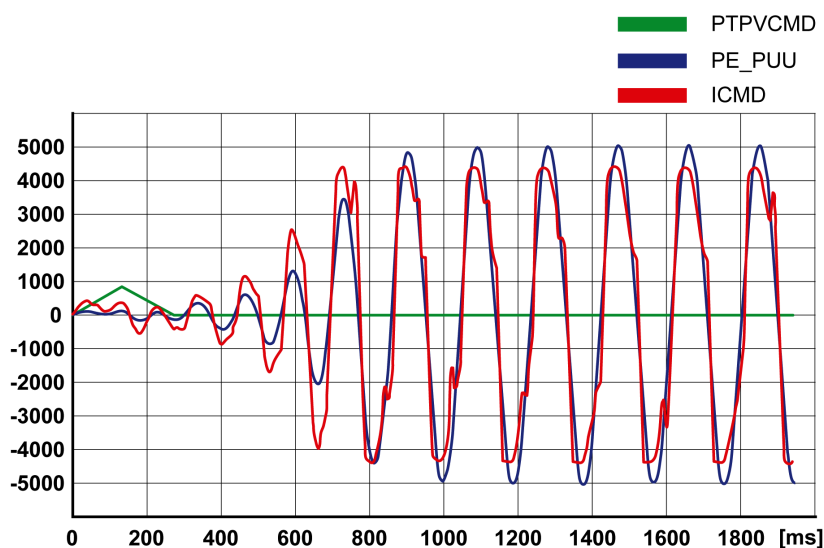
Example *P8-00* (LTND) OK at 1500 (150 Hz)Example *P8-00* (LTND) set too low at 100 (10 Hz)

NOTE: The process of tuning requires trials of successive approximations. Values that are too high or too low relative to the other relevant values might cause instability. If it is necessary to have a low or high value of the parameter in the preceding example, you may need to adjust the values of the other relevant parameters to compensate and achieve a stable system.

Step 2: Setting the Low-Pass Filter

Setting the low-pass filter is an optional step in manual tuning of the control loop parameters. The low-pass filter parameters are optimized after you have tuned the derivative gain. The objective of tuning the low-pass filter parameters is to suppress high-frequency resonance and reduce the response time of the control loops to a minimum.

The low-pass filter is set via parameters *P8-14* (NLFILTDAMPING) and *P8-15* (NLFILTT1).

The parameter *P8-14* (NLFILTDAMPING) maintains the bandwidth of the low-pass filter up to the cutoff frequency. The parameter value is expressed as a percentage. The parameter *P8-15* (NLFILTT1) sets the inverse frequency of the cutoff frequency. The parameter *P8-14* (NLFILTDAMPING) can also be used independently to allow for a certain degree of compensation of system-related bandwidth limits.

Criteria for a well-tuned low-pass filter include:

- The value of parameter *P8-14* (NLFILTDAMPING) is as high as possible.

- The value of parameter *P8-15* (NLFILTT1) is as low as possible.

When *P8-35* (CONTROLMODE) (high byte) is set to 5, the following table presents the values for 10 % overshoot. Set the filter parameter values *P8-14* (NLFILTDAMPING) and *P8-15* (NLFILTT1) accordingly:

Frequency (Hz)	<i>P8-14</i> (NLFILTDAMPING) (%)	<i>P8-15</i> (NLFILTT1) (ms)
100	98.27	122.86
200	29.3	96.5
300	14.3	95
400	7.9	93.32
500	5.05	91.677
600	3.5	90.03
700	2.566	88.4
800	2	86.934
900	1.6056	85.457
1000	1.31	83.98
1100	1.09	82.45
1200	0.928694	81.1
1300	0.815	79.9
1400	0.7	78.4
1500	0.62	77
1600	0.555	75.97
1700	0.496	74.6
1800	0.439	73
1900	0.406	72.19
2000	0.365	70.5

Electronic gear filter example 1:

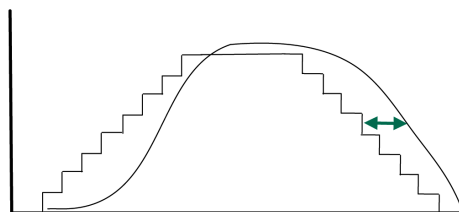

Increasing *P8-27* (GEARFILTT1) smooths the input command, but adds a delay.

Electronic gear filter example 2:

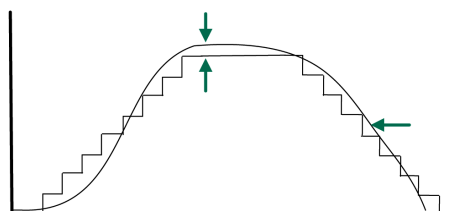

Increasing *P8-28* (GEARFILTT2) and *P8-29* (GEARFILTVELFF) compensate the delay, but adds overshoots.

If *P8-29* (GEARFILTVELFF) has the same value as *P8-28* (GEARFILTT2), there is no delay.

Usual values:

- *P8-27* (GEARFILTT1) is usually around 2 times the input step width
- *P8-28* (GEARFILTT2) is usually 2 times *P8-27* (GEARFILTT1)

NOTE: When a system has multiple axes, gear filter values must be the same for all axes.

Procedure:

- Progressively increase the value of parameter *P8-14* (NLFILTDAMPING) until the oscilloscope shows noise and/or oscillation of the reference current, *P11-11* (TCMD).
- Progressively decrease the value of parameter *P8-15* (NLFILTT1) until the oscilloscope shows noise and/or oscillation of the reference current *P11-11* (TCMD).
- Increase the value of parameter *P8-15* (NLFILTT1) by 20 %, however, by at least 0.05 ms.

Example *P8-14* (NLFILTDAMPING) OK (75 %)

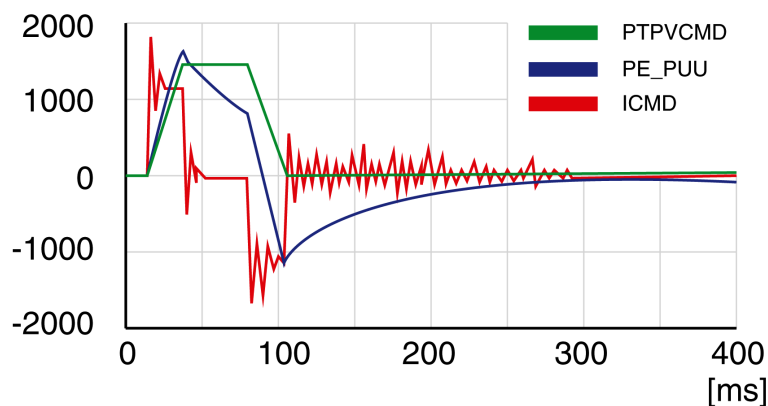

Example *P8-15* (NLFILTT1) too low (0.5 ms)

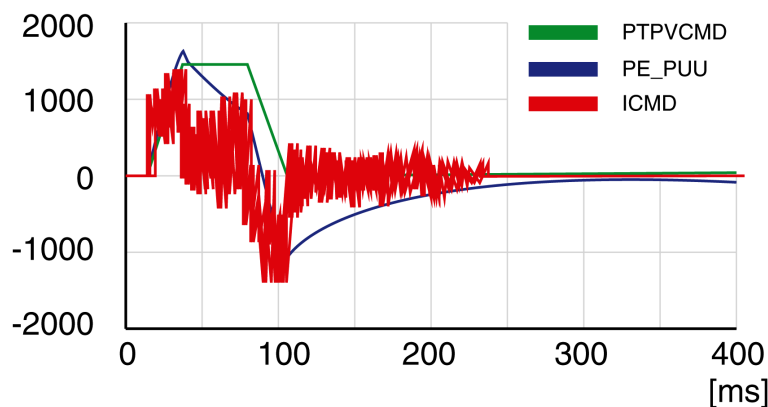

Example *P8-15* (NLFILTT1) OK (1.2 ms)

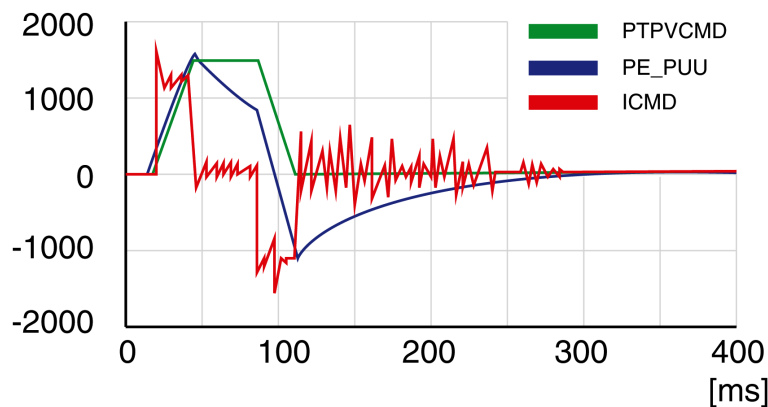

Step 3: Re-Tuning of the Derivative Gain

If you have modified the low-pass filter values in parameters *P8-14* (NLFILTDAMPING) and *P8-15* (NLFILTT1), the derivative gain can be set to a greater value via parameter *P8-00* (LTND). Follow the procedure described in step 1.

The objective of tuning the proportional gain is to get a constant and low position deviation in the acceleration phase, the constant velocity phase, and the deceleration phase and to have no oscillations during the transitions between these phases. In the oscilloscope, this is indicated by a shape that is as square and as flat as possible.

Criteria for a well-tuned proportional gain include:

- No or minimum overshoot of position deviation
- No or minimum current ripple
- No or minimum oscillations at standstill

Step 4: Setting the Proportional Gain

The proportional gain is set via parameter *P8-03* (LTNP).

Procedure:

- Progressively increase the value of parameter *P8-03* (LTNP) to find the optimum value. The figures below show examples of the plot as the value approaches the optimum value.

Example *P8-03* (LTNP) starting value (13 Hz)

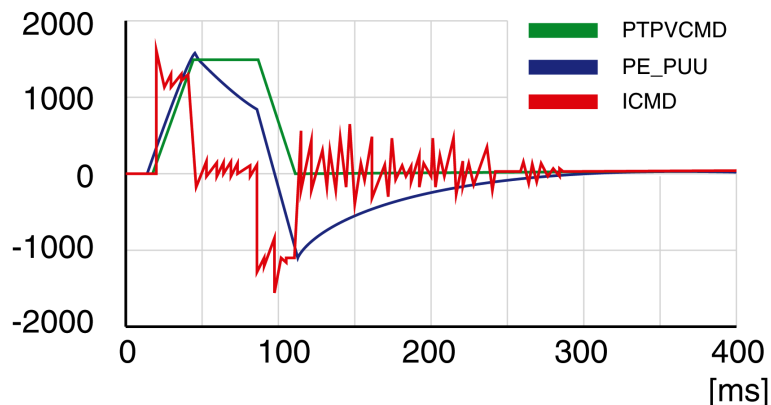

Example *P8-03* (LTNP) position deviation decreased (25 Hz)

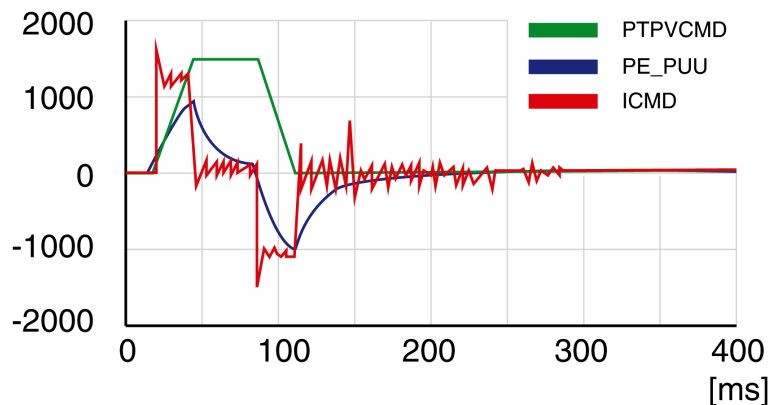

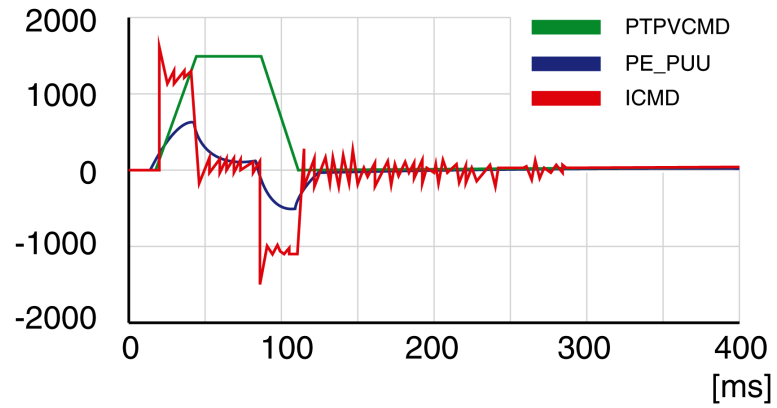
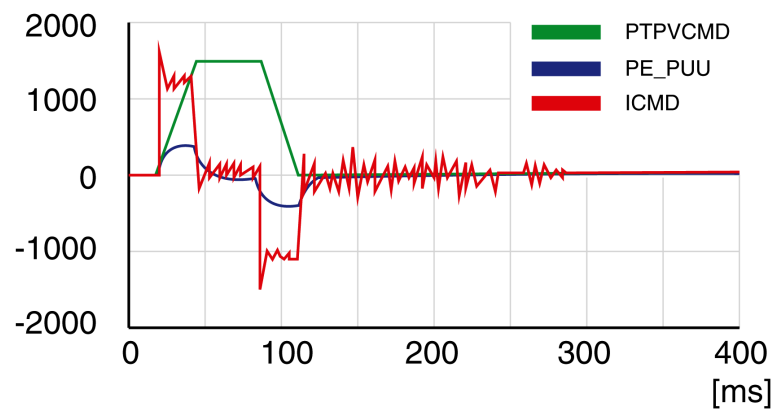
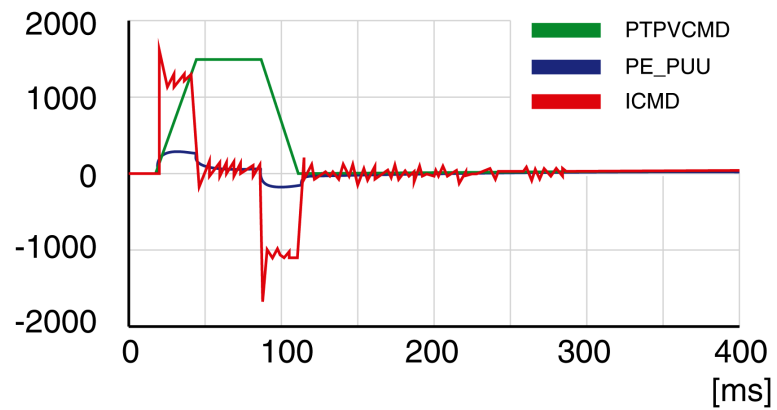
Example *P8-03* (LTNP) position deviation further decreased (35 Hz)Example *P8-03* (LTNP) position deviation further decreased (45 Hz)Example *P8-03* (LTNP) value too high - oscillation at standstill (65 Hz)

Example *P8-03* (LTNP) value too high - oscillation at standstill (75 Hz)

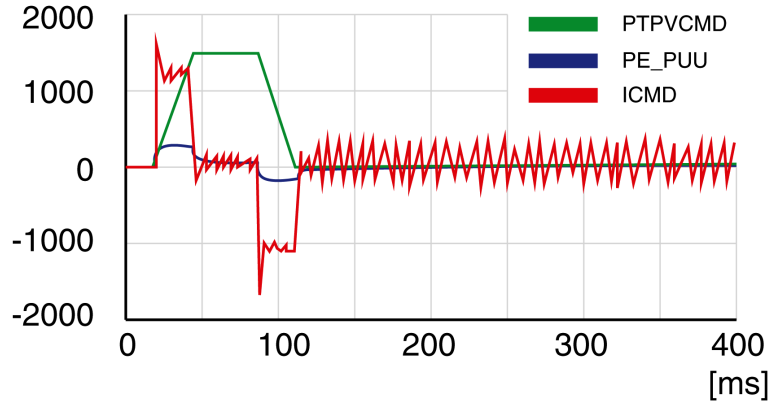

Example *P8-03* (LTNP) value too high - oscillation at standstill, overshoot of position deviation (100 Hz)

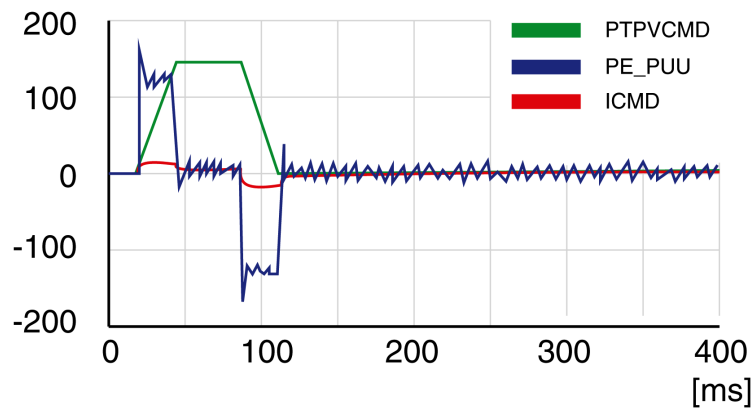

Example *P8-03* (LTNP) OK (65 Hz)

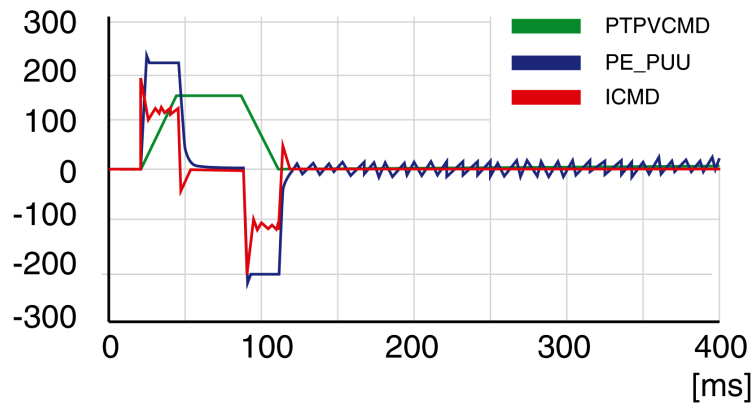

Step 5: Setting the Derivative-Integral Gain

The objective of tuning the derivative-integral gain is to reduce the position deviation. As a general rule, the value for the derivative-integral gain (*P8-02LTNIV*) is within the following range:

$$P8-03 (LTNP) / 2 < P8-02 (LTNIV) < 2 \times P8-03 (LTNP)$$

Progressively increasing the value of the derivative-integral gain progressively decreases the position deviation during the acceleration phase, the constant velocity phase, and the deceleration phase.

Criteria for a well-tuned derivative-integral gain include:

- Position deviation decreases rapidly after each transition of the movement phases (jerk)
- No or minimum overshoot of position deviation
- No or minimum oscillations during transitions between the movement phases
- Oscillations at standstill as low as possible (+/- 1 encoder increment)

The derivative-integral gain is set via parameter *P8-02* (LTNIV).

Procedure:

- Progressively increase the value of parameter *P8-02* (LTNIV) to find the optimum value. The figures below show examples of the plot as the value approaches the optimum value.

Example *P8-02* (LTNIV) starting value (30 Hz)

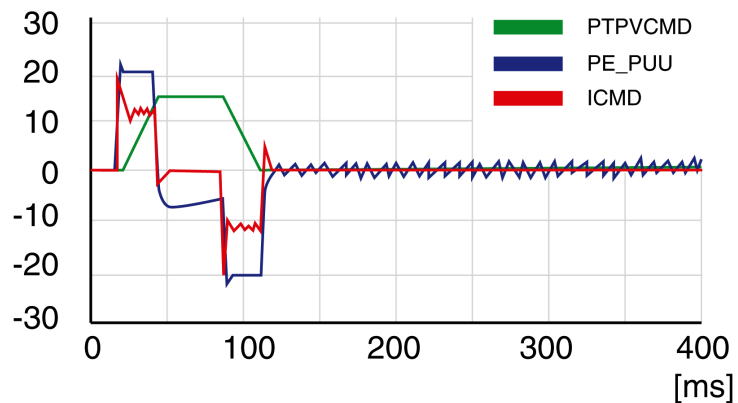

Example *P8-02* (LTNIV) position deviation decreased (60 Hz)

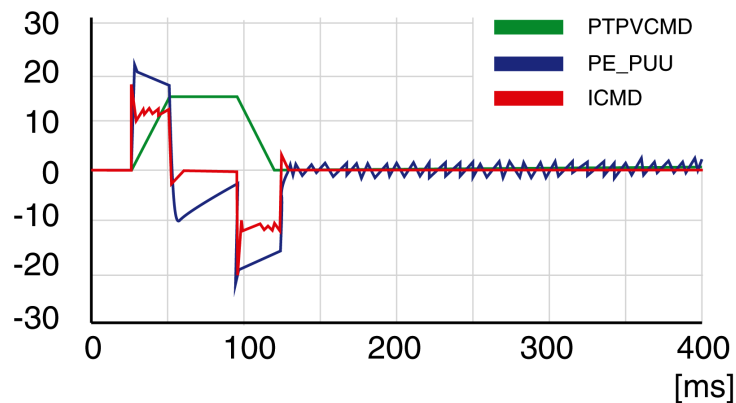

Example *P8-02* (LTNIV) position deviation decreases rapidly when target velocity is reached (90 Hz)

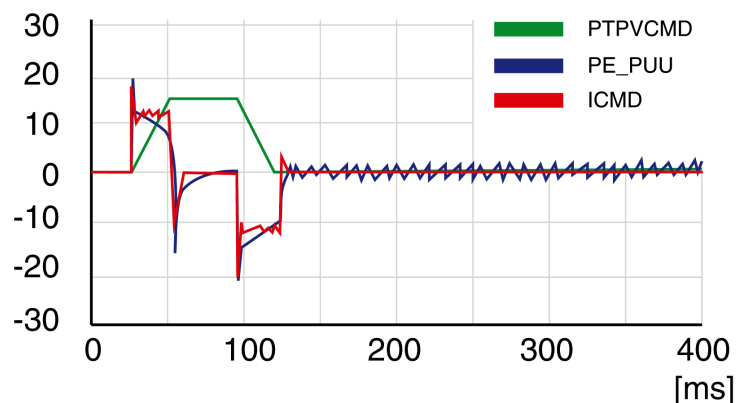

Example *P8-02* (LTNIV) value too high - oscillation at standstill, overshoot of position deviation (120 Hz)

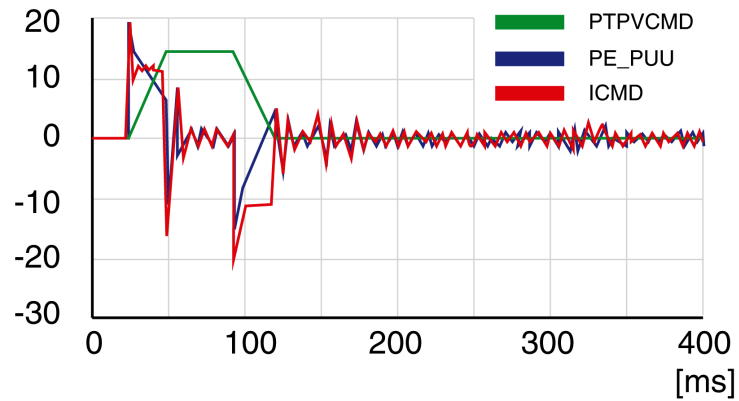

Example *P8-02* (LTNIV) OK (90 Hz)

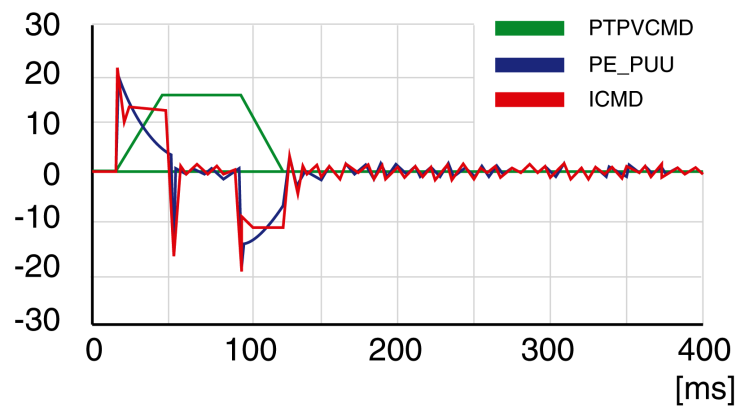

Step 6: Setting the Integral Gain

The objective of tuning the integral gain is to reduce the position deviation during movements and at standstill.

Criteria for a well-tuned integral gain include:

- Position deviation further reduced
- No or minimum overshoot of position deviation at the end of the deceleration phase
- Oscillations at standstill as low as possible (+/- 1 encoder increment)

The integral gain is set via parameter *P8-01* (LTNI).

Procedure:

- Progressively increase the value of parameter *P8-01* (LTNI) until the oscilloscope shows overshoot or oscillations. The figures below show examples of the plot as the value approaches the optimum value.

Example *P8-01* (LTNI) value too high - oscillation at standstill, overshoot of position deviation (50 Hz)

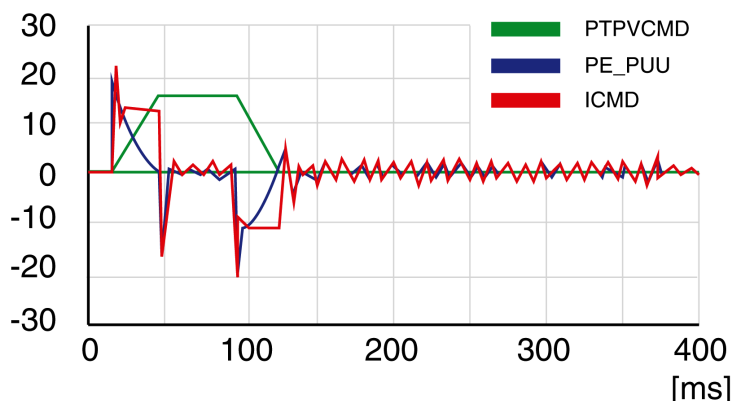

Example *P8-01* (LTNI) OK (25 Hz)

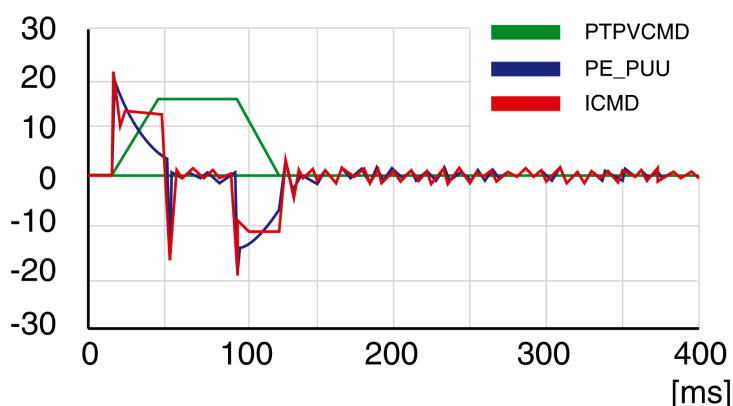

Step 7: Compensation of the Flexibility of the Mechanical System

The parameters for compensation of the system flexibility reduce the vibrations caused by abrupt changes in the acceleration (jerk). The parameters can also be used to further minimize overshoot or settling time.

The value of parameter *P8-20* (NLPEAFF) reflects the oscillation frequency of the mechanical system, i.e. the coupling between the motor and the load. The coupling can be very rigid (for example, a direct drive or a low-backlash coupling) and less rigid (for example, a belt drive or an elastic coupling). Systems with a high rigidity require a high value. Systems with high load inertia and less rigid couplings require lower values. The less rigid the coupling, the lower this frequency. Depending on the application, the typical value range is 400 ... 30 Hz.

The parameter *P8-05* (NLAFFLPFHZ) sets a low-pass filter for the acceleration profile. If the target value has a relatively low resolution, the calculated acceleration may be subject to noise. The low-pass filter set via this parameter can be used to smooth the acceleration profile. The parameter can be used if the flexibility compensation set via parameter *P8-20* (NLPEAFF) results in noise.

The compensation of the flexibility of the mechanical system is set via parameters *P8-05* (NLAFFLPFHZ) and *P8-20* (NLPEAFF).

Procedure:

- Set the value of parameter *P8-05* (NLAFFLPFHZ) to a value three times as high as that of parameter *P8-20* (NLPEAFF). With this value, the bandwidth of this low-pass filter is sufficiently higher than the response time of the system.

- Progressively decrease the value of parameter $P8-20$ (NLPEAFF) to find the optimum value. The optimum value depends on your optimization criterion: either short settling time or low position deviation.

Start with a high frequency of 400 Hz. Decrease the value and compare the amplitudes for the position deviation and the settling time. Select the most suitable value according to your optimization criterion. The figures below show examples of the plot as the value approaches the optimum value.

Example $P8-20$ (NLPEAFF) without compensation of the flexibility (5000 Hz)

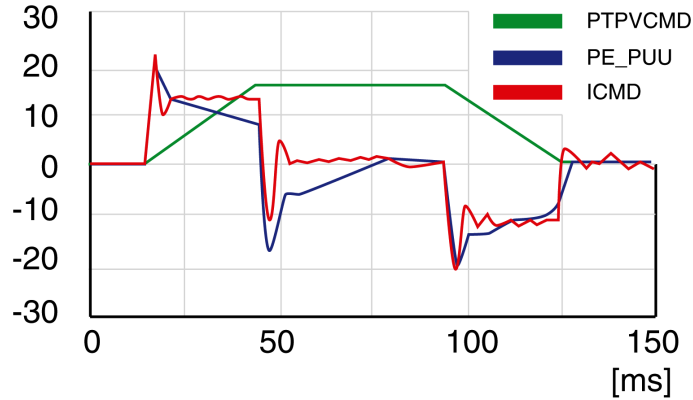

Example $P8-20$ (NLPEAFF) maximum position deviation decreased (300 Hz)

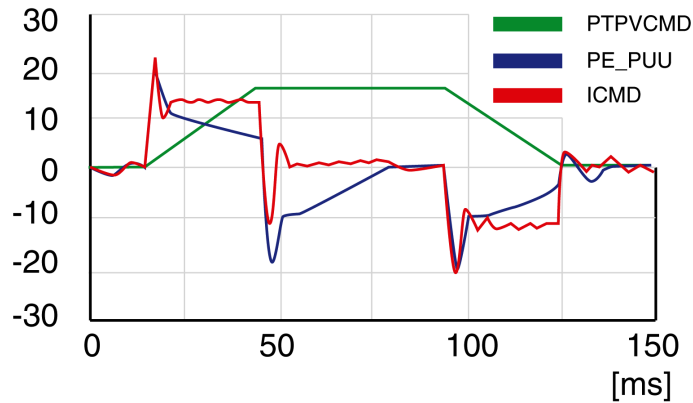

Example $P8-20$ (NLPEAFF) maximum position deviation further decreased (220 Hz)

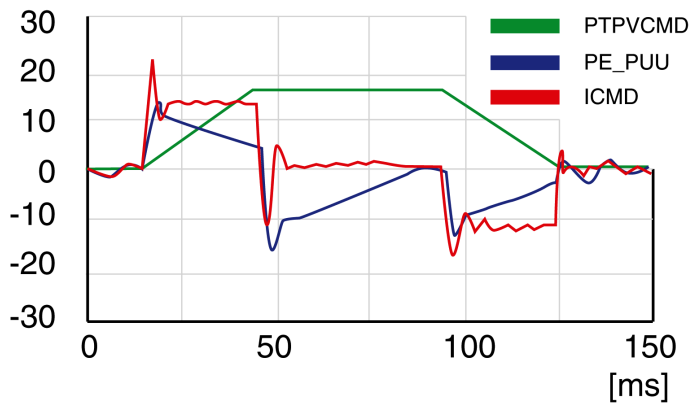

Example P8-20 (NLPEAFF) minimum position deviation, short settling time, oscillation at standstill (120 Hz)

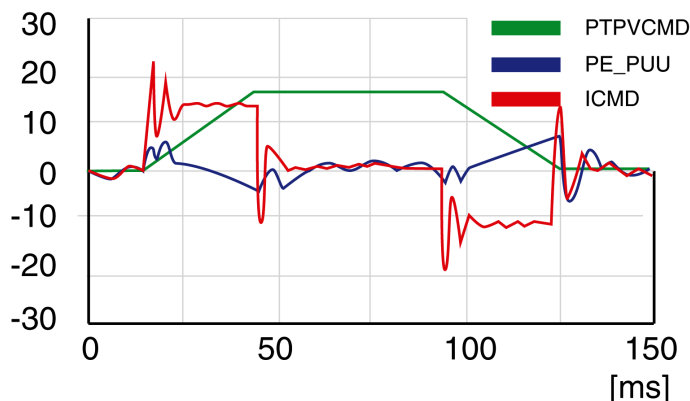

Example P8-20 (NLPEAFF) negative position deviation during acceleration phase (100 Hz)

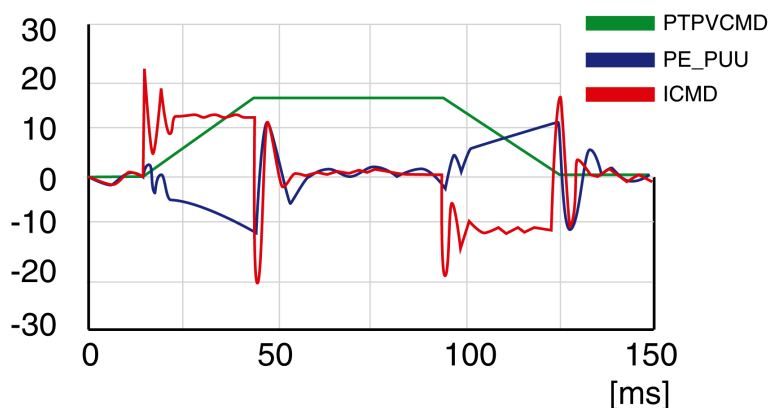

Manual Turning Steps within Cascade Mode

Step	Action
1	Increase the speed loop gain P8-57 to decrease the speed deviation. After increasing the gain value each time, the motor moves in a positive and negative direction at high and low speed respectively. If the motor does not vibrate or scream, the gain can be increased continuously. If the motor vibrates or screams, reduce the current value by 20%.
2	Increase the gain of position loop P8-53 to decrease the position deviation. After increasing the gain value each time, the motor moves in a positive and negative direction at high and low speed respectively. If the motor does not vibrate or scream, the gain can be increased continuously. Slow motor positioning, increase the gain, motor positioning back and forth, reduce the gain. If the motor vibrates or screams, reduce the current value by 20%.
3	To further reduce the steady-state error, increase the speed integral P8-58.
4	To further reduce the dynamic position error, feed-forward P8-54 is used.
5	Set the S-curve smoothing time constant P8-32 appropriately.
6	Use low-pass filtering and notch filter P8-60, P8-61, P8-62 as appropriate.

Parameters

What's in This Part

Parameters.....	170
-----------------	-----

Parameters

What's in This Chapter

Representation of the Parameters	170
P0 - Status Parameters	171
P1 - Basic Parameters	177
P2 - Extended Parameters	186
P3 - Communication Parameters	193
P4 - Diagnostics Parameters	196
P5 - Motion Settings	199
P8 - Control Loops	205
P9 - DTM Data	215

Representation of the Parameters

This chapter provides an overview of the parameters which can be used for operating the product.

Unsuitable settings or unsuitable data may trigger unintended movements, trigger signals, damage parts and disable monitoring functions. Some parameters and other operational data do not become active until after a restart.

▲ WARNING

UNINTENDED EQUIPMENT OPERATION

- Only start the system if there are no persons or obstructions in the zone of operation.
- Do not operate the drive system with undetermined parameter values.
- Never modify a parameter value unless you fully understand the parameter and all effects of the modification.
- Restart the drive and verify the saved operational data and/or parameter values after modification.
- Carefully run tests for all operating states and potential error situations when commissioning, upgrading or otherwise modifying the operation of the drive.
- Verify the functions after replacing the product and also after making modifications to the parameter values and/or other operational data.

Failure to follow these instructions can result in death, serious injury, or equipment damage.

NOTE: Possible values of a parameter that are not described are considered as reserved and must not be used.

Parameter Name

The parameter name uniquely identifies a parameter.

Unit

The unit of the value.

P0 - Status Parameters

P0 - Status Parameters

Parameter name	Description	Unit Minimum value Factory setting Maximum value HMI Format	Data type R/W Persistent	Parameter address via fieldbus
P0-00 VER	Firmware Version	- 0 _h 0 _h FFFF _h Hexadecimal	u16 RO -	Modbus 100 _h IDN P-0-3000.0.0
P0-01 ALE	Error code of detected error This parameter contains the error number of the most recently detected error. For a list of the detected error codes, refer to Error Codes, page 253.	- 0 _h 0 _h FFFF _h Hexadecimal	u16 RW -	Modbus 102 _h IDN P-0-3000.0.1
P0-02 STS	Drive Status Displayed by HMI This parameter selects the type of status information to be displayed on the HMI. Example: If the setting is 7, the HMI displays the speed of rotation of the motor. For further information, refer to chapter Status Information via the HMI, page 141.	- 0 0 123 Decimal	u16 RW per.	Modbus 104 _h IDN P-0-3000.0.2
P0-04 FPGAVER	FPGA Version	- 0 _h - _h 0000FFFF _h Hexadecimal	u16 RO -	Modbus 108 _h IDN P-0-3000.0.4
P0-08 TSON	Operating Hour Meter in Seconds	s 0 - 4294967295 Decimal	u32 RO -	Modbus 110 _h IDN P-0-3000.0.8
P0-09 CM1	Status Value 1 This parameter is used to provide the value of one of the status indications in P0-02. The value of this parameter is determined via P0-17. Examples: If the status of the drive is read via the HMI and if P0-02 is set to 23, VAR-1 is displayed for approximately two seconds by the HMI, followed by the value of this parameter. If the setting of P0-17 is 3, reading this parameter displays the actual position in pulses. For reading the status via Modbus, read two 16-bit data stored in the addresses of 0012H and 0013H to generate 32-bit data.	- -2147483647 - 2147483647 Decimal	s32 RO -	Modbus 112 _h IDN P-0-3000.0.9

Parameter name	Description	Unit Minimum value Factory setting Maximum value HMI Format	Data type R/W Persistent	Parameter address via fieldbus
	(0013H : 0012H) = (high byte : low byte)			
P0-10 CM2	Status Value 2 This parameter is used to provide the value of one of the status indications in P0-02. The value of this parameter is determined via P0-18. See P0-09 for details.	- -2147483647 - 2147483647 Decimal	s32 RO -	Modbus 114 _h IDN P-0-3000.0.10
P0-11 CM3	Status Value 3 This parameter is used to provide the value of one of the status indications in P0-02. The value of this parameter is determined via P0-19. See P0-09 for details.	- -2147483647 - 2147483647 Decimal	s32 RO -	Modbus 116 _h IDN P-0-3000.0.11
P0-12 CM4	Status Value 4 This parameter is used to provide the value of one of the status indications in P0-02. The value of this parameter is determined via P0-20. See P0-09 for details.	- -2147483647 - 2147483647 Decimal	s32 RO -	Modbus 118 _h IDN P-0-3000.0.12
P0-13 CM5	Status Value 5 This parameter is used to provide the value of one of the status indications in P0-02. The value of this parameter is determined via P0-21. See P0-09 for details.	- -2147483647 - 2147483647 Decimal	s32 RO -	Modbus 11A _h IDN P-0-3000.0.13
P0-17 CMA1	Indicate status value 1 This parameter is used to select a drive status provided in P0-02. The selected status is indicated via P0-09. Example: If the setting of P0-17 is 7, reading P0-09 returns the speed of rotation of the motor in rpm.	- 0 0 123 Decimal	u16 RW per.	Modbus 122 _h IDN P-0-3000.0.17
P0-18 CMA2	Indicate status value 2 This parameter is used to select a drive status provided in P0-02. The selected status is indicated via P0-10. See P0-17 for details.	- 0 0 123 Decimal	u16 RW per.	Modbus 124 _h IDN P-0-3000.0.18
P0-19 CMA3	Indicate status value 3 This parameter is used to select a drive status provided in P0-02. The selected status is indicated via P0-11. See P0-17 for details.	- 0 0 123 Decimal	u16 RW per.	Modbus 126 _h IDN P-0-3000.0.19
P0-20 CMA4	Indicate status value 4 This parameter is used to select a drive status provided in P0-02. The selected status is indicated via P0-12. See P0-17 for details.	- 0 0	u16 RW per.	Modbus 128 _h IDN P-0-3000.0.20

Parameter name	Description	Unit Minimum value Factory setting Maximum value HMI Format	Data type R/W Persistent	Parameter address via fieldbus
		123 Decimal		
P0-21 CMA5	Indicate status value 5 This parameter is used to select a drive status provided in P0-02. The selected status is indicated via P0-13. See P0-17 for details.	- 0 0 123 Decimal	u16 RW per.	Modbus 12A _h IDN P-0-3000.0.21
P0-25 MAP1	Parameter Mapping 1 The parameters from P0-25 ... P0-32 are used to read and write the values of parameters with non-consecutive communication addresses. You can set P0-35 ... P0-42 as the required read and write mapping parameter numbers. When P0-25 ... P0-32 are read, the read or write values are equivalent to the values of the parameters specified via P0-35 ... P0-42, and vice versa. See P0-35 for details.	- 0 _h 0 _h FFFFFFFF _h Hexadecimal	u32 RW -	Modbus 132 _h IDN P-0-3000.0.25
P0-26 MAP2	Parameter Mapping 2 See P0-25 and P0-36 for details.	- 0 _h 0 _h FFFFFFFF _h Hexadecimal	u32 RW -	Modbus 134 _h IDN P-0-3000.0.26
P0-27 MAP3	Parameter Mapping 3 See P0-25 and P0-37 for details.	- 0 _h 0 _h FFFFFFFF _h Hexadecimal	u32 RW -	Modbus 136 _h IDN P-0-3000.0.27
P0-28 MAP4	Parameter Mapping 4 See P0-25 and P0-38 for details.	- 0 _h 0 _h FFFFFFFF _h Hexadecimal	u32 RW -	Modbus 138 _h IDN P-0-3000.0.28
P0-29 MAP5	Parameter Mapping 5 See P0-25 and P0-39 for details.	- 0 _h 0 _h FFFFFFFF _h Hexadecimal	u32 RW -	Modbus 13A _h IDN P-0-3000.0.29
P0-30 MAP6	Parameter Mapping 6 See P0-25 and P0-40 for details.	- 0 _h 0 _h FFFFFFFF _h Hexadecimal	u32 RW -	Modbus 13C _h IDN P-0-3000.0.30
P0-31 MAP7	Parameter Mapping 7 See P0-25 and P0-41 for details.	- 0 _h	u32 RW	Modbus 13E _h IDN P-0-3000.0.31

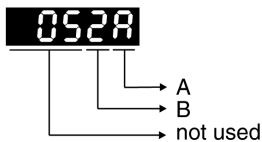
Parameter name	Description	Unit Minimum value Factory setting Maximum value HMI Format	Data type R/W Persistent	Parameter address via fieldbus
		0 _h FFFFFFFF _h Hexadecimal	-	
P0-32 MAP8	Parameter Mapping 8 See P0-25 and P0-42 for details.	- 0 _h 0 _h FFFFFFFF _h Hexadecimal	u32 RW -	Modbus 140 _h IDN P-0-3000.0.32
P0-35 MAPA1	Block Data Read/Write P0-35...P0-42 1 The parameters P0-35 ... P0-42 specify the required read and write parameter numbers for P0-25 ... P0-32. They read and write the values of the parameters whose communication addresses are not consecutive. The read/write parameter can be a single 32-bit parameter or two 16-bit parameters.  A: Parameter group code in hexadecimal format B: Parameter number in hexadecimal format Example: If you want to read and write the value of P1-44 (32-bit parameter) via P0-25, set P0-35 to 012C012C _h . If you want to read and write the values of P2-02 (16-bit parameter) and P2-04 (16-bit parameter) via P0-25, set P0-35 to 02040202 _h .	- 0 _h 0 _h FFFFFFFF _h Hexadecimal	u32 RW per.	Modbus 146 _h IDN P-0-3000.0.35
P0-36 MAPA2	Block Data Read/Write P0-35...P0-42 2 See P0-35 for details.	- 0 _h 0 _h FFFFFFFF _h Hexadecimal	u32 RW per.	Modbus 148 _h IDN P-0-3000.0.36
P0-37 MAPA3	Block Data Read/Write P0-35...P0-42 3 See P0-35 for details.	- 0 _h 0 _h FFFFFFFF _h Hexadecimal	u32 RW per.	Modbus 14A _h IDN P-0-3000.0.37
P0-38 MAPA4	Block Data Read/Write P0-35...P0-42 4 See P0-35 for details.	- 0 _h 0 _h FFFFFFFF _h Hexadecimal	u32 RW per.	Modbus 14C _h IDN P-0-3000.0.38

Parameter name	Description	Unit Minimum value Factory setting Maximum value HMI Format	Data type R/W Persistent	Parameter address via fieldbus
P0-39 MAPA5	Block Data Read/Write P0-35...P0-42 5 See P0-35 for details.	- 0 _h 0 _h FFFFFFFF _h Hexadecimal	u32 RW per.	Modbus 14E _h IDN P-0-3000.0.39
P0-40 MAPA6	Block Data Read/Write P0-35...P0-42 6 See P0-35 for details.	- 0 _h 0 _h FFFFFFFF _h Hexadecimal	u32 RW per.	Modbus 150 _h IDN P-0-3000.0.40
P0-41 MAPA7	Block Data Read/Write P0-35...P0-42 7 See P0-35 for details.	- 0 _h 0 _h FFFFFFFF _h Hexadecimal	u32 RW per.	Modbus 152 _h IDN P-0-3000.0.41
P0-42 MAPA8	Block Data Read/Write P0-35...P0-42 8 See P0-35 for details.	- 0 _h 0 _h FFFFFFFF _h Hexadecimal	u32 RW per.	Modbus 154 _h IDN P-0-3000.0.42

Parameter name	Description	Unit Minimum value Factory setting Maximum value HMI Format	Data type R/W Persistent	Parameter address via fieldbus
<p>P0-46</p> <p>SVSTS</p>	<p>State of Signal Output Functions</p> <p>This parameter is used to indicate the state of the signal output function of the drive in hexadecimal format. If the function is assigned to a digital output, it would represent the state of the output given no forcing on the output.</p> <p>Bit 0: SRDY (Servo ready)</p> <p>Bit 1: SON (Servo On)</p> <p>Bit 2: ZSPD (Zero speed)</p> <p>Bit 3: TSPD (Speed reached)</p> <p>Bit 4: TPOS (Movement completed)</p> <p>Bit 5: TQL (Torque Limit Reached)</p> <p>Bit 6: ERR (Error Detected)</p> <p>Bit 7: BRKR (Holding brake control)</p> <p>Bit 8: HOMED_OK (Homing completed)</p> <p>Bit 9: OLW (Motor Overload Alert)</p> <p>Bit 10: WARN (indicates that one of the following conditions has been detected: Hardware limit switch triggered, undervoltage, Nodeguard alert, Operational Stop (OPST))</p> <p>Bits 11 ... 15: Reserved</p> <p>The parameter can also be read via the fieldbus.</p>	<p>-</p> <p>0_h</p> <p>0_h</p> <p>FFFF_h</p> <p>Hexadecimal</p>	<p>u16</p> <p>RO</p> <p>-</p>	<p>Modbus 15C_n</p> <p>IDN P-0-3000.0.46</p>
<p>P0-47</p> <p>LAST_WRN</p>	<p>Number of Last Alert</p> <p>This parameter contains the number of the last detected alert. After a Fault Reset, the number is cleared.</p>	<p>-</p> <p>0_h</p> <p>0_h</p> <p>FFFF_h</p> <p>Hexadecimal</p>	<p>u16</p> <p>RO</p> <p>-</p>	<p>Modbus 15E_n</p> <p>IDN P-0-3000.0.47</p>

P1 - Basic Parameters

P1 - Basic Parameters

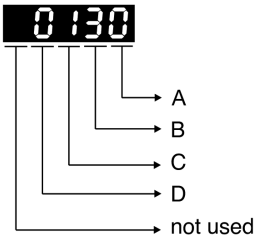
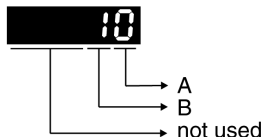
Parameter name	Description	Unit Minimum value Factory setting Maximum value HMI Format	Data type R/W Persistent	Parameter address via fieldbus
P1-01 CTL	<p>Operating Mode and Direction of Rotation</p>  <p>AB: Operating Mode</p> <p>This parameter indicates which field bus communication is selected by P3-08, page 193.</p> <ul style="list-style-type: none"> • 0x99: IO mode • 0x30: Sercos communication mode on M262 controller • 0x50: Sercos communication mode on LMC078 controller <p>C: Direction of movement</p> <p>Refer to chapter <i>Verifying the Direction of Movement</i>, page 146.</p> <p>D: Signal input functions and signal output functions after operating mode switching</p> <p>Value 0: The assignments of the signal input functions and the signal output functions (P2-10 ... P2-21) remain identical for the new operating mode.</p> <p>Value 1: The assignments of the signal input functions and the signal output functions (P2-10 ... P2-21) are set to the default presets of the new operating mode. Refer to chapters <i>Default Presets of the Signal Inputs</i>, page 225 and <i>Default Presets of the Signal Outputs</i>, page 226.</p> <p>Modified settings become active the next time the product is powered on.</p>	- 30 _h 30 _h 1150 _h Hexadecimal	u16 RW per.	Modbus 202 _h IDN P-0-4001.0.1
P1-02 PSTL	<p>Velocity and Torque Limitations Activation/Deactivation</p> <p>This parameter activates/deactivates velocity limitation and torque limitation.</p>  <p>A: Velocity limitation</p> <p>0: Deactivate</p> <p>1: Activate (in operating mode SERCOS III T (refer to P1-82))</p>	- 0 _h 0 _h 11 _h Hexadecimal	u16 RW per.	Modbus 204 _h IDN P-0-4001.0.2

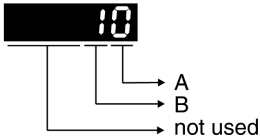
Parameter name	Description	Unit Minimum value Factory setting Maximum value HMI Format	Data type R/W Persistent	Parameter address via fieldbus
	B: Torque limitation 0: Deactivate 1: Activate (operating modes SERCOS III V (refer to P1-85))			
P1-03 AOUT	Polarity of Pulse Outputs  <p>This parameter is used to specify the polarity of pulse outputs.</p> B: Polarity of pulse outputs 0: Not inverted 1: Inverted	- 0 _h 0 _h 10 _h Hexadecimal	u16 RW per.	Modbus 206 _h IDN P-0-4001.0.3
P1-06 DCOMopmod	SERCOS III Opmode	% -32768 0 32767 Decimal	s16 RO -	Modbus 20C _h IDN P-0-4001.0.6
P1-07 ReactLimSw	Limit Switch Fault Reaction Error reaction selection after a limit switch is at active state while the power stage is disabled 1: The drive does not trigger an error 0: The drive triggers an error	- 0 1 1 Decimal	u16 RW per.	Modbus 20E _h IDN P-0-4001.0.7
P1-09 SP1	Velocity Limitation 1	0.1rpm -60000 10000 60000 Decimal	s32 RW per.	Modbus 212 _h IDN P-0-4001.0.9
P1-10 SP2	Velocity Limitation 2	0.1rpm -60000 20000 60000 Decimal	s32 RW per.	Modbus 214 _h IDN P-0-4001.0.10
P1-11 SP3	Velocity Limitation 3	0.1rpm -60000 30000 60000 Decimal	s32 RW per.	Modbus 216 _h IDN P-0-4001.0.11
P1-12	Torque Limitation 1	%	s16	Modbus 218 _h

Parameter name	Description	Unit Minimum value Factory setting Maximum value HMI Format	Data type R/W Persistent	Parameter address via fieldbus
TQ1	The signal output function TQL is activated if the torque reaches the torque limitations set via the parameters P1-12 ... P1-14.	-300 100 300 Decimal	RW per.	IDN P-0-4001.0.12
P1-13 TQ2	Torque Limitation 2 The signal output function TQL is activated if the torque reaches the torque limitations set via the parameters P1-12 ... P1-14.	% -300 100 300 Decimal	s16 RW per.	Modbus 21A _h IDN P-0-4001.0.13
P1-14 TQ3	Torque Limitation 3 The signal output function TQL is activated if the torque reaches the torque limitations set via the parameters P1-12 ... P1-14.	% -300 100 300 Decimal	s16 RW per.	Modbus 21C _h IDN P-0-4001.0.14
P1-15 LINELOSSMODE	Mains Phase Monitoring - Response to Missing Mains Phase This parameter specifies the response of the drive if the mains phase monitoring function detects an error. Value 0: Detected error if power stage is enabled or disabled Value 1: Detected error if power stage is enabled, alert if power stage is disabled Value 2: Alert if power stage is enabled or disabled	- 0 0 2 Decimal	u16 RW per.	Modbus 21E _h IDN P-0-4001.0.15
P1-16 LINELOSSRECOVER	Mains Phase Monitoring - Fault Reset This parameter specifies the type of Fault Reset after a detected mains phase error has been removed. Value 0: No automatic Fault Reset Value 1: Automatic Fault Reset	- 0 0 1 Decimal	u16 RW per.	Modbus 220 _h IDN P-0-3001.0.16
P1-17 LINELOSSTYPE	Mains Phase Monitoring - Type This parameter specifies the type of mains phase monitoring Value 0: No mains phase monitoring Value 1: Mains phase monitoring single-phase connection Value 2: Mains phase monitoring three-phase connection	- 0 0 2 Decimal	u16 RW per.	Modbus 222 _h IDN P-0-3001.0.17
P1-19 DISTIME	Active Disable - Delay Time Power Stage This parameter specifies the delay time between standstill of the motor and disabling the power stage.	ms 0 0 6500 Decimal	u16 RW per.	Modbus 226 _h IDN P-0-4001.0.19
P1-20	Current Limit During Quick Stop	0.001	s16	Modbus 228 _h

Parameter name	Description	Unit Minimum value Factory setting Maximum value HMI Format	Data type R/W Persistent	Parameter address via fieldbus
ESTOPI LIM	This parameter specifies the maximum current during a Quick Stop (expressed as factor of P1-78).	1 1000 1000 Decimal	RW per.	IDN P-0-4001.0.20
P1-21 FOLD	Status of Foldback Current Drive This parameter indicates whether the foldback current limit is greater than or less than the maximum current of the drive (see P1-78). Value 0: Foldback current limit greater than P1-78 Value 1: Foldback current limit is less than P1-78	- 0 - 1 Decimal	u16 RO -	Modbus 22A _n IDN P-0-4001.0.21
P1-22 IFOLD	Foldback Current Limit - Drive Drive foldback current limit	0.01A 0 - 30000 Decimal	u32 RO -	Modbus 22C _n IDN P-0-4001.0.22
P1-23 IFOLD FTHRESH	Current Monitoring Drive - Detected Error Threshold Foldback Current This parameter specifies the threshold value used by the drive current monitoring function to detect a drive foldback current error.	0.01A 0 - 30000 Decimal	u32 RW per.	Modbus 22E _n IDN P-0-4001.0.23
P1-24 IFOLD WTHRESH	Current Monitoring Drive - Alert Threshold Foldback Current This parameter specifies the threshold value used by the drive current monitoring function to trigger a drive foldback current alert.	0.01A 0 - 30000 Decimal	u32 RW per.	Modbus 230 _n IDN P-0-4001.0.24
P1-25	Reserved	-	-	-
P1-26 MIFOLD	Foldback Current Limit - Motor Motor foldback current limit	0.01A 0 - 30000 Decimal	u32 RO -	Modbus 234 _n IDN P-0-4001.0.26
P1-27 MIFOLD FTHRESH	Motor Current Monitoring - Detected Error Threshold Foldback Current This parameter specifies the threshold value used by the motor current monitoring function to detect a motor foldback current error.	0.01A 0 - 30000 Decimal	u32 RW per.	Modbus 236 _n IDN P-0-3001.0.27
P1-28 MIFOLD WTHRESH	Motor Current Monitoring - Alert Threshold Foldback Current This parameter specifies the threshold value used by the motor current monitoring function to trigger a motor foldback current alert.	0.01A 0 - 30000 Decimal	u32 RW per.	Modbus 238 _n IDN P-0-4001.0.28

Parameter name	Description	Unit Minimum value Factory setting Maximum value HMI Format	Data type R/W Persistent	Parameter address via fieldbus
P1-29 OVTHRESH	DC Bus Overvoltage Monitoring - Threshold This parameter specifies the threshold value used by the DC bus overvoltage monitoring function.	V - - Decimal	u16 RO -	Modbus 23A _h IDN P-0-4001.0.29
P1-30 COMMERRMAXCNT	Commutation Monitoring - Maximum Counter Value	ms 0 0 0 Decimal	u16 RW -	Modbus 23C _h IDN P-0-4001.0.30
P1-32 LSTP	Stop Method This parameter specifies how the motor is stopped if the power stage is to be disabled (includes signal input function OPST) or if an error is detected. Value 0 _h : Deceleration ramp Value 10 _h : Coast to stop Value 20 _h : Deceleration ramp to velocity P1-38, then coast to stop (actual velocity must be less than the value of P1-38 for 50 ms before coasting to stop starts) Depending on the event that triggered the stop, the following deceleration ramps are used: - Transmission error detected: P5-21 - Position overflow: P5-22 - Triggering of negative software limit switch: P5-23 - Triggering of positive software limit switch: P5-24 - Triggering of negative hardware limit switch: P5-25 - Triggering of positive hardware limit switch: P5-26 - Any other event: P1-68 The delay time between standstill of the motor and disabling the power stage is set via P1-19.	- 0 _h 0 _h 20 _h Hexadecimal	u16 RW per.	Modbus 240 _h IDN P-0-4001.0.32
P1-34 TACC	Acceleration Period The acceleration period is the time in milliseconds required to accelerate from motor standstill to 6000 rpm.	ms 6 30 65500 Decimal	u16 RW per.	Modbus 244 _h IDN P-0-4001.0.34
P1-35 TDEC	Deceleration Period The deceleration period is the time in milliseconds required to decelerate from 6000 rpm to motor standstill.	ms 6 30 65500 Decimal	u16 RW per.	Modbus 246 _h IDN P-0-4001.0.35

Parameter name	Description	Unit Minimum value Factory setting Maximum value HMI Format	Data type R/W Persistent	Parameter address via fieldbus
P1-37 LMJR	Ratio of Load Inertia to Motor Inertia This parameter specifies the ratio of load inertia to motor inertia (J_{load} / J_{motor}). J_{load} : Total moment of inertia of external mechanical load J_{motor} : Moment of inertia of motor	0.1 0 10 20000 Decimal	u32 RW per.	Modbus 24A _n IDN P-0-4001.0.37
P1-38 ZSPD	Signal Output Function ZSPD This parameter specifies the velocity for the signal output function ZSPD. The signal output function ZSPD indicates that the velocity of the motor is less than the velocity value set via this parameter.	0.1rpm 0 100 2000 Decimal	s32 RW per.	Modbus 24C _n IDN P-0-3006.0.27
P1-39 SSPD	Signal Output Function TSPD - Velocity This parameter specifies the velocity for the signal output function TSPD. The signal output function TSPD indicates that the velocity of the motor is greater than the velocity value set via this parameter.	rpm 0 3000 5000 Decimal	u32 RW per.	Modbus 24E _n IDN P-0-4001.0.39
P1-42 MBT1	ON Delay Time of Holding Brake This parameter specifies the time between enabling the power stage and starting a movement (opening time for the holding brake).	ms 0 0 1000 Decimal	u16 RW per.	Modbus 254 _n IDN P-0-3005.0.7
P1-44 GR1	Electronic Gear Ratio - Numerator 1 This parameter is used to set the numerator of the gear ratio. The denominator of the gear ratio is set via P1-45.	- 1 536870911 Decimal	u32 RW per.	Modbus 258 _n IDN P-0-4001.0.44
P1-45 GR2	Electronic Gear Ratio - Denominator This parameter is used to set the denominator of the gear ratio. The numerator of the gear ratio is set via P1-44. Setting can only be modified if power stage is disabled.	- 1 2147483647 Decimal	u32 RW per.	Modbus 25A _n IDN P-0-4001.0.45
P1-46 ENCOUTRES	Number of encoder simulation increments (AB signal) per revolution The calculation of the range of this parameter depends on the value of P1-55. Setting can only be modified if power stage is disabled.	LPR - 2048 - Decimal	s32 RW per.	Modbus 25C _n IDN P-0-4001.0.46
P1-52 REGENRES	Braking Resistor - Resistance This parameter is used to set the resistance of the braking resistor. Value -1: No braking resistor	Ohm -1 - 32767 Decimal	s16 RW per.	Modbus 268 _n IDN P-0-3001.0.52
P1-53 REGENPOW	Braking Resistor - Power	W -1	s16 RW	Modbus 26A _n IDN P-0-3001.0.53

Parameter name	Description	Unit Minimum value Factory setting Maximum value HMI Format	Data type R/W Persistent	Parameter address via fieldbus
	This parameter is used to set the power of the braking resistor. Value -1: No braking resistor	- 32767 Decimal	per.	
P1-54 PER	Signal Output Function TPOS - Trigger Value This parameter specifies the position deviation value used to activate the signal output function TPOS.	PUU 0 1311 1280000 Decimal	u32 RW per.	Modbus 26C _h IDN P-0-3001.0.54
P1-55 VLIM	Maximum Velocity - User-Defined This parameter specifies the maximum velocity. Factory setting: maximum motor speed. Setting can only be modified if power stage is disabled.	rpm 10 - 6000 Decimal	u32 RW per.	Modbus 26E _h IDN P-0-3017.0.16
P1-57 CRSHA	Torque Monitoring - Torque Value This parameter is used to configure the torque monitoring function. The torque monitoring function detects an error (AL030) if the torque value set via this parameter is exceeded for a period of time set via P1-58.	% 0 0 300 Decimal	u16 RW per.	Modbus 272 _h IDN P-0-3001.0.57
P1-58 CRSHT	Torque Monitoring - Time Value This parameter is used to configure the torque monitoring function. The torque monitoring function detects an error (AL030) if the torque value set via P1-57 is exceeded for a period of time set via this parameter.	ms 1 1 1000 Decimal	u16 RW per.	Modbus 274 _h IDN P-0-3001.0.58
P1-59 VELCMDMOVEAVG	S Curve Filter for Operating Mode Velocity This parameter specifies the moving average time in [us] for the S curve filter in the operating mode Velocity. The value of this parameter must be a multiple of 125. This filter changes a linear acceleration into an S curve. Setting can only be modified if power stage is disabled.	us 0 0 255875 Decimal	u32 RW per.	Modbus 276 _h IDN P-0-3001.0.59
P1-60 COMMERRT- THRESH	Commutation Monitoring - Time Threshold	ms 0 0 3000 Decimal	u16 RW per.	Modbus 278 _h IDN P-0-3001.0.60
P1-61 COMMERRV- THRESH	Commutation Monitoring - Velocity Threshold	0.1rpm 0 600 60000 Decimal	u32 RW per.	Modbus 27A _h IDN P-0-3001.0.61
P1-62	Motor Overtemperature Monitoring - Response	-	u16	Modbus 27C _h

Parameter name	Description	Unit Minimum value Factory setting Maximum value HMI Format	Data type R/W Persistent	Parameter address via fieldbus
THERMODE	This parameter specifies the response of the drive if the temperature monitoring function detects motor overtemperature. Value 0: Disable power stage immediately Value 3: Ignore overtemperature Value 4: Alert Value 5: Alert first, then detected error if condition persists after P1-63	0 0 5 Decimal	RW per.	IDN P-0-3001.0.62
<i>P1-63</i> THERMTIME	Motor Overtemperature Monitoring - Delay Time This parameter specifies the delay time between the detection of motor overtemperature and the transition to the operating state Fault (see P1-62).	s 0 30 300 Decimal	u16 RW per.	Modbus 27E _h IDN P-0-3001.0.63
<i>P1-64</i> UVMODE	Undervoltage Monitoring - Response This parameter specifies the response of the drive if the undervoltage monitoring function detects undervoltage. Value 0: Detected error Value 1: Alert (if power stage is enabled) Value 2: Alert first, then detected error if condition persists after P1-67 (if power stage is enabled) Value 3: Detected error (if power stage is enabled)	- 0 0 3 Decimal	u16 RW per.	Modbus 280 _h IDN P-0-3001.0.64
<i>P1-66</i> MFOLD	Status of Foldback Current Motor This parameter indicates whether the foldback current limit is greater than or less than the maximum current of the motor (see P1-78). Value 0: Foldback current limit greater than P1-78 Value 1: Foldback current limit is less than P1-78	- 0 - 1 Decimal	u16 RO -	Modbus 284 _h IDN P-0-3001.0.66
<i>P1-67</i> UVTIME	Undervoltage Monitoring - Delay Time This parameter specifies the delay time between the detection of an undervoltage condition (displayed as "u") and the response of the drive to this condition as specified in P1-64.	s 0 30 300 Decimal	u16 RW per.	Modbus 286 _h IDN P-0-3001.0.67
<i>P1-68</i> DECSTOP	Active Disable - Deceleration Ramp This parameter specifies the deceleration ramp for a power stage Disable request, see P1-32.	ms 6 30 65500 Decimal	u16 RW per.	Modbus 288 _h IDN P-0-3001.0.68
<i>P1-69</i> DECSTOPTIME	Disable - Deceleration Time This parameter specifies the deceleration ramp for a power stage Disable request, see P1-32. If the value of this parameter is not 0, this parameter overrides P1-68. Setting can only be modified if power stage is disabled.	ms 0 0 6500 Decimal	u16 RW per.	Modbus 28A _h IDN P-0-3001.0.69

Parameter name	Description	Unit	Data type	Parameter address via fieldbus
		Minimum value Factory setting Maximum value HMI Format	R/W Persistent	
P1-71 REGENMAXONTIME	Braking Resistor - Maximum Time in Braking This parameter specifies the maximum time in braking for the braking resistor. The maximum time in braking is the maximum period of time during which the braking resistor may be activated.	ms 10 40 100 Decimal	u16 RW per.	Modbus 28E _h IDN P-0-3001.0.71
P1-72 REGENFLTMODE	Braking Resistor Overload Monitoring - Response This parameter specifies the response of the drive if the braking resistor overload monitoring function detects braking resistor overload. Value 0: Alert Value 1: Detected error	- 0 0 1 Decimal	u16 RW per.	Modbus 290 _h IDN P-0-3001.0.72
P1-78 ILIM	User-Defined Maximum Current This parameter is specifies a user-defined maximum current for the drive. The maximum value of this parameter is the value of P1-79.	0.01A - - - Decimal	u32 RW per.	Modbus 29C _h IDN P-0-4001.0.78
P1-79 IMAX	Maximum Current This parameter indicates the maximum current for a drive / motor combination.	0.01A - - - Decimal	u32 RO -	Modbus 29E _h IDN P-0-3017.0.12
P1-80 DIPEAK	Maximum Peak Current This parameter indicates the maximum peak current of the drive.	0.01A - - - Decimal	u32 RO -	Modbus 2A0 _h IDN P-0-3001.0.80
P1-81 DICONT	Nominal Current This parameter indicates the nominal current of the drive.	0.01A - - - Decimal	u32 RO -	Modbus 2A2 _h IDN P-0-3001.0.81
P1-82 FIELDDBUS_VEL_LIMIT	Velocity limitation for operating mode Profile Torque The limitation is effective only if P1-02 is set to 0x0001. Value 0: Value 1: Limitation via P1-09 Value 2: Limitation via P1-10 Value 3: Limitation via P1-11	- 0 0 3 Decimal	u16 RW per.	Modbus 2A4 _h IDN P-0-3001.0.82
P1-84 CFG_MOTOR	Configured motor type	- 0 -	u32 RW per.	Modbus 2A8 _h IDN P-0-3001.0.84

Parameter name	Description	Unit Minimum value Factory setting Maximum value HMI Format	Data type R/W Persistent	Parameter address via fieldbus
		2147483647 Decimal		
<i>P1-85</i> FIELDDBUS_TRQ_LIMIT	Torque Limit For Modes The limitation is effective only if P1-02 is set to 0x0010. Value 0: Value 1: Limitation via P1-12 Value 2: Limitation via P1-13 Value 3: Limitation via P1-14	- 0 0 3 Decimal	u16 RW per.	Modbus 2AA _n IDN P-0-3001.0.85
<i>P1-87</i> I_MAX_QUICK_STOP	Quick Stop - Maximum Current This parameter is specifies the maximum current at Quick Stop for modes. The limitation is effective only if P3-31 is set to -2 or 7.	0.01A - P1-79 0 Decimal	u32 RW per.	Modbus 2AE _n IDN P-0-3017.0.13

P2 - Extended Parameters

P2 - Extended Parameters

Parameter name	Description	Unit Minimum value Factory setting Maximum value HMI Format	Data type R/W Persistent	Parameter address via fieldbus
<i>P2-01</i> PPR	Gain Switching - Rate for Position Loop This parameter specifies the gain switching rate for the position loop. The gain switching function is configured via this parameter and parameters P2-05, P2-27 and P2-29.	% 10 100 500 Decimal	u16 RW per.	Modbus 302 _n IDN P-0-4002.0.1
<i>P2-05</i> SPR	Gain Switching - Rate for Velocity Loop This parameter specifies the gain switching rate for the velocity loop. The gain switching function is configured via this parameter and parameters P2-01, P2-27 and P2-29.	% 10 100 500 Decimal	u16 RW per.	Modbus 30A _n IDN P-0-4002.0.5
<i>P2-08</i> PCTL	Factory Reset / Save Parameters This parameter provides the following functions: - Reset the parameters to the factory settings - Save the current parameter values The factory settings do not become effective until after you have powered the drive off and on again.	- 0 0 406 Decimal	u16 RW -	Modbus 310 _n IDN P-0-3002.0.8

Parameter name	Description	Unit Minimum value Factory setting Maximum value HMI Format	Data type R/W Persistent	Parameter address via fieldbus
	<p>Value 10: Reset the parameter values to the factory settings</p> <p>Value 11: Save the parameter values</p> <p>Value 400: Normal digital output control operation mode</p> <p>Value 406: Force output control operation mode</p> <p>NOTE: Value 999 is displayed when the parameter values are successfully saved.</p>			
<i>P2-09</i> DRT	<p>Debounce Time - Inputs</p> <p>This parameter specifies the debounce time for the digital inputs DI1 ... DI5 and DI8. See P2-24 for the debounce time for the fast digital inputs DI6 and DI7.</p>	<p>ms</p> <p>0</p> <p>2</p> <p>20</p> <p>Decimal</p>	<p>u16</p> <p>RW</p> <p>per.</p>	<p>Modbus 312_h</p> <p>IDN P-0-3002.0.9</p>
<i>P2-10</i> DITF1	<p>Signal Input Function for DI1</p> <p>The parameters P2-10 ... P2-17 are used to assign signal input functions to the digital inputs DI1 ... DI8 and to configure the type of digital input (normally closed, normally open).</p> <p>A: Signal input functions:</p> <p>For the values, refer to chapter Setting the Digital Signal Inputs, page 225.</p> <p>B: Type:</p> <p>0: Normally closed (contact b)</p> <p>1: Normally open (contact a)</p> <p>Example: If the setting of P2-10 is 101, the signal input function assigned to digital input 1 is SON (0x01) and the type of contact is a normally open contact.</p> <p>The drive must be restarted after the parameters have been modified.</p> <p>Forcing of digital inputs is configured via P3-06 and activated via P4-07.</p> <p>Setting can only be modified if power stage is disabled.</p>	<p>-</p> <p>0_h</p> <p>146_h</p> <p>Hexadecimal</p>	<p>u16</p> <p>RW</p> <p>per.</p>	<p>Modbus 314_h</p> <p>IDN P-0-3007.0.1</p>
<i>P2-11</i> DITF2	<p>Signal Input Function for DI2</p> <p>See P2-10 for details.</p> <p>Setting can only be modified if power stage is disabled.</p>	<p>-</p> <p>0_h</p> <p>100_h</p> <p>146_h</p> <p>Hexadecimal</p>	<p>u16</p> <p>RW</p> <p>per.</p>	<p>Modbus 316_h</p> <p>IDN P-0-3007.0.2</p>
<i>P2-12</i> DITF3	<p>Signal Input Function for DI3</p> <p>See P2-10 for details.</p> <p>Setting can only be modified if power stage is disabled.</p>	<p>-</p> <p>0_h</p> <p>100_h</p> <p>146_h</p> <p>Hexadecimal</p>	<p>u16</p> <p>RW</p> <p>per.</p>	<p>Modbus 318_h</p> <p>IDN P-0-3007.0.3</p>
<i>P2-13</i> DITF4	<p>Signal Input Function for DI4</p> <p>See P2-10 for details.</p>	<p>-</p> <p>0_h</p>	<p>u16</p> <p>RW</p>	<p>Modbus 31A_h</p> <p>IDN P-0-3007.0.4</p>

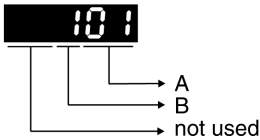
Parameter name	Description	Unit Minimum value Factory setting Maximum value HMI Format	Data type R/W Persistent	Parameter address via fieldbus
	Setting can only be modified if power stage is disabled.	100 _h 146 _h Hexadecimal	per.	
P2-14 DITF5	Signal Input Function for DI5 See P2-10 for details. Setting can only be modified if power stage is disabled.	- 0 _h 24 _h 146 _h Hexadecimal	u16 RW per.	Modbus 31C _h IDN P-0-3007.0.5
P2-15 DITF6	Signal Input Function for DI6 See P2-10 for details. Setting can only be modified if power stage is disabled.	- 0 _h 22 _h 146 _h Hexadecimal	u16 RW per.	Modbus 31E _h IDN P-0-3007.0.6
P2-16 DITF7	Signal Input Function for DI7 See P2-10 for details. Setting can only be modified if power stage is disabled.	- 0 _h 23 _h 146 _h Hexadecimal	u16 RW per.	Modbus 320 _h IDN P-0-3007.0.7
P2-17 DITF8	Signal Input Function for DI8 See P2-10 for details. Setting can only be modified if power stage is disabled.	- 0 _h 21 _h 146 _h Hexadecimal	u16 RW per.	Modbus 322 _h IDN P-0-3007.0.8
P2-18 DOTF1	Signal Output Function for DO1 The parameters P2-18 ... P2-21 are used to assign signal output functions to the digital outputs DO1 ... DO4 and to configure the type of digital output (normally closed, normally open).  A: Signal output functions: For the values, refer to chapter Setting the Digital Signal Outputs, page 226. B: Type: 0: Normally closed (contact b) 1: Normally open (contact a) Example: If the setting of P2-18 is 101, the signal output function assigned to digital output 1 is SRDY (0x01) and the type of contact is a normally open contact.	- 0 _h 101 _h 137 _h Hexadecimal	u16 RW per.	Modbus 324 _h IDN P-0-3007.0.9
P2-19	Signal Output Function for DO2	-	u16	Modbus 326 _h

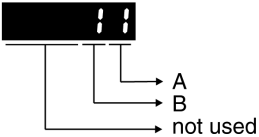
Parameter name	Description	Unit Minimum value Factory setting Maximum value HMI Format	Data type R/W Persistent	Parameter address via fieldbus
DOTF2	See P2-18 for details.	0 _h 100 _h 137 _h Hexadecimal	RW per.	IDN P-0-3002.0.19
P2-20 DOTF3	Signal Output Function for DO3 See P2-18 for details.	- 0 _h 137 _h Hexadecimal	u16 RW per.	Modbus 328 _h IDN P-0-3007.0.10
P2-21 DOTF4	Signal Output Function for DO4 See P2-18 for details.	- 0 _h 100 _h 137 _h Hexadecimal	u16 RW per.	Modbus 32A _h IDN P-0-3007.0.11
P2-23 DOTF6	Signal Output Function for OCZ Only the signal output function ESIM can be assigned to the digital output OCZ. Value 0: Encoder simulation function disabled Value 40 _(h) : Encoder simulation function enabled Use P2-18 ... for assigning other signal output functions to the other digital outputs DO1 ... See P2-18 for details.	- 0 _h 40 _h 137 _h Hexadecimal	u16 RO per.	Modbus 32E _h IDN P-0-3007.0.14
P2-24 FDRT	Debounce Time - Fast Inputs This parameter specifies the debounce time for the digital inputs DI6 and DI7. See P2-09 for the debounce time for the digital inputs DI1 ... DI5 and DI8.	us 0 50 16383 Decimal	u16 RW per.	Modbus 330 _h IDN P-0-4002.0.24
P2-27 GCC	Gain Switching - Conditions and Type This parameter specifies the conditions for and the type of gain switching. The gain switching function is configured via this parameter and parameters P2-01, P2-05 and P2-29.  A: Conditions for gain switching: 0: Disabled 1: Signal input function GAINUP is active 2: In operating modes Profile Position, the position deviation is greater than the value of P2-29 3: Pulse frequency is greater than the value of P2-29 4: Velocity is greater than the value of P2-29	- 0 _h 0 _h 18 _h Hexadecimal	u16 RW per.	Modbus 336 _h IDN P-0-4002.0.27

Parameter name	Description	Unit Minimum value Factory setting Maximum value HMI Format	Data type R/W Persistent	Parameter address via fieldbus
	5: Signal input function GAINUP is not active 6: In operating modes Profile Position, the position deviation is less than the value of P2-29 7: Pulse frequency is less than the value of P2-29 8: Velocity is less than the value of P2-29			
P2-29 GPE	Gain Switching - Comparison Value This parameter specifies the comparison value used for the conditions for gain switching. Depending on the selected condition, the value entered represents the number of pulses (position deviation), the pulse frequency or the velocity. The gain switching function is configured via this parameter and parameters P2-01, P2-05 and P2-27.	- 0 _h 138800 _h 3A9800 _h Hexadecimal	u32 RW per.	Modbus 33A _h IDN P-0-4002.0.29
P2-30 INH	Auxiliary Functions Value 0: Disabled Value 1: Enable the power stage	- -8 0 8 Decimal	s16 RW -	Modbus 33C _h IDN P-0-4002.0.30
P2-31 LTNEFFORT	Autotuning Optimization Value Threshold This parameter is used to modify the gain.	0.001 100 1000 10000 Decimal	u32 RW -	Modbus 33E _h IDN P-0-4002.0.31
P2-32 ATMODE	Autotuning This parameter is used to start autotuning with the selected autotuning method. Value 0: Stop Autotuning Value 1: Easy Tuning Value 2: Comfort Tuning [minimum settling time, vibration suppression] Value 3: Comfort Tuning [minimum overshoot, vibration suppression] Value 52: Comfort Tuning [minimum settling time, no vibration suppression] Value 53: Comfort Tuning [minimum overshoot, no vibration suppression]	- 0 0 56 Decimal	u16 RW -	Modbus 340 _h IDN P-0-4002.0.32
P2-34 VEMAX	Velocity Monitoring - Threshold Value This parameter specifies the velocity threshold for the velocity monitoring function. If this value is exceeded, error AL555 is detected.	0.1rpm 0 50000 60000 Decimal	u32 RW per.	Modbus 344 _h IDN P-0-4002.0.34
P2-35 PDEV	Position Deviation Monitoring - Threshold Value This parameter specifies the position deviation threshold for the position deviation monitoring function. If this value is exceeded, error AL009 is detected.	10*pulse 1 384000 12800000	u32 RW per.	Modbus 346 _h IDN P-0-3006.0.62

Parameter name	Description	Unit Minimum value Factory setting Maximum value HMI Format	Data type R/W Persistent	Parameter address via fieldbus
		Decimal		
<p><i>P2-50</i> DCLR</p>	<p>Signal Input Function CLRPOS - Trigger</p> <p>This function is only supported in linear control mode (P8-35=0x4001)</p> <p>This parameter specifies how the signal input function CLRPOSDEV is triggered. The signal input function CLRPOSDEV resets the position deviation to zero.</p> <p>Value 0: Rising edge Value 1: Level</p>	<p>-</p> <p>0_h</p> <p>0_h</p> <p>1_h</p> <p>Hexadecimal</p>	<p>u16</p> <p>RW</p> <p>per.</p>	<p>Modbus 364_h</p> <p>IDN P-0-3002.0.50</p>
<p><i>P2-65</i> GBIT</p>	<p>Special Function 1</p> <p>Bits 0 ... 1: Reserved (must be set to 0).</p> <p>Bit 2: Activate/deactivate the error AL560</p> <ul style="list-style-type: none"> • 0: The alarm can be triggered • 1: The alarm cannot be triggered <p>Bit 4: Target position rejected monitoring</p> <ul style="list-style-type: none"> • 0: Function activated (AL520) • 1: Function deactivated <p>Bit 5: Current limitation in torque mode</p> <ul style="list-style-type: none"> • 0: Function activated • 1: Function deactivated <p>Bit 6: Reference pulse monitoring</p> <ul style="list-style-type: none"> • 0: Function activated • 1: Function deactivated <p>Bit 7: Pulse signal monitoring</p> <ul style="list-style-type: none"> • 0: Function activated (AL534) • 1: Function deactivated <p>Bit 8: Motor overload monitoring</p> <ul style="list-style-type: none"> • 0: Function activated (AL006) • 1: Function deactivated <p>Bit 9: Motor phase monitoring</p> <ul style="list-style-type: none"> • 0: Function deactivated • 1: Function activated <p>Bit 11: NL(CWL)/PL(CCWL) pulse input inhibit function</p> <ul style="list-style-type: none"> • 0: Function activated • 1: Function deactivated <p>If P8-31 is set to 1 or 3 and if a hardware limit switch is triggered, a Fault Reset clears the missing master pulses. Only use the pulse inhibit function with settings 1 or 3 of P8-31 if you do not need a Fault Reset after a detected hardware limit switch error. To achieve this, set the Automatic Fault Reset function of P2-68 to 1.</p> <p>Bit 12: Mains phase monitoring</p> <ul style="list-style-type: none"> • 0: Function activated (AL022) • 1: Function deactivated <p>Bit 13: Encoder simulation output monitoring</p> <ul style="list-style-type: none"> • 0: Function activated (AL018) • 1: Function deactivated <p>Bit 14: Unit of P8-33</p> <ul style="list-style-type: none"> • 0: P8-33 is in Hz 	<p>-</p> <p>0_h</p> <p>200_h</p> <p>FFFC_h</p> <p>Hexadecimal</p>	<p>u16</p> <p>RW</p> <p>per.</p>	<p>Modbus 382_h</p> <p>IDN P-0-3002.0.65</p>

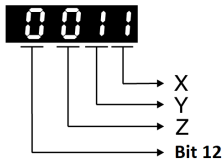
Parameter name	Description	Unit Minimum value Factory setting Maximum value HMI Format	Data type R/W Persistent	Parameter address via fieldbus
	<ul style="list-style-type: none"> 1: P8-33 is in 0.01Hz Bit 15: Verify whether phases are connected by current injection <ul style="list-style-type: none"> 0: Function activated 1: Function deactivated 			
P2-66 GBIT2	Special Function 2 Bits 0 ... 1: Reserved (must be set to 0). Bit 2: This bit specifies the type of Fault Reset after a detected undervoltage error has been removed. 0: No automatic Fault Reset 1: Automatic Fault Reset Bits 3 ... 7: Reserved (must be set to 0).	- 0 0 4 Decimal	u16 RW per.	Modbus 384 _h IDN P-0-3002.0.66
P2-68 AEAL	Auto-Enable and Automatic Hardware Limit Switch Fault Reset Bit 12 of P2-68 to switch Error or Alert when trigger limit switch for IO output function <ul style="list-style-type: none"> 0: Digital Output (0x11) Alert Signal Activated = TRUE 1: Digital Output (0x07) ERROR Detected = TRUE  <p>X: Reserved Y: Reserved Z: Repeated attempt to overtravel limit switch</p> <p>0: No detected error 1: Detected error, Fault Reset required</p> <p>Modified settings become active the next time the product is powered on.</p>	- 0 _h 0 _h 1111 _h Hexadecimal	u16 RW per.	Modbus 388 _h IDN P-0-3002.0.68
P2-71 FOLDBACK_FAULT_TRIG_IMM	FOLDBACK_FAULT_TRIG_IMM Applicable operating mode: PT, PS, V, T. This parameter activates the error detecting that the fold back limit is equal to current.	- 0 1 1 Decimal	u16 RW per.	Modbus 38E _h EtherCAT 4247 _h

Parameter name	Description	Unit Minimum value Factory setting Maximum value HMI Format	Data type R/W Persistent	Parameter address via fieldbus
P2-72 MFOLDT_DISPLAY	Motor Foldback Time Constant Applicable operating mode: PT, PS, V, T. This parameter Indicates the value of MFOLDT_INDEX according to P2-73, page 46.	- 0 0 4294967295 Decimal	u32 RO per.	Modbus 390 _h EtherCAT 4248 _h
P2-73 MFOLDT_INDEX	Motor Foldback Level Applicable operating mode: PT, PS, V, T. This parameter define the level of MFOLDT. The corresponding MFOLDT value is displayed in P2-72.	- 1 1 4 Decimal	u16 RW per.	Modbus 392 _h EtherCAT 4249 _h

P3 - Communication Parameters

P3 - Communication Parameters

Parameter name	Description	Unit Minimum value Factory setting Maximum value HMI Format	Data type R/W Persistent	Parameter address via fieldbus
P3-00 ADR	Device Address Modbus The device address must be unique. Modified settings become active the next time the product is powered on.	- 1 127 247 Decimal	u16 RW per.	Modbus 400 _h IDN P-0-3003.0.0
P3-01 BRT	Transmission Rate This parameter is used to set the data transmission rate. For further information, refer to chapter Setting the Device Address, Baud Rate and Connection Settings, page 143. Modified settings become active the next time the product is powered on.	- 0 _h Hexadecimal	u16 RW per.	Modbus 402 _h IDN P-0-3003.0.1
P3-02 PTL	Modbus Connection Settings This parameter specifies the Modbus connection settings. For further information, refer to chapter Setting the Device Address, Baud Rate and Connection Settings, page 143. Modified settings become active the next time the product is powered on.	- 6 _h 7 _h 9 _h Hexadecimal	u16 RW per.	Modbus 404 _h IDN P-0-3003.0.2
P3-03 FLT	Detected Modbus Communication Errors - Handling	- 0 _h	u16 RW	Modbus 406 _h IDN P-0-3003.0.3

Parameter name	Description	Unit Minimum value Factory setting Maximum value HMI Format	Data type R/W Persistent	Parameter address via fieldbus
	This parameter specifies the response of the drive to a detected communication error. Value 0: Detected alert Value 1: Detected error	0 _h 1 _h Hexadecimal	per.	
P3-04 CWD	Modbus Connection Monitoring This parameter specifies the maximum permissible duration for communication timeout. When this time has elapsed, the communication timeout is treated as a detected error. Setting this parameter to 0 to disables connection monitoring.	ms 0 0 20000 Decimal	u16 RW per.	Modbus 408 _h IDN P-0-3003.0.4
P3-05 CMM	Device Address This parameter specifies the address of the drive in decimal format. The device address must be unique. Modified settings become active the next time the product is powered on.	- 0 0 127 Decimal	u16 RW per.	Modbus 40A _h IDN P-0-3003.0.5
P3-06 SDI	Digital Inputs - Forcing Settings This parameter determines whether or not a digital input can be forced. Bits 0 ... 7: Digital input DI1 ... digital input DI8 Bit settings: Value 0: Digital input cannot be forced Value 1: Digital input can be forced To actually start forcing, you must write P4-07. See P2-10 ... P2-17 for the assignment of signal input functions to the digital inputs.	- 0 _h 0 _h 7FF _h Hexadecimal	u16 RW -	Modbus 40C _h IDN P-0-3003.0.6
P3-07 CDT	Modbus Response Delay Time This parameter specifies the time delay with which the drive responds to the Modbus master.	0.5ms 0 0 1000 Decimal	u16 RW per.	Modbus 40E _h IDN P-0-3003.0.7
P3-08 PROTOCOL	Fieldbus protocol This parameter specifies the active communication protocol. 2: SERCOS III protocol selected (M262 compatible). 4: SERCOS III protocol selected (LMC078 compatible).	- 2 _h 2 _h 4 _h Hexadecimal	u16 RW per.	Modbus 410 _h IDN P-0-3003.0.8
P3-30 INTRN_LIM_SRC	Internal Limit for Bit 11 <i>Status Word S-0-0135</i> This parameter assigns a status information to bit 11 (internal limit active) of the parameter <i>Status Word S-0-0135</i> . Value 0: None: Not used (reserved) Value 1: Current Below Threshold: Current threshold value	- 0 0 11 Decimal	u16 RW per.	Modbus 43C _h IDN P-0-3003.0.30

Parameter name	Description	Unit Minimum value Factory setting Maximum value HMI Format	Data type R/W Persistent	Parameter address via fieldbus
	Value 2: Velocity Below Threshold: Velocity threshold value Value 3: In Position Deviation Window: Position deviation window Value 4: In Velocity Deviation Window: Velocity deviation window Value 9: Hardware Limit Switch: Hardware limit switch Value 11: Position Window: Position window			
P3-31 QSOC	Settings for operating state Quick Stop Value -2: Slow down on torque ramp and switch to Operating State Fault Value -1: Slow down on Quick Stop ramp and switch to Operating State Fault Value 6: Slow down on Quick Stop ramp and stay in Quick stop Active Value 7: Slow down on current limit and stay in Quick stop Active	- -2 6 7 Decimal	s16 RW per.	Modbus 43E _h IDN P-0-3003.0.31
P3-32 SOD2RTSO	Automatic operating state transition from Switch On Disabled to Ready To Switch On Value 0: Automatic transition Value 1: Transition according to value of SERCOS III control word	- 0 _h 0 _h 1 _h Hexadecimal	u16 RW per.	Modbus 440 _h IDN P-0-3003.0.32
P3-33 FBCOMSTATUS	Fieldbus Communication Status Value 0: CP0 Value 1: CP1 Value 2: CP2 Value 3: CP3 Value 4: CP4 Value 5: NRT Value 6: HOTPLUG	- 0 - 6 Decimal	S16 RO -	Modbus 442 _h IDN P-0-3003.0.33

P4 - Diagnostics Parameters

P4 - Diagnostics Parameters

Parameter name	Description	Unit Minimum value Factory setting Maximum value HMI Format	Data type R/W Persistent	Parameter address via fieldbus
P4-00 ASH1	Error History - Error Code of Most Recent Detected Error n This parameter indicates the error code of the most recent detected error. Writing 0 to this parameter clears the error history.	- 0 _h 0 _h FFFF _h Hexadecimal	u16 RW -	Modbus 500 _h IDN P-0-3004.0.0
P4-01 ASH2	Error History - Error Code of Most Recent Detected Error n - 1 This parameter indicates the error code of the detected error n-1, n being the most recent detected error.	- 0 _h 0 _h FFFF _h Hexadecimal	u16 RO -	Modbus 502 _h IDN P-0-3004.1.1
P4-02 ASH3	Error History - Error Code of Most Recent Detected Error n - 2 This parameter indicates the error code of the detected error n-2, n being the most recent detected error.	- 0 _h 0 _h FFFF _h Hexadecimal	u16 RO -	Modbus 504 _h IDN P-0-4004.0.2
P4-03 ASH4	Error History - Error Code of Most Recent Detected Error n - 3 This parameter indicates the error code of the detected error n-3, n being the most recent detected error.	- 0 _h 0 _h FFFF _h Hexadecimal	u16 RO -	Modbus 506 _h IDN P-0-4004.0.3
P4-04 ASH5	Error History - Error Code of Most Recent Detected Error n - 4 This parameter indicates the error code of the detected error n-4, n being the most recent detected error.	- 0 _h 0 _h FFFF _h Hexadecimal	u16 RO -	Modbus 508 _h IDN P-0-4004.0.4
P4-05 JOG	Jog Velocity For further information, refer to chapter Jog Operation, page 240.	rpm 0 20 5000 Decimal	u32 RW per.	Modbus 50A _h IDN P-0-4004.0.5
P4-06 FOT	Forcing Matrix of Digital Outputs This parameter lets you set those signal outputs whose signal output functions have been set to SDO_0 ... SDO_3. Bit 0 = 1 sets those signal outputs whose signal output function has been set to SDO_0. Bit 1 = 1 sets those signal outputs whose signal output function has been set to SDO_1.	- 0 _h 0 _h FF _h Hexadecimal	u16 RW -	Modbus 50C _h IDN P-0-3004.0.6

Parameter name	Description	Unit Minimum value Factory setting Maximum value HMI Format	Data type R/W Persistent	Parameter address via fieldbus
	<p>Bit 2 = 1 sets those signal outputs whose signal output function has been set to SDO_2.</p> <p>Bit 3 = 1 sets those signal outputs whose signal output function has been set to SDO_3.</p> <p>See P2-18 ... P2-21 for assigning the functions to the digital outputs.</p>			
P4-07 ITST	<p>State of Digital Inputs / Activate Forcing</p> <p>A read access to this parameter indicates the state of the digital inputs in the form of a bit pattern.</p> <p>Example: Read value 0x0011: Digital inputs 1 and 5 are logical 1</p> <p>By writing this parameter, you can modify the state of the inputs provided that the setting for the corresponding input in P3-06 allows for forcing (value 1 for the bit corresponding to the input).</p> <p>Example: Write value 0x0011: Digital inputs 1 and 5 are set to logical 1, regardless of the previous state</p> <p>See P3-06 for permitting forcing of individual digital inputs.</p> <p>See P2-10 ... P2-17 for the assignment of signal input functions to the digital inputs.</p>	- 0 _h 0 _h FF _h Hexadecimal	u16 RW -	Modbus 50E _h IDN P-0-3008.0.15
P4-08 PKEY	<p>Status of HMI Keypad</p> <p>This parameter is used to verify proper operation of the keys on the HMI keypad of the drive</p> <p>As a bitwise:</p> <ul style="list-style-type: none"> • "1" - key is pressed, • "0" - key is released. <p>When:</p> <ul style="list-style-type: none"> • S key is indicated by bit0 • M key is indicated by bit1 • UP key is indicated by bit2 • DOWN key is indicated by bit3 • ENT key is indicated by bit4 	- 0 _h 0 _h FF _h Hexadecimal	u16 RO -	Modbus 510 _h IDN P-0-4004.0.8
P4-09 MOT	<p>State of Digital Outputs</p> <p>This parameter indicates the state of the digital outputs DO1...DO6.</p> <p>Bit 0 = 1: DO1 is activated</p> <p>Bit 1 = 1: DO2 is activated</p> <p>Bit 2 = 1: DO3 is activated</p> <p>Bit 3 = 1: DO4 is activated</p> <p>Bit 4 = 1: Reserved</p> <p>Bit 5 = 1: OCZ is activated</p>	- 0 _h 0 _h 3F _h Hexadecimal	u16 RO -	Modbus 512 _h IDN P-0-3008.0.16
P4-10 FLTHISTCLR	<p>Clear Error History</p> <p>Writing 0 to this parameter clears the error history.</p>	- 0 0	u16 RW -	Modbus 514 _h IDN P-0-4004.0.10

Parameter name	Description	Unit Minimum value Factory setting Maximum value HMI Format	Data type R/W Persistent	Parameter address via fieldbus
		0 Decimal		
P4-24 LVL	Undervoltage Monitoring - Threshold Value This parameter specifies the threshold value for DC bus undervoltage monitoring. If the DC Bus voltage is less than the value of P4-24 x $\sqrt{2}$, the error AL003 is detected.	V 140 160 190 Decimal	u16 RW per.	Modbus 530 _h IDN P-0-3004.0.24
P4-25 STO	Safety Function STO - Status This parameter indicates the status of the safety function STO. Bit 0 = 0: Safety function STO triggered Bit 0 = 1: Safety function STO not triggered or deactivated via jumper at CN9	- 0 - 1 Decimal	u16 RO -	Modbus 532 _h IDN P-0-3004.0.25
P4-26 DO_FORCEABLE	Forceable digital outputs This parameter shows whether or not a digital output can be forced. Bits 0 ... 3: Digital output DO1 ... digital output DO4 Bit settings: Value 0: Digital output cannot be forced Value 1: Digital output can be forced	- F _h F _h F _h Hexadecimal	u16 RO -	Modbus 534 _h IDN P-0-3004.0.26
P4-27 DO_FORCE_MASK	Digital output force mask This parameter contains a mask that determines whether or not a digital output can be forced. Bits 0 ... 3: Digital output DO1 ... digital output DO4 Bit settings: Value 0: Digital output cannot be forced Value 1: Digital output can be forced To actually start forcing, you must write P4-28. See P2-18 ... P2-21 for the assignment of signal output functions to the digital outputs.	- 0 _h 0 _h F _h Hexadecimal	u16 RW -	Modbus 536 _h IDN P-0-3004.0.27

Parameter name	Description	Unit Minimum value Factory setting Maximum value HMI Format	Data type R/W Persistent	Parameter address via fieldbus
P4-28 DO_FORCE_VALUE	Digital output force value A read access to this parameter indicates the state of the digital outputs in the form of a bit pattern. Example: Read value 0x0011: Digital output 1 is logical 1 By writing this parameter, you can modify the state of the outputs provided that the setting for the corresponding output in P4-27 allows for forcing (value 1 for the bit corresponding to the output). Example: Write value 0x0011: Digital output 1 is set to logical 1, regardless of the previous state See P4-27 for permitting forcing of individual digital outputs. See P2-18 ... P2-21 for the assignment of signal output functions to the digital outputs.	- 0 _h 0 _h F _h Hexadecimal	u16 RW -	Modbus 538 _h IDN P-0-3004.0.28
P4-29 LOAD_PERIOD_TIME	Motor Load Period Time This parameter specifies the time period in which the average load will be calculated. Modified settings become active the next time the product is powered on.	ms 1 5000 100000 Decimal	u32 RW per.	Modbus 53A _h IDN P-0-3004.0.29

P5 - Motion Settings

P5- Motion Settings

Parameter name	Description	Unit Minimum value Factory setting Maximum value HMI Format	Data type R/W Persistent	Parameter address via fieldbus
P5-00 REV	Firmware Revision This parameter contains the revision number of the firmware.	- 0 _h 0 _h FFFF _h Hexadecimal	u16 RO -	Modbus 600 _h IDN P-0-3005.0.0
P5-04 HMOV	Homing - Homing Method Selection This parameter is used to select the homing method and configure the behavior of the index pulse and the limit switches. For further information, refer to chapter Operating Mode, page 236. Setting can only be modified if power stage is disabled.	- 1 18 35 Decimal	u16 RW per.	Modbus 608 _h IDN P-0-3027.0.12

Parameter name	Description	Unit Minimum value Factory setting Maximum value HMI Format	Data type R/W Persistent	Parameter address via fieldbus
P5-05 HOMESPEED1	Homing - Fast Velocity for Reference Movement	0.1rpm 10 1000 60000 Decimal	u32 RW per.	Modbus 60A _h IDN P-0-3040.0.4
P5-06 HOMESPEED2	Homing - Slow Velocity for Reference Movement	0.1rpm 10 200 60000 Decimal	u32 RW per.	Modbus 60C _h IDN P-0-3040.0.5
P5-08 POSLIMPOS	Positive Software Limit Switch - Position Prerequisite: Software limit switches only work with a valid zero point. Setting can only be modified if power stage is disabled.	PUU -2147483647 134217727 2147483647 Decimal	s32 RW per.	Modbus 610 _h IDN P-0-4005.0.8
P5-09 POSLIMNEG	Negative Software Limit Switch - Position Prerequisite: Software limit switches only work with a valid zero point. Setting can only be modified if power stage is disabled.	PUU -2147483647 -134217727 2147483647 Decimal	s32 RW per.	Modbus 612 _h IDN P-0-4005.0.9
P5-11 POSLIMHYST	Software Limit Switches - Hysteresis Value This parameter specifies a hysteresis value for the software limit switches. Setting can only be modified if power stage is disabled.	PULSE 0 3556 35555 Decimal	u16 RW per.	Modbus 616 _h IDN P-0-3005.2.11
P5-12 PROBE_1_LVL_PRD	Touch Probe Input 1 - Stable Level Duration This parameter specifies the period of time for which the level at Touch Probe input 1 must be stable.	31.25 µs 2 5 32 Decimal	u16 RW per.	Modbus 618 _h IDN P-0-4005.0.12
P5-13 POSLIMMODE	Position Limiting Mode This parameter activates/deactivates the software limit switches and the homing transient limits. Value 0: • Deactivate software limit switches. • Activate homing transient limits. Value 1: • Activate software limit switches. • Activate homing transient limits. Value 2: • Deactivate software limit switches. • Deactivate homing transient limits. Value 3:	- 0 2 3 Decimal	u16 RW per.	Modbus 61A _h IDN P-0-4005.0.13

Parameter name	Description	Unit Minimum value Factory setting Maximum value HMI Format	Data type R/W Persistent	Parameter address via fieldbus
	<ul style="list-style-type: none"> Activate software limit switches. Deactivate homing transient limits. <p>NOTE: Software limit switches only work with a valid zero point.</p>			
P5-14 ICMDSLOPE	<p>Motion Profile for Torque - Slope</p> <p>This parameter specifies the slope of the motion profile for torque.</p>	<p>mA/s</p> <p>1</p> <p>100000</p> <p>30000000</p> <p>Decimal</p>	<p>u32</p> <p>RW</p> <p>per.</p>	<p>Modbus 61C_h</p> <p>IDN P-0-3006.0.42</p>
P5-15 ICMDSLOPEEN	<p>Motion Profile for Torque - Activation</p> <p>This parameter activates the motion profile for torque.</p> <p>Value 0: Deactivate</p> <p>Value 1: Activate</p> <p>Setting can only be modified if power stage is disabled.</p>	<p>-</p> <p>0</p> <p>0</p> <p>1</p> <p>Decimal</p>	<p>u16</p> <p>RW</p> <p>per.</p>	<p>Modbus 61E_h</p> <p>IDN P-0-3006.0.44</p>
P5-16 AXEN	<p>Encoder Increments in PUU</p> <p>Setting can only be modified if power stage is disabled.</p> <p>This parameter specifies an offset to the encoder position.</p>	<p>PUU</p> <p>-2147483647</p> <p>0</p> <p>2147483647</p> <p>Decimal</p>	<p>s32</p> <p>RW</p> <p>-</p>	<p>Modbus 620_h</p> <p>IDN P-0-4005.0.16</p>
P5-18 AXPC	<p>External Encoder (Pulses)</p> <p>This parameter contains the cumulated pluses counted at the PTI input multiplied by 16 since the drive has been switched on.</p>	<p>-</p> <p>-2147483648</p> <p>-</p> <p>2147483647</p> <p>Decimal</p>	<p>s32</p> <p>RO</p> <p>-</p>	<p>Modbus 624_h</p> <p>IDN P-0-4005.0.18</p>
P5-21 CTO	<p>Deceleration Ramp - Detected Transmission Error</p> <p>This parameter specifies the deceleration ramp for a stop triggered if a transmission error is detected.</p> <p>The deceleration period is the time in milliseconds required to decelerate from 6000 rpm to motor standstill. It is used to set the deceleration ramp.</p>	<p>ms</p> <p>6</p> <p>50</p> <p>65500</p> <p>Decimal</p>	<p>u16</p> <p>RW</p> <p>per.</p>	<p>Modbus 62A_h</p> <p>IDN P-0-3005.0.21</p>
P5-22 OVF	<p>Deceleration Ramp - Position Overflow</p> <p>This parameter specifies the deceleration ramp for a stop triggered if a position overflow is detected.</p> <p>The deceleration period is the time in milliseconds required to decelerate from 6000 rpm to motor standstill. It is used to set the deceleration ramp.</p>	<p>ms</p> <p>6</p> <p>30</p> <p>65500</p> <p>Decimal</p>	<p>u16</p> <p>RW</p> <p>per.</p>	<p>Modbus 62C_h</p> <p>IDN P-0-4005.0.22</p>
P5-23 SNL	<p>Deceleration Ramp - Triggering of Negative Software Limit Switch</p> <p>This parameter specifies the deceleration ramp for a stop triggered if the negative software limit switch is activated.</p> <p>The deceleration period is the time in milliseconds required to decelerate from 6000 rpm to motor standstill. It is used to set the deceleration ramp.</p>	<p>ms</p> <p>6</p> <p>50</p> <p>65500</p> <p>Decimal</p>	<p>u16</p> <p>RW</p> <p>per.</p>	<p>Modbus 62E_h</p> <p>IDN P-0-3005.0.23</p>

Parameter name	Description	Unit Minimum value Factory setting Maximum value HMI Format	Data type R/W Persistent	Parameter address via fieldbus
P5-24 SPL	Deceleration Ramp - Triggering of Positive Software Limit Switch This parameter specifies the deceleration ramp for a stop triggered if the positive software limit switch is activated. The deceleration period is the time in milliseconds required to decelerate from 6000 rpm to motor standstill. It is used to set the deceleration ramp.	ms 6 50 65500 Decimal	u16 RW per.	Modbus 630 _h IDN P-0-3005.0.24
P5-25 NL	Deceleration Ramp - Triggering of Negative Hardware Limit Switch This parameter specifies the deceleration ramp for a stop triggered if the negative hardware limit switch is activated. The deceleration period is the time in milliseconds required to decelerate from 6000 rpm to motor standstill. It is used to set the deceleration ramp.	ms 6 30 65500 Decimal	u16 RW per.	Modbus 632 _h IDN P-0-4005.0.25
P5-26 PL	Deceleration Ramp - Triggering of Positive Hardware Limit Switch This parameter specifies the deceleration ramp for a stop triggered if the positive hardware limit switch is activated. The deceleration period is the time in milliseconds required to decelerate from 6000 rpm to motor standstill. It is used to set the deceleration ramp.	ms 6 30 65500 Decimal	u16 RW per.	Modbus 634 _h IDN P-0-4005.0.26
P5-35 PROBES_POLARITY	Touch Probes Polarity This parameter specifies the touch probes polarity.	- 0 - 3 Decimal	u16 RO per.	Modbus 646 _h IDN P-0-4005.0.35
P5-36 CAAX_FIELDBUS	Touch Probe Input 1 - Captured Position SERCOS III Units This parameter contains the position captured at Touch Probe input 1.	Fieldbus PU -2147483647 - 2147483647 Decimal	s32 RO per.	Modbus 648 _h IDN P-0-4005.0.36
P5-37 CAAX	Touch Probe Input 1 - Captured Position This parameter contains the position captured at Touch Probe input 1.	PUU -2147483647 0 2147483647 Decimal	s32 RO -	Modbus 64A _h IDN P-0-4005.0.37
P5-38 PROBE1_CNTR	Touch Probe Input 1 - Event Counter The value is increased by 1 each time a position has been captured at Touch Probe input 1.	- 0 0 65535 Decimal	u16 RO -	Modbus 64C _h IDN P-0-4005.0.38
P5-39 CACT	Touch Probe Input 1 - Configuration X: Activate/deactivate position capture 0: Deactivate	- 0 _h 0 _h	u16 RW -	Modbus 64E _h IDN P-0-4005.0.39

Parameter name	Description	Unit Minimum value Factory setting Maximum value HMI Format	Data type R/W Persistent	Parameter address via fieldbus
	<p>1: Activate (is reset to 0 when the counter in P5-38 is incremented)</p> <p>Y: Reserved</p> <p>U: Reserved</p> <p>Z: Polarity of Touch Probe input</p> <p>0: Normally open</p> <p>1: Normally closed</p> <p>Where X is the least significant half-byte and U is the most significant half-byte of the X/Y/U/Z Integer.</p>	<p>101_h</p> <p>Hexadecimal</p>		
P5-56 CAAX2_FIELDBUS	<p>Touch Probe Input 2 - Captured Position SERCOS III Units</p> <p>This parameter contains the position captured at Touch Probe input 2.</p>	<p>Fieldbus PU</p> <p>-2147483647</p> <p>-</p> <p>2147483647</p> <p>Decimal</p>	<p>s32</p> <p>RO</p> <p>per.</p>	<p>Modbus 670_h</p> <p>IDN P-0-3005.0.56</p>
P5-57 CAAX2	<p>Touch Probe Input 2 - Captured Position</p> <p>This parameter contains the position captured at Touch Probe input 2.</p>	<p>PUU</p> <p>-2147483647</p> <p>0</p> <p>2147483647</p> <p>Decimal</p>	<p>s32</p> <p>RO</p> <p>-</p>	<p>Modbus 672_h</p> <p>IDN P-0-3005.0.57</p>
P5-58 PROBE2_CNTR	<p>Touch Probe Input 2 - Event Counter</p> <p>The value is increased by 1 each time a position has been captured at Touch Probe input 2.</p>	<p>-</p> <p>0</p> <p>0</p> <p>65535</p> <p>Decimal</p>	<p>u16</p> <p>RO</p> <p>-</p>	<p>Modbus 674_h</p> <p>IDN P-0-3005.0.58</p>
P5-59 CACT2	<p>Touch Probe Input 2 - Configuration</p> <p>X: Activate/deactivate position capture</p> <p>0: Deactivate</p> <p>1: Activate (is reset to 0 when the counter in P5-58 is incremented)</p> <p>Y: Reserved</p> <p>Z: Polarity of Touch Probe input</p> <p>0: Normally open</p> <p>1: Normally closed</p> <p>U: Reserved</p>	<p>-</p> <p>0_h</p> <p>0_h</p> <p>101_h</p> <p>Hexadecimal</p>	<p>u16</p> <p>RW</p> <p>-</p>	<p>Modbus 676_h</p> <p>IDN P-0-3005.0.59</p>
P5-76 HOME_OFFSET_MOVE	<p>Move Home Offset When Homing</p> <p>This parameter activate/deactivate a movement to a configured home offset position when the homing position is reached.</p>	<p>-</p> <p>0</p> <p>0</p> <p>1</p> <p>Decimal</p>	<p>u16</p> <p>RW</p> <p>per.</p>	<p>Modbus 698_h</p> <p>IDN P-0-3005.0.76</p>
P5-77	Touch Probe Input 2 - Stable Level Duration	<p>31.25 µs</p> <p>2</p>	<p>u16</p> <p>RW</p>	<p>Modbus 69A_h</p> <p>IDN P-0-3005.0.77</p>

Parameter name	Description	Unit Minimum value Factory setting Maximum value HMI Format	Data type R/W Persistent	Parameter address via fieldbus
PROBE_2_LVL_PRD	This parameter specifies the period of time for which the level at Touch Probe input 2 must be stable.	5 32 Decimal	per.	
P5-78 MT_Ref_P	MULTI_TURN_REF_POSITION After a successful reference set (P8-44=2), this P5-78 position is automatically set at the reference point.	PUU -2147483647 0 2147483647 Decimal	s32 RW per.	Modbus 69C _h IDN P-0-3005.0.78
P5-79 IGNORE_BATTERY_FAULTS	Defines whether the drive is to ignore the multi-turn error AL576: <ul style="list-style-type: none"> 0: The masking of the multi-turn error AL576 is inactive. 1: The masking of the multi-turn error AL576 is active. When set P5-79=1, multi-turn encoder can be used as single-turn (even with single-turn cable).	- 0 0 1 Decimal	u16 RW per.	Modbus 69E _h IDN P-0-3005.0.79
P5-80 IGNORE_ENCODER_WARNINGS	Defines whether the drive is to ignore the multi-turn alert Wn750. <ul style="list-style-type: none"> 0: The masking of the Wn750 is inactive. 1: The masking of the Wn750 is active. For some applications which will rotate motor in one direction, the alert Wn750 for checking turns number within -32767 ... 32768 can be turned off by parameter P5-80=1.	- 0 0 1 Decimal	u16 RW per.	Modbus 6A0 _h IDN P-0-3005.0.80
P5-81 IgnorHome	IGNORE_HOMING_REF_POS Defines whether absolute positioning is allowed without homing/Reference Position Set. <ul style="list-style-type: none"> 0: Not allowed 1: Allowed When set P5-81=1, absolute positioning is allowed without homing/set Reference Point.	- 0 0 1 Decimal	u16 RW per.	Modbus 6A2 _h IDN P-0-3005.0.81
P5-82 MT_C_P	Current position in revolutions This parameter is used to monitor the revolutions of multi-turn.	Rev -32767 0 32768 Decimal	s32 RO per.	Modbus 6A4 _h IDN P-0-3005.0.82

P8 - Control Loops

P8 - Control Loops

Parameter name	Description	Unit Minimum value Factory setting Maximum value HMI Format	Data type R/W Persistent	Parameter address via fieldbus
P8-00 LTND	Derivative Gain This parameter is used to adjust the derivative gain. Refer to chapter Manual Tuning, page 156.	0.1Hz 0 800 20000 Decimal	u32 RW per.	Modbus 900 _h IDN P-0-3008.0.0
P8-01 LTNI	Integral Gain This parameter is used to adjust the integral gain. Refer to chapter Manual Tuning, page 156.	0.1Hz 0 100 2000 Decimal	u32 RW per.	Modbus 902 _h IDN P-0-3008.1.1
P8-02 LTNIV	Derivative-Integral Gain This parameter is used to adjust the derivative-integral gain. Refer to chapter Manual Tuning, page 156.	0.1Hz 0 400 4000 Decimal	u32 RW per.	Modbus 904 _h IDN P-0-3008.0.2
P8-03 LTNP	Proportional Gain This parameter is used to adjust the proportional gain. Refer to chapter Manual Tuning, page 156.	0.1Hz 0 300 4000 Decimal	u32 RW per.	Modbus 906 _h IDN P-0-3008.0.3
P8-04 LTNUSERGAIN	Global Gain	0.001 100 500 3000 Decimal	u32 RW per.	Modbus 908 _h IDN P-0-3008.0.4
P8-05 NLAFFLPPHZ	LTN Spring Filter This parameter is used to set a low-pass filter for the acceleration profile during tuning. Refer to chapter Manual Tuning, page 156.	Hz 10 7000 7000 Decimal	u16 RW per.	Modbus 90A _h IDN P-0-3008.0.5
P8-06 NLANTIVIBGAIN	Anti-Vibration Gain	Rad*10 ⁻³ /N 0 0 10000 Decimal	u32 RW per.	Modbus 90C _h IDN P-0-3008.0.6
P8-07	Pe filter	0.001	u32	Modbus 90E _h

Parameter name	Description	Unit Minimum value Factory setting Maximum value HMI Format	Data type R/W Persistent	Parameter address via fieldbus
NLANTIVIBGAIN2	This parameter is used to set the gain of the Pe filter.	0 0 99000 Decimal	RW per.	IDN P-0-3008.0.7
<i>P8-08</i> NLANTIVIBHZ	Anti-Vibration Filter This parameter is used to set the frequency to remove while using the anti-vibration filter.	0.1Hz 50 4000 4000 Decimal	u32 RW per.	Modbus 910 _h IDN P-0-3008.0.8
<i>P8-09</i> NLANTIVIBHZ2	Pe filter This parameter is used to set the frequency to remove with the Pe filter.	0.1Hz 50 4000 8000 Decimal	u32 RW per.	Modbus 912 _h IDN P-0-3008.0.9
<i>P8-10</i> NLANTIVIBLMJR	Ratio of Load Inertia to Motor Inertia for Anti-Vibration Expert parameter for the internal control loop.	0.1 0 0 6000 Decimal	u32 RW per.	Modbus 914 _h IDN P-0-4008.0.10
<i>P8-11</i> NLANTIVIBN	NL Anti-Resonance Filter Divider Expert parameter for the internal control loop.	0.01 1 200 10000 Decimal	u32 RW per.	Modbus 916 _h IDN P-0-4008.0.11
<i>P8-12</i> NLANTIVIBSHARP	Anti-Resonance Sharpness Expert parameter for the internal control loop.	0.001 10 500 10000 Decimal	u16 RW per.	Modbus 918 _h IDN P-0-4008.0.12
<i>P8-13</i> NLANTIVIBSHARP2	Pe Sharpness This parameter is used to optimize the Pe filter action.	0.001 10 500 10000 Decimal	u16 RW per.	Modbus 91A _h IDN P-0-4008.0.13
<i>P8-14</i> NLFILTDAMPING	Current Filter Damping For further details, refer to Manual Tuning, page 156.	% 0 0 100 Decimal	u16 RW per.	Modbus 91C _h IDN P-0-3008.0.14
<i>P8-15</i>	Current Filter Low Pass Filter Rise Time	0.01ms	u16	Modbus 91E _h

Parameter name	Description	Unit Minimum value Factory setting Maximum value HMI Format	Data type R/W Persistent	Parameter address via fieldbus
NLFILTT1	For further details, refer to Manual Tuning, page 156.	0 300 3000 Decimal	RW per.	IDN P-0-3008.1.15
<i>P8-16</i> NLNOTCH2BW	Current Filter - Second Notch Filter Bandwidth	Hz 0 0 500 Decimal	u16 RW per.	Modbus 920 _h IDN P-0-3008.1.16
<i>P8-17</i> NLNOTCH2CENTER	Current Filter - Second Notch Filter Center	Hz 5 100 1800 Decimal	u16 RW per.	Modbus 922 _h IDN P-0-3008.1.17
<i>P8-18</i> NLNOTCHBW	Current Filter - Notch Filter Bandwidth	Hz 0 0 500 Decimal	u16 RW per.	Modbus 924 _h IDN P-0-4008.0.18
<i>P8-19</i> NLNOTCHCENTER	Current Filter - Notch Filter Center For further details, refer to Manual Tuning, page 156.	Hz 5 100 1800 Decimal	u16 RW per.	Modbus 926 _h IDN P-0-4008.0.19
<i>P8-20</i> NLPEAFF	Elasticity Compensation This parameter is used in the compensation of the elasticity of the mechanical system. For further details, refer to Manual Tuning, page 156.	0.1Hz 0 50000 50000 Decimal	u32 RW per.	Modbus 928 _h IDN P-0-3008.0.20
<i>P8-21</i> NLPEDFFRATIO	Spring Deceleration Ratio This parameter is used in the compensation of the elasticity of the mechanical system. For further details, refer to Manual Tuning, page 156.	0.001 0 1000 2000 Decimal	u16 RW per.	Modbus 92A _h IDN P-0-3008.0.21
<i>P8-32</i> MOVESMOOTHAVG	S-Curve Setting Setting can only be modified if power stage is disabled. The maximum value is reduced to 12800 if <i>P8-35</i> CONTROLMODE (high byte) is set to 5.	0.01ms 25 400 25600 Decimal	u32 RW per.	Modbus 940 _h IDN P-0-4008.0.32
<i>P8-33</i>	Low Pass Filter Setting for Profile Position	0.01 HZ HZ	u32	Modbus 942 _h

Parameter name	Description	Unit Minimum value Factory setting Maximum value HMI Format	Data type R/W Persistent	Parameter address via fieldbus
MOVE-SMOOTHLPPHZ	The unit is modified to 0.01Hz if P2-65 GBIT Bit 14 is set to 1.	100 1 500000 5000 500000 5000 Decimal	RW per.	IDN P-0-4008.0.33
P8-34 MOVESMOOTH-MODE	Smoothing Filter for Profile Position Value 0: No smoothing Value 1: LPF smoothing Value 2: S-curve smoothing Setting can only be modified if power stage is disabled.	- 0 2 2 Decimal	u16 RW per.	Modbus 944 _h IDN P-0-4008.0.34
P8-35 CONTROLMODE	Type of Velocity Control Type of Position Control This parameter specifies: <ul style="list-style-type: none"> the position control mode (high byte) <ul style="list-style-type: none"> value 2: Position control mode 2 (Sample rate 4 kHz) value 5: Position control mode 5 (Sample rate 8 kHz) value 40: Linear position control the type of velocity (low byte) <ul style="list-style-type: none"> value 1: Linear velocity control value 5: Velocity control with integral gain (P8-01, P8-02) value 6: Velocity control without integral gain value 7: Velocity control with P8-00 = P8-01, P8-02 = 0, P8-03 = 0 Setting can only be modified if power stage is disabled.	- 5 _h 207 _h 4001 _h Hexadecimal	u16 RW per.	Modbus 946 _h IDN P-0-4008.0.35
P8-36 NLANTIVIBGAIN3	Pe filter 3 This parameter is used to set the gain of the Pe filter 3	0.001 0 0 6000 Decimal	u32 RW per.	Modbus 948 _h IDN P-0-4008.0.36
P8-37 NLANTIVIBHZ3	Pe filter 3 This parameter is used to set the frequency to remove with the Pe filter 3.	0.1Hz 50 4000 8000 Decimal	u32 RW per.	Modbus 94A _h IDN P-0-4008.0.37
P8-38 NLANTIVIBQ3	Pe filter 3 This parameter is used to set the zero-pole alignment with the Pe filter 3.	0.001 200 1000 10000 Decimal	u32 RW per.	Modbus 94C _h IDN P-0-4008.0.38
P8-39 IGRAV	Gravity Compensation This parameter is used to set the gravity compensation current for unbalanced systems.	0.01A -	s16 RW	Modbus 94E _h IDN P-0-3008.0.39

Parameter name	Description	Unit Minimum value Factory setting Maximum value HMI Format	Data type R/W Persistent	Parameter address via fieldbus
		0 - Decimal	per.	
<i>P8-40</i> LTNAFRC	LTN AFF This parameter is used to set the feed-forward term for the current command.	- 0 0 200 Decimal	u16 RW per.	Modbus 950 _h IDN P-0-3008.0.40
<i>P8-41</i> NLANTIVIBSHARP3	Pe Sharpness This parameter is used to optimize the Pe filter 3 action.	- 10 200 10000 Decimal	u16 RW per.	Modbus 952 _h IDN P-0-3008.0.41
<i>P8-42</i> HOME_FAILURE_IND	Homing Error Information This parameter provides information in case of the homing is not successful.	- 0 - FFFFFFFF _h Hexadecimal	u32 RO -	Modbus 954 _h IDN P-0-3008.0.42
<i>P8-43</i> ZSPDLPFHZ	ZSPD Low Pass Filter Value This parameter sets the low pass filter value for ZSPD output in order to reduce jitters when the motor speed is around the Zero speed Threshold (P1-38) value.	Hz 10 1000 1000 Decimal	u16 RW per.	Modbus 956 _h IDN P-0-3008.0.43
<i>P8-44</i> MT_COMMANDS	Send commands to multi-turn encoder Value 0: No command to send. Value 1: Clear the battery detected error AL576 on the encoder. Value 2: To set an encoder reference position. Clear Wn753. This command can be performed in both (enable and disable) drive states, excluding CSP mode. Value 3: Reset the number of accumulated revolutions of the encoder to zero. Clear Wn750. The drive must be disabled.	- 0 - 3 Decimal	u16 RW -	Modbus 958 _h IDN P-0-3008.0.44
<i>P8-45</i> FEEDBACKTYPE	Feedback type Value 0: No feedback connected or undetermined feedback connected. Value 1: Single-turn encoder. Value 2: Multi-turn encoder.	- 0 - 2 Decimal	u16 RO -	Modbus 95A _h IDN P-0-3008.0.45
<i>P8-46</i> SRVSNS_TEMPERATURE	Encoder temperature	Deg. - - -	s16 RO -	Modbus 95C _h IDN P-0-3008.0.46

Parameter name	Description	Unit Minimum value Factory setting Maximum value HMI Format	Data type R/W Persistent	Parameter address via fieldbus
		Decimal		
P8-47 SRVSNS_VER	Encoder firmware and hardware versions The format is: ZZaabbcc <ul style="list-style-type: none"> aa.bb.cc: firmware version. ZZ: hardware version. 	- - - 4294967295 Decimal	u32 RO -	Modbus 95E _h IDN P-0-3008.0.47
P8-48 SRVSNS_FLTS	Encoder errors <ul style="list-style-type: none"> Bit 0: The returned position values are no longer considered as reliable. Bit 1: The device temperature is too high. Bit 2: The device temperature is too low. Bit 3: The device is not calibrated or the calibration data is corrupted. The device is not able to decode the position. Bit 4: The device supply voltage has dropped under operational value. Bit 5: The multi-turn encoder battery voltage has dropped under 3 Vdc. Bit 6: The multi-turn encoder requires an explicit configuration command. Bit 7: Internal position synchronization error detected between the multi-turn and the single-turn modules. Bit 8: Generic error code of the multi-turn module is detected. Bit 16...23: Internal Error detected. Bit 24: The encoder firmware cannot operate on the provided hardware. Bit 25...31: Reserved. 	- - - 4294967295 Hexadecimal	u32 RO -	Modbus 960 _h IDN P-0-3008.0.48
P8-49 SRVSNS_WRNS	Encoder alerts <ul style="list-style-type: none"> Bit 0: The device temperature is too high. Bit 1: The device temperature is too low. Bit 2: Over speed. Bit 3: Over acceleration. Bit 4: Invalid checksum value detected on non-volatile memory initialization. Bit 5: non-volatile memory is empty. Bit 6: Internal Parameters area detected as invalid, default values are used. Bit 7: Invalid decoding sequence detected. Bit 8: Encoder internal flash error detected. Bit 9: The device has detected unusual high shaft displacement. Position error might be greater than usual. Bit 10: The multi-turn encoder battery voltage is in the range 3000 ... 3150 mVdc. Bit 11: Reserved. Bit 12: The multi-turn encoder counter exceeded the range of signed 16 bit value (-32767 ... 32768). The alert remains active until MT_COMMANDS (P8-44) is set to 2. The multi-turn encoder counter continues to count in the range 0 ... 65535. Bit 13...31: Reserved. 	- - - 4294967295 Hexadecimal	u32 RO -	Modbus 962 _h IDN P-0-3008.0.49
P8-51	Speed Observer Mode	-	u16	Modbus 966 _h

Parameter name	Description	Unit	Data type	Parameter address via fieldbus
		Minimum value Factory setting Maximum value HMI Format	R/W Persistent	
SPDOBSRVRMODE	Value 0: Speed feedback value is computed by the drive. Value 3: Speed feedback value is measured by the encoder.	0 0 3 Decimal	RW per.	IDN P-0-3008.0.51
P8-53 KPP	Position Linear Controller Proportional Gain This parameter sets the value of the proportional gain for the linear position controller. NOTE: After motor connection, the drive automatically sets the optimized value, page 214.	0.1 rps/rev 0 300 12000 Decimal	u16 RW per.	Modbus 96A _h IDN P-0-3008.0.53
P8-54 KPVFR	Position Velocity Feedforward This parameter sets the value of the position velocity feedforward to velocity command gain for the linear position controller. This is used to reduce the position following error at constant speed. NOTE: Value of 1000 is the nominal design for zero position following error.	0.001 -2000 500 2000 Decimal	s32 RW per.	Modbus 96C _h IDN P-0-3008.0.54
P8-55 KPAFVRV	Position Acceleration Feedforward This parameter sets the value of the position acceleration feedforward to velocity command gain for the linear position controller. This is used to reduce the position following error at constant acceleration. NOTE: Value of 1000 is the nominal design for zero position following error.	0.001 -20000 0 20000 Decimal	s32 RW per.	Modbus 96E _h IDN P-0-3008.0.55
P8-56 KPAFRC	Position Acceleration Feedforward to Current Loop This parameter sets the value of the position acceleration feedforward to current command gain for the linear position controller. This is used to reduce the position following error at constant acceleration. NOTE: Value of 100 is the nominal design for zero position following error. P1-37 value must be correctly set.	0.001 -20000 0 20000 Decimal	s32 RW per.	Modbus 970 _h IDN P-0-3008.0.56
P8-57 KVP	Velocity Proportional Gain This parameter sets the value of the proportional gain for the linear velocity controller. NOTE: After motor connection, the drive automatically sets the optimized value, page 214.	0.001 0 100 1000000000 Decimal	u32 RW per.	Modbus 972 _h IDN P-0-3008.0.57
P8-58 KVI	Velocity Integral Gain This parameter sets the value of the integral gain for the linear velocity controller. NOTE: After motor connection, the drive automatically sets the optimized value, page 214.	0.001 0 30000 200000000 Decimal	u32 RW per.	Modbus 974 _h IDN P-0-3008.0.58
P8-59 KVFR	Velocity Feedforward Ratio This parameter sets the value of the feedforward ratio for the linear velocity controller.	0.001 0 900	u16 RW per.	Modbus 976 _h IDN P-0-3008.0.59

Parameter name	Description	Unit Minimum value Factory setting Maximum value HMI Format	Data type R/W Persistent	Parameter address via fieldbus
	NOTE: Value of 1000 makes the control close to a PI control. Higher values reduces the following error but introduces an overshoot.	1000 Decimal		
P8-60 FILTMODE	Velocity Loop Output Filter Mode This parameter sets the value of the velocity loop output filter for the linear velocity controller. Value 0: No filtering. Value 1: First order low pass filter; sets P8-61 as corner frequency. Value 2: Double first order low pass filter (sets P8-61 and P8-62 as corner frequencies). Value 3: Notch filter (sets P8-62 as notch center frequency and P8-61 as notch frequency width). NOTE: After motor connection, the drive automatically sets the optimized value, page 214.	- 0 2 3 Decimal	u16 RW per.	Modbus 978 _h IDN P-0-3008.0.60
P8-61 FILTHZ1	Velocity Loop Output Filter Parameter 1 The function of this parameter depends on the velocity loop output filter mode (see P8-60). NOTE: After motor connection, the drive automatically sets the optimized value, page 214.	- 1 500 10000 Decimal	u16 RW per.	Modbus 97A _h IDN P-0-3008.0.61
P8-62 FILTHZ2	Velocity Loop Output Filter Parameter 2 The function of this parameter depends on the velocity loop output filter mode (see P8-60). NOTE: After motor connection, the drive automatically sets the optimized value, page 214.	- 1 500 10000 Decimal	u16 RW per.	Modbus 97C _h IDN P-0-3008.0.62
P8-63 VELFILTMODE	Velocity Filter Mode This parameter sets the value of the type of filter that is used for extraction of a velocity signal from the position feedback. Value 0: No filtering. Use derivative of feedback position. Value 1: First order low pass filter; sets P8-64 as corner frequency. Value 2: Use of the velocity feedback provided by the encoder. Setting can only be modified if power stage is disabled.	- 0 1 2 Decimal	u32 RW per.	Modbus 97E _h IDN P-0-3008.0.63
P8-64 VELFILTRQ	Velocity Filter Pole Frequency This parameter sets the value of the first order filter, which is applied to the velocity feedback signal before applying the velocity controller. NOTE: This parameter value is used only if P8-63 is set to 1. Setting can only be modified if power stage is disabled.	- 20 440 2000 Decimal	u16 RW per.	Modbus 980 _h IDN P-0-3008.0.64
P8-65 IFFLPHZ	Current Feedforward Low Pass Filter This parameter sets the value of the first order filter of the linear controller which is applied to the	- 10 1000	u16 RW per.	Modbus 982 _h IDN P-0-3008.0.65

Parameter name	Description	Unit Minimum value Factory setting Maximum value HMI Format	Data type R/W Persistent	Parameter address via fieldbus
	current feedforward before it is added to current command.	1000 Decimal		
P8-66 NLTFDESIGNMODE	LTN Torque Filter Mode This parameter sets the value of the torque filter mode used in the LTN control loop. Value 0: Manual set of P8-15 and P8-14 values. Value 1: P8-15 and P8-14 values are computed based on P8-67 value.	- 0 0 1 Decimal	u16 RW per.	Modbus 984 _h IDN P-0-3008.0.66
P8-67 NLTFBW	LTN Torque Filter Bandwidth This parameter sets the value of the filter bandwidth used in LTN control loop to define P8-15 and P8-14 values with 10% overshoot.	Hz 50 1000 2000 Decimal	u16 RW per.	Modbus 986 _h IDN P-0-3008.0.67
P8-68 NLNOTCHMODE	Current Filter - Notch Filter Mode This parameter sets the value of the notch filter mode used in the LTN control loop. Value 0: Original notch filter. Value 1: Advanced notch filter.	- 0 0 1 Decimal	u16 RW per.	Modbus 988 _h IDN P-0-3008.0.68
P8-69 STANDSTILLMODE	Standstill Mode This parameter sets the value of the standstill mode used for variable gain. The drive latches the variable gain when the motor is at standstill. Value 0: The drive revert to the original gain when the motor is not at standstill. Value 1: The drive revert to the original gain when a new motion command is applied. NOTE: The motor is at standstill when: <ul style="list-style-type: none"> the velocity command is less than the velocity value set via the parameter P1-38 and the position deviation is within the tolerance sets via the parameter P1-54. 	- 0 0 1 Decimal	u16 RW per.	Modbus 98A _h IDN P-0-3008.0.69
P8-70 STANDSTILLGAIN	Standstill Gain This parameter sets the value of the variable gain used for the linear position controller. When the motor is at standstill, the velocity proportional gain (P8-57 KVP) and the position proportional gain (P8-53 KPP) are multiplied by (P8-70/1024).When the motor is not at standstill, the velocity proportional gain and the position proportional gain revert to their original values.	- 128 1024 1024 Decimal	u16 RW per.	Modbus 98C _h IDN P-0-3008.0.70
P8-71 SFILTMODE	Encoder Filter Mode This parameter activates/deactivates the encoder filter. Value 0: Deactivate the encoder filter. Value 1: Activate the encoder filter.	- 0 0 1 Decimal	s16 RW per.	Modbus 98E _h IDN P-0-3008.0.71

Parameter name	Description	Unit Minimum value Factory setting Maximum value HMI Format	Data type R/W Persistent	Parameter address via fieldbus
	The encoder filter helps to reduce the feedback jitter.			
P8-71 SFILTMODE	Encoder Filter Mode This parameter activates/deactivates the encoder filter. Value 0: Deactivate the encoder filter. Value 1: Activate the encoder filter. The encoder filter helps to reduce the feedback jitter.	- 0 0 1 Decimal	s16 RW per.	Modbus 98E _h IDN P-0-3008.0.71
P8-72 HWTEMPHRESH	HW Temperature failure threshold. If HWTEMPHRESH = 0, AL561 will be disabled.	- 0 2000 32767 Decimal	u16 RW	Modbus 990 _h IDN P-0-3008.0.71
P8-99 LTNUSERVCMGDG-AIN	Adaptive Velocity Reference Value Gain	0.001 0 1000 3000 Decimal	u32 RW per.	Modbus 9C6 _h IDN P-0-3008.0.99

Linear Default Gains Values

The following table displays the optimized values set according to the connected motor:

Motor references	P8-53 KPP	P8-57 KVP	P8-58 KVI	P8-60 FILTMODE	P8-61 FILTHZ1	P8-62 FILTHZ2
BCH2MBA53...5C	55	0.4	50	0	0	0
BCH2MB013...5C	25	0.25	50	1	500	0
BCH2LD023...5C	35	0.5	30	1	800	0
BCH2MM031...6C	19	4.5	20	2	400	500
BCH2LD043...5C	30	1.1	25	1	1000	0
BCH2LF043...5C	35	2	50	1	700	0
BCH2MM052...6C	18	8	30	2	500	500
BCH2MM061...6C	20	5	30	1	400	0
BCH2HF073...5C	25	4	30	1	400	0
BCH2LF073...5C	30	3	50	1	500	0
BCH2MM081...6C	23	12	35	2	400	400
BCH2MM091...6C	25	7	35	1	300	0
BCH2MM102...6C	16	8.5	50	1	200	0
BCH2HM102...6C	16	8.5	50	1	200	0
BCH2LH103...6C	23	7	40	1	700	0

Motor references	P8-53 KPP	P8-57 KVP	P8-58 KVI	P8-60 FILTMODE	P8-61 FILTHZ1	P8-62 FILTHZ2
BCH2MM152***6C	25	8	50	2	500	500
BCH2MM202***6C	17	11	15	2	400	400
BCH2MR202***6C	13	21	25	1	200	0
BCH2HR202***6C	13	21	25	1	200	0
BCH2LH203***6C	21	9	40	1	700	0
BCH2MR301***6C	20	30	25	2	400	400
BCH2MR302***6C	15	33	30	2	300	300
BCH2MR352***6C	22	50	30	1	300	0
BCH2MR451***6C	22	35	30	2	300	400

P9 - DTM Data

P9 - DTM Data

Parameter name	Description	Unit Minimum value Factory setting Maximum value HMI Format	Data type R/W Persistent	Parameter address via fieldbus
P9-00 PRGNR	Lexium program number Reads the program number	- 0 _h 0 _h FFFFFFFF _h Hexadecimal	u32 RO -	Modbus A00 _h IDN P-0-3009.0.0
P9-01 DATE	Firmware Version Date This parameter contains the date of the firmware version.	- 0 _h 0 _h FFFFFFFF _h Hexadecimal	u32 RO -	Modbus A02 _h IDN P-0-3009.0.1
P9-02 MTP_ID	MTP Identification Code	- 0 _h - FFFFFFFF _h Hexadecimal	u16 RO -	Modbus A04 _h IDN P-0-3009.0.2
P9-06 UNAME1	User-Defined Application Name 1 This parameter is provided for a user-defined application name.	- 0 _h 0 _h FFFFFFFF _h Hexadecimal	u32 RW per.	Modbus A0C _h IDN P-0-3009.0.6
P9-07 UNAME2	User-Defined Application Name 2 This parameter is provided for a user-defined application name.	- 0 _h 0 _h FFFFFFFF _h	u32 RW per.	Modbus A0E _h IDN P-0-3009.0.7

Parameter name	Description	Unit Minimum value Factory setting Maximum value HMI Format	Data type R/W Persistent	Parameter address via fieldbus
		Hexadecimal		
P9-08 UNAME3	User-Defined Application Name 3 This parameter is provided for a user-defined application name.	- 0 _h 0 _h FFFFFFFF _h Hexadecimal	u32 RW per.	Modbus A10 _h IDN P-0-3009.0.8
P9-09 UNAME4	User-Defined Application Name 4 This parameter is provided for a user-defined application name.	- 0 _h 0 _h FFFFFFFF _h Hexadecimal	u32 RW per.	Modbus A12 _h IDN P-0-3009.0.9
P9-10 MBWORD	Modbus Word Order This parameter sets the word order for Modbus. Value 0: Order of the bytes: 0 1 2 3 Value 1: Order of the bytes: 2 3 0 1	- 0 0 1 Decimal	u16 RW per.	Modbus A14 _h IDN P-0-3009.0.10
P9-11 SERNUM1	Serial Number Part 1	- 0 _h 0 _h FFFFFFFF _h Hexadecimal	u32 RO -	Modbus A16 _h IDN P-0-3009.0.11
P9-12 SERNUM2	Serial Number Part 2	- 0 _h 0 _h FFFFFFFF _h Hexadecimal	u32 RO -	Modbus A18 _h IDN P-0-3009.0.12
P9-13 SERNUM3	Serial Number Part 3	- 0 _h 0 _h FFFFFFFF _h Hexadecimal	u32 RO -	Modbus A1A _h IDN P-0-3009.0.13
P9-14 SERNUM4	Serial Number Part 4	- 0 _h 0 _h FFFFFFFF _h Hexadecimal	u32 RO -	Modbus A1C _h IDN P-0-3009.0.14
P9-15 LTN	Autotuning Method	- 0 0 6	u16 RW -	Modbus A1E _h IDN P-0-3009.0.15

Parameter name	Description	Unit Minimum value Factory setting Maximum value HMI Format	Data type R/W Persistent	Parameter address via fieldbus
		Decimal		
P9-16 LTNREFERENCE	Autotuning Motion Profile - Type	- 0 0 2 Decimal	u16 RW -	Modbus A20 _h IDN P-0-3009.0.16
P9-17 LTNAVMODE	Anti-vibration tuning mode.	- 0 0 6 Decimal	u16 RW -	Modbus A22 _h IDN P-0-3009.0.17
P9-18 LTNSAVEMODE	Autotuning Results - Save/Discard	- 0 0 3 Decimal	u16 RW -	Modbus A24 _h IDN P-0-3009.0.18
P9-19 LTNNLPEAFF	Autotuning - Elasticity Compensation Filters	- 0 1 1 Decimal	s16 RW -	Modbus A26 _h IDN P-0-3009.0.19
P9-20 LTNCYCLE	Autotuning - Direction of Movement This parameter sets the direction of movement for autotuning. Value 0: Both directions of movement Value 2: One direction of movement	- 0 0 3 Decimal	s16 RW -	Modbus A28 _h IDN P-0-3009.0.20
P9-21 LTNDWELLTIME	Minimum Dwell Time for Detection of Movement Cycle	- 100 200 1000 Decimal	u16 RW -	Modbus A2A _h IDN P-0-3009.0.21
P9-22 LTNLMJR	Autotuning - Automatic Estimation of Ratio of Load Inertia and Motor Inertia	- 0 0 1 Decimal	u16 RW -	Modbus A2C _h IDN P-0-3009.0.22
P9-23 LTNSTIFF	Defines which values will be used for the position command filters. Value 0: Automatic smoothing via S-curve optimization of the value Value 1: Manual smoothing	- 0 0 1	u16 RW -	Modbus A2E _h IDN P-0-3009.0.23

Parameter name	Description	Unit Minimum value Factory setting Maximum value HMI Format	Data type R/W Persistent	Parameter address via fieldbus
		Decimal		
P9-25 LTNREFEN	Autotuning Motion Profile - Activation	- 0 0 1 Decimal	u16 RW -	Modbus A32 _n IDN P-0-3009.0.25
P9-26 PTPOS	Autotuning - Movement Range in Direction 1 This parameter specifies the movement range for autotuning in direction of movement 1. The sign of the value determines the direction of movement: Positive value: Positive direction of movement as set via parameter P1-01 Negative value: Negative direction of movement as set via parameter P1-01 See parameter P9-20 to select one direction of movement or both directions of movement for Comfort Tuning.	PUU -2147483647 0 2147483647 Decimal	s32 RW -	Modbus A34 _n IDN P-0-3009.0.26
P9-27 PTNEG	Autotuning - Movement Range in Direction 2 This parameter specifies the movement range for autotuning in direction of movement 2. The sign of the value determines the direction of movement: Positive value: Positive direction of movement as set via parameter P1-01 Negative value: Negative direction of movement as set via parameter P1-01 See parameter P9-20 to select one direction of movement or both directions of movement for Comfort Tuning.	PUU -2147483647 0 2147483647 Decimal	s32 RW -	Modbus A36 _n IDN P-0-3009.0.27
P9-28 LTNACTIVE	Autotuning Active This parameter indicates whether autotuning is active. Value 0: Autotuning inactive Value 1: Autotuning active	- 0 - 1 Decimal	s16 RO -	Modbus A38 _n IDN P-0-3009.0.28
P9-29 LTNVCRUISE	Autotuning - Velocity Bits 0 ... 15: Velocity for positive direction of movement Bits 16 ... 31: Velocity for negative direction of movement	0.1rpm 0.1rpm - - - Decimal	u32 RW -	Modbus A3A _n IDN P-0-3009.0.29
P9-30 LTNST	Autotuning - Status Value 0: Inactive Value 1: Active Value 2: Successfully completed Values 3 ... 9: Reserved	- 0 - 65535 Decimal	u32 RO -	Modbus A3C _n IDN P-0-3009.0.30

Parameter name	Description	Unit Minimum value Factory setting Maximum value HMI Format	Data type R/W Persistent	Parameter address via fieldbus
	Value 10: Impossible to set P9-15 Value 11: Impossible to set P9-16 Value 12: Impossible to set P9-17 Value 13: Impossible to set P9-18 Value 14: Impossible to set P9-19 Value 15: Impossible to set P9-21 Value 16: Impossible to set P9-22 Value 17: Impossible to set P9-23 Value 18: Impossible to set P9-24 Value 19: Impossible to set P9-25 Value 20: Impossible to set P9-32 Value 21: Impossible to enable the power stage Value 22: Hold is active Value 23: Undetermined motor Values 24 ... 26: Reserved Value 27: Impossible to activate autotuning Value 28: Autotuning did not run successfully Value 29: Reserved Value 30: Low Effort Value 31: AVG Zero Init Value Value 32: Cost factor error detected Value 33: Pos tune user gain modified Value 34: Motor Was Not Recognized Value 35: LTNP Step Updated Value 36: Movement too small Value 37: ICMD Sat. Value 38: Insufficient load estimation time. Value 39: Insufficient acceleration/deceleration (less than 33 % of nominal acc/dec) Value 40: Excessive acceleration/deceleration (more than 90 % of nominal acc/dec)			
<i>P9-30</i> Continued	Value 41: Need for gravity compensation (see P9-35) Value 42: Insufficient velocity (less than 10 % of nominal velocity) Value 43: Insufficient deceleration (less than deceleration ramp DECSTOP) Value 44: Autotuning timeout Value 45: Invalid default values Values ... 49: Reserved Value 50: P9-15 set to 0 Value 51: Power stage disabled during autotuning			

Parameter name	Description	Unit Minimum value Factory setting Maximum value HMI Format	Data type R/W Persistent	Parameter address via fieldbus
	Value 52: Current saturation Value 53: Reserved Value 54: Insufficient excitation for autotuning (poor motion profile: short distance, low acceleration/deceleration, etc.) Value 55: Insufficient tuning effort Value 56: Halt during autotuning Value 57: Undetermined motor Value 58: Motion profile exceeds limits Value 59: Invalid gains during autotuning Value 60: Insufficient movement Value 61: Current limitation during autotuning Value 62: Detected alert during autotuning Values 63 ... 69: Reserved Value 70: Positive distance and negative distance are not equal Value 71: Velocity is too low Value 72: Motion profile is not trapezoidal Value 73: Same sign used for positive and negative movement in bidirectional mode Value 74: Different signs used for positive and negative movement in unidirectional mode Values 75 ... 89: Reserved			
<i>P9-31</i> PTACCDEC	Autotuning - Acceleration and Deceleration Bits 0 ... 15: Acceleration for Autotuning Bits 16 ... 31: Deceleration for Autotuning	ms ms 6 6 6000 6000 65500 65500 Decimal	u32 RW -	Modbus A3E _n IDN P-0-3009.0.31
<i>P9-32</i> LTNADVMODE	Autotune advance mode.	- 0 1 2 Decimal	u16 RW -	Modbus A40 _n IDN P-0-3009.0.32
<i>P9-33</i> LTNEFFORTMAX	Maximum Autotuning Optimization Value Setting can only be modified if power stage is disabled.	0.001 0 - 1000 Decimal	u32 RO -	Modbus A42 _n IDN P-0-3009.0.33
<i>P9-34</i> LTNBAR	Autotuning Progress Bar	- 0 0 100	u16 RO -	Modbus A44 _n IDN P-0-3009.0.34

Parameter name	Description	Unit	Data type	Parameter address via fieldbus
		Minimum value Factory setting Maximum value HMI Format	R/W Persistent	
		Decimal		
P9-35 LTNIGRAV	Autotuning - Gravity Estimation	- 0 0 1 Decimal	u16 RW -	Modbus A46 _h IDN P-0-3009.0.35
P9-36 LTNLAFRC	Set LTNAFRC in Autotune	- 0 0 2 Decimal	s16 RW -	Modbus A48 _h IDN P-0-3009.0.36
P9-37 LTNWARNING	Autotuning - Last Stored Event	- 0 0 65535 Decimal	u32 RO -	Modbus A4A _h IDN P-0-3009.0.37
P9-38 LTNIMPROVEMENT	Mode 2 AT improvement	- 0 0 100 Decimal	u16 RO -	Modbus A4C _h IDN P-0-3009.0.38
P9-39 LTNCYCLEIDENT	Cycle Identification status	- 0 0 9 Decimal	u16 RO -	Modbus A4E _h IDN P-0-3009.0.39
P9-40 LTNDEFAULTS	LTN Autotuning Using Defaults	- 0 0 1 Decimal	u16 RW -	Modbus A50 _h IDN P-0-3009.0.40

Operation

What's in This Part

Operation	223
Operating Modes	236

Operation

What's in This Chapter

Access Channels	223
Operating States	224
Setting the Digital Signal Inputs	225
Setting the Digital Signal Outputs	226
Functions for Target Value Processing	228
Setting a Signal Output Via Parameter	229
Forcing the Digital Signal Inputs and Signal Outputs	229
Position Capture via Signal Input	231

Access Channels

The product can be accessed via different types of access channels. Simultaneous access via multiple access channels or the use of exclusive access may cause unintended equipment operation.

⚠ WARNING
<p>UNINTENDED EQUIPMENT OPERATION</p> <ul style="list-style-type: none"> • Verify that simultaneous access via multiple access channels cannot cause unintended triggering or blocking of commands. • Verify that the use of exclusive access cannot cause unintended triggering or blocking of commands. • Verify that the required access channels are available. <p>Failure to follow these instructions can result in death, serious injury, or equipment damage.</p>

The product can be addressed via different access channels.

Access channels are:

- Integrated HMI
- Digital input signals
- Fieldbus
- Commissioning software LXM28 DTM Library

The product allows you to work with exclusive access which limits access to the product via a single access channel.

Only one access channel can have exclusive access to the product.

Exclusive access can be provided via different access channels:

- Via the integrated HMI:
The operating mode Jog or Autotuning can be started via the HMI.
- Via a fieldbus:
Exclusive access is provided to a fieldbus by blocking the other access channels with the parameter *AccessLock*.
- Via the commissioning software LXM28 DTM Library:
The commissioning software receives exclusive access via the switch *Exclusive access* in position *On*.

When the product is powered on, there is no exclusive access via an access channel.

The signal inputs of the safety function STO and the signal input functions **SON** (falling edge), **CWL(NL)** and **CCWL(PL)** are always effective during exclusive access.

Operating States

State Diagram

When the product is powered on and when an operating mode is started, page 236, the product goes through a number of operating states.

The state diagram (state machine) shows the relationships between the operating states and the state transitions.

The operating states are internally monitored and influenced by monitoring functions.

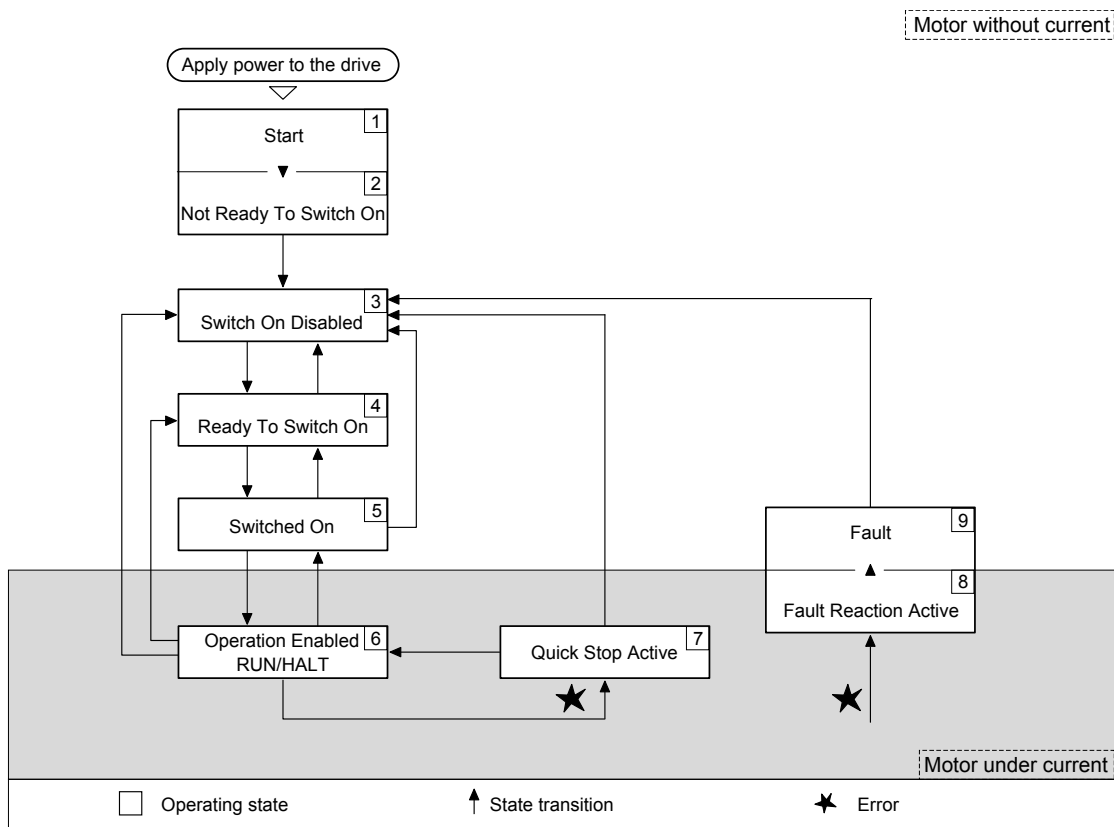

Operating States

Operating state	Description
1 Start	Electronics are initialized
2 Not Ready To Switch On	The power stage is not ready to switch on
3 Switch On Disabled	Impossible to enable the power stage
4 Ready To Switch On	The power stage is ready to switch on.
5 Switched On	Power stage is switched on
6 Operation Enabled	Power stage is enabled Selected operating mode is active
7 Quick Stop Active	Quick Stop is being executed
8 Fault Reaction Active	Error response is active
9 Fault	Error response terminated Power stage is disabled

Resetting an Error Message

After you have removed the cause of the error, you can reset the error message in one of the following ways:

- With a rising edge of the signal input function **SON**
- By using the **Fault Reset** button in the SoMove commissioning software.

Setting the Digital Signal Inputs

Various signal functions can be assigned to the digital signal inputs.

The functions of the inputs and outputs depend on the selected operating mode and the settings of the corresponding parameters.

⚠ WARNING
UNINTENDED EQUIPMENT OPERATION
<ul style="list-style-type: none"> • Only start the system if there are no persons or obstructions in the zone of operation. • Verify that the wiring is appropriate for the settings. • Carefully run tests for all operating states and potential error situations when commissioning, upgrading or otherwise modifying the operation of the drive.
Failure to follow these instructions can result in death, serious injury, or equipment damage.

Default Presets of the Signal Inputs

The following table shows the default presets of the digital signal inputs:

Setting A for P2-10 ... P2-17	Short name	Name	Digital inputs preset
03 _h	GAINUP	Increase Gain	-
1C _h	TPROB1	Touch Probe 1	-
1D _h	TPROB2	Touch Probe 2	-
21 _h	OPST	Stop and Disable Power Stage	DI8
22 _h	CWL(NL)	Negative Limit Switch (NL/LIMN)	DI6
23 _h	CCWL(PL)	Positive Limit Switch (PL/LIMP)	DI7
24 _h	ORGP	Reference Switch	DI5

Parameterization of the Signal Input Functions

The signal input functions for the inputs DI1 ... DI8 are configured via parameters P2-10 ... P2-17.

A signal input function can only be assigned to one of the signal inputs.

The following table provides an overview of the possible signal input functions:

Setting A for P2-10 ... P2-17	Short name	Name	Description
03 _h	GAINUP	Increase Gain	The signal input function GAINUP increases the control gain according to the values and conditions set via parameter P2-27.
1C _h	TPROB1	Touch Probe 1	The signal input function TPROB1 is used to trigger the Position Capture function. This input function can only be assigned to the digital input DI7. Refer to parameters P5-37...P5-39 for additional information.
1D _h	TPROB2	Touch Probe 2	The signal input function TPROB2 is used to trigger the Position Capture function. This input function can only be assigned to the digital input DI6. Refer to parameters P5-57...P5-59 for additional information.
21 _h	OPST	Stop and Disable Power Stage	The signal input function OPST stops the motor with the deceleration ramp set via the parameter P1-68 and then disables the power stage.
22 _h	CWL(NL)	Negative Limit Switch (NL/LIMN)	Negative limit switch (NL/LIMN). When the signal input is activated, an alert is triggered. The deceleration ramp is specified via parameter P5-25.
23 _h	CCWL(PL)	Positive Limit Switch (PL/LIMP)	Positive limit switch (PL/LIMP). When the signal input is activated, an alert is triggered. The deceleration ramp is specified via parameter P5-26.
24 _h	ORGP	Reference Switch	The signal input function ORGP is used for the reference switch.

Setting the Digital Signal Outputs

Various signal functions can be assigned to the digital signal outputs.

The functions of the inputs and outputs depend on the selected operating mode and the settings of the corresponding parameters.

⚠ WARNING

UNINTENDED EQUIPMENT OPERATION

- Only start the system if there are no persons or obstructions in the zone of operation.
- Verify that the wiring is appropriate for the settings.
- Carefully run tests for all operating states and potential error situations when commissioning, upgrading or otherwise modifying the operation of the drive.

Failure to follow these instructions can result in death, serious injury, or equipment damage.

Default Presets of the Signal Outputs

The following table shows the default presets of the digital signal outputs:

Setting A for P2-18 ... P2-21	Short name	Name	Digital outputs presets
01 _h	SRDY	Servo Ready	DO1
02 _h	SON	Servo On	-
03 _h	ZSPD	Zero Speed	-
04 _h	TSPD	Speed Reached	-
05 _h	TPOS	Movement Completed	-
06 _h	TQL	Torque Limit Reached	-
07 _h	ERROR	Error Detected	-
08 _h	BRKR	Holding Brake Control	-
09 _h	HOMED_OK	Homing Completed	-

Setting A for P2-18 ... P2-21	Short name	Name	Digital outputs presets
10 _h	OLW	Motor Overload Alert	-
11 _h	WARN	Alert Signal activated	-
12 _h	OVF	Position command overflow	-
13 _h	SCWL(SNL)	Negative Software Limit Switch Reached	-
14 _h	SCCWL(SPL)	Positive Software Limit Switch Reached	-
15 _h	CMD_OK	Internal position command completed	-
16 _h	CAP_1_OK	Capture 1 completed	-
17 _h	-	-	-
18 _h	CAP_2_OK	Capture 2 completed	-
19 _h ... 2F _h	-	-	-
30 _h	SDO_0	Output the status of bit 0 of P4-06.	-
31 _h	SDO_1	Output the status of bit 1 of P4-06.	-
32 _h	SDO_2	Output the status of bit 2 of P4-06.	-
33 _h	SDO_3	Output the status of bit 3 of P4-06.	-
34 _h ... 3F _h	-	-	-

Parameterization of the Signal Output Functions

The signal output functions for the outputs DO1 ... DO4 are configured via parameters *P2-18* ... *P2-21*.

The following table provides an overview of the possible signal output functions:

Setting A for P2-18 ... P2-21	Short name	Name	Description
01 _h	SRDY	Servo Ready	The signal output function SRDY indicates that no errors are present, that is, the drive is not in the operating state Fault.
02 _h	SON	Servo On	The signal output function SON indicates that the drive is in the operating state Operation Enabled .
03 _h	ZSPD	Zero Speed	The signal output function ZSPD indicates that the velocity of the motor is less than the velocity value set via parameter <i>P1-38</i> .
04 _h	TSPD	Speed Reached	The signal output function TSPD indicates that the velocity of the motor is greater than the velocity value set via parameter <i>P1-39</i> .
05 _h	TPOS	Movement Completed	The signal output function TPOS indicates that the position deviation at the target position is within the tolerance set via the parameter <i>P1-54</i> .
06 _h	TQL	Torque Limit Reached	The signal output function TQL indicates that the torque of the motor has reached the value set via parameters <i>P1-12</i> ... <i>P1-14</i> .
07 _h	ERROR	Error Detected	The signal output function ERROR indicates that an error has been detected and that the drive has switched to the operating state Fault.
08 _h	BRKR	Holding Brake Control	The signal output function BRKR is used to control the holding brake with the settings made via parameters <i>P1-42</i> and <i>P1-19</i> . The holding brake must be connected to the output to which the signal output function BRKR is assigned.
09 _h	HOMED_OK	Homing Completed	The signal output function HOMED_OK indicates that the homing procedure has been successfully completed. The settings for Homing are specified via parameters <i>P5-04</i> ... <i>P5-06</i> .
10 _h	OLW	Motor Overload Alert	The signal output function OLW indicates a motor overload condition. A threshold for the signal output function OLW can be set via parameter <i>P1-28</i> .
11 _h	WARN	Alert Signal activated	The signal output function indicates that one of the following conditions has been detected: Hardware limit switch triggered, undervoltage, Nodeguard alert, Operational Stop (OPST).
12 _h	-	-	Reserved

Setting A for P2-18 ... P2-21	Short name	Name	Description
13 _h	SCWL(SNL)	Negative Software Limit Switch Reached	The signal output function SCWL(SNL) indicates that the negative software limit switch set via parameter P5-09 has been reached. When the software limit switch is reached, an alert is triggered. The deceleration ramp is specified via parameter P5-23.
14 _h	SCCWL (SPL)	Positive Software Limit Switch Reached	The signal output function SCCWL(SPL) indicates that the positive software limit switch set via parameter P5-08 has been reached. When the software limit switch is reached, an alert is triggered. The deceleration ramp is specified via parameter P5-24.
15 _h	CMD_OK	Internal position command completed	The signal output function CMD_OK indicates that the Internal position process has been successfully completed.
16 _h	CAP_1_OK	Capture 1 completed	The signal output function CAP_1_OK indicates that a position capture (Touch Probe 1) has been successfully completed. The settings for position capture (Touch Probe 1) are specified via parameters P5-37 ... P5-39.
17 _h	-	-	Reserved
18 _h	CAP_2_OK	Capture 2 completed	The signal output function CAP_2_OK indicates that a position capture (Touch Probe 2) has been successfully completed. The settings for position capture (Touch Probe 2) are specified via parameters P5-57 ... P5-59.
19 _h ...2F _h	-	-	Reserved
30 _h	SDO_0	Output the status of bit 0 of P4-06.	The signal output functions SDO_0 ... SDO_3 provide the bit pattern (bits 0 ... 3) required to determine the setting of the parameter P4-06.
31 _h	SDO_1	Output the status of bit 1 of P4-06.	The signal output functions SDO_0 ... SDO_3 provide the bit pattern (bits 0 ... 3) required to determine the setting of the parameter P4-06.
32 _h	SDO_2	Output the status of bit 2 of P4-06.	The signal output functions SDO_0 ... SDO_3 provide the bit pattern (bits 0 ... 3) required to determine the setting of the parameter P4-06.
33 _h	SDO_3	Output the status of bit 3 of P4-06.	The signal output functions SDO_0 ... SDO_3 provide the bit pattern (bits 0 ... 3) required to determine the setting of the parameter P4-06.
34 _h ... 3F _h	-	-	Reserved

Functions for Target Value Processing

Stopping a Movement with OPST

With the signal input function OPST (Operational Stop), the ongoing movement is stopped.

In order to stop a movement via a signal input, you must first parameterize the signal input function OPST, refer to *Setting the Digital Signal Inputs*, page 225.

The movement is interrupted via a deceleration ramp to the point of the defined standstill. After that, the power stage is disabled once the drive has determined that the motor is at standstill, and if so configured, the holding brake is applied.

▲ WARNING

UNINTENDED EQUIPMENT OPERATION

- During commissioning, trigger all signals and simulate all conditions that cause a power stage disable request in order to verify that all loads come to a secure standstill when the power stage is disabled under maximum load conditions.
- Install a dedicated service brake if removal of power to the motor does not meet the requirements of your application.

Failure to follow these instructions can result in death, serious injury, or equipment damage.

An error, AL013, is detected and presented.

The deceleration ramp is specified via parameter *P1-68*.

After the OPST function is enabled, you must disable it and re-enable the power stage for continued operation.

Setting a Signal Output Via Parameter

The digital signal outputs can be set via a parameter.

In order to set a digital signal output via the parameter, you must first parameterize the signal output functions SDO_0 ... SDO_3, refer to *Setting the Digital Signal Outputs*, page 226.

The parameter *P4-06* lets you set the digital signal outputs.

Parameter name	Description	Unit Minimum value Factory setting Maximum value HMI Format	Data type R/W Persistent	Parameter address via fieldbus
<i>P4-06</i> FOT	<p>Setting a signal output via parameter</p> <p>This parameter lets you set those signal outputs whose signal output functions have been defined by SDO_0 ... SDO_3.</p> <p>Bit 0 = 1 sets those signal outputs whose signal output function has been set to SDO_0.</p> <p>Bit 1 = 1 sets those signal outputs whose signal output function has been set to SDO_1.</p> <p>Bit 2 = 1 sets those signal outputs whose signal output function has been set to SDO_2.</p> <p>Bit 3 = 1 sets those signal outputs whose signal output function has been set to SDO_3.</p> <p>See P2-18 ... P2-21 for assigning the functions to the digital outputs.</p>	- 0 _h 0 _h FF _h Hexadecimal	u16 RW -	Modbus 50C _h P-0-3004.0.6

Forcing the Digital Signal Inputs and Signal Outputs

Forcing of signals means that the digital inputs and outputs are set manually. Forcing input and output values can have serious consequences on the operation of a machine or process.

▲ WARNING

UNINTENDED EQUIPMENT OPERATION CAUSED BY FORCING

- Only force I/O if there are no persons or obstructions in the zone of operation.
- Only force I/O if you are fully familiar with the effects of the signals.
- Only force I/O for test purposes, maintenance or other short-term tasks.
- Do not use forcing for regular, long-term or in-service operation.
- Always remove forcing when the task (testing, maintenance or other short-term operation) is completed.

Failure to follow these instructions can result in death, serious injury, or equipment damage.

Forcing the Digital Inputs

Forcing of the digital inputs is set via the parameters P3-06 and P4-07.

The parameter P3-06 lets you specify which digital signal inputs are allowed to be forced.

Parameter name	Description	Unit Minimum value Factory setting Maximum value HMI Format	Data type R/W Persistent	Parameter address via fieldbus
P3-06 SDI	Digital Inputs - Forcing Settings This parameter determines whether a digital input can be forced. Bits 0 ... 7: Digital input DI1 ... Digital input DI8 Bit settings: Value 0: Digital input cannot be forced Value 1: Digital input can be forced To start forcing, you must write P4-07. See P2-10 ... P2-17 for the assignment of signal input functions to the digital inputs.	- 0 _h 0 _h 7FF _h Hexadecimal	u16 RW -	Modbus 40C _h P-0-3003.0.6

Use parameter P4-07 to activate forcing of the digital signal inputs.

Parameter name	Description	Unit Minimum value Factory setting Maximum value HMI Format	Data type R/W Persistent	Parameter address via fieldbus
P4-07 ITST	State of Digital Inputs / Activate Forcing A read access to this parameter indicates the state of the digital inputs in the form of a bit pattern. Example: Read value 0x0011: Digital input 1 is activated By writing this parameter, you can change the state of the inputs provided that the setting for the corresponding input in P3-06 allows for forcing (value 1 for the bit corresponding to the input). Example: Write value 0x0011: Digital input 1 is activated Read value 0x0011: Digital input 1 is activated See P3-06 for permitting forcing of individual digital inputs. See P2-10 ... P2-17 for the assignment of signal input functions to the digital inputs.	- 0 _h 0 _h FF _h Hexadecimal	u16 RW -	Modbus 50E _h P-0-3008.0.15

Forcing the Digital Outputs

Forcing of the digital outputs is set via the parameters P4-27 and P4-28.

The parameter P4-27 lets you specify which digital signal outputs are allowed to be forced.

Parameter name	Description	Unit Minimum value Factory setting Maximum value HMI Format	Data type R/W Persistent	Parameter address via fieldbus
P4-27 DO_FORCE_MASK	<p>Digital Outputs - Forcing Settings</p> <p>This parameter determines whether a digital output can be forced.</p> <p>Bits 0 ... 3: Digital output DO1 ... Digital output DO4</p> <p>Bit settings: Value 0: Digital output cannot be forced Value 1: Digital output can be forced</p> <p>To start forcing, you must write P4-28.</p> <p>See P2-18 ... P2-21 for the assignment of signal output functions to the digital outputs.</p>	- 0 _h 0 _h 1F _h Hexadecimal	u16 RW -	Modbus 536 _h P-0-3004.0.27

Use parameter P4-28 to activate forcing of the digital signal outputs.

Parameter name	Description	Unit Minimum value Factory setting Maximum value HMI Format	Data type R/W Persistent	Parameter address via fieldbus
P4-28 DO_FORCE_VALUE	<p>State of Digital Outputs / Activate Forcing</p> <p>A read access to this parameter indicates the state of the digital outputs in the form of a bit pattern.</p> <p>Example: Read value 0x0011: Digital output 1 is activated</p> <p>By writing this parameter, you can change the state of the outputs provided that the setting for the corresponding output in P4-27 allows for forcing (value 1 for the bit corresponding to the output).</p> <p>Example: Write value 0x0011: Digital output 1 is activated Read value 0x0011: Digital output 1 is activated</p> <p>See P4-27 for permitting forcing of individual digital outputs.</p> <p>See P2-18 ... P2-21 for the assignment of signal output functions to the digital outputs.</p>	- 0 _h 0 _h 1F _h Hexadecimal	u16 RW -	Modbus 538 _h P-0-3004.0.28

Position Capture via Signal Input

Description

The motor position can be captured when a signal is detected at a Capture input.

Number of Capture Inputs

2 Capture inputs are available:

- Capture input: *DI7/TPROB1*
- Capture input: *DI6/TPROB2*

Selection of the Method

The motor position can be captured in 2 different ways:

- One-time position capture
One-time capture means that the position is captured at the first edge.
- Continuous motor position capture
Continuous capture means that the motor position is captured anew at every edge. The previously captured value is discarded.

The motor position can be captured when the edge at the Capture input rises or falls.

Accuracy

A jitter of 2 μ s results in an inaccuracy of the captured position of approximately 13.2 user-defined units at a velocity of 3000 RPM.

$$(3000 \text{ RPM} = (3000 * 131072) / (60 * 10^6) = 6.6 \text{ usr_p} / \mu\text{s})$$

If the factory settings for scaling are used, 13.2 user-defined units correspond to 0.036 $^{\circ}$.

The captured motor position is less accurate during the acceleration phase and the deceleration phase.

Real-time Capability

The motor position can be captured via the real-time channel. The functionalities of the real-time channel and the acyclical channel differ. The following table provides an overview:

Function	Real-time channel	Acyclical channel
Starting position capture DI7/TPROB1	Yes	Yes
Starting position capture DI6/TPROB2	Yes	Yes
Status of captured position DI7/TPROB1	Yes	Yes
Status of captured position DI6/TPROB2	Yes	Yes
One-time position capture	Yes	Yes
Continuous motor position capture	No	Yes

Setting the Edge

The following parameters let you set the edge for position capture.

- Set the desired edge with the parameters *Cap1Config* and *Cap2Config*.

Parameter name	Description	Unit Minimum value Factory setting Maximum value	Data type RW Persistent Expert	Parameter address via fieldbus
<i>Cap1Config</i>	Capture input 1 configuration 0 / Falling Edge: Position capture at falling edge 1 / Rising Edge: Position capture at rising edge 2 / Both Edges: Position capture at both edges Type: Unsigned decimal - 2 bytes Write access via Sercos: CP2, CP3, CP4 Modified settings become effective immediately.	- 0 0 2	UINT16 RW - -	IDN P-0-3010.0.2
<i>Cap2Config</i>	Capture input 2 configuration 0 / Falling Edge: Position capture at falling edge 1 / Rising Edge: Position capture at rising edge 2 / Both Edges: Position capture at both edges Type: Unsigned decimal - 2 bytes Write access via Sercos: CP2, CP3, CP4 Modified settings become effective immediately.	- 0 0 2	UINT16 RW - -	IDN P-0-3010.0.3

Starting Position Capture

The following parameters let you start position capture.

Real-time channel:

- Set the desired method with the parameter *SPDSercos3Control*.

Acyclical channel:

- Set the desired method with the parameters *Cap1Activate* and *Cap2Activate*.

Parameter name	Description	Unit Minimum value Factory setting Maximum value	Data type RW Persistent Expert	Parameter address via fieldbus
<i>SPDSercos3Control</i>	SPD Sercos control (CAP1 and CAP2) Bit 0 = 0: Cancel capture function Bit 0 = 1: Start one-time capture via input CAP1 Bit 1 = 0: Cancel capture function Bit 1 = 1: Start one-time capture via input CAP2 Bits 2 ... 15: Reserved Type: Unsigned decimal - 2 bytes Write access via Sercos: CP2, CP3, CP4 Modified settings become effective immediately.	- - - -	UINT16 RW - -	IDN P-0-3025.0.80
<i>Cap1Activate</i>	Capture input 1 start/stop 0 / Capture Stop: Cancel capture function 1 / Capture Once: Start one-time capture 2 / Capture Continuous: Start continuous capture 3 / Reserved: Reserved 4 / Reserved: Reserved In the case of one-time capture, the function is terminated when the first value is captured. In the case of continuous capture, the function continues to run. Type: Unsigned decimal - 2 bytes Write access via Sercos: CP2, CP3, CP4 Modified settings become effective immediately.	- 0 - 4	UINT16 RW - -	IDN P-0-3010.0.4
<i>Cap2Activate</i>	Capture input 2 start/stop 0 / Capture Stop: Cancel capture function 1 / Capture Once: Start one-time capture 2 / Capture Continuous: Start continuous capture 3 / Reserved: Reserved 4 / Reserved: Reserved In the case of one-time capture, the function is terminated when the first value is captured. In the case of continuous capture, the function continues to run. Type: Unsigned decimal - 2 bytes Write access via Sercos: CP2, CP3, CP4 Modified settings become effective immediately.	- 0 - 4	UINT16 RW - -	IDN P-0-3010.0.5

Status Messages

Real-time channel:

- The parameter *SPDSercos3Status* indicates the capture status.

Acyclical channel:

- The parameter *Touch Probe Status* indicates the capture status.

Parameter name	Description	Unit Minimum value Factory setting Maximum value	Data type RW Persistent Expert	Parameter address via fieldbus
<i>_SPDSercos3Status</i>	SPD Sercos status (CAP1 and CAP2) Bit 0 = 0: No position captured via input CAP1 Bit 0 = 1: Position captured via input CAP1 Bit 1 = 0: No position captured via input CAP2 Bit 1 = 1: Position captured via input CAP2 Bit 2 = 0: Positive limit switch not active Bit 2 = 1: Positive limit switch active Bit 3 = 0: Negative limit switch not active Bit 3 = 1: Negative limit switch active Bit 4 = 0: Quick Stop: Standstill not yet reached Bit 4 = 1: Quick Stop: Standstill reached Type: Unsigned decimal - 2 bytes Modified settings become effective immediately.	- - - -	UINT16 RO - -	IDN P-0-3025.0.81
<i>Touch Probe Status</i>	Status of the capture inputs Read access: Bit 0: Position captured via input CAP1 Bit 1: Position captured via input CAP2 Type: Unsigned decimal - 2 bytes	- - - -	UINT16 RO - -	IDN P-0-3010.0.1

Captured Position

The captured positions can be read via the following parameters:

Parameter name	Description	Unit Minimum value Factory setting Maximum value	Data type RW Persistent Expert	Parameter address via fieldbus
<i>_Cap1Pos</i>	Capture input 1 captured position (one-time) Captured position at the time of the "capture signal". The captured position is re-calculated after "Position Setting" or "Reference Movement". Type: Signed decimal - 4 bytes	usr_p -2147483648 0 2147483647	INT32 RO - -	IDN P-0-3010.0.6
<i>_Cap2Pos</i>	Capture input 2 captured position (one-time) Captured position at the time of the "capture signal". The captured position is re-calculated after "Position Setting" or "Reference Movement". Type: Signed decimal - 4 bytes	usr_p -2147483648 0 2147483647	INT32 RO - -	IDN P-0-3010.0.7

Operating Modes

What's in This Chapter

Setting the Operating Mode.....	236
Jog Operation	240
Cyclic Synchronous Operating Modes.....	241
Operating Mode Homing	243

Setting the Operating Mode

Setting the Operating Mode

Unsuitable settings or unsuitable data may trigger unintended movements, trigger signals, damage parts and disable monitoring functions. Some parameters and other operational data do not become active until after a restart.

▲ WARNING

UNINTENDED EQUIPMENT OPERATION

- Only start the system if there are no persons or obstructions in the zone of operation.
- Do not operate the drive system with undetermined parameter values.
- Never modify a parameter value unless you fully understand the parameter and all effects of the modification.
- Restart the drive and verify the saved operational data and/or parameter values after modification.
- Carefully run tests for all operating states and potential error situations when commissioning, upgrading or otherwise modifying the operation of the drive.
- Verify the functions after replacing the product and also after making modifications to the parameter values and/or other operational data.

Failure to follow these instructions can result in death, serious injury, or equipment damage.

The drive has the following operating modes:

- Profile Homing
- Cyclic Synchronous Position
- Cyclic Synchronous Velocity
- Cyclic Synchronous Torque

The settings for the required operating mode must be made in the SERCOS III controller software.

Indication of the Operating State via Fieldbus

Description

With the parameter S-0-0135 you can read the status information of the drive.

Parameter name	Description	Unit	Data type	Parameter address via fieldbus
		Minimum value	RW	
		Factory setting	Persistent	
		Maximum value	Expert	
S-0-0135	Drive Status This parameter contains the status word of the AT. It can be used for diagnostics purposes. Type: Hexadecimal - 2 bytes Write access via Sercos: Read only	- 0 - 65535	RO - -	IDN S-0-0135

Bits	Meaning
0 ... 2	Reserved
3	Value 0: Drive ignores the command values. Value 1: Drive follows the command values.
4	Value 0: Drive Halt is not active. Value 1: Drive Halt is active.
5	Position feedback value status. Drive homed.
6	Reserved
7	Value 0: Emergency stop is not active. Value 1: Emergency stop is active.
8 ... 10	Value 0: Primary operating mode is set. Value 1: Secondary operating mode 1 is set. Value 2: Secondary operating mode 2 is set. Value >2: Reserved.
11	Reserved
12	Value 0: No error detected with the error class 0. Value 1: Detected error with the error class 0.
13	Value 0: No error detected with the error class 1, 2, 3, or 4. Value 1: Detected error with the error class 1, 2, 3, or 4.
14 ... 15	Value 0: Drive not ready. Value 1: Drive ready for main power on. Value 2: Drive ready and main power applied. Value 3: Drive enabled.

Changing the Operating State via Fieldbus

Description

With the parameter S-0-0134 you can change the operating state of the drive and select the operating mode.

Parameter name	Description	Unit	Data type	Parameter address via fieldbus
		Minimum value	RW	
		Factory setting	Persistent	
		Maximum value	Expert	
S-0-0134	Drive Control This parameter contains the control word. Type: Hexadecimal - 2 bytes Write access via Sercos: CP2, CP3, CP4	- 0 - 65535	RW - -	IDN S-0-0134

Bits	Meaning
0 ... 7	Reserved
8 ... 10	Value 0: Primary operating mode. Value 1: Secondary operating mode 1. Value 2: Secondary operating mode 2. Value >2: Reserved.
11 ... 12	Reserved
13	Value 0: Drive halt Value 1: Drive restart (after Halt)
14	Value 0: Drive disable Value 1: Drive enable
15	Value 0: Drive OFF Value 1: Drive ON

With the parameter S-0-0099 you can reset detected errors (state transition T15).

Parameter name	Description	Unit	Data type	Parameter address via fieldbus
		Minimum value	RW	
		Factory setting	Persistent	
		Maximum value	Expert	
S-0-0099	Reset class 1 diagnostic If this procedure command is received by the drive via the service channel, the detected errors, the error bits and the shut-down mechanism are cleared. Type: Binary - 2 bytes Write access via Sercos: CP2, CP3, CP4 Class name: GDP_Basic	- 0 0 7	RW - -	IDN S-0-0099

Object units

Overview

Two objects are used to set the gear ratio and the feed constant conversion factors, each of which has two subindex.

These objects have four equivalent variables:

Item	Object		Description
Feed constant	P-0-3020.0.16	Feed Unit conversion numerator	Conversion factors of the user-defined position unit. Used to multiply the motor revolution (rotary motors) or the motor pitch (linear motors), according to the configured motor type.
	P-0-3020.0.17	Shaft revolutions Unit conversion denominator	
Gear ratio	P-0-3020.0.40	Motor revolutions Motor shaft scaling for the fieldbus gear ratio	Conversion factor of the motor shaft revolution.
	P-0-3020.0.39	Shaft revolutions Drive shaft scaling for the fieldbus gear ratio	Conversion factor of the drive shaft revolution.

It is possible to modify the subindex of both objects, but it is usually sufficient to modify only the feed constant value, as shown in the following example:

$$\text{Resolution} = (P-0-3020.0.16 / P-0-3020.0.17) \times (P-0-3020.0.40 / P-0-3020.0.39)$$

Example by unit dimensions:

Unit dimension	Examples
Position units	Assuming: <ul style="list-style-type: none"> P-0-3020.0.16 = 360000 P-0-3020.0.17 = 1 P-0-3020.0.40 = 1 P-0-3020.0.39 = 1 The actual position reading = 720000 Then: $720000 / [(360000 / 1) \times (1 / 1)] = 2 \text{ revolutions}$
Velocity units	Assuming: <ul style="list-style-type: none"> P-0-3020.0.16 = 360000 P-0-3020.0.17 = 1 P-0-3020.0.40 = 1 P-0-3020.0.39 = 1 The actual velocity reading = 720000 Then: $720000 / [(360000 / 1) \times (1 / 1)] = 2 \text{ revolutions per second}$
Acceleration units	Assuming: <ul style="list-style-type: none"> P-0-3020.0.16 = 360000 P-0-3020.0.17 = 1 P-0-3020.0.40 = 1 P-0-3020.0.39 = 1 The actual acceleration reading = 720000 Then: $720000 / [(360000 / 1) \times (1 / 1)] = 2 \text{ revolutions per second}^2$
Current units	The units are derived from object P-0-3020.0.7 (Motor Rated Current) The value of this object is user-defined, in mA. After setting a value for P-0-3020.0.7, all other current objects must receive values defined in 1/1000 (one-thousandth) of P-0-3020.0.7. For example: Assuming P-0-3020.0.7 has a value of 20000 mA, then to set a value of 15000 mA for P-0-3006.0.28 (Maximum Current), write 750 for P-0-3006.0.28. The calculation is: $(750 / 1000) \times 20000 = 15000 \text{ mA}$

Examples of Rotary Motor with Gear or Rotary to Linear Motion Translation Device

When using a gear or rotary-to-linear motion translation device, set values for the translation ratio of the gear in order to define the unit variables.

Using a ball screw that converts	Object values to set
1 motor revolution to 155 mm	P-0-3020.0.16 = 1550 P-0-3020.0.17 = 1 P-0-3020.0.40 = 1 P-0-3020.0.39 = 1

This units will be as follows:

- Position in 0.1 mm
- Velocity in 0.1 mm/sec
- Acceleration in 0.1 mm.sec²

Jog Operation

Jog Operation

Description

In the Jog operation, a movement is made from the motor position in the specified direction.

The parameter *P4-05* is used to set the velocity for the movement in the unit rpm.

The movement can be performed via the arrow keys at the HMI or via the signal input functions JOGP and JOGN.

For further information on the parameterizable signal input functions, refer to *Setting the Digital Signal Inputs*, page 225.

Jog Via HMI

If the HMI is used, the movements are performed via the arrow keys. The operating mode is terminated via the **M** key.

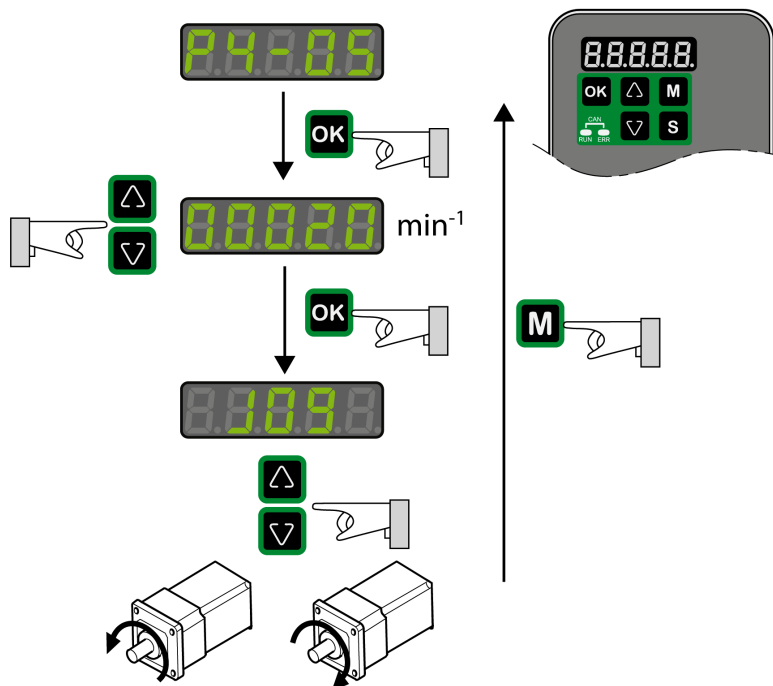

Cyclic Synchronous Operating Modes

Overview

Description

The following Cyclic Synchronous operating modes are supported:

- Cyclic Synchronous Position
- Cyclic Synchronous Velocity
- Cyclic Synchronous Torque

The motor synchronously follows the target values transmitted on a cyclic basis. The transmitted values are linearly interpolated (internally).

The possible applications for these operating mode are described in the manual of the master controller.

The operating modes are fixed set in the corresponding SERCOS parameters:

- Parameter *S-0-0032 Primary Operation Mode* for Cyclic Synchronous Position
- Parameter *S-0-0033 Secondary Operation Mode 1* for Cyclic Synchronous Velocity
- Parameter *S-0-0034 Secondary Operation Mode 2* for Cyclic Synchronous Torque

Operation Mode Cyclic Synchronous Position

The motor synchronously follows the target values transmitted on a cyclic basis. The transmitted values are linearly interpolated (internally).

The possible applications for these operating mode are described in the manual of the master controller.

Parameter name	Description	Unit	Data type	Parameter address via fieldbus
		Minimum value	RW	
		Factory setting	Persistent	
		Maximum value	Expert	
S-0-0032	<p>Primary Operation Mode</p> <p>This parameter sets the primary operating mode of the drive. The operating mode is started via bits 8, 9 and 10 in the parameter Drive Control (S-0-0134). The active operating mode is indicated by bits 8, 9 and 10 in the status word (S-0-0135).</p> <p>Type: Hexadecimal - 2 bytes</p> <p>Write access via Sercos: CP2, CP3</p>	- 3 3 3	RW - -	IDN S-0-0032

Operation Mode Cyclic Synchronous Velocity

The motor synchronously follows the target values transmitted on a cyclic basis. The transmitted values are linearly interpolated (internally).

The possible applications for these operating mode are described in the manual of the master controller.

Parameter name	Description	Unit	Data type	Parameter address via fieldbus
		Minimum value	RW	
		Factory setting	Persistent	
		Maximum value	Expert	
S-0-0033	<p>Secondary Operation Mode 1</p> <p>This parameter sets the secondary operating mode 1 of the drive. The operating mode is started via bits 8, 9 and 10 in the parameter Drive Control (S-0-0134). The active operating mode is indicated by bits 8, 9 and 10 in the status word (S-0-0135).</p> <p>Type: Hexadecimal - 2 bytes</p> <p>Write access via Sercos: CP2, CP3</p>	- 2 2 2	RW - -	IDN S-0-0033

Operation Mode Cyclic Synchronous Torque

The motor synchronously follows the target values transmitted on a cyclic basis. The transmitted values are linearly interpolated (internally).

The possible applications for these operating mode are described in the manual of the master controller.

Parameter name	Description	Unit	Data type	Parameter address via fieldbus
		Minimum value	RW	
		Factory setting	Persistent	
		Maximum value	Expert	
S-0-0034	<p>Secondary Operation Mode 2</p> <p>This parameter sets the secondary operating mode 2 of the drive. The operating mode is started via bits 8, 9 and 10 in the parameter Drive Control (S-0-0134). The active operating mode is indicated by bits 8, 9 and 10 in the status word (S-0-0135).</p> <p>Type: Hexadecimal - 2 bytes</p> <p>Write access via Sercos: CP2, CP3</p>	- 1 1 1	RW - -	IDN S-0-0034

Operating Mode Homing

Operating Mode Homing

Description

In the operating mode Homing, a reference is generated between a mechanical position and the actual position of the motor.

A reference between a mechanical position and the actual position of the motor is generated by means of a reference movement or by means of position setting.

A successful reference movement or position setting homes the motor and the zero point becomes valid.

The zero point is the point of reference for absolute movements in the operating mode Profile Position.

A movement can be made using different methods:

- Reference movement to a limit switch

In the case of a reference movement to a limit switch, a movement to the negative limit switch or the positive limit switch is performed. When the limit switch is reached, the motor is stopped and a movement is made back to the switching point of the limit switch. From the switching point of the limit switch, a movement is made to the next index pulse of the motor or to a parameterizable distance from the switching point. The position of the index pulse or the position of the parameterizable distance from the switching point is the reference point.

- Reference movement to the reference switch

In the case of a reference movement to the reference switch, a movement to the reference switch is performed. When the reference switch is reached, the motor is stopped and a movement is made back to the switching point of the reference switch. From the switching point of the reference switch, a movement is made to the next index pulse of the motor or to a parameterizable distance from the switching point. The position of the index pulse or the position of the parameterizable distance from the switching point is the reference point.

- Reference movement to the index pulse

In the case of a reference movement to the index pulse, a movement is made from the actual position to the next index pulse. The position of the index pulse is the reference point.

- Position setting

In the case of position setting, the actual position of the motor is set to a specified position value.

A reference movement must be terminated without interruption for the new zero point to be valid. If the reference movement is interrupted, it must be started again.

Procedure

- Set Position at reference point P-0-3040.0.11.
- Set *Home offset* P-0-4020.0.7.
- Set *Home method* P-0-3027.0.12, the value range is 1 to 35 and specifies the different homing methods.
- Set *Home speeds* P-0-3040.0.4 to the value for velocity to search for the limit switches (unit = 0.1 rpm).
- Set *Home speeds* P-0-3040.0.5 to the value for velocity to search for the index pulse (unit = 0.1 rpm).
- Set *Home acceleration* P-0-3020.0.21 to the value for the acceleration ramp (unit = user-defined position unit/s²).

Supported Homing Methods

Method 1: Homing on the negative limit switch and index pulse

The initial movement is in the negative direction if the negative limit switch is inactive.

The initial movement is in the positive direction if the negative limit switch is active.

The home position is at the first index pulse in the positive direction where the negative limit switch becomes inactive.

Method 2: Homing on the positive limit switch and index pulse

The initial movement is in the positive direction if the positive limit switch is inactive.

The initial movement is in the negative direction if the positive limit switch is active.

The home position is at the first index pulse in the negative direction where the positive limit switch becomes inactive.

Methods 3 and 4: Homing on the positive reference switch and index pulse

The initial movement is in the negative direction if the positive reference switch is active.

The initial movement is in the positive direction if the positive reference switch is inactive.

- Method 3: The home position is at the first index pulse in the negative direction where the reference switch becomes inactive.
- Method 4: The home position is at the first index pulse in the positive direction where the reference switch becomes active.

Methods 5 and 6: Homing on the negative reference switch and index pulse

The initial movement is in the positive direction if the negative reference switch is active.

The initial movement is in the negative direction if the negative reference switch is inactive.

- Method 5: The home position is at the first index pulse in the positive direction where the reference switch becomes inactive.
- Method 6: The home position is at the first index pulse in the negative direction where the reference switch becomes active.

Methods 7 to 10: Homing on the reference switch and index pulse (Positive)

These methods use a reference switch which is active over only a portion of the travel.

The initial movement is in the positive direction if the reference switch is inactive.

The initial movement is in the negative direction if the reference switch is active.

If the initial movement leads away from the reference switch, the drive reverses on encountering the positive limit switch.

- Method 7: The home position is at the first index pulse in the negative direction where the reference switch becomes inactive.
- Method 8: The home position is at the first index pulse in the positive direction where the reference switch becomes active.
- Method 9: The home position is at the first index pulse in the negative direction where the reference switch becomes active.
- Method 10: The home position is at the first index pulse in the positive direction where the reference switch becomes inactive.

Methods 11 to 14: Homing on the reference switch and index pulse (Negative)

These methods use a reference switch which is active over only a portion of the travel.

The initial movement is in the negative direction if the reference switch is inactive.

The initial movement is in the positive direction if the reference switch is active.

If the initial movement leads away from the reference switch, the drive reverses on encountering the negative limit switch.

- Method 11: The home position is at the first index pulse in the positive direction where the reference switch becomes inactive.
- Method 12: The home position is at the first index pulse in the negative direction where the reference switch becomes active.
- Method 13: The home position is at the first index pulse in the positive direction where the reference switch becomes active.
- Method 14: The home position is at the first index pulse in the negative direction where the reference switch becomes inactive.

Methods 15 and 16: Reserved

Method 17: Homing on the negative limit switch

The initial movement is in the negative direction if the negative limit switch is inactive.

The initial movement is in the positive direction if the negative limit switch is active.

The home position is in the positive direction where the negative limit switch becomes inactive.

Method 18: Homing on the positive limit switch

The initial movement is in the positive direction if the positive limit switch is inactive.

The initial movement is in the negative direction if the positive limit switch is active.

The home position is in the negative direction where the positive limit switch becomes inactive.

Methods 19 and 20: Homing on the positive reference switch

The initial movement is in the negative direction if the positive reference switch is active.

The initial movement is in the positive direction if the positive reference switch is inactive.

- Method 19: The home position is in the negative direction where the reference switch becomes inactive.

- Method 20: The home position is in the positive direction where the reference switch becomes active.

Methods 21 and 22: Homing on the negative reference switch

The initial movement is in the positive direction if the negative reference switch is active.

The initial movement is in the negative direction if the negative reference switch is inactive.

- Method 21: The home position is in the positive direction where the reference switch becomes inactive.
- Method 22: The home position is in the negative direction where the reference switch becomes active.

Methods 23 to 26: Homing on the reference switch (Positive)

These methods use a reference switch which is active over only a portion of the travel.

The initial movement is in the positive direction if the reference switch is inactive.

The initial movement is in the negative direction if the reference switch is active.

If the initial movement leads away from the reference switch, the drive reverses on encountering the positive limit switch.

- Method 23: The home position is in the negative direction where the reference switch becomes inactive.
- Method 24: The home position is in the positive direction where the reference switch becomes active.
- Method 25: The home position is in the negative direction where the reference switch becomes active.
- Method 26: The home position is in the positive direction where the reference switch becomes inactive.

Methods 27 to 30: Homing on the reference switch (Negative)

These methods use a reference switch which is active over only portion of the travel.

The initial movement is in the negative direction if the reference switch is inactive.

The initial movement is in the positive direction if the reference switch is active.

If the initial movement leads away from the reference switch, the drive reverses on encountering the negative limit switch.

- Method 27: The home position is in the positive direction where the reference switch becomes inactive.
- Method 28: The home position is in the negative direction where the reference switch becomes active.
- Method 29: The home position is in the positive direction where the reference switch becomes active.
- Method 30: The home position is in the negative direction where the reference switch becomes inactive.

Methods 31 and 32: Reserved

Methods 33 and 34: Homing on the index pulse

- Method 33: The home position is at the first index pulse in the negative direction.
- Method 34: The home position is at the first index pulse in the positive direction.

Methods 35: Homing on the current position

The current position is considered as the home position.

Starting the Operating Mode

The parameter S-0-0148 is used to start the operating mode Homing.

Terminating the Operating Mode

The operating mode is terminated when the motor is at a standstill and one of the following conditions is met:

- Homing successful
- Stop caused by "Halt" or "Quick Stop"
- Stop caused by a detected error

Diagnostics and Troubleshooting

What's in This Part

Diagnostics and Troubleshooting.....	249
--------------------------------------	-----

Diagnostics and Troubleshooting

What's in This Chapter

SERCOS III Status 249
 Diagnostics Via the Integrated HMI 250
 Diagnostics Via the Signal Outputs 251
 Diagnostics Via the Commissioning Software 251
 Status Information on Detected Errors 251
 Connection for Fieldbus Mode 253
 Alert Codes and Error Codes 253

SERCOS III Status

Overview

The SERCOS III status information is available:

- On the product front panel with 2 dedicated LEDs
- By reading the SERCOS III diagnostic parameters

SERCOS III Status LEDs

Two network diagnostic LEDs are located on the front panel of the drive.

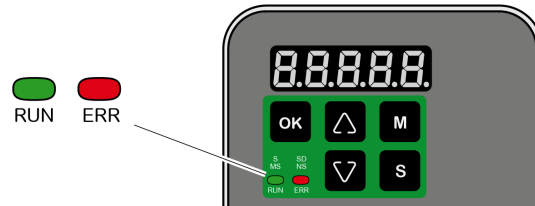

RUN: Network RUN Status





This S LED indicates the SERCOS III state:

Colors & Status	Priority	Description
	0	No SERCOS III communication
	0	Communication phase 0 active
	0	Communication phase 1 active
	0	Communication phase 2 active
	0	Communication phase 3 active
	0	Communication phase 4 active
	1	Device is in hot-plug phase 0
	1	Device is in hot-plug phase 1
	1	Device is in hot-plug phase 2
	1	Device is in hot-plug phase 2
	2	Real-time state is "loopback"
	3	Application error
	4	MST transmission error ≥S-0-1003/2
	5	communication error

Colors & Status	Priority	Description
	6	Identification ("IdentifyDevice")
	7	Application is not running

ERR: Network Error Status

This SD LED indicates the sub-device status:

Color	Priority	Description
	0	Sub-device is not active
	0	Sub-device is in state "parametrization level (PL)"
	0	Sub-device is in state "operating level (OL)"
	1	Sub-device is in state "application error (C1D)"

Diagnostics Via the Integrated HMI

Modbus Activity

The left most decimal point in the integrated HMI indicates Modbus activity by flashing.

Error Memory

Parameters *P4-00* to *P4-04* allow you to read the error memory.

The error memory also contains a history of the last 5 detected errors.

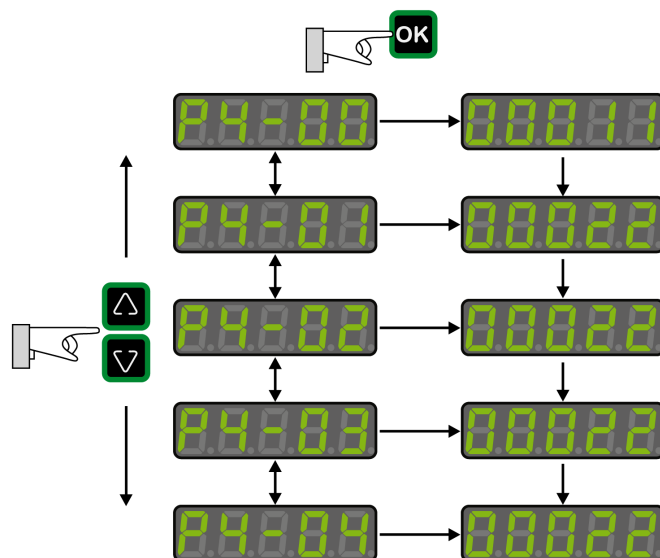

Parameter	Description
P4-00	Error number of the most recently detected error
...	...
P4-04	Error number of the oldest detected error

The parameter *P0-47* allows you to read the last detected alert.

Diagnostics Via the Signal Outputs

The signal outputs allow you to indicate, among other things, operating states and detected errors. The following list is an excerpt of the parameterizable signal output functions. For additional signal output functions, refer to *Setting the Digital Signal Outputs*, page 226.

Setting A for P2-18 ... P2-21	Short name	Name of the output function	Description
1	SRDY	Servo Ready	The signal output function SRDY indicates that no errors are presently detected, i.e. the drive is not in the operating state Fault.
2	SON	Servo On	The signal output function SON indicates that the drive is in the operating state Operation Enabled.
7	ERROR	Error Detected	The signal output function ERROR indicates that an error has been detected and that the drive has switched to the operating state Fault. For further information, refer to <i>Diagnostics and Troubleshooting</i> , page 249.
11	WARN	Advisory or Alert Signal activated	The signal output function indicates that one of the following conditions has been detected: Hardware limit switch triggered, undervoltage, Nodeguard alert, Operational Stop (OPST).

Diagnostics Via the Commissioning Software

See the information provided with the commissioning software for details on how to display the device state via the commissioning software LXM28 DTM Library.

Status Information on Detected Errors

Description

Status information on detected errors are provided via the parameter *S-0-0135*, bits 12 and 13. The status information shows the error class of a detected error.

The parameter *S-0-0390* allows you to read the error code of the detected error.

Parameter name	Description	Unit	Data type	Parameter address via fieldbus
<i>S-0-0390</i>	Diagnostic number The operation data of this parameter contains detailed information on the diagnostics event with the highest priority which is currently active in the drive. Type: Hexadecimal - 4 bytes Write access via Sercos: Read only Class name: GDP_Basic	- 0 0 4294967295	RO - - Expert	IDN S-0-0390

Bits	Meaning
0 ... 15	Value 0: No error detected. Value >0: Error code of the detected error.
16 ... 19	Value 14: Detected Alert-level error. Value 15: Detected Alarm-level error.
20 ... 23	Reserved
24 ... 29	Value 1: SERCOS III FSP IO
30 ... 31	Value 1: Fully manufacture specific.

The parameters *S-0-0011* and *S-0-0012* also provide information on detected errors.

Parameter name	Description	Unit	Data type	Parameter address via fieldbus
		Minimum value	RW	
		Factory setting	Persistent	
		Maximum value	Expert	
<i>S-0-0011</i>	Class 1 diagnostic (C1D) This parameter provides information on detected errors. A class 1 diagnostics error leads to a Quick Stop (with transition to operating state Fault). Type: Hexadecimal - 2 bytes Write access via Sercos: Read only	- 0 0 65535	RO - -	IDN S-0-0011
<i>S-0-0012</i>	Class 2 diagnostic (C2D) This parameter provides information on alerts. Type: Hexadecimal - 2 bytes Write access via Sercos: Read only	- 0 0 65535	RO - -	IDN S-0-0012

C1D and C2D supported Objects

Supported detected errors

Error code	Error number (hex)
AqB Communication interruption	5603
AL575	5600
AL576	3201
AL009	8000
AL539	5600
AL003	3201
AL002	3200
AL001	2300
AL026	8000
AL3E1	8000
5V out of range	8000
AL514	4300
AL016	4100
AL528	4100
AL529	4100

Error code	Error number (hex)
AL508	3300
AL006	3300

Supported alarms

Error code	Error number (hex)
Wn709	B124
Wn702	3201
Wn743	8000
Wn704	4301
Wn703	4101
Wn701	8000
Wn023	8000

Connection for Fieldbus Mode

Description

If the product cannot be addressed via the fieldbus, check the following connections:

- Power connections to the device.
- Network cable and network wiring.
- Network connection to the device.

Alert Codes and Error Codes

Meaning of an Alert

An alert indicates a potential issue that was detected by a monitoring function. An alert does not trigger a transition of the operating state.

Number	Description	Cause	Remedy
AL014	Negative hardware limit switch triggered	-	-
AL015	Positive hardware limit switch triggered	-	-
AL283	Positive software limit switch triggered	-	-
AL285	Negative software limit switch triggered	-	-
Wn023	Alert threshold reached: Motor overload (foldback)	The foldback current of the motor has dropped below the alert threshold specified via the parameter P1-28.	Verify correct settings of the parameter P1-28 for the foldback current of the motor.
Wn700	Safety function Safe Torque Off (STO) triggered while the power stage was disabled	The safety function STO has been triggered or the signal for the safety function STO is not properly connected. If this condition is detected while the power stage is enabled, the drive detects an error. If this condition is detected while the power stage is disabled, the drive detects an alert.	Check whether the safety function STO was triggered intentionally. If not, verify correct connection of the signal of the safety function STO.

Number	Description	Cause	Remedy
Wn701	Alert threshold reached: Drive overload (foldback)	The foldback current of the drive has dropped below the alert threshold specified via the parameter P1-24.	Verify correct settings of the parameter P1-24 for the foldback current of the drive.
Wn702	The DC bus voltage has dropped below the alert threshold.	Power supply loss, poor power supply.	Verify correct mains supply. Verify that the undervoltage limit is set correctly via the parameter P4-24.
Wn703	Alert threshold reached: Power stage overtemperature	Ambient temperature is too high, fan is inoperative, dust.	Verify correct operation of the fan. Improve the heat dissipation in the control cabinet. Remove pollution and verify that dust cannot get into the control cabinet or into the drive.
Wn704	Alert threshold reached: Motor overtemperature	The motor temperature is excessively high.	Verify correct settings of the parameters for temperature monitoring. Verify proper ventilation and heat dissipation of the motor. Clean off pollutants such as dust. Verify that the motor is evenly mounted to the flange plate. Increase the size of the flange plate to which the motor is mounted to improve heat dissipation. Verify that the motor is properly sized for the application.
Wn707	Alert threshold reached: Drive overtemperature (controller)	Ambient temperature is too high, fan is inoperative, dust.	Verify correct operation of the fan. Improve the heat dissipation in the control cabinet. Remove pollution and verify that dust cannot get into the control cabinet or into the drive.
Wn713	Positive hardware limit switch and negative hardware limit triggered	-	-
Wn716	Positive software limit switch and negative software limit triggered	-	-
Wn728	Alert: Missing mains supply, undervoltage mains supply	At least one mains phase is missing. Mains voltage is out of range. Mains frequency is out of range.	Verify correct connection of mains supply. Verify that the values of the mains power supply network comply with the technical data.
Wn729	Modbus: Node Guarding error detected	Incorrect Modbus connection, incorrect data from Modbus master.	Verify correct Modbus connection. Verify correct operation of Modbus master.
Wn730	Alert threshold reached: Braking resistor overload	The permissible braking resistor power has been exceeded.	Verify correct rating of the braking resistor used. Verify your application.
Wn731	Encoder error detected	Refer to parameter P8-49 for details.	-
Wn732	Alert threshold reached: Processing time too long	-	-
Wn734	Alert threshold reached: Drive overtemperature (IPM)	Ambient temperature is too high, fan is inoperative, dust.	Verify correct operation of the fan. Improve the heat dissipation in the control cabinet. Remove pollution and verify that dust cannot get into the control cabinet or into the drive.
Wn737	Parameters have been reset to the factory settings, but are not yet saved to the non-volatile memory.	-	Use parameter P2-08 = 11 to save parameters reset to the factory settings to the non-volatile memory and restart the drive.
Wn739	Temperature value for monitoring function not available	-	-
Wn742	Motor type has changed	The type of motor connected is different from the previously connected type of motor.	Reset the drive to the factory settings.
Wn743	Fan circuit alert	The fan circuit is either overloaded or disconnected.	Check for fan short circuit or disconnection.
Wn744	Excessive electronic noise	-	Check proper grounding and shielding. Use line filter.
Wn745	Configured feedback type and actual connected encoder mismatch	The connected encoder does not correspond to configured feedback type.	Check that configured feedback type and connected encoder match.
Wn746	Encoder overtemperature	-	-
Wn747	Encoder internal flash memory error detected	-	-

Number	Description	Cause	Remedy
Wn748	Encoderfeedback error detected	The device has detected unusually high shaft displacement. The device can still operate correctly; but position error might be higher than usual.	-
Wn749	The multi-turn battery voltage is within the following range: $3\text{ V} < \text{VBAT} < 3.15\text{ V}$. Battery voltage has started to drop; but the multi-turn information is still reliable.	-	Replace encoder battery.
Wn750	The multi-turn counter exceeded the range of 16 bit signed value. Multi-turn counter < -32768 Or multi-turn counter > 32767	-	Execute multi-turn Config/Reset (Set Reference Point) by command P8-44=3/2. For some applications which will rotate motor in one direction, the alert Wn750 for checking turns number within -32768 ... 32767 can be turned off by parameter P5-80=1.
Wn751	The last save operation was interrupted.	The last save operation was interrupted by power cycle. The former set of parameters are active.	Set the new parameter configuration and perform save command.
Wn752	Stop filter command cannot be set	SensAR Encoder Filter Mode is not supported on the connected Motor.	Set P8-71 to 0 ignore the alert. OR: Upgrade Motor Hardware version.
Wn753	Reference position reset	AL576 or homing procedure error or the multi-turn roll over will cause this alert.	Execute multi-turn Config/Reset (Set Reference Point) by command P8-44=2 Or Execute a homing procedure. Or set P5-80 to 1.

Meaning of an Error

An error is a discrepancy between a computed, measured, or signaled value or condition and the specified or theoretically correct value or condition detected by a monitoring function. An error triggers a transition of the operating state.

Number	Short description	Cause	Remedy
AL001	Power stage overcurrent	An overcurrent has been detected at the power stage which may be caused by a short circuit or by incorrect settings of the current loop parameters. This condition may occur up to three times in succession. After the third time, a time delay of one minute must pass before the power stage can be enabled again.	Verify correct connection of the motor. Verify correct settings of the parameters for the current loop.
AL002	DC bus overvoltage	The DC bus voltage exceeded the maximum value.	Verify your application. Reduce the external load, the motor velocity, or the deceleration. Use an appropriately rated braking resistor, if necessary.
AL003	DC bus undervoltage	Power supply loss, poor power supply.	Verify correct mains supply. Verify that the undervoltage limitation is set correctly via the parameter P4-24.
AL005	Braking resistor overload	The braking resistor has been on for such a long period of time that its overload capability has been exceeded.	Verify your application. Reduce the external load, the motor velocity, or the deceleration. Use a braking resistor with a greater rating, if necessary.
AL006	Motor overload (foldback)	The foldback current of the motor has dropped below the value specified via the parameter P1-27.	Verify correct settings for the parameter P1-27.
AL007	Actual motor velocity too high.	The actual motor velocity exceeded the velocity limitation by more than 20% (P1-55).	Verify that the velocity limitation set via the parameter P1-55 matches the requirements of the application. Verify that the values for the tuning parameters are suitable.

Number	Short description	Cause	Remedy
AL008	Frequency of reference value signal is too high	The frequency of the pulse signal (A/B, Pulse/Direction, CW/CCW) exceeds the specified range. Received pulses may be lost.	Adapt the output pulse frequency of the external source to fit the input specification of the drive. Adapt the gear ratios to the application requirements (parameters P1-44, P1-45).
AL009	Position deviation too high (following error)	The position deviation has exceeded the maximum permissible position deviation specified via the parameter P2-35 and the drive has detected a following error.	Verify your application. Reduce the external load. Increase the permissible position deviation via the parameter P2-35. Reduce the motor velocity via the parameters P1-09 ... P1-11. Increase the torque limitation via the parameters P1-12 ... P1-14.
AL013	The input to which the signal input function OPST is assigned has been activated.	-	Identify the cause which has triggered the signal input function OPST. Remove the cause. If your application does not require the signal input function OPST, disable this signal input function.
AL016	Power stage overtemperature	Ambient temperature is too high, fan is inoperative, dust.	Verify correct operation of the fan. Improve the heat dissipation in the control cabinet. Remove pollution and verify that dust cannot get into the control cabinet or into the drive.
AL017	Error detected in non-volatile memory	The drive was reset to the factory settings via parameter P2-08.	Use parameter P2-08 = 11 to save parameters reset to the factory settings to the non-volatile memory and restart the drive. Contact technical support.
AL018	Encoder simulation frequency exceeded 4 MHz	The computed equivalent encoder output frequency exceeds the maximum limit of 4 MHz for this signal.	Reduce the resolution of the encoder simulation via the parameter P1-46 or reduce the maximum velocity.
AL020	Modbus: Node Guarding error detected	Incorrect Modbus connection, incorrect data from Modbus master.	Verify correct Modbus connection. Verify correct operation of Modbus master.
AL022	Missing mains supply, undervoltage mains supply	At least one mains phase is missing. Mains voltage is out of range. Mains frequency is out of range.	Verify correct connection of mains supply. Verify that the values of the mains power supply network comply with the technical data.
AL025	Not possible to read data of electronic motor nameplate	Incorrect or missing motor data. Motor without electronic motor nameplate has been connected.	Verify that the drive and the connected motor are a permissible product combination. Verify correct connection of the encoder. Contact Technical Support or replace the motor.
AL026	Error detected in communication with motor encoder	Communication with the encoder was not initialized correctly.	Verify correct connection of the encoder. Contact Technical Support or replace the motor.
AL030	Motor torque too high for an excessive period of time	The motor torque has exceeded the value specified via the parameter P1-57 for a period of time exceeding the value specified via the parameter P1-58.	Verify your application. Verify that no movements are made up to a mechanical stop (for example, use limit switches). Verify that the values for the parameters P1-57 and P1-58 are suitable.
AL3E1	Drive is not synchronous with master cycle	Operating mode has been activated but drive is not synchronized to external synchronization signal.	Verify correct communication connection.
AL401	Fieldbus: Communication error detected	While the power stage was enabled, a command was received requesting a different communication state.	Verify that the master does not try to change the communication state while the power stage of the drive is enabled.
AL501	Safety function Safe Torque Off (STO) triggered	The safety function STO has been triggered or the signal for the safety function STO is not properly connected. If this condition is detected while the power stage is enabled, the drive detects an error. If this condition is detected while the power stage is disabled, the drive detects an alert.	Check whether the safety function STO was triggered intentionally. If not, verify correct connection of the signal of the safety function STO.
AL502	System error detected (FPGA)	-	Contact technical support.
AL503	System error detected (non-volatile memory)	-	Contact technical support.

Number	Short description	Cause	Remedy
AL504	System error detected (non-volatile memory)	-	Contact technical support.
AL505	DC bus voltage measurement	An error was detected in the circuit that measures the DC bus voltage.	Perform a Fault Reset. Restart the drive. If the error persists, contact Technical Support.
AL507	System error detected (NV access)	-	Contact technical support.
AL508	Drive overload (foldback)	The foldback current of the drive has dropped below the value specified via the parameter P1-23.	Verify correct settings for the parameter P1-23.
AL514	Motor overtemperature	The motor temperature is excessively high.	Verify correct settings of the parameters P1-62 and P1-63 for temperature monitoring. Verify proper ventilation and heat dissipation of the motor. Clean off pollutants such as dust. Verify that the motor is evenly mounted to the flange plate. Increase the size of the flange plate to which the motor is mounted to improve heat dissipation. Verify that the motor is properly sized for the application.
AL517	Encoder overvoltage or overcurrent	The current supplied by the drive for the 5 V encoder supply has exceeded the limit. This condition may occur up to three times in succession. After the third time, a time delay of one second must pass before the power stage can be enabled again.	Verify correct connection of the encoder (short circuits). Verify the current consumption of the encoder.
AL520	Target position rejected	A target position was rejected because it would have caused the motor to exceed the maximum velocity.	Verify that target positions do not lead to excessive motor velocities.
AL523	System error detected (self-test)	The self-test has detected an error.	Contact technical support.
AL525	Reserved	-	-
AL526	Reserved	-	-
AL527	System error detected (Watchdog)	The Watchdog function has detected a system error.	Restart the drive. If the error persists, contact Technical Support.
AL528	Drive overtemperature (IPM)	Ambient temperature is too high, fan is inoperative, dust.	Verify correct operation of the fan. Improve the heat dissipation in the control cabinet. Remove pollution and verify that dust cannot get into the control cabinet or into the drive.
AL529	Drive overtemperature (controller)	Ambient temperature is too high, fan is inoperative, dust.	Verify correct operation of the fan. Improve the heat dissipation in the control cabinet. Remove pollution and verify that dust cannot get into the control cabinet or into the drive.
AL532	Calculated offsets for current sensors out of range	The calculated offsets for the current sensors are out of range.	Perform a Fault Reset. Restart the drive. If the error persists, contact Technical Support.
AL533	Reserved	-	-
AL534	Pulse signal missing	One of the pulse signals is not connected.	Verify correct connection of the pulse inputs.
AL535	System error detected (FPGA does not match firmware)	The firmware version is not suitable for the drive.	Update the firmware of the drive. Contact technical support.
AL539	Motor phase missing	One of the motor phases is not connected.	Verify correct connection of the motor phases. Contact technical support.
AL547	Motor blocked	The motor was blocked mechanically, for example, by a mechanical stop or by the load.	Remove condition causing the mechanical blocking. Verify your application.
AL555	Velocity deviation too high	The deviation between actual velocity and reference velocity has exceeded the maximum velocity deviation specified via the parameter P2-34.	Verify your application. Verify that the values for the tuning parameters are suitable. Increase the value for the maximum velocity deviation in the parameter P2-34.
AL557	No target values received via the fieldbus	No target values have been received via the fieldbus three times in succession.	Perform a Fault Reset. Verify that target values are transmitted via the fieldbus.

Number	Short description	Cause	Remedy
AL558	System error detected	-	Contact technical support.
AL560	Power stage supply off	-	Power on the power stage supply.
AL561	Temperature sensor inoperative	-	Restart the drive. If the error persists, contact Technical Support.
AL563	Commutation error detected	Motor phases have been interchanged.	Verify correct connection of the motor phases.
AL567	System error detected (encoder)	Refer to parameter P8-48 for details.	Contact technical support.
AL568	Braking resistor overload	The permissible braking resistor power has been exceeded.	Verify correct rating of the braking resistor used. Verify your application.
AL569	Configuration not correctly transferred via Modbus	-	Verify correct connection. Verify that configuration file and drive are compatible.
AL570	Overcurrent detected at one of the digital outputs	-	Verify correct wiring of the digital outputs. Verify that there are no short circuits.
AL571	Reference position operation rejected	If you directly perform Homing, or P8-44 = 2, after modifying P1-01 C (byte 2) without power-cycling the drive, then error AL571 is reported.	Power-cycle the drive and then perform Homing or set P8-44 to 2.
AL572	Position deviation too high (following error)	The position deviation has exceeded the maximum permissible position deviation specified via the parameter P2-35 and the drive has detected a following error.	Verify your application. Reduce the external load. Increase the permissible position deviation via the parameter P2-35. Reduce the motor velocity via the parameters P1-09 ... P1-11. Increase the torque limitation via the parameters P1-12 ... P1-14.
AL573	The returned position values are no longer considered valid	Usually caused by inoperable encoder hardware or incorrect encoder assembly, for example: damaged hall sensors, damaged encoder rotor, displacement between motor shaft and encoder is too great, or corrupted encoder FLASH memory - corrupts calibration tables.	Replace new motor.
AL574	The encoder temperature is too high	Caused when temperature on encoder is too high relative to what was configured.	Reduce temperature applied on encoder or replace new motor.
AL575	The encoder supply voltage has dropped under operational value	The device supply voltage has dropped under operational value.	Make sure power supplied to encoder is according to specifications. or replace new driver
AL576	The multi-turn encoder battery voltage has dropped under 3 Vdc	The multi-turn encoder battery voltage has dropped under 3 Vdc. Battery box cable disconnect from motor encoder side.	Check battery box cable Check battery voltage Replace encoder battery Clear AL576 by command P8-44=1
AL577	The multi-turn encoder requires an explicit configuration command	–	Execute MT Config/Reset (Set Reference Point) by command P8-44=3/2.
AL578	Internal position synchronization error detected between the multi-turn and the single-turn modules	Possible reasons: incorrect multi-turn calibration, corrupted multi-turn calibration data on FLASH, internal multi-turn chip error, or incorrect multi-turn chip magnetic screw.	Replace new motor.
AL579	Generic error code of the multi-turn module is detected	Encoder is damaged or that a magnetic screw is missing or multi-turn calibration is either missing or corrupt or battery disconnect form encoder for a long time or the FW version of encoder is below 13020023.	Reconnect battery to encoder and Execute MT Config/Reset (Set Reference Point) by command P8-44=3/2. Then power cycle the drive. If this error happens again, contact your local Schneider Electric service representative.
AL580	The encoder firmware cannot operate on the provided hardware	–	–
AL581	The drive firmware cannot operate with the provided encoder version	–	–
AL582	The drive firmware cannot operate on the provided hardware	–	–
AL588	RT Overload error	Real time execution time is more than 31.25us	Too much load on the real time loop such as: too many PDO (RX/TX) are mapped/

Number	Short description	Cause	Remedy
		Mapping large amount of PDO	sync-position/record/touch probe are tasks with large impact to the CPU.
AL595	Impermissible combination of drive and motor	-	Use an approved drive/motor combination.
AL596	Unstable current loop	Excessive overshoot in current loop.	Verify correct settings of the parameters for the current loop.
AL598	Invalid Quick Stop active state	A Quick Stop has been triggered via the fieldbus or by releasing access right. The Quick Stop option code (P3-31) has been set to -1 or -2 which causes the drive to transition to the operating state 9 Fault instead of the operating state 7 Quick Stop Active.	Verify correct setting of the parameter P3-31.
AL599	DSP Response Timeout error	SDO or AT message response took too long.	Reduce the number of AT configuration in User Cyclic data.
AL5A0	Drive Locked	Hardware issue causing problems accessing nonvolatile memory.	Return drive to factory check HW.
AL5A1	Drive is not configured	—	Implement factory restore.

New Motor Fold Back Characteristics and Parameter Setting

	P2-72: value BCH2 LB - LD	P2-72: value BCH2 LF - HF - LH	P2-72: value BCH2 MM - MR
P2-73: value 1 (default)	MFOLDT=450	MFOLDT=2450	MFOLDT=3400
P2-73: value 2	MFOLDT=750	MFOLDT=7700	MFOLDT=4500
P2-73: value 3	MFOLDT=980	MFOLDT=7700	MFOLDT=5640
P2-73: value 4	MFOLDT=1670	MFOLDT=27340	MFOLDT=6840

Current [%]	BCH2 LB - LD BQ 04 - 06	MFOLDT=1670 Deviation		MFOLDT=980 Deviation		MFOLDT=750 Deviation		MFOLDT=450 Deviation	
		Overload time [s]	from MPC [%]	Overload time [s]	from MPC [%]	Overload time [s]	from MPC [%]	Overload time [s]	from MPC [%]
120	21	21	0.00	14.8	-29.52	12.7	-39.52	10	-52.38
140	6.9	9.6	39.13	6.9	0.00	6	-13.04	4.8	-30.43
160	4	5.8	45.00	4.2	5.00	3.7	-7.50	3	-25.00
180	2.6	4	53.85	2.9	11.54	2.6	0.00	2.1	-19.23
200	1.8	2.8	55.56	2.1	16.67	1.95	8.33	1.65	-8.33
220	1.3	2.16	1.54	1.65	26.92	1.5	15.38	1.3	0.00
240	1	1.57	57.00	1.27	27.00	1.17	17.00	1.05	5.00
260	0.8	1.16	45.00	0.99	23.75	0.93	16.25	0.86	7.50
280	0.7	0.85	21.43	0.77	10.00	0.75	7.14	0.71	1.43
300	0.6	0.6	0.00	0.6	0.00	0.6	0.00	0.6	0.00

Current [%]	BCH2 LF - HF - LH BQ 08 - 10	MFOLDT=27340 Deviation		MFOLDT=19500 Deviation		MFOLDT=7700 Deviation		MFOLDT=2450 Deviation	
		Overload time [s]	from MPC [%]	Overload time [s]	from MPC [%]	Overload time [s]	from MPC [%]	Overload time [s]	from MPC [%]
120	270	270	0.00	199.5	-26.11	93.3	-65.44	46	-82.96
140	90	121.3	34.78	90	0.00	42.8	-52.44	21.8	-75.78
160	36	71.7	99.17	53.5	48.61	25.9	-28.06	13.7	-61.94
180	17.5	47	168.57	35.2	101.14	17.5	0.00	9.6	-45.14

200	8.4	32.1	282.14	24.3	189.29	12.5	48.81	7.2	-14.29
220	5.6	22.2	296.43	17	203.57	9.1	62.50	5.6	0.00
240	4.2	15.1	259.52	11.7	178.57	6.7	59.52	4.4	4.76
260	3.3	9.8	196.97	7.8	136.36	4.9	48.48	3.6	9.09
280	2.5	5.7	128.00	4.8	92.00	3.5	40.00	2.9	16.00
300	2.4	2.4	0.00	2.4	0.00	2.4	0.00	2.4	0.00

Current [%]	BCH2 MM - MR	MFOLDT=6840 Deviation		MFOLDT=5640 Deviation		MFOLDT=4500 Deviation		MFOLDT=3400 Deviation	
	BQ 13 - 18	Overload time [s]	from MPC [%]	Overload time [s]	from MPC [%]	Overload time [s]	from MPC [%]	Overload time [s]	from MPC [%]
120	82.5	82.5	0.00	71.7	-13.09	61.5	-25.45	51.6	-37.45
140	33	37.8	14.55	33	0.00	28.5	-13.64	24.1	-26.97
160	18.6	22.9	23.12	20.1	8.06	17.5	-5.91	14.9	-19.89
180	12	15.5	29.17	13.7	14.17	12	0.00	10.3	-14.17
200	8.1	11	35.80	9.8	20.99	8.7	7.41	7.6	-6.17
220	5.7	8	40.35	7.2	26.32	6.5	14.04	5.7	0.00
240	4.2	5.9	40.48	5.4	28.57	4.9	16.67	4.4	4.76
260	3.3	4.3	30.30	4	21.21	3.7	12.12	3.4	3.03
280	2.7	3	11.11	2.9	7.41	2.8	3.70	2.7	0.00
300	2.1	2.1	0.00	2.1	0.00	2.1	0.00	2.1	0.00

Service, Maintenance and Disposal

What's in This Part

Service, Maintenance, and Disposal	262
--	-----

Service, Maintenance, and Disposal

What's in This Chapter

General	262
Service Address	263
Maintenance of the Drive	263
Replacement of Drive	264
Maintenance of the Motor.....	264
Lexium 26/28 Multi-Turn Encoder	266
Changing the Motor	276
Shipping, Storage, Disposal	276

General

There are no user-serviceable parts within the product. If you perceive difficulties with the operation of the product, contact your local Schneider Electric service representative.

The use and application of the information contained herein require expertise in the design and programming of automated control systems.

Only you, the user, machine builder or integrator, can be aware of all the conditions and factors present during installation and setup, operation, repair and maintenance of the machine or process.

You must also consider any applicable standards and/or regulations with respect to grounding of all equipment. Verify compliance with any safety information, different electrical requirements, and normative standards that apply to your machine or process in the use of this equipment.

Many components of the equipment, including the printed circuit board, operate with mains voltage, or present transformed high currents, and/or high voltages.

The motor itself generates voltage when the motor shaft is rotated.

DANGER

ELECTRIC SHOCK, EXPLOSION OR ARC FLASH

- Disconnect all power from all equipment including connected devices prior to removing any covers or doors, or installing or removing any accessories, hardware, cables, or wires.
- Place a "Do Not Turn On" or equivalent hazard label on all power switches and lock them in the non-energized position.
- Wait 15 minutes to allow the DC bus capacitors to properly discharge.
- Measure the DC bus voltage between the DC bus terminals (PA/+ and PC/-) to verify that DC bus capacitors are properly discharged (voltage less than 42.4 Vdc).
- Do not assume that the DC bus discharged properly when the DC bus LED is off.
- Block the motor shaft to prevent rotation prior to performing any type of work on the drive system.
- Do not create a short-circuit across the DC bus terminals or the DC bus capacitors.
- Replace and secure all covers, accessories, hardware, cables, and wires and confirm that a proper ground connection exists before applying power to the unit.
- Use only the specified voltage when operating this equipment and any associated products.

Failure to follow these instructions will result in death or serious injury.

Service Address

Overview

If you cannot resolve an error yourself, contact your sales office.

Have the following data available:

- Nameplate (type, identification number, serial number, DOM, ...)
- Type of error (with LED flash code or error code)
- Previous and concomitant circumstances
- Your own assumptions concerning the cause of the error

Also include this information if you return the product for inspection or repair.

If you have any questions, contact your sales office. Your sales office staff will provide you the name of a customer service office in your area.

www.se.com

Maintenance of the Drive

Overview

Prior to any type of work on the drive system, consult the chapters on Installation and Commissioning for information to be observed.

Repairs cannot be made with the device installed.

Include the following points in the maintenance plan of your machine.

Connections and Fastening

- Check all connection cables and connectors regularly for damage. Replace damaged cables immediately.
- Tighten all mechanical and electrical threaded connections to the specified torque.

Cleaning

Clean dust and dirt off the product at regular intervals. Insufficient heat dissipation to the ambient air may excessively increase the temperature.

Lifetime of the Safety Function STO

The STO safety function is designed for a lifetime of 20 years. After this period, the data of the safety function are no longer valid. The expiry date is determined by adding 20 years to the DOM shown on the nameplate of the product.

- This date must be included in the maintenance plan of the system.
- Do not use the safety function after this date.

Example:

The DOM on the nameplate of the product is shown in the format DD.MM.YY, for example 31.12.08. (31 December 2008). This means: Do not use the safety function after December 31, 2028.

Replacement of Drive

Overview

Unsuitable settings or unsuitable data may trigger unintended movements, trigger signals, damage parts and disable monitoring functions. Some parameters and other operational data do not become active until after a restart.

▲ WARNING

UNINTENDED EQUIPMENT OPERATION

- Only start the system if there are no persons or obstructions in the zone of operation.
- Do not operate the drive system with undetermined parameter values.
- Never modify a parameter value unless you fully understand the parameter and all effects of the modification.
- Restart the drive and verify the saved operational data and/or parameter values after modification.
- Carefully run tests for all operating states and potential error situations when commissioning, upgrading or otherwise modifying the operation of the drive.
- Verify the functions after replacing the product and also after making modifications to the parameter values and/or other operational data.

Failure to follow these instructions can result in death, serious injury, or equipment damage.

Replacement of Drive Procedure

Prepare a list with the parameters required for the functions used.

Observe the following procedure when replacing devices:

Step	Action
1	Save all parameter settings. Save the data to your PC using the commissioning software, refer to chapter Commissioning Software, page 143.
2	Power off all supply voltages. Verify that no voltages are present.
3	Label all connections and remove all connection cables (unlock connector locks).
4	Uninstall the product.
5	Note the identification number and the serial number shown on the product nameplate for later identification.
6	Install the new product as per chapter Installation, page 95.
7	If the product to be installed has previously been used in a different system or application, you must restore the factory settings before commissioning the product.
8	Commission the product as per chapter Commissioning, page 134.

Maintenance of the Motor

Overview

Prior to any type of work on the drive system, consult the chapters on Installation and Commissioning for information to be observed.

Repairs cannot be made with the device installed.

Include the following points in the maintenance plan of your machine.

Connections and Fastening

- Inspect all connection cables and connectors regularly for damage. Replace damaged cables immediately.
- Verify that all output elements are firmly seated.
- Tighten all mechanical and electrical threaded connections to the specified torque.

Lubricating the Shaft Sealing Ring

In the case of motors with shaft sealing ring, lubricant must be applied to the space between the sealing lip of the shaft sealing ring and the shaft with a suitable non-metallic tool. If the shaft sealing rings are allowed to run dry, the service life of the shaft sealing rings will be significantly reduced.

Cleaning

If the permissible ambient conditions are not respected, external substances from the environment may penetrate the product and cause unintended movement or equipment damage.

▲ WARNING

UNINTENDED MOVEMENT

- Verify that the ambient conditions are respected.
- Do not allow seals to run dry.
- Keep liquids from getting to the shaft bushing (for example, in mounting position IM V3).
- Do not expose the shaft sealing rings and cable entries of the motor to the direct spray of a pressure washer.

Failure to follow these instructions can result in death, serious injury, or equipment damage.

Clean dust and dirt off the product at regular intervals. Insufficient heat dissipation to the ambient air may excessively increase the temperature.

Motors are not suitable for cleaning with a pressure washer. The high pressure may force water into the motor.

When using solvents or cleaning agents, verify that the cables, cable entry seals, O-rings, and motor paint are not damaged.

Replacing the Rolling Bearing

When the rolling bearing is replaced, the motor is partially demagnetized and loses power.

NOTICE

INOPERABLE EQUIPMENT

Do not replace the rolling bearing.

Failure to follow these instructions can result in equipment damage.

Replacing the Battery for the Multi-Turn Encoder

The multi-turn counting is preserved through power down by the external battery located in the battery compartment.

- Do not disconnect the encoder cable from the battery compartment or the multi-turn information is discarded.
- Replace the battery while the encoder is powered by the drive or the multi-turn information is discarded.

The battery has its manufacturing date printing on it in MMY format. The expiration date for the battery is 3 years after the manufacturing date.

On the following example, the manufacturing date of the battery is June 2016 (0616). The expiration date is June 2019.

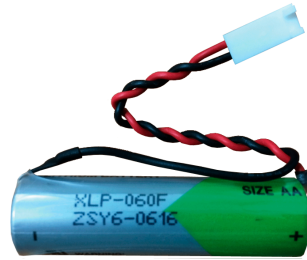

The battery voltage is monitored by the encoder at each power on of the drive.

- An alert Wn749 related to P8-49 Bit 10 is triggered when the measured voltage is in the range 3 ... 3.15 Vdc.
- An error AL576 related to P8-48 Bit 5 is triggered when the measured voltage is under 3 Vdc.

NOTE: After replacing the battery, the error is cleared the next time the drive is powered on (next battery voltage measurement), or when an explicit command is sent to the encoder by setting P8-44 to the value 1.

NOTE: Replace the battery only with the same reference. Refer to the section Encoder Cables and Accessories, page 68.

Lexium 26/28 Multi-Turn Encoder

The purpose of this part is to help you understand the interface between the multi-turn encoder and Lexium 26/28 servo drives in order to be able to operate the system with multi-turn encoder.

Introduction

Overview

An absolute system is used in an application which must preserve the motor position even when the power to the servo system is interrupted.

Lexium 26/28 absolute system includes a Lexium 26/28 series servo drive, an absolute type BCH2 series servo motor, a battery compartment VW3M8BATT, and a battery VW3M9BATT. An absolute encoder in an BCH2 series servo motor will constantly record the actual positions at all times.

When power is removed from the system, the encoder will keep operating because the power will be supplied from battery. Therefore, when the motor shaft is rotated during main power off, the system can still calculate its position to its data memory inside encoder.

Lexium 26/28 multi-turn encoder is a digital, single-turn or multi-turn absolute feedback device. Its major output is the absolute position of the motor shaft in a

turn, represented digitally as a 22-bit word, and number of total revolutions in a 16-bit word, for the multi-turn one.

Single-Turn versus Multi-Turn

A single-turn absolute encoder is capable of encoding a shaft position of the motor within one revolution (or turn). After each power up of the servo system with a single-turn encoder, the absolute position of the shaft in a turn can be obtained.

During run-time, both the drive and the single-turn encoder are capable of counting the number of motor revolutions (the multi-turn counter). However, after power cycle, the revolutions counter is reset for a single-turn system. For example, the multi-turn counter is volatile in a single-turn system.

Single-turn systems are used in machines that do not have a requirement for maintaining position data after a power cycle. In terms of application, it means that homing of the machine after power cycle is acceptable or the system is not required to be homed during operation.

Contrary to single-turn, the multi-turn system has full absolute position information, including the revolutions counter, even if the power is removed. This is used in machines where positioning of the load in a multi-dimensional space is required. In those systems, the homing (or motion calibration) is only acceptable during initial machine calibration and not acceptable after each power cycle. For such systems, the multi-turn encoder is typically used.

In conclusion, the advantage of the multi-turn over a single-turn system is the absence of the need for homing procedure after each system power cycle. The multi-turn system has the absolute position information including the number of revolutions at any time, even after power cycle.

There are two major types of multi-turn encoders: battery backed up and battery-less.

Lexium 26/28 multi-turn encoder is battery backed, meaning the battery is used to maintain the non-volatility of the revolutions counter. As long as the battery is connected and has enough voltage (> 3 V), the multi-turn counter and revolutions counter will remain during the absence of mains power.

Architecture Single-Turn

Motor with a single-turn encoder is connected to the drive according to the following diagram:

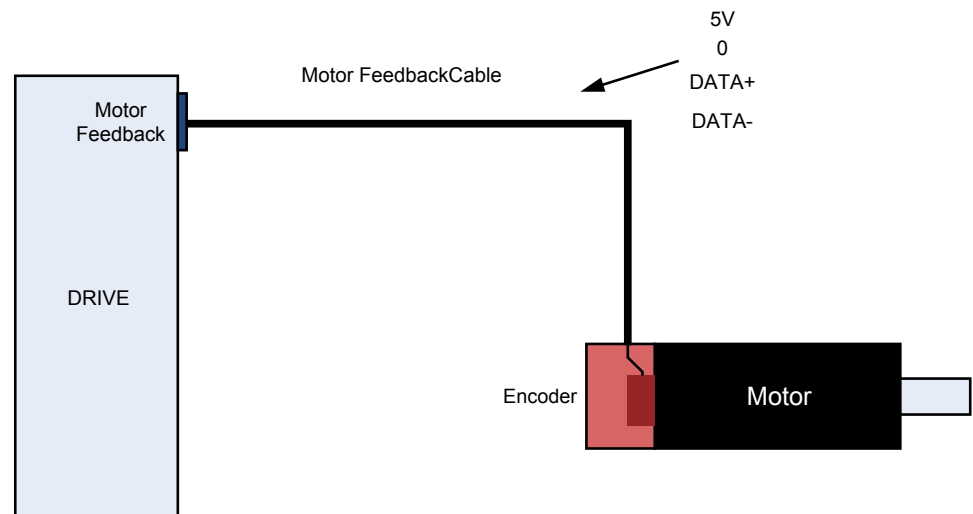

Single-turn encoder is connected to the servo drive over a motor feedback cable. The power to the encoder is supplied over the 5V output of the servo drive. As long as the servo drive is powered, the encoder is powered too, responding with an absolute position in a single revolution.

The servo drive can move the motor and count the number of revolutions. However, right after the 5V output is removed, the multi-turn information is reset. After the power is back again, the encoder will return the information inside one revolution, but the multi-turn counter will be zero.

Architecture Multi-Turn with Battery

Motor with a multi-turn encoder is connected to the drive according to the following diagram:

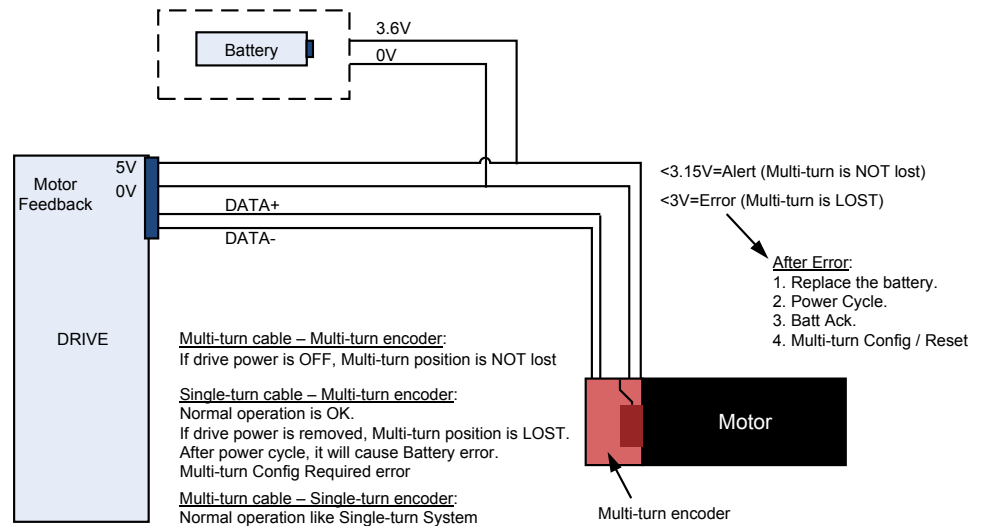

The multi-turn encoder is connected to the servo drive over a battery compartment, which is responsible to supply battery to the multi-turn subsystem in the encoder while power (5V) is off. The battery compartment contains circuitry which controls the switching between the power (5V) and the battery supply automatically.

Since both the battery and the power supply are connected to the same wires in the cable, Lexium 26/28 multi-turn encoder can measure the battery only during power up.

The battery backup is designed to work for at least 3 years. After this period, the battery voltage is expected to drop exponentially. The drop period might take less than a month or maybe more, depending on how much of battery charge has been consumed.

The battery is consumed only when the power supply of 5V is removed, meaning when the servo system mains power is removed. If the motor is at standstill, the power consumption off the battery is relatively low. It grows, however, with rotation velocity. Typically, the motor is not rotated when the servo system is without power. However, the multi-turn system is capable to count the revolutions when powered by battery, while consuming more charge from the battery.

Operation

Functionalities

Reference Position Set

The **Reference Position Set** command is performed in multi-turn motor, only while in the multi-turn mode.

This command can be performed in both (enable and disable) drive states by command (P8-44=2).

The **Reference Position Set** command configures multi-turn encoder and sets new reference position according to the value of P5-78 parameter.

If you implement P8-44=2, then the position equals the reference position as determined by P5-78.

If you implement Homing, then the position equals the home-offset as determined by HOMEOFFSET- (P-0-4020.0.7, usually equals 0).

While a drive is in enable state, this command is performed for all operational modes, excluding **CYCLIC SYNCHRONOUS POSITION** mode.

During the execution of this command, the encoder serial number is read. This serial number is used to check the replacement of the motor or encoder, when a power cycle is performed.

Such as P8-47 ServoSense firmware and hardware versions, P8-45 encoder Feedback type.

When the **Reference Position Set** command is successful, the alert - **reference position not established** (WN753) is cleared, and bit 5 of S-0-0135 in the Statusword is set to 1.

Multi-Turn Battery Acknowledge

The battery error (AL576) is set in the drive, when battery disconnection from the multi-turn encoder is detected after power cycle.

This error automatically produces the **reference position not established** (WN753) alert.

Multi-turn battery Acknowledge command is used to clear **battery voltage is below allowed threshold** error in the multi-turn encoder after battery replacement, and to reset battery error (AL576) in the drive.

This command can be performed by command P8-44=1.

Ignore Multi-Turn Encoder Errors

This feature allows multi-turn encoder work in multi-turn or single-turn mode.

When P5-79 is set to 0, encoder works as multi-turn, when the parameter is set to 1 – as single-turn.

This feature performs the following procedure:

- Get multi-turn encoder error mask by reading special error mask address from the encoder.
- Set new error mask according to the entered value and send command to write updated mask into error mask address in the encoder.

When encoder is set to the single-turn mode, multi-turn errors and alerts are cleared.

Ignore Multi-Turn Encoder Alerts

When encoder is in multi-turn mode, this feature allows to enable or disable multi-turn encoder alerts. Parameter P5-80=1 disables multi-turn encoder alerts.

The alert **MT Encoder rollover** (WN750) is disabled even if the encoder exceeds the counting range. Multi-turn Counter ≤ -32768 or multi-turn Counter ≥ 32767 .

This feature performs the following procedure:

- Get multi-turn encoder alert mask by reading special alert mask address from encoder.
- Set new alert mask according to the parameter value and send command to write updated mask into alert mask address in encoder.

Ignore Homing and Reference Position

This feature allows absolute moving with or without homing for both single-turn and multi-turn encoder and without **Reference Position Set** command for multi-turn encoder. Parameter P5-81=1 blocks the multi-turn encoder alerts and sets the Bit 15 Statusword to 1, when the reference position is not set. The 'isHomed' signal automatic set to on if parameter P5-81=1

Multi-Turn Encoder Position Counter

This feature is used to indicate multi-turn encoder current revolutions.

Special command is sent in the init feedback communication procedure to get encoder's position. An encoder revolutions value can be received by reading the P5-82.

When the encoder is single-turn or is in single-turn mode, the value of position counter always is 0.

Homing Procedure For Multi-Turn Encoder

To set position, drive with multi-turn encoder can independently perform ether homing or reference position set command.

Two main differences for multi-turn encoder:

- Write position to the multi-turn encoder.
- Save homing parameters in NVRAM to reproduce after power cycle.

The homing procedure for multi-turn encoder needs more execution time than for single-turn encoder.

Commands and Parameters

Multi-turn encoder has several commands, which allows managing the errors, multi-turn functionality and battery issues. These commands are encapsulated on the drive side as Parameters. The following table gives a short description of the commands:

Name	Parameters	Description	Use Cases
Battery Acknowledge	P8 – 44 --> 1	Acknowledges the battery event: <ul style="list-style-type: none"> • Battery Down error - AL576. • Low Battery alert - Wn749. 	This command is used to clear the following events: <ul style="list-style-type: none"> • Battery Down error - AL576 • Low Battery alert - Wn749
MT Set Reference Point	P8 – 44 --> 2	This command performs the following: <ul style="list-style-type: none"> • Set reference point. 	This command can be performed in both (enable and disable) drive states, excluding CSP mode When alert Wn753 is indicated.
MT Config /Reset	P8 – 44 --> 3	This command performs the following: <ul style="list-style-type: none"> • Initialize the multi-turn system. • Reset multi-turn revolution counter to 0. 	This command only can be performed in disable drive states. When the multi-turn Config/Reset required error AL577 or Wn750 is indicated.
MULTI_TURN_REF_POSITION	P5-78	Multi-turn reference position in PUU.	After a successful reference set (P8-44=2), this P5-78 position is automatically set at the reference point.
IGNORE_BATTERY_FAULTS	P5-79	Defines whether the drive is to ignore the multi-turn error AL576: <ul style="list-style-type: none"> • Value 0: The masking of the multi-turn error AL576 is inactive. 	When set P5-79=1, multi-turn encoder can be used as single-turn (even with single-turn cable).

Name	Parameters	Description	Use Cases
		<ul style="list-style-type: none"> Value 1: The masking of the multi-turn error AL576 is active. 	
IGNORE_ENCODER_WARNINGS	P5-80	<p>Defines whether the drive is to ignore the multi-turn alert Wn750.</p> <p>Multi-turn counter exceeded the range of 16-bit signed value:</p> <ul style="list-style-type: none"> Multi-turn Counter ≤ -32768 or; Multi-turn Counter ≥ 32767 Value 0: The masking of Wn750 is inactive. Value 1: The masking of Wn750 is active. 	For some applications which will rotate motor in one direction, the alert Wn750 for checking turns number within -32768 ... 32767 can be turned off by parameter P5-80=1.
IGNORE_HOMING_REF_POS	P5-81	<p>Ignore homing and reference position set.</p> <p>Defines whether absolute positioning is allowed without homing/Reference Position Set.</p> <ul style="list-style-type: none"> Value 0: Not allowed. Value 1: Allowed. 	When set P5-81=1, absolute positioning is allowed without homing/ set Reference Point.
MT_ENCODER_POSITION	P5-82	Current position in revolutions.	This parameter is used to monitor the current revolutions of multi-turn.

Errors and Alerts

Error Codes	Description	Remedy
AL571	Reference position operation rejected.	Power-cycle the drive and then perform Homing/ P8-44 = 2.
AL576	The multi-turn encoder battery voltage has dropped under 3 Vdc.	Replace encoder battery. Clear AL576 by command P8-44=1.
AL577	The multi-turn encoder requires an Config/Reset command.	Execute multi-turn Config /Reset (Set Reference Point) by command P8-44=3/2.
AL578	Internal position synchronization error detected between the multi-turn and the single-turn modules.	Restart Drive.
AL579	Encoder is damaged or that a magnetic screw is missing.	Implement factory restore if error happen again replace motor.
Wn749	The multi-turn battery voltage is within the following range: $3\text{ V} < \text{VBAT} < 3.15\text{V}$. Battery voltage has started to drop; but the multi-turn information is still reliable.	Replace encoder battery. Clear Wn749 by command P8-44=1.
Wn750	The multi-turn counter exceeded the range of 16bit signed value. Multi-turn Counter < -32768 Or multi-turn Counter > 32767 .	Execute multi-turn Config /Reset (Set Reference Point) by command P8-44=3/2. For some applications which will rotate motor in one direction, the alert Wn750 for checking turns number within -32768 ... 32767 can be turned off by parameter P5-80=1.
Wn753	Reference position reset.	Execute multi-turn Config /Reset (Set Reference Point) by command P8-44=2 Or Execute a homing procedure.

Initialization Procedure

At the very first time to operate absolute system, there will be an error code AL576 and an alert code Wn753 shown when power on because the initialization procedure has not been done yet. The error and alert will be kept until the initialization procedure is finished. Besides, the AL576 and Wn753 will be displayed when the power from the servo and battery cell box is discontinued that will lead to the coordinate system being reset.

Parameter Settings for first operation:

1. P8-44=1, the AL576 will be cleared.

2. P8-44=3, initialize the multi-turn system.
3. P8-44=2, or execute a homing procedure, the Wn753 will be cleared.

Multi-Turn Methods (LXM28S)

LXM28S + M262 + Multi-Turn

When LXM28S multi-turn is intended to be used with M262 controllers, the following anomalies must be noted:

1. In order to clear a battery error AL576, it needs first the command P8-44=1 on the drive, then execute MC_RESET function block on the controller.
2. In order to perform absolute positioning, the "xIsHomed" flag of the axis needs to be set directly to TRUE on the controller or implement homing 35. For example, `DRV_Lexium28S.Axis.xIsHomed:=TRUE;`
3. After the homing is completed, if the homing mode P-3027.0.12 is modified, the controller needs to wait 4 seconds before the new mode takes effect.
4. Frequently enabling the on/off of the drive will cause an error stop, and further enabling is unsuccessful. Ensure the interval between on/off is 500 ms or more.
5. The position is reset on overflow. The reason for this is that the LXM28S servo runs in one direction, resulting in position overflow, but the M262 does not compensate for the overflow of LXM28S axis position after it is powered on again.

For the modulus axis, the corresponding position value has a change period P, which is related to the modulus, the reduction ratio of the reducer and the position corresponding to each cycle of movement.

When the number of times the motor rotates in one direction is large enough, the position value fed back by the encoder will exceed the limit of dint. Overflow occurs at position 2147483647, jump - 2147483648 (forward), or - 2147483648 to 2147483647 (reverse). Without compensation, the M262 controller does not know how many times it overflows and what the compensation value should be.

However, Machine expert platform has not provided FB `SMC3_PersistPositionSingleturn` similar to CoDeSys platform, so users need to program to realize this function.

`Overflow_compensat (UFB)`

```
//User define FB_compensate position overflow
gvl.overflow_compensate1(
IO_diLastPosition_Persist:= PersistentVars.diLastpositionA1,
IO_iLastP5_82_Persist:= PersistentVars.iP5_82_A1,
IO_diOverflowTurn_Persist:=PersistentVars.diOverflowTurn ,
i_ifAxis:=DRV_Lexium28S ,
i_diDrivePosition:=act_pod_1 ,
i_LrAxisPosition:= DRV_Lexium28S.Axis.lrPosition,
i_iP5_82:=iRead28S_Circle ,
i_xP5_82_OK:=FB_ReadIDN_A1.q_xDone,
i_diGearIn:= 10,
i_diGearOut:=1 ,
i_xDirection:= TRUE,
i_lrPositionResolution:=340 ,
i_LrModulo:=120 ,
i_xPowerEnable:=xA1Enable ,
i_xHomeDoneFlag:=xHome844done ,
q_xPowerEnabled=> ,
q_xRestored=> );
```

Input pin of function block:

Name of Pin	Type of Variable	Description
i_ifAxis	DAL.IF_DeviceAccess	Axis of LXM28S
i_diDrivePosition	DINT	Position feedback which from LXM28S to M262
i_iP5_82	INT	Number of turns of multi-turn P5-82
i_xP5_82_OK	BOOL	The number of reading turns is valid
i_diGearIn	UDINT	Axis config Gear in
i_diGearOut	UDINT	Axis config Gear out
i_lrPositionResolution	LREAL	Axis config PositionResolution
i_LrModulo	LREAL	Axis config of module
i_xDirection	BOOL	Always TRUE
i_xPowerEnable	BOOL	Servo Enable signal
i_xHomeDoneFlag	BOOL	After homing done , this flag bit is TRUE

Input and output pins of function block:

Name of Pin	Type of Variable	Description
IO_diLastPostion_Persist	DINT	It is used to memorize the LXM28S feedback position before power off. PERSISTENT RETAIN variable
IO_iLastP5_82_Persist	INT	It is used to memorize the number of turns before power off. PERSISTENT RETAIN variable
IO_diOverflowTurn_Persist	DINT	It is used to memorize overflow times. PERSISTENT RETAIN variable

Output pin of function block:

Name of Pin	Type of Variable	Description
q_xSercosCommunicationState_OK	BOOL	SercosPhaseState==4, TRUE
q_diPowerOff_EnocoderCounter	UDINT	Number of encoder turns while power off
q_diPowerUp_EnocoderCounter	UDINT	Number of encoder turns while power on cycle
q_xPowerEnabled	BOOL	LXM28S Enable done
q_xRestored	BOOL	Position compensation completion flag bit

Precautions for using function blocks:

1. When the M262 controller resets the initial value or resets persistent variables online, it is necessary to do homing again for all axes.

- During the position, velocity and synchronous movement of LXM28S, ensure that the given speed value does not exceed the maximum speed value set by P1-55. Normally, you will receive an error, but that can be suppressed. Therefore, there is the possibility that the speed will exceed the physical capacity of your application. In addition it may cause a reset of the position information.

▲ WARNING

UNINTENDED EQUIPMENT OPERATION

Maintain speeds during position, velocity and synchronous movement that respect the maximum speed value contained in the parameter P1-55.

Failure to follow these instructions can result in death, serious injury, or equipment damage.

- In the LXM28S of firmware version $\geq 2.78.3$, it is necessary to set the parameter P8-44 to 3 and then 2, while the previous version only needs to set P8-44 to 2.
- In addition, the number of LXM28S turns are signed 16 digits, and its variation range is - 32768 to 32767 turns. In the program, the nonperiodic reading parameter function block is used to read the parameter value of P5-82.

LXM28S + LMC078 + Multi-Turn

The feedback position from LXM28S to LMC078 is a 32-bit signed number. This variable will overflow when it exceeds 2147483647 or less than - 2147483648 (the change direction depends on the rotation direction of the motor).

In addition, the number of LXM28S turns are signed 16 digits, and its variation range is - 32767 to 32768 turns. In the program, the aperiodic parameter reading function block is used to read the parameter value of P5-82.

In view of this situation, the function block `SMC3_PersistPositionSingleturn` provided by CoDeSys is adopted, so as to realize the compensation of multi-turn encoder after position overflow.

SMC3_PersistPositionSingleturn (FB)

This function block serves to persist the axis position of an absolute encoder that as a limited range with a real axis.

It is not only for single-turn encoders but also for multi-turn encoders where the range of the encoder is a power of two and less than 2^{32} .

Both encoders with a range $- 2^k \dots 2^{(k-1)}$ and a range $0 \dots 2^{(k+1)}$ are supported.

Scope	Name	Type	Initial	Comment
Inout	Axis	AXIS_REF_SM3	—	—
	PersistentData	SMC3_PersistPositionSingleturn_Data	—	—
Input	bEnable	BOOL	FALSE	TRUE: Activates the function block, else inactive.
	usiNumberOfAbsoluteBits	USINT	16	Number of bits that are persistent (absolute encoded) [8 ... 32]
Output	bPositionRestored	BOOL	—	TRUE: The position has been restored during the last start-up of the axis.
	bPositionStored	BOOL	—	TRUE: The position has been stored during the last call.
	bBusy	BOOL	—	TRUE: The function block is not idle.

	bError	BOOL	FALSE	TRUE: Error has occurred within the function block.
	eErrorID	SMC_ERROR	SMC_NO_ERROR	Error identification
	eRestoringDiag	SMC3_PersistPositionDiag	SMC3_PersistPositionDiag.SMC3_PPD_RESTORING_OK	Diagnostic information about restoring

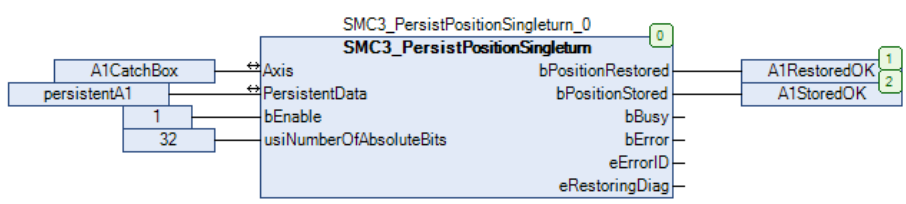
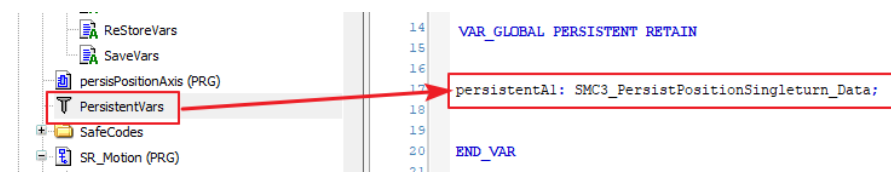
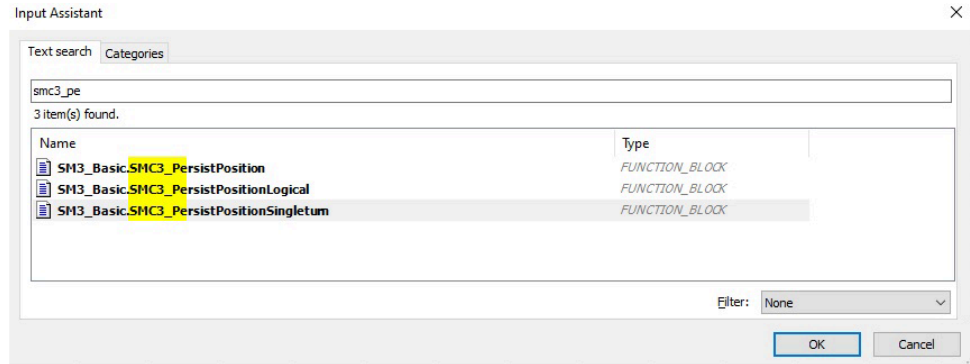

Finally, the POU of persisPositionAxis is called in Motion task to complete programming.

Homing35 limitation

If the motor is always running toward the same direction, the Homing 35 mode does not reset the position to 0 when the rollover value +/-2147483647 (PUU) is reached.

Follow the workaround:

1. Set P8-44 = 3 / IDN P-0-3008.0.44 = 3 (initial multi-turn encoder while servo disable).
2. Set P8-44 = 2 / IDN P-0-3008.0.44 = 2 (set encoder position to 0).
3. Execute MC_SetPosition function block.

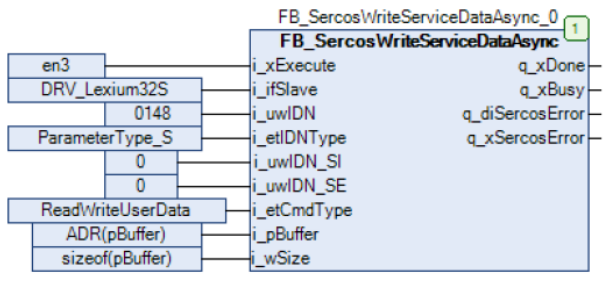

Changing the Motor

Overview

Drive systems may perform unintended movements if unapproved combinations of drive and motor are used. Even if motors are similar, different adjustment of the encoder system may be a source of hazards. Even if the connectors for motor connection and encoder connection match mechanically, this does not imply that the motor is approved for use.

⚠ WARNING

UNINTENDED MOVEMENT

Only use approved combinations of drive and motor.

Failure to follow these instructions can result in death, serious injury, or equipment damage.

Compatibility between Drive and Motor is defined in the Drive / Motor combinations table, page 21.

Changing Motors Procedure

Observe the following procedure when changing motors:

Step	Action
1	Switch off all supply voltages. Verify that no voltages are present.
2	Label all connections and uninstall the product.
3	Note the identification number and the serial number shown on the product nameplate for later identification.
4	Install the new product as per chapter Installation, page 124.
5	Commission the product as per chapter Commissioning, page 134.

If the connected motor is replaced by another approved motor, the new motor is automatically recognized by the drive.

Shipping, Storage, Disposal

Shipping

The product must be protected against shocks during transportation. If possible, use the original packaging for shipping.

Storage

The product may only be stored in spaces where the specified permissible ambient conditions are met.

Protect the product from dust and dirt.

Disposal

The product consists of various materials that can be recycled. Dispose of the product in accordance with local regulations.

Visit www.se.com/green-premium for information and documents on environmental protection as per ISO 14025 such as:

- EoLi (Product End-of-Life Instructions)
- PEP (Product Environmental Profile)

What's in This Part

SERCOS III IDN's	279
SERCOS III Hardware Setup	324

SERCOS III IDN's

What's in This Chapter

SERCOS III IDN's Overview.....	279
P0...P11 Object Group	293
Device-Specific Object Group	317

SERCOS III IDN's Overview

List of SERCOS III Standard IDN's Parameters Supported

Parameter name	Description	Unit	Data type	Parameter address via fieldbus
		Minimum value Factory setting Maximum value	RW Persistent Expert	
<i>S-0-0011</i>	Class 1 diagnostic (C1D) This parameter provides information on detected errors. A class 1 diagnostics error leads to a Quick Stop (with transition to operating state Fault). Type: Hexadecimal - 2 bytes Write access via Sercos: Read only	- 0 0 65535	RO - -	IDN S-0-0011
<i>S-0-0012</i>	Class 2 diagnostic (C2D) This parameter provides information on alerts. Type: Hexadecimal - 2 bytes Write access via Sercos: Read only	- 0 0 65535	RO - -	IDN S-0-0012
<i>S-0-0014</i>	Interface Status This parameter contains the status of the SERCOS interface. Type: Binary - 2 bytes Write access via Sercos: Read only Class name: SCP_VarCFG	- 0 0 16383	RO - -	IDN S-0-0014
<i>S-0-0017</i>	IDN-list of all operation data This parameter contains all procedure commands and parameters supported by the drive. Type: IDN - 4 bytes (variable length) Write access via Sercos: Read only Class name: GDP_Basic	- - - -	RO - -	IDN S-0-0017
<i>S-0-0021</i>	IDN list of invalid operation data for CP2 This parameter contains an IDN list with IDNs which are considered invalid by the drive when it performs the CP3 transition check (S-0-0127). Type: IDN - 4 bytes (variable length) Write access via Sercos: Read only Class name: SCP_VarCFG, SCP_Diag	- - - -	RO - -	IDN S-0-0021
<i>S-0-0022</i>	IDN list of invalid operation data for CP3	- -	RO -	IDN S-0-0022

Parameter name	Description	Unit Minimum value Factory setting Maximum value	Data type RW Persistent Expert	Parameter address via fieldbus
	<p>This parameter contains an IDN list with IDNs which are considered invalid by the drive when it performs the CP4 transition check (S-0-0128).</p> <p>Type: IDN - 4 bytes (variable length)</p> <p>Write access via Sercos: Read only</p> <p>Class name: SCP_VarCFG, SCP_Diag</p>	- -	-	
S-0-0032	<p>Primary Operation Mode</p> <p>This parameter sets the primary operating mode of the drive. The operating mode is started via bits 8, 9 and 10 in the parameter Drive Control (S-0-0134). The active operating mode is indicated by bits 8, 9 and 10 in the status word (S-0-0135).</p> <p>Type: Hexadecimal - 2 bytes</p> <p>Write access via Sercos: CP2, CP3</p>	- 3 3 3	RW - -	IDN S-0-0032
S-0-0033	<p>Secondary Operation Mode 1</p> <p>This parameter sets the secondary operating mode 1 of the drive. The operating mode is started via bits 8, 9 and 10 in the parameter Drive Control (S-0-0134). The active operating mode is indicated by bits 8, 9 and 10 in the status word (S-0-0135).</p> <p>Type: Hexadecimal - 2 bytes</p> <p>Write access via Sercos: CP2, CP3</p>	- 2 2 2	RW - -	IDN S-0-0033
S-0-0034	<p>Secondary Operation Mode 2</p> <p>This parameter sets the secondary operating mode 2 of the drive. The operating mode is started via bits 8, 9 and 10 in the parameter Drive Control (S-0-0134). The active operating mode is indicated by bits 8, 9 and 10 in the status word (S-0-0135).</p> <p>Type: Hexadecimal - 2 bytes</p> <p>Write access via Sercos: CP2, CP3</p>	- 1 1 1	RW - -	IDN S-0-0034
S-0-0047	<p>Position Command Value</p> <p>This parameter contains the target values for operating modes with position target values.</p> <p>Type: Signed decimal - 4 bytes</p> <p>Write access via Sercos: CP2, CP3, CP4</p>	- -2147483648 - 2147483647	RW - -	IDN S-0-0047
S-0-0051	<p>Position Feedback Value 1 (motor feedback)</p> <p>This parameter contains the position data of the motor encoder.</p> <p>Type: Signed decimal - 4 bytes</p> <p>Write access via Sercos: Read only</p>	- -2147483648 - 2147483647	RO - -	IDN S-0-0051
S-0-0099	<p>Reset class 1 diagnostic</p> <p>If this procedure command is received by the drive via the service channel, the detected errors, the error bits and the shut-down mechanism are cleared.</p> <p>Type: Binary - 2 bytes</p> <p>Write access via Sercos: CP2, CP3, CP4</p> <p>Class name: GDP_Basic</p>	- 0 0 7	RW - -	IDN S-0-0099

Parameter name	Description	Unit	Data type	Parameter address via fieldbus
		Minimum value	RW	
		Factory setting	Persistent	
		Maximum value	Expert	
S-0-0127	<p>CP3 transition check</p> <p>This procedure command instructs the drive to verify that all parameters necessary for CP3 have been transferred. If an error is detected, parameter S-0-0021 contains the appropriate IDNs. After correct termination of the command by the master, the master can activate CP3.</p> <p>Type: Binary - 2 bytes</p> <p>Write access via Sercos: CP2, CP3, CP4</p> <p>Class name: SCP_VarCFG</p>	- 0 - 3	RW - -	IDN S-0-0127
S-0-0128	<p>CP4 transition check</p> <p>This procedure command instructs the drive to verify that all parameters necessary for CP4 have been transferred. If an error is detected, parameter S-0-0022 contains the appropriate IDNs. After correct termination of the command by the master, the master can activate CP4.</p> <p>Type: Binary - 2 bytes</p> <p>Write access via Sercos: CP2, CP3, CP4</p> <p>Class name: SCP_VarCFG</p>	- 0 - 3	RW - -	IDN S-0-0128
S-0-0134	<p>Drive Control</p> <p>This parameter contains the control word.</p> <p>Type: Hexadecimal - 2 bytes</p> <p>Write access via Sercos: CP2, CP3, CP4</p>	- 0 - 65535	RW - -	IDN S-0-0134
S-0-0135	<p>Drive Status</p> <p>This parameter contains the status word of the AT. It can be used for diagnostics purposes.</p> <p>Type: Hexadecimal - 2 bytes</p> <p>Write access via Sercos: Read only</p>	- 0 - 65535	RO - -	IDN S-0-0135
S-0-0148	<p>Drive controlled homing procedure command</p> <p>This parameter starts homing with the homing method settings made in the drive objects. See the product manual for details on homing.</p> <p>Type: Unsigned decimal - 2 bytes</p> <p>Write access via Sercos: CP2, CP3, CP4</p>	- 0 - 3	RW - -	IDN S-0-0148
S-0-0187	<p>IDN list of configurable data as producer</p> <p>This parameter contains a list of all IDNs with operation data (feedback values) which can be cyclically processed by the drive.</p> <p>Type: IDN - 4 bytes (variable length)</p> <p>Write access via Sercos: Read only</p> <p>Class name: SCP_VarCFG</p>	- - - -	RO - -	IDN S-0-0187
S-0-0188	<p>IDN list of configurable data as consumer</p> <p>This parameter contains a list of all IDNs with operation data command values) which can be cyclically processed by the drive.</p> <p>Type: IDN - 4 bytes (variable length)</p> <p>Write access via Sercos: Read only</p> <p>Class name: SCP_VarCFG</p>	- - - -	RO - -	IDN S-0-0188

Parameter name	Description	Unit	Data type	Parameter address via fieldbus
		Minimum value	RW	
		Factory setting	Persistent	
		Maximum value	Expert	
S-0-0390	Diagnostic number The operation data of this parameter contains detailed information on the diagnostics event with the highest priority which is currently active in the drive. Type: Hexadecimal - 4 bytes Write access via Sercos: Read only Class name: GDP_Basic	- 0 0 4294967295	RO - -	IDN S-0-0390
S-0-1000.0.0	SCP Type & Version This parameter contains a list of the SERCOS communication capabilities/communication classes and the appropriate version supported by the drive. Type: Hexadecimal - 2 bytes (variable length) Write access via Sercos: Read only Class name: SCP_VarCFG	- - - -	RO - -	IDN S-0-1000.0.0
S-0-1002	Communication Cycle time (tScyc) This parameter specifies the intervals at which the cyclic real-time data is transmitted. Possible values are 1000 µs, 2000 µs and 4000 µs. Type: Unsigned decimal - 4 bytes Write access via Sercos: CP2 Class name: SCP_VarCFG In increments of 0.001 µs.	µs 1000.000 1000.000 4000.000	RW - -	IDN S-0-1002
S-0-1003	Allowed MST losses in CP3/CP4 This parameter specifies the maximum number of successive communication cycles during which a drive is permitted to not receive the MST in CP3 and CP4. Type: Unsigned decimal - 4 bytes Write access via Sercos: CP2 Class name: SCP_VarCFG	- 0 10 65535	RW - -	IDN S-0-1003
S-0-1005	Minimum feedback processing time (t5) This parameter specifies the time required by the drive for receiving and processing actual values (such as encoder or touch probe data) and providing them in ATs. Type: Unsigned decimal - 4 bytes Write access via Sercos: Read only Class name: SCP_Sync In increments of 0.001 µs.	µs - - -	RO - -	IDN S-0-1005
S-0-1006	AT0 transmission starting time (t1) This parameter specifies the nominal time interval between the end of MST and the beginning of AT0. Type: Unsigned decimal - 4 bytes Write access via Sercos: CP2 Class name: SCP_Sync	µs - - -	RW - -	IDN S-0-1006

Parameter name	Description	Unit	Data type	Parameter address via fieldbus
		Minimum value	RW	
		Factory setting	Persistent	
		Maximum value	Expert	
	In increments of 0.001 µs.			
S-0-1007	<p>Synchronisation Time (tSync)</p> <p>This parameter specifies the point in time at which all producer cycle times (producing and consuming connections) in a drive are synchronized. This value is set by the master. It must be less than the value for the synchronization cycle time. The synchronization cycle time is the least common multiple of all producer cycle times (tPcyc) to be synchronized in the network.</p> <p>Type: Unsigned decimal - 4 bytes</p> <p>Write access via Sercos: CP2</p> <p>Class name: SCP_Sync</p> <p>In increments of 0.001 µs.</p>	<p>µs</p> <p>0</p> <p>-</p> <p>4294967.295</p>	<p>RW</p> <p>-</p> <p>-</p>	IDN S-0-1007
S-0-1008	<p>MDT Command value valid time (t3)</p> <p>This parameter determines the point in time at which the drive is permitted to access the new reference values, related to the synchronization time.</p> <p>Type: Unsigned decimal - 4 bytes</p> <p>Write access via Sercos: CP2</p> <p>Class name: SCP_Sync</p> <p>In increments of 0.001 µs.</p>	<p>µs</p> <p>0</p> <p>-</p> <p>4000.000</p>	<p>RW</p> <p>-</p> <p>-</p>	IDN S-0-1008
S-0-1009	<p>Device Control Offset in MDT</p> <p>This parameter specifies the MDT number and the position within the specified MDT for device control. This parameter is transferred by the master to each drive during CP2 and becomes effective in the master and drive in CP3.</p> <p>Type: Hexadecimal - 2 bytes</p> <p>Write access via Sercos: CP2</p> <p>Class name: SCP_VarCFG</p>	<p>-</p> <p>0</p> <p>-</p> <p>1492</p>	<p>RW</p> <p>-</p> <p>-</p>	IDN S-0-1009
S-0-1010	<p>Lengths of MDTs</p> <p>This parameter contains the lengths of the four possible MDTs in octets. These values are required for the initialization of the SERCOS hardware.</p> <p>Type: Unsigned decimal - 2 bytes (variable length)</p> <p>Write access via Sercos: CP2</p> <p>Class name: SCP_VarCFG</p>	<p>-</p> <p>0</p> <p>-</p> <p>1494</p>	<p>RW</p> <p>-</p> <p>-</p>	IDN S-0-1010
S-0-1011	<p>Device Status Offset in AT</p> <p>This parameter specifies the position of the status field of the drive in the AT in octets. This parameter is transferred by the master to each drive during CP2 and becomes effective in the master and drive in CP3.</p> <p>Type: Hexadecimal - 2 bytes</p> <p>Write access via Sercos: CP2</p> <p>Class name: SCP_VarCFG</p>	<p>-</p> <p>0</p> <p>-</p> <p>1492</p>	<p>RW</p> <p>-</p> <p>-</p>	IDN S-0-1011

Parameter name	Description	Unit	Data type	Parameter address via fieldbus
		Minimum value	RW	
		Factory setting	Persistent	
		Maximum value	Expert	
S-0-1012	Length of Ats This parameter contains the lengths of the four possible ATs in octets. These values are required for the initialization of the SERCOS hardware. Type: Unsigned decimal - 2 bytes (variable length) Write access via Sercos: CP2 Class name: SCP_VarCFG	- 0 - 1494	RW - -	IDN S-0-1012
S-0-1013	SVC offset in MDT This parameter specifies the position of the service channel in the MDT for the drive. This parameter is transferred by the master to each drive during CP2 and becomes effective in CP3. Type: Unsigned decimal - 2 bytes Write access via Sercos: CP2 Class name: SCP_VarCFG	- 0 - 1484	RW - -	IDN S-0-1013
S-0-1014	SVC offset in AT This parameter specifies the position of the service channel in the AT for the drive. This parameter is transferred by the master to each drive during CP2 and becomes effective in CP3. Type: Unsigned decimal - 2 bytes Write access via Sercos: CP2 Class name: SCP_VarCFG	- 0 - 1484	RW - -	IDN S-0-1014
S-0-1015	Ring delay This parameter contains the entire ring delay determined by the master. The master assigns this value to the drives. Type: Unsigned decimal - 4 bytes Write access via Sercos: CP2, CP3, CP4 Class name: SCP_Sync In increments of 0.001 μ s.	μ s 0 - 1048.575	RW - -	IDN S-0-1015
S-0-1016	Slave delay (P/S) This parameter contains the slave delay. After the master has assigned the ring delay (S-0-1015) to the slaves, the slaves measure their own delay (SYNCCNT-P/SYNCCNT-S) when the procedure command S-0-1024 is executed. Type: Unsigned decimal - 4 bytes (variable length) Write access via Sercos: Read only Class name: SCP_Sync In increments of 0.001 μ s.	μ s 0 - 4294967.296	RO - -	IDN S-0-1016
S-0-1017	NRT transmission time This parameter contains the NRT transmission time. Type: Hexadecimal - 1 byte (variable length) Write access via Sercos: Read only Class name: SCP_VarCFG	μ s 0 650000 4000000	RO - -	IDN S-0-1017
S-0-1019	MAC Address	-	RO	IDN S-0-1019

Parameter name	Description	Unit	Data type	Parameter address via fieldbus
		Minimum value Factory setting Maximum value	RW Persistent Expert	
	The drive writes its MAC address to this parameter. Type: Unsigned decimal - 1 byte (variable length) Write access via Sercos: CP2, CP3, CP4 Class name: SCP_NRT	- - -	- -	
S-0-1020	Current IP address This parameter contains the IP address of the SERCOS III interface of the drive. The master can change the IP address by writing this parameter. Type: Unsigned decimal - 1 byte (variable length) Write access via Sercos: CP2, CP3, CP4 Class name: SCP_NRT	- - - -	RW - -	IDN S-0-1020
S-0-1021	Subnet Mask This parameter contains the subnet mask. The master can change the subnet mask for IP communication via the NRT channel. Type: Unsigned decimal - 1 byte (variable length) Write access via Sercos: CP2, CP3, CP4 Class name: SCP_NRT	- - - -	RW - -	IDN S-0-1021
S-0-1022	Gateway address This parameter contains the gateway address. The master can change the gateway address for IP communication via the NRT channel. Type: Unsigned decimal - 1 byte (variable length) Write access via Sercos: CP2, CP3, CP4 Class name: SCP_NRT	- - - -	RW - -	IDN S-0-1022
S-0-1023	SYNC jitter This parameter contains the maximum synchronization jitter. The synchronization jitter is used by the drive to calculate the MST window (2 x synchronization jitter). This parameter is transmitted to all drives supporting SCP_Sync. Type: Unsigned decimal - 4 bytes Write access via Sercos: CP2 Class name: SPC_Sync In increments of 0.001 μ s.	μ s - - -	RW - -	IDN S-0-1023
S-0-1024	SYNC delay measuring procedure command This procedure command causes the drive to determine its slave delay (S-0-1016) depending on the ring delay (S-0-1015). Type: Binary - 2 bytes Write access via Sercos: CP2, CP3, CP4 Class name: SCP_Sync	- 0 0 3	RW - -	IDN S-0-1024
S-0-1026	Version of communication hardware This parameter contains the SERCOS III-specific communication hardware identification. Type: Text - 1 byte (variable length)	- - -	RO - -	IDN S-0-1026

Parameter name	Description	Unit Minimum value Factory setting Maximum value	Data type RW Persistent Expert	Parameter address via fieldbus
	Write access via Sercos: Read only Class name: SCP_VarCFG	-		
S-0-1027.0.1	Requested MTU The requested MTU specifies the maximum number of octets that can be sent via the NRT channel by higher layers. Type: Unsigned decimal - 2 bytes Write access via Sercos: CP2 Class name: SCP_NRT	- 46 - 1500	RW - -	IDN S-0-1027.0.1
S-0-1027.0.2	Effective MTU This parameter contains the current MTU. The current MTU is calculated using the parameters S-0-1017 and S-0-1027.0. Type: Unsigned decimal - 2 bytes Write access via Sercos: Read only Class name: SCP_NRT	- 46 - 1500	RO - -	IDN S-0-1027.0.2
S-0-1028	Error counter MST P/S This parameter is an error counter which is incremented if no valid MST is received at port 1 or port 2 during CP 3 and CP4. Type: Unsigned decimal - 2 bytes Write access via Sercos: Read only Class name: SCP_Diag	- 0 0 65535	RO - -	IDN S-0-1028
S-0-1031	Test pin assignment Port 1 & Port 2 This parameter is used to assign communication-related hardware signals to the test pins TS1 and TS2. Type: Binary - 2 bytes Write access via Sercos: CP2, CP3, CP4 Class name: SCP_Diag	- 0 0 3855	RW - -	IDN S-0-1031
S-0-1035	Error counter Port1 and Port2 This parameter is an error counter which counts the detected Ethernet errors. Type: Hexadecimal - 4 bytes Write access via Sercos: CP2, CP3, CP4 Class name: SCP_VarCFG	- 0 0 65535	RW - -	IDN S-0-1035
S-0-1040	SERCOS address This parameter contains the SERCOS device address assigned to the drive. Type: Unsigned decimal - 2 bytes Write access via Sercos: CP2, CP3, CP4 Class name: SCP_VarCFG	- 0 0 511	RW - -	IDN S-0-1040
S-0-1040.0.128	Topology address This parameter contains the topology address of the drive (physical position in the network). This address is independent of the SERCOS address.	- 0 0	RO - -	IDN S-0-1040.0.128

Parameter name	Description	Unit	Data type	Parameter address via fieldbus
		Minimum value	RW	
		Factory setting	Persistent	
		Maximum value	Expert	
	This parameter is a manufacturer-specific extension of the standard parameter. Type: IDN - 2 bytes Write access via Sercos: Read only	511		
<i>S-0-1041</i>	AT Command value valid time (t9) This parameter determines the point in time at which the drive is permitted to access the new reference values from the AT. Type: Unsigned decimal - 4 bytes Write access via Sercos: CP2 Class name: SCP_Sync In increments of 0.001 µs.	µs 0 - 4000.000	RW - -	IDN S-0-1041
<i>S-0-1044</i>	Device Control This parameter contains the control information (for example, topology control, fast-forward, loopback, physical topology, ring, etc.) set by the master and evaluated by the drive. Type: Hexadecimal - 2 bytes Write access via Sercos: Read only Class name: SCP_Diag	- - - -	RO - -	IDN S-0-1044
<i>S-0-1045</i>	Device Status This parameter contains the status information (for example, topology status, fast-forward, loopback, physical topology, ring, etc.) set by the drive and evaluated by the master. Type: Hexadecimal - 2 bytes Write access via Sercos: Read only Class name: SCP_Diag	- - - -	RO - -	IDN S-0-1045
<i>S-0-1046</i>	List of SERCOS addresses in device If a device comprises multiple SERCOS slaves, this parameter contains the SERCOS addresses of the slaves that participate in the communication. Type: Unsigned decimal - 2 bytes (variable length) Write access via Sercos: Read only Class name: SCP_VarCFG	- 1 1 1	RO - -	IDN S-0-1046
<i>S-0-1050.x.01</i>	Connection setup This parameter is used to configure connections. Type: Hexadecimal - 2 bytes Write access via Sercos: CP2 Class name: SCP_VarCFG, SCP_Sync, SCP_WDCon	- 0 8218 65535	RW - -	IDN S-0-1050.x.01
<i>S-0-1050.x.02</i>	Connection Number The connection number is used to identify a connection. The producer and all consumers of the same connection have the same connection number. Type: Unsigned decimal - 2 bytes	- 0 0 65535	RW - -	IDN S-0-1050.x.02

Parameter name	Description	Unit Minimum value Factory setting Maximum value	Data type RW Persistent Expert	Parameter address via fieldbus
	Write access via Sercos: CP2 Class name: SCP_VarCFG			
S-0-1050.x.03	Telegram Assignment This parameter contains the telegram type (MDT or AT), the telegram number and the telegram offset of connection control for this connection. Type: Hexadecimal - 2 bytes Write access via Sercos: CP2 Class name: SCP_VarCFG	- 0 0 15828	RW - -	IDN S-0-1050.x.03
S-0-1050.x.04	Max. Length Of Connection This parameter specifies the maximum length of this connection. Type: Unsigned decimal - 2 bytes Write access via Sercos: Read only Class name: SCP_VarCFG	- 2 2 200	RO - -	IDN S-0-1050.x.04
S-0-1050.x.05	Current length of connection This parameter specifies the current length of this connection. Type: Unsigned decimal - 2 bytes Write access via Sercos: Read only Class name: SCP_VarCFG	- 2 2 200	RO - -	IDN S-0-1050.x.05
S-0-1050.x.06	Configuration List If the connection data is configured via IDNs (type of connection, bit 5-4 = 00, in S-0-1050.x.01), this parameter contains the list of IDNs within this connection. Type: IDN - 4 bytes (variable length) Write access via Sercos: CP2 Class name: SCP_VarCFG	- - - -	RW - -	IDN S-0-1050.x.06
S-0-1050.x.08	Connection Control (C-Con) This parameter contains the image of the control word C-Con of this connection. Type: Unsigned decimal - 4 bytes Write access via Sercos: CP2 Class name: SCP_Diag In increments of 0.001 .	- - - -	RW - -	IDN S-0-1050.x.08
S-0-1050.x.10	Producer Cycle Time This parameter contains the producer cycle time. The producer cycle time should be an integer multiple of the communication cycle time. Type: Unsigned decimal - 2 bytes Write access via Sercos: CP2 Class name: SCP_Sync, SCP_WDCon	µs 31250 1000000 4294967296	RW - -	IDN S-0-1050.x.10
S-0-1050.x.11	Allowed Data Losses	- 1	RO -	IDN S-0-1050.x.11

Parameter name	Description	Unit	Data type	Parameter address via fieldbus
		Minimum value	RW	
		Factory setting	Persistent	
		Maximum value	Expert	
	<p>This parameter specifies the maximum amount of consecutive producer data that may be lost before a connection is closed.</p> <p>Type: Unsigned decimal - 2 bytes</p> <p>Write access via Sercos: Read only</p> <p>Class name: SCP_Sync, SCP_WDCon</p>	1 65535	-	
<i>S-0-1050.x.12</i>	<p>Error Counter Data Losses</p> <p>This parameter is a counter which counts the amount of producer data lost.</p> <p>Type: Hexadecimal - 2 bytes (variable length)</p> <p>Write access via Sercos: Read only</p> <p>Class name: SCP_Sync, SCP_Diag</p>	- 0 0 65535	RO - -	IDN S-0-1050.x.12
<i>S-0-1051.0.0</i>	<p>Image of connection setups</p> <p>This parameter contains the actual state of all the connections of the drive, corresponding to the parameter S-0-1050.x.1.</p> <p>Type: Unsigned decimal - 4 bytes (variable length)</p> <p>Write access via Sercos: CP2</p> <p>Class name: SCP_VarCFG</p> <p>In increments of 0.001 .</p>	- - - -	RW - -	IDN S-0-1051.0.0
<i>S-0-1300.0.02</i>	<p>Vendor Name</p> <p>This parameter contains the vendor-specific name of the device.</p> <p>Type: Text - 1 byte (variable length)</p> <p>Write access via Sercos: Read only</p> <p>Class name: GDP_Id</p>	- - - -	RO - -	IDN S-0-1300.0.02
<i>S-0-1300.0.03</i>	<p>Vendor Code</p> <p>This parameter contains the vendor code. The vendor code is a unique number assigned to each vendor and helps to identify a SERCOS device.</p> <p>Type: Unsigned decimal - 2 bytes</p> <p>Write access via Sercos: Read only</p> <p>Class name: GDP_Basic</p>	- 1 1 1	RO - -	IDN S-0-1300.0.03
<i>S-0-1300.0.04</i>	<p>Device Name</p> <p>This parameter contains the device name published in vendor's price list.</p> <p>Type: Text - 1 byte (variable length)</p> <p>Write access via Sercos: Read only</p> <p>Class name: GDP_Id</p>	- 0 - 255	RO - -	IDN S-0-1300.0.04
<i>S-0-1300.0.05</i>	<p>Vendor Device ID</p> <p>The parameter contains the vendor device ID. The vendor device ID is a unique device ID managed by the vendor; it identifies the component number.</p> <p>Type: Text - 1 byte (variable length)</p> <p>Write access via Sercos: Read only</p>	- 0 - 255	RO - -	IDN S-0-1300.0.05

Parameter name	Description	Unit Minimum value Factory setting Maximum value	Data type RW Persistent Expert	Parameter address via fieldbus
	Class name: GDP_Basic			
S-0-1300.0.08	Hardware Revision This parameter contains the hardware revision of the device. Type: Text - 1 byte (variable length) Write access via Sercos: Read only	- 0 - 255	RO - -	IDN S-0-1300.0.08
S-0-1300.0.09	Software Revision This parameter contains the firmware version of the drive. Type: Text - 1 byte (variable length) Write access via Sercos: Read only	- 0 - 255	RO - -	IDN S-0-1300.0.09
S-0-1300.0.11	Order Number This parameter contains the order number of the drive. Type: Text - 1 byte (variable length) Write access via Sercos: Read only	- - - -	RO - -	IDN S-0-1300.0.11
S-0-1300.0.12	Serial Number This parameter contains the serial number of the drive. Type: Text - 1 byte (variable length) Write access via Sercos: Read only Class name: GDP_Id	- 0 - 255	RO - -	IDN S-0-1300.0.12
S-0-1300.1.09	Software Revision This parameter contains the software version of the SERCOS III Communication Option. Type: Text - 1 byte (variable length) Write access via Sercos: Read only	- 0 - 255	RO - -	IDN S-0-1300.1.09
S-0-1300.1.10	Firmware Loader Revision This parameter contains the revision of the firmware loader or bootloader implemented in the drive. Type: Text - 1 byte (variable length) Write access via Sercos: Read only	- 0 - 255	RO - -	IDN S-0-1300.1.10
S-0-1300.1.11	Reference Number This parameter contains the reference number of the drive. Type: Text - 1 byte (variable length) Write access via Sercos: Read only	- - - -	RO - -	IDN S-0-1300.1.11
S-0-1300.2.09	Software Revision This parameter contains the software version of the FPGA of the SERCOS communication option. Type: Text - 1 byte (variable length) Write access via Sercos: Read only	- 0 - 255	RO - -	IDN S-0-1300.2.09
S-0-1301	List of GDP classes & Version	-	RO	IDN S-0-1301

Parameter name	Description	Unit	Data type	Parameter address via fieldbus
		Minimum value	RW	
		Factory setting	Persistent	
		Maximum value	Expert	
	This parameter contains a list of the generic profile capabilities and the versions supported by the drive. Type: Hexadecimal - 2 bytes (variable length) Write access via Sercos: Read only Class name: GDP_Basic	257 - 5889	- -	
<i>S-0-1302.0.01</i>	FSP Type & Version This parameter contains the function-specific type and the function-dependent version of the resource. Type: Hexadecimal - 4 bytes Write access via Sercos: Read only Class name: GDP_Basic	- 0 - 4294967295	RO - -	IDN S-0-1302.0.01
<i>S-0-1302.0.02</i>	Function groups The operation data of this parameter contains a list of all instanced function groups. Type: IDN - 4 bytes (variable length) Write access via Sercos: Read only Class name: GDP_Basic	- 0 - 4294967295	RO - -	IDN S-0-1302.0.02
<i>S-0-1302.0.03</i>	Application Type The operation data of this parameter contains the type of the sub-device application (for example, main spindle drive, round axis, X axis, etc.). Type: Text - 1 byte (variable length) Write access via Sercos: CP2, CP3, CP4 Class name: GDP_Id	- 0 - 255	RW - -	IDN S-0-1302.0.03

List of Mappable Parameters to RT Data

Overview

Mapping of IDN's to real-time data performed by IDN S-0-1050.X.6 – List of mapped IDN's.

The IDN's that can be mapped to RT data is registered in the following lists:

- IDN S-0-0187 - IDN-list of configurable data as producer (MDT)
- IDN S-0-0188 - IDN-list of configurable data as consumer (AT)

IDN Mappable to RT MDT Data

IDN	Description
<i>S-0-0134.0.0</i>	Drive Control Word (SERCOS III)
<i>S-0-0047.0.0</i>	Position command value (CSP mode)
<i>S-0-0036.0.0</i>	Velocity command value (CSV mode)

IDN	Description
S-0-0080.0.0	Torque command value (CST mode)
S-0-0372.0.0	Halt acceleration bipolar
S-0-0429.0.0	Emergency stop deceleration
P-0-3027.0.13	Velocity Command Value
P-0-3027.0.16	Torque Command Value
P-0-3020.0.3	Position window
P-0-3020.0.23	Velocity offset
P-0-3020.0.24	Torque offset
P-0-3020.0.25	Touch Probe Function
P-0-3025.0.80	SPD Sercos control (CAP1 and CAP2)
P-0-3008.0.17	Setting the digital outputs directly
P-0-3040.0.11	Position at reference point

IDN Mappable to RT AT Data

IDN	Description
S-0-0135.0.0	Drive status (SERCOS III)
S-0-0051.0.0	Position feedback
S-0-0040.0.0	Velocity feedback
S-0-0084.0.0	Torque feedback
P-0-3030.0.32	Velocity feedback
P-0-3030.0.36	Torque feedback
P-0-3020.0.6	Torque demand value
P-0-3020.0.9	DC link circuit voltage
P-0-3010.0.1	Status of the capture inputs
P-0-3010.0.37	Capture input 1 captured position at rising edge
P-0-3010.0.38	Capture input 1 captured position at falling edge
P-0-3010.0.39	Capture input 2 captured position at rising edge
P-0-3010.0.40	Capture input 2 captured position at falling edge
P-0-3010.0.43	Capture input 1 event counter at rising edges
P-0-3010.0.44	Capture input 1 event counter at falling edges
P-0-3010.0.45	Capture input 2 event counter at rising edges
P-0-3010.0.46	Capture input 2 event counter at falling edges
P-0-3025.0.81	SPD Sercos status (CAP1 and CAP2)
P-0-3008.0.1	Physical status of the digital inputs and outputs
P-0-3027.0.4	Active operating mode
P-0-3030.0.18	Current position deviation including dynamic position deviation
P-0-3008.0.15	State of Digital Inputs / Activate Forcing
P-0-3008.0.16	State of Digital Outputs
P-0-3010.0.23	Capture input 1 event counter (Continuous)
P-0-3010.0.24	Capture input 1 event position (Continuous)
P-0-3010.0.25	Capture input 2 event counter (Continuous)

IDN	Description
P-0-3010.0.26	Capture input 2 event position (Continuous)
P-0-3010.0.6	Capture input 1 captured position (one-time)
P-0-3010.0.7	Capture input 2 captured position (one-time)
P-0-3010.0.8	Capture input 1 Event Counter
P-0-3010.0.9	Capture input 2 Event Counter
P-0-3028.0.35	Current Overload
P-0-3028.0.4	Action Status
P-0-3030.0.3	Motor Current
P-0-3030.0.39	Position
S-0-0390.0.0	Diagnostic number

P0...P11 Object Group

P0 Object Group

P0 Object Group

This objects list is also available in P0 - Status parameters, page 171

IDN	Name	Parameter	Object type	Minimum value
			Data type	Factory setting
			Access	Maximum value
P-0-3000.0.0	Firmware Version	P0-00	VAR UINT16 ro	0 - 65535
P-0-3000.0.1	Error code of detected error	P0-01	VAR UINT16 rw	0 - 65535
P-0-3000.0.2	Drive Status Displayed by HMI	P0-02	VAR UINT16 rw	0 0 123
P-0-3000.0.4	FPGA Version	P0-04	VAR UINT16 ro	0 - 65535
P-0-3000.0.8	Operating Hour Meter in Seconds	P0-08	VAR UINT32 ro	0 - 4294967295
P-0-3000.0.9	Status Value 1	P0-09	VAR INT32 ro	-2147483647 - 2147483647
P-0-3000.0.10	Status Value 2	P0-10	VAR INT32 ro	-2147483647 - 2147483647

IDN	Name	Parameter	Object type	Minimum value
			Data type	Factory setting
			Access	Maximum value
P-0-3000.0.11	Status Value 3	P0-11	VAR INT32 ro	-2147483647 - 2147483647
P-0-3000.0.12	Status Value 4	P0-12	VAR INT32 ro	-2147483647 - 2147483647
P-0-3000.0.13	Status Value 5	P0-13	VAR INT32 ro	-2147483647 - 2147483647
P-0-3000.0.17	Indicate status value 1	P0-17	VAR UINT16 rw	0 0 123
P-0-3000.0.18	Indicate status value 2	P0-18	VAR UINT16 rw	0 0 123
P-0-3000.0.19	Indicate status value 3	P0-19	VAR UINT16 rw	0 0 123
P-0-3000.0.20	Indicate status value 4	P0-20	VAR UINT16 rw	0 0 123
P-0-3000.0.21	Indicate status value 5	P0-21	VAR UINT16 rw	0 0 123
P-0-3000.0.25	Parameter Mapping 1	P0-25	VAR UINT32 rw	0 - 4294967295
P-0-3000.0.26	Parameter Mapping 2	P0-26	VAR UINT32 rw	0 - 4294967295
P-0-3000.0.27	Parameter Mapping 3	P0-27	VAR UINT32 rw	0 - 4294967295
P-0-3000.0.28	Parameter Mapping 4	P0-28	VAR UINT32 rw	0 - 4294967295
P-0-3000.0.29	Parameter Mapping 5	P0-29	VAR UINT32 rw	0 - 4294967295
P-0-3000.0.30	Parameter Mapping 6	P0-30	VAR UINT32 rw	0 - 4294967295

IDN	Name	Parameter	Object type	Minimum value
			Data type	Factory setting
			Access	Maximum value
P-0-3000.0.31	Parameter Mapping 7	P0-31	VAR UINT32 rw	0 - 4294967295
P-0-3000.0.32	Parameter Mapping 8	P0-32	VAR UINT32 rw	0 - 4294967295
P-0-3000.0.35	Block Data Read/Write P0-35...P0-42 1	P0-35	VAR UINT32 rw	0 0 4294967295
P-0-3000.0.36	Block Data Read/Write P0-35...P0-42 2	P0-36	VAR UINT32 rw	0 0 4294967295
P-0-3000.0.37	Block Data Read/Write P0-35...P0-42 3	P0-37	VAR UINT32 rw	0 0 4294967295
P-0-3000.0.38	Block Data Read/Write P0-35...P0-42 4	P0-38	VAR UINT32 rw	0 0 4294967295
P-0-3000.0.39	Block Data Read/Write P0-35...P0-42 5	P0-39	VAR UINT32 rw	0 0 4294967295
P-0-3000.0.40	Block Data Read/Write P0-35...P0-42 6	P0-40	VAR UINT32 rw	0 0 4294967295
P-0-3000.0.41	Block Data Read/Write P0-35...P0-42 7	P0-41	VAR UINT32 rw	0 0 4294967295
P-0-3000.0.42	Block Data Read/Write P0-35...P0-42 8	P0-42	VAR UINT32 rw	0 0 4294967295
P-0-3000.0.46	State of Signal Output Functions	P0-46	VAR UINT16 ro	0 - 65535
P-0-3000.0.47	Number of Last Alert	P0-47	VAR UINT16 ro	0 - 65535

P1 Object Group

P1 Object Group

This objects list is also available in P1 - Basic parameters, page 177

IDN	Name	Parameter	Object type	Minimum value
			Data type	Factory setting
			Access	Maximum value
P-0-4001.0.1	Operating Mode and Direction of Rotation	P1-01	VAR	32
			UINT16	153
			rw	4505
P-0-4001.0.2	Velocity and Torque Limitations Activation/ Deactivation	P1-02	VAR	0
			UINT16	0
			rw	17
P-0-4001.0.3	Polarity of Pulse Outputs	P1-03	VAR	0
			UINT16	0
			rw	16
P-0-4001.0.7	Limit Switch Fault Reaction	P1-07	VAR	0
			UINT16	1
			rw	1
P-0-4001.0.9	Velocity Limitation 1	P1-09	VAR	-60000
			INT32	10000
			rw	60000
P-0-4001.0.10	Velocity Limitation 2	P1-10	VAR	-60000
			INT32	20000
			rw	60000
P-0-4001.0.11	Velocity Limitation 3	P1-11	VAR	-60000
			INT32	30000
			rw	60000
P-0-4001.0.12	Torque Limitation 1	P1-12	VAR	-300
			INT16	100
			rw	300
P-0-4001.0.13	Torque Limitation 2	P1-13	VAR	-300
			INT16	100
			rw	300
P-0-4001.0.14	Torque Limitation 3	P1-14	VAR	-300
			INT16	100
			rw	300
P-0-4001.0.15	Mains Phase Monitoring - Response to Missing Mains Phase	P1-15	VAR	0
			UINT16	0
			rw	2
P-0-3001.0.16	Mains Phase Monitoring - Fault Reset	P1-16	VAR	0
			UINT16	0
			rw	1
P-0-3001.0.17	Mains Phase Monitoring - Type	P1-17	VAR	0
			UINT16	0
			rw	2
P-0-4001.0.19	Active Disable - Delay Time Power Stage	P1-19	VAR	0
			UINT16	0
			rw	6500

IDN	Name	Parameter	Object type	Minimum value
			Data type	Factory setting
			Access	Maximum value
P-0-4001.0.20	Current Limit During Quick Stop	P1-20	VAR INT16 rw	1 1000 1000
P-0-4001.0.21	Status of Foldback Current Drive	P1-21	VAR UINT16 ro	0 - 1
P-0-4001.0.22	Foldback Current Limit - Drive	P1-22	VAR UINT32 ro	0 - 30000
P-0-4001.0.23	Current Monitoring Drive - Detected Error Threshold Foldback Current	P1-23	VAR UINT32 rw	0 - 30000
P-0-4001.0.24	Current Monitoring Drive - Alert Threshold Foldback Current	P1-24	VAR UINT32 rw	0 - 30000
P-0-4001.0.25	Reserved	P1-25	VAR UINT32 rw	- - -
P-0-4001.0.26	Foldback Current Limit - Motor	P1-26	VAR UINT32 ro	0 - 30000
P-0-3001.0.27	Motor Current Monitoring - Detected Error Threshold Foldback Current	P1-27	VAR UINT32 rw	0 - 30000
P-0-4001.0.28	Motor Current Monitoring - Alert Threshold Foldback Current	P1-28	VAR UINT32 rw	0 - 30000
P-0-4001.0.29	DC Bus Overvoltage Monitoring - Threshold	P1-29	VAR UINT16 ro	- - -
P-0-4001.0.30	Commutation Monitoring - Maximum Counter Value	P1-30	VAR UINT16 rw	0 0 0
P-0-4001.0.32	Stop Method	P1-32	VAR UINT16 rw	0 0 32
P-0-4001.0.34	Acceleration Period	P1-34	VAR UINT16 rw	6 30 65500
P-0-4001.0.35	Deceleration Period	P1-35	VAR UINT16 rw	6 30 65500

IDN	Name	Parameter	Object type	Minimum value
			Data type	Factory setting
			Access	Maximum value
P-0-4001.0.37	Ratio of Load Inertia to Motor Inertia	P1-37	VAR UINT32 rw	0 10 20000
P-0-3006.0.27	Signal Output Function ZSPD	P1-38	VAR INT32 rw	0 100 2000
P-0-4001.0.39	Signal Output Function TSPD - Velocity	P1-39	VAR UINT32 rw	0 3000 5000
P-0-3005.0.7	ON Delay Time of Holding Brake	P1-42	VAR UINT16 rw	0 0 1000
P-0-4001.0.44	Electronic Gear Ratio - Numerator 1	P1-44	VAR UINT32 rw	1 1 536870911
P-0-4001.0.45	Electronic Gear Ratio - Denominator	P1-45	VAR UINT32 rw	1 131072 2147483647
P-0-4001.0.46	Encoder Simulation Resolution	P1-46	VAR INT32 rw	- 2048 -
P-0-3001.0.52	Braking Resistor - Resistance	P1-52	VAR INT16 rw	-1 - 32767
P-0-3001.0.53	Braking Resistor - Power	P1-53	VAR INT16 rw	-1 - 32767
P-0-3001.0.54	Signal Output Function TPOS - Trigger Value	P1-54	VAR UINT32 rw	0 1311 1280000
P-0-3017.0.16	Maximum Velocity - User-Defined	P1-55	VAR UINT32 rw	10 - 6000
P-0-3001.0.57	Torque Monitoring - Torque Value	P1-57	VAR UINT16 rw	0 0 300
P-0-3001.0.58	Torque Monitoring - Time Value	P1-58	VAR UINT16 rw	1 1 1000
P-0-3001.0.59	S Curve Filter for Profile Velocity	P1-59	VAR UINT32 rw	0 0 255875

IDN	Name	Parameter	Object type	Minimum value
			Data type	Factory setting
			Access	Maximum value
P-0-3001.0.60	Commutation Monitoring - Time Threshold	P1-60	VAR UINT16 rw	0 0 3000
P-0-3001.0.61	Commutation Monitoring - Velocity Threshold	P1-61	VAR UINT32 rw	0 600 60000
P-0-3001.0.62	Motor Overtemperature Monitoring - Response	P1-62	VAR UINT16 rw	0 0 5
P-0-3001.0.63	Motor Overtemperature Monitoring - Delay Time	P1-63	VAR UINT16 rw	0 30 300
P-0-3001.0.64	Undervoltage Monitoring - Response	P1-64	VAR UINT16 rw	0 0 3
P-0-3001.0.66	Status of Foldback Current Motor	P1-66	VAR UINT16 ro	0 - 1
P-0-3001.0.67	Undervoltage Monitoring - Delay Time	P1-67	VAR UINT16 rw	0 30 300
P-0-3001.0.68	Active Disable - Deceleration Ramp	P1-68	VAR UINT16 rw	6 30 65500
P-0-3001.0.69	Disable - Deceleration Time	P1-69	VAR UINT16 rw	0 0 6500
P-0-3001.0.71	Braking Resistor - Maximum Time in Braking	P1-71	VAR UINT16 rw	10 40 100
P-0-3001.0.72	Braking Resistor Overload Monitoring - Response	P1-72	VAR UINT16 rw	0 0 1
P-0-4001.0.78	User-Defined Maximum Current	P1-78	VAR UINT32 rw	- - -
P-0-3017.0.12	Maximum Current	P1-79	VAR UINT32 ro	- - -
P-0-3001.0.80	Maximum Peak Current	P1-80	VAR UINT32 ro	- - -

IDN	Name	Parameter	Object type	Minimum value
			Data type	Factory setting
			Access	Maximum value
P-0-3001.0.81	Nominal Current	P1-81	VAR UINT32 ro	- - -
P-0-3001.0.82	Velocity limitation for operating mode Profile Torque	P1-82	VAR UINT16 rw	0 0 3
P-0-3001.0.84	Configured motor type	P1-84	VAR UINT32 rw	0 - 2147483647
P-0-3001.0.85	Torque Limit For Modes	P1-85	VAR UINT16 rw	0 0 3
P-0-3017.0.13	Quick Stop - Maximum Current	P1-87	VAR UINT32 rw	- 0 P1-79

P2 Object Group

P2 Object Group

This objects list is also available in P2 - Extended parameters, page 186

IDN	Name	Parameter	Object type	Minimum value
			Data type	Factory setting
			Access	Maximum value
P-0-4002.0.1	Gain Switching - Rate for Position Loop	P2-01	VAR UINT16 rw	10 100 500
P-0-4002.0.5	Gain Switching - Rate for Velocity Loop	P2-05	VAR UINT16 rw	10 100 500
P-0-3002.0.8	Factory Reset / Save Parameters / Activation of Forcing of Outputs	P2-08	VAR UINT16 rw	0 0 406
P-0-3002.0.9	Debounce Time - Inputs	P2-09	VAR UINT16 rw	0 2 20
P-0-3007.0.1	Signal Input Function for DI1	P2-10	VAR UINT16 rw	0 256 326
P-0-3007.0.2	Signal Input Function for DI2	P2-11	VAR UINT16 rw	0 256 326

IDN	Name	Parameter	Object type	Minimum value
			Data type	Factory setting
			Access	Maximum value
P-0-3007.0.3	Signal Input Function for DI3	P2-12	VAR UINT16 rw	0 256 326
P-0-3007.0.4	Signal Input Function for DI4	P2-13	VAR UINT16 rw	0 256 326
P-0-3007.0.5	Signal Input Function for DI5	P2-14	VAR UINT16 rw	0 36 326
P-0-3007.0.6	Signal Input Function for DI6	P2-15	VAR UINT16 rw	0 34 326
P-0-3007.0.7	Signal Input Function for DI7	P2-16	VAR UINT16 rw	0 35 326
P-0-3007.0.8	Signal Input Function for DI8	P2-17	VAR UINT16 rw	0 33 326
P-0-3007.0.9	Signal Output Function for DO1	P2-18	VAR UINT16 rw	0 257 311
P-0-3007.0.10	Signal Output Function for DO2	P2-19	VAR UINT16 rw	0 256 311
P-0-3007.0.11	Signal Output Function for DO3	P2-20	VAR UINT16 rw	0 256 311
P-0-3007.0.12	Signal Output Function for DO4	P2-21	VAR UINT16 rw	0 256 311
P-0-3007.0.14	Signal Output Function for OCZ	P2-23	VAR UINT16 rw	0 64 311
P-0-4002.0.24	Debounce Time - Fast Inputs	P2-24	VAR UINT16 rw	0 50 100
P-0-4002.0.27	Gain Switching - Conditions and Type	P2-27	VAR UINT16 rw	0 0 24
P-0-4002.0.29	Gain Switching - Comparison Value	P2-29	VAR UINT32 rw	0 1280000 3840000

IDN	Name	Parameter	Object type	Minimum value
			Data type	Factory setting
			Access	Maximum value
P-0-4002.0.30	Auxiliary Functions	P2-30	VAR	-8
			INT16	0
			rw	8
P-0-4002.0.31	Autotuning Optimization Value Threshold	P2-31	VAR	100
			UINT32	1000
			rw	10000
P-0-4002.0.32	Autotuning	P2-32	VAR	0
			UINT16	0
			rw	56
P-0-4002.0.34	Velocity Monitoring - Threshold Value	P2-34	VAR	0
			UINT32	50000
			rw	60000
P-0-3006.0.62	Position Deviation Monitoring - Threshold Value	P2-35	VAR	1
			UINT32	384000
			rw	12800000
P-0-3002.0.50	Signal Input Function CLRPOS - Trigger	P2-50	VAR	0
			UINT16	0
			rw	1
P-0-3002.0.65	Special Function 1	P2-65	VAR	0
			UINT16	512
			rw	65472
P-0-3002.0.66	Special Function 2	P2-66	VAR	0
			UINT16	0
			rw	4
P-0-3002.0.68	Auto-Enable and Automatic Hardware Limit Switch Fault Reset	P2-68	VAR	0
			UINT16	256
			rw	273

P3 Object Group

P3 Object Group

Part of this objects list is also available in P3 - Communication parameters, page 193

IDN	Name	Parameter	Object type	Minimum value
			Data type	Factory setting
			Access	Maximum value
P-0-3003.0.0	Device Address Modbus	P3-00	VAR	1
			UINT16	127
			rw	247
P-0-3003.0.1	Transmission Rate for Integrated Fieldbus and Modbus	P3-01	VAR	0
			UINT16	2
			rw	5
P-0-3003.0.2	Modbus Connection Settings	P3-02	VAR	6
			UINT16	7
			rw	9
P-0-3003.0.3	Detected Modbus Communication Errors - Handling	P3-03	VAR	0
			UINT16	0
			rw	1
P-0-3003.0.4	Modbus Connection Monitoring	P3-04	VAR	0
			UINT16	0
			rw	20000
P-0-3003.0.5	Device Address Integrated Fieldbus	P3-05	VAR	0
			UINT16	0
			rw	127
P-0-3003.0.6	Digital Inputs - Forcing Settings	P3-06	VAR	0
			UINT16	0
			rw	2047
P-0-3003.0.7	Modbus Response Delay Time	P3-07	VAR	0
			UINT16	0
			rw	1000
P-0-3003.0.8	Fieldbus Protocol	P3-08	VAR	0
			UINT16	2
			rw	4
P-0-3003.0.30	Internal Limit for Bit 11 <i>Status Word S-0-0135</i> .	P3-30	VAR	0
			UINT16	0
			rw	11
P-0-3003.0.31	Settings for operating state Quick Stop	P3-31	VAR	-2
			INT16	6
			rw	7
P-0-3003.0.32	Automatic operating state transition from Switch On Disabled to Ready To Switch On	P3-32	VAR	0
			UINT16	0
			rw	1
P-0-3003.0.33	Fieldbus Communication Status	P3-33	VAR	0
			INT16	-
			r	6

P4 Object Group

P4 Object Group

Part of this objects list is also available in P4 - Diagnostics parameters, page 196

IDN	Name	Parameter	Object type	Minimum value
			Data type	Factory setting
			Access	Maximum value
P-0-3004.0.0	Error History - Error Number of the Most Recently Detected Error n	P4-00	VAR UINT16 rw	0 - 65535
P-0-3004.1.1	Error History - Error Number of the Most Recently Detected Error n - 1	P4-01	VAR UINT16 ro	0 - 65535
P-0-4004.0.2	Error History -Error Number of the Most Recently Detected Error n - 2	P4-02	VAR UINT16 ro	0 - 65535
P-0-4004.0.3	Error History - Error Number of the Most Recently Detected Error n - 3	P4-03	VAR UINT16 ro	0 - 65535
P-0-4004.0.4	Error History - Error Number of the Most Recently Detected Error n - 4	P4-04	VAR UINT16 ro	0 - 65535
P-0-4004.0.5	Jog Velocity	P4-05	VAR UINT32 rw	0 20 5000
P-0-3004.0.6	Forcing Matrix of Digital Outputs	P4-06	VAR UINT16 rw	0 0 255
P-0-3008.0.15	State of Digital Inputs / Activate Forcing	P4-07	VAR UINT16 rw	0 - 255
P-0-4004.0.8	Status of HMI Keypad	P4-08	VAR UINT16 ro	0 0 255
P-0-3008.0.16	State of Digital Outputs	P4-09	VAR UINT16 ro	0 - 63
P-0-4004.0.10	Clear Error History	P4-10	VAR UINT16 rw	0 0 0
P-0-3004.0.24	Undervoltage Monitoring - Threshold Value	P4-24	VAR UINT16 rw	140 160 190

IDN	Name	Parameter	Object type	Minimum value
			Data type	Factory setting
			Access	Maximum value
P-0-3004.0.25	Safety Function STO - Status	P4-25	VAR	0
			UINT16	-
			ro	1
P-0-3004.0.26	Forceable digital outputs	P4-26	VAR	15
			UINT16	15
			ro	15
P-0-3004.0.27	Digital output force mask	P4-27	VAR	0
			UINT16	0
			rw	15
P-0-3004.0.28	Digital output force value	P4-28	VAR	0
			UINT16	0
			rw	15
P-0-3004.0.29	Motor Load Period Time	P4-29	VAR	1
			UINT32	5000
			rw	100000

P5 Object Group

P5 Object Group

This objects list is also available in P5 - Motion settings parameters, page 199

IDN	Name	Parameter	Object type	Minimum value
			Data type	Factory setting
			Access	Maximum value
P-0-3005.0.0	Firmware Revision	P5-00	VAR	0
			UINT16	-
			ro	65535
P-0-4005.0.8	Positive Software Limit Switch - Position	P5-08	VAR	-2147483647
			INT32	134217727
			rw	2147483647
P-0-4005.0.9	Negative Software Limit Switch - Position	P5-09	VAR	-2147483647
			INT32	-134217727
			rw	2147483647
P-0-3005.2.11	Software Limit Switches - Hysteresis Value	P5-11	VAR	0
			UINT16	3556
			rw	35555
P-0-4005.0.12	Touch Probe Input 1 - Stable Level Duration	P5-12	VAR	2
			UINT16	5
			rw	32
P-0-4005.0.13	Position Limiting Mode	P5-13	VAR	0
			UINT16	2
			rw	3

IDN	Name	Parameter	Object type	Minimum value
			Data type	Factory setting
			Access	Maximum value
P-0-3006.0.42	Motion Profile for Torque - Slope	P5-14	VAR UINT32 rw	1 100000 30000000
P-0-3006.0.44	Motion Profile for Torque - Activation	P5-15	VAR UINT16 rw	0 0 1
P-0-4005.0.16	Encoder Increments in PUU	P5-16	VAR INT32 rw	-2147483647 0 2147483647
P-0-4005.0.18	External Encoder (Pulses)	P5-18	VAR INT32 ro	-2147483648 - 2147483647
P-0-3005.0.21	Deceleration Ramp - Detected Transmission Error	P5-21	VAR UINT16 rw	6 50 65500
P-0-4005.0.22	Deceleration Ramp - Position Overflow	P5-22	VAR UINT16 rw	6 30 65500
P-0-3005.0.23	Deceleration Ramp - Triggering of Negative Software Limit Switch	P5-23	VAR UINT16 rw	6 50 65500
P-0-3005.0.24	Deceleration Ramp - Triggering of Positive Software Limit Switch	P5-24	VAR UINT16 rw	6 50 65500
P-0-4005.0.25	Deceleration Ramp - Triggering of Negative Hardware Limit Switch	P5-25	VAR UINT16 rw	6 30 65500
P-0-4005.0.26	Deceleration Ramp - Triggering of Positive Hardware Limit Switch	P5-26	VAR UINT16 rw	6 30 65500
P-0-4005.0.35	Touch Probes Polarity	P5-35	VAR UINT16 ro	0 - 3
P-0-4005.0.36	Touch Probe Input 1 - Captured Position SERCOS III Units	P5-36	VAR INT32 ro	-2147483647 0 2147483647
P-0-4005.0.37	Touch Probe Input 1 - Captured Position	P5-37	VAR INT32 ro	-2147483647 0 2147483647
P-0-4005.0.38	Touch Probe Input 1 - Event Counter	P5-38	VAR UINT16 ro	0 0 65535

IDN	Name	Parameter	Object type	Minimum value
			Data type	Factory setting
			Access	Maximum value
P-0-4005.0.39	Touch Probe Input 1 - Configuration	P5-39	VAR UINT16 rw	0 0 257
P-0-3005.0.56	Touch Probe Input 2 - Captured Position SERCOS III Units	P5-56	VAR INT32 ro	-2147483647 0 2147483647
P-0-3005.0.57	Touch Probe Input 2 - Captured Position	P5-57	VAR INT32 ro	-2147483647 0 2147483647
P-0-3005.0.58	Touch Probe Input 2 - Event Counter	P5-58	VAR UINT16 ro	0 0 65535
P-0-3005.0.59	Touch Probe Input 2 - Configuration	P5-59	VAR UINT16 rw	0 0 257
P-0-3005.0.76	Move Offset When Homing	P5-76	VAR UINT16 rw	0 0 1
P-0-3005.0.77	Touch Probe Input 2 - Stable Level Duration	P5-77	VAR UINT16 rw	2 5 32

P8 Object Group

P8 Object Group

This objects list is also available in P8 - Control loops parameters, page 205

IDN	Name	Parameter	Object type	Minimum value
			Data type	Factory setting
			Access	Maximum value
P-0-3008.0.0	Derivative Gain	P8-00	VAR UINT32 rw	0 800 20000
P-0-3008.1.1	Integral Gain	P8-01	VAR UINT32 rw	0 100 2000
P-0-3008.0.2	Derivative-Integral Gain	P8-02	VAR UINT32 rw	0 400 4000
P-0-3008.0.3	Proportional Gain	P8-03	VAR UINT32 rw	0 300 4000

IDN	Name	Parameter	Object type	Minimum value
			Data type	Factory setting
			Access	Maximum value
P-0-3008.0.4	Global Gain	P8-04	VAR UINT32 rw	100 500 3000
P-0-3008.0.5	LTN Spring Filter	P8-05	VAR UINT16 rw	10 7000 7000
P-0-3008.0.6	Anti-Vibration Gain	P8-06	VAR UINT32 rw	0 0 10000
P-0-3008.0.7	Pe filter	P8-07	VAR UINT32 rw	0 0 99000
P-0-3008.0.8	Anti-Vibration Filter	P8-08	VAR UINT32 rw	50 4000 4000
P-0-3008.0.9	Pe filter	P8-09	VAR UINT32 rw	50 4000 8000
P-0-4008.0.10	Ratio of Load Inertia to Motor Inertia for Anti-Vibration	P8-10	VAR UINT32 rw	0 0 6000
P-0-4008.0.11	NL Anti-Resonance Filter Divider	P8-11	VAR UINT32 rw	1 200 10000
P-0-4008.0.12	Anti-Resonance Sharpness	P8-12	VAR UINT16 rw	10 500 10000
P-0-4008.0.13	Pe Sharpness	P8-13	VAR UINT16 rw	10 500 10000
P-0-3008.0.14	Current Filter Damping	P8-14	VAR UINT16 rw	0 0 100
P-0-3008.1.15	Current Filter Low Pass Filter Rise Time	P8-15	VAR UINT16 rw	0 300 3000
P-0-3008.1.16	Current Filter - Second Notch Filter Bandwidth	P8-16	VAR UINT16 rw	0 0 500
P-0-3008.1.17	Current Filter - Second Notch Filter Center	P8-17	VAR UINT16 rw	5 100 1800

IDN	Name	Parameter	Object type	Minimum value
			Data type	Factory setting
			Access	Maximum value
P-0-4008.0.18	Current Filter - Notch Filter Bandwidth	P8-18	VAR UINT16 rw	0 0 500
P-0-4008.0.19	Current Filter - Notch Filter Center	P8-19	VAR UINT16 rw	5 100 1800
P-0-3008.0.20	Elasticity Compensation	P8-20	VAR UINT32 rw	0 50000 50000
P-0-3008.0.21	Spring Deceleration Ratio	P8-21	VAR UINT16 rw	0 1000 2000
P-0-4008.0.32	S-Curve Setting for Profile Position	P8-32	VAR UINT32 rw	25 400 25600
P-0-4008.0.33	Low Pass Filter Setting for Profile Position	P8-33	VAR UINT32 rw	1 5000 500000
P-0-4008.0.34	Smoothing Filter for Profile Position	P8-34	VAR UINT16 rw	0 2 2
P-0-4008.0.35	Type of Velocity Control and Type of position Control	P8-35	VAR UINT16 rw	5 519 16385
P-0-4008.0.36	Pe filter 3	P8-36	VAR UINT32 rw	0 0 6000
P-0-4008.0.37	Pe filter 3	P8-37	VAR UINT32 rw	50 4000 8000
P-0-4008.0.38	Pe filter 3	P8-38	VAR UINT32 rw	200 1000 10000
P-0-3008.0.39	Gravity Compensation	P8-39	VAR INT16 rw	- 0 -
P-0-3008.0.40	LTN AFF	P8-40	VAR UINT16 rw	0 0 200
P-0-3008.0.41	Pe Sharpness	P8-41	VAR UINT16 rw	10 200 10000

IDN	Name	Parameter	Object type	Minimum value
			Data type	Factory setting
			Access	Maximum value
P-0-3008.0.42	Homing Incorrect Information	P8-42	VAR UINT32 ro	0 - 4294967295
P-0-3008.0.43	ZSPD Low Pass Filter Value	P8-43	VAR UINT16 rw	10 1000 1000
P-0-3008.0.44	Send commands to multi-turn encoder	P8-44	VAR UINT16 rw	0 - 2
P-0-3008.0.45	Feedback type	P8-45	VAR UINT16 ro	0 - 2
P-0-3008.0.46	Encoder temperature	P8-46	VAR INT16 ro	- - -
P-0-3008.0.47	Encoder firmware and hardware versions	P8-47	VAR UINT32 ro	0 - 4294967295
P-0-3008.0.48	Encoder active errors	P8-48	VAR UINT32 ro	0 - 4294967295
P-0-3008.0.49	Encoder active alerts	P8-49	VAR UINT32 ro	0 - 4294967295
P-0-3008.0.51	Speed Observer Mode	P8-51	VAR UINT16 rw	0 0 3
P-0-3008.0.53	Position Linear Controller Proportional Gain, page 214	P8-53	VAR UINT16 rw	0 300 12000
P-0-3008.0.54	Position Velocity Feedforward	P8-54	VAR INT32 rw	-2000 500 2000
P-0-3008.0.55	Position Acceleration Feedforward	P8-55	VAR INT32 rw	-20000 0 20000
P-0-3008.0.56	Position Acceleration Feedforward to Current Loop	P8-56	VAR INT32 rw	-20000 0 20000
P-0-3008.0.57	Velocity Proportional Gain, page 214	P8-57	VAR UINT32 rw	0 300 100000000

IDN	Name	Parameter	Object type	Minimum value
			Data type	Factory setting
			Access	Maximum value
P-0-3008.0.58	Velocity Integral Gain, page 214	P8-58	VAR UINT32 rw	0 30000 200000000
P-0-3008.0.59	Velocity Feedforward Ratio	P8-59	VAR UINT16 rw	0 900 1000
P-0-3008.0.60	Velocity Loop Output Filter Mode, page 214	P8-60	VAR UINT16 rw	0 2 3
P-0-3008.0.61	Velocity Loop Output Filter Parameter 1, page 214	P8-61	VAR UINT16 rw	1 500 10000
P-0-3008.0.62	Velocity Loop Output Filter Parameter 2, page 214	P8-62	VAR UINT16 rw	1 500 10000
P-0-3008.0.63	Velocity Filter Mode	P8-63	VAR UINT16 rw	0 1 2
P-0-3008.0.64	Velocity Filter Pole Frequency	P8-64	VAR UINT16 rw	20 440 2000
P-0-3008.0.65	Current Feedforward Low Pass Filter	P8-65	VAR UINT16 rw	10 1000 1000
P-0-3008.0.66	LTN Torque Filter Mode	P8-66	VAR UINT16 rw	0 0 1
P-0-3008.0.67	LTN Torque Filter Bandwidth	P8-67	VAR UINT16 rw	50 1000 2000
P-0-3008.0.68	Current Filter - Notch Filter Mode	P8-68	VAR UINT16 rw	0 0 1
P-0-3008.0.69	Standstill Mode	P8-69	VAR UINT16 rw	0 0 1
P-0-3008.0.70	Standstill Gain	P8-70	VAR UINT16 rw	128 1024 1024

IDN	Name	Parameter	Object type	Minimum value
			Data type	Factory setting
			Access	Maximum value
P-0-3008.0.71	Encoder Filter Mode	P8-71	VAR	0
			INT16	1
			rw	1
P-0-3008.0.99	Adaptive Velocity Reference Value Gain	P8-99	VAR	0
			UINT32	1000
			rw	3000

P9 Object Group

P9 Object Group

Part of this objects list is also available in P9 - DTM data parameters, page 215

IDN	Name	Parameter	Object type	Minimum value
			Data type	Factory setting
			Access	Maximum value
P-0-3009.0.0	Lexium program number	P9-00	VAR	0
			UINT32	-
			ro	4294967295
P-0-3009.0.1	Firmware Version Date	P9-01	VAR	0
			UINT32	-
			ro	4294967295
P-0-3009.0.2	MTP Identification Code	P9-02	VAR	0
			UINT16	-
			ro	65535
P-0-3009.0.3	User-Defined Application Name 1	P9-06	VAR	0
			UINT32	0
			rw	4294967295
P-0-3009.0.7	User-Defined Application Name 2	P9-07	VAR	0
			UINT32	0
			rw	4294967295
P-0-3009.0.8	User-Defined Application Name 3	P9-08	VAR	0
			UINT32	0
			rw	4294967295
P-0-3009.0.9	User-Defined Application Name 4	P9-09	VAR	0
			UINT32	0
			rw	4294967295
P-0-3009.0.10	Modbus Word Order	P9-10	VAR	0
			UINT16	0
			rw	1
P-0-3009.0.11	Serial Number Part 1	P9-11	VAR	0
			UINT32	-
			ro	4294967295

IDN	Name	Parameter	Object type	Minimum value
			Data type	Factory setting
			Access	Maximum value
P-0-3009.0.12	Serial Number Part 2	P9-12	VAR UINT32 ro	0 - 4294967295
P-0-3009.0.13	Serial Number Part 3	P9-13	VAR UINT32 ro	0 - 4294967295
P-0-3009.0.14	Serial Number Part 4	P9-14	VAR UINT32 ro	0 - 4294967295
P-0-3009.0.15	Autotuning Method	P9-15	VAR UINT16 rw	0 0 6
P-0-3009.0.16	Autotuning Motion Profile - Type	P9-16	VAR UINT16 rw	0 0 2
P-0-3009.0.17	Anti-vibration tuning mode.	P9-17	VAR UINT16 rw	0 0 6
P-0-3009.0.18	Autotuning Results - Save/Discard	P9-18	VAR UINT16 rw	0 0 3
P-0-3009.0.19	Autotuning - Elasticity Compensation Filters	P9-19	VAR INT16 rw	0 1 1
P-0-3009.0.20	Autotuning - Direction of Movement	P9-20	VAR INT16 rw	0 0 3
P-0-3009.0.21	Minimum Dwell Time for Detection of Movement Cycle	P9-21	VAR UINT16 rw	100 200 1000
P-0-3009.0.22	Autotuning - Automatic Estimation of Ratio of Load Inertia and Motor Inertia	P9-22	VAR UINT16 rw	0 0 1
P-0-3009.0.23	Defines which values will be used for the position command filters.	P9-23	VAR UINT16 rw	0 0 1
P-0-3009.0.25	Autotuning Motion Profile - Activation	P9-25	VAR UINT16 rw	0 0 1
P-0-3009.0.26	Autotuning - Movement Range in Direction1	P9-26	VAR INT32 rw	-2147483647 0 2147483647

IDN	Name	Parameter	Object type	Minimum value
			Data type	Factory setting
			Access	Maximum value
P-0-3009.0.27	Autotuning - Movement Range in Direction2	P9-27	VAR INT32 rw	-2147483647 0 2147483647
P-0-3009.0.28	Autotuning Active	P9-28	VAR INT16 ro	0 - 1
P-0-3009.0.29	Autotuning - Velocity	P9-29	VAR UINT32 rw	- - -
P-0-3009.0.30	Autotuning - Status	P9-30	VAR UINT32 ro	0 - 65535
P-0-3009.0.31	Autotuning - Acceleration and Deceleration	P9-31	VAR UINT32 rw	6 6 6000 6000 65500 65500
P-0-3009.0.32	Autotune advance mode.	P9-32	VAR UINT16 rw	0 1 2
P-0-3009.0.33	Maximum Autotuning Optimization Value	P9-33	VAR UINT32 ro	0 - 1000
P-0-3009.0.34	Autotuning Progress Bar	P9-34	VAR UINT16 ro	0 0 100
P-0-3009.0.35	Autotuning - Gravity Estimation	P9-35	VAR UINT16 rw	0 0 1
P-0-3009.0.36	Set LTNAFRC in Autotune	P9-36	VAR INT16 rw	0 0 2
P-0-3009.0.37	Autotuning - Last Stored Event	P9-37	VAR UINT32 ro	0 0 65535
P-0-3009.0.38	Mode 2 AT improvment	P9-38	VAR UINT16 ro	0 0 100
P-0-3009.0.39	Cycle Identification status	P9-39	VAR UINT16 ro	0 0 9
P-0-3009.0.40	LTN Autotuning Using Defaults	P9-40	VAR UINT16 rw	0 0 1

P11 Object Group

P11 Vendor-specific Object Group

IDN	Name	Parameter	Object type		
			Data type	Access	
			Minimum value	Factory setting	Maximum value
P-0-3030.0.39	Position	-	VAR INT32 ro	- - -	
P-0-3030.0.12	Target Position in PUU	-	VAR INT32 ro	- - -	
P-0-3011.0.2	Position Deviation in PUU	-	VAR INT32 ro	- - -	
P-0-3011.0.3	Actual Position in Pulses	-	VAR INT32 ro	- - -	
P-0-3011.0.4	Target Position in Pulses	-	VAR INT32 ro	- - -	
P-0-3011.0.5	Position Deviation in Pulses	-	VAR INT32 ro	- - -	
P-0-3011.0.6	Input Frequency	-	VAR INT32 ro	- - -	
P-0-3011.0.7	Actual Velocity in rpm	-	VAR INT32 ro	- - -	
P-0-3011.0.9	Target Velocity in rpm	-	VAR INT32 ro	- - -	
P-0-3011.0.11	Target Torque in Percent of Nominal Current	-	VAR INT32 ro	- - -	
P-0-3011.0.14	DC Bus Voltage	-	VAR INT32 ro	- - -	
P-0-3011.0.15	Ratio of Load Inertia and Motor Inertia	-	VAR INT32 ro	- - -	
P-0-3011.0.16	Drive Temperature - Power Stage	-	VAR INT32 ro	- - -	

IDN	Name	Parameter	Object type	Minimum value
			Data type	Factory setting
			Access	Maximum value
P-0-3011.0.23	Indicate P0-09	-	VAR INT32 ro	- - -
P-0-3011.0.24	Indicate P0-10	-	VAR INT32 ro	- - -
P-0-3011.0.25	Indicate P0-11	-	VAR INT32 ro	- - -
P-0-3011.0.26	Indicate P0-12	-	VAR INT32 ro	- - -
P-0-3011.0.27	Drive Temperature - Controller	-	VAR INT32 ro	- - -
P-0-3011.0.29	Digital Inputs	-	VAR INT32 ro	- - -
P-0-3011.0.40	Digital Outputs	-	VAR INT32 ro	- - -
P-0-3011.0.41	Drive Status	-	VAR INT32 ro	- - -
P-0-3011.0.42	Operating Mode	-	VAR INT32 ro	- - -
P-0-3011.0.49	External Encoder	-	VAR INT32 ro	- - -
P-0-3011.0.50	Target Velocity in rpm	-	VAR INT32 ro	- - -
P-0-3011.0.53	Target Torque	-	VAR INT32 ro	- - -
P-0-3011.0.54	Actual Torque in Percent	-	VAR INT32 ro	- - -
P-0-3011.0.55	Actual Torque in A	-	VAR INT32 ro	- - -

IDN	Name	Parameter	Object type	Minimum value
			Data type	Factory setting
			Access	Maximum value
P-0-3011.0.60	Target Position Raw	-	VAR INT32 ro	- - -
P-0-3011.0.61	Position Deviation Raw in PUU	-	VAR INT32 ro	- - -
P-0-3011.0.62	Target Position Raw in Pulses	-	VAR INT32 ro	- - -
P-0-3011.0.63	Position Deviation Raw in Pulses	-	VAR INT32 ro	- - -
P-0-3011.0.77	Target Velocity	-	VAR INT32 ro	- - -

Device-Specific Object Group

Device-Specific Object Group

Object Group

IDN	Name	Data type	Minimum value
		Access	Factory setting
			Maximum value
P-0-3004.0.1	Save parameter values to the non-volatile memory.	s16 RW	0 NA 11
P-0-3006.0.33	Velocity scaling: Denominator	u32 RW	1 1 2147483647
P-0-3006.0.34	Velocity scaling: Numerator	u32 RW	1 1 2147483647
P-0-3006.0.10	Acceleration of the motion profile for velocity	u32 RW	1 20000 4294967295
P-0-3006.0.11	Deceleration of the motion profile for velocity	u32 RW	1 20000 4294967295

IDN	Name	Data type	Minimum value
		Access	Factory setting Maximum value
P-0-3008.0.1	Physical status of the digital inputs and outputs	u16 RO	0 0 1
P-0-3008.0.17	Setting the digital outputs directly	u32 RW	0 0 15
P-0-3010.0.7	Capture input 2 captured position (one-time)	s32 RO	-2147483648 0 2147483647
P-0-3010.0.2	Capture input 1 configuration	u16 RW	0 0 2
P-0-3010.0.3	Capture input 2 configuration	u16 RW	0 0 2
P-0-3010.0.31	Touch Probe CapEdgeStatus	u16 RW	NA NA NA
P-0-3010.0.4	Capture input 1 start/stop	u16 RW	0 NA 4
P-0-3010.0.5	Capture input 2 start/stop	u16 RW	0 NA 4
P-0-3010.0.10	Capture input 1 encoder source	u16 RW	0 0 1
P-0-3010.0.11	Capture input 2 encoder source	u16 RW	0 0 1
P-0-3010.0.6	Capture input 1 captured position (one-time).	s32 RO	-2147483648 0 2147483647
P-0-3013.0.22	Continuous stall torque of motor	s16 RW	NA NA NA
P-0-3020.0.0	Position Demand Value	s32 RO	NA NA NA
P-0-3030.0.10	Position Actual Internal Value	s32 RO	NA NA NA

IDN	Name	Data type	Minimum value
		Access	Factory setting Maximum value
P-0-3040.0.11	Position at reference point	s32 RW	-2147483648 0 2147483647
P-0-3006.0.5	Min Software Position Limit	s32 RW	-2147483648 -134217727 2147483647
P-0-3006.0.4	Max Software Position Limit	s32 RW	-2147483648 -134217727 2147483647
P-0-3013.0.4	Max Motor Speed	u32 RO	0 0 4294967295
P-0-3020.0.14	Position encoder resolution Encoder Increments	u32 RW	16 2048 10000000
P-0-3020.0.15	Position encoder resolution Motor Revolutions	u32 RO	NA NA NA
P-0-3020.0.16	Feed Constant Feed	u32 RW	0 131072 4294967295
P-0-3020.0.17	Feed Constant Shaft Revolutions	u32 RW	0 1 4294967295
P-0-3027.0.12	Homing Method	u16 RW	1 18 35
P-0-3040.0.4	Fast Homing Speed	u32 RW	10 1000 60000
P-0-3005.0.11	Following Error Time Out	u16 RW	0 0 65535
P-0-3040.0.5	Slow Homing Speed	u32 RW	10 200 60000
P-0-3020.0.21	Homing Acceleration	u32 RW	1 65536000 4294967295
P-0-3020.0.22	Position Offset	s32 RW	-2147483648 0 2147483647

IDN	Name	Data type	Minimum value
		Access	Factory setting Maximum value
P-0-3020.0.23	Velocity Offset	s32 RW	-2147483648 0 2147483647
P-0-3020.0.24	Torque Offset	s16 RW	-32768 0 32767
P-0-3020.0.25	Touch Probe Function	u16 RW	0 0 65535
P-0-3010.0.1	Status of the capture inputs	u16 RW	NA NA NA
P-0-3010.0.37	Capture input 1 captured position at rising edge	s32 RO	NA NA NA
P-0-3010.0.38	Capture input 1 captured position at falling edge	s32 RO	NA NA NA
P-0-3010.0.39	Capture input 2 captured position at rising edge	s32 RO	NA NA NA
P-0-3020.0.3	Position Window	u32 RO	0 0 4294967295
P-0-3010.0.40	Capture input 2 captured position at falling edge	s32 RO	NA NA NA
P-0-3020.0.31	Interpolation Sub Mode Select	s16 RW	0 0 3
P-0-3031.0.12	Max Acceleration	u32 RW	1 436906667 4294967295
P-0-3020.0.33	Max Deceleration	u32 RW	1 436906667 4294967295
P-0-3010.0.43	Capture input 1 event counter at rising edges	u16 RO	NA NA NA
P-0-3010.0.44	Capture input 1 event counter at falling edges	u16 RO	NA NA NA

IDN	Name	Data type	Minimum value
		Access	Factory setting Maximum value
P-0-3010.0.45	Capture input 2 event counter at rising edges	u16 RO	NA NA NA
P-0-3010.0.46	Capture input 2 event counter at falling edges	u16 RO	NA NA NA
P-0-3020.0.38	Position Demand Internal Value	s32 RO	NA NA NA
P-0-3020.0.39	Fieldbus Gear Driving Shaft Scaling	u32 RW	0 1 4294967295
P-0-3020.0.4	Position Window Time	u16 RW	0 1 65535
P-0-3020.0.40	Fieldbus Gear Motor Shaft Scaling	u32 RW	0 1 4294967295
P-0-3020.0.41	Digital Output Physical	u32 RW	NA NA NA
P-0-3020.0.42	Digital Output Mask	u32 RW	NA 4294967295 NA
P-0-3020.0.5	Velocity Demand Value	u32 RO	NA NA NA
P-0-3020.0.6	Torque Demand Value	s16 RO	NA NA NA
P-0-3020.0.7	Motor Rated Current	u32 RO	NA NA NA
P-0-3020.0.8	Motor Rated Torque	u32 RO	NA NA NA
P-0-3020.0.9	DC Link Circuit Voltage	u32 RO	NA NA NA
P-0-3025.0.80	SPD Sercos control (CAP1 and CAP2)	u16 RW	NA NA NA

IDN	Name	Data type	Minimum value
		Access	Factory setting Maximum value
P-0-3025.0.81	SPD Sercos status (CAP1 and CAP2)	u16 RO	NA 0 NA
P-0-3027.0.13	Velocity Command Value Temp	s32 RW	NA 0 NA
P-0-3027.0.16	Torque Command Value Temp	s16 RW	NA 0 NA
P-0-3027.0.4	Active operating mode	s16 RO	NA NA NA
P-0-3028.0.4	Action Status	u16 RO	NA NA NA
P-0-3030.0.18	Position Deviation Monitoring - Threshold Value	s32 RO	-2147483646 NA 2147483647
P-0-3030.0.3	Motor Current	s16 RO	0 NA 32767
P-0-3030.0.32	Velocity Feedback Value 1 Temp	s32 RO	NA 0 NA
P-0-3030.0.36	Torque Feedback Value Temp	s16 RO	NA 0 NA
P-0-3010.0.23	Capture input 1 event counter (Continuous)	u16 RO	- - -
P-0-3010.0.24	Capture input 1 event position (Continuous)	u16 RO	- - -
P-0-3010.0.25	Capture input 2 event counter (Continuous)	u16 RO	- - -
P-0-3010.0.26	Capture input 2 event position (Continuous)	u16 RO	- - -
P-0-3010.0.8	Capture input 1 Event Counter	u16 RO	- - -

IDN	Name	Data type	Minimum value
		Access	Factory setting Maximum value
P-0-3010.0.9	Capture input 2 Event Counter	u16 RO	- - -
P-0-3028.0.35	Current Overload	u16 RO	- - -
P-0-3071.0.2	Fieldbus Communication Status	s16 RO	- - -
P-0-4028.1.35	MICONT - the nominal current of the motor	u16 RO	- - -
P-0-4020.0.7	Home offset	s32 RW	-2147483648 0 2147483647

SERCOS III Hardware Setup

What's in This Chapter

SERCOS III Connector Description (CN4) 324
 Cable Routing Practices 324

SERCOS III Connector Description (CN4)

SERCOS III Dual Port/RJ45 Connector

The following figure shows the SERCOS III dual port/RJ45 connector on the device.

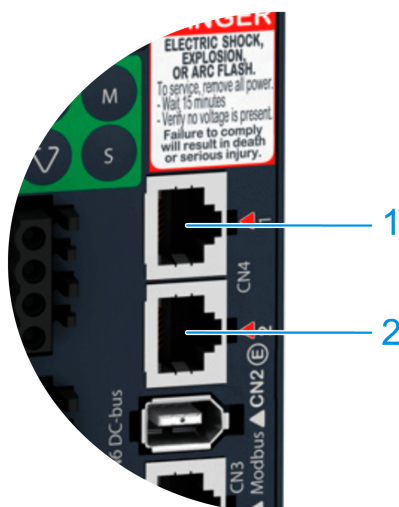

Item	Description
1	(SERCOS III IN X1) RJ45 connector
2	(SERCOS III OUT X2) RJ45 connector

Cable Routing Practices

Installation Topology

The OUT connector of the SERCOS III controller is connected to the IN (X1) connector of the drive.

Each OUT (X2) connector of a drive is connected to the IN (X1) connector of the next drive.

If this wiring rule is not respected, the network topology will not be discovered correctly by the SERCOS III controller.

Example of daisy chain topology with a LMC078 or a M262 Motion controller:

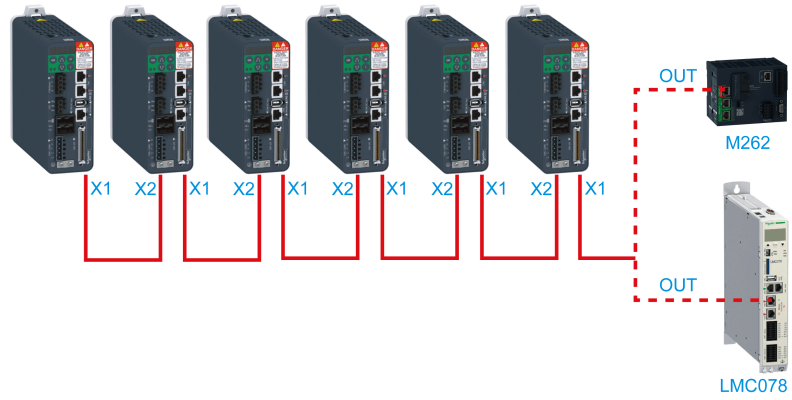

Example of ring topology with a LMC078:

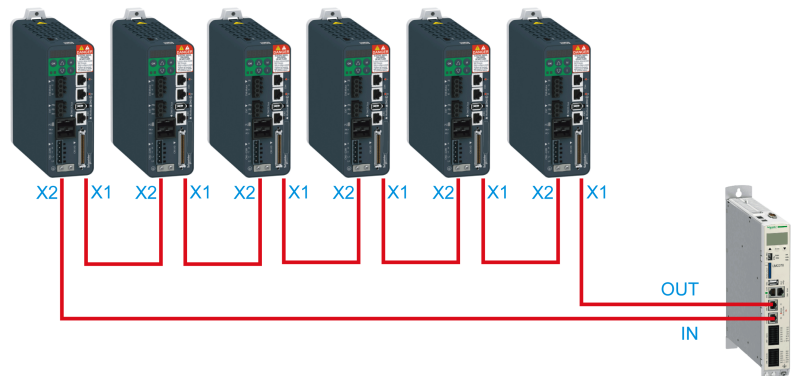

Glossary

A

analog input:

Converts received voltage or current levels into numerical values. You can store and process these values within the logic controller.

analog output:

Converts numerical values within the logic controller and sends out proportional voltage or current levels.

AWG:

(American wire gauge) The standard that specifies wire section sizes in North America.

C

CAN:

(controller area network) A protocol (ISO 11898) for serial bus networks, designed for the interconnection of smart devices (from multiple manufacturers) in smart systems and for real-time industrial applications. Originally developed for use in automobiles, CAN is now used in a variety of industrial automation control environments.

CANopen:

An open industry-standard communication protocol and device profile specification (EN 50325-4).

CCW:

Counter ClockWise

CSA:

(Canadian standards association) The Canadian standard for industrial electronic equipment in hazardous environments.

CW:

ClockWise

D

Degree of Protection:

The degree of protection is a standardized specification for electrical equipment that describes the protection against the ingress of foreign objects and water (for example: IP 20).

DIN:

(Deutsches Institut für Normung) A German institution that sets engineering and dimensional standards.

DOM:

Date of manufacturing: The nameplate of the product shows the date of manufacture in the format DD.MM.YY or in the format DD.MM.YYYY. For example: 31.12.11 corresponds to December 31, 2011; 31.12.2011 corresponds to December 31, 2011

DTM:

(*device type manager*) Classified into 2 categories:

- Device DTMs connect to the field device configuration components.
- CommDTMs connect to the software communication components.

The DTM provides a unified structure for accessing device parameters and configuring, operating, and diagnosing the devices. DTMs can range from a simple graphical user interface for setting device parameters to a highly sophisticated application capable of performing complex real-time calculations for diagnosis and maintenance purposes.

E**EMC:**

Electromagnetic compatibility

Encoder :

Sensor that converts a measured distance or angle into an electrical signal. This signal is evaluated by the drive to determine the actual position of a shaft (rotor) or a driving unit.

F**Factory Settings:**

Settings when the product is shipped.

Fault :

Fault is an operating state. If the monitoring functions detect an error, a transition to this operating state is triggered, depending on the error class. A "Fault Reset" or a power cycle are required to exit this operating state. Prior to this, the cause of the detected error must be removed. Further information can be found in the pertinent standards such as IEC 61800-7, ODVA Common Industrial Protocol (CIP).

Fault Reset:

Function used to exit the operating state Fault. Before the function is used, the cause of the detected error must be removed.

firmware:

Represents the BIOS, data parameters, and programming instructions that constitute the operating system on a controller. The firmware is stored in non-volatile memory within the controller.

flash memory:

A non-volatile memory that can be overwritten. It is stored on a special EEPROM that can be erased and reprogrammed.

H**HMI:**

(*human machine interface*) An operator interface (usually graphical) for human control over industrial equipment.

I**IEC:**

(*international electrotechnical commission*) A non-profit and non-governmental international standards organization that prepares and publishes international standards for electrical, electronic, and related technologies.

I/O:

(input/output)

IT Mains:

Mains in which all active components are isolated from ground or are grounded by a high impedance. IT: isolé terre (French), isolated ground. Opposite: Grounded mains, see TT/TN mains

L**LED:**

(light emitting diode) An indicator that illuminates under a low-level electrical charge.

Limit Switch:

Switches that signal overtravel of the permissible range of travel.

M**Modbus:**

The protocol that allows communications between many devices connected to the same network.

Monitoring Function:

Monitoring functions acquire a value continuously or cyclically (for example, by measuring) in order to check whether it is within permissible limits. Monitoring functions are used for error detection.

ms:

(millisecond)

N**network:**

A system of interconnected devices that share a common data path and protocol for communications.

node:

An addressable device on a communication network.

non-volatile memory:

A memory that can be overwritten. It is stored on a special EEPROM that can be erased and reprogrammed.

P**Parameter :**

Device data and values that can be read and set (to a certain extent) by the user.

PELV:

Protective Extra Low Voltage, low voltage with isolation. For more information: IEC 60364-4-41

PE:

(Protective Earth) A common grounding connection to help avoid the hazard of electric shock by keeping any exposed conductive surface of a device at earth potential. To avoid possible voltage drop, no current is allowed to flow in this conductor (also referred to as *protective ground* in North America or as an equipment grounding conductor in the US national electrical code).

Position Deviation:

The position deviation is the difference between reference position and actual position. The current position deviation consists of the load-dependent position deviation and the dynamic position deviation.

Power Stage :

The power stage controls the motor. The power stage generates current for controlling the motor on the basis of the motion signals from the controller.

PWM:

(pulse width modulation) A fast output that oscillates between off and on in an adjustable duty cycle, producing a rectangular wave form (though you can adjust it to produce a square wave). The PTO is well adapted to simulate or approximate an analog output in that it regulates the voltage of the output over its period making it useful in light dimming or speed control applications, among others.

Q**Quick Stop:**

The quick Stop function can be used for fast deceleration of a movement as a response to a detected error or via a command.

R**RJ45:**

A standard type of 8-pin connector for network cables defined for Ethernet.

rms:

"Root Mean Square" value of a voltage (V_{rms}) or a current (A_{rms})

RPM:

(revolutions per minute)

S**Safety Function:**

Safety functions are defined in the standard IEC 61800-5-2 (for example, Safe Torque Off (STO), Safe Operating Stop (SOS) or Safe Stop 1 (SS1)). If the safety functions are wired properly, they meet the requirements specified in IEC 61800-5-2.

Sercos:

(serial real-time communications system) A digital control bus that interconnects, motion controls, drives, I/Os, sensors, and actuators for numerically controlled machines and systems. It is a standardized and open controller-to-intelligent digital device interface, designed for high-speed serial communication of standardized closed-loop real-time data.

STO:

(Safe Torque Off) The Safety Function STO (IEC 61800-5-2) ("Safe Torque Off") removes power to the motor thereby relieving the torque applied by the motor. There is no monitoring for standstill..

T

TN Mains:

Grounded mains, differ in terms of the ground connection (PE conductor connection). Opposite: Ungrounded mains, see IT mains.

touchprobe input:

Touchprobe inputs are advanced digital inputs. These inputs are used for measuring functions, which accurately detect positions relative to a measure input. Once a touchprobe function has been activated, it runs independently in the system, independent of the IEC program. The IEC program can use parameters to detect the state of the measuring function. This function is supported by hardware and software.

TP:

(touch probe) A position capture that is triggered by a fast input signal (quick sensor). On the rising edge of the touch probe input, the position of an encoder is captured.

For example, this is used for packaging machines to capture the position of a printmark on a film to cut on the same position.

TT Mains:

Grounded mains, differ in terms of the ground connection (PE conductor connection). Opposite: Ungrounded mains, see IT mains.

U

UL:

(underwriters laboratories) A US organization for product testing and safety certification.

Index

A		M	
access channels	223	manual tuning	156
accessories		monitoring functions	90
external braking resistors.....	89	mounting distances;ventilation	96
external mains filters	73	mounting position	125
B		N	
braking resistor		nameplate	27, 40
rating	88	O	
C		online help	143
cable specifications		operating states	224
protected cable installation	84	overvoltage category UL	25
cables	74	P	
category 0 stop	81	P0-00	171
category 1 stop	81	P0-01	171
comfort tuning	150	P0-02	171
commissioning software.....	143	P0-04	171
common DC bus	76	P0-08	171
components and interfaces	39	P0-09	171
control cabinet	96	P0-10	172
D		P0-11	172
DC bus	76	P0-12	172
degree of protection.....	29	P0-13	172
dimensions		P0-17	172
drive	30	P0-18	172
disposal.....	276–277	P0-19	172
drive:mounting	97	P0-20	172
E		P0-21	173
easy tuning	149	P0-25	173
Electrical Installation Drive	98	P0-26	173
electromagnetic compatibility (EMC).....	71	P0-27	173
EMC.....	71	P0-28	173
improvement of EMC.....	73	P0-29	173
environmental conditions		P0-30	173
drive	28	P0-31	173
motor	43	P0-32	174
equipotential bonding conductors	72, 74	P0-35	174
F		P0-36	174
Fault Reset	225	P0-37	174
function		P0-38	174
safety function	81	P0-39	175
functional safety	78	P0-40	175
fuses UL	25	P0-41	175
H		P0-42	175
hazard and risk analysis.....	77	P0-46	176
I		P0-47	176
improvement of EMC.....	73	P1-01	177
installation site and connection	29	P1-02	177
		P1-03	178
		P1-06	178
		P1-07	178
		P1-09	178
		P1-10	178
		P1-11	178
		P1-12	178
		P1-13	179
		P1-14	179
		P1-15	179

P1-16	179	P2-29	190
P1-17	179	P2-30	190
P1-19	179	P2-31	190
P1-20	179	P2-32	190
P1-21	180	P2-34	190
P1-22	180	P2-35	190
P1-23	180	P2-50	191
P1-24	180	P2-65	191
P1-25	180	P2-66	192
P1-26	180	P2-68	192
P1-27	180	P2-71	192
P1-28	180	P2-72	193
P1-29	181	P2-73	193
P1-30	181	P3-00	193
P1-32	181	P3-01	193
P1-34	181	P3-02	193
P1-35	181	P3-03	193
P1-37	182	P3-04	194
P1-38	182	P3-05	194
P1-39	182	P3-06	194
P1-42	182	P3-07	194
P1-44	182	P3-08	194
P1-45	182	P3-30	194
P1-46	182	P3-31	195
P1-52	182	P3-32	195
P1-53	182	P3-33	195
P1-54	183	P4-00	196
P1-55	183	P4-01	196
P1-57	183	P4-02	196
P1-58	183	P4-03	196
P1-59	183	P4-04	196
P1-60	183	P4-05	196
P1-61	183	P4-06	196
P1-62	183	P4-07	197
P1-63	184	P4-08	197
P1-64	184	P4-09	197
P1-66	184	P4-10	197
P1-67	184	P4-24	198
P1-68	184	P4-25	198
P1-69	184	P4-26	198
P1-71	185	P4-27	198
P1-72	185	P4-28	199
P1-78	185	P4-29	199
P1-79	185	P5-00	199
P1-80	185	P5-04	199
P1-81	185	P5-05	200
P1-82	185	P5-06	200
P1-84	185	P5-08	200
P1-85	186	P5-09	200
P1-87	186	P5-11	200
P2-01	186	P5-12	200
P2-05	186	P5-13	200
P2-08	186	P5-14	201
P2-09	187	P5-15	201
P2-10	187	P5-16	201
P2-11	187	P5-18	201
P2-12	187	P5-21	201
P2-13	187	P5-22	201
P2-14	188	P5-23	201
P2-15	188	P5-24	202
P2-16	188	P5-25	202
P2-17	188	P5-26	202
P2-18	188	P5-35	202
P2-19	188	P5-36	202
P2-20	189	P5-37	202
P2-21	189	P5-38	202
P2-23	189	P5-39	202
P2-24	189	P5-56	203
P2-27	189	P5-57	203

P5-58	203	P8-72	214
P5-59	203	P8-99	214
P5-76	203	P9-00	215
P5-77	203	P9-01	215
P5-78	204	P9-02	215
P5-79	204	P9-06	215
P5-80	204	P9-07	215
P5-81	204	P9-08	216
P5-82	204	P9-09	216
P8-00	205	P9-10	216
P8-01	205	P9-11	216
P8-02	205	P9-12	216
P8-03	205	P9-13	216
P8-04	205	P9-14	216
P8-05	205	P9-15	216
P8-06	205	P9-16	217
P8-07	205	P9-17	217
P8-08	206	P9-18	217
P8-09	206	P9-19	217
P8-10	206	P9-20	217
P8-11	206	P9-21	217
P8-12	206	P9-22	217
P8-13	206	P9-23	217
P8-14	206	P9-25	218
P8-15	206	P9-26	218
P8-16	207	P9-27	218
P8-17	207	P9-28	218
P8-18	207	P9-29	218
P8-19	207	P9-30	218–219
P8-20	207	P9-31	220
P8-21	207	P9-32	220
P8-32	207	P9-33	220
P8-33	207	P9-34	220
P8-34	208	P9-35	221
P8-35	208	P9-36	221
P8-36	208	P9-37	221
P8-37	208	P9-38	221
P8-38	208	P9-39	221
P8-39	208	P9-40	221
P8-40	209	parallel connection DC bus	76
P8-41	209	permissible product combinations	33
P8-42	209	pollution degree	29
P8-43	209	protected cable installation	84
P8-44	209	PWM frequency power stage	33
P8-45	209		
P8-46	209		
P8-47	210		
P8-48	210		
P8-49	210		
P8-51	210		
P8-53	211		
P8-54	211		
P8-55	211		
P8-56	211		
P8-57	211		
P8-58	211		
P8-59	211		
P8-60	212		
P8-61	212		
P8-62	212		
P8-63	212		
P8-64	212		
P8-65	212		
P8-66	213		
P8-67	213		
P8-68	213		
P8-69	213		
P8-70	213		
P8-71	213–214		
		Q	
		Qualification of Personnel	9
		R	
		rating of braking resistor	88
		Representation of the Parameters	170
		requirements	
		safety function	82
		resetting error message	225
		S	
		safe torque off	76
		safety function	
		function	81
		requirements	82
		safety function STO	76
		scope of supply	94
		shipping	276
		state diagram	224
		STO	76

function	81
requirements	82
storage	276

T

tuning the control loops	149
type code	28, 41
drive	28
motor	41
type of cooling	33

U

UL	
conditions for wiring	25
fuses	25
overvoltage category	25

W

weights	
drive	31
wiring UL	25

Schneider Electric
35 rue Joseph Monier
92500 Rueil Malmaison
France

+ 33 (0) 1 41 29 70 00

www.se.com

As standards, specifications, and design change from time to time, please ask for confirmation of the information given in this publication.

© 2025 Schneider Electric. All rights reserved.

EIO0000004027.02