

# Modicon MCM

## Modular Safety Controller

### Hardware Guide

EIO0000004000.03  
01/2026



# Legal Information

The information provided in this document contains general descriptions, technical characteristics and/or recommendations related to products/solutions.

This document is not intended as a substitute for a detailed study or operational and site-specific development or schematic plan. It is not to be used for determining suitability or reliability of the products/solutions for specific user applications. It is the duty of any such user to perform or have any professional expert of its choice (integrator, specifier or the like) perform the appropriate and comprehensive risk analysis, evaluation and testing of the products/solutions with respect to the relevant specific application or use thereof.

The Schneider Electric brand and any trademarks of Schneider Electric SE and its subsidiaries referred to in this document are the property of Schneider Electric SE or its subsidiaries. All other brands may be trademarks of their respective owner.

This document and its content are protected under applicable copyright laws and provided for informative use only. No part of this document may be reproduced or transmitted in any form or by any means (electronic, mechanical, photocopying, recording, or otherwise), for any purpose, without the prior written permission of Schneider Electric.

Schneider Electric does not grant any right or license for commercial use of the document or its content, except for a non-exclusive and personal license to consult it on an "as is" basis.

Schneider Electric reserves the right to make changes or updates with respect to or in the content of this document or the format thereof, at any time without notice.

**To the extent permitted by applicable law, no responsibility or liability is assumed by Schneider Electric and its subsidiaries for any errors or omissions in the informational content of this document, as well as any non-intended use or misuse of the content thereof.**

# Table of Contents

Safety Information .....	6
Before You Begin .....	6
Start-up and Test .....	7
Operation and Adjustments .....	8
About the Document .....	9
<b>Common Hardware Information .....</b>	<b>17</b>
General Information on the Modular Safety Controller .....	18
Key Safety-Related Values of the Modular Safety Controller .....	18
Modular Safety Controller System .....	19
Scope of Delivery .....	22
Technical Data .....	24
General System Characteristics .....	24
Mechanical Dimensions .....	26
Electrical Requirements .....	28
Wiring Best Practices .....	28
Terminal Blocks .....	33
<b>Component-Specific Hardware Information .....</b>	<b>35</b>
Technical Features .....	36
XPSMCMCP0802(G) Modular Safety Controller .....	36
Controller and Functional Description .....	36
Connector Designations and Sample Wiring Diagrams .....	39
LED Indicators .....	41
Controller Characteristics .....	42
XPSMCMC10804(G) Modular Safety Controller .....	44
Controller and Functional Description .....	44
Connector Designations and Sample Wiring Diagrams .....	46
LED Indicators .....	51
Controller Characteristics .....	53
XPSMCMC10804E(G) Modular Safety Controller with	
Communication Embedded .....	54
Controller and Functional Description .....	54
Connector Designations, Terminals and Dimensions .....	58
Embedded Communication Interface .....	62
LED Indicators .....	62
Controller Characteristics .....	66
XPSMCMCMAI0200(G) and XPSMCMCMAI0400(G) Analog Input	
Expansion Modules .....	67
Module and Functional Description .....	67
Connector Designations and Sample Wiring Diagrams .....	69
LED Indicators .....	73
Module Characteristics .....	75
XPSMCMCMAI0800(G) and XPSMCMCMAI1600(G) Input Expansion	
Modules .....	77
Module and Functional Description .....	77
Connector Designations and Sample Wiring Diagram .....	77
LED Indicators .....	79
Module Characteristics .....	80
XPSMCMCMAI1200MT(G) Input Expansion Module .....	81

Module and Functional Description .....	81
Connector Designations and Sample Wiring Diagram .....	81
LED Indicators .....	83
Module Characteristics .....	84
XPSMCMDO0002(G) and XPSMCMDO0004(G) Output Expansion	
Modules .....	85
Module and Functional Description .....	85
Connector Designations and Sample Wiring Diagram .....	85
LED Indicators .....	89
Module Characteristics .....	91
XPSMCMDO00042A(G) Output Expansion Module.....	92
Module and Functional Description .....	92
Connector Designations and Sample Wiring Diagrams.....	93
LED Indicators .....	97
Module Characteristics .....	99
XPSMCMDO0004S(G) Output Expansion Module.....	100
Module and Functional Description .....	100
Connector Designations and Sample Wiring Diagrams.....	101
LED Indicators .....	104
Module Characteristics .....	105
XPSMCMDO0008C1(G) Output Expansion Module .....	107
Module and Functional Description .....	107
Connector Designations and Sample Wiring Diagrams.....	107
LED Indicators .....	109
Module Characteristics .....	110
XPSMCMDO0016C1(G) Output Expansion Module .....	111
Module and Functional Description .....	111
Connector Designations and Sample Wiring Diagrams.....	112
LED Indicators .....	114
Module Characteristics .....	115
XPSMCMER00••(G) Output Expansion Modules.....	116
Module and Functional Description .....	116
Connector Designations, Sample Wiring Diagram and	
Dimensions .....	117
LED Indicators .....	122
Module Characteristics .....	122
XPSMCMRO0004DA(G) and XPSMCMRO0004(G) Output	
Expansion Modules.....	124
Module and Functional Description .....	124
Connector Designations and Sample Wiring Diagrams.....	125
LED Indicators .....	127
Module Characteristics .....	128
XPSMCMMX0802(G) Input/Output Expansion Module .....	131
Module and Functional Description .....	131
Connector Designations and Sample Wiring Diagrams.....	132
LED Indicators .....	134
Module Characteristics .....	135
XPSMCMMX0804(G) Input/Output Expansion Module .....	136
Module and Functional Description .....	136
Connector Designations and Sample Wiring Diagrams.....	137
LED Indicators .....	141

---

Module Characteristics .....	142
XPSMCMEN•••(G) Speed Monitoring Expansion Modules .....	144
Modules and Functional Description .....	144
Connector Designations .....	144
LED Indicators .....	146
Module Characteristics .....	147
XPSMCMCO0000S1(G) and XPSMCMCO0000S2(G)	
Communication Expansion Modules.....	149
Communication Expansion Modules .....	149
Connector Designations and Cable .....	150
LED Indicators .....	151
Module Characteristics .....	152
Accessories .....	153
USB/Mini B USB or USB/USB-C Configuration Cable .....	153
Configuration Memory Card.....	153
Backplane Expansion Connector .....	155
RS485 Cable.....	156
Encoder Splitter Cables for PacDrive M .....	157
Encoder Splitter Cables for Lexium 32, Lexium 52 and Lexium 62.....	158
Covers for Backplane Connectors .....	161
Encoder Modules RJ45 support .....	161
Index .....	163

# Safety Information

## Important Information

Read these instructions carefully, and look at the equipment to become familiar with the device before trying to install, operate, service, or maintain it. The following special messages may appear throughout this documentation or on the equipment to warn of potential hazards or to call attention to information that clarifies or simplifies a procedure.



The addition of this symbol to a “Danger” or “Warning” safety label indicates that an electrical hazard exists which will result in personal injury if the instructions are not followed.



This is the safety alert symbol. It is used to alert you to potential personal injury hazards. Obey all safety messages that follow this symbol to avoid possible injury or death.

### **DANGER**

**DANGER** indicates a hazardous situation which, if not avoided, **will result in** death or serious injury.

### **WARNING**

**WARNING** indicates a hazardous situation which, if not avoided, **could result in** death or serious injury.

### **CAUTION**

**CAUTION** indicates a hazardous situation which, if not avoided, **could result in** minor or moderate injury.

### **NOTICE**

**NOTICE** is used to address practices not related to physical injury.

## Please Note

Electrical equipment should be installed, operated, serviced, and maintained only by qualified personnel. No responsibility is assumed by Schneider Electric for any consequences arising out of the use of this material.

A qualified person is one who has skills and knowledge related to the construction and operation of electrical equipment and its installation, and has received safety training to recognize and avoid the hazards involved.

## Before You Begin

Do not use this product on machinery lacking effective point-of-operation guarding. Lack of effective point-of-operation guarding on a machine can result in serious injury to the operator of that machine.

<b>▲ WARNING</b>
<p><b>UNGUARDED EQUIPMENT</b></p> <ul style="list-style-type: none"> <li>• Do not use this software and related automation equipment on equipment which does not have point-of-operation protection.</li> <li>• Do not reach into machinery during operation.</li> </ul> <p><b>Failure to follow these instructions can result in death, serious injury, or equipment damage.</b></p>

This automation equipment and related software is used to control a variety of industrial processes. The type or model of automation equipment suitable for each application will vary depending on factors such as the control function required, degree of protection required, production methods, unusual conditions, government regulations, etc. In some applications, more than one processor may be required, as when backup redundancy is needed.

Only you, the user, machine builder or system integrator can be aware of all the conditions and factors present during setup, operation, and maintenance of the machine and, therefore, can determine the automation equipment and the related safeties and interlocks which can be properly used. When selecting automation and control equipment and related software for a particular application, you should refer to the applicable local and national standards and regulations. The National Safety Council's Accident Prevention Manual (nationally recognized in the United States of America) also provides much useful information.

In some applications, such as packaging machinery, additional operator protection such as point-of-operation guarding must be provided. This is necessary if the operator's hands and other parts of the body are free to enter the pinch points or other hazardous areas and serious injury can occur. Software products alone cannot protect an operator from injury. For this reason the software cannot be substituted for or take the place of point-of-operation protection.

Ensure that appropriate safeties and mechanical/electrical interlocks related to point-of-operation protection have been installed and are operational before placing the equipment into service. All interlocks and safeties related to point-of-operation protection must be coordinated with the related automation equipment and software programming.

**NOTE:** Coordination of safeties and mechanical/electrical interlocks for point-of-operation protection is outside the scope of the Function Block Library, System User Guide, or other implementation referenced in this documentation.

## Start-up and Test

Before using electrical control and automation equipment for regular operation after installation, the system should be given a start-up test by qualified personnel to verify correct operation of the equipment. It is important that arrangements for such a check are made and that enough time is allowed to perform complete and satisfactory testing.

<b>▲ WARNING</b>
<p><b>EQUIPMENT OPERATION HAZARD</b></p> <ul style="list-style-type: none"> <li>• Verify that all installation and set up procedures have been completed.</li> <li>• Before operational tests are performed, remove all blocks or other temporary holding means used for shipment from all component devices.</li> <li>• Remove tools, meters, and debris from equipment.</li> </ul> <p><b>Failure to follow these instructions can result in death, serious injury, or equipment damage.</b></p>

Follow all start-up tests recommended in the equipment documentation. Store all equipment documentation for future references.

**Software testing must be done in both simulated and real environments.**

Verify that the completed system is free from all short circuits and temporary grounds that are not installed according to local regulations (according to the National Electrical Code in the U.S.A, for instance). If high-potential voltage testing is necessary, follow recommendations in equipment documentation to prevent accidental equipment damage.

Before energizing equipment:

- Remove tools, meters, and debris from equipment.
- Close the equipment enclosure door.
- Remove all temporary grounds from incoming power lines.
- Perform all start-up tests recommended by the manufacturer.

## Operation and Adjustments

The following precautions are from the NEMA Standards Publication ICS 7.1-1995:

(In case of divergence or contradiction between any translation and the English original, the original text in the English language will prevail.)

- Regardless of the care exercised in the design and manufacture of equipment or in the selection and ratings of components, there are hazards that can be encountered if such equipment is improperly operated.
- It is sometimes possible to misadjust the equipment and thus produce unsatisfactory or unsafe operation. Always use the manufacturer's instructions as a guide for functional adjustments. Personnel who have access to these adjustments should be familiar with the equipment manufacturer's instructions and the machinery used with the electrical equipment.
- Only those operational adjustments required by the operator should be accessible to the operator. Access to other controls should be restricted to prevent unauthorized changes in operating characteristics.

# About the Document

## Document Scope

The present document describes how to use the XPSMCM• Modular Safety Controller system.

The XPSMCM• Modular Safety Controller system consists of a controller unit XPSMCMCP0802(G), XPSMCMC10804(G) or XPSMCMC10804E(G), which can be configured using the SoSafe Configurable software. Expansion input and output modules can be connected to the Modular Safety Controller.

## Validity Note

This document has been updated for the release of SoSafe Configurable V1.9.2.

The characteristics of the products described in this document are intended to match the characteristics that are available on [www.se.com](http://www.se.com). As part of our corporate strategy for constant improvement, we may revise the content over time to enhance clarity and accuracy. If you see a difference between the characteristics in this document and the characteristics on [www.se.com](http://www.se.com), consider [www.se.com](http://www.se.com) to contain the latest information.

## Product Related Information

The XPSMCM• can reach a maximum Safety Integrity Level (SIL) 3 as per IEC 61508, a maximum Safety Integrity Level Claim Limit (SILcl) 3 as per IEC 62061, and a maximum Performance Level (PL) e, category 4, as per ISO 13849-1. However, the definitive SIL and PL of the application depends on a number of safety-related components, their parameters, and the connections that are made, as per the risk analysis.

For details and exceptions, refer to [Modular Safety Controller Key Safety Values](#).

The module must be configured in accordance with the application-specific risk analysis and all the applicable standards.

Ensure to conform to any safety information, different electrical requirements, and normative standards that would apply to your adaptation.

### **DANGER**

#### **HAZARD OF ELECTRIC SHOCK, EXPLOSION, OR ARC FLASH**

- Disconnect all power from all equipment including connected devices prior to removing any covers or doors, or installing or removing any accessories, hardware, cables, or wires except under the specific conditions specified in the appropriate hardware guide for this equipment.
- Always use a properly rated voltage sensing device to confirm the power is off where and when indicated.
- Replace and secure all covers, accessories, hardware, cables, and wires and confirm that a proper ground connection exists before applying power to this equipment.
- Use only the specified voltage when operating this equipment and any associated equipment.

**Failure to follow these instructions will result in death or serious injury.**

**⚠ DANGER****HAZARD OF ELECTRIC SHOCK, EXPLOSION OR ARC FLASH**

- Do not use the equipment described herein to supply external equipment.
- Do not make contact with terminals until the power has been confirmed removed.
- Follow all electrical safety regulations and standards (for example, lockout/tag-out, phase grounding, barriers) to reduce the possibility of contact with hazardous voltages in the work area.
- Complete thorough hardware tests and system commissioning to verify that line voltages are not present on the control circuits before using your hardware operationally.

**Failure to follow these instructions will result in death or serious injury.**

**⚠ DANGER****LOSS OF DESIGNATED SAFETY FUNCTION**

- Install the equipment in an enclosure with a degree of protection of at least IP 54.
- Use a Protective Extra Low Voltage (PELV) power supply to isolate the equipment from line voltage.
- Do not directly connect the equipment to line voltage.

**Failure to follow these instructions will result in death or serious injury.**

**⚠ DANGER****POTENTIAL FOR EXPLOSION**

Install and use the equipment in non-hazardous locations only.

**Failure to follow these instructions will result in death or serious injury.**

**⚠ WARNING****INSUFFICIENT SAFETY-RELATED FUNCTIONS**

- Perform a risk assessment as per ISO 12100 and/or other equivalent assessment and appropriately consider all applicable regulations and standards that apply to your machine/process before using this software.
- In your risk assessment, determine all requirements regarding the Safety Integrity Level (SIL), the Performance Level (PL), and any other safety-related requirements and capabilities applicable to your machine/process.

**Failure to follow these instructions can result in death, serious injury, or equipment damage.**

## ▲ WARNING

### UNAUTHENTICATED ACCESS AND SUBSEQUENT UNAUTHORIZED MACHINE OPERATION

- Evaluate whether your environment or your machines are connected to your critical infrastructure and, if so, take appropriate steps in terms of prevention, based on Defense-in-Depth, before connecting the automation system to any network.
- Limit the number of devices connected to a network to the minimum necessary.
- Isolate your industrial network from other networks inside your company.
- Protect any network against unintended access by using firewalls, VPN, or other, proven security measures.
- Monitor activities within your systems.
- Prevent subject devices from direct access or direct link by unauthorized parties or unauthenticated actions.
- Prepare a recovery plan including backup of your system and process information.

**Failure to follow these instructions can result in death, serious injury, or equipment damage.**

For more information on organizational measures and rules covering access to infrastructures, refer to ISO/IEC 27000 series, Common Criteria for Information Technology Security Evaluation, ISO/IEC 15408, IEC 62351, ISA/IEC 62443, NIST Cybersecurity Framework, Information Security Forum - Standard of Good Practice for Information Security and refer to *Cybersecurity Guidelines for EcoStruxure Machine Expert, Modicon and PacDrive Controllers and Associated Equipment*.

## ▲ WARNING

### LOSS OF CONTROL

- Perform a Failure Mode and Effects Analysis (FMEA), or equivalent risk analysis, of your application, and apply preventive and detective controls before implementation.
- Provide a fallback state for undesired control events or sequences.
- Provide separate or redundant control paths wherever required.
- Supply appropriate parameters, particularly for limits.
- Review the implications of transmission delays and take actions to mitigate them.
- Review the implications of communication link interruptions and take actions to mitigate them.
- Provide independent paths for control functions (for example, emergency stop, over-limit conditions, and error conditions) according to your risk assessment, and applicable codes and regulations.
- Apply local accident prevention and safety regulations and guidelines.<sup>1</sup>
- Test each implementation of a system for proper operation before placing it into service.

**Failure to follow these instructions can result in death, serious injury, or equipment damage.**

<sup>1</sup> For additional information, refer to NEMA ICS 1.1 (latest edition), *Safety Guidelines for the Application, Installation, and Maintenance of Solid State Control* and to NEMA ICS 7.1 (latest edition), *Safety Standards for Construction and Guide for Selection, Installation and Operation of Adjustable-Speed Drive Systems* or their equivalent governing your particular location.

**⚠ WARNING****UNINTENDED EQUIPMENT OPERATION**

- Only use software approved by Schneider Electric for use with this equipment.
- Update your application program every time you change the physical hardware configuration.

**Failure to follow these instructions can result in death, serious injury, or equipment damage.**

The observation of operating limits and duty cycles is of particular importance for equipment designed to perform a safety-related function. If this module has been subjected to electrical, mechanical, or environmental conditions beyond its stated limits, do not use it.

**⚠ WARNING****UNINTENDED EQUIPMENT OPERATION**

- Do not exceed any of the rated operating limits for the equipment specified in the present document.
- Immediately cease using and replace any equipment that has or might have been subjected to conditions beyond its rated operating limits.

**Failure to follow these instructions can result in death, serious injury, or equipment damage.**

There are no user-serviceable parts in this equipment. For reasons of safety and compliance, only the manufacturer should perform repairs to this equipment.

**⚠ WARNING****LOSS OF SAFETY-RELATED FUNCTION**

Do not attempt to repair or alter this equipment.

**Failure to follow these instructions can result in death, serious injury, or equipment damage.**

## General Cybersecurity Information

In recent years, the growing number of networked machines and production plants has seen a corresponding increase in the potential for cyber threats, such as unauthorized access, data breaches, and operational disruptions. You must, therefore, consider all possible cybersecurity measures to help protect assets and systems against such threats.

To help keep your Schneider Electric products secure and protected, it is in your best interest to implement the cybersecurity best practices as described in the Cybersecurity Best Practices document.

Schneider Electric provides additional information and assistance:

- [Subscribe to the Schneider Electric security newsletter.](#)
- [Visit the Cybersecurity Support Portal web page to:](#)
  - [Find Security Notifications.](#)
  - [Report vulnerabilities and incidents.](#)
- [Visit the Schneider Electric Cybersecurity and Data Protection Posture web page to:](#)
  - [Access the cybersecurity posture.](#)
  - [Learn more about cybersecurity in the cybersecurity academy.](#)
  - [Explore the cybersecurity services from Schneider Electric.](#)

## Product Related Cybersecurity Information

Refer to Cybersecurity Guidelines for EcoStruxure Machine Expert, Modicon and PacDrive Controllers and Associated Equipment User Guide.

## Environmental Data

For product compliance and environmental information, refer to the Schneider Electric Environmental Data Program.

## Available Languages of the Document

The document is available in these languages:

- English (EIO0000004000)
- French (EIO0000004001)
- German (EIO0000004002)
- Italian (EIO0000004003)
- Spanish (EIO0000004004)
- Chinese (EIO0000004005)
- Portuguese (EIO0000004006)

## Related Documents

Document title	Reference
Cybersecurity Best Practices	CS-Best-Practices-2019-340
Cybersecurity Guidelines for EcoStruxure Machine Expert, Modicon and PacDrive Controllers and Associated Equipment User Guide	EIO0000004242
Modular Safety Controller - Library and Programming Guide	EIO0000004007 (ENG); EIO0000004008 (FRE); EIO0000004009 (GER); EIO0000004010 (ITA); EIO0000004011 (SPA); EIO0000004012 (CHS) EIO0000004013 (POR)
Modular Safety Controller - Communication Guide	EIO0000004014 (ENG); EIO0000004015 (FRE); EIO0000004016 (GER); EIO0000004017 (ITA); EIO0000004018 (SPA); EIO0000004019 (CHS) EIO0000004020 (POR)

You can download these technical publications and other technical information from our website at [www.se.com/ww/en/download/](http://www.se.com/ww/en/download/).

## Information on Non-Inclusive or Insensitive Terminology

As a responsible, inclusive company, Schneider Electric is constantly updating its communications and products that contain non-inclusive or insensitive terminology. However, despite these efforts, our content may still contain terms that are deemed inappropriate by some customers.

## Terminology Derived from Standards

The technical terms, terminology, symbols and the corresponding descriptions in the information contained herein, or that appear in or on the products themselves, are generally derived from the terms or definitions of international standards.

In the area of functional safety systems, drives and general automation, this may include, but is not limited to, terms such as *safety*, *safety function*, *safe state*, *fault*, *fault reset*, *malfunction*, *failure*, *error*, *error message*, *dangerous*, etc.

Among others, these standards include:

Standard	Description
IEC 61131-2:2007	Programmable controllers, part 2: Equipment requirements and tests.
ISO 13849-1:2023	Safety of machinery: Safety related parts of control systems. General principles for design.
EN 61496-1:2020	Safety of machinery: Electro-sensitive protective equipment. Part 1: General requirements and tests.

Standard	Description
ISO 12100:2010	Safety of machinery - General principles for design - Risk assessment and risk reduction
EN 60204-1:2006	Safety of machinery - Electrical equipment of machines - Part 1: General requirements
ISO 14119:2013	Safety of machinery - Interlocking devices associated with guards - Principles for design and selection
ISO 13850:2015	Safety of machinery - Emergency stop - Principles for design
IEC 62061:2021	Safety of machinery - Functional safety of safety-related electrical, electronic, and electronic programmable control systems
IEC 61508-1:2010	Functional safety of electrical/electronic/programmable electronic safety-related systems: General requirements.
IEC 61508-2:2010	Functional safety of electrical/electronic/programmable electronic safety-related systems: Requirements for electrical/electronic/programmable electronic safety-related systems.
IEC 61508-3:2010	Functional safety of electrical/electronic/programmable electronic safety-related systems: Software requirements.
IEC 61784-3:2021	Industrial communication networks - Profiles - Part 3: Functional safety fieldbuses - General rules and profile definitions.
2006/42/EC	Machinery Directive
2014/30/EU	Electromagnetic Compatibility Directive
2014/35/EU	Low Voltage Directive

In addition, terms used in the present document may tangentially be used as they are derived from other standards such as:

Standard	Description
IEC 60034 series	Rotating electrical machines
IEC 61800 series	Adjustable speed electrical power drive systems
IEC 61158 series	Digital data communications for measurement and control – Fieldbus for use in industrial control systems

Finally, the term *zone of operation* may be used in conjunction with the description of specific hazards, and is defined as it is for a *hazard zone* or *danger zone* in the *Machinery Directive (2006/42/EC)* and *ISO 12100:2010*.

**NOTE:** The aforementioned standards may or may not apply to the specific products cited in the present documentation. For more information concerning the individual standards applicable to the products described herein, see the characteristics tables for those product references.

## Standards Relating to the Modular Safety Controller

The following list provides an overview of the standards that relate to the Modular Safety Controller:

Standard	Description
ISO 13849-1:2023	Safety of machinery - Safety-related parts of control systems - Part 1: General principles for design
ISO 13855:2010	Safety of machinery - Positioning of safeguards with respect to the approach speeds of parts of the human body
IEC 61131-2:2007	Industrial-process measurement and control - Programmable controllers – Part 2: Equipment requirements and tests
EN 61496-1:2013	Safety of machinery - Electro-sensitive protective equipment - Part 1: General requirements and tests

Standard	Description
IEC 61508-1:2010	Functional safety of electrical/electronic/programmable electronic safety-related systems - Part 1: General requirements
IEC 61508-2:2010	Functional safety of electrical/electronic/programmable electronic safety-related systems - Part 2: Requirements for electrical/electronic/programmable electronic safety-related systems
IEC 61508-3:2010	Functional safety of electrical/electronic/programmable electronic safety-related systems - Part 3: Software requirements
IEC 61508-4:2010	Functional safety of electrical/electronic/programmable electronic safety-related systems- Part 4: Definitions and abbreviations
IEC 61800-5-2:2016	Adjustable speed electrical power drive systems - Part 5-2: Safety requirements – Functional
2011/65/EU	Restriction of the use of certain hazardous substances in Electrical and Electronic Equipment

The list of standards relating to the modular safety controller is not intended to be exhaustive relative to your specific application. Further, there may be additional functional safety standards that may apply to your particular application. Consult the User Guides of the Modular Safety Controller and visit the Schneider Electric website at [www.se.com](http://www.se.com) for product certifications which detail compliance with specific standards, regulations, and directives.

## Dual Dimensions

Dimensions are indicated in metric system and U.S. customary units system. The U.S. dimensions are given in parentheses, for example 8.4 mm (0.33 in).

**NOTE:** The given values in parentheses are rounded and for reference only.

---

# Common Hardware Information

## What's in This Part

General Information on the Modular Safety Controller .....	18
Technical Data .....	24
Electrical Requirements .....	28

# General Information on the Modular Safety Controller

## What's in This Chapter

Key Safety-Related Values of the Modular Safety Controller ..... 18  
 Modular Safety Controller System ..... 19  
 Scope of Delivery ..... 22

## Key Safety-Related Values of the Modular Safety Controller

Key safety values	Value	Standard
Probability of a dangerous failure per hour (PFHd)	Refer to module-specific characteristics.	IEC 61508
Safety Integrity Level (SIL)	3	
Hardware Fault Tolerance (HFT)	1 (type B)	
Defined "Safe state" <sup>(1)</sup>	All outputs off	
Safety Integrity Level claim limit (SILcl)	3 <sup>(2)</sup>	IEC 62061
Type	4	EN 61496-1
Performance Level (PL) <sup>(3)</sup>	e <sup>(4)</sup>	EN ISO 13849-1
Diagnostic Coverage <sub>avg</sub>	High	
Mean Time to Dangerous Failure (MTTFd)	125 years with Category 4 architecture, otherwise 100 years <sup>(5)</sup>	
Category <sup>(3)</sup>	4	
Maximum service life	20 years	
<p><b>(1)</b> The Modular Safety Controller and expansion modules are in the defined safe state when their safety-related outputs are deactivated. To exit the defined safe state condition, a combination of hardware inputs is required.</p> <p><b>(2)</b> For the references XPSMCMDO0008C1(G) and XPSMCMDO0016C1(G) modules, the SILcl is 1.</p> <p><b>(3)</b> The EN ISO 13849-1 performance level (PL) and safety category (Cat) of the overall system depend on multiple factors, including the selected modules, the wiring practices, the physical environment, and the application.</p> <p><b>(4)</b> For the references XPSMCMDO0008C1(G) and XPSMCMDO0016C1(G) modules, the Performance Level (PL) is c.</p> <p><b>(5)</b> If expansion modules are added to the configuration, the PFHd and MTTFd of the overall system is affected, refer to the SoSafe Configurable Project Report.</p>		

<b>⚠ WARNING</b>
<p><b>UNINTENDED EQUIPMENT OPERATION</b></p> <ul style="list-style-type: none"> <li>You must carry out a risk assessment in accordance with ISO 12100.</li> <li>Validate the entire system/machine in accordance with the required performance level and risk assessment.</li> </ul> <p><b>Failure to follow these instructions can result in death, serious injury, or equipment damage.</b></p>

Regular proof test intervals as defined by safety standards are required. Observe the required test cycles according to your application.

# Modular Safety Controller System

## Presentation

The XPSMCM functional safety offer consists of an XPSMCMCP0802(G), XPSMCMC10804(G) or XPSMCMC10804E(G) Modular Safety Controller, which can be configured using the SoSafe Configurable software (see Modular Safety Controller - Library and Programming Guide). The controllers have eight safety-related inputs and two or four dual-channel solid-state safety-related outputs depending on the controller. Expansion input and output modules can be connected to the controller via the *backplane expansion bus*, page 155. Together, these references form the structural basis of a functional safety system.

The Modular Safety Controller XPSMCMC10804E(G) features an Industrial Ethernet based Multi-protocol interface.

The system may include a number of expansion modules up to a maximum of 14, with not more than four I/O modules of the same reference. The number of relay modules XPSMCMER0002(G), XPSMCMER0004(G) and XPSMCMER0008(G) which can be installed is limited by the number of OSSD outputs and status outputs of the system.

With 14 expansion modules, the system supports up to 128 inputs, 16 dual-channel safety-related outputs, and 32 status outputs. The controller and its expansion modules communicate via the 5-way backplane expansion bus physically arranged on the back of the controller and expansion modules. However, if the *Network* function block is used in the configuration, a maximum of 9 expansion modules can be used with a controller.

In addition, fieldbus inputs and fieldbus probes can be used for non-safety-related commands through the addition of fieldbus expansion modules. The maximum of available fieldbus inputs and fieldbus probes depends on the Modular Safety Controller.

SoSafe Configurable enables you to create simple to complex configurations with the mixture of safety-related functions and logic; such as the combination of muting function with timers or counters.

The configuration created on the PC is sent to the controller as follows:

- For XPSMCMCP0802(G) controller, through a USB (PC) to Mini B USB (controller) cable.
- For XPSMCMC10804(G) controller:
  - For firmware versions less than v8.0.0, through USB (PC) to Mini B USB (controller) cable.
  - For firmware version v8.0.0 or greater, through USB (PC) to USB-C (controller) cable.
- For XPSMCMC10804E(G) controller, through a USB (PC) to USB-C (controller) cable.

The configuration resides in the Modular Safety Controller and can also be saved on the optional memory card accessory XPSMCMME0000, page 153. The configuration can therefore quickly be copied to another Modular Safety Controller.

The Modular Safety Controller is capable of monitoring the following safety-related sensors and command devices:

- Optoelectronic sensors (safety-related light curtains, scanners, safety-related photo cells)
- Mechanical switches
- Safety-related pressure-sensitive mats
- Emergency stops
- Two-hand controls
- Enabling devices

- Magnetic switches
- Proximity switches
- Encoders

## Controller Modules

The following controller modules are available:

Controller module	Type	Description
XPSMCMCP0802(G) , page 36 or XPSMCMCP0802BC(G)	CP0802	<ul style="list-style-type: none"> <li>• 8 safety-related inputs</li> <li>• 2 dual-channel solid-state safety-related outputs (Output Signal Switching Device, OSSD).</li> </ul> <p><b>NOTE:</b> XPSMCMCP0802BC(G) is delivered with the backplane connector.</p>
XPSMCMC10804(G), page 44 or XPSMCMC10804B(G)	C10804	<ul style="list-style-type: none"> <li>• 8 safety-related inputs</li> <li>• 4 solid-state safety-related outputs which can be used as 4 single or 2 dual (Output Signal Switching Device, OSSD).</li> </ul> <p><b>NOTE:</b> XPSMCMC10804B(G) is delivered with the backplane connector.</p>
XPSMCMC10804E(G), page 54 or XPSMCMC10804BE(G)	C10804E	<ul style="list-style-type: none"> <li>• 8 safety-related inputs</li> <li>• 4 solid-state safety-related outputs which can be used as 4 single or 2 dual (Output Signal Switching Device, OSSD).</li> <li>• Industrial Ethernet based communication is embedded (Multi-protocol EtherCAT, Ethernet/IP, Modbus TCP and Profinet).</li> </ul> <p><b>NOTE:</b> XPSMCMC10804BE(G) is delivered with the backplane connector.</p>

## I/O Expansion Modules

The following input and output expansion modules are available:

Input and output expansion module	Type	Description
XPSMCMDO00042A(G), page 92	DO042A	<ul style="list-style-type: none"> <li>• 4 single-channel solid-state safety-related outputs (Output Signal Switching Device, OSSD).</li> <li>• With this module, the system can provide 4 safety-related higher current outputs.</li> </ul>
XPSMCMAI0200(G), page 67	AI02	<ul style="list-style-type: none"> <li>• 2 configurable analog input channels.</li> <li>• With this module, a wide range of analog sensors can be used in the system.</li> </ul>
XPSMCMAI0400(G), page 67	AI04	<ul style="list-style-type: none"> <li>• 4 configurable analog input channels.</li> <li>• With this module, a wide range of analog sensors can be used in the system.</li> </ul>
XPSMCMMX0804(G), page 136	MX0804	<ul style="list-style-type: none"> <li>• 8 safety-related inputs</li> <li>• 4 solid-state safety-related outputs which can be used as 4 single or 2 dual (Output Signal Switching Device, OSSD).</li> </ul>
XPSMCMDO0004S(G), page 100	DO04S	<ul style="list-style-type: none"> <li>• 4 single-channel solid-state safety-related outputs (Output Signal Switching Device, OSSD).</li> <li>• With this module, the system can provide 4 safety-related outputs.</li> </ul>
XPSMCMDO0008C1(G), page 107	DO08C1	<ul style="list-style-type: none"> <li>• 8 status outputs for PL c, SIL 1</li> <li>• With this module, the number of inputs in the system can be increased to allow more external devices to be connected.</li> </ul>
XPSMCMDO0016C1(G), page 111	DO16C1	<ul style="list-style-type: none"> <li>• 16 status outputs for PL c, SIL 1</li> <li>• With this module, the number of status outputs in the system can be increased to allow more external devices to be connected.</li> </ul>
XPSMCMMX0802(G), page 131	MX0802	<ul style="list-style-type: none"> <li>• 8 safety-related inputs</li> <li>• 2 dual-channel solid-state safety-related outputs (Output Signal Switching Device, OSSD).</li> </ul>

Input and output expansion module	Type	Description
XPSMCM DI0800(G), page 77	DI08	<ul style="list-style-type: none"> <li>8 safety-related inputs</li> <li>With this module, the number of inputs in the system can be increased to allow more external devices to be connected.</li> </ul>
XPSMCM DI1600(G), page 77	DI16	<ul style="list-style-type: none"> <li>16 safety-related inputs</li> <li>With this module, the number of inputs in the system can be increased to allow more external devices to be connected.</li> </ul>
XPSMCM DI1200MT(G), page 81	DI12M	<ul style="list-style-type: none"> <li>Application-specific module dedicated to safety mats.</li> <li>Provides 8 test outputs for line control monitoring.</li> <li>With this module, the number of inputs in the system can be increased to allow more external devices to be connected.</li> </ul>
XPSMCM DO0002(G), page 85	DO02	<ul style="list-style-type: none"> <li>2 dual-channel solid-state safety-related output pairs for connection to contactors or drives.</li> </ul>
XPSMCM DO0004(G), page 85	DO04	<ul style="list-style-type: none"> <li>4 dual-channel solid-state safety-related output pairs for connection to contactors or drives.</li> </ul>
XPSMCM ER0002(G), page 116	ER02	<ul style="list-style-type: none"> <li>2 forcibly guided contact safety-related relay output module (2 NO and 1 NC) without backplane connection.</li> <li>The XPSMCMER0002(G) module is not connected to the backplane expansion bus.</li> </ul>
XPSMCM ER0004(G), page 116	ER04	<ul style="list-style-type: none"> <li>4 forcibly guided contact safety-related relay output module (2 groups of 2 NO and 1 NC) without backplane connection.</li> <li>The XPSMCMER0004(G) module is not connected to the backplane expansion bus.</li> </ul>
XPSMCM ER0008(G), page 116	ER08	<ul style="list-style-type: none"> <li>8 forcibly guided contact safety-related relay output module (4 groups of 2 NO and 1 NC) without backplane connection.</li> <li>The XPSMCMER0008(G) module is not connected to the backplane expansion bus.</li> </ul>
XPSMCM R00004(G), page 124	R04	<ul style="list-style-type: none"> <li>4 forcibly guided contact safety-related relay output (4x 2 NO) module without backplane connection.</li> <li>Expansion module with 4 independent safety-related relay outputs and the corresponding 4 inputs for the external feedback contacts (EDM).</li> <li>The relay can be configured according to Category 1, 2 and 4 architectures.</li> </ul>
XPSMCM R00004DA(G), page 124	R04DA	<ul style="list-style-type: none"> <li>4 forcibly guided contact safety-related relay output (4x 2 NO) module without backplane connection.</li> <li>Expansion module with 4 independent safety-related relay outputs and the corresponding 4 inputs for the external feedback contacts (EDM).</li> <li>The relay can be configured according to Category 1, 2 and 4 architectures.</li> <li>Contains 8 non-safety-related status outputs.</li> </ul>
XPSMCM MEN****(G), page 144	<ul style="list-style-type: none"> <li>PROX</li> <li>E01HT</li> <li>E01SC</li> <li>E01TT</li> <li>E02HT</li> <li>E02SC</li> <li>E02TT</li> </ul>	<ul style="list-style-type: none"> <li>Modules for monitoring speed by proximity sensors, and, depending on the reference, safety encoders with SinCos, HTL or TTL interface.</li> <li>The XPSMCMEN****(G) expansion units can be used to control the following (up to PLe): <ul style="list-style-type: none"> <li>Zero speed, maximum speed, speed range;</li> <li>Direction of movement, rotation/translation</li> </ul> </li> <li>Up to 4 speed thresholds can be set for each logic output (axis).</li> <li>Each unit incorporates two logic outputs that can be configured using SoSafe Configurable and is thus capable of controlling up to two independent axes.</li> </ul>

## Communication Modules

The following communication modules are available:

Communication module	Type	Description
XPSMCMCO0000S*(G), page 149	SCOM1, SCOM2	<ul style="list-style-type: none"> <li>The XPSMCMCO0000S1(G) and XPSMCMCO0000S2(G) units are used to build remote functional safety islands between controller and I/O expansion modules at distance (&lt; 50 m / 164 ft) between islands and up to 6 islands.</li> <li>Two XPSMCMCO0000S1(G) or XPSMCMCO0000S2(G) expansion modules can be connected using an RS-485 shielded cable, page 156.</li> </ul>
XPSMCMCO0000**(G)	<b>CAN , ETH, ECT, EIP, MBS, MTP, PDP</b>	The fieldbus expansion modules allow connection to the most common industrial fieldbus systems for diagnostics and data transmission. Refer to the Modular Safety Controller, Communication Guide.

## Accessories

The following accessories are available:

Accessories	Type	Description
TCSXCNAMUM3P, page 153	USB/Mini B USB configuration cable	Cable for configuring both the XPSMCMCP0802(G) controller and fieldbus communication modules
XPSMCMME0000, page 153	Memory card	The memory card can be installed in the Modular Safety Controller and is used to save/restore the hardware/software configuration
XPSMCMCN0000SG, page 155	Backplane expansion connector	<p>The connector allows you to add expansion input/output and communication modules to the Modular Safety Controller. The Modular Safety Controller requires one XPSMCMCN0000SG connector; the expansion modules are delivered with the connector.</p> <p><b>NOTE:</b> Modular Safety Controllers of reference XPSMCMCP0802BC(G), XPSMCMC10804B(G) or XPSMCMC10804BE(G) are delivered with the backplane connector.</p>
TSXS CMCN0**, page 156	RS485 cables	RS485 serial interface shielded cables are used between the Bus expansion communications modules to create decentralized safety-related islands. The cable is available in 10 m (32.81 ft), 25 m (82.02 ft) and 50 m (164.04 ft) lengths.
TSXESPPM***, page 157 TSXESPP3***, page 158	Encoder splitter cables	An encoder splitter cable is used to split the motor encoder feedback signal. One signal is then directed to the drive and one to the safety-related speed monitoring module. The cables is available in 1 m (3.28 ft), 3 m (9.84 ft), and 5 m (16.4 ft) lengths.

## Scope of Delivery

### For the Controllers

Each controller is provided with:

- Instruction sheet
- Backplane connector XPSMCMCN0000SG (provided with XPSMCMCP0802BC(G), XPSMCMC10804B(G) or XPSMCMC10804BE(G) only; controllers with a reference without "BC" or "B" are delivered without backplane connector for stand-alone use)
- Controllers whose reference number have a suffix "G" are delivered with spring terminal blocks, the other controllers with screw terminal blocks

**NOTE:** For each controller, you must order the following items separately as optional accessories:

- USB/Mini B USB or USB/USB-C configuration cable, page 153
- XPSMCMME0000: Memory card, page 153
- XPSMCMCN0000SG: Backplane expansion connector, page 155 (except for the references XPSMCMCP0802BC(G), XPSMCMC10804B(G) or XPSMCMC10804BE(G)).

## For the Modules

Each expansion module including fieldbus and specific modules is provided with:

- Instruction sheet
- Backplane XPSMCMCN0000SG connector (except for XPSMCMER00••(G) modules because they are not connected to the backplane expansion bus)
- Modules whose reference number have a suffix “G” are delivered with spring terminal blocks, the other modules with screw terminal blocks

# Technical Data

## What's in This Chapter

General System Characteristics ..... 24  
 Mechanical Dimensions ..... 26

## General System Characteristics

### General Characteristics

General characteristics			
Rated voltage	24 Vdc ± 20 % (PELV supply)		
Dissipated power	3 W maximum (per module)		
Overvoltage category	II		
Ambient operating temperature	-10...+55 °C (14...131 °F), for vertical or horizontal mounting position		
Storage temperature	-20...+85 °C (-4...185 °F)		
Relative humidity	10...95%		
Maximum operation altitude	2000 m (6562 ft)		
Pollution degree	2		
Vibration resistance (EN 61496-1)	+/- 0.35 mm (0.014 in) 10...55 Hz		
Bump resistance (EN 61496-1)	10 g (16 ms half-sine)		
<b>XPSMCMCP0802(G) Response time (ms)</b>  The response time depends on the following parameters: <ul style="list-style-type: none"> <li>• Number of expansion modules installed</li> <li>• Number of operators</li> <li>• Number of OSSD outputs</li> <li>• Status outputs</li> </ul> For the overall system response time, refer to the one calculated by the SoSafe Configurable software (see project report).  T <sub>Input_filter</sub> = filtering time set in the project for the inputs. For details, refer to the Input functions (see Modular Safety Controller, Library and Programming Guide).	Controller (XPSMCMCP0802(G))	10.6...12.6	+ T <sub>Input_filter</sub>
	Controller + 1 expansion module	11.8...26.5	+ T <sub>Input_filter</sub>
	Controller + 2 expansion modules	12.8...28.7	+ T <sub>Input_filter</sub>
	Controller + 3 expansion modules	13.9...30.8	+ T <sub>Input_filter</sub>
	Controller + 4 expansion modules	15...33	+ T <sub>Input_filter</sub>
	Controller + 5 expansion modules	16...35	+ T <sub>Input_filter</sub>
	Controller + 6 expansion modules	17...37.3	+ T <sub>Input_filter</sub>
	Controller + 7 expansion modules	18.2...39.5	+ T <sub>Input_filter</sub>
	Controller + 8 expansion modules	19.3...41.7	+ T <sub>Input_filter</sub>
	Controller + 9 expansion modules	20.4...43.8	+ T <sub>Input_filter</sub>
	Controller + 10 expansion modules	21.5...46	+ T <sub>Input_filter</sub>
	Controller + 11 expansion modules	22.5...48.1	+ T <sub>Input_filter</sub>
	Controller + 12 expansion modules	23.6...50.3	+ T <sub>Input_filter</sub>
	Controller + 13 expansion modules	24.7...52.5	+ T <sub>Input_filter</sub>
Controller + 14 expansion modules	25.8...54.6	+ T <sub>Input_filter</sub>	
<b>XPSMCMC10804(G) Response time (ms)</b>  The response time depends on the following parameters: <ul style="list-style-type: none"> <li>• Number of expansion modules installed</li> <li>• Number of operators</li> <li>• Number of OSSD outputs</li> <li>• Status outputs</li> </ul> For the overall response time, refer to the one calculated by the SoSafe Configurable software (see project report).	Controller (XPSMCMC10804(G))	12.75...14.75	+ T <sub>Input_filter</sub>
	Controller + 1 expansion module	13.83...37.84	+ T <sub>Input_filter</sub>
	Controller + 2 expansion modules	14.91...40.00	+ T <sub>Input_filter</sub>
	Controller + 3 expansion modules	15.99...42.16	+ T <sub>Input_filter</sub>
	Controller + 4 expansion modules	17.07...44.32	+ T <sub>Input_filter</sub>
	Controller + 5 expansion modules	18.15...46.48	+ T <sub>Input_filter</sub>
	Controller + 6 expansion modules	19.23...48.64	+ T <sub>Input_filter</sub>

General characteristics			
<p><math>T_{Input\_filter}</math> = filtering time set in the project for the inputs. For details, refer to the Input functions (see Modular Safety Controller, Library and Programming Guide).</p>	Controller + 7 expansion modules	20.31...50.80	+ $T_{Input\_filter}$
	Controller + 8 expansion modules	21.39...52.96	+ $T_{Input\_filter}$
	Controller + 9 expansion modules	22.47...55.12	+ $T_{Input\_filter}$
	Controller + 10 expansion modules	23.55...57.28	+ $T_{Input\_filter}$
	Controller + 11 expansion modules	24.63...59.44	+ $T_{Input\_filter}$
	Controller + 12 expansion modules	25.71...61.60	+ $T_{Input\_filter}$
	Controller + 13 expansion modules	26.79...63.76	+ $T_{Input\_filter}$
	Controller + 14 expansion modules	27.87...65.92	+ $T_{Input\_filter}$
<p><b>XPSMCMC10804E(G) Response time (ms)</b></p> <p>The response time depends on the following parameters:</p> <ul style="list-style-type: none"> <li>• Number of expansion modules installed</li> <li>• Number of operators</li> <li>• Number of OSSD outputs</li> <li>• Status outputs</li> </ul> <p>For the overall system response time, refer to the one calculated by the SoSafe Configurable software (see project report).</p> <p><math>T_{Input\_filter}</math> = filtering time set in the project for the inputs. For details, refer to the Input functions (see Modular Safety Controller, Library and Programming Guide).</p>	Controller (XPSMCMC10804E(G))	13.95...19.95	+ $T_{Input\_filter}$
	Controller + 1 expansion module	15.03...40.16	+ $T_{Input\_filter}$
	Controller + 2 expansion modules	16.11...42.32	+ $T_{Input\_filter}$
	Controller + 3 expansion modules	17.19...44.48	+ $T_{Input\_filter}$
	Controller + 4 expansion modules	18.27...46.64	+ $T_{Input\_filter}$
	Controller + 5 expansion modules	19.35...48.80	+ $T_{Input\_filter}$
	Controller + 6 expansion modules	20.43...50.96	+ $T_{Input\_filter}$
	Controller + 7 expansion modules	21.51...53.12	+ $T_{Input\_filter}$
	Controller + 8 expansion modules	22.59...55.28	+ $T_{Input\_filter}$
	Controller + 9 expansion modules	23.67...57.44	+ $T_{Input\_filter}$
	Controller + 10 expansion modules	24.75...59.60	+ $T_{Input\_filter}$
	Controller + 11 expansion modules	25.83...61.76	+ $T_{Input\_filter}$
	Controller + 12 expansion modules	26.91...63.92	+ $T_{Input\_filter}$
	Controller + 13 expansion modules	27.99...66.08	+ $T_{Input\_filter}$
	Controller + 14 expansion modules	29.07...68.24	+ $T_{Input\_filter}$

**NOTE:** Specific characteristics for each reference can be found in Component-Specific Hardware Information, page 35.

## Housing Characteristics

Housing characteristics	
Housing material	Polyamide
Housing degree of protection	IP20
Terminal blocks degree of protection	IP2x
Mounting	35 mm DIN rail according to EN/IEC 60715
Mounting position	Vertical or horizontal
Dimensions (h x l x d)	<ul style="list-style-type: none"> <li>• with screw terminals: 108 x 22.5 x 114.5 mm (4.25 x 0.89 x 4.5 in)</li> <li>• with spring terminals: 118.5 x 22.5 x 114.5 mm (4.67 x 0.89 x 4.5 in)</li> </ul> <p>For XPSMCMC10804E(G) and XPSMCMER0008(G).</p> <ul style="list-style-type: none"> <li>• with screw terminals: 108 x 45 x 114.5 mm (4.25 x 1.78 x 4.5 in)</li> <li>• with spring terminals: 118.5 x 45 x 114.5 mm (4.67 x 1.78 x 4.5 in)</li> </ul>

# Mechanical Dimensions

## Overview

Mount the modules (Modular Safety Controller and any I/O expansion modules) in an electric cabinet with an IP54 degree of protection. The minimum clearance below and above the controller is 40 mm (1.57 in). Allow at least 100 mm (3.93 in) distance between the cabinet door and the front face of the module(s). There are no clearances required on the left or right side of the module(s), but for XPSMCMDO00042A(G) module an additional distance to adjacent modules is mandatory, page 92. Other equipment in proximity may require larger distances and those clearances must also be taken into account.

## Dimensions of the XPSMCMCP0802(G), XPSMCMC10804(G) and Single-Wide Modules

The graphic indicates the dimensions of the XPSMCMCP0802(G) and XPSMCMC10804(G) controllers, as well as the single-wide expansion modules:

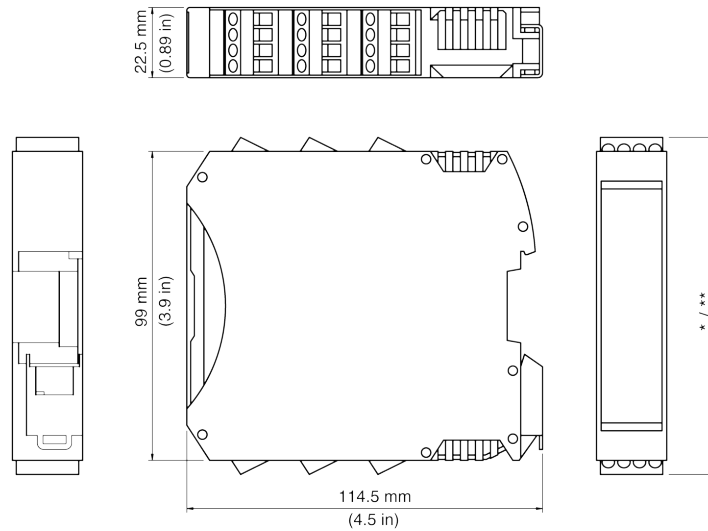

- \* Screw terminals 108 mm (4.25 in)
- \*\* Spring terminals 118 mm (4.67 in)

## Dimensions of the XPSMCMC10804E(G) Controller

The graphic indicates the dimensions of the XPSMCMC10804E(G) controller:

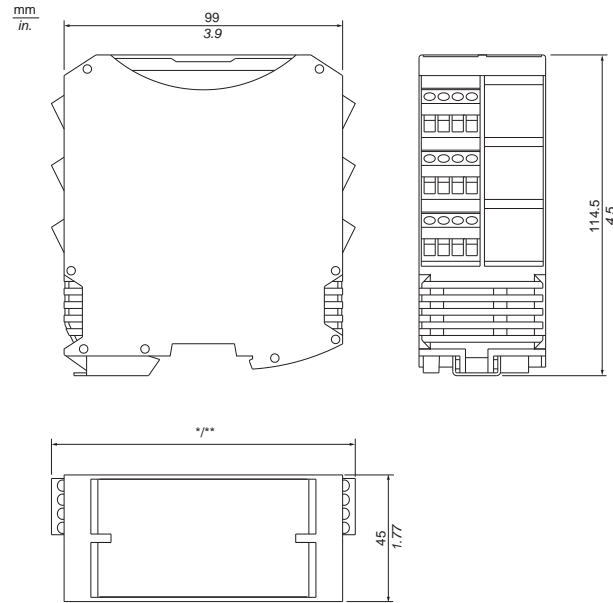

\* Screw terminals 108 mm (4.25 in)

\*\* Spring terminals 118 mm (4.67 in)

### Dimensions of the XPSMCMER0008(G) Module

The graphic indicates the dimensions of the XPSMCMER0008(G) module:

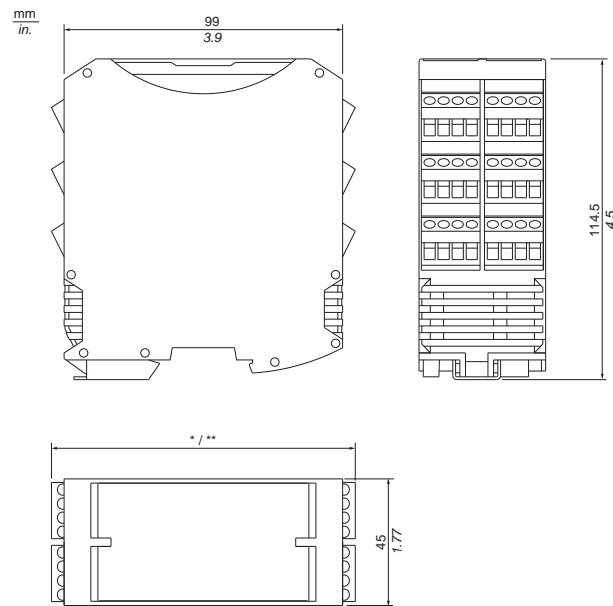

\* Screw terminals 108 mm (4.25 in)

\*\* Spring terminals 118 mm (4.67 in)

# Electrical Requirements

## What's in This Chapter

Wiring Best Practices.....28  
 Terminal Blocks.....33

## Wiring Best Practices

### Overview

This section describes the wiring guidelines and associated best practices to be respected when using the XPSMCM• Modular Safety Controller system.

** DANGER**

**HAZARD OF ELECTRIC SHOCK, EXPLOSION, OR ARC FLASH**

- Disconnect all power from all equipment including connected devices prior to removing any covers or doors, or installing or removing any accessories, hardware, cables, or wires except under the specific conditions specified in the appropriate hardware guide for this equipment.
- Always use a properly rated voltage sensing device to confirm the power is off where and when indicated.
- Replace and secure all covers, accessories, hardware, cables, and wires and confirm that a proper ground connection exists before applying power to this equipment.
- Use only the specified voltage when operating this equipment and any associated equipment.

**Failure to follow these instructions will result in death or serious injury.**

** DANGER**

**HAZARD OF ELECTRIC SHOCK, EXPLOSION OR ARC FLASH**

- Do not use the equipment described herein to supply external equipment.
- Do not make contact with terminals until the power has been confirmed removed.
- Follow all electrical safety regulations and standards (for example, lockout/tag-out, phase grounding, barriers) to reduce the possibility of contact with hazardous voltages in the work area.
- Complete thorough hardware tests and system commissioning to verify that line voltages are not present on the control circuits before using your hardware operationally.

**Failure to follow these instructions will result in death or serious injury.**

## ⚠ WARNING

### LOSS OF CONTROL

- Perform a Failure Mode and Effects Analysis (FMEA), or equivalent risk analysis, of your application, and apply preventive and detective controls before implementation.
- Provide a fallback state for undesired control events or sequences.
- Provide separate or redundant control paths wherever required.
- Supply appropriate parameters, particularly for limits.
- Review the implications of transmission delays and take actions to mitigate them.
- Review the implications of communication link interruptions and take actions to mitigate them.
- Provide independent paths for control functions (for example, emergency stop, over-limit conditions, and error conditions) according to your risk assessment, and applicable codes and regulations.
- Apply local accident prevention and safety regulations and guidelines.<sup>1</sup>
- Test each implementation of a system for proper operation before placing it into service.

**Failure to follow these instructions can result in death, serious injury, or equipment damage.**

<sup>1</sup> For additional information, refer to NEMA ICS 1.1 (latest edition), *Safety Guidelines for the Application, Installation, and Maintenance of Solid State Control* and to NEMA ICS 7.1 (latest edition), *Safety Standards for Construction and Guide for Selection, Installation and Operation of Adjustable-Speed Drive Systems* or their equivalent governing your particular location.

## Wiring Guidelines

The following rules must be applied when wiring a XPSMCM• Modular Safety Controller system:

- I/O and communication wiring must be separate from the power wiring. Route these two types of wiring in separate cable ducting.
- Verify that the operating conditions and environment are within the specification values found in the technical characteristics.
- Use proper wire sizes to meet voltage and current requirements.
- Use copper conductors (required).
- Use twisted pair, shielded cables for networks, and fieldbus.
- The maximum length of cables connected to inputs and of cables connecting controllers via the Network function block is 100 m (328 ft). There are other limiting factors related to resistance and capacitance of the cable. The values can be found in the technical data of each module.

To help minimize the effects of electromagnetic interference, use shielded, properly grounded cables for all I/O susceptible to electrical noise and all communication connections. If you do not use shielded cable for these connections, electromagnetic interference can cause signal degradation. Degraded signals can cause the controller or attached modules and equipment to perform in an unintended manner.

## ⚠ WARNING

### UNINTENDED EQUIPMENT OPERATION

- Use shielded cables for communication signals and any I/O that may be susceptible to electromagnetic radiation.
- Ground cable shield at a single point<sup>(1)</sup>.
- Route communication and I/O cables separately from power cables.

**Failure to follow these instructions can result in death, serious injury, or equipment damage.**

<sup>1</sup>Multipoint grounding is permissible (and in some cases inevitable) if connections are made to an equipotential ground plane dimensioned to help avoid cable shield damage in the event of power system short-circuit currents.

The use of shielded cables requires compliance with the following wiring rules:

- For protective ground connections (PE), metal conduit or ducting can be used for part of the shielding length, provided there is no break in the continuity of the ground connections. For functional ground (FE), the shielding is intended to attenuate electromagnetic interference and the shielding must be continuous for the length of the cable. If the purpose is both functional and protective, as is often the case for communication cables, the cable must have continuous shielding.
- Wherever possible, keep cables carrying one type of signal separate from the cables carrying other types of signals or power.

## Protective Ground (PE) on the Backplane

The protective ground (PE) should be connected to the conductive backplane by a heavy-duty wire, usually a braided copper cable with the maximum allowable cable section.

## Shielded Cables Connections

Shielded I/O cables and fieldbus communication signals must be securely connected to ground. The I/O shields may be connected either to the functional ground (FE) or to the protective ground (PE) of your installation. The fieldbus communication cable shields must be connected to the protective ground (PE) with a connecting clamp secured to the conductive backplane of your installation.

The shielding of any Modbus cabling must be connected to the protective ground (PE).











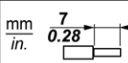



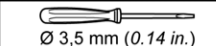

## ⚠ DANGER

### HAZARD OF ELECTRIC SHOCK

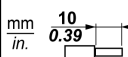
Ensure that a proper ground exists between the integrated ground clamp of the equipment and the mounting rail to which it is attached.

**Failure to follow these instructions will result in death or serious injury.**

## Cable Types and Wire Sizes

<b>Cable types and wire sizes</b>								
for a 5.08 pitch removable <b>screw</b> terminal block								
								
mm <sup>2</sup>	0.2...2.5	0.2...2.5	0.25...2.5	0.25...1.5	2 x 0.2...1	2 x 0.2...1.5	2 x 0.25...1	2 x 0.5...1.5
AWG	24...14	24...14	23...14	23...16	2 x 24...18	2 x 24...16	2 x 23...18	2 x 20...16
				N•m	0.5			
Ø 3,5 mm (0.14 in.)				lb-in	4.42			
for a 5.08 pitch removable <b>spring</b> terminal block (used by XPSMCM***G).								
								
mm <sup>2</sup>	0.2...2.5	0.2...2.5	0.25...2.5	0.25...2.5	2 x 0.5...1			
AWG	24...14	24...14	23...14	23...14	2 x 20...18			
The following instructions concerning connection cables must be observed:								
<ul style="list-style-type: none"> <li>• Use 60/75 °C copper (Cu) conductor only. Maximum cable length 100 m (328 ft).</li> <li>• Cables used for connections of longer than 50 m (164 ft) must have a cross-section of at least 1 mm<sup>2</sup> (AWG 16).</li> </ul>								

Spring cage clamp connectors have the added advantage of requiring little maintenance in order to retain the tension on the wire. However, screw connectors do require tightening maintenance on a regular schedule.

**⚠️⚠️ DANGER**

**LOOSE WIRING CAUSES ELECTRIC SHOCK**

Tighten connections in conformance with the torque specifications.

**Failure to follow these instructions will result in death or serious injury.**

**⚠️ DANGER**

**FIRE HAZARD**

Use only the correct wire sizes for the maximum current capacity of the I/O channels and power supplies.

**Failure to follow these instructions will result in death or serious injury.**

The spring clamp connectors of the terminal block are designed for only one wire or one cable end. Two wires to the same connector must be installed with a double wire cable end to help prevent loosening.

**⚠️⚠️ DANGER**

**LOOSE WIRING CAUSES ELECTRIC SHOCK**

Do not insert more than one wire per connector of the spring terminal blocks unless using a double wire cable end (ferrule).

**Failure to follow these instructions will result in death or serious injury.**

## Protecting Outputs from Inductive Load Damage

Depending on the load, a protection circuit may be needed for the outputs on the controllers and certain modules. Inductive loads using DC voltages may create voltage reflections resulting in overshoot that will damage or shorten the life of output devices.

<b>⚠ CAUTION</b>
<b>OUTPUT CIRCUIT DAMAGE DUE TO INDUCTIVE LOADS</b>
Use an appropriate external protective circuit or device to reduce the risk of inductive direct current load damage.
<b>Failure to follow these instructions can result in injury or equipment damage.</b>

If your controller or module contains relay outputs, these types of outputs can support up to 240 Vac. Inductive damage to these types of outputs can result in welded contacts and loss of control. Each inductive load must include a protection device such as a peak limiter, RC circuit or flyback diode. Capacitive loads are not supported by these relays.

<b>⚠ WARNING</b>
<b>RELAY OUTPUTS WELDED CLOSED</b>
<ul style="list-style-type: none"> <li>Always protect relay outputs from inductive alternating current load damage using an appropriate external protective circuit or device.</li> <li>Do not connect relay outputs to capacitive loads.</li> </ul>
<b>Failure to follow these instructions can result in death, serious injury, or equipment damage.</b>

**Protective circuit A for relay outputs:** this protection circuit can be used for both AC and DC load power circuits.

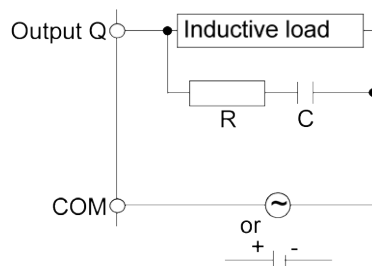

**C** 0.1 to 0.82  $\mu$ F (including capacitance of cables)

**R** Resistor of approximately the same resistance value as the load

**Protective circuit B for relay outputs:** this protection circuit can be used for DC load power circuits.

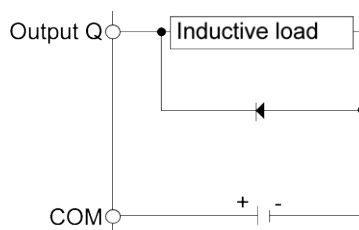

Use a diode with the following ratings:

- Reverse withstand voltage: power voltage of the load circuit x 10.
- Forward current: more than the load current.

**Protective circuit C:** this protection circuit can be used for both AC and DC load power circuits.

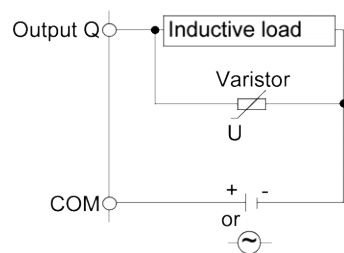

In applications where the inductive load is switched on and off frequently and/or rapidly, ensure that the continuous energy rating (J) of the varistor exceeds the peak load energy by 20 % or more.

The guidelines for component ratings are the same as for the relay output protection above.

## Terminal Blocks

### Presentation

The Modular Safety Controller references are provided with removable terminal blocks for the electrical connections. Each reference can have up to 48 (12 terminal blocks) terminals.

The following graphic shows an example with the maximum number of terminals:

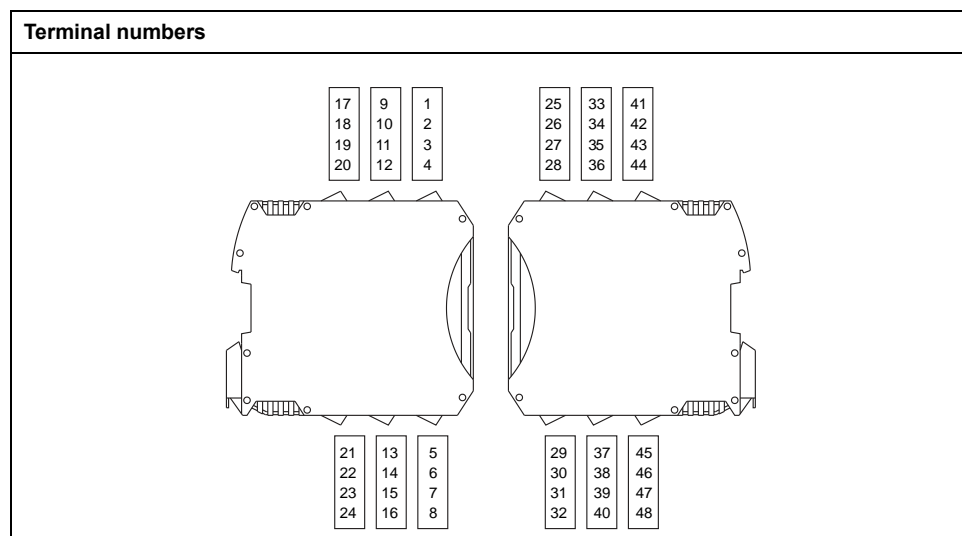

The terminal blocks are either screw or spring cage clamp terminal blocks depending on the reference.

## Removing and Inserting the I/O Terminal Block

To remove a terminal block, use a flat, insulated or non-conductive screwdriver as described in the following table:

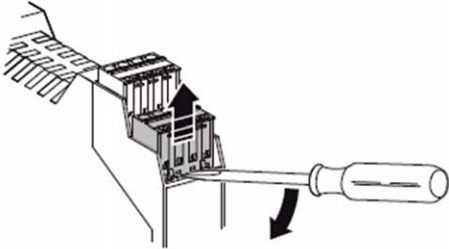
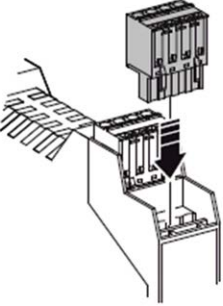
Step	Action
1	<p data-bbox="616 197 1390 248">Slide the tip of the screwdriver into the slit located between the front of the terminal block and the module to lift the terminal block up.</p>  <p data-bbox="660 557 1145 584"><b>NOTE:</b> You can remove the terminal block to wire it.</p>
2	<p data-bbox="616 622 1433 674">To put a terminal block in the module, slide it in the proper location until you hear it click into place.</p> 

---

# Component-Specific Hardware Information

## What's in This Part

Technical Features .....	36
Accessories .....	153

# Technical Features

## What's in This Chapter

XPSMCMCP0802(G) Modular Safety Controller .....	36
XPSMCMC10804(G) Modular Safety Controller .....	44
XPSMCMC10804E(G) Modular Safety Controller with Communication Embedded .....	54
XPSMCMAI0200(G) and XPSMCMAI0400(G) Analog Input Expansion Modules .....	67
XPSMCMDI0800(G) and XPSMCMDI1600(G) Input Expansion Modules .....	77
XPSMCMDI1200MT(G) Input Expansion Module .....	81
XPSMCMDO0002(G) and XPSMCMDO0004(G) Output Expansion Modules .....	85
XPSMCMDO00042A(G) Output Expansion Module .....	92
XPSMCMDO0004S(G) Output Expansion Module .....	100
XPSMCMDO0008C1(G) Output Expansion Module .....	107
XPSMCMDO0016C1(G) Output Expansion Module .....	111
XPSMCMER00••(G) Output Expansion Modules .....	116
XPSMCMRO0004DA(G) and XPSMCMRO0004(G) Output Expansion Modules .....	124
XPSMCMMX0802(G) Input/Output Expansion Module .....	131
XPSMCMMX0804(G) Input/Output Expansion Module .....	136
XPSMCMEN••••(G) Speed Monitoring Expansion Modules .....	144
XPSMCMCO0000S1(G) and XPSMCMCO0000S2(G) Communication Expansion Modules .....	149

## XPSMCMCP0802(G) Modular Safety Controller

### Controller and Functional Description

#### Presentation

XPSMCMCP0802(G) is a Modular Safety Controller providing eight safety-related inputs and two safety-related, dual-channel-outputs, which can be configured using SoSafe Configurable. In addition, the Modular Safety Controller can be combined with a number of expansion modules through the backplane expansion bus.

**Configuration of the controller:** The XPSMCMCP0802(G) Modular Safety Controller requires a USB (computer) to Mini B USB (controller) configuration cable connected to a PC via a USB 2.0 (or greater) port to configure the controller. The XPSMCMCP0802(G) requires SoSafe Configurable to configure the controller and system (for more information, refer to the *Modular Safety Controller Library and Programming Guide* (see Modular Safety Controller, Library and Programming Guide)).

**Optional memory card:** An optional backup memory card can be installed in the XPSMCMCP0802(G) Modular Safety Controller and used to store the software configuration parameters.

#### Input MASTER\_ENABLE

The XPSMCMCP0802(G) Modular Safety Controller contains two enabling EN inputs: MASTER\_ENABLE1 and MASTER\_ENABLE2. These signals must both be permanently set to logic level 1 (24 Vdc) for the controller to operate. To disable the controller, deactivate the supply voltage to the inputs, logic level 0 (0 Vdc).

## Input RESTART (RST)

The *RESTART (RST)* signal input allows the XPSMCMCP0802(G) Modular Safety Controller to verify an EDM (External Device Monitoring) feedback signal (series of contacts) from external contactors, and to monitor manual or automatic operation.

<b>⚠ WARNING</b>
<p><b>UNINTENDED EQUIPMENT OPERATION</b></p> <ul style="list-style-type: none"> <li>• The <i>RESTART</i> command device must be installed outside the zone of operation in a position where the zone of operation and the entire work area concerned are clearly visible.</li> <li>• It must not be possible to operate the <i>RESTART</i> command device from inside the zone of operation.</li> </ul> <p><b>Failure to follow these instructions can result in death, serious injury, or equipment damage.</b></p>

Operation mode	EDM	Restart_fbk
Automatic	With K1_K2 control	
	Without K1_K2 control	
Manual	With K1_K2 control	
	Without K1_K2 control	

## Output STATUS (SIL 1/PL c in Accordance with Standard EN 61508:2010)

The status outputs are configurable digital diagnostic outputs that indicate the status of safety-related inputs and/or outputs.

<b>⚠ WARNING</b>
<p><b>INSUFFICIENT SAFETY-RELATED FUNCTIONS</b></p> <p>Do not use status outputs for safety-related purposes greater than SIL 1/PL c (EN 61508:2010).</p> <p><b>Failure to follow these instructions can result in death, serious injury, or equipment damage.</b></p>

The status outputs are SIL 1/PL c outputs configurable by means of SoSafe Configurable. Two status outputs are available on the XPSMCMCP0802(G) Modular Safety Controller.

## Output TEST

The *TEST* outputs are related to be used with the input circuits of the Modular Safety Controller.

The TEST outputs must be used to monitor the presence of cross circuits or short-circuits on the inputs. Connecting the test outputs helps to reach PL e in accordance with ISO 13849-1 and SILCL 3 in accordance with IEC 62061.

**NOTE:** These safety levels can also be obtained by applying other means of fault exclusion as described in ISO 13849-2.

**NOTE:** The test outputs of a specific module can only be linked to the inputs of the same module.

The maximum number of controllable inputs for each test outputs terminal is:

- Two inputs (parallel connection) for XPSMCMCP0802(G), XPSMCMX0802(G), XPSMCMCI0800(G), XPSMCMCI1200MT(G)
- Four inputs (parallel connection) for XPSMCMCI1600(G)

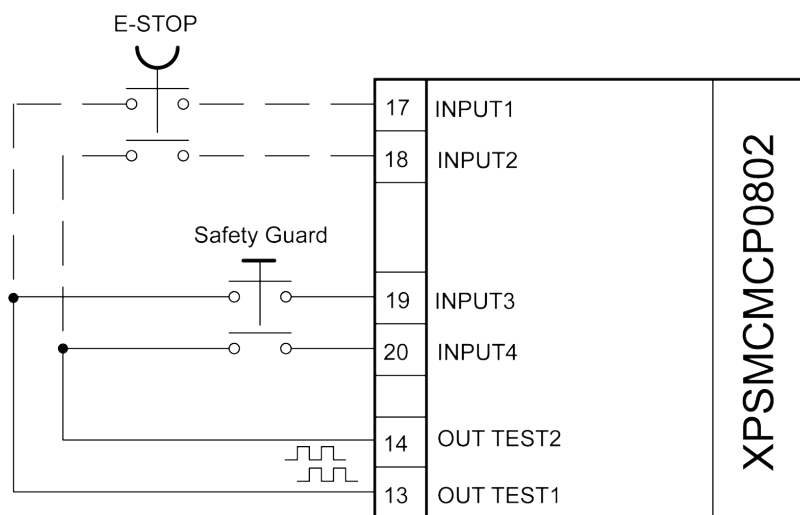

Type C, class 3 according to "ZVEI CB24I Ed.2" with a maximum test pulse duration of 120 µs.

### Solid-State Safety-Related Output (OSSD)

<b>⚠ WARNING</b>
<b>UNINTENDED EQUIPMENT OPERATION</b>
Do not connect any equipment to an OSSD unless the OSSD is appropriately configured with SoSafe Configurable.
<b>Failure to follow these instructions can result in death, serious injury, or equipment damage.</b>

The two OSSD safety-related outputs of the Modular Safety Controller are short-circuit protected. A Category 4 architecture requires redundancy, that is, two outputs.

The outputs are able to supply:

- In the ON condition:  $U_v - 0.75 V \dots U_v$   
where  $U_v = 24 V_{dc} \pm 20\%$
- In the OFF condition:  $0 \dots 2 V$  r.m.s.

The maximum load current of 400 mA (per OSSD). The minimum resistive load is 60 Ω.

The maximum capacitive load is 0.68 µF.

The maximum inductive load is 2 mH.

Type C, class 3 according to "ZVEI CB24I Ed.2" with a maximum test pulse duration of 120 µs.

The following table indicates how each OSSD output can be configured:

Automatic	The output is activated according to the configurations set by the SoSafe Configurable software, only if the corresponding <i>RESTART</i> input is connected to Uv (24 Vdc ± 20%).
Manual	The output is activated according to the configurations set by the SoSafe Configurable software, only if the level at the corresponding <i>RESTART</i> input changes from 0 Vdc to Uv (24 Vdc ± 20%).
Monitored	The output is activated according to the configurations set by the SoSafe Configurable software, only if the level at the corresponding <i>RESTART</i> input changes from 0 Vdc to Uv (24 Vdc ± 20%) and back to 0 Vdc.

## Connector Designations and Sample Wiring Diagrams

### Modular Safety Controller Connector Designations

Terminal	Signal	LED	Type	Description	Operation
1	24 VDC	PWR	-	24 Vdc power supply	-
2	MASTER_ENABLE1	EN	Input	Master enable 1	Input type 3 according to EN 61131-2. Maximum resistance 1.2 kΩ.
3	MASTER_ENABLE2	EN		Master enable 2	
4	0 VDC	PWR	-	0 Vdc power supply	-
5	OSSD1_A	OSSD1	Output	Safety-related output 1	PNP active at Uv (24 Vdc ± 20%).
6	OSSD1_B				
7	RESTART1	RST 1	Input	Feedback/Restart 1	Input type 3 according to EN 61131-2. Maximum resistance 1.2 kΩ.
8	OUT_STATUS 1	STATUS 1	Output	Configurable diagnostic output	Configurable output (SIL 1/PL c in accordance with EN 61508:2010)
9	OSSD2_A	OSSD2		Safety-related output 2	PNP active at Uv (24 Vdc ± 20%).
10	OSSD2_B				
11	RESTART2	RST 2	Input	Feedback/Restart 2	Input type 3 according to EN 61131-2. Maximum resistance 1.2 kΩ.
12	OUT_STATUS 2	STATUS 2	Output	Configurable diagnostic output	Configurable output (SIL 1/PL c in accordance with EN 61508:2010)
13	OUT_TEST1	-		Test output for detection of short circuits/cross circuits in input circuits	PNP active at 24 Vdc.
14	OUT_TEST2	-			
15	OUT_TEST3	-			
16	OUT_TEST4	-			
17	INPUT1	IN 1	Input	Safety-related input 1	Input type 3 according to EN 61131-2. Maximum resistance 1.2 kΩ.
18	INPUT2	IN 2		Safety-related input 2	
19	INPUT3	IN 3		Safety-related input 3	
20	INPUT4	IN 4		Safety-related input 4	
21	INPUT5	IN 5		Safety-related input 5	
22	INPUT6	IN 6		Safety-related input 6	
23	INPUT7	IN 7		Safety-related input 7	
24	INPUT8	IN 8		Safety-related input 8	

## Modular Safety Controller Sample Wiring Diagram

Category 3 wiring for XPSMCMCP0802(G):

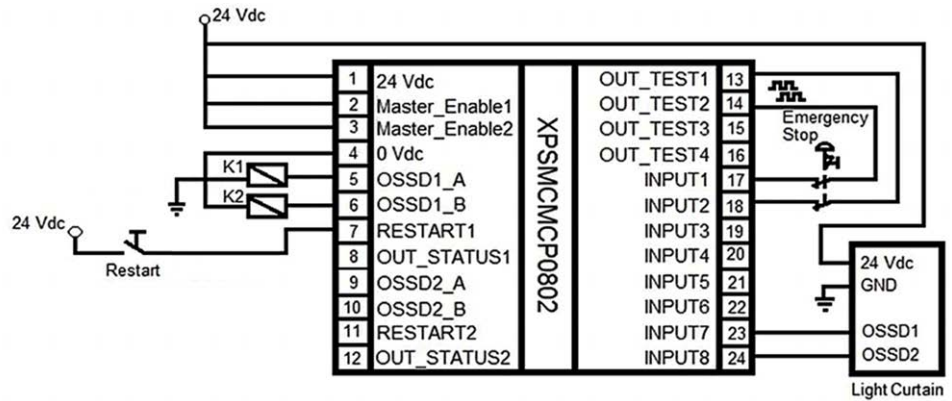

**NOTE:** Best practice dictates the use of fusing on the incoming 24 Vdc power, and sized appropriately for the requirements of the module.

Category 4 wiring for XPSMCMCP0802(G) with feedback of the contactors K1 and K2:

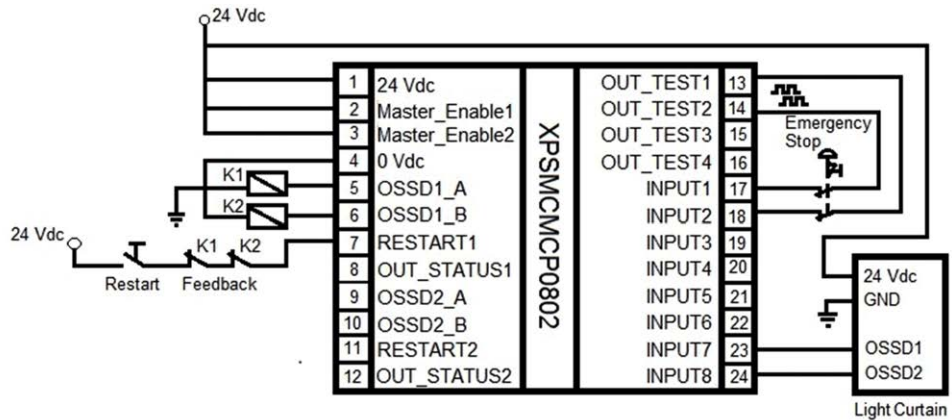

**NOTE:** Best practice dictates the use of fusing on the incoming 24 Vdc power, and sized appropriately for the requirements of the module.

# LED Indicators

## Front-Face View

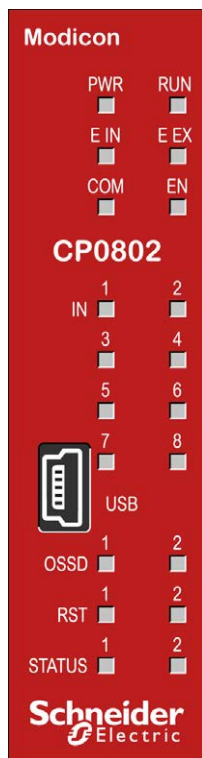

## Operation States

The following table describes the indication of the operation states of the XPSMCMCP0802(G) by means of the LEDs. The description assumes that the power LED (**PWR**) is ON:

<b>RUN</b> green	<b>E IN</b> red	<b>E EX</b> red	<b>COM</b> orange	<b>EN</b> blue	<b>IN 1...8</b> yellow	<b>OSSD 1...2</b> red/ green	<b>RST 1...2</b> yellow	<b>STATUS 1...2</b> yellow	<b>Meaning</b>
ON	ON	ON	ON	ON	ON	red	ON	ON	Power on - initial test
OFF	OFF	OFF	ON (maximum 1 s)	ON (maximum 1 s)	OFF	red	OFF	OFF	Memory card recognized
OFF	OFF	OFF	5 flashes	5 flashes	OFF	red	OFF	OFF	Writing/loading/ project to/from memory card
OFF	OFF	OFF	ON	OFF	OFF	red	OFF	OFF	Controller stopped
ON	OFF	OFF	ON = connected / OFF	ON <sup>(1)</sup> / OFF	Input state	red = output ON green = output OFF	ON = waiting for reboot / Flashing = no feedback	Output diagnostics	Normal operation

**(1)** MASTER\_ENABLE1 and MASTER\_ENABLE2 inputs are at state 1

## Troubleshooting

The following table describes the indication of detected errors of the XPSMCMCP0802(G) by means of the LEDs. The description assumes that the power LED (**PWR**) is ON:

Detected error	RUN green	E IN red	E EX red	COM orange	EN blue	IN 1...8 yellow	OSSD 1...2 red/ green	RST 1...2 yellow	STA- TUS 1...2 yellow	Solution
Internal error detected	OFF	2 or 3 flashes	OFF	OFF	OFF	OFF	red	OFF	OFF	Product non serviceable <sup>(1)</sup> .
Internal configuration not present	OFF	OFF	OFF	Slow flashes	OFF	OFF	red	OFF	OFF	Download the configuration to the controller <sup>(1)</sup> .
Module or node number not correct	OFF	OFF	OFF	Rapid flashes	OFF	OFF	red	OFF	OFF	Verify the hardware configuration and the terminal 2 and 3 of each expansion module.
Module unavailable or not ready	Rapid flashes	OFF	OFF	Rapid flashes	OFF	OFF	red	OFF	OFF	Verify the hardware configuration and the state of each expansion module.
External wiring error detected	ON	OFF	ON	ON = connected / OFF	OFF	Flashing = input with error	OFF	OFF	OFF	Verify all I/O connections.
Internal error detected	OFF	2 or 3 flashes	OFF	OFF	OFF	OFF	red	OFF	OFF	Product non serviceable <sup>(1)</sup> .
Configuration error detected	OFF	5 flashes	OFF	OFF	OFF	5 flashes				Download the configuration to the controller <sup>(1)</sup> .
OSSD output error	OFF	4 flashes	OFF	OFF	OFF	OFF	4 flashes	OFF	OFF	Verify solid-state safety-related output (OSSD)1/2 connections <sup>(1)</sup> .
Error in communication with expansion module	OFF	5 flashes	OFF	OFF	OFF	OFF	OFF	OFF	OFF	Reboot the system <sup>(1)</sup> .
Expansion module unit error	OFF	ON	OFF	OFF	OFF	OFF	OFF	OFF	OFF	Reboot the system. Verify which expansion module is in error and consult its troubleshooting guide.
Memory card error detected.	OFF	6 flashes	OFF	6 flashes	OFF	OFF	OFF	OFF	OFF	Replace the memory card, page 153.

(1) If the condition persists, contact your local Schneider Electric representative.

## Controller Characteristics

### Presentation

Controller-specific characteristics	
Reference description	Electronic housing maximum 24-poles, with locking latch mounting
Maximum number of inputs	128
Maximum number of outputs	16
Maximum number of expansion modules (excluding XPSMCMER00•(G))	14

Controller-specific characteristics	
Maximum number of expansion modules of the same reference (excluding XPSMCMER00••(G))	4
Unit enable (No./description)	2 / Input type 3 according to EN 61131-2. Maximum applicable resistance 1.2 kΩ.
Digital inputs (No./description)	8 / Input type 3 according to EN 61131-2. Maximum applicable resistance 1.2 kΩ.
Restart Input (No./description)	2 / EDM (External Device Monitoring) input type 3 according to EN 61131-2. Maximum applicable resistance 1.2 kΩ. / Possible automatic restart function or manual operation with restart pushbutton
Test output (No./description)	4 / to test for cross circuits - short circuits, maximum current 100 mA, nominal voltage 24 Vdc
Controller to controller by Network function	Maximum 10 Modular Safety Controllers with distance of up to 100 m (328 ft) between each controller.
Solid-state safety-related output (OSSD) (No./description)	2 pairs / solid-state safety-related outputs PNP active high <ul style="list-style-type: none"> <li>• The outputs are able to supply:                             <ul style="list-style-type: none"> <li>◦ In the ON condition: <math>U_v - 0.75 V \dots U_v</math> where <math>U_v = 24 V_{dc} \pm 20\%</math></li> <li>◦ In the OFF condition: 0 to 2 Vrms (root mean square)</li> </ul> </li> <li>• The maximum load current of 400 mA (per OSSD) corresponds to a minimum resistive load of 60 Ω.                             <ul style="list-style-type: none"> <li>◦ The maximum capacitive load is 0.68 μF.</li> <li>◦ The maximum inductive load is 2 mH.</li> </ul> </li> <li>• Test pulses are used to detect short circuits and interruptions of wires. The switch off test pulse interval is 5.5 ms, the maximum test pulse duration is 120 μs.</li> </ul>
Status outputs	Maximum output current per channel: 100 mA, nominal voltage 24 Vdc
Probability of a dangerous failure per hour (PFHd)	6.85E-9
Mean Time to Dangerous Failure (MTTFd) in years	382
Connection to PC	USB 2.0 or greater, no isolation. Maximum cable length: 3 m (9.84 ft)
Connection to expansion modules	5-way backplane expansion
Weight	0.12 kg (4.2 oz)
Slot for memory card	Yes

**NOTE:** For the characteristics common to all modules, refer to General Characteristics, page 24.

**⚠ DANGER**

**FIRE HAZARD**

Use only the correct wire sizes for the maximum current capacity of the I/O channels and power supplies.

**Failure to follow these instructions will result in death or serious injury.**

**⚠ WARNING**

**UNINTENDED EQUIPMENT OPERATION**

Do not exceed any of the rated values specified in the characteristics tables.

**Failure to follow these instructions can result in death, serious injury, or equipment damage.**

# XPSMCMC10804(G) Modular Safety Controller

## Controller and Functional Description

### Presentation

XPSMCMC10804(G) is a Modular Safety Controller providing eight safety-related inputs and four solid-state safety-related outputs, which can be used as four single or two dual (Output Signal Switching Device, OSSD), and can be configured using SoSafe Configurable. In addition, the Modular Safety Controller can be combined with a number of expansion modules through the backplane expansion bus.

For more information refer to the *Modular Safety Controller Library and Programming Guide*.

**Configuration of the controller :** To connect to a USB 2.0 or greater USB port of a PC, the XPSMCMC10804(G) Modular Safety Controller requires:

- a USB/Mini B configuration cable, for firmware versions less than v8.0.0
- a USB/USB-C configuration cable, for firmware version v8.0.0 and greater

The XPSMCMC10804(G) requires SoSafe Configurable to configure the controller and system.

**Optional memory card:** An optional backup memory card can be installed in the XPSMCMC10804(G) Modular Safety Controller and used to store the configuration.

### Input **RESTART\_FBK (RST\_FBK)**

The *RESTART\_FBK (RST\_FBK)* signal input allows the XPSMCMC10804(G) controller to verify an EDM (External Device Monitoring) feedback signal (series of contacts) from external contactors, and to monitor manual/automatic operation.

**⚠ WARNING**

**UNINTENDED EQUIPMENT OPERATION**

- The *RESTART* command device must be installed outside the zone of operation in a position where the zone of operation and the entire work area concerned are clearly visible.
- It must not be possible to operate the *RESTART* command device from inside the zone of operation.

**Failure to follow these instructions can result in death, serious injury, or equipment damage.**

Operation mode	EDM	Restart_fbk
Automatic	With K1_K2 control	
	Without K1_K2 control	
Manual	With K1_K2 control	
	Without K1_K2 control	

## Output STATUS (SIL 1/PL c in Accordance with Standard EN 61508:2010)

The status outputs are configurable digital diagnostic outputs that indicate the status of safety-related inputs and/or outputs.

Four status outputs are available on the XPSMCMC10804(G) Modular Safety Controller. The status outputs are shared with the feedback/restart inputs of the OSSDs. To use the status outputs, the corresponding OSSD must be used with automatic reset without external feedback monitoring. For example, to use the *STATUS1* output (Terminal 7), you must program *OSSD1* (by means of SoSafe Configurable) with automatic reset without K feedback monitoring.

The status outputs are SIL 1/PL c outputs.

<b>⚠ WARNING</b>
<b>INSUFFICIENT SAFETY-RELATED FUNCTIONS</b>
Do not use status outputs for safety-related purposes greater than SIL 1/PL c (EN 61508:2010).
<b>Failure to follow these instructions can result in death, serious injury, or equipment damage.</b>

## Output TEST

The **TEST** outputs are related to be used with the input circuits of the Modular Safety Controller.

The **TEST** outputs must be used to monitor the presence of cross circuits or short-circuits on the inputs. Connecting the test outputs helps to reach PL e in accordance with ISO 13849-1 and SILCL 3 in accordance with IEC 62061.

**NOTE:** These safety levels can also be obtained by applying other means of fault exclusion as described in ISO 13849-2.

**NOTE:** The test outputs of a specific module can only be linked to the inputs of the same module.

The maximum number of controllable inputs for each test output terminal is:

- Four inputs (parallel connection) for XPSMCMC10804(G), XPSMCMX0802(G), XPSMCMX0804(G), XPSMCMX0800(G), XPSMCMX1200MT(G), XPSMCMX1600(G).

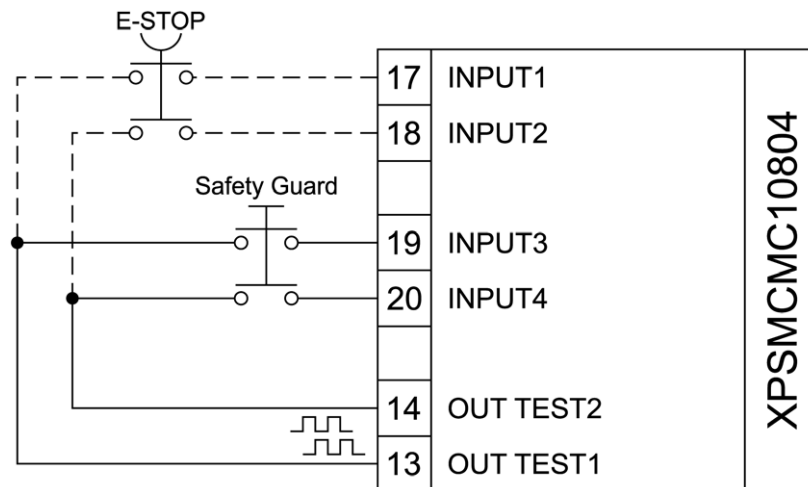

Type C, class 3 according to "ZVEI CB24I Ed.2" with a maximum test pulse duration of 120 μs.

## Solid-State Safety-Related Output (OSSD)

### ⚠ WARNING

#### UNINTENDED EQUIPMENT OPERATION

Do not connect any equipment to an OSSD unless the OSSD is appropriately configured with SoSafe Configurable.

**Failure to follow these instructions can result in death, serious injury, or equipment damage.**

The four OSSD safety-related outputs of the Modular Safety Controller are short-circuit protected.

The outputs are able to supply:

- In the ON condition:  $U_v - 0.6 V \dots U_v$   
where  $U_v = 24 V_{dc} \pm 20\%$
- In the OFF condition:  $0 \dots 2 V_{rms}$  (root mean square)

The maximum load current of 400 mA (per OSSD). The minimum resistive load is 60  $\Omega$ .

The maximum capacitive load is 0.68  $\mu F$ .

The maximum inductive load is 2 mH.

Type C, class 3 according to "ZVEI CB24I Ed.2" with a maximum test pulse duration of 120  $\mu s$ .

Different output configurations (configurable with SoSafe Configurable) can be set:

- 4 single channels (1 safety-related output per channel with its corresponding feedback input).
- 2 dual channels (2 safety-related outputs with their corresponding feedback input per channel).
- 1 dual channel and 2 single channels.

The following table indicates how each OSSD output can be configured:

Automatic	The output is activated according to the configurations set by the SoSafe Configurable software, only if the corresponding <i>RESTART</i> input is connected to $U_v$ ( $24 V_{dc} \pm 20\%$ ).
Manual	The output is activated according to the configurations set by the SoSafe Configurable software, only if the level at the corresponding <i>RESTART</i> input changes from 0 Vdc to $U_v$ ( $24 V_{dc} \pm 20\%$ ).
Monitored	The output is activated according to the configurations set by the SoSafe Configurable software, only if the level at the corresponding <i>RESTART</i> input changes from 0 Vdc to $U_v$ ( $24 V_{dc} \pm 20\%$ ) and back to 0 Vdc.

## Connector Designations and Sample Wiring Diagrams

### Modular Safety Controller Connector Designations

Terminal	Signal	LED	Type	Description	Operation
1	24 VDC	PWR	-	24 Vdc power supply	-
2	N.C.	-	-	-	-
3	N.C.	-	-	-	-
4	0 VDC	PWR	-	0 Vdc power supply	-

Terminal	Signal	LED	Type	Description	Operation
5	OSSD1	OSSD 1	Output	Safety-related output 1	PNP active at $U_v$ (24 Vdc $\pm$ 20%).
6	OSSD2	OSSD 2	Output	Safety-related output 2	
7	RESTART_FBK1/ STATUS1	RST_FBK/ STATUS 1	Input/ output	Feedback/Restart 1 for OSSD1	Input type 3 according to EN 61131-2. Maximum resistance 1.2 k $\Omega$ .
				Configurable output 1 for OSSD1	Configurable output (SIL 1/PL c in accordance with EN 61508:2010)
8	RESTART_FBK2/ STATUS2	RST_FBK/ STATUS 2	Input/ output	Feedback/Restart 2 for OSSD2	Input type 3 according to EN 61131-2. Maximum resistance 1.2 k $\Omega$ .
				Configurable output 2 for OSSD2	Configurable output (SIL 1/PL c in accordance with EN 61508:2010)
9	OSSD3	OSSD 3	Output	Safety-related output 3	PNP active at $U_v$ (24 Vdc $\pm$ 20%).
10	OSSD4	OSSD 4	Output	Safety-related output 4	
11	RESTART_FBK3/ STATUS3	RST_FBK/ STATUS 3	Input/ output	Feedback/Restart 3 for OSSD3	Input type 3 according to EN 61131-2. Maximum resistance 1.2 k $\Omega$ .
				Configurable output 3 for OSSD3	Configurable output (SIL 1/PL c in accordance with EN 61508:2010)
12	RESTART_FBK4/ STATUS4	RST_FBK/ STATUS 4	Input/ output	Feedback/Restart 4 for OSSD2	Input type 3 according to EN 61131-2. Maximum resistance 1.2 k $\Omega$ .
				Configurable output 4 for OSSD2	Configurable output (SIL 1/PL c in accordance with EN 61508:2010)
13	OUT_TEST1	-	Output	Test output for detection of short circuits/cross circuits in input circuits	PNP active at 24 Vdc.
14	OUT_TEST2	-			
15	OUT_TEST3	-			
16	OUT_TEST4	-			
17	INPUT1	IN 1	Input	Safety-related input 1	Input type 3 according to EN 61131-2. Maximum resistance 1.2 k $\Omega$ .
18	INPUT2	IN 2		Safety-related input 2	
19	INPUT3	IN 3		Safety-related input 3	
20	INPUT4	IN 4		Safety-related input 4	
21	INPUT5	IN 5		Safety-related input 5	
22	INPUT6	IN 6		Safety-related input 6	
23	INPUT7	IN 7		Safety-related input 7	
24	INPUT8	IN 8		Safety-related input 8	

## ▲ WARNING

### UNINTENDED EQUIPMENT OPERATION

Do not connect wires to unused terminals and/or terminals indicated as "No Connection (N.C.)" or Not Connected.

**Failure to follow these instructions can result in death, serious injury, or equipment damage.**

**NOTE:** The status outputs signal are shared with the feedback/restart inputs of the OSSDs. To use them, the corresponding OSSD must be used with automatic reset without external feedback monitoring.

For example, to use the *RESTART\_FBK1/STATUS1* as *STATUS* (Terminal7), you must configure *OSSD1* (by means of SoSafe Configurable) with automatic reset without K feedback monitoring.

## Modular Safety Controller Sample Wiring Diagram

The following internal wiring diagram depicts the difference between single and dual channel logic within the module:

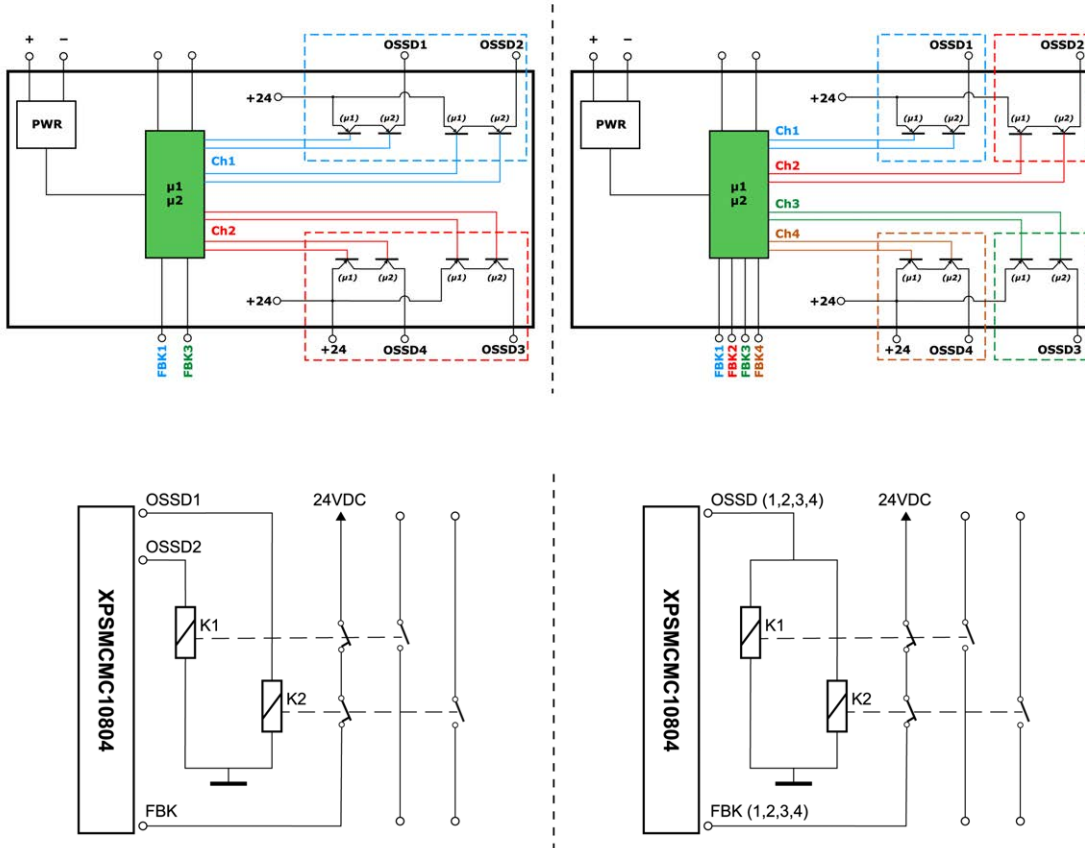

Dual channel OSSD configuration with 2 dual channel outputs, safety category SIL3/PL e: EN 61508:2010.

Single channel OSSD configuration with 4 single outputs, safety category SIL3/PL e: EN 61508:2010.

Category 3 wiring for XPSMCMC10804:

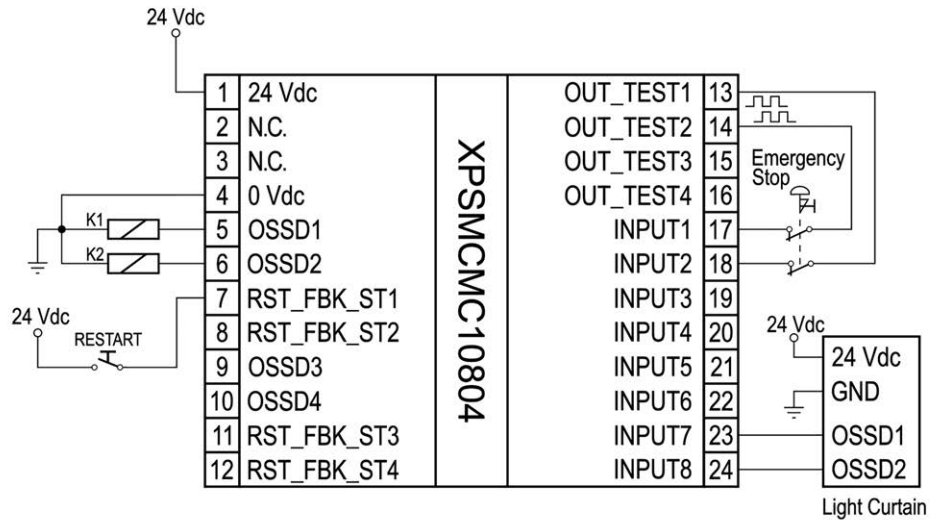

**NOTE:** Best practice dictates the use of fusing on the incoming 24 Vdc power, and sized appropriately for the requirements of the module.

**⚠ WARNING**

**UNINTENDED EQUIPMENT OPERATION**

Do not connect wires to unused terminals and/or terminals indicated as "No Connection (N.C.)" or Not Connected.

**Failure to follow these instructions can result in death, serious injury, or equipment damage.**

Category 4 wiring for XPSMCMC10804(G) with feedback of the contactors K1 and K2:

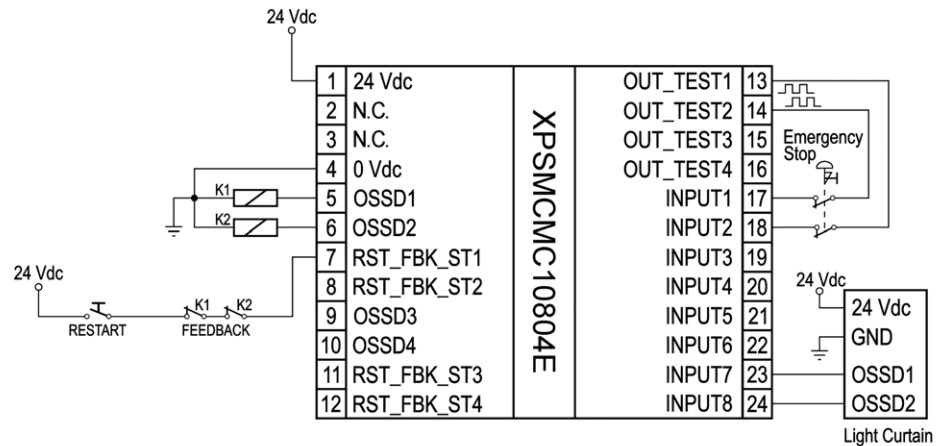

**NOTE:** Best practice dictates the use of fusing on the incoming 24 Vdc power, and sized appropriately for the requirements of the module.

**⚠ WARNING**

**UNINTENDED EQUIPMENT OPERATION**

Do not connect wires to unused terminals and/or terminals indicated as "No Connection (N.C.)" or Not Connected.

**Failure to follow these instructions can result in death, serious injury, or equipment damage.**

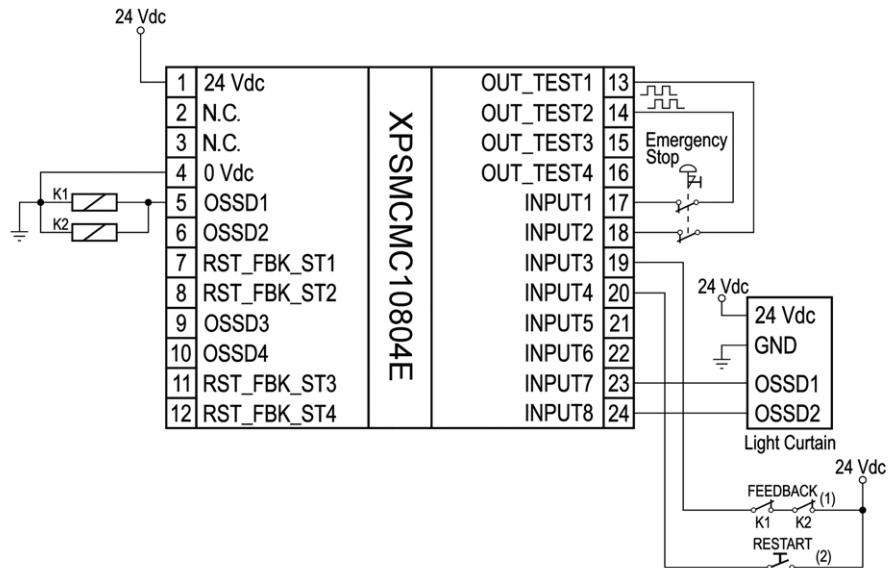

(1) Contacts connected to the *OSSD EDM* functional block

(2) Contacts connected to the *USER RESTART MANUAL*, *USER RESTART MONITORED* or *MACRO RESTART MANUAL*, *MACRO RESTART MONITORED* function block.

**NOTE:** Best practice dictates the use of fusing on the incoming 24 Vdc power, and sized appropriately for the requirements of the module.

## ⚠ WARNING

### UNINTENDED EQUIPMENT OPERATION

Do not connect wires to unused terminals and/or terminals indicated as "No Connection (N.C.)" or Not Connected.

**Failure to follow these instructions can result in death, serious injury, or equipment damage.**

# LED Indicators

## Front-Face View

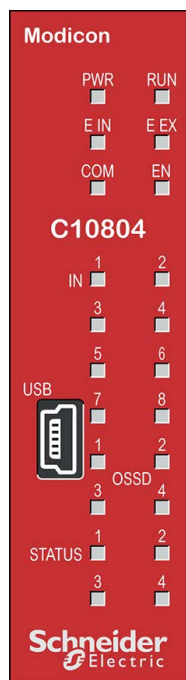

For controller with firmware version less than 8.0.0

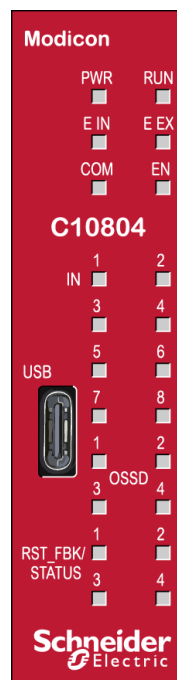

For controller with firmware version 8.0.0 or greater

## Operation States

The following table describes the indication of operation states of the XPSMCMC10804(G) by means of the LEDs. The description assumes that the power LED (**PWR**) is ON:

RUN green	E IN red	E EX red	COM orange	EN blue	IN 1...8 yellow	OSSD 1...4 red/ green/ yellow	RST_FBK/ STATUS 1...4 yellow	Meaning
ON	ON	ON	ON	ON	ON	Red	ON	Power on - initial test
OFF	OFF	OFF	ON (maximum 1 s)	ON (maximum 1 s)	OFF	Red	OFF	Memory card recognized
OFF	OFF	OFF	5 flashes	5 flashes	OFF	Red	OFF	Writing/loading project to/ from memory card
ON	OFF	OFF	ON = connected OFF = not connected	ON	Reflect input state	Red = output OFF  Green = output ON  Steady yellow = waiting for restart  Flashing yellow = no feedback	Reflect status output state	Normal operation

## Troubleshooting

The following table describes the indication of detected errors of the XPSMCMC10804(G) by means of the LEDs. The description assumes that the power LED (**PWR**) is ON:

Detected error	<b>RUN</b> green	<b>E IN</b> red	<b>E EX</b> red	<b>COM</b> orange	<b>EN</b> blue	<b>IN 1...8</b> yellow	<b>OSSD 1...4</b> red/ green/ yellow	<b>RST_ FBK/ STATUS 1...4</b> yellow	Solution
Internal error detected	OFF	2 or 3 flashes periodically	OFF	OFF	OFF	OFF	Red	OFF	Product non serviceable <sup>(1)</sup> .
Configuration error detected	OFF	OFF	OFF	Flashes slowly	OFF	OFF	Red	OFF	Download the configuration to the controller <sup>(1)</sup> .
Expansion module or node number not correct	OFF	OFF	OFF	Flashes quickly	OFF	OFF	Red	OFF	Verify the hardware configuration and the terminal 2 and 3 of each expansion module.
Expansion module not found or not ready	Flashes quickly	OFF	OFF	Flashes quickly	OFF	OFF	Red	OFF	Verify the hardware configuration and the state of each expansion module.
External wiring error detected	ON	OFF	ON	ON = connected OFF = not connected	ON	Flashing = input with error	Red = output OFF Flashing Yellow = no feedback	Reflect status output state	Verify all I/O connections.
OSSD output error detected	OFF	4 flashes periodically repeated	OFF	OFF	OFF	OFF	4 flashes (only corresponding LED)	OFF	Verify correct wiring of the safety-related outputs (OSSD) <sup>(1)</sup> .
Overload on OSSD / OSSD load connected to 24 Vdc detected	ON	OFF	ON	OFF	ON	Input state	Flashing red (only corresponding LED)	Reflect status output state	Verify correct wiring of the safety-related outputs (OSSD) <sup>(1)</sup> .
Error in communication with expansion module detected	OFF	5 flashes periodically repeated	OFF	OFF	OFF	OFF	OFF	OFF	Restart the system <sup>(1)</sup> .
Expansion module error detected	OFF	ON	OFF	OFF	OFF	OFF	OFF	OFF	Restart the system. Identify the expansion module affected by this condition and consult its user guide.
Memory card error detected.	OFF	6 flashes periodically repeated	OFF	6 flashes	OFF	OFF	OFF	OFF	Replace the memory card, page 153.

Detected error	RUN green	E IN red	E EX red	COM orange	EN blue	IN 1...8 yellow	OSSD 1...4 red/ green/ yellow	RST_ FBK/ STATUS 1...4 yellow	Solution
Short circuit or overload detected on status output	ON	OFF	ON	OFF	Input state	ON	Output state	Flashing	Verify correct wiring of STATUS output <sup>(1)</sup> .

(1) If the condition persists, contact your local Schneider Electric representative.

## Controller Characteristics

### Presentation

Controller-specific characteristics	
Description	Electronic housing maximum 24-poles, with locking latch mounting
Mounting	DIN rail mounting with locking latch
Maximum number of inputs of a complete MCM system	128
Maximum number of OSSD safety-related outputs of a complete MCM system	32
Maximum number of expansion modules (excluding XPSMCMER00••(G))	14
Maximum number of expansion modules of the same reference (excluding XPSMCMER00••(G))	4
Safety-related input (number / description)	8 / Input type 3 according to EN 61131-2. Maximum resistance 1.2 kΩ.
Restart Input (optional to status outputs) (number / description)	4 / EDM (External Device Monitoring) type 3 according to EN 61131-2. Maximum resistance 1.2 kΩ. Possible automatic restart function or manual operation with restart pushbutton.
Status outputs (optional to restart input) (number / description)	4 / SIL 1/PL c in accordance with standard EN 61508:2010. Maximum current per output: 100 mA, nominal voltage 24 Vdc.
Test output (number / description)	4 / For cross circuit/short circuit monitoring, maximum current 100 mA, nominal voltage 24 Vdc.
Controller to controller by Network function	Maximum 10 Modular Safety Controllers with distance of up to 100 m (328 ft) between each controller.
Solid-state safety-related output (OSSD)	4 / solid-state safety-related outputs PNP active high <ul style="list-style-type: none"> <li>• Interface type C class 3 (ZVEI CB24I Ed.2)</li> <li>• The outputs are able to supply:                             <ul style="list-style-type: none"> <li>◦ In the ON condition: <math>U_v - 0.6 V \dots U_v</math> where <math>U_v = 24 V_{dc} \pm 20\%</math></li> <li>◦ In the OFF condition: <math>0 \dots 2 V_{rms}</math> (root mean square)</li> </ul> </li> <li>• The maximum load current of 400 mA (per OSSD) corresponds to a minimum resistive load of 60 Ω.                             <ul style="list-style-type: none"> <li>◦ The maximum capacitive load is 0.68µF.</li> <li>◦ The maximum inductive load is 2 mH.</li> </ul> </li> <li>• Test pulses are used to detect short circuits and interruptions of wire continuity. The switch-off test pulse interval is every 600 ms, the maximum test pulse duration is 120 µs.</li> </ul>
Probability of a Dangerous Failure per Hour (PFHd)	1.41E-08

Controller-specific characteristics	
Mean Time to Dangerous Failure (MTTFd) in years	157
Connection to PC	USB 2.0 or greater, no isolation. Maximum cable length: 3 m (9.84 ft)
Connection to expansion modules	5-way backplane expansion
Weight	0.155 kg (5.46 oz)
Slot for memory card	Yes

**NOTE:** For the characteristics common to all modules, refer to General Characteristics, page 24.

## ⚠ DANGER

### FIRE HAZARD

Use only the correct wire sizes for the maximum current capacity of the I/O channels and power supplies.

**Failure to follow these instructions will result in death or serious injury.**

## ⚠ WARNING

### UNINTENDED EQUIPMENT OPERATION

Do not exceed any of the rated values specified in the characteristics tables.

**Failure to follow these instructions can result in death, serious injury, or equipment damage.**

To achieve Performance Level PL e, according to standard EN 13849-1, the OSSD safety-related outputs must be independent.

Reduce Common Cause Failures (CCF) of OSSD safety-related outputs by separating cable paths (refer to ISO 13849-2 for event exclusion).

## ⚠ WARNING

### UNINTENDED EQUIPMENT OPERATION

Run single channel, dual wiring in separate cabling.

**Failure to follow these instructions can result in death, serious injury, or equipment damage.**

# XPSMCMC10804E(G) Modular Safety Controller with Communication Embedded

## Controller and Functional Description

### Presentation

XPSMCMC10804E(G) is a Modular Safety Controller providing eight safety-related inputs and four solid-state safety-related outputs, which can be used as four single or two dual OSSDs (Output Signal Switching Devices), and can be configured using SoSafe Configurable. Industrial Ethernet based communication is embedded (Multi-protocol EtherCAT, Ethernet/IP, Modbus TCP and

PROFINET). In addition, the Modular Safety Controller can be combined with a number of expansion modules through the backplane expansion bus.

**Configuration of the controller:** The XPSMCMC10804E(G) Modular Safety Controller requires the SoSafe Configurable software version 1.9.0 or greater for configuration of the controller and the system. The controller has a USB 2.0 port with a USB-C socket for connection to the PC with the configuration software. The PC must provide a USB 2.0 port or greater. You need a matching cable to connect PC and controller.

**Optional memory card:** An optional backup memory card can be installed in the XPSMCMC10804E(G) Modular Safety Controller and used to store the software configuration parameters.

**NOTE:** The XPSMCMC10804E(G) Modular Safety Controller must be the module furthest to the right in an installation of other modules, due to the position of the bus connection. If this is not suitable, use the TBUS adapter available from Phoenix Contact, part number 2201756, ME 22.5 TBUS ADAPTER KMGY, to connect expansion modules to the right of the controller.

## Safety-Related Inputs

The XPSMCMC10804E(G) Modular Safety Controller provides eight digital inputs for connection of safety-related input devices such as emergency stop push-buttons, magnetic switches, light curtains.

### Input *RESTART\_FBK (RST\_FBK)*

The *RESTART\_FBK (RST\_FBK)* signal input allows the XPSMCMC10804E(G) controller to verify an EDM (External Device Monitoring) feedback signal (series of contacts) from external contactors, and to monitor manual/automatic operation.

<b>⚠ WARNING</b>		
<b>UNINTENDED EQUIPMENT OPERATION</b>		
<ul style="list-style-type: none"> <li>• The <i>RESTART</i> command device must be installed outside the zone of operation in a position where the zone of operation and the entire work area concerned are clearly visible.</li> <li>• It must not be possible to operate the <i>RESTART</i> command device from inside the zone of operation.</li> </ul>		
<b>Failure to follow these instructions can result in death, serious injury, or equipment damage.</b>		

Operation mode	EDM	Restart_fbk
Automatic	With K1_K2 control	
	Without K1_K2 control	
Manual	With K1_K2 control	
	Without K1_K2 control	

## Output STATUS (SIL 1/PL c in Accordance with Standard IEC 61508:2010)

The status outputs are configurable digital diagnostic outputs that indicate the status of safety-related inputs and/or outputs.

Four status outputs are available on the XPSMCMC10804E(G) Modular Safety Controller. The status outputs are shared with the feedback/restart inputs of the OSSDs. To use the status outputs, the corresponding OSSD must be used with automatic reset without external feedback monitoring. For example, to use the *RESTART\_FBK1/STATUS1* as *STATUS* (Terminal 7), you must program *OSSD1* (by means of SoSafe Configurable) with automatic reset without K feedback monitoring.

The status outputs are SIL 1/PL c outputs.

<b>⚠ WARNING</b>
<b>INSUFFICIENT SAFETY-RELATED FUNCTIONS</b>
Do not use status outputs for safety-related purposes greater than SIL 1/PL c (IEC 61508:2010).
<b>Failure to follow these instructions can result in death, serious injury, or equipment damage.</b>

## Output TEST

The *TEST* outputs are to be used with the input circuits of the Modular Safety Controller.

The *TEST* outputs must be used to monitor the presence of cross circuits or short-circuits on the inputs. Connecting the test outputs helps to reach PL e in accordance with ISO 13849-1 and maximum SIL 3 in accordance with IEC 62061.

**NOTE:** These safety levels can also be obtained by applying other means of fault exclusion as described in ISO 13849-2.

**NOTE:** The test outputs of a specific module can only be linked to the inputs of the same module.

Each test output is able to drive a maximum of four inputs in parallel.

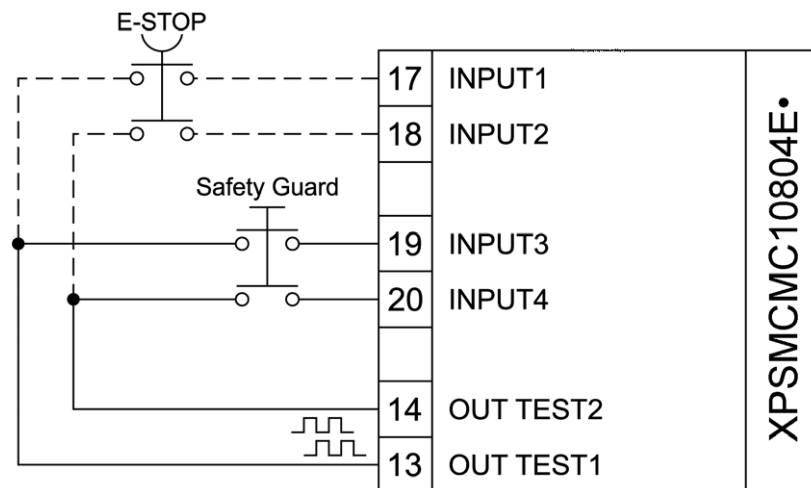

Interface Type C, class 3 according to "ZVEI CB241 Ed.2" with a maximum test pulse duration of 120 μs.

## Solid-State Safety-Related Output (OSSD)

**⚠ WARNING**

**UNINTENDED EQUIPMENT OPERATION**

Do not connect any equipment to an OSSD unless the OSSD is appropriately configured with SoSafe Configurable.

**Failure to follow these instructions can result in death, serious injury, or equipment damage.**

The four OSSD safety-related outputs are short-circuit protected.

The outputs are able to supply:

- In the ON condition:  $U_v - 0.75 V \dots U_v$   
where  $U_v = 24 V_{dc} \pm 20\%$
- In the OFF condition:  $0 \dots 2 V_{rms}$  (root mean square)

The maximum load current of 400 mA (per OSSD). The minimum resistive load is 60 Ω.

The maximum capacitive load is 0.82 μF.

The maximum inductive load is 2 mH.

Interface Type C, class 3 according to "ZVEI CB24I Ed.2" with a maximum test pulse duration of 120 μs.

Different output configurations (configurable with SoSafe Configurable) can be set:

- 4 single channels (1 safety-related output per channel with its corresponding feedback input).
- 2 dual channels (2 safety-related outputs with their corresponding feedback input per channel).
- 1 dual channel and 2 single channels.

The following table indicates how each OSSD output can be configured:

Automatic	The output is activated according to the configurations set by the SoSafe Configurable software, only if the corresponding <i>RESTART</i> input is connected to $U_v$ ( $24 V_{dc} \pm 20\%$ ).
Manual	The output is activated according to the configurations set by the SoSafe Configurable software, only if the level at the corresponding <i>RESTART</i> input changes from 0 Vdc to $U_v$ ( $24 V_{dc} \pm 20\%$ ).
Monitored	The output is activated according to the configurations set by the SoSafe Configurable software, only if the level at the corresponding <i>RESTART</i> input changes from 0 Vdc to $U_v$ ( $24 V_{dc} \pm 20\%$ ) and back to 0 Vdc.

# Connector Designations, Terminals and Dimensions

## Terminals

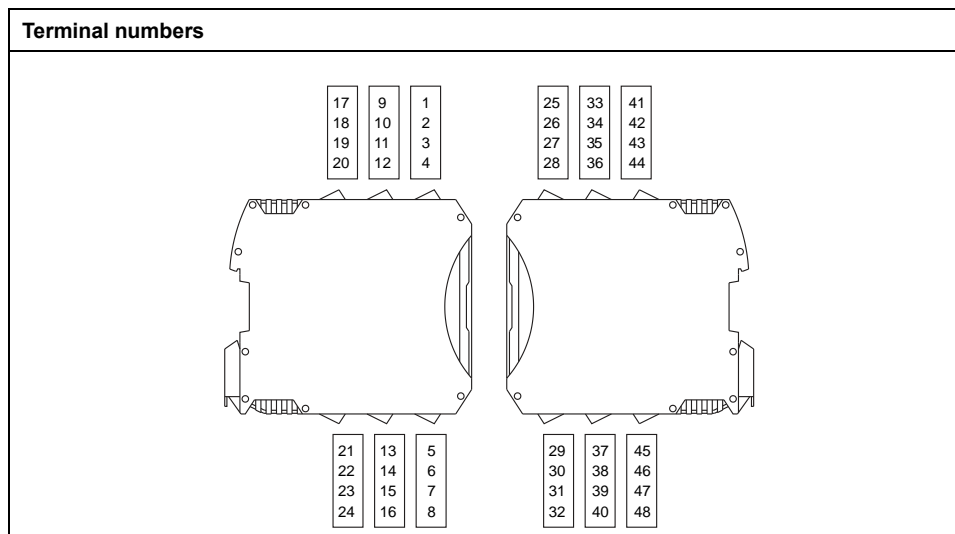

## Modular Safety Controller Connector Designations

Terminal	Signal	LED	Type	Description	Operation
1	24 VDC	PWR	-	24 Vdc power supply	-
2	N.C.	-	-	-	-
3	N.C.	-	-	-	-
4	0 VDC	PWR	-	0 Vdc power supply	-
5	OSSD1	OSSD 1	Output	Safety-related output 1	PNP active at Uv (24 Vdc ± 20%).
6	OSSD2	OSSD 2	Output	Safety-related output 2	
7	RESTART_FBK1/ STATUS1	RST_FBK/ STATUS 1	Input/ output	Feedback/Restart 1 for OSSD1	Input type 3 according to EN 61131-2. Maximum resistance 1.2 kΩ.
				Configurable output 1 for OSSD1	Configurable output (SIL 1/PL c in accordance with EN 61508:2010)
8	RESTART_FBK2/ STATUS2	RST_FBK/ STATUS 2	Input/ output	Feedback/Restart 2 for OSSD2	Input type 3 according to EN 61131-2. Maximum resistance 1.2 kΩ.
				Configurable output 2 for OSSD2	Configurable output (SIL 1/PL c in accordance with EN 61508:2010)
9	OSSD3	OSSD 3	Output	Safety-related output 3	PNP active at Uv (24 Vdc ± 20%).
10	OSSD4	OSSD 4	Output	Safety-related output 4	
11	RESTART_FBK3/ STATUS3	RST_FBK/ STATUS 3	Input/ output	Feedback/Restart 3 for OSSD3	Input type 3 according to EN 61131-2. Maximum resistance 1.2 kΩ.
				Configurable output 3 for OSSD3	Configurable output (SIL 1/PL c in accordance with EN 61508:2010)
12	RESTART_FBK4/ STATUS4	RST_FBK/ STATUS 4	Input/ output	Feedback/Restart 4 for OSSD2	Input type 3 according to EN 61131-2. Maximum resistance 1.2 kΩ.
				Configurable output 4 for OSSD2	Configurable output (SIL 1/PL c in accordance with EN 61508:2010)

Terminal	Signal	LED	Type	Description	Operation
13	OUT_TEST1	-	Output	Test output for detection of short circuits/cross circuits in input circuits	PNP active at 24 Vdc.
14	OUT_TEST2	-			
15	OUT_TEST3	-			
16	OUT_TEST4	-			
17	INPUT1	IN 1	Input	Safety-related input 1	Input type 3 according to EN 61131-2. Maximum resistance 1.2 kΩ.
18	INPUT2	IN 2		Safety-related input 2	
19	INPUT3	IN 3		Safety-related input 3	
20	INPUT4	IN 4		Safety-related input 4	
21	INPUT5	IN 5		Safety-related input 5	
22	INPUT6	IN 6		Safety-related input 6	
23	INPUT7	IN 7		Safety-related input 7	
24	INPUT8	IN 8		Safety-related input 8	

## ▲ WARNING

### UNINTENDED EQUIPMENT OPERATION

Do not connect wires to unused terminals and/or terminals indicated as "No Connection (N.C.)" or Not Connected.

**Failure to follow these instructions can result in death, serious injury, or equipment damage.**

**NOTE:** The status outputs signal are shared with the feedback/restart inputs of the OSSDs. To use them, the corresponding OSSD must be used with automatic reset without external feedback monitoring.

For example, to use the *RESTART\_FBK1/STATUS1* as *STATUS* output (Terminal7), you must program *OSSD1* (by means of SoSafe Configurable) with automatic reset without K feedback monitoring.

## Wiring Example

Category 4 wiring for XPSMCMC10804E(G) with feedback of the contactors K1 and K2:

- With use of the dedicated feedback input of the (double) OSSD

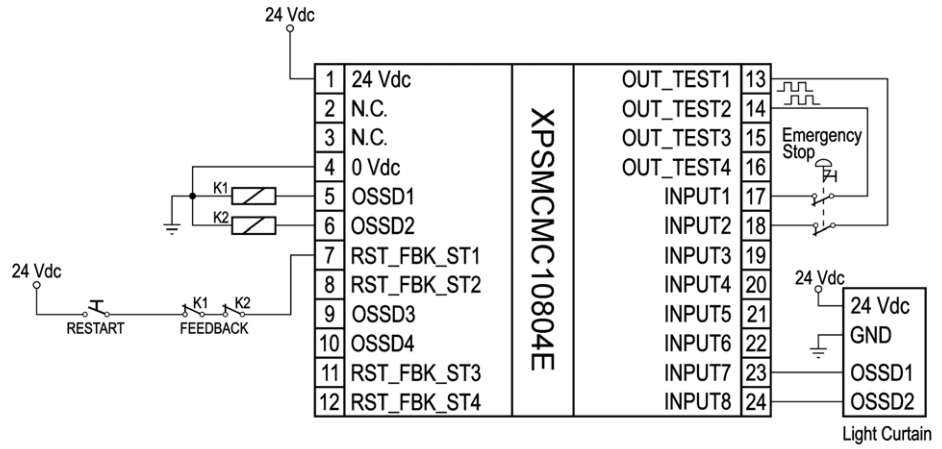

**NOTE:** Best practice dictates the use of fusing on the incoming 24 Vdc power, and sized appropriately for the requirements of the module.

**⚠ WARNING**

**UNINTENDED EQUIPMENT OPERATION**

Do not connect wires to unused terminals and/or terminals indicated as "No Connection (N.C.)" or Not Connected.

**Failure to follow these instructions can result in death, serious injury, or equipment damage.**

- With single OSSD and use of general inputs and dedicated function blocks for EDM and restart configuration

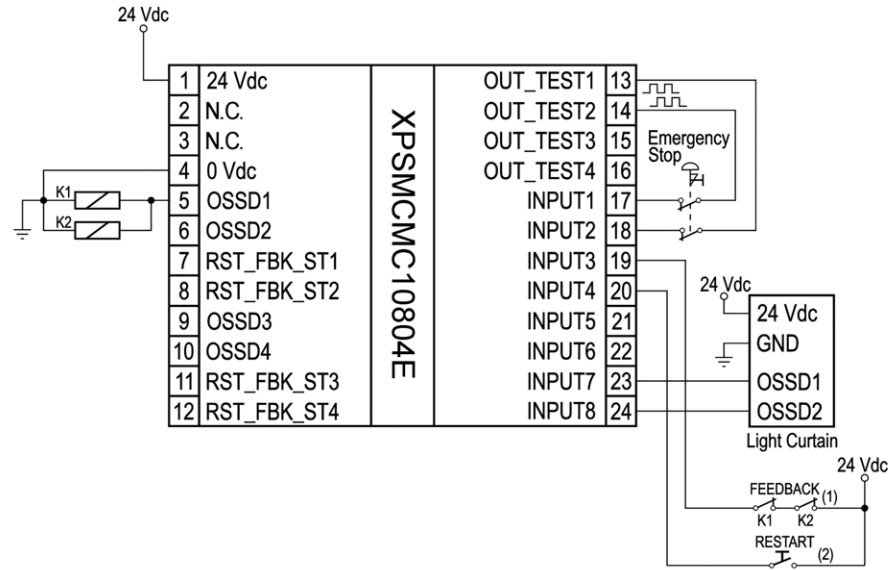

(1) Inputs connected to the *OSSD EDM* functional block

(2) Inputs connected to the *USER RESTART MANUAL, USER RESTART MONITORED or MACRO RESTART MANUAL, MACRO RESTART MONITORED* function block.

**NOTE:** Best practice dictates the use of fusing on the incoming 24 Vdc power, and sized appropriately for the requirements of the module.

⚠ WARNING
UNINTENDED EQUIPMENT OPERATION
Do not connect wires to unused terminals and/or terminals indicated as "No Connection (N.C.)" or Not Connected.
Failure to follow these instructions can result in death, serious injury, or equipment damage.

To achieve Performance Level PL e, according to standard EN 13849-1, the OSSD safety-related outputs must be independent.

Reduce Common Cause Failures (CCF) of OSSD safety-related outputs by separating cable paths (refer to ISO 13849-2 for event exclusion).

⚠ WARNING
UNINTENDED EQUIPMENT OPERATION
Run single channel, dual wiring in separate cabling.
Failure to follow these instructions can result in death, serious injury, or equipment damage.

## Dimensions

Refer to Dimensions of the XPSMCMC10804E(G) Controller, page 26.

## Embedded Communication Interface

The embedded communication interface supports four protocols (Modbus TCP, Ethernet IP, EtherCAT, and Profinet).

Selection of the protocol and setup of the fieldbus parameters can be done using SoSafe Configurable version 1.9.0 or greater. Refer to the *Modular Safety Controller, Software and Library Guide*, for details about the configuration software. Refer to the *Modular Safety Controller, Communication Guide* for details about the data mapping.

**NOTE:** In addition to the embedded communication interface, one fieldbus extension module can be used in the same application, but it must not use the same protocol. If two fieldbus interfaces are used, only the fieldbus input signals of the extension module are taken into account by the application, not those received by the embedded communication interface. The diagnostic output data will be the same within the limitations of the protocols used, refer to the *Modular Safety Controller, Communication Guide* for details.

## LED Indicators

### Front-Face View

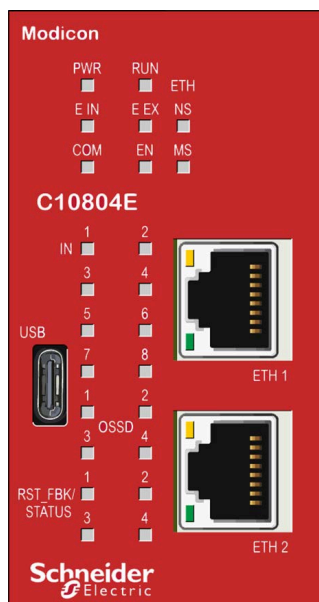

## Operation States

The following table describes the indication of operation states of the XPSMCMC10804E(G) by means of the LEDs. The description assumes that the power LED (**PWR**) is ON:

RUN green	E IN red	E EX red	COM orange	EN blue	IN 1...8 yellow	OSSD 1...4 red/ green/ yellow	RST_FBK/ STATUS 1...4 yellow	Meaning
ON	ON	ON	ON	ON	ON	Red	ON	Power on - initial test
OFF	OFF	OFF	ON (maximum 1 s)	ON (maximum 1 s)	OFF	Red	OFF	Memory card recognized
OFF	OFF	OFF	5 flashes	5 flashes	OFF	Red	OFF	Writing/loading project to/ from memory card

<b>RUN</b> green	<b>E IN</b> red	<b>E EX</b> red	<b>COM</b> orange	<b>EN</b> blue	<b>IN 1...8</b> yellow	<b>OSSD 1...4</b> red/ green/ yellow	<b>RST_FBK/ STATUS 1...4</b> yellow	<b>Meaning</b>
OFF	OFF	OFF	ON	OFF	OFF	Red	OFF	XPSMCMC10804E(G) connected to PC and stopped
OFF	OFF	OFF	flashes quickly alternately to <b>EN</b>	flashes quickly alternately to <b>COM</b>	OFF	Red	OFF	XPSMCMC10804E(G) new fieldbus protocol loading
ON	OFF	OFF	ON = connected OFF = not connected	ON	Reflect input state	Red = output OFF  Green = output ON  Steady yellow = waiting for restart  Flashing yellow = no feedback	Reflect status output state	Normal operation

For the LED **ETH MS** and **NS**, refer to Embedded Fieldbus LED Indicators, page 64

## Troubleshooting

The following table describes the indication of detected errors of the XPSMCMC10804E(G) by means of the LEDs. The description assumes that the power LED (**PWR**) is ON:

<b>Detected error</b>	<b>RUN</b> green	<b>E IN</b> red	<b>E EX</b> red	<b>COM</b> orange	<b>EN</b> blue	<b>IN 1...8</b> yellow	<b>OSSD 1...4</b> red/ green/ yellow	<b>RST_FBK/ STATUS 1...4</b> yellow	<b>Solution</b>
Internal error detected	OFF	2 or 3 flashes periodically	OFF	OFF	OFF	OFF	Red	OFF	Product non serviceable <sup>(1)</sup> .
Configuration error detected	OFF	OFF	OFF	Flashes slowly	OFF	OFF	Red	OFF	Download the configuration to the controller <sup>(1)</sup> .
Expansion module or node number not correct	OFF	OFF	OFF	Flashes quickly	OFF	OFF	Red	OFF	Verify the hardware configuration and the terminal 2 and 3 of each expansion module.
Expansion module not found or not ready	Flashes quickly	OFF	OFF	Flashes quickly	OFF	OFF	Red	OFF	Verify the hardware configuration and the state of each expansion module.
External wiring error detected	ON	OFF	ON	ON = connected OFF = not connected	ON	Flashing = input with error	Red = output OFF  Flashing Yellow = no feedback	Reflect status output state	Verify all I/O connections.

Detected error	RUN green	E IN red	E EX red	COM orange	EN blue	IN 1...8 yellow	OSSD 1...4 red/ green/ yellow	RST_ FBK/ STATUS 1...4 yellow	Solution
OSSD output error detected	OFF	4 flashes periodically repeated	OFF	OFF	OFF	OFF	4 flashes (only corresponding LED)	OFF	Verify correct wiring of the safety-related outputs (OSSD) <sup>(1)</sup> .
Overload on OSSD / OSSD load connected to 24 Vdc detected	ON	OFF	ON	OFF	ON	Input state	Flashing red (only corresponding LED)	Reflect status output state	Verify correct wiring of the safety-related outputs (OSSD) <sup>(1)</sup> .
Error in communication with expansion module detected	OFF	5 flashes periodically repeated	OFF	OFF	OFF	OFF	OFF	OFF	Restart the system <sup>(1)</sup> .
Expansion module error detected	OFF	ON	OFF	OFF	OFF	OFF	OFF	OFF	Restart the system. Identify the expansion module affected by this condition and consult its user guide.
Memory card error detected.	OFF	6 flashes periodically repeated	OFF	6 flashes	OFF	OFF	OFF	OFF	Replace the memory card, page 153.
Short circuit or overload detected on status output	ON	OFF	ON	OFF	Input state	ON	Output state	Flashing	Verify correct wiring of STATUS output <sup>(1)</sup> .
<b>(1)</b> If the condition persists, contact your local Schneider Electric representative.									

For the LED **ETH MS** and **NS**, refer to Embedded Fieldbus LED Indicators, page 64

## Embedded Fieldbus LED Indicators

The following tables describe the states of the LED indicators for the different communication protocols of XPSMCMC10804E(G).

**Ethernet/IP protocol**

LED	State	Indication
<b>ETH MS</b> (module status)	OFF	No power
	Green	Operating state Operational
	Flashes green	Not configured or scanner is idle
	Flashes green/red	Self-test
	Red	One or more unrecoverable errors detected
	Flashes red	One or more recoverable errors detected
<b>NS</b> (node status)	OFF	No power or no IP address
	Green	Online, connected. One or more connections established (CIP Class 1 or 3)
	Flashes green	Online, not connected
	Flashes green/red	Self-test
	Red	Duplicate IP address
	Flashes Red	Connection timeout, one or more connections timed out (CIP class 1 or 3)

**EtherCAT protocol**

LED	State	Indication
<b>ETH MS</b> (module status)	OFF	Operating state Init or no power
	Green	Operating state Operational
	Flashes green	Operating state Pre-Operational
	Flashes green once	Operating state Safe-Operational
<b>NS</b> (node status)	OFF	No error or no power
	Flashes red	Configuration not valid Operating state transition not possible
	Flashes red once	Local error detected
	Flashes red twice	Timeout EtherCAT SynchManager watchdog

**Modbus TCP protocol**

LED	State	Indication
<b>ETH MS</b> (module status)	OFF	No power or no IP address
	Green	Online, connected
	Flashes green	Online, Modbus/TCP task is not yet configured
	Fast flashes green	Modbus/TCP task is configured
<b>NS</b> (node status)	OFF	No error or no power
	Flashes red	One or more system errors detected
	Red	One or more communication errors detected

**Profinet protocol**

LED	State	Indication
ETH MS (module status)	OFF	No error or no power
	Red	Watchdog timeout or system error
	Flashes red	Communication established through the bus
NS (node status)	OFF	No error or no power
	Red	No configuration
	Flashes red	No data exchange

## Controller Characteristics

Controller and system specific characteristics	
Description	Electronic housing maximum 24-poles, with locking latch mounting
Mounting	DIN rail mounting with locking latch
Maximum number of inputs of a complete MCM system	128
Maximum number of OSSD safety-related outputs of a complete MCM system	32
Maximum number of expansion modules (excluding XPSMCMER00••(G))	14
Maximum number of expansion modules of the same reference (excluding XPSMCMER00••(G))	4
Safety-related input (number / description)	8 / Input type 3 according to IEC 61131-2. Maximum resistance 1.2 kΩ.
Restart input (optional to status output) (number / description)	4 / For start means and EDM (External Device Monitoring), inputs type 3 according to IEC 61131-2. Maximum resistance 1.2 kΩ. Possible automatic restart function or manual operation with restart pushbutton.
Status outputs (optional to restart input) (number / description)	4 / SIL 1/PL c in accordance with standard IEC 61508:2010. Maximum current per output: 100 mA, nominal voltage 24 Vdc.
Test output (number / description)	4 / For cross circuit/short circuit monitoring, maximum current 100 mA, nominal voltage 24 Vdc.
Controller to controller connection by use of the Network function	Maximum 10 Modular Safety Controllers with distance of up to 100 m (328 ft) between each controller.
Solid-state safety-related output (OSSD)	4 / solid-state safety-related outputs PNP active high <ul style="list-style-type: none"> <li>• Interface type C class 3 (ZVEI CB24I Ed.2)</li> <li>• The outputs are able to supply:                             <ul style="list-style-type: none"> <li>◦ In the ON condition: <math>U_v - 0.6 V \dots U_v</math> where <math>U_v = 24 V_{dc} \pm 20\%</math></li> <li>◦ In the OFF condition: <math>0 \dots 2 V_{rms}</math> (root mean square)</li> </ul> </li> <li>• The maximum load current of 400 mA (per OSSD) corresponds to a minimum resistive load of 60 Ω.                             <ul style="list-style-type: none"> <li>◦ The maximum capacitive load is 0.82 μF.</li> <li>◦ The maximum inductive load is 2 mH.</li> </ul> </li> <li>• Test pulses are used to detect short circuits and interruptions of wire continuity. The switch-off test pulse interval is every 600 ms, the maximum test pulse duration is 120 μs.</li> </ul>
Probability of a Dangerous Failure per Hour (PFHd)	2.89E-08 <sup>1</sup>
Mean Time to Dangerous Failure (MTTFd) in years	157

Controller and system specific characteristics	
Connection to PC	Controller side: USB 2.0, no isolation, USB type C socket. PC side: USB 2.0 or greater, maximum cable length: 3 m (9.84 ft).
Connection to expansion modules	5-way backplane expansion
Weight	0.225 kg (7.93 oz)
Slot for memory card	Yes
Supported fieldbus protocols	EtherNet/IP, MODBUS/TCP, PROFINET, EtherCAT
<b>(1)</b> If expansion modules are added to the configuration, the PFHd and MTTFd of the overall system is affected, refer to the SoSafe Configurable Project Report.	

**NOTE:** For the characteristics common to all modules, refer to General Characteristics, page 24.

**⚠ DANGER**

**FIRE HAZARD**

Use only the correct wire sizes for the maximum current capacity of the I/O channels and power supplies.

**Failure to follow these instructions will result in death or serious injury.**

**⚠ WARNING**

**UNINTENDED EQUIPMENT OPERATION**

Do not exceed any of the rated values specified in the characteristics tables.

**Failure to follow these instructions can result in death, serious injury, or equipment damage.**

To achieve Performance Level PL e, according to standard EN 13849-1, the OSSD safety-related outputs must be independent.

Reduce Common Cause Failures (CCF) of OSSD safety-related outputs by separating cable paths (refer to ISO 13849-2 for event exclusion).

**⚠ WARNING**

**UNINTENDED EQUIPMENT OPERATION**

Run single channel, dual wiring in separate cabling.

**Failure to follow these instructions can result in death, serious injury, or equipment damage.**

## XPSMCMAI0200(G) and XPSMCMAI0400(G) Analog Input Expansion Modules

### Module and Functional Description

#### Presentation

The XPSMCMAI0200(G) and XPSMCMAI0400(G) are analog input expansion modules. The XPSMCMAI0200(G) and XPSMCMAI0400(G) modules can only be configured with the XPSMCMC10804(G) or XPSMCMC10804E(G) Modular Safety Controller. The XPSMCMAI0200(G) provides up to two single or one dual

channel of safety-related analog input, while the XPSMCMAI0400(G) provides up to four single or two dual channel of safety-related analog inputs. Each of the channels is isolated and must be configured by SoSafe Configurable as voltage input or current input.

XPSMCMAI0200(G) and XPSMCMAI0400(G) can support a wide range of analog sensors (usually installed in a redundant configuration) such as:

- Temperature sensors
- Level sensors
- Load cell
- Position sensors

The expansion module supports two inputs `NODE_ADDR0` and `NODE_ADDR1` which are used to set a physical address to the module:

	<b>NODE_ADDR0 (Terminal 2)</b>	<b>NODE_ADDR1 (Terminal 3)</b>
NODE 0	0 (or not connected)	0 (or not connected)
NODE 1	24 Vdc	0 (or not connected)
NODE 2	0 (or not connected)	24 Vdc
NODE 3	24 Vdc	24 Vdc

**NOTE:** Do not use the same physical address for two units of the same module reference.  
**NOTE:** The LEDs **ADDR 1** and **ADDR 0** correspond to the `NODE_ADDR1` and `NODE_ADDR0` in this table respectively.  
**NOTE:** The node address wiring must match the configuration settings.

## Current Sensor Input/Output *IN\_S1/OUT\_S1,IN\_S2/OUT\_S2,IN\_S3/OUT\_S3,IN\_S4/OUT\_S4*

XPSMCMAI0200(G) can provide up to two and XPSMCMAI0400(G) can provide up to four external safety-related input/output for external current sensor. Each channel of XPSMCMAI0•00(G) modules can supply sensors with 24 Vdc at 30 mA (maximum load current).

The safety-related analog inputs are used to connect transducers with:

- 0...20 mA or 4...20 mA (selectable by SoSafe Configurable) safety-related analog current signals: *IN\_S1/OUT\_S1,IN\_S2/OUT\_S2,IN\_S3/OUT\_S3,IN\_S4/OUT\_S4*.

## Voltage Sensor Input/Output *NEG\_S1/POS\_S1,NEG\_S2/POS\_S2,NEG\_S3/POS\_S3,NEG\_S4/POS\_S4*

XPSMCMAI0200(G) can provide up to two and XPSMCMAI0400(G) can provide up to four external input/output for external voltage sensor. Each channel of XPSMCMAI0•00(G) modules can supply sensors with 24 Vdc at 30 mA.

The safety-related analog inputs are used to connect transducers with:

- 0...10 Vdc (selectable by SoSafe Configurable) safety-related analog voltage signals: *NEG\_S1/POS\_S1,NEG\_S2/POS\_S2,NEG\_S3/POS\_S3,NEG\_S4/POS\_S4*.

# Connector Designations and Sample Wiring Diagrams

## XPSMCMAl0200(G) Module Connector Designations

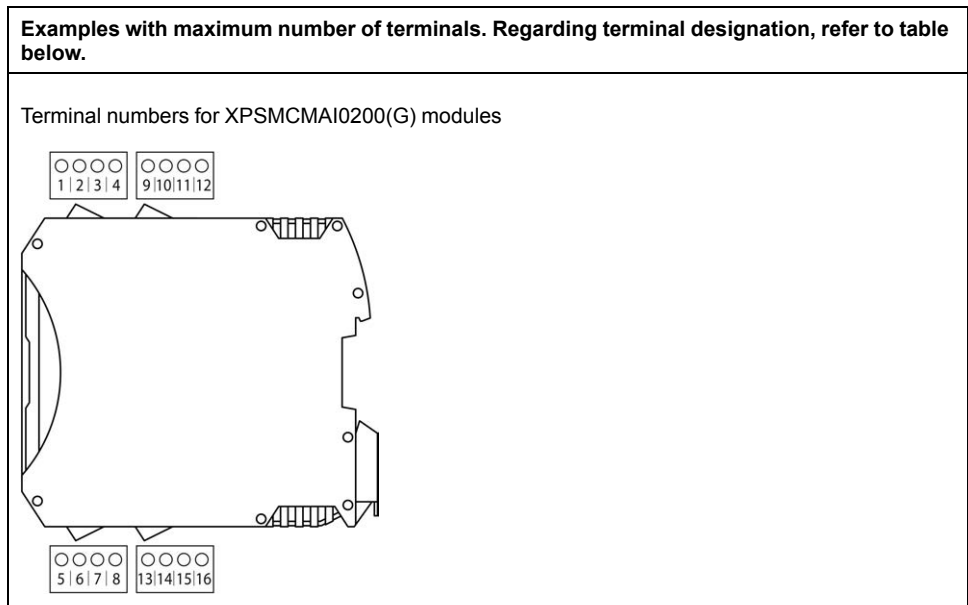

Terminal	Signal	LED	Type	Description	Operation
1	24 VDC	PWR	-	24 Vdc power supply	-
2	NODE_ADDR0	ADDR0	Input	Node selection	Input type 3 according to EN 61131-2. Maximum resistance 1.2 kΩ.
3	NODE_ADDR1	ADDR1			
4	0 VDC	PWR	-	0 Vdc power supply	-
9	24VDC_S1	CH 1	Output	Sensor 1 connections	Isolated 24 Vdc power supply for sensor 1
10	IN_S1		Input		0/20 mA sensor 1 input <sup>(1)</sup>
	NEG_S1		Input		0/10 V sensor 1 negative input <sup>(2)</sup>
11	OUT_S1		Output		0/20 mA sensor 1 output <sup>(1)</sup>
	POS_S1		Input		0/10 V sensor 1 positive input <sup>(2)</sup>
12	0 VDC_S1		Output		Isolated 0 Vdc reference for sensor 1
13	24VDC_S2	CH 2	Output	Sensor 2 connections	Isolated 24 Vdc power supply for sensor 2
14	IN_S2		Input		0/20 mA sensor 2 input <sup>(1)</sup>
	NEG_S2		Input		0/10 V sensor 2 negative input <sup>(2)</sup>
15	OUT_S2		Output		0/20 mA sensor 2 output <sup>(1)</sup>
	POS_S2		Input		0/10 V sensor 2 positive input <sup>(2)</sup>
16	0 VDC_S2		Output		Isolated 0 Vdc reference for sensor 2

**(1)** Input impedance (channel configured as current input) = 200 Ω according to EN 61131-2.

**(2)** Input impedance (channel configured as voltage input) = 250 kΩ according to EN 61131-2.

**⚠ WARNING****UNINTENDED EQUIPMENT OPERATION**

Do not connect wires to unused terminals and/or terminals indicated as "No Connection (N.C.)" or Not Connected.

**Failure to follow these instructions can result in death, serious injury, or equipment damage.**

**XPSMCMAI0400(G) Module Connector Designations**

Examples with maximum number of terminals. Regarding terminal designation, refer to table below.

Terminal numbers for XPSMCMAI0400(G) modules

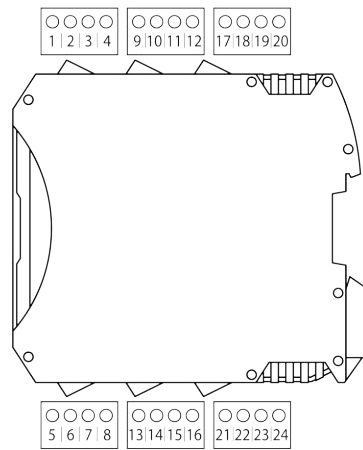

Terminal	Signal	LED	Type	Description	Operation
1	24 VDC	PWR	-	24 Vdc power supply	-
2	NODE_ADDR0	ADDR0	Input	Node selection	Input type 3 according to EN 61131-2. Maximum resistance 1.2 kΩ.
3	NODE_ADDR1	ADDR1			
4	0 VDC	PWR	-	0 Vdc power supply	-
9	24VDC_S1	CH 1	Output	Sensor 1 connections	Isolated 24 Vdc power supply for sensor 1
10	IN_S1		Input		0/20 mA sensor 1 input <sup>(1)</sup>
	NEG_S1		Input		0/10 V sensor 1 negative input <sup>(2)</sup>
11	OUT_S1		Output		0/20 mA sensor 1 output <sup>(1)</sup>
	POS_S1		Input		0/10 V sensor 1 positive input <sup>(2)</sup>
12	0 VDC_S1		Output		Isolated 0 Vdc reference for sensor 1
13	24VDC_S3	CH 3	Output	Sensor 3 connections	Isolated 24 Vdc power supply for sensor 3
14	IN_S3		Input		0/20 mA sensor 3 input <sup>(1)</sup>
	NEG_S3		Input		0/10 V sensor 3 negative input <sup>(2)</sup>
15	OUT_S3		Output		0/20 mA sensor 3 output <sup>(1)</sup>
	POS_S3		Input		0/10 V sensor 3 positive input <sup>(2)</sup>
16	0 VDC_S3		Output		Isolated 0 Vdc reference for sensor 3

Terminal	Signal	LED	Type	Description	Operation
17	24VDC_S2	CH 2	Output	Sensor 2 connections	Isolated 24 Vdc power supply for sensor 2
18	IN_S2		Input		0/20 mA sensor 2 input <sup>(1)</sup>
	NEG_S2		Input		0/10 V sensor 2 negative input <sup>(2)</sup>
19	OUT_S2		Output		0/20 mA sensor 2 output <sup>(1)</sup>
	POS_S2		Input		0/10 V sensor 2 positive input <sup>(2)</sup>
20	0 VDC_S2		Output		Isolated 0 Vdc reference for sensor 2
21	24VDC_S4	CH 4	Output	Sensor 4 connections	Isolated 24 Vdc power supply for sensor 4
22	IN_S4		Input		0/20 mA sensor 4 input <sup>(1)</sup>
	NEG_S4		Input		0/10 V sensor 4 negative input <sup>(2)</sup>
23	OUT_S4		Output		0/20 mA sensor 4 output <sup>(1)</sup>
	POS_S4		Input		0/10 V sensor 4 positive input <sup>(2)</sup>
24	0 VDC_S4		Output		Isolated 0 Vdc reference for sensor 4

(1) Input impedance (channel configured as current input) = 200 Ω according to EN 61131-2.

(2) Input impedance (channel configured as voltage input) = 250 kΩ according to EN 61131-2.

### ▲ WARNING

#### UNINTENDED EQUIPMENT OPERATION

Do not connect wires to unused terminals and/or terminals indicated as "No Connection (N.C.)" or Not Connected.

**Failure to follow these instructions can result in death, serious injury, or equipment damage.**

## Sample Wiring Diagrams

Analog signals are susceptible to electromagnetic interference. Interference may lead to unreliable analog signal values and to unintended behavior of the module.

### ▲ WARNING

#### UNINTENDED EQUIPMENT OPERATION

Use shielded cables for analog device connection and ensure the shields are terminated to Functional Earth (Ground) on both ends of the cable.

**Failure to follow these instructions can result in death, serious injury, or equipment damage.**

For more information refer to [Wiring Best Practices](#), page 28.

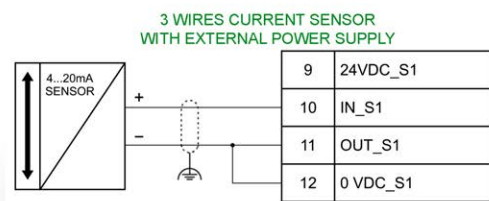
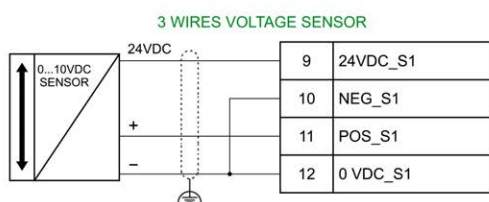
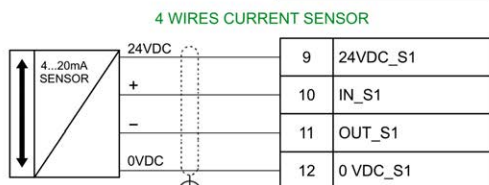
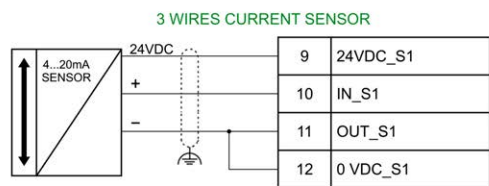
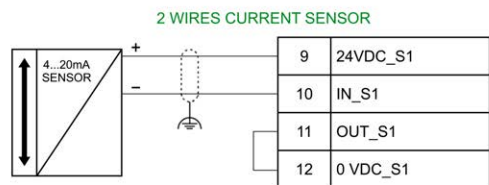

## LED Indicators

### Front-Face View

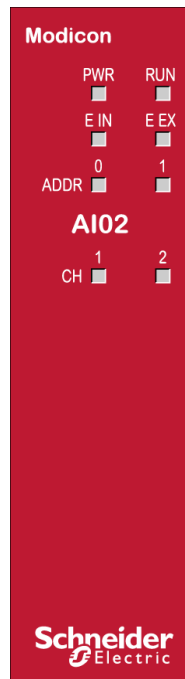

XPSMCMIAI0200(G)

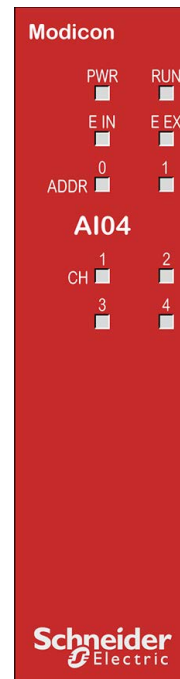

XPSMCMIAI0400(G)

## Operation States

The following table describes the indication of operation states of the XPSMCMIAI0-00(G) by means of the LEDs. The description assumes that the power LED (**PWR**) is ON:

<b>RUN</b> green	<b>E IN</b> red	<b>E EX</b> red	<b>ADDR 0...1</b> orange	<b>CH 1...4</b> red / green	<b>Meaning</b>
ON	ON	ON	ON	Red	Power on - initial test
OFF = awaiting initialization	OFF	OFF Normal operation	Encoded Node address, page 67	Red OFF, green OFF = channel not configured	Normal operation
Flashes = no inputs or outputs configured		ON Anomaly detected on measurement channel		Red OFF, green ON (only corresponding LED) = channel configured	
ON = inputs or outputs configured					

## Troubleshooting

The following tables describe the indication of detected errors of the XPSMCMIAI0-00(G) by means of the LEDs. The description assumes that the power LED (**PWR**) is ON:

Detected error	RUN green	E IN red	E EX red	ADDR 0...1 orange	CH 1...4 red/ green	Solution
Internal error detected.	OFF	2 or 3 flashes	OFF	Encoded Node address, page 67	OFF	Product non serviceable <sup>(1)</sup> .
Compatibility error detected.	OFF	3 flashes	OFF		OFF	Firmware version not compatible with controller <sup>(1)</sup> .
Error in communication with controller detected.	OFF	5 flashes	OFF		OFF	Restart the system <sup>(1)</sup> .
Error on other module or controller detected.	OFF	ON	OFF		OFF	Restart the system. Identify the expansion module affected by this condition and consult its user guide <sup>(1)</sup> .
Two units of the same module reference detected with the same node address detected.	OFF	5 flashes	5 flashes		OFF	Modify the unit node address, page 67.
Incorrect configuration detected.	OFF	5 flashes	OFF		OFF	Verify system bus connection <sup>(1)</sup> .

(1) If the condition persists, contact your local Schneider Electric representative.

**Channel configured as single or not configured:**

Detected error	RUN green	E IN red	E EX red	ADDR 0...1 orange	CH 1...4 red/ green	Solution
Sensor supply overload detected.	ON	OFF	ON	Encoded Node address, page 67	1 red flash every 600 ms	Verify sensor connections. Verify sensor status.
Input channel overload error detected.	ON	OFF	ON		1 red flash every 600 ms	Verify sensor connections. Verify sensor status.
Read value over threshold detected.	ON	OFF	ON		3 quick red flashes and a pause of 600 ms	Verify sensor connections. Verify sensor status. Verify threshold values set with SoSafe Configurable.
Read value under threshold detected.	ON	OFF	ON		3 quick red flashes and a pause of 600 ms	Verify sensor connections. Verify sensor status. Verify threshold values set with SoSafe Configurable.
Disconnected sensor detected.	ON	OFF	ON		3 quick red flashes and a pause of 600 ms	Verify sensor connections. Verify sensor status.

**Channel configured as redundant (two sensors connected):**

Detected error	RUN green	E IN red	E EX red	ADDR 0...1 orange	CH 1...4 red/ green	Solution
Sensor supply overload detected.	ON	OFF	ON	Encoded Node address, page 67	1 red flash every 600 ms	Verify sensor connections. Verify sensor status.
Input channel overload error detected.	ON	OFF	ON		1 red flash every 600 ms	Verify sensor connections. Verify sensor status.
Read value over threshold detected.	ON	OFF	ON		3 quick red flashes and a pause of 600 ms	Verify sensor connections. Verify sensor status. Verify threshold values set with SoSafe Configurable.

Detected error	RUN green	E IN red	E EX red	ADDR 0...1 orange	CH 1...4 red/ green	Solution
Read value under threshold detected.	ON	OFF	ON		3 quick red flashes and a pause of 600 ms	Verify sensor connections. Verify sensor status. Verify threshold values set with SoSafe Configurable.
Disconnected sensor detected.	ON	OFF	ON		3 quick red flashes and a pause of 600 ms	Verify sensor connections. Verify sensor status.
Read value from sensor pair out of tolerance detected.	ON	OFF	ON		1 red flash every 100 ms	Verify sensor connections. Verify sensor status. Verify threshold values set with SoSafe Configurable.
<p><b>NOTE:</b> Sensor supply overload / Input channel overload / Read value over threshold / Read value under threshold / Disconnected sensor:</p> <p>When one of these diagnostics is detected on one channel:</p> <ul style="list-style-type: none"> <li>The red LED relative to the channel with the issue flashes.</li> <li>The red LED of the other channel remains ON (no flash).</li> </ul> <p>If one of the above diagnostics is detected at the same time on both channels:</p> <ul style="list-style-type: none"> <li>The red LED of the second channel flashes.</li> <li>The red LED of the first channel remains ON (no flash).</li> </ul> <p><b>NOTE:</b> Read value from dual sensor out of tolerance detected: both LEDs of channel pair flash.</p>						

**NOTE:** To verify the isolated channel power supply overload condition, refer to module-specific characteristics table, page 75.

## Module Characteristics

### Presentation

Module-specific characteristics	
Description	Electronic housing maximum 24-poles, with locking latch mounting
Mounting	DIN rail mounting with locking latch
Rated voltage	24 Vdc ± 20 %
Channels number / description	2 (for XPSMCMAI0200(G)) or 4 (for XPSMCMAI0400(G))/ isolated (500 Vdc) between channels, and between channels and control electronics. Each channel can be configured as voltage input or current input.
Diagnostic	
Isolated sensor supply overload detection (if the sensor draws more than 30 mA)	Yes with active protection <sup>(1)</sup> .
Input overvoltage / input overcurrent detection	Yes with active protection <sup>(1)</sup> .
Disconnected cable detection	Yes
Overthreshold / underthreshold detection	Yes
Redundant channels mismatch detection	Yes
Probability of a dangerous failure per hour (PFHd)	XPSMCMAI0400(G) : 1.53E-8 XPSMCMAI0200(G): 9.54E-9
Mean Time to Dangerous Failure (MTTFd) in years	XPSMCMAI0400(G) : 106 XPSMCMAI0200(G): 186
Connection to expansion modules	5-way backplane expansion

Module-specific characteristics	
Weight	XPSMCMAI0400(G): 0.164 kg (5.78 oz) XPSMCMAI0200(G): 0.127 kg (4.47 oz)
<b>(1)</b> When this condition is detected, the power supply of the sensor is disconnected for 1 second and then rearmed. The disconnection and rearming of the power supply continues until the over-current condition has been removed.	

Module current inputs	
Nominal range	0...20 mA / 4...20 mA
User selectable allowable current limits	0...23 mA (if 0...20 mA selected), 2.5...23 mA (if 4...20 mA is selected)
Digital resolution	16-bit
Resolution value	381 nA
Sample rate (samples per second)	User selectable. Allowable values: 2.5, 5, 10, 16.6, 20, 50, 60, 100, 200, 400, 800, 1000, 2000, 4000
Input impedance	200 Ω
Maximum input current	23 mA

Module voltage inputs	
Range	0...10 Vdc
User selectable allowable voltage limits	0...11.5 Vdc
Digital resolution	16-bit
Resolution value	152 μV
Sample rate (samples per second)	User selectable. Allowable values: 2.5, 5, 10, 16.6, 20, 50, 60, 100, 200, 400, 800, 1000, 2000, 4000
Input impedance	250 kΩ

**⚠ DANGER**

**FIRE HAZARD**

Use only the correct wire sizes for the maximum current capacity of the I/O channels and power supplies.

**Failure to follow these instructions will result in death or serious injury.**

**⚠ WARNING**

**UNINTENDED EQUIPMENT OPERATION**

Do not exceed any of the rated values specified in the characteristics tables.

**Failure to follow these instructions can result in death, serious injury, or equipment damage.**

**NOTE:** For the characteristics common to all modules, refer to General Characteristics, page 24.

# XPSMCMDI0800(G) and XPSMCMDI1600(G) Input Expansion Modules

## Module and Functional Description

### Presentation

The XPSMCMDI0800(G) and XPSMCMDI1600(G) are input expansion modules for the XPSMCM• Modular Safety Controller. The XPSMCMDI0800(G) and XPSMCMDI1600(G) modules are configured with the XPSMCM• Modular Safety Controller. The XPSMCMDI0800(G) module provides 8 safety-related inputs and the XPSMCMDI1600(G) module provides 16 safety-related inputs.

The expansion module supports two inputs `NODE_ADDR0` and `NODE_ADDR1` which are used to set a physical address to the module:

	<b>NODE_ADDR0 (Terminal 2)</b>	<b>NODE_ADDR1 (Terminal 3)</b>
NODE 0	0 (or not connected)	0 (or not connected)
NODE 1	24 Vdc	0 (or not connected)
NODE 2	0 (or not connected)	24 Vdc
NODE 3	24 Vdc	24 Vdc

**NOTE:** Do not use the same physical address for two units of the same module reference.

**NOTE:** The LEDs **ADDR 1** and **ADDR 0** correspond to the `NODE_ADDR1` and `NODE_ADDR0` in this table respectively.

**NOTE:** The node address wiring must match the configuration settings.

### Output TEST

For more information, refer to Output TEST, page 37.

## Connector Designations and Sample Wiring Diagram

### XPSMCMDI0800(G) and XPSMCMDI1600(G) Module Connector Designations

The connections for the XPSMCMDI1600(G) module are identical with the other 8 inputs occupying terminals 17 through 24.

Terminal	Signal	LED	Type	Description	Operation
1	24 VDC	PWR	-	24 Vdc power supply	—
2	<code>NODE_ADDR0</code>	ADDR0	Input	Node selection	Input type 3 according to EN 61131-2. Maximum resistance 1.2 kΩ.
3	<code>NODE_ADDR1</code>	ADDR1			
4	0 VDC	PWR	-	0 Vdc power supply	—
5	INPUT1	IN 1	Input	Safety-related input 1	Input type 3 according to EN 61131-2. Maximum resistance 1.2 kΩ.
6	INPUT2	IN 2		Safety-related input 2	
7	INPUT3	IN 3		Safety-related input 3	

Terminal	Signal	LED	Type	Description	Operation
8	INPUT4	IN 4		Safety-related input 4	
9	OUT_TEST1	–	Output	Test output for detection of short circuits/cross circuits in input circuits	PNP active at 24 Vdc.
10	OUT_TEST2	–			
11	OUT_TEST3	–			
12	OUT_TEST4	–			
13	INPUT5	IN 5	Input	Safety-related input 5	Input type 3 according to EN 61131-2. Maximum resistance 1.2 kΩ.
14	INPUT6	IN 6		Safety-related input 6	
15	INPUT7	IN 7		Safety-related input 7	
16	INPUT8	IN 8		Safety-related input 8	

### XPSMCMDI0800(G) and XPSMCMDI1600(G) Module Sample Wiring Diagram

The connections for the XPSMCMDI1600(G) module are identical with the other 8 inputs occupying terminals 17 through 24.

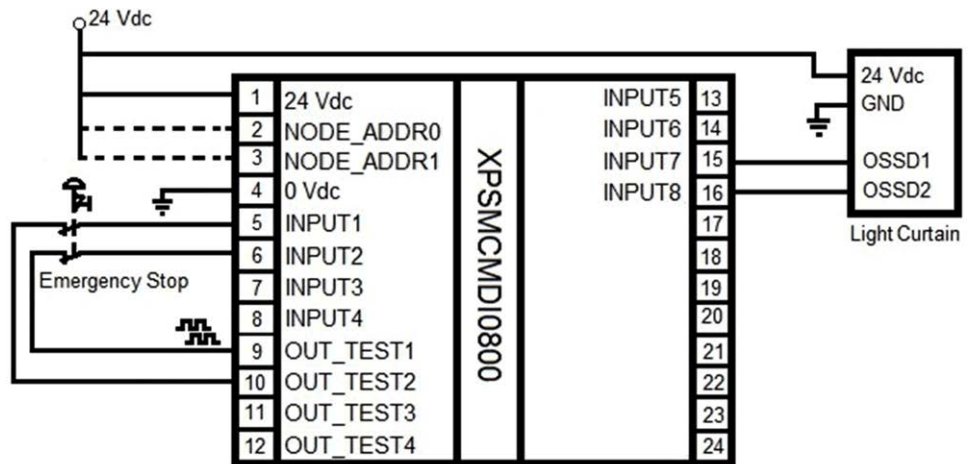

**NOTE:** Best practice dictates the use of fusing on the incoming 24 Vdc power, and sized appropriately for the requirements of the module.

# LED Indicators

## Front-Face View

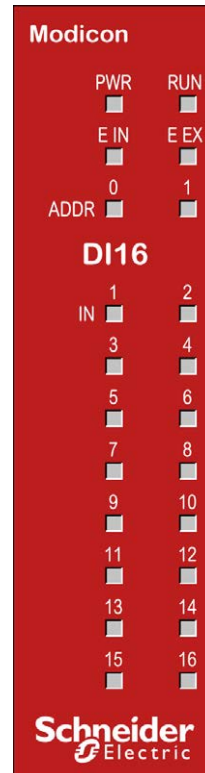
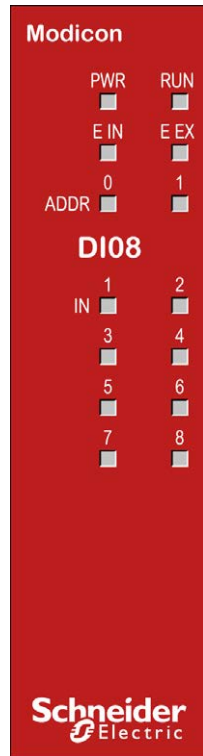

## Operation States

The following table describes the indication of operation states of the XPSMCMDI0800(G) by means of the LEDs. The LED descriptions for the XPSMCMDI1600(G) are identical. The description assumes that the power LED (**PWR**) is ON:

<b>RUN</b> green	<b>E IN</b> red	<b>E EX</b> red	<b>ADDR 0...1</b> orange	<b>IN 1...8 (16)</b> yellow	<b>Meaning</b>	
ON	ON	ON	ON	ON	Power on - initial test	
OFF = awaiting initialization	OFF	OFF /	Encoded Node address, page 77	Input state	Normal operation	
Flashing = no inputs or outputs configured		ON = Wiring error detected				Flashing = input with error
ON = inputs or outputs configured						

## Troubleshooting

The following table describes the indication of detected errors of the XPSMCMDI0800(G) by means of the LEDs. The LED descriptions for the XPSMCMDI1600(G) are identical. The description assumes that the power LED (**PWR**) is ON:

Detected error	RUN green	E IN red	E EX red	IN 1...8 (16) yellow	Solution
Internal error detected.	OFF	2 or 3 flashes	OFF	OFF	Product non serviceable <sup>(1)</sup> .
Compatibility error detected.	OFF	5 flashes	OFF	5 flashes	Firmware version not compatible with the controller <sup>(1)</sup> .
Error detected in the communication with controller.	OFF	5 flashes	OFF	OFF	Reboot the system <sup>(1)</sup> .
Error detected on other expansion module or controller.	OFF	ON	OFF	OFF	Reboot the system.  Verify which module /controller is in error and consult its troubleshooting guide.
Two units of the same module reference detected with the same node address.	OFF	5 flashes		OFF	Modify the unit node address, page 77.
<b>(1)</b> If the condition persists, contact your local Schneider Electric representative.					

## Module Characteristics

### Presentation

Module-specific characteristics	XPSMCMDI0800(G)	XPSMCMDI1600(G)
Reference description	Electronic housing maximum 16-poles, with locking latch mounting	Electronic housing maximum 24-poles, with locking latch mounting
Node address (No./description)	2 / Input type 3 according to EN 61131-2. Maximum applicable resistance 1.2 kΩ.	
Digital inputs (No./description)	8 / Input type 3 according to EN 61131-2. Maximum applicable resistance 1.2 kΩ.	16 / Input type 3 according to EN 61131-2. Maximum applicable resistance 1.2 kΩ.
Test output (No./description)	4 / to test for cross circuits - short circuits, maximum current 100 mA, nominal voltage / 24 Vdc	
Probability of a dangerous failure per hour (PFHd)	4.46E-9	4.93E-9
Mean Time to Dangerous Failure (MTTFd) in years	474	398
Connection to expansion modules	5-way backplane expansion	
Weight	0.12 kg (4.2 oz)	

**NOTE:** For the characteristics common to all modules, refer to General Characteristics, page 24.

### **⚠ DANGER**

#### **FIRE HAZARD**

Use only the correct wire sizes for the maximum current capacity of the I/O channels and power supplies.

**Failure to follow these instructions will result in death or serious injury.**

### **⚠ WARNING**

#### **UNINTENDED EQUIPMENT OPERATION**

Do not exceed any of the rated values specified in the characteristics tables.

**Failure to follow these instructions can result in death, serious injury, or equipment damage.**

# XPSMCM DI1200MT(G) Input Expansion Module

## Module and Functional Description

### Presentation

The XPSMCM DI1200MT(G) is an input expansion module for the XPSMCM• Modular Safety Controller. The XPSMCM DI1200MT(G) module is configured with the XPSMCM• Modular Safety Controller. The XPSMCM DI1200MT(G) module provides 12 safety-related inputs.

The expansion module supports two inputs `NODE_ADDR0` and `NODE_ADDR1` which are used to set a physical address to the module:

	<b>NODE_ADDR0 (Terminal 2)</b>	<b>NODE_ADDR1 (Terminal 3)</b>
NODE 0	0 (or not connected)	0 (or not connected)
NODE 1	24 Vdc	0 (or not connected)
NODE 2	0 (or not connected)	24 Vdc
NODE 3	24 Vdc	24 Vdc

**NOTE:** Do not use the same physical address for two units of the same module reference.  
**NOTE:** The LEDs **ADDR 1** and **ADDR 0** correspond to the `NODE_ADDR1` and `NODE_ADDR0` in this table respectively.  
**NOTE:** The node address wiring must match the configuration settings.

### Output TEST

For more information, refer to Output TEST, page 37.

## Connector Designations and Sample Wiring Diagram

### XPSMCM DI1200MT(G) Module Connector Designations

Terminal	Signal	LED	Type	Description	Operation
1	24 VDC	PWR	–	24 Vdc power supply	–
2	<code>NODE_ADDR0</code>	ADD-R0	Input	Node selection	Input type 3 according to EN 61131-2. Maximum resistance 1.2 kΩ.
3	<code>NODE_ADDR1</code>	ADD-R1			
4	0 VDC	PWR	–	0 Vdc power supply	-
5	INPUT1	IN 1	Input	Safety-related input 1	Input type 3 according to EN 61131-2. Maximum resistance 1.2 kΩ.
6	INPUT2	IN 2		Safety-related input 2	
7	INPUT3	IN 3		Safety-related input 3	
8	INPUT4	IN 4		Safety-related input 4	
9	OUT_TEST1	–	Output	Test output for detection of short circuits/cross circuits in input circuits	PNP active at 24 Vdc.
10	OUT_TEST2				
11	OUT_TEST3				

Terminal	Signal	LED	Type	Description	Operation
12	OUT_TEST4				
13	INPUT5	IN 5	Input	Safety-related input 5	Input type 3 according to EN 61131-2. Maximum resistance 1.2 kΩ.
14	INPUT6	IN 6		Safety-related input 6	
15	INPUT7	IN 7		Safety-related input 7	
16	INPUT8	IN 8		Safety-related input 8	
17	OUT_TEST5	-	Output	Test output for detection of short circuits/cross circuits in input circuits	PNP active at 24 Vdc.
18	OUT_TEST6				
19	OUT_TEST7				
20	OUT_TEST8				
21	INPUT9	IN 9	Input	Safety-related input 9	Input type 3 according to EN 61131-2. Maximum resistance 1.2 kΩ.
22	INPUT10	IN 10		Safety-related input 10	
23	INPUT11	IN 11		Safety-related input 11	
24	INPUT12	IN 12		Safety-related input 12	

### XPSMCM1200MT(G) Module Sample Wiring Diagram

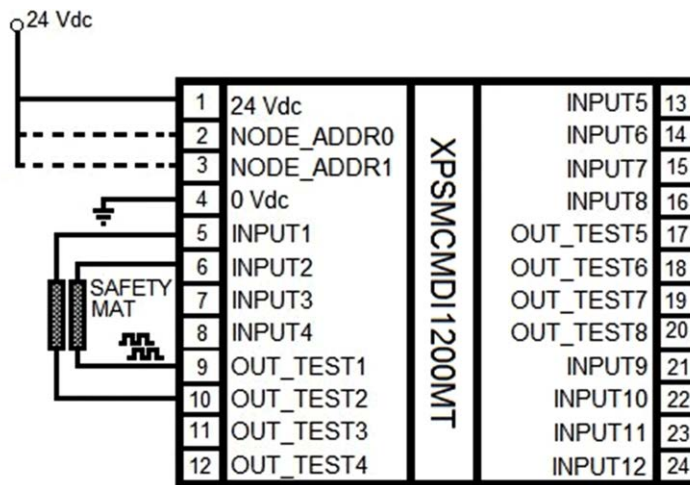

**NOTE:** Best practice dictates the use of fusing on the incoming 24 Vdc power, and sized appropriately for the requirements of the module.

# LED Indicators

## Front-Face View

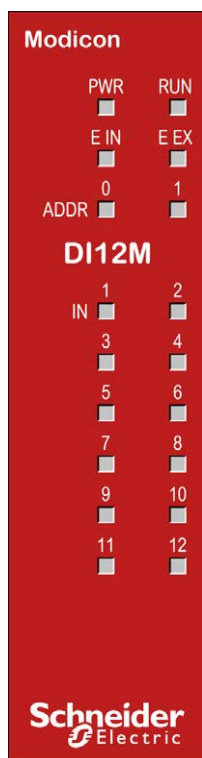

## Operation States

The following table describes the indication of operation states of the XPSMCMDI1200MT(G) by means of the LEDs. The description assumes that the power LED (**PWR**) is ON:

<b>RUN</b> green	<b>E IN</b> red	<b>E EX</b> red	<b>ADDR 0...1</b> orange	<b>IN 1...12</b> yellow	<b>Meaning</b>
ON	ON	ON	ON	ON	Power on - initial test
OFF = awaiting initialization	OFF	OFF	Encoded Node address, page 81	Input state Flashing = input with error	Normal operation
Flashing = no inputs or outputs configured					
ON = inputs or outputs configured					

## Troubleshooting

The following table describes the indication of detected errors of the XPSMCMDI1200MT(G) by means of the LEDs. The description assumes that the power LED (**PWR**) is ON:

<b>Detected error</b>	<b>RUN</b> green	<b>E IN</b> red	<b>E EX</b> red	<b>IN 1...12</b> yellow	<b>Solution</b>
Internal error detected	OFF	2 or 3 flashes	OFF	OFF	Product non serviceable <sup>(1)</sup> .
Compatibility error detected.	OFF	5 flashes	OFF	5 flashes	Firmware version not compatible with the controller <sup>(1)</sup> .
Error detected in the communication with controller.	OFF	5 flashes	OFF	OFF	Reboot the system <sup>(1)</sup> .

Detected error	RUN green	E IN red	E EX red	IN 1...12 yellow	Solution
Error detected on other expansion module or controller.	OFF	ON	OFF	OFF	Reboot the system.  Verify which module /controller is in error and consult its troubleshooting guide.
Two units of the same module reference detected with the same node address.	OFF	5 flashes		OFF	Modify the unit node address, page 81 <i>NODE ADDR.</i>
<b>(1)</b> If the condition persists, contact your local Schneider Electric representative.					

## Module Characteristics

### Presentation

Module-specific characteristics	
Reference description	Electronic housing maximum 24-poles, with locking latch mounting
Node address (No./description)	2 / Input type 3 according to EN 61131-2. Maximum applicable resistance 1.2 kΩ.
Digital inputs (No./description)	12 / Input type 3 according to EN 61131-2. Maximum applicable resistance 1.2 kΩ.
Test output (No./description)	8 / to test for cross circuits - short circuits, maximum current 100 mA nominal voltage / 24 Vdc
Probability of a dangerous failure per hour (PFHd)	5.60E-9
Mean Time to Dangerous Failure (MTTFd) in years	323
Connection to expansion modules	5-way backplane expansion
Weight	0.12 kg (4.2 oz)

**NOTE:** For the characteristics common to all modules, refer to General Characteristics, page 24.

### **⚠ DANGER**

#### **FIRE HAZARD**

Use only the correct wire sizes for the maximum current capacity of the I/O channels and power supplies.

**Failure to follow these instructions will result in death or serious injury.**

### **⚠ WARNING**

#### **UNINTENDED EQUIPMENT OPERATION**

Do not exceed any of the rated values specified in the characteristics tables.

**Failure to follow these instructions can result in death, serious injury, or equipment damage.**

# XPSMCMDO0002(G) and XPSMCMDO0004(G) Output Expansion Modules

## Module and Functional Description

### Presentation

The XPSMCMDO0002(G) and XPSMCMDO0004(G) are output expansion modules for the XPSMCM• Modular Safety Controller. The XPSMCMDO0002(G) and XPSMCMDO0004(G) modules are configured with the XPSMCM• Modular Safety Controller. The XPSMCMDO0002(G) module provides two dual-channel safety-related outputs and two status outputs. The XPSMCMDO0004(G) module provides four dual-channel safety-related outputs and four status outputs.

The expansion module supports two inputs `NODE_ADDR0` and `NODE_ADDR1` which are used to set a physical address to the module:

	<b>NODE_ADDR0 (Terminal 2)</b>	<b>NODE_ADDR1 (Terminal 3)</b>
NODE 0	0 (or not connected)	0 (or not connected)
NODE 1	24 Vdc	0 (or not connected)
NODE 2	0 (or not connected)	24 Vdc
NODE 3	24 Vdc	24 Vdc

**NOTE:** Do not use the same physical address for two units of the same module reference.  
**NOTE:** The LEDs **ADDR 1** and **ADDR 0** correspond to the `NODE_ADDR1` and `NODE_ADDR0` in this table respectively.  
**NOTE:** The node address wiring must match the configuration settings.

### Input RESTART (RST)

For more information, refer to Input RESTART (RST), page 37.

### Output STATUS (SIL 1/PL c in Accordance with Standard EN 61508:2010)

The status outputs are configurable digital diagnostic outputs that indicate the status of safety-related inputs and/or outputs.

For more information, refer to Output STATUS, page 107.

### Solid-State Safety-Related Output (OSSD)

For more information, refer to Solid-State safety-related output (OSSD), page 38.

## Connector Designations and Sample Wiring Diagram

### XPSMCMDO0002(G) Module Connector Designations

Terminal	Signal	LED	Type	Description	Operation
1	24 VDC	PWR	–	24 Vdc power supply	–
2	NODE_ADDR0	ADDR0	Input	Node selection	Input type 3 according to EN 61131-2. Maximum resistance 1.2 kΩ.

Terminal	Signal	LED	Type	Description	Operation
3	NODE_ADDR1	ADDR1			
4	0 VDC	PWR	–	0 Vdc power supply	–
5	OSSD1_A	OSSD 1	Output	Safety-related output 1	PNP active at Uv (24 Vdc ± 20%).
6	OSSD1_B				
7	RESTART1	RST 1	Input	Feedback/Restart 1	Input type 3 according to EN 61131-2. Maximum resistance 1.2 kΩ.
8	OUT_STATUS 1	STATUS 1	Output	Configurable diagnostic output	Configurable output (SIL 1/PL c in accordance with EN 61508:2010)
9	OSSD2_A	OSSD 2	Output	Safety-related output 2	PNP active at Uv (24 Vdc ± 20%).
10	OSSD2_B				
11	RESTART2	RST 2	Input	Feedback/Restart 2	Input type 3 according to EN 61131-2. Maximum resistance 1.2 kΩ.
12	OUT_STATUS 2	STATUS 2	Output	Configurable diagnostic output	Configurable output (SIL 1/PL c in accordance with EN 61508:2010)
13	24 VDC	–	–	24 Vdc power supply	OSSD1/2 power supply
14	n.c.	–	–	–	–
15	0 VDC	–	–	0 Vdc power supply	–
16	n.c.	–	–	–	–

## XPSMCMDO0004(G) Module Connector Designations

Terminal	Signal	LED	Type	Description	Operation
1	24 VDC	PWR	–	24 Vdc power supply	–
2	NODE_ADDR0	ADDR0	Input	Node selection	Input type 3 according to EN 61131-2. Maximum resistance 1.2 kΩ.
3	NODE_ADDR1	ADDR1			
4	0 VDC	PWR	–	0 Vdc power supply	–
5	OSSD1_A	OSSD 1	Output	Safety-related output 1	PNP active at Uv (24 Vdc ± 20%).
6	OSSD1_B				
7	RESTART1	RST 1	Input	Feedback/Restart 1	Input type 3 according to EN 61131-2. Maximum resistance 1.2 kΩ.
8	OUT_STATUS 1	STATUS 1	Output	Configurable diagnostic output	Configurable output (SIL 1/PL c in accordance with EN 61508:2010)
9	OSSD2_A	OSSD 2	Output	Safety-related output 2	PNP active at Uv (24 Vdc ± 20%).
10	OSSD2_B				
11	RESTART2	RST 2	Input	Feedback/Restart 2	Input type 3 according to EN 61131-2. Maximum resistance 1.2 kΩ.
12	OUT_STATUS 2	STATUS 2	Output	Configurable diagnostic output	Configurable output (SIL 1/PL c in accordance with EN 61508:2010)

Terminal	Signal	LED	Type	Description	Operation
13	24 VDC	–	–	24 Vdc power supply	OSSD1/2 power supply
14	24 VDC	–	–	24 Vdc power supply	OSSD3/4 power supply
15	0 VDC	–	–	0 Vdc power supply	–
16					
17	OSSD4_A	OSSD 4	Output	Safety-related output 4	PNP active at Uv (24 Vdc ± 20%).
18	OSSD4_B				
19	RESTART4	RST 4	Input	Feedback/Restart 4	Input type 3 according to EN 61131-2. Maximum resistance 1.2 kΩ.
20	OUT_STATUS4	STATUS 4	Output	Configurable diagnostic output	Configurable output (SIL 1/PL c in accordance with EN 61508:2010)
21	OSSD3_A	OSSD 3	Output	Safety-related output 3	PNP active at Uv (24 Vdc ± 20%).
22	OSSD3_B				
23	RESTART3	RST 3	Input	Feedback/Restart 3	Input type 3 according to EN 61131-2. Maximum resistance 1.2 kΩ.
24	OUT_STATUS 3	STATUS 3	Output	Configurable diagnostic output	Configurable output (SIL 1/PL c in accordance with EN 61508:2010)

### XPSMCMDO0002(G) Module Sample Wiring Diagram

Category 3 wiring for XPSMCMDO0002(G):

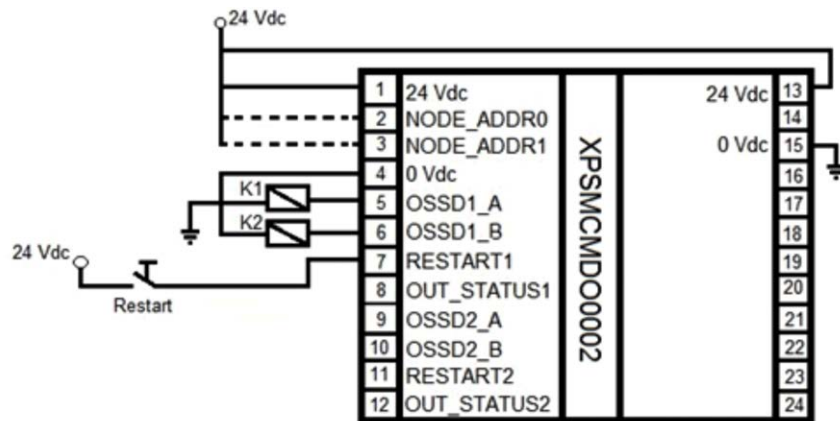

**NOTE:** Best practice dictates the use of fusing on the incoming 24 Vdc power, and sized appropriately for the requirements of the module.

Category 4 wiring for XPSMCMDO0002(G) with feedback of the contactors K1 and K2:

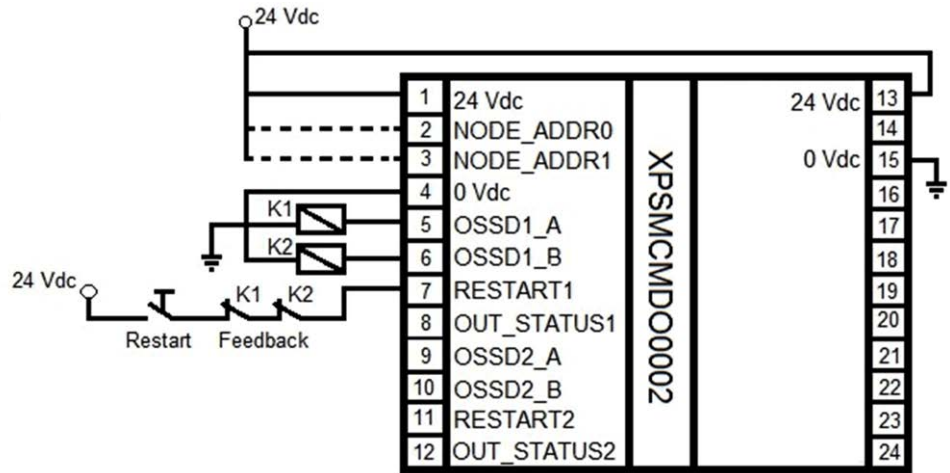

**NOTE:** Best practice dictates the use of fusing on the incoming 24 Vdc power, and sized appropriately for the requirements of the module.

### XPSMCMDO0004(G) Module Sample Wiring Diagram

Category 3 wiring for XPSMCMDO0004(G):

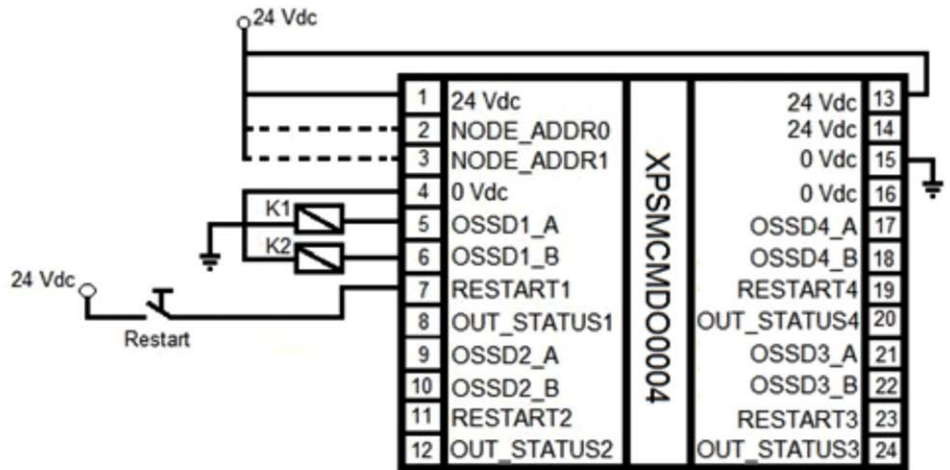

**NOTE:** Best practice dictates the use of fusing on the incoming 24 Vdc power, and sized appropriately for the requirements of the module.

Category 4 wiring for XPSMCMDO0004(G) with feedback of the contactors K1 and K2:

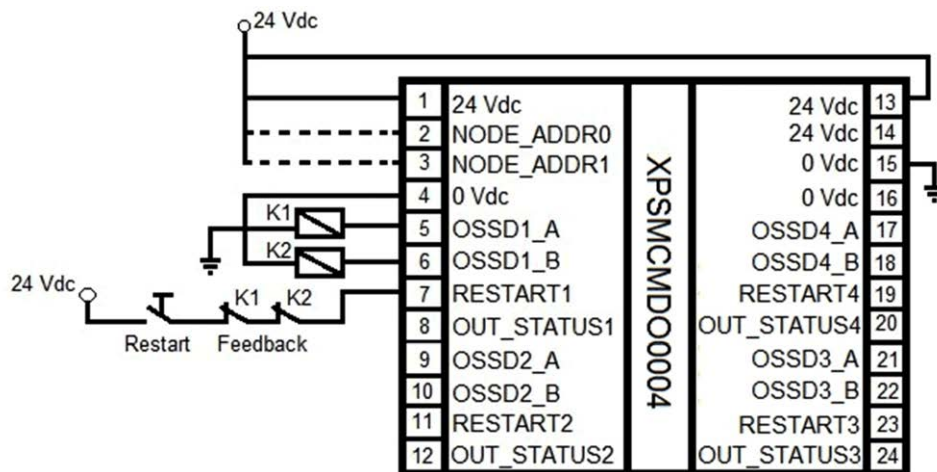

**NOTE:** Best practice dictates the use of fusing on the incoming 24 Vdc power, and sized appropriately for the requirements of the module.

## LED Indicators

### Front-Face View

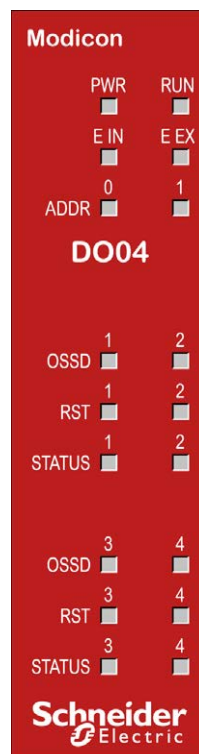
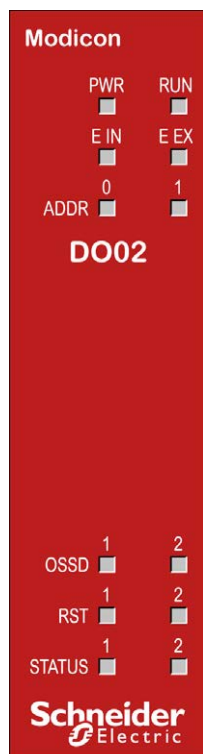

## Operation States

The following table describes the indication of operation states of the XPSMCMDO0002(G) by means of the LEDs. The LED descriptions for the

XPSMCMDO0004(G) are identical. The description assumes that the power LED (PWR) is ON:

RUN green	E IN red	E EX red	ADDR 1...2 orange	OSSD 1...2 (4) red/green	RST 1...2 (4) yellow	STATUS 1...2 (4) yellow	Meaning
ON	ON	ON	ON	RED	ON	ON	Power on - initial test
OFF = awaiting initialization	OFF	OFF ON = Wiring error detected	Encoded Node address, page 85	Red = output ON Green = output OFF	ON = waiting for restart Flashing = no feedback	Output diagnostics	Normal operation
Flashing = no inputs or outputs configured							
ON = inputs or outputs configured							

## Troubleshooting

The following table describes the indication of detected errors of the XPSMCMDO0002(G) by means of the LEDs. The LED descriptions for the XPSMCMDO0004(G) are identical. The description assumes that the power LED (PWR) is ON:

Detected error	RUN green	E IN red	E EX red	OSSD 1...2 (4) red/green	RST 1...2 (4) yellow	STATUS 1...2 (4) yellow	Solution
Internal error detected.	OFF	2 or 3 flashes	OFF	Red	OFF	OFF	Product non serviceable <sup>(1)</sup> .
Compatibility error detected.	OFF	5 flashes	OFF	5 flashes			Firmware version not compatible with the controller <sup>(1)</sup> .
OSSD output error detected.	OFF	4 flashes	OFF	4 flashes	OFF	OFF	Verify solid-state safety-related output (OSSD) 1/2 connections <sup>(1)</sup> .
Error detected in the communication with controller.	OFF	5 flashes	OFF	OFF	OFF	OFF	Reboot the system <sup>(1)</sup> .
Error detected on other expansion module or controller.	OFF	ON	OFF	OFF	OFF	OFF	Reboot the system. Verify which module /controller is in error and consult its troubleshooting guide.
Two units of the same module reference detected with the same node address.	OFF	5 flashes		OFF	OFF	OFF	Modify the unit node address, page 85.
No power supply detected on OSSD 3,4 (MO4 only).	ON	OFF	ON	Red flashes	Flashes	Output condition	Connect 13 and 14 pins to power supply.
Error detected on node detection circuit.	OFF	3 flashes	OFF	OFF	OFF	OFF	Product non serviceable <sup>(1)</sup> .
<b>(1)</b> If the condition persists, contact your local Schneider Electric representative.							

# Module Characteristics

## Presentation

Module-specific characteristics	XPSMCMDO0002(G)	XPSMCMDO0004(G)
Reference description	Electronic housing maximum 16-poles, with locking latch mounting	Electronic housing maximum 24-poles, with locking latch mounting
Node address (No./description)	2 / Input type 3 according to EN 61131-2. Maximum applicable resistance 1.2 kΩ.	
Restart Input (No./description)	2 / EDM (External Device Monitoring) input type 3 according to EN 61131-2. Maximum applicable resistance 1.2 kΩ. / Possible automatic restart function or manual operation with restart pushbutton	
Solid-state safety-related output (OSSD) (No./description)	2 pairs / solid-state safety-related outputs PNP active high	4 pairs / solid-state safety-related outputs PNP active high
	<ul style="list-style-type: none"> <li>• The outputs are able to supply:                             <ul style="list-style-type: none"> <li>◦ In the ON condition: <math>U_v - 0.75 V \dots U_v</math> where <math>U_v = 24 V_{dc} \pm 20\%</math></li> <li>◦ In the OFF condition: 0 to 2 V<sub>rms</sub> (root mean square)</li> </ul> </li> <li>• The maximum load current of 400 mA (per OSSD) corresponds to a minimum resistive load of 60 Ω.                             <ul style="list-style-type: none"> <li>◦ The maximum capacitive load is 0.68 μF.</li> <li>◦ The maximum inductive load is 2 mH.</li> </ul> </li> <li>• To detect short circuit and line break on the outputs, a line monitoring is made by using an output pulse on each channel. The output pulse is generated every 5.5 ms with a pulse of 100 microseconds.</li> </ul>	
Status outputs	Maximum output current per channel: 100 mA, nominal voltage 24 Vdc	
Probability of a dangerous failure per hour (PFHd)	4.08E-9	5.83E-9
Mean Time to Dangerous Failure (MTTFd) in years	954	686
Connection to expansion modules	5-way backplane expansion	
Weight	0.12 kg (4.2 oz)	

**NOTE:** For the characteristics common to all modules, refer to General Characteristics, page 24.

**⚠ DANGER**

**FIRE HAZARD**

Use only the correct wire sizes for the maximum current capacity of the I/O channels and power supplies.

**Failure to follow these instructions will result in death or serious injury.**

**⚠ WARNING**

**UNINTENDED EQUIPMENT OPERATION**

Do not exceed any of the rated values specified in the characteristics tables.

**Failure to follow these instructions can result in death, serious injury, or equipment damage.**

# XPSMCMDO00042A(G) Output Expansion Module

## Module and Functional Description

### Presentation

The XPSMCMDO00042A(G) is an output expansion module for the XPSMCM• Modular Safety Controller. The XPSMCMDO00042A(G) is configured with the XPSMCM• Modular Safety Controller. The XPSMCMDO00042A(G) module provides four solid state safety-related high current outputs which can be used as four single or two dual (Output Signal Switching Device, OSSD) and eight SIL 1/PL c status outputs.

The expansion module supports two inputs `NODE_ADDR0` and `NODE_ADDR1` which are used to set a physical address to the module:

	<b>NODE_ADDR0 (Terminal 2)</b>	<b>NODE_ADDR1 (Terminal 3)</b>
NODE 0	0 (or not connected)	0 (or not connected)
NODE 1	24 Vdc	0 (or not connected)
NODE 2	0 (or not connected)	24 Vdc
NODE 3	24 Vdc	24 Vdc

**NOTE:** Do not use the same physical address for two units of the same module reference.  
**NOTE:** The LEDs **ADDR 1** and **ADDR 0** correspond to the `NODE_ADDR1` and `NODE_ADDR0` in this table respectively.  
**NOTE:** The node address wiring must match the configuration settings.

### Input RESTART (RST)

For more information, refer to the description of the Input RESTART of the XPSMCMC10804(G), page 44.

### Output STATUS (SIL 1/PL c in Accordance with Standard EN 61508:2010)

The status outputs are configurable digital diagnostic outputs that indicate the status of safety-related inputs and/or outputs.

For more information, refer to Output STATUS, page 107.

### Solid-State Safety-Related Output (OSSD)

<b>⚠ WARNING</b>
<p><b>UNINTENDED EQUIPMENT OPERATION</b></p> <p>Do not connect any equipment to an OSSD unless the OSSD is appropriately configured with SoSafe Configurable.</p> <p><b>Failure to follow these instructions can result in death, serious injury, or equipment damage.</b></p>

When using XPSMCMDO00042A(G) with sum output current > 5 A, then separate adjacent modules by interposing a XPSMCMCN0000SG connector.

Only one side of the XPSMCMDO00042A(G) module must be free. That is, mounting the module at either end(s) of the physical configuration would not require the connector. Modules mounted within the physical configuration require a connector on one side or the other, but not both.

<b>▲ WARNING</b>
<p><b>OVERHEATING AND FIRE</b></p> <p>Separate adjacent XPSMCMDO00042A(G) modules either by interposing a XPSMCMCN0000SG connector between it and adjacent modules, or by ensuring that it is the first and/or last module in the physical configuration.</p> <p><b>Failure to follow these instructions can result in death, serious injury, or equipment damage.</b></p>

XPSMCMDO00042A(G) provides 4 higher current safety-related outputs single channel (2 A maximum per channel).

Different output configurations (configurable with SoSafe Configurable) can be set:

- 4 single channels (1 safety-related output per channel with its corresponding feedback input).
- 2 dual channels (2 safety-related outputs with their corresponding feedback input per channel).
- 1 dual channel and 2 single channels.

**NOTE:** To ensure the correct operation of the OSSD 1,2,3,4, you must connect terminals 1 and 14 to power supply Uv (24 Vdc ± 20%).

## Connector Designations and Sample Wiring Diagrams

### XPSMCMDO00042A(G) Module Connector Designations

Terminal	Signal	LED	Type	Description	Operation
1	24 VDC	PWR	-	24 Vdc power supply	-
2	NODE_ADDR0	ADDR0	Input	Node selection	Input type 3 according to EN 61131-2. Maximum resistance 1.2 kΩ.
3	NODE_ADDR1	ADDR1			
4	0 VDC	PWR	-	0 Vdc power supply	-
5	RESTART_FBK1	RST 1	Input	Feedback/restart 1 for OSSD1	Input type 3 according to EN 61131-2. Maximum resistance 1.2 kΩ.
6	RESTART_FBK2	RST 2	Input	Feedback/restart 2 for OSSD2	Input type 3 according to EN 61131-2. Maximum resistance 1.2 kΩ.
7	RESTART_FBK3	RST 3	Input	Feedback/restart 3 for OSSD3	Input type 3 according to EN 61131-2. Maximum resistance 1.2 kΩ.
8	RESTART_FBK4	RST 4	Input	Feedback/restart 4 for OSSD4	Input type 3 according to EN 61131-2. Maximum resistance 1.2 kΩ.
9	OSSD1	OSSD 1	Output	Safety-related output 1	PNP active at Uv (24 Vdc ± 20%).
10	OSSD2	OSSD 2	Output	Safety-related output 2	
11	OSSD3	OSSD 3	Output	Safety-related output 3	
12	OSSD4	OSSD 4	Output	Safety-related output 4	
13	-	-	-	-	-
14	24 VDC	PWR	-	24 Vdc power supply	-
15	-	-	-	-	-
16	-	-	-	-	-
17	OUT_STATUS1	STATUS 1	Output	Configurable output 1	Configurable output (SIL 1/PL c in accordance with EN 61508:2010)
18	OUT_STATUS2	STATUS 2		Configurable output 2	

Terminal	Signal	LED	Type	Description	Operation
19	OUT_STATUS3	STATUS 3		Configurable output 3	
20	OUT_STATUS4	STATUS 4		Configurable output 4	
21	OUT_STATUS5	STATUS 5		Configurable output 5	
22	OUT_STATUS6	STATUS 6		Configurable output 6	
23	OUT_STATUS7	STATUS 7		Configurable output 7	
24	OUT_STATUS8	STATUS 8		Configurable output 8	

## Modular Safety Controller Sample Wiring Diagram

The following internal wiring diagram depicts the difference between single and dual channel logic within the module:

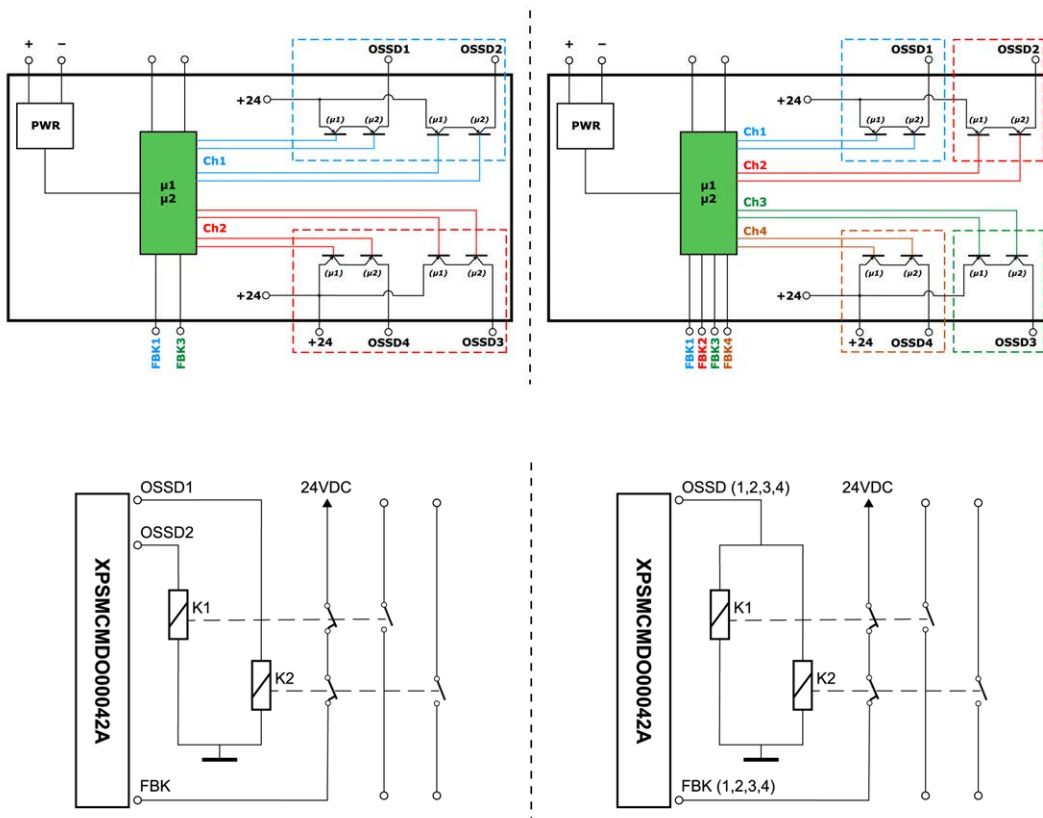

Dual channel OSSD configuration with 2 dual channel outputs, safety category SIL3/PL e: EN 61508:2010

Single channel OSSD configuration with 4 single outputs, safety category SIL3/PL e: EN 61508:2010

Category 3 wiring for XPSMCMDO00042A:

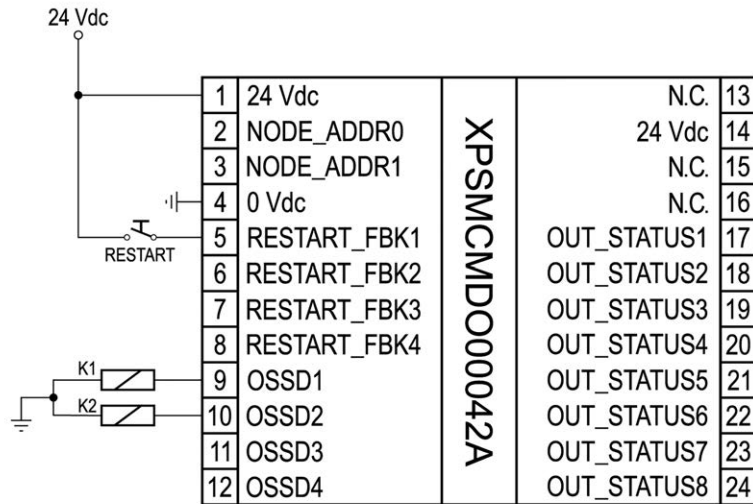

**NOTE:** Best practice dictates the use of fusing on the incoming 24 Vdc power, and sized appropriately for the requirements of the module.

<b>⚠ WARNING</b>	
<b>UNINTENDED EQUIPMENT OPERATION</b>	
Do not connect wires to unused terminals and/or terminals indicated as "No Connection (N.C.)" or Not Connected.	
<b>Failure to follow these instructions can result in death, serious injury, or equipment damage.</b>	

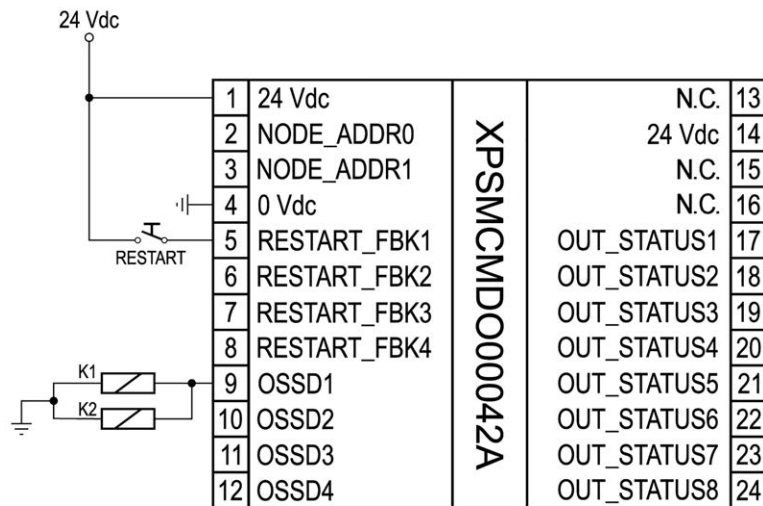

**NOTE:** Best practice dictates the use of fusing on the incoming 24 Vdc power, and sized appropriately for the requirements of the module.

<b>⚠ WARNING</b>	
<b>UNINTENDED EQUIPMENT OPERATION</b>	
Do not connect wires to unused terminals and/or terminals indicated as "No Connection (N.C.)" or Not Connected.	
<b>Failure to follow these instructions can result in death, serious injury, or equipment damage.</b>	

Category 4 wiring for XPSMCMDO00042A(G) with feedback of the contactors K1 and K2:

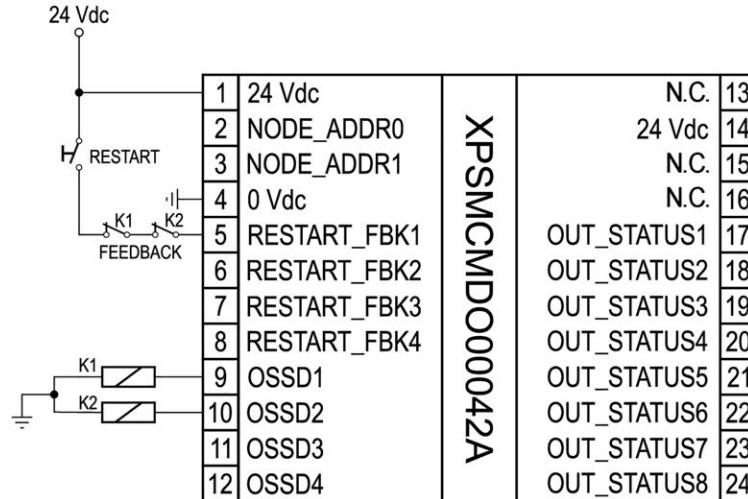

**NOTE:** Best practice dictates the use of fusing on the incoming 24 Vdc power, and sized appropriately for the requirements of the module.

<b>⚠ WARNING</b>
<b>UNINTENDED EQUIPMENT OPERATION</b>
Do not connect wires to unused terminals and/or terminals indicated as "No Connection (N.C.)" or Not Connected.
<b>Failure to follow these instructions can result in death, serious injury, or equipment damage.</b>

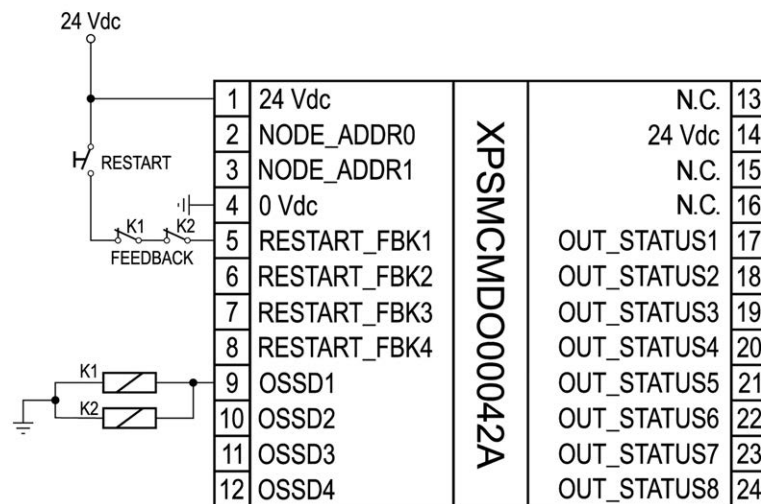

**NOTE:** Best practice dictates the use of fusing on the incoming 24 Vdc power, and sized appropriately for the requirements of the module.

<b>⚠ WARNING</b>
<b>UNINTENDED EQUIPMENT OPERATION</b>
Do not connect wires to unused terminals and/or terminals indicated as "No Connection (N.C.)" or Not Connected.
<b>Failure to follow these instructions can result in death, serious injury, or equipment damage.</b>

# LED Indicators

## Front-Face View

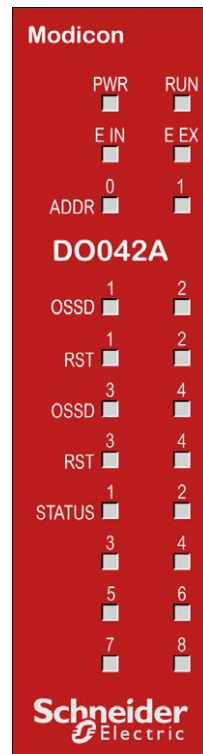

## Operation States

The following table describes the indication of operation states of the XPSMCMDO00042A(G) by means of the LEDs. The description assumes that the power LED (**PWR**) is ON:

RUN green	E IN red	E EX red	ADDR 0...1 orange	OSSD 1...4 red/ green	RST 1...4 yellow	STA-TUS 1...8 yellow	Meaning
ON	ON	ON	ON	Red	ON	ON	Power on - initial test
OFF = awaiting initialization	OFF	OFF	Encoded Node address, page 92	Red = output OFF  Green = output ON	ON = waiting for restart  Flashes = no feed-back	Reflect status output state	Normal operation
Flashes = no inputs or outputs configured							
ON = inputs or outputs configured							

## Troubleshooting

The following table describes the indication of detected errors of the XPSMCMDO00042A(G) by means of the LEDs. The description assumes that the power LED (**PWR**) is ON:

Detected error	RUN green	E IN red	E EX red	AD-DR orange	OSSD 1...4 red/green	RST 1...4 yellow	STATUS 1...4 yellow	Solution
Internal error detected	OFF	2 or 3 flashes	OFF	En-coded Node address, page 92	Red	OFF	OFF	Product non serviceable <sup>(1)</sup> .
Compatibility error detected	OFF	5 flashes	OFF		5 flashes	5 flashes	5 flashes	Firmware version not compatible with controller <sup>(1)</sup> .
OSSD output error detected	OFF	4 flashes periodically repeated	OFF		4 flashes (only corresponding LED)	OFF	OFF	Product non serviceable <sup>(1)</sup> .
Error in communication with controller detected	OFF	5 flashes	OFF		OFF	OFF	OFF	Restart the system <sup>(1)</sup> .
Expansion module or controller error detected	OFF	ON	OFF		OFF	OFF	OFF	Restart the system.  Identify the expansion module affected by this condition and consult its user guide.
Two units of the same module reference with the same node address detected	OFF	5 flashes	5 flashes		OFF	OFF	OFF	Modify the unit node address, page 92.
Short circuit or overload detected on status output	ON	OFF	ON		En-coded Node address, page 92	Output state	OFF	Flashes
Overload on OSSD / OSSD load connected to 24 Vdc detected	ON	OFF	ON		Flashing red (only corresponding LED)	OFF	Status output state	Verify correct wiring of the safety-related outputs (OSSD) <sup>(1)</sup> .
No power supply detected on OSSD3, OSSD4 output	ON	OFF	ON		Flashing red (OUT 3,4)	Flashing (RST 3,4)	Status output state	Connect pin 14 to power supply.
Node detection circuit error detected.	OFF	3 flashes	OFF	3 flashes	OFF	OFF	OFF	Product non serviceable <sup>(1)</sup> .

(1) If the condition persists, contact your local Schneider Electric representative.

# Module Characteristics

## Presentation

Module-specific characteristics	
Description	Electronic housing maximum 24 poles, with locking latch mounting
Mounting	DIN rail mounting with locking latch
Restart Input	4 /  EDM (External Device Monitoring) input type 3 according to EN 61131-2. Maximum resistance 1.2 kΩ. Possible automatic restart function or manual operation with restart pushbutton.
Status outputs	8 /  SIL 1/PL c in accordance with standard EN 61508:2010. Maximum current per output: 100 mA, nominal voltage 24 Vdc.
Solid-state safety-related output (OSSD)	4 / solid-state safety-related outputs PNP active high <ul style="list-style-type: none"> <li>• Interface type C class 3 (ZVEI CB24I Ed.2)</li> <li>• The outputs are able to supply:                             <ul style="list-style-type: none"> <li>◦ In the ON condition: <math>U_v - 0.6 V \dots U_v</math> where <math>U_v = 24 V_{dc} \pm 20\%</math></li> <li>◦ In the OFF condition: 0...2 Vrms (root mean square)</li> </ul> </li> <li>• The maximum load current of 2 A at 24 Vdc (each OSSD) corresponds to a minimum resistive load of 12 Ω.                             <ul style="list-style-type: none"> <li>◦ The maximum capacitive load is 0.82 μF.</li> <li>◦ The maximum inductive load is 2.4 mH.</li> </ul> </li> <li>• Test pulses are used to detect short circuits and interruptions of wires. The switch-off test pulse interval is every 600 ms, the maximum test pulse duration is 120 μs.</li> </ul>
Probability of a Dangerous Failure per Hour (PFHd)	8,56E-09
Mean Time to Dangerous Failure (MTTFd) in years	395
Connection to expansion modules	5-way backplane expansion
Weight	0.150 kg (5.29 oz)

**NOTE:** For the characteristics common to all modules, refer to General Characteristics, page 24.

**⚠ DANGER**

**FIRE HAZARD**

Use only the correct wire sizes for the maximum current capacity of the I/O channels and power supplies.

**Failure to follow these instructions will result in death or serious injury.**

**⚠ WARNING**

**UNINTENDED EQUIPMENT OPERATION**

Do not exceed any of the rated values specified in the characteristics tables.

**Failure to follow these instructions can result in death, serious injury, or equipment damage.**

To achieve Performance Level PL e, according to standard EN 13849-1, the OSSD safety-related outputs must be independent.

Reduce Common Cause Failures (CCF) of OSSD safety-related outputs by separating cable paths (refer to ISO 13849-2 for event exclusion).

**⚠ WARNING****UNINTENDED EQUIPMENT OPERATION**

Run single channel, dual wiring in separate cabling.

**Failure to follow these instructions can result in death, serious injury, or equipment damage.**

## XPSMCMDO0004S(G) Output Expansion Module

### Module and Functional Description

#### Presentation

The XPSMCMDO0004S(G) is an output expansion module. The XPSMCMDO0004S(G) module can only be configured with the XPSMCMC10804(G) or XPSMCMC10804E(G) Modular Safety Controller.

The XPSMCMDO0004S(G) module provides four solid-state safety-related outputs which can be used as four single or two dual (Output Signal Switching Device, OSSD) and four SIL 1/PL c status outputs.

The expansion module supports two inputs `NODE_ADDR0` and `NODE_ADDR1` which are used to set a physical address to the module:

	<b>NODE_ADDR0 (Terminal 2)</b>	<b>NODE_ADDR1 (Terminal 3)</b>
NODE 0	0 (or not connected)	0 (or not connected)
NODE 1	24 Vdc	0 (or not connected)
NODE 2	0 (or not connected)	24 Vdc
NODE 3	24 Vdc	24 Vdc

**NOTE:** Do not use the same physical address for two units of the same module reference.  
**NOTE:** The LEDs **ADDR 1** and **ADDR 0** correspond to the `NODE_ADDR1` and `NODE_ADDR0` in this table respectively.  
**NOTE:** The node address wiring must match the configuration settings.

#### Input RESTART (RST)

For more information, refer to the description of the Input RESTART of the XPSMCMC10804(G), page 44.

#### Output STATUS (SIL 1/PL c in Accordance with Standard EN 61508:2010)

The status outputs are configurable digital diagnostic outputs that indicate the status of safety-related inputs and/or outputs.

For more information, refer to the description of the Output STATUS of the XPSMCMC10804(G), page 45.

#### Solid-State Safety-Related Output (OSSD)

For more information, refer to the description of the Solid-State safety-related output (OSSD) of the XPSMCMC10804(G), page 46.

## Connector Designations and Sample Wiring Diagrams

### XPSMCMDO0004S(G) Module Safety Connector Designations

Terminal	Signal	LED	Type	Description	Operation
1	24 VDC	PWR	-	24 Vdc power supply	-
2	NODE_ADDR0	ADDR0	Input	Node selection	Input type 3 according to EN 61131-2. Maximum resistance 1.2 kΩ.
3	NODE_ADDR0	ADDR1			
4	0 VDC	PWR	-	0 Vdc power supply	-
5	OSSD1	OSSD 1	Output	Safety-related output 1	PNP active at Uv (24 Vdc ± 20%).
6	OSSD2	OSSD 2	Output	Safety-related output 2	
7	RESTART_FBK1 / STATUS1	STATUS 1	Input / Output	Feedback/restart 1 for OSSD1	Input type 3 according to EN 61131-2. Maximum resistance 1.2 kΩ.
				Configurable output 1 for OSSD1	Configurable output (SIL 1/PL c in accordance with EN 61508:2010)
8	RESTART_FBK2 / STATUS2	STATUS 2	Input / Output	Feedback/restart 2 for OSSD2	Input type 3 according to EN 61131-2. Maximum resistance 1.2 kΩ.
				Configurable output 2 for OSSD2	Configurable output (SIL 1/PL c in accordance with EN 61508:2010)
9	OSSD3	OSSD 3	Output	Safety-related output 3	PNP active at Uv (24 Vdc ± 20%).
10	OSSD4	OSSD 4	Output	Safety-related output 4	
11	RESTART_FBK3 / STATUS3	STATUS 3	Input / Output	Feedback/restart 3 for OSSD3	Input type 3 according to EN 61131-2. Maximum resistance 1.2 kΩ.
				Configurable output 3 for OSSD3	Configurable output (SIL 1/PL c in accordance with EN 61508:2010)
12	RESTART_FBK4 / STATUS4	STATUS 4	Input / Output	Feedback/restart 4 for OSSD4	Input type 3 according to EN 61131-2. Maximum resistance 1.2 kΩ.
				Configurable output 4 for OSSD4	Configurable output (SIL 1/PL c in accordance with EN 61508:2010)

## XPSMCMDO0004S(G) Sample Wiring Diagrams

Category 3 wiring for XPSMCMDO0004S(G):

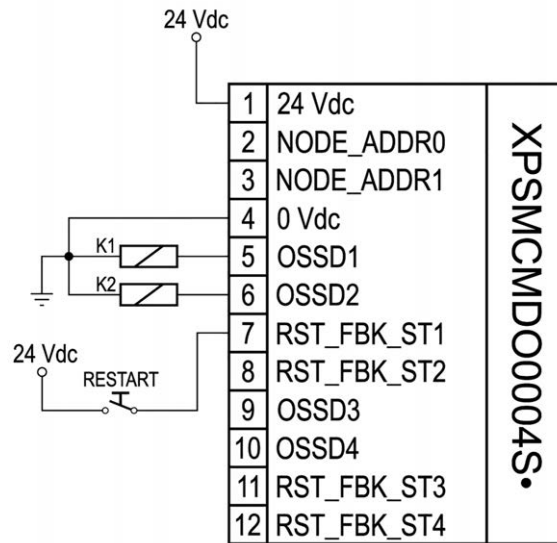

**NOTE:** Best practice dictates the use of fusing on the incoming 24 Vdc power, and sized appropriately for the requirements of the module.

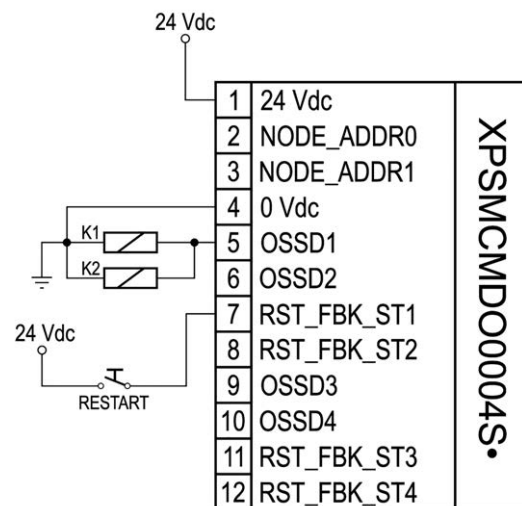

**NOTE:** Best practice dictates the use of fusing on the incoming 24 Vdc power, and sized appropriately for the requirements of the module.

Category 4 wiring for XPSMCMDO0004S(G) with feedback of the contactors K1 and K2:

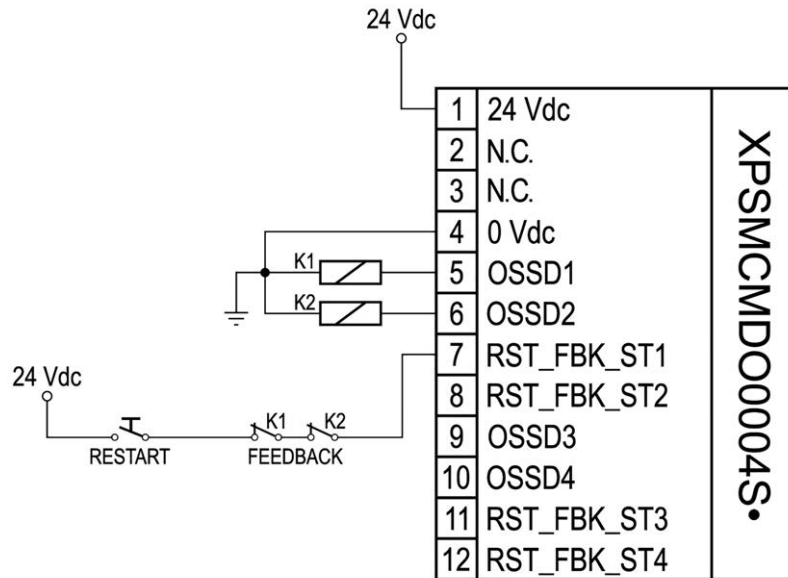

**NOTE:** Best practice dictates the use of fusing on the incoming 24 Vdc power, and sized appropriately for the requirements of the module.

## ⚠ WARNING

**UNINTENDED EQUIPMENT OPERATION**

Do not connect wires to unused terminals and/or terminals indicated as "No Connection (N.C.)" or Not Connected.

**Failure to follow these instructions can result in death, serious injury, or equipment damage.**

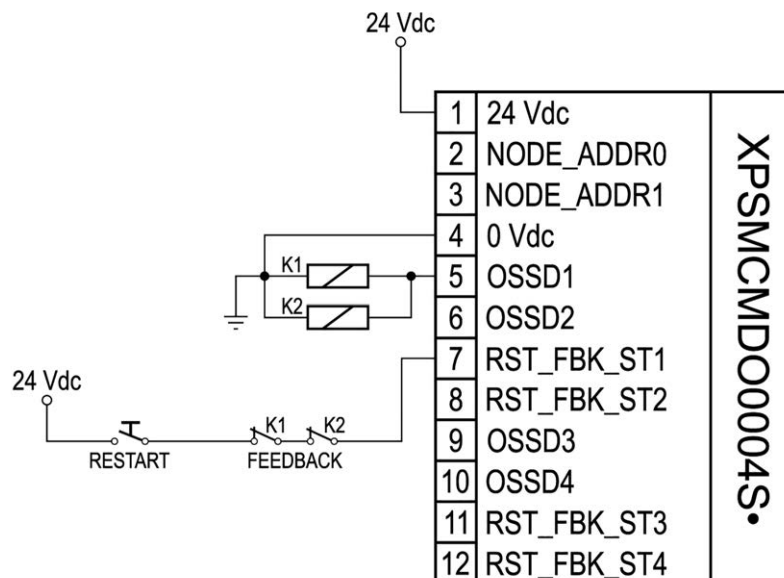

**NOTE:** Best practice dictates the use of fusing on the incoming 24 Vdc power, and sized appropriately for the requirements of the module.

## LED Indicators

### Front-Face View



## Operation States

The following table describes the indication of operation states of the XPSMCMDO0004S(G) by means of the LEDs. The description assumes that the power LED (**PWR**) is ON:

<b>RUN</b> green	<b>E IN</b> red	<b>E EX</b> red	<b>ADDR 0...1</b> orange	<b>OSSD 1...4</b> red/ green/ yellow	<b>RST_FBK/ STATUS 1...4</b> yellow	<b>Meaning</b>
ON	ON	ON	ON	Red	ON	Power on - initial test
OFF = awaiting initialization	OFF	OFF	Encoded Node address, page 100	Red = output OFF	Reflect status output state	Normal operation
Flashes = no inputs or outputs configured				Green = output ON		
ON = inputs or outputs configured				Yellow = waiting for restart		
				Flashing yellow = no feedback		

## Troubleshooting

The following table describes the indication of detected errors of the XPSMCMDO0004S(G) by means of the LEDs. The description assumes that the power LED (**PWR**) is ON:

Detected error	RUN green	E IN red	E EX red	ADDR 0...1 orange	OSSD 1...4 red / green / yellow	RST_FBK/ STATUS 1...4 yellow	Solution
Internal error detected	OFF	2 or 3 flashes periodically repeated	OFF	Encoded Node address, page 100	Red	OFF	Product non serviceable <sup>(1)</sup> .
Compatibility error detected	OFF	5 flashes	OFF		5 flashes	5 flashes	Firmware version not compatible with controller <sup>(1)</sup> .
OSSD output error detected	OFF	4 flashes	OFF		4 flashes (only corresponding LED)	OFF	Verify correct wiring of the safety-related outputs (OSSD) <sup>(1)</sup> .
Error in communication with controller detected	OFF	5 flashes	OFF		OFF	OFF	Restart the system <sup>(1)</sup> .
Expansion module or controller error detected	OFF	ON	OFF		OFF	OFF	Restart the system. Identify the expansion module affected by this condition and consult its user guide <sup>(1)</sup> .
Two units of the same module reference with the same node address detected	OFF	5 flashes	5 flashes		OFF	OFF	Modify the unit node address, page 100.
Overload on OSSD / OSSD load connected to 24 Vdc detected	ON	OFF	ON	Encoded Node address, page 100	Flashing red (only corresponding LED)	Reflect status output state	Verify correct wiring of the safety-related outputs (OSSD) <sup>(1)</sup> .
Short circuit or overload detected on status output	ON	OFF	ON		Output state	Flashing	Verify correct wiring of STATUS output <sup>(1)</sup> .

**(1)** If the condition persists, contact your local Schneider Electric representative.

## Module Characteristics

### Presentation

Module-specific characteristics	
Description	Electronic housing maximum 12-poles, with locking latch mounting
Mounting	DIN rail mounting with locking latch
Restart input (optional to status outputs) (number / description)	4 / EDM (External Device Monitoring) type 3 according to EN 61131-2. Maximum resistance 1.2 kΩ. Possible automatic restart function or manual operation with restart pushbutton.
Status outputs (optional to restart input) (number / description)	4 / SIL 1/PL c in accordance with standard EN 61508:2010. Maximum current per output: 100 mA, nominal voltage 24 Vdc.

Module-specific characteristics	
Solid-state safety-related output (OSSD)	4 / solid-state safety-related outputs PNP active high <ul style="list-style-type: none"> <li>• Interface type C class 3 (ZVEI CB24I Ed.2)</li> <li>• The outputs are able to supply:               <ul style="list-style-type: none"> <li>◦ In the ON condition: <math>U_v - 0.6 V \dots U_v</math> where <math>U_v = 24 V_{dc} \pm 20\%</math></li> <li>◦ In the OFF condition: <math>0 \dots 2 V_{rms}</math> (root mean square)</li> </ul> </li> <li>• The maximum load current of 400 mA (per OSSD) corresponds to a minimum resistive load of <math>60 \Omega</math>.               <ul style="list-style-type: none"> <li>◦ The maximum capacitive load is <math>0.82 \mu F</math>.</li> <li>◦ The maximum inductive load is 2 mH.</li> </ul> </li> <li>• Test pulses are used to detect short circuits and interruptions of wires. The switch-off test pulse interval is every 600 ms, the maximum test pulse duration is 120 <math>\mu s</math>.</li> </ul>
Probability of a Dangerous Failure per Hour (PFHd)	1.20E-08
Mean Time to Dangerous Failure (MTTFd) in years	238
Connection to expansion modules	5-way backplane expansion
Weight	0.138 kg (4.86 oz)

**NOTE:** For the characteristics common to all modules, refer to General Characteristics, page 24.

## ⚠ DANGER

### FIRE HAZARD

Use only the correct wire sizes for the maximum current capacity of the I/O channels and power supplies.

**Failure to follow these instructions will result in death or serious injury.**

## ⚠ WARNING

### UNINTENDED EQUIPMENT OPERATION

Do not exceed any of the rated values specified in the characteristics tables.

**Failure to follow these instructions can result in death, serious injury, or equipment damage.**

To achieve Performance Level PL e, according to standard EN 13849-1, the OSSD safety-related outputs must be independent.

Reduce Common Cause Failures (CCF) of OSSD safety-related outputs by separating cable paths (refer to ISO 13849-2 for event exclusion).

## ⚠ WARNING

### UNINTENDED EQUIPMENT OPERATION

Run single channel, dual wiring in separate cabling.

**Failure to follow these instructions can result in death, serious injury, or equipment damage.**

# XPSMCMDO0008C1(G) Output Expansion Module

## Module and Functional Description

### Presentation

The XPSMCMDO0008C1(G) is an output expansion module for the XPSMCM• Modular Safety Controller. The XPSMCMDO0008C1(G) module provides 8 SIL 1/PL c outputs.

The expansion module supports two inputs `NODE_ADDR0` and `NODE_ADDR1` which are used to set a physical address to the module:

	<b>NODE_ADDR0 (Terminal 2)</b>	<b>NODE_ADDR1 (Terminal 3)</b>
NODE 0	0 (or not connected)	0 (or not connected)
NODE 1	24 Vdc	0 (or not connected)
NODE 2	0 (or not connected)	24 Vdc
NODE 3	24 Vdc	24 Vdc

**NOTE:** Do not use the same physical address for two units of the same module reference.

**NOTE:** The LEDs **ADDR 1** and **ADDR 0** correspond to the `NODE_ADDR1` and `NODE_ADDR0` in this table respectively.

**NOTE:** The node address wiring must match the configuration settings.

## Output STATUS (SIL 1/PL c in Accordance with Standard EN 61508:2010)

The status outputs are configurable digital diagnostic outputs that indicate the status of safety-related inputs and/or outputs.

The XPSMCMDO0008C1(G) module provides 8 SIL 1/PL c outputs.

The status outputs are SIL 1/PL c outputs configurable by means of SoSafe Configurable.

⚠ WARNING

**INSUFFICIENT SAFETY-RELATED FUNCTIONS**

Do not use status outputs for safety-related purposes greater than SIL 1/PL c (EN 61508:2010).

**Failure to follow these instructions can result in death, serious injury, or equipment damage.**

**NOTE:** To ensure the correct operation of the status outputs 1 to 8, you must connect terminal 5 to power supply (24 Vdc ± 20%).

## Connector Designations and Sample Wiring Diagrams

### XPSMCMDO0008C1(G) Module Connector Designations

Terminal	Signal	LED	Type	Description	Operation
1	24 VDC	PWR	-	24 Vdc power supply	-
2	NODE_ADDR0	ADDR0	Input	Node selection	Input type 3 according to EN 61131-2.
3	NODE_ADDR1	ADDR1			

Terminal	Signal	LED	Type	Description	Operation
					Maximum resistance 1.2 kΩ.
4	0 VDC	PWR	-	0 Vdc power supply	-
5	OUT_STATUS 1/8 24 VDC	PWR	-	24 Vdc power supply	-
6	-	-	-	-	-
7	-	-	-	-	-
8	-	-	-	-	-
9	OUT_STATUS 1	STATUS 1	Out-put	Configurable output 1	Configurable output (SIL 1/PL c in accordance with EN 61508:2010)
10	OUT_STATUS 2	STATUS 2		Configurable output 2	
11	OUT_STATUS 3	STATUS 3		Configurable output 3	
12	OUT_STATUS 4	STATUS 4		Configurable output 4	
13	OUT_STATUS 5	STATUS 5		Configurable output 5	
14	OUT_STATUS 6	STATUS 6		Configurable output 6	
15	OUT_STATUS 7	STATUS 7		Configurable output 7	
16	OUT_STATUS 8	STATUS 8		Configurable output 8	

### XPSMCMDO0008C1(G) Sample Wiring Diagram

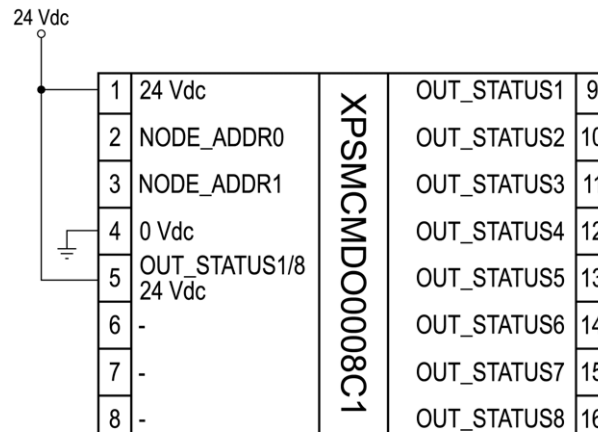

**NOTE:** Best practice dictates the use of fusing on the incoming 24 Vdc power, and sized appropriately for the requirements of the module.

# LED Indicators

## Front-Face View

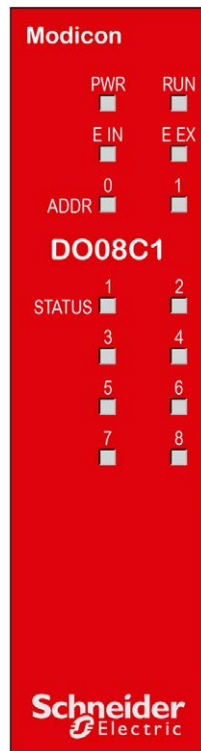

## Operation States

The following table describes the indication of operation states of the XPSMCMDO0008C1(G) by means of the LEDs. The description assumes that the power LED (**PWR**) is ON:

<b>RUN</b> green	<b>E IN</b> red	<b>E EX</b> red	<b>ADDR 0...1</b> orange	<b>STATUS 1...8</b> yellow	<b>Meaning</b>
ON	ON	ON	ON	ON	Power on - initial test
OFF = awaiting initialization	OFF	OFF	Encoded Node address, page 107	Reflect status output state	Normal operation
Flashing = no inputs or outputs configured					
ON = inputs or outputs configured					

## Troubleshooting

The following table describes the indication of detected errors of the XPSMCMDO0008C1(G) by means of the LEDs. The description assumes that the power LED (**PWR**) is ON:

Detected error	RUN green	E IN red	E EX red	ADDR 0...1 or- ange	STATUS 1...8 yellow	Solution
Internal error detected.	OFF	2 or 3 flashes	OFF	Enco- ded Node ad- dress, page 107	OFF	Product non serviceable <sup>(1)</sup> .
Compatibility error detected.	OFF	5 flashes	OFF		5 flashes	Firmware version not compatible with controller <sup>(1)</sup> .
Error in communication with controller detected.	OFF	5 flashes	OFF		OFF	Restart the system <sup>(1)</sup> .
Error on other expansion module or controller detected.	OFF	ON	OFF		OFF	Restart the system. Identify the expansion module affected by this condition and consult its user guide <sup>(1)</sup> .
Two units of the same module reference with the same node address detected	OFF	5 flashes	5 flashes		OFF	Modify the unit node address, page 107.
Error detected on node detection circuit error detected.	OFF	3 flashes	OFF	3 flashes	OFF	Product non serviceable <sup>(1)</sup> .
Short circuit or overload detected on STATUS 1-8 output.	OFF	OFF	ON	OFF	Flashes	Verify correct wiring of status output <sup>(1)</sup> .
No power supply detected on STATUS 1-8 output.	OFF	OFF	ON	OFF	Flashes (STATUS 1,3,5,7 and 2,4,6,8 alternatively)	Connect pin 5 to power supply.

**(1)** If the condition persists, contact your local Schneider Electric representative.

## Module Characteristics

### Presentation

Module-specific characteristics	XPSMCMDO0008C1(G)
Description	Electronic housing maximum 16 poles, with locking latch mounting
Mounting	DIN rail mounting with locking latch
Status outputs	8 / SIL 1/PL c in accordance with standard EN 61508:2010. Maximum current per output: 100 mA, nominal voltage 24 Vdc.
Probability of a Dangerous Failure per Hour (PFHd)	4.44E-09
Mean Time to Dangerous Failure (MTTFd) in years	985
Connection to expansion modules	5-way backplane expansion
Weight	0.13 kg (4.6 oz)

**NOTE:** For the characteristics common to all modules, refer to General Characteristics, page 24.

**⚠ DANGER**

**FIRE HAZARD**

Use only the correct wire sizes for the maximum current capacity of the I/O channels and power supplies.

**Failure to follow these instructions will result in death or serious injury.**

**⚠ WARNING**

**UNINTENDED EQUIPMENT OPERATION**

Do not exceed any of the rated values specified in the characteristics tables.

**Failure to follow these instructions can result in death, serious injury, or equipment damage.**

## XPSMCMDO0016C1(G) Output Expansion Module

### Module and Functional Description

#### Presentation

The XPSMCMDO0016C1(G) is an output expansion module for the XPSMCM• Modular Safety Controller. The XPSMCMDO0016C1(G) module provides 16 SIL 1/PL c outputs.

The expansion module supports two inputs `NODE_ADDR0` and `NODE_ADDR1` which are used to set a physical address to the module:

	NODE_ADDR0 (Terminal 2)	NODE_ADDR1 (Terminal 3)
NODE 0	0 (or not connected)	0 (or not connected)
NODE 1	24 Vdc	0 (or not connected)
NODE 2	0 (or not connected)	24 Vdc
NODE 3	24 Vdc	24 Vdc

**NOTE:** Do not use the same physical address for two units of the same module reference.

**NOTE:** The LEDs **ADDR 1** and **ADDR 0** correspond to the `NODE_ADDR1` and `NODE_ADDR0` in this table respectively.

**NOTE:** The node address wiring must match the configuration settings.

### Output STATUS (SIL 1/PL c in Accordance with Standard EN 61508:2010)

The status outputs are configurable digital diagnostic outputs that indicate the status of safety-related inputs and/or outputs.

The XPSMCMDO0016C1(G) module provides 16 SIL 1/PL c outputs.

The status outputs are SIL 1/PL c outputs configurable by means of SoSafe Configurable.

**⚠ WARNING****INSUFFICIENT SAFETY-RELATED FUNCTIONS**

Do not use status outputs for safety-related purposes greater than SIL 1/PL c (EN 61508:2010).

**Failure to follow these instructions can result in death, serious injury, or equipment damage.**

**NOTE:** To ensure the correct operation of the status outputs 1 to 16, you must connect terminals 5 and 6 to power supply (24 Vdc  $\pm$  20%).

## Connector Designations and Sample Wiring Diagrams

### XPSMCMD0016C1(G) Module Connector Designations

Terminal	Signal	LED	Type	Description	Operation
1	24 VDC	PWR	-	24 Vdc power supply	-
2	NODE_ADDR0	ADDR0	Input	Node selection	Input type 3 according to EN 61131-2. Maximum resistance 1.2 k $\Omega$ .
3	NODE_ADDR1	ADDR1			
4	0 VDC	PWR	-	0 Vdc power supply	-
5	OUT_STATUS 1/8 24 VDC	PWR	-	24 Vdc power supply	-
6	OUT_STATUS 9/16 24 VDC	PWR	-	24 Vdc power supply	-
7	-	-	-	-	-
8	-	-	-	-	-
9	OUT_STATUS 1	STATUS 1	Output	Configurable output 1	Configurable output (SIL 1/PL c in accordance with EN 61508:2010)
10	OUT_STATUS 2	STATUS 2		Configurable output 2	
11	OUT_STATUS 3	STATUS 3		Configurable output 3	
12	OUT_STATUS 4	STATUS 4		Configurable output 4	
13	OUT_STATUS 5	STATUS 5		Configurable output 5	
14	OUT_STATUS 6	STATUS 6		Configurable output 6	
15	OUT_STATUS 7	STATUS 7		Configurable output 7	
16	OUT_STATUS 8	STATUS 8		Configurable output 8	
17	OUT_STATUS 9	STATUS 9	Output	Configurable output 9	Configurable output (SIL 1/PL c in accordance with EN 61508:2010)
18	OUT_STATUS 10	STATUS 10		Configurable output 10	
19	OUT_STATUS 11	STATUS 11		Configurable output 11	
20	OUT_STATUS 12	STATUS 12		Configurable output 12	

Terminal	Signal	LED	Type	Description	Operation
21	OUT_STATUS 13	STATUS 13		Configurable output 13	
22	OUT_STATUS 14	STATUS 14		Configurable output 14	
23	OUT_STATUS 15	STATUS 15		Configurable output 15	
24	OUT_STATUS 16	STATUS 16		Configurable output 16	

## XPSMCMDO0016C1(G) Module Sample Wiring Diagram

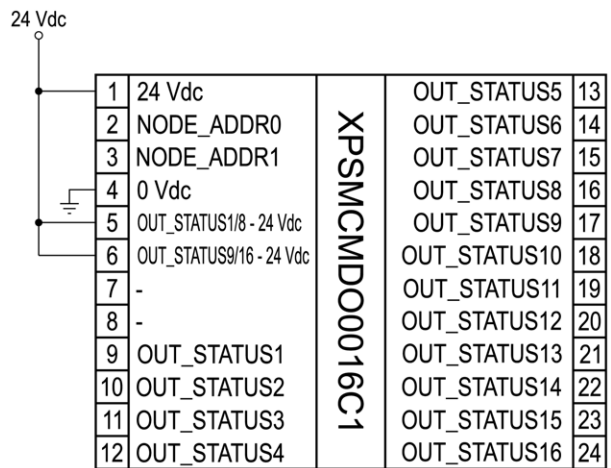

**NOTE:** Best practice dictates the use of fusing on the incoming 24 Vdc power, and sized appropriately for the requirements of the module.

## LED Indicators

### Front-Face View

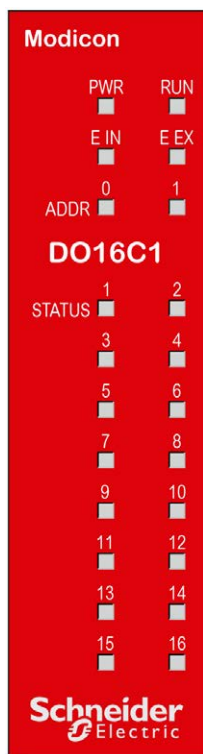

## Operation States

The following table describes the indication of operation states of the XPSMCMDO0016C1(G) by means of the LEDs. The description assumes that the power LED (**PWR**) is ON:

<b>RUN</b> green	<b>E IN</b> red	<b>E EX</b> red	<b>ADDR 0...1</b> orange	<b>STATUS 1...16</b> yellow	<b>Meaning</b>
ON	ON	ON	ON	ON	Power on - initial test
OFF = awaiting initialization	OFF	OFF	Encoded Node address, page 111	Reflect status output state	Normal operation
Flashing = no inputs or outputs configured					
ON = inputs or outputs configured					

## Troubleshooting

The following table describes the indication of detected errors of the XPSMCMDO0016C1(G) by means of the LEDs. The description assumes that the power LED (**PWR**) is ON:

Detected error	RUN green	E IN red	E EX red	ADDR 0...1 orange	STATUS 1...8 yellow	STATUS 9...16 yellow	Solution
Internal error detected.	OFF	2 or 3 flashes	OFF	Encoded Node address, page 111	OFF	OFF	Product non serviceable <sup>(1)</sup> .
Compatibility error detected.	OFF	5 flashes	OFF		5 flashes	5 flashes	Firmware version not compatible with controller <sup>(1)</sup> .
Error in communication with controller detected.	OFF	5 flashes	OFF		OFF	OFF	Restart the system <sup>(1)</sup> .
Error on other expansion module or in the controller detected.	OFF	ON	OFF		OFF	OFF	Restart the system. Identify the expansion module affected by this condition and consult its user guide <sup>(1)</sup> .
Two units of the same module reference with the same node address detected	OFF	5 flashes	5 flashes		OFF	OFF	Modify the unit node address, page 111.
Error detected on node detection circuit error detected.	OFF	3 flashes	OFF	3 flashes	OFF	OFF	Product non serviceable <sup>(1)</sup> .
Short circuit or overload detected on STATUS 1-8 output.	OFF	OFF	ON	OFF	Flashes	OFF	Verify correct wiring of status output <sup>(1)</sup> .
Short circuit or overload detected on STATUS 9-16 output.	OFF	OFF	ON	OFF	OFF	Flashes	Verify correct wiring of status output <sup>(1)</sup> .
No power supply detected on STATUS 1-8 output.	OFF	OFF	ON	OFF	Flashes (STATUS 1,3,5,7 and 2,4,6,8 alternatively)	OFF	Connect pin 5 to power supply.
No power supply detected on STATUS 9-16 output.	OFF	OFF	ON	OFF	OFF	Flashes (STATUS 9,11,13,15 and 10,12,14,16 alternatively)	Connect pin 6 to power supply.

(1) If the condition persists, contact your local Schneider Electric representative.

## Module Characteristics

### Presentation

Module-specific characteristics	XPSMCMDO0016C1(G)
Description	Electronic housing maximum 24 poles, with locking latch mounting
Mounting	DIN rail mounting with locking latch
Status outputs	16 / SIL 1/PL c in accordance with standard EN 61508:2010. Maximum current per output: 100 mA, nominal voltage 24 Vdc.
Probability of a Dangerous Failure per Hour (PFHd)	6.61E-09

<b>Module-specific characteristics</b>	<b>XPSMCMDO0016C1(G)</b>
Mean Time to Dangerous Failure (MTTFd) in years	772
Connection to expansion modules	5-way backplane expansion
Weight	0.145 kg (5.11 oz)

**NOTE:** For the characteristics common to all modules, refer to General Characteristics, page 24.

## ⚠ DANGER

### FIRE HAZARD

Use only the correct wire sizes for the maximum current capacity of the I/O channels and power supplies.

**Failure to follow these instructions will result in death or serious injury.**

## ⚠ WARNING

### UNINTENDED EQUIPMENT OPERATION

Do not exceed any of the rated values specified in the characteristics tables.

**Failure to follow these instructions can result in death, serious injury, or equipment damage.**

## XPSMCMER00••(G) Output Expansion Modules

### Module and Functional Description

#### Presentation

The XPSMCMER0002(G), XPSMCMER0004(G) and XPSMCMER0008(G) are output expansion modules and are configured with the XPSMCM• Modular Safety Controller.

The XPSMCMER0002(G) module provides one Category 4 safety-related relay output (2 NO contacts and 1 NC contact). The XPSMCMER0004(G) module provides two Category 4 safety-related relay outputs (2 x 2 NO contacts and 1 NC contact). The XPSMCMER0008(G) module provides four Category 4 safety related relay outputs (4 x 2 NO contacts and 1 NC contact). Digital outputs from the XPSMCM• Modular Safety Controller or digital expansion modules with OSSD outputs are physically wired to the inputs of the XPSMCMER00••(G) module. The XPSMCMER00••(G) modules are not connected to the backplane expansion.

# Connector Designations, Sample Wiring Diagram and Dimensions

## Terminals

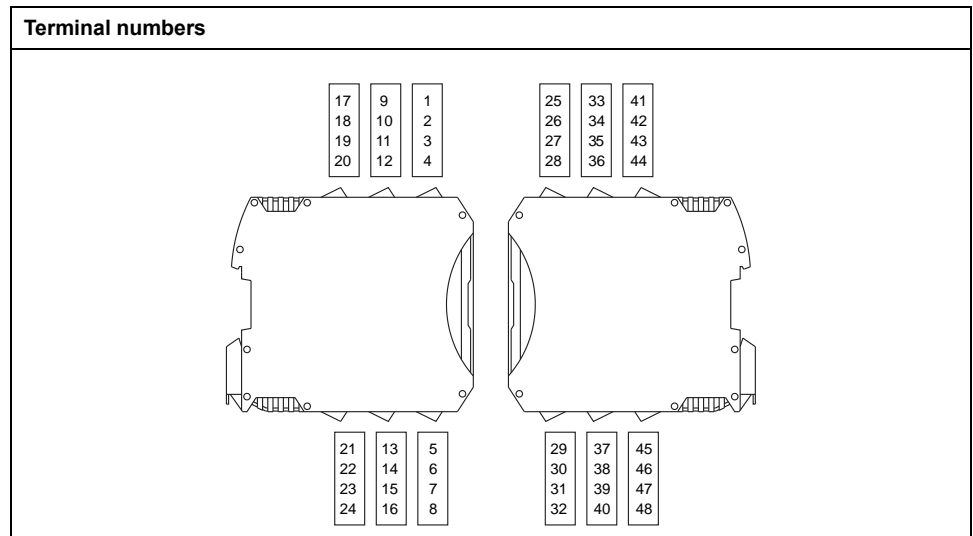

## XPSMCMER002(G) Module Connector Designations

Terminal	Signal	LED	Type	Description	Operation
1	24 VDC	–	–	24 Vdc power supply	–
4	0 VDC	–	–	0 Vdc power supply	–
5	OSSD1_A	–	Input	Control relay input 1	Input type 3. Maximum applicable resistance 1.2 kΩ.
6	OSSD1_B	–			
7	FBK_K1_K2_1	–	Output	Feedback relay output 1	–
9	A_NC1	RELAY 1		NC contact relay output 1	
10	B_NC1				
13	A_NO11			NO contact 1 relay output 1	
14	B_NO11				
15	A_NO12			NO contact 2 relay output 1	
16	B_NO12				

## XPSMCMER004(G) Module Connector Designations

Terminal	Signal	LED	Type	Description	Operation
1	24 VDC	–	–	24 Vdc power supply	–
4	0 VDC	–	–	0 Vdc power supply	–
5	OSSD1_A	–	Input	Control relay input 1	Input type 3. Maximum applicable resistance 1.2 kΩ.
6	OSSD1_B	–			
7	FBK_K1_K2_1	–	Output	Feedback relay output 1	–
9	A_NC1	RELAY 1	Output	NC contact relay output 1	–
10	B_NC1				

Terminal	Signal	LED	Type	Description	Operation
13	A_NO11	RELAY 1	Output	NO contact 1 relay output 1	-
14	B_NO11				
15	A_NO12			NO contact 2 relay output 1	
16	B_NO12				
17	OSSD2_A	-	Input	Control relay input 2	Input type 3. Maximum applicable resistance 1.2 kΩ.
18	OSSD2_B				
19	FBK_K1_K2_2	-	Output	Feedback relay output 1	-
11	A_NC2	RELAY 2	Output	NC contact relay output 2	-
12	B_NC2				
21	A_NO21			NO contact 1 relay output 2	
22	B_NO21				
23	A_NO22			NO contact 2 relay output 2	
24	B_NO22				

### XPSMCMER0008(G) Module Connector Designations

Terminal	Signal	LED	Type	Description	Operation
1	24 VDC	-	-	24 Vdc power supply	-
4	0 VDC			0 Vdc power supply	
5	OSSD1_A			Input	
6	OSSD1_B				
7	FBK_K1_K2_1_1	-	Output	Feedback relay output 1	-
8	FBK_K1_K2_1_2				
9	A_NC1	RELAY 1	Output	NC contact relay output 1	-
10	B_NC1				
13	A_NO11			NO contact 1 relay output 1	
14	B_NO11				
15	A_NO12			NO contact 2 relay output 1	
16	B_NO12				
17	OSSD2_A	-	Input	Control relay input 2	Input type 3. Maximum applicable resistance 1.2 kΩ.
18	OSSD2_B				
19	FBK_K1_K2_2_1	-	Output	Feedback relay output 2	-
20	FBK_K1_K2_2_2				
11	A_NC2	RELAY 2	Output	NC contact relay output 2	-
12	B_NC2				
21	A_NO21			NO contact 1 relay output 2	
22	B_NO21				
23	A_NO22			NO contact 2 relay output 2	
24	B_NO22				
25	24 VDC	-	-	24 VDC power supply	-
28	GND			0 VDC power supply	

Terminal	Signal	LED	Type	Description	Operation	
29	OSSD3_A	-	Input	Control relay output 3	Input type 3. Maximum applicable resistance 1.2 kΩ.	
30	OSSD3_B					
31	FBK_K1_K2_3_1	-	Output	Feedback relay output 3	-	
32	FBK_K1_K2_3_2					
33	A_NC3	RELAY 3	Output	NC contact relay output 3		
34	B_NC3					
37	A_NO31					NO contact 1 relay output 3
38	B_NO31					
39	A_NO32					NO contact 2 relay output 3
40	B_NO32					
41	OSSD4_A	-	Input	Control relay output 4	Input type 3. Maximum applicable resistance 1.2 kΩ.	
42	OSSD4_B					
43	FBK_K1_K2_4_1	-	Output	Feedback relay output 4	-	
44	FBK_K1_K2_4_2					
35	A_NC4	RELAY 4	Output	NC contact relay output 4		
36	B_NC4					
45	A_NO41					NO contact 1 relay output 4
46	B_NO41					
47	A_NO42					NO contact 2 relay output 4
48	B_NO42					

### XPSMCMER002(G) Module Sample Wiring Diagram

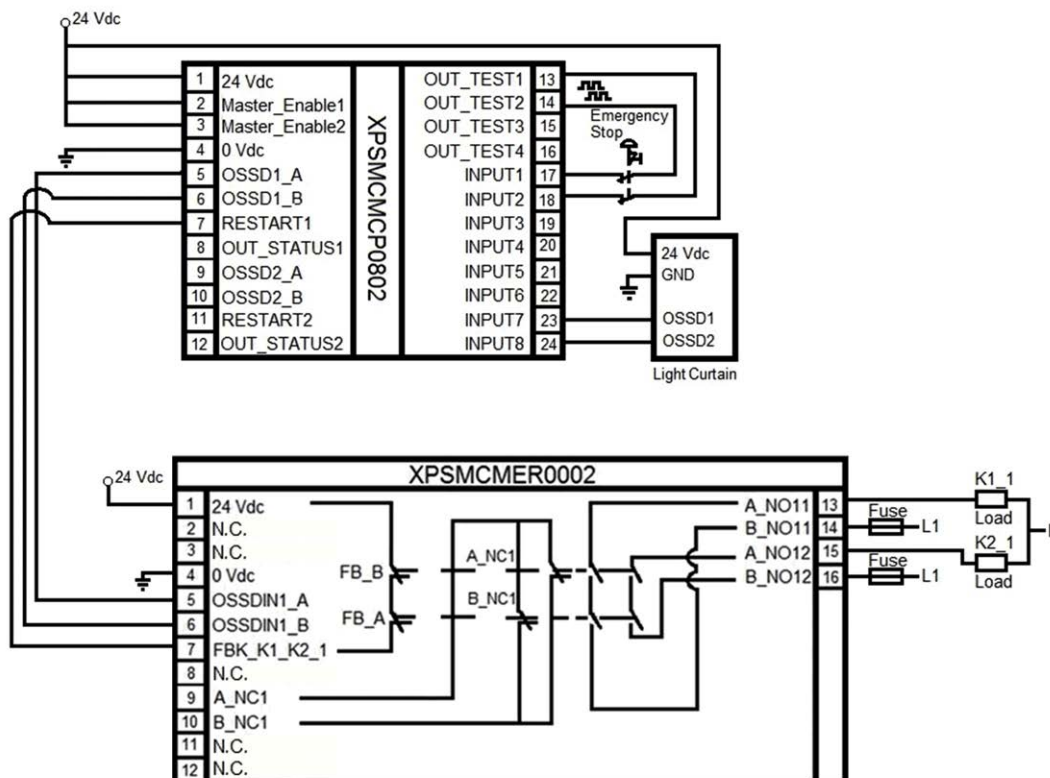

**⚠ WARNING**

**UNINTENDED EQUIPMENT OPERATION**

Do not connect wires to unused terminals and/or terminals indicated as "No Connection (N.C.)" or Not Connected.

**Failure to follow these instructions can result in death, serious injury, or equipment damage.**

### XPSMCMER0004(G) Module Sample Wiring Diagram

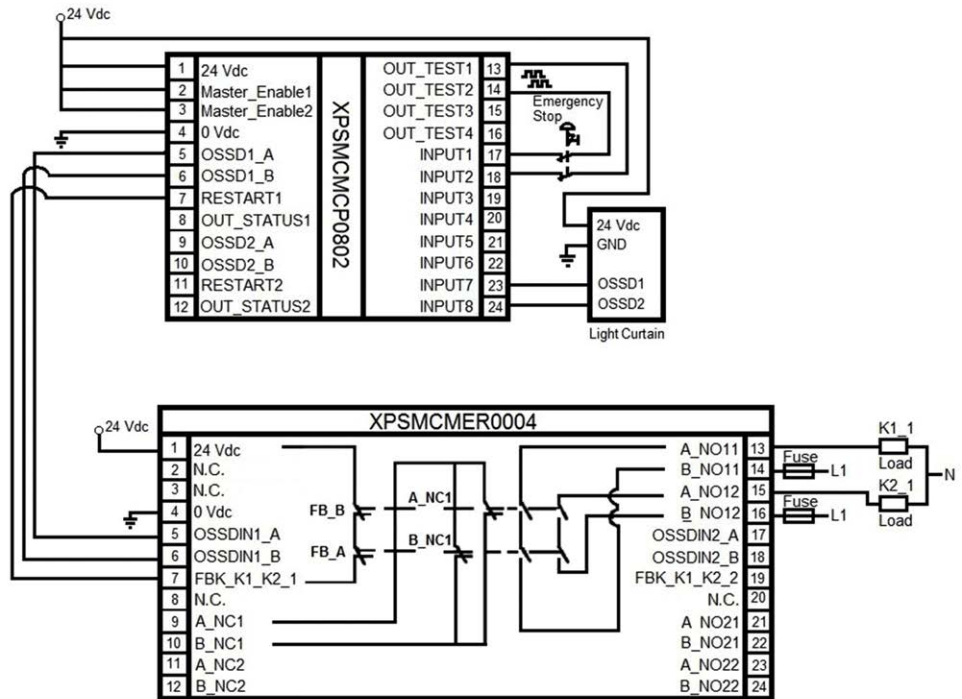

**NOTE:** Best practice dictates the use of fusing on the incoming 24 Vdc power, and sized appropriately for the requirements of the module.

**⚠ WARNING**

**UNINTENDED EQUIPMENT OPERATION**

Do not connect wires to unused terminals and/or terminals indicated as "No Connection (N.C.)" or Not Connected.

**Failure to follow these instructions can result in death, serious injury, or equipment damage.**

## XPSMCMER008(G) Module Sample Wiring Diagram

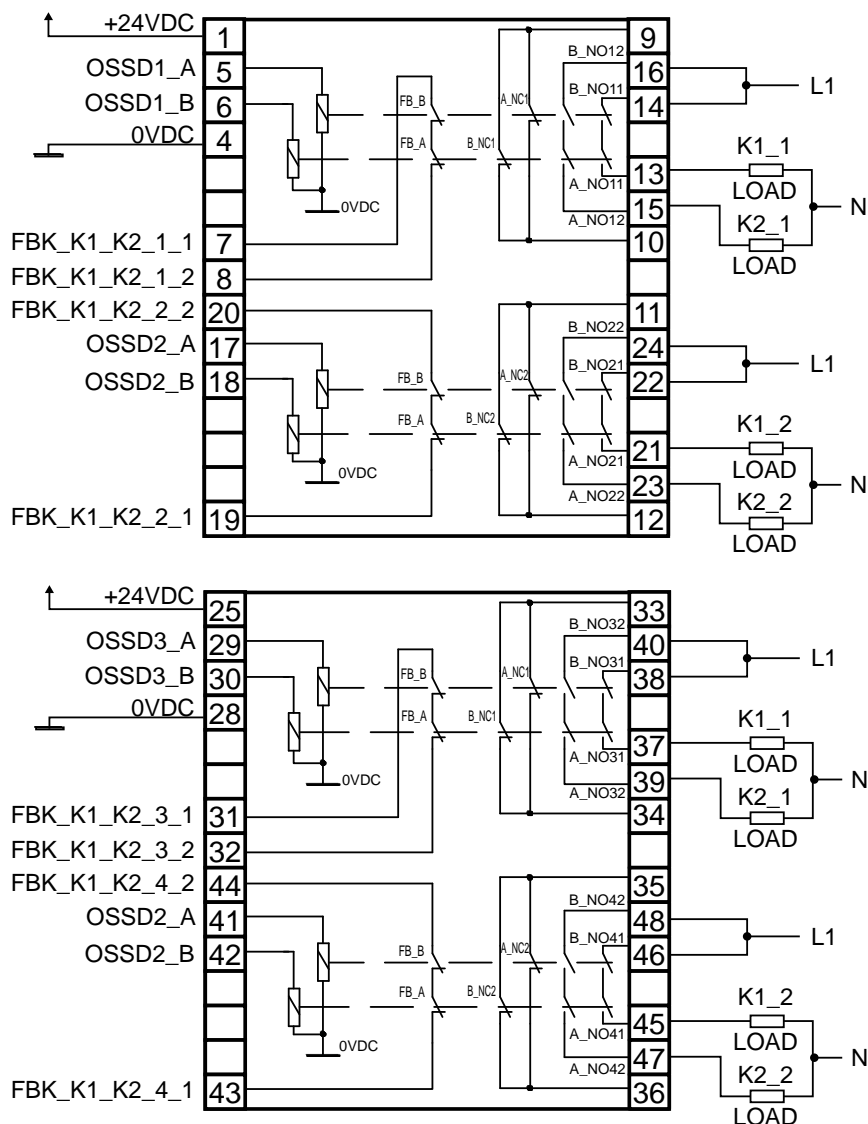

## Dimensions

Refer to Dimensions of the XPSMCMER008(G) Module, page 27.

## LED Indicators

### Front-Face View



### Operation State

The following table describes the operation state of the XPSMCMER00••(G) LED indicator(s):

RELAY green	Meaning
ON with output activated	Normal operation

## Module Characteristics

### Presentation

Module-specific characteristics	XPSMCMER0002(G)	XPSMCMER0004(G)	XPSMCMER0008(G)
Reference description	Electronic housing maximum 16 poles, with locking latch mounting	Electronic housing maximum 24 poles, with locking latch mounting	Electronic housing maximum 48 poles, with locking latch mounting
Switching capacity according to EN 60947-5-1	AC-15, 240 V, 3 A or DC-13, 24 V, 2 A		
Switching current (resistive)	6 A maximum (minimum 17 V at 10 mA)		
Relay contact type	2 NO + 1 NC	2 x (2 NO + 1 NC)	4 x (2 NO + 1 NC)
FEEDBACK contacts	1	2	4
Response time	12 ms		
Mechanical life of contacts	> 20 x 10 <sup>6</sup>		
Connection to expansion modules	No backplane expansion available, connection to digital outputs by hardwiring		
Weight	0.25 kg (8.8 oz)	0.3 kg (10.6 oz)	0,375 kg (13.2 oz)

**NOTE:** For the characteristics common to all modules, refer to General Characteristics, page 24.

**⚠ DANGER**

**FIRE HAZARD**

- Use only the correct wire sizes for the maximum current capacity of the I/O channels and power supplies.
- For relay output (2 A) wiring, use conductors of at least 0.5 mm<sup>2</sup> (AWG 20) with a temperature rating of at least 80 °C (176 °F).
- For common conductors of relay output wiring (7 A), or relay output wiring greater than 2 A, use conductors of at least 1.0 mm<sup>2</sup> (AWG 16) with a temperature rating of at least 80 °C (176 °F).

**Failure to follow these instructions will result in death or serious injury.**

**⚠ WARNING**

**UNINTENDED EQUIPMENT OPERATION**

Do not exceed any of the rated values specified in the characteristics tables.

**Failure to follow these instructions can result in death, serious injury, or equipment damage.**

**NOTE:** To help ensure correct isolation and avoid the risk of premature aging of, or damage to, the relays, each output line must be protected using an appropriately dimensioned, slow blow fuse that takes into account the maximum current of the relay, the load on the relay and the wire size between relay and load. The load characteristics must be consistent with those specified. For more important information on the protection of relay outputs, refer to Protecting Outputs from Inductive Load Damage, page 32.

**NOTE:** If a relay module is connected, the response time of the OSSD linked must be increased by 12 ms.

## Module Characteristics Concerning Safety

Module-specific characteristics concerning safety (XPSMCMER00**(G))									
-		Feedback contact used				Feedback contact not used			
-		PFHd	SFF (%)	MTTFd (years)	DCavg	PFHd	SFF (%)	MTTFd (years)	DCavg
DC-13 (2A)	t <sub>cycle1</sub>	3.09E-10	99.6	2335	98.9	9.46E-10	60	2335	0
	t <sub>cycle2</sub>	8.53E-11	99.7	24453	97.7	1.08E-10	87	24453	0
	t <sub>cycle3</sub>	6.63E-11	99.8	126678	92.5	6.75E-11	97	126678	0
AC-15 (3A)	t <sub>cycle1</sub>	8.23E-09	99.5	70	99.0	4.60E-07	50	70	0
	t <sub>cycle2</sub>	7.42E-10	99.5	848	99.0	4.49E-09	54	848	0
	t <sub>cycle3</sub>	1.07E-10	99.7	12653	98.4	1.61E-10	79	12653	0
AC-15 (1A)	t <sub>cycle1</sub>	3.32E-09	99.5	177	99.0	7.75E-08	51	177	0
	t <sub>cycle2</sub>	3.36E-10	99.6	2105	98.9	1.09E-09	60	2105	0
	t <sub>cycle3</sub>	8.19E-11	99.7	28549	97.5	1.00E-10	88	28549	0
t <sub>cycle1</sub> 300 s (1 commutation every 5 minutes) t <sub>cycle2</sub> 3600s (1 commutation every hour) t <sub>cycle3</sub> 1 commutation every day PFHd Probability of a dangerous failure per hour according IEC 61508 MTTFd and DCavg Mean Time to dangerous Failure and Diagnostic Coverage average according EN ISO 13849-1									

## Electrical Life of the Output Contacts

The graphic shows the electrical life of the output contacts determined by EN 60947-51-1:

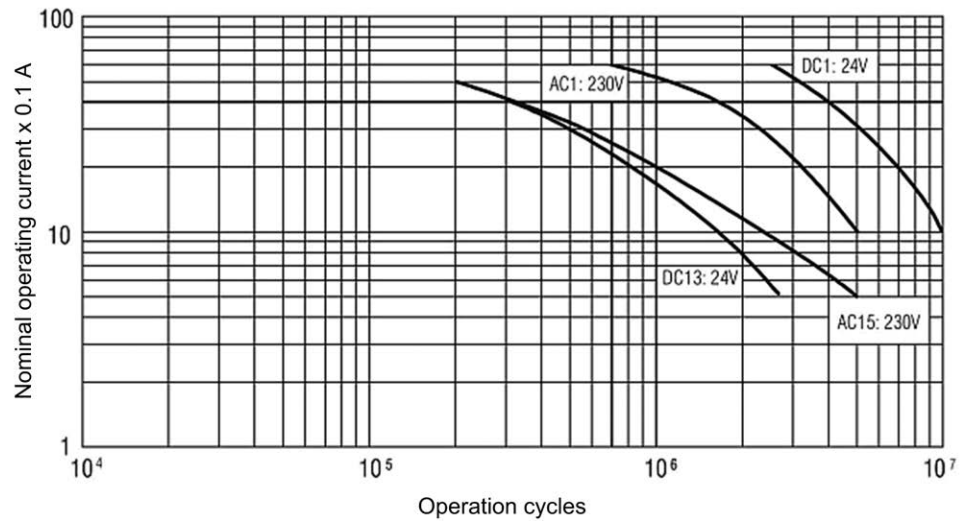

## Switching Operation Timing Diagram



## XPSMCMRO0004DA(G) and XPSMCMRO0004(G) Output Expansion Modules

### Module and Functional Description

#### Presentation

The XPSMCMRO0004(G) and XPSMCMRO0004DA(G) are output expansion modules for the XPSMCM• Modular Safety Controller. The XPSMCMRO0004(G) and XPSMCMRO0004DA(G) modules are configured with the XPSMCM• Modular Safety Controller. The XPSMCMRO0004(G) module provides two Category 4, or four Category 1, or two single-channel relay outputs. The XPSMCMRO0004DA(G) module provides two Category 4, or four Category 1, or two single-channel safety-related relay outputs. XPSMCMRO0004DA(G) provides eight additional status outputs. The diagnostic status outputs are configured using SoSafe Configurable.

The expansion module supports two inputs `NODE_ADDR0` and `NODE_ADDR1` which are used to set a physical address to the module:

	NODE_ADDR0 (Terminal 2)	NODE_ADDR1 (Terminal 3)
NODE 0	0 (or not connected)	0 (or not connected)
NODE 1	24 Vdc	0 (or not connected)
NODE 2	0 (or not connected)	24 Vdc
NODE 3	24 Vdc	24 Vdc
<p><b>NOTE:</b> Do not use the same physical address for two units of the same module reference.</p> <p><b>NOTE:</b> The LEDs <b>ADDR 1</b> and <b>ADDR 0</b> correspond to the NODE_ADDR1 and NODE_ADDR0 in this table respectively.</p> <p><b>NOTE:</b> The node address wiring must match the configuration settings.</p>		

## Input RESTART (RST)

For more information, refer to Input RESTART (RST), page 37.

## Output STATUS for XPSMCMRO0004DA(G) (SIL 1/PL c in Accordance with Standard EN 61508:2010)

The status outputs are configurable digital diagnostic outputs that indicate the status of safety-related inputs and/or outputs.

For more information, refer to Output STATUS, page 107.

## Connector Designations and Sample Wiring Diagrams

### XPSMCMRO0004DA(G) Module Connector Designations

The connections for the XPSMCMRO0004(G) module are identical without the status outputs occupying terminals 17 through 24.

Terminal	Signal	LED	Type	Description	Operation
1	24 VDC	PWR	–	24 Vdc power supply	–
2	NODE_ADDR0	ADDR0	Input	Node selection	Input type 3 according to EN 61131-2. Maximum resistance 1.2 kΩ.
3	NODE_ADDR1	ADDR1			
4	0 VDC	PWR	–	0 Vdc power supply	–
5	RESTART1	RST 1	Input	Feedback/Restart 1	Input type 3 according to EN 61131-2. Maximum resistance 1.2 kΩ.
6	RESTART2	RST 2		Feedback/Restart 2	
7	RESTART3	RST 3		Feedback/Restart 3	
8	RESTART4	RST 4		Feedback/Restart 4	
9	A_NO1	RELAY 1	Out-put	NO contact channel 1	–
10	B_NO1				
11	A_NO2	RELAY 2		NO contact channel 2	
12	B_NO2				
13	A_NO3	RELAY 3		NO contact channel 3	
14	B_NO3				
15	A_NO4	RELAY 4		NO contact channel 4	
16	B_NO4				

Terminal	Signal	LED	Type	Description	Operation
17	OUT_STATUS 1	STATUS 1	Output	Configurable diagnostic output	PNP active at Uv (24 Vdc ± 20%).
18	OUT_STATUS 2	STATUS 2			
19	OUT_STATUS 3	STATUS 3			
20	OUT_STATUS 4	STATUS 4			
21	OUT_STATUS 5	STATUS 5			
22	OUT_STATUS 6	STATUS 6			
23	OUT_STATUS 7	STATUS 7			
24	OUT_STATUS 8	STATUS 8			

### XPSMCMRO0004DA(G) Module Sample Wiring Diagrams

The connections for the XPSMCMRO0004(G) module are identical without the status outputs occupying terminals 17 through 24.

#### Category 2 wiring

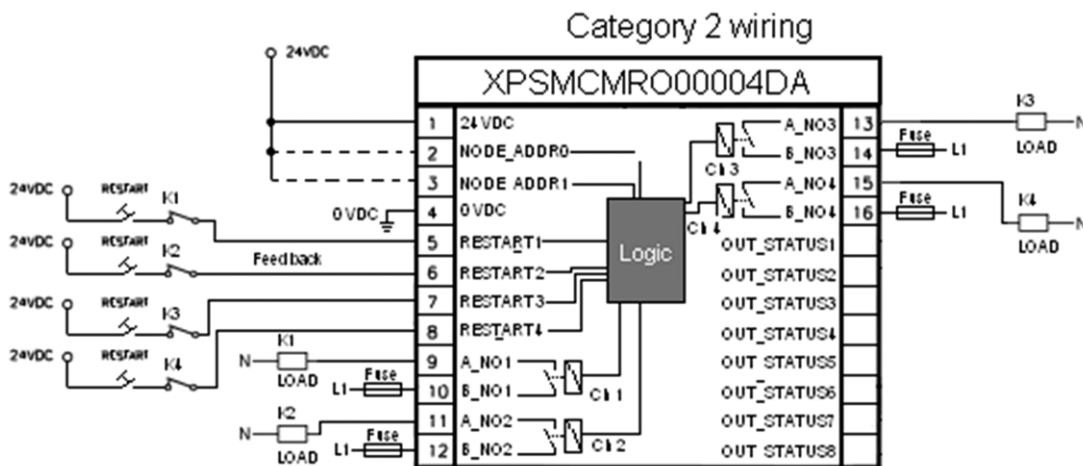

**NOTE:** Best practice dictates the use of fusing on the incoming 24 Vdc power, and sized appropriately for the requirements of the module.

Category 4 wiring

Category 4 wiring

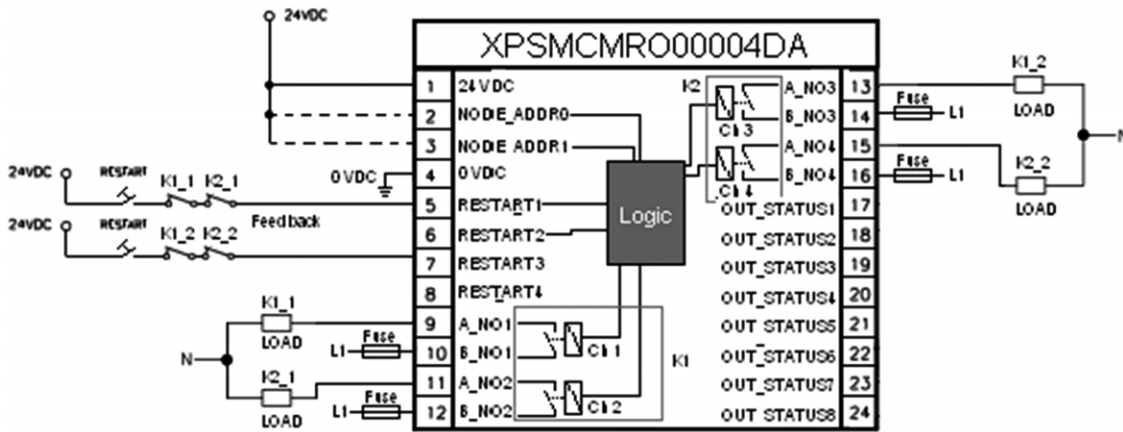

**NOTE:** Best practice dictates the use of fusing on the incoming 24 Vdc power, and sized appropriately for the requirements of the module.

## LED Indicators

### Front-Face View

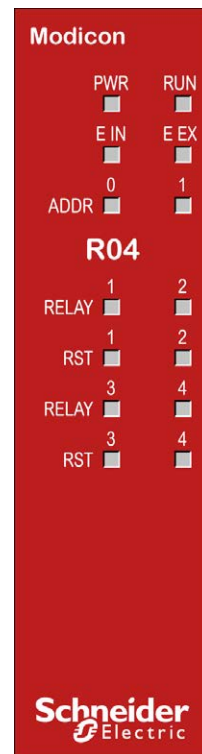

## Operation States

The following table describes the indication of operation states of the XPSMCMRO0004DA(G) by means of the LEDs. The LED descriptions for the XPSMCMRO0004(G) are identical except that it does not have the **STATUS** LEDs. The description assumes that the power LED (**PWR**) is ON:

RUN green	E IN red	E EX red	ADDR 0...1 orange	RELAY 1...4 red/green	RST 1...4 yellow	STATUS 1...8 yellow	Meaning
ON	ON	ON	ON	Red	ON	ON	Power on - initial test
OFF = awaiting initialization	OFF	OFF	Encoded Node address, page 124	Output state: red = 0 (contact opened)  green = 1 (contact closed)	ON = waiting for restart	Output diagnostics	Normal operation
Flashing = no inputs or outputs configured					Flashing = no feedback		
ON = inputs or outputs configured							

## Troubleshooting

The following table describes the indication of detected errors of the XPSMCMRO0004DA(G) and XPSMCMRO0004(G) by means of the LEDs. The description assumes that the power LED (**PWR**) is ON:

Detected error	RUN green	E IN red	E EX red	ADDR 0...1 orange	RELAY 1...4 red/green	RST 1...4 yellow	Solution
Internal error detected.	OFF	2 or 3 flashes	OFF	Encoded Node address, page 124	Red	OFF	Product non serviceable <sup>(1)</sup> .
Compatibility error detected.	OFF	5 flashes	OFF		5 flashes		Firmware version not compatible with the controller.
Relay output error detected.	OFF	4 flashes	OFF		4 flashes <sup>1</sup>	OFF	Product non serviceable <sup>(1)</sup> .
Error detected in the communication with controller.	OFF	5 flashes	OFF		OFF	OFF	Reboot the system.
Error detected on other expansion module or controller.	OFF	ON	OFF		OFF	OFF	Reboot the system <sup>(1)</sup> .  Verify which module /controller is in error and consult its troubleshooting guide.
Two units of the same module reference detected with the same node address.	OFF	5 flashes			OFF	OFF	Modify the unit node address, page 124.
No external feedback category 4 relay.	ON	OFF	4 flashes		4 red flashes	OFF	Verify connection 5,6,7,8.
Error detected on node detection circuit.	OFF	3 flashes	OFF	3 flashes	OFF	OFF	Product non serviceable <sup>(1)</sup> .
<b>(1)</b> If the condition persists, contact your local Schneider Electric representative.							

## Module Characteristics

### Presentation

Module-specific characteristics	XPSMCMRO0004(G)	XPSMCMRO0004DA(G)
Reference description	Electronic housing maximum 16 poles, with locking latch mounting	Electronic housing maximum 24 poles, with locking latch mounting
Nominal switching capacity according to EN 60947-5-1	AC-15, 230 V, 3 A or DC-13, 24 V, 2 A  AC-1, 230 V, 6 A  DC-1, 24 V, 6 A	

Module-specific characteristics	XPSMCMRO0004(G)	XPSMCMRO0004DA(G)
Commutation voltage	17...31 Vdc	
Minimum switching voltage	10 Vdc	
Minimum switching current	20 mA	
Maximum switching voltage (DC)	250 Vdc	
Maximum switching voltage (AC)	400 Vac	
Relay contact type	4	
FEEDBACK contacts	4 / EDM (External Device Monitoring) input type 3 according to EN 61131-2. Maximum applicable resistance 1.2 kΩ. / Possible automatic restart function or manual operation with restart pushbutton	
Status outputs	-	8 configurable diagnostic outputs PNP active high 100 mA, nominal voltage 24 Vdc
Response time	12 ms	
Mechanical life of contacts	> 20 x 10 <sup>6</sup>	
Connection to expansion modules	5-way backplane expansion	
Weight	0.12 kg (4.2 oz)	

**NOTE:** For the characteristics common to all modules, refer to General Characteristics, page 24.

**⚠ DANGER**

**FIRE HAZARD**

- Use only the correct wire sizes for the maximum current capacity of the I/O channels and power supplies.
- For relay output (2 A) wiring, use conductors of at least 0.5 mm<sup>2</sup> (AWG 20) with a temperature rating of at least 80 °C (176 °F).
- For common conductors of relay output wiring (7 A), or relay output wiring greater than 2 A, use conductors of at least 1.0 mm<sup>2</sup> (AWG 16) with a temperature rating of at least 80 °C (176 °F).

**Failure to follow these instructions will result in death or serious injury.**

**⚠ WARNING**

**UNINTENDED EQUIPMENT OPERATION**

Do not exceed any of the rated values specified in the characteristics tables.

**Failure to follow these instructions can result in death, serious injury, or equipment damage.**

**NOTE:** To help ensure correct isolation and avoid the risk of premature aging of, or damage to, the relays, each output line must be protected using an appropriately dimensioned, slow blow fuse that takes into account the maximum current of the relay, the load on the relay and the wire size between relay and load. The load characteristics must be consistent with those specified. For more important information on the protection of relay outputs, refer to Protecting Outputs from Inductive Load Damage, page 32.

**NOTE:** If a relay module is connected, the response time of the OSSD linked must be increased by 12 ms.

## Module Characteristics Concerning Safety

Module-specific characteristics concerning safety (XPSMCMRO0004(G)/XPSMCMRO0004DA(G))									
-		Feedback contact used				Feedback contact not used			
		PFHd	SFF (%)	MTTFd (years)	DCavg	PFHd	SFF (%)	MTTFd (years)	DCavg
DC-13 (2A)	t <sub>cycle1</sub>	3.09E-10	99.6	2335.94	98.9	9.46E-10	60	2335.93	0
	t <sub>cycle2</sub>	8.53E-11	99.7	24453.47	97.7	1.08E-10	87	24453.47	0
	t <sub>cycle3</sub>	6.63E-11	99.8	126678.49	92.5	6.75E-11	97	126678.5	0
AC-15 (3A)	t <sub>cycle1</sub>	8.23E-09	99.5	70.99	99.0	4.60E-07	50	70.99	0
	t <sub>cycle2</sub>	7.42E-10	99.5	848.16	99.0	4.49E-09	54	848.15	0
	t <sub>cycle3</sub>	1.07E-10	99.7	12653.85	98.4	1.61E-10	79	12653.85	0
AC-15 (1A)	t <sub>cycle1</sub>	3.32E-09	99.5	177.38	99.0	7.75E-08	51	177.37	0
	t <sub>cycle2</sub>	3.36E-10	99.6	2105.14	98.9	1.09E-09	60	2105.14	0
	t <sub>cycle3</sub>	8.19E-11	99.7	28549.13	97.5	1.00E-10	88	28549.13	0

t<sub>cycle1</sub> 300 s (1 commutation every 5 minutes)  
t<sub>cycle2</sub> 3600s (1 commutation every hour)  
t<sub>cycle3</sub> 1 commutation every day  
**PFHd** Probability of a dangerous failure per hour according IEC 61508  
**MTTFd and DCavg** Mean Time to dangerous Failure and Diagnostic Coverage average according EN ISO 13849-1

## Electrical Life of the Output Contacts

The graphic shows the electrical life of the output contacts determined by EN 60947-51-1:

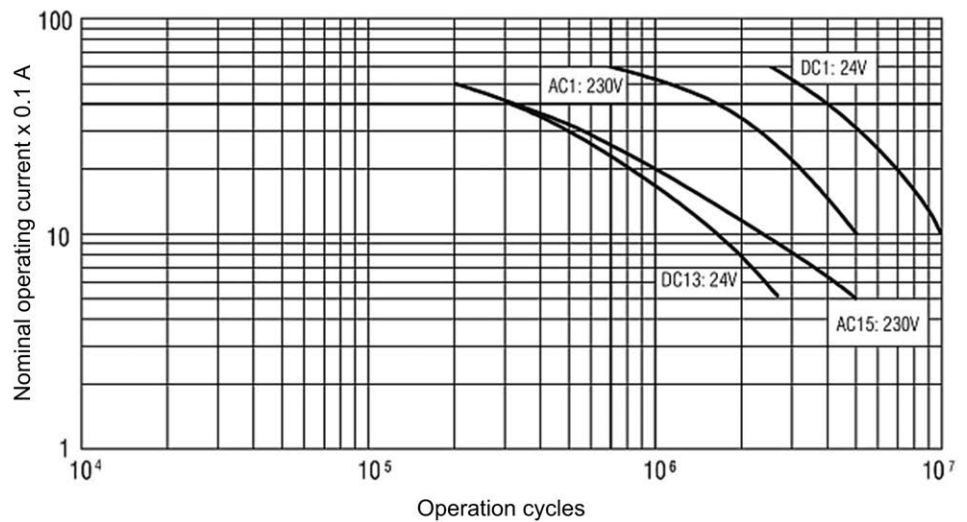

# XPSMCMMX0802(G) Input/Output Expansion Module

## Module and Functional Description

### Presentation

The XPSMCMMX0802(G) is an input/output expansion module and is configured with the XPSMCM• Modular Safety Controller. The XPSMCMMX0802(G) module provides eight safety-related inputs and two dual safety-related outputs.

The expansion module supports two inputs `NODE_ADDR0` and `NODE_ADDR1` which are used to set a physical address to the module:

	<b>NODE_ADDR0 (Terminal 2)</b>	<b>NODE_ADDR1 (Terminal 3)</b>
NODE 0	0 (or not connected)	0 (or not connected)
NODE 1	24 Vdc	0 (or not connected)
NODE 2	0 (or not connected)	24 Vdc
NODE 3	24 Vdc	24 Vdc

**NOTE:** Do not use the same physical address for two units of the same module reference.

**NOTE:** The LEDs **ADDR 1** and **ADDR 0** correspond to the `NODE_ADDR1` and `NODE_ADDR0` in this table respectively.

**NOTE:** The node address wiring must match the configuration settings.

### Input RESTART (RST)

For more information, refer to Input RESTART (RST), page 37.

### Output STATUS (SIL 1/PL c in Accordance with Standard EN 61508:2010)

The status outputs are configurable digital diagnostic outputs that indicate the status of safety-related inputs and/or outputs.

For more information, refer to Output STATUS, page 107.

### Output TEST

For more information, refer to Output TEST, page 37.

### Solid-State Safety-Related Output (OSSD)

For more information, refer to Solid-State safety-related output (OSSD), page 38.

## Connector Designations and Sample Wiring Diagrams

### XPSMCMMX0802(G) Module Connector Designations

Terminal	Signal	LED	Type	Description	Operation
1	24 VDC	PWR	-	24 Vdc power supply	-
2	NODE_ADDR0	ADDR0	Input	Node selection	Input type 3 according to EN 61131-2. Maximum resistance 1.2 kΩ.
3	NODE_ADDR1	ADDR1			
4	0 VDC	PWR	-	0 Vdc power supply	-
5	OSSD1_A	OSSD 1	Output	Safety-related output 1	PNP active at Uv (24 Vdc ± 20%).
6	OSSD1_B				
7	RESTART1	RST 1	Input	Feedback/Restart 1	Input type 3 according to EN 61131-2. Maximum resistance 1.2 kΩ.
8	OUT_STATUS 1	STATUS 1	Output	Configurable diagnostic output	Configurable output (SIL 1/ PL c in accordance with EN 61508:2010)
9	OSSD2_A	OSSD 2		Safety-related output 2	PNP active at Uv (24 Vdc ± 20%).
10	OSSD2_B	OUT 2			
11	RESTART2	RST 2	Input	Feedback/restart 2	Input type 3 according to EN 61131-2. Maximum resistance 1.2 kΩ.
12	OUT_STATUS 2	STATUS 2	Output	Configurable diagnostic output	Configurable output (SIL 1/ PL c in accordance with EN 61508:2010)
13	OUT_TEST1	-		Test output for detection of short circuits/cross circuits in input circuits	PNP active at 24 Vdc.
14	OUT_TEST2	-			
15	OUT_TEST3	-			
16	OUT_TEST4	-			
17	INPUT1	IN 1	Input	Safety-related input 1	Input type 3 according to EN 61131-2. Maximum resistance 1.2 kΩ.
18	INPUT2	IN 2		Safety-related input 2	
19	INPUT3	IN 3		Safety-related input 3	
20	INPUT4	IN 4		Safety-related input 4	
21	INPUT5	IN 5		Safety-related input 5	
22	INPUT6	IN 6		Safety-related input 6	
23	INPUT7	IN 7		Safety-related input 7	
24	INPUT8	IN 8		Safety-related input 8	

### XPSMCMMX0802(G) Module Sample Wiring Diagrams

Category 3 wiring for XPSMCMMX0802(G):

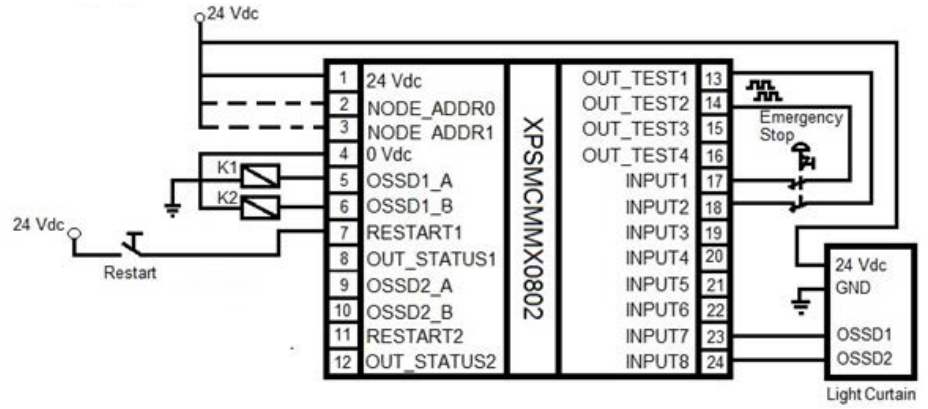

**NOTE:** Best practice dictates the use of fusing on the incoming 24 Vdc power, and sized appropriately for the requirements of the module.

Category 4 wiring for XPSMCMX0802(G) with feedback of the contactors K1 and K2:

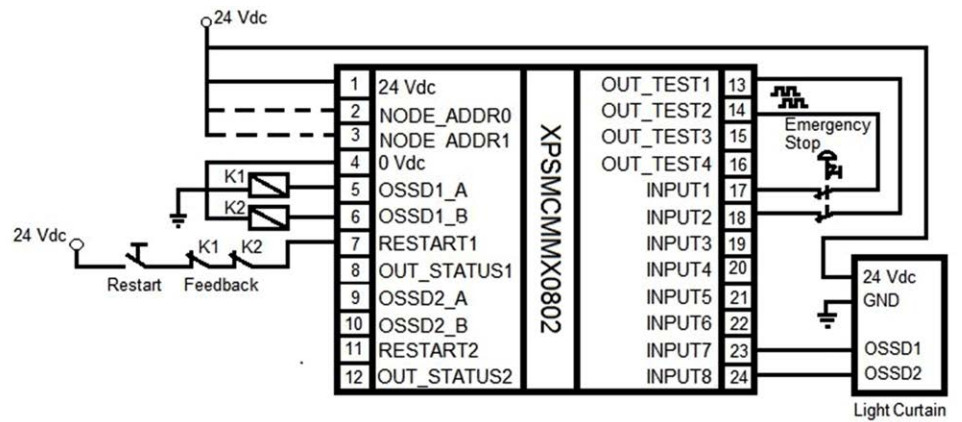

**NOTE:** Best practice dictates the use of fusing on the incoming 24 Vdc power, and sized appropriately for the requirements of the module.

## LED Indicators

### Front-Face View

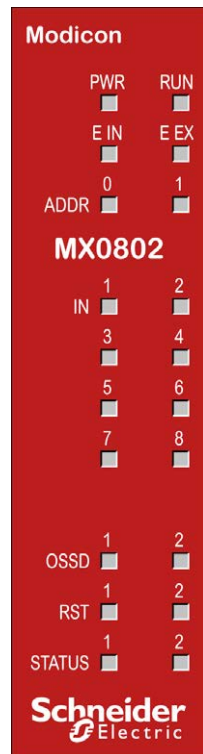

## Operation States

The following table describes the indication of operation states of the XPSMCMX0802(G) by means of the LEDs. The description assumes that the power LED (**PWR**) is ON:

RUN green	E IN red	E EX red	ADDR 0...1 orange	IN 1...8 yellow	OSSD 1...2 red/ green	RST 1...2 yellow	STATUS 1...2 yellow	Meaning
ON	ON	ON	ON	ON	red	ON	ON	Power on - initial test
OFF = awaiting initialization	OFF	OFF	Encoded Node address, page 131	Input state	Red = output OFF	ON = waiting for restart	Output diagnostics	Normal operation
Flashing = no inputs or outputs configured		ON = Wiring error detected		Flashing = input with error	Green = output ON	Flashing = no feedback		
ON = inputs or outputs configured								

## Troubleshooting

The following table describes the indication of detected errors of the XPSMCMX0802(G) by means of the LEDs. The description assumes that the power LED (**PWR**) is ON:

Detected error	RUN green	E IN red	E EX red	IN 1...8 yellow	OSSD 1...2 red/ green	RST 1...2 yellow	STATUS 1...2 yellow	Solution
Internal error detected.	OFF	2 or 3 flashes	OFF	OFF	red	OFF	OFF	Product non serviceable <sup>(1)</sup> .
Compatibility error detected.	OFF	5 flashes	OFF	5 flash- es	red 5 flashes	5 flashes	5 flashes	Firmware version not compatible with the controller <sup>(1)</sup> .
OSSD output error detected.	OFF	4 flashes	OFF	OFF	red 4 flashes	OFF	OFF	Verify solid state safety-related output (OSSD)1/2 connections.
Error detected in the communication with controller.	OFF	5 flashes	OFF	OFF				Reboot the system <sup>(1)</sup> .
Error detected on other expansion module or controller.	OFF	ON	OFF	OFF				Reboot the system.  Verify which module/controller is in error and consult its troubleshooting guide.
Two units of the same module reference detected with the same node address.	OFF	5 flashes	5 flash- es	OFF				Modify the unit node address, page 131 <i>NODE ADDR</i> .

(1) If the condition persists, contact your local Schneider Electric representative.

## Module Characteristics

### Presentation

Module-specific characteristics	
Reference description	Electronic housing maximum 24-poles, with locking latch mounting
Unit enable (No./description)	2 / Input type 3 according to EN 61131-2. Maximum applicable resistance 1.2 kΩ.
Digital inputs (No./description)	8 / Input type 3 according to EN 61131-2. Maximum applicable resistance 1.2 kΩ.
Restart input (No./description)	2 / EDM (External Device Monitoring) input type 3 according to EN 61131-2. Maximum applicable resistance 1.2 kΩ. / Possible automatic restart function or manual operation with restart pushbutton
Test output (No./description)	4 / to test for cross circuits - short circuits, maximum current 100 mA, nominal voltage 24 Vdc
Solid-state safety-related output (OSSD) (No./description)	2 pairs / solid-state safety-related outputs PNP active high <ul style="list-style-type: none"> <li>• The outputs are able to supply:                             <ul style="list-style-type: none"> <li>◦ In the ON condition: <math>U_v - 0.75 V \dots U_v</math> where <math>U_v = 24 V_{dc} \pm 20\%</math></li> <li>◦ In the OFF condition: 0 to 2 Vrms (root mean square)</li> </ul> </li> <li>• The maximum load current of 400 mA (per OSSD) corresponds to a minimum resistive load of 60 Ω.</li> <li>◦ The maximum capacitive load is 0.68 μF.</li> <li>◦ The maximum inductive load is 2 mH.</li> <li>• To detect short circuit and line break on the outputs, a line monitoring is made by using an output pulse on each channel. The output pulse is generated every 20 ms with a pulse of &lt; 120 μs..</li> </ul>
Status outputs	Maximum output current per channel: 100 mA, nominal voltage 24 Vdc
Probability of a dangerous failure per hour (PFHd)	5.67E-9

Module-specific characteristics	
Mean Time to Dangerous Failure (MTTFd) in years	459
Connection to expansion modules	5-way backplane expansion
Weight	0.12 kg (4.2 oz)

**NOTE:** For the characteristics common to all modules, refer to General Characteristics, page 24.

**⚠ DANGER**

**FIRE HAZARD**

Use only the correct wire sizes for the maximum current capacity of the I/O channels and power supplies.

**Failure to follow these instructions will result in death or serious injury.**

**⚠ WARNING**

**UNINTENDED EQUIPMENT OPERATION**

Do not exceed any of the rated values specified in the characteristics tables.

**Failure to follow these instructions can result in death, serious injury, or equipment damage.**

## XPSMCMMX0804(G) Input/Output Expansion Module

### Module and Functional Description

#### Presentation

The XPSMCMMX0804(G) module is an input/output expansion module that can only be configured with the XPSMCMC10804(G) or XPSMCMC10804E(G) Modular Safety Controller. The XPSMCMMX0804(G) module provides eight safety-related inputs, four solid-state safety-related outputs which can be used as four single or two dual (Output Signal Switching Device, OSSD) and four SIL 1/PL c status outputs.

The expansion module supports two inputs `NODE_ADDR0` and `NODE_ADDR1` which are used to set a physical address to the module:

	<b>NODE_ADDR0 (Terminal 2)</b>	<b>NODE_ADDR1 (Terminal 3)</b>
NODE 0	0 (or not connected)	0 (or not connected)
NODE 1	24 Vdc	0 (or not connected)
NODE 2	0 (or not connected)	24 Vdc
NODE 3	24 Vdc	24 Vdc

- NOTE:** Do not use the same physical address for two units of the same module reference.
- NOTE:** The LEDs **ADDR 1** and **ADDR 0** correspond to the `NODE_ADDR1` and `NODE_ADDR0` in this table respectively.
- NOTE:** The node address wiring must match the configuration settings.

## Input RESTART (RST)

For more information, refer to the description of the Input RESTART of the XPSMCMC10804(G), page 44.

## Output STATUS (SIL 1/PL c in Accordance with Standard EN 61508:2010)

The status outputs are configurable digital diagnostic outputs that indicate the status of safety-related inputs and/or outputs.

For more information, refer to the description of the Output STATUS of the XPSMCMC10804(G), page 45.

## Output TEST

For more information, refer to the description of the Output TEST of the XPSMCMC10804(G), page 45.

## Solid-State Safety-Related Output (OSSD)

For more information, refer to the description of the Solid-State safety-related output (OSSD) of the XPSMCMC10804(G), page 46.

# Connector Designations and Sample Wiring Diagrams

## XPSMCMX0804(G) Module Connector Designations

Terminal	Signal	LED	Type	Description	Operation
1	24 VDC	PWR	-	24 Vdc power supply	-
2	NODE_ADDR0	ADDR0	Input	Node selection	Input type 3 according to EN 61131-2. Maximum resistance 1.2 kΩ.
3	NODE_ADDR1	ADDR1			
4	0 VDC	PWR	-	0 Vdc power supply	-
5	OSSD1	OSSD 1	Output	Safety-related output 1	PNP active at Uv (24 Vdc ± 20%).
6	OSSD2	OSSD 2	Output	Safety-related output 2	
7	RESTART_FBK1/ STATUS1	RST_FBK/ STATUS 1	Input / output	Feedback/Restart 1 for OSSD1	Input type 3 according to EN 61131-2. Maximum resistance 1.2 kΩ.
				Configurable output 1 for OSSD1	Configurable output (SIL 1/ PL c in accordance with EN 61508:2010)
8	RESTART_FBK2 / STATUS2	RST_FBKSTA- TUS 2	Input / output	Feedback/Restart 2 for OSSD2	Input type 3 according to EN 61131-2. Maximum resistance 1.2 kΩ.
				Configurable output 2 for OSSD2	Configurable output (SIL 1/ PL c in accordance with EN 61508:2010)
9	OSSD3	OSSD 3	Output	Safety-related output 3	PNP active at Uv (24 Vdc ± 20%).
10	OSSD4	OSSD 4	Output	Safety-related output 4	

Terminal	Signal	LED	Type	Description	Operation
11	RESTART_FBK3/ STATUS3	RST_FBKSTATUS 3	Input / output	Feedback/Restart 3 for OSSD3	Input type 3 according to EN 61131-2. Maximum resistance 1.2 kΩ.
				Configurable output 3 for OSSD3	Configurable output (SIL 1/ PL c in accordance with EN 61508:2010)
12	RESTART_FBK4/ STATUS4	RST_FBKSTATUS 4	Input / output	Feedback/Restart 4 for OSSD4	Input type 3 according to EN 61131-2. Maximum resistance 1.2 kΩ.
				Configurable output 4 for OSSD4	Configurable output (SIL 1/ PL c in accordance with EN 61508:2010)
13	OUT_TEST1	-	Output	Test output for detection of short circuits/cross circuits in input circuits	PNP active at 24 Vdc.
14	OUT_TEST2	-			
15	OUT_TEST3	-			
16	OUT_TEST4	-			
17	INPUT1	IN 1	Input	Safety-related input 1	Input type 3 according to EN 61131-2. Maximum resistance 1.2 kΩ.
18	INPUT2	IN 2		Safety-related input 2	
19	INPUT3	IN 3		Safety-related input 3	
20	INPUT4	IN 4		Safety-related input 4	
21	INPUT5	IN 5		Safety-related input 5	
22	INPUT6	IN 6		Safety-related input 6	
23	INPUT7	IN 7		Safety-related input 7	
24	INPUT8	IN 8		Safety-related input 8	

# XPSMCMX0804(G) Module Sample Wiring Diagrams

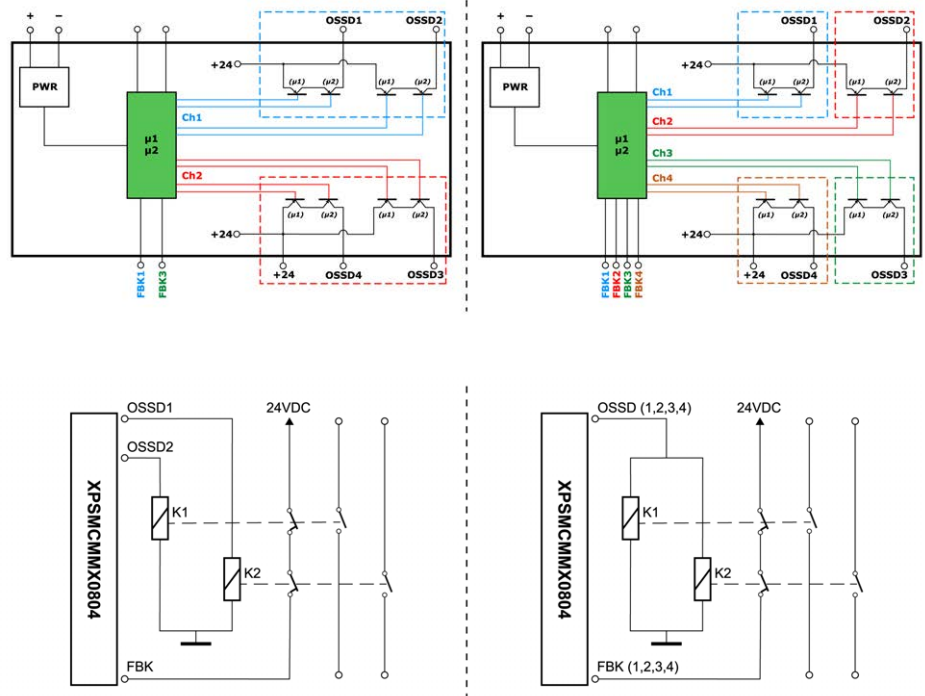

Dual channel OSSD configuration with 2 dual channel outputs, safety category SIL3/PL e: EN 61508:2010

Single channel OSSD configuration with 4 single outputs, safety category SIL3/PL e: EN 61508:2010

### Category 3 wiring for XPSMCMX0804(G):

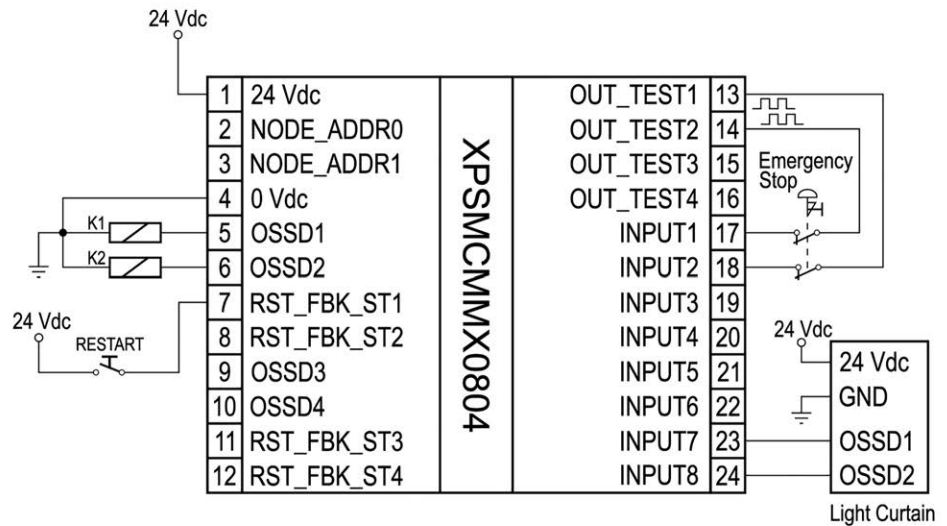

**NOTE:** Best practice dictates the use of fusing on the incoming 24 Vdc power, and sized appropriately for the requirements of the module.

Category 4 wiring for XPSMCMMX0804(G) with feedback of the contactors K1 and K2:

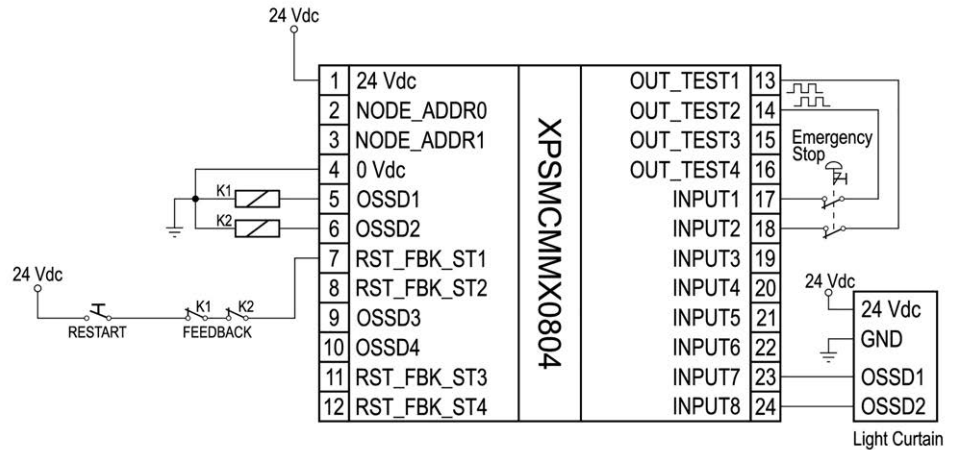

**NOTE:** Best practice dictates the use of fusing on the incoming 24 Vdc power, and sized appropriately for the requirements of the module.

Category 4 wiring for XPSMCMMX0804(G) with feedback of the contactors K1 and K2 and RESTART connected to module inputs:

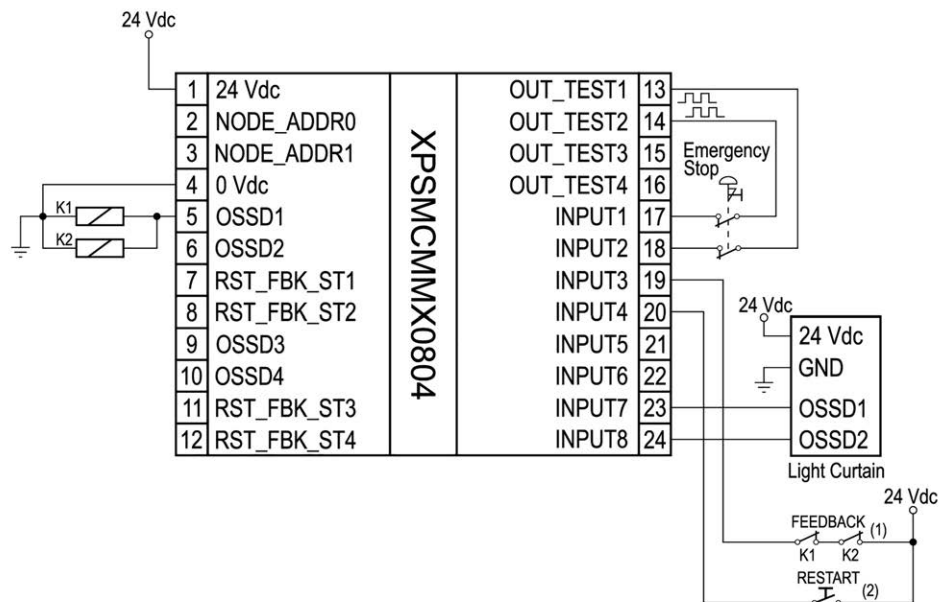

(1) Contacts connected to the OSSD EDM functional block

(2) Contacts connected to the *USER RESTART MANUAL*, *USER RESTART MONITORED* or *MACRO RESTART MANUAL*, *MACRO RESTART MONITORED* function block

**NOTE:** Best practice dictates the use of fusing on the incoming 24 Vdc power, and sized appropriately for the requirements of the module.

## LED Indicators

### Front-Face View

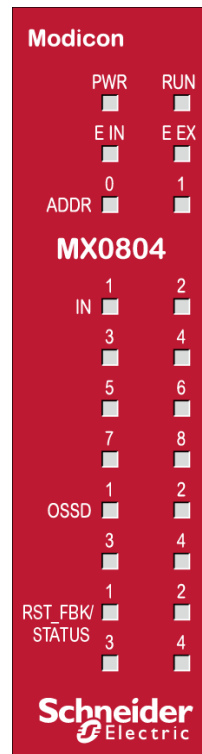

## Operation States

The following table describes the indication of operation states of the XPSMCMX0804(G) by means of the LEDs. The description assumes that the power LED (**PWR**) is ON:

<b>RUN</b> green	<b>E IN</b> red	<b>E EX</b> red	<b>ADDR 0...1</b> orange	<b>IN 1...8</b> yellow	<b>OSSD 1...4</b> red/ green/yellow	<b>RST_FBK/ STATUS 1...4</b> yellow	<b>Meaning</b>
ON	ON	ON	ON	ON	Red	ON	Power on - initial test
OFF = awaiting initialization	OFF	OFF	Encoded Node address, page 136	Reflect input state	Red = output OFF	Reflect status output state	Normal operation
Flashing = no inputs or outputs configured					Green = output ON		
ON = inputs or outputs configured					Steady yellow = waiting for restart Flashing yellow = no feedback		

## Troubleshooting

The following table describes the indication of detected errors of the XPSMCMX0804(G) by means of the LEDs. The description assumes that the power LED (**PWR**) is ON:

Detected error	RUN green	E IN red	E EX red	ADDR 0...1 or- ange	IN 1...8 yellow	OSSD 1...4 red/ green/ yellow	RST_ FBK/ STATUS 1...4 yellow	Solution
Internal error detected.	OFF	2 or 3 flashes periodi- cally repeated	OFF	Enco- ded Node ad- dress, page 136	OFF	Red	OFF	Product non serviceable <sup>(1)</sup> .
Compatibility error detected.	OFF	5 flashes	OFF		5 flash- es	Red 5 flashes	5 flashes	Firmware version not compatible with controller <sup>(1)</sup> .
OSSD output error detected.	OFF	4 flashes	OFF		OFF	Red 4 flashes (only corre- spond- ing LED)	OFF	Verify correct wiring of the safety-related outputs (OSSD) <sup>(1)</sup> .
Error in the communication with controller detected.	OFF	5 flashes	OFF		OFF	OFF	OFF	Restart the system <sup>(1)</sup> .
Expansion module or controller error detected.	OFF	ON	OFF		OFF	OFF	OFF	Restart the system.  Identify the expansion module affected by this condition and consult its user guide <sup>(1)</sup> .
Two units of the same module reference detected with the same node address.	OFF	5 flashes	5 flashes		OFF	OFF	OFF	Modify the unit node address, page 136.
Overload on OSSD / OSSD load connected to 24 Vdc detected.	ON	OFF	ON		Input state	Flashing red (only corre- spond- ing LED)	Reflect status output state	Verify correct wiring of the safety-related outputs (OSSD) <sup>(1)</sup> .
Short circuit or overload on status output detected.	ON	OFF	ON		ON	Output state	Flashing	Verify correct wiring of STATUS output <sup>(1)</sup> .
<b>(1)</b> If the condition persists, contact your local Schneider Electric representative.								

## Module Characteristics

### Presentation

Module-specific characteristics	
Description	Electronic housing maximum 24 poles, with locking latch mounting
Mounting	DIN rail mounting with locking latch
Safety-related input (number / description)	8 /  Input type 3 according to EN 61131-2. Maximum resistance 1.2 kΩ.
Restart input (optional to status outputs) (number / description)	4 /  EDM (External Device Monitoring) type 3 according to EN 61131-2. Maximum resistance 1.2 kΩ. Possible automatic restart function or manual operation with restart pushbutton.
Status outputs (optional to restart input) (number / description)	4 /  SIL 1/PL c in accordance with standard EN 61508:2010. Maximum current per output: 100 mA, nominal voltage 24 Vdc.
Test output (number / description)	4 /

Module-specific characteristics	
	For cross circuit/short circuit monitoring, maximum current 100 mA, nominal voltage 24 Vdc.
Solid-state safety-related output (OSSD) (number / description)	4 / solid-state safety-related outputs PNP active high <ul style="list-style-type: none"> <li>• Interface type C class 3 (ZVEI CB24I Ed.2)</li> <li>• The outputs are able to supply:                             <ul style="list-style-type: none"> <li>◦ In the ON condition: <math>U_v - 0.6 V \dots U_v</math> where <math>U_v = 24 V_{dc} \pm 20\%</math></li> <li>◦ In the OFF condition: <math>0 \dots 2 V_{rms}</math> (root mean square)</li> </ul> </li> <li>• The maximum load current of 400 mA (per OSSD) corresponds to a minimum resistive load of 60 Ω.                             <ul style="list-style-type: none"> <li>◦ The maximum capacitive load is 0.82 μF.</li> <li>◦ The maximum inductive load is 2 mH.</li> </ul> </li> <li>• Test pulses are used to detect short circuits and interruptions of wires. The switch-off test pulse interval is every 600 ms, the maximum test pulse duration is 120 μs.</li> </ul>
Probability of Dangerous Failure per Hour (PFHd)	1.29E-08
Mean Time to Dangerous Failure (MTTFd) in years	168
Connection to expansion modules	5-way backplane expansion
Weight	0.150 kg (5.29 oz)

**NOTE:** For the characteristics common to all modules, refer to General Characteristics, page 24.

**⚠ DANGER**

**FIRE HAZARD**

Use only the correct wire sizes for the maximum current capacity of the I/O channels and power supplies.

**Failure to follow these instructions will result in death or serious injury.**

**⚠ WARNING**

**UNINTENDED EQUIPMENT OPERATION**

Do not exceed any of the rated values specified in the characteristics tables.

**Failure to follow these instructions can result in death, serious injury, or equipment damage.**

To achieve Performance Level PL e, according to standard EN 13849-1, the OSSD safety-related outputs must be independent.

Reduce Common Cause Failures (CCF) of OSSD safety-related outputs by separating cable paths (refer to ISO 13849-2 for event exclusion).

**⚠ WARNING**

**UNINTENDED EQUIPMENT OPERATION**

Run single channel, dual wiring in separate cabling.

**Failure to follow these instructions can result in death, serious injury, or equipment damage.**

# XPSMCMEN••••(G) Speed Monitoring Expansion Modules

## Modules and Functional Description

### Presentation

The XPSMCMEN0200(G), XPSMCMEN0100HT(G), XPSMCMEN0200HT(G), XPSMCMEN0100SC(G), XPSMCMEN0200SC(G), XPSMCMEN0100TT(G), and XPSMCMEN0200TT(G) are speed monitoring expansion modules for zero speed, maximum speed, speed range and direction monitoring. In addition, you can configure up to four speed thresholds for each axis being monitored.

The XPSMCMEN0200(G), XPSMCMEN0100HT(G), XPSMCMEN0200HT(G), XPSMCMEN0100SC(G), XPSMCMEN0200SC(G), XPSMCMEN0100TT(G), and XPSMCMEN0200TT(G) modules are configured with the XPSMCMCP0802(G), XPSMCMC10804(G) or XPSMCMC10804E(G) Modular Safety Controller.

The XPSMCMEN0200(G) module provides two safety-related inputs for proximity sensors. The XPSMCMEN0100HT(G) and XPSMCMEN0200HT(G) modules provide two proximity sensor inputs and one or two channels respectively for monitoring of safety-related HTL encoders. The XPSMCMEN0100SC(G) and XPSMCMEN0200SC(G) modules provide two proximity sensor inputs and one or two channels respectively for monitoring of safety-related Sin/Cos encoders. The XPSMCMEN0100TT(G) and XPSMCMEN0200TT(G) modules provides two proximity sensor inputs and one or two channels respectively for monitoring of safety-related TTL encoders.

**NOTE:** The encoders must be mounted according to EN 61800-5-2 to the shaft of the motor.

The modules are configured using SoSafe Configurable.

The expansion module supports two inputs `NODE_ADDR0` and `NODE_ADDR1` which are used to set a physical address to the module:

	<b>NODE_ADDR0 (Terminal 2)</b>	<b>NODE_ADDR1 (Terminal 3)</b>
NODE 0	0 (or not connected)	0 (or not connected)
NODE 1	24 Vdc	0 (or not connected)
NODE 2	0 (or not connected)	24 Vdc
NODE 3	24 Vdc	24 Vdc

**NOTE:** Do not use the same physical address for two units of the same module reference.  
**NOTE:** The LEDs **ADDR 1** and **ADDR 0** correspond to the `NODE_ADDR1` and `NODE_ADDR0` in this table respectively.  
**NOTE:** The node address wiring must match the configuration settings.

## Connector Designations

### XPSMCMEN••••(G) Modules Connector Designations

Terminal	Signal	LED	Type	Description	Operation
1	24 VDC	PWR	–	24 Vdc power supply	–
2	<code>NODE_ADDR0</code>	ADDR0	Input	Node selection	Input type 3 according to EN 61131-2. Maximum resistance 1.2 kΩ.
3	<code>NODE_ADDR1</code>	ADDR1			
4	0 VDC	PWR	–	0 Vdc power supply	–

Terminal	Signal	LED	Type	Description	Operation
5	PROXY1_24V	PROX1	Output	PROXIMITY 1 connections	Maximum current 100 mA
6	PROXY1_REF				Power supply 0 Vdc to PROXY1
7	PROXY1_IN1 (3-wire)		Input		PROXY1 Input_1 for NO or NC contact
8	PROXY1_IN2 (4-wire)				PROXY1 Input_2 for NO or NC contact
9	PROXY2_24V	PROX2	Output	PROXIMITY 2 connections	Maximum current 100 mA
10	PROXY2_REF				Power supply 0 Vdc to PROXY2
11	PROXY2_IN1 (3-wire)		Input		PROXY2 Input_1 for NO or NC contact
12	PROXY2_IN2 (4-wire)				PROXY2 Input_2 for NO or NC contact
13	N.C.	-	-	not connected	-
14					
15					
16					

**⚠ WARNING**

**UNINTENDED EQUIPMENT OPERATION**

Do not connect wires to unused terminals and/or terminals indicated as "No Connection (N.C.)" or Not Connected.

**Failure to follow these instructions can result in death, serious injury, or equipment damage.**

Encoder connections with RJ45 connector (modules XPSMCMEN0100HT(G), XPSMCMEN0200HT(G), XPSMCMEN0100SC(G), XPSMCMEN0200SC(G), XPSMCMEN0100TT(G), and XPSMCMEN0200TT(G)):

The diagram illustrates the pin configurations for three different connector types: a 25-pin D-sub connector (pins 8, 7, 6, 5, 4, 3, 2, 1), a 15-pin D-sub connector (pins 1, 2, 3, 4, 5, 6, 7, 8), and an RJ45 connector (pins 1, 2, 3, 4, 5, 6, 7, 8). To the right, an EIA/TIA-568A wiring diagram shows the color coding for the RJ45 connector: Pin 1 (green-white), Pin 2 (green), Pin 3 (orange-white), Pin 4 (blue), Pin 5 (blue-white), Pin 6 (orange), and Pin 7 (brown-white).

Pin	Color	XPSMCMEN0-00TT	XPSMCMEN0-00HT	XPSMCMEN0-00SC
1	green - white	5 Vdc <sup>(1)</sup>	not used	not used
2	green	0 Vdc	0 Vdc	0 Vdc
3	orange - white	not used	not used	not used
4	blue	A	A	A (Sin+)
5	blue-white	/A	/A	/A (Sin-)
6	orange	not used	not used	not used
7	brown-white	B	B	B (Cos+)

Pin	Color	XPSMCMEN0-00TT	XPSMCMEN0-00HT	XPSMCMEN0-00SC
8	brown	/B	/B	/B (Cos-)

(1) This pin is not the power supply of the TTL-encoder, which must be supplied separately. The pin needs to be connected for the speed monitoring module to detect the presence of a TTL-encoder.

For more information refer to the *Encoder Splitter Cables*, page 157.

## LED Indicators

### Front-Face View

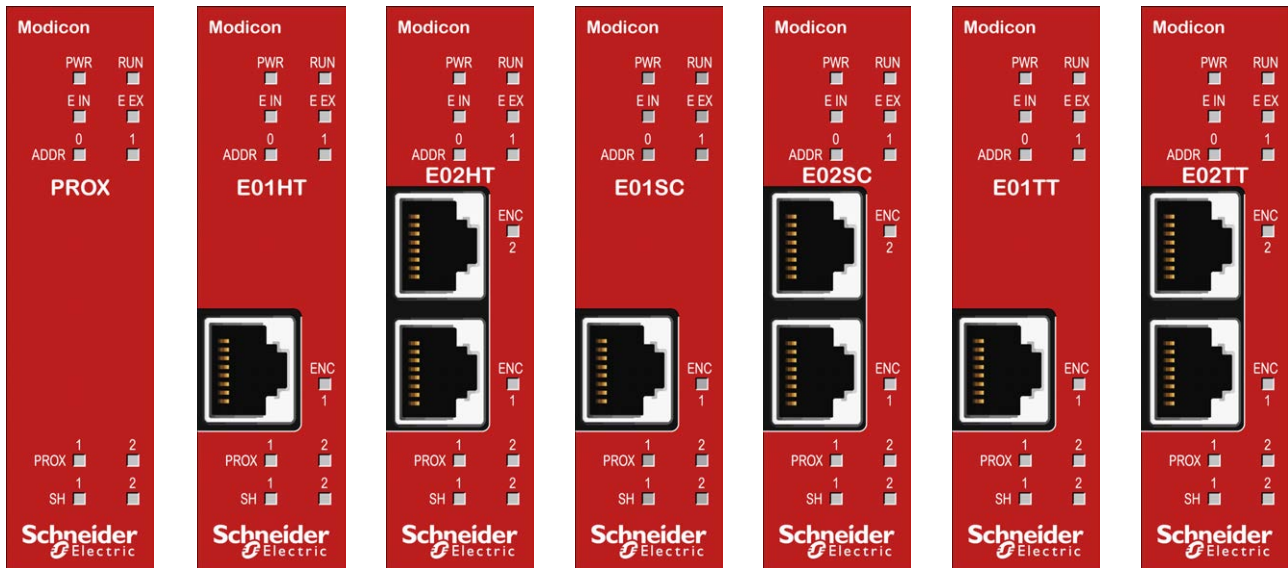

## Operation States

The following table describes the indication of operation states of the XPSMCMEN••••(G) by means of the LEDs. The description assumes that the power LED (**PWR**) is ON:

RUN green	E IN red	E EX red	ADDR 0...1 orange	ENC <sup>(1)</sup> yellow	PROX 1...2 yellow	SH 1...2 yellow	Meaning
ON	ON	ON	ON	ON	ON	ON	Power on - initial test
OFF = awaiting initialization	OFF	OFF	Encoded Node address, page 144	ON Encoder connected and operative	ON Proximity sensor connected and operative	OFF = Axis in normal speed range	Normal operation
Flashing = no inputs or outputs configured						Flashing = Axis in overspeed	
ON = inputs or outputs configured						ON = Axis in Standstill	

(1) The **ENC** LED indicator is not present on XPSMCMEN0200 and XPSMCMEN0200G.

## Troubleshooting

The following table describes the indication of detected errors of the XPSMCMEN••••(G) by means of the LEDs. The description assumes that the power LED (**PWR**) is ON:

Detected error	RUN green	E IN red	E EX red	ADDR 0...1 orange	ENC <sup>(1)</sup> yellow	PROX 1...2 yellow	SH 1...2 yellow	Solution
Internal error detected.	OFF	2 or 3 flashes	OFF	Encoded Node address, page 144	OFF			Product non serviceable <sup>(2)</sup> .
Compatibility error detected.	OFF	5 flashes	OFF		OFF			Firmware version not compatible with the controller <sup>(2)</sup> .
Encoder configured but not connected.	OFF	ON	3 flashes		OFF			Connect encoder to the module.  Verify input frequency is in range.
Proximity sensor inoperative.	OFF	OFF	ON		OFF	Flashes 2 sec.	OFF	Change the proximity sensor.
Proximity sensor configured but not connected.	OFF	OFF	3 flashes		OFF	Flashes 0.5 sec.	OFF	Connect proximity to the module.  Verify input frequency is in range.
Two units of the same module reference detected with the same node address.	OFF	5 flashes			OFF			Modify the unit node address, page 144.
Error detected on node detection circuit.	OFF	OFF	OFF	3 flashes	OFF	OFF	Flashes	Product non serviceable <sup>(2)</sup> .

(1) The **ENC** LED indicator is not present on XPSMCMEN0200 and XPSMCMEN0200G.  
 (2) If the condition persists, contact your local Schneider Electric representative.

## Troubleshooting Speed Monitoring

The following table describes the indication of detected errors by means of the LEDs. The description assumes that the power LED (**PWR**) is ON:

Detected error	RUN green	E IN red	E EX red	ADDR 0...1 orange	ENC <sup>(1)</sup> yellow	PROX 1...2 yellow	SH 1...2 yellow	Solution
Encoder internal error detected.	OFF	3 flashes	OFF	–	3 flashes	OFF	OFF	Change the encoder <sup>(2)</sup> .
Proximity internal error detected.	–	3 flashes	OFF	–	–	3 flashes	–	Change the proximity sensor <sup>(2)</sup> .
Error detected on node detection circuit.	OFF	3 flashes	OFF	3 flashes	OFF	OFF	OFF	Product non serviceable <sup>(2)</sup> .

(1) The **ENC** LED indicator is not present on XPSMCMEN0200 and XPSMCMEN0200G.  
 (2) If the condition persists, contact your local Schneider Electric representative.

## Module Characteristics

### Presentation

Module-specific characteristics	XPSMCMEN0200/ XPSMCMEN0200G	XPSMCMEN0100HT(G) XPSMCMEN0200HT(G)	XPSMCMEN0100SC(G) XPSMCMEN0200SC(G)	XPSMCMEN0100TT(G) XPSMCMEN0200TT(G)
Encoder interface	none	HTL	Sin/Cos	TTL
Encoder input signals electrically insulated in accordance with EN 61800-1	none	<ul style="list-style-type: none"> <li>Rated insulation voltage 250 V</li> <li>Overvoltage category II</li> <li>Rated impulse withstand voltage 4.00 kV</li> </ul>		

Module-specific characteristics	XPSMCMEN0200/ XPSMCMEN0200G	XPSMCMEN0100HT(G) XPSMCMEN0200HT(G)	XPSMCMEN0100SC(G) XPSMCMEN0200SC(G)	XPSMCMEN0100TT(G) XPSMCMEN0200TT(G)
	Maximum number of axis	2		
Zero speed / maximum speed frequency gap	> 10 Hz			
Minimum gap between thresholds (with threshold >1)	> 5 %			
Maximum number of encoders	0	1 on XPSMCMEN0100TT(G), XPSMCMEN0100HT(G), XPSMCMEN0100SC(G) 2 on XPSMCMEN0200TT(G), XPSMCMEN0200HT(G), XPSMCMEN0200SC(G)		
Maximum encoder frequency	-	300 kHz	500 kHz	500 kHz
Encoder adjustable threshold range	-	1 Hz to 450 kHz		
Encoder connections	-	RJ45		
Maximum number of proximity sensors	2			
Maximum proximity sensors frequency	5 kHz			
Maximum output current to proximity sensor	100 mA, nominal voltage 24 Vdc (terminals 5 and 9)			
Proximity adjustable threshold range	1 Hz to 4 kHz			
Zero speed/Maximum speed frequency gap	>10 Hz			
Minimum gap between thresholds (with threshold >1)	>5 %			
Proximity sensors connections	Terminal blocks			
Proximity sensors type	2x PNP or NPN - 3/4 wires			
PFHd XPSMCMEN01•	-	8.2E-9	9.43E-9	8.58E-9
PFHd XPSMCMEN02•	7.48E-9	8.92E-9	1.14E-8	9.68E-9
Mean Time to Dangerous Failure (MTTFd) in years XPSMCMEN01	-	326	241	294
Mean Time to Dangerous Failure (MTTFd) in years XPSMCMEN02	-	270	171	229
Weight	0.12 kg (4.2 oz)			

**NOTE:** For the characteristics common to all modules, refer to General Characteristics, page 24.

## ⚠ DANGER

### FIRE HAZARD

Use only the correct wire sizes for the maximum current capacity of the I/O channels and power supplies.

**Failure to follow these instructions will result in death or serious injury.**

<b>▲ WARNING</b>
<p><b>UNINTENDED EQUIPMENT OPERATION</b></p> <p>Do not exceed any of the rated values specified in the characteristics tables.</p> <p><b>Failure to follow these instructions can result in death, serious injury, or equipment damage.</b></p>

<b>▲ WARNING</b>
<p><b>UNINTENDED EQUIPMENT OPERATION</b></p> <ul style="list-style-type: none"> <li>• Make sure your sensing setup is suitable to generate consistent signals, especially at higher rotational speeds, when using proximity sensors.</li> <li>• Follow all application guidelines of the sensor manufacturer.</li> </ul> <p><b>Failure to follow these instructions can result in death, serious injury, or equipment damage.</b></p>

The following table describes the behavior of the system based on the speed monitoring functions:

Speed monitoring function blocks	Maximum speed	Zero speed	Speed range
Defined safe state	If speed exceeds the maximum speed limit resulting in the deactivation of outputs associated with function.	If Zero speed not achieved resulting in outputs associated with function not being activated.	If speed exceeds the upper or lower speed limits resulting in the deactivation of outputs associated with function.

## XPSMCMCO0000S1(G) and XPSMCMCO0000S2(G) Communication Expansion Modules

### Communication Expansion Modules

#### Presentation

The XPSMCMCO0000S•(G) are communication expansion modules (transmitter and receiver) which allow the connection of XPSMCM• Modular Safety Controller with expansion modules placed remotely ( $\leq 50$  m/ $\leq 164$  ft). Up to six islands can be created using the communication modules with a total length of 250 m (820.2 ft) and a maximum of 50 m (164 ft) between two communication modules. The system response time does not change with the use of the communication modules.

Using RS-485 shielded cable, page 156, two XPSMCMCO0000S•(G) modules placed at the desired distance can be linked together thus joining the expansion modules to the controller. Each XPSMCMCO0000S2(G) module has two independent connection channels; the connection of two XPSMCMCO0000S2(G) modules can be accomplished by wiring either channel.

The XPSMCMCO0000S1(G) module has one channel and must be connected as the first (remote) or last (local) module.

## Connector Designations and Cable

### XPSMCMCO0000S•(G) Modules Connector Designations

Terminal	Signal		Description	Cable connections
	XPSMCMC-O0000S1	XPSMCMC-O0000S2		
1	24 VDC		24 Vdc power supply	-
2	N.C.		-	
3	Shielding CH1		-	
4	0 VDC		0 Vdc power supply	
5	N.C.	N.C.	-	
6			-	
7		Shielding CH2	-	
8		N.C.	-	
9	CH1-A		Be sure to connect to the corresponding terminals of the remote XPSMCMCO0000S•(G): <ul style="list-style-type: none"> <li>• A &lt;-&gt; A</li> <li>• B &lt;-&gt; B</li> <li>• C &lt;-&gt; C</li> <li>• D &lt;-&gt; D</li> <li>• SHIELDING &lt;-&gt; SHIELDING</li> </ul> You can also connect CH1 with CH2 (XPSMCMCO0000S2).	First pair twisted conductors
10	CH1-B			Second pair twisted conductors
11	CH1-C			
12	CH1-D			
13	N.C.	CH2-A		First pair twisted conductors
14		CH2-B		
15		CH2-C		Second pair twisted conductors
16		CH2-D		

### RS485 Cable Technical Data

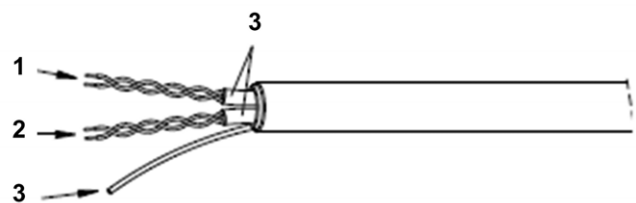

1 First pair  
2 Second pair  
3 Shielding

Element	Description/Value
Conductors	2 pairs of twisted conductors with shielding
Nominal impedance	120 Ω
Nominal capacitance	<42 pF/m
Nominal resistance	<95 Ω/m

## Wiring Example RS485 Island Expansion

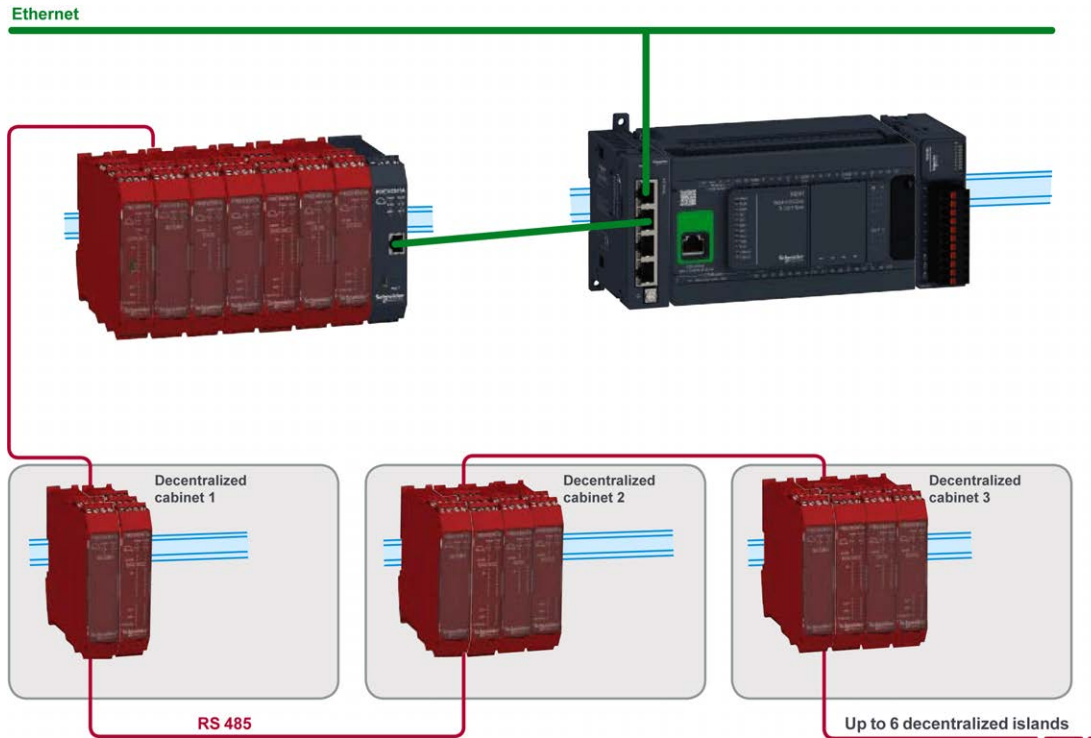

## LED Indicators

### Front-Face View



## Operation States

The following table describes the indication of operation states of the XPSMCMCO0000S•(G) by means of the LEDs. The description assumes that the power LED (**PWR**) is ON:

<b>RUN</b> <b>green</b>	<b>E IN</b> <b>red</b>	<b>E EX</b> <b>red</b>	<b>Meaning</b>
ON	ON	ON	Power on - initial test
OFF = awaiting initialization	OFF	OFF	Normal operation
Flashing = no inputs or outputs configured			
ON = inputs or outputs configured			
<sup>1</sup> For more information, refer to Error Codes (see Modular Safety Controller, Library and Programming Guide).			

## Troubleshooting

The following table describes the indication of detected errors of the XPSMCMCO0000S•(G) by means of the LEDs. The description assumes that the power LED (**PWR**) is ON:

<b>Detected error</b>	<b>RUN</b> <b>green</b>	<b>E IN</b> <b>red</b>	<b>E EX</b> <b>red</b>	<b>Solution</b>
Internal error detected	OFF	Flashing	OFF	Refer to Error Codes (see Modular Safety Controller, Library and Programming Guide).
External wiring error detected	OFF	OFF	ON	Verify connections.

## Module Characteristics

### Presentation

<b>Module-specific characteristics</b>	<b>XPSMCMCO0000S1</b>	<b>XPSMCMCO0000S2</b>
Reference description	Electronic housing maximum 8 poles, with locking latch mounting	Electronic housing maximum 16 poles, with locking latch mounting
Connection channels	1	2
Maximum connections	6	
Maximum cable length between communication modules	<50 m (164 ft) per section	
Weight	0.12 kg (4.2 oz)	
Probability of a dangerous failure per hour (PFHd)	1.13 x 10 <sup>-8</sup>	1.31 x 10 <sup>-8</sup>

**NOTE:** For the characteristics common to all modules, refer to General Characteristics, page 24.

# Accessories

## What's in This Chapter

USB/Mini B USB or USB/USB-C Configuration Cable .....	153
Configuration Memory Card .....	153
Backplane Expansion Connector .....	155
RS485 Cable .....	156
Encoder Splitter Cables for PacDrive M.....	157
Encoder Splitter Cables for Lexium 32, Lexium 52 and Lexium 62.....	158
Covers for Backplane Connectors .....	161
Encoder Modules RJ45 support.....	161

## USB/Mini B USB or USB/USB-C Configuration Cable

### Presentation

The XPSMCMCP0802(G) or XPSMCMC10804(G) (firmware version less than 8.0.0 ) Modular Safety Controller and fieldbus communication modules have a dedicated USB 2.0 port for connection to a PC and SoSafe Configurable.

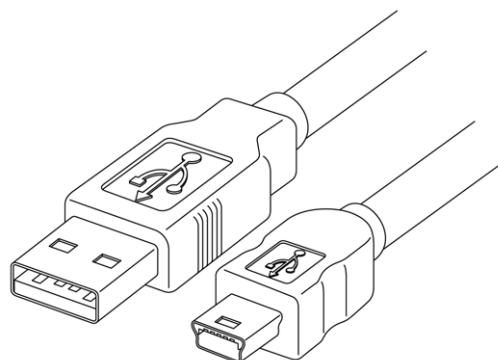

A USB/Mini B USB configuration cable is available as an accessory under the reference **TCSXCNAMUM3P**. A commercially available standard USB/Mini B USB cable with a maximum length of 3 meters can also be used for configuration.

#### USB/USB-C Configuration cable

The XPSMCMC10804(G) (firmware version 8.0.0 or greater) or XPSMCMC10804E(G) Modular Safety Controller have a dedicated USB 2.0 port for connection to a PC and SoSafe Configurable.

A commercially available standard USB/USB-C cable with a maximum length of 3 meters can be used for configuration.

## Configuration Memory Card

### XPSMCMME0000 Memory Card Presentation

The XPSMCMME0000 memory card can be installed in the Modular Safety Controller and is used to save/restore the hardware/software configuration.

The XPSMCMME0000 memory card is specific to the XPSMCMCP0802(G), XPSMCMC10804(G) and XPSMCMC10804E(G) controllers, and therefore, only this reference can be used within the controller.

The memory card is only written to using SoSafe Configurable software during download of the configuration.

If the memory card is inserted without any configuration, the XPSMCM• controller continues to operate with the previously loaded configuration held in its non-volatile memory.

If a memory card is inserted with a configuration which does not match the one contained in the controller, the configuration on the memory card will overwrite that which is in the controller, erasing definitively the previous configuration therein. That is, all data (password included) previously contained in XPSMCM• controller will be overwritten.

## **NOTICE**

### **LOSS OF DATA**

Ensure that the existing configuration in the controller is saved before inserting a memory card.

**Failure to follow these instructions can result in equipment damage.**

**Multiple load function:** To perform the configuration of several XPSMCM• Modular Safety Controllers without using a PC and the USB connector, you can save the desired configuration on a single memory card and then use it to download data on the XPSMCM• Modular Safety Controllers.

**Restore function:** If the XPSMCM• controller is damaged, replace it with a new and respective XPSMCM• Modular Safety Controller. When the memory card has been used, remove the memory card from the damaged controller, insert the memory card in the new XPSMCM• controller, and power the Modular Safety Controller. The configuration of the memory card is automatically loaded into the new controller.

## XPSMCMME0000 Memory Card Insertion

## **⚠ WARNING**

### **UNINTENDED EQUIPMENT OPERATION**

- First remove power from the Modular Safety Controller before attempting to insert or remove the memory card.
- Each time the memory card is used, carefully verify that the loaded configuration is the one that was intended for the particular system.
- Conduct a full functional test (see *Validation* in the *Modular Safety Controller User Guide*) of the system, composed of the Modular Safety Controller plus all input and output hardware connected to it, after using the memory card to overwrite your safety-related application.

**Failure to follow these instructions can result in death, serious injury, or equipment damage.**

The memory card can be inserted into the rear of the XPSMCM• Modular Safety Controller.

Step	Action
1	Remove all power from the controller before inserting or removing the memory card. <b>NOTE:</b> Before you insert the memory card for the first time, remove the protective label on the rear side of the controller. (See item 1 in graphic below).
2	Insert the memory card with the product label facing to the right. (See item 2 in graphic below). <b>NOTE:</b> If the memory card is oriented incorrectly, the memory card may be damaged or will not be identified.
3	Insert the card in the slot in the rear panel of the controller. 

## XPSMCMME0000 Memory Card Characteristics

Memory card-specific characteristics	
Description	8 poles connector
Memory card size	250 MB
Ambient operating temperature	-10...+55 °C (14...131 °F)
Storage temperature	-20...+85 °C (-4...185 °F)
Relative humidity	10...95%
Maximum operation altitude	2000 m (6562 ft)
Dimensions	21.5 x 18 x 2 mm (0.85 x 0.7 x 0.079 in.)
Weight	0.12 kg (4.2 oz)

## Backplane Expansion Connector

### Overview

The XPSMCMCN0000SG backplane expansion connector allows you to add expansion input/output and communication modules to the XPSMCM• Modular Safety Controller. The expansion modules that require one XPSMCMCN0000SG connector are delivered with the connector. If, for the purposes of your system, you need to add expansion modules to the controller, you need to order an extra XPSMCMCN0000SG connector for the XPSMCM• controller.

To connect the Modular Safety Controller and expansion modules:

<p>1. Connect the same number of backplane expansion connectors as the number of modules to be installed.</p>	
<p>2. Fix the connectors to the DIN 35 mm (EN ISO 5022) rail, connecting them on to the rail at the top first).</p>	
<p>3. Attach the modules to the rail, arranging the contacts on the base of the module on the respective connector. Press the module until it snaps into place.</p>	
<p>4. To remove a module, use a screwdriver to pull down the locking latch on the back of the module; then lift the module upwards and pull.</p>	

<b>Backplane expansion connector-specific characteristics</b>	
Connection to expansion modules	5-way backplane expansion
Ambient operating temperature	-10...+55 °C (14...131 °F)
Storage temperature	-20...+85 °C (-4...185 °F)
Relative humidity	10...95%
Maximum operation altitude	2000 m (6562 ft)
Dimensions	36.5 x 29.2 x 20.5 mm (1.44 x 1.15 x 0.8 in.)
Weight	5.2 g (0.18 oz)

## RS485 Cable

### RS485 Cable Characteristics

RS485 serial interface shielded cables are used between the Bus expansion communications modules to create up to six decentralized safety-related islands with a maximum of 50 meters (164.04 ft) between each island.

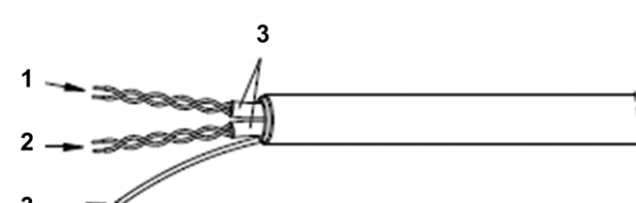

1 First pair  
2 Second pair  
3 Shielding

Element	Description/Value
Conductors	2 pairs of twisted conductors with shielding
Nominal impedance	120 Ω
Nominal capacitance	<42 pF/m
Nominal resistance	<95 Ω/m

The following cables are compatible with the Modular Safety Controller system:

Reference	Length
TSXSCMCN010	10 m / 32.81 ft
TSXSCMCN025	25 m / 82.02 ft
TSXSCMCN050	50 m / 164.04 ft

## Encoder Splitter Cables for PacDrive M

### Description

An encoder splitter cable is used to split the motor encoder feedback signal. One signal is directed to the drive and one to the RJ45 connection of the safety-related speed monitoring module. The cables are unique to the specific drive system due to the wiring used. Encoder splitter cables are available in 1, 3 and 5 meters (3.28, 9.84 and 16.40 ft) lengths.

### Encoder Splitter Cable

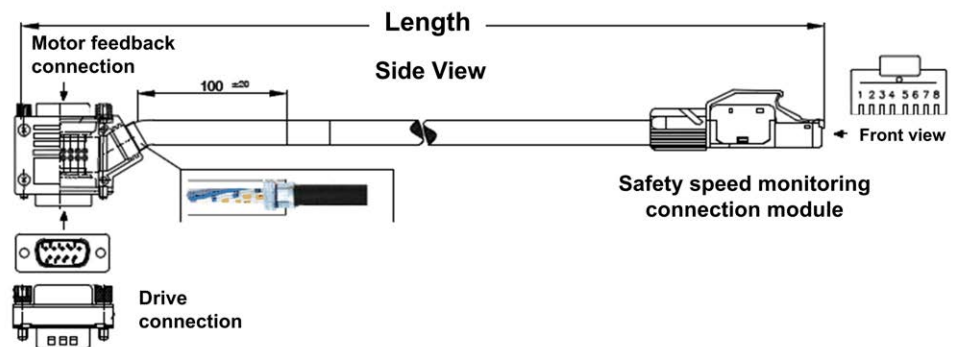

### Encoder Splitter Terminal Designation

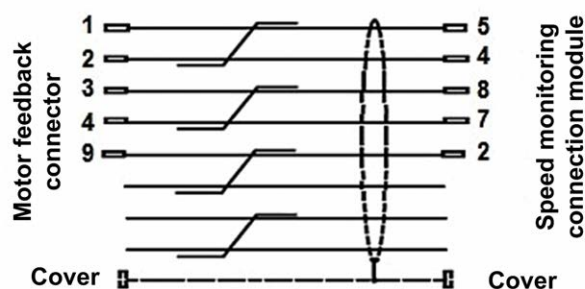

Motor feedback connector:

Pin	Wire color
1	Blue/White
2	Blue
3	Brown
4	White/Brown
9	Green
Not used	White/Green

Pin	Wire color
Not used	Orange
Not used	White/Orange
Cover	Shield

Speed monitoring connection module:

Pin	Wire color	Function
5	Blue/White	/A (Sin-)
4	Blue	A (Sin+)
8	Brown	/B (Cos-)
7	White/Brown	B (Cos+)
2	Green	0 V
Not used	White/Green	Not used
Not used	Orange	Not used
Not used	White/Orange	Not used
Cover	Shield	GND

## Encoder Splitter Characteristics

Encoder splitter cable characteristics:

Parameter	Value
Ambient operating temperature	-10...+55 °C (14...131 °F)
Storage temperature	-20...+85 °C (-4...185 °F)
Relative humidity	10...95%
Maximum operation altitude	2000 m / 6562 ft

## Encoder Splitter Cable References

Encoder splitter cable references:

Reference	Length
TSXESPPM001	1 m / 3.28 ft
TSXESPPM003	3 m / 9.84 ft
TSXESPPM005	5 m / 16.40 ft

## Encoder Splitter Cables for Lexium 32, Lexium 52 and Lexium 62

### Description

An encoder splitter cable is used to split the motor encoder feedback signal. One signal is directed to the drive and one to the RJ45 connection of the safety-related speed monitoring module. The cables are unique to the specific drive system due

to the wiring used. Encoder splitter cables are available in 1, 3 and 5 meters (3.28, 9.84 and 16.40 ft) lengths.

## Encoder Splitter Cable

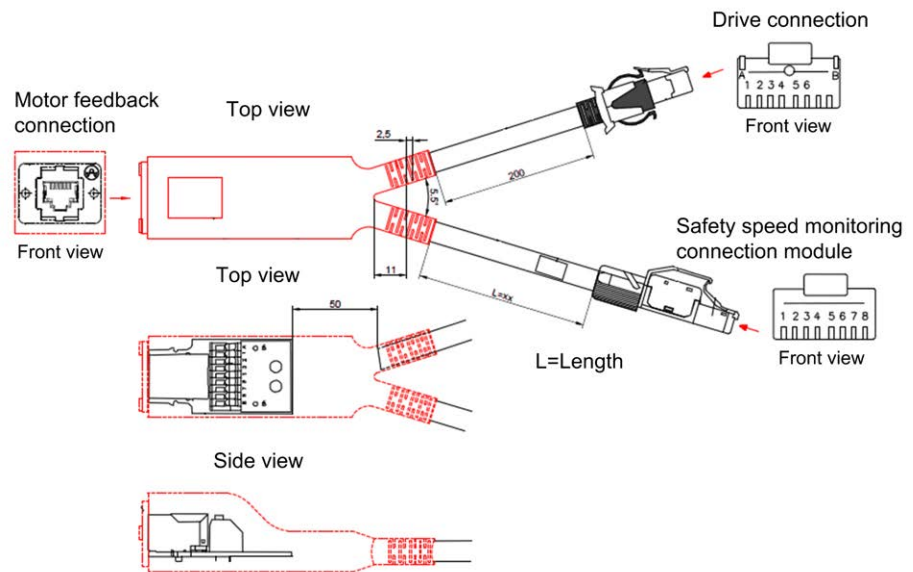

## Encoder Splitter Cable - Terminal Designation

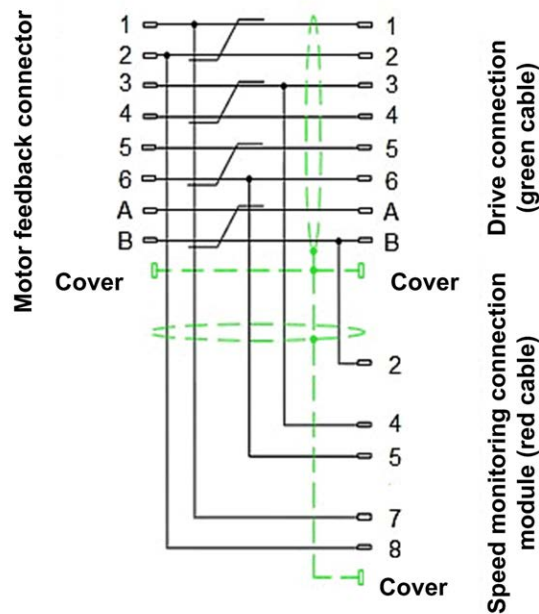

Motor feedback connector:

Pin	Wire color
1	Green
2	Yellow
3	White
4	Gray
5	Pink
6	Brown

Pin	Wire color
A	Red
B	Blue
Cover	Shield

Drive connection (green cable):

Pin	Wire color	Function
1	Green	B (Cos+)
2	Yellow	/B (Cos-)
3	White	A (Sin+)
4	Gray	RS 485+
5	Pink	RS 485-
6	Brown	/A (Sin-)
A	Red	7-12 V
B	Blue	0 V
Cover	Shield	GND

Speed monitoring connection module (red cable):

Pin	Wire color	Function
1	—	Not used
2	Green	0 V
3	—	Not used
4	Blue	A (Sin+)
5	Blue/white	/A (Sin-)
6	—	Not used
7	White/brown	B (Cos+)
8	Brown	/B (Cos-)
Cover	Shield	GND

## Lexium 32, Lexium 52 and Lexium 62 Splitter Cable Characteristics

Encoder splitter cable characteristics for Lexium 32, Lexium 52 and Lexium 62:

Parameter	Value
Ambient operating temperature	-10...+55 °C (14...131 °F)
Storage temperature	-20...+85 °C (-4...185 °F)
Relative humidity	10...95%
Maximum operation altitude	2000 m / 6562 ft

## Lexium 32, Lexium 52 and Lexium 62 Splitter Cable References

Lexium 32, Lexium 52 and Lexium 62 splitter cable references:

Reference	Length
TSXESPP3001	1 m / 3.28 ft
TSXESPP3003	3 m / 9.84 ft
TSXESPP3005	5 m / 16.40 ft

## Covers for Backplane Connectors

### Description

It allows you to cover the backplane connector:

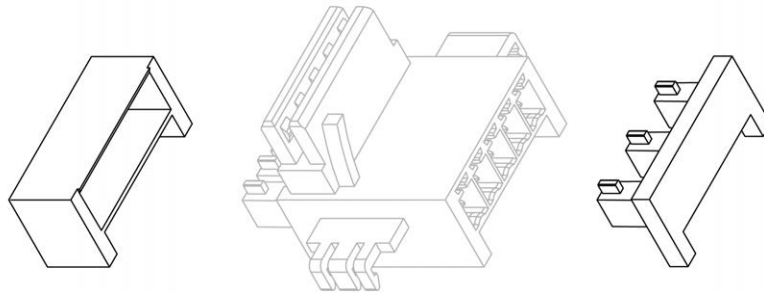

Covers for backplane connectors-specific characteristics:

Parameter	Value
Ambient operating temperature	-10...+55 °C (14...131 °F)
Storage temperature	-20...+85 °C (-4...185 °F)
Relative humidity	10...95%

## Encoder Modules RJ45 support

### Description

It is a plastic support for RJ45 encoder connector:

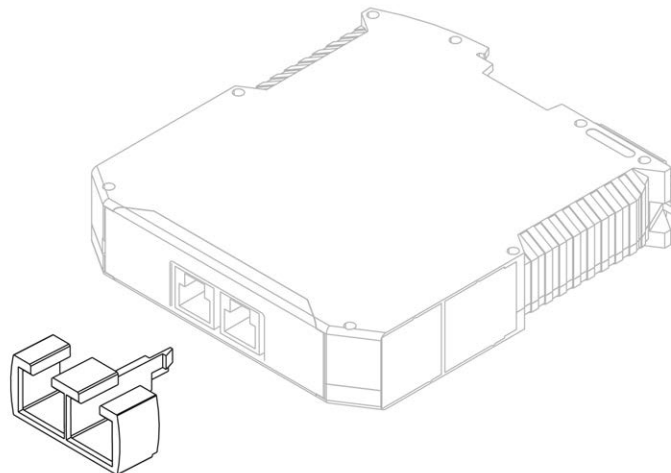

Encoder modules RJ45 support-specific characteristics:

<b>Parameter</b>	<b>Value</b>
Ambient operating temperature	-10...+55 °C (14...131 °F)
Storage temperature	-20...+85 °C (-4...185 °F)
Relative humidity	10...95%

# Index

## A

accessories	
XPSMCMCN0000CV .....	161
XPSMCMCN0000SP .....	161

## B

backplane connector	
XPSMCMCN0000SG .....	155

## C

controller	
XPSMCMC10804(G) .....	44
XPSMCMC10804E(G) .....	54
XPSMCMCP0802(G) .....	36

## I

inductive load, output protection	
output protection, inductive load .....	32

## M

memory card	
XPSMCMME0000 .....	153
module	
XPSMCMAI0200(G) .....	67
XPSMCMAI0400(G) .....	67
XPSMCMADI0800(G) .....	77
XPSMCMADI1200MT(G) .....	81
XPSMCMADI1600(G) .....	77
XPSMCMDO0002(G) .....	85
XPSMCMDO0004(G) .....	85
XPSMCMDO00042A(G) .....	92
XPSMCMDO0004S(G) .....	100
XPSMCMDO0008C1(G) .....	107
XPSMCMDO0016C1(G) .....	111
XPSMCMER0002(G) .....	116
XPSMCMER0004(G) .....	116
XPSMCMER0008(G) .....	116
XPSMCMMX0802(G) .....	131
XPSMCMMX0804(G) .....	136
XPSMCMRO0004(G) .....	124
XPSMCMRO0004DA(G) .....	124
modules	
XPSMCMCO0000S1(G) .....	149
XPSMCMCO0000S2(G) .....	149
XPSMCMEN••••(G) .....	144

## W

wiring .....	28
--------------	----

## X

XPSMCMAI0200(G)	
module .....	67
XPSMCMAI0400(G)	
module .....	67
XPSMCMC10804(G)	
controller .....	44

XPSMCMC10804E(G)	
controller .....	54
XPSMCMCN0000CV .....	161
XPSMCMCN0000SG	
backplane connector .....	155
XPSMCMCN0000SP .....	161
XPSMCMCO0000S1(G)	
modules .....	149
XPSMCMCO0000S2(G)	
modules .....	149
XPSMCMCP0802(G)	
controller .....	36
XPSMCMADI0800(G)	
module .....	77
XPSMCMADI1200MT(G)	
module .....	81
XPSMCMADI1600(G)	
module .....	77
XPSMCMDO0002(G)	
module .....	85
XPSMCMDO0004(G)	
module .....	85
XPSMCMDO00042A(G)	
module .....	92
XPSMCMDO0004S(G)	
module .....	100
XPSMCMDO0008C1(G)	
module .....	107
XPSMCMDO0016C1(G)	
module .....	111
XPSMCMEN••••(G)	
modules .....	144
XPSMCMER0002(G)	
module .....	116
XPSMCMER0004(G)	
module .....	116
XPSMCMER0008(G)	
module .....	116
XPSMCMME0000	
memory card .....	153
XPSMCMMX0802(G)	
module .....	131
XPSMCMMX0804(G)	
module .....	136
XPSMCMRO0004(G)	
module .....	124
XPSMCMRO0004DA(G)	
module .....	124

Schneider Electric  
35 rue Joseph Monier  
92500 Rueil Malmaison  
France

[www.se.com](http://www.se.com)

As standards, specifications, and design change from time to time, please ask for confirmation of the information given in this publication.

© 2026 Schneider Electric. All rights reserved.

EIO0000004000.03