

Lexium 62

Hardware Guide

Original instructions

EIO0000003738.02

02/2021



Legal Information

The Schneider Electric brand and any trademarks of Schneider Electric SE and its subsidiaries referred to in this guide are the property of Schneider Electric SE or its subsidiaries. All other brands may be trademarks of their respective owners.

This guide and its content are protected under applicable copyright laws and furnished for informational use only. No part of this guide may be reproduced or transmitted in any form or by any means (electronic, mechanical, photocopying, recording, or otherwise), for any purpose, without the prior written permission of Schneider Electric.

Schneider Electric does not grant any right or license for commercial use of the guide or its content, except for a non-exclusive and personal license to consult it on an "as is" basis. Schneider Electric products and equipment should be installed, operated, serviced, and maintained only by qualified personnel.

As standards, specifications, and designs change from time to time, information contained in this guide may be subject to change without notice.

To the extent permitted by applicable law, no responsibility or liability is assumed by Schneider Electric and its subsidiaries for any errors or omissions in the informational content of this material or consequences arising out of or resulting from the use of the information contained herein.

© 2021 Schneider Electric. All rights reserved.

Table of Contents

Safety Information	7
About the Book.....	8
Specific Safety Information.....	10
Product Related Information	10
Intended Use.....	15
Qualification of Personnel.....	17
System Overview	18
System Overview.....	18
Logic Motion Controller	19
Lexium 62 Power Supply.....	20
Lexium 62 Servo Drive	22
Lexium 62 DC Link Terminal and Lexium 62 DC Link Support Module.....	25
QR Code - Description	28
SH3 Servo Motor	29
MH3 Servo Motor.....	30
BMP Synchronous Motor.....	31
SinCos Encoder.....	33
Engineering	34
Electromagnetic Compatibility, EMC.....	34
Control Cabinet Planning.....	37
Degree of Protection (IP)	37
Mechanical and Climatic Environmental Conditions in the Control Cabinet	38
Using Cooling Units.....	39
Information about Wiring	40
General Information about Wiring	40
Cable Characteristics	41
Configuring and Coding the Cables	42
ESD Protection Measures.....	44
Conditions for UL / CSA Compliant Use	45
Fusing the Mains Connection	48
Mains Contactor.....	49
Mains Filter.....	50
Mains Line Reactor (Choke).....	51
Connection of the Lexium 62 Power Supply.....	52
Parallel Connection of Several Lexium 62 Power Supplies (LXM62PD84A11000).....	53
Wiring with Lexium 62 DC Link Terminal.....	56
Cable Selection Guidelines for Wiring With Lexium 62 DC Link Terminal	63
Leakage Current	67
Residual Current Operated Protective Device.....	68
Functional Safety.....	69
Process Minimizing Risks Associated with the Machine.....	69
Inverter Enable Function.....	71
Setup, Installation and Maintenance	78
Setup, Installation, and Maintenance - Wiring Verification	80

Application Proposals for Hardware Based Safety-Related Functions	83
Application Proposal for the Variants C/D/G Single-Channel Jumpered	84
Application Proposal for the Variants C/D/G Two-Channel with Protected Wiring	85
Application Proposal for the Variants C/D/G Two-Channel with Test Pulses	88
Application Proposal for the Variants C/D/G Two-Channel with External, Non-Safety-Related Diagnostic	89
Application Proposals for Software Based Safety-Related Function	90
Commissioning	93
Best Practices	94
Maintenance	96
Physical Environment	97
Safety Standards	98
Special Conditions	100
Increased Ambient Temperature	100
Low Air Pressure	101
Installation and Maintenance	102
Commissioning	102
Prerequisites for Commissioning	102
Preparing Commissioning	103
Preparing the Control Cabinet	104
Mounting	110
External Shield Connection on the Drive Module (Excluding LXM62DC13)	118
External Shield Connection on the Drive Module (Excluding LXM62DC13) Former Shield Plate	120
External Shield Connection on the Drive Module LXM62DC13	122
Strain Relief for Lexium 62 DC Link Terminal Connections	124
Maintenance, Repair, Cleaning, Replacement Equipment Inventory	127
Prerequisites for Maintenance, Repair, and Cleaning	127
Machine Repair	129
Cleaning	130
Replacement Equipment Inventory	131
Replacing Components and Cables	132
Prerequisites for Replacing Components and Cables	132
Component Replacement	135
Cable Replacement	138
Indicators and Control Elements	140
Indicators of the Lexium 62 Power Supply	140
Indicators of the Lexium 62 Servo Drive	143
Bus Bar Module LED Indicators on the Lexium 62 Power Supply, Lexium 62 Servo Drive, and Lexium 62 DC Link Support Module	146
Electrical Power Connections	147
Electrical Connections for the Lexium 62 Power Supply	147

Electrical Connections for the Lexium 62 Servo Drives.....	151
Electrical Connections for the Lexium 62 DC Link Support Module.....	165
Electrical Connections for the Lexium 62 DC Link Terminal	166
Technical Data	167
Standards and Regulations.....	167
Ambient Conditions	169
Mechanical and Electrical Data for the Lexium 62 Power Supply	171
Mechanical and Electrical Data for the Single Drives.....	173
Mechanical and Electrical Data for the Double Drives	178
Mechanical and Electrical Data for the Lexium 62 DC Link Terminal	182
Mechanical and Electrical Data for the Lexium 62 DC Link Support Module.....	184
Optional Accessory.....	185
5V Encoder Adapter.....	185
Overview	185
Technical Data	186
Electrical Connections and Dimensions	186
Wiring	188
Appendices	189
Disposal	190
Disposal.....	190
Glossary	191
Index	193

Safety Information

Important Information



Read these instructions carefully, and look at the equipment to become familiar with the device before trying to install, operate, service, or maintain it. The following special messages may appear throughout this documentation or on the equipment to warn of potential hazards or to call attention to information that clarifies or simplifies a procedure.



The addition of this symbol to a “Danger” or “Warning” safety label indicates that an electrical hazard exists which will result in personal injury if the instructions are not followed.



This is the safety alert symbol. It is used to alert you to potential personal injury hazards. Obey all safety messages that follow this symbol to avoid possible injury or death.

 DANGER
DANGER indicates a hazardous situation which, if not avoided, will result in death or serious injury.
 WARNING
WARNING indicates a hazardous situation which, if not avoided, could result in death or serious injury.
 CAUTION
CAUTION indicates a hazardous situation which, if not avoided, could result in minor or moderate injury.
NOTICE
NOTICE is used to address practices not related to physical injury.

Please Note

Electrical equipment should be installed, operated, serviced, and maintained only by qualified personnel. No responsibility is assumed by Schneider Electric for any consequences arising out of the use of this material.

A qualified person is one who has skills and knowledge related to the construction and operation of electrical equipment and its installation, and has received safety training to recognize and avoid the hazards involved.

About the Book

Document Scope

Read and understand the material contained in this manual before you work on the Lexium 62 Drive System for the first time. Take particular note of the chapter *Specific Safety Information*, page 10. Only those persons who meet the criteria described in *Qualification of Personnel*, page 17 are allowed to work with the Lexium 62 Drive System.

A copy of this manual must be available for personnel who work with the Lexium 62 Drive System.

This manual is to help you use the capabilities of the Lexium 62 Drive System safely and properly.

Follow the instructions within this manual to help:

- Reduce risks
- Reduce repair costs and downtime of the Lexium 62 Drive System
- Increase the service life of the Lexium 62 Drive System
- Increase reliability of the Lexium 62 Drive System

Validity Note

This document has been updated for the release of EcoStruxure™ Machine Expert V2.0.

The technical characteristics of the devices described in the present document also appear online. To access the information online, go to the Schneider Electric home page www.se.com/ww/en/download/.

The characteristics that are described in the present document should be the same as those characteristics that appear online. In line with our policy of constant improvement, we may revise content over time to improve clarity and accuracy. If you see a difference between the document and online information, use the online information as your reference.

For product compliance and environmental information (RoHS, REACH, PEP, EOL, etc.), go to www.se.com/ww/en/work/support/green-premium/.

Related Documents

Document title	Reference
EcoStruxure Machine Expert Programming Guide	EIO0000002854 (ENG) EIO0000002855 (FRE) EIO0000002856 (GER) EIO0000002857 (ITA) EIO0000002858 (SPA) EIO0000002859 (CHS)
LXM62LT00A01000 Lexium 62 DC Link Terminal, Instruction Sheet	NVE50846 (ENG);
SH3 Servo Motor - User Guide	0198441113987 (ENG);
MH3 Servo Motor - Motor Manual	0198441114042 (ENG);
BMP Synchronous Motor - Motor Manual	0198441113981 (ENG);

Terminology Derived from Standards

The technical terms, terminology, symbols and the corresponding descriptions in this manual, or that appear in or on the products themselves, are generally derived from the terms or definitions of international standards.

In the area of functional safety systems, drives and general automation, this may include, but is not limited to, terms such as *safety*, *safety function*, *safe state*, *fault*, *fault reset*, *malfunction*, *failure*, *error*, *error message*, *dangerous*, etc.

Among others, these standards include:

Standard	Description
IEC 61131-2:2007	Programmable controllers, part 2: Equipment requirements and tests.
ISO 13849-1:2015	Safety of machinery: Safety related parts of control systems. General principles for design.
EN 61496-1:2013	Safety of machinery: Electro-sensitive protective equipment. Part 1: General requirements and tests.
ISO 12100:2010	Safety of machinery - General principles for design - Risk assessment and risk reduction
EN 60204-1:2006	Safety of machinery - Electrical equipment of machines - Part 1: General requirements
ISO 14119:2013	Safety of machinery - Interlocking devices associated with guards - Principles for design and selection
ISO 13850:2015	Safety of machinery - Emergency stop - Principles for design
IEC 62061:2015	Safety of machinery - Functional safety of safety-related electrical, electronic, and electronic programmable control systems
IEC 61508-1:2010	Functional safety of electrical/electronic/programmable electronic safety-related systems: General requirements.
IEC 61508-2:2010	Functional safety of electrical/electronic/programmable electronic safety-related systems: Requirements for electrical/electronic/programmable electronic safety-related systems.
IEC 61508-3:2010	Functional safety of electrical/electronic/programmable electronic safety-related systems: Software requirements.
IEC 61784-3:2016	Industrial communication networks - Profiles - Part 3: Functional safety fieldbuses - General rules and profile definitions.
2006/42/EC	Machinery Directive
2014/30/EU	Electromagnetic Compatibility Directive
2014/35/EU	Low Voltage Directive

In addition, terms used in the present document may tangentially be used as they are derived from other standards such as:

Standard	Description
IEC 60034 series	Rotating electrical machines
IEC 61800 series	Adjustable speed electrical power drive systems
IEC 61158 series	Digital data communications for measurement and control – Fieldbus for use in industrial control systems

Finally, the term *zone of operation* may be used in conjunction with the description of specific hazards, and is defined as it is for a *hazard zone* or *danger zone* in the *Machinery Directive (2006/42/EC)* and *ISO 12100:2010*.

NOTE: The aforementioned standards may or may not apply to the specific products cited in the present documentation. For more information concerning the individual standards applicable to the products described herein, see the characteristics tables for those product references.

Specific Safety Information

Overview

This chapter contains important safety information regarding working with the Lexium 62 Drive System. The Lexium 62 system conforms to recognized technical safety regulations.

Product Related Information

Overview

Health and safety risks arising from the Lexium 62 Drive System have been reduced. However, residual risks remain, since the Lexium 62 Drive System works with electrical voltage and currents as well as movement.

If activities involve residual risks, a safety message is made at the appropriate points. This includes potential hazards that may arise, their possible consequences, and describes preventive measures to avoid the hazards.

Electrical Parts

⚠ DANGER

ELECTRIC SHOCK, EXPLOSION, OR ARC FLASH

- Disconnect all power from all equipment including connected devices prior to removing any covers or doors, or installing or removing any accessories, hardware, cables, or wires.
- Place a "Do Not Turn On" or equivalent hazard label on all power switches and lock them in the non-energized position.
- Wait 15 minutes to allow the residual energy of the DC bus capacitors to discharge.
- Measure the voltage on the DC bus with a properly rated voltage sensing device and verify that the voltage is less than 42.4 Vdc.
- Do not assume that the DC bus is voltage-free when the DC bus LED is off.
- Block the motor shaft to prevent rotation prior to performing any type of work on the drive system.
- Do not create a short-circuit across the DC bus terminals or the DC bus capacitors.
- Replace and secure all covers, accessories, hardware, cables, and wires and confirm that a proper ground connection exists before applying power to the unit.
- Use only the specified voltage when operating this equipment and any associated products.

Failure to follow these instructions will result in death or serious injury.

⚠ DANGER

ELECTRIC SHOCK, EXPLOSION, OR ARC FLASH

- Operate electrical components only with a connected protective ground (earth) cable.
- After the installation, verify the secure connection of the protective ground (earth) cable to all electrical devices to ensure that connection complies with the connection diagram.
- Before enabling the device, safely cover the live components to prevent contact.
- Do not touch the electrical connection points of the components when the module is energized.
- Provide protection against indirect contact.
- Connect and disconnect cables and terminals only after you have verified that the power has been removed from the system.
- Insulate the unused conductors on both ends of the motor cable.

Failure to follow these instructions will result in death or serious injury.

⚠ DANGER

ELECTRIC SHOCK CAUSED BY HIGH LEAKAGE (TOUCH) VOLTAGE

- Attach the terminal covers on the extremities of the *Bus Bar Module combination*, page 110.
- Apply power to the device only if the terminal covers have been attached to the extremities of the Bus Bar Module combination.

Failure to follow these instructions will result in death or serious injury.

⚠ DANGER

ELECTRIC SHOCK CAUSED BY HIGH LEAKAGE (TOUCH) VOLTAGE

- Before working on the product, make sure that it is de-energized.
- After disconnection, do not touch connector CN6 mains connection on the Lexium 62 Power Supply module as it still carries hazardous voltages for approximately one second.
- Only operate the Lexium 62 components in a control cabinet that cannot be opened without the help of tools.

Failure to follow these instructions will result in death or serious injury.

Assembly and Handling

This product has a leakage current greater than 3.5 mA. If the protective ground connection is interrupted, a hazardous touch current may flow if the housing is touched.

⚠ DANGER

INSUFFICIENT GROUNDING

- Use a protective ground copper conductor with at least 10 mm² (AWG 6) or two protective ground copper conductors with the same or larger cross section of the conductors supplying the power terminals.
- Verify compliance with all local and national electrical code requirements as well as all other applicable regulations with respect to grounding of all equipment.

Failure to follow these instructions will result in death or serious injury.

⚠ WARNING**CRUSHING, SHEARING, CUTTING AND HITTING DURING HANDLING**

- Observe the general construction and safety regulations for handling and assembly.
- Use appropriate mounting and transport equipment and use appropriate tools.
- Prevent clamping and crushing by taking appropriate precautions.
- Cover edges and angles to protect against cutting damage.
- Wear appropriate protective clothing (for example, protective goggles, protective boots, protective gloves).

Failure to follow these instructions can result in death, serious injury, or equipment damage.

Hot Surfaces

The metal surfaces of the product may exceed 65 °C (149 °F) (for bare metal) during operation.

⚠ WARNING**HOT SURFACES**

- Avoid unprotected contact with hot surfaces.
- Do not allow flammable or heat-sensitive parts in the immediate vicinity of hot surfaces.
- Verify that the heat dissipation is sufficient by performing a test run under maximum load conditions.

Failure to follow these instructions can result in death, serious injury, or equipment damage.

Magnetic and Electromagnetic Fields

Conductors and motors can generate strong local electrical and magnetic fields. This can cause interference in sensitive devices.

⚠ WARNING**ELECTROMAGNETIC FIELDS**

- Keep persons with electronic medical implants, such as pacemakers, away from the motor and the conductors.
- Do not place electromagnetically sensitive devices in the vicinity of the motor or of the conductors.

Failure to follow these instructions can result in death, serious injury, or equipment damage.

Hazardous Movements

There can be different sources of hazardous movements:

- No, or incorrect, homing of the drive
- Wiring or cabling errors
- Errors in the application program
- Component errors
- Error in the measured value and signal transmitter

NOTE: Provide for personal safety by primary equipment monitoring or measures. Do not rely only on the internal monitoring of the drive components. Adapt the monitoring or other arrangements and measures to the specific conditions of the installation in accordance with a risk and error analysis.

⚠ DANGER

UNAVAILABLE OR INADEQUATE PROTECTION DEVICE(S)

- Prevent entry to a zone of operation with, for example, protective fencing, mesh guards, protective coverings, or light barriers.
- Dimension the protective devices properly and do not remove them.
- Do not make any modifications that can degrade, incapacitate, or in any way invalidate protection devices.
- Before accessing the drives or entering the zone of operation, bring the drives and the motors they control to a stop.
- Protect existing workstations and operating terminals against unauthorized operation.
- Position EMERGENCY STOP switches so that they are easily accessible and can be reached quickly.
- Validate the functionality of EMERGENCY STOP equipment before start-up and during maintenance periods.
- Prevent unintentional start-up by disconnecting the power connection of the drive using the EMERGENCY STOP circuit or using an appropriate lock-out tag-out sequence.
- Validate the system and installation before the initial start-up.
- Avoid operating high-frequency, remote control, and radio devices close to the system electronics and their feed lines, and perform, if necessary, an EMC validation of the system.

Failure to follow these instructions will result in death or serious injury.

Drive systems may perform unanticipated movements because of incorrect wiring, incorrect settings, incorrect data or other errors.

⚠ WARNING

UNINTENDED MOVEMENT OR MACHINE OPERATION

- Carefully install the wiring in accordance with the EMC requirements.
- Do not operate the product with undetermined settings and data.
- Perform comprehensive commissioning tests that include verification of configuration settings and data that determine position and movement.

Failure to follow these instructions can result in death, serious injury, or equipment damage.

PELV Circuits

All signal and control voltages must be designed as PELV (Protective Extra Low Voltage) circuits. In particular, this implies protective measures against direct and indirect contact with hazardous voltage by:

- Ensuring that the voltage with respect to PE (Protective earth ground) remains below 30 Vdc.
- Ensuring separation between PELV circuits and other circuits implemented in the cabinet.

Connect GND / 0 V to PE at least at one point in the control cabinet.

Separate high and low voltage wiring and respect the standard IEC 61800-5-1, Adjustable speed electrical power drive systems - safety requirements.

⚠ DANGER

ELECTRIC SHOCK DUE TO INADEQUATE PROTECTIVE SEPARATION

Only connect devices, electrical components, or lines to the signal voltage connectors of these products that feature a sufficient, protective separation from the connected circuits in accordance with the standards (IEC 61800-5-1: Adjustable speed electrical power drive systems - safety requirements).

Failure to follow these instructions will result in death or serious injury.

Intended Use

Installation

Install and operate this equipment in a control cabinet (enclosure) appropriately rated for its intended environment and secured by a keyed or tooled locking mechanism.

Provide for Protective Measures

Before installing the device, provide for appropriate protective devices in compliance with local and national standards. Do not commission components without appropriate protective devices. After installation, commissioning, or repair, test the protective devices used.

Perform a risk evaluation concerning the specific use before operating the product and take appropriate safety measures.

▲ WARNING
UNINTENDED EQUIPMENT OPERATION
Ensure that a risk assessment is conducted and respected according to EN/ISO 12100 during the design of your machine.
Failure to follow these instructions can result in death, serious injury, or equipment damage.

If circumstances occur that affect the safety or cause changes to the operating behavior of the Lexium 62 components, then immediately shut down the Lexium 62 components and contact your Schneider Electric representative.

Use Original Equipment Only

Use only the accessories and mounting parts specified in the documentation and no third-party devices or components that have not been expressly approved by Schneider Electric.

There are no user-serviceable parts in the Lexium 62 Drive System. Do not attempt to modify the Lexium 62 Drive System in any way. Refer to Schneider Electric for all repairs and replacements.

▲ WARNING
UNINTENDED EQUIPMENT OPERATION
<ul style="list-style-type: none">• Only use software and hardware components approved by Schneider Electric for use with this equipment.• Do not attempt to service this equipment outside of authorized Schneider Electric service centers.• Update your application program every time you change the physical hardware configuration.
Failure to follow these instructions can result in death, serious injury, or equipment damage.

Environment Restrictions

The components must not be used in the following environments:

- In hazardous (explosive) atmospheres
- In mobile, movable, or floating systems
- In life support systems
- In domestic appliances
- Underground

This equipment has been designed to operate outside of any hazardous location. Only install this equipment in zones known to be free of a hazardous atmosphere.

⚠ DANGER

POTENTIAL FOR EXPLOSION

Install and use this equipment in non-hazardous locations only.

Failure to follow these instructions will result in death or serious injury.

Qualification of Personnel

Target Audience for This Manual

Electrical equipment must be installed, operated, serviced, and maintained only by qualified personnel. No responsibility is assumed by Schneider Electric for any consequences arising out of the use of this material.

Qualified Person

A qualified person is one who has skills and knowledge related to the construction and operation of electrical equipment and the installation, and has received safety training to recognize and avoid the hazards involved.

The qualified personnel must be able to detect possible hazards that may arise from parameterization, changing parameter values and generally from mechanical, electrical, or electronic equipment. The qualified personnel must be familiar with the standards, provisions, and regulations for the prevention of industrial accidents, which they must observe when working on the drive system.

Designated Safety Functions

Qualified personnel that work with designated safety functions must be trained according to the complexity of the machines and the requirements of the ISO 13849-1. The training has to include the production process and the relation between the designated safety function and the machine.

Qualification guidelines are available in the following publication: *Safety, Competency and Commitment: Competency Guidelines for Safety-Related System Practitioners*. IEEE Publications, ISBN 0 85296 787 X, 1999.

System Overview

System Overview

System Overview

The control system consists of several components, depending on its application.

PacDrive 3 system overview

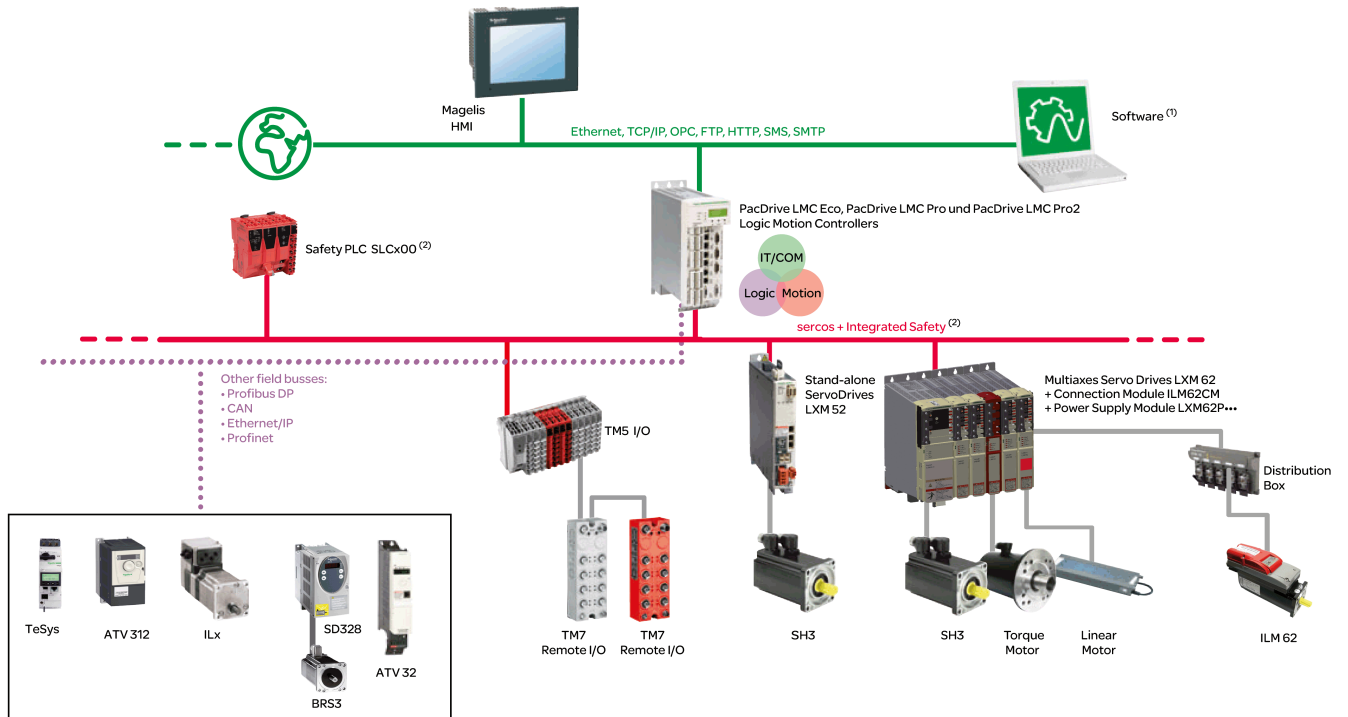

1 EcoStruxure Machine Expert Software

2 Safety Logic Controller according to IEC 61508 and ISO 13849

Logic Motion Controller

Overview

Product	Description
	<p>The Logic Motion Controller (LMC), with a VxWorks real-time operating system, centrally implements the Logic Controller and motion functions. The Logic Motion Controller synchronizes, coordinates, and creates the motion functions of a machine for a maximum of:</p> <ul style="list-style-type: none">• 0 Sercos servo drives for the controller LMC100• 4 Sercos servo drives for the controller LMC101• 6 Sercos servo drives for the controller LMC106• 8 Sercos servo drives for the controller LMC201• 12 Sercos servo drives for the controller LMC212• 16 Sercos servo drives for the controller LMC216• 8 Sercos servo drives for the controller LMC300• 16 Sercos servo drives for the controller LMC400• 16 Sercos servo drives for the controller LMC402• 99 Sercos servo drives for the controller LMC600• 130 Sercos servo drives for the controller LMC802• 130 Sercos servo drives for the controller LMC902

Lexium 62 Power Supply

Overview

Product	Description
	<p>The central Lexium 62 Power Supply, using a common DC bus, supplies the connected Lexium 62 servo drive(s) with the required power.</p> <p>For further information, refer to:</p> <ul style="list-style-type: none"> • <i>Installation and Maintenance</i>, page 102 • <i>Indicators of the Lexium 62 Power Supply</i>, page 140 • <i>Electrical Connections for the Lexium 62 Power Supply</i>, page 147 • <i>Mechanical and Electrical Data for the Lexium 62 Power Supply</i>, page 171

References

Product	Reference
Power supply	LXM62PD20A11000 LXM62PD84A11000

Type Code

Item	Meaning								
Product family	LXM = Lexium								
Size	62 = Lexium 62								
Type	P = Power Module								
Peak current	D84 = 84 A D20 = 20 A								
Variants	A = Power Supply Module								
Options	1 = 1 or 3 Phases x 208...480 Vac								
Hardware release	1								
Internal	0 = Serial production								
Customer	00 = Standard								
Type code (example)	LXM	62	P	D84	A	1	1	0	00

Technical Nameplate

The technical nameplate is located laterally on the housing.

Label	Meaning
LXM62PDxxxxxxx	Commercial reference
Input ac/dc	Input voltage and/or input current (rated- and/or peak value per input)
Output dc	Output voltage and output current (rated and/or peak value per output)
Control Voltage	Input control voltage and Input control current
Multiple rated equipment, see instruction manual	The different wiring arrangements with corresponding different capabilities are available in the instruction manual.
Short Circuit Current Rating	Maximum level of short-circuit current
IP20	Ingress protection rating
Country of origin	Manufacturing country
Schneider Electric	Manufacturer
Symbols	This field displays the symbols of declarations and certifications

Logistic Nameplate

The technical nameplate is located on top of the housing.

Label	Meaning
RS:01	Hardware revision
LXM62PDxxxxxxx	Commercial reference
dd.mm.yyyy	Date of manufacture
2528044067	Serial number (also available in the barcode)
Power Supply	Product range

Lexium 62 Servo Drive

Overview

The servo drive system Lexium 62 is used for the operation of servo drives in a multi-axis group.

The power electronic components of the Lexium 62 are fitted inside the control cabinet.

Product	Description
	<p>The Lexium 62 Servo Drives, provide the necessary phase currents for the position control of the connected servo motors. The Lexium 62 Servo Drives includes Lexium 62 Single Drives and/or Lexium 62 Double Drives.</p> <p>In addition, Lexium 62 Servo Drives are suitable for applications involving asynchronous motors.</p> <p>According to the different requirements in relation to the individual servo axes of the application, the Lexium 62 Servo Drives are available in different current classes.</p> <p>The Lexium 62 helps to simplify the wiring of the drives. This also applies to the cable connection of the enclosed drives to the field. The connectors that can be connected from the outside (power input, DC bus, 24 Vdc supply, Sercos, motor, encoder, I/O modules, I/O supply, Ready, and Inverter Enable) are designed so that a fast, simple configuration on the drive can be realized.</p> <p>For further information, refer to:</p> <ul style="list-style-type: none"> • <i>Installation and Maintenance</i>, page 102 • <i>Indicators of the Lexium 62 Servo Drive</i>, page 143 • Electrical Connections: <ul style="list-style-type: none"> <i>for the Lexium 62 Variants C, D, E, F</i>, page 151 <i>for the Lexium 62 Variants G</i>, page 152 <i>for the Single Drive LXM62DC13C21000/LXM62DC13E21000</i>, page 153 • Mechanical and Electrical Data: <ul style="list-style-type: none"> <i>for the Lexium 62 Single Drives</i>, page 173 <i>for the Lexium 62 Double Drives</i>, page 178

Lexium 62 Single Drives - References

Product	Variant	Reference
Single servo drives	C	LXM62DU60C LXM62DD15C LXM62DD27C LXM62DD45C LXM62DC13C
Single servo drives - Advanced	G	LXM62DU60G LXM62DD15G LXM62DD27G LXM62DD45G LXM62DC13G
Single servo drives with embedded safety	E	LXM62DU60E LXM62DD15E LXM62DD27E LXM62DD45E LXM62DC13E

Lexium 62 Double Drives - References

Product	Variant	Reference
Double servo drives	D	LXM62DU60D LXM62DD15D LXM62DD27D
Double servo drives with embedded safety	F	LXM62DU60F LXM62DD15F LXM62DD27F

Type Code

Item	Meaning								
Product family	LXM = Lexium								
Size		62 = Lexium 62							
Type		D = Drive Module							
Peak current		U60 = 6 A D15 = 15 A D27 = 27 A D45 = 45 A C13 = 130 A							
Variants		C = Single Drive HW-STO SIL 3 Ple D = Double Drive HW-STO SIL 3 Ple E = Single Drive Embedded Safety SIL 3 Ple F = Double Drive Embedded Safety SIL 3 Ple G = Single Drive Advanced ⁽¹⁾ SIL 3 Ple							
Options		2 = 250...700 Vdc							
Internal		1							
Connection version		0 = Standard product							
Customer		00 = Standard							
Type code (example)	LXM	62	D	U60	C	2	1	0	00
(1) Advanced type supports the functions machine encoder input and incremental encoder output.									

Technical Nameplate

The technical nameplate is located laterally on the housing.

Label	Description
LXM62xxxxxxxxxx	Commercial reference
Schneider Electric	Manufacturer
Input ac/dc	Input voltage and/or input current (rated and/or peak value per input)
Output ac/dc	Output voltage and output current (rated and/or peak value per output)
Control Voltage	Control Voltage
Motor Overload Protection	Class of motor overload protection
IP20	Ingress protection rating
Short Circuit Current Rating	Maximum level of short-circuit current
Certifications	

Logistic Nameplate

The logistic nameplate is located on top of the housing.

Label	Description
LXM62xxxxxxxxxx	Commercial reference
Code	Serial Number as barcode
2528128802	Serial number
#000000	Customer number (for customer versions only)
10.11.2015	Date of manufacture (DOM)
RS 01	Hardware revision

Lexium 62 DC Link Terminal and Lexium 62 DC Link Support Module



Overview

The wiring with Lexium 62 DC Link Terminal allows the connection of several rows of Lexium 62 drives.

The rows of devices may have different locations:

- Location within the same control cabinet, for example one row above the other row, or
- Location in separate control cabinets.

Wiring with Lexium 62 DC Link Terminal requires the following components:

Product	Description
	<p>The Lexium 62 DC Link Terminal LXM62LT00A01000 is used to connect a cable to the bus bar module of the Lexium 62 devices.</p> <p>The Lexium 62 DC Link Terminal can be mounted on the right hand and on the left-hand side of the bus bar module of the Lexium 62 devices.</p> <p>The connectors are attached to Lexium 62 devices during manufacturing of your machine, during the installation at the end use facility, or during maintenance. Usually, direct, uninterrupted wiring between the Lexium 62 devices is applied. If you intend to use inter-connectors, for example, between control cabinets, they must be of a design such that they cannot be disconnected during operation.</p> <p>A strain relief for cable support is enclosed to the Lexium 62 DC Link Terminal.</p> <p>For further information, refer to:</p> <ul style="list-style-type: none"> • <i>Installation and Maintenance</i>, page 102 • <i>Electrical Connections for the Lexium 62 DC Link Terminal</i>, page 166 • <i>Mechanical and Electrical Data for the Lexium 62 DC Link Terminal</i>, page 182
	<p>The Lexium 62 DC Link Support Module LXM62LS18A01000 can be integrated into Lexium 62 Drive System.</p> <p>The Lexium 62 DC Link Support Module is a passive module with capacitors.</p> <p>For further information, refer to:</p> <ul style="list-style-type: none"> • <i>Installation and Maintenance</i>, page 102 • <i>Electrical Connections for the Lexium 62 DC Link Support Module</i>, page 165 • <i>Mechanical and Electrical Data for the Lexium 62 DC Link Support Module</i>, page 184

For further information, refer to the *LXM62LT00A01000 Lexium 62 DC Link Terminal, Instruction Sheet*, page 8.

References

Product	Reference
Lexium 62 DC Link Terminal	LXM62LT00A01000
Lexium 62 DC Link Support Module	LXM62LS18A01000

Type Code

Item	Meaning								
Product family	LXM = Lexium								
Size	62 = Lexium 62								
Type	LS = DC Link Support Module LT = DC Link Terminal								
Values	Value LXM62LSxxx 18 = 1.76 mF (mFarad*10) Value LXM62LTxxx 00 = None								
Variants	A								
Options	0								
Hardware Release	1								
Internal	0								
Customer	00 = Standard								
Type code (example)	LXM	62	LS	18	A	0	1	0	00

Technical Nameplate

The technical nameplate is located laterally on the housing.

Label	Description
LXM62xxxxxxxxxx	Commercial reference
Schneider Electric	Manufacturer
Input a.c./d.c.	Input voltage and/or input current (rated and/or peak value per input)
Output a.c./d.c.	Output voltage and output current (rated and/or peak value per output)
Control Voltage	Control Voltage
Motor Overload Protection	Class of motor overload protection
IP20	Ingress protection rating
Short Circuit Current Rating	Maximum level of short-circuit current
Certifications	

Logistic Nameplate

The logistic nameplate is located on top of the housing.

Label	Description
LXM62xxxxxxxxxx	Commercial reference
Code	Serial Number as barcode
2528128802	Serial number
#000000	Customer number (for customer versions only)
10.11.2015	Date of manufacture (DOM)
RS 01	Hardware revision

QR Code - Description

QR Code



The QR-Code is on the front flap. When scanning the code, the following information is provided:

- Commercial reference of the drive
- Serial number (SN: xxxxxxxxxx)
- Date of manufacture (DOM: dd.mm.yyyy)
- Hardware revision (for example RS: 01)

SH3 Servo Motor

Overview

Product	Description
	<p>The SH3 motors are low-inertia AC synchronous servo motors designed for highly dynamic positioning tasks.</p> <p>A drive system consists of the servo motor and the drive. Maximum performance requires the motor and drive to be adapted to each other.</p>

High Dynamic AC Servo Motors

Because of the low inertia and a high overload capability, the motor SH3 fulfills many requirements concerning the accuracy, dynamics, and efficiency.

The motors SH3 have the following characteristics:

- Overload protection by integrated temperature sensor (external evaluation required)
- Low moment of inertia
- High power density
- Excellent dynamics
- High overload capability
- Broad torque range
- Special winding for low phase currents
- Motor connection via circular connectors
- Easy commissioning via electronic nameplate in SinCos encoder
- Low maintenance

Options and Accessories

The motors are available with various options such as:

- Various encoder systems
- Holding brake
- Various shaft versions
- Various degrees of protection
- Various lengths
- Various sizes
- Various connection versions

For further information, refer to the *SH3 Servo Motor - User Guide*, page 8.

MH3 Servo Motor

Overview

Product	Description
	<p>The MH3 motors are AC synchronous servo motors with a high power density. A drive system consists of the AC synchronous servo motor and the appropriate drive. Maximum performance requires the motor and drive to be adapted to each other.</p>

Dynamic AC Servo Motors

With four flange sizes and three different lengths for each flange size, they are suitable for many applications, covering a continuous stall range from 1.4 to 65 Nm (1.0 to 47.9 lbf ft) for speeds up to 6000 rpm. The MH3 servo motors have a medium motor inertia, which means they are suitable for high-load applications.

The AC synchronous servo motors excel with:

- High power density: the use of the latest magnetic materials and an optimized design result in motors with a shorter length at a comparable torque.
- High peak torque: the peak torque can be up to four times the continuous stall torque.

Options and Accessories

The motors are available with various options such as:

- Holding brake
- Various shaft versions
- Various lengths
- Various sizes

For further information, refer to the *MH3 Servo Motor - Motor Manual*, page 8.

BMP Synchronous Motor

Overview

Product	Description
	The BMP motors are AC synchronous motors with a high power density. A drive system consists of the AC synchronous servo motor and the appropriate drive. Maximum performance requires the motor and drive to be adapted to each other.

Characteristics

The AC synchronous motors excel with:

- High power density: the use of the latest magnetic materials and an optimized design result in motors with a shorter length at a comparable torque.
- High energy efficiency: due to optimized stator and rotor design with permanent magnets. Since these motors have a smaller size and operate without forced cooling, the surface temperature may be higher than that of an asynchronous motor.

Options and Accessories

The motors are available with various options such as:

- Various lengths
- Various sizes

For further information, refer to the *BMP Synchronous Motor - Motor Manual*, page 8.

Combinations of Lexium 62 Drives and BMP Motors

Lexium 62 drive			BMP motor		
Reference	In	I _{max}	Reference	In	I _{max}
DC bus voltage: 283...339 VDC (U _{mains} : 1~ 200...240 VAC)					
LXM62DU06	2	6	BMP0701R	1.45	5
	2	6	BMP0702R	2.08	5.6
	2	6	BMP1001R	2.7	7.2
LXM62DD15	5	15	BMP1002R	5.72	12
	5	15	BMP1401F	4.42	10.4
	5	15	BMP1401F	4.42	12
LXM62DD27	9	27	BMP1401R	7.74	16.5
	9	27	BMP1402F	9.24	16.5
DC bus voltage: 693...831 VDC (U _{mains} : 3~ 400...480 VAC)					
LXM62DU06	2	6	BMP0701F	0.8	2.3
	2	6	BMP0702F	1.16	2.9
	2	6	BMP1001F	1.4	4.5
	2	6	BMP1401C	2.29	6.2
LXM62DD15	5	15	BMP1002F	3.05	6.2
	5	15	BMP1401F	4.12	8.3
	5	15	BMP1401C	4.83	8.3
LXM62DD27	9	27	BMP1401F	6.45	14.3

For further information, refer to the *BMP Synchronous Motor - Motor Manual*, page 8.

SinCos Encoder

Overview

A SinCos encoder may be used as a machine encoder. The encoder must provide an electronic typeplate via the Hiperface interface for commissioning.

NOTE: The encoder must have 1 kB of free memory available for the electronic typeplate.

The following table provides the encoder characteristics:

Characteristic	Value
Signal shape	Sinusoidal
Supply voltage	7...12 Vdc
Maximum supply current	150 mA
SinCos periods per second	Maximum 100.000 SinCos periods / second = maximum 100 kHz
Resolution per revolution	Up to 1024 SinCos periods / revolution
Cable length	Up to 75 m
Cable shield	Required, connected to encoder and drive
Differential output voltage at drive input	0.8 Vpp...1.1 Vpp
Differential output offset	2.5 Vdc

For further information, refer to the electrical specifications of encoder interface:

- *Mechanical and Electrical Data for Single Drives*, page 173
- *Mechanical and Electrical Data for Double Drives*, page 178

Engineering

Electromagnetic Compatibility, EMC

Electromagnetic Disturbances of Signals and Devices

This product meets the EMC requirements according to the standard IEC 61800-3 if the measures described in this manual are implemented during installation.

Signal interference can cause unexpected responses of the drive and of other equipment in the vicinity of the drive.

⚠ WARNING

SIGNAL AND EQUIPMENT INTERFERENCE

- Only operate the drive with the specified external mains filter.
- Install the wiring in accordance with the EMC requirements described in the present document.
- Verify compliance with the EMC requirements described in the present document.
- Verify compliance with all EMC regulations and requirements applicable in the country in which the product is to be operated and with all EMC regulations and requirements applicable at the installation site.

Failure to follow these instructions can result in death, serious injury, or equipment damage.

⚠ WARNING

ELECTROMAGNETIC DISTURBANCES OF SIGNALS AND DEVICES

Use proper EMC shielding techniques to help prevent unintended device operation in accordance with the standard IEC 61800-3.

Failure to follow these instructions can result in death, serious injury, or equipment damage.

These types of devices are not intended to be used on a low-voltage public network which supplies domestic premises. Radio frequency interference is expected if used in such a network.

⚠ WARNING

RADIO INTERFERENCE

Do not use these products in domestic electrical networks.

Failure to follow these instructions can result in death, serious injury, or equipment damage.

Layout Control Cabinet (Enclosure)

The prerequisite for compliance with the specified limit values is an EMC compatible layout. Depending on the application, the following measures can improve the EMC-dependent values:

EMC measures	Objective
The devices must be mounted on a conductive surface. Use galvanized or chromium-plated sub plates, bond metallic parts across large surface areas, remove paint layer from contact surfaces.	Good conductivity by surface area contact.
Ground control cabinet (enclosure), door, and sub plates by using grounding strips or grounding cables with a cross-section of 10 mm ² (AWG 6).	Reduce emission.
Supplement switch devices such as contactors, relays, or magnetic valves with interference suppression combinations or spark suppressor elements (for example, diodes, varistors, RC elements).	Reduces mutual interference.
Fit power and control components separately.	Reduces mutual interference.

Shielded Cables

EMC measures	Objective
Connect large surface areas of cable shields, use cable clamps and ground straps.	Reduce emission.
Ground shields of digital signal wires at both ends by connecting them to a large surface area or via conductive connector housings.	Reduce interference action on signal cables, reduce emissions.
Ground shield of analog signal cables directly on the device (signal input), insulate the shield at the other cable end or ground the same through a capacitor, such as 10 nF.	Reduce grounding loops by low frequency interferences.

Cable Installation

EMC measures	Objective
Do not route fieldbus cables and signal wires in a single cable duct together with lines with DC and AC voltages of more than 60 V. (Fieldbus cables, signal lines, and analog lines may be in the same cable duct) Recommendation: Use separate cable ducts at least 20 cm (7.84 in) apart.	Reduces mutual interference.
Keep cables as short as possible. Do not install unnecessary cable loops, use short cables from the central grounding point in the control cabinet to the external ground connection.	Reduces capacitive and inductive interference.
Use equipotential bonding conductors (stranded wire of equal potential at all grounding locations connected to an equipotential grounding plane) in the following cases: wide-area installations, different voltage supplies, and installation across several buildings.	Reduces current in the cable shield, reduces emissions.
Use stranded wire potential equalization conductor.	Discharging of high frequency interference currents.
If motor and machine are not conductively connected, for example by an insulated flange or a connection without surface contact, you must ground the motor with a ground strap or a ground wire. The conductor cross section must be at least 10 mm ² (AWG 6).	Reduces emissions, increases immunity.
Use twisted pair for 24 Vdc signals.	Reduce interference action on signal cables, reduce emissions.

Power Supply

EMC measures	Objective
Operate product on mains with grounded neutral point.	Enables effectiveness of mains filter.
Use surge arrester if there is a risk of overvoltage.	Reduces the risk of damage caused by overvoltage.

Motor and Encoder Cables

From an EMC perspective, motor supply cables and encoder cables are important. Only use pre-configured cables, or cables with the prescribed properties, and comply with the following EMC measures.

EMC measures	Objective
Do not install switching elements in motor cables or encoder cables.	Reduces interference.
Route motor cable with a distance of at least 20 cm (7.84 in) to the signal cables or insert shield plates between the motor supply cable and the signal cable.	Reduces mutual interference.
For wiring that approaches the maximum cable distance specification (75 m/ 246.06 ft.), use equipotential bonding connection cables.	Reduce current on cable shield.
Route motor supply cables and encoder cables without any separation point ⁽¹⁾ .	Reduces emission.
(1) If a cable must be cut through for installation purposes, the cables must be connected at the point of separation by using screen connections and metal housing.	

Additional Measures for Improving the EMC

Depending on the respective application, the following measures may lead to an EMC compatible layout:

EMC measures	Objective
Upstream connection of mains line reactor (choke)	Reduction of the harmonic network oscillations, extension of the service life of the product.
Upstream connection of external mains filters	Improvement of the EMC limit values.
Special EMC-appropriate layout, for example, within an enclosed control cabinet complete with 15 dB attenuation of the interferences emitted	Improvement of the EMC limit values.

Control Cabinet Planning

Degree of Protection (IP)

Overview

Install components such that an Ingress Protection (IPxx) corresponding to the actual operational environment is set up.

For further information on the IP rating of the component, refer to *Ambient Conditions*, page 169.

The following ambient conditions may damage the components:

- Oil
- Moisture
- Electromagnetic interference
- Ambient temperature
- Metal dust deposits

▲ WARNING

UNINTENDED EQUIPMENT OPERATION

- Observe and conform to ambient temperatures, storage temperatures and transport temperatures of the individual components as specified in the operating manuals of the components.
- Prevent the formation of moisture during the operation, storage and transport of individual components.
- Conform to the vibration and shock requirements specified in the operating manuals for the components when operating, storing and transporting system components.

Failure to follow these instructions can result in death, serious injury, or equipment damage.

Mechanical and Climatic Environmental Conditions in the Control Cabinet

Overview

Step	Action
1	Observe the climatic and mechanical ambient conditions. For further information on the general climatic and mechanical environmental conditions according to IEC 60721, refer to <i>Ambient Conditions</i> , page 169.
2	Verify the technical data of the device whether the permitted deviations (for example, higher shock load or higher temperature) are specified.

Using Cooling Units

Installing a Cooling Unit

How to proceed when installing a cooling unit:

Step	Action
1	Position the cooling units so that no condensate drips out of the cooling unit onto electronic components or is sprayed by the cooling air flow.
2	Provide specially designed control cabinets for cooling units on the top of the control cabinet.
3	Design the control cabinet so that the cooling unit fan cannot spray any accumulated condensate onto the electronic components when it restarts after a pause.
4	When using cooling units, use only well-sealed control cabinets so that warm, humid outside air, which causes condensation, does not enter the cabinet.
5	When operating control cabinets with open doors during commissioning or maintenance, ensure that the electronic components are at no time cooler than the air in the control cabinet after the doors are shut, in order to avoid any condensation.
6	Continue to operate the cooling unit even when the system is switched off, so that the temperature of the air in the control cabinet and the air in the electronic components remains the same.
7	Set cooling unit to a fixed temperature of 40 °C or lower (104 °F).
8	For cooling units with temperature monitoring, set the temperature limit to 40 °C (104 °F) so that the internal temperature of the control cabinet does not fall below the external air temperature.

⚠ WARNING

UNINTENDED EQUIPMENT OPERATION

Follow the installation instructions such that the condensation from the cooling unit can not enter electrical equipment.

Failure to follow these instructions can result in death, serious injury, or equipment damage.

Installing a cooling unit

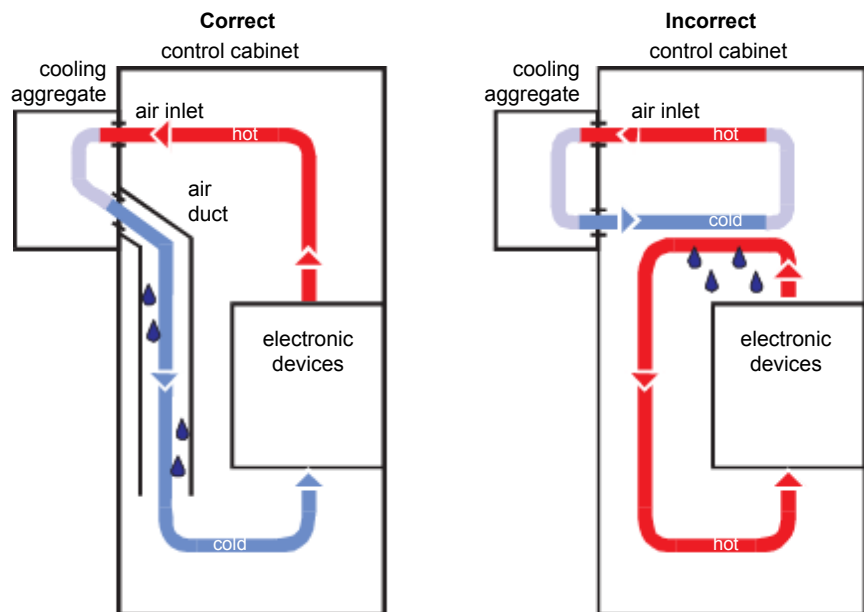

Information about Wiring

General Information about Wiring

Overview

Use only Schneider Electric approved devices in your application, and especially Schneider Electric pre-fabricated cables, wherever and whenever possible.

For further information, refer to *Cable Characteristics*, page 41.

Use an appropriate torque indication or screwdriver for tightening connections.

For further information on the tightening torques and cable cross-sections, refer to *Electrical Power Connections*, page 147.

Observe and implement the following points when wiring:

1. Observe the minimum cross-sections of the cables necessary for the load carrying capacity of the equipment being connected.
2. Verify the integrity of cable shields to ensure continuity to ground.
3. Ensure that there is a proper, equipotential connection to ground for all interconnected equipment.
4. Ensure connection of the motors to the machine ground.
5. Eliminate any ground loops.
6. Do not disconnect cable connection terminals when under power.
7. Ensure that all ground connections have sufficient surface area continuity.
8. Do not interchange motor phases.
9. Do not interchange encoder connections.
10. Do not interchange the emergency stop circuits. This has to be observed especially when two different safety-related circuits are used for axis A and axis B of the Lexium 62 Double Drive.

If, for example, two parallel conductors are shown as coming from one point, you may not run just one conductor and then branch it off at a later point. If it is wired this way, induction loops (interference emitters and antennas) as well as interfering potential shifts may occur.

⚠ DANGER

INCORRECT OR UNAVAILABLE GROUNDING

Remove paint across a large surface at the installation points before installing the devices (bare metal connection).

Failure to follow these instructions will result in death or serious injury.

Cable Characteristics

Overview

The following specifications apply to the motor and encoder cables:

Cable	Property	Unit
Motor cables	AWM Style	–
Encoder cables	AWM Style	–
Motor supply cable voltage isolation	Conducting wire: 1000 (UL and CSA) Signal wire brake: 600 (UL and CSA)	[Vac]
Encoder cable isolation voltage	300 (UL and CSA)	[Vac]
Temperature range	-40...+90 / -40...+194 (fixed routing) -20...+80 / -4...+176 (mobile)	[°C] / [°F]
Bending radius	5 x diameter (fixed routing) 12 x diameter (mobile)	–
Corrosion resistance of the cable insulation	Oil resistant PUR, hydrogen peroxide	–
Sheath	Halogen-free	–
Shield	Braided shield	–
Covering of the braided shield	≥85	[%]

Motor and encoder cables are drag chain capable.

Cable characteristics of the Sercos cable (see the Schneider Electric catalog for the various cables available):

Property	Value
Voltage isolation (jacket)	300 Vdc
Temperature range	-20...+60 °C / -4...+140 °F
Cable diameter	5.8 ± 0.2 mm (0.23 ± 0.008 in.)
Bending radius	8 x diameter (fixed routing)
Sheath	PVC, flame-retardant
Cable type and shielding	CAT6 with S/FTP (Sercos III)

Configuring and Coding the Cables

Overview

For configuring and coding the cables, use the appropriate connector kit supplied with the device.

Accessory Kit Power Supply

Accessory part	Number	Connection designation
Connector ready	1	CN4
Connector 24 V-In	1	CN5
Connector AC-In	1	CN6
Connector DC bus	1	CN7
Sercos cable 130 mm (5.11 in)	1	–

Accessory Kit Single Drive

Accessory part	Drive reference	Number	Connection designation
Connector digital I/Os		1	CN4
Connector 24 V I/O supply		1	CN5
Connector Inverter Enable		1	CN6
Connector Inverter Enable 2-channel		1	CN11
Coding tab PC5 for coding the motor connector		1	–
Coding tab FMC for coding the motor connector		1	–
Sercos cable 90 mm (3.54 in)	LXM62DD LXM62DU	1	–
Sercos cable 115 mm (4.52 in)	LXM62DC	1	–
Sercos cable 130 mm (5.11 in)		1	–
Sercos cable 150 mm (5.90 in)		1	–
Shield plate		1	–
Motor connector	LXM62DD LXM62DU	1	CN8
Motor connector consisting of two separate motor connectors:	LXM62DC		
Motor temperature and holding brake		1	CN8_1
Motor phases		1	CN8_2

Accessory Kit Double Drive

Accessory part	Number	Connection designation
Connector digital I/Os	2	CN4
Connector 24 V I/O supply	1	CN5
Connector Inverter Enable	1	CN6
Connector Inverter Enable 2-channel	1	CN11
Motor connectors	2	CN8 / CN10
Coding tab PC5 for coding the motor connector	2	–
Coding tab FMC for coding the motor connector	2	–
Sercos cable 90 mm (3.54 in)	1	–
Shield plate	1	–

ESD Protection Measures

General

Observe the following instructions to help avoid damages due to electrostatic discharge:

NOTICE

ELECTROSTATIC DISCHARGE

- Do not touch any of the electrical connections or components.
- Prevent electrostatic charges, for example, by wearing appropriate clothing.
- If you must touch circuit boards, do so only on the edges.
- Remove existing static charge by touching a grounded, metallic surface.

Failure to follow these instructions can result in equipment damage.

Conditions for UL / CSA Compliant Use

General

If you use the Lexium 62 Drive System in accordance with UL or CSA standards, you must additionally, aside from the installation requirements stated in the present document, meet the following conditions:

- Install the “open type equipment” Lexium 62 Drive System at a maximum surrounding air temperature of 40 °C / 55 °C with derating.
- Connect the Lexium 62 Drive System only to a grounded wye source (maximum 480Y/277V).
- Install the Lexium 62 Drive System only in a Pollution Degree 2 environment.
- According to UL 61800-5-1 rules, direct measurement of motor over-temperature is required. Therefore, connect the temperature sensor of the motor to connection **CN8** or **CN10**, depending on the drive reference, whether it be a Single Drive whereas the connection is on **CN8**, or a Double Drive whereas the connections are on **CN8** and **CN10**; one sensor respectively on each connector. For further information, refer to *Electrical Connection - Lexium 62 Servo Drives*, page 162.
- To protect the Lexium 62 Power Supply, use a Class J fuse according to UL 248 with a maximum fuse rating of 50 A / 600 Vac, suitable for use on a circuit capable of delivering up to 50 kA rms symmetrical /480 Vac maximum when protected by Class J fuses sized at maximum 125% percent of the input current rating of the AC/DC converter.
- Use an isolating 24 Vdc rated (maximum 42.4 V peak) power supply for control circuits.

Integral solid-state short circuit protection does not provide branch circuit protection. Branch circuit protection must be provided in accordance with the National Electrical Code and any additional local codes, or the equivalent.

Short-Circuit Current Rating (SCCR)

Only connect the Lexium 62 Drive System to a mains supply network not exceeding the non-operational case of SCCR (Short Circuit Current Rating) from following table, or take appropriate measures according to UL 508 A SB4 in the supply (feeder) circuit of the control cabinet to limit the short circuit current to a value below the least SCCR of those devices you are using from the following table.

NOTE: The branch-circuit protective device is connected upstream of the Lexium 62 Drive System; that is to say upstream of the power supply modules LXM62P•••A1, which are used together with the drives.

NOTE: The opening of the branch-circuit protective device (fuses in the case of UL conformance, or any circuit breaker) may be an indication that an invalid condition has been interrupted. To reduce the risk of fire or electric shock, current-carrying parts and other components of the controller must be examined and replaced if damaged. If burnout of the current element of an overload relay occurs, the complete overload relay must be replaced. In any and all cases, determine the source of the opening of the branch-circuit protection before re-applying power to the system.

DANGER

FIRE, ELECTRIC SHOCK OR ARC FLASH

Examine and replace if necessary any current-carrying parts or other motor control components in the case of mains- or branch-circuit protection activation.

Failure to follow these instructions will result in death or serious injury.

Lexium 62 Drive System	References	SCCR, with line choke	SCCR, without line choke
Lexium 62 Power Supply	LXM62P	50 kA	5 kA
Lexium 62 Servo Drive	LXM62D	50 kA	5 kA
Lexium 62 DC Link Support Module	LXM62LS	50 kA	5 kA

According to CSA 22.2 No.14, only a short circuit current rating of 5 kA is permissible.

NOTE: Line reactors according to UL 508A (SB 4.2.1 Exception No. 1) are not required to have a short-circuit current rating (SCCR).

Notes on Wiring

- For the wiring of the Lexium 62 Power Supply and Lexium 62 Servo Drive (for LXM62DD and LXM62DU), use at least 60 °C (140 °F) copper conductors.
- For the wiring of the LXM62DC Lexium 62 Servo Drive, use 75 °C (167 °F) copper conductors.
- Choose the cross-section according to the load of the system and selected overload protection in your application.

Consider the applicable cross section for the terminal blocks according to following tables:

For Lexium 62 Power Supply

Connection	Torque [Nm] / [lbf in]	Connection cross section [mm ²] / [AWG] ⁽¹⁾
CN1	2.5 / 22	N/A
CN5	N/A	0.5...16 / 20...6
CN6	N/A	0.75...16 / 18...6
CN7	N/A	0.2...6 / 24...10
CN4	N/A	0.5...1.5 / 20...16

(1) To protect the Lexium 62 Power Supply, use a Class J fuse according to UL 248 with a maximum fuse rating of 50 A / 600 Vac.

For Lexium 62 Servo Drive

Connection	Drive references	Torque [Nm] / [lbf in]	Connection cross section [mm ²] / [AWG]
CN1	-	2.5 / 22	N/A
CN8 / CN10	LXM62DD LXM62DU	N/A	0.2...6 / 24...10
CN8_1	LXM62DC	N/A	0.2...1.5 / 24...16
CN8_2		N/A	4...6 / 12...10
CN5	-	N/A	0.2...1.5 / 24...16
CN4		N/A	0.2...1.5 / 24...16
CN6		N/A	0.2...1.5 / 24...16

- Verify whether the screws of the wiring bus (**CN1**) have been tightened with 2.5 Nm (22 lbf in).
- Only use motor cables approved by Schneider Electric that comply with the requirements of NFPA 79.
- Before using wiring with Lexium 62 DC Link Terminal, observe the *Cable selection guidelines for wiring with Lexium 62 DC link terminal*, page 63.

NOTE: The drive integrates an overload protection between the drive module and the motor.

DC Bus Coupling

When using the DC bus connection on **CN7** of the Lexium 62 Power Supply, ensure that the current is limited to 35 A via this connection with an appropriate fuse or circuit breaker.

Fusing the Mains Connection

General

This data is only valid for fusing the mains connection of each Lexium 62 Power Supply module:

- Protect the power supply against any short-circuit and overload using appropriate measures.
- Set the overload protection depending on the permanent current of the device:
 - Lexium 62 Power Supply (LXM62PD84A11000) maximum of 40 A (3-phase),
 - Lexium 62 Power Supply (LXM62PD20A11000) maximum of 10 A (3-phase).

NOTE: The opening of the branch-circuit protective device (fuses in the case of UL conformance, or any circuit breaker) may be an indication that an invalid condition has been interrupted. To reduce the risk of fire or electric shock, current-carrying parts and other components of the system should be examined and replaced if damaged. If burnout of the current element of an overload relay occurs, the complete overload relay must be replaced. In any and all cases, determine the source of the opening of the branch-circuit protection before re-applying power to the system.

⚠ DANGER

FIRE, ELECTRIC SHOCK OR ARC FLASH

Examine and replace if necessary any current-carrying parts or other motor control components in the case of mains- or branch-circuit protection activation.

Failure to follow these instructions will result in death or serious injury.

Suitable Combinations

Combine mains contactor and motor protection switch for protection of a Lexium 62 Power Supply as follows:

Mains current	DC bus current (with mains lines reactor)	Connection type	Protection Lexium 62 Power Supply (LXM62PD20A11000)	Protection Lexium 62 Power Supply (LXM62PD84A11000)
16 A	≤ 8 A	1-phase	Circuit breaker iC60N, characteristic C, 16 A	–
20 A	≤ 10 A	1-phase	Circuit breaker iC60N, characteristic C, 20 A	–
9.5 A	≤ 10 A	3-phase	TeSys Model U LUB12 with LUCA12BL	–
12 A	≤ 12.5 A	3-phase	–	TeSys Model U LUB12 with LUCA12BL
18 A	≤ 19 A	3-phase	–	TeSys Model U LUB32 with LUCA18BL
32 A	≤ 33.5 A	3-phase	–	TeSys Model U LUB32 with LUCA32BL
40 A	≤ 42 A	3-phase	–	Mains contactor LC1D40ABD motor protection switch GV3P40

Limit the external 24 Vdc supply to the Lexium 62 Power Supply module with adequate means to 50 A.

Mains Contactor

General

The Lexium 62 Power Supply requires a mains contactor in order to be able to remove power to the Lexium 62 components. This mains contactor is controlled by the Ready relay output. Here, the mains contactor may operate only if the Ready relay output contact is closed. The Ready chain may comprise additional switches which prevent the mains contactor from responding or cause the contactor to release although the Ready relay output contact is closed, such as may be the case in your functional safety architecture.

The selection of the mains contactor must be in accordance with the protection requirements of the mains line.

For further information, refer to *Fusing the Mains Connection*, page 48.

Mains Filter

General

The internal mains filtering system is effective when the sum of all motor cable lengths is 150 m or less. For applications whose sum of all motor cable lengths exceeds 150 m, an external mains filter is required to maintain the normative limit values.

EMC filter

Length of the motor cables	IEC 61800 class	Notes
<15...150 m (49...492 ft)	C3	–
> 150 m (492 ft)	C3	External EMC filter required

NOTE: For additional information on mains filtering, contact your Schneider Electric representative.

Mains Line Reactor (Choke)

Overview

A mains line reactor (choke) is required for the application. A mains line reactor is necessary to reduce the harmonics of the mains current. The mains line reactor must have at least 4% voltage drop at rated load.

Without UL /CSA Certification

Mains line reactor without UL /CSA certification:

- Schneider Electric: VW3SKLN016H003E for architectures up to 16 A single phase

With UL/CSA Certification

Mains line reactor with UL / CSA certification:

- Schneider Electric: VPM05D100000 for architectures up to 10 A
- Schneider Electric: VPM05D250000 for architectures up to 25 A
- Schneider Electric: VPM05D500000 for architectures up to 50 A
- Schneider Electric: VW3A4551 for architectures up to 4 A
- Schneider Electric: VW3A4552 for architectures up to 10 A
- Schneider Electric: VW3A4553 for architectures up to 16 A
- Schneider Electric: VW3A4554 for architectures up to 30 A
- Schneider Electric: VW3A4555 for architectures up to 60 A

A shielded version of the connection cables is not required.

NOTE: Verify that the rated current of the mains line reactor is above preset overload protection of the protective device.

Correlation Between Mains Current and DC Bus Current (3-Phase Operation)

The mains current is approximately the same as the DC bus current and corresponds to the current of the mains line reactor. For the design of the mains line reactor, use a dimensioning of the mains current of 100% to 110% of the DC bus current.

Connection of the Lexium 62 Power Supply

Overview

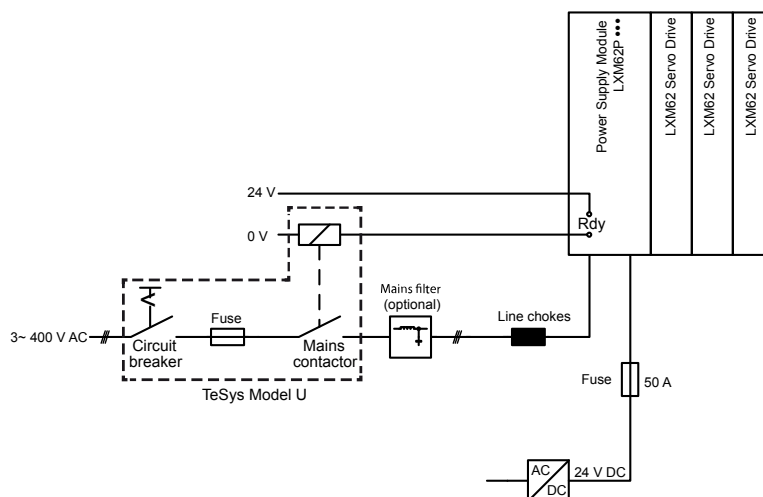

NOTE: The 24 Vdc supply input current must be limited to 50 A maximum, which can be realized by a 50 A fuse as shown above. In particular, a 50 A fuse is mandatory if a non-current limiting 24 Vdc power supply is used.

For further information, refer to *Fusing the Mains Connection*, page 48.

Parallel Connection of Several Lexium 62 Power Supplies (LXM62PD84A11000)

Overview

If DC bus currents are required that go beyond the rating of one Lexium 62 Power Supply, up to 3 Lexium 62 Power Supply modules of type LXM62PD84A11000 can be connected in parallel.

Using a parallel connection of several Lexium 62 Power Supplies (LXM62PD84A11000), the available DC bus current and thus the power can be increased.

The maximum DC Bus capacity which can be connected can also be increased by a parallel connection of Lexium 62 Power Supply devices. The overall DC Bus capacity which can be driven by a single Lexium 62 Power Supply (including the internal DC Bus capacity of the Lexium 62 Power Supply) is 12.5 mF. The additional capacity for a second and each further parallel connected LXM62PD84A11000 amount to 9.4 mF each.

Parallel connection of up to 3 Lexium 62 Power Supplies (LXM62PD84A11000)

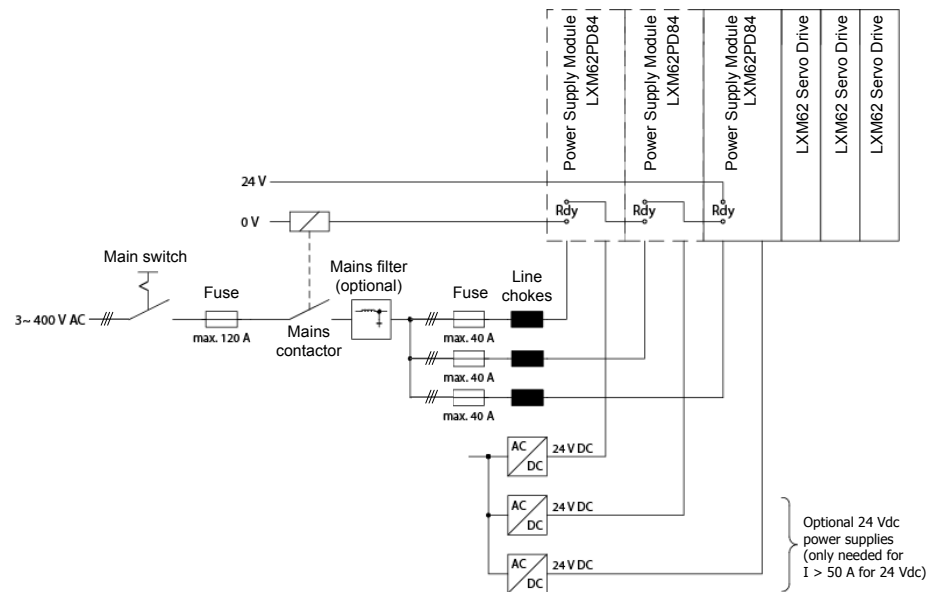

No fuses are required for the 24 Vdc supply inputs, if appropriate 24 Vdc power supply units are used which ensure that the output current remains below 50 A.

Power data for parallel connection:

Number of Lexium 62 Power Supply LXM62PD84	DC bus current		Continuous output power at 400 Vac mains input	Permissible DC bus capacity
	Continuous current	Peak current		
1	42.0 A	84.0 A	22.1 kW	12.5 mF ⁽¹⁾
2	73.9 A	147.0 A	38.9 kW	21.9 mF ⁽¹⁾
3	110.9 A	189.0 A	58.4 kW	31.3 mF ⁽¹⁾

(1) Overall sum of DC bus capacities of the devices connected to Lexium 62 Power Supply modules including the DC bus capacity of the Lexium 62 Power Supply modules themselves.

NOTE: A maximum of up to three Lexium 62 Power Supply modules of type LXM62PD84A11000 may be connected in parallel, in order not to overload the Bus Bar Module.

⚠ DANGER**FIRE, ELECTRIC SHOCK OR ARC FLASH**

- Do not install more than three Lexium 62 Power Supply modules on the same DC Bus.
- The maximum continuous current at any point of the DC link and 24V/0V connection must not exceed 120 A.

Failure to follow these instructions will result in death or serious injury.

NOTE: To calculate the maximum DC Bus current of your particular Lexium 62 Drive System, refer to *Calculation of Worst-Case Continuous Current*, page 64. If you exceed 120 A in your calculation, you need to add current-limiting fuses to the DC Bus. For further information, refer to *External Fuse*, page 66.

The parallel connection of several Lexium 62 Power Supplies of type LXM62PD20A11000 is not permitted.

Also, a mixed parallel operation of the Lexium 62 Power Supply of type LXM62PD20A11000 and Lexium 62 Power Supply of type LXM62PD84A11000 is not allowed.

Application - Mains Lines Reactor

Each Lexium 62 Power Supply (LXM62PD84A11000) must be supplied via an independent mains lines reactor. Among other reasons, the mains lines reactor provides a more uniform distribution of the load among the individual Lexium 62 Power Supply (LXM62PD84A11000).

The lines reactors must be of the same type to ensure that the load is distributed equally on the individual Lexium 62 Power Supply modules.

The mains lines reactor must be protected against overload.

Application - Mains Contactor / Ready

If a Lexium 62 Power Supply (LXM62PD84A11000) shows an error, it must be ensured that all Lexium 62 Power Supplies (LXM62PD84A11000) connected in parallel are simultaneously disconnected from the mains.

Therefore, the Ready signals of the Lexium 62 Power Supply (LXM62PD84A11000) must be connected in series and led to a common mains contactor.

In addition, it is necessary to apply line voltage to all power supplies simultaneously. The mains contactor helps ensure that all Lexium 62 Power Supply modules involved are simultaneously supplied with energy.

If you do not apply and remove line voltage to the power supplies together, you may overload the power supply system.

⚠ WARNING**OVERLOADED POWER SUPPLY**

- Ensure that all power supplies are simultaneously supplied with line voltage in a multi-power supply installation.
- Ensure that all power supplies are de-energized simultaneously.

Failure to follow these instructions can result in death, serious injury, or equipment damage.

Application - 24 V Power Supply

For machines with a 24 V supply up to 50 A, it is sufficient to use one power supply unit that is connected to any Lexium 62 Power Supply (LXM62PD84A11000).

The 24 V input is limited to 50 A per Lexium 62 Power Supply (LXM62PD84A11000).

The current per Lexium 62 Power Supply (LXM62PD84A11000) must be limited to 50 A. This can be performed, for instance, by using appropriate power supply units, which reduce the output voltage upon reaching the power limit.

A parallel connection must be approved by the power supply unit manufacturer. The overall current must not exceed 120 A.

Do not use passive power supply units with fuses for a parallel connection. They are not appropriate for a current limitation to less than 50 A since these switch off the current instead of reducing the voltage. Thus, a uniform distribution of the load is not possible with these types of power supply units.

Wiring with Lexium 62 DC Link Terminal

Overview

Wiring with Lexium 62 DC Link Terminal allows the connection of the bus bar modules of several rows of:

- Lexium 62 devices that are not directly adjacent within the same control cabinet, or
- Lexium 62 devices that are located in separate control cabinets.

When wiring with Lexium 62 DC Link Terminal, rows without power supply unit are supplied by rows with power supply units.

A row or device island is a combination of the following Lexium 62 devices which are directly connected via the bus bar module:

- Lexium 62 Power Supply
- Lexium 62 Servo Drive
- Lexium 62 DC Link Support Module
- Lexium 62 Connection Module

NOTE: Wiring with Lexium 62 DC Link Terminal is subject to electrical restrictions. Refer to the admissible topologies and to the electrical restrictions, page 61.

Topologies for Wiring with Lexium 62 DC Link Terminal

The seven topologies presented hereafter include Lexium 62 DC Link Support Modules. However, a Lexium 62 DC Link Support Module is only mandatory for longer cable lengths, page 61 or if a Single Drive LXM62DC13 is present in a row without Lexium 62 Power Supply.

NOTE: Each device island without its own Lexium 62 Power Supply requires the 24 V supply from the Lexium 62 DC Link Terminal.

NOTE:

- Wiring with Lexium 62 DC Link Terminal does not support ring topologies.
- Wiring with Lexium 62 DC Link Terminal supports a maximum of six rows or device islands.
- The 24 V and 0 V can be distributed via the Lexium 62 DC Link Terminal over several device islands.
- Instead of distributing the 24 V over several rows, an external 24 V supply can also be connected directly to the Lexium 62 DC Link Terminal for rows without Lexium 62 Power Supply modules.

DANGER

FIRE, ELECTRIC SHOCK OR ARC FLASH

Use the Lexium 62 DC Link Terminal to link Lexium 62 devices only.

Failure to follow these instructions will result in death or serious injury.

Topology 1: Coupling of Two (or More) Rows in Control Cabinet with a Separate 24 V Supply

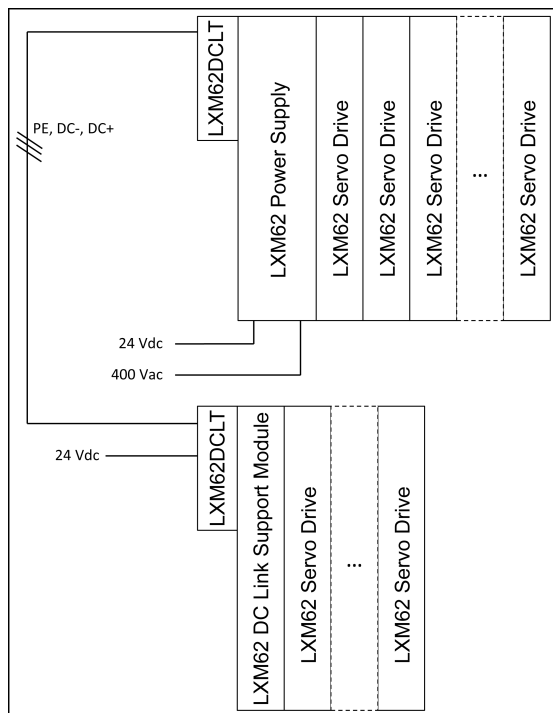

LXM62DCLT: Lexium 62 DC Link Terminal

The 24 V and 0 V terminals always have to be mounted to the Bus Bar Module, even if no wire is connected to the terminals.

⚠ DANGER

ELECTRIC SHOCK

- Always install the full complement of the five connectors and the retaining bracket of the Lexium 62 DC Link Terminal.
- Always wire at least the PE, DC- and DC+ terminals out of the 5 installed connectors.

Failure to follow these instructions will result in death or serious injury.

Topology 2: Coupling of Two (or More) Rows in a Control Cabinet Without a Separate 24 V Supply

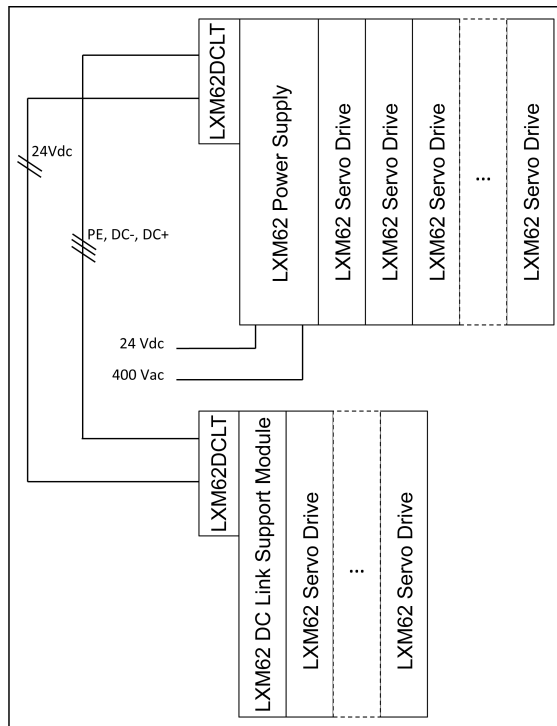

LXM62DCLT: Lexium 62 DC Link Terminal

Topology 3: Coupling of Two Power Supplies

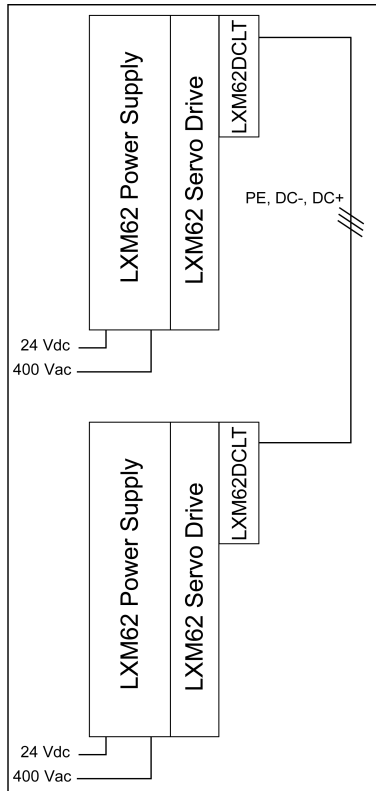

LXM62DCLT: Lexium 62 DC Link Terminal

NOTE:

- The Lexium 62 Power Supply modules are connected in parallel, page 53.
- The Lexium 62 Power Supply modules must be located in the same control cabinet.

Topology 4: Coupling of Two Control Cabinets

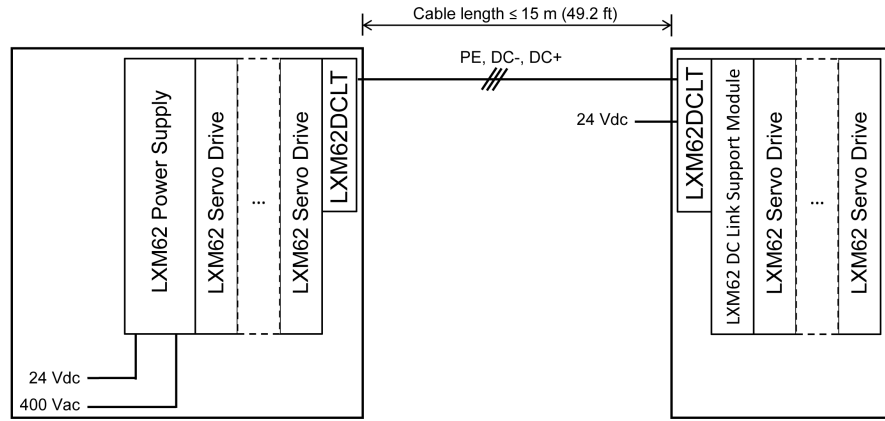

LXM62DCLT: Lexium 62 DC Link Terminal

Topology 5: Coupling of More Than Two Control Cabinets in Line Topology

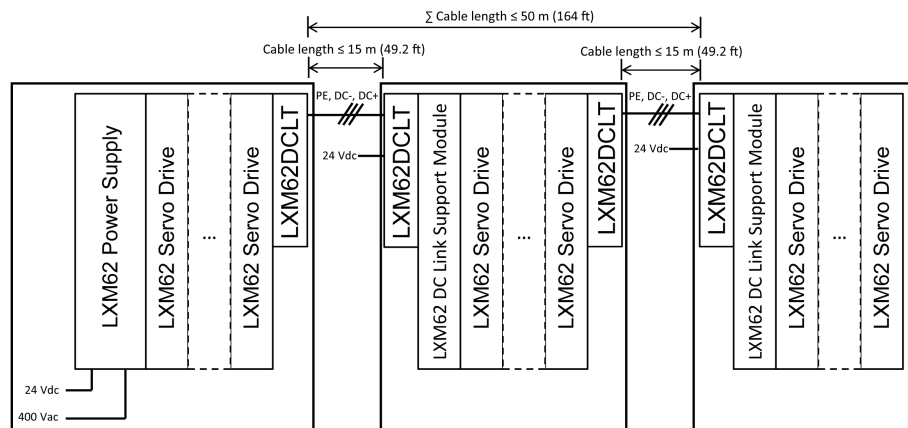

LXM62DCLT: Lexium 62 DC Link Terminal

NOTE:

- The Lexium 62 Power Supply modules must be located in the same control cabinet.
- Up to 6 Lexium 62 device islands are allowed in this topology.

Topology 6: Coupling of More Than Two Control Cabinets in Star Topology

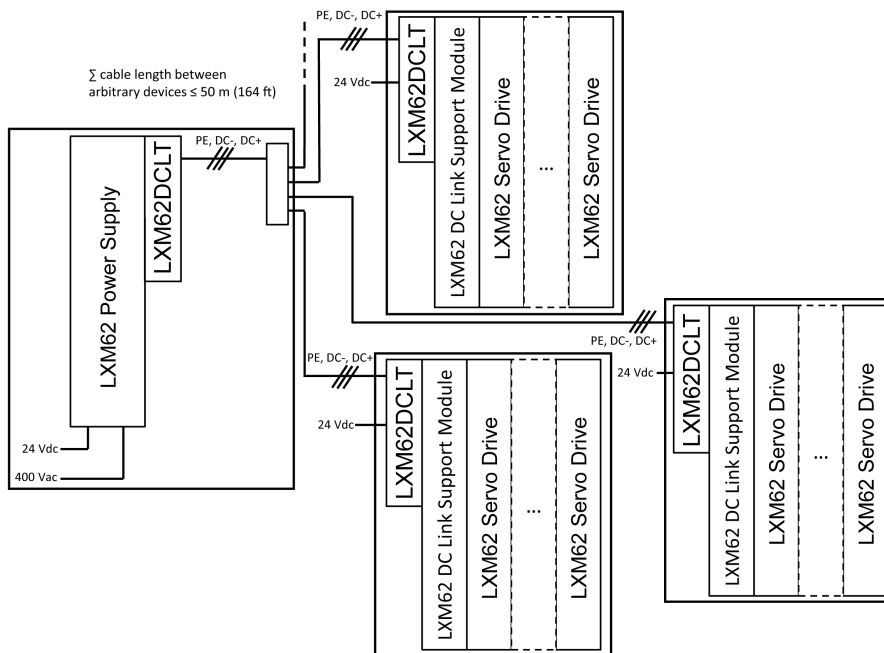

LXM62DCDCLT: Lexium 62 DC Link Terminal

NOTE:

- The Lexium 62 Power Supply modules must be located in the same control cabinet.
- Up to 6 Lexium 62 device islands are allowed in this topology.
- External terminals (for example, for cap rail) are necessary to realize star connections.
- The maximum cable length of one single connection between any Lexium 62 device island and the nearest Lexium 62 device island is 15 m (49.2 ft).

Topology 7: Coupling of More Than Two Control Cabinets in Mixed Line and Star Topology

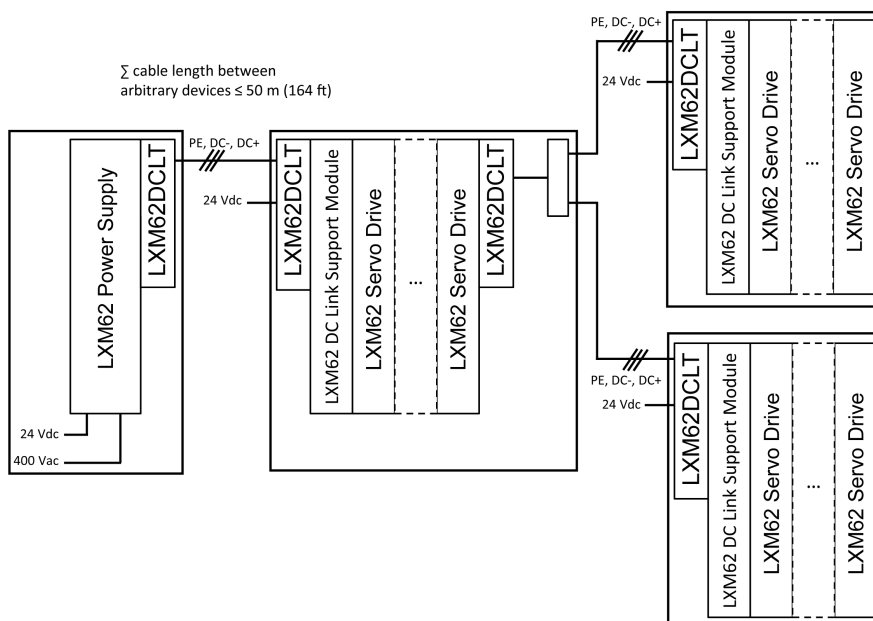

LXM62DCDCLT: Lexium 62 DC Link Terminal

NOTE:

- The Lexium 62 Power Supply modules must be located in the same control cabinet.
- Up to 6 Lexium 62 device islands are allowed in this topology.
- External terminals (for example, for cap rail) are necessary to realize star connections.

Electrical Restrictions for Wiring with Lexium 62 DC Link Terminal

Criteria	Description
Absolute cable length limits	<ul style="list-style-type: none"> • The maximum cable length of one single connection between any Lexium 62 device island and the nearest Lexium 62 device island is 15 m (49.2 ft). • The maximum overall cable length between one Lexium 62 device and any other Lexium 62 device connected using the wiring via Lexium 62 DC Link Terminal is 50 meters (164 ft).
Lexium 62 DC Link Support Module	<p>A Lexium 62 DC Link Support Module must be installed per row without Lexium 62 Power Supply if:</p> <ul style="list-style-type: none"> • the overall cable length between the row and the next row with a Lexium 62 Power Supply or Lexium 62 DC Link Support Module is longer than 3 m (9.84 ft.) • a Lexium 62 drive of type LXM62DC13 is present in the row. <p>NOTE: More than one Lexium 62 DC Link Support Module may be necessary in this case.</p> <p>NOTE: The overall cable length means the sum of single wiring connections with Lexium 62 DC Link Terminal.</p>
Power supply	<ul style="list-style-type: none"> • The Lexium 62 Power Supply modules which are connected via Lexium 62 DC Link Terminal must be located within one control cabinet. • The mains supply of the Lexium 62 Power Supply modules which are connected via Lexium 62 DC Link Terminal must be operated using the same mains contactor.
Single Drive LXM62DC13	<ul style="list-style-type: none"> • The drives of type Single Drive LXM62DC13 have to be used in combination with a Lexium 62 Power Supply or a Lexium 62 DC Link Support Module in the same row. • In a row without Lexium 62 Power Supply, one Lexium 62 DC Link Support Module has to be installed per Single Drive LXM62DC13.
Cable/wire cross section	<ul style="list-style-type: none"> • The ampacity of the Lexium 62 DC Link Terminal depends on the usage of suitable cables/wires and on the installation method of the cables/wires. • When using smaller cable/wire cross-sections, and if the system is able to drive permanently a larger current than permitted for <i>cable/wire cross-sections, page 166</i>, external fuses for current limiting must be integrated into the connection via Lexium 62 DC Link Terminal.

▲ DANGER

FIRE HAZARD

- Do not exceed an overall cable length of 3 m (9.84 ft) between any row without Lexium 62 DC Link Support Module or Lexium 62 Power Supply module and the next row with a Lexium 62 Power Supply module or Lexium 62 DC Link Support Module.
- Install a Lexium 62 DC Link Support Module for each drive of type LXM62DC13 in rows without Lexium 62 Power Supply module.
- Install all Lexium 62 Power Supply modules with linked DC Bus in the same control cabinet sharing the same mains contactor.

Failure to follow these instructions will result in death or serious injury.

⚠ DANGER**FIRE, ELECTRIC SHOCK OR ARC FLASH**

- Do not install more than three Lexium 62 Power Supply modules on the same DC Bus.
- The maximum continuous current at any point of the DC link and 24V/0V connection must not exceed 120 A.

Failure to follow these instructions will result in death or serious injury.

⚡⚠ DANGER**IMPROPER WIRING BETWEEN CONTROL CABINETS CAUSES ELECTRIC SHOCK**

- Only use appropriate and certified cables according to the applicable standards.
- Only use the cables with the appropriate cross-sections.
- Do not use individual wires outside the control cabinet; use cables only.
- Observe the bending radius of the cable/wire specification of the manufacturer.
- Thoroughly verify the cables/wires for defects and/or damages after the installation.
- Use cable ducts and other appropriate measures outside of the control cabinet protecting the cables/wires from damage and mechanical stress.
- Remove insulation accurately according to the stripping length of the cable conductor.

Failure to follow these instructions will result in death or serious injury.

⚠ WARNING**HIGH ELECTROMAGNETIC RADIATION**

- Do not exceed a cable length of 15 m (49.2 ft) for single connections using Lexium 62 DC Link Terminal.
- Do not exceed an overall cable length of 50 meters (164 ft) between one Lexium 62 device and any other Lexium 62 device connected via a Lexium 62 DC Link Terminal.

Failure to follow these instructions can result in death, serious injury, or equipment damage.

Cable Selection Guidelines for Wiring With Lexium 62 DC Link Terminal

General Requirements

The cable selection for wiring with Lexium 62 DC Link Terminal mainly depends on the continuous current. The cables must either be rated according to the worst-case continuous current or an additional external fuse must be integrated. In addition, the cable must also be chosen according to the necessary voltage isolation.

The current rating of cables and thus the cable selection also depends on environmental parameters:

- Allowed cable temperature.
- Ambient temperature and the grouping factor.
- Installation method.

Local and international regulations have to be applied.

DANGER

IMPROPER WIRING BETWEEN CONTROL CABINETS CAUSES ELECTRIC SHOCK

- Only use appropriate and certified cables according to the applicable standards.
- Only use the cables with the appropriate cross-sections.
- Do not use individual wires outside the control cabinet; use cables only.
- Observe the bending radius of the cable/wire specification of the manufacturer.
- Thoroughly verify the cables/wires for defects and/or damages after the installation.
- Use cable ducts and other appropriate measures outside of the control cabinet protecting the cables/wires from damage and mechanical stress.
- Remove insulation accurately according to the stripping length of the cable conductor.

Failure to follow these instructions will result in death or serious injury.

Calculation of Worst-Case Continuous Current

Calculation of the worst-case 24 V/0 V continuous current

If no external fuses are installed within a 24 V/0 V wiring connection using Lexium 62 DC Link Terminals, then the cable for each single 24 V/0 V connection must be rated for the worst-case continuous current. The latter is given by the sum of the rated currents of the connected 24 V power supply modules.

NOTE: If the worst-case continuous 24 V/0 V current is larger than 120 A, then it is mandatory to install external fuses within the 24 V/0 V wiring connection to limit the continuous current to 120 A or less.

Calculation of the worst-case DC+/DC- continuous current

If no external fuses are installed within a DC+/DC- wiring connection using Lexium 62 DC Link Terminals, then the cable for each single DC+/DC- connection must be rated for the worst-case continuous current.

NOTE: If the worst-case continuous DC+/DC- current is larger than 120 A, then it is mandatory to install external fuses within the DC+/DC- wiring connection to limit the continuous current to 120 A or less.

The maximum continuous DC circuit current over the wiring connection can be computed as follows:

- Look up the nominal power for each motor-drive combination in the system (nominal power of a motor-drive combination is the minimum of the nominal power values of the drive and of the motor) and for the Lexium 62 Power Supply modules.

NOTE: Always use the values for 400 Vac nominal mains voltage, even if the machine is installed at 480 Vac.
- Sum up the nominal power values of the motor-drive combinations and the Lexium 62 Power Supply modules in the system which are installed to the left of the Lexium 62 DC Link Terminal wiring connection. (In case several Lexium 62 Power Supply modules are connected in parallel, consult the table *Power data for parallel connection*, page 53 for the resulting overall continuous output power rating of the parallel connected Lexium 62 Power Supply modules).
- Sum up the nominal power values of the motor-drive combinations and the Lexium 62 Power Supply modules in the system which are installed to the right of the Lexium 62 DC Link Terminal wiring connection. (In case several Lexium 62 Power Supply modules are connected in parallel, consult the table *Power data for parallel connection*, page 53 for the resulting overall continuous output power rating of the parallel connected Lexium 62 Power Supply modules).
- Take the minimum value of these two nominal power sums (to obtain the maximum continuous power generated by motor-drive combinations and Lexium 62 Power Supply modules which could be transferred over the Lexium 62 DC Link Terminal wiring connection).
- Divide this maximum continuous power by 540 V (equals the DC bus voltage at 400 Vac mains) to obtain the maximum continuous DC circuit current for the wiring connection.

NOTE: Even if the system is supplied with 480 Vac, the DC bus voltage 540 V corresponding to 400 Vac must be used for the calculation, provided that also the continuous power values corresponding to 400 Vac are applied.

Example for Continuous DC+/DC- Current Rating Calculation

Consider the Lexium 62 Drive System configuration outlined below.

Assume that:

- The Lexium 62 Power Supply modules P1 and P2 are connected in parallel and they are supplied with 400 Vac.
- The Lexium 62 drives are operated at the PWM frequency 8 kHz.
- The system is rated for a maximum ambient temperature of 40 °C (104 °F).

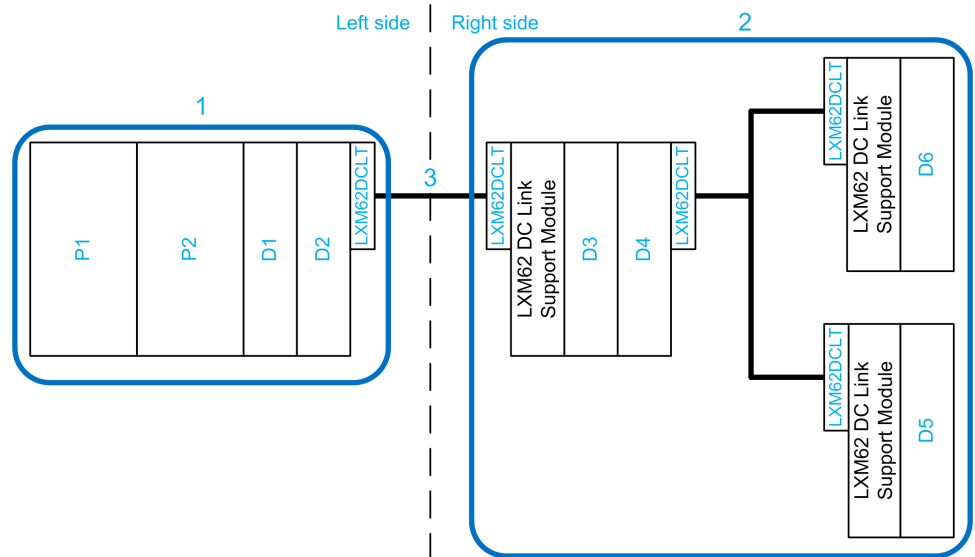

1 Lexium 62 drive islands to the left of Lexium 62 DC Link Terminal wiring connection

2 Lexium 62 drive islands to the right of Lexium 62 DC Link Terminal wiring connection

3 Lexium 62 DC Link Terminal wiring connection for which continuous DC+/DC- current rating is calculated

LXM62DCLT Lexium 62 DC Link Terminal

Reference	Drive	Continuous Drive Power $P_{N, LXM62D}$ or $P_{N, LXM62P}$	Motor	Continuous Motor Power $P_{N, Mot}$	Continuous power of drive-motor combination or parallel connected Lexium 62 Power Supply modules
P1+P2	LXM62PD84	N/A	N/A	N/A	38.9 kW ⁽¹⁾
D1	LXM62DD27E	3.4 kW ⁽²⁾	SH31003P	2.39 kW ⁽³⁾	2.39 kW ⁽⁴⁾
D2	LXM62DD27E	3.4 kW ⁽²⁾	SH31003P	2.39 kW ⁽³⁾	2.39 kW ⁽⁴⁾
D3	LXM62DD27E	3.4 kW ⁽²⁾	SH31003P	2.39 kW ⁽³⁾	2.39 kW ⁽⁴⁾
D4	LXM62DD27E	3.4 kW ⁽²⁾	SH31003P	2.39 kW ⁽³⁾	2.39 kW ⁽⁴⁾
D5	LXM62DD27E	3.4 kW ⁽²⁾	SH31003P	2.39 kW ⁽³⁾	2.39 kW ⁽⁴⁾
D6	LXM62DD27E	3.4 kW ⁽²⁾	SH31003P	2.39 kW ⁽³⁾	2.39 kW ⁽⁴⁾

(1) See *Power data for parallel connection*, page 53

(2) See *Technical Data Single Drive*, page 173

(3) See *SH3 Servo Motor - User Guide* (see SH3 Servo Motor, User Guide)

(4) The continuous power of a motor-drive combination is the minimum of the continuous drive power and the continuous motor power.

The continuous power sum to the left of the Lexium 62 DC Link Terminal wiring connection is:

$$\begin{aligned} P_{\text{left}} &= P_{N,P1+P2} + P_{N,D1} + P_{N,D2} \\ &= 38.9 \text{ kW} + 2.39 \text{ kW} + 2.39 \text{ kW} \\ &= 43.7 \text{ kW} \end{aligned}$$

The continuous power sum to the right of the Lexium 62 DC Link Terminal wiring connection is:

$$\begin{aligned} P_{\text{right}} &= P_{N,D3} + P_{N,D4} + P_{N,D5} + P_{N,D6} \\ &= 2.39 \text{ kW} + 2.39 \text{ kW} + 2.39 \text{ kW} + 2.39 \text{ kW} \\ &= 9.6 \text{ kW} \end{aligned}$$

The maximum continuous power to the right side is lower than the power to the left side of the Lexium 62 DC Link Terminal wiring connection. So, the DC+/DC- wires of the Lexium 62 DC Link Terminal wiring connection can be rated for the maximum continuous power to the right side. The maximum continuous DC+/DC-current over the Lexium 62 DC Link Terminal wiring connection is then:

$$I_{dc} = \frac{P_{\text{right}}}{540V} = \frac{9.6 \text{ kW}}{540V} = 17.8 \text{ A}$$

Thus, in this example, external fuses within the DC+/DC- connection of the Lexium 62 DC Link Terminal wiring connection can be omitted if the corresponding DC+/DC- cable/wire installation is rated for at least 17.8 A.

NOTE: If the resulting continuous DC+/DC- current is greater than 120 A, an external fuse within the DC+/DC- connection is mandatory to limit the current to 120 A or less.

External Fuse

The cross section of the wires (DC+, DC-, 0 V, 24 V) of a Lexium 62 DC Link Terminal wiring connection can be reduced if they are protected by external fuses. The DC+/DC- fuses must be rated for 1000 Vdc and the 0 V/24 V fuses must be rated for 30 Vdc. The fuses must provide a protection against short circuits and overload (gR, gN, or gG). The DC rating is important because a fuse which only has an AC rating is not able to protect the circuit.

Use one fuse per current carrying conductor (DC+, DC-, 0 V, 24 V). If the worst-case continuous current of any current carrying conductor (DC+, DC-, 0 V, 24 V) is greater than 120 A, install external fuses to limit the continuous current to 120 A or less. Do not install a fuse on the PE conductor.

Isolation Voltage Requirements

Required cable voltage isolation for wiring using Lexium 62 DC Link Terminal:

PE / DC- / DC+ / 24 V / 0 V wire: 1000 Vdc (>700 Vac)

Leakage Current

Overview

The following table contains leakage current per device:

Application	Per power supply	For each drive module
Typical (400 V, 50 Hz)	≤ 141 mA	≤ 9 mA

NOTE: If the leakage current is too high for the respective application, use an isolating transformer on the mains supply.

This product has a leakage current greater than 3.5 mA. If the protective ground connection is interrupted, a hazardous touch current may flow if the housing is touched.

DANGER

INSUFFICIENT GROUNDING

- Use a protective ground copper conductor with at least 10 mm² (AWG 6) or two protective ground copper conductors with the same or larger cross section of the conductors supplying the power terminals.
- Verify compliance with all local and national electrical code requirements as well as all other applicable regulations with respect to grounding of all equipment.

Failure to follow these instructions will result in death or serious injury.

Residual Current Operated Protective Device

Using Residual Current Protective Devices

When using a residual current protective device in combination with the Lexium 62 Drive System, certain conditions and restrictions must be considered. As a dc current component in the ground conductor may result from insulation damage or direct contact, residual current circuit-breakers of type A or AC may not be triggered and therefore must not be used. Moreover, during system power-up and also in normal operation the Lexium 62 Drive System can generate a significant leakage current, page 67 which may lead to unintended triggering of a residual current protective device.

Consequently, observe the following when using residual current protective devices in combination with the Lexium 62 Drive System:

- Only use universal current sensitive residual current circuit-breaker of type B.
- Use residual current protective devices with a latent time to prevent unintended triggering at system power-up.
- Consider the leakage current of the Lexium 62 Drive System in normal operation when selecting the triggering threshold of the residual current protective device.
- If no residual current protective device or only a device with a high current threshold can be installed, appropriate other measures must be applied to provide protection against electrical shock and fire hazard

Functional Safety

Process Minimizing Risks Associated with the Machine

General

The goal of designing machines safely is to protect people. The risk associated with machines with electrically controlled drives comes chiefly from moving machine parts and electricity itself.

Only you, the user, machine builder, or system integrator can be aware of all the conditions and factors realized in the design of your application for the machine. Therefore, only you can determine the automation equipment and the related safeties and interlocks which can be properly used, and validate such usage.

Hazard and Risk Analysis

Based on the system configuration and utilization, a hazard and risk analysis must be carried out for the system (for example, according to ISO 12100 or ISO 13849-1). The results of this analysis must be considered when designing the machine, and subsequently applying safety-related equipment and safety-related functions. The results of your analysis may deviate from any application examples contained in the present or related documentation. For example, additional safety components may be required. In principle, the results from the hazard and risk analysis have priority.

⚠ WARNING

NON-CONFORMANCE TO SAFETY FUNCTION REQUIREMENTS

- Specify the requirements and/or measures to be implemented in the risk analysis you perform.
- Verify that your safety-related application complies to applicable safety regulations and standards.
- Make certain that appropriate procedures and measures (according to applicable sector standards) have been established to help avoid hazardous situations when operating the machine.
- Use appropriate safety interlocks where personnel and/or equipment hazards exist.
- Validate the overall safety-related function and thoroughly test the application.

Failure to follow these instructions can result in death, serious injury, or equipment damage.

The ISO 13849-1 Safety of machinery - Safety-related parts of control systems - Part 1: General principle for design describes an iterative process for the selection and design of safety-related parts of controllers to reduce the risk to the machine to a reasonable degree:

To perform risk assessment and risk minimization according to ISO 12100, proceed as follows:

1. Defining the boundary of the machine.
2. Identifying risks associated with the machine.
3. Assessing risks.
4. Evaluating risks.
5. Minimizing risks by:
 - Intrinsically safe design
 - Protective devices
 - User information (see ISO 12100)
6. Designing safety-related controller parts (SRP/CS, Safety-Related Parts of the Control System) in an interactive process.

To design the safety-related controller parts in an interactive process, proceed as follows:

Step	Action
1	Identify necessary safety functions that are executed via SRP/CS (Safety-Related Parts of the Control System).
2	Determine required properties for each safety function.
3	Determine the required performance level PL_r .
4	Identify safety-related parts executing the safety function.
5	Determine the performance level PL of the afore-mentioned safety-related parts.
6	Verify the performance level PL for the safety function ($PL \geq PL_r$).
7	Verify if all requirements have been met (validation).

Additional information is available on www.se.com.

Inverter Enable Function

Functional Description

With the Inverter Enable function (IE), you can bring drives to a defined safe stop.

This Inverter Enable function relates to the components

- Single Drive
- Double Drive

In the sense of the relevant standards, the requirements of the stop category 0 (Safe Torque Off, STO) and stop category 1 (Safe Stop 1, SS1) can be met. Both categories lead to a torque-free motor while SS1 takes this state after a predefined time. As a result of the hazard and risk analysis, it may be necessary to choose an additional brake as a safety-related option (for example, for hanging loads).

With the Lexium 62 variants E/F, it is also possible to realize extended safety functions such as Safely Limited Speed (SLS) in connection with the Safety Logic Controller TM5CSLC•00FS and the associated EcoStruxure Machine Expert - Safety software.

Scope of Operation (Designated Safety Function)

The Lexium 62 Servo Drives are available in the Inverter Enable two-channel variants C/D/G. The variants C/D/G were developed to execute the Inverter Enable function according to SIL 3 or PL e. For this purpose, there must be a two-channel connection. Thus, the device variants C/D/G have the additional connection **CN11**.

Reaching SIL 3 / PL e / Category 4 is limited to 100 axes per safety function.

The variants C/D/G may be connected in a single-channel configuration. The second contact, in this case is jumpered. For this purpose, a separate application proposal is provided (For further information, refer to *Application Proposal – Variants C/D/G Single-Channel Jumpered*, page 84).

The two-channel variants C/D/G can be connected under different conditions in which certain potential errors can be ruled out. If a potential error cannot be ruled out, additional measures are required (test pulses or diagnostic).

As a result, there are the following additional application proposals for a pure two-channel application:

- *Application proposal variants C/D/G two-channel with protected wiring*, page 85
- *Application proposal variants C/D/G two-channel with test pulses*, page 88
- *Application proposal variants C/D/G two-channel with external, non-safety-related diagnostic*, page 89

Since the variants C/D/G can be connected in a single-channel or a two-channel configuration, it results in a combination of the applications. To verify this application for the correct connection, a test procedure is provided.

Operating Principle

- After the emergency stop device is activated, a controlled ramp down takes place for the drive.
- In the process, the DC bus voltage increases until the braking resistor is switched on.
- In the braking resistor, the energy which is fed back from the motor is converted to heat.
- The K1 power circuit breaker and/or the Inverter Enable signal must remain energized until the drive stops.

- At the latest after the normal ramp down time, the Inverter Enable signal is switched off by the delayed contacts of K3.
- After this, the drive is in a defined safe stop.

Inverter Enable block diagram:

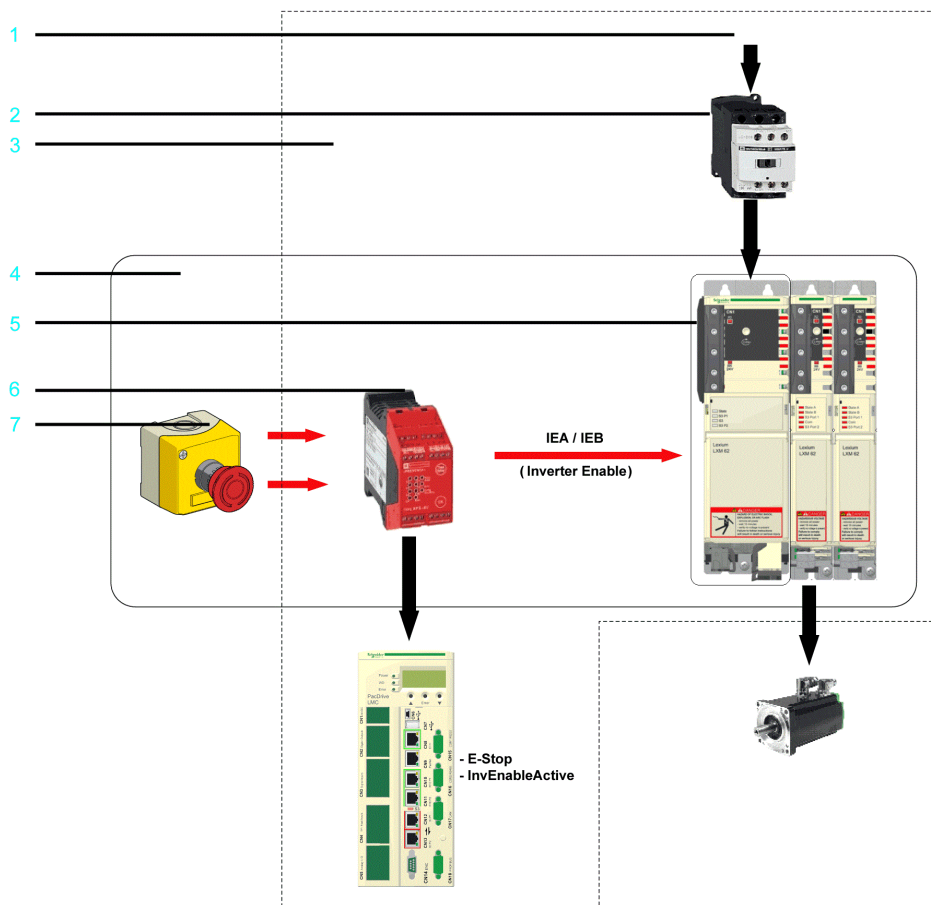

- 1 3 Phase (AC)
- 2 Mains Contactor K1
- 3 IP54 (control cabinet) or higher
- 4 Part of the safety function
- 5 Power supply of the Lexium 62 Drive System (**not** part of the safety function)
- 6 Safety-related switching device K3
- 7 Emergency stop button

Defined Safe State

Inverter Enable is synonymous with "Safe Torque Off (STO)" according to IEC 61800-5-2. This torque-free state is automatically entered when errors are detected and is therefore the defined safe state of the drive.

Mode of Operation

The safety-related circuit with InverterEnable was developed to minimize wear on the mains contactor. When the stop or the emergency stop button is activated, the mains contactor is not switched off. The defined safe stop is achieved by removing the "InverterEnable" for the opto-couple in the power stage. Thus, the PWM signals cannot control the power stage so that a startup of the drives is prevented (pulse pattern lock).

You can use the Inverter Enable function to implement the control function “Stopping in case of emergency” (EN 60204-1) for stop categories 0 and 1. Use an appropriate external safety-related circuit to prevent the unintended restart of the drive after a stop, as required in the machine directive.

Stop Category 0

In stop category 0 (Safe Torque Off, STO), the drive coasts to a stop (provided there are no external forces operating to the contrary). The STO safety-related function is intended to help prevent an unintended start-up, not stop a motor, and therefore corresponds to an unassisted stop in accordance with IEC 60204-1.

In circumstances where external influences are present, the coast down time depends on physical properties of the components used (such as weight, torque, friction, and so on), and additional measures such as mechanical brakes may be necessary to help prevent any hazard from materializing. That is to say, if this means a hazard to your personnel or equipment, you must take appropriate measures (refer to *Hazard and Risk Analysis*, page 69).

▲ WARNING

UNINTENDED EQUIPMENT OPERATION

- Make certain that no hazards can arise for persons or material during the coast down period of the axis/machine.
- Do not enter the zone of operation during the coast down period.
- Ensure that no other persons can access the zone of operation during the coast down period.
- Use appropriate safety interlocks where personnel and/or equipment hazards exist.

Failure to follow these instructions can result in death, serious injury, or equipment damage.

Stop Category 1

For stops of category 1 (Safe Stop 1, SS1) you can request a controlled stop via the Logic Motion Controller. The controlled stop by the Logic Motion Controller is not safety-relevant, nor monitored, and does not perform as defined in the case of a power outage or if an error is detected. The final switch off in the defined safe state is accomplished by switching off the *Inverter Enable* input. This has to be implemented by using an external safety-related switching device with safety-related delay (refer to application proposal, page 83).

Independent of the safety function, the detectable errors not affecting the safety function are recognized by the controller, thus avoiding the drive from starting by switching off the mains contactor. Contactor K2 prevents the mains contactor from being switched on.

Execute Muting

To execute muting, determine the muting reaction time for switching off, that is, without the Inverter Enable function, within the application. Should a response time be required because of the risk assessment of the machine, the total response time of the machine has to be taken into account. That is to say, the components related to the safety functions from the sensor to the drive shaft or the driven mechanics have to be considered. The determined reaction time must correspond to the results of the hazard and risk analysis.

⚠ WARNING

UNINTENDED EQUIPMENT OPERATION

- Verify that the maximum response time corresponds to your risk analysis.
- Be sure that your risk analysis includes an evaluation for the maximum response time.
- Validate the overall function with regard to the maximum response time and thoroughly test the application.

Failure to follow these instructions can result in death, serious injury, or equipment damage.

Proceed as follows to disable the Inverter Enable function:

Supply the IEA or IEB input constantly with 24 Vdc to deactivate the Inverter Enable function.

The axes without Inverter Enable function become torque-free via the mains contactor and come to a stop. For further information, refer to *Stop Category 0*, page 73.

Extended Safety-Related Functions - Operating Principle

The safety concept is based upon the general consideration that the required safety-related travel movement is performed by the controller and the drive. The safety system monitors the correct execution of the motion, and if it is not respected the safety system initiates the required fall-back level (for example the defined safe state).

An example for Safe Limited Speed (SLS) is as follows:

A light curtain is connected to a safety-related digital input. As soon as a person enters the protected zone passing the light curtain, the corresponding information is transmitted to the Safety Logic Controller (SLC) and the Logic Motion Controller (LMC) via the Sercos bus. After that the Logic Motion Controller initiates an adequate travel movement, for example by using decelerating and then moving slowly. After an adjustable delay time, this slow movement is monitored by Lexium 62 variants E/F. Upon exceeding an adjustable threshold value (for example, high velocity), the required fall-back level is entered, for example, the defined safe state.

Application of safety-related function SLS:

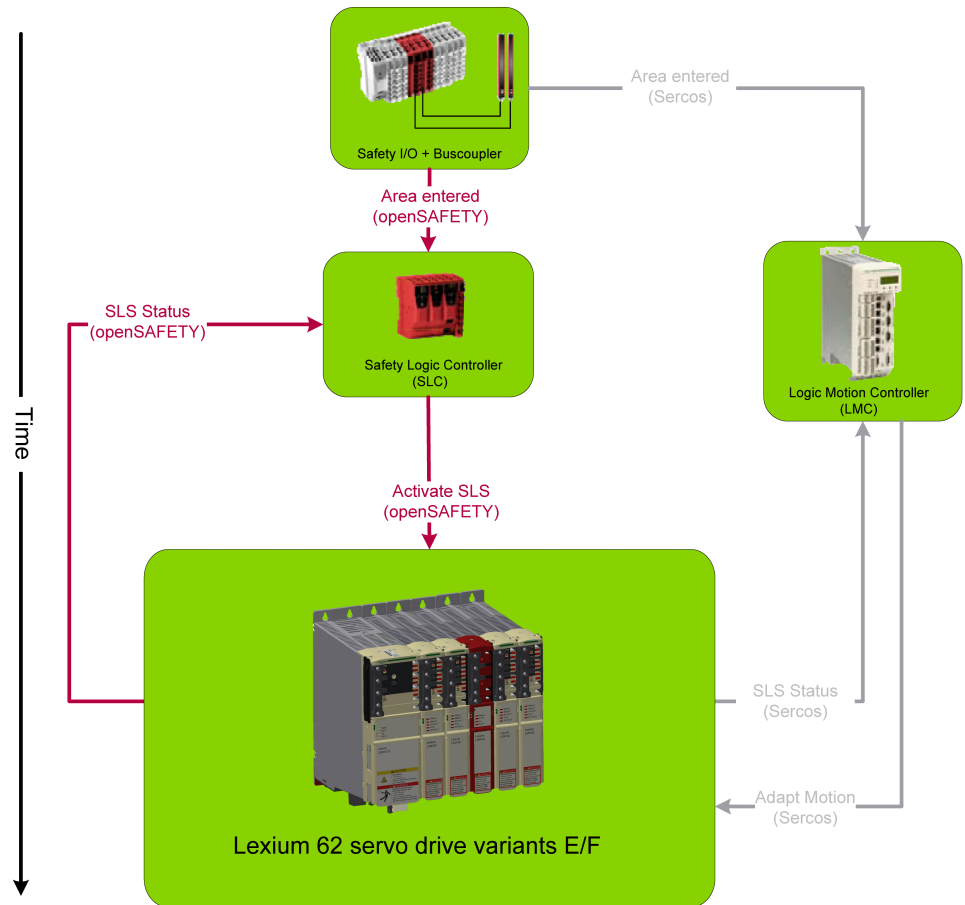

Extended Safety-Related Functions - Inverter Enable via Hardware Input

The Lexium 62 variants E/F have been primarily developed to realize the extended safety functions. They are equipped with the hardware input for the Inverter Enable 2-channel on connector **CN11**. The connector **CN6** also supports the Inverter Enable 1-channel for the variants C/D/G. However, only this Inverter Enable 2-channel function must be used for the Lexium 62 variants E/F. The device still needs to be configured and parameterized by using the software. If it is hardwired, the **Safe Torque Off (STO)** function can be triggered via the Inverter Enable inputs IEA/IEB or the Sercos bus. The Lexium 62 Drive System Safety Module can be configured to ignore the hardware input. In this case, the Safe Torque Off (STO) function can only be activated upon a request over the Sercos bus. Otherwise, if the hardware input is not ignored then both requests (hardware input and Sercos bus) are verified and the Safe Torque Off (STO) function is triggered if one or both requests are active. The default configuration takes into account the hardware input.

⚠ DANGER

INADEQUATE SAFETY FUNCTION

Do not use 1-channel Inverter Enable wiring with Lexium 62 variants E/F.

Failure to follow these instructions will result in death or serious injury.

Extended Safety-Related Functions - Defined Safe State

The defined safe state of the device is characterized by the following features:

- The drive is torque-free, which is equivalent to **Safe Torque Off (STO)** according to IEC 61800-5-2.
- There is no safety-related communication from the drive via the Sercos bus.

This state is automatically entered when errors are detected.

Validity of the Safety Case

The safety case for the Inverter Enable function of the Lexium 62 Drive System is identified and defined by the standards listed in *Safety Standards*, page 98. The safety case of the Lexium 62 Drive System Inverter Enable function applies to the following hardware codes, which can be found examining the appropriate software object in the *EcoStruxure Machine Expert - Programming Guide*, page 8:

Servo Drives

Drive	Hardware code
LXM62DU60C	xxxxxxxxxx1xxx, xxxxxxxxxxxx2xxx, xxxxxxxxxxxx3xxx, xxxxxxxxxxxx4xxx, xxxxxxxxxxxx5xxxx, xxxxxxxxxxxx6xxxx, xxxxxxxxxxxx7xxxx
LXM62DD15C	xxxxxxxxxx1xxx, xxxxxxxxxxxx2xxx, xxxxxxxxxxxx3xxx, xxxxxxxxxxxx4xxx, xxxxxxxxxxxx5xxxx, xxxxxxxxxxxx6xxxx, xxxxxxxxxxxx7xxxx
LXM62DD27C	xxxxxxxxxx1xxx, xxxxxxxxxxxx2xxx, xxxxxxxxxxxx3xxx, xxxxxxxxxxxx4xxx, xxxxxxxxxxxx5xxxx, xxxxxxxxxxxx6xxxx, xxxxxxxxxxxx7xxxx
LXM62DD45C	xxxxxxxxxx1xxx, xxxxxxxxxxxx2xxx, xxxxxxxxxxxx3xxx, xxxxxxxxxxxx4xxx, xxxxxxxxxxxx5xxxx, xxxxxxxxxxxx6xxxx, xxxxxxxxxxxx7xxxx
LXM62DC13C	xxxxxxxxxxxxxxxx1xxx, xxxxxxxxxxxxxxxx2xxx, xxxxxxxxxxxxxxxx3xxx, xxxxxxxxxxxxxxxx4xxx, xxxxxxxxxxxxxxxx5xxx
LXM62DU60D	xxxxxxxxxx1xxx, xxxxxxxxxxxx2xxx, xxxxxxxxxxxx3xxx, xxxxxxxxxxxx4xxx, xxxxxxxxxxxx5xxxx, xxxxxxxxxxxx6xxxx, xxxxxxxxxxxx7xxxx
LXM62DD15D	xxxxxxxxxx1xxx, xxxxxxxxxxxx2xxx, xxxxxxxxxxxx3xxx, xxxxxxxxxxxx4xxx, xxxxxxxxxxxx5xxxx, xxxxxxxxxxxx6xxxx, xxxxxxxxxxxx7xxxx
LXM62DD27D	xxxxxxxxxx1xxx, xxxxxxxxxxxx2xxx, xxxxxxxxxxxx3xxx, xxxxxxxxxxxx4xxx, xxxxxxxxxxxx5xxxx, xxxxxxxxxxxx6xxxx, xxxxxxxxxxxx7xxxx

Advanced Servo Drives

Drive	Hardware code
LXM62DU60G	xxxxxxxxxx5xxxx, xxxxxxxxxxxx6xxxx, xxxxxxxxxxxx7xxxx
LXM62DD15G	xxxxxxxxxx5xxxx, xxxxxxxxxxxx6xxxx, xxxxxxxxxxxx7xxxx
LXM62DD27G	xxxxxxxxxx5xxxx, xxxxxxxxxxxx6xxxx, xxxxxxxxxxxx7xxxx
LXM62DD45G	xxxxxxxxxx5xxxx, xxxxxxxxxxxx6xxxx, xxxxxxxxxxxx7xxxx
LXM62DC13G	xxxxxxxxxx5xxxx

Servo Drives with Embedded Safety

Drive	Hardware code
LXM62DU60E	01xxxxxxxx11xx, 01xxxxxxxx21xx, 01xxxxxxxx31xx, 10xxxxxxxx41xxxx, 10xxxxxxxx51xxxx
LXM62DD15E	01xxxxxxxx11xx, 01xxxxxxxx21xx, 01xxxxxxxx31xx, 10xxxxxxxx41xxxx, 10xxxxxxxx51xxxx
LXM62DD27E	01xxxxxxxx11xx, 01xxxxxxxx21xx, 01xxxxxxxx31xx, 10xxxxxxxx41xxxx, 10xxxxxxxx51xxxx
LXM62DD45E	01xxxxxxxx11xx, 01xxxxxxxx21xx, 01xxxxxxxx31xx, 10xxxxxxxx41xxxx, 10xxxxxxxx51xxxx
LXM62DC13E	01xxxxxxxxxxxx11xx, 01xxxxxxxxxxxx21xx, 02xxxxxxxxxxxx31xx, 10xxxxxxxxxxxx41xxxx
LXM62DU60F	01xxxxxxxx21xx, 01xxxxxxxx31xx, 10xxxxxxxx41xxxx, 10xxxxxxxx51xxxx
LXM62DD15F	01xxxxxxxxxxxx11xx, 01xxxxxxxxxxxx21xx, 02xxxxxxxxxxxx31xx, 10xxxxxxxxxxxx41xxxx
LXM62DD27F	01xxxxxxxxxxxx11xx, 01xxxxxxxxxxxx21xx, 02xxxxxxxxxxxx31xx, 10xxxxxxxxxxxx41xxxx

For additional information, contact your Schneider Electric representative.

Interface and Control

The Inverter Enable function is operated via the switching thresholds of the Inverter Enable input (IEA for axis A and IEB for axis B).

- Maximum downtime: 500 μ s at $U_{IEX} > 20$ V with dynamic control
- Maximum test pulse ratio: 1 Hz
- STO active: -3 V $\leq U_{IEX} \leq 5$ V
- Power stage active: 18 V $\leq U_{IEX} \leq 30$ V

For further information on the technical data and electrical connections, refer to the chapter *Technical Data*, page 167.

Setup, Installation and Maintenance

Prevent Possible Unintended Operation and Avoid Overvoltage

The following measures avoid overvoltages and help prevent possible unintended equipment operation through conductive pollution or parts falling into the device:

⚠ DANGER

ELECTRIC SHOCK, EXPLOSION, OR ARC FLASH

- Install Lexium 62 in a control cabinet or housing with a minimum IP 54 rating.
- Comply with the clearances and creepage distances according to EN 50178.
- Lexium 62 must only be operated with 24 Vdc power supplies certified according to EN 60950 or EN 50178.

Failure to follow these instructions will result in death or serious injury.

NOTE: These power supply units do not deliver an overvoltage over 120 Vdc for more than 120 ms or no permanent overvoltage over 60 Vdc.

Only operate the drive system with approved, specified cables, accessories and replacement equipment by Schneider Electric.

⚠ DANGER

ELECTRIC SHOCK OR ARC FLASH

Do not use non-Schneider Electric approved cables, accessories or any type of replacement equipment.

Failure to follow these instructions will result in death or serious injury.

Avoid Unintentional Restart

The unintentional restart of the equipment must be avoided by appropriate means, depending on your particular application.

⚠ DANGER

UNINTENTIONAL RESTART OF THE MOTOR

- Ensure that a restart of the motor is not possible after a return of power or the tripping of a functional safety device unless preceded by a deliberate enable signal from the system.
- Ensure that the enable signal meets the specified safety criteria.

Failure to follow these instructions will result in death or serious injury.

Encoder Connection When Using Extended Safety-Related Functions

Lexium 62 variants E/F enable the use of extended, position-dependent and/or velocity-dependent safety-related functions. Among other things, these safety-related functions require encoder signals. The use of third-party encoders may present a degradation or loss of the safety functions.

DANGER

INOPERABLE SAFETY FUNCTION

- Use synchronous motors only.
- Use the encoder signals that are also used for the drive control of the synchronous motors.
- Only use SinCos encoders according to the requirements and assumptions of IEC 61800-5-2.

Failure to follow these instructions will result in death or serious injury.

Setup, Installation, and Maintenance - Wiring Verification

Overview

For mixed applications for the Lexium 62 variants C/D/G and Lexium 62 variants E/F with a two-channel Inverter Enable connection (*Application proposal variants C/D/G single-channel jumpered*, page 84 and *Application proposal variants C/D/G two-channel with protected wiring*, page 85) for the Lexium 62 variants C/D/G with a two-channel Inverter Enable connection, a verification of the wiring has to be performed as follows.

Determine Status of Inverter Enable in EcoStruxure Machine Expert Logic Builder

The state of the Inverter Enable input is displayed in the EcoStruxure Machine Expert Logic Builder. This can be used to determine if the drives are correctly wired 1-channel or 2-channel.

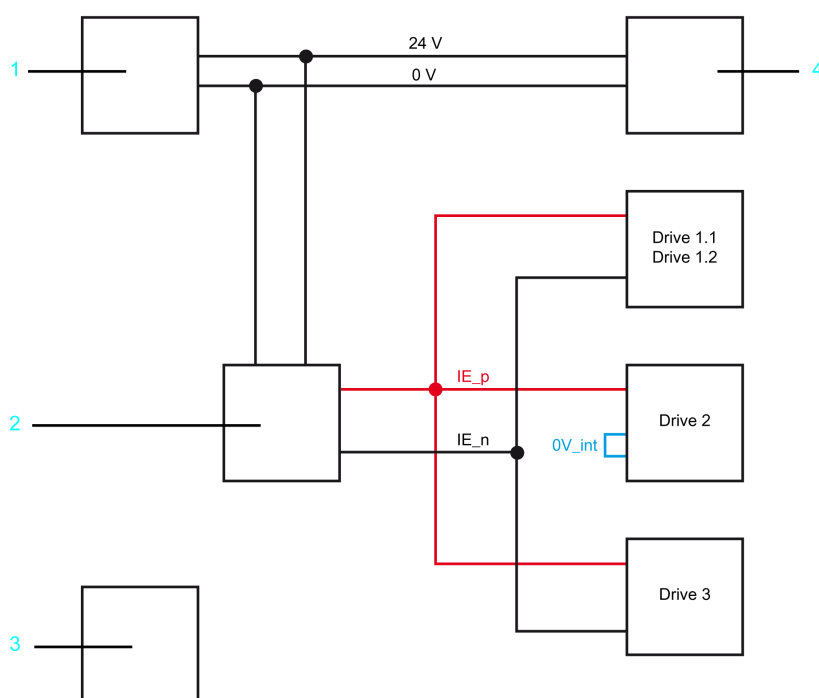

- 1 24 V power supply unit
- 2 Safety-related switching device
- 3 24 V external power supply unit
- 4 Lexium 62 Power Supply

Measuring Procedure

Step	Action
1	Wire Inverter Enable channels and connect the connectors to the drives.
2	Disconnect the IE_p connection (24 V) for the drives on the safety-related switching device (see step 1 in the following graphic).
3	Connect the disconnected IE_p connection (24 V) to an external 24 V power supply unit (see step 2 in the following graphic).
4	The negative pole of the Lexium 62 Power Supply has to be connected to the 0 V of the drives (Connector CN5 PIN 1 of the Lexium 62 Power Supply (see step 3 in the following graphic)).

Verifying the 1-channel wiring

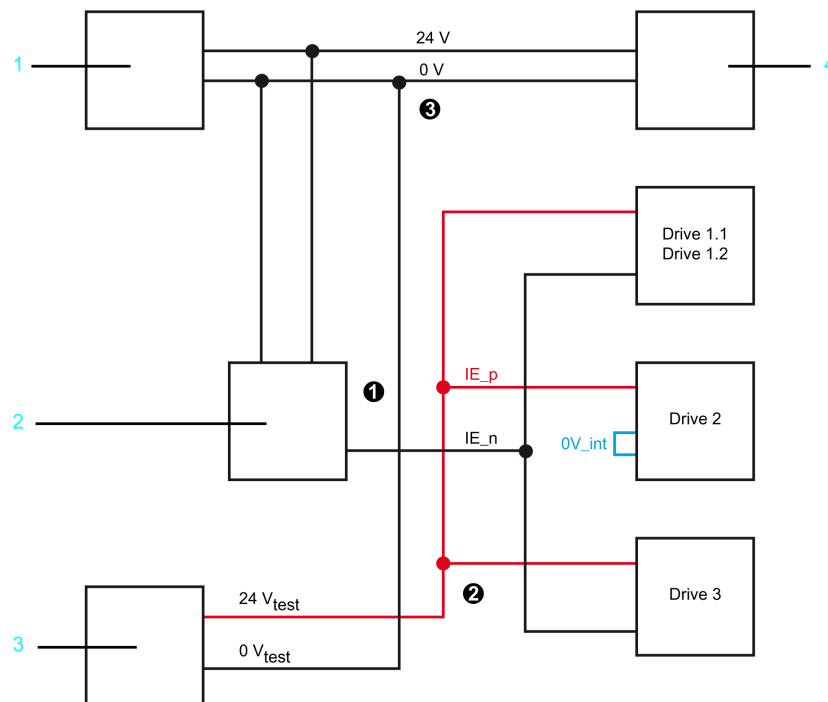

- 1 24 V power supply unit
- 2 Safety-related switching device
- 3 24 V external power supply unit
- 4 Lexium 62 Power Supply

Step	Action
5	Verify the IE (Inverter Enable) state of every individual drive in EcoStruxure Machine Expert Logic Builder. Result: In this case, only the 1-channel drives may be active.
6	Record the status values in a table. If necessary, screenshots can also be created in EcoStruxure Machine Expert Logic Builder.

Example: 1-channel variant

Drive	Connection	Expected status	Displayed status
1.1	2-channel	Off / 0	
1.2	2-channel	Off / 0	
2	1-channel	On / 1	
3	2-channel	Off / 0	

This table is used as an example for the documentation and it is mandatory for it to be filled out. In the column "Displayed status" the result, readable in EcoStruxure Machine Expert Logic Builder, has to be entered.

Step	Action
7	Remove the 0 V connection between the Lexium 62 Power Supply and the external power supply unit (see step 4 in the following graphic).
8	Disconnect the IE_n connection (0 V) for the 2-channel drives on the safety-related switching device (see step 5 in the following graphic).
9	Connect the disconnected IE_n connection (0 V) to the external 24 V power supply unit (see step 6 in the following graphic).

Verifying the 2-channel wiring

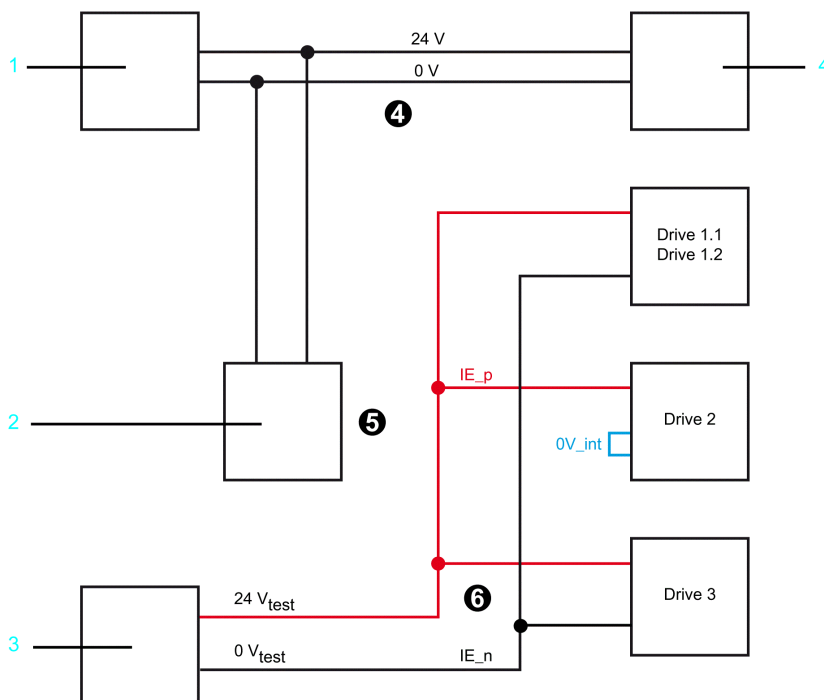

- 1 24 V power supply unit
- 2 Safety-related switching device
- 3 24 V external power supply unit
- 4 Lexium 62 Power Supply

Step	Action
1	Verify the IE (Inverter Enable) status of every individual drive in EcoStruxure Machine Expert Logic Builder. Result: In this case, only the 2-channel drives may be active.
2	Record the status values in a table. If necessary, screenshots can also be created in EcoStruxure Machine Expert Logic Builder.

Example: 2-channel variant

Drive	Connection	Expected status	Displayed status
1.1	2-channel	On / 1	
1.2	2-channel	On / 1	
2	1-channel	Off / 0	
3	2-channel	On / 1	

This table is used as an example for the documentation and it is mandatory for it to be filled out. In the column "Displayed status" the result, readable in EcoStruxure Machine Expert Logic Builder, has to be entered.

Step	Action
3	Connect the IE_n connection to the protective switching device again.
4	Connect the IE_p connection (24 V) to the protective switching device.

NOTE: The machine manufacturer must keep the tables with the documents on the machine for documentation purposes.

NOTE: Verify the wiring every time a safety-related component is replaced.

Application Proposals for Hardware Based Safety-Related Functions

Lexium 62 Variants C/D/G

The following table provides an overview of the possible application proposals for Lexium 62 variants C/D/G:

Single-channel application proposal
<ul style="list-style-type: none"> Application proposal variants C/D/G single-channel jumpered (Refer to chapter <i>Application Proposal Variants C/D/G Single-Channel Jumpered</i>, page 84.) <p>Proceed as follows to connect the variants C/D/G with single-channel Inverter Enable:</p> <ol style="list-style-type: none"> Connect 9-pin connector at the CN11 connection. Connect the 24 V of the protective switching device to IEA_p1 or IEA_p2 or IEB_p1 or IEB_p2. Connect the 24 V to the connections CN6 or CN11.
Two-channel application proposals
<ul style="list-style-type: none"> Application proposal variants C/D/G two-channel with protected wiring (Refer to chapter <i>Application Proposal Variants C/D/G Two-Channel With Protected Wiring</i>, page 85.) <p>If the lines are routed with protection, an error may be ruled out for example, control cabinet, armored conduit. Also see IEC 61800 and IEC 60204-1.</p>
<ul style="list-style-type: none"> Application proposal variants C/D/G two-channel with test pulses (Refer to chapter <i>Application Proposal Variants C/D/G Two-Channel With Test Pulses</i>, page 88.) <p>If the safety-related relay output has outputs generating, back-reading, and verifying test pulses, then an error detection is given. A protected wiring is not required.</p>
<ul style="list-style-type: none"> Application proposal variants C/D/G two-channel with external, non-safety-related diagnostic (Refer to chapter <i>Application Proposal Variants C/D/G Two-Channel With External, Non-Safety-Related Diagnostic</i>, page 89.)

Quantity of Channels and PL/SIL

The following table provides an overview of the same application proposals but from the aspect of the properties "quantity of channels" and "PL/SIL":

PL/SIL	Single-channel Inverter Enable connection	Two-channel Inverter Enable connection
PL e / SIL 3	Not possible	<ul style="list-style-type: none"> Application proposal variants C/D/G two-channel with protected wiring (Refer to chapter <i>Application Proposal Variants C/D/G Two-Channel With Protected Wiring</i>, page 85.) Application proposal variants C/D/G two-channel with test pulses (Refer to chapter <i>Application Proposal Variants C/D/G Two-Channel With Test Pulses</i>, page 88.) Application proposal variants C/D/G two-channel with external, non-safety-related diagnostic (Refer to chapter <i>Application Proposal Variants C/D/G Two-Channel With External, Non-Safety-Related Diagnostic</i>, page 89.) <p>A maximum of 100 axes per safety function.</p>
PL d / SIL 2	<ul style="list-style-type: none"> Application proposal variants C/D/G single-channel jumpered (Refer to chapter <i>Application Proposal Variants C/D/G Single-Channel Jumpered</i>, page 84.) 	<ul style="list-style-type: none"> Application proposal variants C/D/G two-channel with protected wiring (Refer to chapter <i>Application Proposal Variants C/D/G Two-Channel With Protected Wiring</i>, page 85.) Application proposal variants C/D/G two-channel with test pulses (Refer to chapter <i>Application Proposal Variants C/D/G Two-Channel With Test Pulses</i>, page 88.) Application proposal variants C/D/G two-channel with external, non-safety-related diagnostic (Refer to chapter <i>Application Proposal Variants C/D/G Two-Channel With External, Non-Safety-Related Diagnostic</i>, page 89.) <p>With more than 100 axes per safety function.</p>

Application Proposal for the Variants C/D/G Single-Channel Jumpered

Overview

Application Lexium 62 variants C/D/G single-channel jumpered

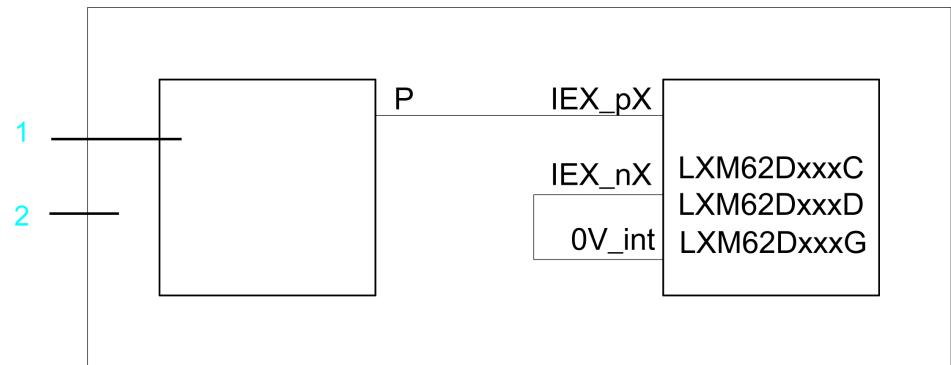

1 Safety-related switching device

2 Control cabinet

Application Proposal for the Variants C/D/G Two-Channel with Protected Wiring

Overview

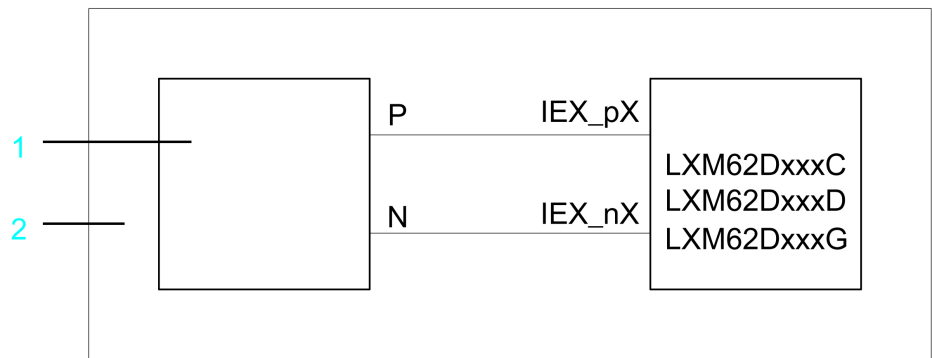

1 Safety-related switching device

2 Control cabinet

Safe Stop of Category 1 (SS1)

There is one application proposal to implement the defined safe stop of category 1 (SS1):

- APP-111011-001: Inverter Enable circuit for Logic Motion Controller Safe Stop 1 (SS1) with a protection circuit and two-channel interruption

Notes Concerning the Application Proposal - General

- The application proposal provides for a protected IEA/IEB wiring (control cabinet IP54) from the safety-related switching device to the Lexium 62, in order to help exclude potential wiring issues.
- Protection against automatic restart is provided by the external safety-related switching device.
- If potential errors cannot be ruled out, a diagnostic can optionally be provided for the two-channel variants. This must be realized externally and is not shown in the application proposal.

Notes Concerning the Application Proposal - Notes on APP-111011-001

The mains contactor K1 in this circuit proposal is not necessary for functional safety purposes. However, it is used in the application proposal for the device protection of power supplies or Lexium 62 Servo Drives.

Application proposal for the control circuit (drawing number APP-111011-001)

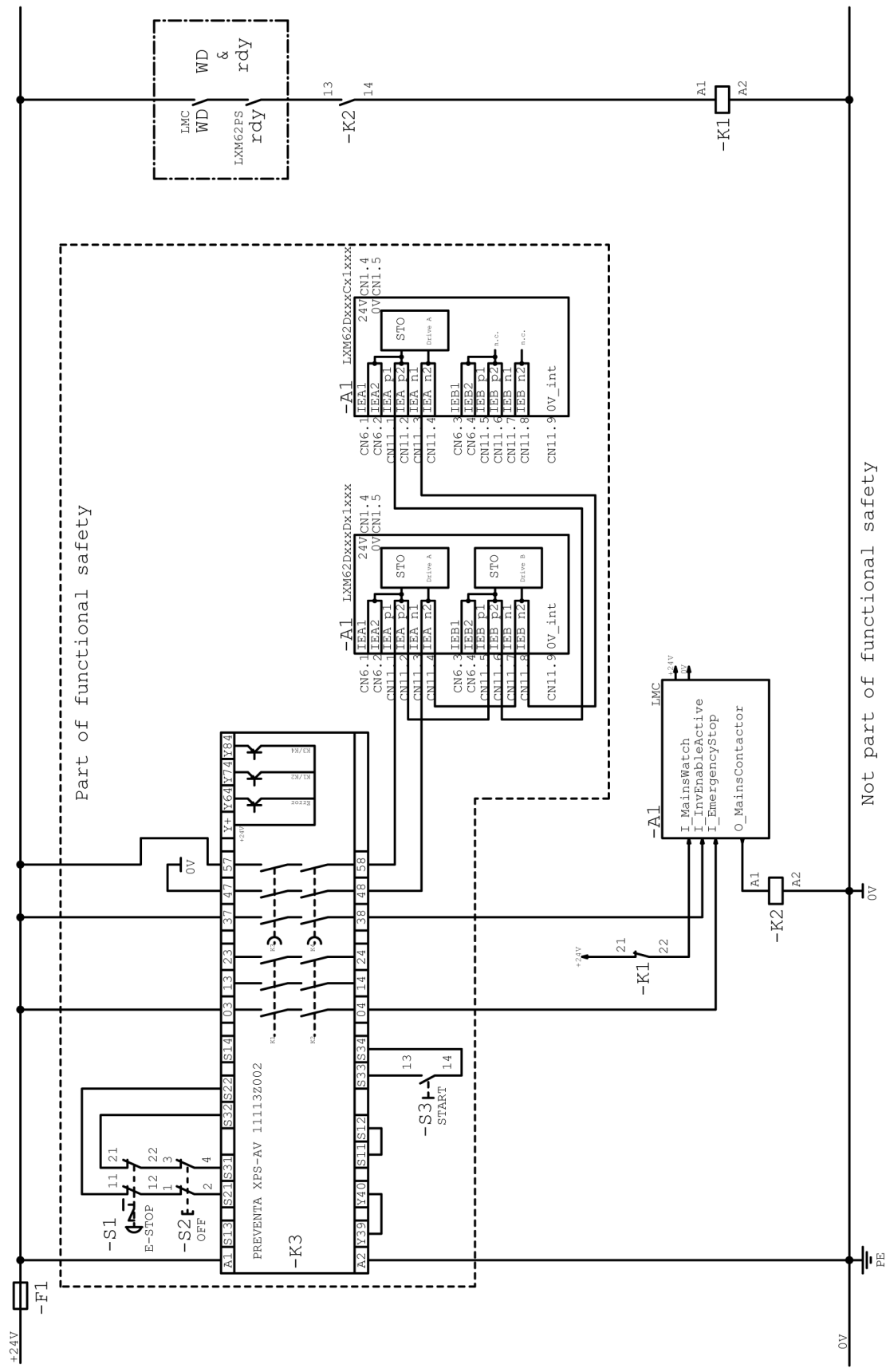

Application proposal for the load cycle (drawing number APP-111011-001)

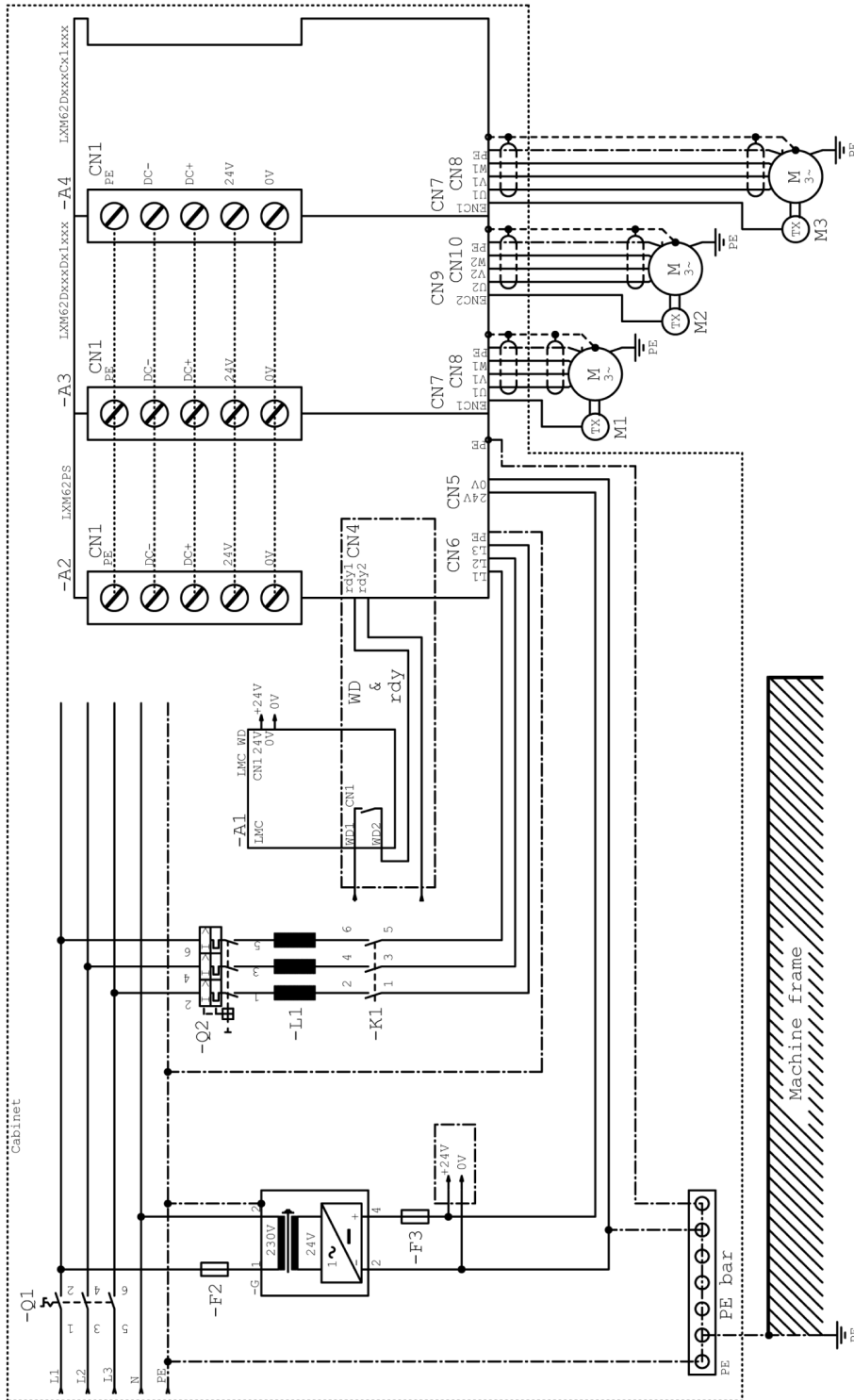

Not part of functional safety

Application Proposal for the Variants C/D/G Two-Channel with Test Pulses

Overview

Application proposal Lexium 62 variants C/D/G two-channel with test pulses

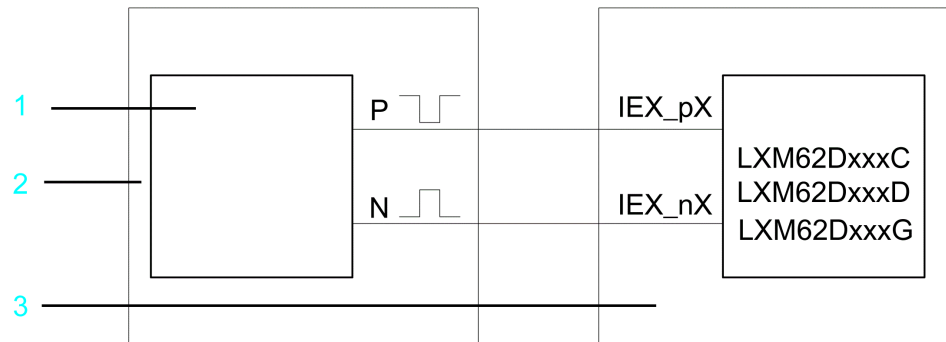

1 Safety-related switching device with pulses

2 Control cabinet 1

3 Control cabinet 2

Application Proposal for the Variants C/D/G Two-Channel with External, Non-Safety-Related Diagnostic

Overview

Application proposal Lexium 62 variants C/D/G two-channel with external, non-safety-related diagnostic (back-reading)

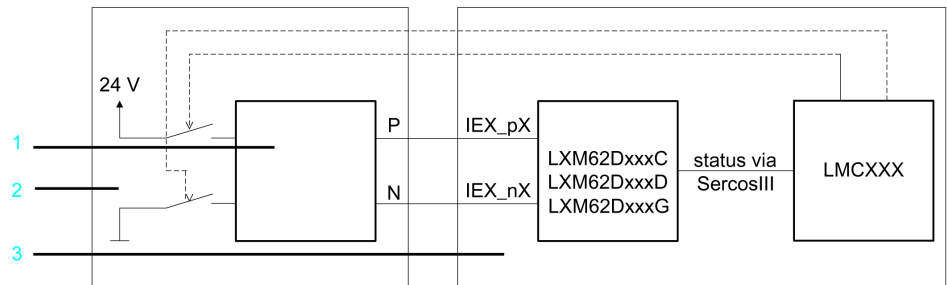

1 Safety-related switching device

2 Control cabinet 1

3 Control cabinet 2

Application Proposals for Software Based Safety-Related Function

Overview

Lexium 62 variants E/F are necessary to use software-based safety-related functions. Like Lexium 62 variants C/D/G, they also offer a dedicated two-channel input for a hardwired STO (Safe Torque Off) function.

In case the hardwired STO is not used, there is no need to connect it. In this case, the software-based safety-related functions use Sercos and OpenSAFETY, page 74.

Therefore, two application proposals are provided here for using or not using a hardwired STO function. When using the hardwired STO, the other software-based safety-related functions can be used, including the STO realized by software.

Application Proposal for the Variants E/F Using Hardwired STO

Proceed as follows to use Inverter Enable function via hardware when using Lexium 62 variants E/F:

Step	Action
1	Connect the Lexium 62 variants E/F with two-channel like the variants C/D/G, page 83.
2	Configure the safety-related network.
3	Adjust the parameters, in particular the prioritization of Inverter Enable via hardware and STO (Safe Torque Off) via the bus.
4	Program the EcoStruxure Machine Expert - Safety application.

NOTE: Observe the information on the parameters in the EcoStruxure Machine Expert - Safety online help.

Application Proposal for the Variants E/F Not Using Hardwired STO

Proceed as follows when not using Inverter Enable function via hardware but only using extended safety functions with the Lexium 62 variants E/F:

Step	Action
1	Connect the Lexium 62 variants E/F like the Lexium 62 variants C/D/G, without using CN6/CN11 — Inverter Enable connectors.
2	Configure the safety-related network.
3	Adjust the parameters, in particular the prioritization of Inverter Enable via hardware and STO (Safe Torque Off) via the bus.
4	Program the EcoStruxure Machine Expert - Safety application.

NOTE: Observe the information on the parameters in the EcoStruxure Machine Expert - Safety online help.

Application Proposal Wiring for the Control Circuit Using Hardwired STO (CN11)

Drawing number APP-111011-001, valid for Lexium 62 variants C/D/E/F/G:

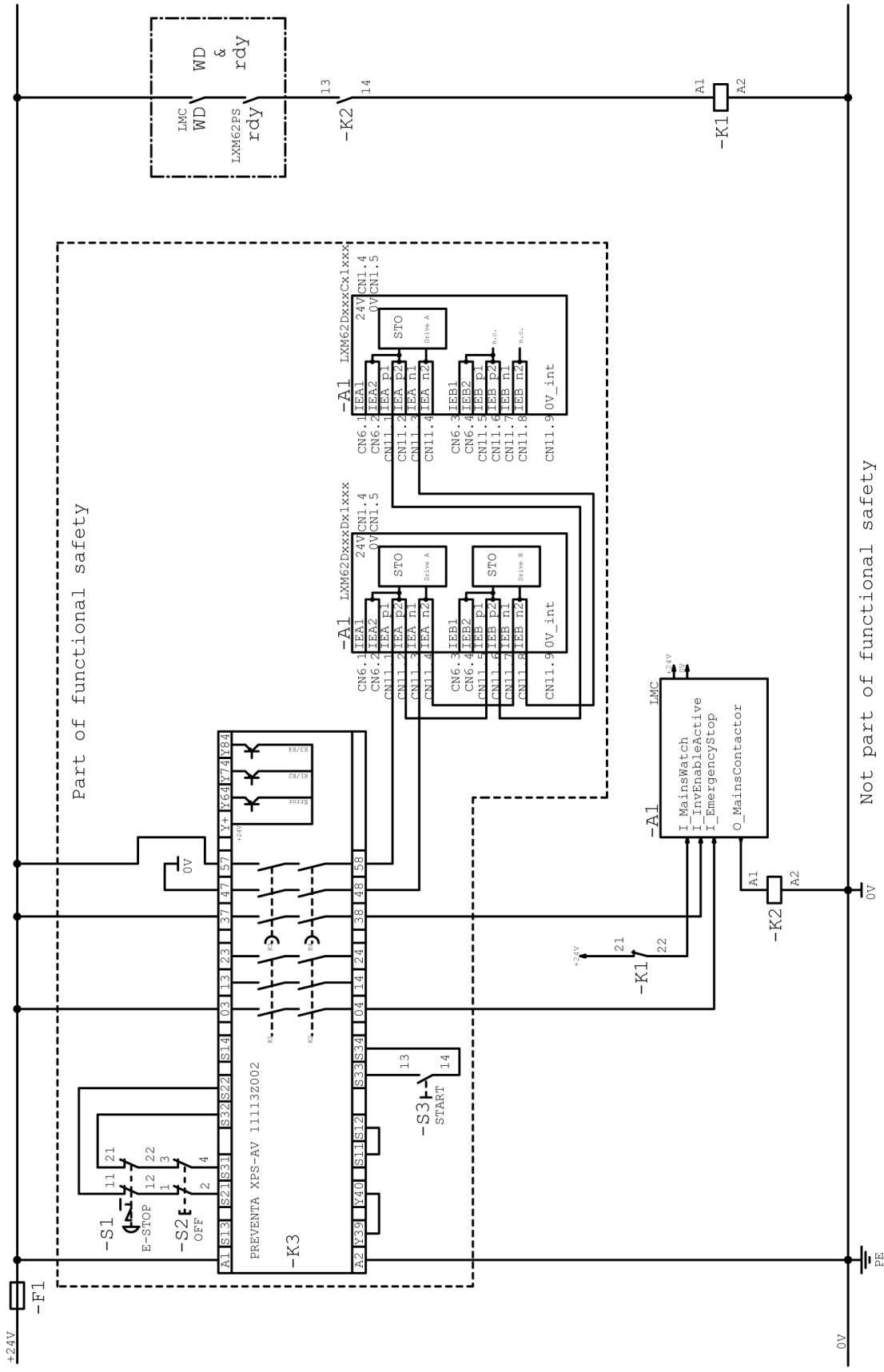

For the software-based safety-related functions use Sercos and OpenSAFETY, page 74.

Application Proposal for the Load Cycle

Drawing number APP-111011-001:

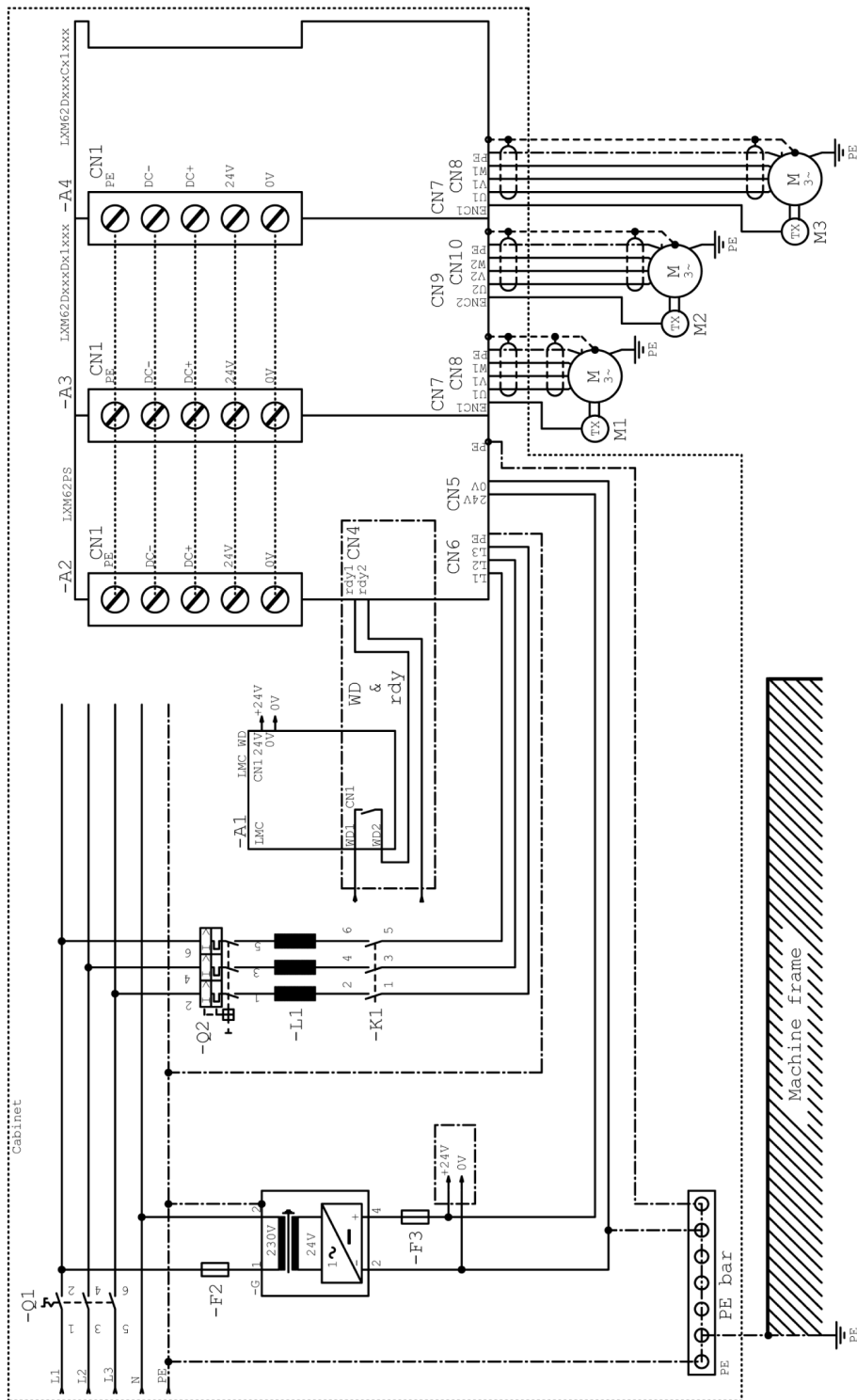

Not part of functional safety

Commissioning

General

Step	Action
1	Carry out a functional test of the STO function for all drives that need the safety function.
2	Especially verify the correct application of the axes without Inverter Enable function.
3	Complete installation in accordance with the EMC regulations and further specifications in the device operating manuals.
4	Afterwards, commission the drive systems.

NOTE: When using the extended safety functions, the Lexium 62 variants E/F must be configured, parameterized, and programmed according to the EcoStruxure Machine Expert online help and the EcoStruxure Machine Expert - Safety online help.

Best Practices

General

At machine start-up, the connected drives are usually hidden from sight of the machine operator and cannot be monitored directly.

⚠ WARNING

UNSUPERVISED MACHINE START-UP

Only start the machine if there are no persons within the zone of operation of moving machine components.

Failure to follow these instructions can result in death, serious injury, or equipment damage.

Verify Connections

Step	Action
1	Verify all terminals, connectors, and other connections on all system components for correct and firm fit.
2	Only use robust connectors and secure fixings.
3	Verify the protective earth ground (24 Vdc PELV (Protective Extra Low Voltage) supply).
4	Verify the wiring of the safety function to the axes to avoid an interchange of the IEA and IEB inputs as well as the 24 V supply.
5	Use coded connectors (refer to chapter <i>Information about Wiring</i> , page 40) and perform a commissioning test (refer to chapter <i>Commissioning</i> , page 93).
6	Use only appropriate transport packaging to forward or return individual devices.

⚠ DANGER

ELECTRIC SHOCK DUE TO INADEQUATE PROTECTIVE SEPARATION

Only connect devices, electrical components, or lines to the signal voltage connectors of these products that feature a sufficient, protective separation from the connected circuits in accordance with the standards (IEC 61800-5-1: Adjustable speed electrical power drive systems - safety requirements).

Failure to follow these instructions will result in death or serious injury.

External Forces

The defined safe state of the motor is the torque-free output shaft. If external forces act upon the output shaft, it will not necessarily maintain its position. In any case, the motor will coast to an unassisted stop. This coast down time depends on physical properties of the components used (such as weight, torque, friction, and so on), and additional measures such as mechanical brakes may be necessary to help prevent any hazard from materializing. If the torque-free defined safe state is inappropriate for your application where external forces may move the output shaft as determined by your risk assessment, implement other external safety-related measures.

▲ WARNING**UNINTENDED EQUIPMENT OPERATION**

- Make certain that no hazards can arise for persons or material during the coast down period of the axis/machine.
- Do not enter the zone of operation during the coast down period.
- Ensure that no other persons can access the zone of operation during the coast down period.
- Use appropriate safety interlocks where personnel and/or equipment hazards exist.

Failure to follow these instructions can result in death, serious injury, or equipment damage.

Hanging and Pulling Loads**▲ WARNING****UNINTENDED AXIS MOVEMENT**

- Do not use the internal holding brake as a safety-related measure.
- Only use certified external brakes as safety-related measures.

Failure to follow these instructions can result in death, serious injury, or equipment damage.

If the suspension of hanging / pulling loads is a safety objective for the machine, then you can only achieve this objective by using an appropriate external brake as a safety-related measure.

NOTE: The drive does not provide its own safety-related output to connect an external brake to use as a safety-related measure.

Maintenance

General

The Inverter Enable function has been designed for a defined lifetime that does not require to verify the safety-related function, nor any specific maintenance requirements. After this lifetime, page 98 has elapsed, a statement about the Inverter Enable function cannot be made due to the aging of the component. If you want to ensure the functional safety after this period, you need to replace the device that includes the safety function.

NOTE: Subject the product to a complete function test after replacement.

The following applies only to the Lexium 62 variants E/F.

In addition to the LED state, data of the Safety Logger is also available in the EcoStruxure Machine Expert Logic Builder. These are provided for information only and must not be used for safety-related diagnostics.

For further information about initial start-up and maintenance, refer to the chapter *Installation and Maintenance*, page 102.

Physical Environment

General

The system is not protected against physical or chemical sources of damage by any design features, such as:

- toxic,
- explosive,
- corrosive,
- highly reactive, or
- inflammable types.

This equipment has been designed to operate outside of any hazardous location. Only install this equipment in zones known to be free of a hazardous atmosphere.

⚠ DANGER

POTENTIAL FOR EXPLOSION

Install and use this equipment in non-hazardous locations only.

Failure to follow these instructions will result in death or serious injury.

⚠ WARNING

UNINTENDED EQUIPMENT OPERATION

- Observe and conform to ambient temperatures, storage temperatures and transport temperatures of the individual components as specified in the operating manuals of the components.
- Prevent the formation of moisture during the operation, storage and transport of individual components.
- Conform to the vibration and shock requirements specified in the operating manuals for the components when operating, storing and transporting system components.

Failure to follow these instructions can result in death, serious injury, or equipment damage.

The Lexium 62 Drive System must only be installed in a control cabinet (enclosure).

The control cabinet (enclosure) must be lockable by using a key or tool.

Safety Standards

General

The designated safety functions have been designed and tested for functional safety according to the following standards:

- IEC 61508:2010
- IEC 61800-5-2:2016
- ISO 13849-1:2015
- IEC 62061:2015

An independent assessment was performed by TÜV NORD.

According to the above listed standards, the figures for the Lexium 62 for using the Inverter Enable are as follows:

Standard characteristics	Variants C/D/G (two-channel connected, maximum 100 axes)	Variants C/D/G (single-channel connected, maximum 200 axes)	Variants E/F (two-channel connected, maximum 100 axes)
SFF (IEC 61508) Safe Failure Fraction	99%	99%	99%
HFT (IEC 61508) Hardware Fault Tolerance	1	1	1
Type (IEC 61508)	A	A	B
SIL (IEC 61508) Safety Integrity Level SILCL (IEC 62061) Safety Integrity Level claim limit	3	2	3
PFH (IEC 61508) Probability of Dangerous Failures per Hour	$0.5 \cdot 10^{-9}/h$	$0.5 \cdot 10^{-9}/h$	$0.95 \cdot 10^{-9}/h$
PL (cat) (ISO 13849-1) Performance Level (Category)	e (4)	d (3)	e (4)
MTTFd (ISO 13849-1) Mean Time to Dangerous Failure	6000 years	6000 years	380 years
DC (ISO 13849-1) Diagnostic Coverage	99%	99%	99%
Lifetime	20 years	20 years	20 years
Maximum reaction time between the request and execution of the designated safety function	5 ms	5 ms	10 ms
Maximum reaction time before the detection of safety-related errors	5 ms	5 ms	10 ms
Maximum reaction time between exceeding the threshold values of extended safety functions and the initiation of substitute reactions	–	–	10 ms
<p>NOTE: The values specified are rounded individually and are therefore not a result of a conversion by for example, PFH in MTTFd or the comparative tables from ISO13849-1.</p>			

In the case of the extended safety functions that can be used with the Lexium 62 variants E/F, the threshold values to be monitored can be adjusted, for example, the limit for safe velocity for the function Safe Limited Speed (SLS). If this value is exceeded, an adjustable substitute reaction is initiated, which is the reason why the previous table includes an additional reaction time.

Additionally, for the Lexium 62 variants E/F, it must be observed that the reliability values depend on the safety functions used since for all position-dependent and velocity-dependent safety functions, the encoder has to be taken into consideration. In turn, the value depends on the encoder type used (see following table). These values are also available as SISTEMA library.

The table shows the standard characteristics for the Lexium 62 variants E/F:

Standard characteristics	Lexium 62 Variant E: MTTFd (ISO 13849-1) Mean Time to Dangerous Failure [years]	Lexium 62 Variant F: MTTFd (ISO 13849-1) Mean Time to Dangerous Failure [years]
Use of SLS, etc	–	–
... with Sick Stegmann encoder SKM36	250	180
... with Sick Stegmann encoder SKS36	250	180
... with Sick Stegmann encoder SRM50	190	125
... with Sick Stegmann encoder SRS50	200	135
... with Sick Stegmann encoder SEK34	210	145
... with Sick Stegmann encoder SEL34	200	130
... with Sick Stegmann encoder SEK37	245	175
... with Sick Stegmann encoder SEL37	245	180
... with Sick Stegmann encoder TTK70	95	50
... with Sick Stegmann encoder TTK50	80	45
... with Heidenhain encoder ECN113	165	100
... but with a separately applied encoder	320	270

For the sake of clarity, it was assumed for Lexium 62 variant F that both axes use the same encoder type. Contact your Schneider Electric representative for any other calculations.

For Lexium 62 variant F, the specified MTTFd values apply if both axes are being used within one safety function. Thus, there is an arithmetical advantage when using a double drive in a safety function compared to two single drives. If only one axis of a double drive is used in a safety function, the value specified above also has to be used.

Proceed as follows to use an encoder that is not listed in the above table:

Step	Action
1	Mount the encoder in accordance with the instructions on encoder assembly. Refer to <i>Setup, Installation and Maintenance</i> , page 78.
2	Request the MTBF value of the encoder from the encoder manufacturer.
3	In the calculation tool, enter: <ul style="list-style-type: none"> • For the series connection consisting of encoder and drive, • For the drive, the values specified in the table row but with a separately applied encoder, and • For the encoder, the MTBF value, a two-channel architecture and 99% DC.

The simplified procedure described above generally leads to conservative results. If the result does not fulfill the requirements from the risk assessment, contact your Schneider Electric representative.

Special Conditions

Increased Ambient Temperature

Lexium 62 Servo Drive

If the ambient temperature exceeds 40 °C (104 °F), then the output power of the system is reduced.

Power reduction upon a change in the ambient temperature (Lexium 62 Servo Drive)

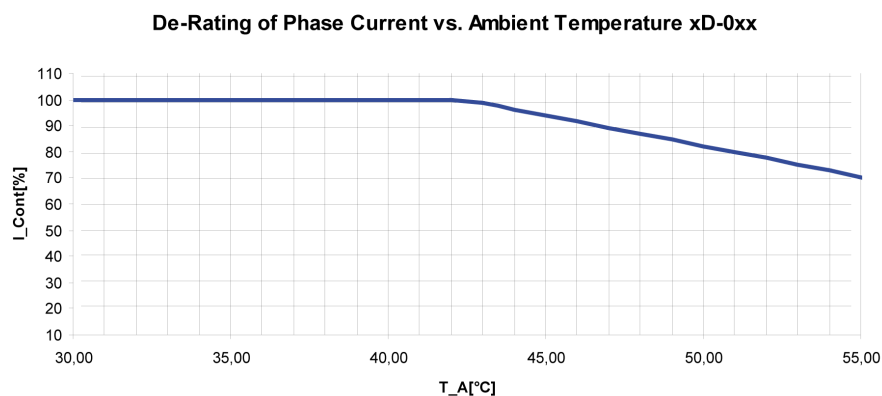

For further information on the rated and peak currents at variable ambient temperatures, refer to *Mechanical and Electrical Data - Single Drive*, page 173 and *Mechanical and Electrical Data - Double Drive*, page 178.

Lexium 62 Power Supply

Power reduction at a change of the ambient temperature (Power Supply)

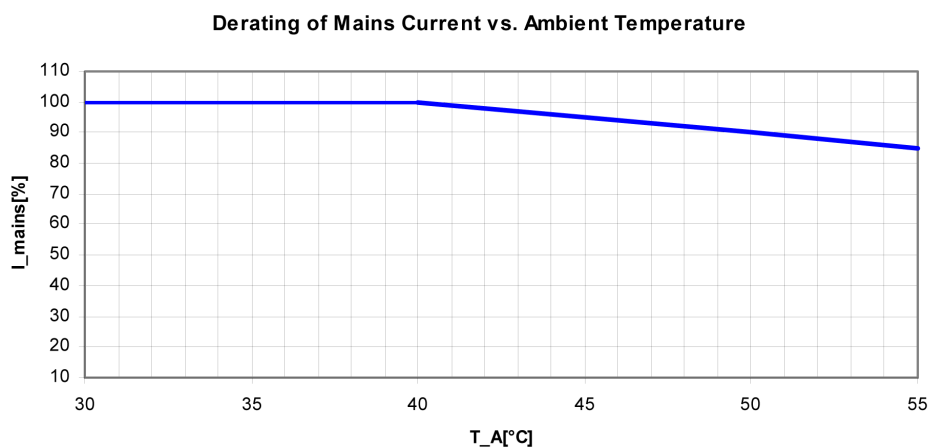

Low Air Pressure

General

If the installation altitude exceeds the specified rated installation altitude, the performance of the entire system is reduced.

Power reduction by increasing installation altitude:

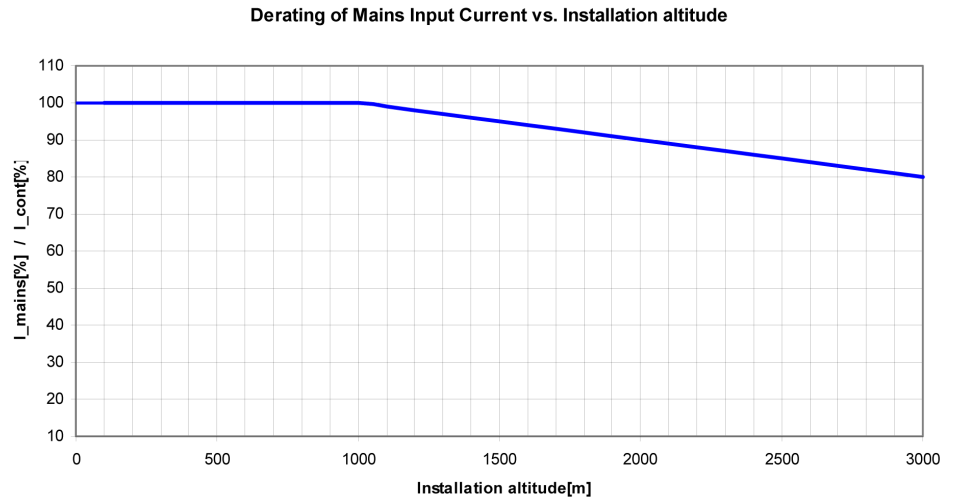

NOTE: Multiply the values with the nominal current at 40 °C (104 °F) in order to calculate the maximum continuous current value, depending on the required installation altitude.

Installation and Maintenance

Commissioning

Prerequisites for Commissioning

Prerequisites

⚠ DANGER

ELECTRIC SHOCK, EXPLOSION, OR ARC FLASH

- Disconnect all power from all equipment including connected devices prior to removing any covers or doors, or installing or removing any accessories, hardware, cables, or wires.
- Place a "Do Not Turn On" or equivalent hazard label on all power switches and lock them in the non-energized position.
- Wait 15 minutes to allow the residual energy of the DC bus capacitors to discharge.
- Measure the voltage on the DC bus with a properly rated voltage sensing device and verify that the voltage is less than 42.4 Vdc.
- Do not assume that the DC bus is voltage-free when the DC bus LED is off.
- Block the motor shaft to prevent rotation prior to performing any type of work on the drive system.
- Do not create a short-circuit across the DC bus terminals or the DC bus capacitors.
- Replace and secure all covers, accessories, hardware, cables, and wires and confirm that a proper ground connection exists before applying power to the unit.
- Use only the specified voltage when operating this equipment and any associated products.

Failure to follow these instructions will result in death or serious injury.

⚠ DANGER

ELECTRIC SHOCK, EXPLOSION, OR ARC FLASH

- Operate electrical components only with a connected protective ground (earth) cable.
- After the installation, verify the secure connection of the protective ground (earth) cable to all electrical devices to ensure that connection complies with the connection diagram.
- Before enabling the device, safely cover the live components to prevent contact.
- Do not touch the electrical connection points of the components when the module is energized.
- Provide protection against indirect contact.
- Connect and disconnect cables and terminals only after you have verified that the power has been removed from the system.
- Insulate the unused conductors on both ends of the motor cable.

Failure to follow these instructions will result in death or serious injury.

Preparing Commissioning

Prerequisite

Verify safety-related circuits for proper function, if applicable.

ESD Protection

Observe the following instructions to help avoid damages due to electrostatic discharge:

NOTICE	
ELECTROSTATIC DISCHARGE	
<ul style="list-style-type: none"> • Do not touch any of the electrical connections or components. • Prevent electrostatic charges, for example, by wearing appropriate clothing. • If you must touch circuit boards, do so only on the edges. • Remove existing static charge by touching a grounded, metallic surface. 	
Failure to follow these instructions can result in equipment damage.	

Unpacking

How to unpack the device:

Step	Action
1	Remove packaging
2	Dispose of the packaging material in accordance with the relevant local regulations.

Verifying

How to verify the device:

Step	Action
1	Verify that the delivery is complete, based on the delivery slip.
2	Closely inspect the device for any signs of damage.
3	Verify the data with the help of the nameplates.
4	Observe requirements for the installation location.
5	In addition to the following instructions, also note the information in the chapter <i>Engineering</i> , page 34.

⚠ WARNING	
UNINTENDED EQUIPMENT OPERATION	
<ul style="list-style-type: none"> • Do not mount or commission damaged drive systems. • Do not modify the drive systems. • Send back inoperative devices. 	
Failure to follow these instructions can result in death, serious injury, or equipment damage.	

Preparing the Control Cabinet

Overview

⚠ DANGER

INCORRECT OR UNAVAILABLE GROUNDING

Remove paint across a large surface at the installation points before installing the devices (bare metal connection).

Failure to follow these instructions will result in death or serious injury.

Step	Action
1	If necessary to maintain and respect the maximum ambient operating temperature, install additional fan in the control cabinet.
2	Do not block the fan air inlet of the product.
3	Drill mounting holes in the control cabinet in the 45 mm (1.77 in) mounting-grid pattern (± 0.2 mm / ± 0.01 in).
4	Observe tolerances as well as distances to the cable channels and adjacent Lexium 62 Servo Drives or other heat producing equipment.

Required Distances in the Control Cabinet for the PacDrive LMC Pro/Pro2, Lexium 62 Power Supply, Lexium 62 Servo Drive

Required distances in the control cabinet for the PacDrive LMC Pro/Pro2, Lexium 62 Power Supply, Lexium 62 Servo Drive:

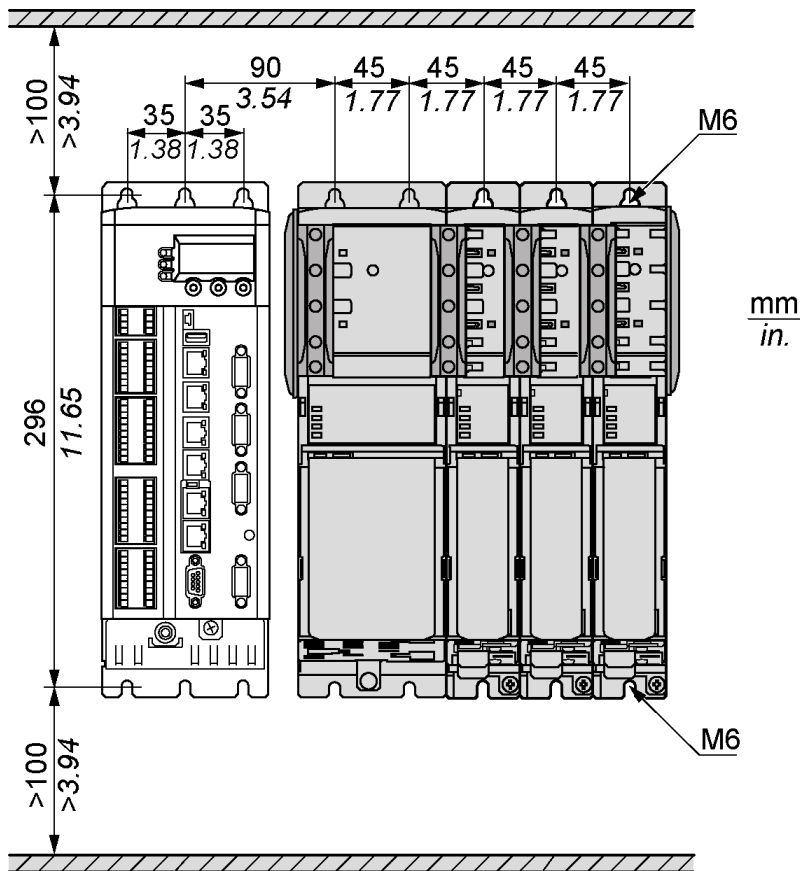

NOTE: For the shield plates (external shield connections), additional holes are required.

Required Distances in the Control Cabinet for the PacDrive LMC Eco, Lexium 62 Power Supply, Lexium 62 Servo Drive

Required distances in the control cabinet for the PacDrive LMC Eco, Lexium 62 Power Supply, Lexium 62 Servo Drive:

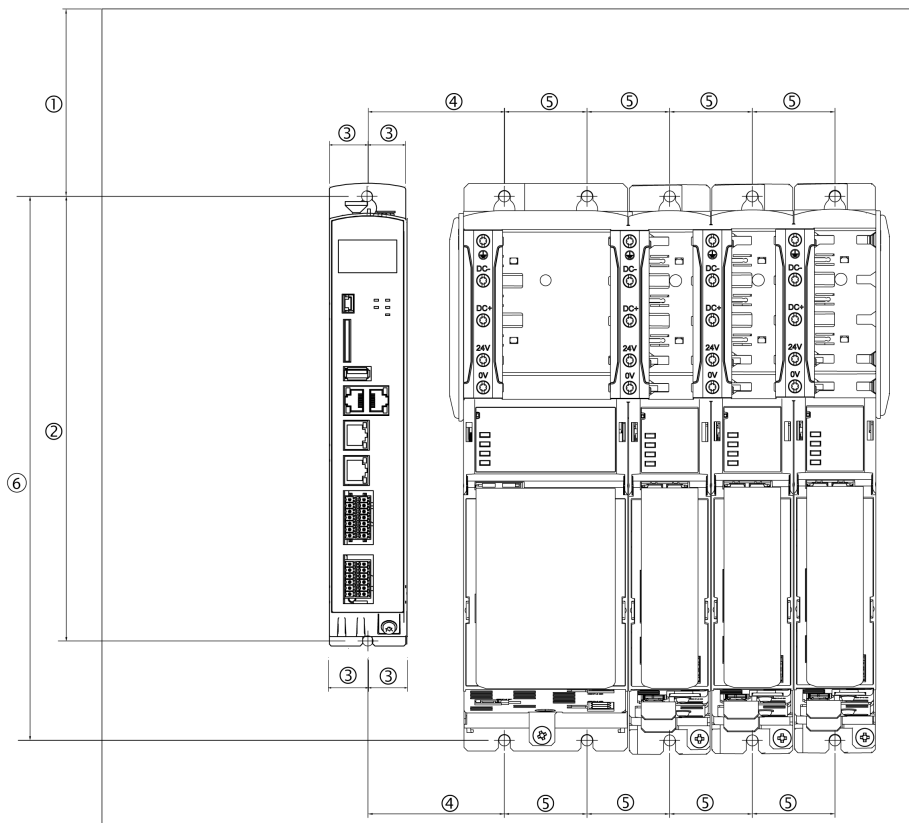

-	mm	in	Thread
(1)	100 (± 0.2)	3.94 (± 0.01)	M6
(2)	258 (+ 0.5 / -0)	10.16 (± 0.02 / -0)	M6
(3)	22 (± 0.2)	0.87 (± 0.01)	M5
(4)	55 (± 0.2)	2.17 (± 0.01)	M6
(5)	45 (± 0.2)	1.77 (± 0.01)	M6
(6)	296 (+ 0.5 / -0)	11.65 (± 0.02 / -0)	M6

NOTE: For the shield plates (external shield connections), additional holes are required.

Required Distances in the Control Cabinet for the Power Supply

- Keep a distance of at least 100 mm (3.94 in) above and below the devices.

Required distances in the control cabinet for the Lexium 62 Power Supply:

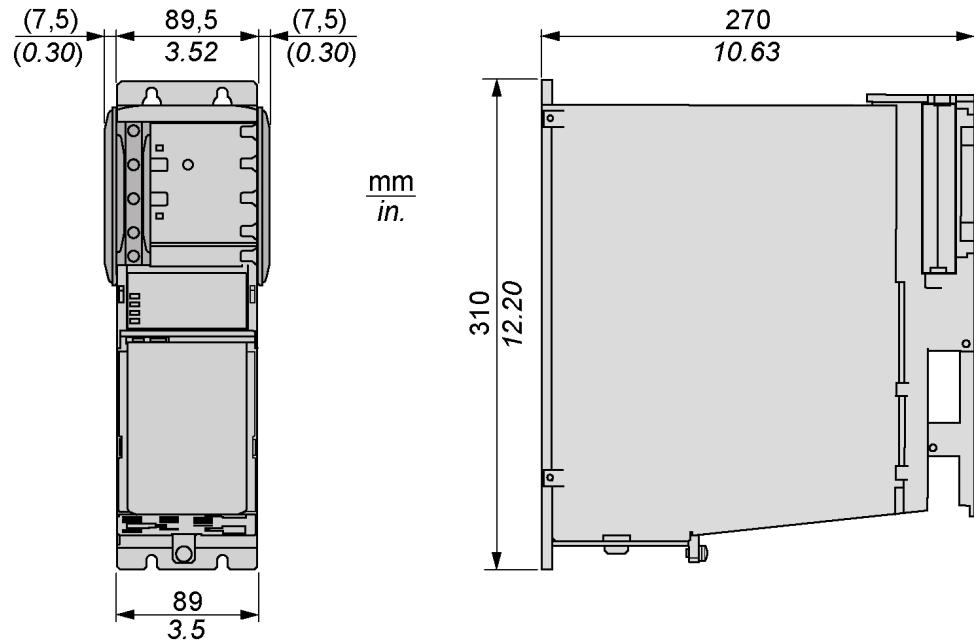

- Do not lay any cables or cable channels over the servo amplifiers or braking resistor modules.

Required Distances in the Control Cabinet for Lexium 62 Servo Drive (Excluding LXM62DC13)

Type A: cable routing in cabinet on cable tray or cable channel:

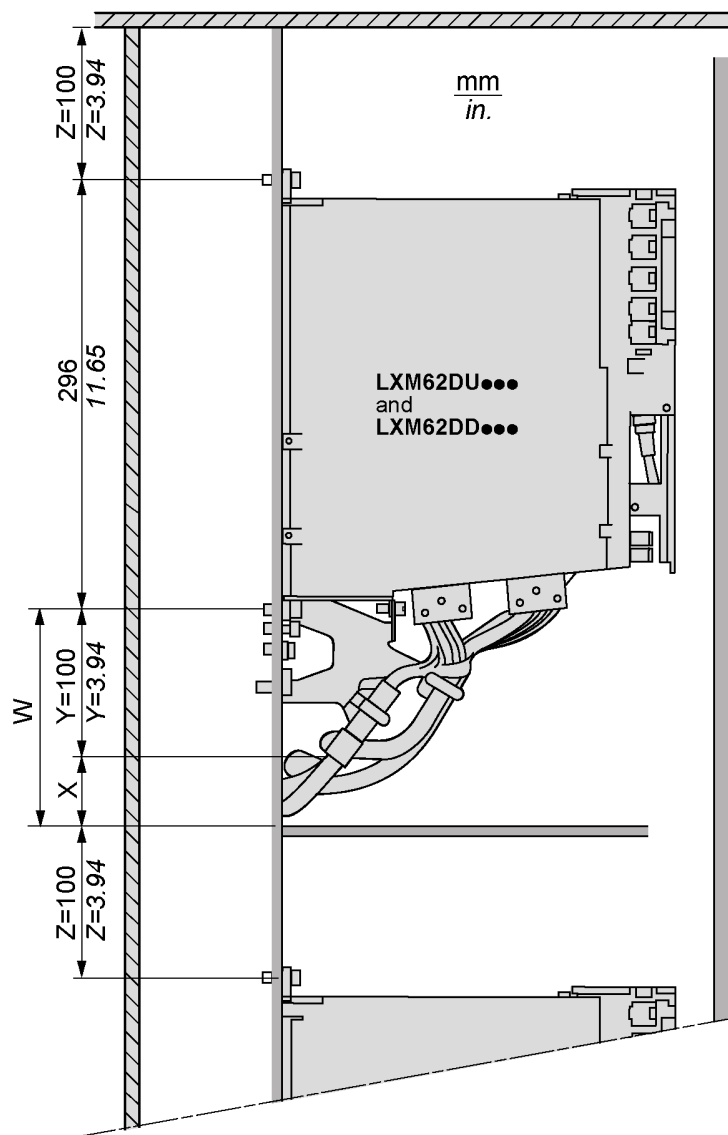

X Additional distance between the lower edge of strain relief and upper edge of cable tray or cabinet wall, depending on the diameter and number of cables

Y Minimum distance in mm (in), between device and lower edge of strain relief

Z Free area of 100 mm (3.94 in) required above device

W Minimum distance in mm (in) for cable installation (X+Y)

Type B: cable routing in cabinet behind mounting-backplane:

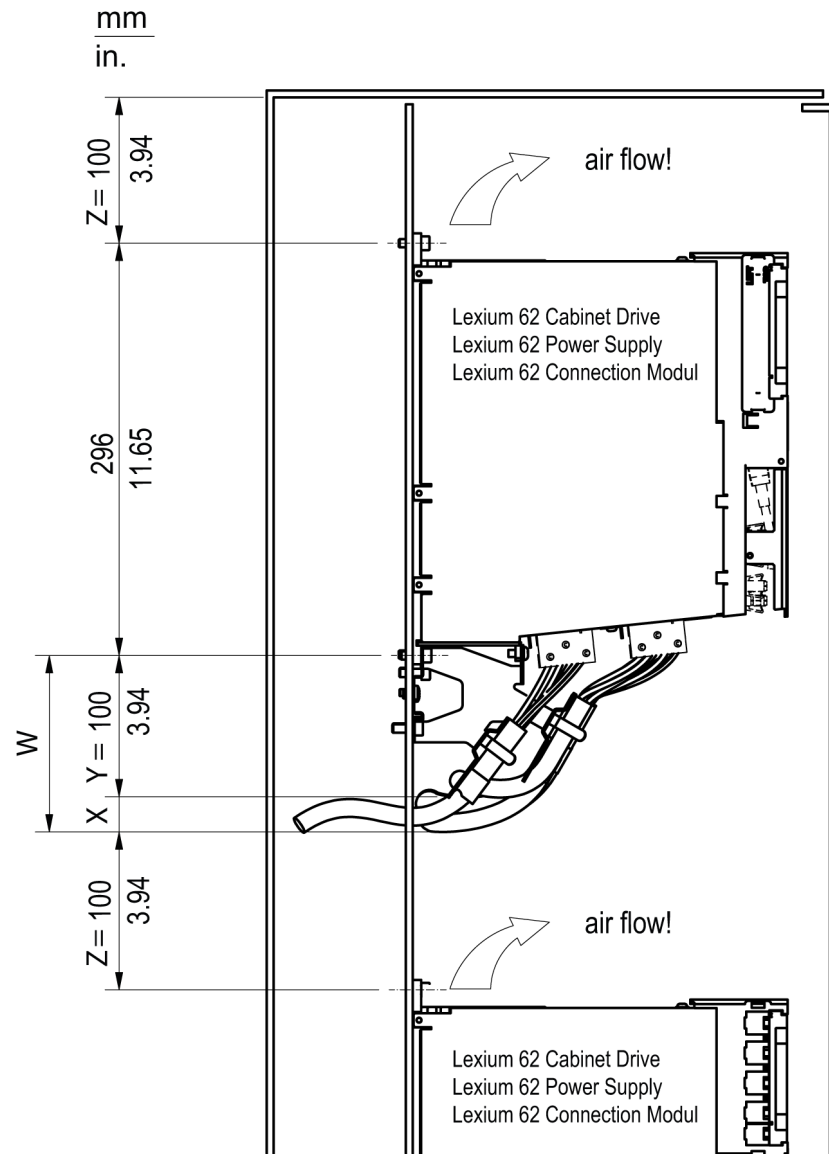

X Additional distance between the lower edge of strain relief and lower edge of cutout on backplane or cabinet wall, depending on the diameter and number of cables

Y Minimum distance in mm (in), between device and lower edge of strain relief

Z Free area of 100 mm (3.94 in) required above device

W Minimum distance in mm (in) for cable installation (X+Y)

Required Distances in the Control Cabinet for the Single Drive LXM62DC13

Step	Action
1	Keep a distance of at least 100 mm (3.94 in) above the devices.
2	Keep a distance of at least 450 mm (17.71 in) below the devices.

Required distances in the control cabinet for the single drive LXM62DC13:

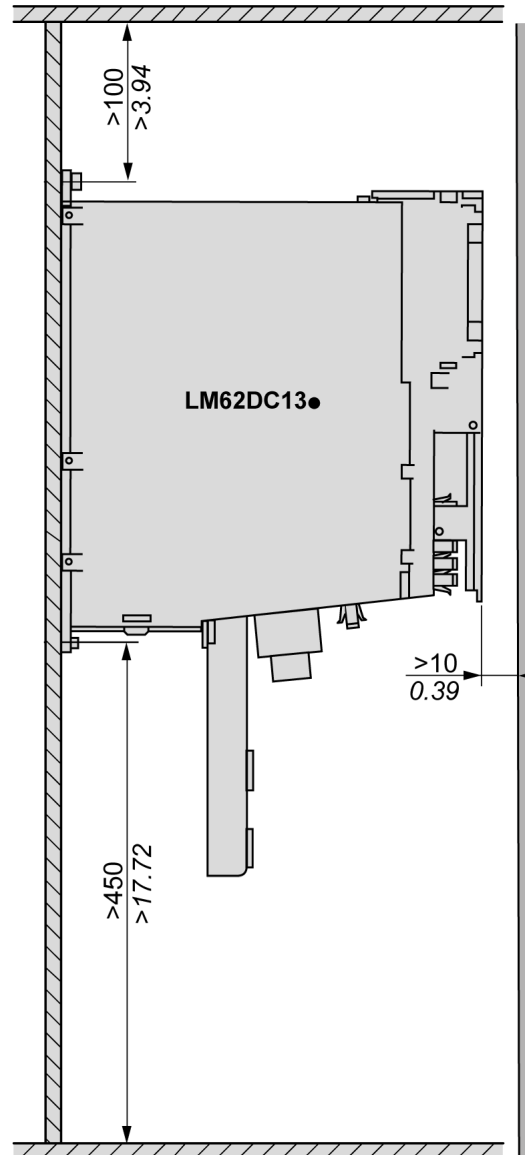

- Do not lay any cables or cable channels over the servo amplifiers or braking resistor modules.

Mounting

How to Mount the Lexium 62 Power Supply, Lexium 62 Servo Drive and Lexium 62 DC Link Support Module

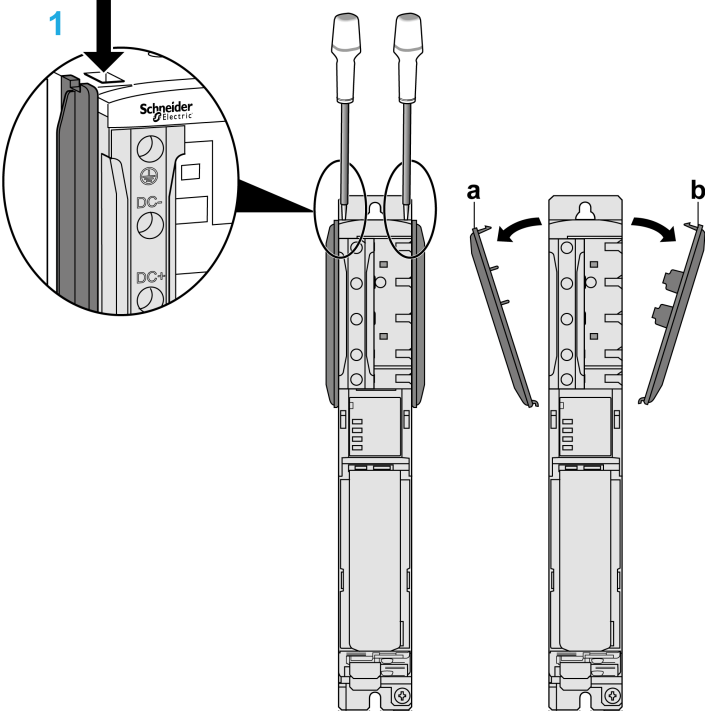
Step	Action
1	<p>Remove the terminal covers on the module sides (Lexium 62 Power Supply, Lexium 62 Servo Drive and Lexium 62 DC Link Support Module) on which the modules are connected with each other.</p> <p>For this purpose, press the screwdriver in the opening (1) (blade width: 5.5...8 mm (0.22...0.31 in)) on the top side of the module to loosen the terminal cover.</p> 
2	Then remove the terminal covers (a,b) toward the outside.
3	Screw the pan-head screws M6 (socket head cap screws) into the prepared mounting holes.
4	Keep a distance of 10 mm (0.39 in) between the screw head and the mounting plate.
5	Hook in device and verify the vertical mounting arrangement.
6	<p>If using Lexium 62 DC Link Support Module, then place it on the left or the right end of the row of Lexium 62 devices.</p> <p>Place the Power Supply and the Drive Modules in the following order from left to right according to the current carrying capacity:</p> <ol style="list-style-type: none"> 1. Power Supply 2. Drive modules according to their power, starting with the greatest. <p>NOTE: By doing this, the load on the DC bus- and 24 V-supply at the wiring bus is reduced.</p>
7	Tighten the mounting screws (torque: 4.6 Nm (41 lbf in)).

How to Assemble the Modules

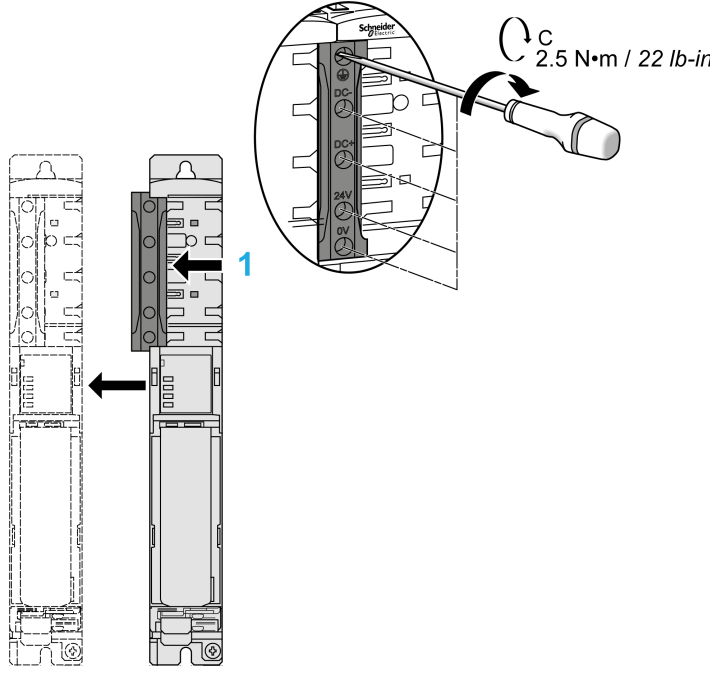
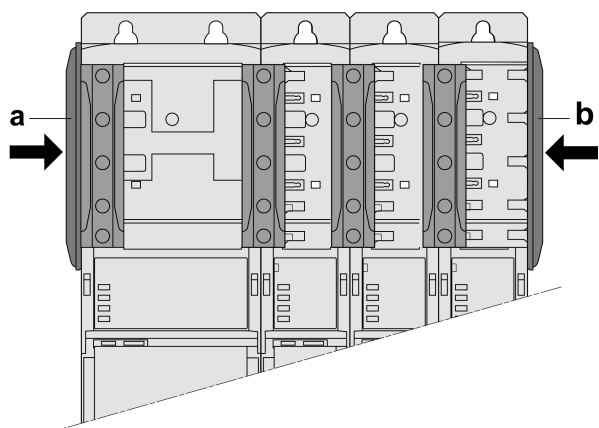
Step	Action
1	Verify whether the slide on the Bus Bar Module can be moved easily. If not, loosen the screws securing the slide to the Bus Bar Module.
2	<p>Connect devices via the slide of the Bus Bar Module (1).</p> 
3	Tighten the screws of the Bus Bar Module (torque: 2.5 Nm / 22 lbf in).
4	<p>Mount the terminal covers left TOP (a) and right TOP (b) on the outside of the Bus Bar Module combination. For important safety information, follow the instructions in the safety message after this table.</p> <p>Shock terminal covers on the outside of the Bus Bar Module combination</p> 

This product has a touch current greater than 3.5 mA. If the protective earth ground connection is interrupted, a hazardous touch current may flow if the housing is touched.

⚠ DANGER

ELECTRIC SHOCK CAUSED BY HIGH LEAKAGE (TOUCH) VOLTAGE

- Attach the terminal covers on the extremities of the *Bus Bar Module combination*, page 110.
- Apply power to the device only if the terminal covers have been attached to the extremities of the Bus Bar Module combination.

Failure to follow these instructions will result in death or serious injury.

How to Ground the Lexium 62 Power Supply

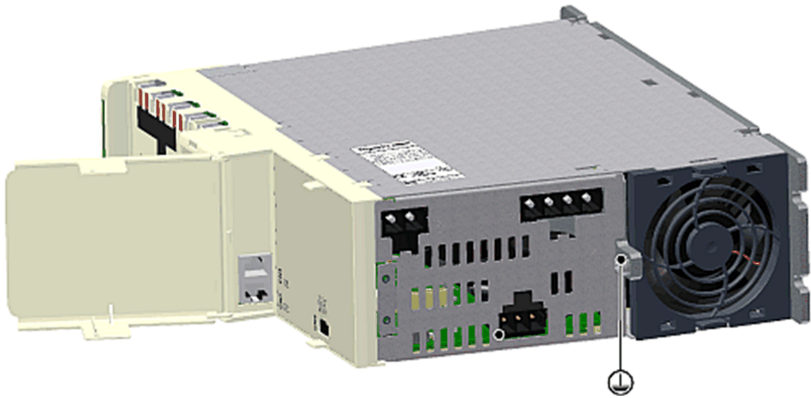
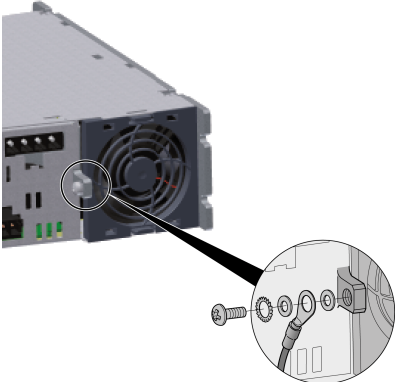
Step	Action
1	 <p>Connect the additional protective earth ground conductor with the ring cable lug and the M5 screw to the heat sink of the power supply (tightening torque: 3.5 Nm (31 lbf in)).</p>
2	 <p>Follow the assembly based on the heat sink:</p> <ul style="list-style-type: none"> • Washer • Ring cable lug • Washer • Lock washer • Screw
3	<p>Connect the plug-in connector CN5 24 V supply to the power supply.</p> <p>NOTE: See important hazard message after the table.</p>
4	<p>Connect the plug-in connector CN6 AC supply to the power supply.</p>
5	<p>Connect the Sercos cable CN2 (CN3) to the power supply.</p>

⚠ DANGER

INSUFFICIENT GROUNDING

- Use a protective ground copper conductor with at least 10 mm² (AWG 6) or two protective ground copper conductors with the same or larger cross section of the conductors supplying the power terminals.
- Verify compliance with all local and national electrical code requirements as well as all other applicable regulations with respect to grounding of all equipment.

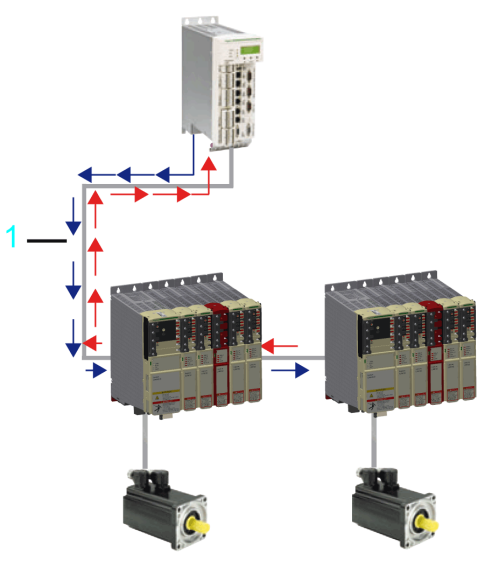
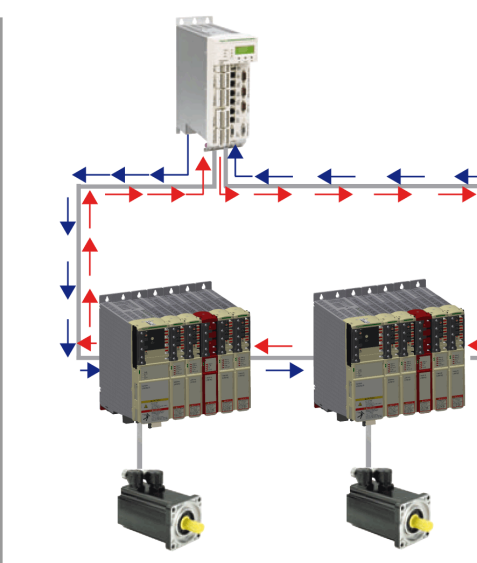

Failure to follow these instructions will result in death or serious injury.

How to Connect the Modules

Step	Action
1	<p>Insert the Sercos cable CN2 (CN3) into the drive module.</p> <p>NOTE: Depending on the device combination, choose the appropriate Sercos cable length, page 117.</p> <p>NOTE: If possible, establish a Sercos connection via the ring topology (2).</p> <p>NOTE: If Sercos devices are assigned via the topological addresses (IdentificationMode = TopologyAddress) to the PacDrive LMC, then consider the following:</p> <ul style="list-style-type: none"> • Connect your Sercos device to the PacDrive LMC either completely via Sercos port 1 (PacDrive LMC Eco: CN5, PacDrive LMC Pro/Pro2: CN12) in line topology or in ring topology using Sercos port 1 and 2 (PacDrive LMC Eco: CN5/CN6, PacDrive LMC Pro/Pro2: CN12/CN13). • Do not connect the Sercos devices to the PacDrive LMC via double line topology (PacDrive LMC Eco: CN5/CN6, PacDrive LMC Pro/Pro2: CN12/CN13). • Do not connect the Sercos devices to the PacDrive LMC only via Sercos port 2 (PacDrive LMC Eco: CN6, PacDrive LMC Pro/Pro2: CN13). <p>Line topology and ring topology</p> <div style="display: flex; justify-content: space-around; align-items: center;">   </div> <p>1 Line topology 2 Ring topology</p>
2	Connect the plug-in connector CN4 "Ready relay output" to the power supply.
3	Connect the plug-in connector CN6 / CN11 "Inverter Enable" to the drive module (Lexium 62 Servo Drive).
4	Optionally, connect the plug-in connector CN4 "IO" to the drive module.
5	Optionally, connect the plug-in connector CN5 "IO voltage supply" to the drive module.
6	Connect the "Motor connector Axis A" CN8 to the drive module.
7	<ul style="list-style-type: none"> • Connect the "Motor connector Axis B" CN10 to the double drive, if available. • Connect the "Machine Encoder Output" CN12 to the advanced double drive, if available.
8	Connect the "Encoder plug-in Axis A" CN7 to the drive module.
9	Connect the "Encoder plug-in Axis B or Machine Encoder" CN9 to the double drive, if available.
10	Connect the "Encoder output plug" CN12 to the advanced drive, if available.

How to Assemble the Lexium 62 DC Link Terminal

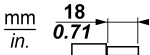
To assemble the optional Lexium 62 DC Link Terminal, proceed as follows:

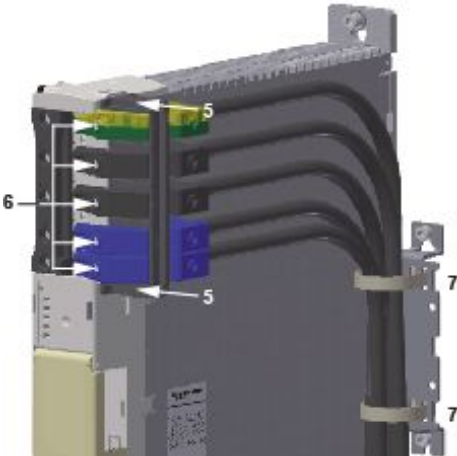
Step	Action
1	<p>Mount the strain relief, page 125 (1) to the control cabinet wall using two M5 screws.</p> 
2	 <p>Remove insulation of wires and apply cable end (without insulating sleeve) to flexible wires, page 166.</p>
3	<p>Insert the protective earth ground wire into the green/yellow terminal (2) and tighten the clamping screw (3) (torque: 4.5 Nm / 39.8 lbf in).</p> 
4	<p>Insert the other 4 wires (DC- and DC+ wires to the black terminals, 24 V, and 0 V wires to the blue terminals) and tighten the clamping screws (torque: 4.5 Nm / 39.8 lbf in).</p> <p>NOTE: The terminals are not connected to the Bus Bar Module yet.</p> <p>For important safety information, follow the instructions in the safety messages after this table.</p>
5	<p>Plug in the terminals with the wires to the Bus Bar Module connectors in the correct order (top to bottom). (4).</p> 
6	<p>Clip on the retaining bracket (5) to the Bus Bar Module.</p>  <p>NOTE: The retaining bracket is securely seated when you hear it click.</p> <p>Result: The terminals are secured against twisting.</p>

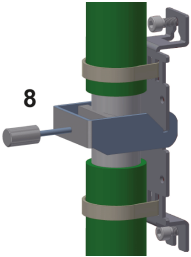
Step	Action
7	Tighten the screws of the terminals (6 in the graphic presented in step 6) on the Bus Bar Module (torque: 2.5 Nm / 22 lbf in).
8	Secure the five wires on the strain relief by using cable ties (7 in the graphic presented in step 6). NOTE: If using single-core wires within one cabinet, you must conform to the following wiring rules: <ul style="list-style-type: none"> • The solid-core DC- and DC+ wires must be installed side-by-side and must be attached to each other (for example, by cable ties). • The solid-core 24 V and 0 V wires must be installed side-by-side.
9	Optionally: If you couple two control cabinets, ground the cable shield by using the strain relief in combination with a shield connection terminal block (8) (Icotec SKS 20-35 or Phoenix Contact SK35). NOTE: A shield connection terminal block can be used for cables with diameters between 20 mm (0.79 in) and 35 mm (1.37 in). 

⚠ ⚠ DANGER

FIRE, ELECTRIC SHOCK, OR ARC FLASH WHEN USING LEXIUM 62 DC LINK TERMINAL

- Thoroughly verify the proper isolation of DC-/DC+ to PE (Protective Earth/ground) with an appropriate measuring instrument before first power on.
- Verify that the terminals are fully inserted on the Bus Bar Module.
- Do not connect DC+ to PE, 24 Vdc, 0 V or to DC-.
- Do not connect DC- to PE, 24 Vdc, 0 V or to DC+.
- Install the bus terminal connectors in the correct order 1 to 5 as follows: PE (1, green/yellow), DC- (2, black), DC+ (3, black), +24 V (4, blue), and 0 V (5, blue).
- Always install the full complement of the five connectors and the retaining bracket of the Lexium 62 DC Link Terminal.
- Always wire at least the PE, DC- and DC+ terminals out of the 5 installed connectors.
- Verify that the PE (Protective Earth/ground) terminal (1, green/yellow) is always connected to protective ground (earth) using a conductor of at least 10 mm² (AWG 6).
- Verify compliance with all local and national electrical code requirements as well as all other applicable regulations with respect to grounding of all equipment.
- Do not insert more than one wire per terminal.
- Tighten clamping screws of the terminals in conformance with the torque specifications.
- Only use the cable conductors with the appropriate cross-sections and current carrying capacities.
- Only use wires of appropriate cross-section as indicated, page 166.

Failure to follow these instructions will result in death or serious injury.

⚠ DANGER**ELECTRIC SHOCK**

- Only use stranded wires with appropriate cable ends or rigid wire.
- Use only cable ends without an insulating sleeve.
- Thoroughly verify that the cable ends, page 166 are fitted correctly such that the wire is secure and no wire strands are exposed.
- Mark the wires to prevent incorrect connections.

Failure to follow these instructions will result in death or serious injury.

⚡⚠ DANGER**ELECTRIC SHOCK**

- Mount the retaining bracket as instructed in the product documentation.
- Ensure that the retaining bracket is fixed securely to the bus bar module.
- Do not remove the retaining bracket or the terminals while the product is energized.

Failure to follow these instructions will result in death or serious injury.

⚡⚠ DANGER**ELECTRIC SHOCK**

- Ensure that the cable ties are securely holding the wires/cables on the strain relief component.
- Ensure that all forces acting on the terminals and connected wires/cables are minimized.

Failure to follow these instructions will result in death or serious injury.

⚡⚠ DANGER**IMPROPER WIRING BETWEEN CONTROL CABINETS CAUSES ELECTRIC SHOCK**

- Only use appropriate and certified cables according to the applicable standards.
- Only use the cables with the appropriate cross-sections.
- Do not use individual wires outside the control cabinet; use cables only.
- Observe the bending radius of the cable/wire specification of the manufacturer.
- Thoroughly verify the cables/wires for defects and/or damages after the installation.
- Use cable ducts and other appropriate measures outside of the control cabinet protecting the cables/wires from damage and mechanical stress.
- Remove insulation accurately according to the stripping length of the cable conductor.

Failure to follow these instructions will result in death or serious injury.

⚠ DANGER

FIRE HAZARD

- Do not exceed an overall cable length of 3 m (9.84 ft) between any row without Lexium 62 DC Link Support Module or Lexium 62 Power Supply module and the next row with a Lexium 62 Power Supply module or Lexium 62 DC Link Support Module.
- Install a Lexium 62 DC Link Support Module for each drive of type LXM62DC13 in rows without Lexium 62 Power Supply module.
- Install all Lexium 62 Power Supply modules with linked DC Bus in the same control cabinet sharing the same mains contactor.

Failure to follow these instructions will result in death or serious injury.

⚠ WARNING

HIGH ELECTROMAGNETIC RADIATION

- Do not exceed a cable length of 15 m (49.2 ft) for single connections using Lexium 62 DC Link Terminal.
- Do not exceed an overall cable length of 50 meters (164 ft) between one Lexium 62 device and any other Lexium 62 device connected via a Lexium 62 DC Link Terminal.

Failure to follow these instructions can result in death, serious injury, or equipment damage.

Device Combination and Sercos Cable Length

The table shows the Sercos cable length to wire of the Sercos communication for each device combination:

Connection	Device left side	Device right side	Sercos cable length
CN2 / CN3	LXM62PD20 / LXM62PD84	LXM62PD20 / LXM62PD84	130 mm (5.11 in)
CN2 / CN3	LXM62PD20 / LXM62PD84	LXM62DD / LXM62DU	130 mm (5.11 in)
CN2 / CN3	LXM62PD20 / LXM62PD84	LXM62DC13C / LXM62DC13E	150 mm (5.90 in)
CN2 / CN3	LXM62DC13C / LXM62DC13E	LXM62DC13C / LXM62DC13E	130 mm (5.11 in)
CN2 / CN3	LXM62DC13C / LXM62DC13E	LXM62PD20 / LXM62PD84	115 mm (4.52 in)
CN2 / CN3	LXM62DC13C / LXM62DC13E	LXM62DD / LXM62DU	115 mm (4.52 in)
CN2 / CN3	LXM62DD / LXM62DU	LXM62DD / LXM62DU	90 mm (3.54 in)
CN2 / CN3	LXM62DD / LXM62DU	LXM62PD20 / LXM62PD84	90 mm (3.54 in)
CN2 / CN3	LXM62DD / LXM62DU	LXM62DC13C / LXM62DC13E	115 mm (4.52 in)

External Shield Connection on the Drive Module (Excluding LXM62DC13)

Presentation

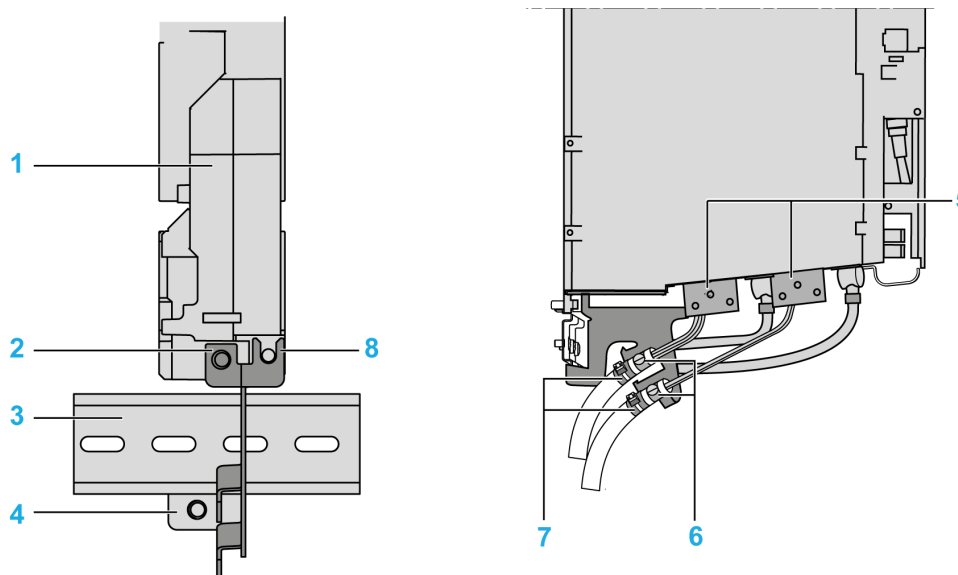

- 1 Drive module (Lexium 62 Servo Drive)
- 2 Mounting holes of the drive module
- 3 Cap rail
- 4 Position of the lower hole for mounting the shield plate
- 5 Motor connectors
- 6 Braided shield of the cable in spring clip
- 7 Strain relief by using cable ties (Encoder cable can be fixed at this place)
- 8 Mounting points on the drive module

With Cap Rail

Step	Action
1	Drill holes for mounting the cap rail (3) 29.5 mm (1.16 in.) below the lower mounting hole (2) (M6) of the drive module (1).
2	Mount the cap rail.
3	Clamp the shield plate below the cap rail. Then screw down the shield plate into the hole (2) and on the drive (8).
4	When mounting the shield plate by using the cap rail, an additional hole (4) is not required.
5	Afterwards, establish the shield connection of the motor cable. For this, press the braided shield of the prefabricated cable into the spring clip (6).
6	Provide for strain relief (7) by using cable ties.

Without Cap Rail

Step	Action
1	Starting from the lower mounting hole (M6) of the drive module, move 52.5 mm (2.07 in.) down and 8.5 mm (0.33 in.) to the left and drill an M6 threaded hole (4).
2	Screw the shield plate into the three mounting points (2), (4) and (8).
3	Afterwards, establish the shield connection of the motor cable. For this, press the braided shield of the prefabricated cable into the spring clip (6).
4	Provide for strain relief (7) by using cable ties.

NOTE: The external shield plate complete with cable ties is included in the accessory kit CSD-1.

External Shield Connection on the Drive Module (Excluding LXM62DC13) Former Shield Plate

Presentation

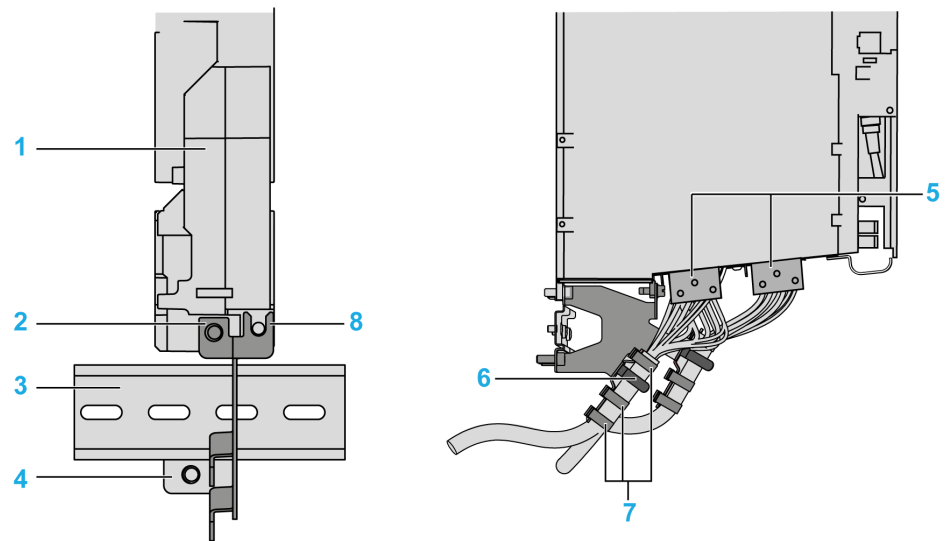

- 1 Drive module (Lexium 62 Servo Drive)
- 2 Mounting holes of the drive module
- 3 Cap rail
- 4 Position of the lower hole for mounting the shield plate
- 5 Motor connectors
- 6 Braided shield of the cable in spring clip
- 7 Strain relief by using cable ties (Encoder cable can be fixed at this place)
- 8 Mounting points on the drive module

With Cap Rail

Step	Action
1	Drill holes for mounting the cap rail (3) 29.5 mm (1.16 in.) below the lower mounting hole (2) (M6) of the drive module (1).
2	Mount the cap rail.
3	Clamp the shield plate below the cap rail. Then screw down the shield plate into the hole (2) and on the drive (8).
4	When mounting the shield plate by using the cap rail, an additional hole (4) is not required.
5	Afterwards, establish the shield connection of the motor cable. For this, press the braided shield of the prefabricated cable into the spring clip (6).
6	Provide for strain relief (7) by using cable ties.

Without Cap Rail

Step	Action
1	Starting from the lower mounting hole (M6) of the drive module, move 52.5 mm (2.07 in.) down and 8.5 mm (0.33 in.) to the left and drill an M6 threaded hole (4).
2	Screw the shield plate into the three mounting points (2), (4) and (8).
3	Afterwards, establish the shield connection of the motor cable. For this, press the braided shield of the prefabricated cable into the spring clip (6).
4	Provide for strain relief (7) by using cable ties.

NOTE: The external shield plate complete with cable ties is included in the accessory kit CSD-1.

External Shield Connection on the Drive Module LXM62DC13

Presentation

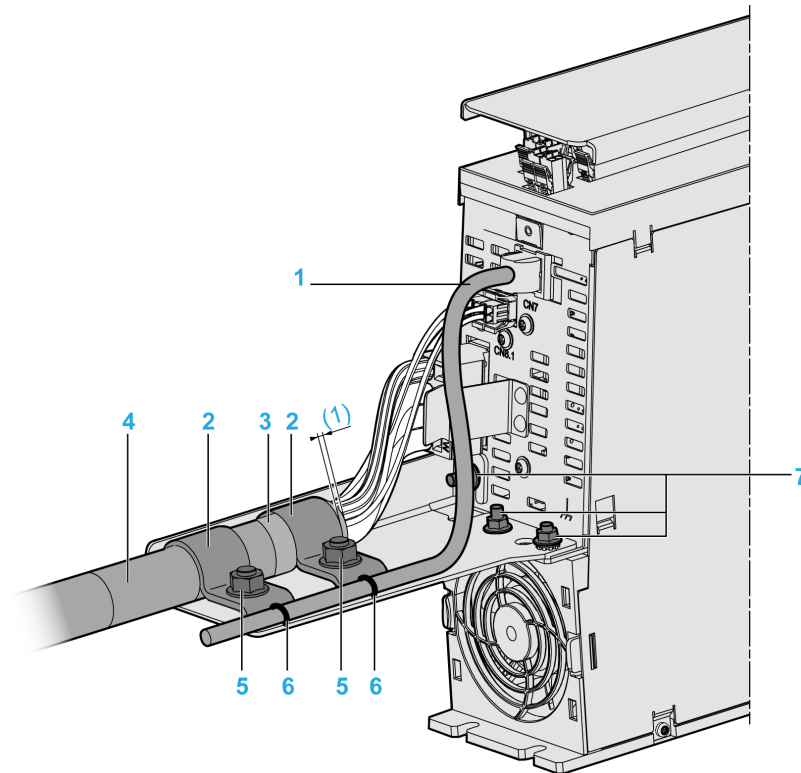

- 1 Encoder cables
- 2 Ground clamp
- 3 Braided shield of cable
- 4 Motor cables
- 5 Bolt on the shield plate
- 6 Strain relief via cable ties
- 7 Bolt on drive module
- (1) Braided shield protrusion (at least 5 mm/0.2 in)

Procedure

To mount the shield plate and to attach the motor/encoder cable, proceed as follows:

Step	Action
1	Release and remove the screw-nuts M5 on the bolts (7).
2	Fix the shield plate on the bottom side of the drive module, so that the bolts (7) are in the corresponding holes of the shielding.
3	Tighten the bolts (7) on the shield plate with the screw nuts M5 (tightening torque: 2.5 Nm / 22 lbf in).
4	Connect the motor supply cable (4) to the shield plate so that the end of the cable sheathing is located in the range of the bolt (5).
5	Place both ground clamps (2) over the cable sheathing so that the bolts (5) are located in the holes of the ground clamps. <ul style="list-style-type: none"> Use the larger ground clamps ESE23 for motor supply cables with a cable cross section of 10 mm². Use the smaller ground clamps ESE19 for motor supply cables with a cable cross section of 4 mm².
6	Loosely fix the motor supply cable with both screw-nuts M8 above the two ground clamps (2). Result: The motor supply cable can still be moved underneath the ground clamps.
7	Finally position the motor supply cable, so that the cable sheathing has a protrusion F to the ground clamp (2) of at least 5 mm (0.2 in.) and the braided shield of the cable (3) is positioned below the first ground clamp (2).
8	Tighten the motor supply cable with both screw nuts M8 above the two ground clamps (2) (tightening torque: 6 Nm / 53.10 lbf in).
9	Connect the encoder cable (1) to the shield plate and relief the strain by using cable ties (6).

NOTE: The external shield plate including the ground clamps, M5/M8 screw-nuts and the cable ties are included in the accessory kit "CSD-Kit-LXM62DC13SD".

Strain Relief for Lexium 62 DC Link Terminal Connections

Overview

When using heavy gauge wires, a strain relief is necessary in order to help reduce the mechanical forces resulting from heavy cables acting on the Lexium 62 DC Link Terminal. The strain relief is supplied with the Lexium 62 DC Link Terminal.

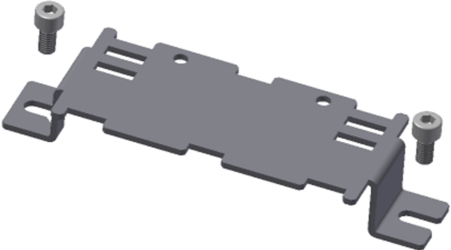
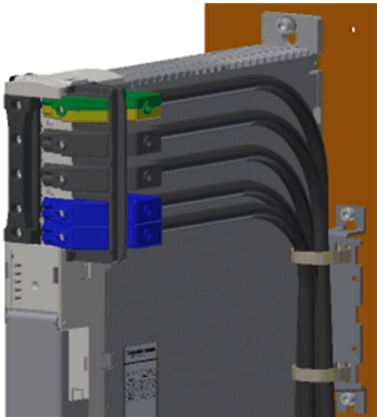
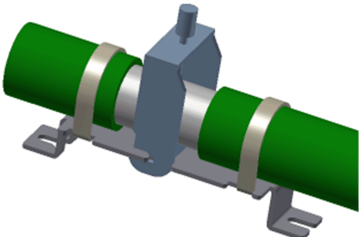
<p>Strain relief to be mounted to the control cabinet wall, which is supplied with Lexium 62 DC Link Terminal.</p>	
<p>Strain relief without optional shield connection terminal block.</p>	
<p>Strain relief with optional shield connection for cables with diameters between 20 mm (0.79 in.) and 35 mm (1.37 in.).</p>	

Mounting the Strain Relief in the Control Cabinet

Two holes are necessary to mount the strain relief in the control cabinet:

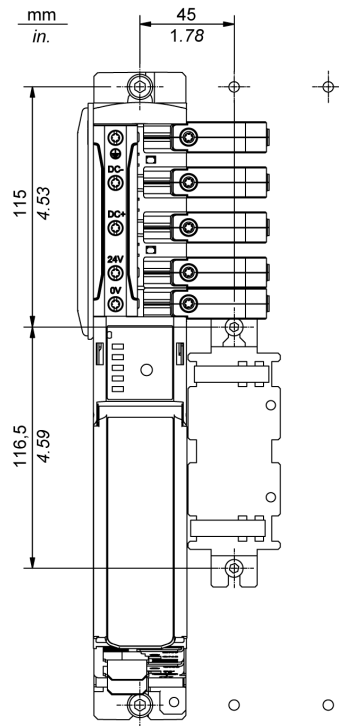

To mount the strain relief for the Lexium 62 DC Link Terminal, proceed as follows:

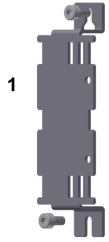
Step	Action
1	<p>Mount the strain relief (1) to the control cabinet wall using two M5 screws.</p>  <p>Optionally you can mount it on a cap rail.</p>
2	Secure the wires/cables by using cable ties.

⚠️ DANGER

ELECTRIC SHOCK

- Ensure that the cable ties are securely holding the wires/cables on the strain relief component.
- Ensure that all forces acting on the terminals and connected wires/cables are minimized.

Failure to follow these instructions will result in death or serious injury.

Grounding the Optional Shield Connection Terminal Block

The shield connection terminal block allows you to connect the cable shield electrically conducting to PE (Protective Earth/ground) by using the strain relief screwed on the rear wall of the control cabinet.

NOTE: Use a shielded cable for the connection of Lexium 62 device islands which are located in separate control cabinets.

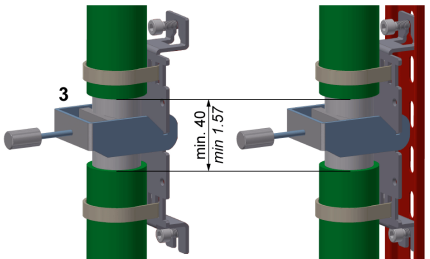
Step	Action
1	Mount the strain relief to a grounded metal surface.
2	 <p>If you use shielded cable with a cable diameter between 20 mm (0.79 in.) and 35 mm (1.37 in.), ground the cable shield by applying the strain relief with a shield connection terminal block (3). To this end, the cable sheath must be stripped for at least 40 mm (1.57 in.) to clamp the cable shield.</p>

Maintenance, Repair, Cleaning, Replacement Equipment Inventory

Prerequisites for Maintenance, Repair, and Cleaning

Introduction

Observe the following instructions before carrying out maintenance on the Lexium 62 Drive System.

De-Energize the System

⚠ DANGER

ELECTRIC SHOCK, EXPLOSION, OR ARC FLASH

- Disconnect all power from all equipment including connected devices prior to removing any covers or doors, or installing or removing any accessories, hardware, cables, or wires.
- Place a "Do Not Turn On" or equivalent hazard label on all power switches and lock them in the non-energized position.
- Wait 15 minutes to allow the residual energy of the DC bus capacitors to discharge.
- Measure the voltage on the DC bus with a properly rated voltage sensing device and verify that the voltage is less than 42.4 Vdc.
- Do not assume that the DC bus is voltage-free when the DC bus LED is off.
- Block the motor shaft to prevent rotation prior to performing any type of work on the drive system.
- Do not create a short-circuit across the DC bus terminals or the DC bus capacitors.
- Replace and secure all covers, accessories, hardware, cables, and wires and confirm that a proper ground connection exists before applying power to the unit.
- Use only the specified voltage when operating this equipment and any associated products.

Failure to follow these instructions will result in death or serious injury.

How to de-energize the system:

Step	Action
1	Set main switch to OFF position, or otherwise disconnect all power to the system.
2	Prevent main switch from being switched back on.
3	In the case of any drives, servos or other equipment with high capacity capacitors, wait at least 15 minutes after removing power (switching off) to allow the DC bus capacitors to discharge.
4	Verify whether the DC-BUS LED indicator has turned off on all components located in the axis group.
5	Verify with an appropriate measuring instrument that the voltages between DC+ to PE (Protective Earth/ground), DC- to PE and DC+ to DC- are all less than 42.4 Vdc.

⚠ DANGER**ELECTRIC SHOCK, EXPLOSION OR ARC FLASH**

Verify with a correctly calibrated measuring instrument that the DC bus is de-energized (less than 42.4 Vdc) before replacing, maintaining or cleaning machine components.

Failure to follow these instructions will result in death or serious injury.

For further information on the DC Bus LED indicator, refer to *Bus Bar Module LED Indicators on the Lexium 62 Power Supply and Lexium 62 Servo Drive*, page 146.

Machine Repair

Presentation

When replacing Lexium 62 components, be sure to observe the important safety information in the sections of the present document concerning mounting and dismantling components.

⚠ DANGER

ELECTRIC SHOCK CAUSED BY HIGH LEAKAGE (TOUCH) VOLTAGE

- Before working on the product, make sure that it is de-energized.
- After disconnection, do not touch connector CN6 mains connection on the Lexium 62 Power Supply module as it still carries hazardous voltages for approximately one second.
- Only operate the Lexium 62 components in a control cabinet that cannot be opened without the help of tools.

Failure to follow these instructions will result in death or serious injury.

There are no user-serviceable parts within the Lexium 62 components. Either replace the entire drive or contact your Schneider Electric representative.

⚠ WARNING

UNINTENDED EQUIPMENT OPERATION

- Only use software and hardware components approved by Schneider Electric for use with this equipment.
- Do not attempt to service this equipment outside of authorized Schneider Electric service centers.
- Update your application program every time you change the physical hardware configuration.

Failure to follow these instructions can result in death, serious injury, or equipment damage.

Use only the accessories and mounting parts specified in the documentation and no third-party devices or components that have not been expressly approved by Schneider Electric. Do not modify the equipment.

In case machine repair includes the replacement of the drive components, observe the following instructions for ESD protection in order to avoid any damage due to electrostatic discharge:

NOTICE

ELECTROSTATIC DISCHARGE

- Do not touch any of the electrical connections or components.
- Prevent electrostatic charges, for example, by wearing appropriate clothing.
- If you must touch circuit boards, do so only on the edges.
- Remove existing static charge by touching a grounded, metallic surface.

Failure to follow these instructions can result in equipment damage.

Cleaning

Cleaning the Lexium 62 Drive

Care must be taken with cleaning products as some active agents may have deleterious effects on plastics and stainless steel welds.

NOTICE

CORROSION CAUSED BY CLEANING AGENTS

- Before using a cleaning agent, carry out a compatibility test in relation to the cleaning agent and the component affected.
- Do not use alkaline detergent.
- Do not use any chlorid-containing cleaning agents.
- Do not use any sulphuric acid containing detergent.

Failure to follow these instructions can result in equipment damage.

For further information on the material properties of your component, refer to *Technical Data*, page 167.

Replacement Equipment Inventory

Presentation

Keep a stock of the most important components to make certain your machine is functioning and ready for operation.

Replace devices with the same hardware configuration to help ensure compatibility.

Indicate the following information on the replacement equipment order:

- Drive reference: for example, LXM62DD15D
- Hardware revision: for example, **RS 01**

<i>NOTICE</i>
INCREASED PULSE ENERGY ABSORPTION CAPACITY OF THE LEXIUM 62 POWER SUPPLY MODULE
Only replace Lexium 62 power supply module with the same or greater version.
Failure to follow these instructions can result in equipment damage.

This information can be found on the nameplates.

For further information on the replacement of components, refer to *Replacing Components and Cables*, page 132.

NOTE: For software and hardware compatibility information, refer to *Compatibility of Lexium 62 Drives and Programming Software Versions* (see EcoStruxure Machine Expert Compatibility and Migration, User Guide).

Replacing Components and Cables

Prerequisites for Replacing Components and Cables

De-Energize the System

⚠ DANGER

ELECTRIC SHOCK, EXPLOSION, OR ARC FLASH

- Disconnect all power from all equipment including connected devices prior to removing any covers or doors, or installing or removing any accessories, hardware, cables, or wires.
- Place a "Do Not Turn On" or equivalent hazard label on all power switches and lock them in the non-energized position.
- Wait 15 minutes to allow the residual energy of the DC bus capacitors to discharge.
- Measure the voltage on the DC bus with a properly rated voltage sensing device and verify that the voltage is less than 42.4 Vdc.
- Do not assume that the DC bus is voltage-free when the DC bus LED is off.
- Block the motor shaft to prevent rotation prior to performing any type of work on the drive system.
- Do not create a short-circuit across the DC bus terminals or the DC bus capacitors.
- Replace and secure all covers, accessories, hardware, cables, and wires and confirm that a proper ground connection exists before applying power to the unit.
- Use only the specified voltage when operating this equipment and any associated products.

Failure to follow these instructions will result in death or serious injury.

How to de-energize the system:

Step	Action
1	Set main switch to OFF position, or otherwise disconnect all power to the system.
2	Prevent main switch from being switched back on.
3	In the case of any drives, servos or other equipment with high capacity capacitors, wait at least 15 minutes after removing power (switching off) to allow the DC bus capacitors to discharge.
4	Verify whether the DC-BUS LED indicator has turned off on all components located in the axis group.
5	Verify with an appropriate measuring instrument that the voltages between DC+ to PE (Protective Earth/ground), DC- to PE and DC+ to DC- are all less than 42.4 Vdc.

⚠ DANGER

ELECTRIC SHOCK, EXPLOSION OR ARC FLASH

Verify with a correctly calibrated measuring instrument that the DC bus is de-energized (less than 42.4 Vdc) before replacing, maintaining or cleaning machine components.

Failure to follow these instructions will result in death or serious injury.

For further information on the DC Bus LED indicator, refer to *Bus Bar Module LED Indicators on the Lexium 62 Power Supply and Lexium 62 Servo Drive*, page 146.

Other Prerequisites

⚠ DANGER

ELECTRIC SHOCK, EXPLOSION, OR ARC FLASH

- Operate electrical components only with a connected protective ground (earth) cable.
- After the installation, verify the secure connection of the protective ground (earth) cable to all electrical devices to ensure that connection complies with the connection diagram.
- Before enabling the device, safely cover the live components to prevent contact.
- Do not touch the electrical connection points of the components when the module is energized.
- Provide protection against indirect contact.
- Connect and disconnect cables and terminals only after you have verified that the power has been removed from the system.
- Insulate the unused conductors on both ends of the motor cable.

Failure to follow these instructions will result in death or serious injury.

There are no user-serviceable parts within the Lexium 62 components. Either replace the entire drive or contact your Schneider Electric representative.

⚠ WARNING

UNINTENDED EQUIPMENT OPERATION

- Only use software and hardware components approved by Schneider Electric for use with this equipment.
- Do not attempt to service this equipment outside of authorized Schneider Electric service centers.
- Update your application program every time you change the physical hardware configuration.

Failure to follow these instructions can result in death, serious injury, or equipment damage.

⚠ WARNING

IMPROPER REPLACEMENT OR OPENING OF THE COMPONENT HOUSING

- Do not open the housing of the components for commissioning, replacement, or any other reason whatsoever unless otherwise instructed in the specific product documentation of the component.
- Observe and respect the instructions and specifications contained in the product documentation and that of the machine manufacturer when replacing components.
- Replace inoperable components as a whole.

Failure to follow these instructions can result in death, serious injury, or equipment damage.

The metal surfaces of the product may exceed 65 °C (149 °F) (for bare metal) during operation.

▲ WARNING

HOT SURFACES

- Avoid unprotected contact with hot surfaces.
- Do not allow flammable or heat-sensitive parts in the immediate vicinity of hot surfaces.
- Verify that the heat dissipation is sufficient by performing a test run under maximum load conditions.

Failure to follow these instructions can result in death, serious injury, or equipment damage.

Component Replacement

How to Replace a Lexium 62 Drive System Component

Before beginning the replacement of specific components, read thoroughly the *Prerequisites for Replacing Components and Cables*, page 132 for important safety information.

⚠ DANGER

ELECTRIC SHOCK, EXPLOSION, OR ARC FLASH

- Disconnect all power from all equipment including connected devices prior to removing any covers or doors, or installing or removing any accessories, hardware, cables, or wires.
- Place a "Do Not Turn On" or equivalent hazard label on all power switches and lock them in the non-energized position.
- Wait 15 minutes to allow the residual energy of the DC bus capacitors to discharge.
- Measure the voltage on the DC bus with a properly rated voltage sensing device and verify that the voltage is less than 42.4 Vdc.
- Do not assume that the DC bus is voltage-free when the DC bus LED is off.
- Block the motor shaft to prevent rotation prior to performing any type of work on the drive system.
- Do not create a short-circuit across the DC bus terminals or the DC bus capacitors.
- Replace and secure all covers, accessories, hardware, cables, and wires and confirm that a proper ground connection exists before applying power to the unit.
- Use only the specified voltage when operating this equipment and any associated products.

Failure to follow these instructions will result in death or serious injury.

⚠ DANGER

INOPERABLE SAFETY FUNCTION

Test the proper functioning of the safety functions after every device replacement and every change of the wiring.

Failure to follow these instructions will result in death or serious injury.

Step	Action
1	Disconnect all connection cables on the device that shall be replaced.
2	Loosen the screwed connections on the wiring bus (CN1) of the component that shall be replaced.
3	If present, loosen the screwed connections of the adjacent device on the right-hand side.
4	Push both slides (CN1) to the right.
5	Respectively undo screwed connections to the device mounting on the device rear wall (heat sink) at the top end and bottom end. For important safety information, follow the instructions in the safety messages after this table.
6	If a Lexium 62 DC Link Terminal is present, loosen the screwed connections of the component.
7	Remove the Lexium 62 component and replace it.
8	Install the new Lexium 62 component and tighten the screwed connections on the top and bottom side.
9	Verify whether the terminal cover is attached to the wiring bus (CN1) at the end of a row. For important safety information, follow the instructions in the safety messages after this table.

Step	Action
10	If present, connect the Lexium 62 DC Link Terminal to the Lexium 62 component. For important safety information and the detailed procedure, refer to <i>How to Assemble the Lexium 62 DC Link Terminal</i> , page 114.
11	Connect the Lexium 62 component according to the circuit diagram of the machine. For important safety information, follow the instructions in the safety messages after this table.
12	After replacing a Lexium 62 component, proceed as by the first commissioning. For further information, refer to <i>Commissioning</i> , page 102.

DANGER

ELECTRIC SHOCK CAUSED BY HIGH LEAKAGE (TOUCH) VOLTAGE

- Attach the terminal covers on the extremities of the *Bus Bar Module combination*, page 110.
- Apply power to the device only if the terminal covers have been attached to the extremities of the Bus Bar Module combination.

Failure to follow these instructions will result in death or serious injury.

DANGER

INCORRECT ASSIGNMENT OF CABLES

Verify that the assignment of the cables conforms to their previous connector assignments.

Failure to follow these instructions will result in death or serious injury.

DANGER

FIRE, ELECTRIC SHOCK, OR ARC FLASH WHEN USING LEXIUM 62 DC LINK TERMINAL

- Thoroughly verify the proper isolation of DC-/DC+ to PE (Protective Earth/ground) with an appropriate measuring instrument before first power on.
- Verify that the terminals are fully inserted on the Bus Bar Module.
- Do not connect DC+ to PE, 24 Vdc, 0 V or to DC-.
- Do not connect DC- to PE, 24 Vdc, 0 V or to DC+.
- Install the bus terminal connectors in the correct order 1 to 5 as follows: PE (1, green/yellow), DC- (2, black), DC+ (3, black), +24 V (4, blue), and 0 V (5, blue).
- Always install the full complement of the five connectors and the retaining bracket of the Lexium 62 DC Link Terminal.
- Always wire at least the PE, DC- and DC+ terminals out of the 5 installed connectors.
- Verify that the PE (Protective Earth/ground) terminal (1, green/yellow) is always connected to protective ground (earth) using a conductor of at least 10 mm² (AWG 6).
- Verify compliance with all local and national electrical code requirements as well as all other applicable regulations with respect to grounding of all equipment.
- Do not insert more than one wire per terminal.
- Tighten clamping screws of the terminals in conformance with the torque specifications.
- Only use the cable conductors with the appropriate cross-sections and current carrying capacities.
- Only use wires of appropriate cross-section as indicated, page 166.

Failure to follow these instructions will result in death or serious injury.

▲ CAUTION

FALLING HEAVY OBJECT

Do not fully remove the screw connections of the device mounting suspension and prevent the device from falling out and down.

Failure to follow these instructions can result in injury or equipment damage.

Cable Replacement

Introduction

NOTE: In addition to the following instructions, you must observe the specifications of the machine manufacturer when replacing the cables.

De-Energize the System

⚠ DANGER

ELECTRIC SHOCK, EXPLOSION, OR ARC FLASH

- Disconnect all power from all equipment including connected devices prior to removing any covers or doors, or installing or removing any accessories, hardware, cables, or wires.
- Place a "Do Not Turn On" or equivalent hazard label on all power switches and lock them in the non-energized position.
- Wait 15 minutes to allow the residual energy of the DC bus capacitors to discharge.
- Measure the voltage on the DC bus with a properly rated voltage sensing device and verify that the voltage is less than 42.4 Vdc.
- Do not assume that the DC bus is voltage-free when the DC bus LED is off.
- Block the motor shaft to prevent rotation prior to performing any type of work on the drive system.
- Do not create a short-circuit across the DC bus terminals or the DC bus capacitors.
- Replace and secure all covers, accessories, hardware, cables, and wires and confirm that a proper ground connection exists before applying power to the unit.
- Use only the specified voltage when operating this equipment and any associated products.

Failure to follow these instructions will result in death or serious injury.

How to de-energize the system:

Step	Action
1	Set main switch to OFF position, or otherwise disconnect all power to the system.
2	Prevent main switch from being switched back on.
3	In the case of any drives, servos or other equipment with high capacity capacitors, wait at least 15 minutes after removing power (switching off) to allow the DC bus capacitors to discharge.
4	Verify whether the DC-BUS LED indicator has turned off on all components located in the axis group.
5	Verify with an appropriate measuring instrument that the voltages between DC+ to PE (Protective Earth/ground), DC- to PE and DC+ to DC- are all less than 42.4 Vdc.

⚠ DANGER

ELECTRIC SHOCK, EXPLOSION OR ARC FLASH

Verify with a correctly calibrated measuring instrument that the DC bus is de-energized (less than 42.4 Vdc) before replacing, maintaining or cleaning machine components.

Failure to follow these instructions will result in death or serious injury.

For further information on the DC Bus LED indicator, refer to *Bus Bar Module LED Indicators on the Lexium 62 Power Supply and Lexium 62 Servo Drive*, page 146.

Procedure

Proceed as follows for cable replacement:

- Be sure that the cables clearly indicate their connections before disconnecting.
- Replace cables with an identical type and length.
- Refer to any documentation from the original machine manufacturer before replacing cables.
- Disconnect/Attach the cable from the equipment components involved.
- For cable replacement of Lexium 62 DC Link Terminal, observe the wiring instructions, page 56.

⚠ DANGER

INOPERABLE INVERTER ENABLE FUNCTION

Test the proper functioning of the Inverter Enable after every device replacement and every change of the wiring.

Failure to follow these instructions will result in death or serious injury.

⚠ DANGER

INCORRECT ASSIGNMENT OF CABLES

Verify that the assignment of the cables conforms to their previous connector assignments.

Failure to follow these instructions will result in death or serious injury.

Indicators and Control Elements

Indicators of the Lexium 62 Power Supply

Overview

The display of the Lexium 62 Power Supply consists of four LED indicators that are used to display status information.

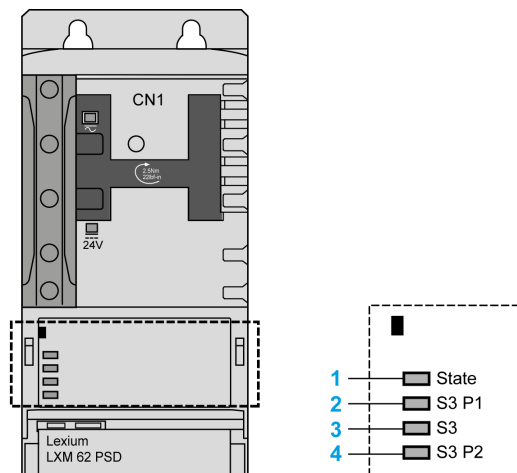

- 1 **State** LED indicator
- 2 **S3 P1** LED indicator for the status of port 1 of the Sercos III communication
- 3 **S3** LED indicator for the Sercos III communication
- 4 **S3 P2** LED indicator for the status of port 2 of the Sercos III communication

Reset Button

Press the reset button to reset and restart the Lexium 62 Power Supply.

State LED Indicator

LED indicator color / status	Description	Instructions / information for the user
Off	Device is not energized or is otherwise inoperable.	<ul style="list-style-type: none"> • Verify the power supply. • Replace device.
Flashing slowly green (2 Hz, 250 ms)	Initialization of the device (firmware boot process, compatibility verification of the hardware, updating the firmware)	<ul style="list-style-type: none"> • Wait until initialization is complete.
Flashing green (4 Hz, 125 ms)	Identification of the device	<ul style="list-style-type: none"> • If necessary, identify the device via EcoStruxure Machine Expert as defined by the controller configuration.
Steady green	Device has been initialized and waits for the configuration.	<ul style="list-style-type: none"> • Configure device as active. • Configure device as inactive. • Configure device for the execution of motions.

LED indicator color / status	Description	Instructions / information for the user
Steady red	A non-recoverable error has been detected requiring user intervention: <ul style="list-style-type: none"> • Watchdog • Firmware • Checksum • Internal error detected 	<ul style="list-style-type: none"> • Cycle power (power reset) • If this condition persists, replace the device.
Flashing slowly red (2 Hz, 250 ms)	A general error has been detected.	<ul style="list-style-type: none"> • The Devices tree in EcoStruxure Machine Expert displays the error detected. • Reset error detected in the EcoStruxure Machine Expert Logic Builder menu Online > Reset diagnostic messages of controller. • Otherwise restart device.

S3 P1 and S3 P2 LED Indicators

LED indicator color / status	Description	Instructions / information for the user
Off	Possible causes: <ul style="list-style-type: none"> • No cable connected • The device is not energized 	<ul style="list-style-type: none"> • Connect the cable. • Verify the power supply.
Steady orange	Cable connected, no Sercos communication	–
Steady green	Cable connected, active Sercos communication	–

S3 LED Indicator

LED indicator color / status	Description	Instructions / information for the user
Off	Possible causes: <ul style="list-style-type: none"> • The device is not energized or is otherwise inoperable, or • there is no communication due to an interrupted or separated connection. 	<ul style="list-style-type: none"> • Verify the power supply. • Sercos boot-up or hot swap
Steady green	Active Sercos connection without an error detected in the CP4.	–
Flashing green (4 Hz, 125 ms)	The device is in loopback mode. Loopback describes the situation in which the Sercos telegrams have to be sent back on the same port on which they were received. Possible causes: <ul style="list-style-type: none"> • Line topology or • Sercos loop break 	Workaround: <ul style="list-style-type: none"> • Close ring. Reset condition: <ul style="list-style-type: none"> • Acknowledge the detected error in the EcoStruxure Machine Expert Logic Builder menu Online > Reset diagnostic messages of controller. • Switch from CP0 to CP1 alternatively. NOTE: If during phase CP1 a line topology or ring break was detected (device in loopback mode), the LED indicator condition does not change.
Steady red	Sercos diagnostic class 1 (DC1) error has been detected on port 1 and/or port 2.	Reset condition: <ul style="list-style-type: none"> • Acknowledge the detected error in the EcoStruxure Machine Expert Logic Builder menu Online > Reset diagnostic messages of controller.
Flashing red / green (4 Hz, 125 ms)	Communication error has been detected. Possible causes: <ul style="list-style-type: none"> • Improper functioning of the telegram • CRC error detected 	Reset condition: <ul style="list-style-type: none"> • The configuration shows which error has been detected. • Acknowledge the detected error in the EcoStruxure Machine Expert Logic Builder menu Online > Reset diagnostic messages of controller.
Steady orange	The device is in a communications phase CP0 up to and including CP3. Sercos telegrams are received.	–
Flashing orange (4 Hz, 125 ms)	Device identification	NOTE: The identified device is also displayed by the axis state LED indicator on the drive.

NOTE: The communication phase information is available as follow while in steady orange state:

- Communication phase is CP0: Steady orange
- Communication phase is CP1: One brief green flash followed by steady orange
- Communication phase is CP2: Two brief green flashes followed by steady orange
- Communication phase is CP3: Three brief green flashes followed by steady orange

Indicators of the Lexium 62 Servo Drive

Overview

The display of the Lexium 62 Servo Drives consists of multi-color LED indicators that are used to display status information.

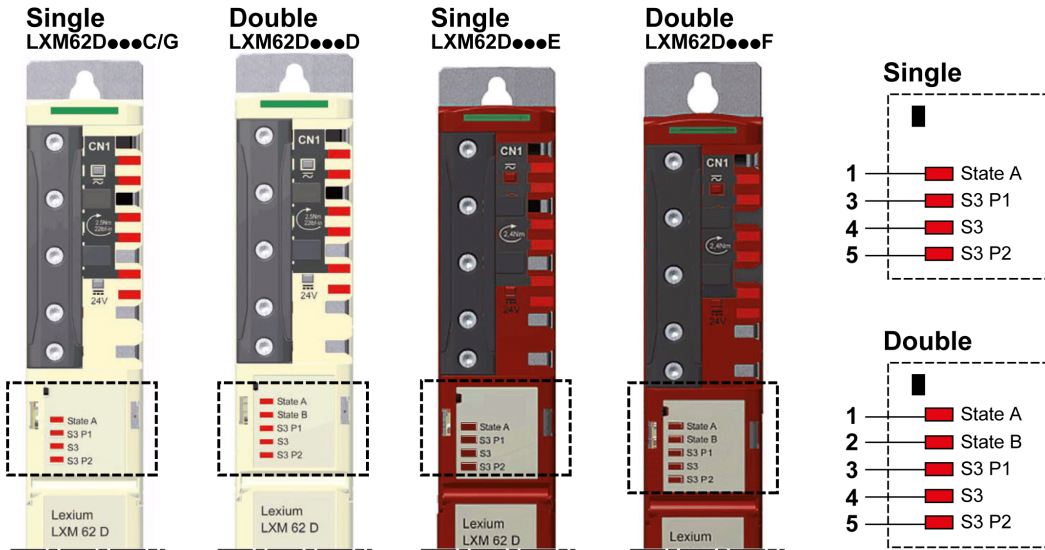

- 1 LED indicator for axis A
- 2 LED indicator for axis B (double servo drives only)
- 3 LED indicator for the status of the Sercos III communication port 1
- 4 LED indicator for the Sercos III communication
- 5 LED indicator for the status of the Sercos III communication port 2

Reset Button

Press the reset button to reset and restart the Lexium 62 Servo Drive.

State LED Indicators

LED indicator color / status	Description	Instructions / information for the user
Off	Device is not energized or is otherwise inoperable.	<ul style="list-style-type: none"> Verify the power supply. Replace device.
Flashing slowly green (2 Hz, 250 ms)	Initialization of the device (firmware boot process, compatibility verification of the hardware, updating the firmware)	<ul style="list-style-type: none"> Wait until initialization is complete.
Flashing green (4 Hz, 125 ms)	Identification of the device	<ul style="list-style-type: none"> If necessary, identify the device via EcoStruxure Machine Expert as defined by the controller configuration.
Steady green	Device has been initialized and waits for the configuration.	<ul style="list-style-type: none"> Configure device as active. Configure device as inactive. Configure device for the execution of motions.

LED indicator color / status	Description	Instructions / information for the user
Steady red	A non-recoverable error has been detected requiring user intervention: <ul style="list-style-type: none"> • Watchdog • Firmware • Checksum • Internal error detected 	<ul style="list-style-type: none"> • Cycle power (power reset) • If this condition persists, replace the device.
Flashing slowly red (2 Hz, 250 ms)	A general error has been detected.	<ul style="list-style-type: none"> • The Devices tree in EcoStruxure Machine Expert displays the error detected. • Reset error detected in the EcoStruxure Machine Expert Logic Builder menu Online > Reset diagnostic messages of controller. • Otherwise restart device.

S3 P1 and S3 P2 LED Indicators

LED indicator color / status	Description	Instructions / information for the user
Off	Possible causes: <ul style="list-style-type: none"> • No cable connected • The device is not energized 	<ul style="list-style-type: none"> • Connect the cable. • Verify the power supply.
Steady orange	Cable connected, no Sercos communication	–
Steady green	Cable connected, active Sercos communication	–

S3 LED Indicator

LED indicator color / status	Description	Instructions / information for the user
Off	Possible causes: <ul style="list-style-type: none"> • The device is not energized or is otherwise inoperable, or • there is no communication due to an interrupted or separated connection. 	<ul style="list-style-type: none"> • Verify the power supply. • Sercos boot-up or hot swap
Steady green	Active Sercos connection without an error detected in the CP4.	–
Flashing green (4 Hz, 125 ms)	The device is in loopback mode. Loopback describes the situation in which the Sercos telegrams have to be sent back on the same port on which they were received. Possible causes: <ul style="list-style-type: none"> • Line topology or • Sercos loop break 	Workaround: <ul style="list-style-type: none"> • Close ring. Reset condition: <ul style="list-style-type: none"> • Acknowledge the detected error in the EcoStruxure Machine Expert Logic Builder menu Online > Reset diagnostic messages of controller. • Switch from CP0 to CP1 alternatively. NOTE: If during phase CP1 a line topology or ring break was detected (device in loopback mode), the LED indicator condition does not change.
Steady red	Sercos diagnostic class 1 (DC1) error has been detected on port 1 and/or port 2.	Reset condition: <ul style="list-style-type: none"> • Acknowledge the detected error in the EcoStruxure Machine Expert Logic Builder menu Online > Reset diagnostic messages of controller.
Flashing red / green (4 Hz, 125 ms)	Communication error has been detected. Possible causes: <ul style="list-style-type: none"> • Improper functioning of the telegram • CRC error detected 	Reset condition: <ul style="list-style-type: none"> • The configuration shows which error has been detected. • Acknowledge the detected error in the EcoStruxure Machine Expert Logic Builder menu Online > Reset diagnostic messages of controller.
Steady orange	The device is in a communications phase CP0 up to and including CP3. Sercos telegrams are received.	–
Flashing orange (4 Hz, 125 ms)	Device identification	NOTE: The identified device is also displayed by the axis state LED indicator on the drive.

NOTE: The communication phase information is available as follow while in steady orange state:

- Communication phase is CP0: Steady orange
- Communication phase is CP1: One brief green flash followed by steady orange
- Communication phase is CP2: Two brief green flashes followed by steady orange
- Communication phase is CP3: Three brief green flashes followed by steady orange

Bus Bar Module LED Indicators on the Lexium 62 Power Supply, Lexium 62 Servo Drive, and Lexium 62 DC Link Support Module

Overview

LED indicators on the Bus Bar Module

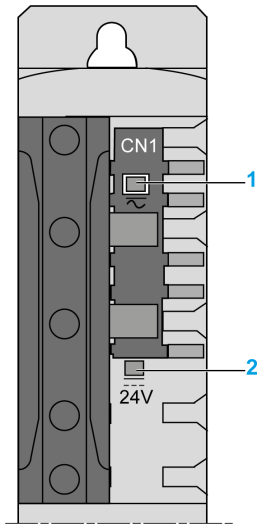

1 DC Bus LED indicator

2 24V LED indicator

DC Bus LED Indicator



LED indicator color / status	Description	Information
Off	DC bus supply inactive	–
Steady red	DC bus supply active	DC bus voltage ≥ 42.4 Vdc

The DC Bus LED indicator is not an indicator for the absence of DC bus voltage.

NOTE: If the DC-bus LED remains off, although the DC-bus is loaded, then the device must be replaced immediately and sent in to Schneider Electric for repair.

24V LED Indicator

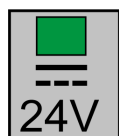



LED indicator color / status	Description
Off	24 Vdc logic supply inactive
Steady green	24 Vdc logic supply active

Electrical Power Connections

Electrical Connections for the Lexium 62 Power Supply

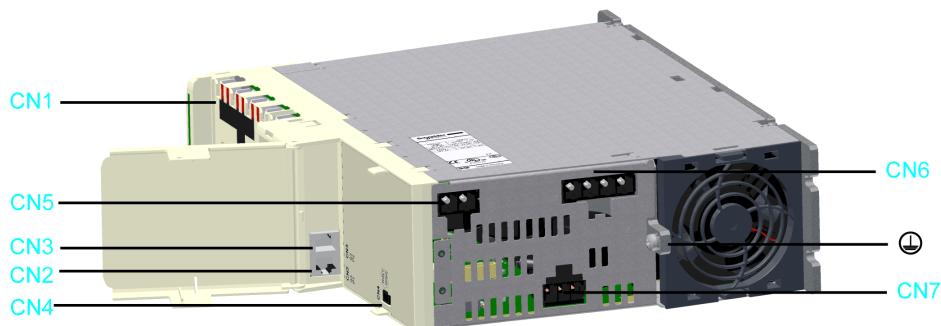
Overview







Connector	Description	Connection cross-section [mm ²] / [AWG]	Tightening torque [Nm] / [lbf in]
CN1, page 148	Bus Bar Module	–	2.5 / 22.14
CN2/CN3, page 149	Sercos communication	–	–
CN4, page 149	Ready relay output	0.2...1.5 / 24...16 ⁽¹⁾	–
CN5, page 149	24 Vdc	0.5...16 / 20...6 ⁽¹⁾	–
CN6, page 150	Mains connection	0.75...16 / 18...6 ⁽¹⁾	–
CN7, page 150	DC bus output	0.2...6 / 24...10 ⁽¹⁾	–
	Protective ground (earth)	10 / 6	3.5 / 30.98
<p>⁽¹⁾ Gauge required for UL conformance. For further information, refer to <i>Conditions for UL Compliant Use</i>, page 45.</p>			

Removable Spring-Clamping Terminal Block Wiring

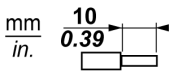



The details in the following table apply for the wiring on the removable spring-clamping terminal block of the **CN4** connection.

Overview of the connection cross-sections for the removable spring-clamping terminal block **CN4** Ready Relay output

	Rigid wire	Flexible wire	Flexible wire with a wire end sleeve without a plastic sleeve	Flexible wire with a wire end sleeve and plastic sleeve
				
mm ²	0.2...1.5	0.2...1.5	0.25...1.5	0.25...0.75
AWG	24...16	24...16	23...16	23...16

The details in the following table apply for the wiring on the removable spring-clamping terminal block of the **CN5, CN6 and CN7** connection.

Overview of the connection cross-sections for the removable spring-clamping terminal block **CN5, CN6 and CN7** Mains connection.

$\frac{\text{mm}}{\text{in.}}$ 18 0.71 	Rigid wire	Flexible wire	Flexible wire with a wire end sleeve⁽¹⁾ without a plastic sleeve	Flexible wire with a wire end sleeve⁽¹⁾ and plastic sleeve
				
mm ²	0.75...16	0.75...16	0.75...16	0.75...10
AWG	18...6	18...6	18...6	18...8
(1) Use crimping tools CRIMPFOX 10 S (for wire cross sections 0.75..10 mm ² , AWG 18..8) and CRIMPFOX 16 S (for wire cross-sections 10...16 mm ² , AWG 8..6) from Phoenix Contact.				

CN1 - Bus Bar Module

The DC bus voltage and the 24 Vdc control voltage are distributed and the protective conductor is connected via the Bus Bar Module.

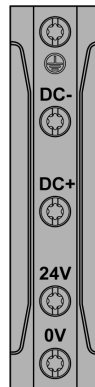

Pin	Designation	Description
1		Protective ground (earth)
2	DC-	DC bus voltage -
3	DC+	DC bus voltage +
4	24 V	Supply voltage +
5	0 V	Supply voltage -

CN2/CN3 - Sercos

The Sercos connection is used for the communication between the controller and the Lexium 62 Power Supply.

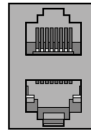

Pin	Designation	Description
1.1	Eth0_Tx+	Positive transmission signal
1.2	Eth0_Tx-	Negative transmission signal
1.3	Eth0_Rx+	Positive receiver signal
1.4	N.C.	Reserved
1.5	N.C.	Reserved
1.6	Eth0_Rx-	Negative receiver signal
1.7	N.C.	Reserved
1.8	N.C.	Reserved
2.1	Eth1_Tx+	Positive transmission signal
2.2	Eth1_Tx-	Negative transmission signal
2.3	Eth1_Rx+	Positive receiver signal
2.4	N.C.	Reserved
2.5	N.C.	Reserved
2.6	Eth1_Rx-	Negative receiver signal
2.7	N.C.	Reserved
2.8	N.C.	Reserved

CN4 - Ready Relay Output

Following initialization of the Lexium 62 Power Supply, the Ready output is activated.

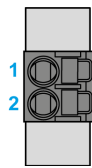

Pin	Designation	Description	Note
1	RDY1	Indicates that the power supply is operational.	Potential-free contact
2	RDY2		

CN5 - 24 V

The 24 V input supplies the internal logic assemblies as well as the holding brakes of the axis group, connected to the axis modules.

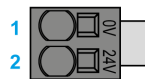

Pin	Designation	Description
1	0 V	Internal supply voltage

Pin	Designation	Description
2	24 V	

The insulation-stripped length of the wires of the 24 V input connector is 18 mm (0.71 in.).

CN6 - Mains Connection

The Power Supply is supplied with voltage via the power connection.

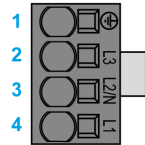

Pin	Designation	Description
1		Protective ground (earth)
2	L3	External conductor L3
3	L2/N	External conductor L2/N
4	L1	External conductor L1

The insulation-stripped length of the wires of the AC infeed connectors is 18 mm (0.71 in.).

CN7 - DC Bus Output

The DC bus output can be used for an external braking resistor module or a recuperation module.

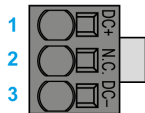



Pin	Designation	Description
1	DC+	DC bus voltage +
2	N.C.	Reserved
3	DC-	DC bus voltage -

The insulation-stripped length of the wires of the DC bus connector is 15 mm (0.59 in.).

Electrical Connections for the Lexium 62 Servo Drives

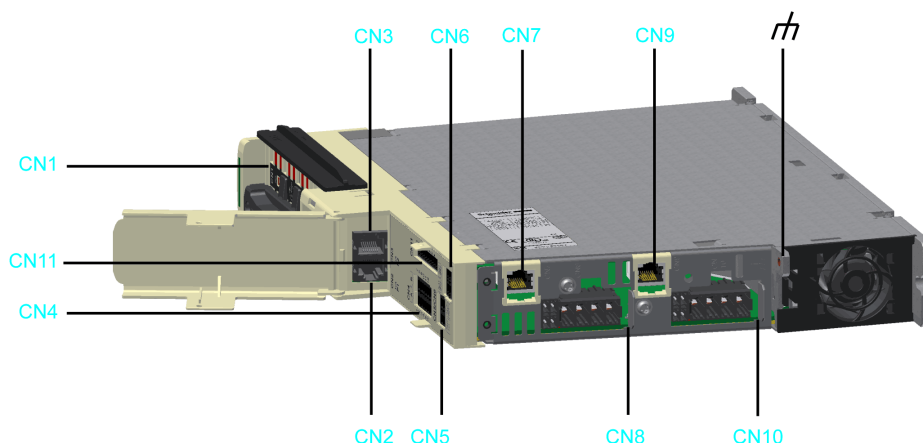
Electrical Connections for the Lexium 62 Variants C, D, E, F



Connector	Description	Connection cross-section [mm ²] / [AWG]	Tightening torque [Nm] / [lbf in]
CN1, page 155	Bus Bar Module	–	2.5 / 22.13
CN2/CN3, page 156	Sercos	–	–
CN4, page 157	Digital inputs/outputs	0.25...1.5 / 24...16	–
CN5, page 158	24 V supply for digital inputs/outputs	0.25...1.5 / 24...16	–
CN6, page 159	Inverter Enable 1-channel ⁽¹⁾	0.2...1.5 / 24...16	–
CN7/CN9, page 161	Encoder connector CN7 - axis A CN9 - axis B (only for double drives)	–	–
CN8, page 162	Motor phases - axis A	0.2...6 / 24...10	–
CN10, page 162	Motor phases - axis B (only for double drives; variants D, F)		
CN11, page 163	Inverter Enable 2-channel	0.2 - 1.5 / 24 - 16	–
	Functional ground (earth)	Mounting point for the shield ⁽²⁾	3.5 / 30.98
<p>(1) Valid only for Lexium 62 variants C/D, refer to <i>Extended Safety-Related Functions - Inverter Enable via Hardware Input</i>, page 75</p> <p>(2) Refer to <i>External Shield Connection on the Drive Module (LMX62DU and LMX62DD)</i>, page 120</p>			

Electrical Connections for the Lexium 62 Variant G

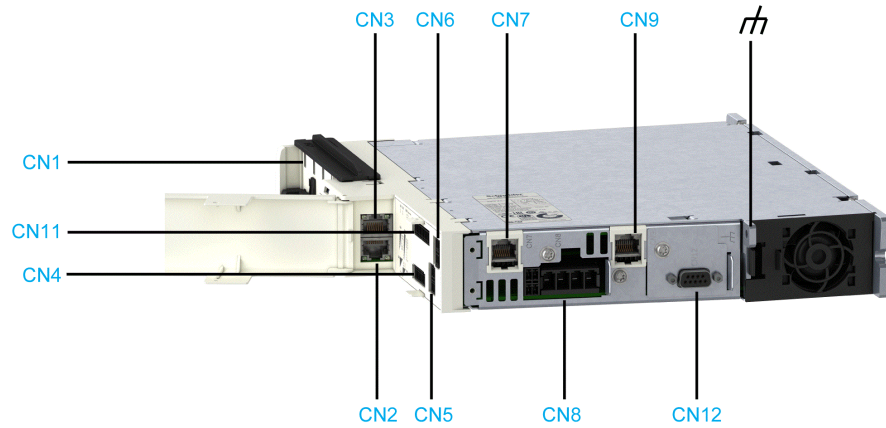

Connector	Description	Connection cross-section [mm ²] / [AWG]	Tightening torque [Nm] / [lbf in]
CN1, page 155	Bus Bar Module	–	2.5 / 22.13
CN2/CN3, page 156	Sercos	–	–
CN4, page 157	Digital inputs/outputs	0.25...1.5 / 24...16	–
CN5, page 158	24 V supply for digital inputs/outputs	0.25...1.5 / 24...16	–
CN6, page 159	Inverter Enable 1-channel	0.2...1.5 / 24...16	–
CN7/CN9, page 161	CN7 - Encoder connector CN9 - Additional machine encoder input	–	–
CN8, page 162	Motor phases - axis A	0.2...6 / 24...10	–
CN11, page 163	Inverter Enable 2-channel	0.2 - 1.5 / 24 - 16	–
CN12, page 164	Machine Encoder Output	0.2...6 / 24...10	–
	Functional ground (earth)	Mounting point for the shield ⁽¹⁾	3.5 / 30.98

(1) Refer to *External Shield Connection on the Drive Module (LMX62DU and LMX62DD)*, page 120

Electrical Connections for the Single Drive LXM62DC13

LXM62DC13 variant C/E

LXM62DC13 variant G

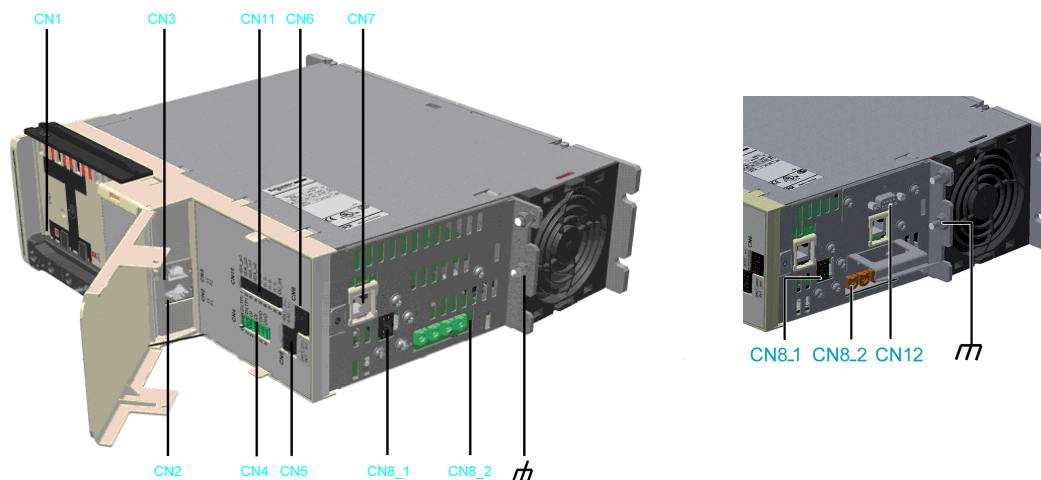

Connector	Description	Connection cross-section [mm²] / [AWG]	Tightening torque [Nm] / [lbf in]
CN1, page 155	Bus Bar Module	–	2.5 / 22.13
CN2/CN3, page 156	Sercos	–	–
CN4, page 157	Digital inputs/outputs	0.25...1.5 / 24...16	–
CN5, page 158	24 V supply for digital inputs/outputs	0.25...1.5 / 24...16	–
CN6, page 159	Inverter Enable 1-channel ⁽¹⁾	0.2...1.5 / 24...16	–
CN7, page 161	Encoder connector	–	–
CN8_1, page 162	Motor temperature / holding brake	0.2...1.5 / 24...16	–
CN8_2, page 162	Motor phases	4...6 / 12...10	–
CN11, page 163	Inverter Enable 2-channel	0.2 - 1.5 / 24 - 16	–
CN12, page 164	Machine Encoder Output (only for LXM62DC13G)	0.2...6 / 24...10	–
	Functional ground (earth)	Mounting point for the shield ⁽²⁾	3.5 / 30.98



(1) Valid **only** for Lexium 62 variants C/G, refer to *Extended Safety-Related Functions - Inverter Enable via Hardware Input*, page 75

(2) Refer to *External Shield Connection on the Drive Module LXM62DC13*, page 122.

Removable Spring-Clamping Terminal Block Wiring

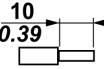

The details in the following table apply for the wiring on the removable spring-clamping terminal block of the **CN4, CN5, CN6, CN8 / CN10** (holding brake, temperature) and **CN11** connections.

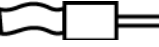
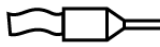
Overview of the connection cross-sections for the removable spring-clamping terminal blocks **CN4, CN5, CN6, CN8 / CN10** (holding brake, temperature) and **CN11**:

$\frac{\text{mm}}{\text{in.}}$ 	Rigid wire	Flexible wire	Flexible wire with a wire end sleeve without a plastic sleeve	Flexible wire with a wire end sleeve and plastic sleeve
				
mm ²	0.2...1.5	0.2...1.5	0.25...1.5	0.25...0.75
AWG	24...16	24...16	23...16	23...19

The details in the following table apply for the wiring on the removable spring-clamping terminal blocks of the connections **CN8 / CN10** (PE, U, V, W).

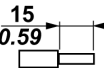
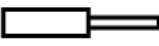
Overview of the connection cross-sections for the removable spring-clamping terminal blocks **CN8 / CN10** motor phases (PE, U, V, W):

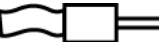
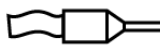
$\frac{\text{mm}}{\text{in.}}$ 	Rigid wire	Flexible wire	Flexible wire with a wire end sleeve without a plastic sleeve	Flexible wire with a wire end sleeve and plastic sleeve
				
mm ²	0.2...10	0.2...6 0.2...10 ⁽¹⁾	0.25...6	0.25...4
AWG	24...8	24...10 24...8 ⁽¹⁾	23...10	23...12
(1) Flexible conductors with an outside diameter of ≤ 4 mm				

CN1 - Bus Bar Module

The DC bus voltage and the 24 Vdc control voltage are distributed and the protective conductor is connected via the Bus Bar Module.



Pin	Designation	Description
1		Protective ground (earth)
2	DC-	DC bus voltage -
3	DC+	DC bus voltage +
4	24 V	Supply voltage +
5	0 V	Supply voltage -

CN2/3 - Sercos

The Sercos connection is used for the communication between the controller and the drive.

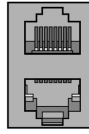

Pin	Designation	Description
1.1	Eth0_Tx+	Positive transmission signal
1.2	Eth0_Tx-	Negative transmission signal
1.3	Eth0_Rx+	Positive receiver signal
1.4	N.C.	Reserved
1.5	N.C.	Reserved
1.6	Eth0_Rx-	Negative receiver signal
1.7	N.C.	Reserved
1.8	N.C.	Reserved
2.1	Eth1_Tx+	Positive transmission signal
2.2	Eth1_Tx-	Negative transmission signal
2.3	Eth1_Rx+	Positive receiver signal
2.4	N.C.	Reserved
2.5	N.C.	Reserved
2.6	Eth1_Rx-	Negative receiver signal
2.7	N.C.	Reserved
2.8	N.C.	Reserved

CN4 - Digital Inputs / Outputs

The connection **CN4** provides several digital inputs and outputs on the drive:

- The digital inputs A_DI1 / A_DI2 (Single Drive) or A_DI1, A_DI2 / B_DI1, B_DI2 (Double Drive) can be configured as digital inputs or as Touchprobe inputs via the EcoStruxure Machine Expert Logic Builder.
- The digital inputs A_DI5 / A_DI6 (Single Drive) or A_DI5, A_DI6 / B_DI5, B_DI6 can be configured as digital inputs or as digital outputs via the EcoStruxure Machine Expert Logic Builder.
- The filter time constant of the digital inputs can be set to 1 ms or 5 ms.
- The filter time constant of the Touchprobe inputs is fixed at 100 µs.

Single Drive

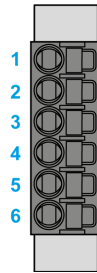

Double Drive

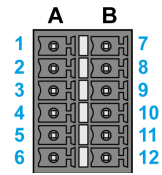

Pin	Designation	Description
1	A_DI0	Axis A – Digital input 0 - Touchprobe
2	A_DI1	Axis A – Digital input 1 - Touchprobe
3	A_DI2	Axis A – Digital input 2
4	A_DI3	Axis A – Digital input 3
5	A_DI4	Axis A – Digital input / output 4
6	A_DI5	Axis A – Digital input / output 5
7	B_DI0	Axis B – Digital input 0 - Touchprobe (only Double Drive)
8	B_DI1	Axis B – Digital input 1 - Touchprobe (only Double Drive)
9	B_DI2	Axis B – Digital input 2 (only Double Drive)
10	B_DI3	Axis B – Digital input 3 (only Double Drive)
11	B_DI4	Axis B – Digital input/output 4 (only Double Drive)
12	B_DI5	Axis B – Digital input/output 5 (only Double Drive)

CN5 - 24 V

The 24 V DIO supply connector supplies the digital inputs/outputs of the drives with the required energy. The connection 0V1 is internally connected to 0V2 and the connection 24V1 is internally connected to 24V2 electrically.

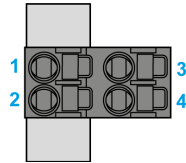

Pin	Designation	Description
1	24V1	Digital I/O supply voltage Axis A
2	0V1	
3	24V2	Digital I/O supply voltage Axis B
4	0V2	

NOTE: For the digital inputs/outputs, if the 24 V supply is interconnected to any additional devices via the connection **CN5**, the maximum current carrying capacity must be respected:

- Continuous current carrying capacity of the plug-in connectors: 3 A
- Maximum current carrying capacity of the plug-in connectors: 4 A, 1 s

The number of the devices that can be connected depends on the application.

CN6 - Inverter Enable 1-Channel

The Inverter Enable signal supplies the gate driver with voltage. In this way, the STO (Safe Torque Off) requirements according to EN 61508 and ISO 13849-1 are met. **IEA1** is internally connected with **IEA2** electrically, and **IEB1** is internally connected with **IEB2** electrically.

The single channel Inverter Enable is valid **only** for Lexium 62 variants C/D/G, refer to *Extended Safety-Related Functions - Inverter Enable via Hardware Input*, page 75.

⚠ DANGER

INADEQUATE SAFETY FUNCTION

Do not use 1-channel Inverter Enable wiring with Lexium 62 variants E/F.

Failure to follow these instructions will result in death or serious injury.

CN6 - Inverter Enable 1-Channel (CN6/CN11 - Inverter Enable)

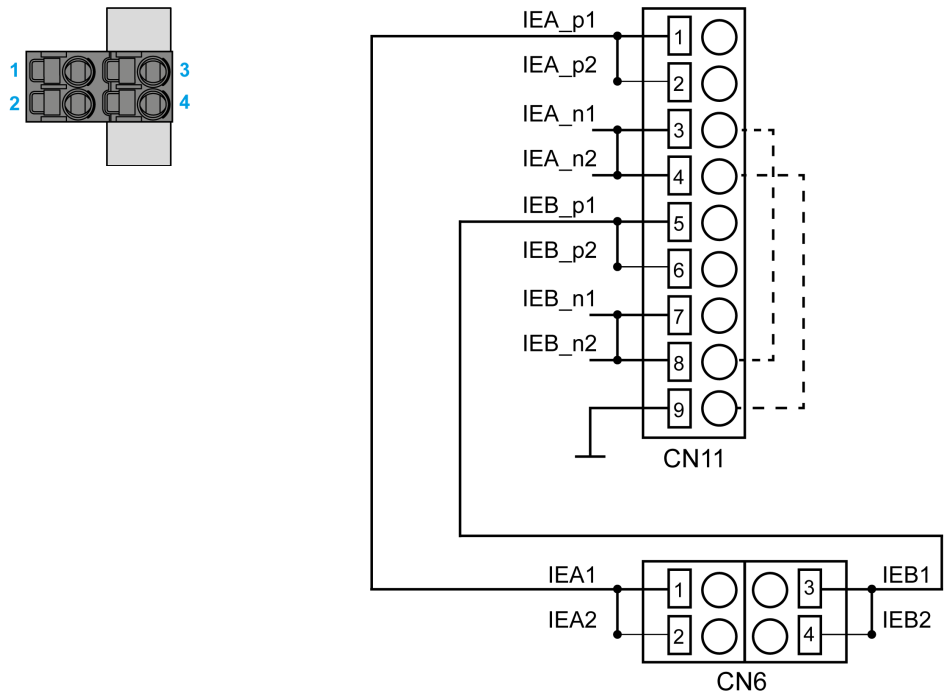

— Internal connections between **CN6** and **CN11**

- - - Possible connection to use the two-channel Inverter Enable as a single-channel Inverter Enable

The single channel Inverter Enable is valid **only** for Lexium 62 variants C/D/G, refer to *Extended Safety-Related Functions - Inverter Enable via Hardware Input*, page 75.

Pin	Designation	Description
1	IEA1	Inverter Enable signal for axis A (with CN11 PIN 1, CN11 PIN 2 and CN6 PIN 2 jumpered)
2	IEA2	Inverter Enable signal for axis A (with CN11 PIN 2, CN11 PIN 1 and CN6 PIN 2 jumpered)
3	IEB1	Inverter Enable signal for axis B (with CN11 PIN 5, CN11 PIN 6 and CN6 PIN 4 jumpered)
4	IEB2	Inverter Enable signal for axis B (with CN11 PIN 6, CN11 PIN 5 and CN6 PIN 3 jumpered)

NOTE: For the gate drivers connected via the connection **CN6**, the maximum current carrying capacity must be respected:

- Continuous current carrying capacity of the plug-in connectors: 3 A
- Maximum current carrying capacity of the plug-in connectors: 4 A, 1 s
- Maximum consumption per drive: 30 mA

The number of the devices that can be connected depends on the application.

CN7 / CN9 - Encoder Connector

The Hiperface connection consists of a standard, differential, digital connection (RS-485 = 2 wires), a differential, analog connection (sine- and cosine signal = 4 wires), and a mains connection to supply the encoder (+10 V, GND = 2 wires).

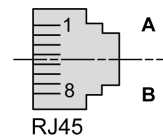

Pin	Designation	Description
1	Cos	Cosine track axis A/B
2	RefCos	Reference signal cosine axis A/B
3	Sin	Sine track axis A/B
4	RS485+	Positive RS-485 signal axis A/B
5	RS485-	Negative RS-485 signal axis A/B
6	RefSin	Reference signal Sine axis A/B
7	N.C.	Reserved
8	N.C.	Reserved
A	P10V	Supply voltage encoder A/B
B	GND	0 V A/B return

NOTE: With the 5 V encoder adapter, page 185, it is also possible to connect encoders with 5 V supply voltage to the Lexium 62 Servo Drive, page 185.

CN8 / CN10 - Motor Connection

The motor signals U, V, and W supply the motor with the required energy. The temperature signals are connected to a temperature sensor to measure the temperature of the motor. The holding brake output supplies the holding brake in the motor with the required energy.

Lexium 62 Drives except DC13

Lexium 62 DC13 Drives

CN8 / CN10 - motor connector

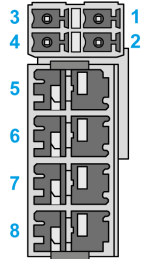

CN8_1 - motor temperature and holding brake

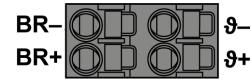

CN8_2 - motor phases

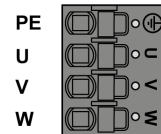

Pin	Designation	Description
1	ϑ-	Temperature negative signal
2	ϑ+	Temperature positive signal
3	BR-	Brake negative signal
4	BR+	Brake positive signal
5	PE	Protective Earth (ground)
6	U	Motor phase U
7	V	Motor phase V
8	W	Motor phase W

Motor cable ⁽¹⁾		Motor connectors	Description
Label of cable core	Color of cable core	Label	
1	Black	U	Motor phase U - Axis A/B
2	Black	V	Motor phase V - Axis A/B
3	Black	W	Motor phase W - Axis A/B
-	Green/Yellow		Protective ground (earth) - Axis A/B
5	Black	ϑ-	Temperature negative signal - Axis A/B
6	Black	ϑ+	Temperature positive signal - Axis A/B
7	Black	BR-	Holding brake negative signal - Axis A/B
8	Black	BR+	Holding brake positive signal - Axis A/B

(1) Order numbers: VW3E1143Rxxx, VW3E1144Rxxx, VW3E1145Rxxx

The insulation-stripped length of the wires of the motor connector is 15 mm (0.59 in.). The maximum length of the motor supply cable is 75 m (246.06 ft).

CN11 - Inverter Enable 2-Channel

CN11 - Inverter Enable 2-Channel (CN6/CN11 - Inverter Enable)

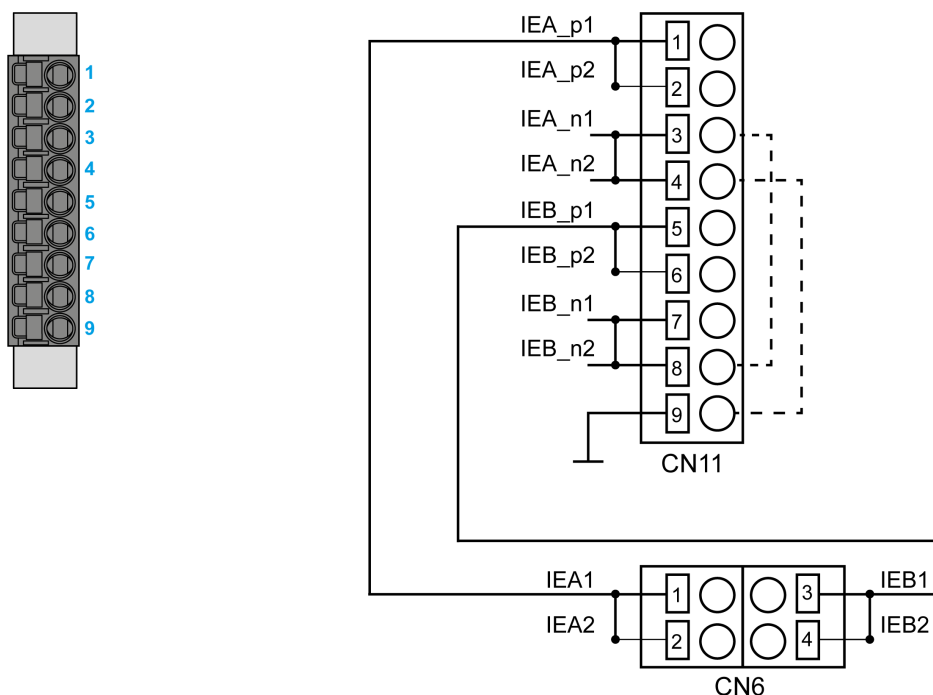

— Internal connections between CN6 and CN11

- - - Possible connection to use the two-channel Inverter Enable as a single-channel Inverter Enable

The single channel Inverter Enable is valid **only** for Lexium 62 variants C/D/G, refer to *Extended Safety-Related Functions - Inverter Enable via Hardware Input*, page 75.

Pin	Designation	Description
1	IEA_p1	Inverter Enable signal for drive A 24 V (with CN6 PIN 1, CN6 PIN 2 and CN11 PIN 2 jumpered)
2	IEA_p2	Inverter Enable signal for drive A 24 V (with CN6 PIN 1, CN6 PIN 2 and CN11 PIN 1 jumpered)
3	IEA_n1	Inverter Enable signal for drive A 0 V external
4	IEA_n2	Inverter Enable signal for drive A 0 V external
5	IEB_p1	Inverter Enable signal for drive B 24 V (with CN6 PIN 3, C6 PIN 4 and CN11 PIN 6 jumpered)
6	IEB_p2	Inverter Enable signal for drive B 24 V (with CN6 PIN 4, C6 PIN 3 and CN11 PIN 5 jumpered)
7	IEB_n1	Inverter Enable signal for drive B 0 V external
8	IEB_n2	Inverter Enable signal for drive B 0 V external
9	0V_int	Inverter Enable signal 0 V internal

CN12 - Encoder Output Simulation

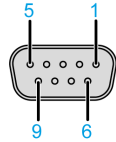

Pin	Designation	Description
1	B-	Encoder Output track B / Differential -
2	B+	Encoder Output track B / Differential +
3	A+	Encoder Output track A / Differential +
4	A-	Encoder Output track A / Differential -
5	n.c.	-
6	n.c.	-
7	Z+	Encoder Output track B / Differential +
8	Z-	Encoder Output track B / Differential -
9	GND_EXT	External Ground

Electrical Connections for the Lexium 62 DC Link Support Module

Overview

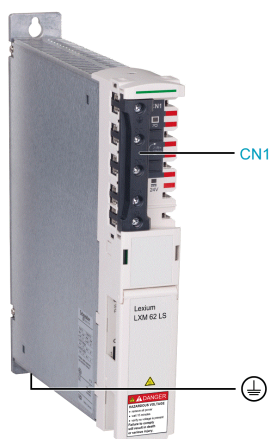

Connector	Description	Tightening torque [Nm] / [lbf in]
CN1, page 165	Bus Bar Module	2.5 / 22
	Protective ground (earth)	3.5 / 30.98

CN1 - Bus Bar Module

The DC bus voltage and the 24 Vdc control voltage are distributed and the protective conductor is connected via the Bus Bar Module.



Pin	Designation	Description
1		Protective earth (ground)
2	DC-	DC bus voltage -
3	DC+	DC bus voltage +
4	24 V	Supply voltage +
5	0 V	Supply voltage -

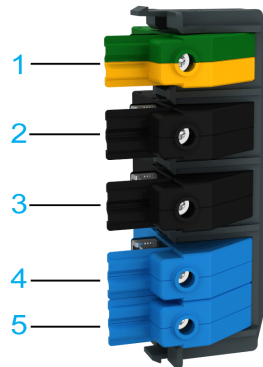

Electrical Connections for the Lexium 62 DC Link Terminal

Overview

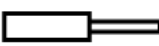

Port / Order	Connector	Color	Label
1	PE Protective earth (ground)	Green/Yellow	
2	DC bus connector	Black	DC-
3			DC+
4	24 V connector	Blue	24 V
5			0 V

Overview of the Connection Cross-Sections

$\frac{\text{mm}}{\text{in.}}$ 18 0.71	Rigid wire	Flexible wire with a cable end (without insulating sleeve)
		
mm ²	10...50	10...35
AWG	8...1	8...2

NOTE: Use copper conductors only.

Tightening Torque

Terminal	Tightening torque [Nm] / [lbf in]
Clamping screw for fixing the terminal to the Bus Bar Module	2.5 / 22
Clamping screw for fixing the wire to the terminal	4.5 / 39.8

Technical Data

Standards and Regulations

Overview

Standards and regulations - Lexium 62 Power Supply

CE	Low Voltage Directive 2014/35/EU
	<ul style="list-style-type: none"> EN 61800-5-1
	EMC Directive 2014/30/EU
	<ul style="list-style-type: none"> EN 61800-3
UL	EN 61800-5-1
CSA	CSA-C22.2 No. 274

Standards and regulations - Lexium 62 Servo Drive

CE	Machinery Directive 2006/42/EC
	<ul style="list-style-type: none"> EN 61800-5-2 ISO 13849-1 ISO 13849-2 EN 62061
	According to Annex I 1.5.1: Safety objectives of 2014/35/EU
	<ul style="list-style-type: none"> EN 61800-5-1
	EMC Directive 2014/30/EU
	<ul style="list-style-type: none"> EN 61800-3
UL	UL 61800-5-1
CSA	CSA-C22.2 No. 274
TÜV	<ul style="list-style-type: none"> IEC 61800-5-2 IEC 61508-1 IEC 61508-2 ISO 13849-1 ISO 13849-2 IEC 62061
	Additional for variant E & F:
	<ul style="list-style-type: none"> IEC 61508-3

Standards and regulations - Lexium 62 DC Link Terminal

CE	Low Voltage Directive 2014/35/EU
	<ul style="list-style-type: none"> EN 61800-5-1
	EMC Directive 2014/30/EU
	<ul style="list-style-type: none"> EN 61800-3
UL	UL 1059
CSA	CSA-C22.2 No. 158

Standards and regulations - Lexium 62 DC Link Support Module

CE	Low Voltage Directive 2014/35/EU
	<ul style="list-style-type: none"> EN 61800-5-1
	EMC Directive 2014/30/EU
	<ul style="list-style-type: none"> EN 61800-3
UL	UL 61800-5-1
CSA	CSA-C22.2 No. 274

Standards and regulations - functional safety

Functional safety	Lexium 62 variants C/D/G and E/F (for example, LXM62DU60C): <ul style="list-style-type: none">• ISO 13849-1, PL e• EN 62061, SIL 3• EN 61508, SIL 3
-------------------	---

NOTE: For further information on certifications and the version of applied standards, refer to the dedicated Declarations and Certificates on www.se.com

Ambient Conditions

Overview

Ambient conditions for control cabinet devices:

Procedure	Parameter	Value	Basis
Operation	Class 3K3		IEC/EN 60721-3-3
	Ingress protection rating of the housing	IP20 with installed connectors, and, for LXM62LT, with installed wires.	
	Supplemental ingress protection rating of installed product	IP54	
	Pollution degree	2	
	Ambient temperature	+5...+55 °C (+41...131 °F)	
	<ul style="list-style-type: none"> Power derating above 40 °C (104 °F) 	+40...+55 °C (+104...+131 °F) (starting +40 °C (+104 °F): -2% per K by I _{NC} and I _{SC}) (I _{NC} = nominal current; I _{SC} = peak current)	
	Relative humidity	5...85%	
	<ul style="list-style-type: none"> Condensation 	No	
	<ul style="list-style-type: none"> Formation of ice 	No	
	<ul style="list-style-type: none"> Other water 	No	
	Class 3M4		
	Shock	100 m/s ²	
	Vibration	10 m/s ²	
Transport	Class 2K3		IEC/EN 60721-3-2
	Ambient temperature	-25...+70 °C (-13...+158 °F)	
	Relative humidity	5...95%	
	<ul style="list-style-type: none"> Condensation 	No	
	<ul style="list-style-type: none"> Formation of ice 	No	
	<ul style="list-style-type: none"> Other water 	No	
	Class 2M2		
	Shock	300 m/s ²	
	Vibration	10 m/s ²	
Long-term storage in transport packaging	Class 1K3		IEC/EN 60721-3-1
	Ambient temperature	-25...+55 °C (-13...+131 °F)	
	Relative humidity	5...95%	
	<ul style="list-style-type: none"> Condensation 	No	
	<ul style="list-style-type: none"> Formation of ice 	No	
	<ul style="list-style-type: none"> Other water 	No	

Installation Altitude

The installation altitude is defined as height above sea level.

Characteristic	Value
Installation altitude without power reduction	<1000 m (<3281 ft)
Installation altitude while complying with the following conditions: <ul style="list-style-type: none"> • 55 °C (131 °F) maximum ambient temperature • Reduction of the continuous power by 1% per 100 m (328 ft.) above 1000 m (3281 ft.) 	1000...2000 m (3281...6562 ft.)
Installation altitude above sea level when complying with the following conditions: <ul style="list-style-type: none"> • 40 °C (104 °F) maximum ambient temperature • Reduction of the continuous power by 1% per 100 m (328 ft.) above 1000 m (3281 ft.) • Overvoltages of the supplying grid limited to an overvoltage category II according to IEC 60664-1/IEC 61800-5-1 	2000...3000 m (6562...9843 ft.)

Degree of Protection When Using the Safety Function

Ensure that no conductive pollution can deposit in the product (pollution degree 2).
 Conductive pollution can cause the safety function to be ineffective.

Mechanical and Electrical Data for the Lexium 62 Power Supply

Technical Data for the Lexium 62 Power Supply

Designation	Parameter	Value		
Reference		LXM62PD84A11000	LXM62PD20A11000	
Power supply	Rated supply voltage 3 _{AC}	Minimum 380 Vac (-10%) / Nominal 400 Vac / Maximum 480 Vac (+10%)		
		Minimum 208 Vac (-10%) / Nominal 230 Vac / Maximum 360 Vac (+10%)		
	Adjust the parameter <i>MainsVoltageMode</i> of the power supply according to the nominal supply voltage.			
	Rated supply voltage 1 _{AC}	Minimum 208 Vac (-10%) / Nominal 230 Vac / Maximum 270 Vac (+10%)		
	Rated supply current	Maximum 40 A	Maximum 10 A	
Supply frequency	47.5...63 Hz			
Logic supply	Control voltage	24 Vdc (-20%...+25%)		
	Control current	-		
	Maximum current entry	50 A (no overload permissible)		
	Maximum current consumption	1.2 A		
DC circuit	DC bus voltage	270...700 Vdc		
	DC bus capacitance	1.36 mF		
	Overvoltage	860 Vdc		
	Rated current (I _{Nc})	21 A with 1 _{AC} infeed	10 A with 1 _{AC} infeed	
		42 A with 3 _{AC} infeed	10 A with 3 _{AC} infeed	
	Peak current 1 s (I _{Sc})	42 A with 1 _{AC} infeed	20 A with 1 _{AC} infeed	
		84 A with 3 _{AC} infeed	20 A with 3 _{AC} infeed	
	Rated power	22.1 kW at 3 Vac ~ 400 Vac	5.2 kW at 3 Vac ~ 400 Vac	
		26.6 kW at 3 Vac ~ 480 Vac	6.2 kW at 3 Vac ~ 480 Vac	
	Peak power	44.2 kW at 3 Vac ~ 400 Vac	10.4 kW at 3 Vac ~ 400 Vac	
		53.2 kW at 3 Vac ~ 480 Vac	12.5 kW at 3 Vac ~ 480 Vac	
	U _{Bleeder} ON	830 Vdc		
U _{Bleeder} OFF	810 Vdc			
DC bus unloading time	Maximum 15 min			
Internal braking resistor	Resistance	15 Ω		
	Continuous power	400 W		
	Peak power	46 kW		
	Pulse energy (periodic duty, 120 s)	4000 Ws (HW Rev. 01) 20000 Ws (HW Rev. 02)		
Interface	Sercos	Integrated		
Power loss	Electronics power supply	15 W		
	Power stage	3 W/A (maximum 126 W at 42 A)		
	Braking resistor (internal)	400 W		
Outputs	Relay outputs	Ready relay, up to 6 A (maximum) for 1 s at 150 Vac and 1.5 A (cont.)		
		Ready relay, up to 6 A (maximum) for 1 s at 48 Vdc and 1.5 A (cont.)		
Radio interference level	-	C3 (C2 with additional filter measures)		
Protective class	Class	1 (IEC 61800-5-1)		

Designation	Parameter	Value	
Reference		LXM62PD84A11000	LXM62PD20A11000
Supported Supply Earthing Systems (IEC 60364-1)	TN with grounded wye system	Supported	
	TN with grounded neutral point corner-earthed	Not supported	
	TT systems		
	IT systems		
System Voltage (IEC 61800-5-1)	-	Maximum 300 Vac	
Overvoltage category	–	III (IEC 61800-5-1)	
Ingress protection rating of the housing	IP20 with plug-in connectors	IEC/EN 60721-3-3	
Pollution degree	–	2 (IEC 61800-5-1)	
Weight	Weight (with packaging)	6.3 kg / 7.4 kg (13.9 lbs / 16.3 lbs)	

NOTE: Due to the higher pulse energy of the braking resistor in hardware revision RS 02, the precharge of the system may be delayed up to 50 seconds, depending on the load state or the estimated worst-case load state of the braking resistor. In particular, this longer delay time can be noticed in situations where the load of the braking resistor is undefined to the system (for example after turning on the 24 V supply of the device or after a forced discharge of the DC Bus).

Dimensions - Lexium 62 Power Supply

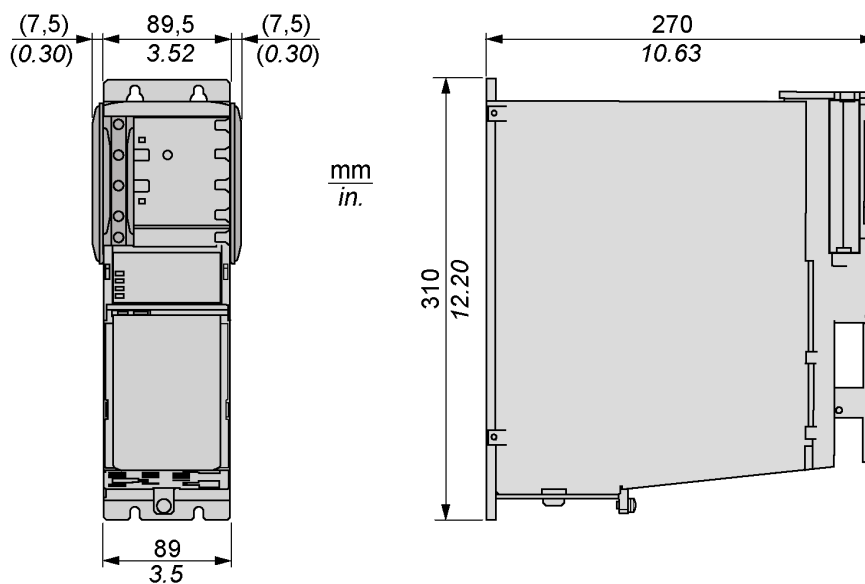

Mechanical and Electrical Data for the Single Drives

Technical Data for the Single Drives

Designation	Parameter	Value				
Product configuration	Item name	LXM62DU60C	LXM62DD15C	LXM62DD27C	LXM62DD45C	LXM62DC13C
		LXM62DU60E	LXM62DD15E	LXM62DD27E	LXM62DD45E	LXM62DC13E
		LXM62DU60G	LXM62DD15G	LXM62DD27G	LXM62DD45G	LXM62DC13G
Power supply	Control voltage (without holding brake)	24 Vdc (-20...+25%)				
		1.1 A	1.1 A	1.1 A	1.1 A	1.5 A
	Maximum current consumption					
	Control voltage (with holding brake)	24 Vdc (0...+6%)				
		2.5 A	2.5 A	2.5 A	3.5 A	3.9 A
	Maximum current consumption					
DC bus voltage	250...700 Vdc					
DC bus continuous current	1.8 A	4.6 A	8.2 A	18.3 A	45.7 A	
DC bus peak current	5.5 A	13.7 A	24.7 A	41.1 A	119.0 A	
DC bus capacitance	110 µF	110 µF	110 µF	220 µF	250 µF	
Overvoltage	900 Vdc					
Motor connection	Rated current (4 kHz)					
	• at 40 °C (104 °F)	2.0 A _{eff}	5.0 A _{eff}	9.0 A _{eff}	20.0 A _{eff}	50.0 A _{eff}
	• at 55 °C (140 °F)	1.4 A _{eff}	3.5 A _{eff}	6.3 A _{eff}	13.7 A _{eff}	35.0 A _{eff}
	Peak current 10 s (4 kHz) at 55 °C (140 °F)	6.0 A _{eff}	15.0 A _{eff}	27.0 A _{eff}	45.0 A _{eff}	130.0 A _{eff} (HW Rev. 02)
	Continuous output power (4 kHz, 400 V mains voltage)					
	• at 40 °C (104 °F)	0.95 kW	2.4 kW	4.3 kW	9.6 kW	24.7 kW
	Overload protection	Yes				
	Short-circuit protection	Yes, IEC 60364-4-41/AMD1:-, Clause 411				
	Output voltage range	3 Vac~ 0...480 Vac				
Output frequency range	0...599 Hz					

Designation	Parameter	Value				
Product configuration	Item name	LXM62DU60C	LXM62DD15C	LXM62DD27C	LXM62DD45C	LXM62DC13C
		LXM62DU60E	LXM62DD15E	LXM62DD27E	LXM62DD45E	LXM62DC13E
		LXM62DU60G	LXM62DD15G	LXM62DD27G	LXM62DD45G	LXM62DC13G
Motor connection	Rated current (8 kHz)					
	• at 40 °C (104 °F)	2.0 A _{eff}	5.0 A _{eff}	7.0 A _{eff}	15.0 A _{eff}	50.0 A _{eff}
	• at 55 °C (140 °F)	1.4 A _{eff}	3.5 A _{eff}	5.0 A _{eff}	8.9 A _{eff}	30.0 A _{eff}
	Peak current 10 s (8 kHz) at 55 °C (140 °F)	6.0 A _{eff}	15.0 A _{eff}	27.0 A _{eff}	45.0 A _{eff}	100.0 A _{eff} (HW Rev. 02)
	Continuous output power (8 kHz, 400 V mains voltage)					
	• at 40 °C (104 °F)	0.95 kW	2.4 kW	3.4 kW	7.2 kW	24.7 kW
	Overload protection	Yes				
	Short-circuit protection	Yes, IEC 60364-4-41/AMD1:-, Clause 411				
	Output voltage range	3 Vac~ 0...480 Vac				
	Output frequency range	0...599 Hz				
Motor connection	Rated current (16 kHz)					
	• at 40 °C (104 °F)	1.2 A _{eff}	3.5 A _{eff}	4.0 A _{eff}	8.0 A _{eff}	30.0 A _{eff}
	• at 55 °C (140 °F)	0.8 A _{eff}	2.6 A _{eff}	2.9 A _{eff}	4.9 A _{eff}	20.0 A _{eff}
	Peak current 10 s (16 kHz) at 55 °C (140 °F)	6.0 A _{eff}	15.0 A _{eff}	27.0 A _{eff}	45.0 A _{eff}	60.0 A _{eff} (HW Rev. 02)
	Continuous output power (16 kHz, 400 V mains voltage)					
	• at 40 °C (104 °F)	0.6 kW	1.7 kW	2.0 kW	3.8 kW	16.8 kW
	Overload protection	Yes				
	Short-circuit protection	Yes, IEC 60364-4-41/AMD1:-, Clause 411				
	Output voltage range	3 Vac~ 0...480 Vac				
	Output frequency range	0...599 Hz				
Motor connection	Maximum length of the motor cable	75 m (246.06 ft)				
Power loss	Electronics power supply	18 W				
Current-dependent power loss	Power stage (4 kHz)	6.6 W/A				
	Power stage (8 kHz)	8.5 W/A				
	Power stage (16 kHz)	14.9 W/A				
Interface	Sercos	Integrated				

Designation	Parameter	Value				
Product configuration	Item name	LXM62DU60C	LXM62DD15C	LXM62DD27C	LXM62DD45C	LXM62DC13C
		LXM62DU60E	LXM62DD15E	LXM62DD27E	LXM62DD45E	LXM62DC13E
		LXM62DU60G	LXM62DD15G	LXM62DD27G	LXM62DD45G	LXM62DC13G
Encoder interface CN7/CN9	Power supply	10 Vdc (-10...+10%), maximum 150 mA, short-circuit protection				
	Differential analog input (sine and cosine signal)	Input voltage: 0.8...1.1 V _{PP}				
		Offset: 2.5 Vdc (-10...+10%)				
		Terminating resistor: 130 Ω				
		SinCos periods per second <ul style="list-style-type: none"> • CN7: <ul style="list-style-type: none"> ◦ 100 kHz (Variants C, D, G) ◦ 20 kHz (Variants E, F) • CN9: <ul style="list-style-type: none"> ◦ 100 kHz (Variants D, G) ◦ 20 kHz (Variants F) 				
Cutoff frequency: Maximum 100.000 SinCos periods / second (maximum 100 kHz)						
	Communication	RS-485 interface				
Digital inputs/ outputs	DIO supply	Voltage U _{DIO} : 24 Vdc (-20...+25%)				
		Maximum current consumption: 1.2 A				
	Digital inputs A_DI3, A_DI4	Inputs with switching level type 1 according to EN 61131-2				
		Low level: -3...5 Vdc				
		High level: 15...30 Vdc				
		Filter time constant normal inputs: 1 ms/5 ms (configurable)				
	Digital inputs or Touchprobe inputs A_DI1, A_DI2	Inputs with switching level type 1 according to EN 61131-2				
		Low level: -3...5 Vdc				
		High level: 15...30 Vdc				
		Filter time constant normal inputs: 1 ms/5 ms (configurable) Filter time constant for Touchprobe inputs: 100 μs				
	Digital inputs or digital outputs A_DI5, A_DI6	Inputs/outputs (bidirectional) with switching level type 1 according to EN 61131-2				
		Inputs: Low level: -3...5 Vdc High level: 15...30 Vdc Filter time constant normal inputs: 1 ms/5 ms (configurable)				
		Outputs: High level: (U _{DIO} - 3 V) < U _{out} < U _{DIO} Maximum output current per output: 500 mA resistive				
Inverter Enable	Maximum current consumption	30 mA				
	Inputs	Number: 1				
		STO active: -3 V ≤ U _{IE} ≤ 5 V				
		Power stage active: 18 V ≤ U _{IE} ≤ 30 V				
		Maximum downtime 500 μs at U _{IE} > 20 V and dynamic activation				
		Maximum switching frequency of input signal: maximum 1 Hz				
Maximum potential difference between IE- and PE	15 V					

Designation	Parameter	Value				
Product configuration	Item name	LXM62DU60C	LXM62DD15C	LXM62DD27C	LXM62DD45C	LXM62DC13C
		LXM62DU60E	LXM62DD15E	LXM62DD27E	LXM62DD45E	LXM62DC13E
		LXM62DU60G	LXM62DD15G	LXM62DD27G	LXM62DD45G	LXM62DC13G
Ventilation	-	Internal fan				
Radio interference level	-	C3 (C2 with additional filter measures)				
Protective class	Class	I (IEC 61800-5-1)				
Overvoltage category	-	III (IEC 61800-5-1)				
Pollution degree	-	2 (IEC 61800-5-1)				
Motor brake	Output voltage	Control voltage minus 0.8 Vdc				
	Output current	1.2 A (maximum)			2.2 A (maximum)	
	Inductance	1.0 H (maximum)			1.5 H (maximum)	
	Energy inductive load	1.2 J (maximum)			4.5 J (maximum)	
	Overload protection	Yes				
	Short-circuit protection	Yes				
Motor temperature	Sensor Input	PTC, KTY				
	Sensorless	Encoder temperature with thermal model. No thermal memory retention after reset of device.				
Motor temperature sensor	-	Maximum voltage: 5 V Maximum current: 2.5 mA				
Weight	Weight (without packaging)	3 kg (6.6 lbs)			6.8 kg (14.9 lbs)	
	Weight (with packaging)	3.91 kg (8.62 lbs)			7.8 kg (17.2 lbs)	
<p>NOTE:</p> <ul style="list-style-type: none"> Lexium 62 Single Drive includes the variants C and G: LXM62DU60C/G, LXM62DD15C/G, LXM62DD27C/G, LXM62DD45C/G, LXM62DC13C/G Lexium 62 Single Drive embedded safety includes the variant E: LXM62DU60E, LXM62DD15E, LXM62DD27E, LXM62DD45E, LXM62DC13E 						

NOTE: Due to the increased control current of the brake (approximately 2 A), the motor series SH3205xxxxFxx00 with holding brake can only be operated at the servo converters of type Lexium 62 single drive (LXM62DD45C or LXM62DD45E) and LXM62DC13C21000/LXM62DC13E21000.

Dimensions - Single Drives

Dimensions of the Lexium 62 Servo Drive (excluding LXM62DC13C21000/
LXM62DC13E21000/LXM62DC13G21000):

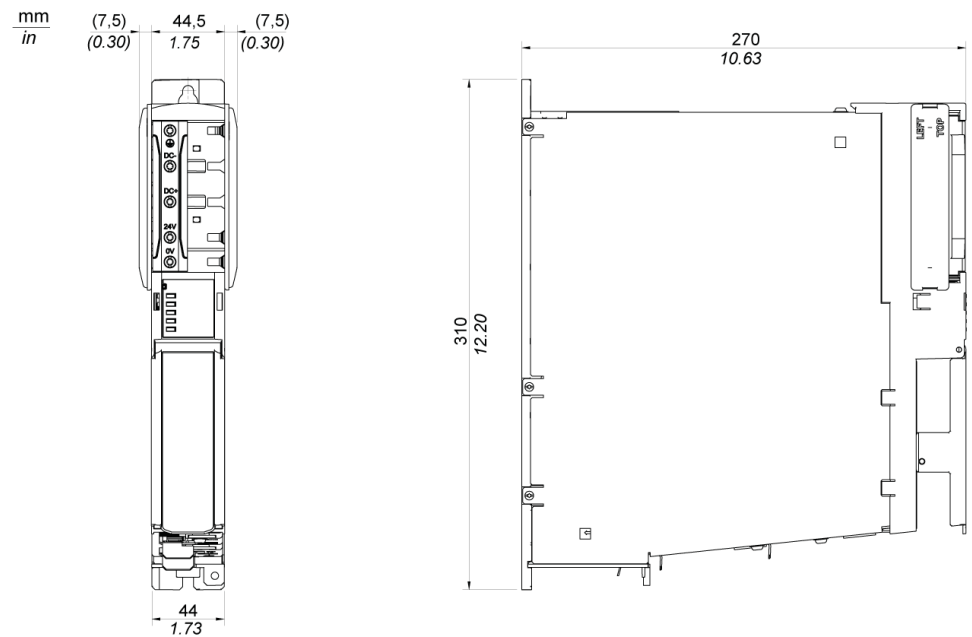

Dimensions of the Lexium 62 Servo Drive (only LXM62DC13C21000/
LXM62DC13E21000/LXM62DC13G21000):

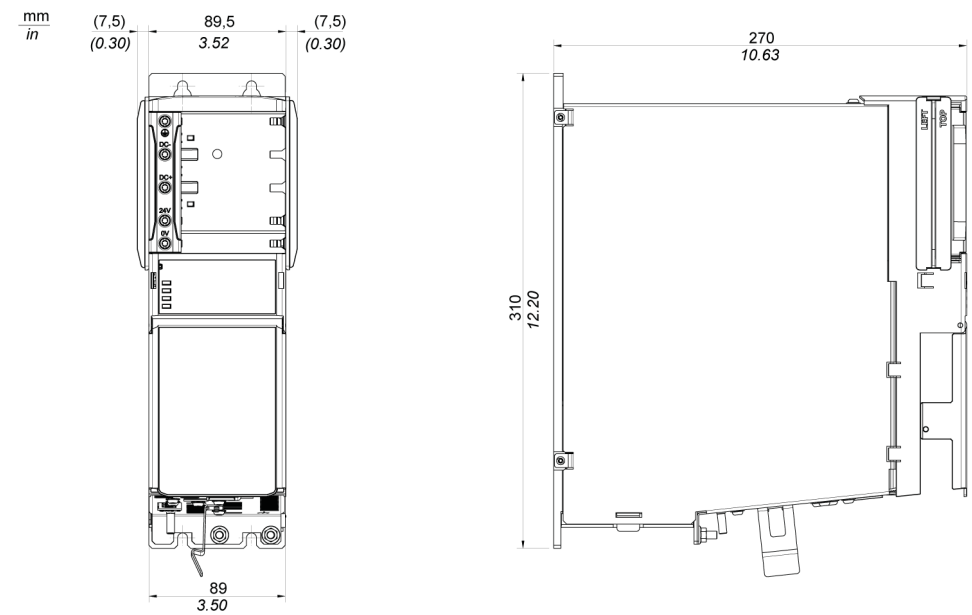

Mechanical and Electrical Data for the Double Drives

Technical Data for the Double Drives

Designation	Parameter	Value		
Product configuration	Item name	LXM62DU60D	LXM62DD15D	LXM62DD27D
		LXM62DU60F	LXM62DD15F	LXM62DD27F
Power supply	Control voltage (without holding brakes)	24 Vdc (-20...+25%)		
	Maximum current consumption	1.3 A	1.3 A	1.3 A
	Control voltage / control current (with holding brakes)	24 Vdc (0...+6%)		
	Maximum current consumption	4.1 A	4.1 A	4.1 A
	DC bus voltage	250...700 Vdc		
	DC bus continuous current	3.6 A	9.2 A	16.4 A
	DC bus peak current	11.0 A	27.4 A	49.4 A
	DC bus capacitance	110 µF		
	Overvoltage	900 Vdc		
Motor connection	Rated current (4 kHz)			
	• at 40 °C (104 °F)	2.0 A _{eff}	5.0 A _{eff}	9.0 A _{eff}
	• at 55 °C (140 °F)	1.4 A _{eff}	3.5 A _{eff}	6.3 A _{eff}
	Peak current 10 s (4 kHz) at 55 °C (114 °F)	6.0 A _{eff}	15.0 A _{eff}	27.0 A _{eff}
	Continuous output power per axis (4 kHz, 400 V mains voltage)			
	• at 40 °C (104 °F)	0.95 kW	2.4 kW	4.3 kW
	Output voltage range	3 Vac~ 0...480 Vac		
	Output frequency range	0...599 Hz		
Motor connection	Rated current (8 kHz)			
	• at 40 °C (104 °F)	2.0 A _{eff}	5.0 A _{eff}	7.0 A _{eff}
	• at 55 °C (140 °F)	1.4 A _{eff}	3.5 A _{eff}	5.0 A _{eff}
	Peak current 10 s (8 kHz) at 55 °C (140 °F)	6.0 A _{eff}	15.0 A _{eff}	27.0 A _{eff}
	Continuous output power per axis (8 kHz, 400 V mains voltage)			
	• at 40 °C (104 °F)	0.95 kW	2.4 kW	3.4 kW
	Output voltage range	3 Vac~ 0...480 Vac		
	Output frequency range	0...599 Hz		
Motor connection	Rated current (16 kHz)			
	• at 40 °C (104 °F)	1.2 A _{eff}	3.5 A _{eff}	4.0 A _{eff}
	• at 55 °C (140 °F)	0.8 A _{eff}	2.6 A _{eff}	2.9 A _{eff}
	Peak current 10 s (16 kHz) at 55 °C (140 °F)	6.0 A _{eff}	15.0 A _{eff}	27.0 A _{eff}
	Continuous output power per axis (16 kHz, 400 V mains voltage)			
	• at 40 °C (104 °F)	0.6 kW	1.7 kW	2.0 kW
	Output voltage range	3 Vac~ 0...480 Vac		
	Output frequency range	0...599 Hz		

Designation	Parameter	Value		
Product configuration	Item name	LXM62DU60D	LXM62DD15D	LXM62DD27D
		LXM62DU60F	LXM62DD15F	LXM62DD27F
Motor connection	Maximum length of the motor cable	75 m (246.06 ft)		
Power loss	Electronics power supply (8 kHz)	22 W		
	Power stage (8 kHz)	8.5 W/A (per axis)		
Interface	Sercos	Integrated		
Encoder interface CN7/ CN9	Power supply	10 Vdc (-10...+10%), maximum 150 mA, short-circuit protection		
	Differential analog input (sine and cosine signal)	Input voltage: 0.8...1.1 V _{PP}		
		Offset: 2.5 Vdc (-10...+10%)		
		Terminating resistor: 130 Ω		
		SinCos periods per second <ul style="list-style-type: none"> • CN7: <ul style="list-style-type: none"> ◦ 100 kHz (Variants C, D, G) ◦ 20 kHz (Variants E, F) • CN9: <ul style="list-style-type: none"> ◦ 100 kHz (Variants D, G) ◦ 20 kHz (Variants F) 		
Cutoff frequency: Maximum 100.000 SinCos periods / second (maximum 100 kHz)				
Digital inputs/ outputs	DIO supply	Voltage U _{DIO} : 24 Vdc (-20...+25%)		
		Maximum current consumption: 2.2 A		
	Digital inputs A_DI3, A_DI4 B_DI1, B_DI4	Inputs with switching level type 1 according to EN 61131-2		
		Low level: -3...5 Vdc		
		High level: 15...30 Vdc		
		Filter time constant normal inputs: 1 ms/5 ms (configurable)		
	Digital inputs or Touchprobe inputs A_DI1, A_DI2 B_DI1, B_DI2	Inputs with switching level type 1 according to EN 61131-2		
		Low level: -3...5 Vdc		
		High level: 15...30 Vdc		
		Filter time constant normal inputs: 1 ms/5 ms (configurable)		
	Filter time constant for Touchprobe inputs: 100 μs			
	Digital inputs or digital outputs A_DI5, A_DI6 B_DI5, B_DI6	Inputs/outputs (bidirectional) with switching level type 1 according to EN 61131-2		
		Inputs:		
Low level: -3...5 Vdc				
High level: 15...30 Vdc				
Filter time constant normal inputs: 1 ms/5 ms (configurable)				
Outputs:				
High level: (U _{DIO} - 3 V) < U _{out} < U _{DIO}				
Maximum output current per output: 500 mA resistive				

Designation	Parameter	Value		
Product configuration	Item name	LXM62DU60D	LXM62DD15D	LXM62DD27D
		LXM62DU60F	LXM62DD15F	LXM62DD27F
Inverter Enable	Maximum current consumption	30 mA		
	Inputs	Number: 2		
		STO active: $-3\text{ V} \leq U_{IE} \leq 5\text{ V}$		
		Power stage active: $18\text{ V} \leq U_{IE} \leq 30\text{ V}$		
		Maximum downtime 500 μs at $U_{IE} > 20\text{ V}$ and dynamic activation		
		Maximum switching frequency of input signal: maximum 1 Hz		
Maximum potential difference between IE- and PE	15 V			
Ventilation	-	Internal fan		
Radio interference level	-	C3 (C2 with additional filter measures)		
Protective class	Class	I (IEC 61800-5-1)		
Overvoltage category	-	III (IEC 61800-5-1)		
Pollution degree	-	2 (IEC 61800-5-1)		
Motor brake	Output voltage	Control voltage minus 0.8 Vdc		
	Output current	1.2 A (maximum)		
	Inductance	1.0 H (maximum)		
	Energy inductive load	1.2 J (maximum)		
	Overload protection	Yes		
	Short-circuit protection	Yes		
Motor temperature sensor	-	Maximum voltage: 5 V		
		Maximum current: 2.5 mA		
Weight	Weight (without packaging)	3 kg (6.6 lbs)		
	Weight (with packaging)	3.91 kg (8.62 lbs)		
<p>NOTE:</p> <ul style="list-style-type: none"> Lexium 62 Double Drive includes the variant D: LXM62DU60D, LXM62DD15D, LXM62DD27D Lexium 62 Double Drive embedded safety includes the variant F: LXM62DU60F, LXM62DD15F, LXM62DD27F 				

Dimensions - Double Drives

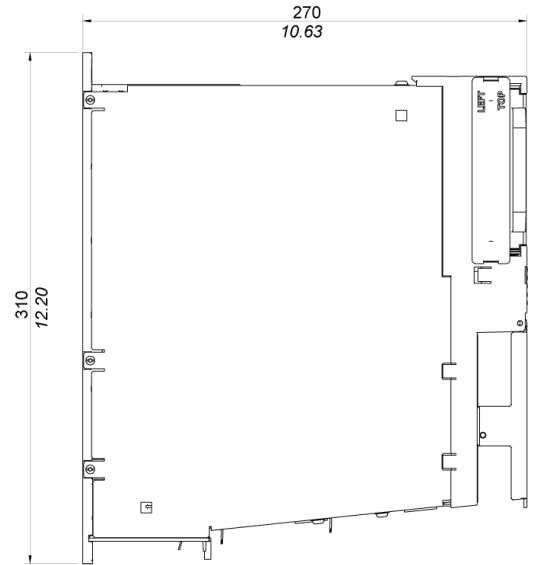
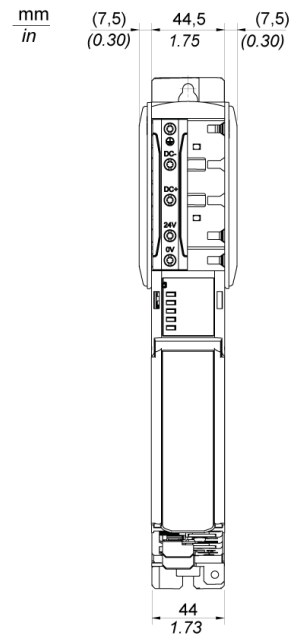

Mechanical and Electrical Data for the Lexium 62 DC Link Terminal

Technical Data for the Lexium 62 DC Link Terminal

Designation	Parameter	Value
Electrical specification	Rated Voltage	1000 Vdc on the Lexium 62 DC Link Terminal connectors for the upper three Bus Bar Module ports. NOTE: The ports of the Bus Bar Module are numbered from top to bottom.
		24 Vdc on the Lexium 62 DC Link Terminal connectors for the bottom two Bus Bar Module ports.
	Rated continuous current	120 A with temperature rise of less than 60 K.
	High voltage test level	2120 Vdc or 1500 Vac between ports 2 and 1 and between ports 3 and 1 of Bus Bar Modules. NOTE: The ports of the Bus Bar Module are numbered from top to bottom.
	System voltage	300 V
Pollution degree	–	2 (IEC 60664-1)
Over voltage category	–	III
Lifetime of end product	–	≥60,000 hours

Dimensions - Lexium 62 DC Link Terminal

Dimensions of the Lexium 62 DC Link Terminal:

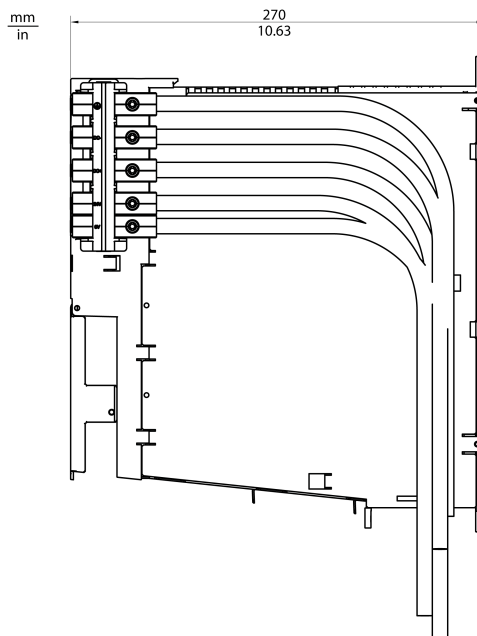

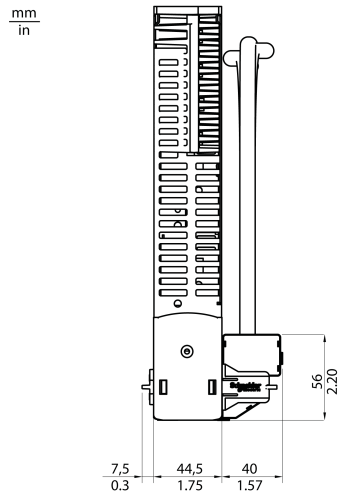
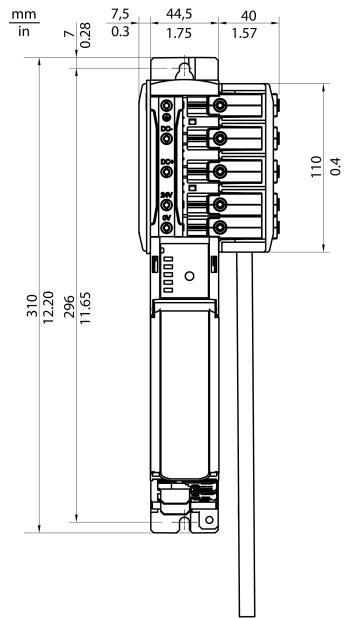

Mechanical and Electrical Data for the Lexium 62 DC Link Support Module

Technical Data for the Lexium 62 DC Link Support Module

Designation	Parameter	Value
Power supply	Control voltage	30 Vdc (maximum)
	DC bus voltage (nominal)	700 Vdc (maximum)
	DC bus capacity	1.76 mF
	Discharge time	5 min (maximum)
	Overvoltage	900 Vdc
Cooling	-	Natural convection
Ingress protection rating	-	IP20
Isolation class	Pollution degree	2 (IEC 60664-1)
Protective class	Class	1 (IEC/EN 61800-5-1)
Overvoltage category	Class	III (IEC/EN 61800-5-1)
Radio interference level	Class	C3 (IEC/EN 61800-3)
Lifetime of end product	-	≥60,000 hours
Weight	Weight (with packaging)	3.1 kg (3.8 kg) / 6.83 lbs (8.38 lbs)

Dimensions - Lexium 62 DC Link Support Module

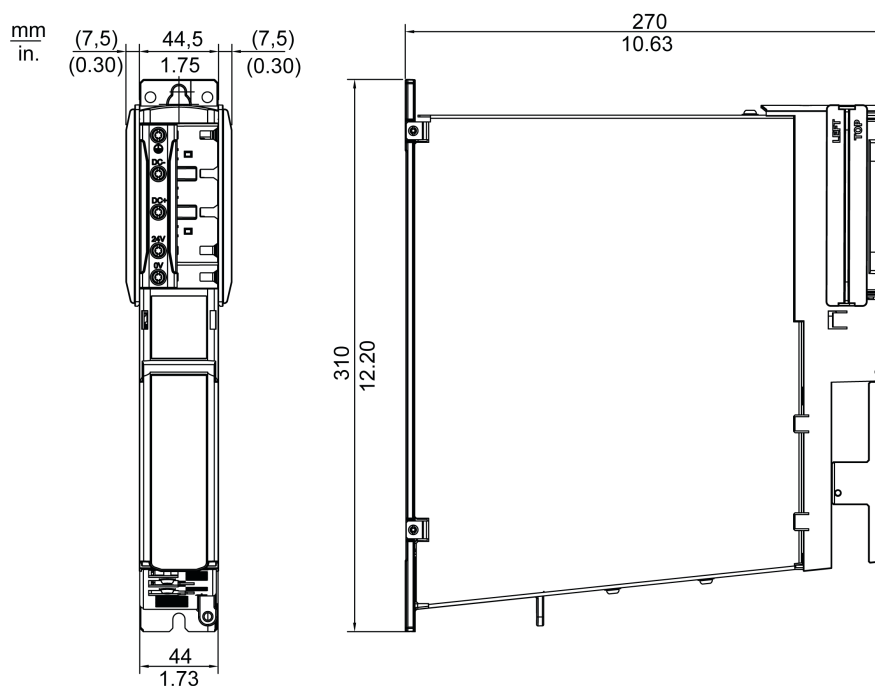

Optional Accessory

5V Encoder Adapter

Overview

General Information

5V Encoder Adapter

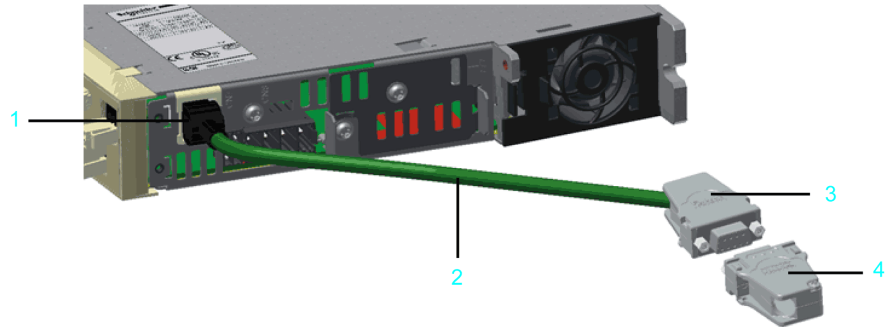

- 1 RJ45 connector
- 2 Encoder cable
- 3 D-Sub 9-pin female connector
- 4 D-Sub 9-pin male connector at the encoder cable (user wired)

Features

The 5V Encoder Adapter consists of an encoder cable (2) with an RJ45 connector (1) on one side that is connected to a Lexium 62 servo drive, and a D-Sub 9-pin female connector (3) on the other side.

A DC/DC converter is assembled in the D-Sub 9-pin female connector (3). It converts the encoder power supply that is coming from the drive from 10 V to 5 V, making it possible to connect 5 V encoders which are not directly supported by the Lexium 62 servo drive. The 5 V and the 10 V encoder supply voltage is available on the D-Sub 9-pin female connector (3). The other signals, such as encoder- and RS485 signals are transferred directly from the drive to the encoder.

NOTICE

CURRENT TOO HIGH AT THE ENCODER CONNECTOR OF THE LEXIUM 62 SERVO DRIVE BY USING BOTH 5 V AND 10 V VOLTAGE SUPPLY

- Use exclusively one voltage supply for the encoder, either 5 V or 10 V.
- In the case of using 5 V encoders, ensure that the maximum power consumption of the encoder does not exceed 250 mA.

Failure to follow these instructions can result in equipment damage.

For further information on the 5V Encoder Adapter, see catalog *Multi axis servo system and servo motors for PacDrive 3*.

Technical Data

Technical Data

Parameter		Value
Item name		VW3E6027
Input voltage		DC 10 V (-5% / +5%)
Maximum input current		125 mA
Output voltage		DC 5 V (-1% / +1%)
Maximum output current		250 mA
Sin/Cos input voltage		1 V _{pp} / 2.5 V offset 0.5 V _{pp} by 100 kHz
Input resistance		120 Ω
Cutoff-frequency		100 MHz (6000 min ⁻¹ x 1024)
Operation	Protection class housing	IP20 with connected plug-in connectors
	Ambient temperature	+5...+55 °C (+41...+131 °F)
	Relative humidity	5...85%
Transport	Ambient temperature	-25...+70 °C (-13...+158 °F)
	Relative humidity	5...95%
Long-term storage in the transport packaging	Ambient temperature	-25...+55 °C (-13...+131 °F)
	Relative humidity	10...95%

Electrical Connections and Dimensions

RJ45 Connector - 5V Encoder Adapter Input

The RJ45 connector is connected to the connection **CN7/CN9** of the drive. Pin assignment of the RJ45 connector is identical to the pin assignment for the connection **CN7/CN9** of the drive, page 161.

D-Sub 9-Pin Female Connector - 5V Encoder Adapter Output

The D-Sub 9-pin female connector is connected to the D-Sub 9-pin male connector of the encoder cable (user wired).

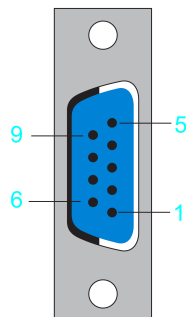

Pin	Designation	Description	Range
1	SIN	Positive sine signal	1 V _{pp} ±0.1 V
2	Ref_Sin	Negative sine signal	Offset 2.5 ±0.3 V
3	COS	Positive cosine signal	1 V _{pp} ±0.1 V
4	Ref_Cos	Negative cosine signal	Offset 2.5 ±0.3 V
5	RS485+	Positive RS-485 signal	-

Pin	Designation	Description	Range
6	P5V	5 V encoder supply voltage	5 V \pm 1% / I_{out_max} =250 mA
7	P10V	10 V encoder supply voltage	10 V \pm 5% / I_{out_max} =125 mA
8	RS485-	Negative RS-485 signal	–
9	GND	Encoder return	0 V

D-Sub 9-Pin Male Connector - Encoder Cable (Assembled by the Customer)

View mating side

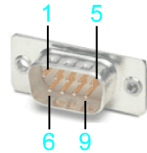

View soldering side

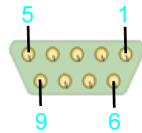

Pin	Designation	Description	Range
1	SIN	Positive sine signal	1 V _{pp} \pm 0.1 V
2	Ref_Sin	Negative sine signal	Offset 2.5 \pm 0.3 V
3	COS	Positive cosine signal	1 V _{pp} \pm 0.1 V
4	Ref_Cos	Negative cosine signal	Offset 2.5 \pm 0.3 V
5	N.C.	Reserved	–
6	P5V	5 V encoder supply voltage	5 V \pm 1% / I_{out_max} =250 mA
7	P10V	10 V encoder supply voltage	10 V \pm 5% / I_{out_max} =125 mA
8	N.C.	Reserved	–
9	GND	Encoder return	0 V

Dimensions

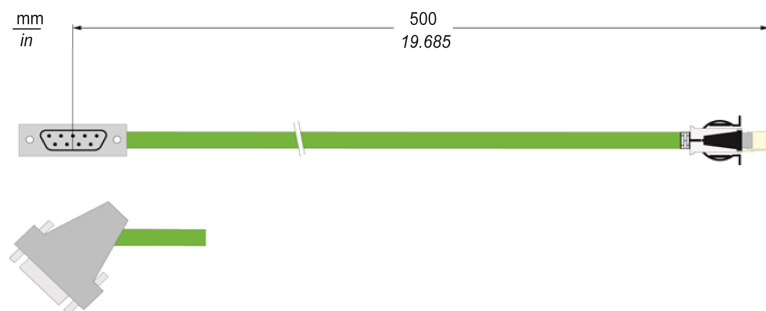

Wiring

Encoder Cable

Connection of D-Sub 9-pin male connectors at the encoder cable (user furnished):

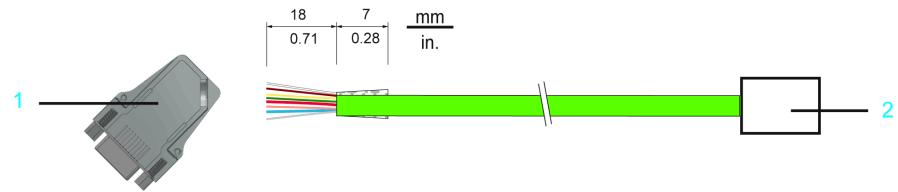

1 D-Sub 9-pin male connector at the encoder cable

2 Encoder connector

Cable configuration of encoder cable

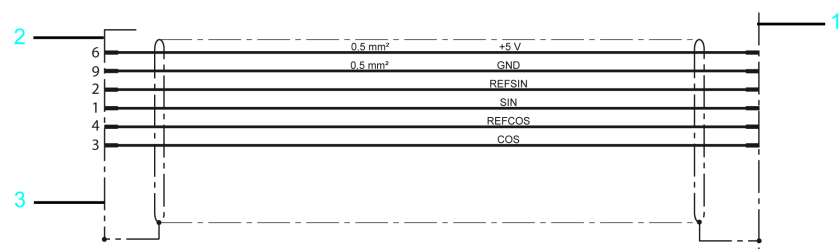

1 Encoder connector

2 D-Sub 9-pin male connector at the encoder cable

3 Metal housing

Maximum encoder cable length

Connection cross section [mm ²] / [AWG]	Current consumption [A]	Maximum encoder cable length [m] / [ft]
0.5 / 20	0.05	58 / 190.3
	0.07	41 / 134.5
	0.10	29 / 95.1
	0.12	24 / 78.7
	0.18	16 / 52.5
	0.24	12 / 39.4

Appendices

What's in This Part

Disposal	190
----------------	-----

Disposal

What's in This Chapter

Disposal	190
----------------	-----

Disposal

Information on the Disposal of Schneider Electric Products

NOTE: The components consist of different materials which can be recycled and must be disposed of separately.

Step	Action
1	Dispose of the packaging in accordance with the relevant national regulations.
2	Dispose of the packaging at the disposal sites provided for this purpose.
3	Dispose of Lexium 62 Devices in accordance with the applicable national regulations.

Glossary

A

AWG:

(*American wire gauge*) The standard that specifies wire section sizes in North America.

C

configuration:

The arrangement and interconnection of hardware components within a system and the hardware and software parameters that determine the operating characteristics of the system.

D

DC bus:

Circuit that supplies the power stage with energy (direct voltage).

Degree of protection:

The degree of protection is a standardized specification for electrical equipment that describes the protection against the ingress of foreign objects and water (for example: IP 20).

DOM:

Date of manufacturing: The nameplate of the product shows the date of manufacture in the format DD.MM.YY or in the format DD.MM.YYYY. For example:

31.12.11 corresponds to December 31, 2011

31.12.2011 corresponds to December 31, 2011

E

EMC:

Electromagnetic compatibility

encoder:

A device for length or angular measurement (linear or rotary encoders).

L

LED:

(*light emitting diode*) An indicator that illuminates under a low-level electrical charge.

P

PELV:

Protective Extra Low Voltage, low voltage with isolation. For more information: IEC 60364-4-41

PE:

(*Protective Earth*) A common grounding connection to help avoid the hazard of electric shock by keeping any exposed conductive surface of a device at earth potential. To avoid possible voltage drop, no current is allowed to flow in this

conductor (also referred to as *protective ground* in North America or as an equipment grounding conductor in the US national electrical code).

Index

B

bending cycles 41

C

certifications 167
climatic 38
condensate 39
cooling units 39
CSA 22.2 45

D

defined safe stop 72
degree of protection 37
domestic appliances 15

E

emergency stop 71

F

floating systems 15

H

hazard and risk analysis 69
hazardous, explosive atmospheres 15

I

installation 78
InverterEnable 72
IP 37

L

life support system 15

M

machine grounding 40
mechanical 38
minimum bending radius 41
minimum cross sections 40
mobile systems 16

O

opto-coupler 72

P

portable systems 16
product related information 10

Q

qualification of personnel 17
qualified person 17

S

standards 98
stop category 0 73
stop category 1 73

T

temperature limit 39
training 17

U

UL / CSA-compliant use 45
underground 15

W

wiring 40

Schneider Electric
35 rue Joseph Monier
92500 Rueil Malmaison
France

+ 33 (0) 1 41 29 70 00

www.se.com

As standards, specifications, and design change from time to time,
please ask for confirmation of the information given in this publication.

© 2021 – Schneider Electric. All rights reserved.

EIO0000003738.02