

# Modicon TM5 EtherNet/IP Fieldbus Interface

## Hardware Guide

EIO0000003715.04  
07/2023



# Legal Information

The information provided in this document contains general descriptions, technical characteristics and/or recommendations related to products/solutions.

This document is not intended as a substitute for a detailed study or operational and site-specific development or schematic plan. It is not to be used for determining suitability or reliability of the products/solutions for specific user applications. It is the duty of any such user to perform or have any professional expert of its choice (integrator, specifier or the like) perform the appropriate and comprehensive risk analysis, evaluation and testing of the products/solutions with respect to the relevant specific application or use thereof.

The Schneider Electric brand and any trademarks of Schneider Electric SE and its subsidiaries referred to in this document are the property of Schneider Electric SE or its subsidiaries. All other brands may be trademarks of their respective owner.

This document and its content are protected under applicable copyright laws and provided for informative use only. No part of this document may be reproduced or transmitted in any form or by any means (electronic, mechanical, photocopying, recording, or otherwise), for any purpose, without the prior written permission of Schneider Electric.

Schneider Electric does not grant any right or license for commercial use of the document or its content, except for a non-exclusive and personal license to consult it on an "as is" basis.

Schneider Electric reserves the right to make changes or updates with respect to or in the content of this document or the format thereof, at any time without notice.

**To the extent permitted by applicable law, no responsibility or liability is assumed by Schneider Electric and its subsidiaries for any errors or omissions in the informational content of this document, as well as any non-intended use or misuse of the content thereof.**

---

# Table of Contents

Safety Information.....	5
QUALIFICATION OF PERSONNEL .....	5
INTENDED USE.....	6
About the Book.....	7
TM5 / TM7 System General Rules for Implementation .....	12
Installation and Maintenance Requirements .....	12
Wiring Best Practices.....	14
TM5 Environmental Characteristics.....	17
Certifications and Standards.....	18
TM5 EtherNet/IP Fieldbus Interface General Overview.....	20
TM5 EtherNet/IP Fieldbus Interface General Description .....	20
TM5 EtherNet/IP Fieldbus Interface Physical Description.....	21
TM5 Expansion Modules General Description.....	22
TM7 Expansion Modules General Description.....	27
First Startup .....	28
TM5 EtherNet/IP Fieldbus Interface.....	30
TM5 EtherNet/IP Fieldbus Interface Presentation.....	30
TM5 EtherNet/IP Fieldbus Interface Characteristics .....	32
Mounting Positions .....	33
Rotary Switch.....	35
Ethernet Port.....	38
Connecting the TM5NEIP1 to a PC .....	40
TM5 Interface Power Distribution Module (IPDM) .....	41
TM5SPS3 Presentation.....	41
TM5SPS3 Characteristics .....	42
TM5SPS3 Wiring Diagram .....	44
Glossary .....	47
Index .....	50



# Safety Information

## Important Information

Read these instructions carefully, and look at the equipment to become familiar with the device before trying to install, operate, service, or maintain it. The following special messages may appear throughout this documentation or on the equipment to warn of potential hazards or to call attention to information that clarifies or simplifies a procedure.





The addition of this symbol to a “Danger” or “Warning” safety label indicates that an electrical hazard exists which will result in personal injury if the instructions are not followed.



This is the safety alert symbol. It is used to alert you to potential personal injury hazards. Obey all safety messages that follow this symbol to avoid possible injury or death.

 <b>DANGER</b>
<b>DANGER</b> indicates a hazardous situation which, if not avoided, <b>will result in</b> death or serious injury.

 <b>WARNING</b>
<b>WARNING</b> indicates a hazardous situation which, if not avoided, <b>could result in</b> death or serious injury.

 <b>CAUTION</b>
<b>CAUTION</b> indicates a hazardous situation which, if not avoided, <b>could result in</b> minor or moderate injury.

<b>NOTICE</b>
<b>NOTICE</b> is used to address practices not related to physical injury.

## Please Note

Electrical equipment should be installed, operated, serviced, and maintained only by qualified personnel. No responsibility is assumed by Schneider Electric for any consequences arising out of the use of this material.

A qualified person is one who has skills and knowledge related to the construction and operation of electrical equipment and its installation, and has received safety training to recognize and avoid the hazards involved.

## QUALIFICATION OF PERSONNEL

Only appropriately trained persons who are familiar with and understand the contents of this manual and all other pertinent product documentation are authorized to work on and with this product.

The qualified person must be able to detect possible hazards that may arise from parameterization, modifying parameter values and generally from mechanical, electrical, or electronic equipment. The qualified person must be familiar with the standards, provisions, and regulations for the prevention of industrial accidents, which they must observe when designing and implementing the system.

---

## INTENDED USE

The products described or affected by this document, together with software, accessories, and options, are fieldbus interfaces, intended for industrial use according to the instructions, directions, examples, and safety information contained in the present document and other supporting documentation.

The product may only be used in compliance with all applicable safety regulations and directives, the specified requirements, and the technical data.

Prior to using the product, you must perform a risk assessment in view of the planned application. Based on the results, the appropriate safety-related measures must be implemented.

Since the product is used as a component in an overall machine or process, you must ensure the safety of persons by means of the design of this overall system.

Operate the product only with the specified cables and accessories. Use only genuine accessories and spare parts.

Any use other than the use explicitly permitted is prohibited and can result in unanticipated hazards.

# About the Book

## Document Scope

This guide describes the hardware implementation of TM5 EtherNet/IP Fieldbus Interface. It provides the parts description, characteristics, wiring diagrams, and installation details for the Modicon TM5 EtherNet/IP Fieldbus Interface.

## Validity Note

This document has been updated for the release of EcoStruxure™ Machine Expert V2.2.

The characteristics that are described in the present document, as well as those described in the documents included in the Related Documents section below, can be found online. To access the information online, go to the Schneider Electric home page [www.se.com/ww/en/download/](http://www.se.com/ww/en/download/).

The characteristics that are described in the present document should be the same as those characteristics that appear online. In line with our policy of constant improvement, we may revise content over time to improve clarity and accuracy. If you see a difference between the document and online information, use the online information as your reference.

For product compliance and environmental information (RoHS, REACH, PEP, EOL, etc.), go to [www.se.com/ww/en/work/support/green-premium/](http://www.se.com/ww/en/work/support/green-premium/).

## Related Documents

Title of Documentation	Reference Number
Modicon TM5 EtherNet/IP Fieldbus Interface - Programming Guide	EIO0000003707 (ENG)
	EIO0000003708 (FRE)
	EIO0000003709 (GER)
	EIO0000003710 (SPA)
	EIO0000003711 (ITA)
	EIO0000003712 (CHS)
Modicon M262 Logic/Motion Controller - Hardware Guide	EIO0000003659 (ENG)
	EIO0000003660 (FRE)
	EIO0000003661 (GER)
	EIO0000003662 (SPA)
	EIO0000003663 (ITA)
	EIO0000003664 (CHS)
	EIO0000003665 (POR)
	EIO0000003666 (TUR)
Modicon M262 Logic/Motion Controller - Programming Guide	EIO0000003651 (ENG)
	EIO0000003652 (FRE)
	EIO0000003653 (GER)
	EIO0000003654 (SPA)
	EIO0000003655 (ITA)
	EIO0000003656 (CHS)
	EIO0000003657 (POR)
	EIO0000003658 (TUR)

Title of Documentation	Reference Number
Modicon M251 Logic Controller Hardware Guide	EIO0000003101 (ENG) EIO0000003102 (FRE) EIO0000003103 (GER) EIO0000003104 (SPA) EIO0000003105 (ITA) EIO0000003106 (CHS)
Modicon M251 Controller - Programming Guide	EIO0000003089 (ENG) EIO0000003090 (FRE) EIO0000003091 (GER) EIO0000003092 (SPA) EIO0000003093 (ITA) EIO0000003094 (CHS)
Modicon M241 Logic Controller Hardware Guide	EIO0000003083 (ENG) EIO0000003084 (FRE) EIO0000003085 (GER) EIO0000003086 (SPA) EIO0000003087 (ITA) EIO0000003088 (CHS)
Modicon M241 Controller - Programming Guide	EIO0000003059 (ENG) EIO0000003060 (FRE) EIO0000003061 (GER) EIO0000003062 (SPA) EIO0000003063 (ITA) EIO0000003064 (CHS)
TM5/TM7 System Planning and Installation Guide	EIO0000003161 (ENG) EIO0000003162 (FRE) EIO0000003163 (GER) EIO0000003164 (SPA) EIO0000003165 (ITA) EIO0000003166 (CHS)



## Product Related Information

### **DANGER**

#### **HAZARD OF ELECTRIC SHOCK, EXPLOSION OR ARC FLASH**

- Disconnect all power from all equipment including connected devices prior to removing any covers or doors, or installing or removing any accessories, hardware, cables, or wires except under the specific conditions specified in the appropriate hardware guide for this equipment.
- Always use a properly rated voltage sensing device to confirm the power is off where and when indicated.
- Replace and secure all covers, accessories, hardware, cables, and wires and confirm that a proper ground connection exists before applying power to the unit.
- Use only the specified voltage when operating this equipment and any associated products.

**Failure to follow these instructions will result in death or serious injury.**

### **DANGER**

#### **POTENTIAL FOR EXPLOSION**

- Only use this equipment in non-hazardous locations, or in locations that comply with Class I, Division 2, Groups A, B, C and D.
- Do not substitute components which would impair compliance to Class I, Division 2.
- Do not connect or disconnect equipment unless power has been removed or the location is known to be non-hazardous.
- Do not use the USB port(s), if so equipped, unless the location is known to be non-hazardous.

**Failure to follow these instructions will result in death or serious injury.**

<b>⚠ WARNING</b>
<p><b>LOSS OF CONTROL</b></p> <ul style="list-style-type: none"> <li>• Perform a Failure Mode and Effects Analysis (FMEA), or equivalent risk analysis, of your application, and apply preventive and detective controls before implementation.</li> <li>• Provide a fallback state for undesired control events or sequences.</li> <li>• Provide separate or redundant control paths wherever required.</li> <li>• Supply appropriate parameters, particularly for limits.</li> <li>• Review the implications of transmission delays and take actions to mitigate them.</li> <li>• Review the implications of communication link interruptions and take actions to mitigate them.</li> <li>• Provide independent paths for control functions (for example, emergency stop, over-limit conditions, and error conditions) according to your risk assessment, and applicable codes and regulations.</li> <li>• Apply local accident prevention and safety regulations and guidelines.<sup>1</sup></li> <li>• Test each implementation of a system for proper operation before placing it into service.</li> </ul> <p><b>Failure to follow these instructions can result in death, serious injury, or equipment damage.</b></p>

<sup>1</sup> For additional information, refer to NEMA ICS 1.1 (latest edition), *Safety Guidelines for the Application, Installation, and Maintenance of Solid State Control* and to NEMA ICS 7.1 (latest edition), *Safety Standards for Construction and Guide for Selection, Installation and Operation of Adjustable-Speed Drive Systems* or their equivalent governing your particular location.

<b>⚠ WARNING</b>
<p><b>UNINTENDED EQUIPMENT OPERATION</b></p> <ul style="list-style-type: none"> <li>• Only use software approved by Schneider Electric for use with this equipment.</li> <li>• Update your application program every time you change the physical hardware configuration.</li> </ul> <p><b>Failure to follow these instructions can result in death, serious injury, or equipment damage.</b></p>

## Terminology Derived from Standards

The technical terms, terminology, symbols and the corresponding descriptions in the information contained herein, or that appear in or on the products themselves, are generally derived from the terms or definitions of international standards.

In the area of functional safety systems, drives and general automation, this may include, but is not limited to, terms such as *safety*, *safety function*, *safe state*, *fault*, *fault reset*, *malfunction*, *failure*, *error*, *error message*, *dangerous*, etc.

Among others, these standards include:

Standard	Description
IEC 61131-2:2007	Programmable controllers, part 2: Equipment requirements and tests.
ISO 13849-1:2023	Safety of machinery: Safety related parts of control systems. General principles for design.
EN 61496-1:2013	Safety of machinery: Electro-sensitive protective equipment. Part 1: General requirements and tests.

Standard	Description
ISO 12100:2010	Safety of machinery - General principles for design - Risk assessment and risk reduction
EN 60204-1:2006	Safety of machinery - Electrical equipment of machines - Part 1: General requirements
ISO 14119:2013	Safety of machinery - Interlocking devices associated with guards - Principles for design and selection
ISO 13850:2015	Safety of machinery - Emergency stop - Principles for design
IEC 62061:2021	Safety of machinery - Functional safety of safety-related electrical, electronic, and electronic programmable control systems
IEC 61508-1:2010	Functional safety of electrical/electronic/programmable electronic safety-related systems: General requirements.
IEC 61508-2:2010	Functional safety of electrical/electronic/programmable electronic safety-related systems: Requirements for electrical/electronic/programmable electronic safety-related systems.
IEC 61508-3:2010	Functional safety of electrical/electronic/programmable electronic safety-related systems: Software requirements.
IEC 61784-3:2021	Industrial communication networks - Profiles - Part 3: Functional safety fieldbuses - General rules and profile definitions.
2006/42/EC	Machinery Directive
2014/30/EU	Electromagnetic Compatibility Directive
2014/35/EU	Low Voltage Directive

In addition, terms used in the present document may tangentially be used as they are derived from other standards such as:

Standard	Description
IEC 60034 series	Rotating electrical machines
IEC 61800 series	Adjustable speed electrical power drive systems
IEC 61158 series	Digital data communications for measurement and control – Fieldbus for use in industrial control systems

Finally, the term *zone of operation* may be used in conjunction with the description of specific hazards, and is defined as it is for a *hazard zone* or *danger zone* in the *Machinery Directive (2006/42/EC)* and *ISO 12100:2010*.

**NOTE:** The aforementioned standards may or may not apply to the specific products cited in the present documentation. For more information concerning the individual standards applicable to the products described herein, see the characteristics tables for those product references.

## Information on Non-Inclusive or Insensitive Terminology

As a responsible, inclusive company, Schneider Electric is constantly updating its communications and products that contain non-inclusive or insensitive terminology. However, despite these efforts, our content may still contain terms that are deemed inappropriate by some customers.

# TM5 / TM7 System General Rules for Implementation

## Introduction

This chapter provides general information to help you implement TM5 / TM7 System in EcoStruxure Machine Expert.

## Installation and Maintenance Requirements

### Before Starting

Read and understand this chapter before beginning the installation of your TM5 System.

The use and application of the information contained herein require expertise in the design and programming of automated control systems. Only you, the user, machine builder or integrator, can be aware of all the conditions and factors present during installation and setup, operation, and maintenance of the machine or process, and can therefore determine the automation and associated equipment and the related safeties and interlocks which can be effectively and properly used. When selecting automation and control equipment, and any other related equipment or software, for a particular application, you must also consider any applicable local, regional or national standards and/or regulations.

Pay particular attention in conforming to any safety information, different electrical requirements, and normative standards that would apply to your machine or process in the use of this equipment.

### **NOTICE**

#### **ELECTROSTATIC DISCHARGE**

- Store all components in their protective packaging until immediately before assembly.
- Never touch exposed conductive parts such as contacts or terminals.

**Failure to follow these instructions can result in equipment damage.**

### Disconnecting Power

All options and modules should be assembled and installed before installing the control system on a mounting rail, onto a mounting plate or in a panel. Remove the control system from its mounting rail, mounting plate or panel before disassembling the equipment.

<b>⚠️⚠️ DANGER</b>
<p><b>HAZARD OF ELECTRIC SHOCK, EXPLOSION OR ARC FLASH</b></p> <ul style="list-style-type: none"> <li>• Disconnect all power from all equipment including connected devices prior to removing any covers or doors, or installing or removing any accessories, hardware, cables, or wires except under the specific conditions specified in the appropriate hardware guide for this equipment.</li> <li>• Always use a properly rated voltage sensing device to confirm the power is off where and when indicated.</li> <li>• Replace and secure all covers, accessories, hardware, cables, and wires and confirm that a proper ground connection exists before applying power to the unit.</li> <li>• Use only the specified voltage when operating this equipment and any associated products.</li> </ul> <p><b>Failure to follow these instructions will result in death or serious injury.</b></p>

## Programming Considerations

<b>⚠️ WARNING</b>
<p><b>UNINTENDED EQUIPMENT OPERATION</b></p> <ul style="list-style-type: none"> <li>• Only use software approved by Schneider Electric for use with this equipment.</li> <li>• Update your application program every time you change the physical hardware configuration.</li> </ul> <p><b>Failure to follow these instructions can result in death, serious injury, or equipment damage.</b></p>

## Operating Environment

<b>⚠️ WARNING</b>
<p><b>UNINTENDED EQUIPMENT OPERATION</b></p> <p>Install and operate this equipment according to the conditions described in the Environmental Characteristics.</p> <p><b>Failure to follow these instructions can result in death, serious injury, or equipment damage.</b></p>

**NOTE:** Individual I/O modules may differ in terms of operating temperature deratings or other important environmental characteristics. For the specific information, refer to the hardware guide for your particular module.

## Installation Considerations

### **⚠ WARNING**

#### **UNINTENDED EQUIPMENT OPERATION**

- Use appropriate safety interlocks where personnel and/or equipment hazards exist.
- Install and operate this equipment in an enclosure appropriately rated for its intended environment and secured by a keyed or tooled locking mechanism.
- Use the sensor and actuator power supplies only for supplying power to the sensors or actuators connected to the module.
- Power line and output circuits must be wired and fused in compliance with local and national regulatory requirements for the rated current and voltage of the particular equipment.
- Do not use this equipment in safety-critical machine functions unless the equipment is otherwise designated as functional safety equipment and conforming to applicable regulations and standards.
- Do not disassemble, repair, or modify this equipment.
- Do not connect any wiring to reserved, unused connections, or to connections designated as No Connection (N.C.).

**Failure to follow these instructions can result in death, serious injury, or equipment damage.**

**NOTE:** JDYX2 or JDYX8 fuse types are UL-recognized and CSA approved.

## Wiring Best Practices

### Introduction

There are several rules that must be followed when wiring the TM5 System.

### Wiring Rules

### **⚡⚠ DANGER**

#### **HAZARD OF ELECTRIC SHOCK, EXPLOSION OR ARC FLASH**

- Disconnect all power from all equipment including connected devices prior to removing any covers or doors, or installing or removing any accessories, hardware, cables, or wires except under the specific conditions specified in the appropriate hardware guide for this equipment.
- Always use a properly rated voltage sensing device to confirm the power is off where and when indicated.
- Replace and secure all covers, accessories, hardware, cables, and wires and confirm that a proper ground connection exists before applying power to the unit.
- Use only the specified voltage when operating this equipment and any associated products.

**Failure to follow these instructions will result in death or serious injury.**

The following rules must be applied when wiring the TM5 System:

- I/O and communication wiring must be kept separate from the power wiring. Route these 2 types of wiring in separate cable ducting.

- Verify that the operating conditions and environment are within the specification values.
- Use proper wire sizes to meet voltage and current requirements.
- Use copper conductors only.
- Use twisted pair, shielded cables for analog, expert, or fast I/O and TM5 bus signals.
- Use twisted pair, shielded cables for encoder, networks and fieldbus (CAN, serial, Ethernet).





Use shielded, properly grounded cables for all analog and high-speed inputs or outputs and communication connections. If you do not use shielded cable for these connections, electromagnetic interference can cause signal degradation. Degraded signals can cause the controller or attached modules and equipment to perform in an unintended manner.

<b>⚠ WARNING</b>	
<b>UNINTENDED EQUIPMENT OPERATION</b>	
<ul style="list-style-type: none"> <li>• Use shielded cables for all fast I/O, analog I/O and communication signals.</li> <li>• Ground cable shields for all analog I/O, fast I/O and communication signals at a single point<sup>1</sup>.</li> <li>• Route communication and I/O cables separately from power cables.</li> </ul>	
<b>Failure to follow these instructions can result in death, serious injury, or equipment damage.</b>	





<sup>1</sup>Multipoint grounding is permissible if connections are made to an equipotential ground plane dimensioned to help avoid cable shield damage in the event of power system short-circuit currents.

Refer to the section Grounding the TM5 System to ground the shielded cables.

This table provides the wire sizes to use with the removable spring terminal blocks (TM5ACTB06, TM5ACTB12, TM5ACTB12PS, TM5ACTB32):

$\frac{\text{mm}}{\text{in.}}$					
	mm <sup>2</sup>	0,08...2,5	0,25...2,5	0,25...1,5	2 x 0,25...2 x 0,75
	AWG	28...14	24...14	24...16	2 x 24...2 x 18

This table provides the wire sizes to use with the TM5ACTB16 terminal blocks:

$\frac{\text{mm}}{\text{in.}}$				
	mm <sup>2</sup>	0,08...1,5	0,25...1,5	0,25...0,75
	AWG	28...16	24...16	24...20

<b>⚠ DANGER</b>	
<b>FIRE HAZARD</b>	
<ul style="list-style-type: none"> <li>• Use only the correct wire sizes for the maximum current capacity of the I/O channels and power supplies.</li> <li>• For relay output (2 A) wiring, use conductors of at least 0.5 mm<sup>2</sup> (AWG 20) with a temperature rating of at least 80 °C (176 °F).</li> <li>• For common conductors of relay output wiring (7 A), or relay output wiring greater than 2 A, use conductors of at least 1.0 mm<sup>2</sup> (AWG 16) with a temperature rating of at least 80 °C (176 °F).</li> </ul>	
<b>Failure to follow these instructions will result in death or serious injury.</b>	

The spring clamp connectors of the terminal block are designed for only one wire or one cable end. Two wires to the same connector must be installed with a double wire cable end to help prevent loosening.

**⚡ ⚠ DANGER**

**LOOSE WIRING CAUSES ELECTRIC SHOCK**

Do not insert more than one wire per connector of the spring terminal blocks unless using a double wire cable end (ferrule).

**Failure to follow these instructions will result in death or serious injury.**

## TM5 Terminal Block

Inserting an incorrect terminal block into the electronic module can cause unintended operation of the application and/or damage the electronic module.

**⚡ ⚠ DANGER**

**ELECTRIC SHOCK OR UNINTENDED EQUIPMENT OPERATION**

Connect the terminal blocks to their designated location.

**Failure to follow these instructions will result in death or serious injury.**

**NOTE:** To help prevent a terminal block from being inserted incorrectly, ensure that each terminal block and electronic module is clearly and uniquely coded.

## TM5 Strain Relief Using Cable Tie

There are 2 methods to reduce the stress on cables:

- The terminal blocks have slots to attach cable ties. A cable tie can be fed through this slot to secure cables and wires to reduce stress between them and the terminal block connections.
- After grounding the TM5 System by means of the grounding plate TM2XMTGB, wires can be bundled and affixed to the grounding plate tabs using wire ties to reduce stress on the cables.

The following table provides the size of the cable tie and presents the two methods to reduce the stress on the cables:

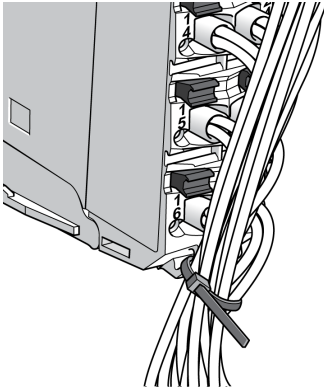
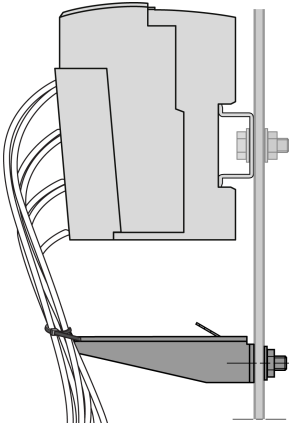
Cable Tie Size	Terminal Block	TM2XMTGB Grounding Plate
Thickness	1.2 mm (0.05 in.) maximum	1.2 mm (0.05 in.)
Width	4 mm (0.16 in.) maximum	2.5...3 mm (0.1...0.12 in.)
Mounting illustration		



<b>▲ WARNING</b>
<p><b>ACCIDENTAL DISCONNECTION FROM PROTECTIVE GROUND (PE)</b></p> <ul style="list-style-type: none"> <li>Do not use the TM2XMTGB Grounding Plate to provide a protective ground (PE).</li> <li>Use the TM2XMTGB Grounding Plate only to provide a functional ground (FE).</li> </ul> <p><b>Failure to follow these instructions can result in death, serious injury, or equipment damage.</b></p>

## TM5 Environmental Characteristics

### Enclosure Requirements

TM5 components are designed as Zone B, Class A industrial equipment according to IEC/CISPR Publication 11. If they are used in environments other than those described in the standard, or in environments that do not meet the specifications in this manual, your ability to meet electromagnetic compatibility requirements in the presence of conducted and/or radiated interference may be reduced.

The TM5 components meet European Community (CE) requirements for open equipment as defined by EN61131-2. You must install them in an enclosure designed for the specific environmental conditions and to minimize the possibility of unintended contact with hazardous voltages. The enclosure should be constructed of metal to improve the electromagnetic immunity of your TM5 System. The enclosure should, and in the case of UL compliance, must, have a keyed locking mechanism to minimize unauthorized access.

### Environmental Characteristics

This equipment meets UL and CSA standards and carry both certification marks. In addition, it is certified as CE compliant. This equipment is intended for use in a Pollution Degree 2 industrial environment.

The table below provides the general environmental characteristics:

Characteristic	Minimum Specification	Tested Range	
Standard	IEC61131-2	-	
Agency Standards	UL 508 CSA 22.2 No. 142-M1987 CSA 22.2 No. 213-M1987	-	
Ambient operating temperature	-	Horizontal installation	-20...60 °C (-4...140 °F)
	-	Vertical installation	-20...50 °C (-4...122 °F)
Storage temperature	-	-40...85 °C (-40...185 °F)	
Relative humidity	-	5...95% (non-condensing)	
Degree of pollution	IEC60664	2	
Degree of protection	IEC61131-2	IP20	
Corrosion immunity	None	-	
Operating altitude	-	0...2000 m (0...6.560 ft.)	
Storage altitude	-	0...3000 m (0...9.842 ft.)	

Characteristic		Minimum Specification	Tested Range
Vibration resistance		IEC/EN 61131-2	Mounted on a DIN rail 3.5 mm (0.138 in.) fixed amplitude from 5...8.4 Hz 9.8 m/s <sup>2</sup> (1 g <sub>n</sub> ) fixed acceleration from 8.4...150 Hz
Mechanical shock resistance		–	147 m/s <sup>2</sup> (15 g <sub>n</sub> ) for a duration of 11 ms
Connection type	Removable spring terminal block	–	–
Connector insertion/removal cycles		–	50
<p><b>NOTE:</b> The tested ranges may indicate values beyond that of the IEC Standard. However, our internal standards define what is necessary for industrial environments. In all cases, we uphold the minimum specification if indicated.</p>			

## Electromagnetic Susceptibility

The following table provides the TM5 System electromagnetic susceptibility specifications:

Characteristic		Minimum Specification	Tested Range
Electrostatic discharge		IEC/EN 61000-4-2	8 kV (air discharge), criteria B 4 kV (contact discharge), criteria B
Electromagnetic fields		IEC/EN 61000-4-3	10 V/m (80 MHz...2 GHz), criteria A
Fast transients burst		IEC/EN 61000-4-4	Power lines: 2 kV, criteria B I/O: 1 kV, criteria B Shielded cable: 1 kV, criteria B Repetition rate: 5 and 100 KHz
Surge immunity 24 Vdc circuit		IEC/EN 61000-4-5	1 kV in common mode, criteria B 0.5 kV in differential mode, criteria B
Surge immunity 230 Vac circuit		IEC/EN 61000-4-5	2 kV in common mode, criteria B 1 kV in differential mode, criteria B
Induced electromagnetic field		IEC/EN 61000-4-6	10 V <sub>eff</sub> (0.15...80 MHz), criteria A
Conducted emission		EN 55011 (IEC/CISPR11)	150...500 kHz, quasi peak 79 dB (μV) 500 kHz...30 MHz, quasi peak 73 dB (μV)
Radiated emission		EN 55011 (IEC/CISPR11)	30...230 MHz, 10 m@40 dB (μV/m) 230 MHz...1 GHz, 10 m@47 dB (μV/m)
<p><b>Criteria A</b> Uninterrupted operation during test.</p> <p><b>Criteria B</b> Brief interruption during the test allowed.</p> <p><b>NOTE:</b> The tested ranges may indicate values beyond that of the IEC Standard. However, our internal standards define what is necessary for industrial environments. In all cases, we uphold the minimum specification if indicated.</p>			

## Certifications and Standards

### Introduction

For information on certifications and conformance to standards, go to [www.se.com](http://www.se.com).

For product compliance and environmental information (RoHS, REACH, PEP, EOL, WEEE, etc.), go to [www.se.com/green-premium](http://www.se.com/green-premium).

# TM5 EtherNet/IP Fieldbus Interface General Overview

## Introduction

This chapter provides a general overview of the TM5 EtherNet/IP Fieldbus Interface.

## TM5 EtherNet/IP Fieldbus Interface General Description

### Introduction

The TM5 EtherNet/IP Fieldbus Interface with built-in power distribution is the first element of the TM5 distributed I/O island. When assembled together, the TM5 EtherNet/IP Fieldbus Interface is composed of four elements:

- Field bus Interface bus base
- Field bus interface module
- Interface Power Distribution Module (IPDM)
- Terminal block

The following figure shows a TM5 EtherNet/IP fieldbus interface when assembled:

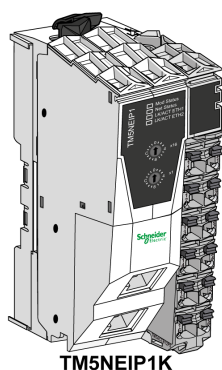

## TM5 EtherNet/IP Field Bus Interface Features

The table below provides the bus base reference:

Reference	Description
TM5ACBN1	Bus base for field bus interface module and Interface Power Distribution Module (IPDM)

The table below provides the field bus interface module references:

Reference	Description
TM5NCO1	CANopen interface module
TM5NEIP1, page 30	EtherNet/IP interface module
TM5NS31	SERCOS III interface module

The table below provides the Interface Power Distribution Module (IPDM) reference:

Reference	Description
TM5SPS3, page 41	Field bus interface 24 Vdc power supply

The table below provides the terminal block reference:

Reference	Description
TM5ACTB12PS	24 Vdc, 12-pin terminal block for PDM, IPDM and Receiver electronic module

## TM5 EtherNet/IP Fieldbus Interface Physical Description

### Introduction

Each fieldbus interface consists of four elements. These elements are the:

- Fieldbus interface bus base
- Fieldbus interface module
- Interface Power Distribution Module (IPDM)
- Terminal block

### Elements

The following figure shows the different parts that compose the TM5 EtherNet/IP Fieldbus Interface:

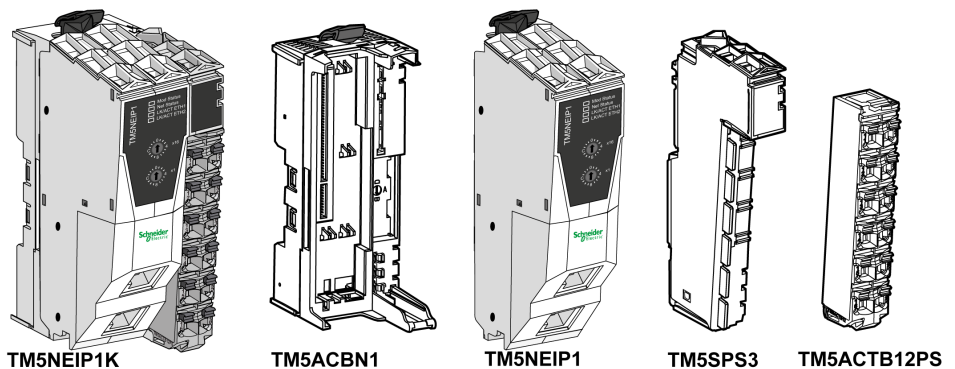

**(TM5NEIP1K)** Fieldbus interface assembly

**(TM5ACBN1)** Fieldbus interface bus base

**(TM5NEIP1)** Fieldbus interface module

**(TM5SPS3)** Interface Power Distribution Module (IPDM)

**(TM5ACTB12PS)** Spring terminal block

## Dimensions

The following figure shows the dimensions of the TM5 EtherNet/IP Fieldbus Interface:

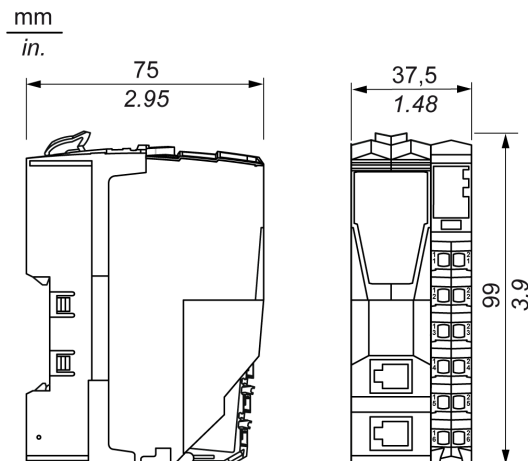

## Accessories

Refer to the Installation of Accessories in the Modicon TM5 / TM7 Flexible System - System Planning and Installation Guide, page 7.

## Labeling

Refer to the Labeling the TM5 System in the Modicon TM5 / TM7 Flexible System - System Planning and Installation Guide, page 7.

# TM5 Expansion Modules General Description

## Introduction

The range of expansion modules includes:

- TM5 Compact I/O modules with integrated electronic modules
- TM5 Digital I/O modules
- TM5 Analog I/O modules
- TM5 Temperature Analog modules
- TM5 Analog Strain modules
- TM5 Expert modules
- TM5 Transmitter - Receiver modules
- TM5 Power distribution modules
- TM5 Common distribution modules
- TM5 Dummy modules

**NOTE:** The listed expansion modules are compatible with the TM5 Fieldbus Interfaces.

The range of TM5 Fieldbus Interfaces includes:

- TM5 EtherNet/IP Fieldbus Interface
- TM5 CANopen Interface

- TM5 Sercos III Interface

Compact, digital, and analog input modules convert measured values (voltages, currents) into numerical values that can be processed by the controller.

Compact, digital, and analog output modules convert controller-internal numerical values into voltages or currents.

Expert modules are used for counting. They use either a Synchronous Serial Interface (SSI) encoder, incremental encoder, or event counting.

The transmitter and receiver modules handle the communication between remote modules via expansion bus cables.

Power distribution modules are used to manage the power supply for the various I/O modules.

Common distribution modules provide 0 Vdc and/or 24 Vdc terminal connections for the 24 Vdc I/O power segment(s) integrated into the bus bases, which expand the wiring possibilities for sensors and actuators.

The dummy module is a non-functional module. This module is used to separate modules which have specific thermal or EMC requirements, or as a placeholder for later system expansion.

The fieldbus interfaces are used to connect TM5 I/O modules and, via the TM5 transmitter module, TM7 I/O modules in a distributed I/O system.

## Compact I/O Expansion Features

Reference	Number of Channels	Voltage/Current
TM5C12D6T6L	12 digital inputs	24 Vdc / 3.75 mA
	6 digital outputs	24 Vdc / 0.5 A
	4 analog inputs	-10...+10 Vdc 0...20 mA/4...20 mA
	2 analog outputs	-10...+10 Vdc 0...20 mA
TM5C12D8T	12 digital inputs	24 Vdc / 3.75 mA
	8 digital outputs	24 Vdc / 0.5 A
TM5C24D12R	24 inputs	24 Vdc / 3.75 mA
	12 relays NO contact	24 Vdc / 230 Vac 2 A
TM5C24D18T	24 digital inputs	24 Vdc / 3.75 mA
	18 digital outputs	24 Vdc / 0.5 A
TM5CAI8O8CL	8 analog inputs	0...20 mA / 4...20 mA
	8 analog outputs	0...20 mA
TM5CAI8O8CVL	4 analog inputs	-10...+10 Vdc
	4 analog inputs	0...20 mA / 4...20 mA
	4 analog outputs	-10...+10 Vdc
	4 analog outputs	0...20 mA
TM5CAI8O8VL	8 analog inputs	-10...+10 Vdc
	8 analog outputs	-10...+10 Vdc

## Digital I/O Expansion Features

Reference	Number of Channels	Voltage/Current
TM5SDI2D	2 inputs	24 Vdc / 3.75 mA
TM5SDI2DF	2 fast inputs	24 Vdc / 10.5 mA
TM5SDI4D	4 inputs	24 Vdc / 3.75 mA
TM5SDI6D	6 inputs	24 Vdc / 3.75 mA
TM5SDI12D	12 inputs	24 Vdc / 3.75 mA
TM5SDI16D	16 inputs	24 Vdc / 2.68 mA
TM5SDI2A	2 inputs	100...240 Vac
TM5SDI4A	4 inputs	100...240 Vac
TM5SDI6U	6 inputs	100...120 Vac
TM5SDO2T	2 outputs	24 Vdc / 0.5 A
TM5SDO4T	4 outputs	24 Vdc / 0.5 A
TM5SDO6T	6 outputs	24 Vdc / 0.5 A
TM5SDO12T	12 outputs	24 Vdc / 0.5 A
TM5SDO16T	16 outputs	24 Vdc / 0.5 A
TM5SDO4TA	4 outputs	24 Vdc / 2 A
TM5SDO8TA	8 outputs	24 Vdc / 2 A
TM5SDO2R	2 relays C/O contact	30 Vdc / 230 Vac 5 A
TM5SDO4R	4 relays NO contact	30 Vdc / 230 Vac 5 A
TM5SDO2S	2 outputs	230 Vac / 1 A
TM5SDM12DT	8 inputs	24 Vdc / 7 mA
	4 outputs	24 Vdc / 0.5 A
TM5SMM6D2L	4 digital inputs	24 Vdc / 3.3 mA
	2 digital outputs	24 Vdc / 0.5 A
	1 analog input	-10...+10 Vdc 0...20 mA / 4...20 mA
	1 analog output	-10...+10 Vdc 0...20 mA

## Analog I/O Expansion Features

Reference	Number of Channels	Voltage/Current
TM5SAI2L	2 inputs	-10...+10 Vdc 0...20 mA / 4...20 mA
TM5SAI4L	4 inputs	-10...+10 Vdc 0...20 mA / 4...20 mA
TM5SAI2H	2 inputs	-10...+10 Vdc 0...20 mA
TM5SAI4H	4 inputs	-10...+10 Vdc 0...20 mA
TM5SAO2L	2 outputs	-10...+10 Vdc 0...20 mA



Reference	Number of Channels	Voltage/Current
TM5SAO2H	2 outputs	-10...+10 Vdc 0...20 mA
TM5SAO4L	4 outputs	-10...+10 Vdc 0...20 mA
TM5SAO4H	4 outputs	-10...+10 Vdc 0...20 mA

## Temperature Analog Expansion Features

Reference	Number of Channels	Sensor Type
TM5SAI2PH	2 inputs	PT100/1000
TM5SAI4PH	4 inputs	PT100/1000
TM5SAI2TH	2 inputs	Thermocouple J, K, N, S
TM5SAI6TH	6 inputs	Thermocouple J, K, N, S

## Analog Strain Gauge Input Electronic Module Features

Reference	Number of Channels	Sensor Type
TM5SEAI5G	1 input	Full-bridge strain gauge

## Expert Expansion Features

Reference	Number of Channels	Encoder Inputs
TM5SE1IC02505	1	5 Vdc Symmetrical
TM5SE1IC01024	1	24 Vdc Asymmetrical
TM5SE2IC01024	2	24 Vdc Asymmetrical
TM5SE1SC10005	1	5 Vdc Symmetrical

## Transmitter-Receiver Expansion Features

Reference	Modules Description
TM5SBET1	TM5 data transmitter electronic module.
TM5SBET7	TM5 data transmitter electronic module. It also distributes power to the TM7 bus.
TM5SBER2	TM5 data receiver electronic module. It also distributes power to the TM5 bus and to the 24 Vdc I/O power segment.

## Power Distribution Expansion Features

Reference	Modules Description
TM5SPS1	24 Vdc I/O power segment supply
TM5SPS1F	24 Vdc I/O power segment supply with integrated fuse
TM5SPS2	24 Vdc I/O power segment supply and TM5 bus supply
TM5SPS2F	24 Vdc I/O power segment supply with integrated fuse and TM5 bus supply
TM5SPS3	FieldBus Interface 24 Vdc power supply

## Common Distribution Expansion Features

Reference	Number of Channels	Voltage
TM5SPDG12F	12	0 Vdc
TM5SPDD12F	12	24 Vdc
TM5SPDG5D4F	2 x 5	0 Vdc - 24 Vdc
TM5SPDG6D6F	2 x 6	0 Vdc - 24 Vdc

## Fieldbus Interface Features

Reference	Port	Communication Type	Terminal Type
TM5NEIP1	2 Ethernet switched ports	EtherNet/IP	RJ45
TM5NS31	2 Ethernet switched ports	Sercos	RJ45
TM5NCO1	-	CANopen	1 SUB-D 9, male

## Dummy Expansion Features

Reference	Number of Channels	Voltage
TM5SD000	-	-

## Match Software and Hardware Configuration

The I/O that may be embedded in your controller is independent of the I/O that you may have added in the form of I/O expansion. It is important that the logical I/O configuration within your program matches the physical I/O configuration of your installation. If you add or remove any physical I/O to or from the I/O expansion bus or, depending on the controller reference, to or from the controller (in the form of cartridges), then you must update your application configuration. This is also true for any field bus devices you may have in your installation. Otherwise, there is the potential that the expansion bus or field bus no longer function while the embedded I/O that may be present in your controller continues to operate.

<b>▲ WARNING</b>
<p><b>UNINTENDED EQUIPMENT OPERATION</b></p> <p>Update the configuration of your program each time you add or delete any type of I/O expansions on your I/O bus, or you add or delete any devices on your field bus.</p> <p><b>Failure to follow these instructions can result in death, serious injury, or equipment damage.</b></p>

## TM7 Expansion Modules General Description

### Introduction

TM5 EtherNet/IP Fieldbus Interface is compatible with TM7 Expansion modules via the TM5 data transmitter electronic module (TM5SBET7).

The range of expansion I/O includes:

- TM7 Digital I/O blocks
- TM7 Analog I/O blocks

Digital or analog input blocks convert measured values (voltages, currents) into numerical values which can be processed by the controller.

Digital or analog output blocks convert controller internal numerical values into voltages or currents.

Analog temperature blocks convert the temperature measurement values into number values which can be processed by the controller. For temperature measurements, the temperature block returns the measured value using 0.1 °C (0.18 °F) steps.

The Power Distribution Blocks PDB are used to manage the power supply for the various I/O blocks. The PDB feeds the TM7 power bus.

**NOTE:** The TM7 I/O blocks are associated with power cables, TM7 bus cables and I/O cables.

### Expansion Block Features

This table lists the digital blocks:

Reference	Number of Channels	Voltage/Current
TM7BDI8B	8 inputs	24 Vdc / 7 mA
TM7BDI16A	16 inputs	24 Vdc / 7 mA
TM7BDI16B	16 inputs	24 Vdc / 7 mA
TM7BDO8TAB	8 outputs	24 Vdc / 2 A
TM7BDM8B <sup>(1)</sup>	8 inputs	24 Vdc / 4.4 mA
	8 outputs	24 Vdc / 0.5 A
TM7BDM16A <sup>(1)</sup>	16 inputs	24 Vdc / 4.4 mA
	16 outputs	24 Vdc / 0.5 A
TM7BDM16B <sup>(1)</sup>	16 inputs	24 Vdc / 4.4 mA
	16 outputs	24 Vdc / 0.5 A
<b>(1)</b> I/O is individually configurable as either input or output.		

This table lists the analog blocks:

Reference	Number of Channels	Voltage/Current
TM7BAI4VLA	4 inputs	-10...+10 Vdc
TM7BAI4CLA	4 inputs	0...20 mA
TM7BAO4VLA	4 outputs	-10...+10 Vdc
TM7BAO4CLA	4 outputs	0...20 mA
TM7BAM4VLA	2 inputs	-10...+10 Vdc
	2 outputs	-10...+10 Vdc
TM7BAM4CLA	2 inputs	0...20 mA
	2 outputs	0...20 mA

This table lists the analog temperature input blocks:

Reference	Number of Channels	Sensor Type
TM7BAI4TLA	4 inputs	PT100/1000
		KTY10-6/84-130
TM7BAI4PLA	4 inputs	Thermocouple J,K,S

## Match Software and Hardware Configuration

The I/O that may be embedded in your controller is independent of the I/O that you may have added in the form of I/O expansion. It is important that the logical I/O configuration within your program matches the physical I/O configuration of your installation. If you add or remove any physical I/O to or from the I/O expansion bus or, depending on the controller reference, to or from the controller (in the form of cartridges), then you must update your application configuration. This is also true for any field bus devices you may have in your installation. Otherwise, there is the potential that the expansion bus or field bus no longer function while the embedded I/O that may be present in your controller continues to operate.

<b>⚠ WARNING</b>
<b>UNINTENDED EQUIPMENT OPERATION</b>
Update the configuration of your program each time you add or delete any type of I/O expansions on your I/O bus, or you add or delete any devices on your field bus.
<b>Failure to follow these instructions can result in death, serious injury, or equipment damage.</b>

## First Startup

### Overview

This procedure helps you through the installation and startup of your TM5 field bus interface.

## Startup Procedure

Step	Action	Comment
1	Unpack your field bus interface module and verify the contents of the package.	Package content: <ul style="list-style-type: none"> <li>• Instruction Sheet</li> <li>• field bus interface module</li> </ul>
2	Unpack: <ul style="list-style-type: none"> <li>• the bus base of your field bus interface</li> <li>• the Interface Power Distribution Module (IPDM)</li> <li>• the terminal block</li> </ul>	For more information, refer to the Physical Description, page 21.
3	Assemble the parts together.	For more information, refer to the Field Bus Interface Installation (see Modicon TM5 / TM7 Flexible System, System Planning and Installation Guide).
4	Choose an appropriate cabinet and DIN rail and install your field bus interface on the DIN rail.	For more information, refer to the DIN Rail Installation and Enclosing the TM5 System (see Modicon TM5 / TM7 Flexible System, System Planning and Installation Guide).
5	Install the expansion modules.	For more information, refer to the Slices Installation or Compact I/O Installation (see Modicon TM5 / TM7 Flexible System, System Planning and Installation Guide).
6	Connect the communication field bus interface	For more information, refer to TM5NEIP1 Wiring Diagram, page 39.
7	Connect your devices to the inputs and outputs.	For more information refer to TM5 Hardware Guides.
8	Connect the external 24 Vdc power source(s) to the Interface Power Distribution Module (IPDM) and any optional Power Distribution Modules (PDM).	For more information, refer to IPDM Wiring Diagram, page 44.
9	Verify all connections.	—

# TM5 EtherNet/IP Fieldbus Interface

## Introduction

This chapter provides a general overview of the Modicon TM5 EtherNet/IP Fieldbus Interface.

## TM5 EtherNet/IP Fieldbus Interface Presentation

### Overview

The TM5 EtherNet/IP Fieldbus Interface is a device designed to manage EtherNet/IP communication.

The main elements are:

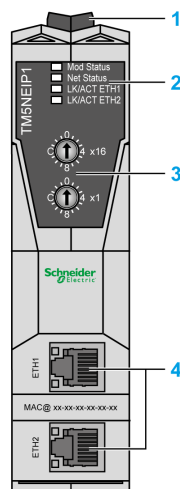

1 Clip-on lock for 35 mm (1.38 in.) top hat section rail (DIN rail)

2 Status LEDs

3 Rotary switches

4 2 RJ45 EtherNet/IP ports

## Main Characteristics

Characteristic	Value
Rated power supply	24 Vdc
Weight	52 g (1.83 oz)
Rotary switch	2
Ethernet	2 isolated switched Ethernet ports (100 Mb / 10 Mb)

**NOTE:** The TM5 EtherNet/IP fieldbus interface supports only a line network topology.

## Distributed Configuration

The following illustration defines a distributed configuration with a controller:

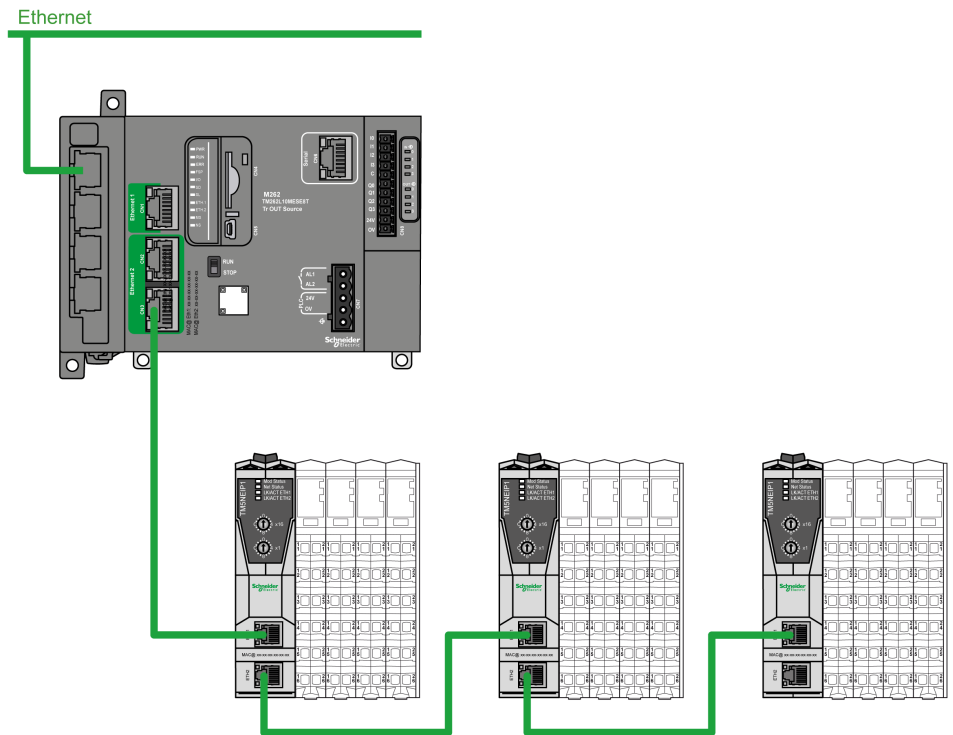

## Status LEDs

The following figure and table provide the TM5NEIP1 IPDM status LEDs:

<input type="checkbox"/>	Mod Status
<input type="checkbox"/>	Net Status
<input type="checkbox"/>	LK/ACT ETH1
<input type="checkbox"/>	LK/ACT ETH2

LED	Color	Status	Description
Mod Status	-	Off	Power is removed.
	Green	On	At least one client is connected.
		Flashing	The TM5 interface is not configured.
		Fast flashing	The TM5 is performing a firmware or configuration upload.
	Red	On	The TM5 interface detected an error that is, in most circumstances, unrecoverable.
		Flashing	The TM5 interface detected an error that is, in most circumstances, recoverable.
Green/Red	Flashing	The TM5 interface is performing a self-test.	
Net Status	-	Off	No Ethernet connection is established.
	Green	On	At least one active master (scanner) connection is established.
		Flashing	No active master (scanner) connection established.
	Red	On	An IP address has been used more than once.
		Flashing	A connection for which the device is the target has timed out.
	Green/Red	Flashing	The TM5 interface is performing a self-test.
LK/ACT ETH1 LK/ACT ETH2	-	Off	No cable connected. No Ethernet connection is established.
	Green	On	An Ethernet connection is established, but no communication exists.
		Flashing	An Ethernet connection is established and communication exists.

## TM5 EtherNet/IP Fieldbus Interface Characteristics

### Introduction

This section provides a general description of the characteristics of the TM5 EtherNet/IP Fieldbus Interface.

<b>⚠ WARNING</b>
<b>UNINTENDED EQUIPMENT OPERATION</b>
Do not exceed any of the rated values specified in the environmental and electrical characteristics tables.
<b>Failure to follow these instructions can result in death, serious injury, or equipment damage.</b>

### General Characteristics

The following table shows the general characteristics for the TM5 EtherNet/IP Fieldbus Interface:

Characteristics	Value
Power consumption	2 W
Cable length	Maximum 100 m (328 ft)
Transfer rate	10/100 Mbit/s



## Dimensions

The following table shows the external dimensions of the TM5 EtherNet/IP Fieldbus Interface:

Characteristics	Dimensions
Width	25 mm (0.98 in)
Height	99 mm (3.89 in)
Depth	75 mm (2.95 in)

## Mounting Positions

### Introduction

This section describes the correct mounting positions for the TM5 EtherNet/IP Fieldbus Interface.

**NOTE:** Keep adequate spacing for proper ventilation and to maintain an ambient temperature as specified in the Environmental Characteristics, page 17.

### Correct Mounting Position

Whenever possible, the TM5 EtherNet/IP Fieldbus Interface should be mounted horizontally on a vertical plane as shown in the figure below:

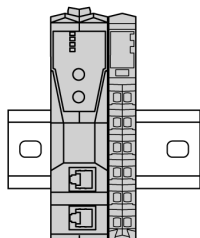

### Acceptable Mounting Position

Whenever possible, the TM5 EtherNet/IP Fieldbus Interface can also be mounted vertically with a temperature derating on a vertical plane as shown below:

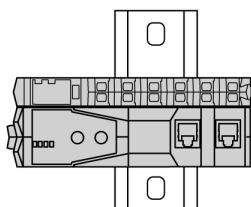

## Incorrect Mounting Position

The figures below show the incorrect mounting positions:

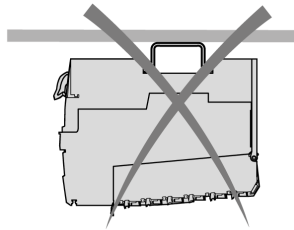
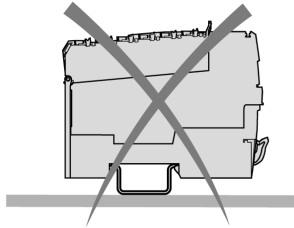
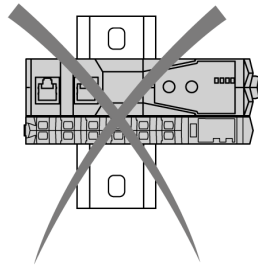

## Mounting the Enclosure

The recommended clearance for the installed enclosures are shown in the figures below:

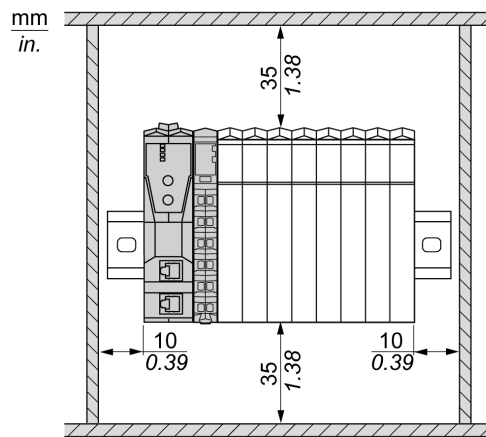

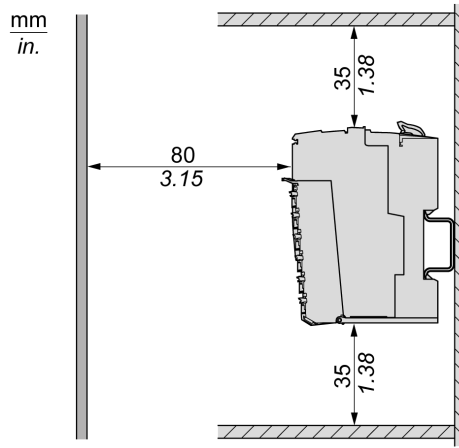

## Rotary Switch

### Overview

The two rotary switches located on the front panel of the TM5 EtherNet/IP Fieldbus Interface are used to set an IP address. By default, the value on the rotary switches is 0.

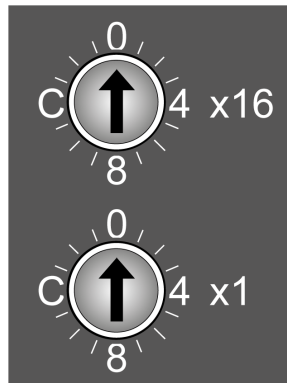

**NOTE:** Any modification of the rotary switch position is taken into account only after the next power cycle.

## Rotary Switch Position Example

The following figure shows an example of the rotary switch position to B5 (hex) = 181 (decimal):

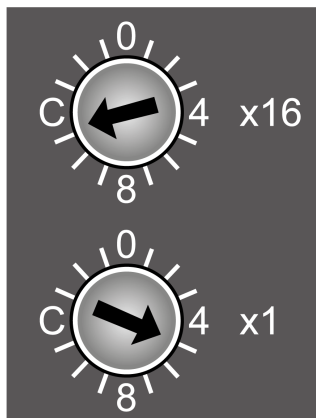

**(x16)** High-order rotary switch: set to B (hex) = 11 (decimal)

**(x1)** Low-order rotary switch: set to 5 (hex) = 5 (decimal)

Rotary switches position value = B5 (hex) =  $11 \times 16 + 1 \times 5 = 181$  (decimal)

## Default Settings

The following table shows the default settings:

Parameter	Value
IP Address	10.10.xxx.xxx <sup>(1)</sup>
Subnet mask	255.0.0.0
Gateway	0.0.0.0
Primary NetBios	-
Secondary NetBios	-

**(1)** The last two fields in the default IP address are composed of the last two hexadecimal bytes of the MAC address of the fieldbus interface.

**NOTE:** A MAC address is always written in hexadecimal format and an IP address in decimal format. Convert the MAC address to decimal format. For example, if the MAC address is 00.80.F4.01.80.F2, the default IP address is 10.10.128.242.

**NOTE:** In case of MAC address ends with 00 hex, the IP address can not be zero in last field, but 128. For example, if the MAC address is 00.80.F4.01.80.00, the default IP address is 10.10.128.128.

**NOTE:** The MAC address value is printed on the front face of the fieldbus interface.

## Setting an IP Address

Set the rotary switches before:

- Applying power to the fieldbus interface.
- Downloading the application.

This table describes the configuration of the rotary switches:

Position of the rotary switches (hex)	Description
00	The IP address stored in flash memory is used.
01...7F	Sets the fieldbus interface to DHCP mode for this range. A device name is generated according to how the network address switches are set.  Generated device name: "TM5NEIP1_" + address switch position.  For example: 1F hex: "TM5NEIP1_31"
80...EF	Sets the fieldbus interface to Fixed IP mode for this range. The IP address is read from the flash memory and the last position of the address is modified with the value of the rotary switches. The address in the flash memory remains unchanged.  For example: Stored IP address: 10.10.34.02, rotary switches: 80 hex => Fixed IP 10.10.34.128
F0	Clears the flash memory, page 37.
F1...FC	Reserved.
FD	Resets all fieldbus interface parameters to default values during booting and reads the Ethernet parameters from the flash memory.
FE	Resets all fieldbus interface parameters to default values during booting. No values are read from flash memory. The Ethernet parameters correspond to the default values.
FF	Resets the Ethernet parameters to default values. The other fieldbus interface parameters are read from flash memory.

Carefully manage the IP addresses because each device on the network requires a unique address. Having multiple devices with the same IP address can cause unintended operation of your network and associated equipment.

⚠ WARNING
UNINTENDED EQUIPMENT OPERATION
<ul style="list-style-type: none"> <li>• Verify that there is only one master controller configured on the network or remote link.</li> <li>• Verify that all devices have unique addresses.</li> <li>• Obtain your IP address from your system administrator.</li> <li>• Confirm that the IP address of the device is unique before placing the system into service.</li> <li>• Do not assign the same IP address to any other equipment on the network.</li> <li>• Update the IP address after cloning any application that includes Ethernet communications to a unique address.</li> </ul> <p><b>Failure to follow these instructions can result in death, serious injury, or equipment damage.</b></p>

**NOTE:** This device comes pre configured with an IP address of 10.10.xxx.xxx. It is good practice to ensure that your system administrator maintains a record of all assigned IP addresses on the network and subnetwork, and to inform the system administrator of all configuration changes performed.

## Clearing the Flash Memory

Step	Action
1	Turn off the power supply to the bus controller.
2	Set the rotary switch position to F0 hex.
3	Turn on the power supply to the bus controller.

Step	Action
4	Wait until the Mod Status LED flashes green for 5 seconds. The rotary switch position must be set first to 00 hex, and then back to F0 hex within this time window of 5 seconds.
5	Wait until the Mod Status LED flashes with a red double-flash (flash memory has been cleared).
6	Turn off the power supply to the bus controller.
7	Set the desired rotary switch position (00 hex - EF hex).
8	Turn on the power supply to the bus controller. <b>Result:</b> The bus controller boots with the configured rotary switch position.

## Applying the IP Address Through DHCP

The DHCP server will provide the IP address to the fieldbus interface. The rotary switch must be set between 01...7F (1...127) to correspond to the DHCP name used for obtaining the IP address.

## Applying the IP Address Manually

Ethernet parameters can be modified in the following ways:

- Using the Web server
- Using the TCP/IP interface object class F5 hex (see Modicon TM5 EtherNet/IP Fieldbus Interface, Programming Guide)

If the IP address is set using the TCP/IP object, the new address is saved to the flash memory if attribute 3 (configuration control) of the TCP/IP object is set to 0.

Changes to attributes in the TCP/IP object are automatically stored to the flash memory. In either case, modified by the Web server or the TCP/IP object, the modified IP address is applied after a power cycle of the fieldbus interface if the position of the rotary switches is set to 00.

## Ethernet Port

### Overview

The TM5NEIP1 is equipped with 2 isolated switched Ethernet ports.

The following figure shows the location of the Ethernet port on the fieldbus interface:

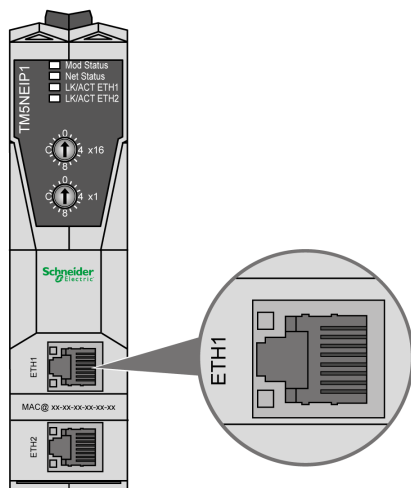

## Characteristics

The following table describes the Ethernet characteristics:

Characteristic	Description
Function	TCP/IP
Connector type	RJ45
Auto negotiation	from 10 M half duplex to 100 M full duplex
Cable type	Shielded
Automatic cross-over detection	Yes

## Pin Assignment

The following figure shows the RJ45 Ethernet connector pin assignment:

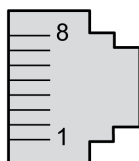

The following table describes the RJ45 Ethernet connector pins:

Pin N°	Signal
1	TD+
2	TD-
3	RD+
4	-
5	-
6	RD-
7	-
8	-

**NOTE:** The fieldbus interface supports the MDI/MDIX auto-crossover cable function. It is not necessary to use special Ethernet crossover cables to connect devices directly to this port (connections without an Ethernet hub or switch).

**NOTE:** Ethernet cable disconnection is detected every second. In case of disconnection of a short duration (< 1 second), the network status may not indicate the disconnection.

## Connecting the TM5NEIP1 to a PC

### Overview

You can connect the TM5NEIP1 to a PC through the Ethernet ports.

### Ethernet Port Connection

To connect the TM5NEIP1 to a PC using the Ethernet ports:

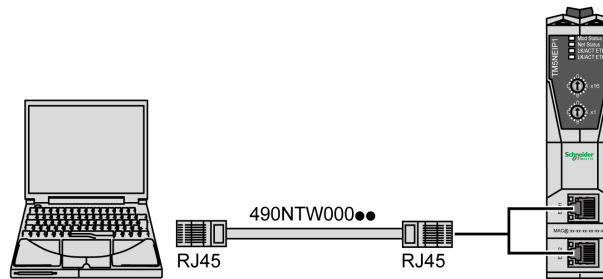

To connect the TM5NEIP1 to the PC, do the following:

Step	Action
1	Connect the Ethernet cable to the PC.
2	Connect the Ethernet cable to one of the Ethernet ports on the TM5NEIP1.
3	Set the rotary switch to the 00 position.
4	Identify the IP address of the fieldbus interface. Example: <ul style="list-style-type: none"> <li>• MAC5 = 80 hex and MAC6 = 37 hex</li> <li>• IP address is 10.10.128.39</li> </ul>
5	Adjust the network adapter settings and set the IP address in same subnet. Example: <ul style="list-style-type: none"> <li>• IP address: 10.10.128.1</li> <li>• Subnet: 255.255.255.0</li> <li>• Gateway: 0.0.0.0</li> </ul>
6	Open <b>CMD</b> window and execute ping command to test the EtherNet/IP communication to the fieldbus interface. If a timeout occurs, go back to step 4. Example: <ul style="list-style-type: none"> <li>• Ping 10.10.128.39 must reply without timeouts</li> </ul>
7	Open a web browser and enter address <b>10.10.128.39</b> to open the Web server. <b>NOTE:</b> The Web Server is disabled by default. To get Web access you need to download a M262 or M241 configuration. The web server can be enabled or disabled in the <b>Configuration Stream</b> tab of the EcoStruxure Machine Expert software. For more details, refer to the Modicon TM5 EtherNet/IP Fieldbus Interface, Programming Guide.



# TM5 Interface Power Distribution Module (IPDM)

## TM5SPS3 Presentation

### Main Characteristics

The TM5SPS3 Interface Power Distribution Module (IPDM) consists of two dedicated electrical circuits:

- A 24 Vdc main power that serves the electronics of the fieldbus interface module and generates independent power for the TM5 power bus that serves the expansion modules.
- A 24 Vdc I/O power segment that serves:
  - The expansion modules
  - The sensors and actuators connected to the expansion modules
  - The external devices connected to the Common Distribution Modules (CDM)

The table below provides the main characteristics of the TM5SPS3 interface power distribution module:

Main characteristics	
Maximum current provided on 24 Vdc I/O power segment	10000 mA
TM5 power bus generated	750 mA

### Ordering Information

The following figure and table provide the references to create a TM5 EtherNet/IP Fieldbus Interface with the TM5SPS3 IPDM:

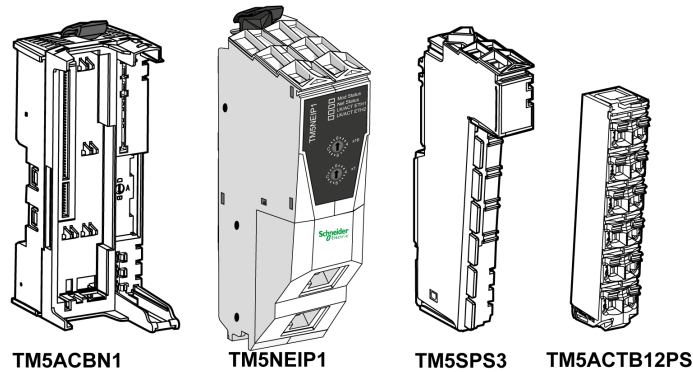

Reference	Description	Color
TM5ACBN1	Bus base 24 Vdc I/O power segment left isolated	White
TM5NEIP1	Fieldbus interface TM5 EtherNet/IP Fieldbus Interface module	White
TM5SPS3	Fieldbus interface 24 Vdc power supply (Interface Power Distribution Module (IPDM))	Grey
TM5ACTB12PS	24 Vdc, 12-pin terminal block for PDM, IPDM, and receiver electronic module	Grey

**NOTE:** For more information, refer to *TM5 Bus Bases and Terminal Blocks*.

## Status LEDs

The following figure and table provide the TM5SPS3 IPDM status LEDs:

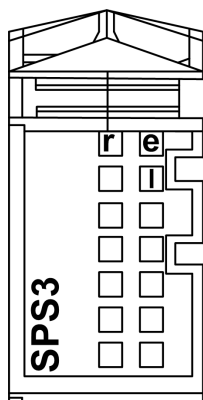

LED	Color	Status	Description
r	Green	Off	Power supply not connected
		Single flash	Reset status
		Flashing	TM5 expansion bus in preoperational status
		On	RUN status
e	Red	Off	OK or module not connected
		Double flash	Indicates one of the following conditions: <ul style="list-style-type: none"> <li>• 24 Vdc I/O power segment, via the external power supply or supplies, is insufficient.</li> <li>• TM5 power bus, via the external power supply or supplies, is insufficient.</li> </ul>
e+r	Steady red/single green flash		Invalid firmware
l	Red	Off	The TM5 interface power distribution module supply is within the acceptable range
		On	The TM5 interface power distribution module supply is insufficient

## TM5SPS3 Characteristics

### General Characteristics

#### **⚠ DANGER**

##### **FIRE HAZARD**

Use only the correct wire sizes for the maximum current capacity of the power supplies.

**Failure to follow these instructions will result in death or serious injury.**

#### **⚠ WARNING**

##### **UNINTENDED EQUIPMENT OPERATION**

Do not exceed any of the rated values specified in the environmental and electrical characteristics tables.

**Failure to follow these instructions can result in death, serious injury, or equipment damage.**

The table below provides the general characteristics of the TM5SPS3:

General Characteristics	
Rated power supply voltage	24 Vdc
24 Vdc I/O power segment current draw	25 mA
Power dissipation	1.82 W maximum
Weight	30 g (1.1 oz)
ID code	8076 dec

See also Environmental Characteristics.

## TM5 Power Bus Characteristics

The table below provides the TM5 power bus characteristics of the TM5SPS3:

TM5 Power Bus Characteristics	
Power supply range	20.4...28.8 Vdc
Rated input current	0.7 A at 24 Vdc
Reverse polarity protection	Yes
Fuse	Integrated, cannot be exchanged
Current generated	<ul style="list-style-type: none"> <li>• On TM5 power bus: 750 mA</li> <li>• To supply the field bus interface module: 300 mA</li> </ul>
Electrical isolation	See note <sup>1</sup>
Parallel operation	Yes <sup>2</sup>
<p><sup>1</sup> The isolation of the electronic module is 500 Vac RMS between the electronics powered by the TM5 bus and those powered by 24 Vdc I/O power segment connected to the module. In practice, the TM5 electronic module is installed in the bus base, and there is a bridge between the TM5 power bus and the 24 Vdc I/O power segment. The two power circuits reference the same functional ground (FE) through specific components designed to reduce effects of electromagnetic interference. These components are rated at 30 Vdc or 60 Vdc. This effectively reduces isolation of the entire system from the 500 Vac RMS.</p> <p><sup>2</sup> In parallel operation, only 75% of the rated power can be assumed. Ensure that all parallel operating power supplies are switched on and off simultaneously.</p>	

## Temperature De-rating

The TM5SPS3 is subject to temperature restrictions depending on the current consumption on the TM5 power bus:

- up to 500 mA: 0...60°C (32...140°F)
- over 500 mA: 0...55°C (32...131°F)

## 24 Vdc I/O Power Segment Characteristics

The table below provides the 24 Vdc I/O power segment characteristics of the TM5SPS3:

24 Vdc I/O Power Segment Characteristics	
Power supply range	20.4...28.8 Vdc
Rated power supply voltage	24 Vdc
Maximum current provided	10 A

24 Vdc I/O Power Segment Characteristics	
Reverse polarity protection	No
Short circuit protection	External fuse type T slow-blow 10 A maximum 250 V
Isolation between power segment and TM5 buses	See note <sup>1</sup>
<sup>1</sup> The isolation of the electronic module is 500 Vac RMS between the electronics powered by the TM5 bus and those powered by 24 Vdc I/O power segment connected to the module. In practice, the TM5 electronic module is installed in the bus base, and there is a bridge between the TM5 power bus and the 24 Vdc I/O power segment. The two power circuits reference the same functional ground (FE) through specific components designed to reduce effects of electromagnetic interference. These components are rated at 30 Vdc or 60 Vdc. This effectively reduces isolation of the entire system from the 500 Vac RMS.	

## TM5SPS3 Wiring Diagram

### Wiring Diagram

The following figure shows the wiring diagram for the TM5SPS3 interface power distribution module:

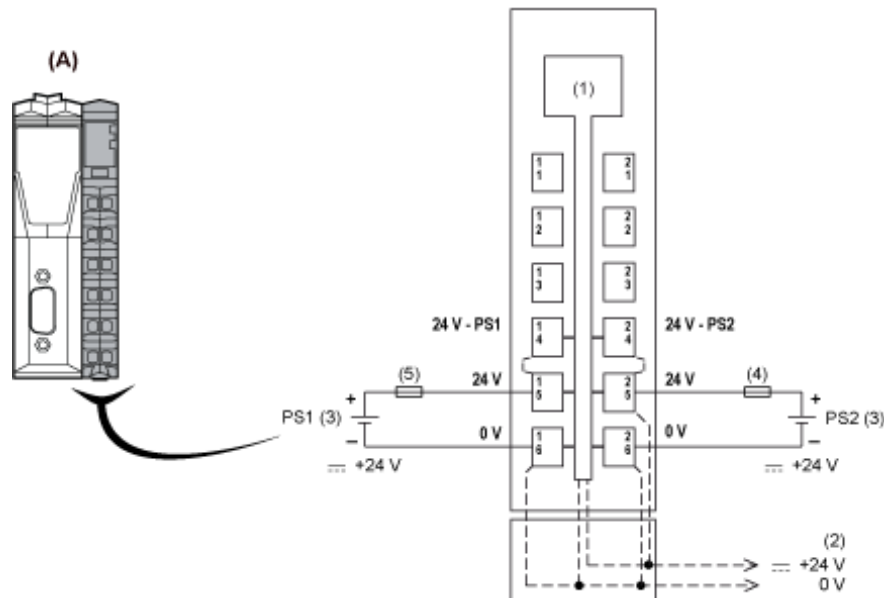

(A) Interface Power Distribution Module (IPDM)

(1) Internal electronics

(2) 24 Vdc I/O power segment integrated in the bus bases

(3) PS1/PS2: External isolated power supply 24 Vdc

(4) External fuse, Type T slow blow, 10 A maximum, 250 V

(5) External fuse, Type T slow blow, 1 A, 250 V

### **▲ WARNING**

#### **POTENTIAL OF OVERHEATING AND FIRE**

- Do not connect the modules directly to line voltage.
- Use only isolating PELV systems according to IEC 61140 to supply power to the modules.

**Failure to follow these instructions can result in death, serious injury, or equipment damage.**

**▲ WARNING**

**UNINTENDED EQUIPMENT OPERATION**

Do not connect wires to unused terminals and/or terminals indicated as “No Connection (N.C.)”.

**Failure to follow these instructions can result in death, serious injury, or equipment damage.**



---

# Glossary

## A

### %:

According to the IEC standard, % is a prefix that identifies internal memory addresses in the logic controller to store the value of program variables, constants, I/O, and so on.

### analog input:

Converts received voltage or current levels into numerical values. You can store and process these values within the logic controller.

### analog output:

Converts numerical values within the logic controller and sends out proportional voltage or current levels.

## C

### CAN:

*(controller area network)* A protocol (ISO 11898) for serial bus networks, designed for the interconnection of smart devices (from multiple manufacturers) in smart systems and for real-time industrial applications. Originally developed for use in automobiles, CAN is now used in a variety of industrial automation control environments.

### compact I/O module:

An inseparable group of 5 analog and/or digital I/O electronic modules in a single reference.

### configuration:

The arrangement and interconnection of hardware components within a system and the hardware and software parameters that determine the operating characteristics of the system.

### control network:

A network containing logic controllers, SCADA systems, PCs, HMI, switches, ...

Two kinds of topologies are supported:

- flat: all modules and devices in this network belong to same subnet.
- 2 levels: the network is split into an operation network and an inter-controller network.

These two networks can be physically independent, but are generally linked by a routing device.

### CSA:

*(Canadian standards association)* The Canadian standard for industrial electronic equipment in hazardous environments.

## D

### digital I/O:

*(digital input/output)* An individual circuit connection at the electronic module that corresponds directly to a data table bit. The data table bit holds the value of the signal at the I/O circuit. It gives the control logic digital access to I/O values.

### DIN:

*(Deutsches Institut für Normung)* A German institution that sets engineering and dimensional standards.

---

## E

### encoder:

A device for length or angular measurement (linear or rotary encoders).

### EN:

EN identifies one of many European standards maintained by CEN (*European Committee for Standardization*), CENELEC (*European Committee for Electrotechnical Standardization*), or ETSI (*European Telecommunications Standards Institute*).

### equipment:

A part of a machine including sub-assemblies such as conveyors, turntables, and so on.

### Ethernet:

A physical and data link layer technology for LANs, also known as IEEE 802.3.

### expansion bus:

An electronic communication bus between expansion I/O modules and a controller or bus coupler.

## F

### FAST I/O:

*FAST input/output* Specific I/O modules with some electrical features (for example, response time) while the treatment of these channels are done directly by the controller

## G

### GVL:

*(global variable list)* Manages global variables within an EcoStruxure Machine Expert project.

## I

### IEC:

*(international electrotechnical commission)* A non-profit and non-governmental international standards organization that prepares and publishes international standards for electrical, electronic, and related technologies.

### I/O:

*(input/output)*

### IP 20:

*(ingress protection)* The protection classification according to IEC 60529 offered by an enclosure, shown by the letter IP and 2 digits. The first digit indicates 2 factors: helping protect persons and for equipment. The second digit indicates helping protect against water. IP 20 devices help protect against electric contact of objects larger than 12.5 mm, but not against water.

### IP 67:

*(ingress protection)* The protection classification according to IEC 60529. IP 67 modules are protected against ingress of dust, contact, and water up to an immersion depth of 1 m.



---

## M

### ms:

*(millisecond)*

## N

### network:

A system of interconnected devices that share a common data path and protocol for communications.

## R

### RJ45:

A standard type of 8-pin connector for network cables defined for Ethernet.

## S

### Sercos:

*(serial real-time communications system)* A digital control bus that interconnects, motion controls, drives, I/Os, sensors, and actuators for numerically controlled machines and systems. It is a standardized and open controller-to-intelligent digital device interface, designed for high-speed serial communication of standardized closed-loop real-time data.

## T

### terminal block:

*(terminal block)* The component that mounts in an electronic module and provides electrical connections between the controller and the field devices.

## U

### UL:

*(underwriters laboratories)* A US organization for product testing and safety certification.

# Index

	TM7 expansion modules general description.....	27
<b>C</b>		
certifications and standards.....		18
characteristics		
TM5ENIP1 Fieldbus Interface .....		32
TM5SPS3.....		42
communication ports		
rotary switch .....		35
Communication Ports		
Ethernet Port .....		38
<b>E</b>		
environmental characteristics .....		17
<b>F</b>		
field bus		
installation .....		28
<b>G</b>		
general description		
TM5 expansion modules.....		22
TM7 expansion modules.....		27
<b>I</b>		
installation		
field bus .....		28
installation and Maintenance		
installation and Maintenance requirements .....		12
intended use .....		6
<b>M</b>		
mounting positions .....		33
<b>P</b>		
presentation		
TM5 EtherNet/IP Fieldbus Interface.....		30
TM5SPS3.....		41
<b>Q</b>		
qualification of personnel .....		5
<b>T</b>		
TM5 .....		12, 20, 30
TM5 EtherNet/IP Fieldbus Interface		
presentation .....		30
TM5 expansion modules		
general description.....		22
TM5NEIP1 Fieldbus Interface		
characteristics .....		32
TM5SPS3		
characteristics .....		42
presentation .....		41
wiring diagram .....		44
TM7 .....		12



Schneider Electric  
35 rue Joseph Monier  
92500 Rueil Malmaison  
France

+ 33 (0) 1 41 29 70 00

[www.se.com](http://www.se.com)

As standards, specifications, and design change from time to time,  
please ask for confirmation of the information given in this publication.

© 2023 Schneider Electric. All rights reserved.

EIO0000003715.04