

Modicon M262 Logic/Motion Controller

Hardware Guide

Original instructions

EIO0000003659.12

04/2026



Legal Information

The information provided in this document contains general descriptions, technical characteristics and/or recommendations related to products/solutions.

This document is not intended as a substitute for a detailed study or operational and site-specific development or schematic plan. It is not to be used for determining suitability or reliability of the products/solutions for specific user applications. It is the duty of any such user to perform or have any professional expert of its choice (integrator, specifier or the like) perform the appropriate and comprehensive risk analysis, evaluation and testing of the products/solutions with respect to the relevant specific application or use thereof.

The Schneider Electric brand and any trademarks of Schneider Electric SE and its subsidiaries referred to in this document are the property of Schneider Electric SE or its subsidiaries. All other brands may be trademarks of their respective owner.

This document and its content are protected under applicable copyright laws and provided for informative use only. No part of this document may be reproduced or transmitted in any form or by any means (electronic, mechanical, photocopying, recording, or otherwise), for any purpose, without the prior written permission of Schneider Electric.

Schneider Electric does not grant any right or license for commercial use of the document or its content, except for a non-exclusive and personal license to consult it on an "as is" basis.

Schneider Electric reserves the right to make changes or updates with respect to or in the content of this document or the format thereof, at any time without notice.

To the extent permitted by applicable law, no responsibility or liability is assumed by Schneider Electric and its subsidiaries for any errors or omissions in the informational content of this document, as well as any non-intended use or misuse of the content thereof.

Table of Contents

Safety Information.....	5
Qualification of Personnel	5
Intended Use.....	6
About the Document.....	7
M262 General Overview	13
M262 General Overview.....	13
M262 Logic/Motion Controller Description.....	13
Maximum Hardware Configuration	17
TM3 Expansion Modules	20
TM3 Bus Couplers	28
TM5 Fieldbus Interfaces	28
TM5 CANopen Fieldbus Interfaces.....	29
TM7 CANopen Fieldbus Interfaces.....	29
TMS Expansion Modules.....	30
Accessories.....	31
M262 Features	32
Real Time Clock (RTC).....	32
Input Management.....	33
Output Management	34
Run/Stop.....	35
SD Card.....	36
Alarm Relay.....	40
M262 Installation	42
M262 Logic/Motion Controller General Rules for Implementing	42
Environmental Characteristics	42
Certifications and Standards.....	44
M262 Logic/Motion Controller Installation	45
Installation and Maintenance Requirements.....	45
M262 Logic/Motion Controller Mounting Positions and Clearances.....	46
Top Hat Section Rail (DIN rail).....	49
Installing and Removing the Controller with Expansions.....	51
Mounting a M262 Logic/Motion Controller on a Panel Surface	53
M262 Electrical Requirements	54
Wiring Best Practices	54
DC Power Supply Characteristics and Wiring	58
Grounding the M262 Logic/Motion Controller System	60
Alarm Relay Wiring	66
Modicon M262 Logic/Motion Controller.....	68
TM262L01MESE8T Presentation	68
TM262L10MESE8T Presentation	73
TM262L20MESE8T Presentation	78
TM262M05MESS8T Presentation.....	83
TM262M15MESS8T Presentation.....	88
TM262M25MESS8T Presentation.....	93
TM262M35MESS8T Presentation.....	98
Embedded I/O Channels	103

Digital Inputs	103
Digital Outputs.....	106
Encoder Interface.....	110
Encoder Interface	110
Integrated Communication Ports.....	115
Ethernet 1 Port	115
Ethernet 2 Ports	117
USB Mini-B Programming Port	119
Serial Line.....	121
Connecting the M262 Logic/Motion Controller to a PC	123
Connecting the Controller to a PC	123
Glossary	125
Index	130

Safety Information

Important Information

Read these instructions carefully, and look at the equipment to become familiar with the device before trying to install, operate, service, or maintain it. The following special messages may appear throughout this documentation or on the equipment to warn of potential hazards or to call attention to information that clarifies or simplifies a procedure.





The addition of this symbol to a "Danger" or "Warning" safety label indicates that an electrical hazard exists which will result in personal injury if the instructions are not followed.



This is the safety alert symbol. It is used to alert you to potential personal injury hazards. Obey all safety messages that follow this symbol to avoid possible injury or death.

 DANGER
DANGER indicates a hazardous situation which, if not avoided, will result in death or serious injury.

 WARNING
WARNING indicates a hazardous situation which, if not avoided, could result in death or serious injury.

 CAUTION
CAUTION indicates a hazardous situation which, if not avoided, could result in minor or moderate injury.

NOTICE
NOTICE is used to address practices not related to physical injury.

Please Note

Electrical equipment should be installed, operated, serviced, and maintained only by qualified personnel. No responsibility is assumed by Schneider Electric for any consequences arising out of the use of this material.

A qualified person is one who has skills and knowledge related to the construction and operation of electrical equipment and its installation, and has received safety training to recognize and avoid the hazards involved.

Qualification of Personnel

Only appropriately trained persons who are familiar with and understand the contents of this manual and all other pertinent product documentation are authorized to work on and with this product.

The qualified person must be able to detect possible hazards that may arise from parameterization, modifying parameter values and generally from mechanical, electrical, or electronic equipment. The qualified person must be familiar with the

standards, provisions, and regulations for the prevention of industrial accidents, which they must observe when designing and implementing the system.

Intended Use

The products described or affected by this document are, together with software, accessories and options, programmable logic controllers (referred to herein as “controllers”), intended for industrial use according to the instructions, directions, examples and safety information contained in the present document and other supporting documentation.

The product may only be used in compliance with all applicable safety regulations and directives, the specified requirements and the technical data.

Prior to using the product, you must perform a risk assessment in view of the planned application. Based on the results, the appropriate safety-related measures must be implemented.

Since the product is used as a component in an overall machine or process, you must ensure the safety of persons by means of the design of this overall system.

Operate the product only with the specified cables and accessories. Use only genuine accessories and spare parts.

Any use other than the use explicitly permitted is prohibited and can result in unanticipated hazards.

About the Document

Document Scope

Use this document to:

- Familiarize yourself with the features of the M262 Logic/Motion Controller.
- Install and operate your M262 Logic/Motion Controller.
- Interface the M262 Logic/Motion Controller with I/O expansion modules and other devices.
- Connect the M262 Logic/Motion Controller to a programming device equipped with EcoStruxure Machine Expert software.

NOTE: Read and understand this document and all related documents, page 10 before installing, operating, or maintaining your controller.

Validity Note

This document has been updated for the release of EcoStruxure™ Machine Expert V2.6.

The characteristics of the products described in this document are intended to match the characteristics that are available on www.se.com. As part of our corporate strategy for constant improvement, we may revise the content over time to enhance clarity and accuracy. If you see a difference between the characteristics in this document and the characteristics on www.se.com, consider www.se.com to contain the latest information.

Product Related Information

⚠️⚠️ DANGER
HAZARD OF ELECTRIC SHOCK, EXPLOSION OR ARC FLASH
<ul style="list-style-type: none">• Disconnect all power from all equipment including connected devices prior to removing any covers or doors, or installing or removing any accessories, hardware, cables, or wires except under the specific conditions specified in the appropriate hardware guide for this equipment.• Always use a properly rated voltage sensing device to confirm the power is off where and when indicated.• Replace and secure all covers, accessories, hardware, cables, and wires and confirm that a proper ground connection exists before applying power to the equipment.• Use only the specified voltage when operating this equipment and any associated products.
Failure to follow these instructions will result in death or serious injury.

⚠ DANGER**POTENTIAL FOR EXPLOSION**

- Only use this equipment in non-hazardous locations, or in locations that comply with Class I, Division 2, Groups A, B, C and D.
- Do not substitute components which would impair compliance to Class I Division 2.
- Do not connect or disconnect equipment unless power has been removed or the location is known to be non-hazardous.

Failure to follow these instructions will result in death or serious injury.

⚠ WARNING**LOSS OF CONTROL**

- Perform a Failure Mode and Effects Analysis (FMEA), or equivalent risk analysis, of your application, and apply preventive and detective controls before implementation.
- Provide a fallback state for undesired control events or sequences.
- Provide separate or redundant control paths wherever required.
- Supply appropriate parameters, particularly for limits.
- Review the implications of transmission delays and take actions to mitigate them.
- Review the implications of communication link interruptions and take actions to mitigate them.
- Provide independent paths for control functions (for example, emergency stop, over-limit conditions, and error conditions) according to your risk assessment, and applicable codes and regulations.
- Apply local accident prevention and safety regulations and guidelines.¹
- Test each implementation of a system for proper operation before placing it into service.

Failure to follow these instructions can result in death, serious injury, or equipment damage.

¹ For additional information, refer to NEMA ICS 1.1 (latest edition), *Safety Guidelines for the Application, Installation, and Maintenance of Solid State Control* and to NEMA ICS 7.1 (latest edition), *Safety Standards for Construction and Guide for Selection, Installation and Operation of Adjustable-Speed Drive Systems* or their equivalent governing your particular location.

⚠ WARNING**UNINTENDED EQUIPMENT OPERATION**

- Only use software approved by Schneider Electric for use with this equipment.
- Update your application program every time you change the physical hardware configuration.

Failure to follow these instructions can result in death, serious injury, or equipment damage.

General Cybersecurity Information

In recent years, the growing number of networked machines and production plants has seen a corresponding increase in the potential for cyber threats, such as unauthorized access, data breaches, and operational disruptions. You must, therefore, consider all possible cybersecurity measures to help protect assets and systems against such threats.

To help keep your Schneider Electric products secure and protected, it is in your best interest to implement the cybersecurity best practices as described in the [Cybersecurity Best Practices](#) document.

Schneider Electric provides additional information and assistance:

- [Subscribe to the Schneider Electric security newsletter.](#)
- [Visit the Cybersecurity Support Portal web page to:](#)
 - [Find Security Notifications.](#)
 - [Report vulnerabilities and incidents.](#)
- [Visit the Schneider Electric Cybersecurity and Data Protection Posture web page to:](#)
 - [Access the cybersecurity posture.](#)
 - [Learn more about cybersecurity in the cybersecurity academy.](#)
 - [Explore the cybersecurity services from Schneider Electric.](#)

Environmental Data

For product compliance and environmental information, refer to the [Schneider Electric Environmental Data Program](#).

Available Languages of the Document

The document is available in these languages:

- [English \(EIO0000003659\)](#)
- [French \(EIO0000003660\)](#)
- [German \(EIO0000003661\)](#)
- [Spanish \(EIO0000003662\)](#)
- [Italian \(EIO0000003663\)](#)
- [Chinese \(EIO0000003664\)](#)

Related Documents

Title of Documentation	Reference Number
Modicon M262 Logic/Motion Controller - Programming Guide	EIO0000003651 (ENG) EIO0000003652 (FRA) EIO0000003653 (GER) EIO0000003654 (SPA) EIO0000003655 (ITA) EIO0000003656 (CHS)
Modicon TM3 Digital I/O Modules - Hardware Guide	EIO0000003125 (ENG) EIO0000003126 (FRE) EIO0000003127 (GER) EIO0000003128 (SPA) EIO0000003129 (ITA) EIO0000003130 (CHS) EIO0000003424 (POR) EIO0000003425 (TUR)
Modicon TM3 Analog I/O Modules - Hardware Guide	EIO0000003131 (ENG) EIO0000003132 (FRE) EIO0000003133 (GER) EIO0000003134 (SPA) EIO0000003135 (ITA) EIO0000003136(CHS) EIO0000003426 (POR) EIO0000003427 (TUR)
Modicon TM3 Expert I/O Modules - Hardware Guide	EIO0000003137 (ENG) EIO0000003138 (FRE) EIO0000003139 (GER) EIO0000003140 (SPA) EIO0000003141 (ITA) EIO0000003142 (CHS) EIO0000003428 (POR) EIO0000003429 (TUR)
Modicon TM3 Safety Modules - Hardware Guide	EIO0000003353 (ENG) EIO0000003354 (FRE) EIO0000003355 (GER) EIO0000003356 (SPA) EIO0000003357 (ITA) EIO0000003358 (CHS) EIO0000003359 (POR) EIO0000003360 (TUR)

Title of Documentation	Reference Number
Modicon TM3 Transmitter and Receiver Modules - Hardware Guide	EIO0000003143 (ENG)
	EIO0000003144 (FRE)
	EIO0000003145 (GER)
	EIO0000003146 (SPA)
	EIO0000003147 (ITA)
	EIO0000003148 (CHS)
	EIO0000003430 (POR)
EIO0000003431 (TUR)	
Modicon TM3 Bus Coupler Module - Hardware Guide	EIO0000003635 (ENG)
	EIO0000003636 (FRE)
	EIO0000003637 (GER)
	EIO0000003638 (SPA)
	EIO0000003639 (ITA)
	EIO0000003640 (CHS)
	EIO0000003641 (POR)
EIO0000003642 (TUR)	
Modicon TM5 Fieldbus Interface - Hardware Guide	EIO0000003715 (ENG)
	EIO0000003716 (FRE)
	EIO0000003717 (GER)
	EIO0000003718 (SPA)
	EIO0000003719 (ITA)
EIO0000003720 (CHS)	
Modicon TMS Expansion Modules - Hardware Guide	EIO0000003699 (ENG)
	EIO0000003700 (FRA)
	EIO0000003701 (GER)
	EIO0000003702 (SPA)
	EIO0000003703 (ITA)
EIO0000003704 (CHS)	
M262 Logic/Motion Controller - Instruction Sheet	QGH55831

To find documents online, visit the Schneider Electric download center (www.se.com/ww/en/download/).

Information on Non-Inclusive or Insensitive Terminology

As a responsible, inclusive company, Schneider Electric is constantly updating its communications and products that contain non-inclusive or insensitive terminology. However, despite these efforts, our content may still contain terms that are deemed inappropriate by some customers.

Terminology Derived from Standards

The technical terms, terminology, symbols and the corresponding descriptions in the information contained herein, or that appear in or on the products themselves, are generally derived from the terms or definitions of international standards.

In the area of functional safety systems, drives and general automation, this may include, but is not limited to, terms such as *safety*, *safety function*, *safe state*, *fault*, *fault reset*, *malfunction*, *failure*, *error*, *error message*, *dangerous*, etc.

Among others, these standards include:

Standard	Description
IEC 61131-2:2007	Programmable controllers, part 2: Equipment requirements and tests.
ISO 13849-1:2023	Safety of machinery: Safety related parts of control systems. General principles for design.
EN 61496-1:2020	Safety of machinery: Electro-sensitive protective equipment. Part 1: General requirements and tests.
ISO 12100:2010	Safety of machinery - General principles for design - Risk assessment and risk reduction
EN 60204-1:2006	Safety of machinery - Electrical equipment of machines - Part 1: General requirements
ISO 14119:2013	Safety of machinery - Interlocking devices associated with guards - Principles for design and selection
ISO 13850:2015	Safety of machinery - Emergency stop - Principles for design
IEC 62061:2021	Safety of machinery - Functional safety of safety-related electrical, electronic, and electronic programmable control systems
IEC 61508-1:2010	Functional safety of electrical/electronic/programmable electronic safety-related systems: General requirements.
IEC 61508-2:2010	Functional safety of electrical/electronic/programmable electronic safety-related systems: Requirements for electrical/electronic/programmable electronic safety-related systems.
IEC 61508-3:2010	Functional safety of electrical/electronic/programmable electronic safety-related systems: Software requirements.
IEC 61784-3:2021	Industrial communication networks - Profiles - Part 3: Functional safety fieldbuses - General rules and profile definitions.
2006/42/EC	Machinery Directive
2014/30/EU	Electromagnetic Compatibility Directive
2014/35/EU	Low Voltage Directive

In addition, terms used in the present document may tangentially be used as they are derived from other standards such as:

Standard	Description
IEC 60034 series	Rotating electrical machines
IEC 61800 series	Adjustable speed electrical power drive systems
IEC 61158 series	Digital data communications for measurement and control – Fieldbus for use in industrial control systems

Finally, the term *zone of operation* may be used in conjunction with the description of specific hazards, and is defined as it is for a *hazard zone* or *danger zone* in the *Machinery Directive (2006/42/EC)* and *ISO 12100:2010*.

NOTE: The aforementioned standards may or may not apply to the specific products cited in the present documentation. For more information concerning the individual standards applicable to the products described herein, see the characteristics tables for those product references.

M262 General Overview

Overview

This chapter provides general information about the M262 Logic/Motion Controller system architecture and its components.

M262 General Overview

M262 Logic/Motion Controller Description

Overview

The M262 Logic/Motion Controller has various powerful features and can service a wide range of applications.

Software configuration, programming, and commissioning are accomplished with the EcoStruxure Machine Expert software, described in detail in the EcoStruxure Machine Expert Programming Guide, as well as the M262 Logic/Motion Controller Programming Guide.

Programming Languages

The M262 Logic/Motion Controller is configured and programmed with the EcoStruxure Machine Expert software which supports the following IEC 61131-3 programming languages:

- IL: Instruction List
- ST: Structured Text
- FBD: Function Block Diagram
- SFC: Sequential Function Chart
- LD: Ladder Diagram

The EcoStruxure Machine Expert software can also be used to program the M262 Logic/Motion Controller using CFC (Continuous Function Chart) language.

Power Supply

The power supply of the M262 Logic/Motion Controller is 24 Vdc, page 58.

Real Time Clock

The M262 Logic/Motion Controller includes a Real Time Clock (RTC) system, page 32.

The system time is maintained by capacitors when the power is off. The time is maintained for 1 000 hours when the controller is not supplied.

Run/Stop

The M262 Logic/Motion Controller can be operated externally by the following:

- A hardware Run/Stop switch, page 35
- A Run/Stop, page 33 operation by a dedicated digital input, defined in the software configuration. For more information, refer to Configuration of Digital Inputs (see Modicon M262 Logic/Motion Controller, Programming Guide).
- A software command
- The system variable PLC_W in a Relocation Table
- The Web server Maintenance: Run/Stop Controller Submenu (see Modicon M262 Logic/Motion Controller, Programming Guide)

Memory

This table describes the different types of memory:

Memory Type	Size	Use
RAM	256 Mbytes, of which 32 Mbytes are available for the application	For the execution of the application and the firmware.
Flash	1 Gbyte	Non-volatile memory dedicated to the retention of the program and data in case of a power interruption.
Non-volatile RAM	512 kbytes	Non-volatile memory dedicated to the retention of the retain-persistent variables, and the diagnostic files and associated information.

Embedded Inputs/Outputs

The following embedded I/O types are available:

- Fast inputs
- Fast source outputs

Encoder

The following encoder modes are available:

- Incremental mode
- SSI mode

Removable Storage

The M262 Logic/Motion Controller includes an integrated SD card slot, page 36.

The main uses of the SD card are:

- Initializing the controller with a new application
- Updating the controller and expansion module firmware (see Modicon M262 Logic/Motion Controller, Programming Guide)
- Applying post configuration files to the controller (see Modicon M262 Logic/Motion Controller, Programming Guide)
- Storing recipes, files
- Receiving data logging files

Embedded Communication Features

The following types of communication ports are available:

- Ethernet, page 117
- USB Mini-B, page 119
- Serial Line, page 121
- Sercos (Ethernet 1), page 116

Expansion Module and Bus Coupler Compatibility

Refer to the compatibility tables in the EcoStruxure Machine Expert Compatibility and Migration User Guide.

Compatibility with Modicon Edge I/O NTS Devices

Refer to the compatibility tables in the EcoStruxure Machine Expert Compatibility and Migration User Guide.

NOTE: To use Modicon Edge I/O NTS devices, you must activate the OPC UA server.

M262 Logic/Motion Controller References

Reference	Digital I/O	Power supply	Communication Ports	Terminal Type	Encoder
M262 Logic Controller: TM262L•	4 fast inputs 4 fast source outputs	24 Vdc	1 serial line port 1 USB programming port 1 Ethernet port 1 dual port Ethernet switch	Removable spring	–
M262 Motion Controller: TM262M•	4 fast inputs 4 fast source outputs	24 Vdc	1 serial line port 1 USB programming port 1 Ethernet port for fieldbus with Sercos interface 1 dual port Ethernet switch	Removable spring	1 Encoder port

NOTE: You can use the fast inputs/outputs as regular inputs/outputs.

Delivery Content

The following figure presents the content of the delivery for the M262 Logic/Motion Controller:

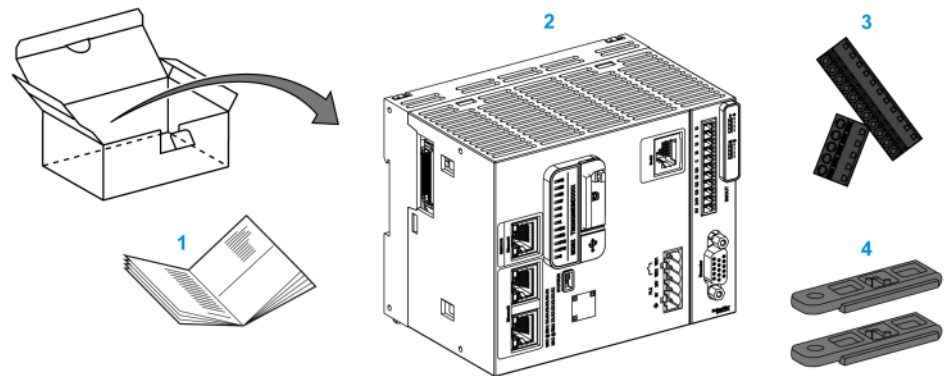

- 1 M262 Logic/Motion Controller Instruction Sheet
- 2 M262 Logic/Motion Controller
- 3 Removable spring terminal blocks
- 4 Attachment parts

Maximum Hardware Configuration

Introduction

The M262 Logic/Motion Controller is a control system that offers an all-in-one solution for motion applications and a scalable solution for logic applications, with optimized configurations and an open, expandable architecture.

Local and Remote Configuration Principle

The following figure defines the local and remote configurations:

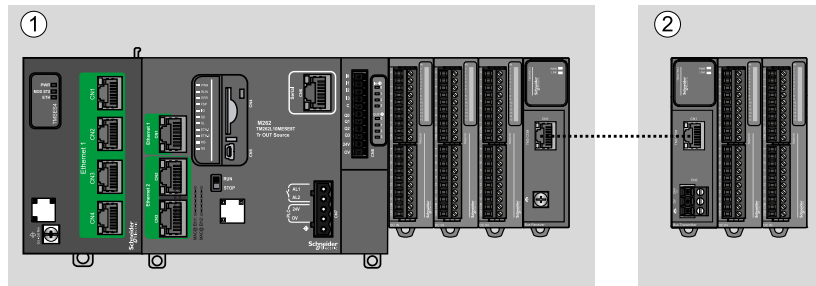

- (1) Local configuration
- (2) Remote configuration

M262 Logic/Motion Controller Local Configuration Architecture

Optimized local configuration and flexibility are provided by the association of:

- M262 Logic/Motion Controller
- TMS expansion modules
- TM3 expansion modules

Application requirements determine the architecture of your M262 Logic/Motion Controller configuration.

The following figure represents the components of a local configuration:

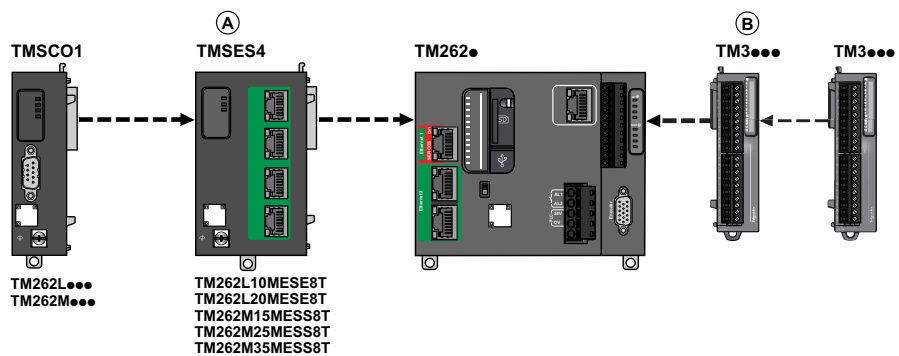

- (A) TMS expansion modules.**
 - 1 TMSCO1 for TM262L01MESE8T and TM262M05MESS8T
 - 3 TMSSES4 or 2 TMSSES4 and 1 TMSCO1 for the other references
 TMSCO1 must be the leftmost module connected to the controller.
- (B) TM3 expansion modules (7 maximum).**

M262 Logic/Motion Controller Remote Configuration Architecture

Optimized remote configuration and flexibility are provided by the association of:

- M262 Logic/Motion Controller
- TMS expansion modules
- TM3 expansion modules
- TM3 transmitter and receiver modules

Application requirements determine the architecture of your M262 Logic/Motion Controller configuration.

The following figure represents the components of a remote configuration:

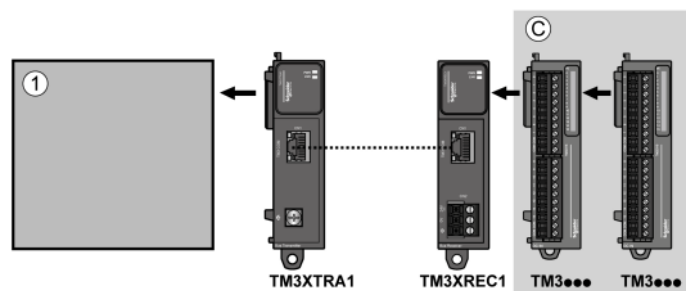

(1) Logic/motion controller and modules

(C) TM3 expansion modules (7 maximum)

M262 Logic/Motion Controller Distributed Configuration Architecture

Optimized remote configuration and flexibility are provided by the association of:

- M262 Logic/Motion Controller
- TM3 bus couplers, page 28
- TM5 fieldbus interface, page 28

This figure shows the components of a distributed architecture:

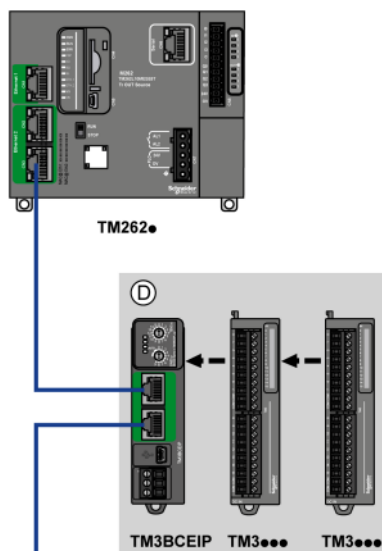

(D) TM3 distributed modules

Maximum Number of Modules

The following table shows the maximum configuration supported:

References	Maximum	Type of Configuration
TM262L01MESE8T TM262M05MESS8T	7 TM3 expansion modules 1 TMSCO1	Local
TM262L10MESE8T TM262M15MESS8T TM262L20MESE8T TM262M25MESS8T TM262M35MESS8T	7 TM3 expansion modules 3 TMS expansion modules composed of: <ul style="list-style-type: none"> up to 3 TMSES4 up to 1 TMSCO1 	Local
TM3XREC1	7 TM3 expansion modules	Remote
TM3BCEIP TM3BCSL TM3BCCO	7 TM3 expansion modules without transmitter and receiver 14 TM3 expansion modules with transmitter and receiver	Distributed
<p>NOTE: TM3 transmitter and receiver modules are not included in a count of the maximum number of expansion modules.</p>		

NOTE: The configuration with its TMS and TM3 expansion modules is validated by the software in the **Configuration** window.

NOTE: In some environments, the maximum configuration populated by high power consumption modules, coupled with the maximum distance allowable between the TM3 transmitter and receiver modules, may present bus communication issues although the software allows for the configuration. In such a case you will need to analyze the power consumption of the modules chosen for your configuration, as well as the minimum cable distance required by your application, and possibly seek to optimize your choices.

TM3 Expansion Modules

Introduction

The range of TM3 expansion modules includes:

- Digital modules, classified as follows:
 - Input modules, page 20
 - Output modules, page 21
 - Mixed input/output modules, page 22
- Analog modules, classified as follows:
 - Input modules, page 23
 - Output modules, page 24
 - Mixed input/output modules, page 25
- Expert modules, page 26
- Safety modules, page 27
- Transmitter and Receiver modules, page 28

For more information, refer to the following documents:

- TM3 Digital I/O Modules Hardware Guide
- TM3 Analog I/O Modules Hardware Guide
- TM3 Expert I/O Modules Hardware Guide
- TM3 Safety Modules Hardware Guide
- TM3 Transmitter and Receiver Modules Hardware Guide

TM3 Digital Input Modules

The following table shows the TM3 digital input expansion modules, with corresponding channel type, nominal voltage/current, and terminal type:

Reference	Channels	Channel Type	Voltage Current	Terminal Type / Pitch
TM3DI8A	8	Regular inputs	120 Vac 7.5 mA	Removable screw terminal block / 5.08 mm
TM3DI8	8	Regular inputs	24 Vdc 7 mA	Removable screw terminal block / 5.08 mm
TM3DI8G	8	Regular inputs	24 Vdc 7 mA	Removable spring terminal block / 5.08 mm
TM3DI16	16	Regular inputs	24 Vdc 7 mA	Removable screw terminal blocks / 3.81 mm
TM3DI16G	16	Regular inputs	24 Vdc 7 mA	Removable spring terminal blocks / 3.81 mm
TM3DI16K	16	Regular inputs	24 Vdc 5 mA	HE10 (MIL 20) connector
TM3DI32K	32	Regular inputs	24 Vdc 5 mA	HE10 (MIL 20) connector

TM3 Digital Output Modules

The following table shows the TM3 digital output expansion modules, with corresponding channel type, nominal voltage/current, and terminal type:

Reference	Channels	Channel Type	Voltage Current	Terminal Type / Pitch
TM3DQ8R	8	Relay outputs	24 Vdc / 240 Vac 7 A maximum per common line / 2 A maximum per output	Removable screw terminal block / 5.08 mm
TM3DQ8RG	8	Relay outputs	24 Vdc / 240 Vac 7 A maximum per common line / 2 A maximum per output	Removable spring terminal block / 5.08 mm
TM3DQ8T	8	Regular transistor outputs (source)	24 Vdc 4 A maximum per common line / 0.5 A maximum per output	Removable screw terminal block / 5.08 mm
TM3DQ8TG	8	Regular transistor outputs (source)	24 Vdc 4 A maximum per common line / 0.5 A maximum per output	Removable spring terminal block / 5.08 mm
TM3DQ8U	8	Regular transistor outputs (sink)	24 Vdc 4 A maximum per common line / 0.5 A maximum per output	Removable screw terminal block / 5.08 mm
TM3DQ8UG	8	Regular transistor outputs (sink)	24 Vdc 4 A maximum per common line / 0.5 A maximum per output	Removable spring terminal block / 5.08 mm
TM3DQ16R	16	Relay outputs	24 Vdc / 240 Vac 8 A maximum per common line / 2 A maximum per output	Removable screw terminal blocks / 3.81 mm
TM3DQ16RG	16	Relay outputs	24 Vdc / 240 Vac 8 A maximum per common line / 2 A maximum per output	Removable spring terminal blocks / 3.81 mm
TM3DQ16T	16	Regular transistor outputs (source)	24 Vdc 8 A maximum per common line / 0.5 A maximum per output	Removable screw terminal blocks / 3.81 mm
TM3DQ16TG	16	Regular transistor outputs (source)	24 Vdc 8 A maximum per common line / 0.5 A maximum per output	Removable spring terminal blocks / 3.81 mm
TM3DQ16U	16	Regular transistor outputs (sink)	24 Vdc 8 A maximum per common line / 0.5 A maximum per output	Removable screw terminal blocks / 3.81 mm
TM3DQ16UG	16	Regular transistor outputs (sink)	24 Vdc 8 A maximum per common line / 0.5 A maximum per output	Removable spring terminal blocks / 3.81 mm
TM3DQ16TK	16	Regular transistor outputs (source)	24 Vdc 2 A maximum per common line / 0.1 A maximum per output	HE10 (MIL 20) connector
TM3DQ16UK	16	Regular transistor outputs (sink)	24 Vdc 2 A maximum per common line / 0.1 A maximum per output	HE10 (MIL 20) connector

Reference	Channels	Channel Type	Voltage Current	Terminal Type / Pitch
TM3DQ32TK	32	Regular transistor outputs (source)	24 Vdc 2 A maximum per common line / 0.1 A maximum per output	HE10 (MIL 20) connectors
TM3DQ32UK	32	Regular transistor outputs (sink)	24 Vdc 2 A maximum per common line / 0.1 A maximum per output	HE10 (MIL 20) connectors

TM3 Digital Mixed Input/Output Modules

This following table shows the TM3 mixed I/O modules, with corresponding channel type, nominal voltage/current, and terminal type:

Reference	Channels	Channel Type	Voltage Current	Terminal Type / Pitch
TM3DM8R	4	Regular inputs	24 Vdc 7 mA	Removable screw terminal block / 5.08 mm
	4	Relay outputs	24 Vdc / 240 Vac 7 A maximum per common line / 2 A maximum per output	
TM3DM8RG	4	Regular inputs	24 Vdc 7 mA	Removable spring terminal block / 5.08 mm
	4	Relay outputs	24 Vdc / 240 Vac 7 A maximum per common line / 2 A maximum per output	
TM3DM16R ⁽¹⁾	8	Regular inputs	24 Vdc 5 mA	Removable screw terminal block / 3.81 mm
	8	Relay outputs	24 Vdc / 240 Vac 4 A maximum per common line / 2 A maximum per output	
TM3DM24R	16	Regular inputs	24 Vdc 7 mA	Removable screw terminal block / 3.81 mm
	8	Relay outputs	24 Vdc / 240 Vac 7 A maximum per common line / 2 A maximum per output	
TM3DM24RG	16	Regular inputs	24 Vdc 7 mA	Removable spring terminal block / 3.81 mm
	8	Relay outputs	24 Vdc / 240 Vac 7 A maximum per common line / 2 A maximum per output	
TM3DM32R ⁽¹⁾	16	Regular inputs	24 Vdc 5 mA	Removable screw terminal block / 3.81 mm
	16	Relay outputs	24 Vdc / 240 Vac 4 A maximum per common line / 2 A maximum per output	

⁽¹⁾ This expansion module is available only in selected countries.

TM3 Analog Input Modules

The following table shows the TM3 analog input expansion modules, with corresponding resolution, channel type, nominal voltage/current, and terminal type:

Reference	Resolution	Channels	Channel Type	Mode	Terminal Type / Pitch
TM3AI2H	16 bit, or 15 bit + sign	2	inputs	0...10 Vdc -10...+10 Vdc 0...20 mA 4...20 mA	Removable screw terminal block / 5.08 mm
TM3AI2HG	16 bit, or 15 bit + sign	2	inputs	0...10 Vdc -10...+10 Vdc 0...20 mA 4...20 mA	Removable spring terminal block / 5.08 mm
TM3AI4	12 bit, or 11 bit + sign	4	inputs	0...10 Vdc -10...+10 Vdc 0...20 mA 4...20 mA	Removable screw terminal block / 3.81 mm
TM3AI4G	12 bit, or 11 bit + sign	4	inputs	0...10 Vdc -10...+10 Vdc 0...20 mA 4...20 mA	Removable spring terminal blocks / 3.81 mm
TM3AI8	12 bit, or 11 bit + sign	8	inputs	0...10 Vdc -10...+10 Vdc 0...20 mA 4...20 mA 0...20 mA extended 4...20 mA extended	Removable screw terminal block / 3.81 mm
TM3AI8G	12 bit, or 11 bit + sign	8	inputs	0...10 Vdc -10...+10 Vdc 0...20 mA 4...20 mA 0...20 mA extended 4...20 mA extended	Removable spring terminal blocks / 3.81 mm
TM3TI4	16 bit, or 15 bit + sign	4	inputs	0...10 Vdc -10...+10 Vdc 0...20 mA 4...20 mA Thermocouple PT100/1000 NI100/1000	Removable screw terminal block / 3.81 mm

Reference	Resolution	Channels	Channel Type	Mode	Terminal Type / Pitch
TM3TI4G	16 bit, or 15 bit + sign	4	inputs	0...10 Vdc -10...+10 Vdc 0...20 mA 4...20 mA Thermocouple PT100/1000 NI100/1000	Removable spring terminal blocks / 3.81 mm
TM3TI4D	16 bit, or 15 bit + sign	4	inputs	Thermocouple	Removable screw terminal block / 3.81 mm
TM3TI4DG	16 bit, or 15 bit + sign	4	inputs	Thermocouple	Removable spring terminal blocks / 3.81 mm
TM3TI8T	16 bit, or 15 bit + sign	8	inputs	Thermocouple NTC/PTC Ohmmeter	Removable screw terminal block / 3.81 mm
TM3TI8TG	16 bit, or 15 bit + sign	8	inputs	Thermocouple NTC/PTC Ohmmeter	Removable spring terminal blocks / 3.81 mm

TM3 Analog Output Modules

The following table shows the TM3 analog output modules, with corresponding resolution, channel type, nominal voltage/current, and terminal type:

Reference	Resolution	Channels	Channel Type	Mode	Terminal Type / Pitch
TM3AQ2	12 bit, or 11 bit + sign	2	outputs	0...10 Vdc -10...+10 Vdc 0...20 mA 4...20 mA	Removable screw terminal block / 5.08 mm
TM3AQ2G	12 bit, or 11 bit + sign	2	outputs	0...10 Vdc -10...+10 Vdc 0...20 mA 4...20 mA	Removable spring terminal block / 5.08 mm
TM3AQ4	12 bit, or 11 bit + sign	4	outputs	0...10 Vdc -10...+10 Vdc 0...20 mA 4...20 mA	Removable screw terminal block / 5.08 mm
TM3AQ4G	12 bit, or 11 bit + sign	4	outputs	0...10 Vdc -10...+10 Vdc 0...20 mA 4...20 mA	Removable spring terminal block / 5.08 mm

TM3 Analog Mixed Input/Output Modules

This following table shows the TM3 analog mixed I/O modules, with corresponding resolution, channel type, nominal voltage/current, and terminal type:

Reference	Resolution	Channels	Channel Type	Mode	Terminal Type / Pitch
TM3AM6	12 bit, or 11 bit + sign	4	inputs	0...10 Vdc	Removable screw terminal block / 3.81 mm
		2	outputs	-10...+10 Vdc 0...20 mA 4...20 mA	
TM3AM6G	12 bit, or 11 bit + sign	4	inputs	0...10 Vdc	Removable spring terminal block / 3.81 mm
		2	outputs	-10...+10 Vdc 0...20 mA 4...20 mA	
TM3TM3	16 bit, or 15 bit + sign	2	inputs	0...10 Vdc -10...+10 Vdc 0...20 mA 4...20 mA Thermocouple PT100/1000 NI100/1000	Removable screw terminal block / 5.08 mm
	12 bit, or 11 bit + sign	1	outputs	0...10 Vdc -10...+10 Vdc 0...20 mA 4...20 mA	
TM3TM3G	16 bit, or 15 bit + sign	2	inputs	0...10 Vdc -10...+10 Vdc 0...20 mA 4...20 mA Thermocouple PT100/1000 NI100/1000	Removable spring terminal block / 5.08 mm
	12 bit, or 11 bit + sign	1	outputs	0...10 Vdc -10...+10 Vdc 0...20 mA 4...20 mA	

TM3 Expert Modules

The following table shows the TM3 expert expansion modules, with corresponding terminal types:

Reference	Description	Terminal Type / Pitch
TM3XTYS4	TeSys module	4 front connectors RJ-45 1 removable power supply connector / 5.08 mm
TM3XFHSC202	High Speed Counting (HSC) module with events	Removable screw terminal blocks / 3.81 mm
TM3XFHSC202G	High Speed Counting (HSC) module with events	Removable spring terminal blocks / 3.81 mm
TM3XHSC202	High Speed Counting (HSC) module	Removable screw terminal blocks / 3.81 mm
TM3XHSC202G	High Speed Counting (HSC) module	Removable spring terminal blocks / 3.81 mm

TM3 Safety Modules

This table contains the TM3 safety modules, with the corresponding channel type, nominal voltage/current, and terminal type:

Reference	Function Category	Channels	Channel type	Voltage Current	Terminal type
TM3SAC5R	1 function, up to category 3	1 or 2 ⁽¹⁾	Safety input	24 Vdc	3.81 mm (0.15 in.) and 5.08 mm (0.20 in.), removable screw terminal block
		Start ⁽²⁾	Input	100 mA maximum	
		3 in parallel	Relay outputs Normally open	24 Vdc / 230 Vac 6 A maximum per output	
TM3SAC5RG	1 function, up to category 3	1 or 2 ⁽¹⁾	Safety input	24 Vdc	3.81 mm (0.15 in.) and 5.08 mm (0.20 in.), removable spring terminal block
		Start ⁽²⁾	Input	100 mA maximum	
		3 in parallel	Relay outputs Normally open	24 Vdc / 230 Vac 6 A maximum per output	
TM3SAF5R	1 function, up to category 4	2 ⁽¹⁾	Safety inputs	24 Vdc	3.81 mm (0.15 in.) and 5.08 mm (0.20 in.), removable screw terminal block
		Start	Input	100 mA maximum	
		3 in parallel	Relay outputs Normally open	24 Vdc / 230 Vac 6 A maximum per output	
TM3SAF5RG	1 function, up to category 4	2 ⁽¹⁾	Safety inputs	24 Vdc	3.81 mm (0.15 in.) and 5.08 mm (0.20 in.), removable spring terminal block
		Start	Input	100 mA maximum	
		3 in parallel	Relay outputs Normally open	24 Vdc / 230 Vac 6 A maximum per output	
TM3SAFL5R	2 functions, up to category 3	2 ⁽¹⁾	Safety inputs	24 Vdc	3.81 mm (0.15 in.) and 5.08 mm (0.20 in.), removable screw terminal block
		Start	Input	100 mA maximum	
		3 in parallel	Relay outputs Normally open	24 Vdc / 230 Vac 6 A maximum per output	
TM3SAFL5RG	2 functions, up to category 3	2 ⁽¹⁾	Safety inputs	24 Vdc	3.81 mm (0.15 in.) and 5.08 mm (0.20 in.), removable spring terminal block
		Start	Input	100 mA maximum	
		3 in parallel	Relay outputs Normally open	24 Vdc / 230 Vac 6 A maximum per output	
TM3SAK6R	3 functions, up to category 4	1 or 2 ⁽¹⁾	Safety inputs	24 Vdc	3.81 mm (0.15 in.) and 5.08 mm (0.20 in.), removable screw terminal block
		Start	Input	100 mA maximum	
		3 in parallel	Relay outputs Normally open	24 Vdc / 230 Vac 6 A maximum per output	
TM3SAK6RG	3 functions, up to category 4	1 or 2 ⁽¹⁾	Safety inputs	24 Vdc	3.81 mm (0.15 in.) and 5.08 mm (0.20 in.), removable spring terminal block
		Start	Input	100 mA maximum	
		3 in parallel	Relay outputs Normally open	24 Vdc / 230 Vac 6 A maximum per output	
⁽¹⁾ Depending on external wiring ⁽²⁾ Non-monitored start					

TM3 Transmitter and Receiver Modules

The following table shows the TM3 transmitter and receiver expansion modules:

Reference	Description	Terminal Type / Pitch
TM3XTRA1	Data transmitter module for remote I/O	1 front connector RJ-45 1 screw for functional ground connection
TM3XREC1	Data receiver module for remote I/O	1 front connector RJ-45 Power supply connector / 5.08 mm

TM3 Bus Couplers

Introduction

The TM3 bus coupler is a device designed to manage fieldbus communication when using TM3 expansion modules in a distributed architecture.

For more information, refer to the Modicon TM3 Bus Coupler Hardware Guide.

Modicon TM3 Bus Couplers

The following table shows the TM3 bus couplers, with ports and terminal types:

Reference	Port	Communication type	Terminal type
TM3BCEIP	2 isolated switched Ethernet ports	EtherNet/IP Modbus TCP	RJ45
	1 USB port	USB 2.0	USB mini-B
TM3BCSL	2 isolated RS-485 ports (daisy-chained)	Serial Line Modbus	RJ45
	1 USB port	USB 2.0	USB mini-B
TM3BCCO	2 isolated CANopen ports (daisy-chained)	CANopen	RJ45
	1 USB port	USB 2.0	USB mini-B

TM5 Fieldbus Interfaces

Introduction

The TM5 fieldbus interfaces are devices designed to manage EtherNet/IP and Sercos communication when using TM5 System and TM7 expansion modules with a controller in a distributed architecture.

For more information, refer to the Modicon TM5 System Interface – Hardware Guide.

TM5 Fieldbus Interfaces

The following table shows the TM5 fieldbus interfaces with ports and terminal type:

Reference	Port	Communication type	Terminal type
TM5NEIP1	2 Ethernet switched ports	EtherNet/IP	RJ45
TM5NS31	2 Ethernet switched ports	Sercos	RJ45

TM5 CANopen Fieldbus Interfaces

Introduction

The TM5 fieldbus module is a CANopen interface with built-in power distribution and is the first TM5 distributed I/O island.

For more information, refer to the Modicon TM5 CANopen Interface Hardware Guide.

Modicon TM5 CANopen Fieldbus Interfaces

The following table shows the TM5 CANopen fieldbus interfaces:

Reference	Communication type	Terminal type
TM5NCO1	CANopen	1 SUB-D 9, male

TM7 CANopen Fieldbus Interfaces

Introduction

The TM7 fieldbus modules are CANopen interfaces with 24 Vdc digital configurable input or output on 8 or 16 channels.

For more information, refer to the Modicon TM7 CANopen Interface I/O Blocks Hardware Guide.

Modicon TM7 CANopen Fieldbus Interfaces

The following table shows the TM7 CANopen fieldbus interfaces:

Reference	Number of channels	Voltage/Current	Communication type	Terminal type
TM7NCOM08B	8 inputs	24 Vdc / 4 mA	CANopen	M8 Connector
	8 outputs	24 Vdc / 500 mA		
TM7NCOM16A	16 inputs	24 Vdc / 4 mA	CANopen	M8 Connector
	16 outputs	24 Vdc / 500 mA		
TM7NCOM16B	16 inputs	24 Vdc / 4 mA	CANopen	M12 Connector
	16 outputs	24 Vdc / 500 mA		

TMS Expansion Modules

Introduction

TMS expansion modules attach to the left side of the controller to provide additional communication possibilities. The modules are dedicated to Ethernet and CANopen high-speed communication.

For more information, refer to the TMS Expansion Modules Hardware Guide.

TMS Expansion Modules

The following table describes the TMS expansion module features:

Module reference	Type	Terminal type	Compatibility
TMSES4	Ethernet communication	RJ45	TM262L10MESE8T TM262L20MESE8T TM262M15MESS8T TM262M25MESS8T TM262M35MESS8T
TMSCO1	CANopen master module	SUB-D 9 pin male	TM262L• TM262M•

Accessories

Overview

This section describes the accessories and cables.

Accessories

Reference	Description	Use	Quantity
TMASD1	SD Card, page 36	Use to update the controller firmware, initialize a controller with a new application or clone a controller, apply post configuration file to the controller, store recipe files, and receive data logging files.	1
TMA262SET8G	Removable 11-pt spring terminal block (pitch 3.81 mm): <ul style="list-style-type: none"> 3 terminals for 24 Vdc I/O 4 terminals for inputs 4 terminals for outputs 	Connects 24 Vdc power supply and embedded I/Os.	
	Removable 5-pt spring terminal block (pitch 5.08 mm): <ul style="list-style-type: none"> 3 terminals for 24 Vdc I/O 2 terminals for relay output 	Connects 24 Vdc power supply and relay output.	
TMA262SET8S	Removable 11-pt screw terminal block (pitch 3.81 mm): <ul style="list-style-type: none"> 3 terminals for 24 Vdc I/O 4 terminals for inputs 4 terminals for outputs 	Connects 24 Vdc power supply and embedded I/Os.	
	Removable 5-pt screw terminal block (pitch 5.08 mm): <ul style="list-style-type: none"> 3 terminals for 24 Vdc I/O 2 terminals for relay output 	Connects 24 Vdc power supply and relay output.	
NSYTRAAB35	End brackets	Helps secure the controller or receiver module and their expansion modules on a top hat section rail (DIN rail).	
TMAM3	2 attachment parts	Mounts the controller and TMS modules directly to a flat, vertical panel.	
TM200RSRCEMC	Shielding take-up clip	Mounts and connects the ground to the cable shielding.	25-pack

For top hat section rails (DIN rails), refer to Top Hat Section Rail (DIN rail), page 49.

Cables

Reference	Description	Details	Length
TCSXCNAMUM3P	Terminal port/USB port cordset	From the USB mini-B port on the M262 Logic/Motion Controller to USB port on the PC terminal.	3 m (10 ft)
BMXXCAUSBH018		From the USB mini-B port on the M262 Logic/Motion Controller to USB port on the PC terminal. NOTE: Grounded and shielded, this USB cable is suitable for long-duration connections.	1.8 m (5.9 ft)
TCSMCN3M4F3C2	RS-232 serial link cordset	For DTE terminal (printer). 1 RJ45 connector and 1 SUB-D 9 connector.	3 m (9.84 ft)
TCSMCN3M4M3S2		For DCE terminal (modem, converter) 1 RJ45 connector and 1 SUB-D 9 connector	
490NTW000**	Ethernet shielded cable for DTE connections	Standard cable, equipped with RJ45 connectors at each end for DTE. CE compliant.	2, 5, 12, 40, or 80 m (6.56, 16.4, 39.37, 131.23 or 262.47 ft)
490NTW000**U		Standard cable, equipped with RJ45 connectors at each end for DTE. UL compliant.	
TCSECE3M3M**S4		Cable for harsh environment, equipped with RJ45 connectors at each end. CE compliant.	1, 2, 3, 5, or 10 m (3.28, 6.56, 9.84, 16.4, 32.81 ft)
TCSECU3M3M**S4		Cable for harsh environment, equipped with RJ45 connectors at each end. UL compliant.	
VW3A8306R**	Cable for Modbus serial link connections	Cable equipped with RJ45 connectors at each end for Modbus serial link.	0.3, 1, or 3 m (0.98, 3.28, or 9.84 ft)
VW3E5001R***	Sercos cable	Cable with T J45 connectors at each end.	0.5, 1, 1.5, 2, 3, 5, 10, 15, 20, 25, 30, 40, or 50 m (1.64, 3.28, 4.92, 6.56, 9.84, 16.4, 32.8, 49.2, 65.6, 82, 98.4, 131.2, or 164 ft)

M262 Features

Real Time Clock (RTC)

Overview

The M262 Logic/Motion Controller includes a real-time clock (RTC) to provide system date and time information and to support related functions requiring a real-time clock.

The RTC also provides the system date and time to any TMS expansion modules (see Modicon TMS Expansion Module, Hardware Guide) installed on the left side of the controller.

Provided the controller has been powered on for at least 2 hours, the system date and time are maintained for 1000 hours at 25 °C (77 °F) even when the controller is powered off.

This table shows how RTC drift is managed:

RTC Characteristics	Description
RTC drift	Less than 15 seconds per month with no user calibration at 25 °C (77 °F)

To set and calibrate the RTC in EcoStruxure Machine Expert, use either:

- The **Services** tab (see M262 Logic/Motion Controller, Programming Guide).
- The `SysTimeRtcSet` function block (see Getting & Setting Real Time Clock, SysTimeRtc and SysTimeCore Library Guide).

Input Management

Overview

The M262 Logic/Motion Controller features 4 fast digital inputs.

The following functions are configurable:

- Filters (depends on the function associated with the input).
- All inputs can be used for the Run/Stop function.
- The inputs can be either latched or used for events (rising edge, falling edge, or both) and thus be linked to an external task.

NOTE: All inputs can be used as regular inputs.

Input Management Functions Availability

Embedded digital inputs can be configured as functions (Run/Stop, events).

Inputs not configured as functions are used as regular inputs.

Filter Principle

The filter is designed to reduce the bouncing effect at the inputs. Setting the filter value allows the controller to ignore some sudden changes of input levels caused by electrical noise. The filter is only available on the fast inputs.

The following timing diagram illustrates the anti-bounce filter effects:

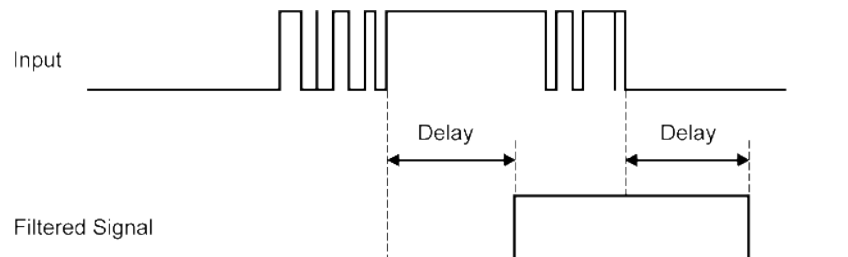

Latching

Latching is a function that can be assigned to the M262 Logic/Motion Controller fast inputs. This function is used to memorize (or latch) any pulse with a duration that is less than the M262 Logic/Motion Controller scan time.

When a pulse is shorter than one scan, the controller latches the pulse, which is then updated in the next scan. This latching mechanism only recognizes rising edges. Falling edges cannot be latched. Assigning inputs to be latched is done in the software **I/O Configuration** tab.

The following timing diagram illustrates the latching effects:

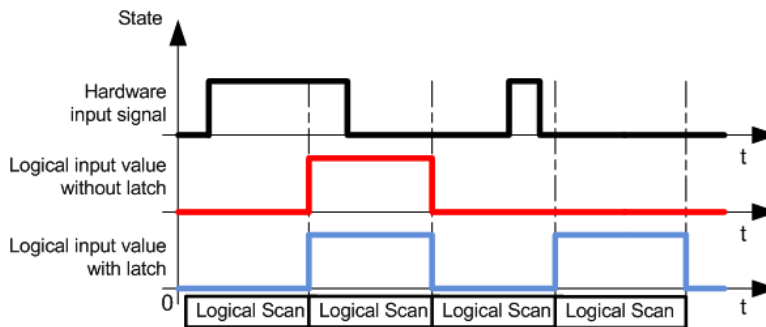

Event

An input configured for Event can be associated with an External Task (see Modicon M262 Logic/Motion Controller, Programming Guide).

Run/Stop

The Run/Stop function is used to start or stop an application program using an input. In addition to the embedded Run/Stop switch, it is allowed to configure one (and only one) input as an additional Run/Stop command.

For more information, refer to *Run/Stop*, page 35.

⚠ WARNING

UNINTENDED MACHINE OR PROCESS START-UP

- Verify the state of security of your machine or process environment before applying power to the Run/Stop input.
- Use the Run/Stop input to help prevent the unintentional start-up from a remote location.

Failure to follow these instructions can result in death, serious injury, or equipment damage.

⚠ WARNING

UNINTENDED EQUIPMENT OPERATION

Use the sensor and actuator power supply only for supplying power to sensors or actuators connected to the module.

Failure to follow these instructions can result in death, serious injury, or equipment damage.

Output Management

Introduction

The M262 Logic/Motion Controller features fast digital outputs.

Alarm output functions can be configured on the outputs.

NOTE: All outputs can be used as regular outputs.

Fallback Modes (Behavior for Outputs in Stop)

When the controller enters the STOPPED or one of the exception states for any reason, the local (embedded and expansion) outputs are set to **Default Value** defined in the application.

Short-circuit or Over-current on Outputs

In the case of a short-circuit or current overload, all outputs enter into thermal or over-current protection mode (all outputs are set to 0), and are then periodically rearmed (every 10 seconds) to test the connection state. However, you must be aware of the effect of this rearming on the machine or process being controlled.

⚠ WARNING
UNINTENDED MACHINE START-UP
Inhibit the automatic rearming of outputs if this feature is an undesirable behavior for your machine or process.
Failure to follow these instructions can result in death, serious injury, or equipment damage.

NOTE: The automatic rearming feature can be inhibited. Refer to the Programming Guide of your controller for more information.

Run/Stop

Overview

The M262 Logic/Motion Controller can be operated externally by the following:

- A hardware Run/Stop switch.
- A software command.
- A Run/Stop operation triggered by an embedded digital input. The digital input is defined in the software configuration. For more information, refer to the M262 Logic/Motion Controller Programming Guide.
- The system variable PLC_W in a Relocation Table (see Modicon M262 Logic/Motion Controller, Programming Guide).
- The Web server (see Modicon M262 Logic/Motion Controller, Programming Guide).

The M262 Logic/Motion Controller has a hardware Run/Stop switch, which puts the controller in the RUNNING or STOPPED state.

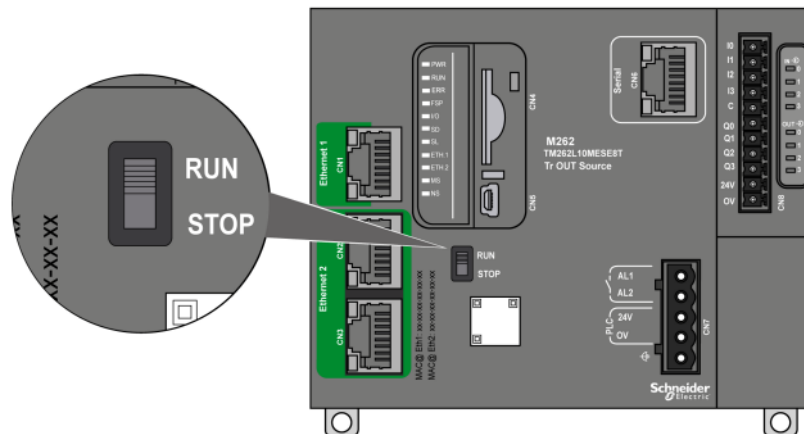

The interaction of the 2 external operators on the controller state behavior is summarized in the table below:

		Embedded hardware Run/Stop switch		
		Switch on Stop	Stop to Run transition	Switch on Run
Software configurable Run/Stop digital input	None	STOPPED	Commands a transition to RUNNING state ⁽¹⁾ .	Allows external Run/Stop commands.
	State 0	Ignores external Run/Stop commands.	STOPPED	STOPPED
	Rising edge		Ignores external Run/Stop commands.	Ignores external Run/Stop commands.
	State 1		Commands a transition to RUNNING state ⁽¹⁾ .	Commands a transition to RUNNING state.
Commands a transition to RUNNING state ⁽¹⁾ .			Allows external Run/Stop commands.	

⁽¹⁾ For more information, refer to the M262 Logic/Motion Controller Programming Guide.

⚠ WARNING

UNINTENDED MACHINE OR PROCESS START-UP

- Verify the state of security of your machine or process environment before applying power to the Run/Stop input or engaging the Run/Stop switch.
- Use the Run/Stop input to help prevent the unintentional start-up from a remote location, or from accidentally engaging the Run/Stop switch.

Failure to follow these instructions can result in death, serious injury, or equipment damage.

SD Card

Overview

The main uses of the SD card are:

- Downloading a new application to the controller without using the software.
- Updating the controller firmware.
- Cloning the controller application or firmware.
- Applying post configuration changes to the controller (for example, changing IP addresses or serial line configuration).
- Applying recipe files.
- Retrieving data logging files.

The SD card file system is FAT32. SD card files can therefore be used directly on your computer.

When handling the SD card, follow the instructions below to help prevent internal data on the SD card from being corrupted or lost or an SD card malfunction from occurring:

NOTICE

LOSS OF APPLICATION DATA

- Do not store the SD card where there is static electricity or probable electromagnetic fields.
- Do not store the SD card in direct sunlight, near a heater, or other locations where high temperatures can occur.
- Do not bend the SD card.
- Do not drop or strike the SD card against another object.
- Keep the SD card dry.
- Do not touch the SD card connectors.
- Do not disassemble or modify the SD card.
- Use only SD cards formatted using FAT or FAT32.

Failure to follow these instructions can result in equipment damage.

The M262 Logic/Motion Controller does not recognize NTFS formatted SD cards. Format the SD card on your computer using FAT or FAT32.

When using the M262 Logic/Motion Controller and an SD card, observe the following to avoid losing valuable data:

- Accidental data loss can occur at any time. Once data is lost it cannot be recovered.
- If you forcibly extract the SD card, data on the SD card may become corrupted.
- Removing an SD card that is being accessed (**SD** LED flashing yellow) could damage the SD card, or corrupt its data.
- If the SD card is not positioned correctly when inserted into the controller, the data on the card and the controller could become damaged.

NOTICE

LOSS OF APPLICATION DATA

- Backup SD card data regularly.
- Do not remove power or reset the controller, and do not insert or remove the SD card while it is being accessed.

Failure to follow these instructions can result in equipment damage.

The following figure shows the SD card slot:

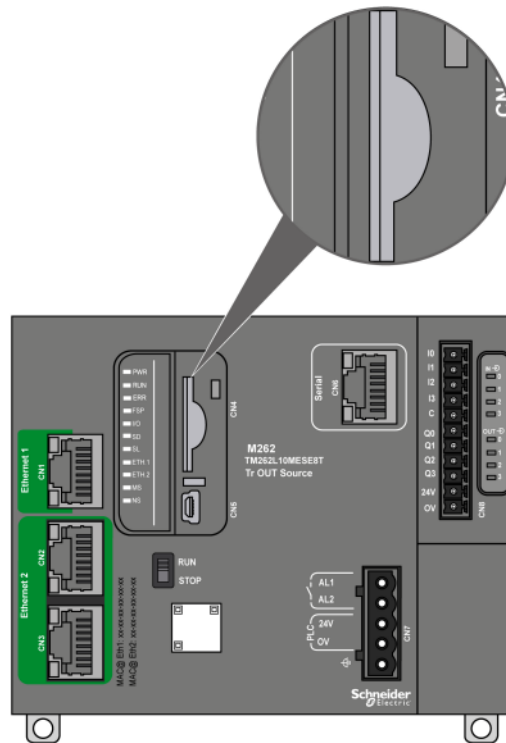

It is possible to set the Write-Control Tab to prevent write operations to the SD card. Push the tab up, as shown in the example on the right-hand side, to release the lock and enable writing to the SD card. Before using an SD card, read the manufacturer's instructions.

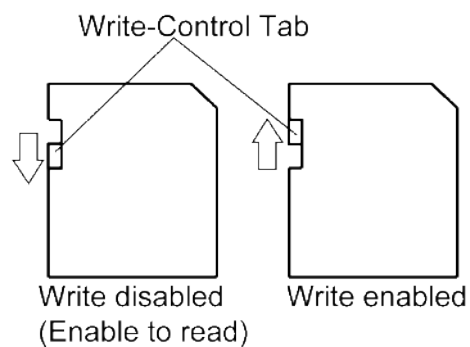

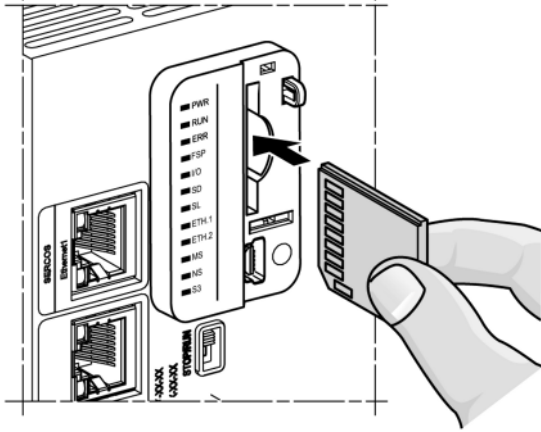
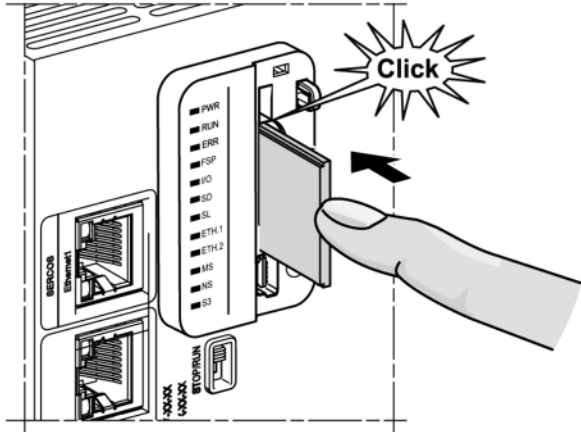
Step	Action
1	Insert the SD card into the SD card slot: 
2	Push until you hear it "click": 

SD Card Slot Characteristics

Topic	Characteristics	Description
Supported type	Standard Capacity	SDSC
	High Capacity	SDHC
Global memory	Size	32 GB maximum (SDHC only)

TMASD1 Characteristics

Characteristics	Description
Card removal durability	Minimum 1000 times
File retention time	10 years at 25 °C (77 °F)
Flash type	SLC NAND
Memory size	256 MB
Ambient operation temperature	-10...85 °C (14...185 °F)
Storage temperature	-25...85 °C (-13...185 °F)
Relative humidity	95% maximum non-condensing
Write/Erase cycles	3,000,000 (approximately)

Status LED

The following figure shows the **SD** status LED:

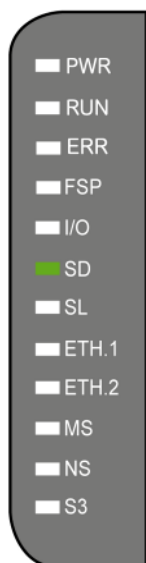

The following table describes the **SD** status LED:

Label	Description	LED	
		State	Description
SD	SD card	Green On	Firmware update completed.
		Green Flashing	Firmware update or script execution in progress.
		Yellow On	Firmware update or script execution is unsuccessful.
		Yellow Flashing	SD card is being accessed (script execution in progress).
		Off	No SD card activity.

Alarm Relay

Introduction

The M262 Logic/Motion Controller has integrated relay connections that can be wired to an external alarm:

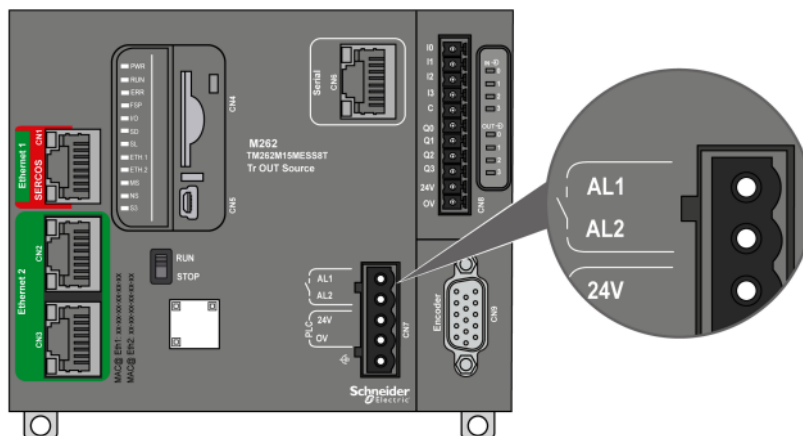

For wiring details, refer to Alarm Relay Wiring, page 66.

Characteristics

This table shows the characteristics of the alarm relay:

Characteristic	Value
Wiring type	2 terminals on removable spring terminal block
Output type	Relay
Contact type	Normally Open (NO)
Nominal input voltage	24 Vdc
Maximum input voltage	28.8 Vdc
Input voltage type	PELV
Contact resistance	300 mΩ maximum
Minimum switching load	5 V at 100 mA
Maximum current	700 mA
Overload protection	Yes, resettable fuse, maximum 3.2 A
Reverse polarity protection	Not necessary

Operation

When the controller is energized, the alarm relay is activated and its contact is closed.

The relay contact is opened by one of the following conditions:

- Appearance of an internal hardware error.
- Interruption of the controller power supply.

Perform a power cycle of the controller to recover from a hardware watchdog event and reset the relay output contact to the closed state.

When the controller is de-energized, the alarm relay is deactivated and its contact is opened.

M262 Installation

Overview

This chapter provides installation safety guidelines, device dimensions, mounting instructions, and environmental specifications.

M262 Logic/Motion Controller General Rules for Implementing

Environmental Characteristics

Enclosure Requirements

M262 Logic/Motion Controller system components are designed as Zone B, Class A industrial equipment according to IEC/CISPR Publication 11. If they are used in environments other than those described in the standard, or in environments that do not meet the specifications in this manual, the ability to meet electromagnetic compatibility requirements in the presence of conducted and/or radiated interference may be reduced.

All M262 Logic/Motion Controller system components meet European Community (CE) requirements for open equipment as defined by IEC/EN 61131-2. You must install them in an enclosure designed for the specific environmental conditions and to minimize the possibility of unintended contact with hazardous voltages. Use metal enclosures to improve the electromagnetic immunity of your M262 Logic/Motion Controller system. Use enclosures with a keyed locking mechanism to minimize unauthorized access.

Environmental Characteristics

All the M262 Logic/Motion Controller module components are electrically isolated between the internal electronic circuit and the input/output channels within the limits set forth and described by these environmental characteristics. For more information on electrical isolation, see the technical specifications of your particular controller found later in the current document. This equipment meets CE requirements as indicated in the table below. This equipment is intended for use in a Pollution Degree 2 industrial environment.

▲ WARNING

UNINTENDED EQUIPMENT OPERATION

Do not exceed any of the rated values specified in the environmental and electrical characteristics tables.

Failure to follow these instructions can result in death, serious injury, or equipment damage.

The following table shows the general environmental characteristics:

Characteristic	Minimum Specification	Tested Range	
Standard compliance	IEC/EN 61131-2 UL/CSA 61010-1, -2-201	–	
Ambient operating temperature	–	Horizontal installation	-20...60 °C (-4...140 °F)
	–	Vertical installation	-20...50 °C (-4...122 °F)
	–	Flat installation	-20...45 °C (-4...113 °F)
Transport/storage temperature	–	-40...85 °C (-40...185 °F)	
Relative humidity	–	Transport and storage	5...95 % (non-condensing)
	–	Operation	5...95 % (non-condensing)
Degree of pollution	IEC/EN 60664-1	2	
Degree of protection	IEC/EN 61131-2	IP20 with protective covers in place	
Corrosion immunity	–	Atmosphere free from corrosive gases	
Operating altitude	–	0...2000 m (0...6560 ft)	
Storage altitude	–	0...3000 m (0...9843 ft)	
Vibration resistance	IEC/EN 61131-2	Panel mounting or mounted on a top hat section rail (DIN rail)	3.5 mm (0.13 in) fixed amplitude from 2...8.4 Hz 9.8 m/s ² (32.15 ft/s ²) (1 g _n) fixed acceleration from 8.4...200 Hz
Mechanical shock resistance	–	147 m/s ² (482.28 ft/s ²) (15 g _n) for a duration of 11 ms	
<p>NOTE: The tested ranges may indicate values beyond that of the IEC Standard. However, our internal standards define what is necessary for industrial environments. In all cases, we uphold the minimum specification if indicated.</p>			

Electromagnetic Susceptibility

The M262 Logic/Motion Controller system meets electromagnetic susceptibility specifications as indicated in the following table:

Characteristic	Minimum Specification	Tested Range		
Electrostatic discharge	IEC/EN 61000-4-2 IEC/EN 61131-2	8 kV (air discharge) 4 kV (contact discharge)		
Radiated electromagnetic field	IEC/EN 61000-4-3 IEC/EN 61131-2	10 V/m (80...1000 MHz) 3 V/m (1.4...2 GHz) 1 V/m (2...3 GHz)		
Fast transients burst	IEC/EN 61000-4-4 IEC/EN 61131-2	24 Vdc main power lines	2 kV (CM ¹ and DM ²)	
		24 Vdc I/Os	2 kV (clamp)	
		Relay output	1 kV (clamp)	
		Digital I/Os	1 kV (clamp)	
		Communication line	1 kV (clamp)	
Surge immunity	IEC/EN 61000-4-5 IEC/EN 61131-2	–	CM ¹	DM ²
		DC Power lines	0.5 kV	0.5 kV
		Relay Outputs	–	–
		24 Vdc I/Os	–	–
		Shielded cable (between shield and ground)	1 kV	–
Induced electromagnetic field	IEC/EN 61000-4-6 IEC/EN 61131-2	10 Vrms (0.15...80 MHz)		
Conducted emission	IEC 61000-6-4 IEC/EN 61131-2	<ul style="list-style-type: none"> • 10...150 kHz: 120...69 dBμV/m QP • 150...1500 kHz: 79...63 dBμV/m QP • 1.5...30 MHz: 63 dBμV/m QP 		
Radiated emission	IEC 61000-6-4	30...230 MHz: 40 dB μ V/m QP		
	IEC/EN 61131-2	230...1000 MHz: 47 dB μ V/m QP		
1 Common Mode 2 Differential Mode NOTE: The tested ranges may indicate values beyond that of the IEC Standard. However, our internal standards define what is necessary for industrial environments. In all cases, we uphold the minimum specification if indicated.				

Certifications and Standards

Introduction

For information on certifications and conformance to standards, go to www.se.com.

For product compliance and environmental information (RoHS, REACH, PEP, EOL, etc.), go to www.se.com/green-premium.

M262 Logic/Motion Controller Installation

Installation and Maintenance Requirements

Before Starting

Read and understand this chapter before beginning the installation of your system.

The use and application of the information contained herein require expertise in the design and programming of automated control systems. Only you, the user, machine builder or integrator, can be aware of all the conditions and factors present during installation and setup, operation, and maintenance of the machine or process, and can therefore determine the automation and associated equipment and the related safeties and interlocks which can be effectively and properly used. When selecting automation and control equipment, and any other related equipment or software, for a particular application, you must also consider any applicable local, regional or national standards and/or regulations.

Pay particular attention in conforming to any safety information, different electrical requirements, and normative standards that would apply to your machine or process in the use of this equipment.

Disconnecting Power

All options and modules should be assembled and installed before installing the control system on a mounting rail, onto a mounting plate or in a panel. Remove the control system from its mounting rail, mounting plate or panel before disassembling the equipment.

DANGER

HAZARD OF ELECTRIC SHOCK, EXPLOSION OR ARC FLASH

- Disconnect all power from all equipment including connected devices prior to removing any covers or doors, or installing or removing any accessories, hardware, cables, or wires except under the specific conditions specified in the appropriate hardware guide for this equipment.
- Always use a properly rated voltage sensing device to confirm the power is off where and when indicated.
- Replace and secure all covers, accessories, hardware, cables, and wires and confirm that a proper ground connection exists before applying power to the equipment.
- Use only the specified voltage when operating this equipment and any associated products.

Failure to follow these instructions will result in death or serious injury.

Programming Considerations

WARNING

UNINTENDED EQUIPMENT OPERATION

- Only use software approved by Schneider Electric for use with this equipment.
- Update your application program every time you change the physical hardware configuration.

Failure to follow these instructions can result in death, serious injury, or equipment damage.

Operating Environment

In addition to the Environmental Characteristics, page 42, refer to Product Related Information, page 7 in the beginning of the present document for important information regarding installation in hazardous locations for this specific equipment.

⚠ WARNING

UNINTENDED EQUIPMENT OPERATION

Install and operate this equipment according to the conditions described in the Environmental Characteristics.

Failure to follow these instructions can result in death, serious injury, or equipment damage.

Installation Considerations

⚠ WARNING

UNINTENDED EQUIPMENT OPERATION

- Use appropriate safety interlocks where personnel and/or equipment hazards exist.
- Install and operate this equipment in an enclosure appropriately rated for its intended environment and secured by a keyed or tooled locking mechanism.
- Use the sensor and actuator power supplies only for supplying power to the sensors or actuators connected to the module.
- Power line and output circuits must be wired and fused in compliance with local and national regulatory requirements for the rated current and voltage of the particular equipment.
- Do not use this equipment in safety-critical machine functions unless the equipment is otherwise designated as functional safety equipment and conforming to applicable regulations and standards.
- Do not disassemble, repair, or modify this equipment.
- Do not connect any wiring to reserved, unused connections, or to connections designated as No Connection (N.C.).

Failure to follow these instructions can result in death, serious injury, or equipment damage.

NOTE: JDYX2 or JDYX8 fuse types are cULus-recognized.

M262 Logic/Motion Controller Mounting Positions and Clearances

Introduction

This section describes the correct mounting positions for the M262 Logic/Motion Controller.

NOTE: Keep adequate spacing for proper ventilation and to maintain the operating temperature specified in the Environmental Characteristics, page 42.

Correct Mounting Position

To obtain optimal operating characteristics, the M262 Logic/Motion Controller should be mounted as shown in the figures below:

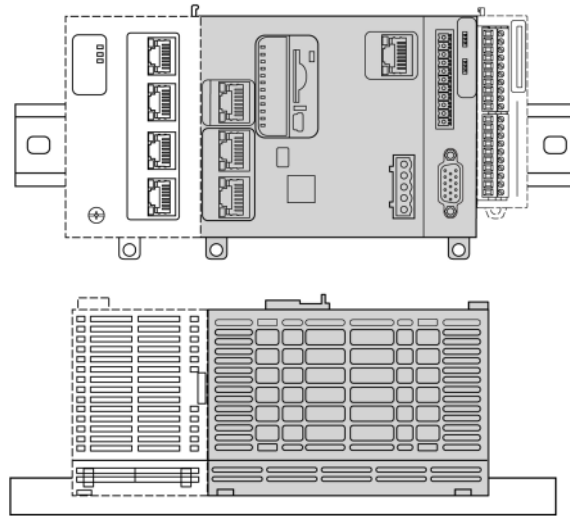

Acceptable Mounting Position

The M262 Logic/Motion Controller can also be mounted vertically on a vertical plane as shown below:

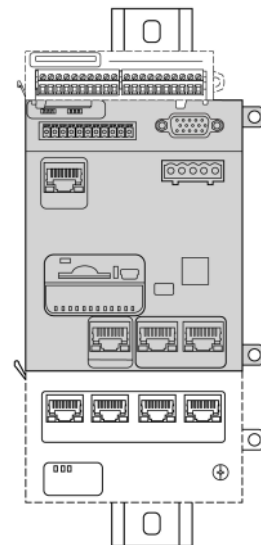

NOTE: TM3 expansion modules must be mounted above the controller.

Incorrect Mounting Positions

The M262 Logic/Motion Controller should only be positioned as shown in the Correct Mounting Position, page 47 figures. The figures below show incorrect mounting positions:

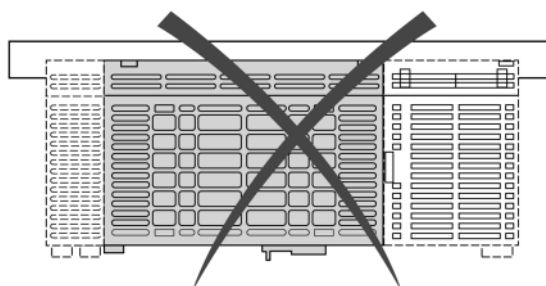
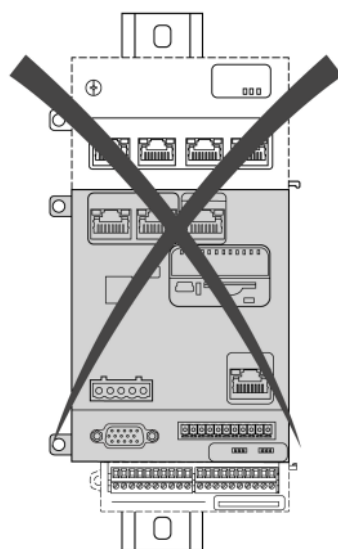
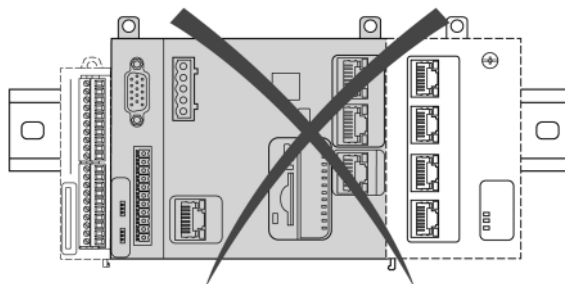

Minimum Clearances

⚠ WARNING

UNINTENDED EQUIPMENT OPERATION

- Place devices dissipating the most heat at the top of the cabinet and ensure adequate ventilation.
- Avoid placing this equipment next to or above devices that might cause overheating.
- Install the equipment in a location providing the minimum clearances from all adjacent structures and equipment as directed in this document.
- Install all equipment in accordance with the specifications in the related documentation.

Failure to follow these instructions can result in death, serious injury, or equipment damage.

The M262 Logic/Motion Controller has been designed as an IP20 product and must be installed in an enclosure. Clearances must be respected when installing the product.

There are three types of clearances to consider:

- The M262 Logic/Motion Controller and all sides of the cabinet (including the panel door).
- The M262 Logic/Motion Controller terminal blocks and the wiring ducts to help reduce potential electromagnetic interference between the controller and the duct wiring.
- The M262 Logic/Motion Controller and other heat generating devices installed in the same cabinet.

The following figures show the minimum clearances that apply to all M262 Logic/Motion Controller references:

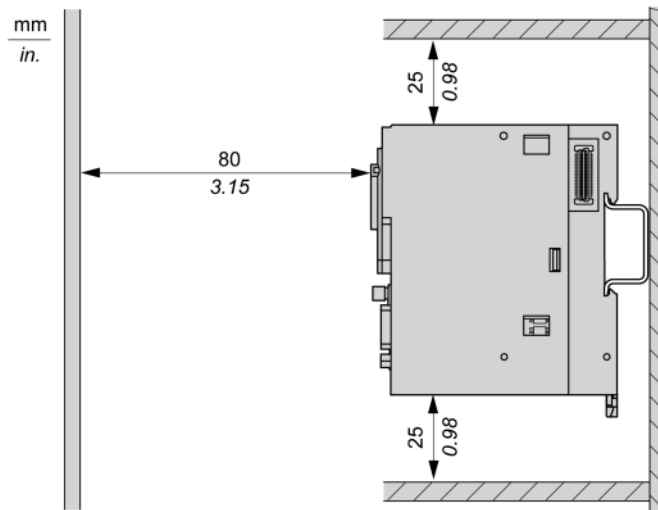
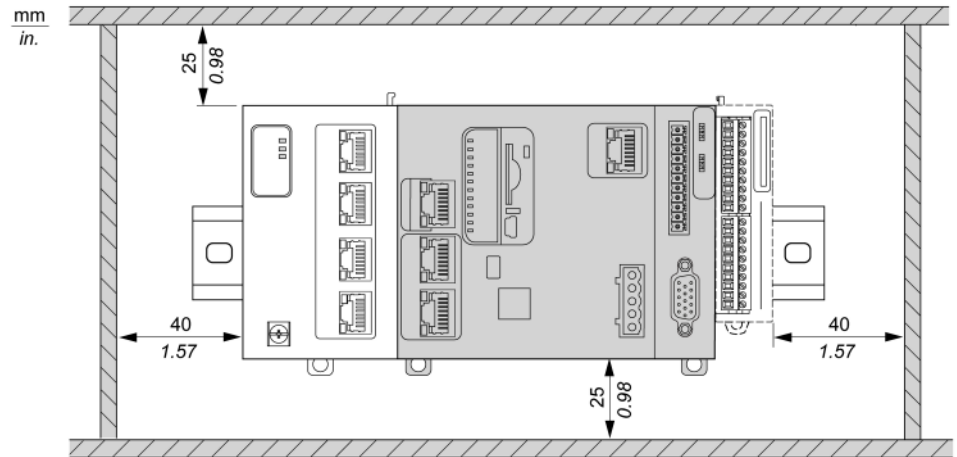

Top Hat Section Rail (DIN rail)

Dimensions of Top Hat Section Rail DIN Rail

You can mount the controller or receiver and their expansions on a 35 mm (1.38 in.) top hat section rail (DIN rail). The DIN rail can be attached to a smooth mounting surface or suspended from an EIA rack or mounted in a NEMA cabinet.

Symmetric Top Hat Section Rails (DIN Rail)

The following illustration and table indicate the references of the top hat section rails (DIN rail) for the wall-mounting range:

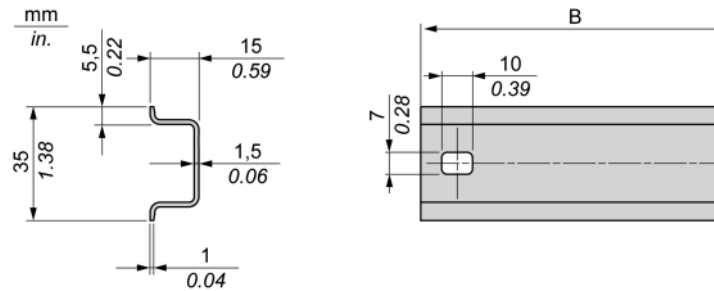

Reference	Type	Perforated	Rail Length (B)
NSYSDR50A	A	At each end	450 mm (17.71 in.)
NSYSDR60A	A	At each end	550 mm (21.65 in.)
NSYSDR80A	A	At each end	750 mm (29.52 in.)
NSYSDR100A	A	At each end	950 mm (37.40 in.)

The following illustration and table indicate the references of the symmetric top hat section rails (DIN rail) of 2000 mm (78.74 in.):

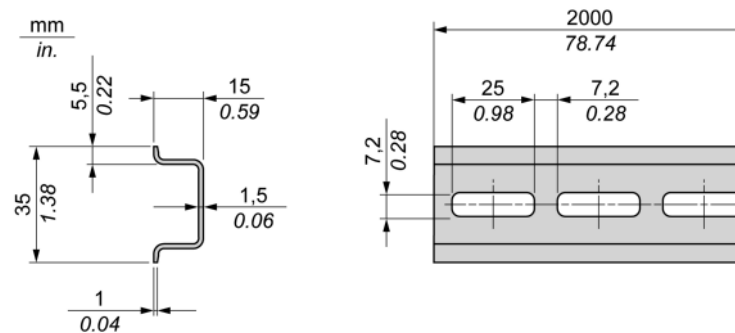

Reference	Type	Perforated	Rail Length
NSYSDR200	A	No	2000 mm (78.74 in.)
NSYSDR200D	A	Yes	

Double-Profile Top Hat Section Rails (DIN rail)

The following illustration and table indicate the references of the double-profile top hat section rails (DIN rail) of 2000 mm (78.74 in.):

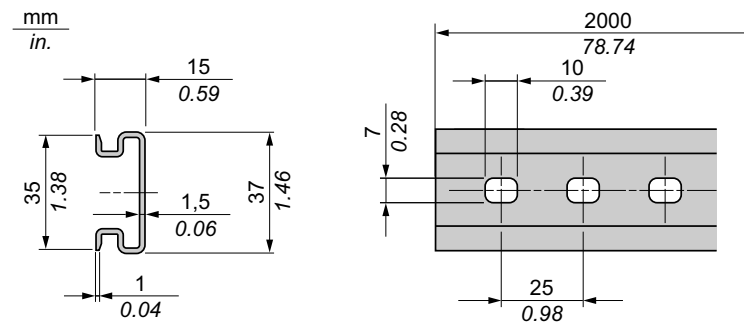

Reference	Type	Perforated	Rail Length
NSYDPR200	–	No	2000 mm (78.74 in.)
NSYDPR200D	–	Yes	

Installing and Removing the Controller with Expansions



Overview

This section describes how to install and remove the controller with its expansion modules from a top hat section rail (DIN rail).

To assemble expansion modules to the controller, or to other modules, refer to the respective expansion modules hardware guide(s).

Installing a Controller with its Expansions on a DIN Rail

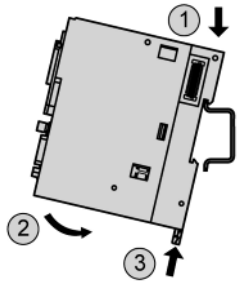
The following procedure describes how to install a controller with its expansion modules on a top hat section rail (DIN rail):

Step	Action
1	Fasten the top hat section rail (DIN rail) to a panel surface using screws.
2	Position the top groove of the controller and its expansion modules on the top edge of the DIN rail and press the assembly against the top hat section rail (DIN rail) until you hear the top section rail (DIN rail) click into place: <div style="text-align: center;">  </div>
3	Place 2 terminal block end clamps on both sides of the controller and expansion module assembly. <div style="text-align: center;">  </div> <p>NOTE: Type NSYTRAAB35 or equivalent terminal block end clamps help minimize sideways movement and improve the shock and vibration characteristics of the controller and expansion module assembly.</p>

Removing a Controller with its Expansions from a Top Hat Section Rail (DIN Rail)

The following procedure describes how to remove a controller with its expansion modules from a top hat section rail (DIN rail):

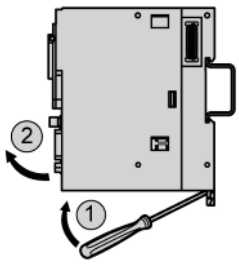
Step	Action
1	Remove all power from your controller and expansion modules.
2	Insert a flat screwdriver into the slot of the top hat section rail (DIN rail) clip: <div style="text-align: center;">  </div>
3	Pull down the top hat section rail (DIN rail) clip.
4	Pull the controller and its expansion modules from the top hat section rail (DIN rail) from the bottom.

Mounting a M262 Logic/Motion Controller on a Panel Surface

Installing the Panel Mounting Kit

Insert TMAM3, page 31 mounting strips into the slots at the top of the M262 Logic/Motion Controller:

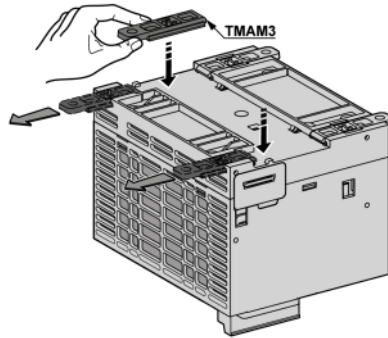

Mounting Holes

The following figure shows the mounting holes for the M262 Logic/Motion Controller:

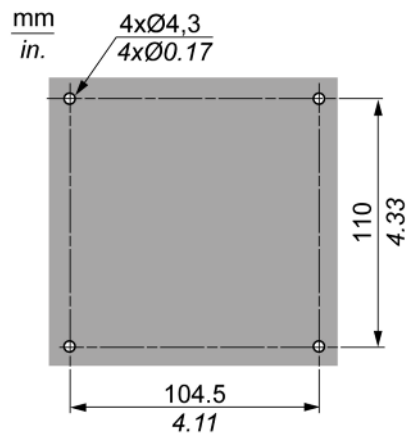

Verify that the installation panel or cabinet surface is flat (planarity tolerance: 0.5 mm (0.019 in)), in good condition, and has no jagged edges.

Mounting the M262 Logic/Motion Controller on a Metallic Panel

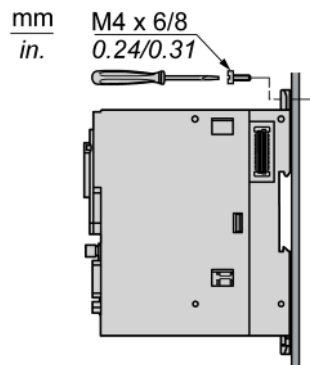

If mounting the controller on a horizontal metallic panel, use flat head screws.

M262 Electrical Requirements

Wiring Best Practices

Overview

This section describes the wiring guidelines and associated best practices to be respected when using the M262 Logic/Motion Controller system.

DANGER

HAZARD OF ELECTRIC SHOCK, EXPLOSION OR ARC FLASH

- Disconnect all power from all equipment including connected devices prior to removing any covers or doors, or installing or removing any accessories, hardware, cables, or wires except under the specific conditions specified in the appropriate hardware guide for this equipment.
- Always use a properly rated voltage sensing device to confirm the power is off where and when indicated.
- Replace and secure all covers, accessories, hardware, cables, and wires and confirm that a proper ground connection exists before applying power to the equipment.
- Use only the specified voltage when operating this equipment and any associated products.

Failure to follow these instructions will result in death or serious injury.

WARNING

LOSS OF CONTROL

- Perform a Failure Mode and Effects Analysis (FMEA), or equivalent risk analysis, of your application, and apply preventive and detective controls before implementation.
- Provide a fallback state for undesired control events or sequences.
- Provide separate or redundant control paths wherever required.
- Supply appropriate parameters, particularly for limits.
- Review the implications of transmission delays and take actions to mitigate them.
- Review the implications of communication link interruptions and take actions to mitigate them.
- Provide independent paths for control functions (for example, emergency stop, over-limit conditions, and error conditions) according to your risk assessment, and applicable codes and regulations.
- Apply local accident prevention and safety regulations and guidelines.¹
- Test each implementation of a system for proper operation before placing it into service.

Failure to follow these instructions can result in death, serious injury, or equipment damage.

¹ For additional information, refer to NEMA ICS 1.1 (latest edition), *Safety Guidelines for the Application, Installation, and Maintenance of Solid State Control* and to NEMA ICS 7.1 (latest edition), *Safety Standards for Construction and Guide for Selection, Installation and Operation of Adjustable-Speed Drive Systems* or their equivalent governing your particular location.

Wiring Guidelines

These rules must be applied when wiring a M262 Logic/Motion Controller system:

- Communication wiring must be kept separate from the power wiring. Route these 2 types of wiring in separate cable ducting.
- Verify that the operating conditions and environment are within the specification values.
- Use proper wire sizes to meet voltage and current requirements.
- Use minimum 75 °C (167 °F) copper conductors (required).
- Use twisted pair, shielded cables for encoder, networks, and serial communication connections.

Use shielded, properly grounded cables for all communication connections. If you do not use shielded cable for these connections, electromagnetic interference can cause signal degradation. Degraded signals can cause the controller or attached modules and equipment to perform in an unintended manner.

⚠ WARNING

UNINTENDED EQUIPMENT OPERATION

- Use shielded cables for all communication signals.
- Ground cable shields for all communication signals at a single point¹.
- Route communication separately from power cables.

Failure to follow these instructions can result in death, serious injury, or equipment damage.

¹Multipoint grounding is permissible if connections are made to an equipotential ground plane dimensioned to help avoid cable shield damage in the event of power system short-circuit currents.

For more details, refer to [Grounding Shielded Cables](#), page 62.

NOTE: Surface temperatures may exceed 60 °C (140 °F).

To conform to IEC 61010 standards, route primary wiring (wires connected to power mains) separately and apart from secondary wiring (extra low voltage wiring coming from intervening power sources). If that is not possible, double insulation is required such as conduit or cable gains.

Rules for Spring Terminal Blocks

The following tables show the cable types and wire sizes for the CN7 **5.08 pitch** removable spring terminal block of the embedded 24 Vdc power supply input / alarm relay terminal connector:









$\frac{\text{mm}}{\text{in.}}$ 					
mm ²	0,2...2,5	0,2...2,5	0,25...2,5	0,25...2,5	2 x 0,5...1
AWG	24...14	24...14	22...14	22...14	2 x 20...18

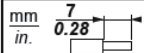

The following tables show the cable types and wire sizes for the CN8 **3.81 pitch** removable spring terminal block of the embedded I/Os connector:

$\frac{\text{mm}}{\text{in.}}$ 				
mm ²	0,2...1,5	0,2...1,5	0,25...1,0	0,25...0,5
AWG	24...16	24...16	23...18	23...21









Rules for Screw Terminal Blocks

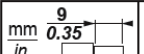

The following tables show the cable types and wire sizes for the CN7 **5.08 pitch** removable screw terminal block of the embedded 24 Vdc power supply input / alarm relay terminal connector:

								
mm ²	0.2...2.5	0.2...2.5	0.25...2.5	0.25...2.5	2 x 0.2...1	2 x 0.2...1.5	2 x 0.25...1	2 x 0.5...1.5
AWG	24...14	24...14	22...14	22...14	2 x 24...18	2 x 24...16	2 x 22...18	2 x 20...16

		N•m	0.49
Ø 3,5 mm (0.14 in.)		lb-in	4.34

The following tables show the cable types and wire sizes for the CN8 **3.81 pitch** removable screw terminal block of the embedded I/Os connector:

								
mm ²	0.14...1.5	0.14...1.5	0.25...1.5	0.25...0.5	2 x 0.14...0.5	2 x 0.14...0.75	2 x 0.25...0.34	2 x 0.5
AWG	26...16	26...16	22...16	22...20	2 x 26...20	2 x 26...20	2 x 24...22	2 x 20

		N•m	0.28
Ø 2,5 mm (0.1 in.)		lb-in	2.48

DANGER

LOOSE WIRING CAUSES ELECTRIC SHOCK

Tighten connections in conformance with the torque specifications.

Failure to follow these instructions will result in death or serious injury.

DANGER

FIRE HAZARD

Use only the correct wire sizes for the maximum current capacity of the power supplies.

Failure to follow these instructions will result in death or serious injury.

Protecting Outputs from Inductive Load Damage

Depending on the load, a protection circuit may be needed for the outputs on the controllers and certain modules. Inductive loads using DC voltages may create voltage reflections resulting in overshoot that will damage or shorten the life of output devices.

CAUTION

OUTPUT CIRCUIT DAMAGE DUE TO INDUCTIVE LOADS

Use an appropriate external protective circuit or device to reduce the risk of inductive direct current load damage.

Failure to follow these instructions can result in injury or equipment damage.

If your controller or module contains relay outputs, these types of outputs can support up to 240 Vac. Inductive damage to these types of outputs can result in welded contacts and loss of control. Each inductive load must include a protection

device such as a peak limiter, RC circuit or flyback diode. Capacitive loads are not supported by these relays.

⚠ WARNING
<p>RELAY OUTPUTS WELDED CLOSED</p> <ul style="list-style-type: none"> • Always protect relay outputs from inductive alternating current load damage using an appropriate external protective circuit or device. • Do not connect relay outputs to capacitive loads. <p>Failure to follow these instructions can result in death, serious injury, or equipment damage.</p>

AC-driven contactor coils are, under certain circumstances, inductive loads that generate pronounced high-frequency interference and electrical transients when the contactor coil is de-energized. This interference may cause the logic controller to detect an I/O bus error.

⚠ WARNING
<p>CONSEQUENTIAL LOSS OF CONTROL</p> <p>Install an RC surge suppressor or similar means, such as an interposing relay, on each TM3 expansion module relay output when connecting to AC-driven contactors or other forms of inductive loads.</p> <p>Failure to follow these instructions can result in death, serious injury, or equipment damage.</p>

Protective circuit A: this protection circuit can be used for both AC and DC load power circuits.

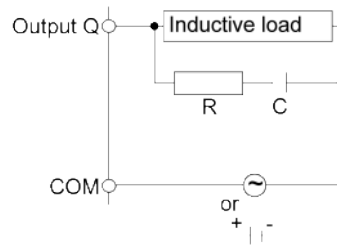

C Value from 0.1 to 1 μ F

R Resistor of approximately the same resistance value as the load

Protective circuit B: this protection circuit can be used for DC load power circuits.

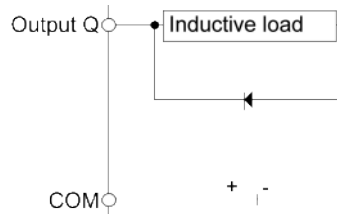

Use a diode with the following ratings:

- Reverse withstand voltage: power voltage of the load circuit x 10.
- Forward current: more than the load current.

Protective circuit C: this protection circuit can be used for both AC and DC load power circuits.

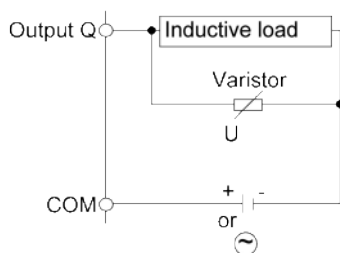

In applications where the inductive load is switched on and off frequently and/or rapidly, ensure that the continuous energy rating (J) of the varistor exceeds the peak load energy by 20 % or more.

DC Power Supply Characteristics and Wiring

Overview

This section provides the characteristics and the wiring diagrams of the DC power supply.

DC Power Supply Voltage Range

If the specified voltage range is not maintained, outputs may not switch as expected. Use appropriate safety interlocks and voltage monitoring circuits.

⚠ WARNING

UNINTENDED EQUIPMENT OPERATION

Do not exceed any of the rated values specified in the environmental and electrical characteristics tables.

Failure to follow these instructions can result in death, serious injury, or equipment damage.

DC Power Supply Requirements

The M262 Logic/Motion Controller requires a power supply with a nominal voltage of 24 Vdc. The 24 Vdc power supply must be rated Protective Extra Low Voltage (PELV) according to IEC 61140. This power supply is isolated between the electrical input and output circuits of the power supply.

⚠ WARNING

POTENTIAL OF OVERHEATING AND FIRE

- Do not connect the equipment directly to line voltage.
- Use only isolating PELV power supplies and circuits to supply power to the equipment¹.

Failure to follow these instructions can result in death, serious injury, or equipment damage.

¹ For compliance to UL (Underwriters Laboratories) requirements, the power supply must also conform to the various criteria of NEC Class 2, and be inherently current limited to a maximum power output availability of less than 100 VA (approximately 4 A at nominal voltage), or not inherently limited but with an additional protection device such as a circuit breaker or fuse meeting the

requirements of clause 9.4 Limited-energy circuit of UL 61010-1. In all cases, the current limit should never exceed that of the electric characteristics and wiring diagrams for the equipment described in the present documentation. In all cases, the power supply must be grounded, and you must separate Class 2 circuits from other circuits. If the indicated rating of the electrical characteristics or wiring diagrams are greater than the specified current limit, multiple Class 2 power supplies may be used.

Controller DC Characteristics

This table shows the characteristics of the DC power supply required for the controller:

Characteristic		Value
Rated voltage		24 Vdc
Power supply voltage range		20.4...28.8 Vdc (ripple \pm 10 % Un)
Power interruption time immunity		Min. 3 ms
Maximum inrush current		40 A
Maximum power consumption		82 W Including 25 W max. available for TM3 expansion modules Including 45 W max. available for TMS expansion modules
Isolation	between DC power supply and internal logic	Not isolated
	between DC power supply and grounding	780 Vdc
Reverse polarity protection		Yes

Power Interruption

The M262 Logic/Motion Controller must be supplied by an external 24 V power supply equipment. During power interruptions, the controller, associated to the suitable power supply, is able to continue normal operation for a minimum of 10 ms as specified by IEC standards.

When planning the management of the power supplied to the controller, you must consider the power interruption duration due to the fast cycle time of the controller.

There could potentially be many scans of the logic and consequential updates to the I/O image table during the power interruption, while there is no external power supplied to the inputs, the outputs or both depending on the power system architecture and power interruption circumstances.

⚠ WARNING
<p>UNINTENDED EQUIPMENT OPERATION</p> <ul style="list-style-type: none"> Individually monitor each source of power used in the controller system including input power supplies, output power supplies and the power supply to the controller to allow appropriate system shutdown during power system interruptions. The inputs monitoring each of the power supply sources must be unfiltered inputs. <p>Failure to follow these instructions can result in death, serious injury, or equipment damage.</p>

Controller DC Power Supply Wiring Diagram

The following figure shows the wiring of the controller DC power supply:

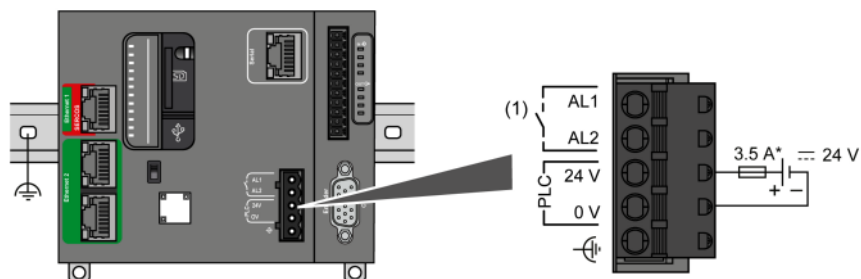

(1) Alarm Relay

* Type T fuse

For more information on wiring requirements, refer to the Rules for Terminal Blocks, page 56.

Grounding the M262 Logic/Motion Controller System

Functional Earth Ground (FE) on the DIN Rail

The DIN rail for your M262 Logic/Motion Controller controller is common with the functional earth ground (FE) plane and must be mounted on a conductive backplane.

⚠ WARNING

UNINTENDED EQUIPMENT OPERATION

Connect the DIN rail to the functional earth ground (FE) of your installation.

Failure to follow these instructions can result in death, serious injury, or equipment damage.

The connection between the functional earth ground (FE) and the M262 Logic/Motion Controller system is made by the DIN rail contacts on the back of the controller and the expansion modules.

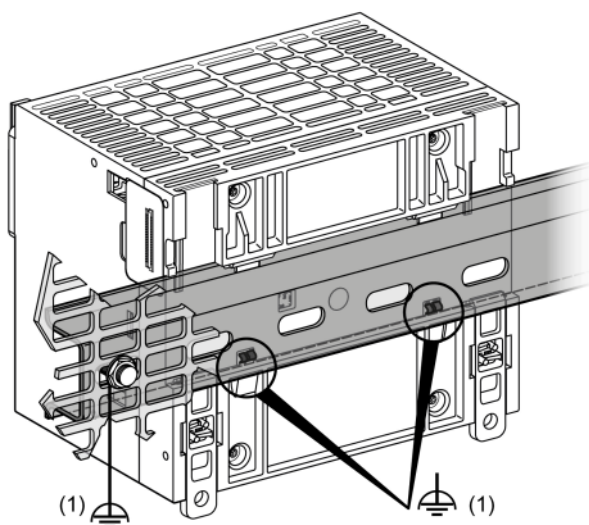

1 Functional earth ground (FE)

NOTE: When the M262 Logic/Motion Controller system is mounted on a DIN rail, the functional earth ground (FE) connector on the front face of the controller can be used to help minimize electromagnetic interference:

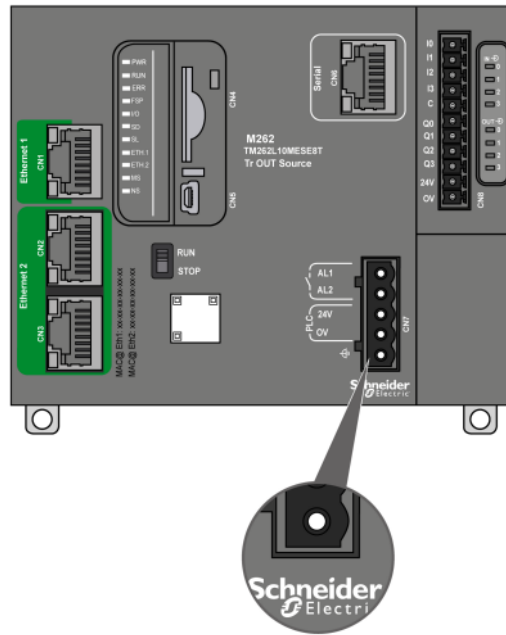

Protective Earth Ground (PE) on the Mounting Panel

The protective earth ground (PE) should be connected to the conductive mounting panel by a heavy-duty wire, usually a braided copper cable with the maximum allowable cable section.

Functional Earth Ground (FE) on the Mounting Panel

Use a functional ground cable to connect the functional ground connector to the conductive backplane:

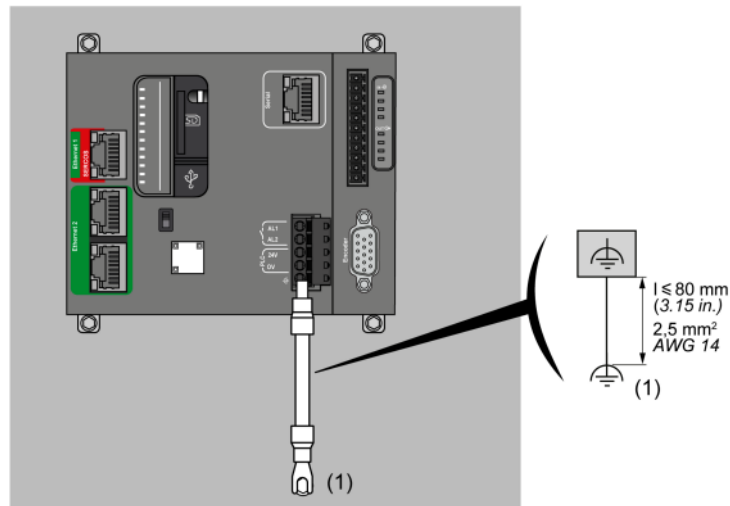

(1) Functional earth ground (FE)

The functional ground cable requires a cross-section of at least 1.5 mm² (AWG 16) and a maximum length of 80 mm (3.15 in.).

Shielded Cables Connections

To help minimize the effects of electromagnetic interference, cables carrying fieldbus communication signals must be shielded.

⚠ WARNING

UNINTENDED EQUIPMENT OPERATION

- Use shielded cables for communication signals.
- Ground cable shields for communication signals at a single point ¹.
- Always comply with local wiring requirements regarding grounding of cable shields.

Failure to follow these instructions can result in death, serious injury, or equipment damage.

¹Multipoint grounding is permissible if connections are made to an equipotential ground plane dimensioned to help avoid cable shield damage in the event of power system short-circuit currents.

The use of shielded cables requires compliance with the following wiring rules:

- For protective earth ground connections (PE), metal conduit or ducting can be used for part of the shielding length, provided there is no break in the continuity of the ground connections. For functional earth ground (FE), the shielding is intended to attenuate electromagnetic interference and the shielding must be continuous for the length of the cable. If the purpose is both functional and protective, as is often the case for communication cables, the cable must have continuous shielding.
- Wherever possible, keep cables carrying one type of signal separate from the cables carrying other types of signals or power.

The shielding must be securely connected to ground. The fieldbus communication cable shields must be connected to the protective earth ground (PE) with a connecting clamp secured to the conductive backplane of your installation.

The shielding of the following cables must be connected to the protective earth ground (PE):

- Ethernet (unless forbidden by an applicable standard)
- Serial
- Encoder (on TM262M• references)

The embedded I/O shields can be connected to either the protective earth ground (PE) or the functional earth ground (FE).

⚡⚠ DANGER

HAZARD OF ELECTRIC SHOCK

- The grounding terminal connection (PE) must be used to provide a protective ground at all times.
- Make sure that an appropriate, braided ground cable is attached to the PE/PG ground terminal before connecting or disconnecting the network cable to the equipment.

Failure to follow these instructions will result in death or serious injury.

⚠ WARNING

ACCIDENTAL DISCONNECTION FROM PROTECTIVE GROUND (PE)

- Do not use the Grounding Bar to provide a protective earth ground (PE).
- Use the Grounding Bar only to provide a functional earth ground (FE).

Failure to follow these instructions can result in death, serious injury, or equipment damage.

The figure below represents an M262 Logic/Motion Controller with shielded cables connected to a DIN rail:

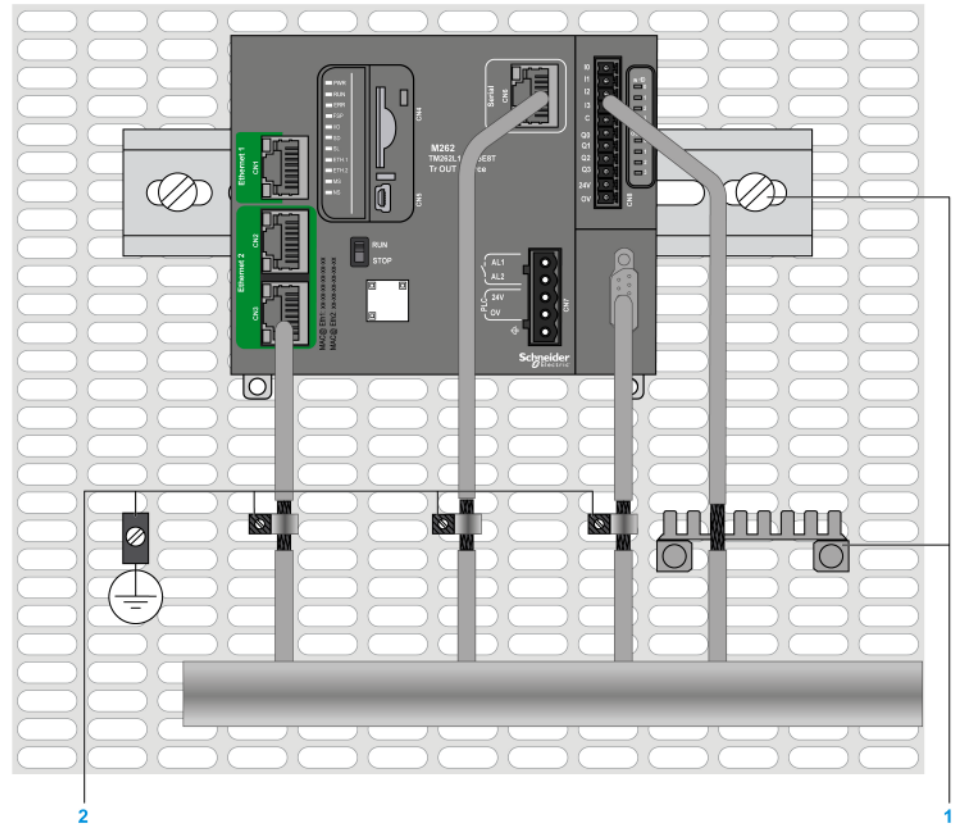

1 Functional earth ground (FE)

2 Protective earth ground (PE)

The figure below represents an M262 Logic/Motion Controller with shielded cables connected to a mounting panel:

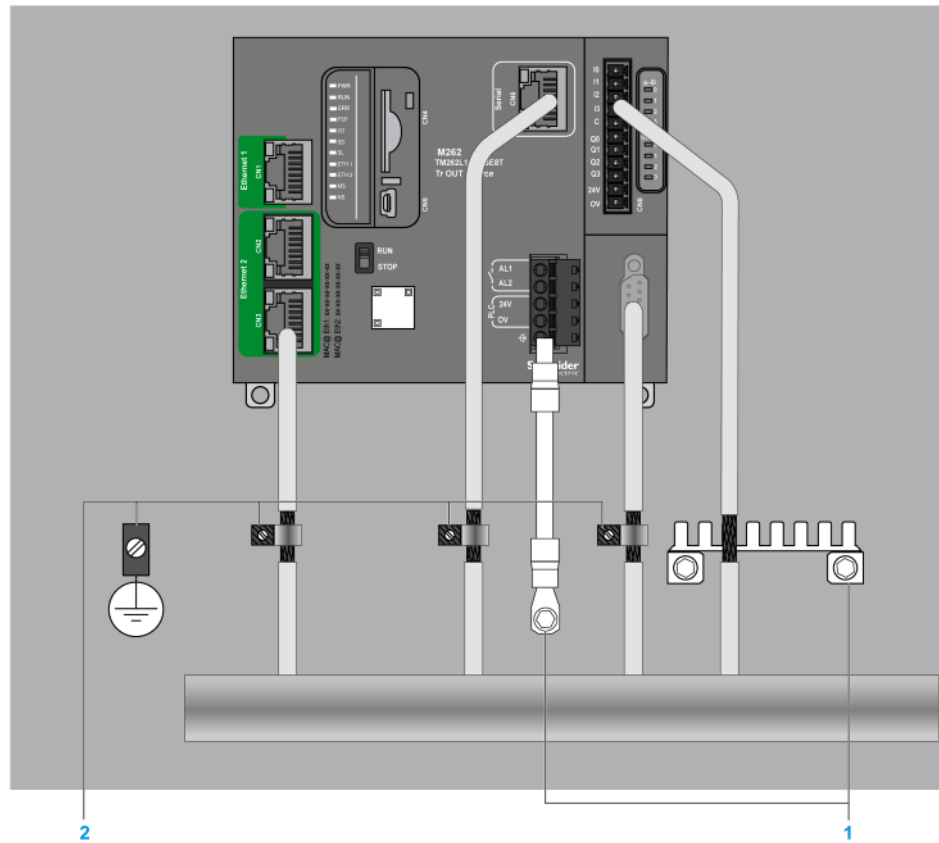

1 Functional earth ground (FE)

2 Protective earth ground (PE)

Protective Earth Ground (PE) Cable Shielding

To ground the shield of a cable via a grounding clamp:

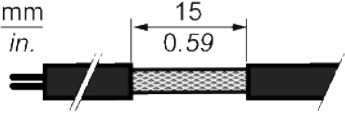
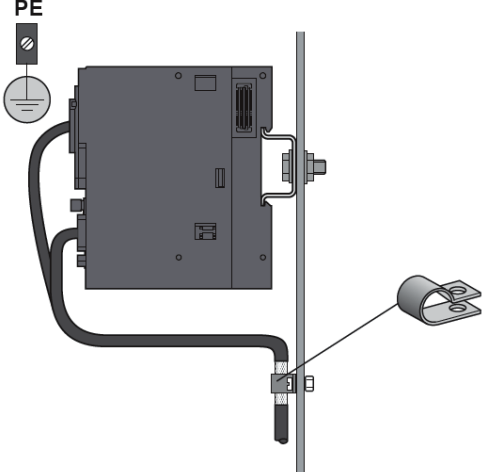
Step	Description	
1	Strip the shielding for a length of 15 mm (0.59 in.).	
2	Attach the cable to the conductive backplane plate by attaching the grounding clamp to the stripped part of the shielding as close as possible to the base of the M262 Logic/Motion Controller.	

NOTE: The shielding must be clamped securely to the conductive backplane to help ensure good contact.

Functional Earth Ground (FE) Cable Shielding

Connect the shield of a cable via the grounding bar:

Step	Description	
1	Install the grounding bar directly on the conductive backplane below the M262 Logic/Motion Controller as illustrated.	
2	Strip the shielding for a length of 15 mm (0.59 in.).	
3	Tightly clamp on the blade connector (1) using a nylon fastener (2) (width 2.5...3 mm (0.1...0.12 in.)) and appropriate tool.	

Alarm Relay Wiring

Overview

The M262 Logic/Motion Controller has integrated relay connections that can be wired to an external alarm.

Wiring Stripping and Wire Sizes

The alarm relay is wired by means of a 5.08 mm pitch removable screw terminal block on the front face of the M262 Logic/Motion Controller. For details, refer to Rules for Terminal Blocks, page 56.

Using the Alarm Relay for the Actuator Power Supply

Proceed as follows to use the Alarm relay for the actuator power supply:

Step	Action
1	Switch on the power supply of the M262 Logic/Motion Controller using the main contactor.
2	When the M262 Logic/Motion Controller is powered on, switch on the output power supply for the actuators using the KA contactor. The following wiring diagram shows an M262 Logic/Motion Controller supplied by direct current:

In AUTO run mode, the KA contactor is controlled by the alarm relay from the power supply module.

If your system comprises multiple M262 Logic/Motion Controllers installed in multiple racks, set the alarm relay contacts in all controllers in series (AL0, AL1, AL2, and so on), as shown in the following diagram:

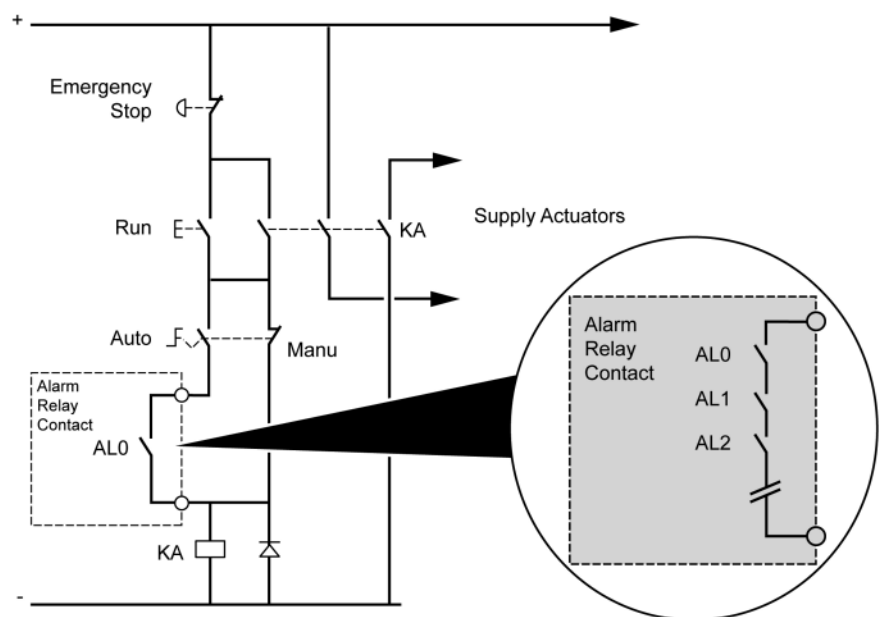

Modicon M262 Logic/Motion Controller

TM262L01MESE8T Presentation

Overview

The TM262L01MESE8T logic controller has:

- 4 fast digital inputs
- 4 fast digital outputs (source)
- Communication ports:
 - 1 serial line port
 - 1 USB mini-B programming port
 - 2 Ethernet switched ports
 - 1 Ethernet port

Description

The following figure shows the different components of the TM262L01MESE8T logic controller:

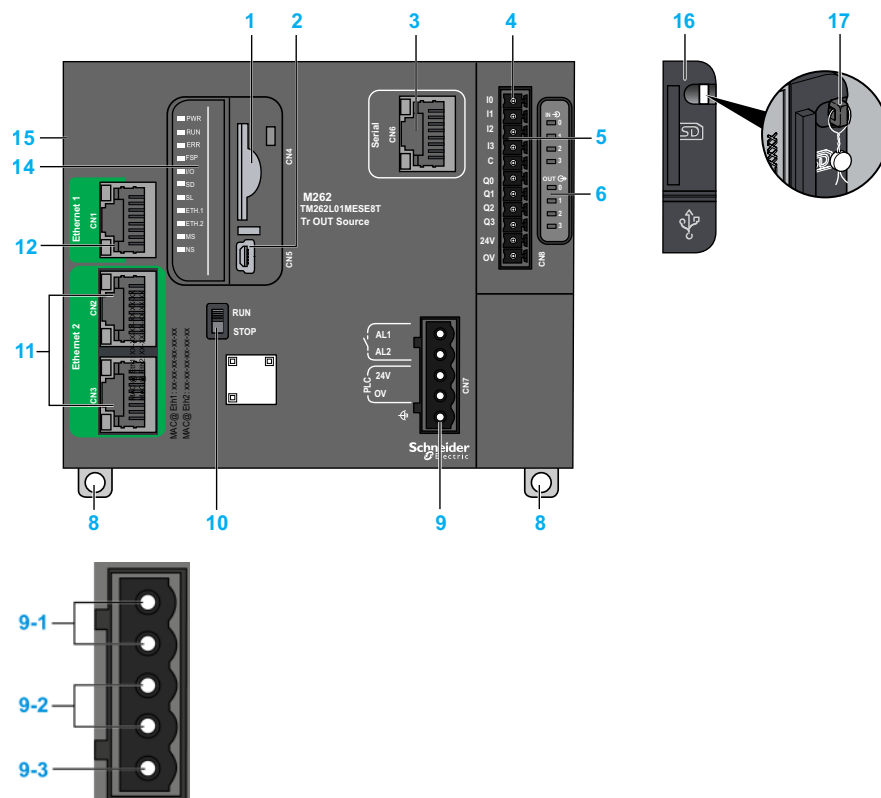

N°	Description	Refer to
1	SD card slot	SD Card, page 36
2	USB mini-B programming port (for terminal connection to a programming PC)	USB Mini-B Programming Port , page 119
3	Serial line port (type RJ45 (RS-232 or RS-485))	Serial Line, page 121
4	Inputs/outputs terminal connector	Embedded Digital Inputs, page 103
		Embedded Digital Outputs, page 106
5	TM3 bus connector	TM3 Expansion Modules, page 20
6	I/O status LEDs	Fast Inputs Status LEDs, page 105
		Fast Outputs Status LEDs, page 108
8	Clip-on lock for 35 mm (1.38 in.) top hat section rail (DIN rail)	Top Hat Section Rail (DIN rail), page 49
9-1	Alarm relay terminal connector	Alarm Relay, page 40
9-2	24 Vdc power supply	DC Power supply Characteristics and Wiring, page 58
9-3	Functional Earth (FE) grounding connection	Grounding the M262 Logic/Motion Controller, page 60
10	Run/Stop switch	Run/Stop, page 35
11	Dual port Ethernet switch	Ethernet 2 port, page 117
12	Ethernet port 1	Ethernet 1 port, page 115
14	Status LEDs	See below
15	TMS bus connector	TMS Expansion Modules (see Modicon M262 Logic/Motion Controller, Programming Guide)
16	Protective cover (for SD card slot and USB mini-B programming port)	-
17	Locking hook (optional lock not included)	-

Status LEDs

This figure shows the status LEDs:

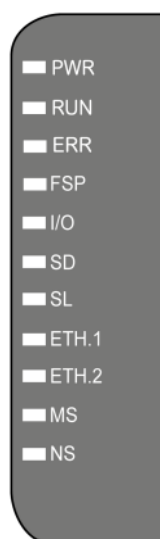

The following table describes the system status LEDs:

Label	Function Type	Color	Status	Description
PWR	Power	Green/Red	Green OFF/Red OFF	Indicates that power is removed.
			Green ON/Red OFF	Indicates that power is applied, normal operation.
			Green ON/Red 1 flash	Elevated internal operating temperature detected (over 80 °C (176 °F)). Take appropriate measures to reduce the temperature.
			Green ON/Red 2 flashes	Detected error on TM3 power.
			Green ON/Red 3 flashes	Detected error on TMS power.
			Green ON/Red 4 flashes	Detected error on Serial line power.
RUN	Machine status	Green	ON	Indicates that the controller is running a valid application.
			Regular flash	Indicates that the controller is running a valid application that is stopped.
			Single flash	Indicates that the controller is running a valid application that is stopped at a breakpoint.
			OFF	Indicates that the controller does not contain a valid application.
ERR	Internal Error	Red	ON	Indicates that an application error (exception) has been detected. The RUN LED is flashing to indicate that the application is stopped.
			Fast flash	Indicates that the controller has detected a firmware error.
			Regular flash	Indicates either that a minor error has been detected if RUN is ON or flashing regularly, or that no application has been detected if RUN is OFF.
FSP	Forced stop	Red	ON	Indicates that the Run/Stop switch or Run/stop input has been activated to force the controller to the STOPPED state.
			Regular flash	Indicates that at least one application variable is being forced.
I/O	I/O error	Red	ON	Indicates that I/O or expansion module errors have been detected. More details on the error detected are provided by: <ul style="list-style-type: none"> The system variables <i>i_lwSystemFault_1</i> and <i>i_lwSystemFault_2</i> (see Modicon M262 Logic/Motion Controller, System Functions and Variables, System Library Guide) The Diagnostics > Controller submenu of the Web Server (see Modicon M262 Logic/Motion Controller, Programming Guide)
SD	SD card access	Green	ON	Indicates that a firmware update is completed.
		Green	Regular flash	Indicates that a firmware update or script execution is in progress.
		Yellow	ON	Indicates that a firmware update or script execution is unsuccessful. <p>NOTE: If the script file is not executed, a log file is generated. The log file location in the controller is <i>/usr/Syslog/FWLog.txt</i>.</p>
		Yellow	Regular flash	Indicates that the SD card is being accessed (script execution in progress).
		-	OFF	No SD card activity.
SL	Serial line	Yellow	Flashing	Indicates communication on the serial line.
			OFF	Indicates no serial communication.

Label	Function Type	Color	Status	Description
ETH.1 ETH.2	Ethernet port status	Green	ON	Indicates that the Ethernet port is connected and the IP address is defined.
			3 flashes	Indicates that the Ethernet port is not connected.
			4 flashes	Address conflict detected. Indicates that the configured IP address is already in use.
			5 flashes	Indicates that the address is the default address. The module is waiting for a BOOTP or DHCP sequence.
			6 flashes	Indicates that the configured IP address is not valid. The default IP address is being used.
			OFF	Indicates that the Ethernet port is not configured.
MS	EtherNet/IP controller interface status	Red	ON	Indicates that an unrecoverable error has been detected.
			Regular flash	Indicates that a recoverable error has been detected.
		Green	ON	Indicates that the controller interface is functioning normally.
			Regular flash	Indicates that the configuration is missing, incomplete, incorrect or unused.
		Red/Green	Regular flash	Indicates that an error has been detected.
		-	OFF	Indicates that the controller is powered off.
NS	EtherNet/IP network status	Red	ON	Indicates that one or more connections timed out, or that an error is preventing network communications (duplicate IP address, or bus powered off).
			Regular flash	Indicates that a recoverable error has been detected, for example, one or more connections timed out.
		Green	ON	Indicates that the controller interface is functioning normally and network connections are established.
			Regular flash	Indicates that the controller interface is operating normally, but network connections have not been established, or the network configuration is missing, incomplete, or incorrect.
		Red/Green	Regular flash	Indicates that an error has been detected.
		-	OFF	Indicates that the controller is powered off, or is powered on with no IP address configured.

This timing diagram shows the difference between the fast flash, regular flash and single flash:

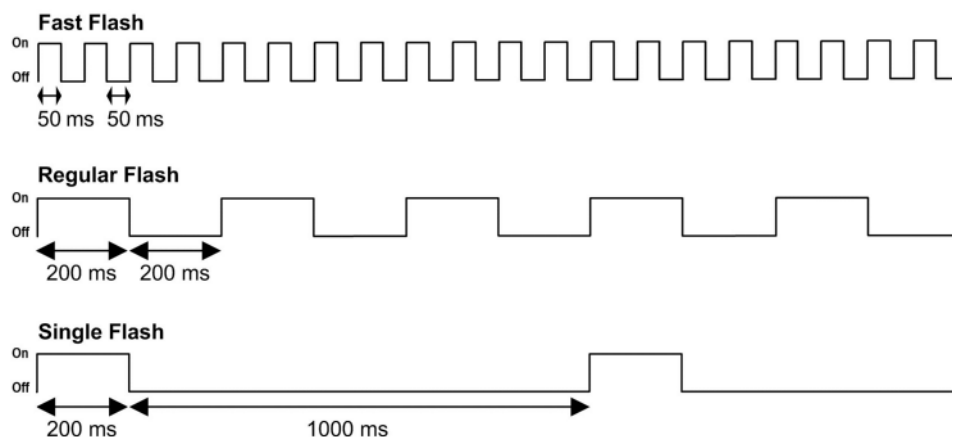

Dimensions

The following figure shows the external dimensions of the TM262L01MESE8T logic controller:

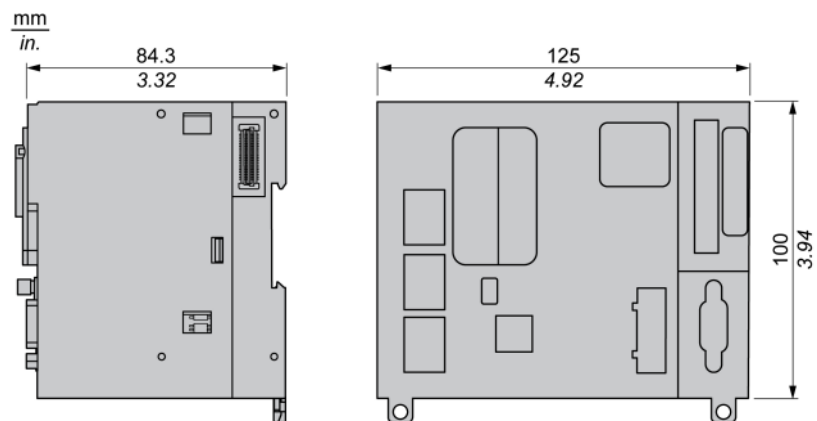

Weight

655 g

TM262L10MESE8T Presentation

Overview

The TM262L10MESE8T logic controller has:

- 4 fast digital inputs
- 4 fast digital outputs (source)
- Communication ports:
 - 1 serial line port
 - 1 USB mini-B programming port
 - 2 Ethernet switched ports
 - 1 Ethernet port

Description

The following figure shows the different components of the TM262L10MESE8T logic controller:

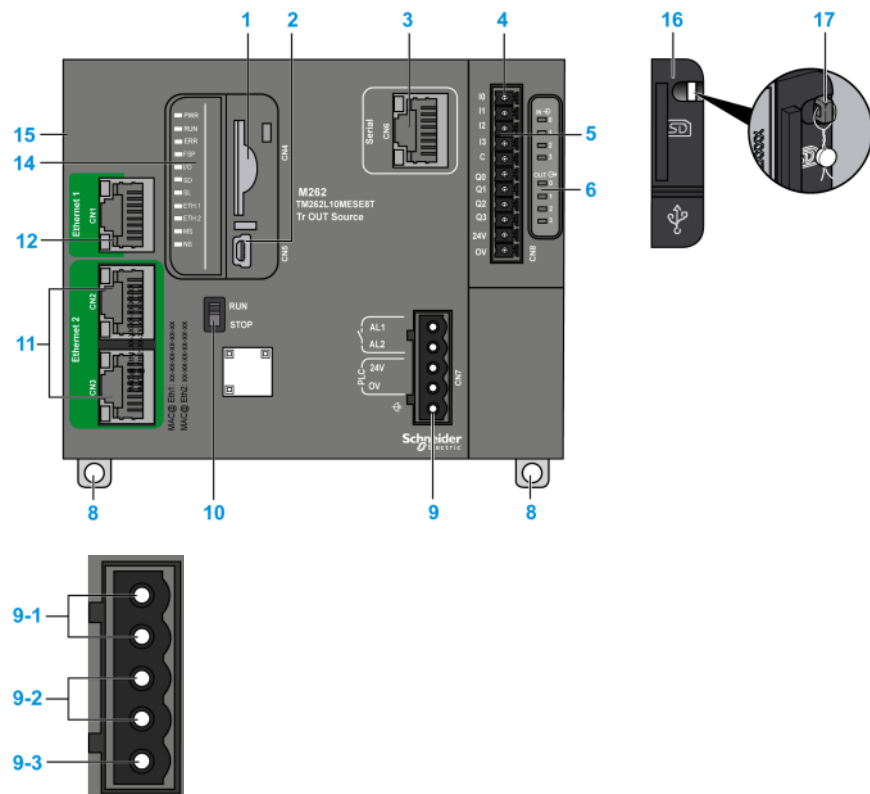

N°	Description	Refer to
1	SD card slot	SD Card, page 36
2	USB mini-B programming port (for terminal connection to a programming PC)	USB Mini-B Programming Port , page 119
3	Serial line port (type RJ45 (RS-232 or RS-485))	Serial Line, page 121
4	Inputs/outputs terminal connector	Embedded Digital Inputs, page 103
		Embedded Digital Outputs, page 106
5	TM3 bus connector	TM3 Expansion Modules, page 20
6	I/O status LEDs	Fast Inputs Status LEDs, page 105
		Fast Outputs Status LEDs, page 108
8	Clip-on lock for 35 mm (1.38 in.) top hat section rail (DIN rail)	Top Hat Section Rail (DIN rail), page 49
9-1	Alarm relay terminal connector	Alarm Relay, page 40
9-2	24 Vdc power supply	DC Power supply Characteristics and Wiring, page 58
9-3	Functional Earth (FE) grounding connection	Grounding the M262 Logic/Motion Controller, page 60
10	Run/Stop switch	Run/Stop, page 35
11	Dual port Ethernet switch	Ethernet 2 port, page 117
12	Ethernet port 1	Ethernet 1 port, page 115
14	Status LEDs	See below
15	TMS bus connector	TMS Expansion Modules (see Modicon M262 Logic/Motion Controller, Programming Guide)
16	Protective cover (for SD card slot and USB mini-B programming port)	-
17	Locking hook (optional lock not included)	-

Status LEDs

This figure shows the status LEDs:

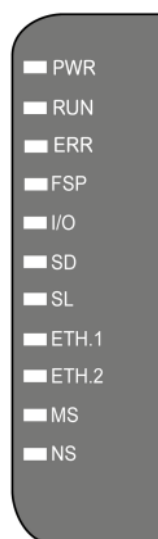

The following table describes the system status LEDs:

Label	Function Type	Color	Status	Description
PWR	Power	Green/Red	Green OFF/Red OFF	Indicates that power is removed.
			Green ON/Red OFF	Indicates that power is applied, normal operation.
			Green ON/Red 1 flash	Elevated internal operating temperature detected (over 80 °C (176 °F)). Take appropriate measures to reduce the temperature.
			Green ON/Red 2 flashes	Detected error on TM3 power.
			Green ON/Red 3 flashes	Detected error on TMS power.
			Green ON/Red 4 flashes	Detected error on Serial line power.
RUN	Machine status	Green	ON	Indicates that the controller is running a valid application.
			Regular flash	Indicates that the controller is running a valid application that is stopped.
			Single flash	Indicates that the controller is running a valid application that is stopped at a breakpoint.
			OFF	Indicates that the controller does not contain a valid application.
ERR	Internal Error	Red	ON	Indicates that an application error (exception) has been detected. The RUN LED is flashing to indicate that the application is stopped.
			Fast flash	Indicates that the controller has detected a firmware error.
			Regular flash	Indicates either that a minor error has been detected if RUN is ON or flashing regularly, or that no application has been detected if RUN is OFF.
FSP	Forced stop	Red	ON	Indicates that the Run/Stop switch or Run/stop input has been activated to force the controller to the STOPPED state.
			Regular flash	Indicates that at least one application variable is being forced.
I/O	I/O error	Red	ON	Indicates that I/O or expansion module errors have been detected. More details on the error detected are provided by: <ul style="list-style-type: none"> The system variables <i>i_lwSystemFault_1</i> and <i>i_lwSystemFault_2</i> (see Modicon M262 Logic/Motion Controller, System Functions and Variables, System Library Guide) The Diagnostics > Controller submenu of the Web Server (see Modicon M262 Logic/Motion Controller, Programming Guide)
SD	SD card access	Green	ON	Indicates that a firmware update is completed.
		Green	Regular flash	Indicates that a firmware update or script execution is in progress.
		Yellow	ON	Indicates that a firmware update or script execution is unsuccessful. <p>NOTE: If the script file is not executed, a log file is generated. The log file location in the controller is <i>/usr/Syslog/FWLog.txt</i>.</p>
		Yellow	Regular flash	Indicates that the SD card is being accessed (script execution in progress).
		-	OFF	No SD card activity.
SL	Serial line	Yellow	Flashing	Indicates communication on the serial line.
			OFF	Indicates no serial communication.

Label	Function Type	Color	Status	Description
ETH.1 ETH.2	Ethernet port status	Green	ON	Indicates that the Ethernet port is connected and the IP address is defined.
			3 flashes	Indicates that the Ethernet port is not connected.
			4 flashes	Address conflict detected. Indicates that the configured IP address is already in use.
			5 flashes	Indicates that the address is the default address. The module is waiting for a BOOTP or DHCP sequence.
			6 flashes	Indicates that the configured IP address is not valid. The default IP address is being used.
			OFF	Indicates that the Ethernet port is not configured.
MS	EtherNet/IP controller interface status	Red	ON	Indicates that an unrecoverable error has been detected.
			Regular flash	Indicates that a recoverable error has been detected.
		Green	ON	Indicates that the controller interface is functioning normally.
			Regular flash	Indicates that the configuration is missing, incomplete, incorrect or unused.
		Red/Green	Regular flash	Indicates that an error has been detected.
-	OFF	Indicates that the controller is powered off.		
NS	EtherNet/IP network status	Red	ON	Indicates that one or more connections timed out, or that an error is preventing network communications (duplicate IP address, or bus powered off).
			Regular flash	Indicates that a recoverable error has been detected, for example, one or more connections timed out.
		Green	ON	Indicates that the controller interface is functioning normally and network connections are established.
			Regular flash	Indicates that the controller interface is operating normally, but network connections have not been established, or the network configuration is missing, incomplete, or incorrect.
		Red/Green	Regular flash	Indicates that an error has been detected.
		-	OFF	Indicates that the controller is powered off, or is powered on with no IP address configured.

This timing diagram shows the difference between the fast flash, regular flash and single flash:

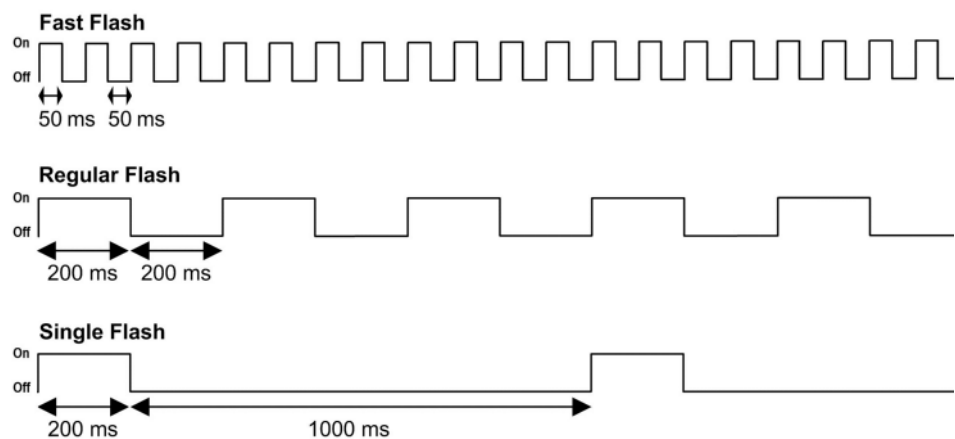

Dimensions

The following figure shows the external dimensions of the TM262L10MESE8T logic controller:

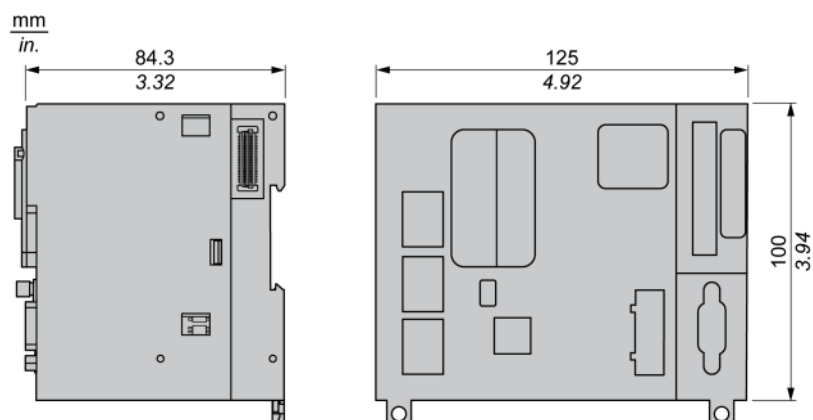

Weight

655 g

TM262L20MESE8T Presentation

Overview

The TM262L20MESE8T logic controller has:

- 4 fast digital inputs
- 4 fast digital outputs (source)
- Communication ports:
 - 1 serial line port
 - 1 USB mini-B programming port
 - 2 Ethernet switched ports
 - 1 Ethernet port

Description

The following figure shows the different components of the TM262L20MESE8T logic controller:

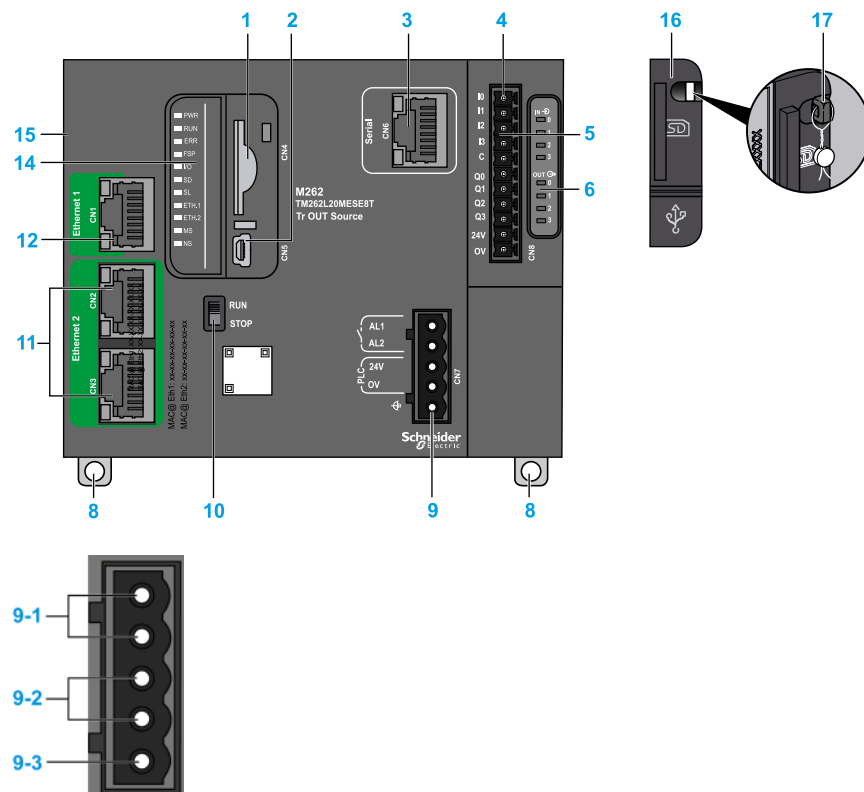

N°	Description	Refer to
1	SD card slot	SD Card, page 36
2	USB mini-B programming port (for terminal connection to a programming PC)	USB Mini-B Programming Port , page 119
3	Serial line port (type RJ45 (RS-232 or RS-485))	Serial Line, page 121
4	Inputs/outputs terminal connector	Embedded Digital Inputs, page 103
		Embedded Digital Outputs, page 106
5	TM3 bus connector	TM3 Expansion Modules, page 20
6	I/O status LEDs	Fast Inputs Status LEDs, page 105
		Fast Outputs Status LEDs, page 108
8	Clip-on lock for 35 mm (1.38 in.) top hat section rail (DIN rail)	Top Hat Section Rail (DIN rail), page 49
9-1	Alarm relay terminal connector	Alarm Relay, page 40
9-2	24 Vdc power supply	DC Power supply Characteristics and Wiring, page 58
9-3	Functional Earth (FE) grounding connection	Grounding the M262 Logic/Motion Controller, page 60
10	Run/Stop switch	Run/Stop, page 35
11	Dual port Ethernet switch	Ethernet 2 port, page 117
12	Ethernet port 1	Ethernet 1 port, page 115
14	Status LEDs	See below
15	TMS bus connector	TMS Expansion Modules (see Modicon M262 Logic/Motion Controller, Programming Guide)
16	Protective cover (for SD card slot and USB mini-B programming port)	-
17	Locking hook (optional lock not included)	-

Status LEDs

This figure shows the status LEDs:



The following table describes the system status LEDs:

Label	Function Type	Color	Status	Description
PWR	Power	Green/Red	Green OFF/Red OFF	Indicates that power is removed.
			Green ON/Red OFF	Indicates that power is applied, normal operation.
			Green ON/Red 1 flash	Elevated internal operating temperature detected (over 80 °C (176 °F)). Take appropriate measures to reduce the temperature.
			Green ON/Red 2 flashes	Detected error on TM3 power.
			Green ON/Red 3 flashes	Detected error on TMS power.
			Green ON/Red 4 flashes	Detected error on Serial line power.
RUN	Machine status	Green	ON	Indicates that the controller is running a valid application.
			Regular flash	Indicates that the controller is running a valid application that is stopped.
			Single flash	Indicates that the controller is running a valid application that is stopped at a breakpoint.
			OFF	Indicates that the controller does not contain a valid application.
ERR	Internal Error	Red	ON	Indicates that an application error (exception) has been detected. The RUN LED is flashing to indicate that the application is stopped.
			Fast flash	Indicates that the controller has detected a firmware error.
			Regular flash	Indicates either that a minor error has been detected if RUN is ON or flashing regularly, or that no application has been detected if RUN is OFF.
FSP	Forced stop	Red	ON	Indicates that the Run/Stop switch or Run/stop input has been activated to force the controller to the STOPPED state.
			Regular flash	Indicates that at least one application variable is being forced.
I/O	I/O error	Red	ON	Indicates that I/O or expansion module errors have been detected. More details on the error detected are provided by: <ul style="list-style-type: none"> The system variables <i>i_lwSystemFault_1</i> and <i>i_lwSystemFault_2</i> (see Modicon M262 Logic/Motion Controller, System Functions and Variables, System Library Guide) The Diagnostics > Controller submenu of the Web Server (see Modicon M262 Logic/Motion Controller, Programming Guide)
SD	SD card access	Green	ON	Indicates that a firmware update is completed.
		Green	Regular flash	Indicates that a firmware update or script execution is in progress.
		Yellow	ON	Indicates that a firmware update or script execution is unsuccessful. <p>NOTE: If the script file is not executed, a log file is generated. The log file location in the controller is <i>/usr/Syslog/FWLog.txt</i>.</p>
		Yellow	Regular flash	Indicates that the SD card is being accessed (script execution in progress).
		-	OFF	No SD card activity.
SL	Serial line	Yellow	Flashing	Indicates communication on the serial line.
			OFF	Indicates no serial communication.

Label	Function Type	Color	Status	Description
ETH.1 ETH.2	Ethernet port status	Green	ON	Indicates that the Ethernet port is connected and the IP address is defined.
			3 flashes	Indicates that the Ethernet port is not connected.
			4 flashes	Address conflict detected. Indicates that the configured IP address is already in use.
			5 flashes	Indicates that the address is the default address. The module is waiting for a BOOTP or DHCP sequence.
			6 flashes	Indicates that the configured IP address is not valid. The default IP address is being used.
			OFF	Indicates that the Ethernet port is not configured.
MS	EtherNet/IP controller interface status	Red	ON	Indicates that an unrecoverable error has been detected.
			Regular flash	Indicates that a recoverable error has been detected.
		Green	ON	Indicates that the controller interface is functioning normally.
			Regular flash	Indicates that the configuration is missing, incomplete, incorrect or unused.
		Red/Green	Regular flash	Indicates that an error has been detected.
		-	OFF	Indicates that the controller is powered off.
NS	EtherNet/IP network status	Red	ON	Indicates that one or more connections timed out, or that an error is preventing network communications (duplicate IP address, or bus powered off).
			Regular flash	Indicates that a recoverable error has been detected, for example, one or more connections timed out.
		Green	ON	Indicates that the controller interface is functioning normally and network connections are established.
			Regular flash	Indicates that the controller interface is operating normally, but network connections have not been established, or the network configuration is missing, incomplete, or incorrect.
		Red/Green	Regular flash	Indicates that an error has been detected.
		-	OFF	Indicates that the controller is powered off, or is powered on with no IP address configured.

This timing diagram shows the difference between the fast flash, regular flash and single flash:

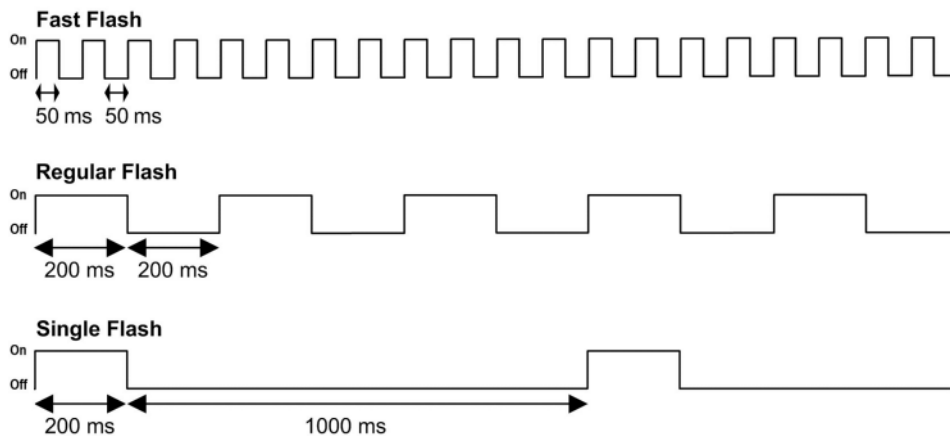

Dimensions

The following figure shows the external dimensions of the TM262L20MESE8T logic controller:

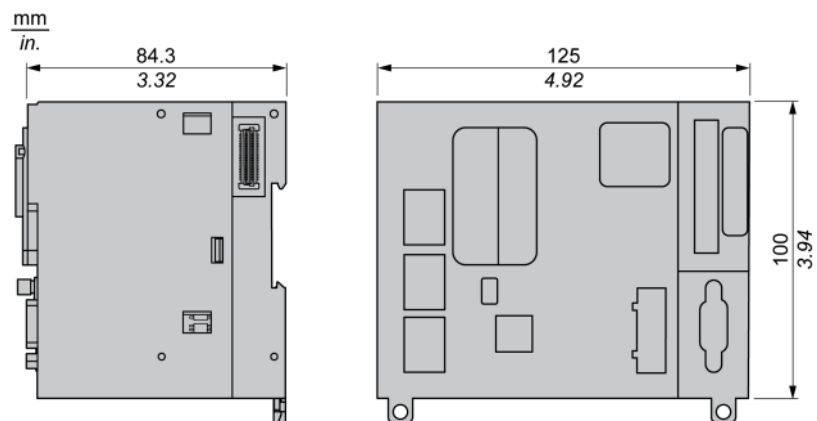

Weight

655 g

TM262M05MESS8T Presentation

Overview

The TM262M05MESS8T motion controller has:

- 4 fast digital inputs
- 4 fast digital outputs (source)
- Communication ports:
 - 1 serial line port
 - 1 USB mini-B programming port
 - 2 Ethernet switched ports
 - 1 Ethernet port for fieldbus with Sercos interface
- Encoder interface (SSI/incremental)

Description

The following figure shows the different components of the TM262M05MESS8T motion controller:

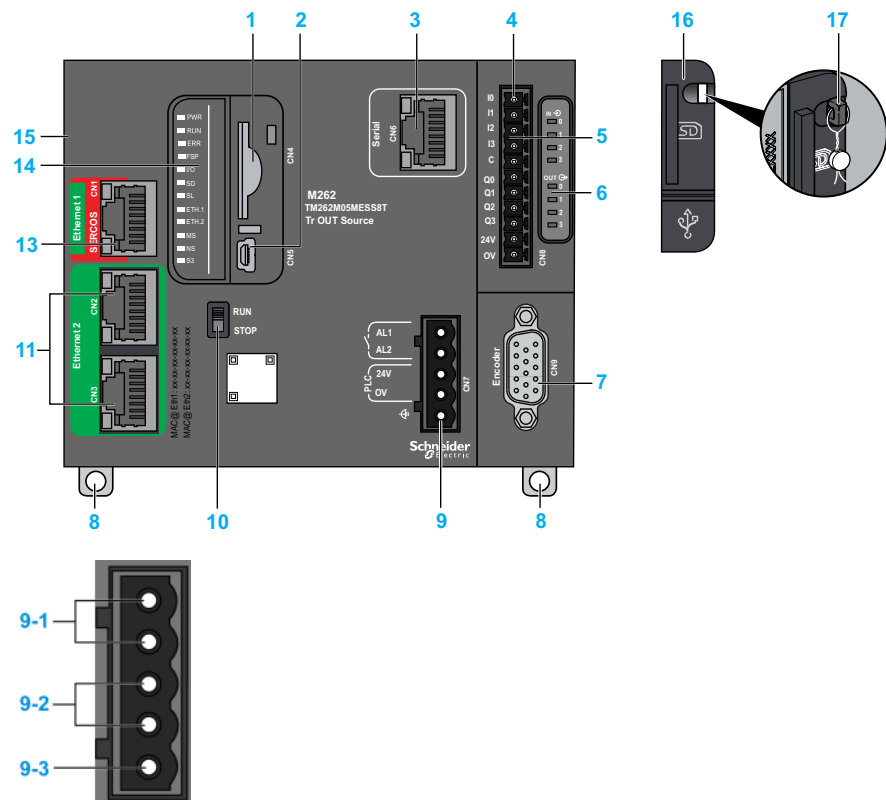

N°	Description	Refer to
1	SD card slot	SD Card, page 36
2	USB mini-B programming port (for terminal connection to a programming PC)	USB Mini-B Programming Port, page 119
3	Serial line port (type RJ45 (RS-232 or RS-485))	Serial Line, page 121
4	Inputs/outputs terminal connector	Embedded Digital Inputs, page 103
		Embedded Digital Outputs, page 106
5	TM3 bus connector	TM3 Expansion Modules, page 20
6	I/O status LEDs	Fast Inputs Status LEDs, page 105
		Fast Outputs Status LEDs, page 105
7	Encoder connector	Encoder Interface, page 110
8	Clip-on lock for 35 mm (1.38 in.) top hat section rail (DIN rail)	Top Hat Section Rail (DIN rail), page 49
9-1	Alarm relay terminal connector	Alarm Relay, page 40
9-2	24 Vdc power supply	DC Power supply Characteristics and Wiring, page 58
9-3	Functional Earth (FE) grounding connection	Grounding the M262 Logic/Motion Controller, page 60
10	Run/Stop switch	Run/Stop, page 35
11	Dual port Ethernet switch	Ethernet 2 Port, page 117
13	Ethernet 1 / Sercos port	Ethernet 1 Port, page 115
14	Status LEDs	See below
15	TMS bus connector	TMS Expansion Modules (see Modicon M262 Logic/Motion Controller, Programming Guide)
16	Protective cover (for SD card slot and USB mini-B programming port)	-
17	Locking hook (optional lock not included)	-

Status LEDs

This figure shows the status LEDs:

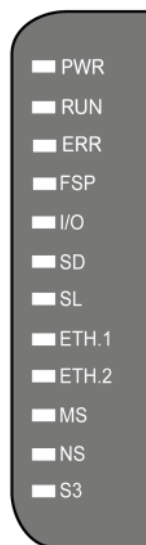

The following table describes the system status LEDs:

Label	Function Type	Color	Status	Description
PWR	Power	Green/Red	Green OFF/Red OFF	Indicates that power is removed.
			Green ON/Red OFF	Indicates that power is applied, normal operation.
			Green ON/Red 1 flash	Elevated internal operating temperature detected (over 80 °C (176 °F)). Take appropriate measures to reduce the temperature.
			Green ON/Red 2 flashes	Detected error on TM3 power.
			Green ON/Red 3 flashes	Detected error on TMS power.
			Green ON/Red 4 flashes	Detected error on Serial line power.
RUN	Machine status	Green	ON	Indicates that the controller is running a valid application.
			Regular flash	Indicates that the controller is running a valid application that is stopped.
			Single flash	Indicates that the controller is running a valid application that is stopped at a breakpoint.
			OFF	Indicates that the controller does not contain a valid application.
ERR	Internal Error	Red	ON	Indicates that an operating system error has been detected. The RUN LED is flashing to indicate that the application is stopped.
			Fast flash	Indicates that the controller has detected a firmware or hardware error.
			Regular flash	Indicates either that a minor error has been detected if RUN is ON or flashing, or that no application has been detected if RUN is OFF.
FSP	Forced stop	Red	ON	Indicates that the Run/Stop switch or Run/stop input has been activated to force the controller to the STOPPED state.
			Regular flash	Indicates that at least one application variable is being forced.
I/O	I/O error	Red	ON	Indicates that I/O or expansion module errors have been detected. More details on the error detected are provided by: <ul style="list-style-type: none"> The system variables <i>i_IwSystemFault_1</i> and <i>i_IwSystemFault_2</i> (see Modicon M262 Logic/Motion Controller, System Functions and Variables, System Library Guide) The Diagnostics > Controller submenu of the Web Server (see Modicon M262 Logic/Motion Controller, Programming Guide)
SD	SD card access	Green	ON	Indicates that a firmware update is completed.
		Green	Regular flash	Indicates that a firmware update or script execution is in progress.
		Yellow	ON	Indicates that a firmware update or script execution is unsuccessful. NOTE: If the script file is not executed, a log file is generated. The log file location in the controller is <i>/usr/Syslog/FWLog.txt</i> .
		Yellow	Regular flash	Indicates that the SD card is being accessed (script execution in progress).
		-	OFF	No SD card activity.
SL	Serial line	Yellow	Flashing	Indicates communication on the serial line.
			OFF	Indicates no serial communication.

Label	Function Type	Color	Status	Description
ETH.1 ETH.2	Ethernet port status	Green	ON	Indicates that the Ethernet port is connected and the IP address is defined.
			3 flashes	Indicates that the Ethernet port is not connected.
			4 flashes	Address conflict detected. Indicates that the configured IP address is already in use.
			5 flashes	Indicates that the address is the default address. The module is waiting for a BOOTP or DHCP sequence.
			6 flashes	Indicates that the configured IP address is not valid. The default IP address is being used.
			OFF	Indicates that the Ethernet port is not configured.
MS	EtherNet/IP controller interface status	Red	ON	Indicates that an unrecoverable error has been detected.
			Regular flash	Indicates that a recoverable error has been detected.
		Green	ON	Indicates that the controller interface is functioning normally.
			Regular flash	Indicates that the configuration is missing, incomplete, incorrect or unused.
		Red/Green	Regular flash	Indicates that an error has been detected.
-	OFF	Indicates that the controller is powered off.		
NS	EtherNet/IP network status	Red	ON	Indicates that one or more connections timed out, or that an error is preventing network communications (duplicate IP address, or bus powered off).
			Regular flash	Indicates that a recoverable error has been detected, for example, one or more connections timed out.
		Green	ON	Indicates that the controller interface is functioning normally and network connections are established.
			Regular flash	Indicates that the controller interface is operating normally, but network connections have not been established, or the network configuration is missing, incomplete, or incorrect.
		Red/Green	Regular flash	Indicates that an error has been detected.
		-	OFF	Indicates that the controller is powered off, or is powered on with no IP address configured.
S3	Sercos 3 master status	-	OFF	No Sercos 3 communication.
		Orange	ON	Sercos 3 initialization (phase-up) in progress.
		Green	ON	Sercos 3 operational.
		Red	ON	Sercos 3 error.

This timing diagram shows the difference between the fast flash, regular flash and single flash:

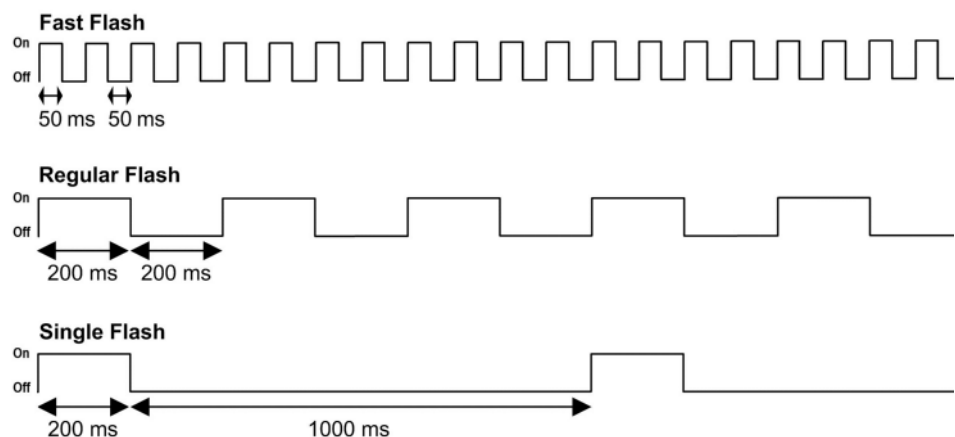

Dimensions

The following figure shows the external dimensions of the TM262M05MESS8T motion controller:

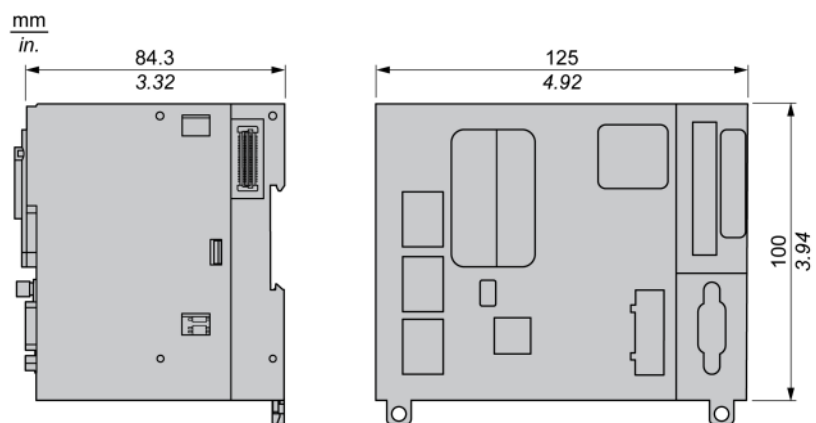

Weight

670 g

TM262M15MESS8T Presentation

Overview

The TM262M15MESS8T motion controller has:

- 4 fast digital inputs
- 4 fast digital outputs (source)
- Communication ports:
 - 1 serial line port
 - 1 USB mini-B programming port
 - 2 Ethernet switched ports
 - 1 Ethernet port for fieldbus with Sercos interface
- Encoder interface (SSI/incremental)

Description

The following figure shows the different components of the TM262M15MESS8T motion controller:

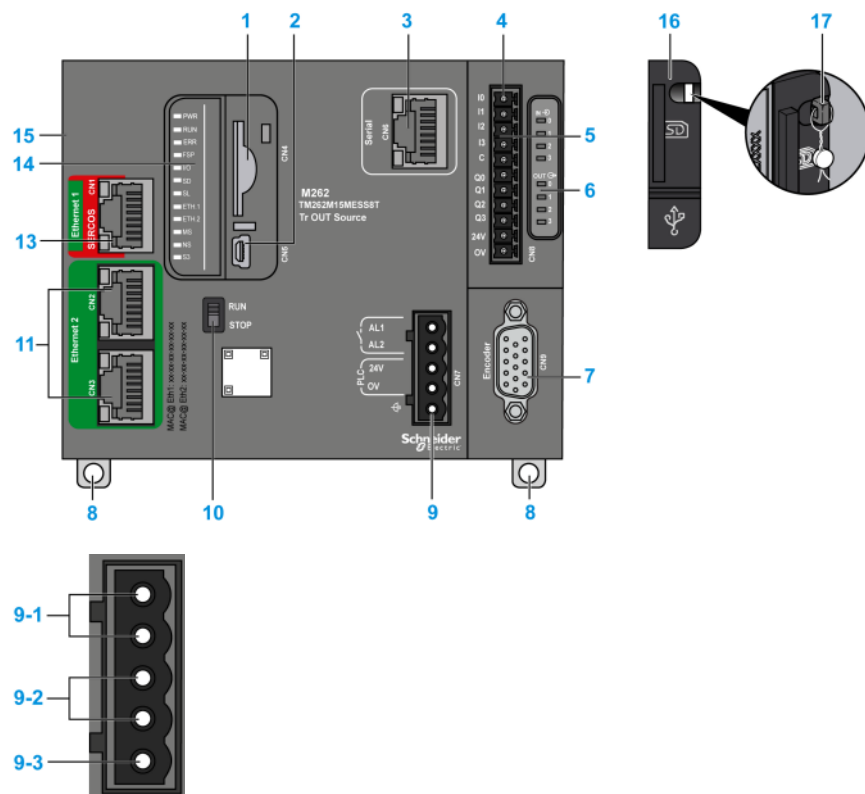

N°	Description	Refer to
1	SD card slot	SD Card, page 36
2	USB mini-B programming port (for terminal connection to a programming PC)	USB Mini-B Programming Port, page 119
3	Serial line port (type RJ45 (RS-232 or RS-485))	Serial Line, page 121
4	Inputs/outputs terminal connector	Embedded Digital Inputs, page 103
		Embedded Digital Outputs, page 106
5	TM3 bus connector	TM3 Expansion Modules, page 20
6	I/O status LEDs	Fast Inputs Status LEDs, page 105
		Fast Outputs Status LEDs, page 105
7	Encoder connector	Encoder Interface, page 110
8	Clip-on lock for 35 mm (1.38 in.) top hat section rail (DIN rail)	Top Hat Section Rail (DIN rail), page 49
9-1	Alarm relay terminal connector	Alarm Relay, page 40
9-2	24 Vdc power supply	DC Power supply Characteristics and Wiring, page 58
9-3	Functional Earth (FE) grounding connection	Grounding the M262 Logic/Motion Controller, page 60
10	Run/Stop switch	Run/Stop, page 35
11	Dual port Ethernet switch	Ethernet 2 Port, page 117
13	Ethernet 1 / Sercos port	Ethernet 1 Port, page 115
14	Status LEDs	See below
15	TMS bus connector	TMS Expansion Modules (see Modicon M262 Logic/Motion Controller, Programming Guide)
16	Protective cover (for SD card slot and USB mini-B programming port)	-
17	Locking hook (optional lock not included)	-

Status LEDs

This figure shows the status LEDs:

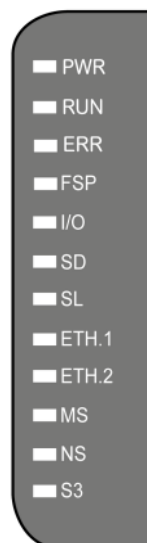

The following table describes the system status LEDs:

Label	Function Type	Color	Status	Description
PWR	Power	Green/Red	Green OFF/Red OFF	Indicates that power is removed.
			Green ON/Red OFF	Indicates that power is applied, normal operation.
			Green ON/Red 1 flash	Elevated internal operating temperature detected (over 80 °C (176 °F)). Take appropriate measures to reduce the temperature.
			Green ON/Red 2 flashes	Detected error on TM3 power.
			Green ON/Red 3 flashes	Detected error on TMS power.
			Green ON/Red 4 flashes	Detected error on Serial line power.
RUN	Machine status	Green	ON	Indicates that the controller is running a valid application.
			Regular flash	Indicates that the controller is running a valid application that is stopped.
			Single flash	Indicates that the controller is running a valid application that is stopped at a breakpoint.
			OFF	Indicates that the controller does not contain a valid application.
ERR	Internal Error	Red	ON	Indicates that an operating system error has been detected. The RUN LED is flashing to indicate that the application is stopped.
			Fast flash	Indicates that the controller has detected a firmware or hardware error.
			Regular flash	Indicates either that a minor error has been detected if RUN is ON or flashing, or that no application has been detected if RUN is OFF.
FSP	Forced stop	Red	ON	Indicates that the Run/Stop switch or Run/stop input has been activated to force the controller to the STOPPED state.
			Regular flash	Indicates that at least one application variable is being forced.
I/O	I/O error	Red	ON	Indicates that I/O or expansion module errors have been detected. More details on the error detected are provided by: <ul style="list-style-type: none"> The system variables <i>i_lwSystemFault_1</i> and <i>i_lwSystemFault_2</i> (see Modicon M262 Logic/Motion Controller, System Functions and Variables, System Library Guide) The Diagnostics > Controller submenu of the Web Server (see Modicon M262 Logic/Motion Controller, Programming Guide)
SD	SD card access	Green	ON	Indicates that a firmware update is completed.
		Green	Regular flash	Indicates that a firmware update or script execution is in progress.
		Yellow	ON	Indicates that a firmware update or script execution is unsuccessful. <p>NOTE: If the script file is not executed, a log file is generated. The log file location in the controller is <i>/usr/Syslog/FWLog.txt</i>.</p>
		Yellow	Regular flash	Indicates that the SD card is being accessed (script execution in progress).
		-	OFF	No SD card activity.
SL	Serial line	Yellow	Flashing	Indicates communication on the serial line.
			OFF	Indicates no serial communication.

Label	Function Type	Color	Status	Description
ETH.1 ETH.2	Ethernet port status	Green	ON	Indicates that the Ethernet port is connected and the IP address is defined.
			3 flashes	Indicates that the Ethernet port is not connected.
			4 flashes	Address conflict detected. Indicates that the configured IP address is already in use.
			5 flashes	Indicates that the address is the default address. The module is waiting for a BOOTP or DHCP sequence.
			6 flashes	Indicates that the configured IP address is not valid. The default IP address is being used.
			OFF	Indicates that the Ethernet port is not configured.
MS	EtherNet/IP controller interface status	Red	ON	Indicates that an unrecoverable error has been detected.
			Regular flash	Indicates that a recoverable error has been detected.
		Green	ON	Indicates that the controller interface is functioning normally.
			Regular flash	Indicates that the configuration is missing, incomplete, incorrect or unused.
		Red/Green	Regular flash	Indicates that an error has been detected.
-	OFF	Indicates that the controller is powered off.		
NS	EtherNet/IP network status	Red	ON	Indicates that one or more connections timed out, or that an error is preventing network communications (duplicate IP address, or bus powered off).
			Regular flash	Indicates that a recoverable error has been detected, for example, one or more connections timed out.
		Green	ON	Indicates that the controller interface is functioning normally and network connections are established.
			Regular flash	Indicates that the controller interface is operating normally, but network connections have not been established, or the network configuration is missing, incomplete, or incorrect.
		Red/Green	Regular flash	Indicates that an error has been detected.
		-	OFF	Indicates that the controller is powered off, or is powered on with no IP address configured.
S3	Sercos 3 master status	-	OFF	No Sercos 3 communication.
		Orange	ON	Sercos 3 initialization (phase-up) in progress.
		Green	ON	Sercos 3 operational.
		Red	ON	Sercos 3 error.

This timing diagram shows the difference between the fast flash, regular flash and single flash:

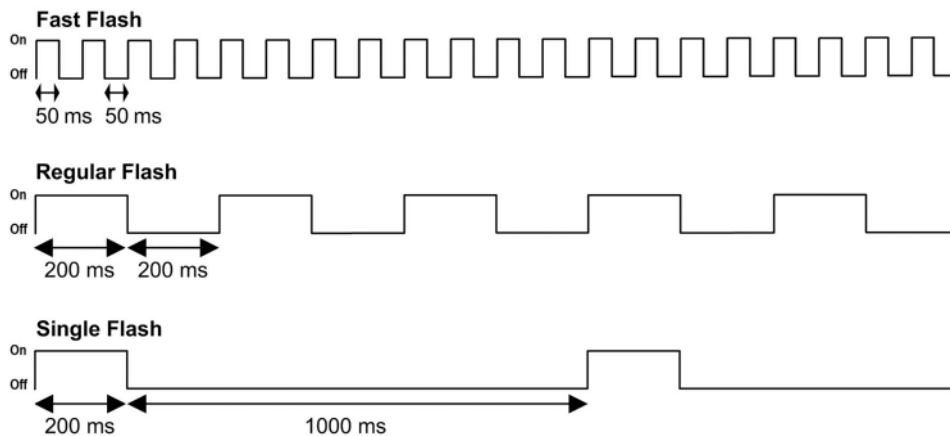

Dimensions

The following figure shows the external dimensions of the TM262M15MESS8T motion controller:

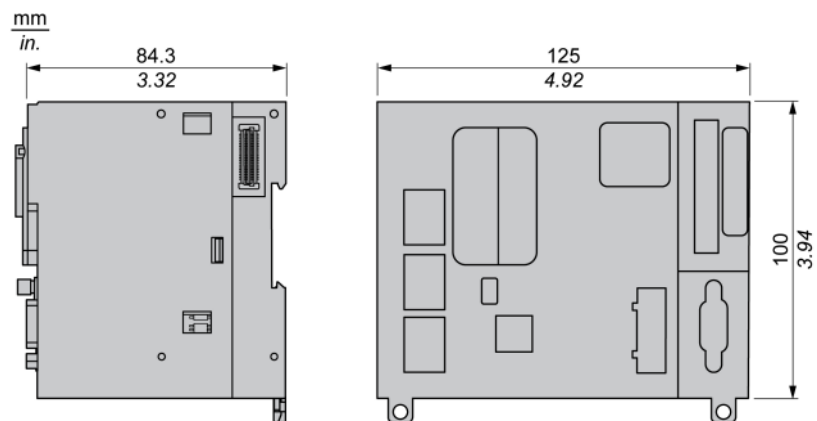

Weight

670 g

TM262M25MESS8T Presentation

Overview

The TM262M25MESS8T motion controller has:

- 4 fast digital inputs
- 4 fast digital outputs (source)
- Communication ports:
 - 1 serial line port
 - 1 USB mini-B programming port
 - 2 Ethernet switched ports
 - 1 Ethernet port for fieldbus with Sercos interface
- Encoder interface (SSI/incremental)

Description

The following figure shows the different components of the TM262M25MESS8T motion controller:

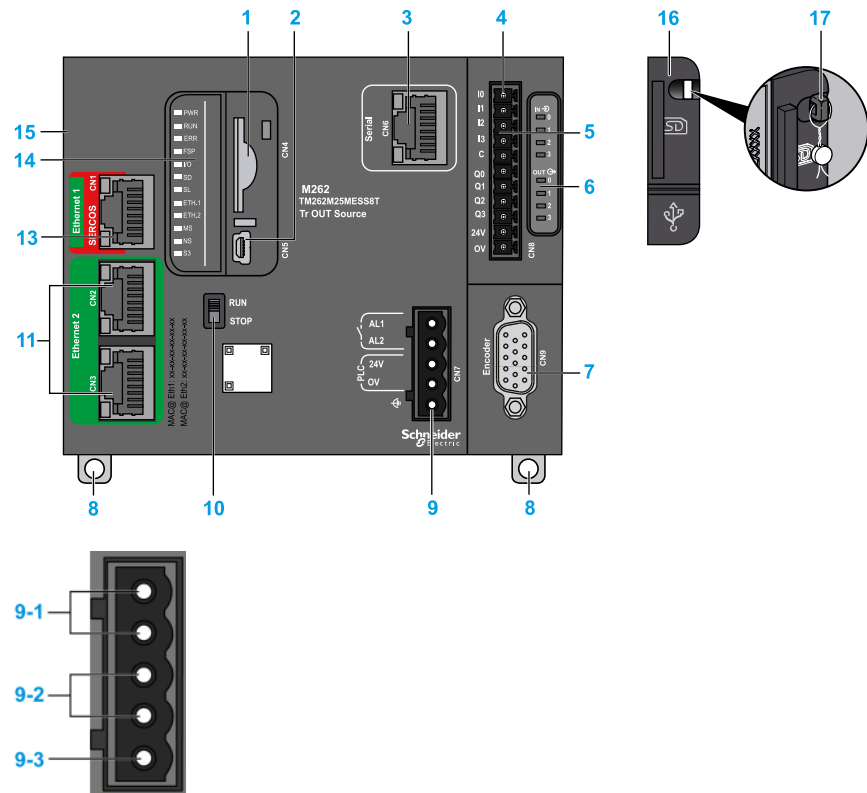

N°	Description	Refer to
1	SD card slot	SD Card, page 36
2	USB mini-B programming port (for terminal connection to a programming PC)	USB Mini-B Programming Port, page 119
3	Serial line port (type RJ45 (RS-232 or RS-485))	Serial Line, page 121
4	Inputs/outputs terminal connector	Embedded Digital Inputs, page 103
		Embedded Digital Outputs, page 106
5	TM3 bus connector	TM3 Expansion Modules, page 20
6	I/O status LEDs	Fast Inputs Status LEDs, page 105
		Fast Outputs Status LEDs, page 105
7	Encoder connector	Encoder Interface, page 110
8	Clip-on lock for 35 mm (1.38 in.) top hat section rail (DIN rail)	Top Hat Section Rail (DIN rail), page 49
9-1	Alarm relay terminal connector	Alarm Relay, page 40
9-2	24 Vdc power supply	DC Power supply Characteristics and Wiring, page 58
9-3	Functional Earth (FE) grounding connection	Grounding the M262 Logic/Motion Controller, page 60
10	Run/Stop switch	Run/Stop, page 35
11	Dual port Ethernet switch	Ethernet 2 Port, page 117
13	Ethernet 1 / Sercos port	Ethernet 1 Port, page 115
14	Status LEDs	See below
15	TMS bus connector	TMS Expansion Modules (see Modicon M262 Logic/Motion Controller, Programming Guide)
16	Protective cover (for SD card slot and USB mini-B programming port)	-
17	Locking hook (optional lock not included)	-

Status LEDs

This figure shows the status LEDs:

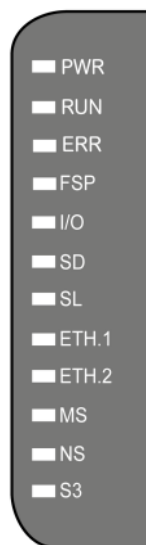

The following table describes the system status LEDs:

Label	Function Type	Color	Status	Description
PWR	Power	Green/Red	Green OFF/Red OFF	Indicates that power is removed.
			Green ON/Red OFF	Indicates that power is applied, normal operation.
			Green ON/Red 1 flash	Elevated internal operating temperature detected (over 80 °C (176 °F)). Take appropriate measures to reduce the temperature.
			Green ON/Red 2 flashes	Detected error on TM3 power.
			Green ON/Red 3 flashes	Detected error on TMS power.
			Green ON/Red 4 flashes	Detected error on Serial line power.
RUN	Machine status	Green	ON	Indicates that the controller is running a valid application.
			Regular flash	Indicates that the controller is running a valid application that is stopped.
			Single flash	Indicates that the controller is running a valid application that is stopped at a breakpoint.
			OFF	Indicates that the controller does not contain a valid application.
ERR	Internal Error	Red	ON	Indicates that an operating system error has been detected. The RUN LED is flashing to indicate that the application is stopped.
			Fast flash	Indicates that the controller has detected a firmware or hardware error.
			Regular flash	Indicates either that a minor error has been detected if RUN is ON or flashing, or that no application has been detected if RUN is OFF.
FSP	Forced stop	Red	ON	Indicates that the Run/Stop switch or Run/stop input has been activated to force the controller to the STOPPED state.
			Regular flash	Indicates that at least one application variable is being forced.
I/O	I/O error	Red	ON	Indicates that I/O or expansion module errors have been detected. More details on the error detected are provided by: <ul style="list-style-type: none"> The system variables <i>i_!wSystemFault_1</i> and <i>i_!wSystemFault_2</i> (see Modicon M262 Logic/Motion Controller, System Functions and Variables, System Library Guide) The Diagnostics > Controller submenu of the Web Server (see Modicon M262 Logic/Motion Controller, Programming Guide)
SD	SD card access	Green	ON	Indicates that a firmware update is completed.
		Green	Regular flash	Indicates that a firmware update or script execution is in progress.
		Yellow	ON	Indicates that a firmware update or script execution is unsuccessful. NOTE: If the script file is not executed, a log file is generated. The log file location in the controller is <i>/usr/Syslog/FWLog.txt</i> .
		Yellow	Regular flash	Indicates that the SD card is being accessed (script execution in progress).
		-	OFF	No SD card activity.
SL	Serial line	Yellow	Flashing	Indicates communication on the serial line.
			OFF	Indicates no serial communication.

Label	Function Type	Color	Status	Description
ETH.1 ETH.2	Ethernet port status	Green	ON	Indicates that the Ethernet port is connected and the IP address is defined.
			3 flashes	Indicates that the Ethernet port is not connected.
			4 flashes	Address conflict detected. Indicates that the configured IP address is already in use.
			5 flashes	Indicates that the address is the default address. The module is waiting for a BOOTP or DHCP sequence.
			6 flashes	Indicates that the configured IP address is not valid. The default IP address is being used.
			OFF	Indicates that the Ethernet port is not configured.
MS	EtherNet/IP controller interface status	Red	ON	Indicates that an unrecoverable error has been detected.
			Regular flash	Indicates that a recoverable error has been detected.
		Green	ON	Indicates that the controller interface is functioning normally.
			Regular flash	Indicates that the configuration is missing, incomplete, incorrect or unused.
		Red/Green	Regular flash	Indicates that an error has been detected.
-	OFF	Indicates that the controller is powered off.		
NS	EtherNet/IP network status	Red	ON	Indicates that one or more connections timed out, or that an error is preventing network communications (duplicate IP address, or bus powered off).
			Regular flash	Indicates that a recoverable error has been detected, for example, one or more connections timed out.
		Green	ON	Indicates that the controller interface is functioning normally and network connections are established.
			Regular flash	Indicates that the controller interface is operating normally, but network connections have not been established, or the network configuration is missing, incomplete, or incorrect.
		Red/Green	Regular flash	Indicates that an error has been detected.
		-	OFF	Indicates that the controller is powered off, or is powered on with no IP address configured.
S3	Sercos 3 master status	-	OFF	No Sercos 3 communication.
		Orange	ON	Sercos 3 initialization (phase-up) in progress.
		Green	ON	Sercos 3 operational.
		Red	ON	Sercos 3 error.

This timing diagram shows the difference between the fast flash, regular flash and single flash:

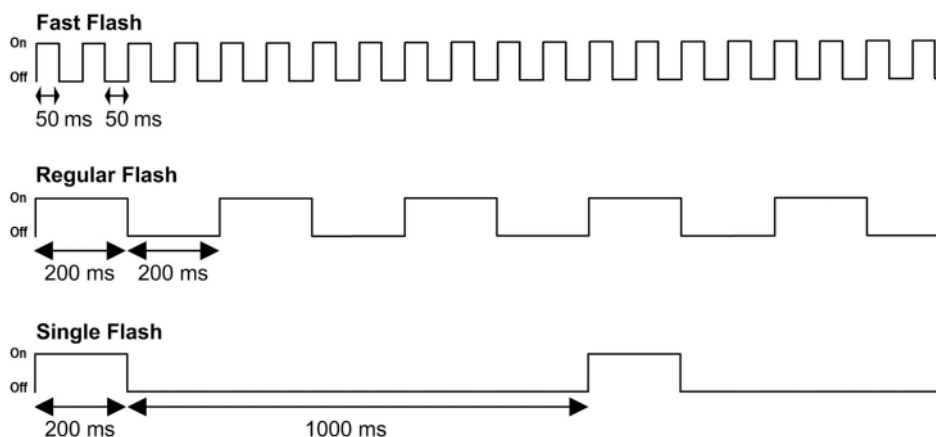

Dimensions

The following figure shows the external dimensions of the TM262M25MESS8T motion controller:

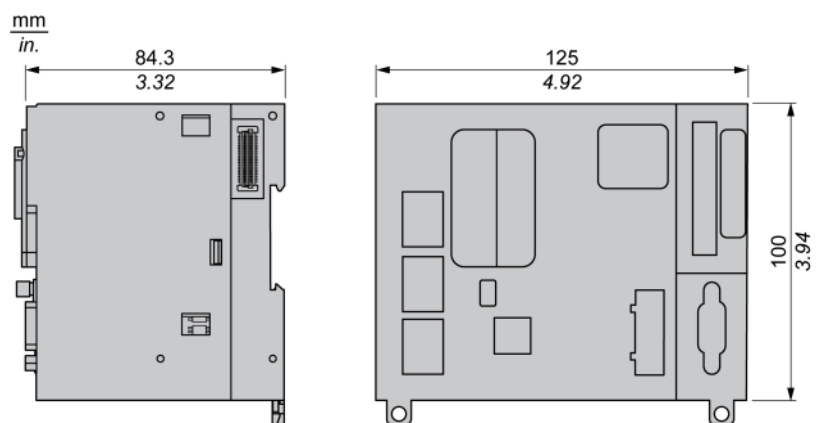

Weight

670 g

TM262M35MESS8T Presentation

Overview

The TM262M35MESS8T motion controller has:

- 4 fast digital inputs
- 4 fast digital outputs (source)
- Communication ports:
 - 1 serial line port
 - 1 USB mini-B programming port
 - 2 Ethernet switched ports
 - 1 Ethernet port for fieldbus with Sercos interface
- Encoder interface (SSI/incremental)

Description

The following figure shows the different components of the TM262M35MESS8T motion controller:

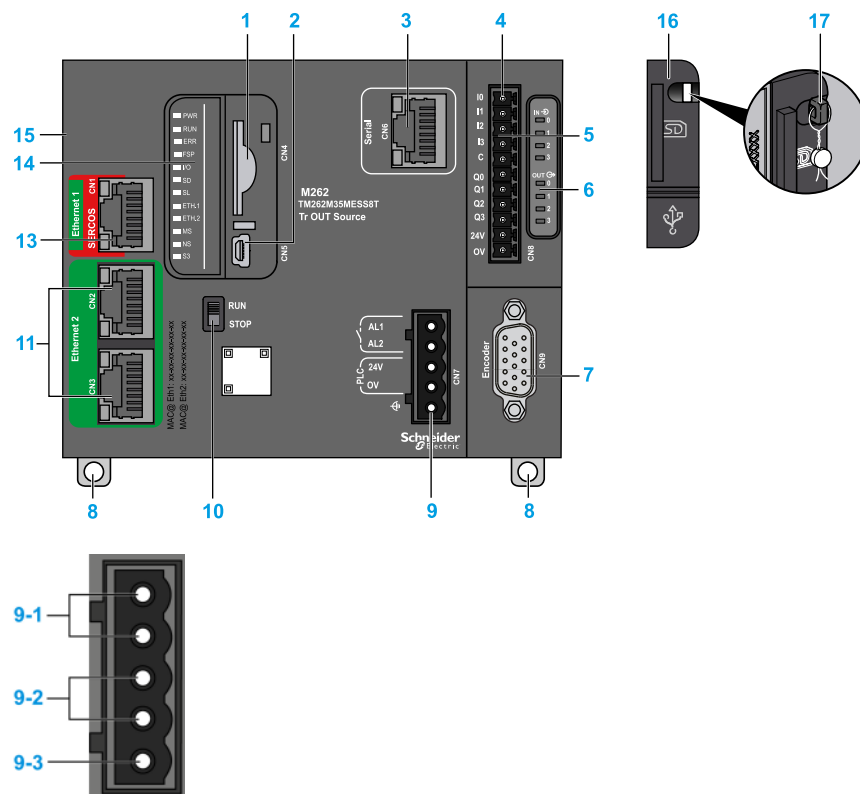

N°	Description	Refer to
1	SD card slot	SD Card, page 36
2	USB mini-B programming port (for terminal connection to a programming PC)	USB Mini-B Programming Port, page 119
3	Serial line port (type RJ45 (RS-232 or RS-485))	Serial Line, page 121
4	Inputs/outputs terminal connector	Embedded Digital Inputs, page 103
		Embedded Digital Outputs, page 106
5	TM3 bus connector	TM3 Expansion Modules, page 20
6	I/O status LEDs	Fast Inputs Status LEDs, page 105
		Fast Outputs Status LEDs, page 105
7	Encoder connector	Encoder Interface, page 110
8	Clip-on lock for 35 mm (1.38 in.) top hat section rail (DIN rail)	Top Hat Section Rail (DIN rail), page 49
9-1	Alarm relay terminal connector	Alarm Relay, page 40
9-2	24 Vdc power supply	DC Power supply Characteristics and Wiring, page 58
9-3	Functional Earth (FE) grounding connection	Grounding the M262 Logic/Motion Controller, page 60
10	Run/Stop switch	Run/Stop, page 35
11	Dual port Ethernet switch	Ethernet 2 Port, page 117
13	Ethernet 1 / Sercos port	Ethernet 1 Port, page 115
14	Status LEDs	See below
15	TMS bus connector	TMS Expansion Modules (see Modicon M262 Logic/Motion Controller, Programming Guide)
16	Protective cover (for SD card slot and USB mini-B programming port)	-
17	Locking hook (optional lock not included)	-

Status LEDs

This figure shows the status LEDs:

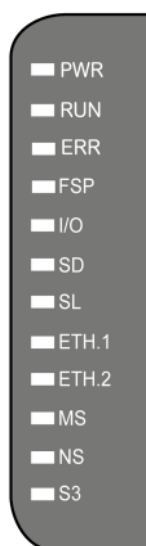

The following table describes the system status LEDs:

Label	Function Type	Color	Status	Description
PWR	Power	Green/Red	Green OFF/Red OFF	Indicates that power is removed.
			Green ON/Red OFF	Indicates that power is applied, normal operation.
			Green ON/Red 1 flash	Elevated internal operating temperature detected (over 80 °C (176 °F)). Take appropriate measures to reduce the temperature.
			Green ON/Red 2 flashes	Detected error on TM3 power.
			Green ON/Red 3 flashes	Detected error on TMS power.
			Green ON/Red 4 flashes	Detected error on Serial line power.
RUN	Machine status	Green	ON	Indicates that the controller is running a valid application.
			Regular flash	Indicates that the controller is running a valid application that is stopped.
			Single flash	Indicates that the controller is running a valid application that is stopped at a breakpoint.
			OFF	Indicates that the controller does not contain a valid application.
ERR	Internal Error	Red	ON	Indicates that an operating system error has been detected. The RUN LED is flashing to indicate that the application is stopped.
			Fast flash	Indicates that the controller has detected a firmware or hardware error.
			Regular flash	Indicates either that a minor error has been detected if RUN is ON or flashing, or that no application has been detected if RUN is OFF.
FSP	Forced stop	Red	ON	Indicates that the Run/Stop switch or Run/stop input has been activated to force the controller to the STOPPED state.
			Regular flash	Indicates that at least one application variable is being forced.
I/O	I/O error	Red	ON	Indicates that I/O or expansion module errors have been detected. More details on the error detected are provided by: <ul style="list-style-type: none"> The system variables <i>i_lwSystemFault_1</i> and <i>i_lwSystemFault_2</i> (see Modicon M262 Logic/Motion Controller, System Functions and Variables, System Library Guide) The Diagnostics > Controller submenu of the Web Server (see Modicon M262 Logic/Motion Controller, Programming Guide)
SD	SD card access	Green	ON	Indicates that a firmware update is completed.
		Green	Regular flash	Indicates that a firmware update or script execution is in progress.
		Yellow	ON	Indicates that a firmware update or script execution is unsuccessful. <p>NOTE: If the script file is not executed, a log file is generated. The log file location in the controller is <i>/usr/Syslog/FWLog.txt</i>.</p>
		Yellow	Regular flash	Indicates that the SD card is being accessed (script execution in progress).
		-	OFF	No SD card activity.
SL	Serial line	Yellow	Flashing	Indicates communication on the serial line.
			OFF	Indicates no serial communication.

Label	Function Type	Color	Status	Description
ETH.1 ETH.2	Ethernet port status	Green	ON	Indicates that the Ethernet port is connected and the IP address is defined.
			3 flashes	Indicates that the Ethernet port is not connected.
			4 flashes	Address conflict detected. Indicates that the configured IP address is already in use.
			5 flashes	Indicates that the address is the default address. The module is waiting for a BOOTP or DHCP sequence.
			6 flashes	Indicates that the configured IP address is not valid. The default IP address is being used.
			OFF	Indicates that the Ethernet port is not configured.
MS	EtherNet/IP controller interface status	Red	ON	Indicates that an unrecoverable error has been detected.
			Regular flash	Indicates that a recoverable error has been detected.
		Green	ON	Indicates that the controller interface is functioning normally.
			Regular flash	Indicates that the configuration is missing, incomplete, incorrect or unused.
		Red/Green	Regular flash	Indicates that an error has been detected.
-	OFF	Indicates that the controller is powered off.		
NS	EtherNet/IP network status	Red	ON	Indicates that one or more connections timed out, or that an error is preventing network communications (duplicate IP address, or bus powered off).
			Regular flash	Indicates that a recoverable error has been detected, for example, one or more connections timed out.
		Green	ON	Indicates that the controller interface is functioning normally and network connections are established.
			Regular flash	Indicates that the controller interface is operating normally, but network connections have not been established, or the network configuration is missing, incomplete, or incorrect.
		Red/Green	Regular flash	Indicates that an error has been detected.
		-	OFF	Indicates that the controller is powered off, or is powered on with no IP address configured.
S3	Sercos 3 master status	-	OFF	No Sercos 3 communication.
		Orange	ON	Sercos 3 initialization (phase-up) in progress.
		Green	ON	Sercos 3 operational.
		Red	ON	Sercos 3 error.

This timing diagram shows the difference between the fast flash, regular flash and single flash:

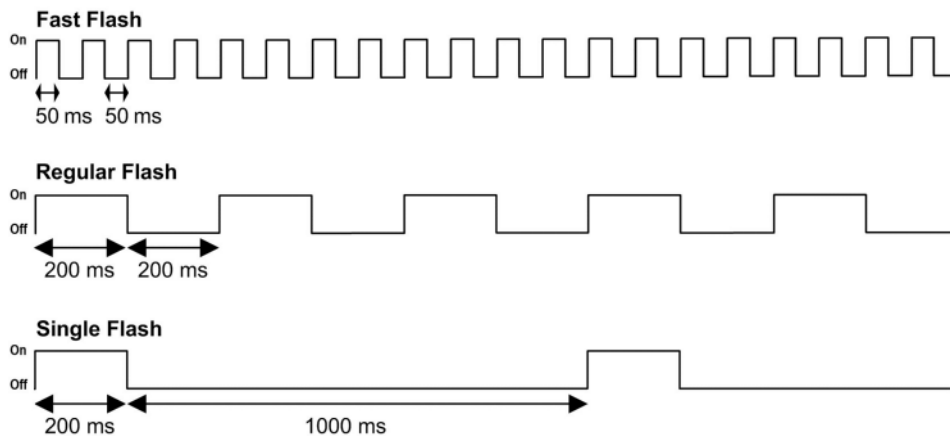

Dimensions

The following figure shows the external dimensions of the TM262M35MESS8T motion controller:

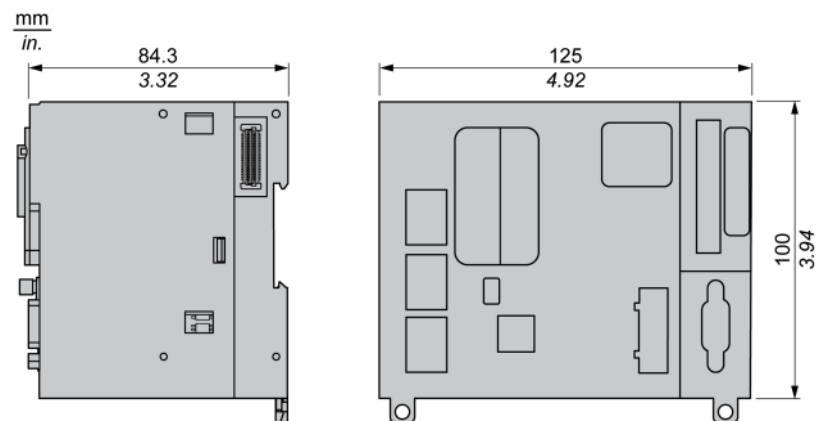

Weight

670 g

Embedded I/O Channels

Overview

This chapter describes the embedded I/O channels.

Digital Inputs

Overview

The Modicon M262 Logic/Motion Controller has 4 embedded fast digital inputs.

The digital inputs are connected on the front face of the controller.

⚠ DANGER

FIRE HAZARD

Use only the correct wire sizes for the maximum current capacity of the I/O channels and power supplies.

Failure to follow these instructions will result in death or serious injury.

⚠ WARNING

UNINTENDED EQUIPMENT OPERATION

Do not exceed any of the rated values specified in the environmental and electrical characteristics tables.

Failure to follow these instructions can result in death, serious injury, or equipment damage.

Digital Input Characteristics

This table presents the characteristics of the digital inputs:

Characteristic		Value
Number of input channels		4 (I0...I3)
Input type		IEC61131-2 Type 1
Logic type		Sink
Rated power supply voltage		24 Vdc
Voltage limit		30 Vdc
Rated input current		7.5 mA
Input impedance		2.81 kΩ
Input limit values	Voltage at state 1	> 15 Vdc (15...30 Vdc)
	Voltage at state 0	< 5 Vdc (0...5 Vdc)
	Current at state 1	> 3 mA
	Current at state 0	< 1.5 mA
Input delay	Turn on time	< 1 μs + filter delay
	Turn off time	< 1 μs + filter delay
Isolation	Between input channels	No
	Between input and internal logic	550 Vac for 1 min.
	Between input and output	550 Vac for 1 min.
Cable	Type	Shielded cable, including COM signal
	Length	10 m (32.8 ft) max.
Connection type		Removable spring terminal block
Connector insertion/removal durability		Over 100 times

Pin Assignment

The digital inputs are connected on the front face of the controller.

This illustration describes the pin assignment of the connector:

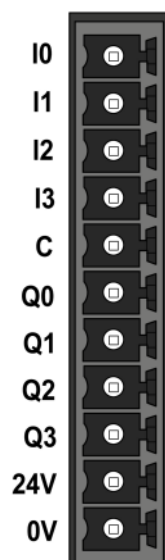

This table describes the pin assignment of the embedded I/O connector:

Pin	Label	Description
1	I0	Digital input 0
2	I1	Digital input 1
3	I2	Digital input 2
4	I3	Digital input 3
5	C	Inputs common port

Status LEDs

This figure shows the I/O status LEDs:



LED	Color	Status	Description
0...3	Green	On	The corresponding input channel is activated
		Off	The corresponding input channel is deactivated

NOTE: The LEDs indicate the logic state of each input.

Wiring Rules

See *Wiring Best Practices*, page 54.

Electromagnetic perturbations may cause the application to operate in an unexpected manner.

⚠ WARNING
<p>UNINTENDED EQUIPMENT OPERATION</p> <ul style="list-style-type: none"> • Adapt the programmable filtering to the frequency applied at the inputs. • Use shielded cables wherever specified, connected to the functional ground using the grounding bar. • Use a specific 24 Vdc supply for inputs and outputs. <p>Failure to follow these instructions can result in death, serious injury, or equipment damage.</p>

Wiring Diagram

This illustration presents the fast inputs wiring diagram:

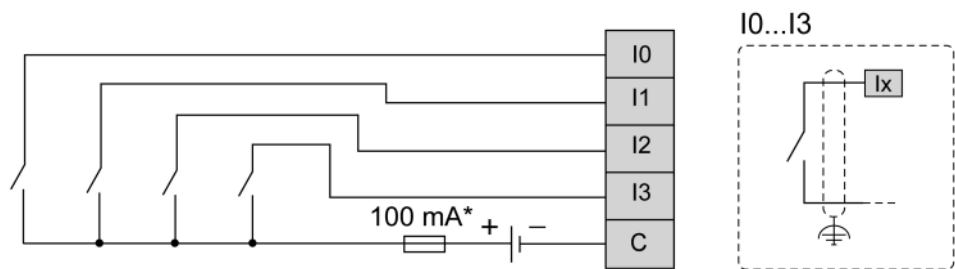

* Type T fuse

Digital Outputs

Overview

The Modicon M262 Logic/Motion Controller has 4 embedded fast digital outputs.

The digital outputs are connected on the front face of the controller.

⚠ DANGER

FIRE HAZARD

Use only the correct wire sizes for the maximum current capacity of the I/O channels and power supplies.

Failure to follow these instructions will result in death or serious injury.

⚠ WARNING

UNINTENDED EQUIPMENT OPERATION

Do not exceed any of the rated values specified in the environmental and electrical characteristics tables.

Failure to follow these instructions can result in death, serious injury, or equipment damage.

Fast Outputs Characteristics

The table below describes the characteristics of the embedded digital outputs:

Characteristic		Value
Number of output channels		4 outputs (Q0...Q3)
Output type		Transistor
Output signal type		Source (push-pull)
Rated output voltage		24 Vdc
Output current		500 mA
Total output current		2 A
Leakage current when switched off		< 0.01 mA
Maximum power of filament lamp		1.5 W max.
Turn on time		1 µs max.
Turn off time		1 µs max.
Protection against short circuit or overload		Yes. Typical current 5 A per output. Defect managed by group: Q0...Q3
Automatic rearming after short circuit or overload		Yes, 10 s (enabled/disabled by the software)
Isolation	Between output channels	No
	Between output and internal logic	550 Vac for 1 minute
	Between output and input	550 Vac for 1 minute
Cable length		< 30 m (98.4 ft)
Connection type		Removable spring terminal block
Connector insertion/removal durability		Over 100 times
<p>NOTE: Refer to <i>Protecting Outputs from Inductive Load Damage</i>, page 56 for additional information concerning output protection.</p>		

Pin Assignment

This illustration describes the pin assignment of the connector:

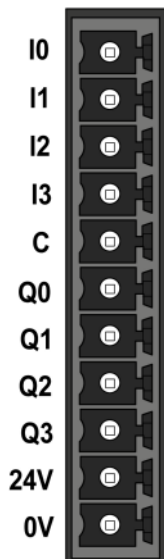

This table describes the pin assignment of the embedded I/O connector:

Pin	Label	Description
6	Q0	Digital output 0
7	Q1	Digital output 1
8	Q2	Digital output 2
9	Q3	Digital output 3
10	24V	Outputs and encoder 24 Vdc power supply
11	0V	Outputs and encoder 0 Vdc power supply

Outputs/Encoder Power Supply Characteristics

This table shows the characteristics of the power supply provided by the controller to the embedded digital outputs and the encoder interface, page 110:

Characteristic	Value
Nominal voltage	24 Vdc
Power supply voltage range	20.4...28.8 Vdc (ripple \pm 10% Un)
Power supply type	PELV
Maximum input current	2.6 A
Inrush current	Not limited
Voltage drop immunity	No
Reverse polarity protection	Yes
Overload protection	No. Non-replaceable 4 A slow fuse
Overvoltage protection	No
Voltage presence detection	Yes, typically >16 V I/O Status Codes (see Modicon M262 Logic/Motion Controller, System Functions and Variables, System Library Guide) diagnostic is available in EcoStruxure Machine Expert software.
Isolation	550 Vac for 1 minute
Cable length	< 3 m (9.84 ft)

Status LEDs

This figure shows the I/O status LEDs:



LED	Color	Status	Description
0...3	Green	On	The corresponding output channel is activated
		Off	The corresponding output channel is deactivated

NOTE: The LEDs indicate the logic state of each output.

Wiring Rules

See Wiring Best Practices, page 54.

Electromagnetic perturbations may cause the application to operate in an unexpected manner.

⚠ WARNING
<p>UNINTENDED EQUIPMENT OPERATION</p> <ul style="list-style-type: none"> Adapt the programmable filtering to the frequency applied at the inputs. Use shielded cables wherever specified, connected to the functional ground using the grounding bar. Use a specific 24 Vdc supply for inputs and outputs. <p>Failure to follow these instructions can result in death, serious injury, or equipment damage.</p>

Fast Outputs Wiring Diagram

This illustration presents the fast outputs wiring diagram:

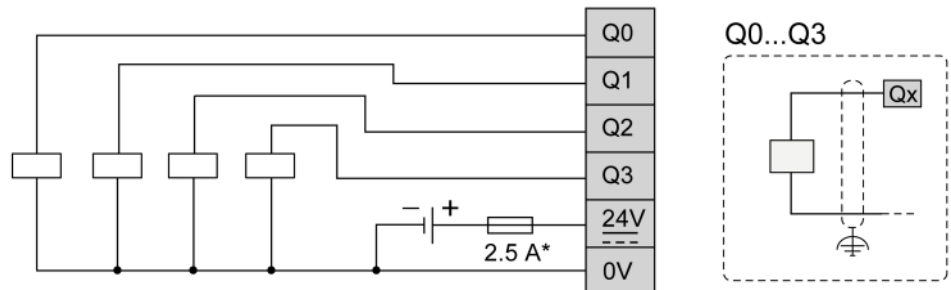

* Use a type T fuse appropriate for the load, not to exceed 2.5 A

⚠ WARNING
<p>UNINTENDED EQUIPMENT OPERATION</p> <p>Ensure that the physical wiring respects the connections indicated in the wiring diagram.</p> <p>Failure to follow these instructions can result in death, serious injury, or equipment damage.</p>

Encoder Interface

Encoder Interface

Overview

The following illustration shows the encoder interface on TM262M• references:

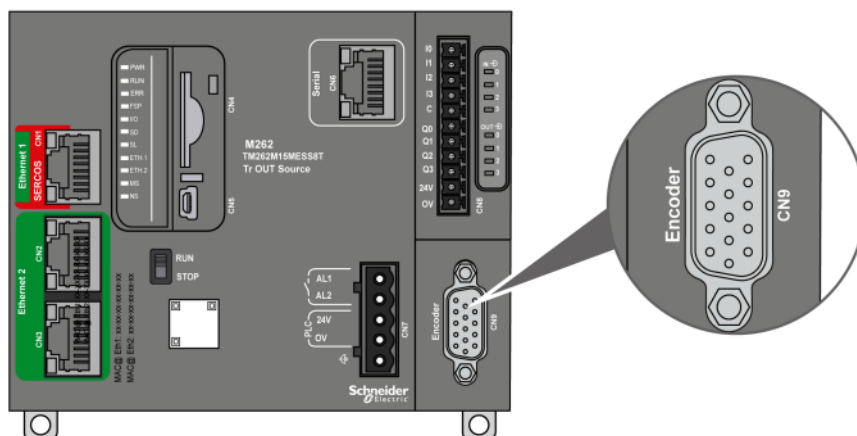

The encoder interface supports the following connection types:

- Incremental (RS422 (5 V) or push-pull (24 V))
- Absolute (SSI)

The advantage of using an Absolute (SSI) encoder for position detection is that the position of the moving object being monitored is retained. On power-up, or restart following a power interruption, the data provided by the encoder can therefore be used without qualification by the controller.

The encoder interface can provide power to the encoder.

The power supply to the encoder interface is provided by the controller through the embedded digital outputs, page 106 power supply.

NOTE: You must take into account the consumption of the encoder when sizing the power supply for the embedded digital outputs.

Characteristics

The table below shows the characteristics of the encoder:

Characteristics	Description	
Inputs	Rated input voltage	5 Vdc
	Input voltage limits	28.8 Vdc
	Rated input current	1.5 mA at 5 V 8 mA at 24 V
	Input impedance	2.85 kΩ
Incremental Encoder	Type of signal	A+, A-, B+, B-, Z+, Z-
	Maximum operating frequency	200 kHz
	Number of bits	32, with configurable frame: <ul style="list-style-type: none"> • Number of turns • Number of bits/turn • Binary or gray format • Parity
SSI Encoder	Clock frequency	100 KHz, 250 KHz, or 500 KHz (selectable in the software)
	Clock voltage	5 Vdc
Power supply to encoder (selectable in the software)	None, 5 Vdc, or 24 Vdc:	
	None	No power is supplied to the encoder.
	5 Vdc	Nominal voltage: 5.1 Vdc ± 5 % Maximum current: 200 mA Overcurrent and short circuit protection: No Encoder power return: Yes (selectable in the software). Typical threshold: 2 V
	24 Vdc	Use a regulated and smoothed power supply on the 24 Vdc power inputs of the CN8 terminal connector, with the specific characteristics of voltage limits and ripple factor specified for the encoder. Nominal voltage: 24 Vdc with -0.7 Vdc typical internal voltage drop Maximum current: 200 mA Overcurrent and short circuit protection: Yes. Maximum current < 1.5 A Encoder power return: Yes (selectable in the software). Typical threshold: 9 V
Isolation	Between encoder signals and internal logic	550 Vac for 1 min.
Connector	Type	Removable 15-pin Sub-D HD
	Insertion/removal durability	> 100 times
Cable	Type	Twisted pairs, shielded
	Length	≤ 250 kHz: 100 m (328 ft) maximum. See Note below. 500 kHz: 50 m (164 ft) maximum. See Note below.

NOTE: Calculation of Maximum Cable Length

Maximum cable length [m] = Maximum voltage drop for the cable [V] x Wire cross section [mm²] / (Encoder current [A] x 0.0171 [Ω.mm²/m])

where:

Maximum voltage drop for the cable = (Minimum module output voltage - Minimum encoder input voltage) / 2

Example:

Encoder consumes 100 mA with a 4.5...5.5 V supply

Minimum module output voltage = 5.1 Vdc x 0.95 = 4.845 Vdc

Maximum voltage drop for the cable = (4.845 Vdc - 4.5 Vdc) / 2 = 0.1725 Vdc

Maximum cable length 0.14 mm² = 0.1725 x 0.14 / (0.1 x 0.0171) = 14 m

Maximum cable length 0.50 mm² = 0.1725 x 0.50 / (0.1 x 0.0171) = 50 m

Pin Assignment

The encoder interface consists of a 15-pin Sub-D HD connector.

The following illustration describes the pins numbering:

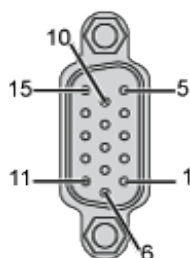

The following table describes the pins of the encoder:

Description	Encoder	Pin	Wire colors
Incremental encoder	A+	1	Red/white
	A-	2	Brown
	Z+	4	Orange
	Z-	5	Yellow
	B+	10	White
	B-	11	Purple
Absolute (SSI) encoder	SSI data +	1	Red/white
	SSI data -	2	Brown
	CLKSSI +	6	Green
	CLKSSI -	14	Light brown
5 V Encoder supply	+ 5 Vdc	15	Light purple
	0 Vdc	8	Pink
24 V Encoder supply	+ 24 Vdc	7	Blue
	0 Vdc	8	Pink
Encoder power distribution feedback ⁽¹⁾	Supply return	13	Light green
Shielding	-	Shell	Cable braided shield
(1) Detection of encoder supply from controller. Default: Raised if signal is absent.			

Wiring Diagram

The following illustration describes the wiring diagram of an incremental push-pull encoder (24 Vdc power supply to encoder) mounted on the encoder interface:

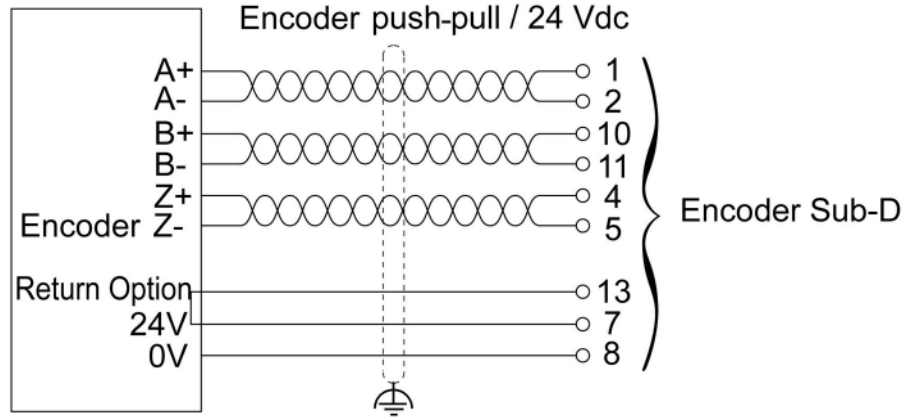

The following illustration describes the wiring diagram of an incremental RS422 encoder (5 Vdc power supply to encoder) mounted on the encoder interface:

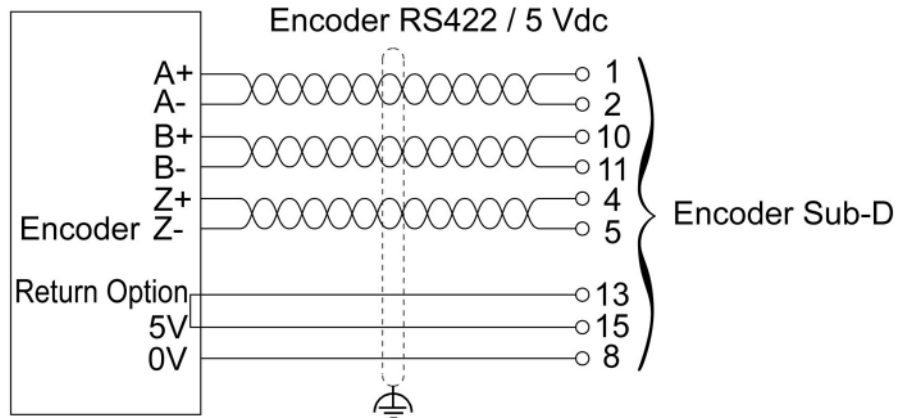

The following illustration describes the wiring diagram of an absolute SSI encoder (24 Vdc power supply to encoder) mounted on the encoder interface:

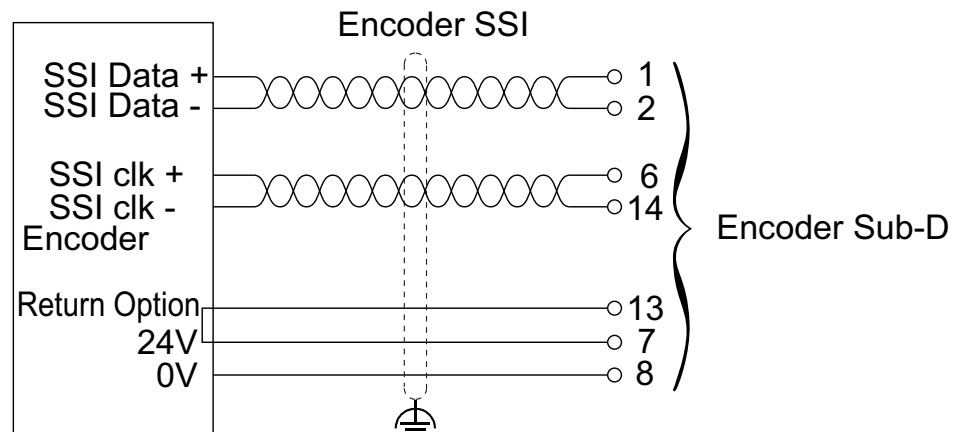

The following illustration describes the wiring diagram of an absolute SSI encoder (5 Vdc power supply to encoder) mounted on the encoder interface:

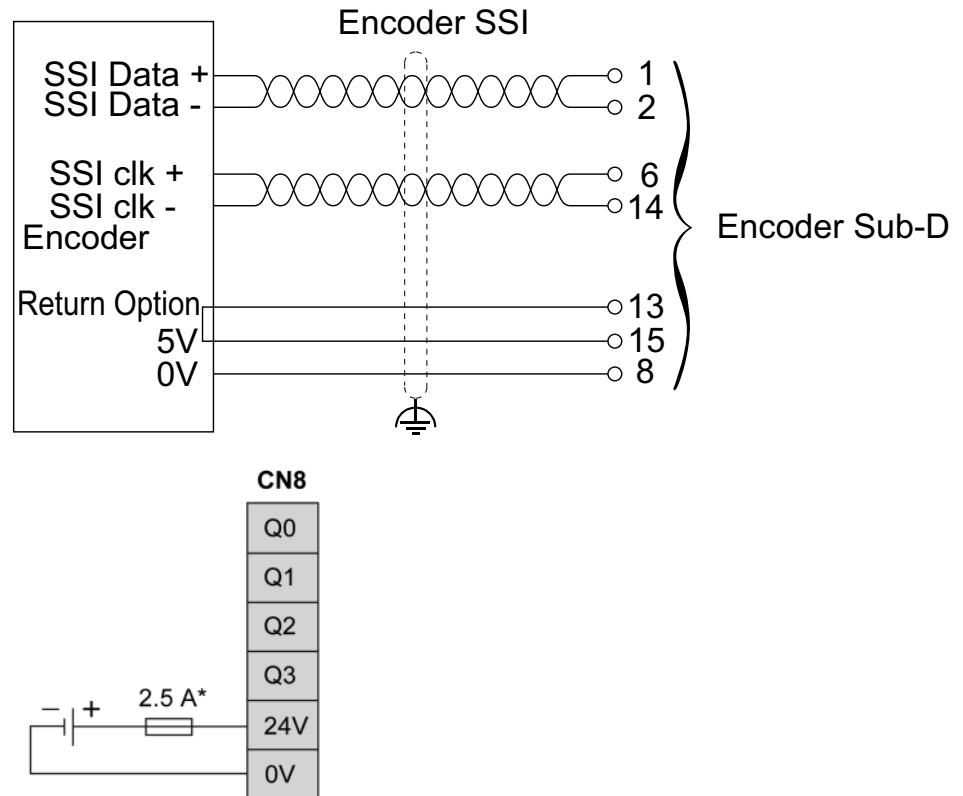

* Use a type T fuse appropriate for the load, not to exceed 2.5 A.

Integrated Communication Ports

Ethernet 1 Port

Overview

The M262 Logic/Motion Controller is equipped with Ethernet communications ports:

Port Name	Number of Ports	Reference
Ethernet 1	1 (100BASE-T)	TM262L•
	1 (100BASE-T / SERCOS)	TM262M•
Ethernet 2	2 (dual 1000BASE-T Ethernet switch)	TM262•

Characteristics

This table describes the physical characteristics of the Ethernet 1 port:

Characteristic	Description
Protocols	Modbus TCP, EtherNet/IP, SERCOS III (on TM262M• references)
Connector type	RJ45
Auto negotiation	From 10 Mbps half duplex to 100 Mbps full duplex
Cable type	Shielded
Automatic cross-over detection	MDI/MDIX

Ethernet 1 Pin Assignment

This figure shows the Ethernet 1 connector pin assignment:

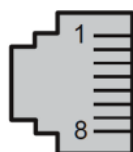

This table describes the Ethernet 1 RJ45 connector pins:

Pin N°	100BASE-T	Description
1	TD+	Transmit data +
2	TD-	Transmit Data -
3	RD+	Receive Data +
4	-	Reserved
5	-	Reserved
6	RD-	Receive Data -
7	-	Reserved
8	-	Reserved

NOTE: The controller supports the MDI/MDIX auto-crossover cable function. It is not necessary to use special Ethernet crossover cables to connect devices directly to this port (connections without an Ethernet hub or switch).

NOTE: Ethernet cable disconnection is detected every second. In case of disconnection of a short duration (< 1 second), the network status may not indicate the disconnection.

Status LED

This figure shows the RJ45 connector status LEDs:

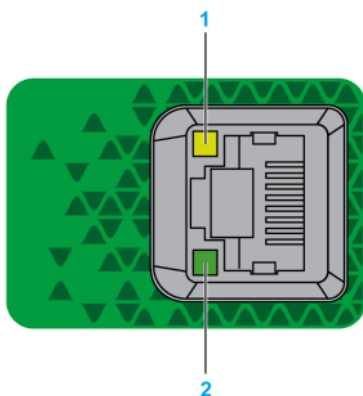

This table describes the Ethernet port status LEDs:

Label	Description	LED		
		Color	Status	Description
1	Ethernet link/speed	Green/Yellow	Off	No link
			Solid yellow	Link at 10 Mbps
			Solid green	Link at 100 Mbps
2	Ethernet activity	Green	Off	No activity and no link
			On	The link is detected, but there is no activity
			Flashing	Transmitting or receiving data

Sercos Port

This illustration presents the location of the Sercos port on TM262M• references:

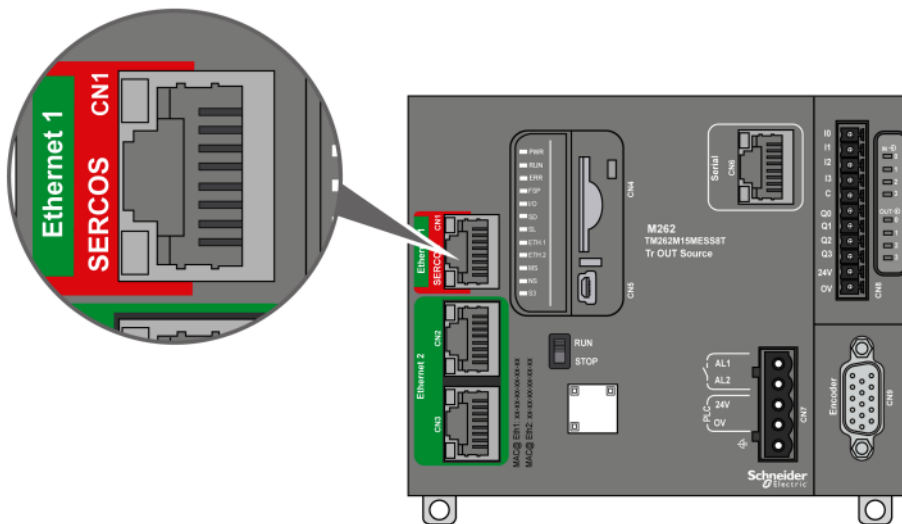

Sercos Port Characteristics

Characteristic	Description
Standard	Sercos III (Master)
Connector type	RJ45
Performances	<ul style="list-style-type: none"> • TM262M05MESS8T: up to 4 axes synchronized at 1 ms • TM262M15MESS8T: up to 4 axes synchronized at 1 ms • TM262M25MESS8T: <ul style="list-style-type: none"> ◦ up to 4 axes synchronized at 1 ms ◦ up to 8 axes synchronized at 2 ms • TM262M35MESS8T: <ul style="list-style-type: none"> ◦ up to 8 axes synchronized at 1 ms ◦ up to 16 axes synchronized at 2 ms ◦ up to 24 axes synchronized at 4ms

Sercos Port Pin Assignment

This illustration presents the pins of the Sercos port:

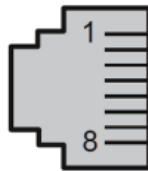

This table describes the pin assignment of the Sercos port:

Pin	Signal	Description
1	TD+	Transmit data +
2	TD-	Transmit data -
3	RD+	Receive data +
4	-	Reserved
5	-	Reserved
6	RD-	Receive data -
7	-	Reserved
8	-	Reserved

Ethernet 2 Ports

Overview

The M262 Logic/Motion Controller is equipped with Ethernet communications ports:

Port Name	Number of Ports	Reference
Ethernet 1	1 (100BASE-T)	TM262L•
	1 (100BASE-T / SERCOS)	TM262M•
Ethernet 2	2 (dual 1000BASE-T Ethernet switch)	TM262•

Characteristics

This table describes the physical characteristics of the Ethernet 2 ports:

Characteristic	Description
Protocols	Modbus TCP, EtherNet/IP, Machine Expert (used for data exchange between a programming PC and the controller, page 123).
Connector type	RJ45
Auto negotiation	From 100 Mbps half duplex to 1000 Mbps full duplex
Cable type	Shielded
Automatic cross-over detection	MDI/MDIX

Ethernet 2 Pin Assignment

This figure shows the Ethernet 2 RJ45 connector pin assignment:

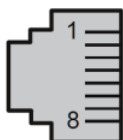

This table describes the Ethernet 2 connector pin assignment:

Pin N°	100BASE-T	1000BASE-T
1	TD+	DA+
2	TD-	DA-
3	RD+	DB+
4	–	DC+
5	–	DC-
6	RD-	DB-
7	–	DD+
8	–	DD-

NOTE: The controller supports the MDI/MDIX auto-crossover cable function. It is not necessary to use special Ethernet crossover cables to connect devices directly to this port (connections without an Ethernet hub or switch).

NOTE: Ethernet cable disconnection is detected every second. In case of disconnection of a short duration (< 1 second), the network status may not indicate the disconnection.

Status LEDs

This figure shows the status LEDs on the RJ45 connector:

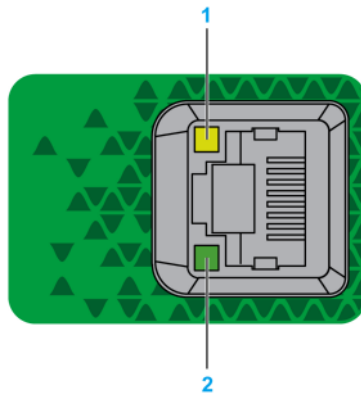

This table describes the Ethernet port status LEDs:

Label	Description	LED		
		Color	Status	Description
1	Ethernet link/speed	Green/Yellow	Off	No link
			Solid yellow	Link at 100 Mbps
			Solid green	Link at 1000 Mbps
2	Ethernet activity	Green	Off	No activity and no link
			On	The link is detected, but there is no activity
			Flashing	Transmitting or receiving data

USB Mini-B Programming Port

Overview

The USB Mini-B Port is the programming port you can use to connect a PC with a USB host port using EcoStruxure Machine Expert software. Using a typical USB cable, this connection is suitable for quick updates of the program or short duration connections to perform maintenance and inspect data values. It is not suitable for long-term connections such as commissioning or monitoring without the use of specially adapted cables to help minimize electromagnetic interference.

⚠ WARNING

UNINTENDED EQUIPMENT OPERATION OR INOPERABLE EQUIPMENT

- You must use a shielded USB cable such as a BMX XCAUSBH0•• secured to the functional ground (FE) of the system for any long-term connection.
- Do not connect more than one controller or bus coupler at a time using USB connections.
- Do not use the USB port(s), if so equipped, unless the location is known to be non-hazardous.

Failure to follow these instructions can result in death, serious injury, or equipment damage.

The following figure shows the location of the USB Mini-B programming port:

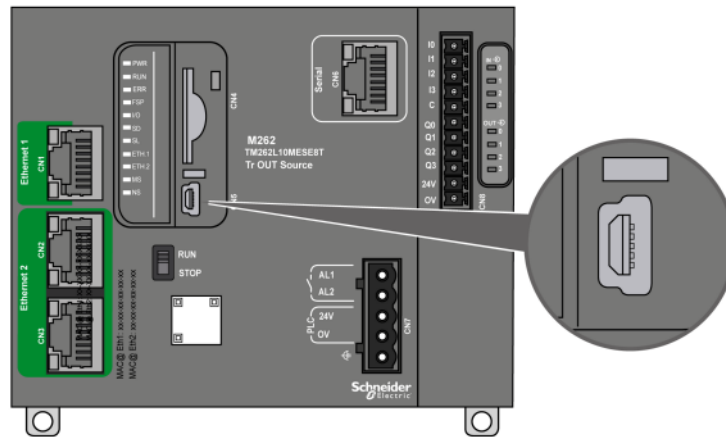

Characteristics

This table describes the characteristics of the USB Mini-B programming port:

Parameter	USB Programming Port
Function	Compatible with USB 2.0
Connector type	Mini-B
Isolation	550 Vac for 1 minute
Cable type	Shielded
Max. Baud Rate	12 Mbits/sec
Max. cable length	5 m (16.5 ft)
Supported protocols	Machine Expert Protocol FTP HTTP Modbus

Serial Line

Overview

The serial line can be used to communicate with devices supporting the Modbus protocol as either master or slave, ASCII protocol (printer, modem...) and Machine Expert Protocol (HMI,...).

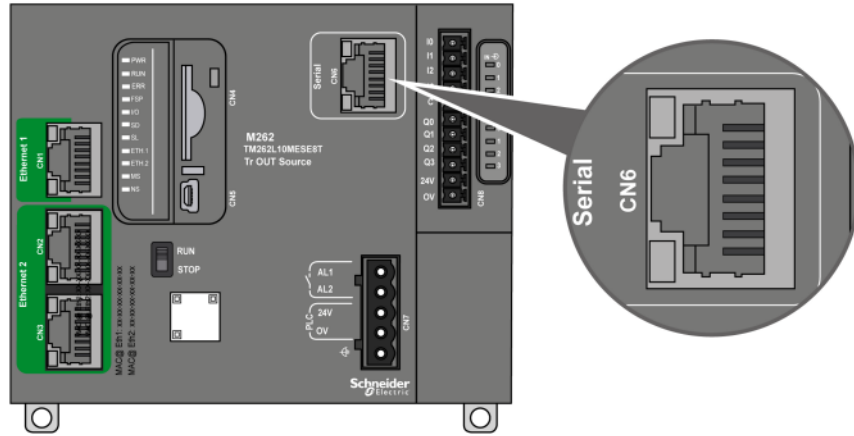

Characteristics

Characteristic		Description
Function		RS485 or RS232 software configured
Connector type		RJ45
Isolation		550 Vac
Baud rate		1200...115200 bps
Cable	Type	Shielded
	Maximum length (between the controller and an isolated junction box)	30 m (98.43 ft) for RS485 15 m (49.21 ft) for RS232
Polarization		Software configuration is used to connect 576 Ω polarization resistors when the node is configured as a master.

NOTE: Some devices provide voltage on RS485 serial connections. Do not connect these voltage lines to your controller as they may damage the controller serial port electronics and render the serial port inoperable.

NOTICE
INOPERABLE EQUIPMENT
Use only the VW3A8306R•• serial cable to connect RS485 devices to your controller.
Failure to follow these instructions can result in equipment damage.

Pin Assignment

The following figure shows the pins of the RJ45 connector:

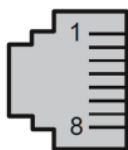

This table describes the pin assignment of the RJ45 connector:

Pin	RS232	RS485
1	RxD	N.C.
2	TxD	N.C.
3	N.C.	N.C.
4	N.C.	D1
5	N.C.	D0
6	N.C.	N.C.
7	N.C.	N.C.
8	Common	Common

N.C.: No connection

⚠ WARNING

UNINTENDED EQUIPMENT OPERATION

Do not connect wires to unused terminals and/or terminals indicated as “No Connection (N.C.)”.

Failure to follow these instructions can result in death, serious injury, or equipment damage.

Status LED

See the description of the **SL** status LED, page 99.

Connecting the M262 Logic/Motion Controller to a PC

Connecting the Controller to a PC

Overview

To transfer, run, and monitor the applications, you can use either a USB cable or an Ethernet connection to connect the controller to a computer with EcoStruxure Machine Expert installed.

NOTICE
<p>INOPERABLE EQUIPMENT</p> <p>Always connect the communication cable to the PC before connecting it to the controller.</p> <p>Failure to follow these instructions can result in equipment damage.</p>

USB Mini-B Port Connection

Cable Reference	Details
BMXXCAUSBH018	Grounded and shielded, this USB cable is suitable for long duration connections.
TCSXCNAMUM3P	This USB cable is suitable for short duration connections such as quick updates or retrieving data values.

NOTE: You can only connect 1 controller or any other device associated with EcoStruxure Machine Expert and its component to the PC at any one time.

The USB Mini-B Port is the programming port you can use to connect a PC with a USB host port using EcoStruxure Machine Expert software. Using a typical USB cable, this connection is suitable for quick updates of the program or short duration connections to perform maintenance and inspect data values. It is not suitable for long-term connections such as commissioning or monitoring without the use of specially adapted cables to help minimize electromagnetic interference.

⚠ WARNING
<p>UNINTENDED EQUIPMENT OPERATION OR INOPERABLE EQUIPMENT</p> <ul style="list-style-type: none"> You must use a shielded USB cable such as a BMX XCAUSBH0•• secured to the functional ground (FE) of the system for any long-term connection. Do not connect more than one controller or bus coupler at a time using USB connections. Do not use the USB port(s), if so equipped, unless the location is known to be non-hazardous. <p>Failure to follow these instructions can result in death, serious injury, or equipment damage.</p>

The communication cable should be connected to the PC first to minimize the possibility of electrostatic discharge affecting the controller.

USB mini-B

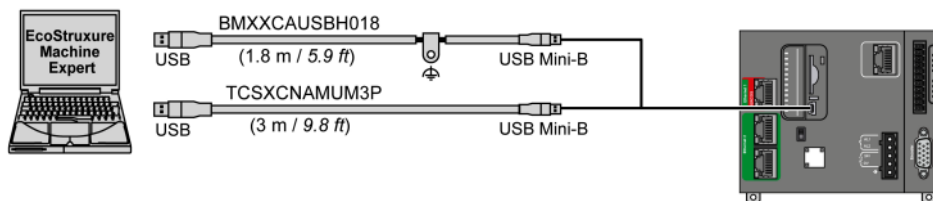

To connect the USB cable to your controller, follow the steps below:

Step	Action
1	<p>1a. If making a long-term connection using the cable BMXXCAUSBH018, or other cable with a ground shield connection, be sure to securely connect the shield connector to the functional ground (FE) or protective ground (PE) of your system before connecting the cable to your controller and your PC.</p> <p>1b. If making a short-term connection using the cable TCSXCNAMUM3P or other non-grounded USB cable, proceed to step 2.</p>
2	Connect your USB cable to the computer.
3	Open the protective cover for the USB mini-B slot on the controller.
4	Connect the mini-B connector of your USB cable to the controller.

Ethernet Port Connection

You can also connect the controller to a PC using an Ethernet cable.

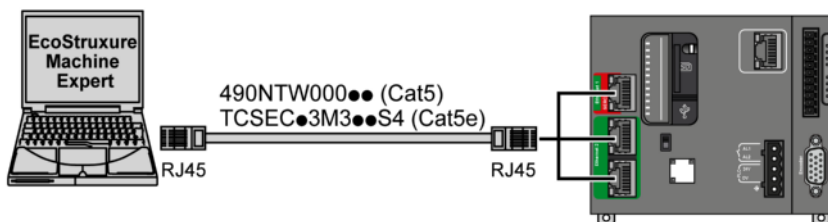

To connect the controller to the PC, do the following:

Step	Action
1	Connect the Ethernet cable to the PC.
2	Connect the Ethernet cable to any of the Ethernet ports on the controller.

Glossary

A

analog input:

Converts received voltage or current levels into numerical values. You can store and process these values within the logic controller.

application:

A program including configuration data, symbols, and documentation.

ASCII:

(American standard code for Information Interchange) A protocol for representing alphanumeric characters (letters, numbers, certain graphics, and control characters).

B

bps:

(bit per second) A definition of transmission rate, also given in conjunction with multiplier kilo (kbps) and mega (mbps).

C

CANopen:

An open industry-standard communication protocol and device profile specification (EN 50325-4).

CFC:

(continuous function chart) A graphical programming language (an extension of the IEC 61131-3 standard) based on the function block diagram language that works like a flowchart. However, no networks are used and free positioning of graphic elements is possible, which allows feedback loops. For each block, the inputs are on the left and the outputs on the right. You can link the block outputs to the inputs of other blocks to create complex expressions.

configuration:

The arrangement and interconnection of hardware components within a system and the hardware and software parameters that determine the operating characteristics of the system.

continuous function chart language:

A graphical programming language (an extension of the IEC61131-3 standard) based on the function block diagram language that works like a flowchart. However, no networks are used and free positioning of graphic elements is possible, which allows feedback loops. For each block, the inputs are on the left and the outputs on the right. You can link the block outputs to inputs of other blocks to create complex expressions.

controller:

Automates industrial processes (also known as programmable logic controller or programmable controller).

D

DIN:

(Deutsches Institut für Normung) A German institution that sets engineering and dimensional standards.

E

EIA rack:

(electronic industries alliance rack) A standardized (EIA 310-D, IEC 60297, and DIN 41494 SC48D) system for mounting various electronic modules in a stack or rack that is 19 inches (482.6 mm) wide.

EN:

EN identifies one of many European standards maintained by CEN (*European Committee for Standardization*), CENELEC (*European Committee for Electrotechnical Standardization*), or ETSI (*European Telecommunications Standards Institute*).

Ethernet:

A physical and data link layer technology for LANs, also known as IEEE 802.3.

F

FBD:

(function block diagram) One of 5 languages for logic or control supported by the standard IEC 61131-3 for control systems. Function block diagram is a graphically oriented programming language. It works with a list of networks, where each network contains a graphical structure of boxes and connection lines, which represents either a logical or arithmetic expression, the call of a function block, a jump, or a return instruction.

FE:

(functional Earth) A common grounding connection to enhance or otherwise allow normal operation of electrically sensitive equipment (also referred to as functional ground in North America).

In contrast to a protective Earth (protective ground), a functional earth connection serves a purpose other than shock protection, and may normally carry current. Examples of devices that use functional earth connections include surge suppressors and electromagnetic interference filters, certain antennas, and measurement instruments.

FreqGen:

(frequency generator) A function that generates a square wave signal with programmable frequency.

G

GRAFCET:

The functioning of a sequential operation in a structured and graphic form.

This is an analytical method that divides any sequential control system into a series of steps, with which actions, transitions, and conditions are associated.

H

HE10:

Rectangular connector for electrical signals with frequencies below 3 MHz, complying with IEC 60807-2.

HSC:

(high-speed counter) A function that counts pulses on the controller or on expansion module inputs.

I

I/O:

(input/output)

IEC 61131-3:

Part 3 of a 3-part IEC standard for industrial automation equipment. IEC 61131-3 is concerned with controller programming languages and defines 2 graphical and 2 textual programming language standards. The graphical programming languages are ladder diagram and function block diagram. The textual programming languages include structured text and instruction list.

IEC:

(international electrotechnical commission) A non-profit and non-governmental international standards organization that prepares and publishes international standards for electrical, electronic, and related technologies.

IL:

(instruction list) A program written in the language that is composed of a series of text-based instructions executed sequentially by the controller. Each instruction includes a line number, an instruction code, and an operand (refer to IEC 61131-3).

instruction list language:

A program written in the instruction list language that is composed of a series of text-based instructions executed sequentially by the controller. Each instruction includes a line number, an instruction code, and an operand (see IEC 61131-3).

IP 20:

(ingress protection) The protection classification according to IEC 60529 offered by an enclosure, shown by the letter IP and 2 digits. The first digit indicates 2 factors: helping protect persons and for equipment. The second digit indicates helping protect against water. IP 20 devices help protect against electric contact of objects larger than 12.5 mm, but not against water.

L

ladder diagram language:

A graphical representation of the instructions of a controller program with symbols for contacts, coils, and blocks in a series of rungs executed sequentially by a controller (see IEC 61131-3).

LD:

(ladder diagram) A graphical representation of the instructions of a controller program with symbols for contacts, coils, and blocks in a series of rungs executed sequentially by a controller (refer to IEC 61131-3).

N

NEMA:

(national electrical manufacturers association) The standard for the performance of various classes of electrical enclosures. The NEMA standards cover corrosion resistance, ability to help protect from rain, submersion, and so on. For IEC member countries, the IEC 60529 standard classifies the ingress protection rating for enclosures.

P

PE:

(*Protective Earth*) A common grounding connection to help avoid the hazard of electric shock by keeping any exposed conductive surface of a device at earth potential. To avoid possible voltage drop, no current is allowed to flow in this conductor (also referred to as *protective ground* in North America or as an equipment grounding conductor in the US national electrical code).

program:

The component of an application that consists of compiled source code capable of being installed in the memory of a logic controller.

PTO:

(*pulse train outputs*) A fast output that oscillates between off and on in a fixed 50-50 duty cycle, producing a square wave form. PTO is especially well suited for applications such as stepper motors, frequency converters, and servo motor control, among others.

PWM:

(*pulse width modulation*) A fast output that oscillates between off and on in an adjustable duty cycle, producing a rectangular wave form (though you can adjust it to produce a square wave).

R

RJ45:

A standard type of 8-pin connector for network cables defined for Ethernet.

RS-232:

A standard type of serial communication bus, based on 3 wires (also known as EIA RS-232C or V.24).

RS-485:

A standard type of serial communication bus, based on 2 wires (also known as EIA RS-485).

RTC:

(*real-time clock*) A battery-backed time-of-day and calendar clock that operates continuously, even when the controller is not powered for the life of the battery.

RxD:

The line that receives data from one source to another.

S

SFC:

(*sequential function chart*) A language that is composed of steps with associated actions, transitions with associated logic condition, and directed links between steps and transitions. (The SFC standard is defined in IEC 848. It is IEC 61131-3 compliant.)

SSI:

(*serial synchronous interface*) A common interface for relative and absolute measurement systems like encoders.

ST:

(*structured text*) A language that includes complex statements and nested instructions (such as iteration loops, conditional executions, or functions). ST is compliant with IEC 61131-3.

T

terminal block:

(terminal block) The component that mounts in an electronic module and provides electrical connections between the controller and the field devices.

TxD:

The line that sends data from one source to another.

Index

A	
accessories	31
B	
bus coupler specifications	28
C	
certifications and standards	44
communication ports	115
Ethernet ports	115, 117
Serial Line	121
USB Programming Port	119
D	
DIN rail	49
E	
Edge I/O NTS devices	15
Electrical Requirements Installation	54
Electromagnetic Susceptibility	44
Environmental Characteristics	42
expansion modules TMS	30
F	
fallback configuring modes	35
features key features	13
fieldbus interface specifications	28
G	
grounding	60
I	
inductive load	56
Input Management	33
installation logic/motion controller installation	45
Installation	42
Electrical Requirements	54
intended use	6
L	
Latching	33
logic/motion controller installation	45
M	
Machine Expert Protocol	121
mounting positions	46
O	
output management	34
output protection	56
P	
pin assignment encoder interface	112
Sercos	117
Power Supply	58
presentation TM262L01MESE8T	68
TM262L10MESE8T	73
TM262L20MESE8T	78
TM262M05MESS8T	83
TM262M15MESS8T	88
TM262M25MESS8T	93
TM262M35MESS8T	98
programming languages IL, LD, Grafcet	13
Q	
qualification of personnel	5
R	
real time clock	32
Run/Stop	35
S	
SD Card	36
Sercos port	116
Serial Line communication ports	121
short-circuit or over-current on transistor outputs	35
T	
TMS expansion modules	30
U	
USB Programming Port communication ports	119
W	
weight TM262L01MESE8T	72
TM262L10MESE8T	77
TM262L20MESE8T	82
TM262M05MESS8T	87
TM262M15MESS8T	92
TM262M25MESS8T	97
TM262M35MESS8T	102
wiring	54

Schneider Electric
35 rue Joseph Monier
92500 Rueil Malmaison
France

www.se.com

As standards, specifications, and design change from time to time, please ask for confirmation of the information given in this publication.

© 2026 Schneider Electric. All rights reserved.

EIO0000003659.12