

Modicon TM3

Expert I/O Modules

Hardware Guide

EIO0000003137.04
06/2024



Legal Information

The information provided in this document contains general descriptions, technical characteristics and/or recommendations related to products/solutions.

This document is not intended as a substitute for a detailed study or operational and site-specific development or schematic plan. It is not to be used for determining suitability or reliability of the products/solutions for specific user applications. It is the duty of any such user to perform or have any professional expert of its choice (integrator, specifier or the like) perform the appropriate and comprehensive risk analysis, evaluation and testing of the products/solutions with respect to the relevant specific application or use thereof.

The Schneider Electric brand and any trademarks of Schneider Electric SE and its subsidiaries referred to in this document are the property of Schneider Electric SE or its subsidiaries. All other brands may be trademarks of their respective owner.

This document and its content are protected under applicable copyright laws and provided for informative use only. No part of this document may be reproduced or transmitted in any form or by any means (electronic, mechanical, photocopying, recording, or otherwise), for any purpose, without the prior written permission of Schneider Electric.

Schneider Electric does not grant any right or license for commercial use of the document or its content, except for a non-exclusive and personal license to consult it on an "as is" basis.

Schneider Electric reserves the right to make changes or updates with respect to or in the content of this document or the format thereof, at any time without notice.

To the extent permitted by applicable law, no responsibility or liability is assumed by Schneider Electric and its subsidiaries for any errors or omissions in the informational content of this document, as well as any non-intended use or misuse of the content thereof.

Table of Contents

Safety Information	5
Qualification of Personnel	5
Intended Use	6
About the Book	7
TM3 Expert I/O Modules General Overview	13
TM3 Expert I/O Modules Description	14
General Description	14
Physical Description	15
Accessories	17
TM3 Expert I/O Modules Installation	18
TM3 Expert I/O Modules General Rules for Implementing	18
Environmental Characteristics	18
Certifications and Standards	20
TM3 Expert I/O Modules Installation	21
Installation and Maintenance Requirements	21
Installation Guidelines	22
Top Hat Section Rail (DIN rail)	25
Assembling a Module to a Controller or Receiver Module	27
Disassembling a Module from a Controller or Receiver Module	28
Direct Mounting on a Panel Surface	29
TM3 Expert I/O Modules Electrical Requirements	30
Wiring Best Practices	30
DC Power Supply Characteristics	34
Grounding the TM3 Expert I/O Modules	35
TM3 Expert Expansion Modules	38
TM3XTYS4 TeSys Module	39
TM3XTYS4 Presentation	39
TM3XTYS4 Characteristics	43
TM3XTYS4 Wiring Diagram	45
TM3XFHSC202 / TM3XFHSC202G Module	47
TM3XFHSC202 / TM3XFHSC202G Presentation	47
TM3XFHSC202 / TM3XFHSC202G Characteristics	49
TM3XFHSC202 / TM3XFHSC202G Wiring Diagram	52
TM3XHSC202 / TM3XHSC202G Module	54
TM3XHSC202 / TM3XHSC202G Presentation	54
TM3XHSC202 / TM3XHSC202G Characteristics	55
TM3XHSC202 / TM3XHSC202G Wiring Diagram	58
Glossary	61
Index	63

Safety Information

Important Information

Read these instructions carefully, and look at the equipment to become familiar with the device before trying to install, operate, service, or maintain it. The following special messages may appear throughout this documentation or on the equipment to warn of potential hazards or to call attention to information that clarifies or simplifies a procedure.



The addition of this symbol to a “Danger” or “Warning” safety label indicates that an electrical hazard exists which will result in personal injury if the instructions are not followed.



This is the safety alert symbol. It is used to alert you to potential personal injury hazards. Obey all safety messages that follow this symbol to avoid possible injury or death.

⚠ DANGER
DANGER indicates a hazardous situation which, if not avoided, will result in death or serious injury.

⚠ WARNING
WARNING indicates a hazardous situation which, if not avoided, could result in death or serious injury.

⚠ CAUTION
CAUTION indicates a hazardous situation which, if not avoided, could result in minor or moderate injury.

NOTICE
NOTICE is used to address practices not related to physical injury.

Please Note

Electrical equipment should be installed, operated, serviced, and maintained only by qualified personnel. No responsibility is assumed by Schneider Electric for any consequences arising out of the use of this material.

A qualified person is one who has skills and knowledge related to the construction and operation of electrical equipment and its installation, and has received safety training to recognize and avoid the hazards involved.

Qualification of Personnel

Only appropriately trained persons who are familiar with and understand the contents of this manual and all other pertinent product documentation are authorized to work on and with this product.

The qualified person must be able to detect possible hazards that may arise from parameterization, modifying parameter values and generally from mechanical, electrical, or electronic equipment. The qualified person must be familiar with the standards, provisions, and regulations for the prevention of industrial accidents, which they must observe when designing and implementing the system.

Intended Use

The products described or affected by this document, together with software, accessories, and options, are expansion modules, intended for industrial use according to the instructions, directions, examples, and safety information contained in the present document and other supporting documentation.

The product may only be used in compliance with all applicable safety regulations and directives, the specified requirements, and the technical data.

Prior to using the product, you must perform a risk assessment in view of the planned application. Based on the results, the appropriate safety-related measures must be implemented.

Since the product is used as a component in an overall machine or process, you must ensure the safety of persons by means of the design of this overall system.

Operate the product only with the specified cables and accessories. Use only genuine accessories and spare parts.

Any use other than the use explicitly permitted is prohibited and can result in unanticipated hazards.

About the Book

Document Scope

This guide describes the hardware implementation of TM3 expert modules. It provides the parts description, characteristics, wiring diagrams, and installation details for TM3 expert modules.

Validity Note

This document has been updated for the release of EcoStruxure™ Machine Expert V2.2.

This document has been updated for the release of EcoStruxure™ Machine Expert - Basic V1.3.

For product compliance and environmental information (RoHS, REACH, PEP, EOL, etc.), go to www.se.com/ww/en/work/support/green-premium/.

The characteristics of the products described in this document are intended to match the characteristics that are available on www.se.com. As part of our corporate strategy for constant improvement, we may revise the content over time to enhance clarity and accuracy. If you see a difference between the characteristics in this document and the characteristics on www.se.com, consider www.se.com to contain the latest information.

Available Languages of this Document

This document is available in these languages:

- English (EIO0000003137)
- French (EIO0000003138)
- German (EIO0000003139)
- Spanish (EIO0000003140)
- Italian (EIO0000003141)
- Chinese (EIO0000003142)
- Portuguese (EIO0000003428)
- Turkish (EIO0000003429)

Related Documents

Title of Documentation	Reference Number
Modicon TM3 Expansion Modules - Programming Guide (EcoStruxure Machine Expert - Basic)	EIO0000003345 (ENG) EIO0000003346 (FRA) EIO0000003347 (GER) EIO0000003348 (SPA) EIO0000003349 (ITA) EIO0000003350 (CHS) EIO0000003351 (POR) EIO0000003352 (TUR)
Modicon TM3 Expansion Modules - Programming Guide (EcoStruxure Machine Expert)	EIO0000003119 (ENG) EIO0000003120 (FRA) EIO0000003121 (GER) EIO0000003122 (SPA) EIO0000003123 (ITA) EIO0000003124 (CHS)
Modicon TM3 Expert I/O Modules - HSC Library Guide	EIO0000003683 (ENG) EIO0000003684 (FRE) EIO0000003685 (GER) EIO0000003686 (SPA) EIO0000003687 (ITA) EIO0000003688 (CHS) EIO0000003689 (POR) EIO0000003690 (TUR)
Modicon M221 Logic Controller - Hardware Guide	EIO0000003313 (ENG) EIO0000003314 (FRA) EIO0000003315 (GER) EIO0000003316 (SPA) EIO0000003317 (ITA) EIO0000003318 (CHS) EIO0000003319 (POR) EIO0000003320 (TUR)
Modicon M241 Logic Controller - Hardware Guide	EIO0000003083 (ENG) EIO0000003084 (FRA) EIO0000003085 (GER) EIO0000003086 (SPA) EIO0000003087 (ITA) EIO0000003088 (CHS)
Modicon M251 Logic Controller - Hardware Guide	EIO0000003101 (ENG) EIO0000003102 (FRA) EIO0000003103 (GER) EIO0000003104 (SPA) EIO0000003105 (ITA) EIO0000003106 (CHS)

Title of Documentation	Reference Number
Modicon M262 Logic/Motion Controller - Hardware Guide	EIO0000003659 (ENG)
	EIO0000003660 (FRA)
	EIO0000003661 (GER)
	EIO0000003662 (SPA)
	EIO0000003663 (ITA)
	EIO0000003664 (CHS)
	EIO0000003665 (POR)
EIO0000003666 (TUR)	
TM3XTYS4 Expert I/O Module - Instruction sheet	HRB59608
TM3X•HSC202• Expert I/O Modules - Instruction sheet	PHA44910

To find documents online, visit the Schneider Electric download center (www.se.com/ww/en/download/).

Product Related Information

⚠️⚠️ DANGER

HAZARD OF ELECTRIC SHOCK, EXPLOSION OR ARC FLASH

- Disconnect all power from all equipment including connected devices prior to removing any covers or doors, or installing or removing any accessories, hardware, cables, or wires except under the specific conditions specified in the appropriate hardware guide for this equipment.
- Always use a properly rated voltage sensing device to confirm the power is off where and when indicated.
- Replace and secure all covers, accessories, hardware, cables, and wires and confirm that a proper ground connection exists before applying power to the unit.
- Use only the specified voltage when operating this equipment and any associated products.

Failure to follow these instructions will result in death or serious injury.

⚠️ DANGER

POTENTIAL FOR EXPLOSION

- Only use this equipment in non-hazardous locations, or in locations that comply with Class I, Division 2, Groups A, B, C and D.
- Do not substitute components which would impair compliance to Class I, Division 2.
- Do not connect or disconnect equipment unless power has been removed or the location is known to be non-hazardous.
- Do not use the USB port(s), if so equipped, unless the location is known to be non-hazardous.

Failure to follow these instructions will result in death or serious injury.

⚠ WARNING**LOSS OF CONTROL**

- Perform a Failure Mode and Effects Analysis (FMEA), or equivalent risk analysis, of your application, and apply preventive and detective controls before implementation.
- Provide a fallback state for undesired control events or sequences.
- Provide separate or redundant control paths wherever required.
- Supply appropriate parameters, particularly for limits.
- Review the implications of transmission delays and take actions to mitigate them.
- Review the implications of communication link interruptions and take actions to mitigate them.
- Provide independent paths for control functions (for example, emergency stop, over-limit conditions, and error conditions) according to your risk assessment, and applicable codes and regulations.
- Apply local accident prevention and safety regulations and guidelines.¹
- Test each implementation of a system for proper operation before placing it into service.

Failure to follow these instructions can result in death, serious injury, or equipment damage.

¹ For additional information, refer to NEMA ICS 1.1 (latest edition), *Safety Guidelines for the Application, Installation, and Maintenance of Solid State Control* and to NEMA ICS 7.1 (latest edition), *Safety Standards for Construction and Guide for Selection, Installation and Operation of Adjustable-Speed Drive Systems* or their equivalent governing your particular location.

⚠ WARNING**UNINTENDED EQUIPMENT OPERATION**

- Only use software approved by Schneider Electric for use with this equipment.
- Update your application program every time you change the physical hardware configuration.

Failure to follow these instructions can result in death, serious injury, or equipment damage.

Information on Non-Inclusive or Insensitive Terminology

As a responsible, inclusive company, Schneider Electric is constantly updating its communications and products that contain non-inclusive or insensitive terminology. However, despite these efforts, our content may still contain terms that are deemed inappropriate by some customers.

Terminology Derived from Standards

The technical terms, terminology, symbols and the corresponding descriptions in the information contained herein, or that appear in or on the products themselves, are generally derived from the terms or definitions of international standards.

In the area of functional safety systems, drives and general automation, this may include, but is not limited to, terms such as *safety*, *safety function*, *safe state*, *fault*, *fault reset*, *malfunction*, *failure*, *error*, *error message*, *dangerous*, etc.

Among others, these standards include:

Standard	Description
IEC 61131-2:2007	Programmable controllers, part 2: Equipment requirements and tests.
ISO 13849-1:2023	Safety of machinery: Safety related parts of control systems. General principles for design.
EN 61496-1:2020	Safety of machinery: Electro-sensitive protective equipment. Part 1: General requirements and tests.
ISO 12100:2010	Safety of machinery - General principles for design - Risk assessment and risk reduction
EN 60204-1:2006	Safety of machinery - Electrical equipment of machines - Part 1: General requirements
ISO 14119:2013	Safety of machinery - Interlocking devices associated with guards - Principles for design and selection
ISO 13850:2015	Safety of machinery - Emergency stop - Principles for design
IEC 62061:2021	Safety of machinery - Functional safety of safety-related electrical, electronic, and electronic programmable control systems
IEC 61508-1:2010	Functional safety of electrical/electronic/programmable electronic safety-related systems: General requirements.
IEC 61508-2:2010	Functional safety of electrical/electronic/programmable electronic safety-related systems: Requirements for electrical/electronic/programmable electronic safety-related systems.
IEC 61508-3:2010	Functional safety of electrical/electronic/programmable electronic safety-related systems: Software requirements.
IEC 61784-3:2021	Industrial communication networks - Profiles - Part 3: Functional safety fieldbuses - General rules and profile definitions.
2006/42/EC	Machinery Directive
2014/30/EU	Electromagnetic Compatibility Directive
2014/35/EU	Low Voltage Directive

In addition, terms used in the present document may tangentially be used as they are derived from other standards such as:

Standard	Description
IEC 60034 series	Rotating electrical machines
IEC 61800 series	Adjustable speed electrical power drive systems
IEC 61158 series	Digital data communications for measurement and control – Fieldbus for use in industrial control systems

Finally, the term *zone of operation* may be used in conjunction with the description of specific hazards, and is defined as it is for a *hazard zone* or *danger zone* in the *Machinery Directive (2006/42/EC)* and *ISO 12100:2010*.

NOTE: The aforementioned standards may or may not apply to the specific products cited in the present documentation. For more information concerning the individual standards applicable to the products described herein, see the characteristics tables for those product references.

TM3 Expert I/O Modules General Overview

What's in This Part

TM3 Expert I/O Modules Description.....	14
TM3 Expert I/O Modules Installation	18

TM3 Expert I/O Modules Description

What's in This Chapter

General Description.....	14
Physical Description	15
Accessories	17

General Description

Introduction

The range of TM3 expert I/O expansion modules includes:

- TeSys modules
- High speed counting modules

TeSys modules are used to manage starters within TeSys system architectures.

High speed counting modules are used for counting functions and position detection. Events are only supported by the TM3XFHSC202 / TM3XFHSC202G modules.

TM3 Expert Modules

The following table shows the TM3 expert expansion modules, with corresponding terminal types:

Reference	Description	Terminal Type / Pitch
TM3XTYS4, page 39	TeSys module	4 front connectors RJ-45 1 removable power supply connector / 5.08 mm
TM3XFHSC202, page 47	High Speed Counting (HSC) module with events	Removable screw terminal blocks / 3.81 mm
TM3XFHSC202G, page 47	High Speed Counting (HSC) module with events	Removable spring terminal blocks / 3.81 mm
TM3XHSC202, page 54	High Speed Counting (HSC) module	Removable screw terminal blocks / 3.81 mm
TM3XHSC202G, page 54	High Speed Counting (HSC) module	Removable spring terminal blocks / 3.81 mm

Physical Description

Introduction

This section describes the physical characteristics of the TM3 expert expansion modules.

TeSys Modules

The following figure shows the main elements of the TM3XTYS4 expansion module:

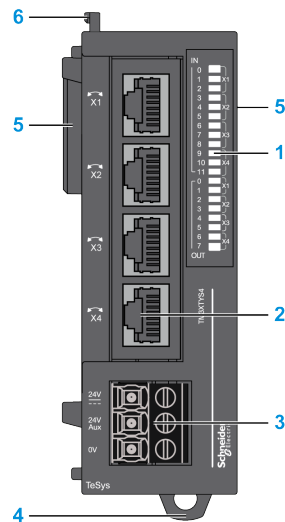

This table describes the main elements of the TM3XTYS4 expansion module shown above:

N°	Description	Refer to
1	LEDs for displaying the state of the I/O channels	–
2	TeSys RJ45 connectors	–
3	Power supply screw terminal block	Power Supply Wiring diagram, page 46
4	Clip-on lock for 35 mm (1.38 in.) top hat section rail (DIN-rail)	Top Hat Section Rail (DIN rail), page 25
5	Expansion connector for TM3 I/O bus (one on each side)	–
6	Locking device for attachment to the previous module	–

High Speed Counting Modules

The following figure shows the main elements of a TM3X•HSC202• expansion module:

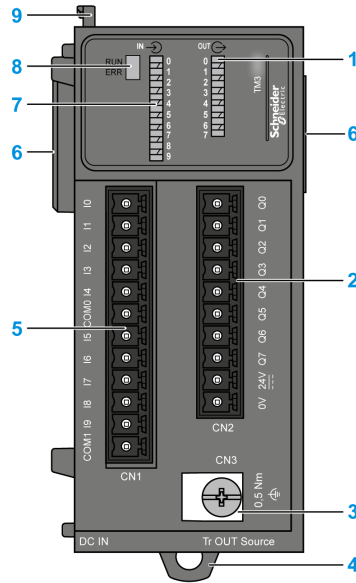

This table describes the main elements of the TM3X•HSC202• expansion module shown above:

N°	Description	Refer to
1	LEDs for displaying the state of the output channels	–
2	Removable outputs terminal block (screw or spring)	Wiring Best Practices, page 30
3	Functional ground screw	Grounding the TM3 Expert I/O Modules, page 35
4	Clip-on lock for 35 mm (1.38 in.) top hat section rail (DIN rail)	Top Hat Section Rail (DIN rail), page 25
5	Removable inputs terminal block (screw or spring)	Wiring Best Practices, page 30
6	Expansion connector for TM3 I/O bus (one on each side)	–
7	LEDs for displaying the state of the input channels	–
8	Module status LEDs	–
9	Locking device for attachment to the previous module	–

Accessories

Overview

This section describes the accessories and cables.

Accessories

Reference	Description	Use	Quantity
NSYTRAAB35	End brackets	Helps secure the logic controller or receiver module and their expansion modules on a top hat section rail (DIN rail).	1
TMAM2	Mounting kit	Mounts the controller and I/O modules directly to a flat, vertical panel.	
TM200RSRCEMC	Shielding take-up clip	Mounts and connects the ground to the cable shielding.	25-pack

For top hat section rails (DIN rails), refer to Top Hat Section Rail (DIN rail), page 25.

Cables

Reference	Description	Use	Length
LU9R**	Connection cables equipped with an RJ45 connector at both ends.	Connects the TM3XTYS4 module to the TeSys system.	0.3, 1 or 3 m (0.98, 3.28 or 9.84 ft)

TM3 Expert I/O Modules Installation

What's in This Chapter

TM3 Expert I/O Modules General Rules for Implementing.....	18
TM3 Expert I/O Modules Installation	21
TM3 Expert I/O Modules Electrical Requirements	30

TM3 Expert I/O Modules General Rules for Implementing

Environmental Characteristics

Enclosure Requirements

TM3 expansion module components are designed as Zone B, Class A industrial equipment according to IEC/CISPR Publication 11. If they are used in environments other than those described in these standards, or in environments that do not meet the specifications in this manual the ability to meet electromagnetic compatibility requirements in the presence of conducted and/or radiated interference may be reduced.

All TM3 expansion module components meet European Community (CE) requirements for open equipment as defined by IEC/EN 61131-2. You must install them in an enclosure designed for the specific environmental conditions and to minimize the possibility of unintended contact with hazardous voltages. Use metal enclosures to improve the electromagnetic immunity of your TM3 expansion module components. Use enclosures with a keyed locking mechanism to minimize unauthorized access.

Environmental Characteristics

All the TM3 expansion module components are electrically isolated between the internal electronic circuit and the input/output channels. This equipment meets CE requirements as indicated in the table below. This equipment is intended for use in a Pollution Degree 2 industrial environment.

⚠ WARNING

UNINTENDED EQUIPMENT OPERATION

Do not exceed any of the rated values specified in the environmental and electrical characteristics tables.

Failure to follow these instructions can result in death, serious injury, or equipment damage.

The following table shows the general environmental characteristics:

Characteristic	Minimum Specification	Tested Range	
		TM3XTYS4	TM3X•HSC202•
Standard compliance	IEC/EN 61131-2 UL/CSA 61010-1, -2-201	–	
Ambient operating temperature	–	Horizontal installation: -10...55 °C (14...131 °F)	Horizontal installation: -20...60 °C (-4...140 °F)
	–	Vertical installation: -10...35 °C (14...95 °F)	Vertical installation: -20...50 °C (-4...122 °F)
Storage and transport temperature	–	-25...70 °C (-13...158 °F)	-40...85 °C (-40...185 °F)
Relative humidity	–	Transport and storage: 10...95 % (non-condensing)	
	–	Operation: 10...95 % (non-condensing)	
Degree of pollution	IEC/EN 60664-1	2	
Degree of protection	IEC/EN 61131-2	IP20	
Corrosion immunity	–	Atmosphere free from corrosive gases	
Operating altitude	–	0...2000 m (0...6560 ft)	
Storage altitude	–	0...3000 m (0...9843 ft)	
Vibration resistance	IEC/EN 61131-2	Panel mounting or mounted on a top hat section rail (DIN rail): <ul style="list-style-type: none"> • 10 mm (0.39 in) fixed amplitude from 5...8.7 Hz • 29.4 m/s² (96.45 ft/s²) (3 g_n) fixed acceleration from 8.7...150 Hz 	Panel mounting or mounted on a top hat section rail (DIN rail): <ul style="list-style-type: none"> • 3.5 mm (0.13 in) fixed amplitude from 2...8.4 Hz • 9.8 m/s² or 32.15 ft/s² (1 g_n) fixed acceleration from 8.4...200 Hz
Mechanical shock resistance	–	147 m/s ² or 482.28 ft/s ² (15 g _n) for a duration of 11 ms	
<p>NOTE: The tested ranges may indicate values beyond that of the IEC Standard. However, our internal standards define what is necessary for industrial environments. In all cases, we uphold the minimum specification if indicated.</p>			

Electromagnetic Susceptibility

The TM3 expansion module components meet electromagnetic susceptibility specifications as indicated in the following table:

Characteristic	Minimum Specification	Tested Range	
		TM3XTYS4	TM3X•HSC202•
Electrostatic discharge	IEC/EN 61000-4-2	8 kV (air discharge) 4 kV (contact discharge)	
Radiated electromagnetic field	IEC/EN 61000-4-3	10 V/m (80...1000 MHz) 3 V/m (1.4...2 GHz) 1 V/m (2...3 GHz)	
Magnetic field	IEC/EN 61000-4-8	30 A/m 50 Hz, 60 Hz	n/a
Fast transients burst	IEC/EN 61000-4-4	24 Vdc I/Os: 1 kV (CM ¹ and DM ²)	24 Vdc I/Os: 2 kV (clamp)
			Digital I/Os: 1 kV (clamp)
Surge immunity	IEC/EN 61000-4-5 IEC/EN 61131-2	DC power lines:	n/a
		<ul style="list-style-type: none"> • 1 kV (CM¹) • 0.5 kV (DM²) 	
		24 Vdc I/Os: 1 kV (CM ¹)	
		Shielded cable (between shield and ground): 1 kV (CM ¹)	
Induced electromagnetic field	IEC/EN 61000-4-6	10 Vrms (0.15...80 MHz)	
Conducted emission	IEC 61000-6-4	AC power line:	DC power line:
		<ul style="list-style-type: none"> • 0.15...0.5 MHz: 79 dBμV/m QP / 66 dBμV/m AV • 0.5...300 MHz: 73 dBμV/m QP / 60 dBμV/m AV 	
		AC/DC power line:	<ul style="list-style-type: none"> • 10...150 kHz: 120...69 dBμV/m QP • 150...1500 kHz: 79...63 dBμV/m QP • 1.5...30 MHz: 63 dBμV/m QP
Radiated emission	IEC 61000-6-4	30...230 MHz: 40 dB μ V/m QP 230...1000 MHz: 47 dB μ V/m QP	
1 Common Mode 2 Differential Mode NOTE: The tested ranges may indicate values beyond that of the IEC Standard. However, our internal standards define what is necessary for industrial environments. In all cases, we uphold the minimum specification if indicated.			

Certifications and Standards

Introduction

For information on certifications and conformance to standards, go to www.se.com.

For product compliance and environmental information (RoHS, REACH, PEP, EOL, etc.), go to www.se.com/green-premium.

TM3 Expert I/O Modules Installation

Installation and Maintenance Requirements

Before Starting

Read and understand this chapter before beginning the installation of your system.

The use and application of the information contained herein require expertise in the design and programming of automated control systems. Only you, the user, machine builder or integrator, can be aware of all the conditions and factors present during installation and setup, operation, and maintenance of the machine or process, and can therefore determine the automation and associated equipment and the related safeties and interlocks which can be effectively and properly used. When selecting automation and control equipment, and any other related equipment or software, for a particular application, you must also consider any applicable local, regional or national standards and/or regulations.

Pay particular attention in conforming to any safety information, different electrical requirements, and normative standards that would apply to your machine or process in the use of this equipment.

Disconnecting Power

All options and modules should be assembled and installed before installing the control system on a mounting rail, onto a mounting plate or in a panel. Remove the control system from its mounting rail, mounting plate or panel before disassembling the equipment.

⚠️⚠️ DANGER
HAZARD OF ELECTRIC SHOCK, EXPLOSION OR ARC FLASH
<ul style="list-style-type: none"> • Disconnect all power from all equipment including connected devices prior to removing any covers or doors, or installing or removing any accessories, hardware, cables, or wires except under the specific conditions specified in the appropriate hardware guide for this equipment. • Always use a properly rated voltage sensing device to confirm the power is off where and when indicated. • Replace and secure all covers, accessories, hardware, cables, and wires and confirm that a proper ground connection exists before applying power to the unit. • Use only the specified voltage when operating this equipment and any associated products.
Failure to follow these instructions will result in death or serious injury.

Programming Considerations

⚠️ WARNING
UNINTENDED EQUIPMENT OPERATION
<ul style="list-style-type: none"> • Only use software approved by Schneider Electric for use with this equipment. • Update your application program every time you change the physical hardware configuration.
Failure to follow these instructions can result in death, serious injury, or equipment damage.

Operating Environment

In addition to the **Environmental Characteristics**, refer to **Product Related Information** in the beginning of the present document for important information regarding installation in hazardous locations for this specific equipment.

⚠ WARNING

UNINTENDED EQUIPMENT OPERATION

Install and operate this equipment according to the conditions described in the Environmental Characteristics.

Failure to follow these instructions can result in death, serious injury, or equipment damage.

Installation Considerations

⚠ WARNING

UNINTENDED EQUIPMENT OPERATION

- Use appropriate safety interlocks where personnel and/or equipment hazards exist.
- Install and operate this equipment in an enclosure appropriately rated for its intended environment and secured by a keyed or tooled locking mechanism.
- Use the sensor and actuator power supplies only for supplying power to the sensors or actuators connected to the module.
- Power line and output circuits must be wired and fused in compliance with local and national regulatory requirements for the rated current and voltage of the particular equipment.
- Do not use this equipment in safety-critical machine functions unless the equipment is otherwise designated as functional safety equipment and conforming to applicable regulations and standards.
- Do not disassemble, repair, or modify this equipment.
- Do not connect any wiring to reserved, unused connections, or to connections designated as No Connection (N.C.).

Failure to follow these instructions can result in death, serious injury, or equipment damage.

NOTE: JDYX2 or JDYX8 fuse types are cULus-recognized.

Installation Guidelines

Introduction

TM3 expansion modules are assembled by connecting them to a logic controller or receiver module.

The logic controller or receiver module and their expansion modules can be installed on a top hat section rail (DIN rail).

Mounting Position and Minimum Clearances

The mounting position and minimum clearances of the expansion modules must conform with the rules defined for the appropriate hardware system. Refer to the *Installation chapter* in the *Controller Hardware* documentation for your specific controller.

▲ WARNING

UNINTENDED EQUIPMENT OPERATION

- Place devices dissipating the most heat at the top of the cabinet and ensure adequate ventilation.
- Avoid placing this equipment next to or above devices that might cause overheating.
- Install the equipment in a location providing the minimum clearances from all adjacent structures and equipment as directed in this document.
- Install all equipment in accordance with the specifications in the related documentation.

Failure to follow these instructions can result in death, serious injury, or equipment damage.

Correct Mounting Position

To obtain optimal operating characteristics, the TM3 Expert I/O Modules should be mounted horizontally on a vertical plane as shown in the figure below:

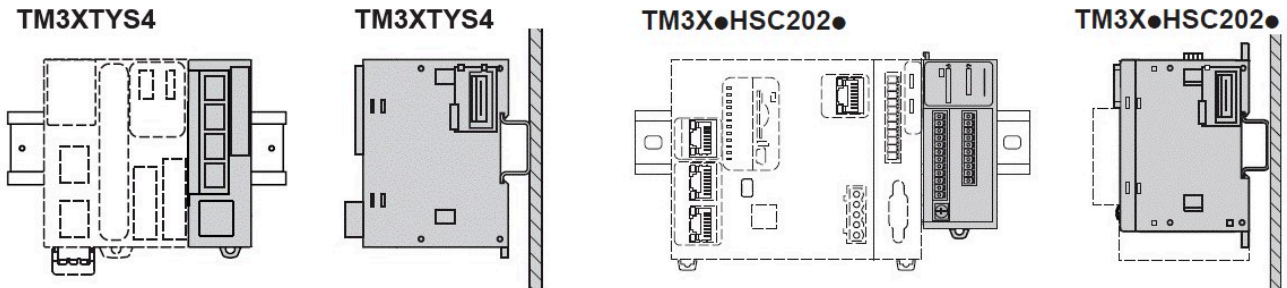

Acceptable Mounting Position

The TM3 Expert I/O Modules can also be mounted vertically on a vertical plane as shown below:

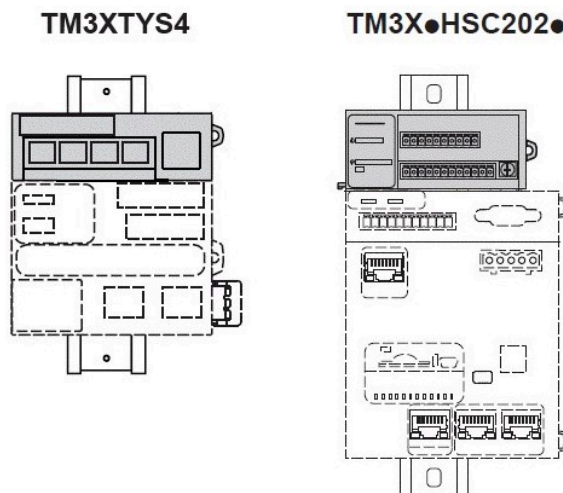

Incorrect Mounting Positions

The TM3 Expert I/O Modules should only be positioned as shown in the Correct Mounting Position, page 23 figure. The figures below show the incorrect mounting positions:

TM3XTYS4

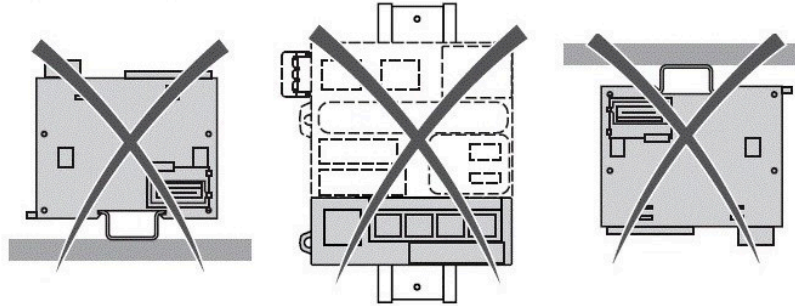

TM3X●HSC202●

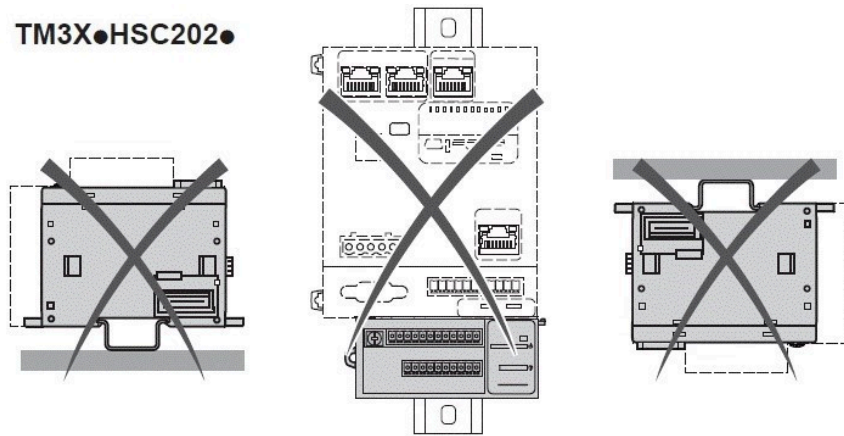

Top Hat Section Rail (DIN rail)

Dimensions of Top Hat Section Rail DIN Rail

You can mount the controller or receiver and their expansions on a 35 mm (1.38 in.) top hat section rail (DIN rail). The DIN rail can be attached to a smooth mounting surface or suspended from an EIA rack or mounted in a NEMA cabinet.

Symmetric Top Hat Section Rails (DIN Rail)

The following illustration and table indicate the references of the top hat section rails (DIN rail) for the wall-mounting range:

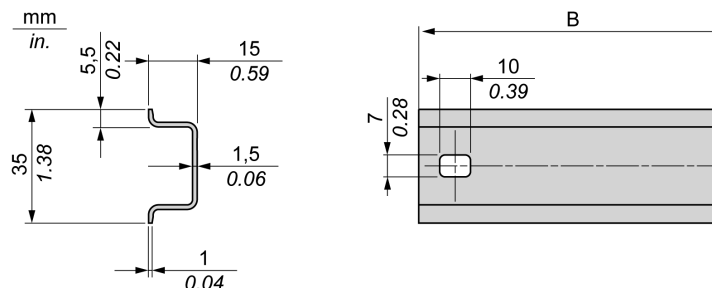

Reference	Type	Perforated	Rail Length (B)
NSYS DR50A	A	At each end	450 mm (17.71 in.)
NSYS DR60A	A	At each end	550 mm (21.65 in.)
NSYS DR80A	A	At each end	750 mm (29.52 in.)
NSYS DR100A	A	At each end	950 mm (37.40 in.)

The following illustration and table indicate the references of the symmetric top hat section rails (DIN rail) of 2000 mm (78.74 in.):

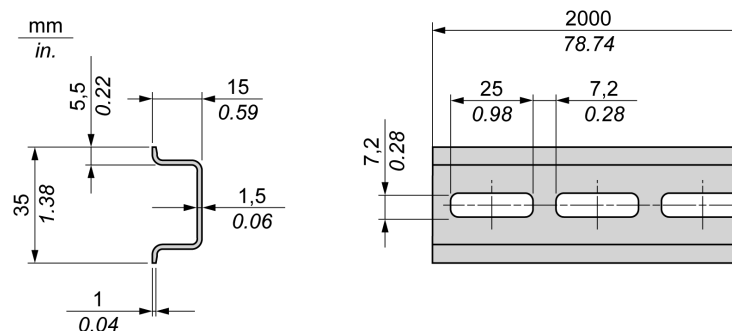

Reference	Type	Perforated	Rail Length
NSYS DR200	A	No	2000 mm (78.74 in.)
NSYS DR200D	A	Yes	

Double-Profile Top Hat Section Rails (DIN rail)

The following illustration and table indicate the references of the double-profile top hat section rails (DIN rail) of 2000 mm (78.74 in.):

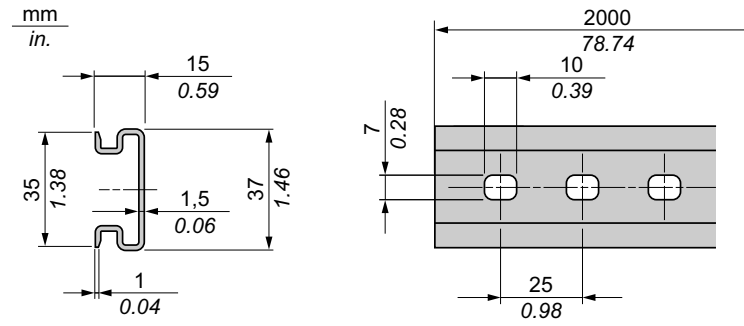

Reference	Type	Perforated	Rail Length
NSYDPR200	-	No	2000 mm (78.74 in.)
NSYDPR200D	-	Yes	

Assembling a Module to a Controller or Receiver Module

Introduction

This section describes how to assemble an expansion module to a controller, receiver module or other modules.

⚡⚠ DANGER

HAZARD OF ELECTRIC SHOCK, EXPLOSION OR ARC FLASH

- Disconnect all power from all equipment including connected devices prior to removing any covers or doors, or installing or removing any accessories, hardware, cables, or wires except under the specific conditions specified in the appropriate hardware guide for this equipment.
- Always use a properly rated voltage sensing device to confirm the power is off where and when indicated.
- Replace and secure all covers, accessories, hardware, cables, and wires and confirm that a proper ground connection exists before applying power to the unit.
- Use only the specified voltage when operating this equipment and any associated products.

Failure to follow these instructions will result in death or serious injury.

After connecting new modules to the controller, either directly or through a transmitter/receiver, update and reupload your application program before placing the system back in service. If you do not revise your application program to reflect the addition of new modules, I/O located on the expansion bus may no longer operate normally.

⚠ WARNING

UNINTENDED EQUIPMENT OPERATION

- Only use software approved by Schneider Electric for use with this equipment.
- Update your application program every time you change the physical hardware configuration.

Failure to follow these instructions can result in death, serious injury, or equipment damage.

Assembling a Module to a Controller or Receiver Module

The following procedure shows how to assemble a controller or receiver module and a module together:

Step	Action
1	Remove all power and dismount any existing controller I/O assembly from its DIN mounting.
2	Remove the expansion connector sticker from the controller or the outermost installed expansion module.
3	Verify that the locking device, page 15 on the new module is in the upper position.
4	Align the internal bus connector on the left side of the module with the internal bus connector on the right side of the controller, receiver module or expansion module.
5	Press the new module towards the controller, receiver module or expansion module until it is securely in place.
6	Push down the locking device, page 15 on the top of the new module to lock it to the controller, receiver module or previously installed expansion module.

Disassembling a Module from a Controller or Receiver Module

Introduction

This section describes how to disassemble a module from a controller or receiver module.

DANGER

HAZARD OF ELECTRIC SHOCK, EXPLOSION OR ARC FLASH

- Disconnect all power from all equipment including connected devices prior to removing any covers or doors, or installing or removing any accessories, hardware, cables, or wires except under the specific conditions specified in the appropriate hardware guide for this equipment.
- Always use a properly rated voltage sensing device to confirm the power is off where and when indicated.
- Replace and secure all covers, accessories, hardware, cables, and wires and confirm that a proper ground connection exists before applying power to the unit.
- Use only the specified voltage when operating this equipment and any associated products.

Failure to follow these instructions will result in death or serious injury.

Disassembling a Module from a Controller or Receiver Module

The following procedure describes how to disassemble a module from a controller or receiver module:

Step	Action
1	Remove all power from the control system.
2	Dismount the assembled controller and modules from the mounting rail.
3	Push up the locking device, page 15 from the bottom of the module to disengage it from the controller or the receiver module.
4	Pull apart the module from the controller or the receiver module.

Direct Mounting on a Panel Surface

Overview

This section shows how to install the TM3 expansion module using the Panel Mounting Kit. This section also provides mounting hole layout for all modules.

Installing the Panel Mounting Kit

The following procedure shows how to install a mounting strip:

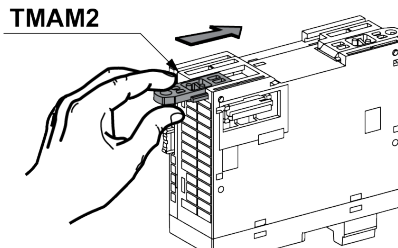
Step	Action
1	Insert the mounting strip TMAM2 into the slot at the top of the module. 

Mounting Hole Layout

The following diagram shows the mounting holes for the TM3XTYS4 expansion modules:

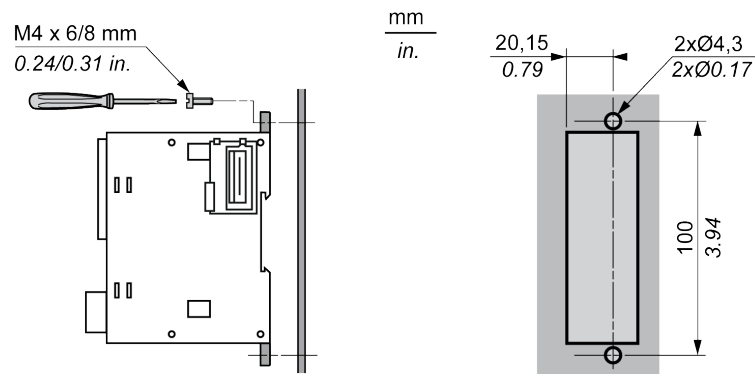

The following diagram shows the mounting holes for the TM3X•HSC202• expansion modules:

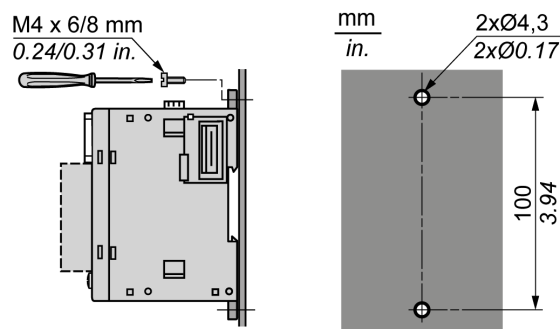

TM3 Expert I/O Modules Electrical Requirements

Wiring Best Practices

Overview

This section describes the wiring guidelines and associated best practices to be respected when using the TM3 system.

DANGER

HAZARD OF ELECTRIC SHOCK, EXPLOSION OR ARC FLASH

- Disconnect all power from all equipment including connected devices prior to removing any covers or doors, or installing or removing any accessories, hardware, cables, or wires except under the specific conditions specified in the appropriate hardware guide for this equipment.
- Always use a properly rated voltage sensing device to confirm the power is off where and when indicated.
- Replace and secure all covers, accessories, hardware, cables, and wires and confirm that a proper ground connection exists before applying power to the unit.
- Use only the specified voltage when operating this equipment and any associated products.

Failure to follow these instructions will result in death or serious injury.

WARNING

LOSS OF CONTROL

- Perform a Failure Mode and Effects Analysis (FMEA), or equivalent risk analysis, of your application, and apply preventive and detective controls before implementation.
- Provide a fallback state for undesired control events or sequences.
- Provide separate or redundant control paths wherever required.
- Supply appropriate parameters, particularly for limits.
- Review the implications of transmission delays and take actions to mitigate them.
- Review the implications of communication link interruptions and take actions to mitigate them.
- Provide independent paths for control functions (for example, emergency stop, over-limit conditions, and error conditions) according to your risk assessment, and applicable codes and regulations.
- Apply local accident prevention and safety regulations and guidelines.¹
- Test each implementation of a system for proper operation before placing it into service.

Failure to follow these instructions can result in death, serious injury, or equipment damage.

¹ For additional information, refer to NEMA ICS 1.1 (latest edition), *Safety Guidelines for the Application, Installation, and Maintenance of Solid State Control* and to NEMA ICS 7.1 (latest edition), *Safety Standards for Construction and Guide for Selection, Installation and Operation of Adjustable-Speed Drive Systems* or their equivalent governing your particular location.

Wiring Guidelines

The following rules must be applied when wiring a TM3 system:

- I/O and communication wiring must be kept separate from the power wiring. Route these 2 types of wiring in separate cable ducting.
- Verify that the operating conditions and environment are within the specification values.
- Use proper wire sizes to meet voltage and current requirements.
- Use minimum 60 °C (140 °F) copper conductors for TM3XTYS4.
- Use minimum 90 °C (194 °F) copper conductors for TM3X•HSC202•.
- Use twisted-pair, shielded cables for analog, and/or fast I/O.
- Use twisted-pair, shielded cables for networks, and field bus.

▲ WARNING
UNINTENDED EQUIPMENT OPERATION
<ul style="list-style-type: none"> • Use shielded cables for all fast I/O, analog I/O, and communication signals. • Ground cable shields for all fast I/O, analog I/O, and communication signals at a single point¹. • Route communications and I/O cables separately from power cables.
Failure to follow these instructions can result in death, serious injury, or equipment damage.

¹Multipoint grounding is permissible if connections are made to an equipotential ground plane dimensioned to help avoid cable shield damage in the event of power system short-circuit currents.

NOTE: Surface temperatures may exceed 60 °C (140 °F).

To conform to IEC 61010 standards, route primary wiring (wires connected to power mains) separately and apart from secondary wiring (extra low voltage wiring coming from intervening power sources). If that is not possible, double insulation is required such as conduit or cable gains.

Rules for Removable Screw Terminal Block

The following tables show the cable types and wire sizes for a **3.81 pitch** removable screw terminal block (I/Os and power supply):

$\frac{\text{mm}}{\text{in.}}$ 9 0.35	mm ²	0.14...1.5	0.14...1.5	0.25...1.5	0.25...0.5	2 x 0.14...0.5	2 x 0.14...0.75	2 x 0.25...0.34	2 x 0.5
AWG	26...16	26...16	22...16	22...20	2 x 26...20	2 x 26...20	2 x 24...22	2 x 20	
 Ø 2,5 mm (0.1 in.)				N•m	0.28				
				lb-in	2.48				

The following tables show the cable types and wire sizes for a **5.08 pitch** removable screw terminal block (I/Os and power supply):

$\frac{\text{mm}}{\text{in.}}$ 7 0.28	mm ²	0.2...2.5	0.2...2.5	0.25...2.5	0.25...2.5	2 x 0.2...1	2 x 0.2...1.5	2 x 0.25...1	2 x 0.5...1.5
AWG	24...14	24...14	23...14	23...14	2 x 24...17	2 x 24...16	2 x 23...17	2 x 20...16	
 Ø 3,5 mm (0.14 in.)				N•m	0.49				
				lb-in	4.34				

The use of copper conductors is required.





⚠ DANGER**FIRE HAZARD**

- Use only the correct wire sizes for the maximum current capacity of the I/O channels and power supplies.
- For relay output (2 A) wiring, use conductors of at least 0.5 mm² (AWG 20) with a temperature rating of at least 80 °C (176 °F).
- For common conductors of relay output wiring (7 A), or relay output wiring greater than 2 A, use conductors of at least 1.0 mm² (AWG 16) with a temperature rating of at least 80 °C (176 °F).



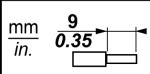



Failure to follow these instructions will result in death or serious injury.

Rules for Removable Spring Terminal Block

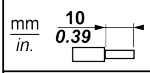
The following tables show the cable types and wire sizes for a **3.81 pitch** removable spring terminal block (I/Os and power supply):

				
mm ²	0.5...1.5	0.5...1.5	0.25...1.0	0.25...0.5
AWG	21...16	21...16	23...18	23...21

The following tables show the cable types and wire sizes for a **5.08 pitch** removable spring terminal block (I/Os and power supply):

					
mm ²	0.2...2.5	0.2...2.5	0.25...2.5	0.25...2.5	2 x 0.5...1
AWG	24...14	24...14	23...14	23...14	2 x 20...17

The use of copper conductors is required.

⚠ DANGER**FIRE HAZARD**

- Use only the correct wire sizes for the maximum current capacity of the I/O channels and power supplies.
- For relay output (2 A) wiring, use conductors of at least 0.5 mm² (AWG 20) with a temperature rating of at least 80 °C (176 °F).
- For common conductors of relay output wiring (7 A), or relay output wiring greater than 2 A, use conductors of at least 1.0 mm² (AWG 16) with a temperature rating of at least 80 °C (176 °F).

Failure to follow these instructions will result in death or serious injury.

The spring clamp connectors of the terminal block are designed for only one wire or one cable end. Two wires to the same connector must be installed with a double wire cable end to help prevent loosening.

⚡ ⚠ DANGER**LOOSE WIRING CAUSES ELECTRIC SHOCK**

Do not insert more than one wire per connector of the spring terminal blocks unless using a double wire cable end (ferrule).

Failure to follow these instructions will result in death or serious injury.

Protecting Outputs from Inductive Load Damage

Depending on the load, a protection circuit may be needed for the outputs on the controllers and certain modules. Inductive loads using DC voltages may create voltage reflections resulting in overshoot that will damage or shorten the life of output devices.

⚠ CAUTION
OUTPUT CIRCUIT DAMAGE DUE TO INDUCTIVE LOADS
Use an appropriate external protective circuit or device to reduce the risk of inductive direct current load damage.
Failure to follow these instructions can result in injury or equipment damage.

If your controller or module contains relay outputs, these types of outputs can support up to 240 Vac. Inductive damage to these types of outputs can result in welded contacts and loss of control. Each inductive load must include a protection device such as a peak limiter, RC circuit or flyback diode. Capacitive loads are not supported by these relays.

⚠ WARNING
RELAY OUTPUTS WELDED CLOSED
<ul style="list-style-type: none"> • Always protect relay outputs from inductive alternating current load damage using an appropriate external protective circuit or device. • Do not connect relay outputs to capacitive loads.
Failure to follow these instructions can result in death, serious injury, or equipment damage.

AC-driven contactor coils are, under certain circumstances, inductive loads that generate pronounced high-frequency interference and electrical transients when the contactor coil is de-energized. This interference may cause the logic controller to detect an I/O bus error.

⚠ WARNING
CONSEQUENTIAL LOSS OF CONTROL
Install an RC surge suppressor or similar means, such as an interposing relay, on each TM3 expansion module relay output when connecting to AC-driven contactors or other forms of inductive loads.
Failure to follow these instructions can result in death, serious injury, or equipment damage.

Protective circuit A: this protection circuit can be used for both AC and DC load power circuits.

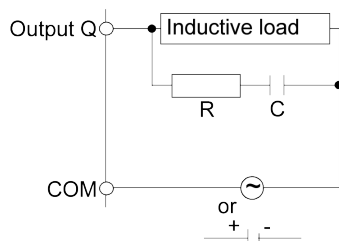

C Value from 0.1 to 1 μ F

R Resistor of approximately the same resistance value as the load

Protective circuit B: this protection circuit can be used for DC load power circuits.

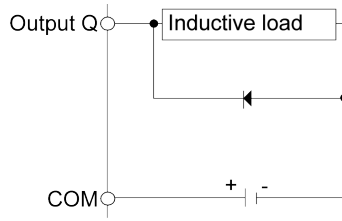

Use a diode with the following ratings:

- Reverse withstand voltage: power voltage of the load circuit x 10.
- Forward current: more than the load current.

Protective circuit C: this protection circuit can be used for both AC and DC load power circuits.

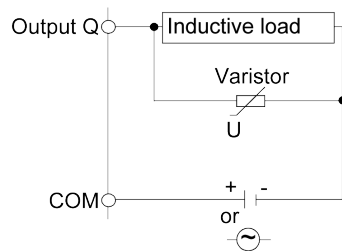

In applications where the inductive load is switched on and off frequently and/or rapidly, ensure that the continuous energy rating (J) of the varistor exceeds the peak load energy by 20 % or more.

DC Power Supply Characteristics

Overview

The TM3 expert I/O expansion modules require a power supply with a nominal voltage of 24 Vdc. The 24 Vdc power supply must be rated Protective Extra Low Voltage (PELV) according to IEC 61140. This power supply is isolated between the electrical input and output circuits of the power supply.

⚠ WARNING

POTENTIAL OF OVERHEATING AND FIRE

- Do not connect the equipment directly to line voltage.
- Use only isolating PELV power supplies and circuits to supply power to the equipment¹.

Failure to follow these instructions can result in death, serious injury, or equipment damage.

¹ For compliance to UL (Underwriters Laboratories) requirements, the power supply must also conform to the various criteria of NEC Class 2, and be inherently current limited to a maximum power output availability of less than 100 VA (approximately 4 A at nominal voltage), or not inherently limited but with an additional protection device such as a circuit breaker or fuse meeting the requirements of clause 9.4 Limited-energy circuit of UL 61010-1. In all cases, the current limit should never exceed that of the electric characteristics and wiring diagrams for the equipment described in the present documentation. In all cases, the power supply must be grounded, and you must separate Class 2 circuits from other circuits. If the indicated rating of the electrical characteristics or wiring diagrams are greater than the specified current limit, multiple Class 2 power supplies may be used.

DC Power Supply Wiring Diagram

This section applies **only** to TM3XTYS4 expansion modules. It is not valid for TM3X•HSC202• expansion modules.

The following figure shows the wiring of the DC power supply:

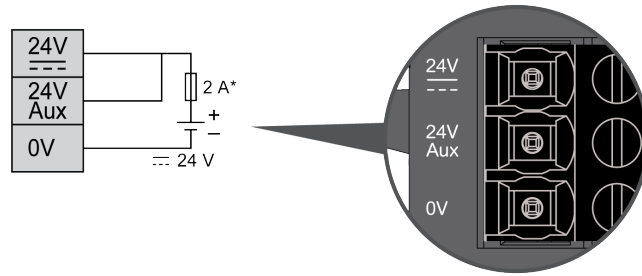

* Type T fuse

24 Vdc Aux is dedicated to input power supply.

24 Vdc is dedicated to output power supply.

Grounding the TM3 Expert I/O Modules

Overview

Due to the effects of electromagnetic interference, cables carrying fast I/O, analog I/O, and the fieldbus communication signals must be shielded.

⚠ WARNING

UNINTENDED EQUIPMENT OPERATION

- Use shielded cables for all fast I/O, analog I/O, and communication signals.
- Ground cable shields for all fast I/O, analog I/O, and communication signals at a single point¹.
- Route communications and I/O cables separately from power cables.

Failure to follow these instructions can result in death, serious injury, or equipment damage.

¹Multipoint grounding is permissible if connections are made to an equipotential ground plane dimensioned to help avoid cable shield damage in the event of power system short-circuit currents.

The use of shielded cables requires compliance with the following wiring rules:

- For protective earth ground connections (PE), metal conduit or ducting can be used for part of the shielding length, provided there is no break in the continuity of the ground connections. For functional earth ground (FE), the shielding is intended to attenuate electromagnetic interference and the shielding must be continuous for the length of the cable. If the purpose is both functional and protective, as is often the case for communication cables, the cable must have continuous shielding.
- Wherever possible, keep cables carrying one type of signal separate from the cables carrying other types of signals or power.

Shielded Cables Connections

Cables carrying fast I/O, analog I/O, and the fieldbus communication signals must be shielded. The shielding must be securely connected to ground. Fast I/O and analog I/O shields may be connected either to the functional earth ground (FE) or to the protective earth ground (PE) of your TM3 expansion module. The fieldbus

communication cable shields must be connected to the protective earth ground (PE) with a connecting clamp secured to the conductive backplane of your installation.

Protective Earth Ground (PE) on the Backplane

The protective earth ground (PE) is connected to the conductive backplane by a heavy-duty wire, usually a braided copper cable with the maximum allowable cable section.

Functional Earth Ground (FE) on the DIN Rail

The DIN Rail for your TM3 system is common with the functional earth ground (FE) plane and must be mounted on a conductive backplane.

⚠ WARNING
UNINTENDED EQUIPMENT OPERATION
Connect the DIN rail to the functional earth ground (FE) of your installation.
Failure to follow these instructions can result in death, serious injury, or equipment damage.

Functional Earth Ground (FE) Connections

This section applies **only** to TM3X•HSC202• expansion modules. It is not valid for TM3XTYS4 expansion modules.

The following diagram shows how to wire the screw to the functional earth ground (FE):

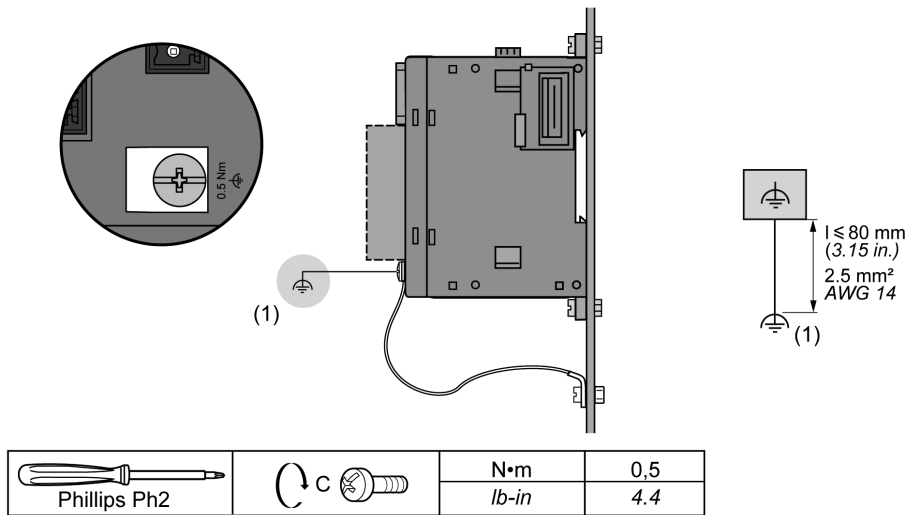

(1) Functional earth ground (FE)

Applying torque above the limit may damage the terminal screw or threads.

NOTICE
INOPERABLE EQUIPMENT
Do not tighten screw terminals beyond the specified maximum torque (N•m / lb-in.).
Failure to follow these instructions can result in equipment damage.

The following diagram shows how to connect the input and output cable shielding to the functional earth ground (FE):

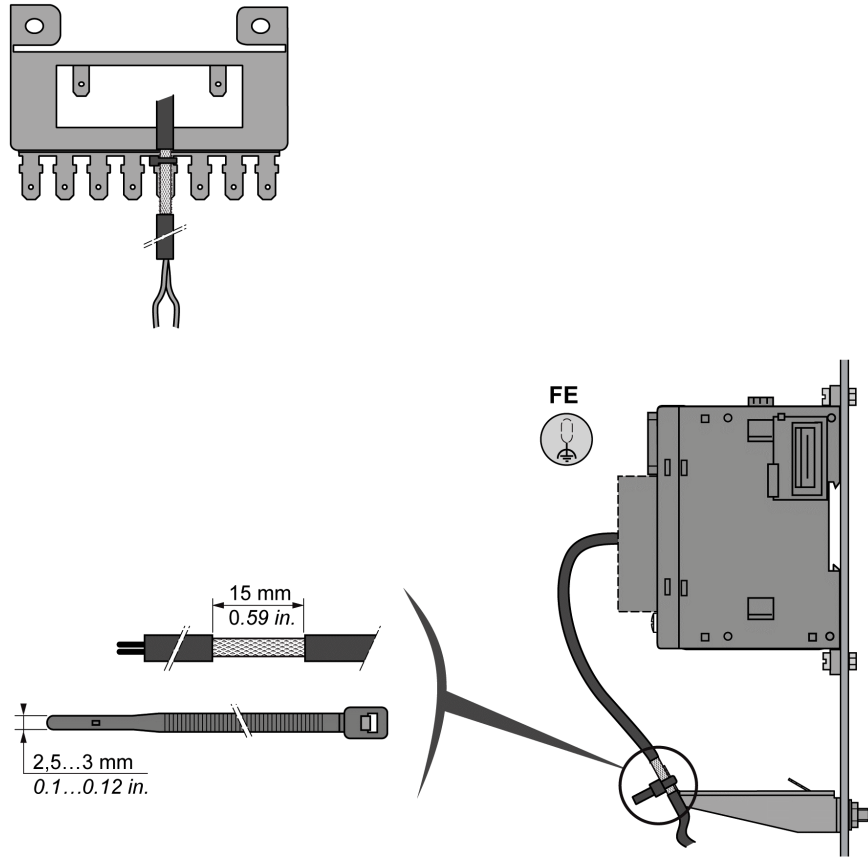

NOTE: The power supply wiring must be kept as short as possible.

TM3 Expert Expansion Modules

What's in This Part

TM3XTYS4 TeSys Module	39
TM3XFHSC202 / TM3XFHSC202G Module	47
TM3XHSC202 / TM3XHSC202G Module	54

TM3XTYS4 TeSys Module

What's in This Chapter

TM3XTYS4 Presentation 39
 TM3XTYS4 Characteristics 43
 TM3XTYS4 Wiring Diagram 45

Overview

This chapter describes the TM3XTYS4 module, its characteristics, and its connection to the different devices.

TM3XTYS4 Presentation

Overview

TM3XTYS4 TeSys module:

- 4 channels, each with
 - 3 sink inputs
 - 2 source transistor outputs
- Removable 24 Vdc power supply terminal block

Main Characteristics

Characteristics		Value
Input		Input 1: Ready Input 2: Run Input 3: Trip
Input type		24 Vdc Type 1 (IEC/EN 61131-2)
Logic type		Sink
Output		Output 1: Direction 1 control Output 2: Direction 2 control
Output type		24 Vdc / 0.3 A
Logic type		Source
Cable types and weight		
Cable type and length	Type	Ethernet CAT 5E
	Length	Maximum 5 m (16.4 ft)
Weight		115 g (4 oz)

TM3XTYS4 System Architecture

The TM3XTYS4 module connects the controller to the parallel wiring system of TeSys U and/or TeSys D. This parallel wiring module provides the status and command information for each starter. One TM3XTYS4 module can manage up to 4 starters, reverse or forward, whatever they are TeSys D or TeSys U.

TM3XTYS4 module is compatible with:

- TeSys U system
- TeSys D system

TeSys U System Architecture Example

TeSys model U is an integrated modular power management system for motor starters. The system provides motor starter overload protection and control functions.

The complete TeSys model U parallel wiring system consists in:

- a power base
- a contactor
- a thermal overload protection device
- a control unit for controller-starters

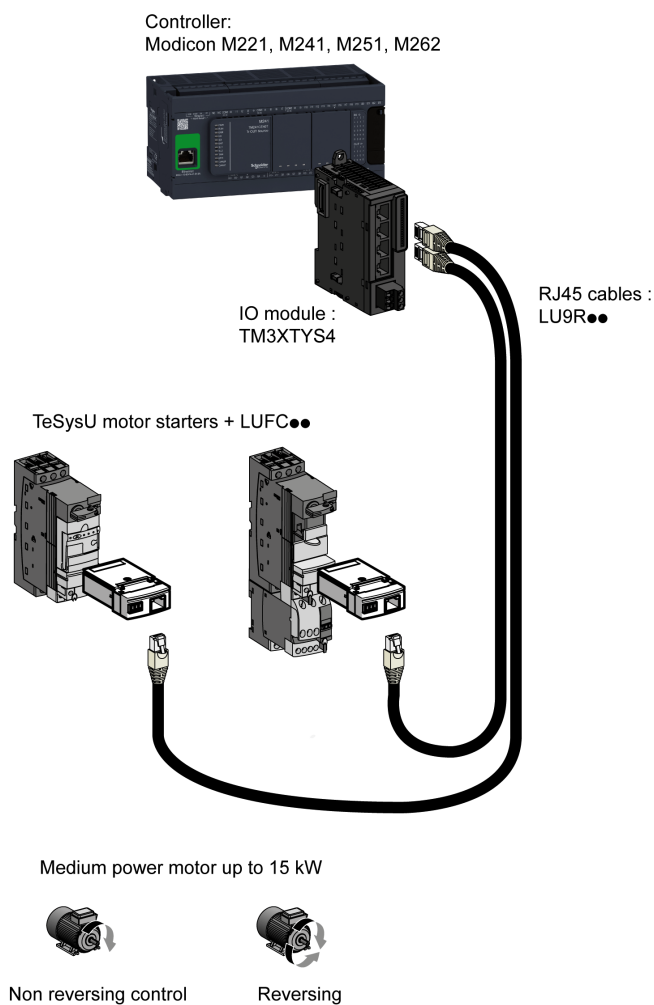

TeSys D System Architecture Example

TeSys model D is a motor control interface system for motor starters. The system provides motor starter overload protection and control functions.

The complete TeSys model D parallel wiring system consists in:

- a power base
- a contactor
- a thermal overload protection device
- a control unit for controller-starters

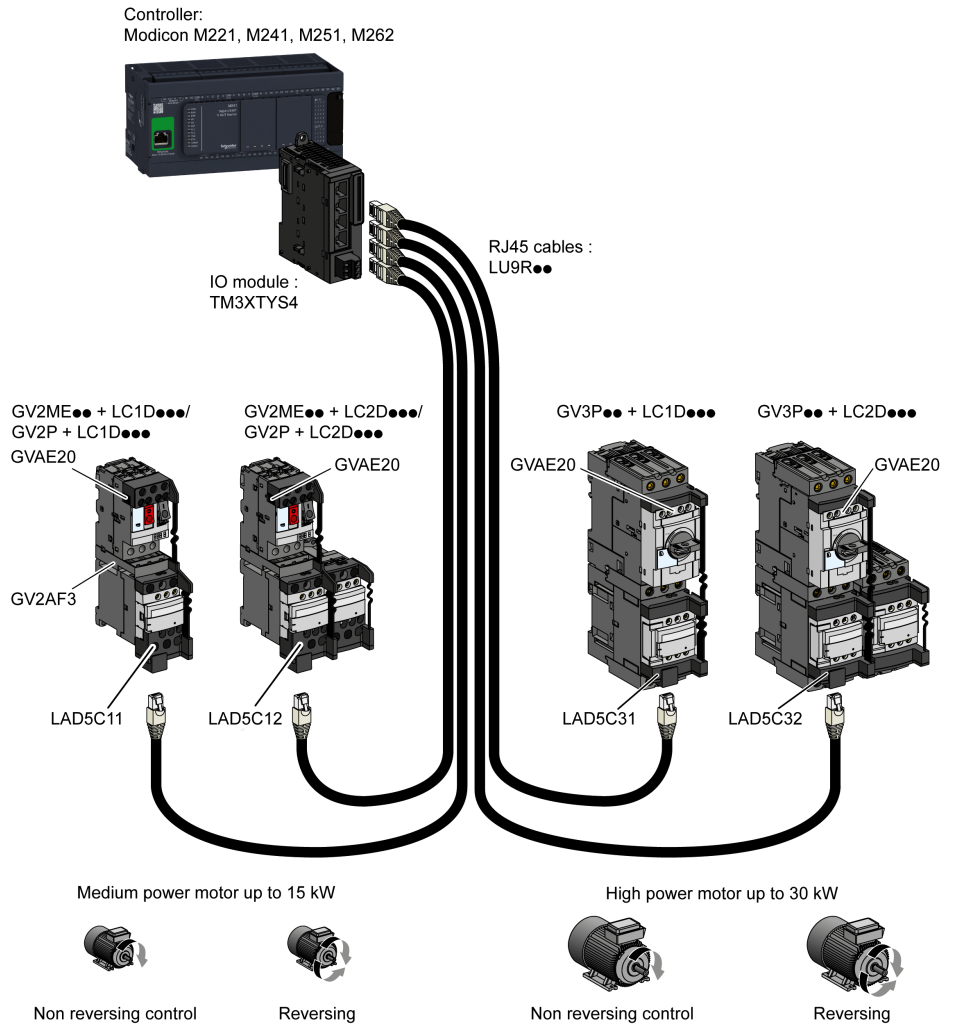

Status LEDs

The following figure shows the status LEDs:

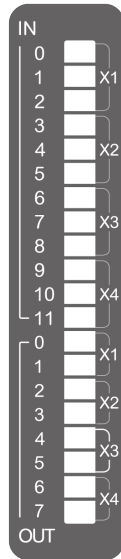

The following table describes the status LEDs:

LED	Color	Status	Type	Description
X1 (0...2)	Green	On	Input	The input channel is activated
		Off		The input channel is deactivated
X2 (3...5)		On		The input channel is activated
		Off		The input channel is deactivated
X3 (6...8)		On		The input channel is activated
		Off		The input channel is deactivated
X4 (9...11)		On		The input channel is activated
		Off		The input channel is deactivated
X1 (0, 1)		On	Output	The output channel is activated
		Off		The output channel is deactivated
X2 (2, 3)		On		The output channel is activated
		Off		The output channel is deactivated
X3 (4, 5)		On		The output channel is activated
		Off		The output channel is deactivated
X4 (6, 7)		On		The output channel is activated
		Off		The output channel is deactivated

TM3XTYS4 Characteristics

Introduction

This section provides a description of the electrical of the TM3XTYS4 module.

See also Environmental Characteristics, page 18.

▲ WARNING
UNINTENDED EQUIPMENT OPERATION
Do not exceed any of the rated values specified in the environmental and electrical characteristics tables.
Failure to follow these instructions can result in death, serious injury, or equipment damage.

Dimensions

The following diagrams show the dimensions for the TM3XTYS4 module:

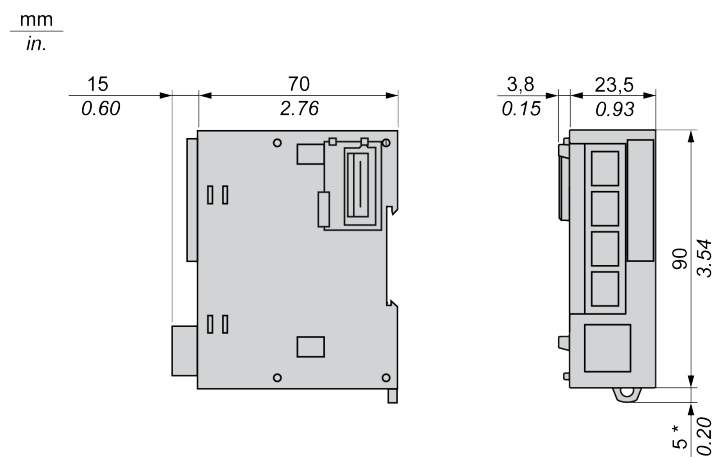

* 8.5 mm (0.33 in) when the clamp is pulled out.

Input/Output Characteristics

The following table describes the characteristics of one channel RJ45 connector:

Characteristic	Value	
Inputs	3 inputs <ul style="list-style-type: none"> Input 1: Ready Input 2: Run Input 3: Trip 	
Number of channels groups	1 common line for 3 inputs ⁽¹⁾	
Input type	Type 1 (IEC/EN 61131-2)	
Logic type	Sink	
Rated input voltage	24 Vdc	
Input voltage range	19.2...28.8 Vdc	
Rated input current	5 mA	
Turn on time	Typically 5 ms	
Turn off time	Typically 5 ms	
Outputs	2 outputs <ul style="list-style-type: none"> Output 1: Direction 1 control Output 2: Direction 2 control 	
Output type	Transistor	
Logic type	Source	
Rated input voltage	24 Vdc	
Output voltage range	19.2...28.8 Vdc	
Rated output current	300 mA per channel	
Voltage drop	Typically 0.15 Vdc (0.4 Vdc maximum)	
Leakage current when switched off	0.1 mA maximum	
Inductive load	L/R = 10 ms	
Turn on time	Typically 400 µs (450 µs maximum)	
Turn off time	Typically 400 µs (450 µs maximum)	
Protection against short circuit	Yes	
Clamping voltage	Typically 40 Vdc	
Module		
Isolation	Between input and internal logic	500 Vac
	Between output and internal logic	500 Vac
Connection type	RJ45 connector	
Connector insertion/removal durability	Over 100 times	
Current draw on 5 Vdc internal bus	37 mA (all inputs and outputs on)	
	17 mA (all inputs and outputs off)	
Current draw on 24 Vdc internal bus	17 mA (all inputs and outputs on)	
	0 mA (all inputs and outputs off)	
(1) The common line (pins 3) of the 4 RJ45 connectors are internally connected together. The 12 inputs of the module share the same common.		

TM3XTYS4 Wiring Diagram

Wiring Rules

See Wiring Best Practices, page 30.

I/O Channel RJ45 Connector

The TM3XTYS4 module is equipped with 4 channels RJ45 connector:

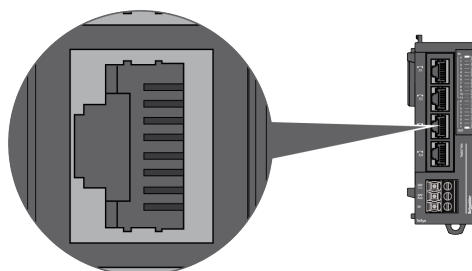

Pin Assignment

The following graphic and table show the channel RJ45 connector pin assignment:

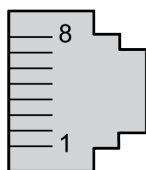

Pin N°	Designation	Signal	Description
1	Output 1	Direction 1 control	Drives the direct (forward) command of the motor.
2	Output 2	Direction 2 control	Drives the reverse (backward) command of the motor.
3	0 V	–	–
4	Input 1	Ready	Active if the selector of TeSys is in the ON position.
5	Input 2	Run	Input active if the power contacts of TeSys are closed.
6	N.C.	–	Reserved. Do not connect.
7	Input 3	Trip	Input active if the selector of TeSys is in the TRIP position (only for TeSys U).
8	24 Vdc input common	Common for sensors	Power supply for inputs 1, 2 and 3 (pins 4, 5 and 7).

⚠ WARNING

UNINTENDED EQUIPMENT OPERATION

Do not connect wires to unused terminals and/or terminals indicated as “No Connection (N.C.)”.

Failure to follow these instructions can result in death, serious injury, or equipment damage.

▲ CAUTION**INCOMPATIBLE EQUIPMENT**

Use the RJ45 connector only for the link with devices which are compatible with the TeSys RJ45 connection system.

Failure to follow these instructions can result in injury or equipment damage.

DC Power Supply Wiring Diagram

See DC Power Supply Characteristics, page 34.

TM3XFHSC202 / TM3XFHSC202G Module

What's in This Chapter

TM3XFHSC202 / TM3XFHSC202G Presentation47
 TM3XFHSC202 / TM3XFHSC202G Characteristics49
 TM3XFHSC202 / TM3XFHSC202G Wiring Diagram52

Overview

This chapter describes the TM3XFHSC202 / TM3XFHSC202G modules, their characteristics, and their connection to the different devices.

TM3XFHSC202 / TM3XFHSC202G Presentation

Overview

The TM3XFHSC202 (screw) and the TM3XFHSC202G (spring) are counting modules with event handling that are used for counting functions and position detection.

Main Characteristics

Characteristics	Value
Rated power supply voltage	24 Vdc
Voltage limit	20.4...28.8 Vdc
Current draw on 5 Vdc internal bus	Typically 65 mA at 25 °C (77 °F), maximum 110 mA
Current draw on 24 Vdc internal bus	Typically 30 mA at 25 °C (77 °F), maximum 50 mA
Isolation between input and internal logic	550 Vac for 1 min
Isolation between output and internal logic	
Connection type	TM3XFHSC202: Removable screw terminal block TM3XFHSC202G: Removable spring terminal block
Connector insertion/removal durability	Over 100 times
Weight	120 g without terminal block 150 g with terminal block

Compatibility

For information on the compatibility of these modules, refer to EcoStruxure Machine Expert Compatibility and Migration User Guide.

Architecture

The TM3 bus supports up to seven modules in the local configuration and up to seven modules in a remote configuration.

TM3XFHSC202 / TM3XFHSC202G modules support events if connected directly to an M262 controller or to another TM3XFHSC202 / TM3XFHSC202G.

That is to say, you can configure the events on the module if the module is the first TM3XFHSC202 / TM3XFHSC202G modules connected to the M262 controller, or is the second TM3XFHSC202 / TM3XFHSC202G module connected to the M262 controller given the first module is also a TM3XFHSC202 / TM3XFHSC202G module.

Module Status LEDs

The following table shows the module status LEDs:

RUN (Green)	ERR (Red)	Description
Off	Off	Module is not configured
Off	On	Module detected a system error
Fast flashing	Off	Module firmware is being updated
Operational		
On	Off	Module is configured and operational
	1 flash per second	Controller is RUNNING - 24Vdc outputs supply is off
	2 flashes per second	Controller is RUNNING - Short circuit on an output
	3 flashes per second	Controller is RUNNING - Event overflow
Regular flashing	1 flash per second	Controller is STOPPED - 24Vdc outputs supply is off
	2 flashes per second	Controller is STOPPED - Short circuit on an output
	3 flashes per second	Controller is STOPPED - Event overflow

Input/Output Status LEDs

The following table shows the input/output status LEDs:

Type	LED	Color	Status	Description
Input	0-9	Green	On	The input channel is activated.
			Off	The input channel is deactivated.
Output	0-7	Green	On	The output channel is activated.
			Off	The output channel is deactivated.

TM3XFHSC202 / TM3XFHSC202G Characteristics

Introduction

This section provides a description of the characteristics of the TM3XFHSC202 / TM3XFHSC202G modules. See also *Environmental Characteristics*, page 18.

▲ WARNING
UNINTENDED EQUIPMENT OPERATION
Do not exceed any of the rated values specified in the environmental and electrical characteristics tables.
Failure to follow these instructions can result in death, serious injury, or equipment damage.

Dimensions

The following diagram shows the dimensions of the TM3XFHSC202 / TM3XFHSC202G modules:

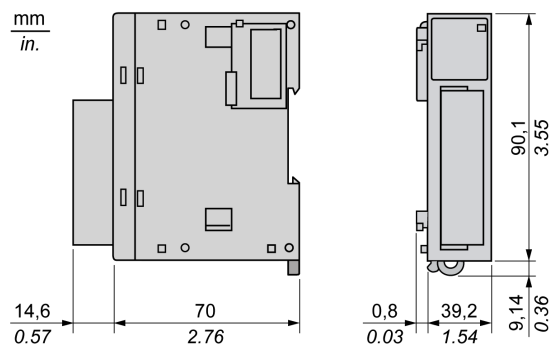

Input Characteristics

Characteristics		Value
Number		10
Number of channel groups		2 channel groups: 1 common line for I0 ...I4 1 common line for I5 ...I9
Input type		Type 1 (IEC 61131-2)
Logic type		Sink
Rated input voltage		24 Vdc
Input voltage limit		Maximum 30 Vdc
Rated input current		7.5 mA
Input impedance		2.81 kΩ
Input limit values	Voltage at state 1	> 15 Vdc (15...28.8 Vdc)
	Voltage at state 0	< 5 Vdc (0...5 Vdc)
	Current at state 1	> 3 mA
	Current at state 0	< 1.5 mA
Turn on time		< 1 μs + filter delay
Turn off time		< 1 μs + filter delay
Maximum input frequency		200 kHz
Isolation	Between input and internal logic	550 Vac for 1 minute
	Between input groups	None
	Between input channels	None
	Between inputs and outputs	550 Vac for 1 minute
Cable type		Shielded cable, including the COM signal Length: Maximum 10 m

Output Characteristics

Characteristics	Value
Number	8
Number of channel groups	2 channel groups: Q0...Q3 Q4...Q7
Output type	Transistor
Logic type	Source (push-pull)
Rated output voltage	24 Vdc
Rated output current	300 mA
Total rated output current per group	Maximum 1.2 A
Maximum power of filament lamp	Maximum 0.9 W
Leakage current	≤ 0.15 mA
Turn on time	Maximum 1 μs
Turn off time	Maximum 1 μs
Protection against short circuit or overload	Yes, typically 1 A per output Error managed by group: <ul style="list-style-type: none"> • Q0...Q3 • Q4...Q7
Automatic rearming after short circuit or overload	Yes, 10 s Enabled/Disabled by EcoStruxure Machine Expert
Clamping voltage	Typically 45 Vdc
Isolation	Between outputs and internal logic: 550 Vac for 1 minute
	Between output groups: none
	Between output channels: none
	Between outputs and inputs: 550 Vac for 1 minute
Cable length	< 30 m

Power Characteristics

Characteristics	Value
Type	PELV
Voltage nominal	24 Vdc
Voltage limits	20.4...28.8 Vdc with a maximum ripple of 10% of nominal voltage
Input current	Maximum 2.5 A
Inrush current	Not limited (except by overload peak current)
Voltage drop immunity	No
Reverse polarity protection	Yes
Overvoltage protection	No (external fuse required)
Power presence detection	Yes, threshold 15 V
Isolation	550 Vac for 1 minute with internal logic
Cable length	< 3 m

TM3XFHSC202 / TM3XFHSC202G Wiring Diagram

Introduction

The TM3XFHSC202 / TM3XFHSC202G are equipped with two removable screw or spring terminal blocks for the connection of inputs, outputs and 24 V power supply.

Wiring Rules

See Wiring Best Practices, page 30.

Wiring Diagram

The following diagram shows the wiring of the inputs:

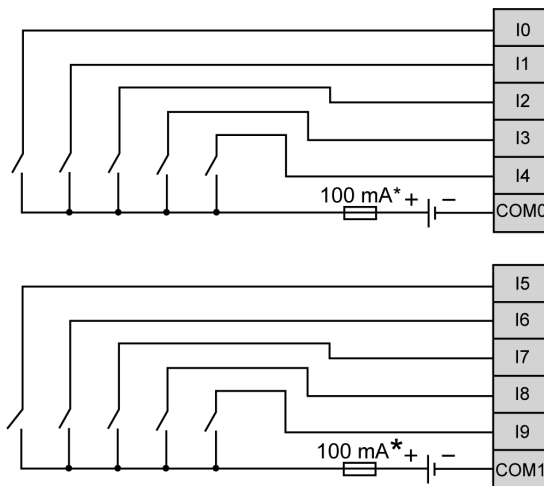

* Type T fuse

The following diagram shows the wiring outputs:

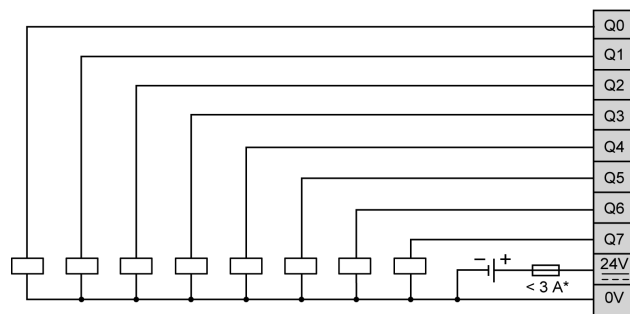

* Connect an appropriate type T fuse for the load, not to exceed 3 A.

Encoder Wiring

The following diagram shows the encoder wiring:

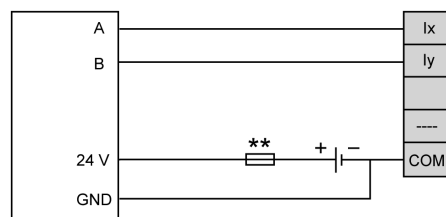

** Refer to the encoder documentation for fuse sizing.

NOTE: You must connect the output GND of the encoder to the COM terminal corresponding to the group of inputs which A and B are connected to:

- I0...I4: COM0
- I5...I9: COM1

TM3XHSC202 / TM3XHSC202G Module

What's in This Chapter

TM3XHSC202 / TM3XHSC202G Presentation	54
TM3XHSC202 / TM3XHSC202G Characteristics	55
TM3XHSC202 / TM3XHSC202G Wiring Diagram	58

Overview

This chapter describes the TM3XHSC202 / TM3XHSC202G modules, their characteristics, and their connection to the different devices.

TM3XHSC202 / TM3XHSC202G Presentation

Overview

The TM3XHSC202 (screw) and the TM3XHSC202G (spring) are counting modules that are used for counting functions and position detection.

Main Characteristics

Characteristics	Value
Rated power supply voltage	24 Vdc
Voltage limit	20.4...28.8 Vdc
Current draw on 5 Vdc internal bus	Typically 65 mA at 25 °C (77 °F), maximum 110 mA
Current draw on 24 Vdc internal bus	Typically 30 mA at 25 °C (77 °F), maximum 50 mA
Isolation between input and internal logic	550 Vac for 1 min
Isolation between output and internal logic	
Connection type	TM3XHSC202: Removable screw terminal block TM3XHSC202G: Removable spring terminal block
Connector insertion/removal durability	Over 100 times
Weight	120 g without terminal block 150 g with terminal block

Compatibility

For information on the compatibility of these modules, refer to EcoStruxure Machine Expert Compatibility and Migration User Guide.

Architecture

The TM3 bus supports up to seven modules in the local configuration and up to seven modules in a remote configuration.

Module Status LEDs

The following table shows the module status LEDs:

RUN (Green)	ERR (Red)	Description
Off	Off	Module is not configured
Off	On	Module detected a system error
Fast flashing	Off	Module firmware is being updated
Operational		
On	Off	Module is configured and operational
	1 flash per second	Controller is RUNNING - 24Vdc outputs supply is off
	2 flashes per second	Controller is RUNNING - Short circuit on an output
Regular flashing	1 flash per second	Controller is STOPPED - 24Vdc outputs supply is off
	2 flashes per second	Controller is STOPPED - Short circuit on an output

Input/Output Status LEDs

The following table shows the input/output status LEDs:

Type	LED	Color	Status	Description
Input	0-9	Green	On	The input channel is activated.
			Off	The input channel is deactivated.
Output	0-7	Green	On	The output channel is activated.
			Off	The output channel is deactivated.

TM3XHSC202 / TM3XHSC202G Characteristics

Introduction

This section provides a description of the characteristics of the TM3XHSC202 / TM3XHSC202G modules. See also [Environmental Characteristics](#), page 18.

▲ WARNING
UNINTENDED EQUIPMENT OPERATION
Do not exceed any of the rated values specified in the environmental and electrical characteristics tables.
Failure to follow these instructions can result in death, serious injury, or equipment damage.

Dimensions

The following diagram shows the dimensions of the TM3XHSC202 / TM3XHSC202G modules:

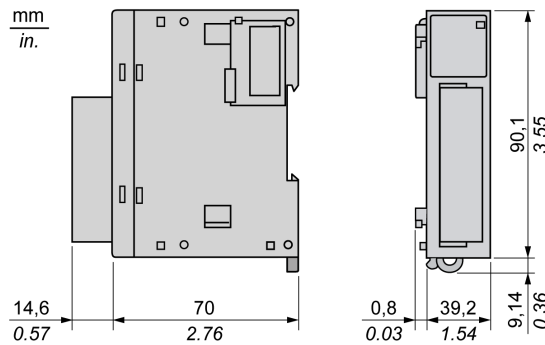

Input Characteristics

Characteristics		Value
Number		10
Number of channel groups		2 channel groups: 1 common line for I0 ...I4 1 common line for I5 ...I9
Input type		Type 1 (IEC 61131-2)
Logic type		Sink
Rated input voltage		24 Vdc
Input voltage limit		Maximum 30 Vdc
Rated input current		7.5 mA
Input impedance		2.81 kΩ
Input limit values	Voltage at state 1	> 15 Vdc (15...28.8 Vdc)
	Voltage at state 0	< 5 Vdc (0...5 Vdc)
	Current at state 1	> 3 mA
	Current at state 0	< 1.5 mA
Turn on time		< 1 μs + filter delay
Turn off time		< 1 μs + filter delay
Maximum input frequency		200 kHz
Isolation	Between input and internal logic	550 Vac for 1 minute
	Between input groups	None
	Between input channels	None
	Between inputs and outputs	550 Vac for 1 minute
Cable type		Shielded cable, including the COM signal Length: Maximum 10 m

Output Characteristics

Characteristics	Value
Number	8
Number of channel groups	2 channel groups: Q0...Q3 Q4...Q7
Output type	Transistor
Logic type	Source (push-pull)
Rated output voltage	24 Vdc
Rated output current	300 mA
Total rated output current per group	Maximum 1.2 A
Maximum power of filament lamp	Maximum 0.9 W
Leakage current	≤ 0.15 mA
Turn on time	Maximum 1 μs
Turn off time	Maximum 1 μs
Protection against short circuit or overload	Yes, typically 1 A per output Error managed by group: <ul style="list-style-type: none"> • Q0...Q3 • Q4...Q7
Automatic rearming after short circuit or overload	Yes, 10 s Enabled/Disabled by EcoStruxure Machine Expert
Clamping voltage	Typically 45 Vdc
Isolation	Between outputs and internal logic: 550 Vac for 1 minute
	Between output groups: none
	Between output channels: none
	Between outputs and inputs: 550 Vac for 1 minute
Cable length	< 30 m

Power Characteristics

Characteristics	Value
Type	PELV
Voltage nominal	24 Vdc
Voltage limits	20.4...28.8 Vdc with a maximum ripple of 10% of nominal voltage
Input current	Maximum 2.5 A
Inrush current	Not limited (except by overload peak current)
Voltage drop immunity	No
Reverse polarity protection	Yes
Overvoltage protection	No (external fuse required)
Power presence detection	Yes, threshold 15 V
Isolation	550 Vac for 1 minute with internal logic
Cable length	< 3 m

TM3XHSC202 / TM3XHSC202G Wiring Diagram

Introduction

The TM3XHSC202 / TM3XHSC202G are equipped with two removable screw or spring terminal blocks for the connection of inputs, outputs and 24 V power supply.

Wiring Rules

See Wiring Best Practices, page 30.

Wiring Diagram

The following diagram shows the wiring of the inputs:

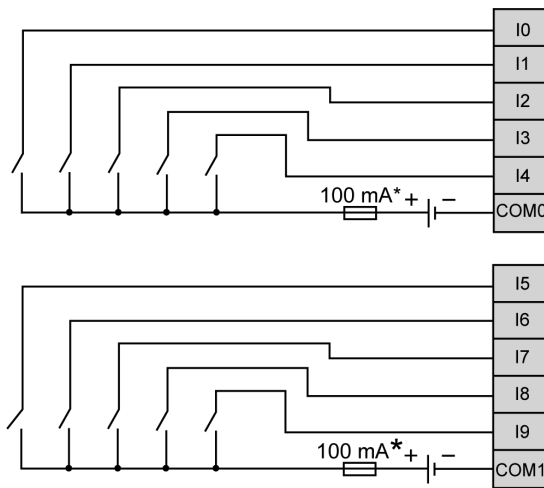

* Type T fuse

The following diagram shows the wiring of the outputs:

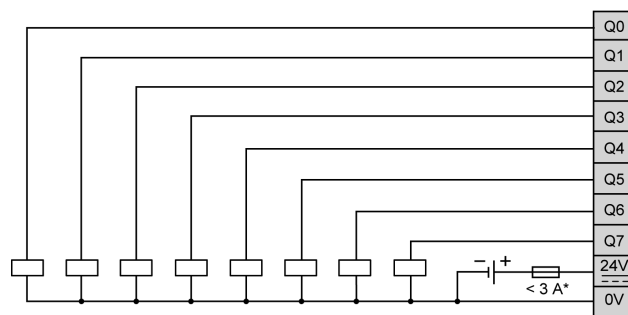

* Connect an appropriate type T fuse for the load, not to exceed 3 A.

Encoder Wiring

The following diagram shows the encoder wiring:

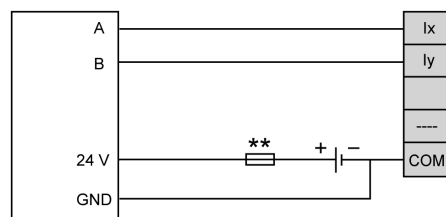

** Refer to the encoder documentation for fuse sizing.

NOTE: You must connect the output GND of the encoder to the COM terminal corresponding to the group of inputs which A and B are connected to:

- I0...I4: COM0
- I5...I9: COM1

Glossary

A

application:

A program including configuration data, symbols, and documentation.

C

controller:

Automates industrial processes (also known as programmable logic controller or programmable controller).

E

EIA rack:

(*electronic industries alliance rack*) A standardized (EIA 310-D, IEC 60297, and DIN 41494 SC48D) system for mounting various electronic modules in a stack or rack that is 19 inches (482.6 mm) wide.

EN:

EN identifies one of many European standards maintained by CEN (*European Committee for Standardization*), CENELEC (*European Committee for Electrotechnical Standardization*), or ETSI (*European Telecommunications Standards Institute*).

expansion bus:

An electronic communication bus between expansion I/O modules and a controller or bus coupler.

expansion connector:

A connector to attach expansion I/O modules.

H

HE10:

Rectangular connector for electrical signals with frequencies below 3 MHz, complying with IEC 60807-2.

I

IEC:

(*international electrotechnical commission*) A non-profit and non-governmental international standards organization that prepares and publishes international standards for electrical, electronic, and related technologies.

I/O:

(*input/output*)

IP 20:

(*ingress protection*) The protection classification according to IEC 60529 offered by an enclosure, shown by the letter IP and 2 digits. The first digit indicates 2 factors: helping protect persons and for equipment. The second digit indicates helping protect against water. IP 20 devices help protect against electric contact of objects larger than 12.5 mm, but not against water.

N

NEMA:

(national electrical manufacturers association) The standard for the performance of various classes of electrical enclosures. The NEMA standards cover corrosion resistance, ability to help protect from rain, submersion, and so on. For IEC member countries, the IEC 60529 standard classifies the ingress protection rating for enclosures.

P

program:

The component of an application that consists of compiled source code capable of being installed in the memory of a logic controller.

R

RJ45:

A standard type of 8-pin connector for network cables defined for Ethernet.

T

terminal block:

(terminal block) The component that mounts in an electronic module and provides electrical connections between the controller and the field devices.

Index

A

accessories	17
assembling to a controller	27

C

certifications and standards	20
characteristics	
TM3XFHSC202 / TM3XFHSC202G	49
TM3XHSC202 / TM3XHSC202G	55
TM3XTYS4	43
controllers	
disassembling a module	28

D

dimensions	
TM3XFHSC202 / TM3XFHSC202G	49
TM3XHSC202 / TM3XHSC202G	56
TM3XTYS4	43
DIN rail	25

E

electromagnetic susceptibility	20
environmental characteristics	18

G

grounding	35
-----------------	----

I

inductive load	33
intended use	6

M

minimum clearances	22
mounting position	22

O

output protection	33
-------------------------	----

P

physical description	
TM3X•HSC202•	16
TM3XTYS4	15
presentation	
TM3XFHSC202 / TM3XFHSC202G	47
TM3XHSC202 / TM3XHSC202G	54
TM3XTYS4	39

Q

qualification of personnel	5
----------------------------------	---

T

TM3X•HSC202•	
physical description	16
TM3XFHSC202 / TM3XFHSC202G	
characteristics	49
presentation	47
wiring diagram	52
TM3XHSC202 / TM3XHSC202G	
characteristics	55
presentation	54
wiring diagram	58
TM3XTYS4	
characteristics	43
physical description	15
presentation	39
wiring diagram	45

W

wiring diagram	
TM3XFHSC202 / TM3XFHSC202G	52
TM3XHSC202 / TM3XHSC202G	58
TM3XTYS4	45
wiring rules	30

Schneider Electric
35 rue Joseph Monier
92500 Rueil Malmaison
France

+ 33 (0) 1 41 29 70 00

www.se.com

As standards, specifications, and design change from time to time,
please ask for confirmation of the information given in this publication.

© 2024 Schneider Electric. All rights reserved.

EIO0000003137.04