

Modicon TM3

Analog I/O Modules

Hardware Guide

EIO0000003131.04

07/2024



Legal Information

The information provided in this document contains general descriptions, technical characteristics and/or recommendations related to products/solutions.

This document is not intended as a substitute for a detailed study or operational and site-specific development or schematic plan. It is not to be used for determining suitability or reliability of the products/solutions for specific user applications. It is the duty of any such user to perform or have any professional expert of its choice (integrator, specifier or the like) perform the appropriate and comprehensive risk analysis, evaluation and testing of the products/solutions with respect to the relevant specific application or use thereof.

The Schneider Electric brand and any trademarks of Schneider Electric SE and its subsidiaries referred to in this document are the property of Schneider Electric SE or its subsidiaries. All other brands may be trademarks of their respective owner.

This document and its content are protected under applicable copyright laws and provided for informative use only. No part of this document may be reproduced or transmitted in any form or by any means (electronic, mechanical, photocopying, recording, or otherwise), for any purpose, without the prior written permission of Schneider Electric.

Schneider Electric does not grant any right or license for commercial use of the document or its content, except for a non-exclusive and personal license to consult it on an "as is" basis.

Schneider Electric reserves the right to make changes or updates with respect to or in the content of this document or the format thereof, at any time without notice.

To the extent permitted by applicable law, no responsibility or liability is assumed by Schneider Electric and its subsidiaries for any errors or omissions in the informational content of this document, as well as any non-intended use or misuse of the content thereof.

Table of Contents

Safety Information	5
Qualification of Personnel	5
Intended Use	6
About the Book	7
TM3 Analog I/O Modules General Overview	13
TM3 Analog I/O Modules Description	14
General Description	14
Physical Description	18
Accessories	19
TM3 Analog I/O Modules Installation	20
TM3 Analog I/O Modules General Rules for Implementing	20
Environmental Characteristics	20
Certifications and Standards	22
TM3 Analog I/O Modules Installation	23
Installation and Maintenance Requirements	23
Installation Guidelines	24
Top Hat Section Rail (DIN rail)	26
Assembling a Module to a Controller or Receiver Module	27
Disassembling a Module from a Controller or Receiver Module	29
Direct Mounting on a Panel Surface	29
TM3 Analog I/O Modules Electrical Requirements	30
Wiring Best Practices	30
DC Power Supply Characteristics	33
Grounding the TM3 Analog I/O Modules	34
TM3 Analog Input Modules	37
TM3AI2H / TM3AI2HG Module 2 Inputs	38
TM3AI2H / TM3AI2HG Presentation	38
TM3AI2H / TM3AI2HG Characteristics	39
TM3AI2H / TM3AI2HG Wiring Diagram	42
TM3AI4 / TM3AI4G Module 4 Inputs	43
TM3AI4 / TM3AI4G Presentation	43
TM3AI4 / TM3AI4G Characteristics	44
TM3AI4 / TM3AI4G Wiring Diagram	47
TM3AI8 / TM3AI8G Module 8 Inputs	48
TM3AI8 / TM3AI8G Presentation	48
TM3AI8 / TM3AI8G Characteristics	49
TM3AI8 / TM3AI8G Wiring Diagram	52
TM3TI4 / TM3TI4G Module 4 Inputs	53
TM3TI4 / TM3TI4G Presentation	53
TM3TI4 / TM3TI4G Characteristics	54
TM3TI4 / TM3TI4G Wiring Diagram	58
TM3TI4D / TM3TI4DG Module 4 Inputs	59
TM3TI4D / TM3TI4DG Presentation	59
TM3TI4D / TM3TI4DG Characteristics	60
TM3TI4D / TM3TI4DG Wiring Diagram	64
TM3TI8T / TM3TI8TG Module 8 Inputs	65
TM3TI8T / TM3TI8TG Presentation	65

TM3TI8T / TM3TI8TG Characteristics	66
TM3TI8T / TM3TI8TG Wiring Diagram	70
TM3 Analog Output Modules	71
TM3AQ2 / TM3AQ2G Module 2 Outputs	72
TM3AQ2 / TM3AQ2G Presentation	72
TM3AQ2 / TM3AQ2G Characteristics	73
TM3AQ2 / TM3AQ2G Wiring Diagram	76
TM3AQ4 / TM3AQ4G Module 4 Outputs	77
TM3AQ4 / TM3AQ4G Presentation	77
TM3AQ4 / TM3AQ4G Characteristics	78
TM3AQ4 / TM3AQ4G Wiring Diagram	81
TM3 Analog Mixed Input/Output Modules	82
TM3AM6 / TM3AM6G Mixed I/O Module 4 Inputs/2 Outputs	83
TM3AM6 / TM3AM6G Presentation	83
TM3AM6 / TM3AM6G Characteristics	84
TM3AM6 / TM3AM6G Wiring Diagram	88
TM3TM3 / TM3TM3G Mixed I/O Module 2 Inputs/1 Output	89
TM3TM3 / TM3TM3G Presentation	89
TM3TM3 / TM3TM3G Characteristics	90
TM3TM3 / TM3TM3G Wiring Diagram	95
Glossary	97
Index	99

Safety Information

Important Information

Read these instructions carefully, and look at the equipment to become familiar with the device before trying to install, operate, service, or maintain it. The following special messages may appear throughout this documentation or on the equipment to warn of potential hazards or to call attention to information that clarifies or simplifies a procedure.



The addition of this symbol to a "Danger" or "Warning" safety label indicates that an electrical hazard exists which will result in personal injury if the instructions are not followed.



This is the safety alert symbol. It is used to alert you to potential personal injury hazards. Obey all safety messages that follow this symbol to avoid possible injury or death.

⚠ DANGER
DANGER indicates a hazardous situation which, if not avoided, will result in death or serious injury.

⚠ WARNING
WARNING indicates a hazardous situation which, if not avoided, could result in death or serious injury.

⚠ CAUTION
CAUTION indicates a hazardous situation which, if not avoided, could result in minor or moderate injury.

NOTICE
NOTICE is used to address practices not related to physical injury.

Please Note

Electrical equipment should be installed, operated, serviced, and maintained only by qualified personnel. No responsibility is assumed by Schneider Electric for any consequences arising out of the use of this material.

A qualified person is one who has skills and knowledge related to the construction and operation of electrical equipment and its installation, and has received safety training to recognize and avoid the hazards involved.

Qualification of Personnel

Only appropriately trained persons who are familiar with and understand the contents of this manual and all other pertinent product documentation are authorized to work on and with this product.

The qualified person must be able to detect possible hazards that may arise from parameterization, modifying parameter values and generally from mechanical, electrical, or electronic equipment. The qualified person must be familiar with the

standards, provisions, and regulations for the prevention of industrial accidents, which they must observe when designing and implementing the system.

Intended Use

The products described or affected by this document, together with software, accessories, and options, are expansion modules, intended for industrial use according to the instructions, directions, examples, and safety information contained in the present document and other supporting documentation.

The product may only be used in compliance with all applicable safety regulations and directives, the specified requirements, and the technical data.

Prior to using the product, you must perform a risk assessment in view of the planned application. Based on the results, the appropriate safety-related measures must be implemented.

Since the product is used as a component in an overall machine or process, you must ensure the safety of persons by means of the design of this overall system.

Operate the product only with the specified cables and accessories. Use only genuine accessories and spare parts.

Any use other than the use explicitly permitted is prohibited and can result in unanticipated hazards.

About the Book

Document Scope

This guide describes the hardware implementation of TM3 analog I/O expansion modules. It provides the description, characteristics, wiring diagrams, and installation details for TM3 analog I/O expansion modules.

Validity Note

This document has been updated for the release of EcoStruxure™ Machine Expert V2.2.

This document has been updated for the release of EcoStruxure™ Machine Expert - Basic V1.3.

For product compliance and environmental information (RoHS, REACH, PEP, EOL, etc.), go to www.se.com/ww/en/work/support/green-premium/.

The characteristics of the products described in this document are intended to match the characteristics that are available on www.se.com. As part of our corporate strategy for constant improvement, we may revise the content over time to enhance clarity and accuracy. If you see a difference between the characteristics in this document and the characteristics on www.se.com, consider www.se.com to contain the latest information.

Available Languages of this Document

This document is available in these languages:

- English (EIO0000003131)
- French (EIO0000003132)
- German (EIO0000003133)
- Spanish (EIO0000003134)
- Italian (EIO0000003135)
- Chinese (EIO0000003136)
- Portuguese (EIO0000003426)
- Turkish (EIO0000003427)

Related Documents

Title of Documentation	Reference Number
Modicon TM3 Expansion Modules - Programming Guide (EcoStruxure Machine Expert - Basic)	EIO0000003345 (ENG) EIO0000003346 (FRA) EIO0000003347 (GER) EIO0000003348 (SPA) EIO0000003349 (ITA) EIO0000003350 (CHS) EIO0000003351 (POR) EIO0000003352 (TUR)
Modicon TM3 Expansion Modules - Programming Guide (EcoStruxure Machine Expert)	EIO0000003119 (ENG) EIO0000003120 (FRA) EIO0000003121 (GER) EIO0000003122 (SPA) EIO0000003123 (ITA) EIO0000003124 (CHS)
Modicon M221 Logic Controller - Hardware Guide	EIO0000003313 (ENG) EIO0000003314 (FRA) EIO0000003315 (GER) EIO0000003316 (SPA) EIO0000003317 (ITA) EIO0000003318 (CHS) EIO0000003319 (POR) EIO0000003320 (TUR)
Modicon M241 Logic Controller - Hardware Guide	EIO0000003083 (ENG) EIO0000003084 (FRA) EIO0000003085 (GER) EIO0000003086 (SPA) EIO0000003087 (ITA) EIO0000003088 (CHS)
Modicon M251 Logic Controller - Hardware Guide	EIO0000003101 (ENG) EIO0000003102 (FRA) EIO0000003103 (GER) EIO0000003104 (SPA) EIO0000003105 (ITA) EIO0000003106 (CHS)

Title of Documentation	Reference Number
Modicon M262 Logic/Motion Controller - Hardware Guide	EIO0000003659 (ENG)
	EIO0000003660 (FRA)
	EIO0000003661 (GER)
	EIO0000003662 (SPA)
	EIO0000003663 (ITA)
	EIO0000003664 (CHS)
	EIO0000003665 (POR)
EIO0000003666 (TUR)	
TM3 Analog I/O Modules - Instruction Sheet	HRB59606

To find documents online, visit the Schneider Electric download center (www.se.com/ww/en/download/).

Product Related Information

⚠️ ⚠️ DANGER

HAZARD OF ELECTRIC SHOCK, EXPLOSION OR ARC FLASH

- Disconnect all power from all equipment including connected devices prior to removing any covers or doors, or installing or removing any accessories, hardware, cables, or wires except under the specific conditions specified in the appropriate hardware guide for this equipment.
- Always use a properly rated voltage sensing device to confirm the power is off where and when indicated.
- Replace and secure all covers, accessories, hardware, cables, and wires and confirm that a proper ground connection exists before applying power to the unit.
- Use only the specified voltage when operating this equipment and any associated products.

Failure to follow these instructions will result in death or serious injury.

⚠️ DANGER

POTENTIAL FOR EXPLOSION

- Only use this equipment in non-hazardous locations, or in locations that comply with Class I, Division 2, Groups A, B, C and D.
- Do not substitute components which would impair compliance to Class I, Division 2.
- Do not connect or disconnect equipment unless power has been removed or the location is known to be non-hazardous.
- Do not use the USB port(s), if so equipped, unless the location is known to be non-hazardous.

Failure to follow these instructions will result in death or serious injury.

⚠ WARNING**LOSS OF CONTROL**

- Perform a Failure Mode and Effects Analysis (FMEA), or equivalent risk analysis, of your application, and apply preventive and detective controls before implementation.
- Provide a fallback state for undesired control events or sequences.
- Provide separate or redundant control paths wherever required.
- Supply appropriate parameters, particularly for limits.
- Review the implications of transmission delays and take actions to mitigate them.
- Review the implications of communication link interruptions and take actions to mitigate them.
- Provide independent paths for control functions (for example, emergency stop, over-limit conditions, and error conditions) according to your risk assessment, and applicable codes and regulations.
- Apply local accident prevention and safety regulations and guidelines.¹
- Test each implementation of a system for proper operation before placing it into service.

Failure to follow these instructions can result in death, serious injury, or equipment damage.

¹ For additional information, refer to NEMA ICS 1.1 (latest edition), *Safety Guidelines for the Application, Installation, and Maintenance of Solid State Control* and to NEMA ICS 7.1 (latest edition), *Safety Standards for Construction and Guide for Selection, Installation and Operation of Adjustable-Speed Drive Systems* or their equivalent governing your particular location.

⚠ WARNING**UNINTENDED EQUIPMENT OPERATION**

- Only use software approved by Schneider Electric for use with this equipment.
- Update your application program every time you change the physical hardware configuration.

Failure to follow these instructions can result in death, serious injury, or equipment damage.

Information on Non-Inclusive or Insensitive Terminology

As a responsible, inclusive company, Schneider Electric is constantly updating its communications and products that contain non-inclusive or insensitive terminology. However, despite these efforts, our content may still contain terms that are deemed inappropriate by some customers.

Terminology Derived from Standards

The technical terms, terminology, symbols and the corresponding descriptions in the information contained herein, or that appear in or on the products themselves, are generally derived from the terms or definitions of international standards.

In the area of functional safety systems, drives and general automation, this may include, but is not limited to, terms such as *safety*, *safety function*, *safe state*, *fault*, *fault reset*, *malfunction*, *failure*, *error*, *error message*, *dangerous*, etc.

Among others, these standards include:

Standard	Description
IEC 61131-2:2007	Programmable controllers, part 2: Equipment requirements and tests.
ISO 13849-1:2023	Safety of machinery: Safety related parts of control systems. General principles for design.
EN 61496-1:2020	Safety of machinery: Electro-sensitive protective equipment. Part 1: General requirements and tests.
ISO 12100:2010	Safety of machinery - General principles for design - Risk assessment and risk reduction
EN 60204-1:2006	Safety of machinery - Electrical equipment of machines - Part 1: General requirements
ISO 14119:2013	Safety of machinery - Interlocking devices associated with guards - Principles for design and selection
ISO 13850:2015	Safety of machinery - Emergency stop - Principles for design
IEC 62061:2021	Safety of machinery - Functional safety of safety-related electrical, electronic, and electronic programmable control systems
IEC 61508-1:2010	Functional safety of electrical/electronic/programmable electronic safety-related systems: General requirements.
IEC 61508-2:2010	Functional safety of electrical/electronic/programmable electronic safety-related systems: Requirements for electrical/electronic/programmable electronic safety-related systems.
IEC 61508-3:2010	Functional safety of electrical/electronic/programmable electronic safety-related systems: Software requirements.
IEC 61784-3:2021	Industrial communication networks - Profiles - Part 3: Functional safety fieldbuses - General rules and profile definitions.
2006/42/EC	Machinery Directive
2014/30/EU	Electromagnetic Compatibility Directive
2014/35/EU	Low Voltage Directive

In addition, terms used in the present document may tangentially be used as they are derived from other standards such as:

Standard	Description
IEC 60034 series	Rotating electrical machines
IEC 61800 series	Adjustable speed electrical power drive systems
IEC 61158 series	Digital data communications for measurement and control – Fieldbus for use in industrial control systems

Finally, the term *zone of operation* may be used in conjunction with the description of specific hazards, and is defined as it is for a *hazard zone* or *danger zone* in the *Machinery Directive (2006/42/EC)* and *ISO 12100:2010*.

NOTE: The aforementioned standards may or may not apply to the specific products cited in the present documentation. For more information concerning the individual standards applicable to the products described herein, see the characteristics tables for those product references.

TM3 Analog I/O Modules General Overview

What's in This Part

TM3 Analog I/O Modules Description.....	14
TM3 Analog I/O Modules Installation.....	20

TM3 Analog I/O Modules Description

What's in This Chapter

General Description.....	14
Physical Description	18
Accessories	19

General Description

Introduction

The range of TM3 analog I/O expansion modules includes:

- Input modules
- Output modules
- Mixed input/output modules

All TM3 analog I/O expansion modules are equipped with (depending on the reference):

- Removable screw terminal blocks
- Removable spring terminal blocks

TM3 Analog Input Modules

The following table shows the TM3 analog input expansion modules, with corresponding resolution, channel type, nominal voltage/current, and terminal type:

Reference	Resolution	Channels	Channel Type	Mode	Terminal Type / Pitch
TM3AI2H, page 38	16 bit, or 15 bit + sign	2	inputs	0...10 Vdc -10...+10 Vdc 0...20 mA 4...20 mA	Removable screw terminal block / 5.08 mm
TM3AI2HG, page 38	16 bit, or 15 bit + sign	2	inputs	0...10 Vdc -10...+10 Vdc 0...20 mA 4...20 mA	Removable spring terminal block / 5.08 mm
TM3AI4, page 43	12 bit, or 11 bit + sign	4	inputs	0...10 Vdc -10...+10 Vdc 0...20 mA 4...20 mA	Removable screw terminal block / 3.81 mm
TM3AI4G, page 43	12 bit, or 11 bit + sign	4	inputs	0...10 Vdc -10...+10 Vdc 0...20 mA 4...20 mA	Removable spring terminal blocks / 3.81 mm
TM3AI8, page 48	12 bit, or 11 bit + sign	8	inputs	0...10 Vdc -10...+10 Vdc 0...20 mA 4...20 mA 0...20 mA extended 4...20 mA extended	Removable screw terminal block / 3.81 mm
TM3AI8G, page 48	12 bit, or 11 bit + sign	8	inputs	0...10 Vdc -10...+10 Vdc 0...20 mA 4...20 mA 0...20 mA extended 4...20 mA extended	Removable spring terminal blocks / 3.81 mm
TM3TI4, page 53	16 bit, or 15 bit + sign	4	inputs	0...10 Vdc -10...+10 Vdc 0...20 mA 4...20 mA Thermocouple PT100/1000 NI100/1000	Removable screw terminal block / 3.81 mm

Reference	Resolution	Channels	Channel Type	Mode	Terminal Type / Pitch
TM3TI4G, page 53	16 bit, or 15 bit + sign	4	inputs	0...10 Vdc -10...+10 Vdc 0...20 mA 4...20 mA Thermocouple PT100/1000 NI100/1000	Removable spring terminal blocks / 3.81 mm
TM3TI4D, page 59	16 bit, or 15 bit + sign	4	inputs	Thermocouple	Removable screw terminal block / 3.81 mm
TM3TI4DG, page 59	16 bit, or 15 bit + sign	4	inputs	Thermocouple	Removable spring terminal blocks / 3.81 mm
TM3TI8T, page 65	16 bit, or 15 bit + sign	8	inputs	Thermocouple NTC/PTC Ohmmeter	Removable screw terminal block / 3.81 mm
TM3TI8TG, page 65	16 bit, or 15 bit + sign	8	inputs	Thermocouple NTC/PTC Ohmmeter	Removable spring terminal blocks / 3.81 mm

TM3 Analog Output Modules

The following table shows the TM3 analog output modules, with corresponding resolution, channel type, nominal voltage/current, and terminal type:

Reference	Resolution	Channels	Channel Type	Mode	Terminal Type / Pitch
TM3AQ2, page 72	12 bit, or 11 bit + sign	2	outputs	0...10 Vdc -10...+10 Vdc 0...20 mA 4...20 mA	Removable screw terminal block / 5.08 mm
TM3AQ2G, page 72	12 bit, or 11 bit + sign	2	outputs	0...10 Vdc -10...+10 Vdc 0...20 mA 4...20 mA	Removable spring terminal block / 5.08 mm
TM3AQ4, page 77	12 bit, or 11 bit + sign	4	outputs	0...10 Vdc -10...+10 Vdc 0...20 mA 4...20 mA	Removable screw terminal block / 5.08 mm
TM3AQ4G, page 77	12 bit, or 11 bit + sign	4	outputs	0...10 Vdc -10...+10 Vdc 0...20 mA 4...20 mA	Removable spring terminal block / 5.08 mm

TM3 Analog Mixed Input/Output Modules

This following table shows the TM3 analog mixed I/O modules, with corresponding resolution, channel type, nominal voltage/current, and terminal type:

Reference	Resolution	Channels	Channel Type	Mode	Terminal Type / Pitch
TM3AM6, page 83	12 bit, or 11 bit + sign	4	inputs	0...10 Vdc	Removable screw terminal block / 3.81 mm
		2	outputs	-10...+10 Vdc 0...20 mA 4...20 mA	
TM3AM6G, page 83	12 bit, or 11 bit + sign	4	inputs	0...10 Vdc	Removable spring terminal block / 3.81 mm
		2	outputs	-10...+10 Vdc 0...20 mA 4...20 mA	
TM3TM3, page 89	16 bit, or 15 bit + sign	2	inputs	0...10 Vdc -10...+10 Vdc 0...20 mA 4...20 mA Thermocouple PT100/1000 NI100/1000	Removable screw terminal block / 5.08 mm
	12 bit, or 11 bit + sign	1	outputs	0...10 Vdc -10...+10 Vdc 0...20 mA 4...20 mA	
TM3TM3G, page 89	16 bit, or 15 bit + sign	2	inputs	0...10 Vdc -10...+10 Vdc 0...20 mA 4...20 mA Thermocouple PT100/1000 NI100/1000	Removable spring terminal block / 5.08 mm
	12 bit, or 11 bit + sign	1	outputs	0...10 Vdc -10...+10 Vdc 0...20 mA 4...20 mA	

Physical Description

Introduction

This section describes the physical characteristics of the TM3 analog expansion modules. The modules, depending on the reference, support removable screw or spring terminal block.

TM3 Analog I/O Modules with Removable Screw or Spring Terminal Block

The following figure shows the main elements of TM3 analog expansion modules with removable screw or spring terminal block:

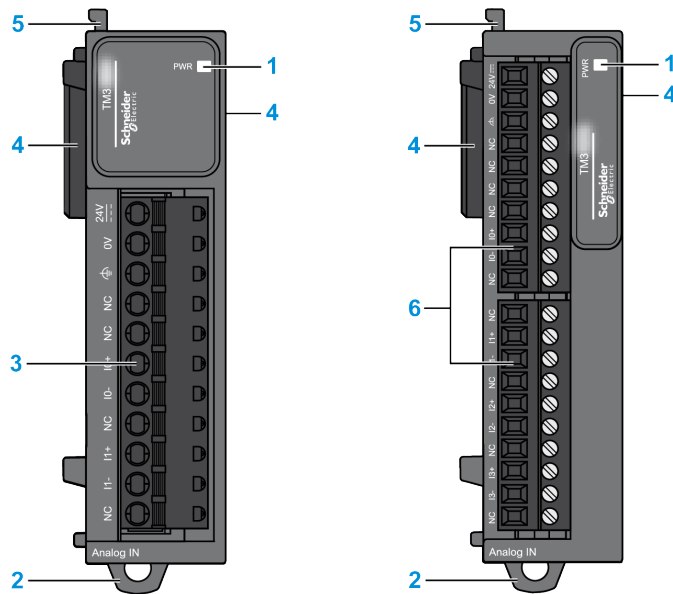

This table describes the main elements of the TM3 expansion modules shown above:

N°	Description	Refer to
1	Power supply LED	–
2	Clip-on lock for 35 mm (1.38 in.) top hat section rail (DIN-rail)	Top Hat Section Rail (DIN rail), page 26
3	Removable terminal block (spring)	Rules for Removable Spring Terminal Block, page 33
4	Expansion connector for TM3 I/O bus (one on each side)	–
5	Locking device for attachment to the previous module	–
6	Removable terminal block (screw)	Rules for Removable Screw Terminal Block, page 32

Accessories

Overview

This section describes the accessories.

Accessories

Reference	Description	Use	Quantity
TMAT2MSET	Set of 8 removable screw terminal blocks: <ul style="list-style-type: none"> • 4 x Removable screw terminal blocks (pitch 3.81 mm) with 11 terminals for inputs/outputs • 4 x Removable screw terminal blocks (pitch 3.81 mm) with 10 terminals for inputs/outputs 	Connects the module I/Os.	1
TMAT2MSETG	Set of 8 removable spring terminal blocks: <ul style="list-style-type: none"> • 4 x Removable spring terminal blocks (pitch 3.81 mm) with 11 terminals for inputs/outputs • 4 x Removable spring terminal blocks (pitch 3.81 mm) with 10 terminals for inputs/outputs 		
NSYTRAAB35	End brackets	Help secure the logic controller or receiver module and their expansion modules on a top hat section rail (DIN rail).	
TMAM2	Mounting kit	Mounts the controller and I/O modules directly to a flat, vertical panel.	
TM200RSRCEMC	Shielding take-up clip	Mounts and connects the ground to the cable shielding.	25-pack

For top hat section rails (DIN rails), refer to Top Hat Section Rail (DIN rail), page 26.

TM3 Analog I/O Modules Installation

What's in This Chapter

TM3 Analog I/O Modules General Rules for Implementing 20
 TM3 Analog I/O Modules Installation 23
 TM3 Analog I/O Modules Electrical Requirements 30

TM3 Analog I/O Modules General Rules for Implementing

Environmental Characteristics

Enclosure Requirements

TM3 expansion module components are designed as Zone B, Class A industrial equipment according to IEC/CISPR Publication 11. If they are used in environments other than those described in these standards, or in environments that do not meet the specifications in this manual the ability to meet electromagnetic compatibility requirements in the presence of conducted and/or radiated interference may be reduced.

All TM3 expansion module components meet European Community (CE) requirements for open equipment as defined by IEC/EN 61131-2. You must install them in an enclosure designed for the specific environmental conditions and to minimize the possibility of unintended contact with hazardous voltages. Use metal enclosures to improve the electromagnetic immunity of your TM3 expansion module components. Use enclosures with a keyed locking mechanism to minimize unauthorized access.

Environmental Characteristics

All the TM3 expansion module components are electrically isolated between the internal electronic circuit and the input/output channels. This equipment meets CE requirements as indicated in the table below. This equipment is intended for use in a Pollution Degree 2 industrial environment.

⚠ WARNING
UNINTENDED EQUIPMENT OPERATION
Do not exceed any of the rated values specified in the environmental and electrical characteristics tables.
Failure to follow these instructions can result in death, serious injury, or equipment damage.

The following table shows the general environmental characteristics:

Characteristic	Minimum Specification	Tested Range	
Standard compliance	IEC/EN 61131-2	–	
Ambient operating temperature	–	Horizontal installation	-10...55 °C (14...131 °F)
	–	Vertical installation	-10...35 °C (14...95 °F)
Storage temperature	–	-25...70 °C (-13...158 °F)	
Relative humidity	–	Transport and storage	10...95 % (non-condensing)
		Operation	10...95 % (non-condensing)
Degree of pollution	IEC/EN 60664-1	2	
Degree of protection	IEC/EN 61131-2	IP20	
Corrosion immunity	–	Atmosphere free from corrosive gases	
Operating altitude	–	0...2000 m (0...6560 ft)	
Storage altitude	–	0...3000 m (0...9843 ft)	
Vibration resistance	IEC/EN 61131-2	Panel mounting or mounted on a top hat section rail (DIN rail)	10 mm (0.39 in) fixed amplitude from 5...8.7 Hz 29.4 m/s ² (96.45 ft/s ²) (3 g _n) fixed acceleration from 8.7...150 Hz
Mechanical shock resistance	–	147 m/s ² or 482.28 ft/s ² (15 g _n) for a duration of 11 ms	
<p>NOTE: The tested ranges may indicate values beyond that of the IEC Standard. However, our internal standards define what is necessary for industrial environments. In all cases, we uphold the minimum specification if indicated.</p>			

Electromagnetic Susceptibility

The TM3 expansion module components meets electromagnetic susceptibility specifications as indicated in the following table:

Characteristic	Minimum Specification	Tested Range		
Electrostatic discharge	IEC/EN 61000-4-2	8 kV (air discharge) 4 kV (contact discharge)		
Radiated electromagnetic field	IEC/EN 61000-4-3	10 V/m (80...1000 MHz) 3 V/m (1.4...2 GHz) 1 V/m (2...3 GHz)		
Magnetic field	IEC/EN 61000-4-8	30 A/m 50 Hz, 60 Hz		
Fast transients burst	IEC/EN 61000-4-4	–	CM ¹ and DM ²	
		AC/DC Power lines	–	
		Relay Outputs	–	
		24 Vdc I/Os	–	
		Analog I/Os	1 kV	
		Communication line	–	
Surge immunity	IEC/EN 61000-4-5 IEC/EN 61131-2	–	CM ¹	DM ²
		DC Power lines	1 kV	0.5 kV
		AC Power lines	–	–
		Relay Outputs	–	–
		24 Vdc I/Os	1 kV	–
		Shielded cable (between shield and ground)	1 kV	–
Induced electromagnetic field	IEC/EN 61000-4-6	10 Vrms (0.15...80 MHz)		
Conducted emission	IEC 61000-6-4	AC power line:		
		<ul style="list-style-type: none"> 0.15...0.5 MHz: 79 dBμV/m QP / 66 dBμV/m AV 0.5...300 MHz: 73 dBμV/m QP / 60 dBμV/m AV 		
Radiated emission	IEC 61000-6-4	AC/DC power line:		
		<ul style="list-style-type: none"> 10...150 kHz: 120...69 dBμV/m QP 150...1500 kHz: 79...63 dBμV/m QP 1.5...30 MHz: 63 dBμV/m QP 		
Radiated emission	IEC 61000-6-4	30...230 MHz: 40 dB μ V/m QP 230...1000 MHz: 47 dB μ V/m QP		
1 Common Mode 2 Differential Mode NOTE: The tested ranges may indicate values beyond that of the IEC Standard. However, our internal standards define what is necessary for industrial environments. In all cases, we uphold the minimum specification if indicated.				

Certifications and Standards

Introduction

For information on certifications and conformance to standards, go to www.se.com.

For product compliance and environmental information (RoHS, REACH, PEP, EOL, etc.), go to www.se.com/green-premium.

TM3 Analog I/O Modules Installation

Installation and Maintenance Requirements

Before Starting

Read and understand this chapter before beginning the installation of your system.

The use and application of the information contained herein require expertise in the design and programming of automated control systems. Only you, the user, machine builder or integrator, can be aware of all the conditions and factors present during installation and setup, operation, and maintenance of the machine or process, and can therefore determine the automation and associated equipment and the related safeties and interlocks which can be effectively and properly used. When selecting automation and control equipment, and any other related equipment or software, for a particular application, you must also consider any applicable local, regional or national standards and/or regulations.

Pay particular attention in conforming to any safety information, different electrical requirements, and normative standards that would apply to your machine or process in the use of this equipment.

Disconnecting Power

All options and modules should be assembled and installed before installing the control system on a mounting rail, onto a mounting plate or in a panel. Remove the control system from its mounting rail, mounting plate or panel before disassembling the equipment.

⚠️⚠️ DANGER
HAZARD OF ELECTRIC SHOCK, EXPLOSION OR ARC FLASH
<ul style="list-style-type: none"> • Disconnect all power from all equipment including connected devices prior to removing any covers or doors, or installing or removing any accessories, hardware, cables, or wires except under the specific conditions specified in the appropriate hardware guide for this equipment. • Always use a properly rated voltage sensing device to confirm the power is off where and when indicated. • Replace and secure all covers, accessories, hardware, cables, and wires and confirm that a proper ground connection exists before applying power to the unit. • Use only the specified voltage when operating this equipment and any associated products.
Failure to follow these instructions will result in death or serious injury.

Programming Considerations

⚠️ WARNING
UNINTENDED EQUIPMENT OPERATION
<ul style="list-style-type: none"> • Only use software approved by Schneider Electric for use with this equipment. • Update your application program every time you change the physical hardware configuration.
Failure to follow these instructions can result in death, serious injury, or equipment damage.

Operating Environment

In addition to the **Environmental Characteristics**, refer to **Product Related Information** in the beginning of the present document for important information regarding installation in hazardous locations for this specific equipment.

⚠ WARNING

UNINTENDED EQUIPMENT OPERATION

Install and operate this equipment according to the conditions described in the Environmental Characteristics.

Failure to follow these instructions can result in death, serious injury, or equipment damage.

Installation Considerations

⚠ WARNING

UNINTENDED EQUIPMENT OPERATION

- Use appropriate safety interlocks where personnel and/or equipment hazards exist.
- Install and operate this equipment in an enclosure appropriately rated for its intended environment and secured by a keyed or tooled locking mechanism.
- Use the sensor and actuator power supplies only for supplying power to the sensors or actuators connected to the module.
- Power line and output circuits must be wired and fused in compliance with local and national regulatory requirements for the rated current and voltage of the particular equipment.
- Do not use this equipment in safety-critical machine functions unless the equipment is otherwise designated as functional safety equipment and conforming to applicable regulations and standards.
- Do not disassemble, repair, or modify this equipment.
- Do not connect any wiring to reserved, unused connections, or to connections designated as No Connection (N.C.).

Failure to follow these instructions can result in death, serious injury, or equipment damage.

NOTE: JDYX2 or JDYX8 fuse types are cULus-recognized.

Installation Guidelines

Introduction

TM3 expansion modules are assembled by connecting them to a logic controller or receiver module.

The logic controller or receiver module and their expansion modules can be installed on a top hat section rail (DIN rail).

Mounting Position and Minimum Clearances

The mounting position and minimum clearances of the expansion modules must conform with the rules defined for the appropriate hardware system. Refer to the *Installation chapter* in the *Controller Hardware* documentation for your specific controller.

▲ WARNING

UNINTENDED EQUIPMENT OPERATION

- Place devices dissipating the most heat at the top of the cabinet and ensure adequate ventilation.
- Avoid placing this equipment next to or above devices that might cause overheating.
- Install the equipment in a location providing the minimum clearances from all adjacent structures and equipment as directed in this document.
- Install all equipment in accordance with the specifications in the related documentation.

Failure to follow these instructions can result in death, serious injury, or equipment damage.

Correct Mounting Position

To obtain optimal operating characteristics, the TM3 Analog I/O Modules should be mounted horizontally on a vertical plane as shown in the figure below:

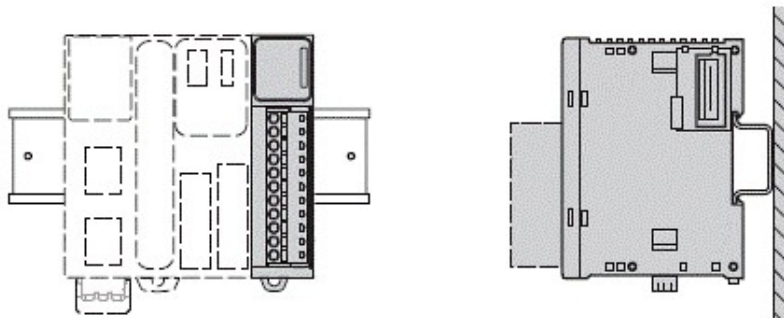

Acceptable Mounting Position

The TM3 Analog I/O Modules can also be mounted vertically on a vertical plane as shown below:

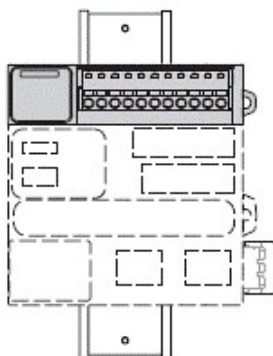

Incorrect Mounting Positions

The TM3 Analog I/O Modules should only be positioned as shown in the *Correct Mounting Position*, page 25 figure. The figures below show the incorrect mounting positions:

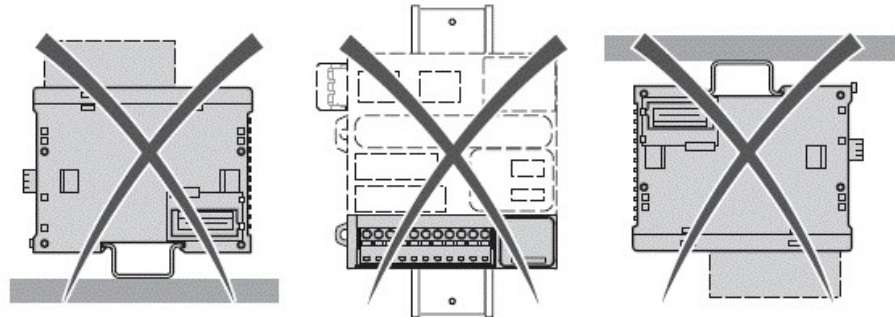

Top Hat Section Rail (DIN rail)

Dimensions of Top Hat Section Rail DIN Rail

You can mount the controller or receiver and their expansions on a 35 mm (1.38 in.) top hat section rail (DIN rail). The DIN rail can be attached to a smooth mounting surface or suspended from an EIA rack or mounted in a NEMA cabinet.

Symmetric Top Hat Section Rails (DIN Rail)

The following illustration and table indicate the references of the top hat section rails (DIN rail) for the wall-mounting range:

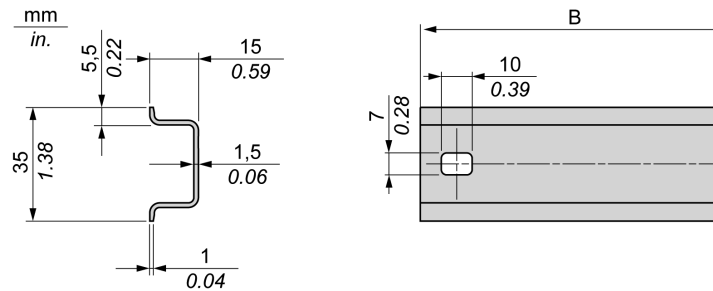

Reference	Type	Perforated	Rail Length (B)
NSYSDR50A	A	At each end	450 mm (17.71 in.)
NSYSDR60A	A	At each end	550 mm (21.65 in.)
NSYSDR80A	A	At each end	750 mm (29.52 in.)
NSYSDR100A	A	At each end	950 mm (37.40 in.)

The following illustration and table indicate the references of the symmetric top hat section rails (DIN rail) of 2000 mm (78.74 in.):

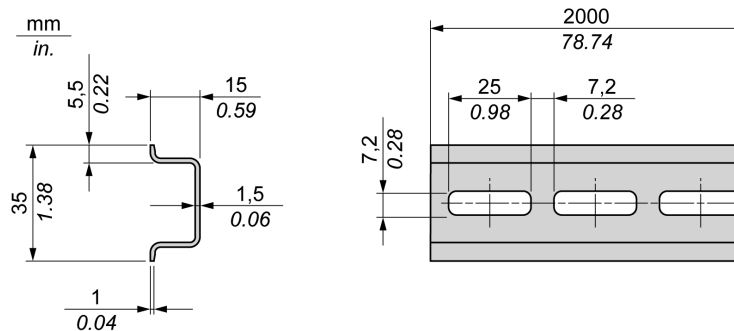

Reference	Type	Perforated	Rail Length
NSYSDR200	A	No	2000 mm (78.74 in.)
NSYSDR200D	A	Yes	

Double-Profile Top Hat Section Rails (DIN rail)

The following illustration and table indicate the references of the double-profile top hat section rails (DIN rail) of 2000 mm (78.74 in.):

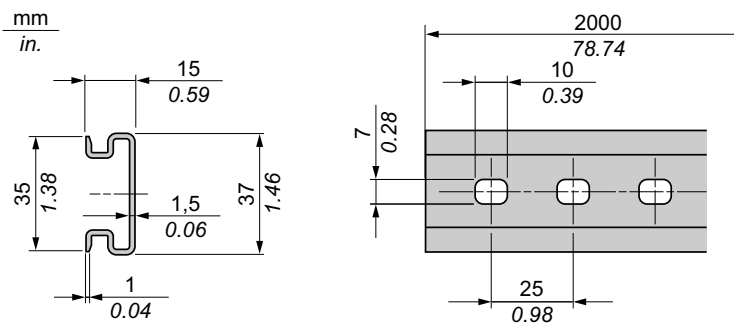

Reference	Type	Perforated	Rail Length
NSYDPR200	-	No	2000 mm (78.74 in.)
NSYDPR200D	-	Yes	

Assembling a Module to a Controller or Receiver Module

Introduction

This section describes how to assemble an expansion module to a controller, receiver module or other modules.

⚡⚠ DANGER

HAZARD OF ELECTRIC SHOCK, EXPLOSION OR ARC FLASH

- Disconnect all power from all equipment including connected devices prior to removing any covers or doors, or installing or removing any accessories, hardware, cables, or wires except under the specific conditions specified in the appropriate hardware guide for this equipment.
- Always use a properly rated voltage sensing device to confirm the power is off where and when indicated.
- Replace and secure all covers, accessories, hardware, cables, and wires and confirm that a proper ground connection exists before applying power to the unit.
- Use only the specified voltage when operating this equipment and any associated products.

Failure to follow these instructions will result in death or serious injury.

After connecting new modules to the controller, either directly or through a transmitter/receiver, update and reupload your application program before placing the system back in service. If you do not revise your application program to reflect the addition of new modules, I/O located on the expansion bus may no longer operate normally.

⚠ WARNING

UNINTENDED EQUIPMENT OPERATION

- Only use software approved by Schneider Electric for use with this equipment.
- Update your application program every time you change the physical hardware configuration.

Failure to follow these instructions can result in death, serious injury, or equipment damage.

Assembling a Module to a Controller or Receiver Module

The following procedure shows how to assemble a controller or receiver module and a module together:

Step	Action
1	Remove all power and dismount any existing controller I/O assembly from its DIN mounting.
2	Remove the expansion connector sticker from the controller or the outermost installed expansion module.
3	Verify that the locking device, page 18 on the new module is in the upper position.
4	Align the internal bus connector on the left side of the module with the internal bus connector on the right side of the controller, receiver module or expansion module.
5	Press the new module towards the controller, receiver module or expansion module until it is securely in place.
6	Push down the locking device, page 18 on the top of the new module to lock it to the controller, receiver module or previously installed expansion module.

Disassembling a Module from a Controller or Receiver Module

Introduction

This section describes how to disassemble a module from a controller or receiver module.

⚠️⚠️ DANGER

HAZARD OF ELECTRIC SHOCK, EXPLOSION OR ARC FLASH

- Disconnect all power from all equipment including connected devices prior to removing any covers or doors, or installing or removing any accessories, hardware, cables, or wires except under the specific conditions specified in the appropriate hardware guide for this equipment.
- Always use a properly rated voltage sensing device to confirm the power is off where and when indicated.
- Replace and secure all covers, accessories, hardware, cables, and wires and confirm that a proper ground connection exists before applying power to the unit.
- Use only the specified voltage when operating this equipment and any associated products.

Failure to follow these instructions will result in death or serious injury.

Disassembling a Module from a Controller or Receiver Module

The following procedure describes how to disassemble a module from a controller or receiver module:

Step	Action
1	Remove all power from the control system.
2	Dismount the assembled controller and modules from the mounting rail.
3	Push up the locking device, page 18 from the bottom of the module to disengage it from the controller or the receiver module.
4	Pull apart the module from the controller or the receiver module.

Direct Mounting on a Panel Surface

Overview

This section shows how to install TM3 expansion module using the Panel Mounting Kit. This section also provides mounting hole layout for all modules.

Installing the Panel Mounting Kit

The following procedure shows how to install a mounting strip:

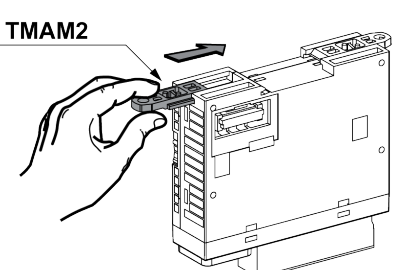
Step	Action
1	Insert the mounting strip TMAM2 into the slot at the top of the module. 

Mounting Hole Layout

The following diagram shows the mounting holes for TM3 with 2, 4 and 8 screw or spring I/O channels:

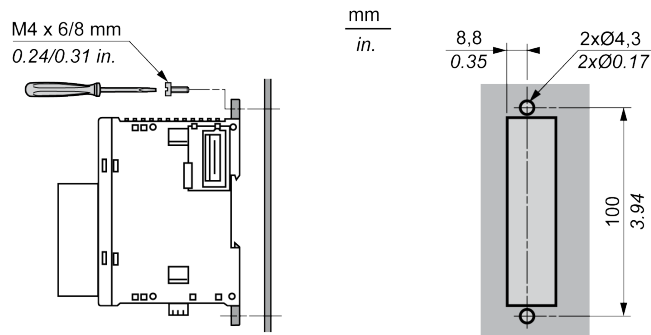

TM3 Analog I/O Modules Electrical Requirements

Wiring Best Practices

Overview

This section describes the wiring guidelines and associated best practices to be respected when using the TM3 system.

⚠️ DANGER**HAZARD OF ELECTRIC SHOCK, EXPLOSION OR ARC FLASH**

- Disconnect all power from all equipment including connected devices prior to removing any covers or doors, or installing or removing any accessories, hardware, cables, or wires except under the specific conditions specified in the appropriate hardware guide for this equipment.
- Always use a properly rated voltage sensing device to confirm the power is off where and when indicated.
- Replace and secure all covers, accessories, hardware, cables, and wires and confirm that a proper ground connection exists before applying power to the unit.
- Use only the specified voltage when operating this equipment and any associated products.

Failure to follow these instructions will result in death or serious injury.

⚠️ WARNING**LOSS OF CONTROL**

- Perform a Failure Mode and Effects Analysis (FMEA), or equivalent risk analysis, of your application, and apply preventive and detective controls before implementation.
- Provide a fallback state for undesired control events or sequences.
- Provide separate or redundant control paths wherever required.
- Supply appropriate parameters, particularly for limits.
- Review the implications of transmission delays and take actions to mitigate them.
- Review the implications of communication link interruptions and take actions to mitigate them.
- Provide independent paths for control functions (for example, emergency stop, over-limit conditions, and error conditions) according to your risk assessment, and applicable codes and regulations.
- Apply local accident prevention and safety regulations and guidelines.¹
- Test each implementation of a system for proper operation before placing it into service.

Failure to follow these instructions can result in death, serious injury, or equipment damage.

¹ For additional information, refer to NEMA ICS 1.1 (latest edition), *Safety Guidelines for the Application, Installation, and Maintenance of Solid State Control* and to NEMA ICS 7.1 (latest edition), *Safety Standards for Construction and Guide for Selection, Installation and Operation of Adjustable-Speed Drive Systems* or their equivalent governing your particular location.

Wiring Guidelines

The following rules must be applied when wiring a TM3 system:

- I/O and communication wiring must be kept separate from the power wiring. Route these 2 types of wiring in separate cable ducting.
- Verify that the operating conditions and environment are within the specification values.
- Use proper wire sizes to meet voltage and current requirements.
- Use copper conductors.
- Use twisted-pair, shielded cables for analog, and/or fast I/O.
- Use twisted-pair, shielded cables for networks, and field bus.

⚠ WARNING

UNINTENDED EQUIPMENT OPERATION

- Use shielded cables for all fast I/O, analog I/O, and communication signals.
- Ground cable shields for all fast I/O, analog I/O, and communication signals at a single point¹.
- Route communications and I/O cables separately from power cables.

Failure to follow these instructions can result in death, serious injury, or equipment damage.

¹Multipoint grounding is permissible if connections are made to an equipotential ground plane dimensioned to help avoid cable shield damage in the event of power system short-circuit currents.

NOTE: Surface temperatures may exceed 60 °C (140 °F).

To conform to IEC 61010 standards, route primary wiring (wires connected to power mains) separately and apart from secondary wiring (extra low voltage wiring coming from intervening power sources). If that is not possible, double insulation is required such as conduit or cable gains.

Rules for Removable Screw Terminal Block

The following tables show the cable types and wire sizes for a **3.81 pitch** removable screw terminal block (I/Os and power supply):

mm ²	0.14...1.5	0.14...1.5	0.25...1.5	0.25...0.5	2 x 0.14...0.5	2 x 0.14...0.75	2 x 0.25...0.34	2 x 0.5
AWG	26...16	26...16	22...16	22...20	2 x 26...20	2 x 26...20	2 x 24...22	2 x 20
			N•m		0.28			
Ø 2,5 mm (0.1 in.)			lb-in		2.48			

The following tables show the cable types and wire sizes for a **5.08 pitch** removable screw terminal block (I/Os and power supply):

mm ²	0.2...2.5	0.2...2.5	0.25...2.5	0.25...2.5	2 x 0.2...1	2 x 0.2...1.5	2 x 0.25...1	2 x 0.5...1.5
AWG	24...14	24...14	23...14	23...14	2 x 24...17	2 x 24...16	2 x 23...17	2 x 20...16
			N•m		0.49			
Ø 3,5 mm (0.14 in.)			lb-in		4.34			

The use of copper conductors is required.

⚠ DANGER

FIRE HAZARD

Use only the correct wire sizes for the maximum current capacity of the I/O channels and power supplies.

Failure to follow these instructions will result in death or serious injury.

Rules for Removable Spring Terminal Block

The following tables show the cable types and wire sizes for a **3.81 pitch** removable spring terminal block (I/Os and power supply):

mm in.					
mm ²		0.5...1.5	0.5...1.5	0.25...1.0	0.25...0.5
AWG		21...16	21...16	23...18	23...21

The following tables show the cable types and wire sizes for a **5.08 pitch** removable spring terminal block (I/Os and power supply):

mm in.					
mm ²		0.2...2.5	0.2...2.5	0.25...2.5	0.25...2.5
AWG		24...14	24...14	23...14	23...14
					2 x 0.5...1
					2 x 20...17

The use of copper conductors is required.

⚠ DANGER

FIRE HAZARD

Use only the correct wire sizes for the maximum current capacity of the I/O channels and power supplies.

Failure to follow these instructions will result in death or serious injury.

The spring clamp connectors of the terminal block are designed for only one wire or one cable end. Two wires to the same connector must be installed with a double wire cable end to help prevent loosening.

⚠⚠ DANGER

LOOSE WIRING CAUSES ELECTRIC SHOCK

Do not insert more than one wire per connector of the spring terminal blocks unless using a double wire cable end (ferrule).

Failure to follow these instructions will result in death or serious injury.

DC Power Supply Characteristics

Overview

This section provides the characteristics of the DC power supply.

Power Supply Voltage Range

If the specified voltage range is not maintained, outputs may not switch as expected. Use appropriate safety interlocks and voltage monitoring circuits.

⚠ DANGER

FIRE HAZARD

Use only the correct wire sizes for the maximum current capacity of the I/O channels and power supplies.

Failure to follow these instructions will result in death or serious injury.

⚠ WARNING**UNINTENDED EQUIPMENT OPERATION**

Do not exceed any of the rated values specified in the environmental and electrical characteristics tables.

Failure to follow these instructions can result in death, serious injury, or equipment damage.

DC Power Supply Characteristics

The 24 Vdc power supplies must be rated Protective Extra Low Voltage (PELV) according to IEC 61140. These power supplies are isolated between the electrical input and output circuits of the power supply.

⚠ WARNING**POTENTIAL OF OVERHEATING AND FIRE**

- Do not connect the equipment directly to line voltage.
- Use only isolating PELV power supplies to supply power to the equipment¹.

Failure to follow these instructions can result in death, serious injury, or equipment damage.

¹For compliance to UL (Underwriters Laboratories) requirements, the power supply must also conform to the various criteria of NEC Class 2, and be inherently current limited to a maximum power output availability of less than 100 VA (approximately 4 A at nominal voltage), or not inherently limited but with an additional protection device such as a circuit breaker or fuse meeting the requirements of clause 9.4 Limited-energy circuit of UL 61010-1. In all cases, the current limit should never exceed that of the electric characteristics and wiring diagrams for the equipment described in the present documentation. In all cases, the power supply must be grounded, and you must separate Class 2 circuits from other circuits. If the indicated rating of the electrical characteristics or wiring diagrams are greater than the specified current limit, multiple Class 2 power supplies may be used.

Grounding the TM3 Analog I/O Modules

Overview

Due to the effects of electromagnetic interference, cables carrying fast I/O, analog I/O, and the fieldbus communication signals must be shielded.

⚠ WARNING**UNINTENDED EQUIPMENT OPERATION**

- Use shielded cables for all fast I/O, analog I/O, and communication signals.
- Ground cable shields for all fast I/O, analog I/O, and communication signals at a single point¹.
- Route communications and I/O cables separately from power cables.

Failure to follow these instructions can result in death, serious injury, or equipment damage.

¹Multipoint grounding is permissible if connections are made to an equipotential ground plane dimensioned to help avoid cable shield damage in the event of power system short-circuit currents.

The use of shielded cables requires compliance with the following wiring rules:

- For protective earth ground connections (PE), metal conduit or ducting can be used for part of the shielding length, provided there is no break in the continuity of the ground connections. For functional earth ground (FE), the shielding is intended to attenuate electromagnetic interference and the shielding must be continuous for the length of the cable. If the purpose is both functional and protective, as is often the case for communication cables, the cable must have continuous shielding.
- Wherever possible, keep cables carrying one type of signal separate from the cables carrying other types of signals or power.

Shielded Cables Connections

Cables carrying fast I/O, analog I/O, and the fieldbus communication signals must be shielded. The shielding must be securely connected to ground. Fast I/O and analog I/O shields may be connected either to the functional earth ground (FE) or to the protective earth ground (PE) of your TM3 expansion module. The fieldbus communication cable shields must be connected to the protective earth ground (PE) with a connecting clamp secured to the conductive backplane of your installation.

Protective Earth Ground (PE) on the Backplane

The protective earth ground (PE) is connected to the conductive backplane by a heavy-duty wire, usually a braided copper cable with the maximum allowable cable section.

▲ WARNING
INACCURATE ANALOG CONVERSIONS
Make sure that an appropriate, braided ground cable is attached to the ground terminal of the module and securely attached to the protective earth ground connection of your system.
Failure to follow these instructions can result in death, serious injury, or equipment damage.

Functional Earth Ground (FE) on the DIN Rail

The DIN Rail for your TM3 system is common with the functional earth ground (FE) plane and must be mounted on a conductive backplane.

▲ WARNING
UNINTENDED EQUIPMENT OPERATION
Connect the DIN rail to the functional earth ground (FE) of your installation.
Failure to follow these instructions can result in death, serious injury, or equipment damage.

Functional Earth Ground (FE) Connections

To connect the functional earth ground (FE):

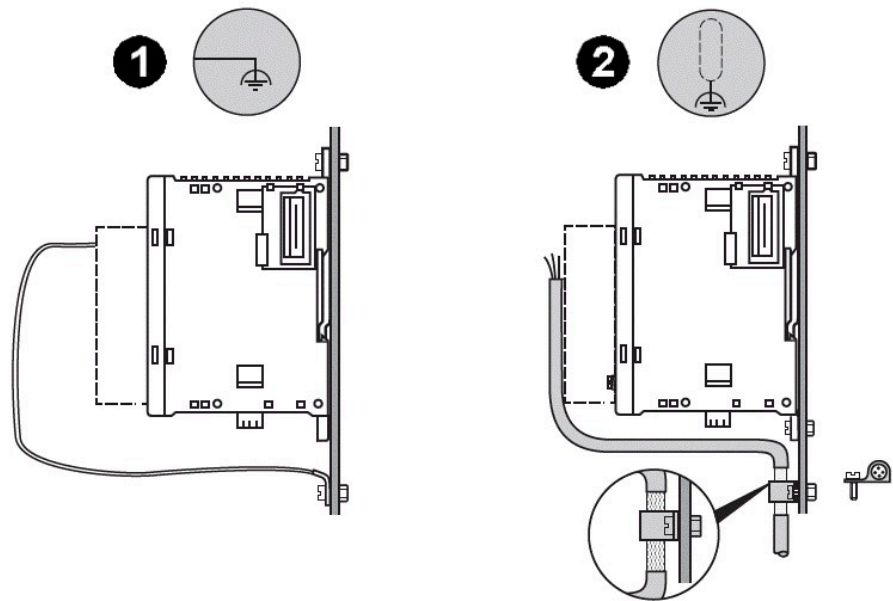

Label	Signification	Description
1	Grounding of the module	Connect the module to the functional earth ground (FE) terminal.
2	Grounding of the sensor	<p>Attach and ground the shielding of cables as close as possible to the controller:</p> <ol style="list-style-type: none"> Strip the shielding Attach the cable to the metal support by attaching the clamp to the stripped part of the shielding. <p>The shielding must be clamped tightly enough to the metal support to achieve good contact.</p>

TM3 Analog Input Modules

What's in This Part

TM3AI2H / TM3AI2HG Module 2 Inputs	38
TM3AI4 / TM3AI4G Module 4 Inputs	43
TM3AI8 / TM3AI8G Module 8 Inputs	48
TM3TI4 / TM3TI4G Module 4 Inputs	53
TM3TI4D / TM3TI4DG Module 4 Inputs.....	59
TM3TI8T / TM3TI8TG Module 8 Inputs	65

TM3AI2H / TM3AI2HG Module 2 Inputs

What's in This Chapter

TM3AI2H / TM3AI2HG Presentation	38
TM3AI2H / TM3AI2HG Characteristics	39
TM3AI2H / TM3AI2HG Wiring Diagram	42

Overview

This chapter describes the TM3AI2H / TM3AI2HG expansion modules, its characteristics, and its connection to the different sensors.

TM3AI2H / TM3AI2HG Presentation

Overview

TM3AI2H (screw) and TM3AI2HG (spring) analog expansion modules:

- 2 channels 16 bits (Voltage, current)
- Removable screw and spring terminal block

Main Characteristics

Characteristic		Value
Number of input channels		2 inputs
Rated power supply		24 Vdc
Signal type		Voltage Current
Input range		0...10 Vdc 0...20 mA -10...+10 Vdc 4...20 mA
Resolution		16 bits, or 15 bits + sign
Connection type	TM3AI2H	Removable screw terminal block
	TM3AI2HG	Removable spring terminal block
Cable type and length	Type	Twisted pair shielded
	Length	Maximum 30 m (98 ft)
Weight	TM3AI2H	115 g (4.05 oz)
	TM3AI2HG	100 g (3.52 oz)

Status LEDs

The following figure shows the status LEDs:



The following table describes the status LEDs:

LED	Color	Status	Description
PWR	Green	On	Indicates that TM3 bus power is applied.
		Off	Indicates that TM3 bus power is removed.

TM3AI2H / TM3AI2HG Characteristics

Introduction

This section provides a general description of the characteristics of the TM3AI2H / TM3AI2HG expansion modules.

See also Environmental Characteristics, page 20.

⚠ WARNING
UNINTENDED EQUIPMENT OPERATION
Do not exceed any of the rated values specified in the environmental and electrical characteristics tables.
Failure to follow these instructions can result in death, serious injury, or equipment damage.

Dimensions

The following diagrams show the external dimensions for the TM3AI2H / TM3AI2HG expansion modules:

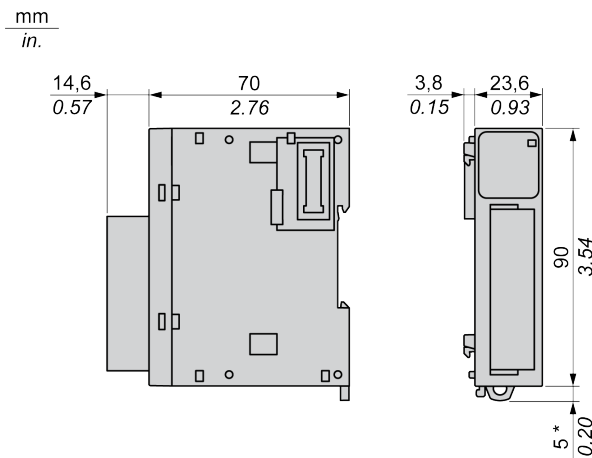

* 8.5 mm (0.33 in.) when the clamp is pulled out.

General Characteristics

Characteristics	Value
Rated power supply voltage	24 Vdc
Power supply range	20.4...28.8 Vdc
Connector insertion/removal durability	100 times minimum
Current draw on 5 Vdc internal bus	30 mA (no load) 30 mA (full load)
Current draw on 24 Vdc internal bus	0 mA
Current draw on external 24 Vdc	25 mA (no load) 25 mA (full load)

Input Characteristics

The following table describes the input characteristics of the TM3AI2H / TM3AI2HG expansion modules:

Characteristics		Value	
		Voltage input	Current input
Input range		0...10 Vdc -10...+10 Vdc	0...20 mA 4...20 mA
Input impedance		1 MΩ minimum	50 Ω maximum
Sample duration time		1 ms per enabled channel	
Input type		Single-ended input	
Operating mode		Self-scan	
Conversion mode		Sigma delta ADC	
Maximum accuracy at ambient 25 °C (77 °F)		±0.1 % of full scale	
Temperature drift		±0.006 % of full scale	
Repeatability after stabilization time		±0.5 % of full scale	
Nonlinearity		±0.01 % of full scale	
Maximum input deviation		±1.0 % of full scale	
Resolution		16 bits, or 15 bits + sign (65536 points)	
Input value of LSB		0.153 mV (range 0...10 Vdc) 0.305 mV (range -10...+10 Vdc)	0.305 μA (range 0...20 mA) 0.244 μA (range 4...20 mA)
Data type in application program		Scalable from -32768 to 32767	
Input data out of range detection		Yes	
Noise resistance	Maximum temporary deviation during perturbations	±4 % maximum when EMC perturbation is applied to the power and I/O wiring	
	Cable	Twisted-pair shielded cable, maximum 30 m	
	Crosstalk	1 LSB maximum	
Isolation	Between external power supply and inputs	1500 Vac	
	Between inputs and internal logic circuits	500 Vac	
Maximum continuous allowed overload (no damage)		13 Vdc	40 mA
Input filter		Software filter: 0...10 s (per 0.01 s unit)	
Behavior when external power is off		Input value is 0. The external power supply error status bit in the controller is ON.	

TM3AI2H / TM3AI2HG Wiring Diagram

Introduction

This expansion module has a built-in removable screw terminal block for the connection of inputs and power supply.

NOTE: Loop powered sensors are not supported by these expansion modules. The modules do not provide loop power when wired for current.

Wiring Rules

See Wiring Best Practices, page 30.

Wiring Diagram

The following figure illustrates the connection between the inputs, the sensors, and their commons:

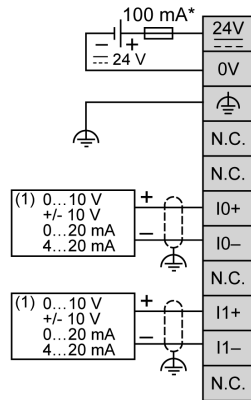

* Type T fuse

(1) Current/Voltage analog output device

⚠ WARNING
UNINTENDED EQUIPMENT OPERATION
Do not connect wires to unused terminals and/or terminals indicated as "No Connection (N.C.)".
Failure to follow these instructions can result in death, serious injury, or equipment damage.

TM3AI4 / TM3AI4G Module 4 Inputs

What's in This Chapter

TM3AI4 / TM3AI4G Presentation 43
 TM3AI4 / TM3AI4G Characteristics 44
 TM3AI4 / TM3AI4G Wiring Diagram 47

Overview

This chapter describes the TM3AI4 / TM3AI4G expansion modules, its characteristics, and its connection to the different sensors.

TM3AI4 / TM3AI4G Presentation

Overview

TM3AI4 (screw) and TM3AI4G (spring) analog expansion modules:

- 4 channels 12 bits (Voltage, current)
- Removable screw or spring terminal block

Main Characteristics

Characteristic		Value
Number of input channels		4 inputs
Rated power supply		24 Vdc
Signal type		Voltage Current
Input range		0...10 Vdc 0...20 mA -10...+10 Vdc 4...20 mA
Resolution		12 bits, or 11 bits + sign
Connection type	TM3AI4	Removable screw terminal block
	TM3AI4G	Removable spring terminal block
Cable type and length	Type	Twisted pair shielded
	Length	Maximum 30 m (98 ft)
Weight	TM3AI4	110 g (4.05 oz)
	TM3AI4G	100 g (3.52 oz)

Status LEDs

The following figure shows the status LEDs:



The following table describes the status LEDs:

LED	Color	Status	Description
PWR	Green	On	Indicates that TM3 bus power is applied.
		Off	Indicates that TM3 bus power is removed.

TM3AI4 / TM3AI4G Characteristics

Introduction

This section describes the general characteristics of the TM3AI4 / TM3AI4G expansion modules.

See also Environmental Characteristics, page 20.

⚠ WARNING
<p>UNINTENDED EQUIPMENT OPERATION</p> <p>Do not exceed any of the rated values specified in the environmental and electrical characteristics tables.</p> <p>Failure to follow these instructions can result in death, serious injury, or equipment damage.</p>

Dimensions

The following diagrams show the external dimensions for the TM3AI4 / TM3AI4G expansion modules:

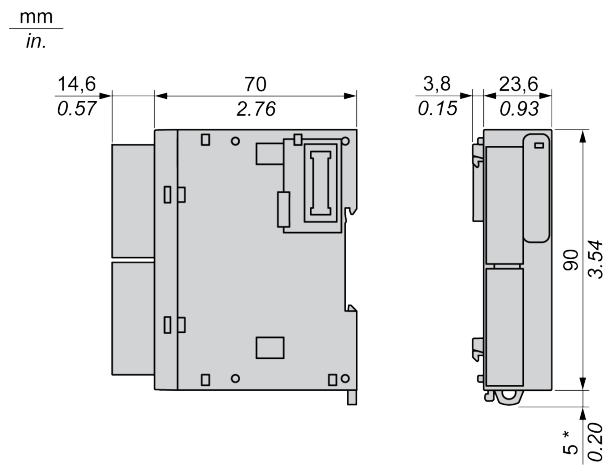

* 8.5 mm (0.33 in.) when the clamp is pulled out.

General Characteristics

Characteristics	Value
Rated power supply voltage	24 Vdc
Power supply range	20.4...28.8 Vdc
Connector insertion/removal durability	100 times minimum
Current draw on 5 Vdc internal bus	40 mA (no load) 40 mA (full load)
Current draw on 24 Vdc internal bus	0 mA
Current draw on external 24 Vdc	30 mA (no load) 30 mA (full load)

Input Characteristics

The following table describes the input characteristics of the TM3AI4 / TM3AI4G expansion modules:

Characteristics		Value	
		Voltage input	Current input
Input range		0...10 Vdc -10...+10 Vdc	0...20 mA 4...20 mA
Input impedance		1 M Ω minimum	50 Ω maximum
Sample duration time		1 ms per enabled channel	
Input type		Single-ended input	
Operating mode		Self-scan	
Conversion mode		Sigma delta ADC	
Maximum accuracy at ambient 25 °C (77 °F)		± 0.2 % of full scale	
Temperature drift		± 0.01 % of full scale	
Repeatability after stabilization time		± 0.5 % of full scale	
Nonlinearity		± 0.2 % of full scale	
Maximum input deviation		± 1.0 % of full scale	
Resolution		12 bits, or 11 bits + sign (4096 points)	
Input value of LSB		2.44 mV (range 0...10 Vdc) 4.88 mV (range -10...+10 Vdc)	4.88 μ A (range 0...20 mA) 3.91 μ A (range 4...20 mA)
Data type in application program		Scalable from -32768 to 32767	
Input data out of range detection		Yes	
Noise resistance	Maximum temporary deviation during perturbations	± 4 % maximum when EMC perturbation is applied to the power and I/O wiring	
	Cable	Twisted-pair shielded cable, maximum 30 m	
	Crosstalk	1 LSB maximum	
Isolation	Between external power supply and inputs	1500 Vac	
	Between inputs and internal logic circuits	500 Vac	
Maximum continuous allowed overload (no damage)		13 Vdc	40 mA
Input filter		Software filter: 0...10 s (per 0.01 s unit)	
Behavior when external power is off		Input value is 0. The external power supply error status bit in the controller is ON.	

TM3AI4 / TM3AI4G Wiring Diagram

Introduction

These expansion modules have a built-in removable screw or spring terminal block for the connection of inputs and power supply.

NOTE: Loop powered sensors are not supported by these expansion modules. The modules do not provide loop power when wired for current.

Wiring Rules

See Wiring Best Practices, page 30.

Wiring Diagram

The following figure illustrates the connection between the inputs, the sensors, and their commons:

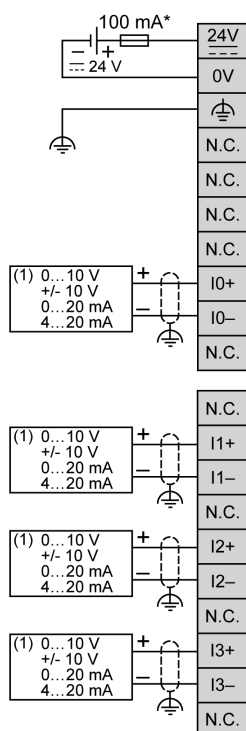

* Type T fuse

(1) Current/Voltage analog output device

⚠ WARNING
UNINTENDED EQUIPMENT OPERATION
Do not connect wires to unused terminals and/or terminals indicated as “No Connection (N.C.)”.
Failure to follow these instructions can result in death, serious injury, or equipment damage.

TM3AI8 / TM3AI8G Module 8 Inputs

What's in This Chapter

TM3AI8 / TM3AI8G Presentation	48
TM3AI8 / TM3AI8G Characteristics	49
TM3AI8 / TM3AI8G Wiring Diagram	52

Overview

This chapter describes the TM3AI8 / TM3AI8G expansion modules, their characteristics, and their connection to the different sensors.

TM3AI8 / TM3AI8G Presentation

Overview

TM3AI8 (screw) and TM3AI8G (spring) analog expansion modules:

- 8 channels 12 bits (Voltage, current)
- Removable screw or spring terminal block

Model Name

TM3AI8 / TM3AI8G expansion modules may present a **model name**, respectively TM3AI8-B / TM3AI8G-B.

NOTE: The **model name** depends on the production site and does not impact the module characteristics.

Main Characteristics

Characteristic	Value	
Number of input channels	8 inputs	
Rated power supply	24 Vdc	
Signal type	Voltage	Current
Input range	0...10 Vdc	0...20 mA
	-10...+10 Vdc	4...20 mA 0...20 mA extended 4...20 mA extended
Resolution	12 bits, or 11 bits + sign	
Connection type	TM3AI8	Removable screw terminal block
	TM3AI8G	Removable spring terminal block
Cable type and length	Type	Twisted pair shielded
	Length	Maximum 30 m (98 ft)
Weight	TM3AI8	110 g (3.88 oz)
	TM3AI8G	100 g (3.52 oz)

Status LEDs

The following figure shows the status LEDs:



The following table describes the status LEDs:

LED	Color	Status	Description
PWR	Green	On	Indicates that TM3 bus power is applied.
		Off	Indicates that TM3 bus power is removed.

TM3AI8 / TM3AI8G Characteristics

Introduction

This section provides a description of the input characteristics of TM3AI8 / TM3AI8G expansion modules.

See also Environmental Characteristics, page 20.

▲ WARNING
<p>UNINTENDED EQUIPMENT OPERATION</p> <p>Do not exceed any of the rated values specified in the environmental and electrical characteristics tables.</p> <p>Failure to follow these instructions can result in death, serious injury, or equipment damage.</p>

Dimensions

The following diagrams show the external dimensions for the TM3AI8 / TM3AI8G expansion modules:

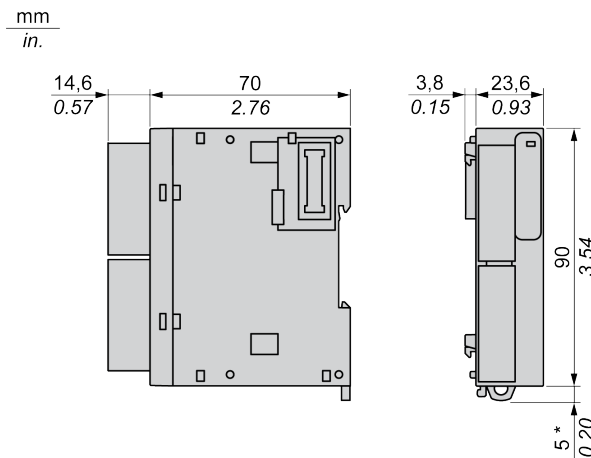

* 8.5 mm (0.33 in.) when the clamp is pulled out.

General Characteristics

Characteristics	Value
Rated power supply voltage	24 Vdc
Power supply range	20.4...28.8 Vdc
Connector insertion/removal durability	100 times minimum
Current draw on 5 Vdc internal bus	35 mA (no load) 35 mA (full load)
Current draw on 24 Vdc internal bus	0 mA
Current draw on external 24 Vdc	30 mA (no load) 40 mA (full load)

Input Characteristics

The following table describes the input characteristics of the TM3AI8 / TM3AI8G expansion modules:

Characteristics		Value	
		Voltage input	Current input
Input range		0...10 Vdc -10...+10 Vdc	0...20 mA 4...20 mA 0...20 mA extended 4...20 mA extended
Input impedance		1 MΩ minimum	50 Ω maximum
Sample duration time		1 ms per enabled channel	
Input type		Single-ended input	
Operating mode		Self-scan	
Conversion mode		Sigma delta ADC	
Maximum accuracy at ambient 25 °C (77 °F)		±0.2 % of full scale	
Temperature drift		±0.01 % of full scale	
Repeatability after stabilization time		±0.5 % of full scale	
Nonlinearity		±0.2 % of full scale	
Maximum input deviation		±1.0 % of full scale	
Resolution		12 bits, or 11 bits + sign (4096 points)	
Input value of LSB		2.44 mV (range 0...10 Vdc) 4.88 mV (range -10...+10 Vdc)	4.88 μA (range 0...20 mA) 3.91 μA (range 4...20 mA)
Data type in application program		Scalable from -32768 to 32767	
Input data out of range detection		Yes	
Noise resistance	Maximum temporary deviation during perturbations	±4 % maximum when EMC perturbation is applied to the power and I/O wiring	
	Cable	Twisted-pair shielded cable, maximum 30 m	
	Crosstalk	1 LSB maximum	
Isolation	Between external power supply and inputs	1500 Vac	
	Between inputs and internal logic circuits	500 Vac	
Maximum continuous allowed overload (no damage)		13 Vdc	40 mA
Input filter		Software filter: 0...10 s (per 0.01 s unit)	
Behavior when external power is off		Input value is 0. The external power supply error status bit in the controller is ON.	

TM3AI8 / TM3AI8G Wiring Diagram

Introduction

These expansion modules have a built-in removable screw or spring terminal block for the connection of inputs and power supply.

NOTE: Loop powered sensors are not supported by these expansion modules. The modules do not provide loop power when wired for current.

Wiring Rules

See Wiring Best Practices, page 30.

Wiring Diagram

The following figure illustrates the connection between the inputs, the sensors, and their commons:

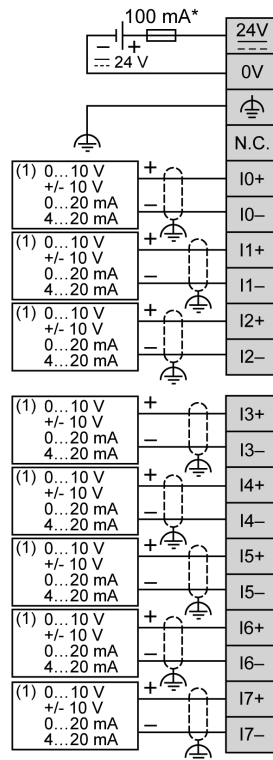

* Type T fuse

(1) Current/Voltage analog output device

⚠ WARNING
UNINTENDED EQUIPMENT OPERATION
Do not connect wires to unused terminals and/or terminals indicated as “No Connection (N.C.)”.
Failure to follow these instructions can result in death, serious injury, or equipment damage.

TM3TI4 / TM3TI4G Module 4 Inputs

What's in This Chapter

TM3TI4 / TM3TI4G Presentation 53
 TM3TI4 / TM3TI4G Characteristics 54
 TM3TI4 / TM3TI4G Wiring Diagram 58

Overview

This chapter describes the TM3TI4 / TM3TI4G expansion modules, its characteristics, and its connection to the different sensors.

TM3TI4 / TM3TI4G Presentation

Overview

TM3TI4 (screw) and TM3TI4G (spring) analog expansion modules:

- 4 channels 16 bits (Voltage, current, isolated thermocouple, 3-wire-RTD)
- Removable screw or spring terminal block

Main Characteristics

Characteristic	Value			
Number of input channels	4 inputs			
Rated power supply	24 Vdc			
Signal type	Voltage	Current	Thermocouple	3-wire-RTD
Input range	0...10 Vdc -10...+10 Vdc	0...20 mA 4...20 mA	Type K, J, R, S, B, E, T, N, C	PT100, PT1000, NI100, NI1000
Resolution max	16 bits, or 15 bits + sign (65536 points)			
Connection type	TM3TI4	Removable screw terminal block		
	TM3TI4G	Removable spring terminal block		
Cable type and length	Type	Twisted pair shielded		
	Length	Maximum 30 m (98 ft)		
Weight	TM3TI4	110 g (3.88 oz)		
	TM3TI4G	100 g (3.52 oz)		

Status LEDs

The following figure shows the status LEDs:



The following table describes the status LEDs:

LED	Color	Status	Description
PWR	Green	On	Indicates that TM3 bus power is applied.
		Off	Indicates that TM3 bus power is removed.

TM3TI4 / TM3TI4G Characteristics

Introduction

This section provides a description of the input characteristics of TM3TI4 / TM3TI4G expansion modules.

See also Environmental Characteristics, page 20.

⚠ WARNING
<p>UNINTENDED EQUIPMENT OPERATION</p> <p>Do not exceed any of the rated values specified in the environmental and electrical characteristics tables.</p> <p>Failure to follow these instructions can result in death, serious injury, or equipment damage.</p>

Dimensions

The following diagrams show the external dimensions for the TM3TI4 / TM3TI4G expansion modules:

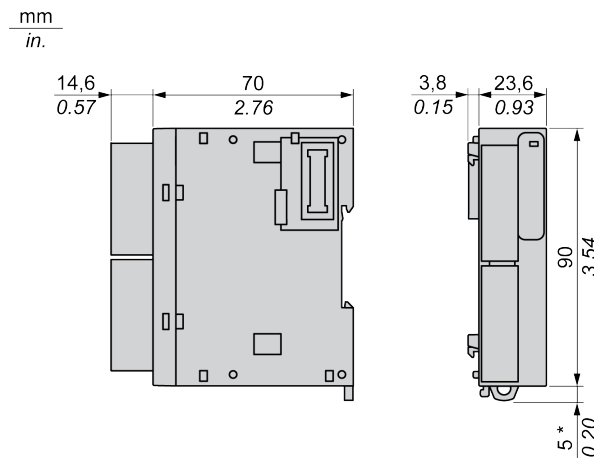

* 8.5 mm (0.33 in.) when the clamp is pulled out.

General Characteristics

Characteristics	Value
Rated power supply voltage	24 Vdc
Power supply range	20.4...28.8 Vdc
Connector insertion/removal durability	100 times minimum
Current draw on 5 Vdc internal bus	40 mA (no load) 40 mA (full load)
Current draw on 24 Vdc internal bus	0 mA
Current draw on external 24 Vdc	35 mA (no load) 40 mA (full load)

Input Characteristics

The following table describes the input characteristics of the TM3TI4 / TM3TI4G expansion modules:

Characteristics	Value					
	Voltage input	Current input	Thermocouple type		3-wire-RTD	
Input range	0...10 Vdc -10...+10 Vdc	0...20 mA 4...20 mA	K	–200...1300 °C	PT100	–200...850 °C
				(–328...2372 °F)		(–328...1562 °F)
			J	–200...1000 °C	PT1000	–200...600 °C
				(–328...1832 °F)		(–328...1112 °F)
			R	0...1760 °C	NI100	–60...180 °C
				(32...3200 °F)		(–76...356 °F)
			S	0...1760 °C	NI 1000	–60...180 °C
				(32...3200 °F)		(–76...356 °F)
			B	0...1820 °C (32...3308 °F)	–	
E	–200...800 °C (–328...1472 °F)					
T	–200...400 °C (–328...752 °F)					
N	–200...1300 °C (–328...2372 °F)					
C	0...2315 °C (32...4199 °F)					
Input impedance	1 MΩ minimum	50 Ω maximum	1 MΩ minimum			
Sample duration time (software configurable)	10 ms or 100 ms per enabled channel		100 ms per enabled channel			
Input type	Single-ended input. Use only isolated thermocouples. All the shields of the sensor cables must be referenced to the logic controller ground.					
Operating mode	Self-scan					
Conversion mode	Sigma delta ADC					
Maximum accuracy at ambient 25 °C (77 °F)	±0.2 % of full scale					
	–		Cold junction accuracy ±4.0 °C (±7.2 °F)		–	
			except:			
			R	±6.0 °C (0...200 °C) (±10.8 °F (32...392 °F))		
			S	±6.0 °C (0...200 °C) (±10.8 °F (32...392 °F))		
		B	Not available (0...300 °C (32...572 °F))			
		K	±0.4 % of full scale under 0 °C (32 °F)			
		J				
		E				
		T				
		N				
Temperature drift	±0.01 % of full scale					
Repeatability after stabilization time	±0.5 % of full scale					

Characteristics	Value					
	Voltage input	Current input	Thermocouple type	3-wire-RTD		
Nonlinearity	±0.2 % of full scale					
Maximum input deviation	±1.0 % of full scale					
Resolution	16 bits, or 15 bits + sign (65536 points)		K	15000 points	PT100	10500 points
			J	12000 points	PT1000	8000 points
			R	17600 points	NI100	2400 points
			S	17600 points	NI1000	2400 points
			B	18200 points		
			E	10000 points		
			T	6000 points		
			N	15000 points		
			C	23150 points		
Input value of LSB	0.153 mV (range 0...10 Vdc) 0.305 mV (range -10...+10 Vdc)	0.305 µA (range 0...20 mA) 0.244 µA (range 4...20 mA)	0.1 °C (0.18 °F)			
Data type in application program	Scalable from -32768 to 32767					
Input data out of range detection	Yes					
Noise resistance	Maximum temporary deviation during perturbations	±4 % maximum when EMC perturbation is applied to the power and I/O wiring				
	Cable	Twisted-pair shielded cable				
	Crosstalk	1 LSB maximum				
Isolation	Between external power supply and inputs	1500 Vac				
	Between inputs and internal logic circuits	500 Vac				
	Between inputs	Not isolated				
Maximum continuous allowed overload (no damage)	13 Vdc	40 mA	N/A			
Input filter	Software filter: 0...10 s (per 0.01 s unit)					
Behavior when temperature sensor is broken	N/A		Input value is highest limit value. Highest limit flag is ON.			
Behavior when external power is off	Input value is 0.		Input value is highest limit value.			
	The external power supply error status bit in the controller is ON.					

TM3TI4 / TM3TI4G Wiring Diagram

Introduction

These expansion modules have a built-in removable screw or spring terminal block for the connection of inputs and power supply.

Wiring Rules

See Wiring Best Practices, page 30.

Wiring Diagram

The following figure illustrates the connection between the inputs, the sensors, and their commons:

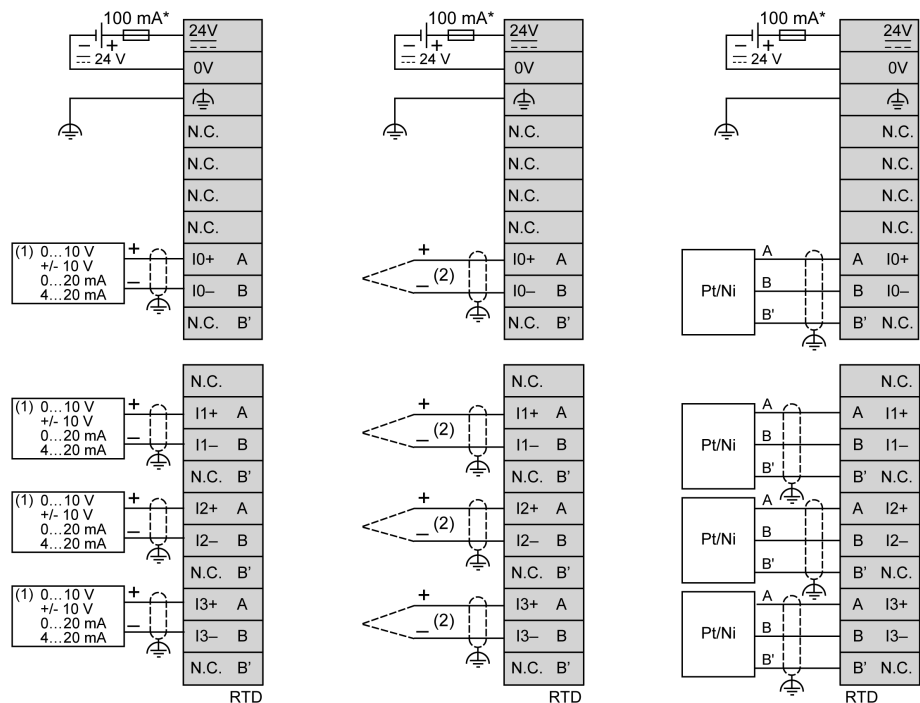

* Type T fuse

(1) Current/Voltage analog output device

(2) Electrically isolated thermocouple only

RTD (A, B, B'): Resistance Temperature Detector

⚠ WARNING

UNINTENDED EQUIPMENT OPERATION

Do not connect wires to unused terminals and/or terminals indicated as "No Connection (N.C.)".

Failure to follow these instructions can result in death, serious injury, or equipment damage.

TM3TI4D / TM3TI4DG Module 4 Inputs

What's in This Chapter

TM3TI4D / TM3TI4DG Presentation..... 59
 TM3TI4D / TM3TI4DG Characteristics 60
 TM3TI4D / TM3TI4DG Wiring Diagram 64

Overview

This chapter describes the TM3TI4D / TM3TI4DG expansion modules, its characteristics, and its connection to the different sensors.

TM3TI4D / TM3TI4DG Presentation

Overview

- TM3TI4D (screw) and TM3TI4DG (spring) analog expansion modules:
- 4 channels 16 bits, electrically isolated or non isolated thermocouple
 - Removable screw or spring terminal block

Main Characteristics

Characteristic	Value	
Number of input channels	4 inputs	
Rated power supply	24 Vdc	
Signal type	Electrically isolated or non isolated thermocouple	
Input range	Type K, J, R, S, B, E, T, N, C	
Resolution max	16 bits, or 15 bits + sign (65536 points)	
Connection type	TM3TI4D	Removable screw terminal block
	TM3TI4DG	Removable spring terminal block
Cable type and length	Type	Twisted pair shielded
	Length	Maximum 30 m (98 ft)
Weight	TM3TI4D	110 g (3.88 oz)
	TM3TI4DG	100 g (3.52 oz)

Status LEDs

The following figure shows the status LEDs:



The following table describes the status LEDs:

LED	Color	Status	Description
PWR	Green	On	Indicates that TM3 bus power is applied.
		Off	Indicates that TM3 bus power is removed.

TM3TI4D / TM3TI4DG Characteristics

Introduction

This section provides a description of the input characteristics of TM3TI4D / TM3TI4DG expansion modules.

See also Environmental Characteristics, page 20.

⚠ WARNING
<p>UNINTENDED EQUIPMENT OPERATION</p> <p>Do not exceed any of the rated values specified in the environmental and electrical characteristics tables.</p> <p>Failure to follow these instructions can result in death, serious injury, or equipment damage.</p>

Dimensions

The following diagrams show the external dimensions for the TM3TI4D / TM3TI4DG expansion modules:

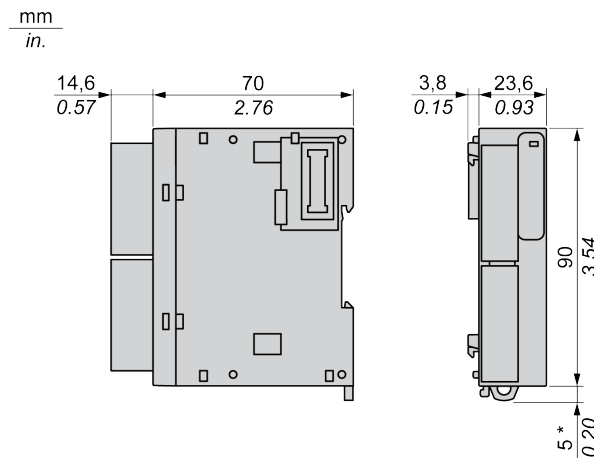

* 8.5 mm (0.33 in.) when the clamp is pulled out.

General Characteristics

Characteristics	Value
Rated power supply voltage	24 Vdc
Power supply range	20.4...28.8 Vdc
Connector insertion/removal durability	100 times minimum
Current draw on 5 Vdc internal bus	40 mA (no load) 40 mA (full load)
Current draw on 24 Vdc internal bus	0 mA
Current draw on external 24 Vdc	35 mA (no load) 40 mA (full load)

Input Characteristics

The following table describes the input characteristics of the TM3TI4D / TM3TI4DG expansion modules:

Characteristics	Value	
	Thermocouple type	
Input range	K	–200...1300 °C (–328...2372 °F)
	J	–200...1000 °C (–328...1832 °F)
	R	0...1760 °C (32...3200 °F)
	S	0...1760 °C (32...3200 °F)
	B	0...1820 °C (32...3308 °F)
	E	–200...800 °C (–328...1472 °F)
	T	–200...400 °C (–328...752 °F)
	N	–200...1300 °C (–328...2372 °F)
	C	0...2315 °C (32...4199 °F)
Input impedance	1 MΩ minimum	
Sample duration time (software configurable)	100 ms per enabled channel	
Input type	Single-ended input. Use isolated or non isolated thermocouples. All the shields of the sensor cables must be referenced to the logic controller ground.	
Operating mode	Self-scan	
Conversion mode	Sigma delta ADC	
Maximum accuracy at ambient 25 °C (77 °F)	±0.2 % of full scale	
	Cold junction accuracy ±4.0 °C (±7.2 °F)	
	except:	
	R S	±6.0 °C (0...200 °C) (±10.8 °F (32...392 °F))
	B	Not available (0...300 °C (32...572 °F))
	K J E T N	±0.4 % of full scale under 0 °C (32 °F)
Temperature drift	±0.01 % of full scale	
Repeatability after stabilization time	±0.5 % of full scale	
Nonlinearity	±0.2 % of full scale	

Characteristics		Value
		Thermocouple type
Maximum input deviation	±1.0 % of full scale	
Resolution	K J R S B E T N C	15000 points 12000 points 17600 points 17600 points 18200 points 10000 points 6000 points 15000 points 23150 points
Input value of LSB	0.1 °C (0.18 °F)	
Data type in application program	Scalable from –32768 to 32767	
Input data out of range detection	Yes	
Noise resistance	Maximum temporary deviation during perturbations	±4 % maximum when EMC perturbation is applied to the power and I/O wiring
	Cable	Twisted-pair shielded cable
	Crosstalk	1 LSB maximum
Isolation	Between external power supply and inputs	1500 Vac
	Between inputs and internal logic circuits	500 Vac
	Between inputs	250 Vac
Maximum continuous allowed overload (no damage)	N/A	
Input filter	Software filter: 0...10 s (per 0.01 s unit)	
Behavior when temperature sensor is broken	Input value is highest limit value. Highest limit flag is ON.	
Behavior when external power is off	Input value is highest limit value. The external power supply error status bit in the controller is ON.	

TM3TI4D / TM3TI4DG Wiring Diagram

Introduction

These expansion modules have a built-in removable screw or spring terminal block for the connection of inputs and power supply.

Wiring Rules

See Wiring Best Practices, page 30.

Wiring Diagram

The following figure illustrates the connection between the inputs, the sensors, and their commons:

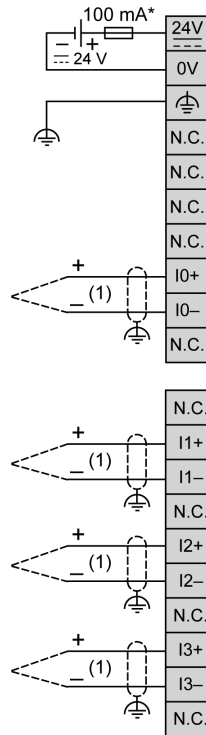

* Type T fuse

(1) Electrically isolated or non isolated thermocouple

⚠ WARNING
UNINTENDED EQUIPMENT OPERATION
Do not connect wires to unused terminals and/or terminals indicated as "No Connection (N.C.)".
Failure to follow these instructions can result in death, serious injury, or equipment damage.

TM3TI8T / TM3TI8TG Module 8 Inputs

What's in This Chapter

TM3TI8T / TM3TI8TG Presentation 65
 TM3TI8T / TM3TI8TG Characteristics 66
 TM3TI8T / TM3TI8TG Wiring Diagram 70

Overview

This chapter describes the TM3TI8T / TM3TI8TG expansion modules, its characteristics, and its connection to the different sensors.

TM3TI8T / TM3TI8TG Presentation

Overview

TM3TI8T (screw) and TM3TI8TG (spring) analog expansion modules:

- 8 channels 16 bits (thermocouple, thermistor, resistor)
- Removable screw or spring terminal block

Main Characteristics

Characteristic	Value		
Number of input channels	8 inputs		
Rated power supply	24 Vdc		
Signal type	Thermocouple	Thermistor	Resistor
Input range	Type K, J, R, S, B, E, T, N, C	NTC, PTC	Ohmmeter
Resolution max	16 bits, or 15 bits + sign (65536 points)		
Connection type	TM3TI8T	Removable screw terminal block	
	TM3TI8TG	Removable spring terminal block	
Cable type and length	Type	Twisted pair shielded	
	Length	Maximum 30 m (98 ft)	
Weight	TM3TI8T	110 g (3.88 oz)	
	TM3TI8TG	100 g (3.52 oz)	

Status LEDs

The following figure shows the status LEDs:



The following table describes the status LEDs:

LED	Color	Status	Description
PWR	Green	On	Indicates that TM3 bus power is applied.
		Off	Indicates that TM3 bus power is removed.

TM3TI8T / TM3TI8TG Characteristics

Introduction

This section provides a description of the electrical and input/output characteristics of the TM3TI8T / TM3TI8TG expansion modules.

See also Environmental Characteristics, page 20.

⚠ WARNING
<p>UNINTENDED EQUIPMENT OPERATION</p> <p>Do not exceed any of the rated values specified in the environmental and electrical characteristics tables.</p> <p>Failure to follow these instructions can result in death, serious injury, or equipment damage.</p>

Dimensions

The following diagrams show the external dimensions for the TM3TI8T / TM3TI8TG expansion modules:

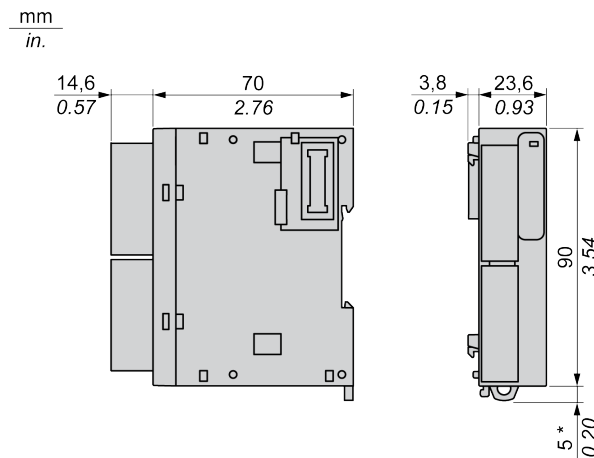

* 8.5 mm (0.33 in) when the clamp is pulled out.

General Characteristics

Characteristics	Value
Rated power supply voltage	24 Vdc
Power supply range	20.4...28.8 Vdc
Connector insertion/removal durability	100 times minimum
Current draw on 5 Vdc internal bus	30 mA (no load) 30 mA (full load)
Current draw on 24 Vdc internal bus	0 mA
Current draw on external 24 Vdc	30 mA (no load) 30 mA (full load)

Input Characteristics

The following table describes the input characteristics of the TM3TI8T / TM3TI8TG expansion modules:

Characteristics	Value				
	Thermocouple type		Thermistor		Resistor
Input range	K	-200...1300 °C (-328...2372 °F)	NTC	Measured resistor range: 100 Ω...200 kΩ Calculated temperature range: -90...150 °C (-130...302 °F)	100 Ω...32 kΩ
	J	-200...1000 °C (-328...1832 °F)			
	R	0...1760 °C (32...3200 °F)			
	S	0...1760 °C (32...3200 °F)			
	B	0...1820 °C (32...3308 °F)			
	E	-200...800 °C (-328...1472 °F)	PTC	100 Ω...10 kΩ	
	T	-200...400 °C (-328...752 °F)			
	N	-200...1300 °C (-328...2372 °F)			
	C	0...2315 °C (32...4199 °F)			
Input impedance	1 MΩ minimum				
Sample duration time	100 ms per enabled channel				
Input type	Single-ended input. Use only isolated thermocouples. All the shields of the sensor cables must be referenced to the logic controller ground.				
Operating mode	Self-scan				
Conversion mode	Sigma delta ADC				
Maximum accuracy at ambient 25 °C (77 °F)	±0.2 % of full scale Except:		NTC PTC	Value is that of the thermistor used	-
	R	±6 °C at 0...200 °C (±10.8 °F at 32...392 °F)			
	S				
	B	Not available at 0...300 °C (32...572 °F)			
	K	±0.4 % of full scale under 0 °C (32 °F)			
	J				
	E				
	T				
	N				
Temperature drift	±0.01 % of full scale				
Repeatability after stabilization time	±0.5 % of full scale				
Nonlinearity	±0.2 % of full scale				
Maximum input deviation	±1.0 % of full scale				

Characteristics		Value				
		Thermocouple type		Thermistor		Resistor
Resolution	K	15000 points	NTC	2400 points	31900 points (100...32000 Ω)	
	J	12000 points		(-90...150 °C)		
	R	17600 points	PTC	9900 points (100...10000 Ω)		
	S	17600 points				
	B	18200 points				
	E	10000 points				
	T	6000 points				
	N	15000 points				
	C	23150 points				
Input value of LSB		0.1 °C (0.18 °F)		NTC	1 Ω or 0.1 °C (0.18 °F)	-
				PTC	1 Ω	
Thermistor parameters (configuration per channel)		-		R: 0...65535 (1 Ω /LSB) T: 1...1000 (1 °C/LSB) B: 1...32767 (1 K/LSB)		-
Data type in application program		Scalable from -32768 to 32767				
Input data out of range detection		Yes				
Noise resistance	Maximum temporary deviation during perturbations	±4 % maximum when EMC perturbation is applied to the power and I/O wiring				
	Cable	Twisted-pair shielded cable				
	Crosstalk	1 LSB maximum				
Isolation	Between external power supply and inputs	1500 Vac				
	Between inputs and internal logic circuits	500 Vac				
Maximum continuous allowed overload (no damage)		N/A				
Input filter		Software filter: 0...10 s (per 0.01 s unit)				
Behavior when external power is off		Input value is not relevant. The external power supply error status bit in the controller is ON.				

TM3TI8T / TM3TI8TG Wiring Diagram

Introduction

These expansion modules have a built-in removable spring or screw terminal block for the connection of inputs and power supply.

Wiring Rules

See Wiring Best Practices, page 30.

Wiring Diagram

The following figure illustrates the connection between the inputs, the sensors, and their commons:

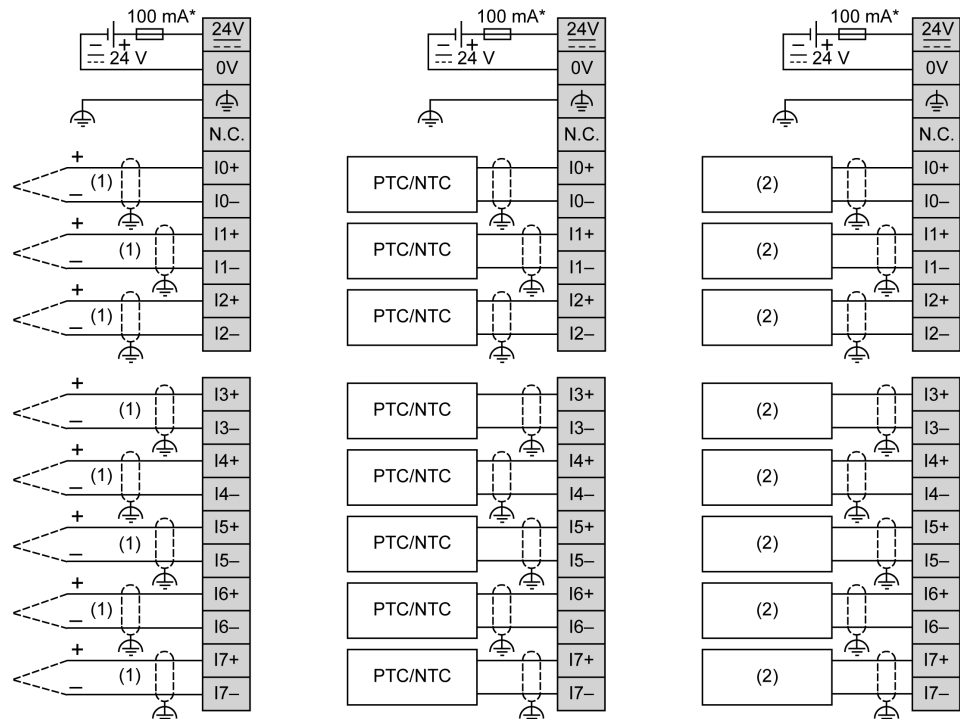

* Type T fuse

(1) Thermocouple

(2) Resistor

⚠ WARNING

UNINTENDED EQUIPMENT OPERATION

Do not connect wires to unused terminals and/or terminals indicated as "No Connection (N.C.)".

Failure to follow these instructions can result in death, serious injury, or equipment damage.

TM3 Analog Output Modules

What's in This Part

TM3AQ2 / TM3AQ2G Module 2 Outputs	72
TM3AQ4 / TM3AQ4G Module 4 Outputs	77

TM3AQ2 / TM3AQ2G Module 2 Outputs

What's in This Chapter

TM3AQ2 / TM3AQ2G Presentation.....	72
TM3AQ2 / TM3AQ2G Characteristics	73
TM3AQ2 / TM3AQ2G Wiring Diagram	76

Overview

This chapter describes the TM3AQ2 / TM3AQ2G expansion modules, its characteristics, and its connection to the different actuators.

TM3AQ2 / TM3AQ2G Presentation

Overview

TM3AQ2 (screw) and TM3AQ2G (spring) analog expansion modules:

- 2 channels 12 bits (Voltage, current)
- Removable screw or spring terminal block

Main Characteristics

Characteristic		Value
Number of output channels		2 outputs
Rated power supply		24 Vdc
Signal type		Voltage Current
Output range		0...10 Vdc 0...20 mA -10...+10 Vdc 4...20 mA
Resolution		12 bits, or 11 bits + sign
Connection type	TM3AQ2	Removable screw terminal block
	TM3AQ2G	Removable spring terminal block
Cable type and length	Type	Twisted pair shielded
	Length	Maximum 30 m (98 ft)
Weight	TM3AQ2	115 g (4.05 oz)
	TM3AQ2G	100 g (3.52 oz)

Status LEDs

The following figure shows the status LEDs:



The following table describes the status LEDs:

LED	Color	Status	Description
PWR	Green	On	Indicates that TM3 bus power is applied.
		Off	Indicates that TM3 bus power is removed.

TM3AQ2 / TM3AQ2G Characteristics

Introduction

This section provides a description of the power limitation and the output characteristics of the TM3AQ2 / TM3AQ2G expansion modules.

See also Environmental Characteristics, page 20.

⚠ WARNING

UNINTENDED EQUIPMENT OPERATION

Do not exceed any of the rated values specified in the environmental and electrical characteristics tables.

Failure to follow these instructions can result in death, serious injury, or equipment damage.

Dimensions

The following diagrams show the external dimensions for the TM3AQ2 / TM3AQ2G expansion modules:

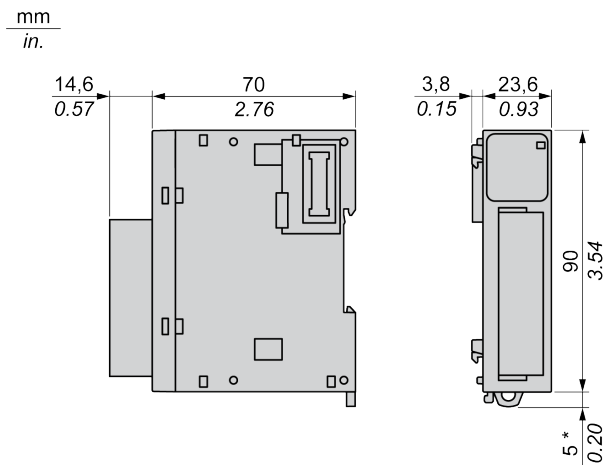

* 8.5 mm (0.33 in) when the clamp is pulled out.

General Characteristics

Characteristics	Value
Rated power supply voltage	24 Vdc
Power supply range	20.4...28.8 Vdc
Connector insertion/removal durability	100 times minimum
Current draw on 5 Vdc internal bus	30 mA (no load) 40 mA (full load)
Current draw on 24 Vdc internal bus	0 mA
Current draw on external 24 Vdc	30 mA (no load) 70 mA (full load)

Output Characteristics

The table below describes the output characteristics of the TM3AQ2 / TM3AQ2G expansion modules:

Characteristics	Value	
	Voltage output	Current output
Software configurable signal type	Voltage output	Current output
Output range	0...10 Vdc -10...+10 Vdc	0...20 mA 4...20 mA
Load impedance	1 kΩ minimum	300 Ω maximum
Application load type	Resistive load	
Settling time	1 ms	
Maximum accuracy at ambient 25 °C (77 °F)	±0.1 % of full scale	
Temperature drift	±0.006 % of full scale	
Repeatability after stabilization time	±0.4 % of full scale	
Nonlinearity	±0.01 % of full scale	
Output ripple	20 mV maximum	
Overshoot	0 %	
Maximum output deviation	±1.0 % of full scale	
Resolution	12 bits, or 11 bits + sign (4096 points)	
Input value of LSB	2.44 mV (range 0...10 Vdc) 4.88 mV (range -10...+10 Vdc)	4.88 μA (range 0...20 mA) 3.91 μA (range 4...20 mA)
Data type in application program	0...4095 (range 0...10 Vdc) -2048...+2047 (range -10...+10 Vdc)	0...4095
	Scalable from -32768 to 32767	
Input data out of range detection	Yes	
Noise resistance	Maximum temporary deviation during perturbations	±4 % maximum when EMC perturbation is applied to the power and I/O wiring
	Cable	Twisted-pair shielded cable
	Crosstalk	1 LSB maximum
Isolation	Between external power supply and inputs	1500 Vac
	Between inputs and internal logic circuits	500 Vac
Output protection	Short-circuit protection	Open-circuit protection
Behavior when external power is off	Input value is 0. The external power supply error status bit in the controller is ON.	

TM3AQ2 / TM3AQ2G Wiring Diagram

Introduction

These expansion modules have a built-in removable screw or spring terminal block for the connection of outputs and power supply.

Wiring Rules

See Wiring Best Practices, page 30.

Wiring Diagram

The following figure illustrates the connection between the outputs, the actuators, and their commons:

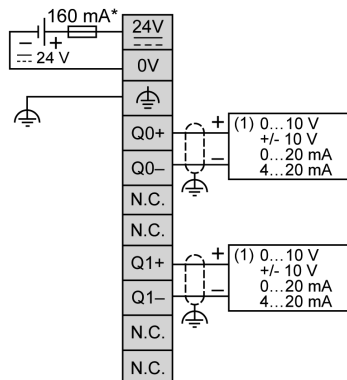

* Type T fuse

(1) Current/Voltage analog input device

⚠ WARNING
UNINTENDED EQUIPMENT OPERATION
Do not connect wires to unused terminals and/or terminals indicated as “No Connection (N.C.)”.
Failure to follow these instructions can result in death, serious injury, or equipment damage.

TM3AQ4 / TM3AQ4G Module 4 Outputs

What's in This Chapter

TM3AQ4 / TM3AQ4G Presentation..... 77
 TM3AQ4 / TM3AQ4G Characteristics 78
 TM3AQ4 / TM3AQ4G Wiring Diagram 81

Overview

This chapter describes the TM3AQ4 / TM3AQ4G expansion modules, their characteristics, and their connection to the different actuators.

TM3AQ4 / TM3AQ4G Presentation

Overview

TM3AQ4 (screw) and TM3AQ4G (spring) analog expansion modules:

- 4 channels 12 bits (Voltage, current)
- Removable screw or spring terminal block

Model Name

TM3AQ4 / TM3AQ4G expansion modules may present a **model name**, respectively TM3AQ4-B / TM3AQ4G-B.

NOTE: The **model name** depends on the production site and does not impact the module characteristics.

Main Characteristics

Characteristic		Value
Number of output channels		4 outputs
Rated power supply		24 Vdc
Signal type		Voltage Current
Output range		0...10 Vdc 0...20 mA -10...+10 Vdc 4...20 mA
Resolution		12 bits, or 11 bits + sign
Connection type	TM3AQ4	Removable screw terminal block
	TM3AQ4G	Removable spring terminal block
Cable type and length	Type	Twisted pair shielded
	Length	Maximum 30 m (98 ft)
Weight	TM3AQ4	115 g (4.05 oz)
	TM3AQ4G	100 g (3.52 oz)

Status LEDs

The following figure shows the status LEDs:



The following table describes the status LEDs:

LED	Color	Status	Description
PWR	Green	On	Indicates that TM3 bus power is applied.
		Off	Indicates that TM3 bus power is removed.

TM3AQ4 / TM3AQ4G Characteristics

Introduction

This section provides a description of the output characteristics of the TM3AQ4 / TM3AQ4G expansion modules.

See also Environmental Characteristics, page 20.

⚠ WARNING
<p>UNINTENDED EQUIPMENT OPERATION</p> <p>Do not exceed any of the rated values specified in the environmental and electrical characteristics tables.</p> <p>Failure to follow these instructions can result in death, serious injury, or equipment damage.</p>

Dimensions

The following diagrams show the external dimensions for the TM3AQ4 / TM3AQ4G expansion modules:

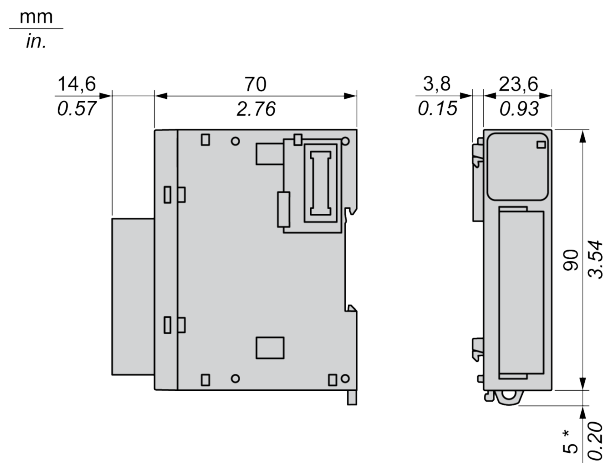

* 8.5 mm (0.33 in) when the clamp is pulled out.

General Characteristics

Characteristics	Value
Rated power supply voltage	24 Vdc
Power supply range	20.4...28.8 Vdc
Connector insertion/removal durability	100 times minimum
Current draw on 5 Vdc internal bus	40 mA (no load) 60 mA (full load)
Current draw on 24 Vdc internal bus	0 mA
Current draw on external 24 Vdc	50 mA (no load) 125 mA (full load)

Output Characteristics

The table below describes the output characteristics of the TM3AQ4 / TM3AQ4G expansion modules:

Characteristics		Value	
		Voltage output	Current output
Software configurable signal type		Voltage output	Current output
Output range		0...10 Vdc -10...+10 Vdc	0...20 mA 4...20 mA
Load impedance		1 k Ω minimum	300 Ω maximum
Application load type		Resistive load	
Settling time		1 ms	
Maximum accuracy at ambient 25 °C (77 °F)		± 0.2 % of full scale	
Temperature drift		± 0.01 % of full scale	
Repeatability after stabilization time		± 0.4 % of full scale	
Nonlinearity		± 0.2 % of full scale	
Output ripple		20 mV maximum	
Overshoot		0 %	
Maximum output deviation		± 1.0 % of full scale	
Resolution		12 bits, or 11 bits + sign (4096 points)	
Input value of LSB		2.44 mV (range 0...10 Vdc) 4.88 mV (range -10...+10 Vdc)	4.88 μ A (range 0...20 mA) 3.91 μ A (range 4...20 mA)
Data type in application program		0...4095 (range 0...10 Vdc) -2048...+2047 (range -10...+10 Vdc)	0...4095
		Scalable from -32768 to 32767	
Input data out of range detection		Yes	
Noise resistance	Maximum temporary deviation during perturbations	± 4 % maximum when EMC perturbation is applied to the power and I/O wiring	
	Cable	Twisted-pair shielded cable	
	Crosstalk	1 LSB maximum	
Isolation	Between external power supply and inputs	1500 Vac	
	Between inputs and internal logic circuits	500 Vac	
Output protection		Short-circuit protection	Open-circuit protection
Behavior when external power is off		The external power supply error status bit in the controller is ON.	

TM3AQ4 / TM3AQ4G Wiring Diagram

Introduction

These expansion modules have a built-in removable screw or spring terminal block for the connection of outputs and power supply.

Wiring Rules

See Wiring Best Practices, page 30.

Wiring Diagram

The following figure illustrates the connection between the outputs, the actuators, and their commons:

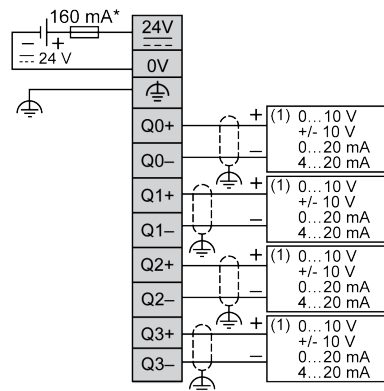

* Type T fuse

(1) Current/Voltage analog input device

TM3 Analog Mixed Input/Output Modules

What's in This Part

TM3AM6 / TM3AM6G Mixed I/O Module 4 Inputs/2 Outputs	83
TM3TM3 / TM3TM3G Mixed I/O Module 2 Inputs/1 Output	89

TM3AM6 / TM3AM6G Mixed I/O Module 4 Inputs/2 Outputs

What's in This Chapter

TM3AM6 / TM3AM6G Presentation 83
 TM3AM6 / TM3AM6G Characteristics 84
 TM3AM6 / TM3AM6G Wiring Diagram 88

Overview

This chapter describes the TM3AM6 / TM3AM6G expansion modules, their characteristics, and their connection to the different sensors and actuators.

TM3AM6 / TM3AM6G Presentation

Overview

TM3AM6 (screw) and TM3AM6G (spring) analog expansion modules:

- 4 input channels 12 bits (Voltage, current)
- 2 output channels 12 bits (Voltage, current)
- Removable screw or spring terminal block

Model Name

TM3AM6 / TM3AM6G expansion modules may present a **model name**, respectively TM3AM6-B / TM3AM6G-B.

NOTE: The **model name** depends on the production site and does not impact the module characteristics.

Main Characteristics

Characteristic		Value			
Number of channels		4 inputs		2 outputs	
Rated power supply		24 Vdc			
Signal type		Voltage	Current	Voltage	Current
Input range		0...10 Vdc	0...20 mA	0...10 Vdc	0...20 mA
		-10...+10 Vdc	4...20 mA	-10...+10 Vdc	4...20 mA
Resolution		12 bits, or 11 bits + sign			
Connection type	TM3AM6	Removable screw terminal block			
	TM3AM6G	Removable spring terminal block			
Cable type and length	Type	Twisted pair shielded			
	Length	Maximum 30 m (98 ft)			
Weight	TM3AM6	110 g (3.88 oz)			
	TM3AM6G	100 g (3.52 oz)			

Status LEDs

The following figure shows the status LEDs:



The following table describes the status LEDs:

LED	Color	Status	Description
PWR	Green	On	Indicates that TM3 bus power is applied.
		Off	Indicates that TM3 bus power is removed.

TM3AM6 / TM3AM6G Characteristics

Introduction

This section provides a description of the electrical, the input/output characteristics of the TM3AM6 / TM3AM6G expansion modules.

See also Environmental Characteristics, page 20.

▲ WARNING
<p>UNINTENDED EQUIPMENT OPERATION</p> <p>Do not exceed any of the rated values specified in the environmental and electrical characteristics tables.</p> <p>Failure to follow these instructions can result in death, serious injury, or equipment damage.</p>

Dimensions

The following diagrams show the external dimensions for the TM3AM6 / TM3AM6G expansion modules:

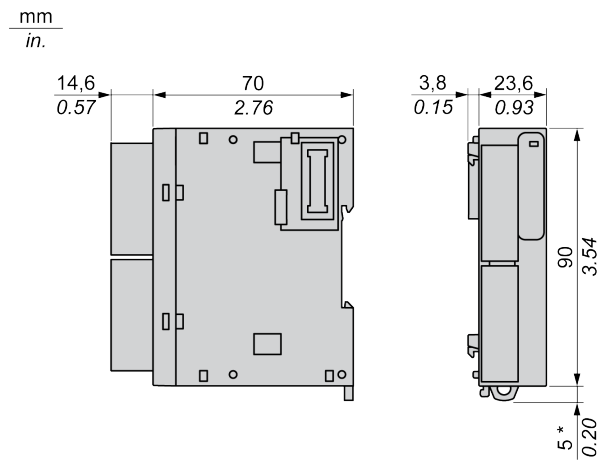

* 8.5 mm (0.33 in) when the clamp is pulled out.

General Characteristics

Characteristics	Value
Rated power supply voltage	24 Vdc
Power supply range	20.4...28.8 Vdc
Connector insertion/removal durability	100 times minimum
Current draw on 5 Vdc internal bus	40 mA (no load) 50 mA (full load)
Current draw on 24 Vdc internal bus	0 mA
Current draw on external 24 Vdc	55 mA (no load) 100 mA (full load)

Input Characteristics

The table below describes the input characteristics of the TM3AM6 / TM3AM6G expansion modules:

Characteristics		Value	
		Voltage input	Current input
Input range		0...10 Vdc -10...+10 Vdc	0...20 mA 4...20 mA
Input impedance		1 M Ω minimum	50 Ω maximum
Sample duration time		Software configurable: 1 ms or 10 ms per channel	
Input type		Single-ended input	
Operating mode		Self-scan	
Conversion mode		Sigma delta ADC	
Maximum accuracy at ambient 25 °C (77 °F)		± 0.2 % of full scale	
Temperature drift		± 0.01 % of full scale	
Repeatability after stabilization time		± 0.5 % of full scale	
Nonlinearity		± 0.2 % of full scale	
Maximum input deviation		± 1.0 % of full scale	
Resolution		12 bits (4096 points)	
Input value of LSB		2.44 mV (range 0...10 Vdc) 4.88 mV (range -10...+10 Vdc)	4.88 μ A (range 0...20 mA) 3.91 μ A (range 4...20 mA)
Data type in application program		Scalable from -32768 to 32767	
Input data out of range detection		Yes	
Noise resistance	Maximum temporary deviation during perturbations	± 4 % maximum when EMC perturbation is applied to the power and I/O wiring	
	Cable	Twisted-pair shielded cable	
	Crosstalk	1 LSB max	
Isolation	Between external power supply and inputs	1500 Vac	
	Between inputs and internal logic circuits	500 Vac	
Maximum continuous allowed overload (no damage)		13 Vdc	40 mA
Input filter		Software filter: 0...10 s (per 0.01 s unit)	
Behavior when external power is off		Input value is 0. The external power supply error status bit in the controller is ON.	

Output Characteristics

The table below describes the output characteristics of the TM3AM6 / TM3AM6G expansion modules:

Characteristics		Value	
		Voltage output	Current output
Software configurable signal type		Voltage output	Current output
Output range		0...10 Vdc -10...+10 Vdc	0...20 mA 4...20 mA
Load impedance		1 kΩ minimum	300 Ω maximum
Application load time		Resistive load	
Settling time		1 ms	
Maximum accuracy at ambient 25 °C (77 °F)		±0.2 % of full scale	
Temperature drift		±0.01 % of full scale	
Repeatability after stabilization time		±0.4 % of full scale	
Nonlinearity		±0.2 % of full scale	
Output ripple		20 mV maximum	
Overshoot		0 %	
Maximum output deviation		±1.0 % of full scale	
Resolution		12 bits (4096 points)	
Input value of LSB		2.44 mV (range 0...10 Vdc) 4.88 mV (range -10...+10 Vdc)	4.88 μA (range 0...20 mA) 3.91 μA (range 4...20 mA)
Data type in application program		0...4095 (range 0...10 Vdc) -2048...+2047 (range -10...+10 Vdc)	0...4095
		Scalable from -32768 to 32767	
Noise resistance	Maximum temporary deviation during perturbations	±4 % maximum when EMC perturbation is applied to the power and I/O wiring	
	Cable	Twisted-pair shielded cable	
	Crosstalk	1 LSB maximum	
Isolation	Between external power supply and inputs	1500 Vac	
	Between inputs and internal logic circuits	500 Vac	
Output protection		Short-circuit protection	Open-circuit protection
Behavior when external power is off		The external power supply error status bit in the controller is ON.	

TM3AM6 / TM3AM6G Wiring Diagram

Introduction

These expansion modules have a built-in removable screw or spring terminal block for the connection of inputs, outputs, and power supply.

NOTE: Loop powered sensors are not supported by these expansion modules. The modules do not provide loop power when wired for current.

Wiring Rules

See Wiring Best Practices, page 30.

Wiring Diagram

The following figure illustrates the connections between the inputs and outputs, the sensors and actuators, and their commons:

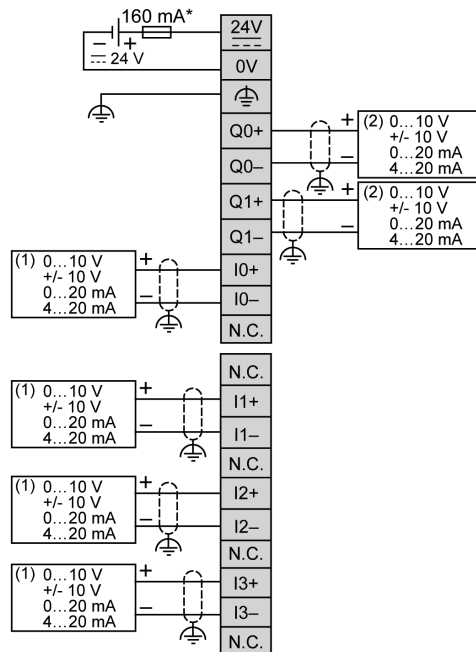

* Type T fuse

(1) Current/Voltage analog output device

(2) Current/Voltage analog input device

⚠ WARNING

UNINTENDED EQUIPMENT OPERATION

Do not connect wires to unused terminals and/or terminals indicated as “No Connection (N.C.)”.

Failure to follow these instructions can result in death, serious injury, or equipment damage.

TM3TM3 / TM3TM3G Mixed I/O Module 2 Inputs/1 Output

What's in This Chapter

TM3TM3 / TM3TM3G Presentation..... 89
 TM3TM3 / TM3TM3G Characteristics 90
 TM3TM3 / TM3TM3G Wiring Diagram 95

Overview

This chapter describes the TM3TM3 / TM3TM3G expansion modules, its characteristics, and its connection to the different sensors and actuators.

TM3TM3 / TM3TM3G Presentation

Overview

- TM3TM3 (screw) and TM3TM3G (spring) analog expansion modules:
- 2 input channels 16 bits (Voltage, current, thermocouple, 3-wire-RTD)
 - 1 output channel 12 bits (Voltage, current)
 - Removable screw or spring terminal block

Main Characteristics

Characteristic		Value					
Number of channels		2 inputs			1 output		
Rated power supply		24 Vdc					
Signal type		Voltage	Current	Thermocouple	3-wire-RTD	Voltage	Current
Input range		0...10 Vdc -10...+10 Vdc	0...20 mA 4...20 mA	Type K, J, R, S, B, E, T, N, C	PT100, PT1000, NI100, NI1000	0...10 Vdc -10...+10 Vdc	0...20 mA 4...20 mA
Resolution max		16 bits, or 15 bits + sign			12 bits (4096 points)		
Connection type	TM3TM3	Removable screw terminal block					
	TM3TM3G	Removable spring terminal block					
Cable type and length	Type	Twisted pair shielded					
	Length	Maximum 30 m (98 ft)					
Weight	TM3TM3	115 g (4.05 oz)					
	TM3TM3G	100 g (3.52 oz)					

Status LEDs

The following figure shows the status LEDs:



The following table describes the status LEDs:

LED	Color	Status	Description
PWR	Green	On	Indicates that TM3 bus power is applied.
		Off	Indicates that TM3 bus power is removed.

TM3TM3 / TM3TM3G Characteristics

Introduction

This section provides a description of the electrical, the input/output characteristics of the TM3TM3 / TM3TM3G expansion modules.

See also Environmental Characteristics, page 20.

⚠ WARNING
UNINTENDED EQUIPMENT OPERATION
Do not exceed any of the rated values specified in the environmental and electrical characteristics tables.
Failure to follow these instructions can result in death, serious injury, or equipment damage.

Dimensions

The following diagrams show the external dimensions for the TM3TM3 / TM3TM3G expansion modules:

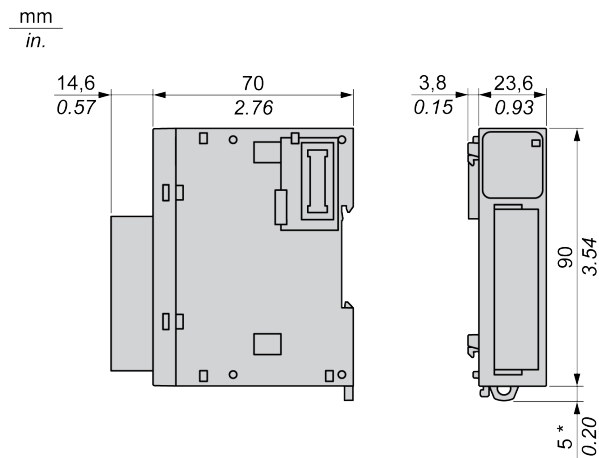

* 8.5 mm (0.33 in) when the clamp is pulled out.

General Characteristics

Characteristics	Value
Rated power supply voltage	24 Vdc
Power supply range	20.4...28.8 Vdc
Connector insertion/removal durability	100 times minimum
Current draw on 5 Vdc internal bus	55 mA (no load) 60 mA (full load)
Current draw on 24 Vdc internal bus	0 mA
Current draw on external 24 Vdc	55 mA (no load) 80 mA (full load)

Input Characteristics

The table below describes the input characteristics of the TM3TM3 / TM3TM3G expansion modules:

Characteristics	Value					
	Voltage input	Current input	Thermocouple type		3-wire-RTD	
Input range	0...10 Vdc -10...+10 Vdc	0...20 mA 4...20 mA	K	-200...1300 °C	PT100	-200...850 °C
				(-328...2372 °F)		(-328...1562 °F)
			J	-200...1000 °C	PT1000	-200...600 °C
				(-328...1832 °F)		(-328...1112 °F)
			R	0...1760	NI100	-60...180 °C
				(32...3200 °F)		(-76...356 °F)
			S	0...1760 °C	NI1000	-60...180 °C
				(32...3200 °F)		(-76...356 °F)
			B	0...1820 °C		
E	-200...800					
T	-200...400 °C					
N	-200...1300					
C	0...2315 °C					
	(32...4199 °F)					
Input impedance	1 MΩ minimum	50 Ω maximum	1 MΩ minimum		1 MΩ minimum	
Sample duration time	Software configurable: 10 ms or 100 ms per enabled channel		100 ms per enabled channel			
Input type	Single-ended input					
Operating mode	Self-scan					
Conversion mode	Sigma delta ADC					
Maximum accuracy at ambient 25 °C (77 °F)	±0.1 % of full scale		±0.1 % of full scale		±0.1 % of full scale	
			Except:			
			R	±6 °C at 0...200 °C		
			S	(±10.8 °F at 32...392 °F)		
B	Not available at 0...300 °C					
		(32...572 °F)				
K	±0.4 % of full scale					
J	under 0 °C (32 °F)					
E						
T						
N						
Temperature drift	±0.006 % of full scale					
Repeatability after stabilization time	±0.5 % of full scale					
Nonlinearity	±0.1 % of full scale					

Characteristics	Value					
	Voltage input	Current input	Thermocouple type	3-wire-RTD		
Maximum input deviation	±1.0 % of full scale					
Resolution	16 bits, or 15 bits + sign (65536 points)		K	15000 points	PT100	10500 points
			J	12000 points	PT1000	8000 points
			R	17600 points	NI100	2400 points
			S	17600 points	NI1000	2400 points
			B	18200 points		
			E	10000 points		
			T	6000 points		
			N	15000 points		
			C	23150 points		
Input value of LSB	0.153 mV (range 0...10 Vdc) 0.305 mV (range –10...+10 Vdc)	0.305 µA (range 0...20 mA) 0.244 µA (range 4...20 mA)	0.1 °C (0.18 °F)			
Data type in application program	Scalable from –32768 to 32767					
Input data out of range detection	Yes					
Noise resistance	Maximum temporary deviation during perturbations	±4 % maximum when EMC perturbation is applied to the power and I/O wiring				
	Cable	Twisted-pair shielded cable				
	Crosstalk	1 LSB maximum				
Isolation	Between external power supply and inputs	1500 Vac				
	Between inputs and internal logic circuits	500 Vac				
Maximum continuous allowed overload (no damage)	13 Vdc	40 mA	N/A			
Input filter	Software filter: 0...10 s (per 0.01 s unit)					
Behavior when temperature sensor is broken	N/A		Input value is highest limit value. Highest limit flag is ON.			
Behavior when external power is off	Input value is 0.		Input value is highest limit value.			
	The external power supply error status bit in the controller is ON.					

Output Characteristics

The table below describes the output characteristics of the TM3TM3 / TM3TM3G expansion modules:

Characteristics		Value	
		Voltage output	Current output
Software configurable signal type		Voltage output	Current output
Output range		0...10 Vdc -10...+10 Vdc	0...20 mA 4...20 mA
Load impedance		1 k Ω minimum	300 Ω maximum
Application load time		Resistive load	
Settling time		1 ms	
Maximum accuracy at ambient 25 °C (77 °F)		± 0.1 % of full scale	
Temperature drift		± 0.006 % of full scale	
Repeatability after stabilization time		± 0.4 % of full scale	
Nonlinearity		± 0.01 % of full scale	
Output ripple		20 mV maximum	
Overshoot		0 %	
Maximum output deviation		± 1.0 % of full scale	
Resolution		12 bits (4096 points)	
Input value of LSB		2.44 mV (range 0...10 Vdc) 4.88 mV (range -10...+10 Vdc)	4.88 μ A (range 0...20 mA) 3.91 μ A (range 4...20 mA)
Data type in application program		0...4095 (range 0...10 Vdc) -2048...+2047 (range -10...+10 Vdc)	0...4095
		Scalable from -32768 to 32767	
Noise resistance	Maximum temporary deviation during perturbations	± 4 % maximum when EMC perturbation is applied to the power and I/O wiring	
	Cable	Twisted-pair shielded cable	
	Crosstalk	1 LSB maximum	
Isolation	Between external power supply and inputs	1500 Vac	
	Between inputs and internal logic circuits	500 Vac	
Output protection		Short-circuit protection	Open-circuit protection
Behavior when external power is off		The external power supply error status bit in the controller is ON.	

TM3TM3 / TM3TM3G Wiring Diagram

Introduction

These expansion modules have a built-in removable screw or spring terminal block for the connection of inputs, outputs, and power supply.

Wiring Rules

See Wiring Best Practices, page 30.

Wiring Diagram

The following figure illustrates the connections between the inputs and outputs, the sensors and actuators, and their commons:

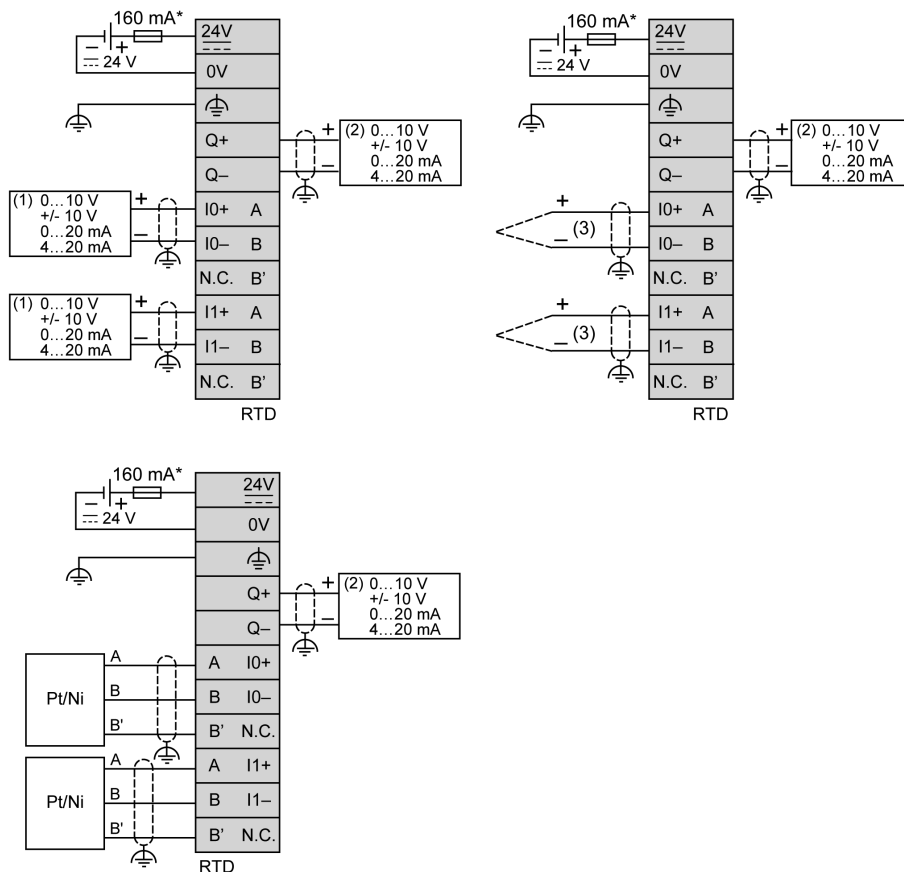

* Type T fuse

- (1) Current/Voltage analog output device
- (2) Current/Voltage analog input device
- (3) Thermocouple

▲ WARNING**UNINTENDED EQUIPMENT OPERATION**

Do not connect wires to unused terminals and/or terminals indicated as “No Connection (N.C.)”.

Failure to follow these instructions can result in death, serious injury, or equipment damage.

Glossary

A

application:

A program including configuration data, symbols, and documentation.

C

controller:

Automates industrial processes (also known as programmable logic controller or programmable controller).

E

EIA rack:

(*electronic industries alliance rack*) A standardized (EIA 310-D, IEC 60297, and DIN 41494 SC48D) system for mounting various electronic modules in a stack or rack that is 19 inches (482.6 mm) wide.

EN:

EN identifies one of many European standards maintained by CEN (*European Committee for Standardization*), CENELEC (*European Committee for Electrotechnical Standardization*), or ETSI (*European Telecommunications Standards Institute*).

expansion bus:

An electronic communication bus between expansion I/O modules and a controller or bus coupler.

expansion connector:

A connector to attach expansion I/O modules.

H

HE10:

Rectangular connector for electrical signals with frequencies below 3 MHz, complying with IEC 60807-2.

I

I/O:

(*input/output*)

IEC:

(*international electrotechnical commission*) A non-profit and non-governmental international standards organization that prepares and publishes international standards for electrical, electronic, and related technologies.

IP 20:

(*ingress protection*) The protection classification according to IEC 60529 offered by an enclosure, shown by the letter IP and 2 digits. The first digit indicates 2 factors: helping protect persons and for equipment. The second digit indicates helping protect against water. IP 20 devices help protect against electric contact of objects larger than 12.5 mm, but not against water.

N

NEMA:

(national electrical manufacturers association) The standard for the performance of various classes of electrical enclosures. The NEMA standards cover corrosion resistance, ability to help protect from rain, submersion, and so on. For IEC member countries, the IEC 60529 standard classifies the ingress protection rating for enclosures.

P

program:

The component of an application that consists of compiled source code capable of being installed in the memory of a logic controller.

R

RJ45:

A standard type of 8-pin connector for network cables defined for Ethernet.

T

terminal block:

(terminal block) The component that mounts in an electronic module and provides electrical connections between the controller and the field devices.

Index

A

accessories	19
assembling to a controller	27

C

certifications and standards	22
characteristics	
TM3AI2H / TM3AI2HG	39
TM3AI4 / TM3AI4G	44
TM3AI8 / TM3AI8G	49
TM3AM6 / TM3AM6G	84
TM3AQ2 / TM3AQ2G	73
TM3AQ4 / TM3AQ4G	78
TM3TI4 / TM3TI4G	54
TM3TI4D / TM3TI4DG	60
TM3TI8T / TM3TI8TG	66
TM3TM3 / TM3TM3G	90
controllers	
disassembling a module	29

D

DIN rail	26
----------------	----

E

electromagnetic susceptibility	22
environmental characteristics	20

G

general description	14
grounding	34

I

intended use	6
--------------------	---

M

minimum clearances	24
mounting position	24

P

physical description	
TM3 I/O expansion modules	18
power supply	33
presentation	
TM3AI2H / TM3AI2HG	38
TM3AI4 / TM3AI4G	43
TM3AI8 / TM3AI8G	48
TM3AM6 / TM3AM6G	83
TM3AQ2 / TM3AQ2G	72
TM3AQ4 / TM3AQ4G	77
TM3TI4 / TM3TI4G	53
TM3TI4D / TM3TI4DG	59
TM3TI8T / TM3TI8TG	65
TM3TM3 / TM3TM3G	89

Q

qualification of personnel	5
----------------------------------	---

T

TM3 analog I/O expansion modules	
TM3AI2H / TM3AI2HG	38
TM3AI4 / TM3AI4G	43
TM3AI8 / TM3AI8G	48
TM3AM6 / TM3AM6G	83
TM3AQ2 / TM3AQ2G	72
TM3AQ4 / TM3AQ4G	77
TM3TI4 / TM3TI4G	53
TM3TI4D / TM3TI4DG	59
TM3TI8T / TM3TI8TG	65
TM3TM3 / TM3TM3G	89
TM3 I/O expansion modules	
physical description	18
TM3AI2H / TM3AI2HG	
characteristics	39
presentation	38
wiring diagram	42
TM3AI4 / TM3AI4G	
characteristics	44
presentation	43
wiring diagram	47
TM3AI8 / TM3AI8G	
characteristics	49
presentation	48
wiring diagram	52
TM3AM6 / TM3AM6G	
characteristics	84
presentation	83
wiring diagram	88
TM3AQ2 / TM3AQ2G	
characteristics	73
presentation	72
wiring diagram	76
TM3AQ4 / TM3AQ4G	
characteristics	78
presentation	77
wiring diagram	81
TM3TI4 / TM3TI4G	
characteristics	54
presentation	53
wiring diagram	58
TM3TI4D / TM3TI4DG	
characteristics	60
presentation	59
wiring diagram	64
TM3TI8T / TM3TI8TG	
characteristics	66
presentation	65
wiring diagram	70
TM3TM3 / TM3TM3G	
characteristics	90
presentation	89
wiring diagram	95

W

wiring diagram	
TM3AI2H / TM3AI2HG	42
TM3AI4 / TM3AI4G	47
TM3AI8 / TM3AI8G	52
TM3AM6 / TM3AM6G	88
TM3AQ2 / TM3AQ2G	76
TM3AQ4 / TM3AQ4G	81

TM3TI4 / TM3TI4G.....	58
TM3TI4D / TM3TI4DG.....	64
TM3TI8T / TM3TI8TG	70
TM3TM3 / TM3TM3G.....	95
wiring rules	30

Schneider Electric
35 rue Joseph Monier
92500 Rueil Malmaison
France

+ 33 (0) 1 41 29 70 00

www.se.com

As standards, specifications, and design change from time to time,
please ask for confirmation of the information given in this publication.

© 2024 Schneider Electric. All rights reserved.

EIO0000003131.04