

Lexium™ T Robot

Hardware Guide

Original instructions

EIO0000002280.05

04/2025

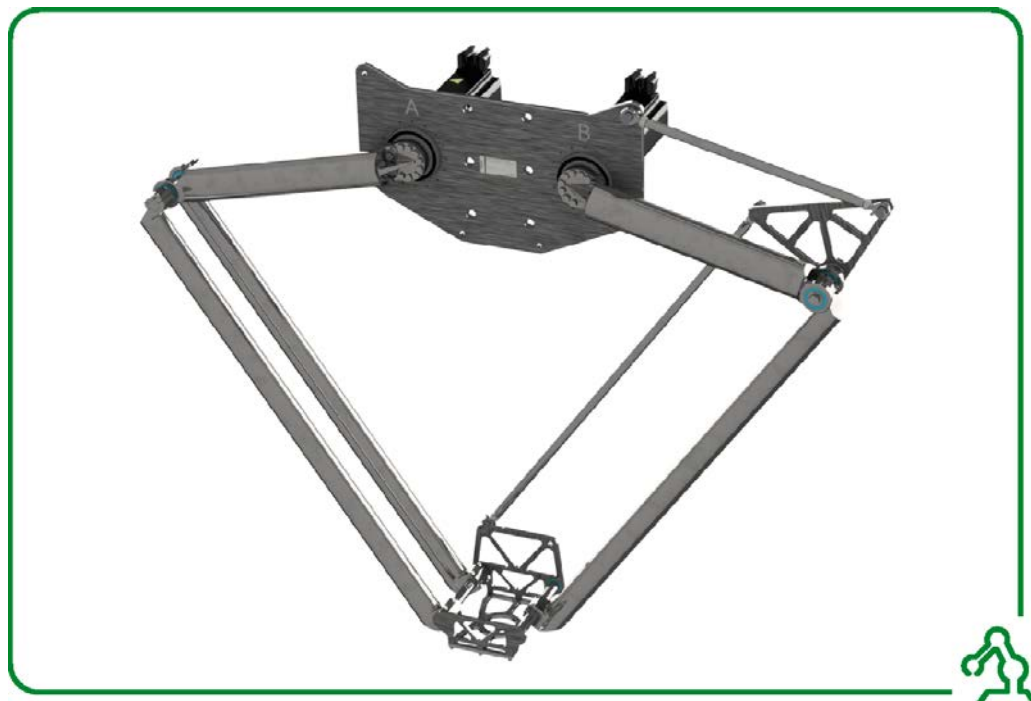

Legal Information

The information provided in this document contains general descriptions, technical characteristics and/or recommendations related to products/solutions.

This document is not intended as a substitute for a detailed study or operational and site-specific development or schematic plan. It is not to be used for determining suitability or reliability of the products/solutions for specific user applications. It is the duty of any such user to perform or have any professional expert of its choice (integrator, specifier or the like) perform the appropriate and comprehensive risk analysis, evaluation and testing of the products/solutions with respect to the relevant specific application or use thereof.

The Schneider Electric brand and any trademarks of Schneider Electric SE and its subsidiaries referred to in this document are the property of Schneider Electric SE or its subsidiaries. All other brands may be trademarks of their respective owner.

This document and its content are protected under applicable copyright laws and provided for informative use only. No part of this document may be reproduced or transmitted in any form or by any means (electronic, mechanical, photocopying, recording, or otherwise), for any purpose, without the prior written permission of Schneider Electric.

Schneider Electric does not grant any right or license for commercial use of the document or its content, except for a non-exclusive and personal license to consult it on an "as is" basis.

Schneider Electric reserves the right to make changes or updates with respect to or in the content of this document or the format thereof, at any time without notice.

To the extent permitted by applicable law, no responsibility or liability is assumed by Schneider Electric and its subsidiaries for any errors or omissions in the informational content of this document, as well as any non-intended use or misuse of the content thereof.

Table of Contents

Safety Information	5
About the Book.....	6
Hazard Information	12
Proper Use.....	12
Qualification of Personnel.....	15
Residual Risks.....	16
System Overview	24
System Architecture.....	24
Product Overview	25
Type Code.....	28
Type Plate	29
Technical Data	30
Ambient Conditions.....	30
Mechanical and Electrical Data of Lexium T Robots.....	32
Robot VRKT1•••NC	32
Robot VRKT2•••NC	33
Robot VRKT3•••NC	34
Robot VRKT5•••NC	35
Dimensional Drawings.....	36
Dimensional Drawing of the Lexium T Robot	36
Detail Drawing of the Main Body.....	39
Detail Drawing of the Upper Arm	43
Detail Drawing of the Lower Arm	44
Detail Drawing of the Parallel Plate	45
Detail Drawing of the Lever Parallel Linkage.....	47
Electrical Connections.....	48
Performance Data.....	50
Typical Cycle Time	50
Load Capacity Diagram	57
Design of the Robot Frame.....	59
Run-On Motions of the Robot for Risk Analysis	61
Technical Data of the Motor and the Gearbox.....	69
Transport and Commissioning	71
Transport and Unpacking	71
Transport and Storage.....	71
Unpacking	72
Mechanical Installation.....	75
Information About Installation	75
Mounting the Robot.....	76
Electrical Installation	79
Cabling the VRKT•M••NC	79
Cabling the VRKT•L••NC	82
Initial Start-Up.....	84
Allocation of the Sercos Addresses.....	84
Parametrization of the Robot Mechanics	84
Mounting the Lower Arms with Parallel Plate	85
Mounting the Rods for the Parallel Linkage	87
Setting the Monitoring.....	88

Verifying the Installation	89
Start-Up	91
Mounting the Payload.....	92
Mounting the Gripper.....	92
Mounting a Rotational Drive Unit	94
Supply of the Gripper.....	95
Maintenance and Repair	96
Maintenance, Repair, and Cleaning.....	96
General Information About Maintenance, Repair, and Cleaning.....	96
Maintenance Plan	98
Maintaining the Upper Arm Bearings.....	99
Maintaining the Parallel Plate Bearings	100
Maintaining the Parallel Rod System.....	101
Maintaining the Motor (Optional Equipment).....	102
Maintaining the Gearbox.....	102
Cleaning.....	103
Repairing After Collisions.....	104
Replacing Parts	105
Information About Replacing Parts	105
Replacing the Lower Arms	106
Replacing the Parallel Plate	107
Replacing the Parallel Plate Bearings	108
Replacing the Parallel Rods	110
Replacing the Upper Arms	111
Replacing the Protector Cap	113
Replacing the Motor or the Gearbox on the Main Axis	114
Calibration.....	118
Calibration of the Robot Mechanics	118
Calibrating the Main Axes	119
Replacement Equipment and Accessories.....	120
Replacement Equipment Inventory.....	120
Replacement Equipment of the Lexium T Robots	122
Troubleshooting	125
Appendices	126
Further Information About the Manufacturer.....	127
Contact Addresses.....	127
Product Training Courses	127
Disposal	128
Declaration of Incorporation.....	129
Index	131

Safety Information

Important Information

Read these instructions carefully, and look at the equipment to become familiar with the device before trying to install, operate, service, or maintain it. The following special messages may appear throughout this documentation or on the equipment to warn of potential hazards or to call attention to information that clarifies or simplifies a procedure.





The addition of this symbol to a “Danger” or “Warning” safety label indicates that an electrical hazard exists which will result in personal injury if the instructions are not followed.



This is the safety alert symbol. It is used to alert you to potential personal injury hazards. Obey all safety messages that follow this symbol to avoid possible injury or death.

 DANGER
DANGER indicates a hazardous situation which, if not avoided, will result in death or serious injury.

 WARNING
WARNING indicates a hazardous situation which, if not avoided, could result in death or serious injury.

 CAUTION
CAUTION indicates a hazardous situation which, if not avoided, could result in minor or moderate injury.

NOTICE
NOTICE is used to address practices not related to physical injury.

Please Note

Electrical equipment should be installed, operated, serviced, and maintained only by qualified personnel. No responsibility is assumed by Schneider Electric for any consequences arising out of the use of this material.

A qualified person is one who has skills and knowledge related to the construction and operation of electrical equipment and its installation, and has received safety training to recognize and avoid the hazards involved.

About the Book

Document Scope

This manual is to help you use the capabilities of the robot safely and properly.

Follow the instructions within this manual to help:

- Reduce risks
- Reduce repair costs and downtime of the robot
- Increase the service life of the robot
- Increase the reliability of the robot

Validity Note

For more information on the validity of the present document, see the online help for the product.

The characteristics of the products described in this document are intended to match the characteristics that are available on www.se.com. As part of our corporate strategy for constant improvement, we may revise the content over time to enhance clarity and accuracy. If you see a difference between the characteristics in this document and the characteristics on www.se.com, consider www.se.com to contain the latest information.

Product Related Information

The equipment described herein must be used in accordance with the application-specific risk analysis that you are to perform along with verification of all applicable standards. Pay attention in conforming to any safety information, different electrical requirements, and normative standards that would apply to your application of the information contained in the present manual and the manuals for associated equipment.

⚠️ DANGER**ELECTRIC SHOCK, EXPLOSION, OR ARC FLASH**

- Disconnect all power from all equipment including connected devices prior to removing any covers or doors, or installing or removing any accessories, hardware, cables, or wires except under the specific conditions specified in the appropriate hardware guide for this equipment.
- Always use a properly rated voltage sensing device to confirm that the power is off where and when indicated.
- Replace and secure all covers, accessories, hardware, cables, and wires and confirm that a proper ground connection exists before applying power to the equipment.
- Use only the specified voltage when operating this equipment and any associated products.
- After switching off the equipment make sure to maintain a waiting time of at least 15 minutes before disconnecting the power cable for the capacitors to discharge.
- Operate electrical components only with a connected protective ground (earth) cable.
- Verify the secure connection of the protective ground (earth) cable to the electrical devices so that connection complies with the wiring diagram.
- Do not touch the electrical connection points of the components when the equipment is energized.
- Provide protection against indirect contact.
- Insulate any unused conductors on both ends of the connection cable.
- Ensure that the power cables are correctly connected and connectors are locked in place during the operation time of the system.

Failure to follow these instructions will result in death or serious injury.

⚠️ WARNING**UNINTENDED EQUIPMENT OPERATION**

- Use appropriate protective devices (functional safety devices) in compliance with local and national standards.
- Perform a hazard and risk analysis to determine the appropriate safety integrity level, and any other safety requirements, for your specific application based on all the applicable standards.
- Ensure that the hazard and risk analysis is conducted and respected according to EN/ISO 12100 during the design of your machine.
- Apply all measures from the hazard and risk analysis before putting the system in service.
- Install and operate the device only in the intended environment considering the residual risks.

Failure to follow these instructions can result in death, serious injury, or equipment damage.

▲ WARNING**LOSS OF CONTROL**

- Perform a Failure Mode and Effects Analysis (FMEA), or equivalent risk analysis, of your application, and apply preventive and detective controls before implementation.
- Provide a fallback state for undesired control events or sequences.
- Provide separate or redundant control paths wherever required.
- Supply appropriate parameters, particularly for limits.
- Review the implications of transmission delays and take actions to mitigate them.
- Review the implications of communication link interruptions and take actions to mitigate them.
- Provide independent paths for control functions (for example, emergency stop, over-limit conditions, and error conditions) according to your risk assessment, and applicable codes and regulations.
- Apply local accident prevention and safety regulations and guidelines.¹
- Test each implementation of a system for proper operation before placing it into service.

Failure to follow these instructions can result in death, serious injury, or equipment damage.

¹ For additional information, refer to NEMA ICS 1.1 (latest edition), *Safety Guidelines for the Application, Installation, and Maintenance of Solid State Control* and to NEMA ICS 7.1 (latest edition), *Safety Standards for Construction and Guide for Selection, Installation and Operation of Adjustable-Speed Drive Systems* or their equivalent governing your particular location.

▲ WARNING**UNINTENDED EQUIPMENT OPERATION**

- Only use software, firmware and hardware components approved by Schneider Electric for use with this equipment.
- Update your application program every time you change the physical hardware configuration.
- Validate and test your system every time you apply safety-related or non-safety-related modifications to your application program or modify the physical hardware configuration.

Failure to follow these instructions can result in death, serious injury, or equipment damage.

General Cybersecurity Information

In recent years, the growing number of networked machines and production plants has seen a corresponding increase in the potential for cyber threats, such as unauthorized access, data breaches, and operational disruptions. You must, therefore, consider all possible cybersecurity measures to help protect assets and systems against such threats.

To help keep your Schneider Electric products secure and protected, it is in your best interest to implement the cybersecurity best practices as described in the [Cybersecurity Best Practices](#) document.

Schneider Electric provides additional information and assistance:

- [Subscribe to the Schneider Electric security newsletter.](#)
- [Visit the Cybersecurity Support Portal web page to:](#)
 - [Find Security Notifications.](#)
 - [Report vulnerabilities and incidents.](#)
- [Visit the Schneider Electric Cybersecurity and Data Protection Posture web page to:](#)
 - [Access the cybersecurity posture.](#)
 - [Learn more about cybersecurity in the cybersecurity academy.](#)
 - [Explore the cybersecurity services from Schneider Electric.](#)

Environmental Data

For product compliance and environmental information, refer to the [Schneider Electric Environmental Data Program](#).

Related Documents

Title of Documentation	Reference Number
Lexium T Robot VRKT....., Instruction Sheet	NAT24232 (EN, DE, IT, FR, ES, ZH)
MH3 Servo motor Motor Manual	0198441114042 (EN) 0198441114041 (GER)
Lexium 52 Hardware Guide	EIO0000001347 (EN) EIO0000001348 (GER)
Lexium 62 Hardware Guide	EIO0000001349 (EN) EIO0000001350 (GER)
Lexium 62 ILM Hardware Guide	EIO0000001351 (EN) EIO0000001352 (GER)
SchneiderElectricRobotics Library Guide (only available in the online help)	EIO0000002236 (EN)
RoboticModule Library Guide (only available in the online help)	EIO0000002234 (EN)
Cybersecurity Guidelines for EcoStruxure Machine Expert, Modicon and PacDrive Controllers and Associated Equipment, User Guide	EIO0000004242 (EN)
Cybersecurity Best Practices	CS-Best-Practices-2019-340 (EN)

To find documents online, visit the Schneider Electric download center (www.se.com/ww/en/download/).

Information on Non-Inclusive or Insensitive Terminology

As a responsible, inclusive company, Schneider Electric is constantly updating its communications and products that contain non-inclusive or insensitive terminology. However, despite these efforts, our content may still contain terms that are deemed inappropriate by some customers.

Terminology Derived from Standards

The technical terms, terminology, symbols and the corresponding descriptions in the information contained herein, or that appear in or on the products themselves, are generally derived from the terms or definitions of international standards.

In the area of functional safety systems, drives and general automation, this may include, but is not limited to, terms such as *safety*, *safety function*, *safe state*, *fault*, *fault reset*, *malfunction*, *failure*, *error*, *error message*, *dangerous*, etc.

Among others, these standards include:

Standard	Description
IEC 61131-2:2007	Programmable controllers, part 2: Equipment requirements and tests.
ISO 13849-1:2023	Safety of machinery: Safety related parts of control systems. General principles for design.
EN 61496-1:2020	Safety of machinery: Electro-sensitive protective equipment. Part 1: General requirements and tests.
ISO 12100:2010	Safety of machinery - General principles for design - Risk assessment and risk reduction
EN 60204-1:2006	Safety of machinery - Electrical equipment of machines - Part 1: General requirements
ISO 14119:2013	Safety of machinery - Interlocking devices associated with guards - Principles for design and selection
ISO 13850:2015	Safety of machinery - Emergency stop - Principles for design
IEC 62061:2021	Safety of machinery - Functional safety of safety-related electrical, electronic, and electronic programmable control systems
IEC 61508-1:2010	Functional safety of electrical/electronic/programmable electronic safety-related systems: General requirements.
IEC 61508-2:2010	Functional safety of electrical/electronic/programmable electronic safety-related systems: Requirements for electrical/electronic/programmable electronic safety-related systems.
IEC 61508-3:2010	Functional safety of electrical/electronic/programmable electronic safety-related systems: Software requirements.
IEC 61784-3:2021	Industrial communication networks - Profiles - Part 3: Functional safety fieldbuses - General rules and profile definitions.
2006/42/EC	Machinery Directive
2014/30/EU	Electromagnetic Compatibility Directive
2014/35/EU	Low Voltage Directive

In addition, terms used in the present document may tangentially be used as they are derived from other standards such as:

Standard	Description
IEC 60034 series	Rotating electrical machines
IEC 61800 series	Adjustable speed electrical power drive systems
IEC 61158 series	Digital data communications for measurement and control – Fieldbus for use in industrial control systems

Finally, the term *zone of operation* may be used in conjunction with the description of specific hazards, and is defined as it is for a *hazard zone* or *danger zone* in the *Machinery Directive (2006/42/EC)* and *ISO 12100:2010*.

NOTE: The aforementioned standards may or may not apply to the specific products cited in the present documentation. For more information concerning the individual standards applicable to the products described herein, see the characteristics tables for those product references.

Figures

Unless otherwise stated, the different robot types and variants of the Lexium T robots are represented in the figures by the robot type VRKT5.

Dual Dimensions

Dimensions are indicated in metric system and U.S. customary units system. The U.S. dimensions are given in parentheses, for example 8.4 mm (0.33 in).

NOTE: The given values in parentheses are rounded and for reference only.

Hazard Information

What's in This Chapter

Proper Use	12
Qualification of Personnel	15
Residual Risks	16

Proper Use

Overview

This section contains information regarding the operation of the Lexium T robot. Qualified personnel, page 15, working with the robot must read and observe this information.

Installation

The robot is intended to be integrated into a machine or assembled with other components to build up a machine or system. The robot is an open type robot that is intended to be installed into an enclosure to provide access protection.

The robot is fast moving equipment. You must ensure that the personnel programming, operating, maintaining, or repairing the robot or machine has undergone all necessary training and able to demonstrate the competence required to carry out these tasks.

▲ WARNING

MOVING PARTS OF THE ROBOT

- Comply with the specified operating conditions and all safety standards concerning robot-based applications.
- Inform operators of the hazards involved in robot-based applications.

Failure to follow these instructions can result in death, serious injury, or equipment damage.

Provide for Protective Measures

Before installing the robot, provide appropriate protective devices in compliance with local and national standards. Do not commission components without appropriate protective devices. After installation, commissioning, or repair, test the protective devices used.

Other standards are applicable as guideline for a robot integration into the machine such as (non exhaustive list):

- Directive 2006/42/EC on machinery
- Standard ISO 10218-1:2011 Robots and robotic devices - Safety requirements for industrial robots - Part 1: Robots
- Standard ISO 10218-2:2011 Robots and robotic devices - Safety requirements for industrial robots - Part 2: Robot systems and integration
- Standard ISO 13857:2019 Safety of machinery - Safety distances to prevent hazard zones being reached by upper and lower limbs
- Standard ISO 14120:2015 Safety of machinery - Guards - General requirements for the design and construction of fixed and movable guards

- Standard EN 349:2017 Safety of machinery - Minimum gaps to avoid crushing of parts of the human body
- Standard ISO 13855:2010 Safety of machinery - Positioning of safeguards with respect to the approach speeds of parts of the human body
- Standard NFPA 79 Electrical Standard for Industrial Machinery
- Standard UL 1740 Standard for Robots and Robotic Equipment
- Standard UL 2011 Standard for Factory Automation Equipment

Perform a risk evaluation concerning the specific use before operating the robot and take appropriate security measures.

▲ WARNING
<p>UNINTENDED EQUIPMENT OPERATION</p> <ul style="list-style-type: none"> • Use appropriate protective devices (functional safety devices) in compliance with local and national standards. • Ensure that a risk assessment is conducted and respected according to EN/ISO 12100 during the design of your machine. • Apply all measures from the hazard and risk analysis before putting the system in operation for the first time. <p>Failure to follow these instructions can result in death, serious injury, or equipment damage.</p>

If circumstances occur that affect the safety or cause changes to the operating behavior of the robot, then immediately shut down the robot and contact your local Schneider Electric service representative.

Use Original Equipment Only

Use only the accessories and mounting parts specified in the documentation and only third-party devices or components that have been expressly approved by Schneider Electric. Only modify the robot in the manner intended and described in this documentation, and other documentation concerning any other associated equipment.

▲ WARNING
<p>UNINTENDED EQUIPMENT OPERATION</p> <ul style="list-style-type: none"> • Only use software, firmware and hardware components approved by Schneider Electric for use with this equipment. • Update your application program every time you change the physical hardware configuration. • Validate and test your system every time you apply safety-related or non-safety-related modifications to your application program or modify the physical hardware configuration. <p>Failure to follow these instructions can result in death, serious injury, or equipment damage.</p>

Misuse

The robot is not suitable for the manipulation of living organisms or explosive materials, nor is it suitable for impact movement.

Incompatible Environments

The components must not be used in the following environments:

- Hazardous (explosive) atmospheres
- Mobile, movable, or floating systems
- Life support systems
- Domestic appliances
- Underground
- Highly saline environments (refer to *Technical Data*, page 30 for materials used)
- Environments with increased radioactive radiation

This equipment has been designed to operate outside of any hazardous location. Only install this equipment in zones known to be free of a hazardous atmosphere.

⚠ DANGER

POTENTIAL FOR EXPLOSION

Install and use this equipment in non-hazardous locations only.

Failure to follow these instructions will result in death or serious injury.

Installation and Operating Conditions

The operating conditions at the installation location must be inspected and maintained in accordance with the required technical data (performance data and ambient conditions). Commissioning is prohibited until the usable machine or system in which the robot is installed is in accordance to the applicable local regulations and standards.

⚠ WARNING

UNINTENDED EQUIPMENT OPERATION

Only use the components in accordance with the installation and operating conditions described in this documentation and other supporting documentation and standards.

Failure to follow these instructions can result in death, serious injury, or equipment damage.

Qualification of Personnel

Target Audience for This Manual

This documentation is intended for users having the following knowledge:

- Advanced knowledge in mechanical engineering
- Advanced knowledge in electrical engineering
- Knowledge of the design of the machine/process in which it is intended

Qualified Person

Aside from skills and knowledge, qualified personnel must be able to detect possible hazards that may arise from parametrization, changing parameter values and generally from mechanical, electrical, or electronic equipment. The qualified personnel must be familiar with the standards, provisions, and regulations for the prevention of industrial accidents, which they must observe when working on the system.

Residual Risks

Overview

Risks arising from the robot have been reduced. However a residual risk remains since the robot is moved and operated with electrical voltage and electrical currents.

If activities involve residual risks, a safety message is made at the appropriate points. This includes potential hazards that may arise, their possible consequences, and describes preventive measures to avoid the hazards.

Electrical Parts

DANGER

ELECTRIC SHOCK, EXPLOSION, OR ARC FLASH

- Disconnect all power from all equipment including connected devices prior to removing any covers or doors, or installing or removing any accessories, hardware, cables, or wires except under the specific conditions specified in the appropriate hardware guide for this equipment.
- Always use a properly rated voltage sensing device to confirm that the power is off where and when indicated.
- Replace and secure all covers, accessories, hardware, cables, and wires and confirm that a proper ground connection exists before applying power to the equipment.
- Use only the specified voltage when operating this equipment and any associated products.
- After switching off the equipment make sure to maintain a waiting time of at least 15 minutes before disconnecting the power cable for the capacitors to discharge.
- Operate electrical components only with a connected protective ground (earth) cable.
- Verify the secure connection of the protective ground (earth) cable to the electrical devices so that connection complies with the wiring diagram.
- Do not touch the electrical connection points of the components when the equipment is energized.
- Provide protection against indirect contact.
- Insulate any unused conductors on both ends of the connection cable.
- Ensure that the power cables are correctly connected and connectors are locked in place during the operation time of the system.

Failure to follow these instructions will result in death or serious injury.

Emergency Stop

The robot mechanics, apart from the motor, are not supplied with brakes nor an emergency stop switch to engage any brakes.

▲ WARNING**ENTRAPMENT BY ROBOT MECHANICS**

- Provide means for ensuring that the motors can be put into a voltage-free state with any internal holding brake or external service brake released.
- Make available those means to allow one person to manually move the robot within reach of the zone of operation.

Failure to follow these instructions can result in death, serious injury, or equipment damage.

The opening of the motor holding brakes may cause the robot to sag.

▲ WARNING**SAGGING OF THE ROBOT**

Ensure that the release of the motor brakes poses no subsequent risks in the zone of operation.

Failure to follow these instructions can result in death, serious injury, or equipment damage.

NOTE: Provide separation devices for all infeed energies. It must be possible to secure the separation devices in de-energized position, for example, by locking.

Assembly and Handling

▲ WARNING**CRUSHING, SHEARING, CUTTING AND HITTING DURING HANDLING**

- Observe the general construction and safety regulations for handling and assembly.
- Use appropriate mounting and transport equipment and use appropriate tools.
- Prevent clamping and crushing by taking appropriate precautions.
- Cover edges and angles to protect against cutting damage.
- Wear suitable protective clothing (for example, protective goggles, protective boots, protective gloves).

Failure to follow these instructions can result in death, serious injury, or equipment damage.

Installation

▲ WARNING**UNINTENDED EQUIPMENT OPERATION**

- Ensure that the robot and the end-effector are properly attached to one another.
- Verify that the settings are correct for the robot installation position, the payload mounted on the Tool Center Point (TCP), and the TCP offset according to the instructions in the present document and any supporting documents.

Failure to follow these instructions can result in death, serious injury, or equipment damage.

Robot Motion

Parts of the mechanics can move at high speeds. In such cases, the payload weight, additionally installed gripper, and shifts in the center of gravity of the moving parts contribute to the total energy of the forces generated.

Motion sequences can occur when operating with robot mechanics, which could allow operational staff to make misjudgments. For safety considerations (according to EN ISO 13849-1), consider the controller and the brakes as non-safety-related elements. Ensure that necessary protective measures are implemented.

The safety standards and directives for the respective country where the equipment is in use define which protective measures are appropriate. Additionally, the system engineer who is responsible for the integration of the robot mechanics must evaluate which measures have to be taken.

NOTE: The configuration of the robot mechanics, the Tool Center Point (TCP) velocity, as well as the additional payload have an effect on the total energy, which can potentially be a source of damage and injury.

WARNING

CRUSHING, SHEARING, CUTTING AND IMPACT INJURY

- The robot must be operated only within an enclosure.
- Open or enter the enclosure for cleaning and maintenance purposes only.
- Design the enclosure to withstand an impact from the robot and to resist ejected parts from escaping the zone of operation.
- Design the enclosure to safely deactivate the robot as soon as a person enters the zone of operation of the robot.
- All barriers, protective doors, contact mats, light barriers, and other protective equipment, must be configured correctly and enabled whenever the robot mechanics are under power.
- Define the clearance distance to the zone of operation of the robot so the operational staff do not have access to, nor can be enclosed in, the robot mechanics zone of operation.
- Design the enclosure to account for the maximum possible travel paths of the robot; that is, the maximum path until the hardware safety system limits as well as the additional run-on paths, in case of a power interruption.

Failure to follow these instructions can result in death, serious injury, or equipment damage.

For detailed information about travel path and power loss, refer to *Run-on Motions of the Robot for Risk Analysis*, page 61.

Hot Surfaces

The metal surfaces of the robot may exceed 70 °C (158 °F) during operation. The following figure presents the hot surface labels on the robot.



⚠ WARNING

HOT SURFACES

- Avoid unprotected contact with hot surfaces.
- Do not allow flammable or heat-sensitive parts in the immediate vicinity of hot surfaces.
- Verify that the heat dissipation is sufficient by performing a test run under maximum load conditions.

Failure to follow these instructions can result in death, serious injury, or equipment damage.

Hazardous Movements

There can be different sources of hazardous movements:

- No or incorrect calibration of the robotic system
- Wiring or cabling errors
- Errors in the application program
- Component errors
- Error in the measured value and signal transmitter

NOTE: Provide for personal safety by primary equipment monitoring or measures. Do not rely only on the internal monitoring of the components. Adapt the monitoring or other arrangements and measures to the specific conditions of the installation in accordance with a hazard and risk analysis.

⚠ DANGER**UNAVAILABLE OR INADEQUATE PROTECTION DEVICE(S)**

- Prevent entry to the zone of operation with, for example, protective fencing, mesh guards, protective coverings, light barriers or visual protection systems.
- Dimension the protective devices properly and do not remove or modify them.
- Connect safety-related devices only to the dedicated safety-related inputs and outputs of the system.
- Do not make any modifications that can degrade, incapacitate, or in any way invalidate protection devices.
- Protect existing workstations and operating terminals against unauthorized operation.
- Position emergency stop switches so that they are accessible and within reach of the normal position or station of the operator of the equipment.
- Validate the functionality of emergency stop equipment before start-up and during maintenance periods.
- Prevent unintentional start-up by disabling the power stages of the equipment system using the emergency stop circuit or using an appropriate lock-out tag-out sequence.
- Validate the system and installation before the initial start-up.
- Avoid operating high-frequency, remote control, and radio devices close to the system electronics and their feed lines.
- Perform, if necessary, a special electromagnetic compatibility (EMC) verification of the system.

Failure to follow these instructions will result in death or serious injury.

The robotic system may perform unanticipated movements because of incorrect wiring, incorrect settings, incorrect data, or other errors.

⚠ WARNING**UNINTENDED MOVEMENT OR MACHINE OPERATION**

- Carefully install the wiring in accordance with EMC standards.
- Do not operate the robot with undetermined settings and data.
- Perform comprehensive commissioning tests that include verification of configuration settings and data that determine position and movement.

Failure to follow these instructions can result in death, serious injury, or equipment damage.

Noise Protection

The noise level of the mechanics depends on the basic cycle and the payload, as well as on further application-specific accessory parts. Be aware of the fact that noise emissions multiply when several mechanics are in use at the same time. If noise emissions reach a value of more than 70 dBA, wear hearing protection.

⚠ CAUTION
<p>NOISE EMISSIONS OF THE ROBOT MECHANICS</p> <ul style="list-style-type: none"> • Wear hearing protection in accordance with the locally applicable regulations. • Ensure that operators are clearly warned of any potentially excessive noise emissions. <p>Failure to follow these instructions can result in injury or equipment damage.</p>

NOTE: Attach an alert symbol, such as depicted here, where it can easily be seen in the area where the robot is installed.



Emissions

Some small amounts of lubricant emissions are to be expected over time. However, excessive lubricant emissions on or at the gearbox may be an indication of a damaged robot.

NOTICE
<p>INOPERABLE EQUIPMENT INDICATED BY GEARBOX LUBRICANT EMISSIONS</p> <ul style="list-style-type: none"> • Verify the mechanics before, during, and after use. • Shut down the mechanics immediately if lubricant emissions appear on the robot mechanics. <p>Failure to follow these instructions can result in equipment damage.</p>

Hanging Loads

The robot is capable of suspending heavy loads.

⚠ WARNING
<p>FALLING LOADS</p> <ul style="list-style-type: none"> • Do not stand under hanging loads. • Ensure that the robot is properly bolted on the mounting surface. • Ensure that the permissible payload is properly attached on the robot tool flange. <p>Failure to follow these instructions can result in death, serious injury, or equipment damage.</p>

Attachments or Modifications

If different customer end products are transported by the robot mechanics, then the product pickup must be modified accordingly. For this reason, you can mount

different product pickups (gripper mounting) to the flange. In doing so, ensure that the articulation movement is not restricted and/or that no motion errors can result from the modifications. Attachments and rebuilds must not influence the operation of the protective devices in any way and all EMERGENCY STOP buttons must be accessible and operational at all times.

⚠ WARNING

UNINTENDED EQUIPMENT OPERATION

- Do not drill into or modify the articulated arms.
- Do not modify the cable set.
- Do not modify the mounting plate.
- Do not modify the components of movable mechanics.

Failure to follow these instructions can result in death, serious injury, or equipment damage.

Moving the Robot Without Drive Energy

The robot mechanics are not equipped with an enclosure.

NOTE: Take appropriate safety-related measures concerning the specific use before operating the robot.

⚠ WARNING

SAGGING OF THE ROBOT

- Ensure that the robot is in the defined safe state before entering the zone of operation.
- Ensure that the release of the internal holding brakes poses no subsequent risks in the zone of operation.
- Ensure that the emergency stop or the protective stop is enabled.

Failure to follow these instructions can result in death, serious injury, or equipment damage.

If the equipment is with power, perform the following steps:

Step	Action
1	Switch the robot into a torque-free state.
2	Manually hold the robot in position.
3	Release the motor brakes. NOTE: The function for releasing the brakes as well as for torque-free de-energizing the motors is not controlled by the equipment delivered with the product reference, but must be addressed by the application.
4	Manually move the robot. NOTE: An appreciable amount of force could be necessary because the motor and the gearbox may pose resistance to movement.
5	Engage the brakes.

If the equipment is without power, perform the following steps:

Step	Action
1	Disconnect the motor cables from the motors.
2	Apply an external 24 V supply to the appropriate connection points to release the motor brakes if necessary.
3	Release the external brakes engaged by the functional safety system of the robot.
4	Manually move the robot. NOTE: An appreciable amount of force could be necessary because the motor and the gearbox may pose resistance to movement.
5	Remove the external current to close the brakes.
6	Reconnect the motor cables to the motor.

System Overview

What's in This Chapter

System Architecture	24
Product Overview	25
Type Code	28
Type Plate	29

System Architecture

Overview

Apps, Analytics & Services

Edge control

Connected products



NOTE: To help keep your Schneider Electric products secure and protected, refer to the *Cybersecurity Best Practices* and *Cybersecurity Guidelines* provided on the Schneider Electric website. See *Related Documents*.

Product Overview

System Setup

The following figure presents an example of a system setup for one Lexium T robot with MH3 motors. At a minimum, these are the equipments required to achieve performances described in this guide.

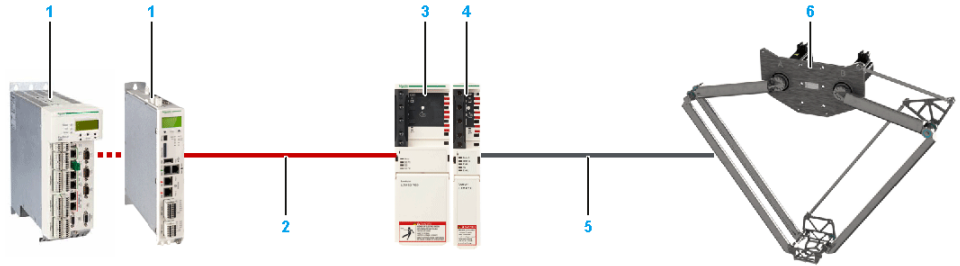

Number	Device name	Quantity	Device type	Comment
1	Controller	1	LMC•00C... LMC•01C	Logic Motion Controller
2	Sercos cable	3	VW3E5001R	Sercos cable; the cable length depends on the distance between controller and cabinet.
3	Power supply	1	LXM62PD84A11000	Lexium 62 Power Supply ⁽³⁾
4	Double drive	1	Double drive ⁽²⁾ : LXM62DD27•21000	Lexium 62 Drive Module
	Single drive	2	Single drive ⁽²⁾ : LXM62DD27•21000	Lexium 62 Drive Module ⁽³⁾
5	Motor cable for connection of drive and motor	2	VW3E1143R•••	PacDrive 3 motor cable; the cable length depends on the distance between cabinet and robot.
	Feedback cable for connection of drive and motor	2	VW3E2094R•••	
6	Lexium T robot	1	(1)	

(1) The device type depends on the robot reference and its characteristics. For further information, refer to *Type Code*, page 28.

(2) The specific variant of the Lexium drive depends on the safety requirements.

(3) Alternatively, use the Lexium LXM52, Stand-Alone Servo Drive. Quantity: 2. Device Type LXM52DD30C.

The following figure presents an example of a system setup for one Lexium T robot with ILM motors. At a minimum, these are the equipments required to achieve performances described in this guide.

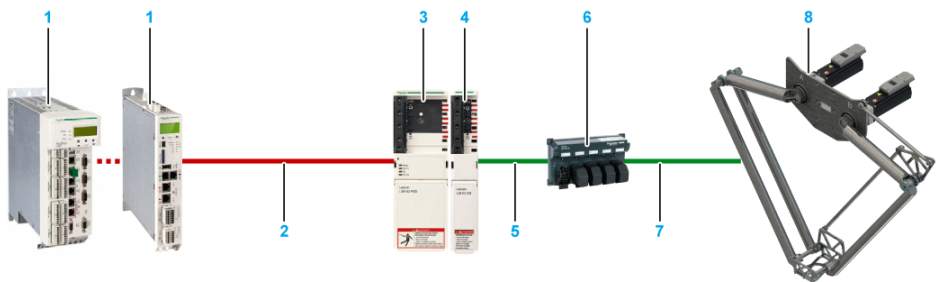

Number	Device name	Quantity	Device type	Comment
1	Controller	1	LMC•00C... LMC•01C	Logic Motion Controller
2	Sercos cable	3	VW3E5001R	Sercos cable; the cable length depends on the distance between controller and cabinet.
3	Power supply	1	LXM62PD84A11000	Lexium 62 Power Supply
4	Connection module	1	ILM62CMD20A000	Lexium 62 Connection Module
5	Cable for connection of connection module and distribution box	2	VW3E1•••R•••	Hybrid cable; the cable length depends on the distance between the cabinet and the robot. Various connector plugs are available.
6	Distribution box	1	ILM62DB4A000	Lexium 62 Distribution Box
7	Cable for connection of distribution box and motor	2	VW3E1•••R•••	Hybrid cable; the cable length depends on the distance between the cabinet and the robot. Various connector plugs are available.
8	Lexium T robot	1	(1)	

(1) The device type depends on the robot reference and its characteristics. For further information, refer to *Type Code*, page 28.

Components Overview

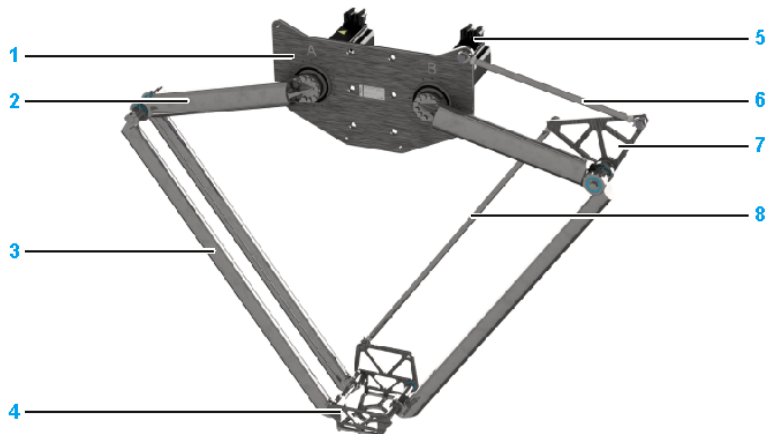

1 Mounting plate

2 Upper arm

3 Lower arm

4 Parallel plate

5 Motor/gearbox

6 Parallel linkage rod short

7 Lever parallel linkage

8 Parallel linkage rod long

Characteristics of the Lexium T Robots

The Lexium T robot provides the following features:

- Stainless steel Delta 2 robot equipped by an automation platform
- Few references covering large performance
- Pre-assembled and ready to connect
- No calibration at customer site
- Compact foot print
- Fast replacement of replacement equipment

Type Code

Overview

Example of a type code for the Lexium T robot:

Character	1	2	3	4	5	6	7	8	9	10	11	12	13	14	15
Example	V	R	K	T	5	M	0	F	N	C	0	0	0	0	0

Description of the type code structure with reference to the example stated above:

Character	Example	Item	Meaning
1...3	VRK	Robot kinematics	–
4...5	T5	Robot/product type	T1 = 2-axis Delta 2 robot 600 mm (23.5 in) T2 = 2-axis Delta 2 robot 800 mm (31.5 in) T3 = 2-axis Delta 2 robot 1000 mm (39 in) T5 = 2-axis Delta 2 robot 1500 mm (59 in) TX = parts for Lexium T robots. For example: replacement equipment.
6...7	M0	Subtype	L0 = ILM motors (T2, T3, T5) M0 = MH3 motors (T1, T2, T3, T5) M1 = MH3 motors heavy duty (T2, T3, T5) WM = without motors (T2, T3, T5) YY = replacement equipment set
8	F	Option	F = fixed, no rotational axis installed C = customized version Y = replacement equipment (replacement equipment for customized editions = C)
9...10	NC	Variant	NC = normal, Compact (T1, T2, T3, T5) YY = replacement equipment
11...12	00	Revision	S00 (T1, T2, T3, T5)
13...15	000	Miscellaneous	000 = without options ... = replacement equipment

If you have questions concerning the type code, contact your local Schneider Electric service representative.

Type Plate

Position of the Type Plate

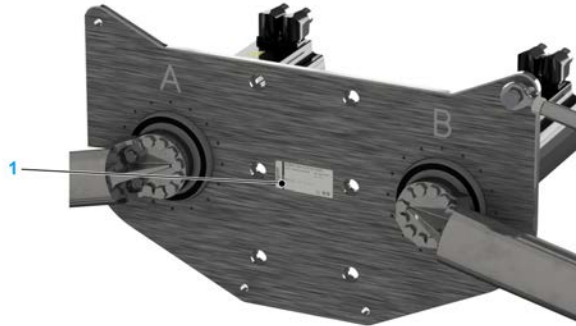

1 Type plate

NOTE: Ensure that the type plate is accessible after installation.

Description of the Type Plate

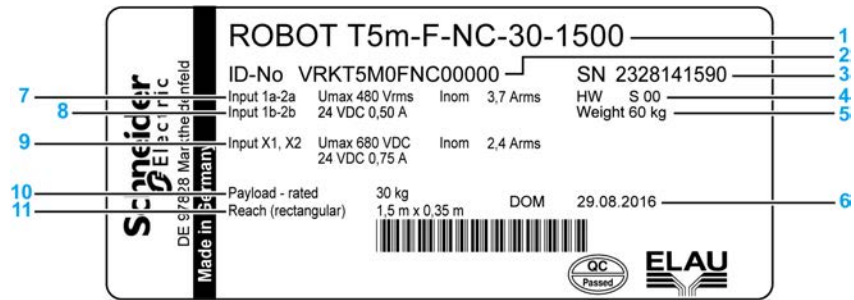

- | | |
|-----------------------|--|
| 1 Device name | 7 Voltage and current of the MH3 motor |
| 2 Type code* | 8 Voltage and current of the MH3 motor brakes |
| 3 Serial number | 9 Voltage and current of the ILM motors and brakes |
| 4 Hardware code | 10 Nominal load |
| 5 Weight of the robot | 11 Radius of the working area |
| 6 Date of manufacture | |

* For detailed information about the meaning of the particular characters, refer to *Type Code*, page 28.

Technical Data

What's in This Chapter

Ambient Conditions 30
 Mechanical and Electrical Data of Lexium T Robots 32
 Dimensional Drawings 36
 Electrical Connections 48
 Performance Data 50
 Design of the Robot Frame 59
 Run-On Motions of the Robot for Risk Analysis 61
 Technical Data of the Motor and the Gearbox 69

Ambient Conditions

Overview

Procedure	Parameter	Unit	Value
Operation ⁽¹⁾	Classes 3K3, 3Z12, 3Z2, 3B2, 3C1, 3M7 (according to IEC/EN 60721-3-3)		
	Ambient temperature	°C (°F)	+5...+40 (+41...+104) ⁽²⁾
	Condensation	–	prohibited
	Formation of ice	–	prohibited
	Relative humidity	%	5...85
Transport	Set of class combinations IE21 (according to IEC/EN 60721-3-2) ⁽³⁾		
	Ambient temperature	°C (°F)	-20...+70 (-4...+158)
	Condensation	–	prohibited
	Precipitation	–	prohibited
	Formation of ice	–	prohibited
	Other liquid	–	prohibited
	Wetness	–	prohibited
	Relative humidity	%	< 75
Long-term storage in transport packaging	Class 1K3 (according to IEC/EN 60721-3-1) ⁽⁴⁾		
	Ambient temperature	°C (°F)	0...+40 °C (+32...+104 °F)
	Condensation	–	prohibited
	Precipitation	–	prohibited
	Formation of ice	–	prohibited
	Other liquid	–	prohibited
	Relative humidity	%	5...95
	Maximum storage period	years	2

(1) Installation altitude without power reduction < 1000 m (3281 ft).

(2) Power reduction for Lexium T Compact versions with ILM motors at ambient temperatures exceeding +25 °C (+77 °F). Power reduction depends on the application. If some severities of parameters deviate from the specified ambient conditions, contact your local Schneider Electric service representative for more information.

(3) The parameters conform to the specified class except for the ambient temperature and the relative humidity which is limited by other components of the system.

(4) The parameters conform to the specified class except for the ambient temperature which is limited by other components of the system.

For further information about storage conditions, refer to *Transport and Storage*, page 71.

Mechanical and Electrical Data of Lexium T Robots

Robot VRKT1...NC

Mechanical and Electrical Data

Category	Parameter	Unit	VRKT1M0FN-C00000
General data	Rated payload	kg (lb)	1.5 (3.3)
	Maximum payload	kg (lb)	15 (33) ⁽²⁾
	Maximum velocity	m/s (ft/s)	5.3 (17.4)
	Maximum acceleration ⁽¹⁾ for 0.1 kg (0.22 lb)	m/s ² (ft/s ²)	49 (160)
	Maximum acceleration ⁽¹⁾ for 1.5 kg (3.3 lb)	m/s ² (ft/s ²)	40 (131)
	Number of axes	–	2
	Position repeatability (ISO 9283)	mm (in)	Position: 0.1 (0.0039)
Electrical data	Mains voltage - 3-phase	Vac	maximum 480 ⁽³⁾
	Control voltage (with brake)	Vdc	+24 (-10...+6%)
	Motor main axes	–	MH30703P02-F2200
	Power consumption for a typical pick-and-place cycle with 1.5 kg (3.3 lb)	kW (hp)	0.7 (0.94)
Mechanical data	Installation type	–	Ceiling installation
	Protection class for moving parts	–	IP64
	Basic protection class	–	IP64
	Housing type	–	Compact
Working area	Height x width	mm (in)	300 x 600 (11.8 x 23.6) 350 x 410 (13.8 x 16.2)
Weight	–	kg (lb)	36.5 (80.2)
Noise level	–	dB(A)	< 70
Material	–	–	Stainless steel, aluminum, FPM, EPDM
<p>(1) For a load mounted centrally underneath the flange and a distance of maximum 100 mm (3.9 in) between flange and mass center of gravity.</p> <p>(2) Loads are subject to restrictions that are application-specific. For more information, contact your local Schneider Electric service representative.</p> <p>(3) For further information, refer to <i>Lexium 52 Hardware Guide</i> or <i>Lexium 62 Hardware Guide</i>. The maximum 480 Vac is the mains voltage of the Lexium 52 Drive or the Lexium 62 Power Supply.</p>			

Robot VRKT2...NC

Mechanical and Electrical Data

Category	Parameter	Unit	VRKT2M0-FNC00000	VRKT2M1-FNC00000	VRKT2L0F-NC00000
General data	Rated payload	kg (lb)	10 (22)		
	Maximum payload	kg (lb)	40 (88) ⁽²⁾	60 (132) ⁽²⁾	40 (88) ⁽²⁾
	Maximum velocity	m/s (ft/s)	5.8 (19)	5.5 (18)	5.8 (19)
	Maximum acceleration ⁽¹⁾ for 1 kg (2.2 lb)	m/s ² (ft/s ²)	60 (197)	37 (121)	60 (197)
	Maximum acceleration ⁽¹⁾ for 10 kg (22 lb)	m/s ² (ft/s ²)	53 (174)	33 (108)	53 (174)
	Number of axes	–	2		
	Position repeatability (ISO 9283)	mm (in)	Position: 0.1 (0.0039)		
Electrical data	Mains voltage - 3-phase	Vac	maximum 480 ⁽³⁾		
	Control voltage (with brake)	Vdc	+24 (-10...+6%)		+24 (-20...+25%)
	Motor main axes	–	MH31002-P02F2200	MH31003-P02F2200	ILM1003-P02F0000
	Power consumption for a typical pick-and-place cycle with 10 kg (22 lb)	kW (hp)	0.85 (1.14)		
Mechanical data	Installation type	–	Ceiling installation		
	Protection class for moving parts	–	IP64		
	Basic protection class	–	IP64		
	Housing type	–	Compact		
Working area	Height x width	mm (in)	350 x 800 (13.8 x 31.5)		
			440 x 500 (17.3 x 19.7)		
Weight	–	kg (lb)	56 (123)	60 (132)	64 (141)
Noise level	–	dB(A)	< 70		
Material	–	–	Stainless steel, aluminum, FPM, EPDM		
<p>(1) For a load mounted centrally underneath the flange and a distance of maximum 100 mm (3.9 in) between flange and mass center of gravity.</p> <p>(2) Loads are subject to restrictions that are application-specific. For more information, contact your local Schneider Electric service representative.</p> <p>(3) For further information, refer to <i>Lexium 52 Hardware Guide</i> or <i>Lexium 62 Hardware Guide</i>. The maximum 480 Vac is the mains voltage of the Lexium 52 Drive or the Lexium 62 Power Supply.</p>					

Robot VRKT3...NC

Mechanical and Electrical Data

Category	Parameter	Unit	VRKT3M0-FNC00000	VRKT3M1-FNC00000	VRKT3L0F-NC00000
General data	Rated payload	kg (lb)	10 (22)		
	Maximum payload	kg (lb)	35 (77) ⁽²⁾	50 (110) ⁽²⁾	35 (77) ⁽²⁾
	Maximum velocity	m/s (ft/s)	6 (19.7)	5.8 (19)	6 (19.7)
	Maximum acceleration ⁽¹⁾ for 1 kg (2.2 lb)	m/s ² (ft/s ²)	62 (203)	55 (180)	62 (203)
	Maximum acceleration ⁽¹⁾ for 10 kg (22 lb)	m/s ² (ft/s ²)	41 (135)	38 (125)	41 (135)
	Number of axes	–	2		
	Position repeatability (ISO 9283)	mm (in)	Position: 0.1 (0.0039)		
Electrical data	Mains voltage - 3-phase	Vac	maximum 480 ⁽³⁾		
	Control voltage (with brake)	Vdc	+24 (-10...+6%)		+24 (-20...+25%)
	Motor main axes	–	MH31002-P02F2200	MH31003-P02F2200	ILM1003-P02F0000
	Power consumption for a typical pick-and-place cycle with 10 kg (22 lb)	kW (hp)	0.85 (1.14)		
Mechanical data	Installation type	–	Ceiling installation		
	Protection class for moving parts	–	IP64		
	Basic protection class	–	IP64		
	Housing type	–	Compact		
Working area	Height x width	mm (in)	380 x 1000 (15 x 39) 480 x 719 (19 x 28.3)		
Weight	–	kg (lb)	60 (132)	65 (143)	65 (143)
Noise level	–	dB(A)	< 70		
Material	–	–	Stainless steel, aluminum, FPM, EPDM		
<p>(1) For a load mounted centrally underneath the flange and a distance of maximum 100 mm (3.9 in) between flange and mass center of gravity.</p> <p>(2) Loads are subject to restrictions that are application-specific. For more information, contact your local Schneider Electric service representative.</p> <p>(3) For further information, refer to <i>Lexium 52 Hardware Guide</i> or <i>Lexium 62 Hardware Guide</i>. The maximum 480 Vac is the mains voltage of the Lexium 52 Drive or the Lexium 62 Power Supply.</p>					

Robot VRKT5...NC

Mechanical and Electrical Data

Category	Parameter	Unit	VRKT5M0-FNC00000	VRKT5M1-FNC00000	VRKT5L0F-NC00000
General data	Rated payload	kg (lb)	10 (22)		
	Maximum payload	kg (lb)	30 (66) ⁽²⁾	45 (99) ⁽²⁾	30 (66) ⁽²⁾
	Maximum velocity	m/s (ft/s)	6.8 (22.3)	7.3 (24)	6.8 (22.3)
	Maximum acceleration ⁽¹⁾ for 1 kg (2.2 lb)	m/s ² (ft/s ²)	58 (190)	64 (210)	58 (190)
	Maximum acceleration ⁽¹⁾ for 10 kg (22 lb)	m/s ² (ft/s ²)	48 (157)	57 (187)	48 (157)
	Number of axes	–	2		
	Position repeatability (ISO 9283)	mm (in)	Position: 0.1 mm (0.0039 in)		
Electrical data	Mains voltage - 3-phase	Vac	maximum 480 ⁽³⁾		
	Control voltage (with brake)	Vdc	+24 (-10...+6%)		+24 (-20...+25%)
	Motor main axes	–	MH31002-P02F2200	MH31003-P02F2200	ILM1003-P02F0000
	Power consumption for a typical pick-and-place cycle with 10 kg (22 lb)	kW (hp)	0.85 (1.14)		
Mechanical data	Installation type	–	Ceiling installation		
	Protection class for moving parts	–	IP64		
	Basic protection class	–	IP64		
	Housing type	–	Compact		
Working area	Height x width	mm (in)	365 x 1500 (14.4 x 59)		
			515 x 1193 (20.3 x 47)		
Weight	–	kg (lb)	60 (132)	65 (143)	65 (143)
Noise level	–	dB(A)	< 70		
Material	–	–	Stainless steel, aluminum, FPM, EPDM		
<p>(1) For a load mounted centrally underneath the flange and a distance of maximum 100 mm (3.9 in) between flange and mass center of gravity.</p> <p>(2) Loads are subject to restrictions that are application-specific. For more information, contact your local Schneider Electric service representative.</p> <p>(3) For further information, refer to <i>Lexium 52 Hardware Guide</i> or <i>Lexium 62 Hardware Guide</i>. The maximum 480 Vac is the mains voltage of the Lexium 52 Drive or the Lexium 62 Power Supply.</p>					

Dimensional Drawings

Dimensional Drawing of the Lexium T Robot

Dimensional Drawing of the Lexium T VRKT1, VRKT2, VRKT3, VRKT5 Robot

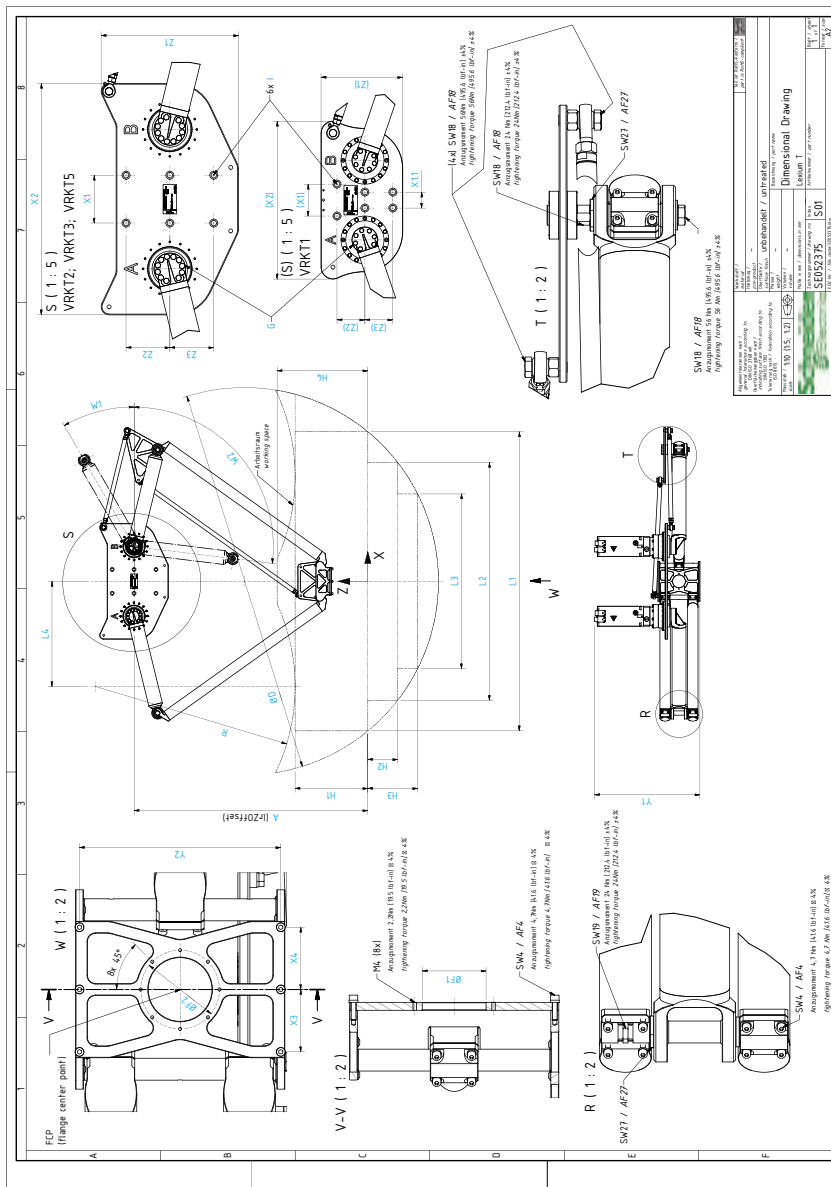

Dimension	Description	Unit	Robot type									
			VRKT1-M0	VRK-T2M0	VRK-T2M1	VRK-T2L0	VRK-T3M0	VRK-T3M1	VRK-T3L0	VRK-T5M0	VRK-T5M1	VRK-T5L0
D	Working area diameter	mm	1100	1290			1500				1945	
		(in)	(43)	(51)			(59)				(77)	
H1	Working area height	mm	300	350			380				365	
		(in)	(11.8)	(13.8)			(15)				(14.4)	
L1	Auxiliary length 1	mm	600	800			1000				1500	
		(in)	(23.6)	(31.5)			(39)				(59)	
H2	Auxiliary height 2	mm	50	90			100				150	
		(in)	(1.97)	(3.54)			(3.9)				(5.9)	

Di- men- sion	Description	Unit	Robot type									
			VRKT1- M0	VRK- T2M0	VRK- T2M1	VRK- T2L0	VRK- T3M0	VRK- T3M1	VRK- T3L0	VRK- T5M0	VRK- T5M1	VRK- T5L0
L2	Auxiliary length 2	mm (in)	412 (16.2)	500 (19.7)			719 (28.3)			1193 (47)		
H3	Auxiliary height 3	mm (in)	-	-			175 (6.9)			250 (9.8)		
L3	Auxiliary length 3	mm (in)	-	-			317 (12.5)			877 (34.5)		
H4	Auxiliary height 4	mm (in)	-	-						455.5 (18)		
L4	Auxiliary length 4	mm (in)	-	-						528 (20.8)		
R	Auxiliary radius	mm (in)	-	-						1000 (39)		
A	Z offset	mm (in)	814 (32)	877 (34.5)			980 (38.6)			1115 (44)		
W1	Angle maximum upper arm height	°	25	30								
W2	Angle minimum upper arm height	°	83	97								
Z2 / Z3	Z distance counterbore mounting plate	mm (in)	70 (2.76)	110 (4.3)								
X1	X distance counterbore mounting plate	mm (in)	80 (3.15)	120 (4.7)								
X1.1	X distance counterbore mounting plate ⁽¹⁾	mm (in)	40 (1.57)	-								
X3 / X4	X distance screw parallel plate	mm (in)	62.5 (2.46)									
Y2	Y distance screw parallel plate	mm (in)	202 (8)									
F1	Flange diameter parallel plate	mm (in)	64 + 0.05 + 0.02 (2.5 + 0.00197 + 0.00079)									
F2	Bolt circle diameter	mm (in)	79 (3.1)									
Z1	Z mounting space of mounting plate	mm (in)	205 (8.07)	345 (13.6)								
X2	X mounting space of mounting plate	mm (in)	396 (15.6)	581 (23)								
Y1	Y mounting space robot	mm (in)	507 (20)	497 (19.6)	529 (21)	598 (23.5)	497 (19.6)	529 (21)	598 (23.-5)	497 (19.6)	529 (21)	598 (23.5)

Di- men- sion	Description		Unit	Robot type							
				VRKT1- M0	VRK- T2M0	VRK- T2M1	VRK- T2L0	VRK- T3M0	VRK- T3M1	VRK- T3L0	VRK- T5M0
I	Cylinder screw size		-	M12							
	Counterbore size		mm (in)	Ø 20 x 8U (Ø 0.79 x 0.31U)							
	Tightening torque		Nm (lbf- in)	56 (496)							
G	screw upper arm to gearbox ⁽²⁾	Wrench size	mm (in)	10 (0.39)	13 (0.51)						
		Tight- ening torque	Nm (lbf- in)	14 (123.9)	22 (194.7)						
		Quanti- ty	-	14	22						
(1) for VRKT1 only											
(2) Medium threadlocked with Loctite 243											

Detail Drawing of the Main Body

Detail Drawing of the Main Body of VRKT1M0-NC

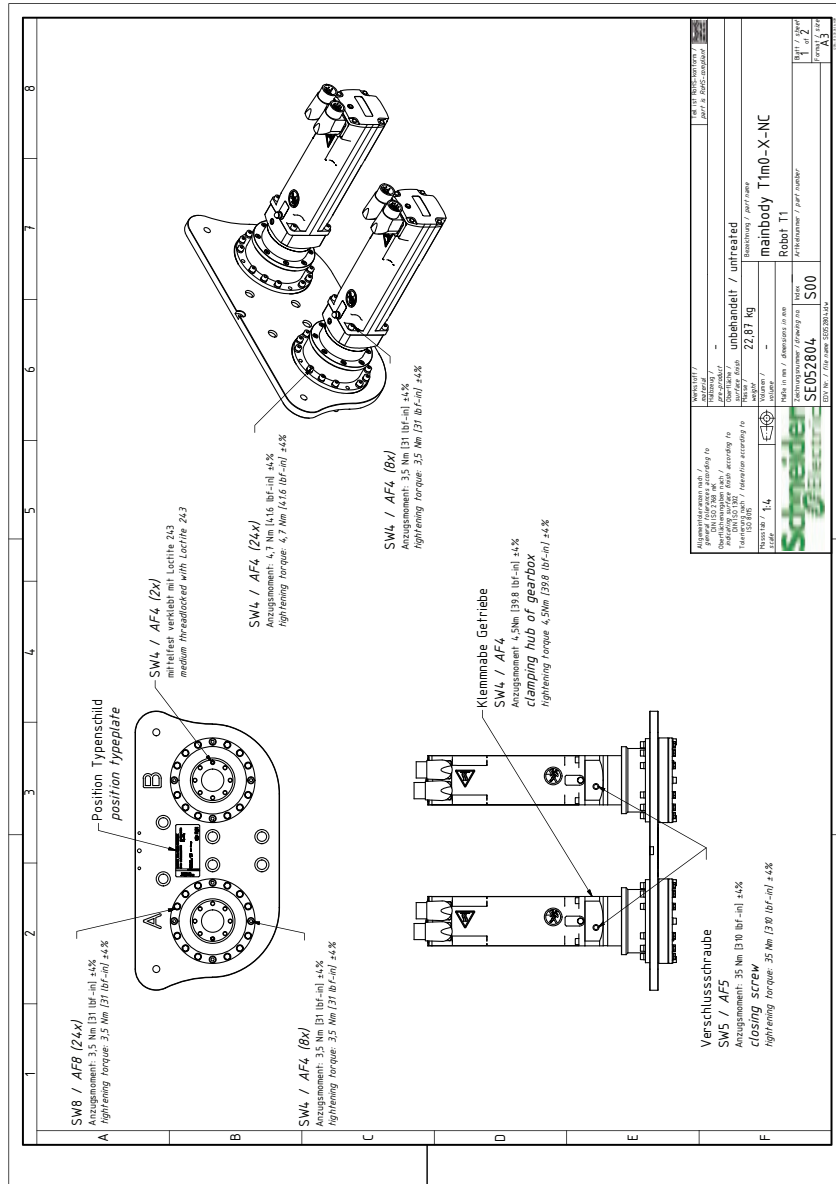

Detail Drawing of the Main Body of VRKT2M0•NC, VRKT3M0•NC, VRKT5M0•NC

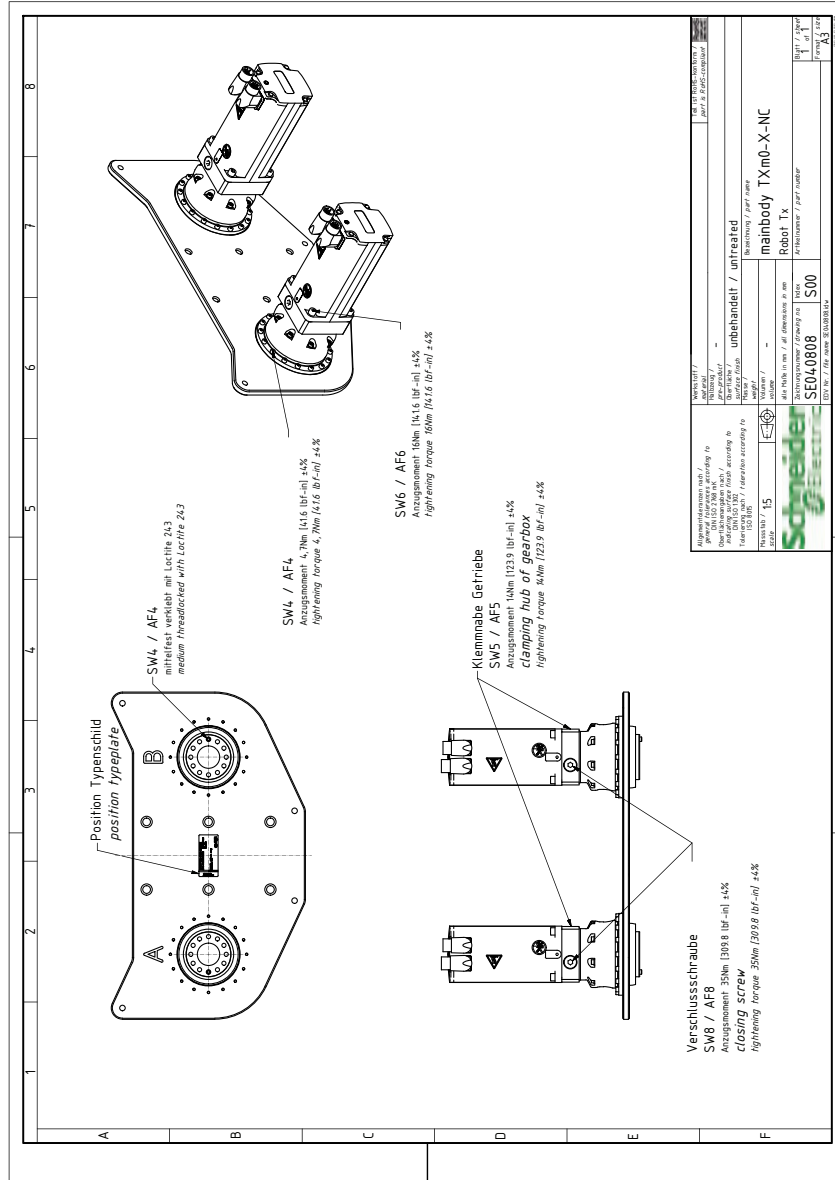

Detail Drawing of the Main Body of VRKT2M1•NC, VRKT3M1•NC, VRKT5M1•NC

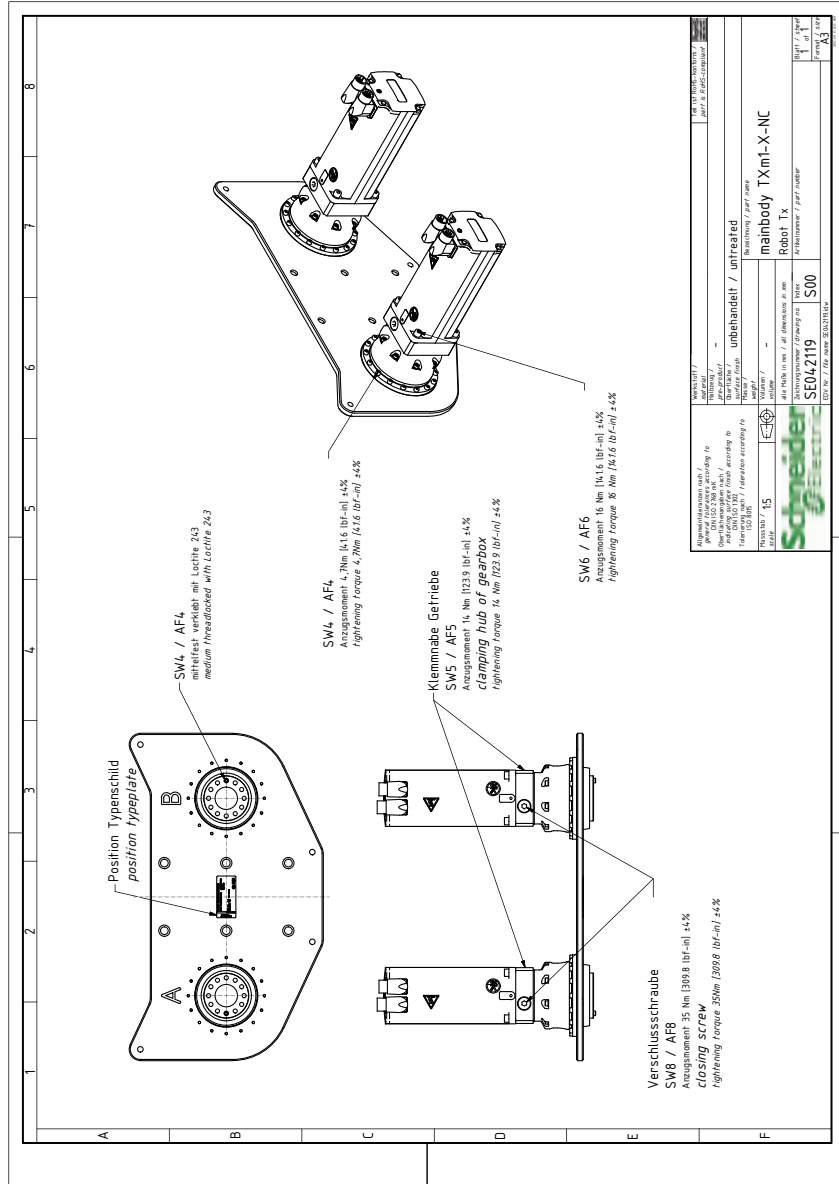

Detail Drawing of the Main Body of VRKT2L•NC, VRKT3L•NC, VRKT5L•NC

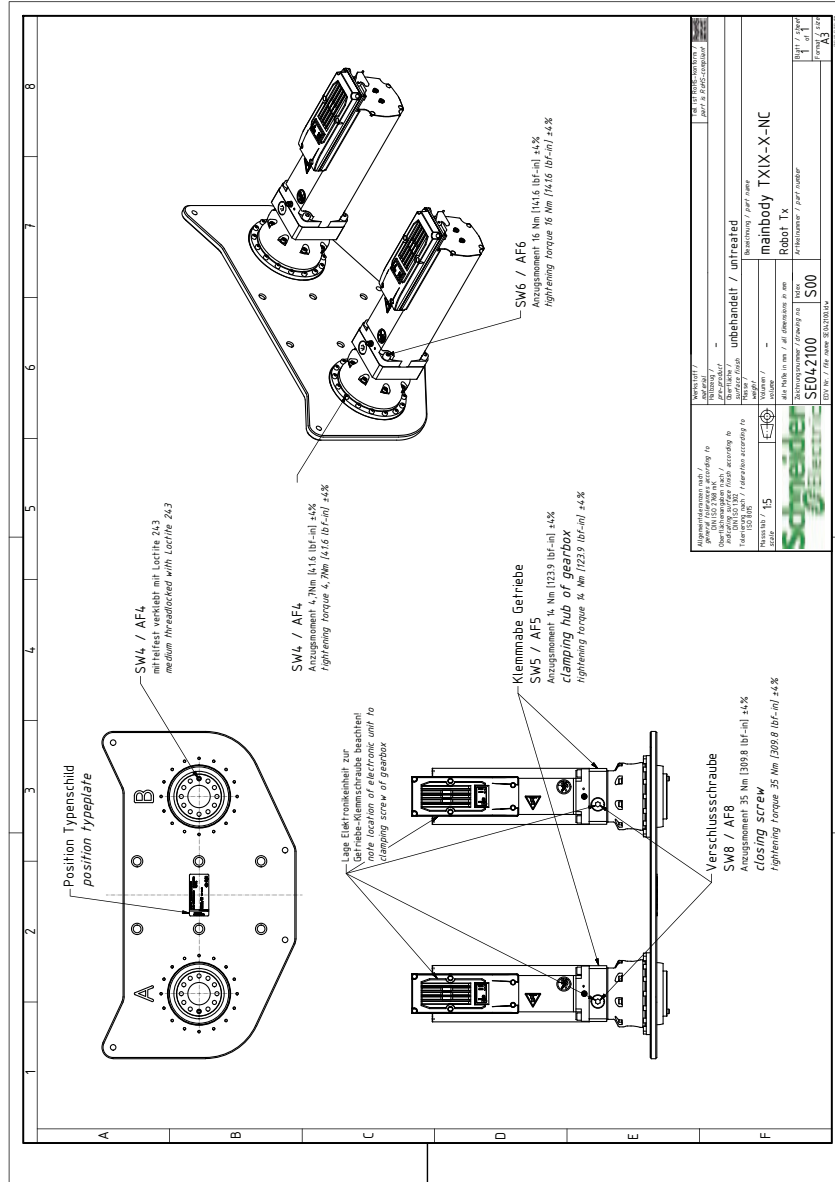

Detail Drawing of the Upper Arm

Detail Drawing of the Upper Arm of VRKT1, VRKT2, VRKT3, VRKT5

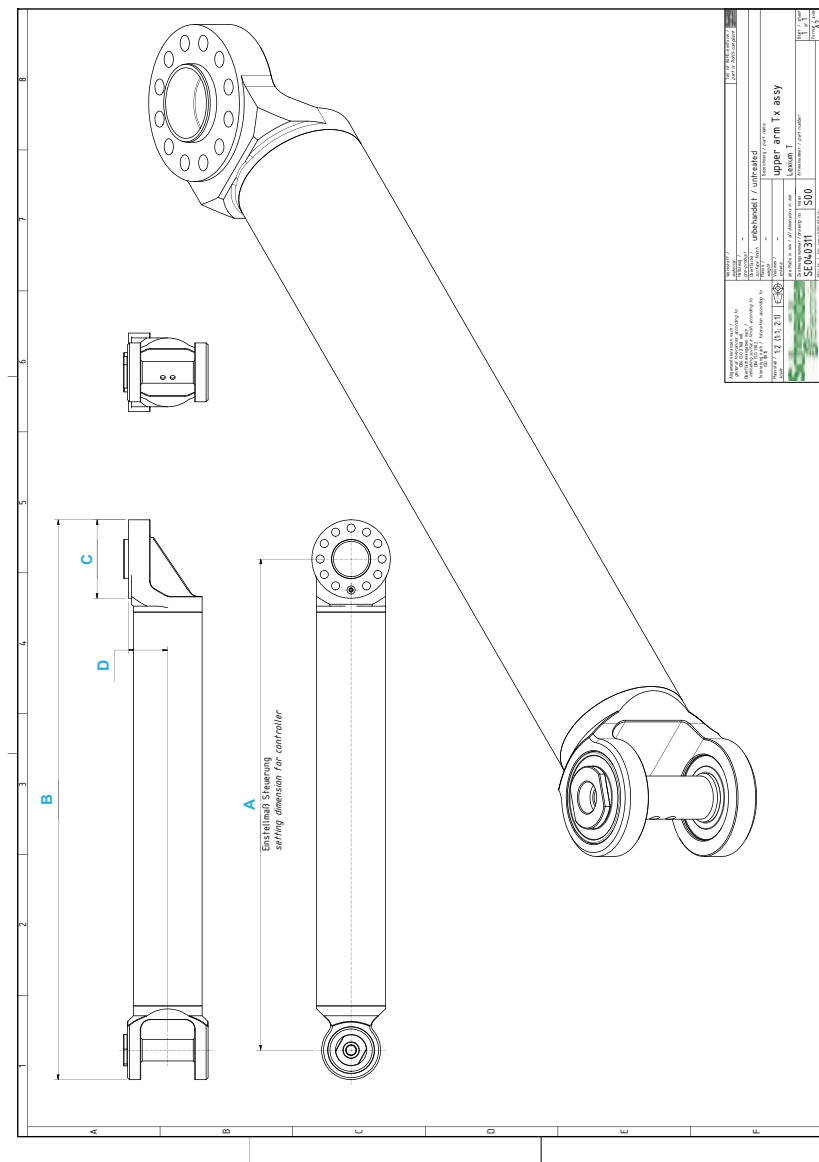

Dimension	Description	Unit	Robot type			
			VRKT1	VRKT2	VRKT3	VRKT5
A	Adjustment value for controller	mm (in)	300 (11.8)	350 (15.7)	400 (15.7)	500 (19.7)
B	Total length	mm (in)	362.5 (14.3)	420 (16.5)	470 (18.5)	570 (22.4)
C	Flange diameter	mm (in)	65 (2.56)	80 (3.15)		
D	Flange center distance	mm (in)	37 (1.46)	40 (1.57)		

Detail Drawing of the Lower Arm

Detail Drawing of the Lower Arm of VRKT1, VRKT2L•NC, VRKT3L•NC, VRKT5L•NC

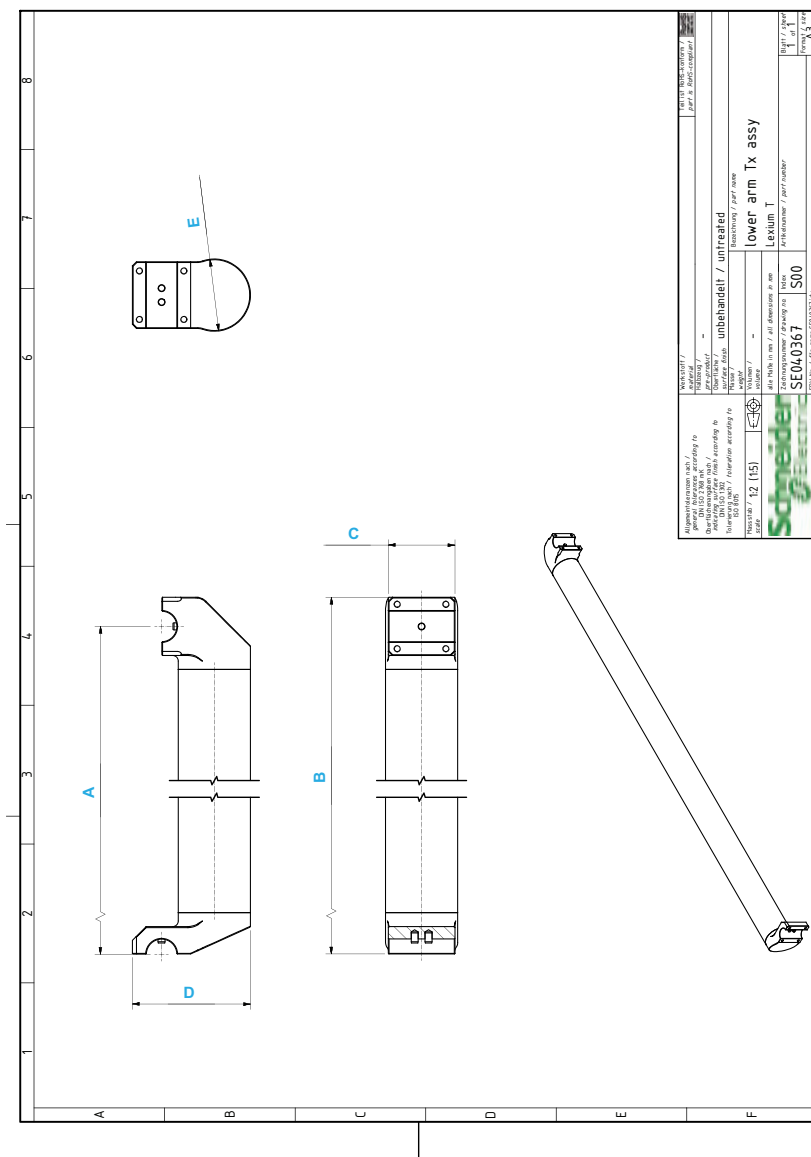

Dimension	Description	Unit	Robot type			
			VRKT1	VRKT2	VRKT3	VRKT5
A	Adjustment value for controller	mm (in)	630 (24.8)	700 (27.6)	800 (31.5)	1000 (39)
B	Total length	mm (in)	650.8 (25.6)	720.8 (28.4)	820.8 (32)	1020.8 (40)
C	Total width	mm (in)	48 (1.9)			
D	Total height	mm (in)	63 (2.48)	85 (3.35)		
E	Tube diameter	mm (in)	34 (1.34)	52 (2.05)		

Detail Drawing of the Parallel Plate

Detail Drawing of the Parallel Plate of VRKT1

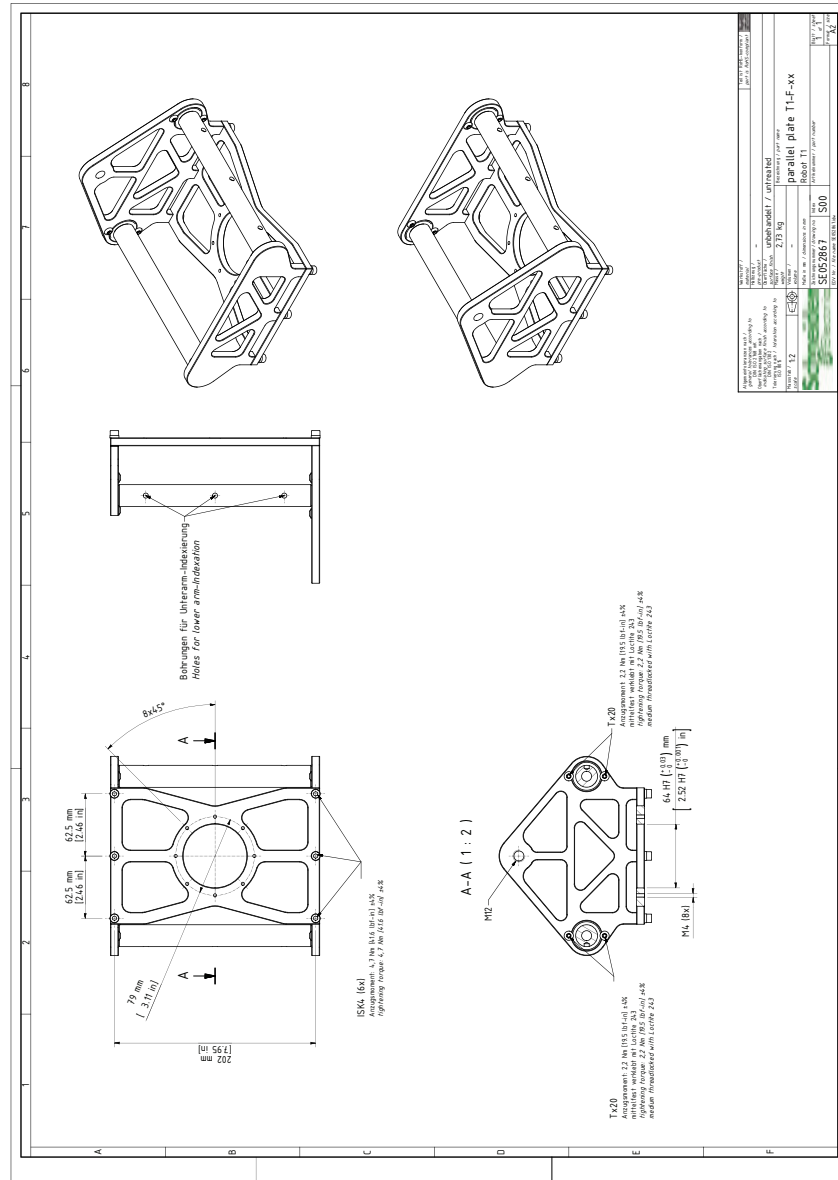

Part No.	VRKT1
Part Name	Parallel Plate 11-E-X
Weight	2.13 kg
Material	Aluminum
Surface Treatment	Anodized
Part No.	500
Part Name	Parallel Plate 11-E-X

Detail Drawing of the Parallel Plate of VRKT2, VRKT3, VRKT5

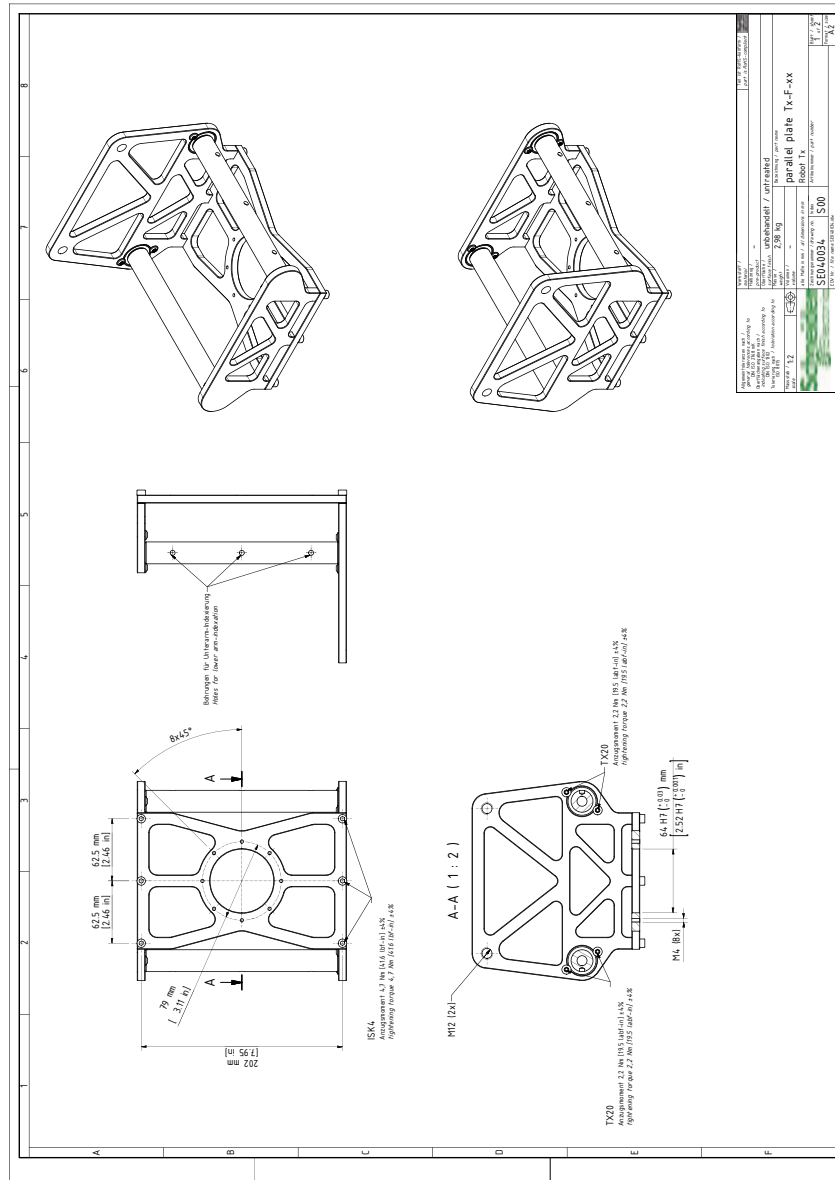

Part Name	parallel plate Tx-F-xx
Material	6061-T6
Surface Treatment	Anodizing
Revision	S100
Drawn By	SEE 04/034
Checked By	
Approved By	

Detail Drawing of the Lever Parallel Linkage

Detail Drawing of the Lever Parallel Linkage of VRKT1, VRKT2, VRKT3, VRKT5

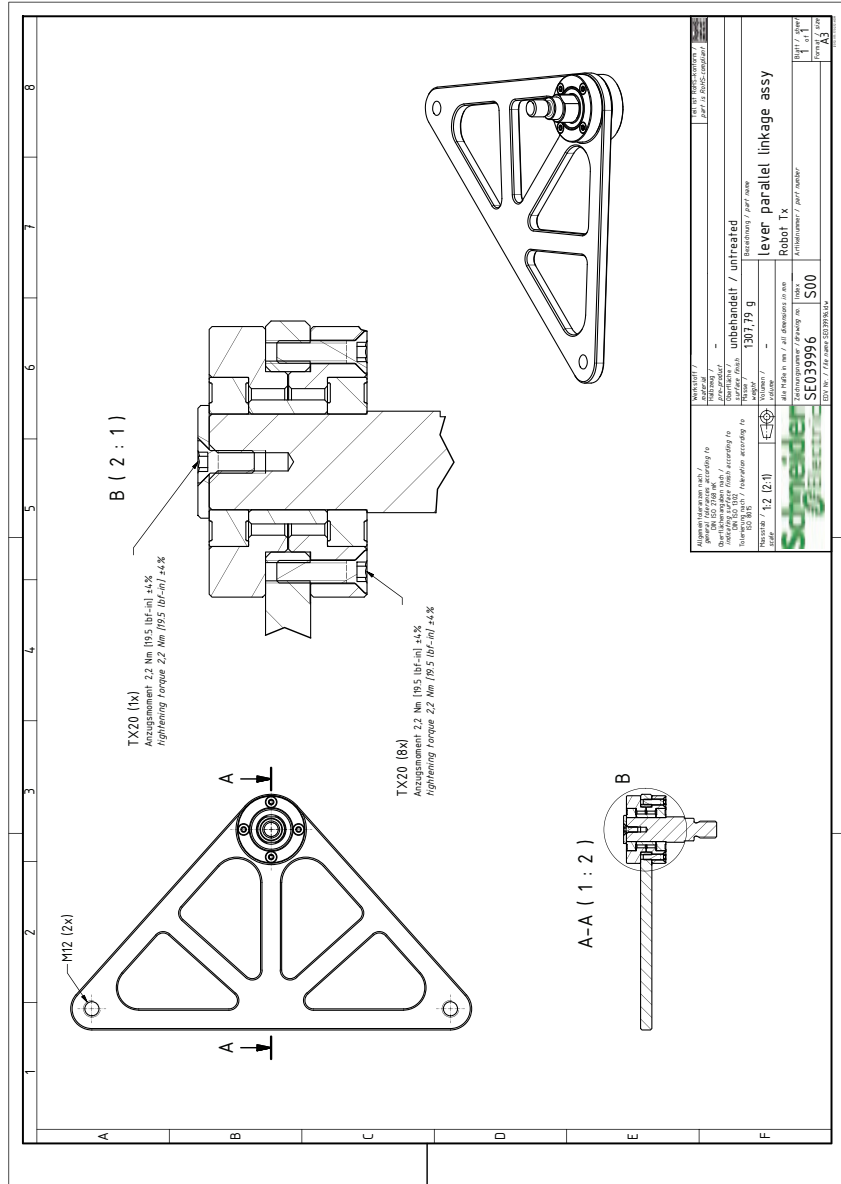

Electrical Connections

Electrical Connections of Lexium T Robots with MH3 Motors (VRKT•M)

Connection power P30 (size 1): Connection power, brake, and temperature sensor

Representation	Pin	Designation	Meaning	Range
	1	W	Performance	3 x 0...480 Vac
	2	PE	Protective ground (earth) cable	–
	3	U	Performance	3 x 0...480 Vac
	4	V	Performance	3 x 0...480 Vac
	A	+	Brake	24 Vdc
	B	-	Brake	0 Vdc
	C	T1	Temperature sensor	–
	D	T2	Temperature sensor	–

Encoder Connection: Encoder SKS/SKM-36

Representation	Pin	Designation	Meaning	Range
	1	REF COS	Reference signal Cosinus	–
	2	RS 485 +	Parameter channel +	–
	3	–	–	–
	4	–	–	–
	5	SIN	Sinusoidal trace	–
	6	REF SIN	Reference signal sine	–
	7	RS 485 -	Parameter channel -	–
	8	COS	Cosine track	–
	9	–	–	–
	10	0 V	Supply Voltage	DC 0 V
	11	–	–	–
	12	U _s	Supply Voltage	DC 7...12 V

Electrical Connections of Lexium T Robots with ILM Motors (VRKT•L)

Connector Lexium 62 ILM Servo Module

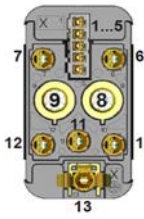
Representation	Pin	Designation	Meaning
	1	IE_sig	Inverter Enable (differential signal)
	2	IE_ref	
	3	Brake	Braking signal
	4	N.C.	Not connected
	5	N.C.	Not connected
	6	24 V	Control voltage 24 V
	7	0 V	Control voltage 0 V
	8.1	Rx+	Sercos port 1 - Input (not assigned for daisy chain wiring)
	8.2	Tx-	Sercos port 1 - Output (not assigned for daisy chain wiring)
	8.3	Rx-	Sercos port 1 - Input (not assigned for daisy chain wiring)
	8.4	Tx+	Sercos port 1 - Output (not assigned for daisy chain wiring)
	9.1	Rx+	Sercos port 2 - Input (not assigned for daisy chain wiring)
	9.2	Tx-	Sercos port 2 - Output (not assigned for daisy chain wiring)
	9.3	Rx-	Sercos port 2 - Input (not assigned for daisy chain wiring)
	9.4	Tx+	Sercos port 2 - Output (not assigned for daisy chain wiring)
	10	DC -	DC bus voltage -
11	Shield	Shielded connector	
12	DC +	DC bus voltage +	
13	PE	Protective ground (earth) cable	

Performance Data

Typical Cycle Time

Robot Path (pick-place-pick):

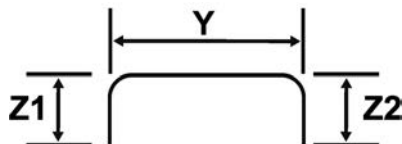

Cycle Times of Robot VRKT1M0

The following measurements are performed at an ambient temperature of 20 °C (68 °F) with a PacDrive 3 and use the SchneiderElectricRobotics library.

Path Z1 x Y x Z2 in mm (in)	Load ⁽²⁾ in kg (lb)	Cycle time ⁽¹⁾ in s	Cycles per minute
25 x 305 x 25 (1 x 12 x 1)	0.1 (0.22)	0.468	128
	1.5 (3.3)	0.512	117
	3.0 (6.6)	0.568	106
	5.0 (11)	0.580	103
	10.0 (22)	0.692	87
	15.0 (33)	0.764	79
70 x 400 x 70 (2.76 x 15.7 x 2.76)	0.1 (0.22)	0.532	113
	1.5 (3.3)	0.548	109
	3.0 (6.6)	0.608	99
	5.0 (11)	0.636	94
	10.0 (22)	0.748	80
	15.0 (33)	0.864	69

(1) Cycle times contain the back and forth motion. A position is considered as reached when the robot remains permanently in a window of +/-0.25 mm (0.0098 in) around the target position.

(2) Loads up to 15 kg (33 lb). Heavier payloads upon request. If required, contact your local Schneider Electric service representative

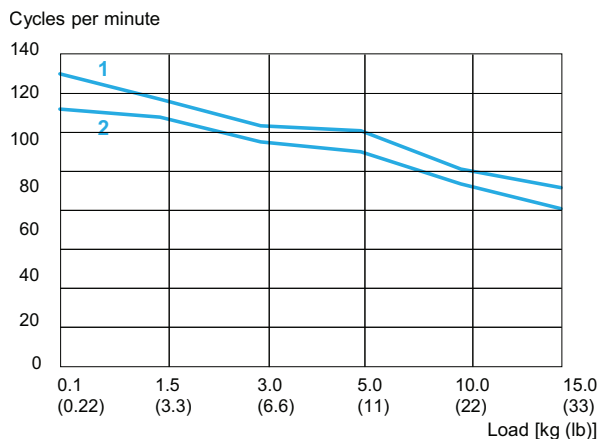

1 25 x 305 x 25 mm (1 x 12 x 1 in)

2 70 x 400 x 70 mm (2.76 x 15.7 x 2.76 in)

Cycle Times of Robot VRKT2M0 / VRKT2L0

The following measurements are performed at an ambient temperature of 20 °C (68 °F) with a PacDrive 3 and use the `SchneiderElectricRobotics` library.

Path Z1 x Y x Z2 in mm (in)	Load ⁽²⁾ in kg (lb)	Cycle time ⁽¹⁾ in s	Cycles per minute
25 x 305 x 25 (1 x 12 x 1)	0.1 (0.22)	0.405	148
	5.0 (11)	0.462	130
	10.0 (22)	0.536	112
	30.0 (66)	0.759	79
	40.0 (88)	0.833	72
70 x 400 x 70 (2.76 x 15.7 x 2.76)	0.1 (0.22)	0.469	128
	5.0 (11)	0.526	114
	10.0 (22)	0.594	101
	30.0 (66)	0.833	72
	40.0 (88)	0.938	64

(1) Cycle times contain the back and forth motion. A position is considered as reached when the robot remains permanently in a window of +/-0.25 mm (0.0098 in) around the target position.

(2) Loads up to 40 kg (88 lb). Heavier payloads upon request. If required, contact your local Schneider Electric service representative

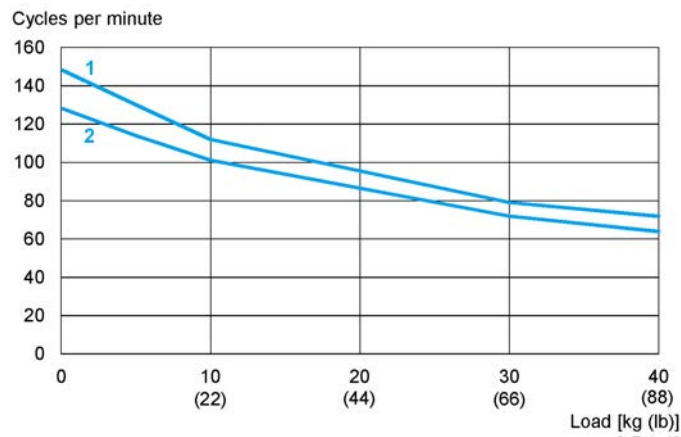

1 25 x 305 x 25 mm (1 x 12 x 1 in)

2 70 x 400 x 70 mm (2.76 x 15.7 x 2.76 in)

Cycle Times of Robot VRKT2M1

The following measurements are performed at an ambient temperature of 20 °C (68 °F) with a PacDrive 3 and use the SchneiderElectricRobotics library.

Path Z1 x Y x Z2 in mm (in)	Load ⁽²⁾ in kg (lb)	Cycle time ⁽¹⁾ in s	Cycles per minute
25 x 305 x 25 (1 x 12 x 1)	0.1 (0.22)	0.438	137
	5.0 (11)	0.500	120
	10.0 (22)	0.583	103
	30.0 (66)	0.779	77
	45.0 (99)	0.896	67
	60.0 (132)	1.034	58
70 x 400 x 70 (2.76 x 15.7 x 2.76)	0.1 (0.22)	0.484	124
	5.0 (11)	0.560	107
	10.0 (22)	0.680	93
	30.0 (66)	0.880	68
	45.0 (99)	1.060	57
	60.0 (132)	1.200	50

(1) Cycle times contain the back and forth motion. A position is considered as reached when the robot remains permanently in a window of +/-0.25 mm (0.0098 in) around the target position.

(2) Loads up to 60 kg (132 lb). Heavier payloads upon request. If required, contact your local Schneider Electric service representative.

Cycles per minute

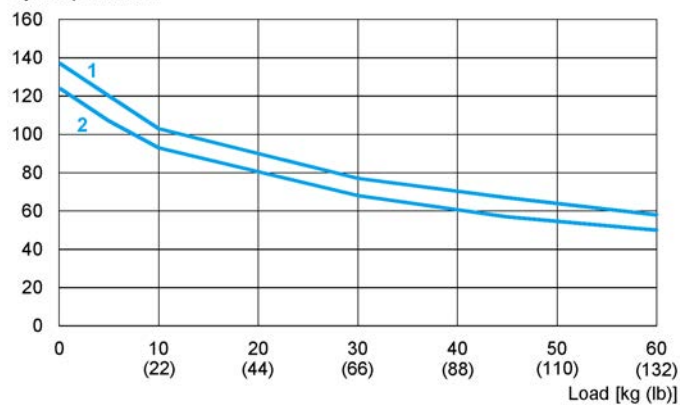

1 25 x 305 x 25 mm (1 x 12 x 1 in)

2 70 x 400 x 70 mm (2.76 x 15.7 x 2.76 in)

Cycle Times of Robot VRKT3M0 / VRKT3L0

The following measurements are performed at an ambient temperature of 20 °C (68 °F) with a PacDrive 3 and use the SchneiderElectricRobotics library.

Path Z1 x Y x Z2 in mm (in)	Load ⁽²⁾ in kg (lb)	Cycle time ⁽¹⁾ in s	Cycles per minute
25 x 305 x 25 (1 x 12 x 1)	0.1 (0.22)	0.419	143
	5.0 (11)	0.478	126
	10.0 (22)	0.558	108
	30.0 (66)	0.778	77
70 x 400 x 70 (2.76 x 15.7 x 2.76)	0.1 (0.22)	0.479	125
	5.0 (11)	0.538	112
	10.0 (22)	0.619	97
	30.0 (66)	0.858	70
90 x 700 x 90 (3.54 x 27.6 x 3.54)	0.1 (0.22)	0.618	97
	5.0 (11)	0.698	86
	10.0 (22)	0.778	77
	30.0 (66)	1.158	52

(1) Cycle times contain the back and forth motion. A position is considered as reached when the robot remains permanently in a window of +/-0.25 mm (0.0098 in) around the target position.

(2) Loads up to 35 kg (66 lb). Heavier payloads upon request. If required, contact your local Schneider Electric service representative.

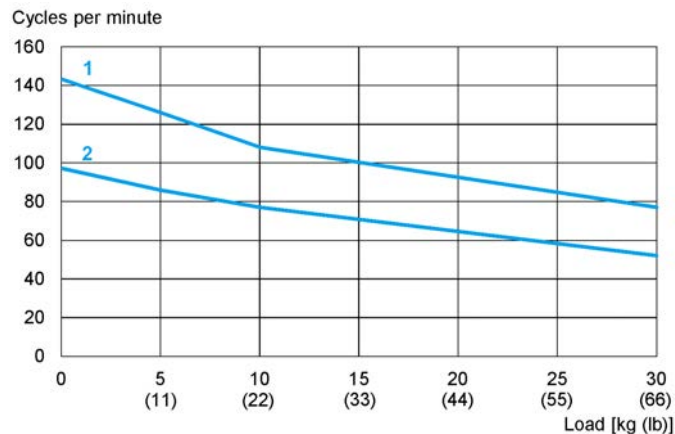

1 25 x 305 x 25 mm (1 x 12 x 1 in)

2 90 x 700 x 90 mm (3.54 x 27.6 x 3.54 in)

Cycle Times of Robot VRKT3M1

The following measurements are performed at an ambient temperature of 20 °C (68 °F) with a PacDrive 3 and use the SchneiderElectricRobotics library.

Path Z1 x Y x Z2 in mm (in)	Load ⁽²⁾ in kg (lb)	Cycle time ⁽¹⁾ in s	Cycles per minute
25 x 305 x 25 (1 x 12 x 1)	0.1 (0.22)	0.460	130
	5.0 (11)	0.519	116
	10.0 (22)	0.619	97
	30.0 (66)	0.818	73
	50.0 (110)	0.998	60
70 x 400 x 70 (2.76 x 15.7 x 2.76)	0.1 (0.22)	0.518	116
	5.0 (11)	0.578	104
	10.0 (22)	0.738	81
	30.0 (66)	0.979	61
	50.0 (110)	1.158	52
90 x 700 x 90 (3.54 x 27.6 x 3.54)	0.1 (0.22)	0.659	91
	5.0 (11)	0.758	79
	10.0 (22)	0.878	68
	30.0 (66)	1.178	51
	50.0 (110)	1.538	39

(1) Cycle times contain the back and forth motion. A position is considered as reached when the robot remains permanently in a window of +/-0.25 mm (0.0098 in) around the target position.

(2) Loads up to 50 kg (110 lb). Heavier payloads upon request. If required, contact your local Schneider Electric service representative.

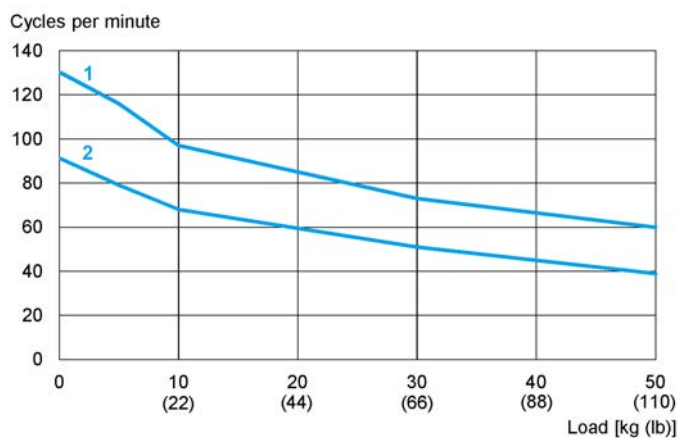

1 25 x 305 x 25 mm (1 x 12 x 1 in)

2 90 x 700 x 90 mm (3.54 x 27.6 x 3.54 in)

Cycle Times of Robot VRKT5M0 / VRKT5L0

The following measurements are performed at an ambient temperature of 20 °C (68 °F) with a PacDrive 3 and use the SchneiderElectricRobotics library.

Path Z1 x Y x Z2 in mm (in)	Load ⁽²⁾ in kg (lb)	Cycle time ⁽¹⁾ in s	Cycles per minute
25 x 305 x 25 (1 x 12 x 1)	0.1 (0.22)	0.448	134
	5.0 (11)	0.541	111
	10.0 (22)	0.675	89
	30.0 (66)	1.077	56
70 x 400 x 70 (2.76 x 15.7 x 2.76)	0.1 (0.22)	0.555	108
	5.0 (11)	0.593	101
	10.0 (22)	0.862	70
	30.0 (66)	1.168	51
90 x 700 x 90 (3.54 x 27.6 x 3.54)	0.1 (0.22)	0.658	91
	5.0 (11)	0.798	75
	10.0 (22)	0.991	61
	30.0 (66)	1.828	33
110 x 1300 x 110 (4.3 x 51 x 4.3)	0.1 (0.22)	0.950	63
	5.0 (11)	1.076	56
	10.0 (22)	1.418	42
	30.0 (66)	2.275	26

(1) Cycle times contain the back and forth motion. A position is considered as reached when the robot remains permanently in a window of +/-0.25 mm (0.0098 in) around the target position.

(2) Loads up to 30 kg (66 lb). Heavier payloads upon request. If required, contact your local Schneider Electric service representative.

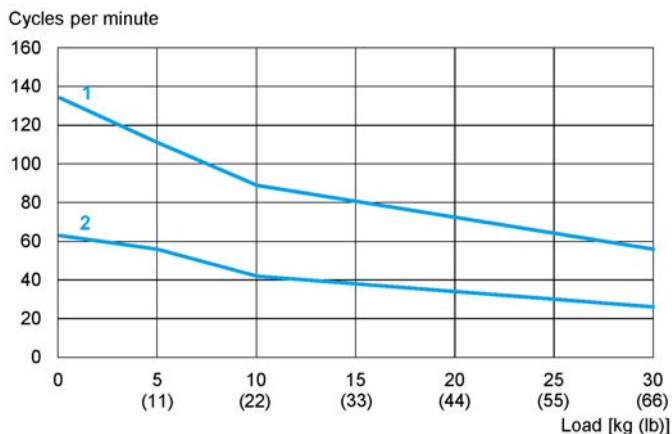

1 25 x 305 x 25 mm (1 x 12 x 1 in)

2 110 x 1300 x 110 mm (4.3 x 51 x 4.3 in)

Cycle Times of Robot VRKT5M1

The following measurements are performed at an ambient temperature of 20 °C (68 °F) with a PacDrive 3 and use the SchneiderElectricRobotics library.

Path Z1 x Y x Z2 in mm (in)	Load ⁽²⁾ in kg (lb)	Cycle time ⁽¹⁾ in s	Cycles per minute
25 x 305 x 25 (1 x 12 x 1)	0.1 (0.22)	0.501	120
	5.0 (11)	0.581	102
	10.0 (22)	0.752	80
	30.0 (66)	0.980	61
	40.0 (88)	1.102	54
70 x 400 x 70 (2.76 x 15.7 x 2.76)	0.1 (0.22)	0.594	101
	5.0 (11)	0.682	88
	10.0 (22)	0.998	60
	30.0 (66)	1.153	52
	40.0 (88)	1.253	48
90 x 700 x 90 (3.54 x 27.6 x 3.54)	0.1 (0.22)	0.751	80
	5.0 (11)	0.893	67
	10.0 (22)	1.092	55
	30.0 (66)	1.575	38
	40.0 (88)	1.875	32
110 x 1300 x 110 (4.3 x 51 x 4.3)	0.1 (0.22)	0.952	63
	5.0 (11)	1.157	52
	10.0 (22)	1.535	39
	30.0 (66)	2.504	24
	40.0 (88)	2.859	21

(1) Cycle times contain the back and forth motion. A position is considered as reached when the robot remains permanently in a window of +/-0.25 mm (0.0098 in) around the target position.

(2) Loads up to 45 kg (88 lb). Heavier payloads upon request. If required, contact your local Schneider Electric service representative

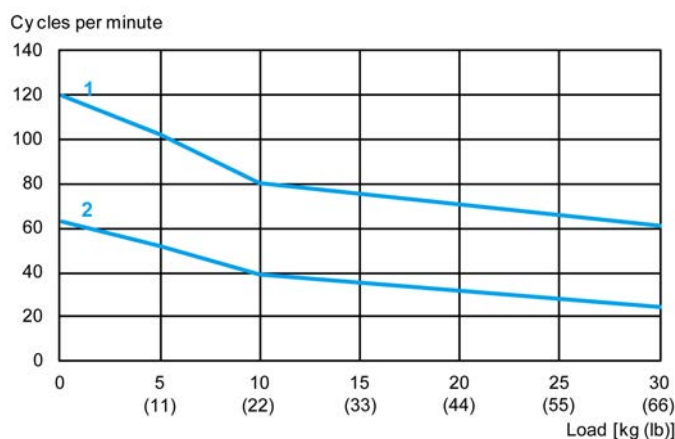

1 25 x 305 x 25 mm (1 x 12 x 1 in)

2 110 x 1300 x 110 mm (4.3 x 51 x 4.3 in)

Load Capacity Diagram

Overview

The load diagram shows the maximum permissible distance of the mass center of gravity from the Flange Center Point (FCP) for a given acceleration relative to the mass. For detailed information, refer to the respective dimensional drawing in *Mechanical and Electrical Data*, page 32.

Maximum Tilting Torque (Vertical Distance from the FCP)

The loading capacity of the Lexium T robots is limited by the maximum tilting torque at the FCP. The following diagrams show the possible vertical distance of the mass center of gravity of the payload relative to the mass and the required maximum acceleration.

For VRKT1:

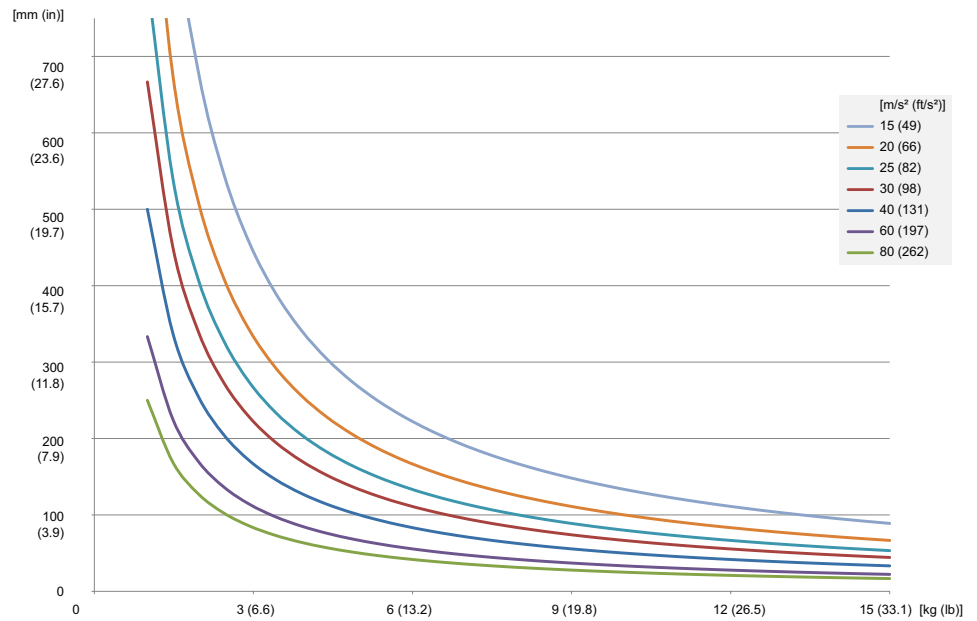

A maximum tilting torque of 20 Nm (177 lbf-in) is to be observed at the FCP:

For VRKT2, VRKT3, VRKT5:

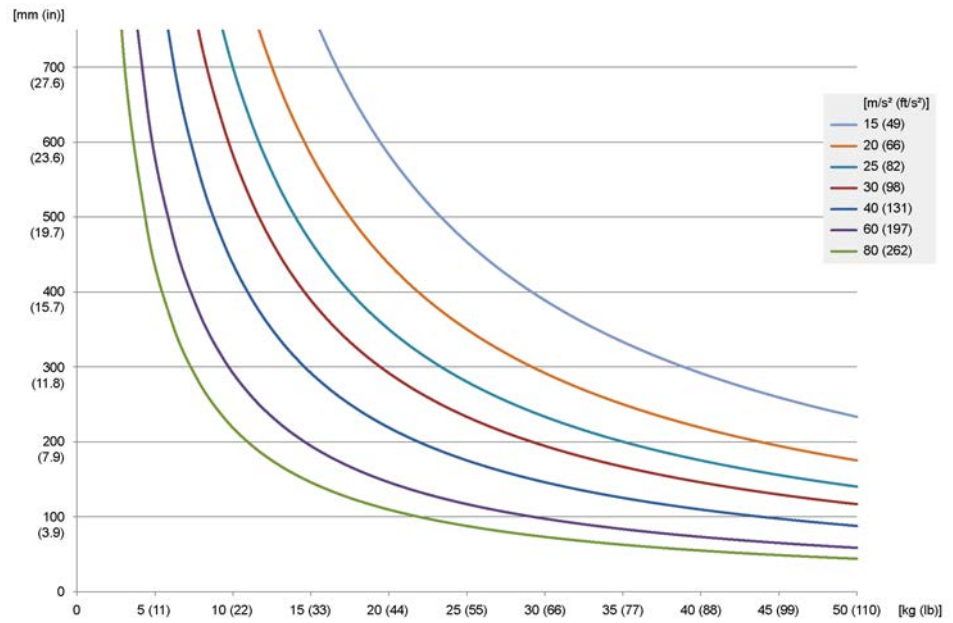

A maximum tilting torque of 175 Nm (1549 lbf-in) is to be observed at the FCP:

Calculate the tilting torque with the following formula:

$$\text{Tilting torque [Nm (lbf-in)]} = \text{payload [kg (lb)]} \times \text{maximum acceleration [m/s}^2 \text{ (ft/s}^2\text{)]} \times \text{distance from the FCP [m (in)]}$$

Design of the Robot Frame

System Requirements

Use the Lexium T robot for ceiling mounting. For special applications with an angularly suspended robot system, contact your local Schneider Electric service representative.

- Delta-2 robots of the Lexium T reach their highest level of performance and accuracy in the center of the working area.
- Position the robot to locate the movements to be executed as closely as possible to the center of the working space.
- When determining the suspension height of the robot, observe the overall height of the gripper (suction cup or other product pickups).
- For the design of the robot frame, account for possible varying gripper heights. Design the robot suspension in a height-adjustable manner.

The precision of the robot in the application is also determined by the frame. Deformations of the frame cause imprecisions on the Tool Center Point (TCP).

General Requirements Regarding the Frame

The frame must not only withstand the constant forces and torques stated below, but also have sufficient stiffness so that the deformations and vibrations which occur do not lead to any major deviations on the TCP. Ensure a sufficient transverse bracing in the frame.

Note the forces and torques to be taken up by the frame during normal operation:

Parameter	Value
Static load	approximately 1.2 kN (270 lbf)
Dynamic load	approximately 10 kN (2248 lbf) in any direction
Dynamic torque	approximately 10000 Nm (88507 lbf-in)

Fasten the robot with six screws of property class 8.8 or greater, or A2-70 or greater.

For further information, refer to the respective dimensional drawing in *Mechanical and Electrical Data*, page 32.

NOTE: The configuration of the robot mechanics, the TCP velocity, as well as the additional payload have an effect on the total energy, which can potentially cause damage.

⚠ WARNING

CRUSHING, SHEARING, CUTTING AND IMPACT INJURY

- The robot must be operated only within an enclosure.
- Open or enter the enclosure for cleaning and maintenance purposes only.
- Design the enclosure to withstand an impact from the robot and to resist ejected parts from escaping the zone of operation.
- Design the enclosure to safely deactivate the robot as soon as a person enters the zone of operation of the robot.
- All barriers, protective doors, contact mats, light barriers, and other protective equipment, must be configured correctly and enabled whenever the robot mechanics are under power.
- Define the clearance distance to the zone of operation of the robot so the operational staff do not have access to, nor can be enclosed in, the robot mechanics zone of operation.
- Design the enclosure to account for the maximum possible travel paths of the robot; that is, the maximum path until the hardware safety system limits as well as the additional run-on paths, in case of a power interruption.

Failure to follow these instructions can result in death, serious injury, or equipment damage.

For further information about travel path and power loss, refer to *Run-on Motions of the Robot for Risk Analysis*, page 61.

Interference Contours in the Enclosure

When designing the enclosure, ensure that the upper and lower arms of the robot will have sufficient freedom of movement. Take into account the required space for the movement of the respective robot type and associated equipment.

For further information, refer to the respective dimensional drawing in *Mechanical and Electrical Data*, page 32.

For detailed information about the interference areas caused by upper and lower arm motions, refer to the 3D-CAD data on the Schneider Electric homepage (www.se.com) or contact your local Schneider Electric service representative.

Run-On Motions of the Robot for Risk Analysis

Overview

What is measured is the time from the application of a stop signal to the standstill of the robot. This measurement is carried out for various different loads and velocities (measurement according to ISO 10218-1).

⚠ WARNING
<p>BREAKDOWN OF THE INTERNAL MOTOR HOLDING BRAKE</p> <ul style="list-style-type: none"> • Do not consider the internal motor holding brake to be a functional safety device. • Take into account a possible breakdown of the internal motor holding brake during your safety analysis. • Take into account that the internal motor holding brake of the robot only withstands a limited number of brake operations. <p>Failure to follow these instructions can result in death, serious injury, or equipment damage.</p>

If there is a power interruption of the control system, the brakes are applied and the robot mechanics leave the planned trajectory.

⚠ WARNING
<p>LEAVING THE PLANNED TRAJECTORY OF THE ROBOT MECHANICS</p> <ul style="list-style-type: none"> • Use the buffering of the 24 V supply (UPS) in order to enable a controlled stop of the mechanics, in accordance with stop category 1, by making use of the stored residual mechanical and electrical energy. • Use a synchronous stop on the path to avoid collisions with obstacles. • Observe the extension of the run-on path while performing your risk analysis. <p>Failure to follow these instructions can result in death, serious injury, or equipment damage.</p>

Stop Function Categories

The following table presents the stop function categories according to IEC 60204-1 that are related to the product:

Stop function category	Definition	Corresponds to
0	Stopping by immediate removal of power to the machine actuators (for example, an uncontrolled stop).	An uncontrolled stop (stopping of machine motion by removing electrical power to the machine actuators).
1	A controlled stop with power available to the machine actuators to achieve the stop and then removal of power when the stop is achieved.	An controlled stop (stopping of machine motion with power to the machine actuators maintained during the stopping process).

Run-On Path Robot VRKT1M0

Run-on path of the robot VRKT1M0 for stop category 0:

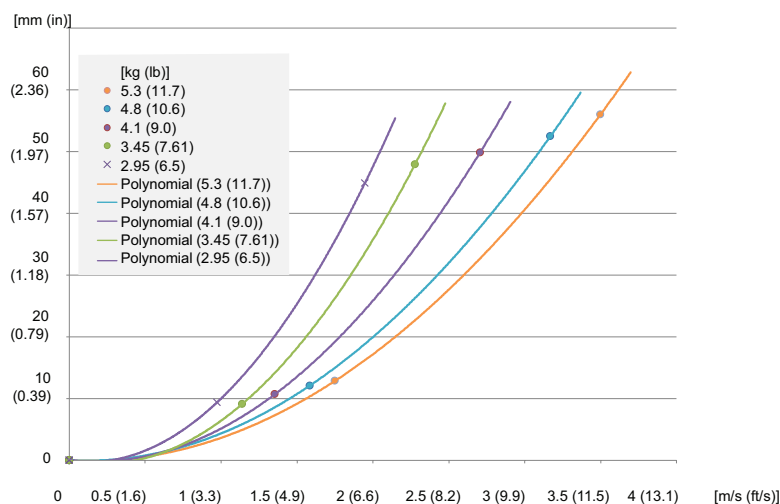

For further information, refer to IEC 60204-1. If necessary, use the holding brake for a stop category 0.

Stopping time of the robot VRKT1M0 for stop category 0:

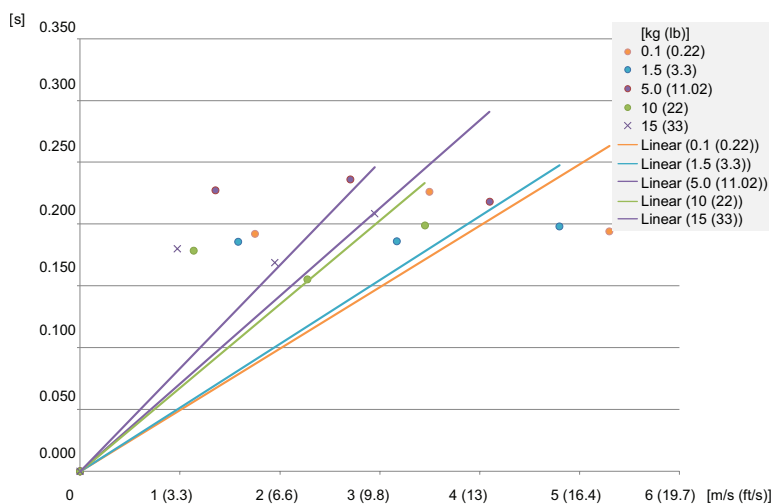

For further information, refer to IEC 60204-1. If necessary, use the holding brake for a stop category 0.

Run-On Path Robot VRKT2M0 and Robot VRKT2L0

Run-on path of the robot VRKT2M0 and the robot VRKT2L0 for stop category 0:

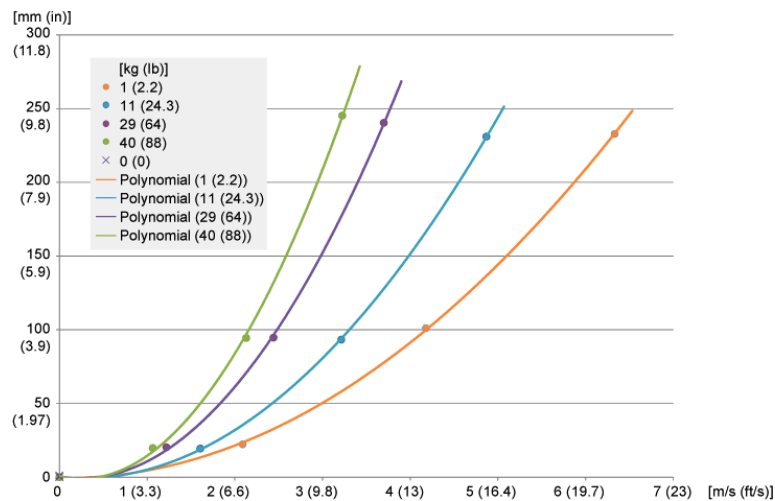

For further information, refer to IEC 60204-1. If necessary, use the holding brake for a stop category 0.

Stopping time of the robot VRKT2M0 and the robot VRKT2L0 for stop category 0:

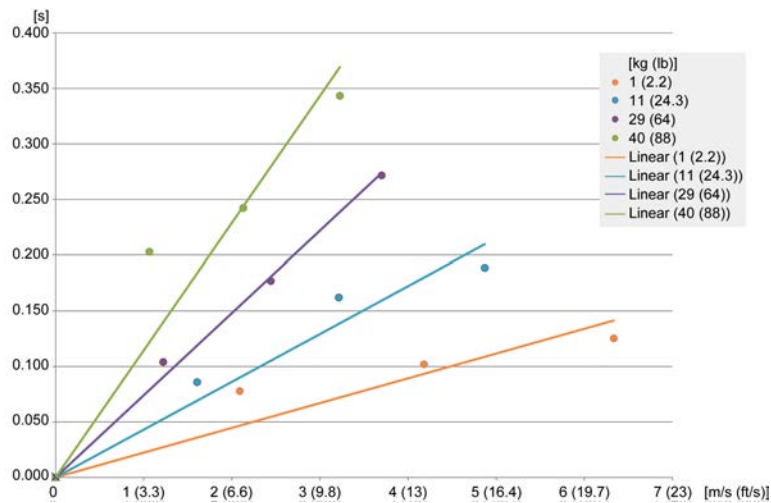

For further information, refer to IEC 60204-1. If necessary, use the holding brake for a stop category 0.

Run-On Path Robot VRKT2M1

Run-on path of the robot VRKT2M1 for stop category 0:

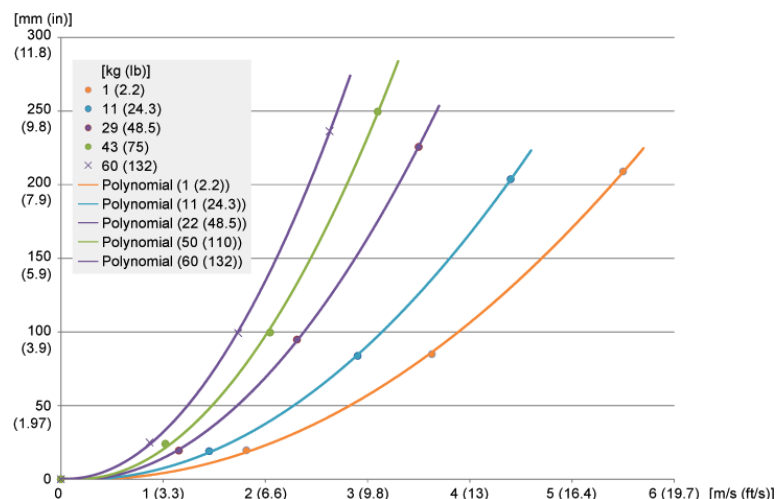

For further information, refer to IEC 60204-1. If necessary, use the holding brake for a stop category 0.

Stopping time of the robot VRKT2M1 for stop category 0:

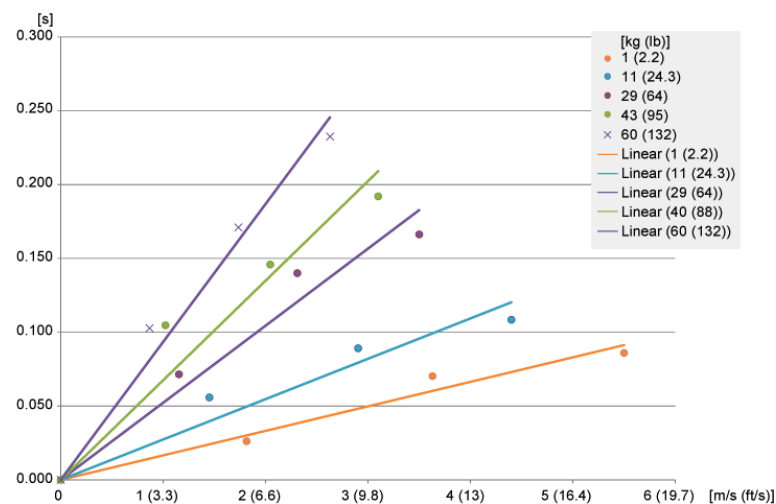

For further information, refer to IEC 60204-1. If necessary, use the holding brake for a stop category 0.

Run-On Path Robot VRKT3M0 and Robot VRKT3L0

Run-on path of the robot VRKT3M0 and the robot VRKT3L0 for stop category 0:

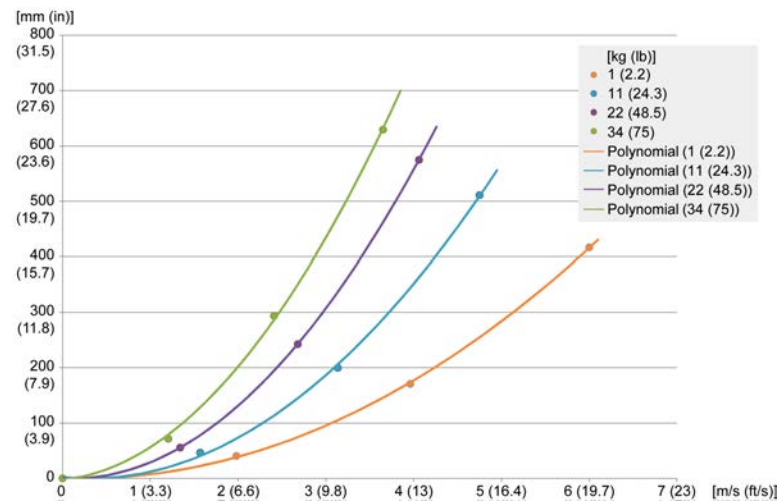

For further information, refer to IEC 60204-1. If necessary, use the holding brake for a stop category 0.

Stopping time of the robot VRKT3M0 and the robot VRKT3L0 for stop category 0:

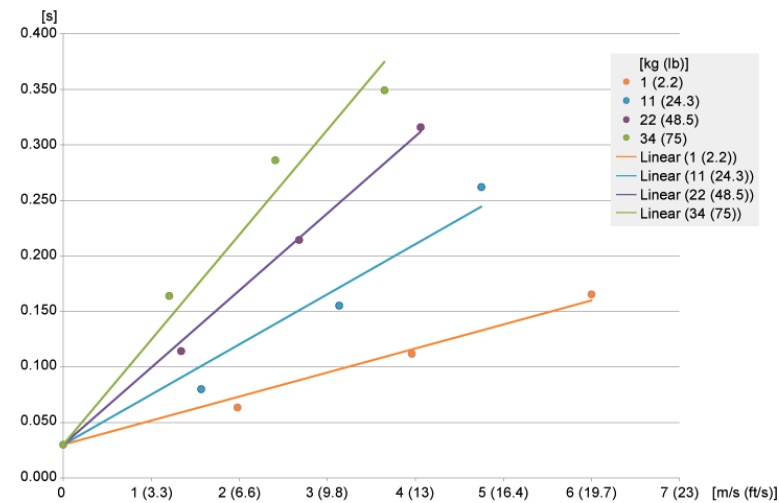

For further information, refer to IEC 60204-1. If necessary, use the holding brake for a stop category 0.

Run-On Path Robot VRKT3M1

Run-on path of the robot VRKT3M1 for stop category 0:

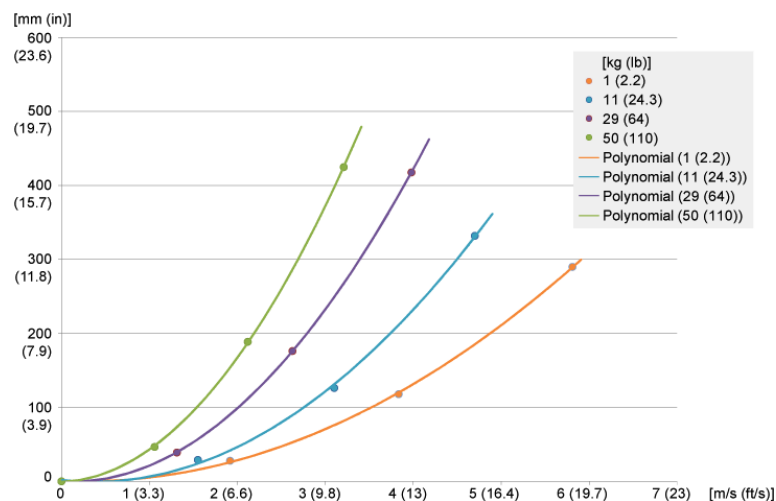

For further information, refer to IEC 60204-1. If necessary, use the holding brake for a stop category 0.

Stopping time of the robot VRKT3M1 for stop category 0:

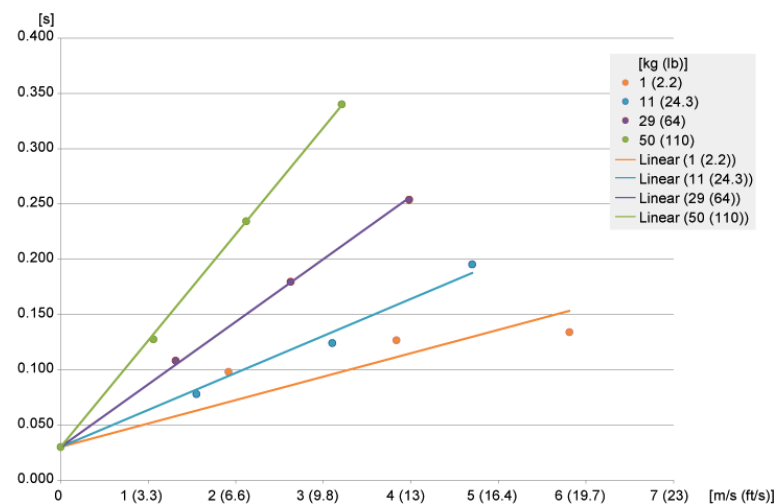

For further information, refer to IEC 60204-1. If necessary, use the holding brake for a stop category 0.

Run-On Path Robot VRKT5M0 and Robot VRKT5L0

Run-on path of the robot VRKT5M0 and the robot VRKT5L0 for stop category 0:

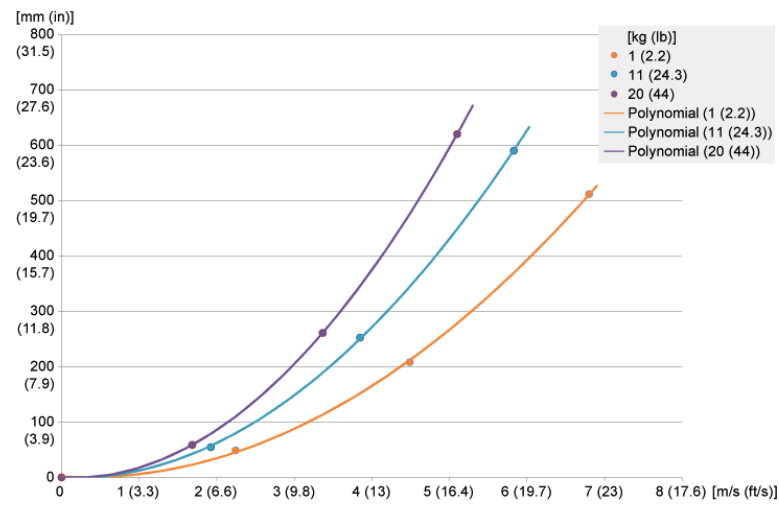

For further information, refer to IEC 60204-1. If necessary, use the holding brake for a stop category 0.

Stopping time of the robot VRKT5M0 and the robot VRKT5L0 for stop category 0:

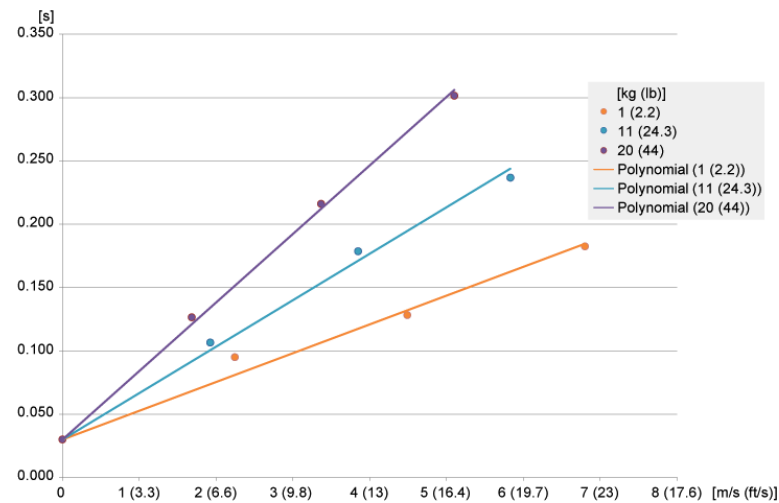

For further information, refer to IEC 60204-1. If necessary, use the holding brake for a stop category 0.

Run-On Path Robot VRKT5M1

Run-on path of the robot VRKT5M1 for stop category 0:

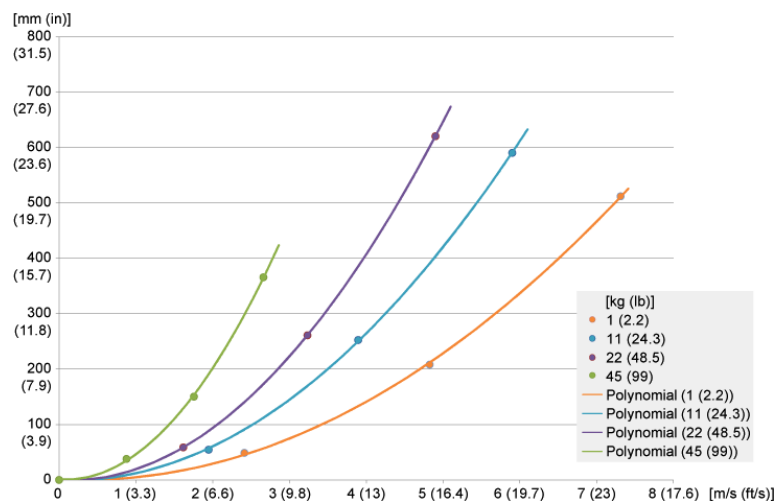

For further information, refer to IEC 60204-1. If necessary, use the holding brake for a stop category 0.

Stopping time of the robot VRKT5M1 for stop category 0:

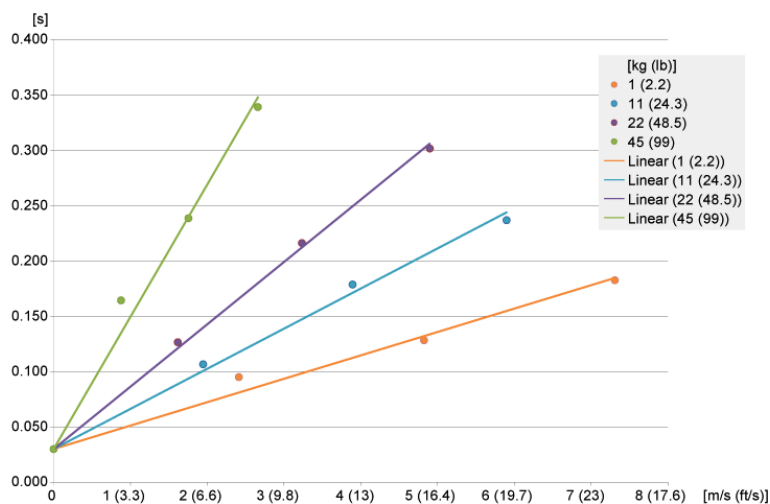

For further information, refer to IEC 60204-1. If necessary, use the holding brake for a stop category 0.

Technical Data of the Motor and the Gearbox

Overview

For further information about the motor, record the motor reference on the type plate and refer to the corresponding motor manual.

For further information about the gearbox, record the gearbox reference on the type plate and refer to the corresponding gearbox manual.

Third-Party Motors

When using a third-party motor, take special care that the maximum permissible drive torque is not exceeded. Otherwise the robot could be rendered inoperable.

⚠ WARNING
UNINTENDED MOVEMENTS
Observe the maximum permissible drive torque of the corresponding motor and gearbox.
Failure to follow these instructions can result in death, serious injury, or equipment damage.

The following table presents the maximum permissible torques at the respective axes.

Parameter	Unit	Robot type	
		VRKT1WM	VRKT2WM VRKT3WM VRKT5WM
Maximum drive torque on the input side of the gearbox M_{max}	Nm (lbf-in)	2.5 (22.1)	9 (80)
Maximum speed on the input side of the gearbox	1/min	8000	6000

NOTE: When using a third-party motor, the protection class of the robot can deviate from that which is stated in *Mechanical and Electrical Data*, page 32. Verify that the protection class corresponds to the environments specified for the robot.

For information about mounting the motor to the gearbox, refer to the corresponding gearbox manual.

The following figure shows the dimensions of the input side of the adapter plate of the gearbox at the main axes.

VRKT1

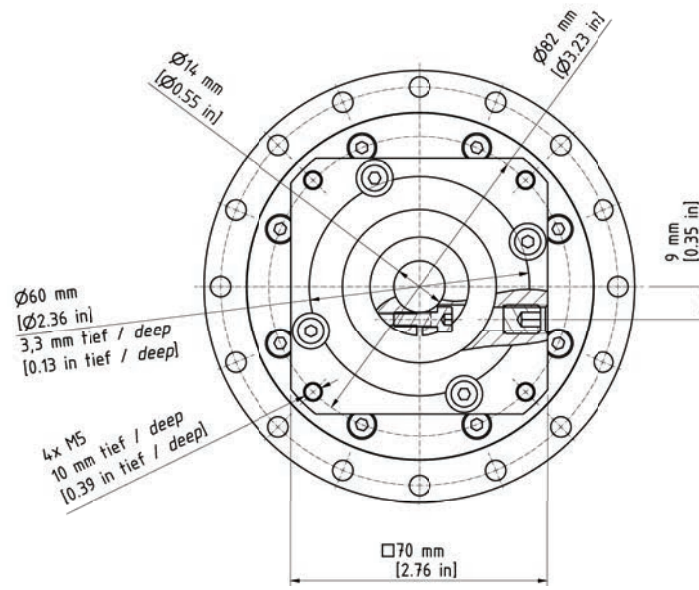

VRKT2, VRKT3, VRKT5

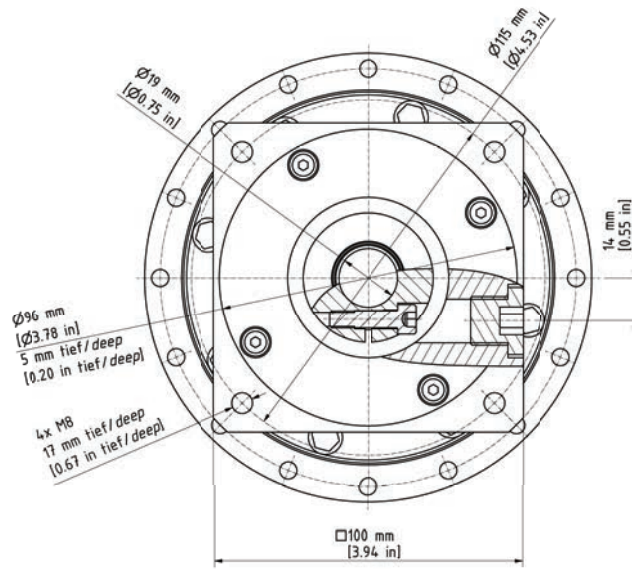

Transport and Commissioning

What's in This Chapter

Transport and Unpacking	71
Mechanical Installation	75
Electrical Installation	79
Initial Start-Up	84
Mounting the Payload	92

Transport and Unpacking

Transport and Storage

Transport Conditions

The Lexium T robot must be handled with care. Shocks and impacts may damage the robot. Damage may lead to reduced running accuracy, reduced service life, or to inoperable equipment.

The robot is preassembled before transport.

NOTE: Before unpacking and installing the robot, make sure that the lifting capacity of the lifting devices (forklift truck and crane) is sufficient to lift the robot. You can find the total weight of your equipment on the container or in the transport documents.

For detailed information about transport conditions, refer to *Ambient Conditions*, page 30.

Storage

The Lexium T robot can be stored inside the packaging or unpacked. In both cases, ensure that it is stored in a sheltered and dry place. Avoid humidity which can have corrosive effects on the robot.

NOTE: When stored, the robot needs to be on a level surface.

For detailed information about transport conditions, refer to *Ambient Conditions*, page 30.

Unpacking

Overview

The following figures show the procedure to unpack and prepare the robot as an example.

Removing the Outer Carton

Step	Action
1	Remove the lashing straps from the outer carton.
2	Open the outer carton (1) on the top side and open the corrosion protection bag (not shown in graphic).
3	Lift up and remove the outer carton (1).
4	Remove the six carton corners (2) and the supporting carton (3).

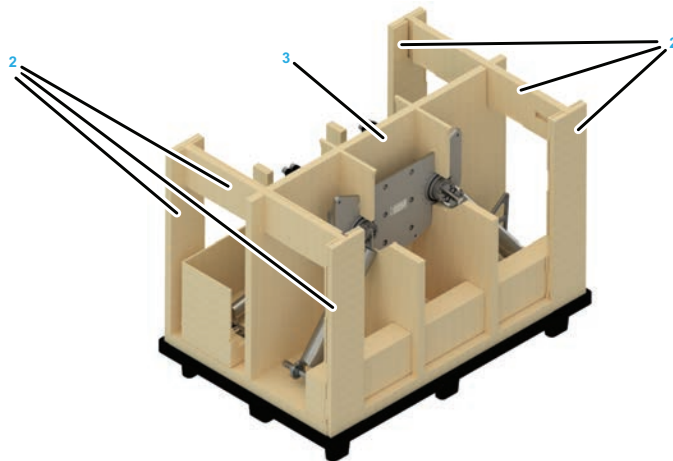
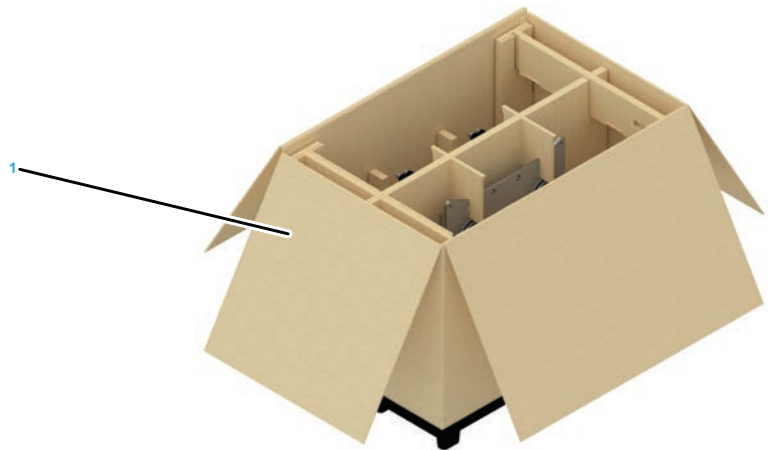

Presentation of the Robot Packaging

The following figure shows the packaging of robot:

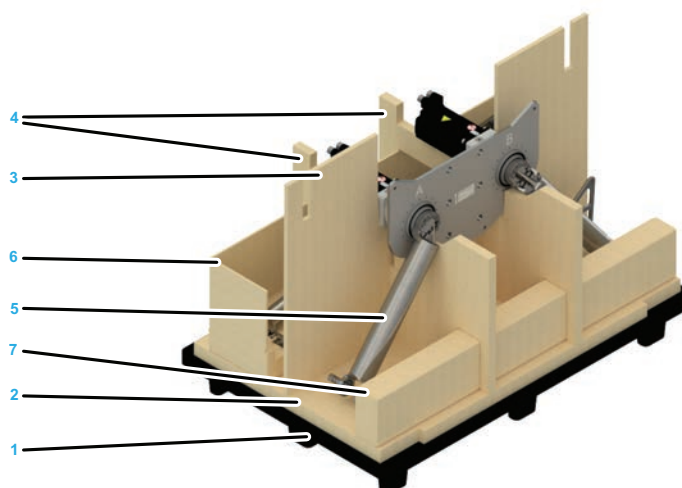

1 Plastic pallet (120 x 80 cm (47 in x 31.5 in))

2 Base carton

3 Cross piece carton single

4 Cross piece carton double

5 Upper arms in transportation position

6 Insert carton robot arm

7 Accessories carton box

Preparing the Robot for Installation

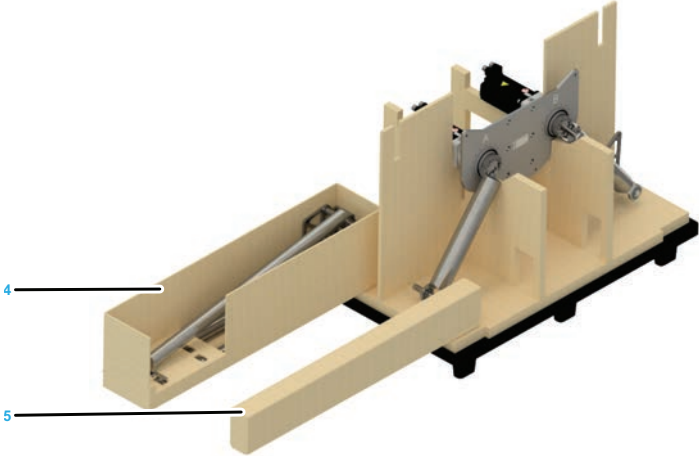
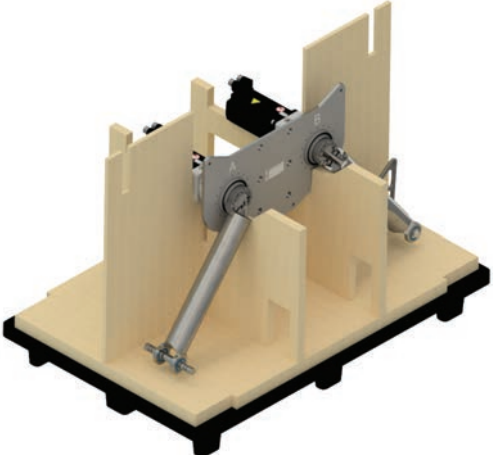
Step	Action
1	<p>Slide out the insert carton robot arm (4) and the accessories carton box (5) to the left or right and verify it for transport damage.</p> 
2	<p>Verify the robot for transport damage.</p>
3	<p>Open the accessories box and verify all included parts for transport damage and completeness.</p> <p>It must contain:</p> <ul style="list-style-type: none"> • 1x parallel linkage rod long • 1x parallel linkage rod short • 3x half shell for lower arm fixing • 12x screw for half shell • 12x lock washer for half shell • 1x instruction sheet for Lexium T (NAT24232) 

NOTE: In case of transport damage, contact your Schneider Electric representative.

For information about the disposal of the packaging, refer to *Disposal*, page 128.

Mechanical Installation

Information About Installation

Overview

Proceed with care during the following steps in order to help to prevent the following points:

- Injuries and material damage
- Incorrect installation and programming of components
- Incorrect operation of components
- Use of non-authorized cables or modified components

For further Information, refer to *Hazard Information*, page 12.

Mounting the Robot

Overview

There are two ways of proceeding for handling and mounting of the robot. Study both ways of proceeding and determine which one is appropriate for your environment.

Installing by Forklift Truck

⚠ WARNING

FALLING LOADS

- Drive slowly and carefully with the forklift truck.
- Do not carry out any sudden steering movements.
- Exercise care when initiating height adjustments of the forklift truck loading platform.

Failure to follow these instructions can result in death, serious injury, or equipment damage.

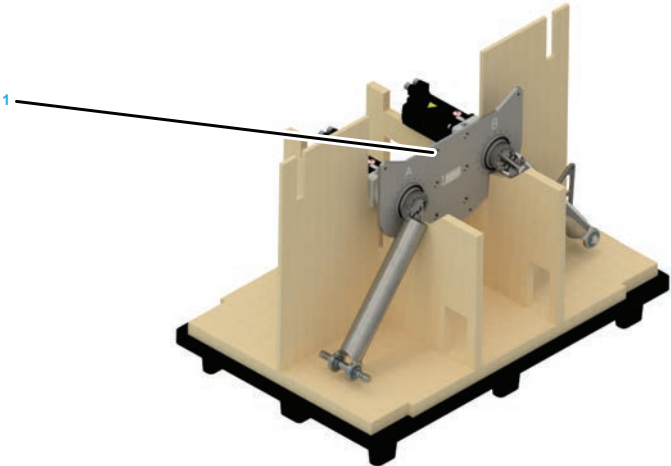
Step	Action
1	<p>Using a forklift truck, lift the robot and the pallet into the enclosure.</p> 
2	<p>Fasten the robot to the frame using the six provided counterbores (1).</p> <p>Size of the counterbore: M12</p> <p>Tightening torque: 56 Nm (496 lbf-in)</p> <p>Property class of the screws: 8.8 or greater, or A2-70 or greater</p> 
3	<p>Remove the cross piece cartons, the base carton and the plastic pallet from the robot.</p>

For information about the disposal of the packaging, refer to *Disposal*, page 128.

Installing by Crane

NOTE: The motors cannot carry the weight of the robot.

⚠ WARNING

FALLING HEAVY LOAD

- Attach lifting lugs to the mounting plate only.
- Do not attach lifting lugs to the upper arms or the motors.

Failure to follow these instructions can result in death, serious injury, or equipment damage.

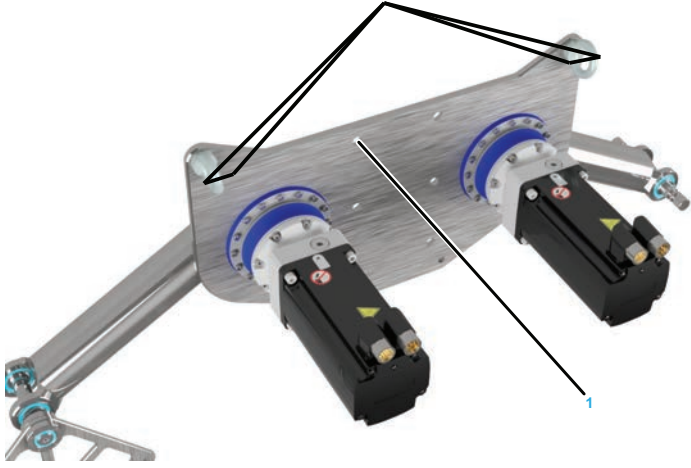
Step	Action
1	<p>Pull two lifting lugs to the crane eyes at the mounting plate.</p> 
2	<p>Use the crane to carefully lift the robot into the enclosure.</p>
3	<p>Fasten the robot to the frame using the six provided counterbores (1).</p> <p>Size of the counterbore: M12</p> <p>Tightening torque: 56 Nm (496 lbf-in)</p> <p>Property class of the screws: 8.8 or greater, or A2-70 or greater</p>

Electrical Installation

Cabling the VRKT•M•NC

Procedure Overview

Perform the following procedures to cable the robot:

- Cabling the robot, page 79
- Grounding the robot, page 80
- Reducing risks around the robot, page 81

Cabling the Robot

Step	Action
1	Feed the two encoder cables to the motors (1). 
2	Feed the two power cables to the motors (1). NOTE: For equipment that you are supplying that are not described in the present document, consult the documentation for those products.
3	Attach the encoder and the motor supply cables as described in the <i>MH3 Servo motor Motor Manual</i> .
4	Couple the DC buses of the servo amplifiers so that braking motors can feed back their power to the accelerating motors in the case of an on-path stop of the robot. NOTE: Due to the coupling of the DC buses, the existing energy suffices in many cases for an on-path stop of the robot. In case of a breakdown of the 24 Vdc supply, this measure of the feedback does not take effect.
5	Verify the correct routing and fastening of the cables.

⚡ ⚠ DANGER

ELECTRIC SHOCK DUE TO LOOSE WIRING OR CABLING

Tighten wiring or cabling connections in conformance with the torque specifications.

Failure to follow these instructions will result in death or serious injury.

Incorrect pairing of the motor and encoder cables can result in incorrect operation of the robot.

⚠ WARNING

UNINTENDED EQUIPMENT OPERATION



Label the motor and associated encoder cables according to their pairing.

Failure to follow these instructions can result in death, serious injury, or equipment damage.

For further information, refer to *Lexium 62 Hardware Guide* or *Lexium 52 Hardware Guide*.

Grounding the Robot

NOTE: When grounding the robot, use cables that comply with the applicable local standards, for example, cables that conform to NEC 70 / NFPA 79 in the USA.

Step	Action
1	<p>Fasten the ground cables to the ground connections (1) of robot motors. The ground connections are marked with the following symbol:</p> <div style="text-align: center;">  </div> <p>Tightening torque: 2.9 Nm (25.7 lbf-in)</p> <div style="text-align: center;">  </div> <p>NOTE:</p> <ul style="list-style-type: none"> • The graphic is an example for the position of the ground connection at a main axis motor. • The external protective ground connection wiring is determined by a number of variables. <div style="background-color: black; color: white; padding: 5px; text-align: center; font-weight: bold; font-size: 1.2em;">⚡ ⚠ DANGER</div> <div style="border: 1px solid black; padding: 5px;"> <p>ELECTRIC SHOCK DUE TO IMPROPER GROUNDING</p> <ul style="list-style-type: none"> • Ground robot components in accordance with local, regional and/or national standards and regulations at a single, central point. • Verify that the motors are connected to the ground plane of the application. <p>Failure to follow these instructions will result in death or serious injury.</p> </div> <p>Multipoint grounding is permissible if connections are made to an equipotential ground plane dimensioned to help avoid cable shield damage in the event of power system short-circuit currents.</p>
2	Verify the correct routing and fastening of the cables.

Reducing Risks Around the Robot

Step	Action
1	Install external safety-related devices in accordance to local regulations and standards.
2	<p>When designing the safety-related devices, assume that the robot cannot be stopped by internal logic and must be stopped by the external safety-related devices.</p> <p>NOTE: More information about the circuitry of emergency stop and additional protection elements is contained in the document <i>Lexium 52 Hardware Guide</i>, <i>Lexium 62 Hardware Guide</i>, or <i>Lexium 62 ILM Hardware Guide</i>.</p>

Cabling the VRKT•L•NC

Procedure Overview

Perform the following procedures to cable the robot:

- Cabling the Robot, page 82
- Grounding the Robot, page 82
- Reducing Risks Around the Robot, page 83

Cabling the Robot

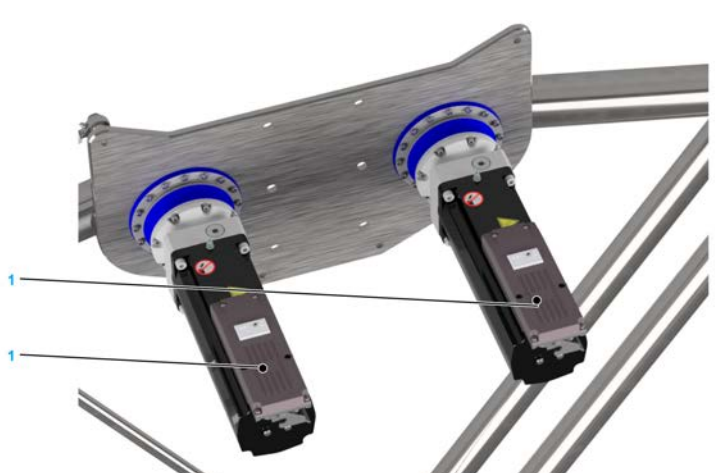
Step	Action
1	<p>For each of the two main motors (1), feed one hybrid cable from a Distribution Box ILM62DB and connect them to the motors.</p>  <p>NOTE: For equipment that you are supplying that are not described in the present document, consult the documentation for those products.</p>
2	Verify the correct routing and fastening of the cables.

⚡ ⚠ DANGER

ELECTRIC SHOCK DUE TO LOOSE WIRING OR CABLING



Tighten wiring or cabling connections in conformance with the torque specifications.

Failure to follow these instructions will result in death or serious injury.

For further information, refer to *Lexium 62 Hardware Guide* or *Lexium 52 Hardware Guide*.

Grounding the Robot

NOTE: When grounding the robot, use cables that comply with the applicable local standards, for example, cables that conform to NEC 70 / NFPA 79 in the USA.

Step	Action
1	<p>Fasten the ground cables to the ground connections (1) of the robot motors. The ground connections are marked with the following symbol:</p>  <p>Tightening torque: 2.9 Nm (25.7 lbf-in)</p>  <p>NOTE:</p> <ul style="list-style-type: none"> • The graphic is an example for the position of the ground connection at a main axis motor. • The external protective ground connection wiring is determined by a number of variables. <div style="border: 1px solid black; padding: 5px; margin-top: 10px;"> <p style="text-align: center;">⚡ ⚠ DANGER</p> <p>ELECTRIC SHOCK DUE TO IMPROPER GROUNDING</p> <ul style="list-style-type: none"> • Ground robot components in accordance with local, regional and/or national standards and regulations at a single, central point. • Verify that the motors are connected to the ground plane of the application. <p>Failure to follow these instructions will result in death or serious injury.</p> </div> <p>Multipoint grounding is permissible if connections are made to an equipotential ground plane dimensioned to help avoid cable shield damage in the event of power system short-circuit currents.</p>
2	Verify the correct routing and fastening of the cables.

Reducing Risks Around the Robot

Step	Action
1	Install external safety-related devices in accordance to local regulations and standards.
2	<p>When designing the safety-related devices, assume that the robot cannot be stopped by internal logic and must be stopped by the external safety-related devices.</p> <p>NOTE: More information about the circuitry of emergency stop and additional protection elements is contained in the document <i>Lexium 52 Hardware Guide</i>, <i>Lexium 62 Hardware Guide</i>, or <i>Lexium 62 ILM Hardware Guide</i>.</p>

Initial Start-Up

Allocation of the Sercos Addresses

Presentation

Allocate the Sercos addresses of the servo amplifiers on the two main axes in ascending order. First allocate A and then allocate B (refer to the engraved letters on the mounting plate).

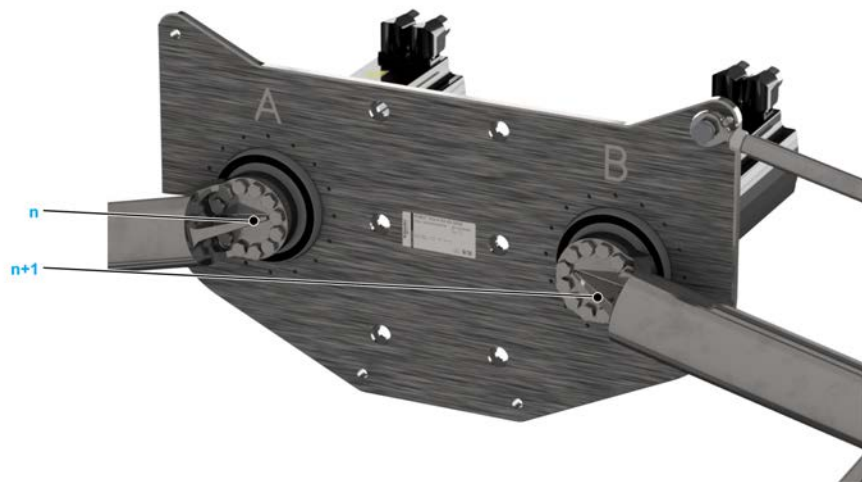

Parametrization of the Robot Mechanics

Parametrization of the Robot Mechanics by Means of the SchneiderElectricRobotics Library

Use the `SchneiderElectricRobotics` library for operating the Lexium T robot. The `SchneiderElectricRobotics` library facilitates the parametrization and increases the possible payload, the accuracy, and the performance of the system.

For further information about using the `SchneiderElectricRobotics` library, refer to *SchneiderElectricRobotics Library Guide* in the EcoStruxure Machine Expert online help.

Manual Parametrization of the Robot Mechanics

Depending on the application, individual values may or must be adapted or optimized. This must be effected relative to the payload, path, permissible tracking deviation, and other relevant parameters.

Mounting the Lower Arms with Parallel Plate

Overview

In the following procedures, the single lower arm with parallel plate is mounted to the right side and the double lower arm is mounted to the left side of the robot (see the following figure). Alternatively, you can switch the mounting sides of the single lower arm with parallel plate and the double lower arm.



For further information on changing the mounting sides, contact your local Schneider Electric service representative.

Mounting the Single Lower Arm with Parallel Plate

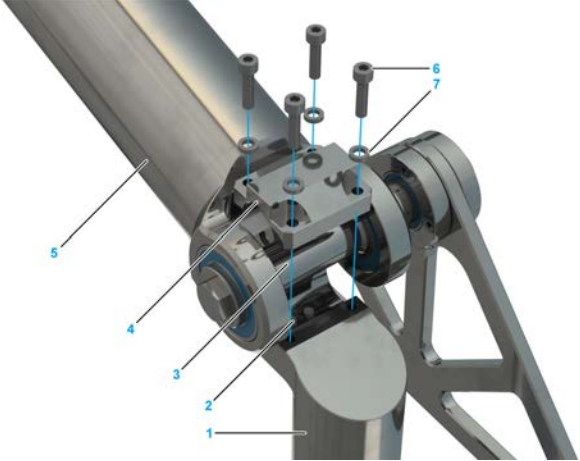
Step	Action
1	Verify that the premounted combination of the lower arms and the parallel plate shows no visible signs of transport damage. NOTE: If there are visible signs of transport damage, replace the parts.
2	Push the single lower arm (1) with its upper end to the mid of the upper arm (5). 
3	Verify that the two pins (2) of the lower arm are fitting correctly into the upper arm shaft (3).
4	Attach the half shell (4) to the lower arm and tighten it with four screws (6) and four lock washers (7). Tightening torque: 4.7 Nm (42 lbf-in)

Mounting Double Lower Arms with Parallel Plate

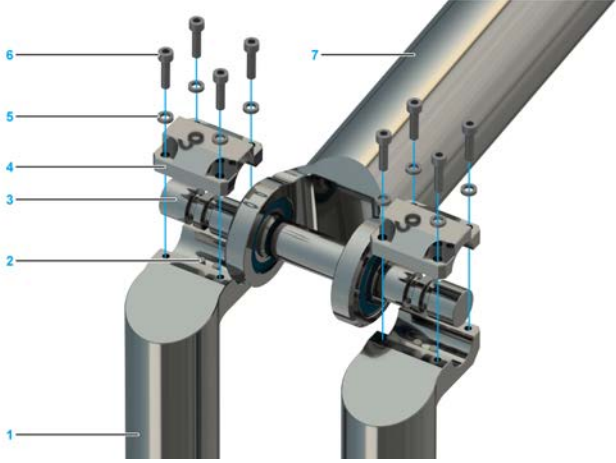
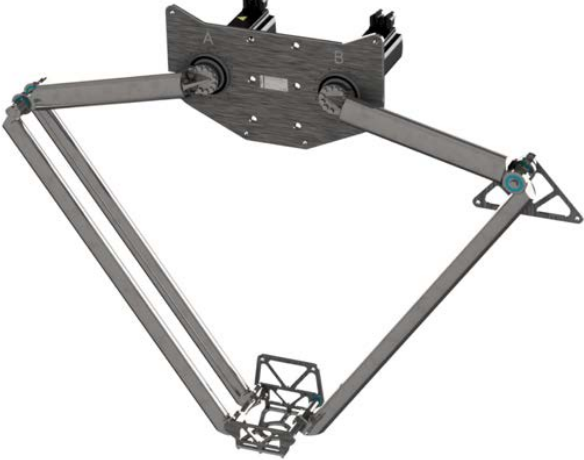
Step	Action
1	<p>Push both lower arms (1) with their upper ends to the left and right of the upper arm (7).</p> 
2	<p>Verify that the two pins (2) of both lower arms are fitting correctly into the upper arm shaft (3).</p>
3	<p>Attach the two half shells (4) to the lower arms and tighten each one with four screws (6) and four lock washers (5).</p> <p>Tightening torque: 4.7 Nm (42 lbf-in)</p>
4	<p>Verify that the robot configuration corresponds to the following figure.</p>  <p>NOTE: Alternatively, the mounting sides of the single lower arm and the double lower arm can be switched.</p>

Mounting the Rods for the Parallel Linkage

Mounting the Short Rod

Step	Action
1	Verify that the short rod shows no visible signs of transport damage. NOTE: If there are visible signs of transport damage, replace the parts.
2	Fasten one end of the short rod (2) to the mounting plate (1) and the other end to the lever parallel linkage (3). Tightening torque: 56 Nm (496 lbf-in)
	
3	Verify the position of the lever parallel linkage.

Mounting the Long Rod

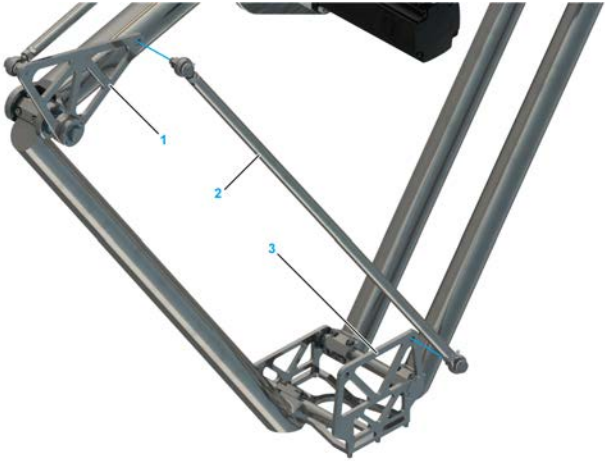
Step	Action
1	Verify that the long rod shows no visible signs of transport damage. NOTE: If there are visible signs of transport damage, replace the parts.
2	Fasten one end of the long rod (2) to the lever parallel linkage (1) and the other end to the parallel plate (3). Tightening torque: 56 Nm (496 lbf-in)
	
3	Verify the position of the parallel plate.

Setting the Monitoring

Operating Library

Use the `SchneiderElectricRobotics` and `RoboticModule` library for operating the Lexium T robot.

Software Limits for Working Area

For the definition of application-specific software limits, refer to EcoStruxure Machine Expert online help.

Verifying the Brake Voltage

Verify the brake voltage as an incorrect voltage may cause premature wear of the brakes.

For further information, observe the respective operating instructions of the motors:

- VRKT•M: *MH3 Servo motor Motor Manual*
- VRKT•L: *Lexium 62 ILM Hardware Guide*

Testing the Additional Protective Devices

- Verify the emergency stop, operator protective device, and device for releasing the brakes.
- Comply with the relevant standards, and design the protective devices to stop the robot without leaving the path (Safe Stop 1 (SS1), synchronous).

For further information, refer to *Lexium 52 Hardware Guide* or *Lexium 62 Hardware Guide*.

Verifying the Monitoring

- Slowly move the robot beyond the limits of the preset working space in order to verify that this is prevented by the preset monitoring.
- Individually move the arms beyond the maximum/minimum angles in order to verify that this is prevented by the preset monitoring.

Verifying the Installation

Procedure Overview

Perform the following steps to verify the installation:

- Verifying the calibration, page 89
- Verifying the motor direction of rotation, page 90
- Verifying the coordinate system of the robot, page 90

Verifying the Calibration

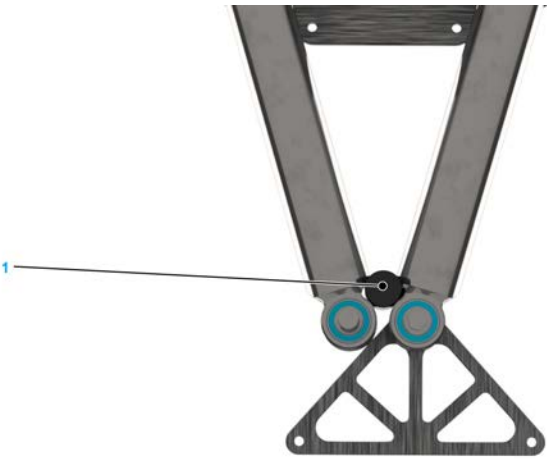
Step	Action
1	<p>Mount the calibration tool (1) to one of the upper arms.</p> 
2	Open the brakes.
3	Carefully rotate both upper arms inwards until the calibration tool has contact with both arms as shown in the figure above (calibration position).
4	<p>Verify that the angle of both upper arms indicated is:</p> <ul style="list-style-type: none"> • For VRKT1: -101.83° ($\pm 0.1^\circ$) • For VRKT2: -114.31° ($\pm 0.1^\circ$) • For VRKT3: -110.75° ($\pm 0.1^\circ$) • For VRKT5: -106.12° ($\pm 0.1^\circ$) <p>For further information, refer to <i>Calibration of the Robot Mechanics</i>, page 118.</p>
5	Move the arms outwards again until they are in a horizontal position (motor position approximately 0°).

Verifying the Motor Direction of Rotation

Step	Action
1	Slowly move the upper arms in manual mode, upwards and downwards. NOTE: Upwards (mathematically) is a positive change of an angle and downwards (mathematically) is a negative change of an angle.
2	Verify that the direction of rotation is correct.
3	Verify that the parameterized motor moves and the motors A and B are arranged as shown in the following figure.

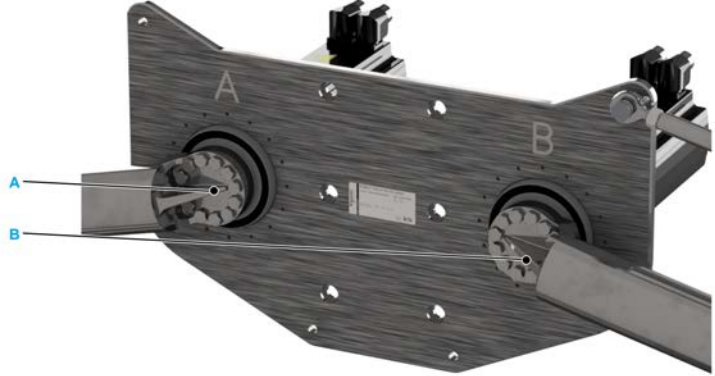

For further information, refer to *Allocation of the Sercos Adresses*, page 84.

Verifying the Coordinate System of the Robot

Step	Action
1	Slowly move the robot in manual mode in the direction of an axis of the coordinate system.
2	Verify that the robot moves in a straight line in the direction of the axis.
3	Verify that the robot moves in a straight line in a positive or negative direction of the coordinate system.
4	Repeat the process for all axes of the coordinate system.

In case the robot does not move in a straight line on the path, proceed as follows:

Step	Action
1	Select the robot type when using the <code>SchneiderElectricRobotics</code> library.
2	When not using the <code>SchneiderElectricRobotics</code> library, verify the correct parameterization of the transformation and the axes.
3	Verify the calibration, page 89.
4	Verify the direction of rotation of the drives, page 90.
5	Calibrate the robot if required, page 118.

In case the robot moves along a straight line but not in the direction of the required coordinate system, proceed as follows:

Step	Action
1	Verify the definition of the coordinate system on the transformation.
2	Verify the definition of the motors in the correct sequence, page 90.

Start-Up

Overview

When the robot is operated for the first time, there is a risk of unintended equipment operation caused by possible wiring errors or unsuitable parameters.

⚠ WARNING
<p>UNINTENDED EQUIPMENT OPERATION</p> <ul style="list-style-type: none"> • Verify that the robot is properly fastened so it cannot come loose even during fast acceleration. • Take all necessary measures to ensure that the moving parts of the robot cannot move in an unanticipated way. • Verify that emergency stop equipment is operational and within reach of the zone of operation. • Verify that the system is free and ready for the movement before starting the system. • Run initial tests at reduced velocity. <p>Failure to follow these instructions can result in death, serious injury, or equipment damage.</p>

If the motor power supply is disabled unintentionally, for example as a result of power interruption, errors or functions, the motor is no longer decelerated in a controlled way.

⚠ WARNING
<p>UNINTENDED EQUIPMENT OPERATION</p> <p>Verify that movements without braking effect cannot cause injuries or equipment damage.</p> <p>Failure to follow these instructions can result in death, serious injury, or equipment damage.</p>

The metal surfaces of the robot may exceed 70 °C (158 °F) during operation. For further information, refer to *Hot Surfaces*, page 19.

NOTE: Perform a start-up for an already configured robot when using the robot under modified operating conditions. For further information, refer to *Hazard Information*, page 12.

Commissioning Procedure

Step	Action
1	Verify the installation, page 89.
2	Comply with the instructions provided in the manual of the motor used and in the manual of the drives used.
3	Verify that the load conforms to the specified payloads for the robot before operating the robot.
4	Limit the maximum torque of the motor in accordance with the maximum drive torque of the robot.
5	Perform initial tests at reduced velocity.
6	Verify that the ambient conditions, page 30, conform to the appropriate specified conditions for the robot.

Mounting the Payload

Mounting the Gripper

Mounting the Gripper at VRKT1, VRKT2, VRKT3, VRKT5

Step	Action
1	<p data-bbox="614 432 1433 483">Fasten the gripper to the mounting points provided for this purpose on the parallel plate (1):</p> <ul data-bbox="614 488 1433 539" style="list-style-type: none"> <li data-bbox="614 488 1433 539">• Pitch circle diameter 79 mm (3.1 in): 8 x M4 (2), tightening torque: 2.2 Nm (19.5 lbf-in); property class of the screws 8.8 or greater or A4-80 or greater. <p data-bbox="614 544 1433 573">Use a medium strength threadlocking adhesive, such as Loctite 243, for this purpose.</p> <p data-bbox="614 589 1433 618">For further information, refer to <i>Flange Dimensions for Lexium T Robots</i>, page 93.</p>  <p data-bbox="660 1070 730 1093">NOTE:</p> <ul data-bbox="660 1104 1439 1236" style="list-style-type: none"> <li data-bbox="660 1104 1439 1155">• Observe the permissible weights and distances. For further information, refer to <i>Mechanical and Electrical Data</i>, page 32. <li data-bbox="660 1160 1439 1236">• The maximum tilting torque at the parallel plate is 20 Nm (177 lbf-in) for VRKT1 and 175 Nm (1549 lbf-in) for VRKT2, VRKT3, VRKT5. For further information, refer to <i>Load Capacity Diagram</i>, page 57.

Flange Dimensions for Lexium T Robots

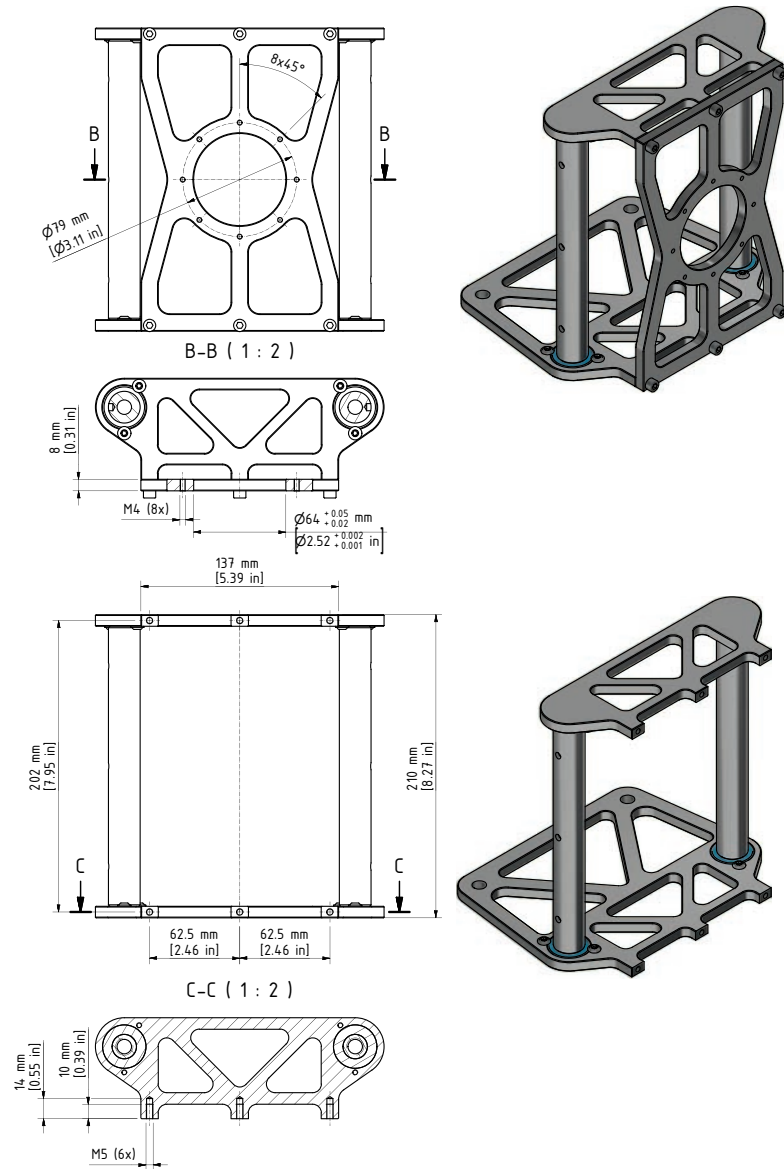

Mounting a Rotational Drive Unit

Overview

You can mount a gearbox/motor combination at the mounting points for the gripper. This unit could be used for rotating an attached gripper or drive mechanical components inside an end-effector system. The appropriate combination of motor and gearbox has to be determined according to the application specifications. The mounting flange is compatible with many commonly used gearboxes.

Mounting a Rotational Drive Unit

Step	Action
1	<p>Fasten the gearbox (1) to the mounting points provided for this purpose on the parallel plate (2).</p> <ul style="list-style-type: none"> • Pitch circle diameter 79 mm (3.1 in): 8 x M4 (3), tightening torque: 2.2 Nm (19.5 lbf-in); property class of the screws 8.8 or greater or A4-80 or greater.  <p>NOTE:</p> <ul style="list-style-type: none"> • Observe the permissible weights and distances. For further information, refer to <i>Mechanical and Electrical Data</i>, page 32. • The maximum tilting torque at the parallel plate is 20 Nm (177 lbf-in) for VRKT1 and 175 Nm (1549 lbf-in) for VRKT2, VRKT3, VRKT5. For further information, refer to <i>Load Capacity Diagram</i>, page 57.
2	<p>Ground the gearbox/motor combination in accordance with local standards and regulations at a single, central point.</p> <p>NOTE: When grounding the robot, use cables that comply with the applicable local standards, for example, cables that conform to NEC 70 / NFPA 79 in the USA.</p> <div style="border: 1px solid black; padding: 5px; margin: 10px 0;"> <p style="text-align: center;">⚡ ⚠ DANGER</p> <p>ELECTRIC SHOCK DUE TO IMPROPER GROUNDING</p> <ul style="list-style-type: none"> • Ground robot components in accordance with local, regional and/or national standards and regulations at a single, central point. • Verify that the motors are connected to the ground plane of the application. <p>Failure to follow these instructions will result in death or serious injury.</p> </div> <p>Multipoint grounding is permissible if connections are made to an equipotential ground plane dimensioned to help avoid cable shield damage in the event of power system short-circuit currents.</p>

Supply of the Gripper

Feeding the Media to the Gripper

Feed in the media line from cables, hoses, and so on, via the upper and lower arms to the parallel plate.

NOTE: Ensure that additional loads on the upper and lower arms are minimal. Distribute additional loads to different arms, if possible. Attach the additional loads to the lower arms to help avoid damage to the arms due to dynamic forces.

<i>NOTICE</i>
HIGH WEAR AND/OR DAMAGED BEARINGS Distribute loads to lower arms in a way that minimizes the rotational forces on the arms. Failure to follow these instructions can result in equipment damage.

Maintenance and Repair

What's in This Chapter

Maintenance, Repair, and Cleaning	96
Replacing Parts.....	105
Calibration	118

Maintenance, Repair, and Cleaning

General Information About Maintenance, Repair, and Cleaning

Overview

The use and application of the information contained herein require expertise in the design and programming of automated control systems. Only you, the user, machine builder or integrator, can be aware of all the conditions and factors present during installation and setup, operation, repair, and maintenance of the machine or process.

You must also consider any applicable standards and/or regulations with respect to grounding of all equipment. Verify compliance with any safety information, different electrical requirements, and normative standards that apply to your machine or process in the use of this equipment.

DANGER

ELECTRIC SHOCK, EXPLOSION, OR ARC FLASH

- Disconnect all power from all equipment including connected devices prior to removing any covers or doors, or installing or removing any accessories, hardware, cables, or wires except under the specific conditions specified in the appropriate hardware guide for this equipment.
- Always use a properly rated voltage sensing device to confirm that the power is off where and when indicated.
- Replace and secure all covers, accessories, hardware, cables, and wires and confirm that a proper ground connection exists before applying power to the equipment.
- Use only the specified voltage when operating this equipment and any associated products.
- After switching off the equipment make sure to maintain a waiting time of at least 15 minutes before disconnecting the power cable for the capacitors to discharge.
- Operate electrical components only with a connected protective ground (earth) cable.
- Verify the secure connection of the protective ground (earth) cable to the electrical devices so that connection complies with the wiring diagram.
- Do not touch the electrical connection points of the components when the equipment is energized.
- Provide protection against indirect contact.
- Insulate any unused conductors on both ends of the connection cable.
- Ensure that the power cables are correctly connected and connectors are locked in place during the operation time of the system.

Failure to follow these instructions will result in death or serious injury.

Poor maintenance can lead to premature wear, or even present potential safety hazards for production or maintenance operators.

▲ WARNING

UNINTENDED EQUIPMENT OPERATION

Develop and follow a maintenance plan and associated protocols adapted to the requirements of your application and equipment.

Failure to follow these instructions can result in death, serious injury, or equipment damage.

Servicing

In case of issues which cannot be resolved, contact your local Schneider Electric service representative with the following information:

- Type plate information (type, identification number, serial number, DOM)
- Detailed description of the issue
- Previous and associated circumstances

Maintenance Plan

Overview

The maintenance intervals may have to be adapted to the greatly varying operational hours depending on the application.

For procedures to replace the different parts, refer to *Replacing Parts*, page 105.

Maintenance Schedule

Interval	Action
Every 150 hours of operation or weekly	<ul style="list-style-type: none"> Verify the robot by visual inspection for any damage or missing parts, especially moving parts and parts at risk for collisions such as grippers, upper arms, lower arms, parallel plate, or parallel linkage rods. Replace the arms or the parallel linkage rods if these are bent or dented. Clean the robot mechanics.
Every 1,000 hours of operation or every three months	<ul style="list-style-type: none"> Verify all moving parts for bolted connections. Verify the output shaft sealing of gearboxes for deposits of dirt and clean.
Every 3,000 hours of operation or every six months	<ul style="list-style-type: none"> Verify the arm bearings and replace them if necessary. Verify the parallel plate bearings and replace them if necessary. Verify the bearing lever parallel linkage and replace them if necessary.
Annually	<ul style="list-style-type: none"> Verify the parallel rod system and replace or lubricate the ball ends of the parallel rods with a grease gun if necessary. Verify the brake function during operation.
Every 20,000 hours of operation	<ul style="list-style-type: none"> Replace the main gearboxes and motors.
Every 40,000 hours of operation	<ul style="list-style-type: none"> Replace the upper arms.
Every 1,000 emergency stop situations	<ul style="list-style-type: none"> Replace the upper arms.

NOTE: The gearbox and the bearings have been lubricated for life.

Maintaining the Upper Arm Bearings

Overview

Periodically verify and replace the upper arms with mounted ball bearings in accordance with the maintenance schedule, page 98.

Small amounts of grease at the ball bearings do not constitute damage. Carefully remove deposits at the bearing seals using a lint-free cloth.

NOTICE	
DAMAGED BEARINGS	
<ul style="list-style-type: none"> • Use a lint-free cloth for cleaning. • Do not clean dry deposits using compressed air. • Do not use solvents such as trichloroethylene, tetrachloromethane, or hydrocarbons nor sharp-edged objects, emery cloth, or emery paper. • Minimize the mechanical impacts when cleaning. 	
Failure to follow these instructions can result in equipment damage.	

Verifying the Wear of the Upper Arm Bearings

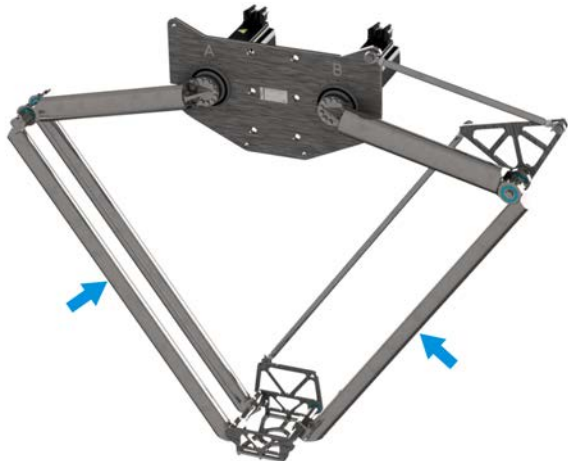
Step	Action
1	<p>NOTE: Do not remove the robot arm for this verification.</p> <p>Move both upper arms in a horizontal position.</p>
2	<p>Verify the bearings for backlash by pushing and pulling the lower arms perpendicular to the robot working area (apply about 30 N (6.7 lbf) at the middle of the lower arm).</p> <p>NOTE: When testing, differentiate between the real backlash of the system as opposed to the resistance of the components to movement.</p> <div style="text-align: center;">  </div>
3	<p>Replace the upper arm with mounted ball bearings if the noticed backlash exceeds the needs of your application.</p> <p>For further information, refer to <i>Replacing the Upper Arms</i>, page 111.</p>

Maintaining the Parallel Plate Bearings

Overview

Periodically verify and replace the parallel plate bearings in accordance with the maintenance schedule, page 98.

Small amounts of grease at the ball bearings do not constitute damage. Carefully remove deposits at the bearing seals using a lint-free cloth.

NOTICE

DAMAGED BEARINGS

- Use a lint-free cloth for cleaning.
- Do not clean dry deposits using compressed air.
- Do not use solvents such as trichloroethylene, tetrachloromethane, or hydrocarbons nor sharp-edged objects, emery cloth, or emery paper.
- Minimize the mechanical impacts when cleaning.

Failure to follow these instructions can result in equipment damage.

Verifying the Wear of the Parallel Plate Bearings

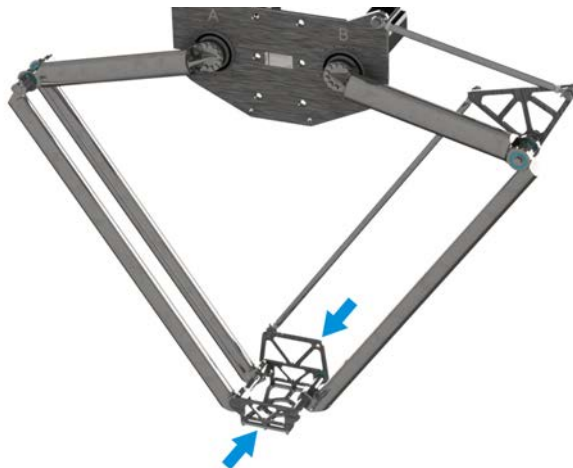
Step	Action
1	<p>NOTE: Do not remove the robot arm for this verification.</p> <p>Move both upper arms in a horizontal position.</p>
2	<p>Verify the bearings for backlash by pushing, pulling and tilting the parallel plate (apply about 10 N (2.25 lbf) in the middle of the parallel plate).</p> <p>NOTE: When testing, differentiate between the real backlash of the system as opposed to the resistance of the components to movement.</p> 
3	<p>Replace the parallel plate bearings if the noticed backlash exceeds the needs of your application.</p> <p>For further information, refer to <i>Replacing the Parallel Plate Bearings</i>, page 108.</p>

Maintaining the Parallel Rod System

Overview

Periodically verify and replace the parallel rods in accordance with the maintenance schedule, page 98.

Small amounts of grease at the ball end bearings do not constitute damage. Carefully remove deposits at the bearing seals using a lint-free cloth.

NOTICE	
DAMAGED BEARINGS	
<ul style="list-style-type: none"> • Use a lint-free cloth for cleaning. • Do not clean dry deposits using compressed air. • Do not use solvents such as trichloroethylene, tetrachloromethane, or hydrocarbons nor sharp-edged objects, emery cloth, or emery paper. • Minimize the mechanical impacts when cleaning. 	
Failure to follow these instructions can result in equipment damage.	

Verifying the Wear of the Parallel Rod Ball End Bearings

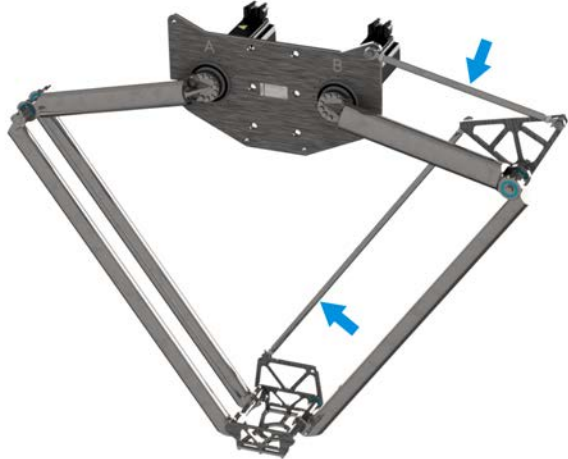
Step	Action
1	<p>NOTE: Do not remove the robot arm for this verification.</p> <p>Move both upper arms in a horizontal position.</p>
2	<p>Verify the bearings for backlash by pushing and pulling both parallel rods perpendicular to the robot working plane (apply about 30 N (6.7 lbf) at the middle of the rods).</p> <p>NOTE: When testing, differentiate between the real backlash of the system as opposed to the resistance of the components to movement.</p> <div style="text-align: center;">  </div>
3	<p>Replace the parallel rod if the noticed backlash exceeds the needs of your application.</p> <p>For further information, refer to <i>Replacing the Parallel Rods</i>, page 110.</p>

Lubricating the Parallel Rod System

Apply grease by using a grease gun to the grease nipple, DIN 71412 H1 (minimum size 12).

NOTE: Use aluminum-complex-soap grease, approved according to USDA H1.

Temperature range: -45...+120 °C (-49...+248 °F)

Maintaining the Motor (Optional Equipment)

Overview

For information about maintaining the motor, record the motor reference on the type plate and refer to the corresponding motor manual.

Maintaining the Gearbox

Step	Action
1	Verify the gearbox by visual inspection for leakages and deposits of dirt on the gearbox output shaft sealing periodically in accordance with the maintenance schedule, page 98.
2	Carefully remove deposits. Use lint-free cloths to clean the gearbox. NOTE: In case of a leakage, contact your local Schneider Electric service representative.

NOTICE

DAMAGED GEARBOXES DUE TO INAPPROPRIATE CLEANING OF THE GEARBOX

- Use lint-free cloth for cleaning.
- Do not clean dry deposits using compressed air.
- Do not use solvents; for example, trichloroethylene, tetrachloromethane, or hydrocarbons nor sharp-edged objects, emery cloth, or emery paper.
- Minimize the mechanical impacts when cleaning.

Failure to follow these instructions can result in equipment damage.

Cleaning

Overview

Care must be taken with cleaning products as some active agents may have harmful effects on plastics and stainless steel.

NOTICE
<p>CORROSION CAUSED BY CLEANING AGENTS</p> <ul style="list-style-type: none"> • Perform a compatibility test in relation to the cleaning agent and the component affected before using a cleaning agent. • Do not use alkaline detergent in the interior of the mechanics. • Do not use any chloride-containing cleaning agents. • Do not use any sulphuric acid containing detergent. <p>Failure to follow these instructions can result in equipment damage.</p>

For further information about the material properties of your components, refer to *Mechanical and Electrical Data*, page 32.

NOTE: Depending on the operating conditions and requirements, cleaning may be necessary on a more frequent basis.

Cleaning the Robot

Step	Action
1	Use cleaning processes appropriate to the degree of protection, page 32 of the robot.
2	Allow the cleaning agent to act for a short time.
3	Thoroughly rinse the robot with water.
4	Clean the robot on a weekly basis in order to help to avoid that abrasions accumulate and pass into production.

Cleaning the Bearings of Moving Parts

NOTE: Particularly in the first hours of operation, a slight sweating of the bearings may occur. This is a result of the manufacturing process and does not constitute damage on the bearings.

Only clean the bearings and seals by wiping with a lint-free cloth or wash-down at low pressure. For further information, refer to *Maintaining the Upper Arm Bearings*, page 99, *Maintaining the Parallel Plate Bearings*, page 100 and *Maintaining the Parallel Rod System*, page 101.

Cleaning the Gearbox

NOTE: Particularly in the first hours of operation, a slight sweating of the gearboxes may occur. This is a result of the manufacturing process and does not constitute damage on the gearboxes.

Only clean the gearbox flanges and seals by using wiping with lint-free clothes or wash-down at low pressure. For further information, refer to *Maintaining the Gearbox*, page 102.

Repairing After Collisions

Overview

Components may be damaged as a result of a collision.

▲ WARNING
<p>FALLING OR EJECTED PARTS</p> <ul style="list-style-type: none"> • Thoroughly inspect all components of the robot and all components attached to the robot, including the motor and the gearbox, for damage after a collision. • Do not use the robot if any of the components are damaged or suspected to be damaged. <p>Failure to follow these instructions can result in death, serious injury, or equipment damage.</p>

Verifying the Robot After a Collision

NOTICE
<p>COLLISION OF COMPONENTS</p> <p>Replace upper arms, lower arms and/or parallel rods if dents or cracks are observed or otherwise detected.</p> <p>Failure to follow these instructions can result in equipment damage.</p>

Step	Action
1	Verify the components for completeness. If any components are missing, locate the same and remove them from the surrounding machinery.
2	Replace damaged or missing components.
3	Verify the upper arms, lower arms and parallel rods for visible dents or cracks. Dents reduce the strength of the arms and may cause component breakdown.
4	Verify the calibration, page 118 by moving the upper arms to the calibration tool. NOTE: If the tolerance requirements for calibration are not met, replace the upper arms.
5	Verify the lower arms and the parallel rods for straightness.
6	Release the brakes and manually move the robot to verify the ease of operation.
7	Close the brakes and verify that there is a small backlash in the gearboxes and no cracking noises.

In case of other repairs beyond those described in the present document, contact your local Schneider Electric service representative.

Replacing Parts

Information About Replacing Parts

Overview

The use and application of the information contained herein require expertise in the design and programming of automated control systems. Only you, the user, machine builder or integrator, can be aware of all the conditions and factors present during installation and setup, operation, repair, and maintenance of the machine or process.

You must also consider any applicable standards and/or regulations with respect to grounding of all equipment. Verify compliance with any safety information, different electrical requirements, and normative standards that apply to your machine or process in the use of this equipment.

⚠️⚠️ DANGER

ELECTRIC SHOCK, EXPLOSION, OR ARC FLASH

- Disconnect all power from all equipment including connected devices prior to removing any covers or doors, or installing or removing any accessories, hardware, cables, or wires except under the specific conditions specified in the appropriate hardware guide for this equipment.
- Always use a properly rated voltage sensing device to confirm that the power is off where and when indicated.
- Replace and secure all covers, accessories, hardware, cables, and wires and confirm that a proper ground connection exists before applying power to the equipment.
- Use only the specified voltage when operating this equipment and any associated products.
- After switching off the equipment make sure to maintain a waiting time of at least 15 minutes before disconnecting the power cable for the capacitors to discharge.
- Operate electrical components only with a connected protective ground (earth) cable.
- Verify the secure connection of the protective ground (earth) cable to the electrical devices so that connection complies with the wiring diagram.
- Do not touch the electrical connection points of the components when the equipment is energized.
- Provide protection against indirect contact.
- Insulate any unused conductors on both ends of the connection cable.
- Ensure that the power cables are correctly connected and connectors are locked in place during the operation time of the system.

Failure to follow these instructions will result in death or serious injury.

The robot heats up significantly when subjected to heavy loads and/or high performance.

The metal surfaces of the robot may exceed 70 °C (158 °F) during operation. For further information, refer to *Hot Surfaces*, page 19.

Replacing the Lower Arms

⚠ WARNING

FALLING HEAVY LOAD

Secure in place the parallel plate and lower arm when loosening and removing the screws.

Failure to follow these instructions can result in death, serious injury, or equipment damage.

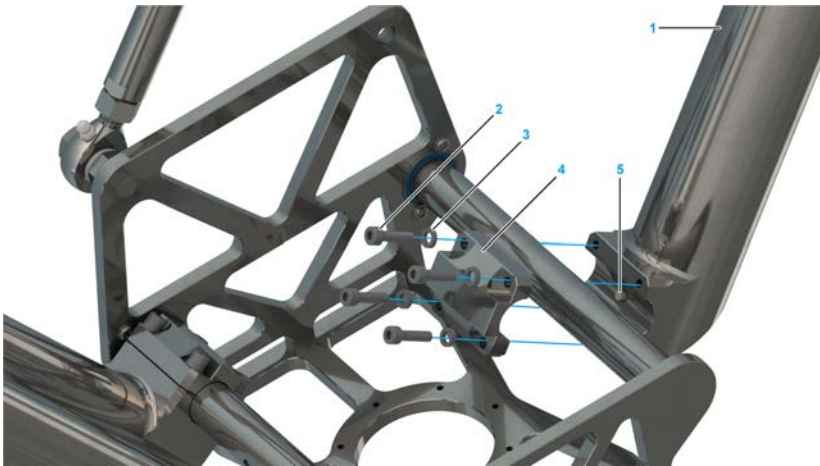
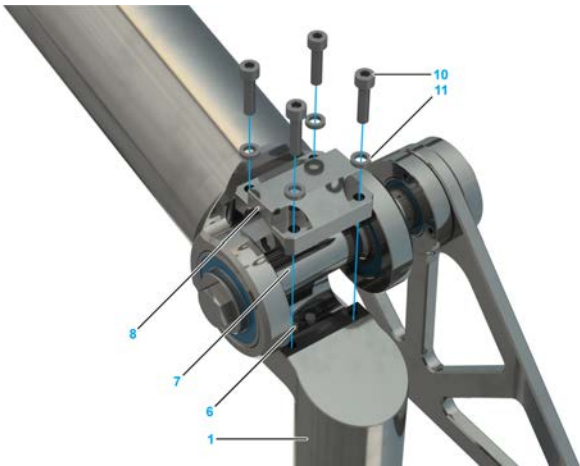
Step	Action
1	<p>Carefully remove the four screws (2) and the four lock washers (3) from the lower half shell at the lower arm (1) and then remove the shell (4).</p>  <p>NOTE: Take care that the indexing bolts (5) of the lower arm are located inside the holes of the shaft of the upper arm.</p>
2	<p>Carefully remove the four screws (10) and the four lock washers (11) from the upper half shell (8) at the lower arm (1) and then remove the shell.</p>  <p>NOTE: Take care about the indexing bolts (6) of the lower arm.</p>
3	<p>Replace the lower arm and mount the shells in reverse order.</p> <p>For further information, refer to <i>Mounting the Lower Arms with Parallel Plate</i>, page 85.</p>



Replacing the Parallel Plate

⚠ WARNING

FALLING HEAVY LOAD

Secure in place the parallel plate and lower arm when loosening and removing the screws.

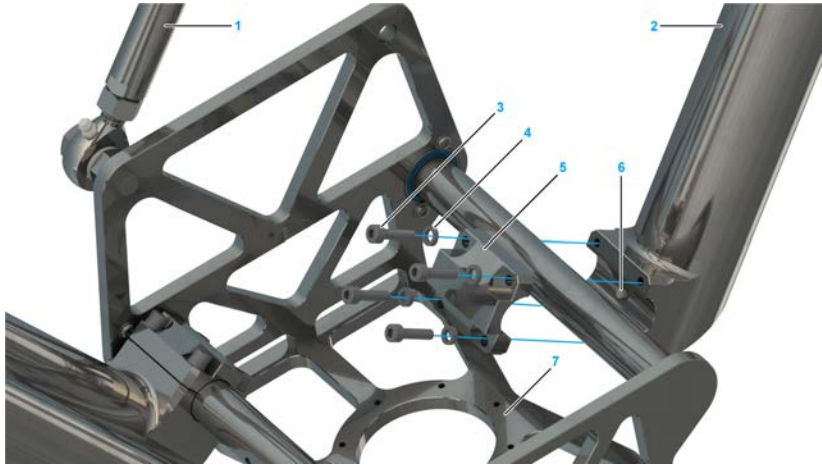
Failure to follow these instructions can result in death, serious injury, or equipment damage.

Step	Action
1	<p>Remove the long rod (1) from the parallel plate (7).</p> 
2	<p>Carefully remove the four screws (3) and the four lock washers (4) from the lower half shell (5) at the lower arm (2) and then remove the shell. Repeat this step for all lower arms.</p> <p>NOTE: Take care that the indexing bolts (6) of the lower arm are located inside the holes of the shaft of the upper arm.</p>
3	<p>Mount the new parallel plate to the lower arms.</p> <p>Tightening torque: 4.7 Nm (42 lbf-in)</p> <p>NOTE: Ensure that the parallel plate has the same orientation as before.</p>
4	<p>Mount the long rod to the parallel plate.</p> <p>Tightening torque: 56 Nm (496 lbf-in)</p>
5	<p>Slowly move the robot and verify the position of the particular articulation devices.</p> 

Replacing the Parallel Plate Bearings

⚠ WARNING

FALLING HEAVY LOAD

Secure in place the parallel plate and lower arm when loosening and removing the screws.

Failure to follow these instructions can result in death, serious injury, or equipment damage.

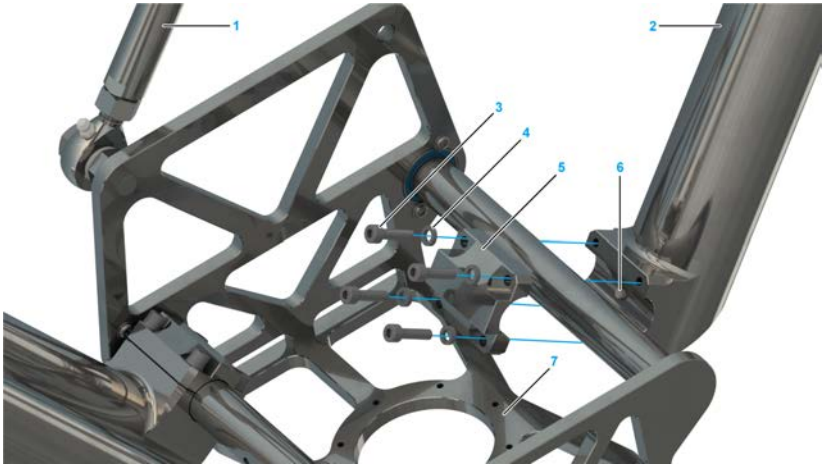
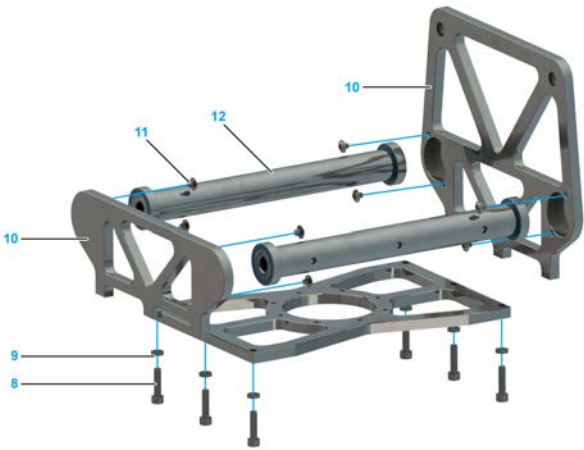
Step	Action
1	Remove the long rod (1) from the parallel plate (7). 
2	Carefully remove the four screws (3) and the four lock washers (4) from the lower half shell (5) at the lower arm (2) and then remove the shell. NOTE: Take care that the indexing bolts (6) of the lower arm are located inside the holes of the shaft of the upper arm.
3	Remove the six screws (8) and the six lock washers (9) on the bottom of the parallel plate and the eight axis fasteners (11) at the bearings. 
4	Pull off the two shafts with bearings (12) from the side plates (10).
5	Attach the two new shafts with bearings (7) to the side plates and fasten them with the eight axis fasteners. Tightening torque: 2.2 Nm (19.5 lbf-in)
6	Fasten the bottom of the parallel plate to the side plates with the six screws and the six lock washers. Tightening torque: 4.7 Nm (42 lbf-in)
7	Mount the parallel plate to the lower arms. NOTE: Ensure that the parallel plate has the same orientation as before.

Step	Action
8	Mount the long rod to the parallel plate. Tightening torque: 56 Nm (496 lbf-in)
9	Slowly move the robot and verify the position of the particular articulation devices. 



Replacing the Parallel Rods

⚠ WARNING

FALLING HEAVY LOAD

Secure in place the parallel plate and lower arm when loosening and removing the screws.

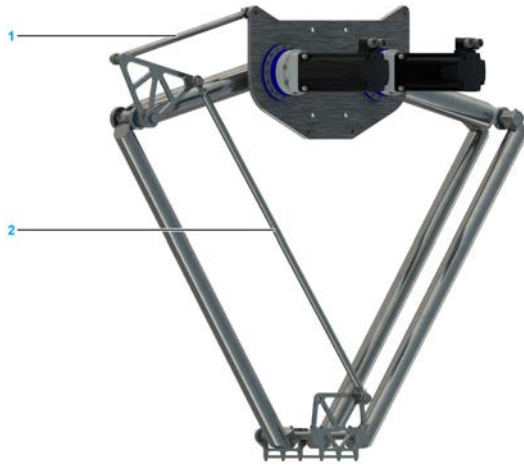
Failure to follow these instructions can result in death, serious injury, or equipment damage.

Step	Action
1	Remove the short rod (1). 
2	Remove the long rod (2).
3	Mount the new parallel rods as described in <i>Mounting the Rods for Parallel Linkage</i> , page 87.
4	Slowly move the robot and verify the position of the particular articulation devices. 



Replacing the Upper Arms

⚠ WARNING

FALLING HEAVY UPPER ARM

Secure in place the upper arm when loosening and removing the bolts.

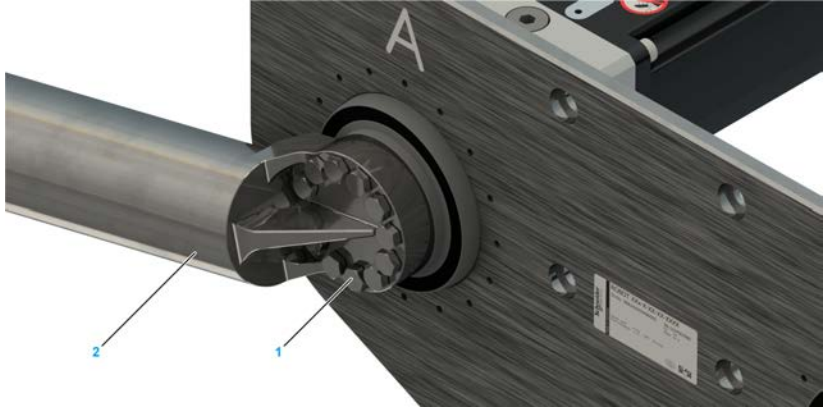
Failure to follow these instructions can result in death, serious injury, or equipment damage.

Step	Action
1	Remove the parallel rods and the lower arms with parallel plate. For further information, refer to <i>Replacing the Parallel Rods</i> , page 110 and <i>Replacing the Lower Arms</i> , page 106.
2	Remove the bolts (1) on the upper arm (2). 
3	Pull off the upper arm.
4	Verify whether the threaded pin (4) is in the hole of the gearbox. If there is no threaded pin, insert a new threaded pin at the position shown in the figure. NOTE: Verify that the threaded pin protrudes approximately 3 mm (0.118 in) 
5	Verify whether the flange surfaces of the gearbox (3) and of the upper arm are free from grease and oil. If necessary, remove grease and oil residues from the upper arm and/or the gearbox flange.
6	Attach the new upper arm to the gearbox. Tightening torque for VRKT1: 14 NM (124 lbf-in) Tightening torque for VRKT2, VRKT3, VRKT5: 22 Nm (195 lbf-in) For more information about tightening torques, bolt locking devices and installation notes, refer to the respective dimensional drawing in <i>Mechanical and Electrical Data</i> , page 32.

Step	Action
7	Calibrate the robot mechanics, page 118.
8	Mount the lower arms with parallel plate to the upper arms and mount the parallel rods. For further information, refer to <i>Mounting the Lower Arms with Parallel Plate</i> , page 85 and <i>Mounting the Rods for Parallel Linkage</i> , page 87.

⚠ WARNING

COLLISION OF COMPONENTS

- Only use the bolts that are supplied by Schneider Electric.
- Perform a calibration procedure of the robot mechanics after replacement of an upper arm, motor, or gearbox.

Failure to follow these instructions can result in death, serious injury, or equipment damage.

NOTICE

INOPERABILITY OF UPPER ARM

Remove all grease and oil residues from the gearbox flange and the upper arm.

Failure to follow these instructions can result in equipment damage.

Replacing the Protector Cap

NOTICE

INSUFFICIENT PART CLEARANCE

Ensure that the protector cap does not touch the gearbox output shaft during assembly.

Failure to follow these instructions can result in equipment damage.

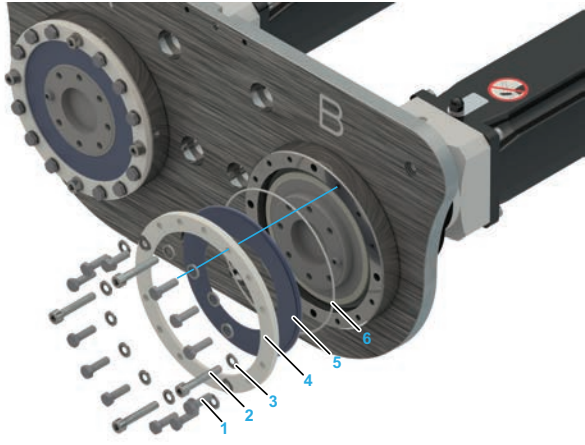
Step	Action
1	Remove the lower arms and the upper arms. For further information, refer to <i>Replacing the Lower Arms</i> , page 106 and <i>Replacing the Upper Arms</i> , page 111.
2	Remove the 12 hexagon screws (1), 4 socket head screws (2) and 16 sealing washers (3) and then remove the supporting ring (4), the protector cap (5), and the O-ring (6) from each of the two gearbox flanges. 
3	Insert the new O-ring to the intended bevel edge of the new protector cap.
4	Place the protector cap with the O-ring to the new supporting ring.
5	Place the entire unit over the gearbox output shaft on the robot and fasten it with the new screws and the new sealing washers. NOTE: Ensure that the protector cap does not come into contact with the gearbox output shaft before tightening the screws. Tightening torque: 3.5 Nm (31 lbf-in)
6	Mount the upper arms and the lower arms. For further information, refer to <i>Replacing the Upper Arms</i> , page 111 and to <i>Mounting the Lower Arms with Parallel Plate</i> , page 85.
7	<i>Calibrate the robot</i> , page 118.

Replacing the Motor or the Gearbox on the Main Axis

Overview

The use and application of the information contained herein require expertise in the design and programming of automated control systems. Only you, the user, machine builder or integrator, can be aware of all the conditions and factors present during installation and setup, operation, repair, and maintenance of the machine or process.

You must also consider any applicable standards and/or regulations with respect to grounding of all equipment. Verify compliance with any safety information, different electrical requirements, and normative standards that apply to your machine or process in the use of this equipment.

DANGER

ELECTRIC SHOCK, EXPLOSION, OR ARC FLASH

- Disconnect all power from all equipment including connected devices prior to removing any covers or doors, or installing or removing any accessories, hardware, cables, or wires except under the specific conditions specified in the appropriate hardware guide for this equipment.
- Always use a properly rated voltage sensing device to confirm that the power is off where and when indicated.
- Replace and secure all covers, accessories, hardware, cables, and wires and confirm that a proper ground connection exists before applying power to the equipment.
- Use only the specified voltage when operating this equipment and any associated products.
- After switching off the equipment make sure to maintain a waiting time of at least 15 minutes before disconnecting the power cable for the capacitors to discharge.
- Operate electrical components only with a connected protective ground (earth) cable.
- Verify the secure connection of the protective ground (earth) cable to the electrical devices so that connection complies with the wiring diagram.
- Do not touch the electrical connection points of the components when the equipment is energized.
- Provide protection against indirect contact.
- Insulate any unused conductors on both ends of the connection cable.
- Ensure that the power cables are correctly connected and connectors are locked in place during the operation time of the system.

Failure to follow these instructions will result in death or serious injury.

Procedure Overview

Perform the following procedures to replace the motor or gearbox on main axis:

- Removing the motor and the gearbox, page 115
- Removing the motor from the gearbox, page 116
- Mounting the new motor and/or the new gearbox, page 116
- Cabling the new motor and the gearbox, page 117

Removing the Motor and the Gearbox

⚠ WARNING

FALLING HEAVY LOAD

Support the motor and gearbox while removing.

Failure to follow these instructions can result in death, serious injury, or equipment damage.

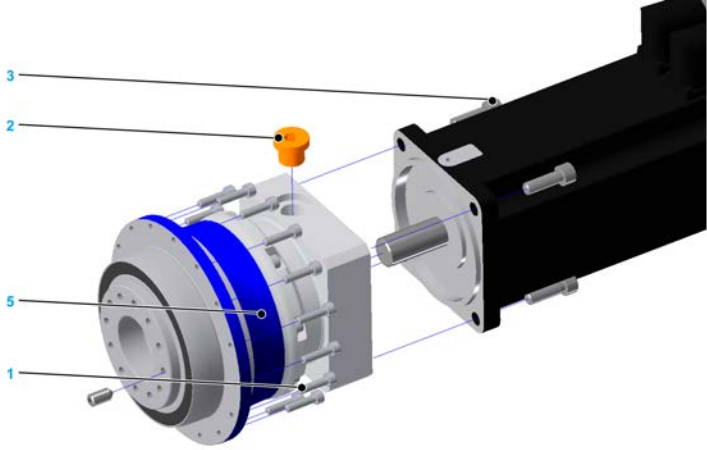
Step	Action
1	Remove the upper arm as described in <i>Replacing the Upper Arms</i> , page 111.
2	<ul style="list-style-type: none"> For robots with an MH3 motor (VRKT•M): Disconnect and remove the two motor supply cables. For robots with an ILM motor (VRKT•L): Lift up the locking device slightly of the hybrid cable and then remove the cable.
3	Disconnect and remove the ground cable from the motor.
4	Remove the 16 bolts (1) by means of which the gearbox is bolted to the mounting plate. 
5	Carefully remove the motor and gearbox (5) from the mounting plate in rearward direction. <p>NOTE: Do not tilt transmission and do not damage the alignment hole at the mounting plate.</p>

Removing the Motor from the Gearbox

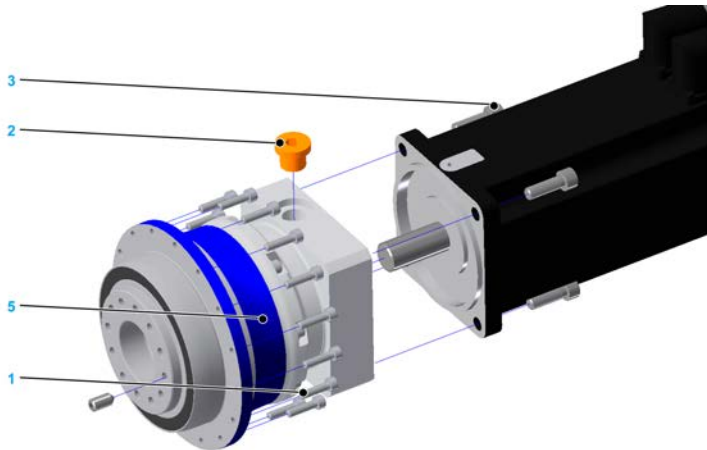
Step	Action
1	Remove the plug screw (2) on the gearbox flange. 
2	Remove the four screws (3) on the motor which connect the motor to the gearbox.
3	Carefully rotate the motor until the screw on the clamping flange appears in the aperture of the plug screw.
4	Loosen the screw in the clamping flange.
5	Carefully remove the motor from the gearbox.

Mounting the New Motor and/or the New Gearbox

NOTICE

DAMAGE TO MOTOR AND GEARBOX

Only fasten motor and gearbox with all components at the same ambient temperature.

Failure to follow these instructions can result in equipment damage.

Step	Action
1	Ensure that the gearbox and the housing are at the same temperature, as otherwise - in the case of a temperature difference - the gearbox may not fit into the aperture provided.
2	Attach the motor to the gearbox according to the specifications of the manufacturer. Tightening torques for VRKT1: <ul style="list-style-type: none"> • Clamping hub: 4.5 Nm (40 lbf-in) • Motor screws: 3.5 Nm (31 lbf-in) Tightening torques for VRKT2, VRKT3, VRKT5: <ul style="list-style-type: none"> • Clamping hub: 14 Nm (124 lbf-in) • Motor screws: 16 Nm (142 lbf-in)
3	Insert the plug screw into the gearbox flange.
4	Attach the motor/gearbox combination to the robot mounting plate in the orientation specified. Tightening torque: 4.7 Nm (42 lbf-in) For further information, refer to the respective detail drawing in <i>Mechanical and Electrical Data</i> , page 32.

▲ WARNING
<p>COLLISION OF COMPONENTS</p> <p>Calibrate the robot mechanics after the replacement of an upper arm, a motor, or a gearbox.</p> <p>Failure to follow these instructions can result in death, serious injury, or equipment damage.</p>

Cabling the Motor and the Gearbox

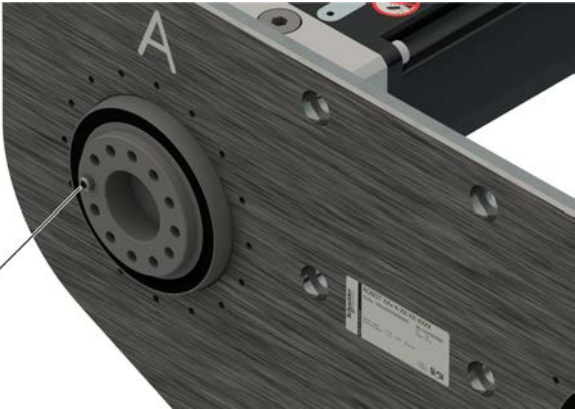
Step	Action
1	<p>Attach the ground strap to the motor.</p> <p>Tightening torque: 2.9 Nm (25.7 lbf-in)</p> <p>For further information about motor assembly, observe the respective operating instructions of the motors:</p> <ul style="list-style-type: none"> • VRKT•M: <i>MH3 Servo motor Motor Manual</i> • VRKT•L: <i>Lexium 62 ILM Hardware Guide</i>
2	Attach the motor supply cables and lock them in position.
3	<p>When using a new gearbox:</p> <p>Mount the threaded pin (1) as otherwise it may not be possible to mount the upper arm.</p> <p>NOTE: Verify that the threaded pin protrudes approximately 3 mm (0.118 in)</p> <div style="text-align: right;">  </div> <p>For further information, refer to the respective detail drawing in <i>Mechanical and Electrical Data</i>, page 32.</p>
4	Mount the upper arm as described in <i>Replacing the Upper Arms</i> , page 111.
5	Calibrate the robot mechanics, page 118.
6	<p>Mount the lower arms with parallel plate to the upper arms and mount the parallel rods.</p> <p>For further information, refer to <i>Mounting the Lower Arms with Parallel Plate</i>, page 85 and <i>Mounting the Rods for Parallel Linkage</i>, page 87.</p>

▲ WARNING
<p>COLLISION OF COMPONENTS</p> <p>Calibrate the robot mechanics after the replacement of an upper arm, a motor, or a gearbox.</p> <p>Failure to follow these instructions can result in death, serious injury, or equipment damage.</p>

Calibration

Calibration of the Robot Mechanics

Overview

The robot has been calibrated in the factory and the data/positions of the axes can be read from the motor encoders. A further alignment is not necessary. However, in a service case, calibration via the control panel may become necessary in order to restore the intended operation.

Carry Out the Calibration

Carry out the calibration in the following cases:

- Following the replacement of a component (motor, gearbox, upper arm).
- Following deletion or overwriting of the calibration data.

Calibrating the robot mechanics must be carried out by Schneider Electric personnel or qualified personnel only, as this requires an expert level of knowledge of the PacDrive System.

For this purpose, the `SchneiderElectricRobotics` library contains an interface that has the necessary modes and parameters.

⚠ WARNING

UNINTENDED EQUIPMENT OPERATION

- Calibrating the robot mechanics must be carried out by qualified personnel only.
- Conduct the calibration procedures exactly in the manner and in the order described in the present documentation.
- Use the `SchneiderElectricRobotics` library in conjunction with the calibration of robot mechanics.

Failure to follow these instructions can result in death, serious injury, or equipment damage.

Calibrating the Main Axes

Procedure Overview

Perform the following procedures to cable the robot:

- Preparing the Robot Mechanics for a Calibration Movement, page 119
- Calibrating the Main Axes, page 119

Preparing the Robot Mechanics for a Calibration Movement

Step	Action
1	Remove the parallel rods and the lower arms with parallel plate. For further information, refer to <i>Replacing the Parallel Rods</i> , page 110 and <i>Replacing the Lower Arms</i> , page 106.
2	Mount the calibration tool to one of the robot upper arms.
3	Release the brakes.

Calibrating the Main Axes

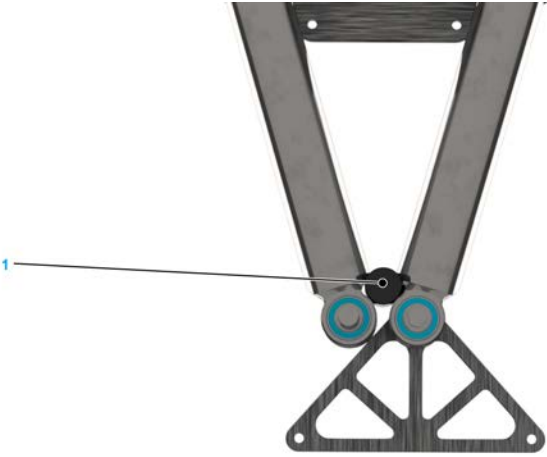
Step	Action
1	Manually move both upper arms to the calibration position so that both arms touch the calibration tool (1). 
2	Close the brakes.
3	Calibrate the main axes. For further information, <i>SchneiderElectricRobotics Library Guide</i> , Chapter <i>Using SchneiderElectricRobotics, TSeries</i> .
4	Move upper arms to a convenient position for lower arm mounting or use the calibration mode <code>MoveToMountPosition</code> of <i>SchneiderElectricRobotics</i> library.
5	Remove the calibration tool.
6	Mount the lower arms with parallel plate to the upper arms and mount the parallel rods. For further information, refer to <i>Mounting the Lower Arms with Parallel Plate</i> , page 85 and <i>Mounting the Rods for Parallel Linkage</i> , page 87.

Replacement Equipment and Accessories

What's in This Chapter

Replacement Equipment Inventory	120
Replacement Equipment of the Lexium T Robots.....	122

Replacement Equipment Inventory

Overview

Keeping a stock of important components helps ensure the availability of your machine. Only exchange devices with identical types to help ensure compatibility.

Indicate the following information on the replacement equipment order, which can be found on the logistic type plate, page 29:

Parameter	Position on type plate	Example value
Item name	First line	Robot T5m-F-NC-35-1500
Item reference (type code)	ID-No	VRKT5M0FNC00000
Hardware revision	HW	S00

Replacement Equipment Stock for Lexium VRKT1, VRKT2, VRKT3, VRKT5 Robots

When using the Lexium VRKT1, VRKT2, VRKT3, VRKT5 robots in a production environment, consider keeping the following replacement equipment packages in stock:







Item reference	Item name	Quantity*			
		VRKT1	VRKT2	VRKT3	VRKT5
VRKT1YYYYY00002	Upper arm with bearings	(1)**	0	0	0
VRKT2YYYYY00002		0	(1)**	0	0
VRKT3YYYYY00002		0	0	(1)**	0
VRKT5YYYYY00002		0	0	0	(1)**
VRKT1YYYYY00003	Gearbox main axis	(1)**	0	0	0
VRKTXYYYY-Y00003		0	(1)**	(1)**	(1)**
VRKT1YYYYY00004	Lower arm pair	(1)**	0	0	0
VRKT2YYYYY00004		0	(1)**	0	0
VRKT3YYYYY00004		0	0	(1)**	0
VRKT5YYYYY00004		0	0	0	(1)**
VRKTXYYYY-Y00006	Shaft parallel plate with bearings	1 (2)**	1 (2)**	1 (2)**	1 (2)**
VRKT1YYYYY00007	Parallel linkage rod long	(1)**	0	0	0
VRKT2YYYYY00007		0	(1)**	0	0
VRKT3YYYYY00007		0	0	(1)**	0
VRKT5YYYYY00007		0	0	0	(1)**

Item reference	Item name	Quantity*			
		VRKT1	VRKT2	VRKT3	VRKT5
VRKT1YYYYY00008	Parallel linkage rod short	(1)**	0	0	0
VRKT2YYYYY00008		0	(1)**	0	0
VRKT3YYYYY00008		0	0	(1)**	0
VRKT5YYYYY00008		0	0	0	(1)**
VRKT1YYYYY00009	Lever parallel linkage	(1)**	0	0	0
VRKTXYYYY-Y00009		0	(1)**	(1)**	(1)**
VRKTXYYYY-Y00010	Bearing lever parallel linkage	1	1	1	1
<p>* When using more than one robot, increase the amount accordingly.</p> <p>** Only if there are increased requirements on the availability of the machine.</p>					

Replacement Equipment of the Lexium T Robots

Replacement Equipment

Item description and content	Representation	Item reference	To be used for
Calibration tool: <ul style="list-style-type: none"> 1x calibration tool 		VRKTXYYYYY00001	Lexium T robots
Upper arm with bearings and bolts: <ul style="list-style-type: none"> 1x upper arm complete 1x indexing bolt gearing 7x screw upper arm in case of VRKT1 11x screw upper arm in case of VRKT2, VRKT3, VRKT5 		VRKT1YYYYY00002	VRKT1...NC
		VRKT2YYYYY00002	VRKT2...NC
		VRKT3YYYYY00002	VRKT3...NC
		VRKT5YYYYY00002	VRKT5...NC
Main gearbox with fasteners and indexing bolt: <ul style="list-style-type: none"> 1x gearbox main axis 16x screw gearbox/mounting plate 4x screw motor/gearbox 1x indexing bolt gearbox 		VRKT1YYYYY00003	VRKT1...NC
		VRKTXYYYYY00003	VRKT2...NC VRKT3...NC VRKT5...NC
Lower arm with half shells and fasteners: <ul style="list-style-type: none"> 1x lower arm complete 2x half shell 8x screw half shell 8x lock washer half shell 		VRKT1YYYYY00004	VRKT1...NC
		VRKT2YYYYY00004	VRKT2...NC
		VRKT3YYYYY00004	VRKT3...NC
		VRKT5YYYYY00004	VRKT5...NC
Protector Cap for the main axes with fasteners. Set for one robot: <ul style="list-style-type: none"> 2x Protector Cap 2x supporting ring 2x O-ring for Protector Cap 24x socket head screw for Protector Cap 8x hexagon screw for Protector Cap 32x sealing washer 		VRKT1YYYYY00030	VRKT1...NC
Parallel plate with bearings and shafts: <ul style="list-style-type: none"> 1x parallel plate complete 		VRKT1YYYYY00005	VRKT1...NC
		VRKTXYYYYY00005	VRKT2...NC VRKT3...NC VRKT5...NC
Two shafts parallel plate with bearings: <ul style="list-style-type: none"> 2x shaft complete with mounted bearings 		VRKTXYYYYY00006	Lexium T robots

Item description and content	Representation	Item reference	To be used for
Parallel linkage rod long with fasteners: • 1x linkage rod complete		VRKT1YYYYY00007	VRKT1•••NC
		VRKT2YYYYY00007	VRKT2•••NC
		VRKT3YYYYY00007	VRKT3•••NC
		VRKT5YYYYY00007	VRKT5•••NC
Parallel linkage rod short with fasteners: • 1x linkage rod complete		VRKT1YYYYY00008	VRKT1•••NC
		VRKT2YYYYY00008	VRKT2•••NC
		VRKT3YYYYY00008	VRKT3•••NC
		VRKT5YYYYY00008	VRKT5•••NC
Lever parallel linkage with bearings: • 1x lever with shaft and bearings		VRKT1YYYYY00009	VRKT1•••NC
		VRKTXYYYYY00009	VRKT2•••NC VRKT3•••NC VRKT5•••NC
Bearing lever parallel linkage: • 2x shell with mounted bearings • 8x screw for shell		VRKTXYYYYY00010	Lexium T robots
Set fasteners upper arm: • 7x screw upper arm in case of VRKT1 • 11x screw upper arm in case of VRKT2, VRKT3, VRKT5		VRKT1YYYYY00011	VRKT1•••NC
		VRKTXYYYYY00011	VRKT2•••NC VRKT3•••NC VRKT5•••NC
Set of mounting shafts lower arm: • 2x mounting shaft lower arm • 1x distance ring		VRKTXYYYYY00012	Lexium T robots
PacDrive motor for main axis, MH3: • 1x motor		MH30703P02F2200	VRKT1•••NC
		MH31002P02F2200	VRKT2M0•NC VRKT3M0•NC VRKT5M0•NC

Item description and content	Representation	Item reference	To be used for
PacDrive motor for main axis, MH3: • 1x motor		MH31003P02F2200	VRKT2M1•NC VRKT3M1•NC VRKT5M1•NC
PacDrive motor for main axis, Lexium 62 ILM: • 1x motor		ILM1003P02F0000	VRKT2L••NC VRKT3L••NC VRKT5L••NC

Troubleshooting

Overview

Issue	Probable cause	Solution
Trouble with components	End of component life cycle	Note the maintenance plan, page 98.
Rattling noise	Screw joints came loose	Verify and tighten the screw joints if necessary.
Oil beads up at new gearbox	Initial oozing of the new gearbox	Clean the gearbox dry, page 103.
Grease at new ball bearing	Initial oozing of the new bearings	Clean the ball bearing dry, page 103.
Extensive position deviation after motor replacement	Robot is not calibrated	Calibrate the robot, page 118.
	Incorrect motor replacement	Mount the motor correctly, page 114.

Appendices

What's in This Part

Further Information About the Manufacturer	127
Disposal	128
Declaration of Incorporation	129

Further Information About the Manufacturer

What's in This Chapter

Contact Addresses	127
Product Training Courses.....	127

Contact Addresses

Manufacturer

Schneider Electric Automation GmbH
(Subsidiary of Schneider Electric Industries SAS FR-92500 Rueil-Malmaison)
Schneiderplatz 1
97828 Marktheidenfeld, Germany
www.se.com

Other Contacts

See the homepage for additional contact addresses:
Contact Center | Schneider Electric Global (se.com)

Product Training Courses

Product Training Courses

Schneider Electric offers a number of product training courses.
The Schneider Electric training instructors will help you take advantage of the extensive possibilities offered by the system.
See the website (www.se.com) for further information and the seminar schedule.

Disposal

Information on the Disposal of Schneider Electric Products

The robot is delivered on a recyclable ISO plastic pallet. Further packaging comprises cartons and films.

NOTE: The components consist of different materials, which cannot be reused and must be disposed of separately. Do not return the packaging to the manufacturer.

Dispose of the packaging in accordance with the relevant local, regional or national regulations.

Dispose of the packaging at the disposal sites provided for this purpose.

Dispose of robot in accordance with the applicable local, regional or national regulations.

NOTE: The gearbox units contain lubricants whose disposal may be subject to local, regional, or national regulations apart from the packaging.

Declaration of Incorporation

Declaration of Incorporation

According to EC directive 2006/42/EC on machinery (Annex II B)
 Document number / Month.Year: RBA2016001.02 / 08.2021
 - Original Language -



We: Schneider Electric Automation GmbH
 Subsidiary of Schneider Electric SE (FR 92500 Rueil-Malmaison)
 Schneiderplatz 1
 97828 Marktheidenfeld
 Germany

herewith declare, that the partly completed machinery described below:

Trademark:	Schneider Electric 
Product, Type, Function:	Robot
Models:	T-Series
Serial Number:	YYZZXXXXXX <small>(YY: Year+10, e.g. 26 = 2016; ZZ: Supplier Code: XXXXXX = cont. number)</small>

with the following references

Reference	Description
VRKT1M****00***	T1 with MH3 motor
VRKT1WM****00***	T1 without motors
VRKT2M****00***	T2 with MH3 motor
VRKT2L****00***	T2 with ILM motor
VRKT2WM****00***	T2 without motors
VRKT3M****00***	T3 with MH3 motor
VRKT3L****00***	T3 with ILM motor
VRKT3WM****00***	T3 without motors
VRKT5M****00***	T5 with MH3 motor
VRKT5L****00***	T5 with ILM motor
VRKT5WM****00***	T5 without motors

* are any letters or numbers not affecting the conformity of the product

is complying with all essential requirements of the Machinery Directive 2006/42/EC, as far as the scope of delivery allows. Additional we declare that the relevant technical documentation is compiled in accordance with part B of Annex VII.

Directive	Fulfilled Requirements	Harmonized Standard
DIRECTIVE 2006/42/EC OF THE EUROPEAN PARLIAMENT AND OF THE COUNCIL of 17 May 2006 on machinery, and amending Directive 95/16/EC	1.1.2, 1.1.3, 1.1.5, 1.3.2, 1.3.4, 1.7.2	EN ISO 10218-1:2011 Robots and robotic devices - Safety requirements for industrial robots - Part 1: Robots

We commit to transmit, in response to a reasoned request by the market surveillance authorities, relevant documents on the partly completed machinery by our documentation department. The method of transmission shall be electronic.

Name and address of the person authorised to compile the technical documentation:
Bernhard Kreitler, Schneider Electric Automation GmbH, Breslauer Straße 7, 77933 Lahr/Schwarzwald – Germany

The partly completed machinery must not be put into service until the final machinery into which it is to be incorporated has been declared in conformity with the provisions of Directive 2006/42/EC on Machinery, where appropriate, and until the EC Declaration of Conformity according to Annex II A is issued.

Issued at: Marktheidenfeld - Germany, 11th August 2021

 Schneider Electric Automation GmbH
 Schneiderplatz 1
 97828 Marktheidenfeld
 Telefon: 09391 606-0
 i.A. Michael Schweizer
 Machine Solutions - Manager Product Compliance

Index

A

ambient conditions 30
attachments 21

B

bearings
 cleaning 103
brake release 16
brake voltage 88

C

cabling 79
calibration 118
 main axes 119
 robot mechanics 118
 verification 89
characteristics 27
checking the installation 89
cleaning 103
climatic classes 30
collisions
 repair 104
commissioning 91
components 26
conditions
 installation 14
 operation 30
 storage 30, 71
 transport 30, 71
connection power 48
contact addresses 127
coordinate system
 verification 90
cycle times 50

D

declaration of incorporation 129
detail drawings 32
 lever parallel linkage 47
 lower arms 44
 main body 39
 parallel plate 45
 upper arms 43
dimensional drawing 36
dimensional drawings 32, 36
direction of rotation
 verification 90
disposal 128
domestic appliances 14

E

electrical connections 48
electrical data 32
electrical installation 79
emergency stop switch 16
emissions 21
encoder connections 48
environment
 radioactive 14

saline 14

F

feeding media 95
Flange Center Point 57
flange dimensions 93
floating systems 14
forbidden environments 14
frame 59

G

gearbox 26
 cleaning 103
 maintenance 102
 replacement 114
 technical data 69
gripper
 mounting 92
 supply 95
grounding 79

H

hazardous, explosive atmospheres 14
hazards 16
help 125
homepage 127
hot surfaces 19

I

incompatible environments 14
inspection after collisions 104
installation 12
 by crane 78
 by forklift truck 76
 conditions 14
 electrical 79
 general information 75
 verification 89
interference contours 60

L

leakiness 21
lever parallel linkage 26
 detail drawing 47
life support systems 14
load capacity diagram 57
lower arms 26
 detail drawing 44
 mounting 85
 replacement 106
lubrication
 leakiness 21
 rod system 101

M

main axes
 calibration 119
main body
 detail drawing 39
maintenance 96

gearbox	102
general information	96
motor	102
parallel plate bearings	100
parallel rods	101
upper arm bearings	99
maintenance plan	98
maintenance schedule	98
manual movement	22
mechanical data	32
misuse	13
mobile systems	14
modifications	21
monitoring	88
motor	26
maintenance	102
replacement	114
technical data	69
motor direction of rotation	
verification	90
mounting	
general information	75
gripper	92
lower arms	85
parallel rods	87
payload	92
robot	76
rotational drive unit	94
verification	89
mounting plate	26
moving without drive energy	22

N

nameplate	29
noise protection	20

O

operating conditions	14, 30
original equipment	13

P

parallel linkage	87
parallel linkage rods long	26
parallel linkage rods short	26
parallel plate	26
detail drawing	45
replacement	107
parallel plate bearings	
maintenance	100
replacement	108
parallel rods	
maintenance	101
mounting	87
replacement	110
parametrization	84
partially completed machinery	129
partly completed machinery	12
payload	
mounting	92
performance data	50
portable systems	14
problems and solutions	125
product overview	25
proper use	12
protective devices	88

protective measures	12
---------------------	----

Q

qualification of personnel	15
qualified person	15

R

radioactive environment	14
remaining risks	16
repair	96
repair after collisions	104
replacement	105
gearbox	114
lower arms	106
motor	114
parallel plate	107
parallel plate bearings	108
parallel rods	110
upper arms	111
replacement equipment	
inventory	120
residual risks	16
robot	
cabling	79
characteristics	27
grounding	79
mounting	76
packaging	73
preparing for installation	74
rotational drive unit	
mounting	94
run-on path	61

S

saline environment	14
SchneiderElectricRobotic library	84
seminars	127
Sercos addresses	84
service addresses	127
service schedule	98
servicing	97
software limits	88
solutions	125
spare parts	120
start-up	91
stop function categories	61
stopping path	61
stopping time	61
storage conditions	30, 71
system architecture	24
system setup	25
systems	
floating	14
life support	14
mobile	14
portable	14

T

technical data	
robot	32
third-party devices	13
tool center point	59
training	15

training courses.....	127
transport conditions	30, 71
troubleshooting	125
type plate	
description.....	29
position	29

U

underground	14
unpacking	72
upper arm bearings	
maintenance.....	99
upper arms	26
detail drawing	43
replacement	111

V

verification	
calibration.....	89
coordinate system.....	90
installation	89
motor direction of rotation	90
mounting	89

W

wiring	79
--------------	----

Schneider Electric
35 rue Joseph Monier
92500 Rueil Malmaison
France

www.se.com

As standards, specifications, and design change from time to time, please ask for confirmation of the information given in this publication.

© 2025 Schneider Electric. All rights reserved.

EIO0000002280.05