

Modicon MC80 Programmable Logic Controller (PLC)

User Manual



06/2020



The information provided in this documentation contains general descriptions and/or technical characteristics of the performance of the products contained herein. This documentation is not intended as a substitute for and is not to be used for determining suitability or reliability of these products for specific user applications. It is the duty of any such user or integrator to perform the appropriate and complete risk analysis, evaluation and testing of the products with respect to the relevant specific application or use thereof. Neither Schneider Electric nor any of its affiliates or subsidiaries shall be responsible or liable for misuse of the information contained herein. If you have any suggestions for improvements or amendments or have found errors in this publication, please notify us.

No part of this document may be reproduced in any form or by any means, electronic or mechanical, including photocopying, without express written permission of Schneider Electric.

All pertinent state, regional, and local safety regulations must be observed when installing and using this product. For reasons of safety and to help ensure compliance with documented system data, only the manufacturer should perform repairs to components.

When devices are used for applications with technical safety requirements, the relevant instructions must be followed.

Failure to observe this information can result in injury or equipment damage.

© 2020 Schneider Electric. All rights reserved.

Table of Contents



	Safety Information	5
	About the Book	7
Part I	Modicon MC80 PLC	9
Chapter 1	Introduction to Modicon MC80 PLC	11
	Modicon MC80 PLC	11
Part II	MC80 Hardware Implementation	13
Chapter 2	Introduction to Modicon MC80 PLC Processor	15
	General Introduction	16
	General Characteristics of the Processor	17
	Execution of Tasks	19
Chapter 3	Installation of Modicon MC80 PLC	21
	Dimensions and Mounting	22
	Installation Rules	24
Chapter 4	Power Supply	25
	Power Supply	25
Chapter 5	Discrete Input and Output Function (8 Input 8 Output)	29
	Discrete Input and Output Function (8 Input 8 Output)	30
	Connecting Discrete I/O Function (8 Input 8 Output)	33
	Fitting a 20-Pin Terminal Block	35
	20-Pin Terminal Block Modules	36
	Discrete I/O Function (8 Input 8 Output) and Channel Status Display	38
Chapter 6	Discrete Inputs and Outputs (8 Input 12 Output)	39
	Discrete Input and Output Function (8 Input 12 Output)	40
	Connecting Discrete I/O Function	43
	Fitting a 28-Pin Terminal Block	45
	28-Pin Terminal Block Modules	46
	Discrete I/O Function (8 Input 12 Output) and Channel Status Display	48
Chapter 7	Analog Input Function	49
	Analog Input Function Overview	50
	Analog Input Functional Description	51
Chapter 8	High Speed Counting Input and Output Function	57
	High Speed Counting Input and Output Function	58
	Display and Diagnostics of the High Speed Counting Function	60
	HSC Function Wiring	61
	Fitting a 28-Pin Terminal Block	63
	28-Pin Terminal Block Modules	64
Chapter 9	Communication	67
	Communication	68
	Serial Link	69
	Ethernet Link	71
	CANopen Link	74
	USB Link	76
Chapter 10	Grounding of PLC	77
	Grounding of PLC	77
Chapter 11	Operating Standards and Conditions	81
	Standards and Certifications	82
	Operating Conditions	83

Part III	MC80 Software Implementation	85
Chapter 12	Configuration of MC80	87
	Configuration of Modicon MC80 Processors	88
	Connecting to MC80	91
	IO Configuration	92
	Configuring the Serial Port of the CPU	111
	Modbus Serial communication	114
	Character Mode Communication	119
	Configuring the Ethernet Port of the CPU	123
	CANopen Configuration	132
	System Bits and Words	141
Chapter 13	MC80 Firmware Upgrade	151
	Firmware Upgrade	151



Important Information

NOTICE

Read these instructions carefully, and look at the equipment to become familiar with the device before trying to install, operate, or maintain it. The following special messages may appear throughout this documentation or on the equipment to warn of potential hazards or to call attention to information that clarifies or simplifies a procedure.



The addition of this symbol to a “Danger” or “Warning” safety label indicates that an electrical hazard exists which will result in personal injury if the instructions are not followed.



This is the safety alert symbol. It is used to alert you to potential personal injury hazards. Obey all safety messages that follow this symbol to avoid possible injury or death.

DANGER

DANGER indicates a hazardous situation which, if not avoided, **will result in** death or serious injury.

WARNING

WARNING indicates a hazardous situation which, if not avoided, **could result in** death or serious injury.

CAUTION

CAUTION indicates a hazardous situation which, if not avoided, **could result in** minor or moderate injury.

NOTICE

NOTICE is used to address practices not related to physical injury.

PLEASE NOTE

Electrical equipment should be installed, operated, serviced, and maintained only by qualified personnel. No responsibility is assumed by Schneider Electric for any consequences arising out of the use of this material.

A qualified person is one who has skills and knowledge related to the construction and operation of electrical equipment and its installation, and has received safety training to recognize and avoid the hazards involved.

About the Book



At a Glance

Document Scope

This manual describes the installation and configuration of the Modicon MC80 PLC's hardware, software, and main accessories.

Validity Note

This documentation is valid for Unity Pro 8.1 and later versions.

Product Related Information

 WARNING
UNINTENDED EQUIPMENT OPERATION The application of this product requires expertise in the design and programming of control systems. Only persons with such expertise should be allowed to program, install, alter, and apply this product. Follow all local and national safety codes and standards. Failure to follow these instructions can result in death, serious injury, or equipment damage.

Part I

Modicon MC80 PLC

Chapter 1

Introduction to Modicon MC80 PLC

Modicon MC80 PLC

General Description

Modicon MC80 PLC is an automated platform processor which is compact with discrete I/O functions, analog input functions, counting functions, and communication functions.

Illustration

The following figure shows the parts of Modicon MC80 PLC:

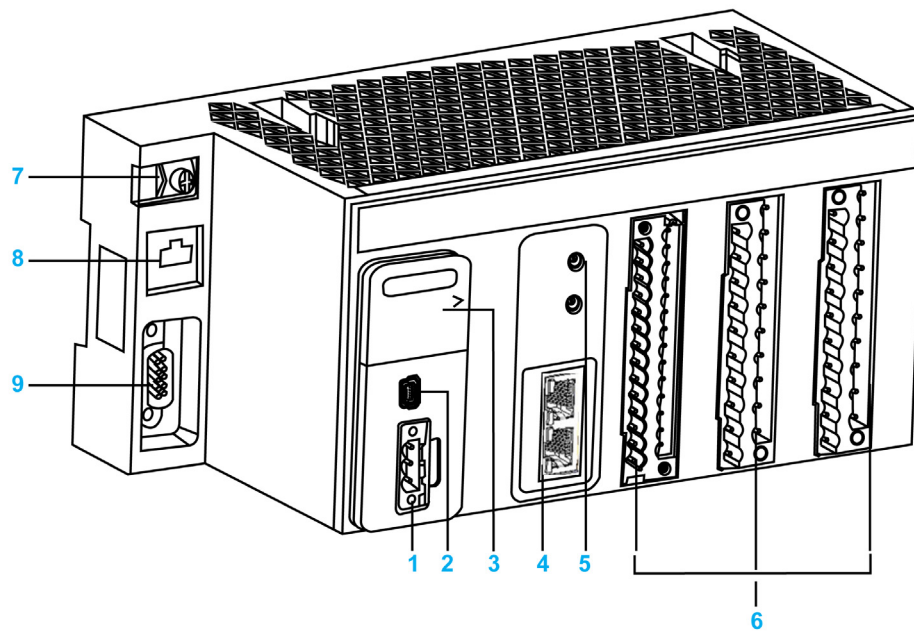

- 1 Power supply input
- 2 USB port
- 3 Reset button
- 4 Ethernet link
- 5 Rotary switch for IP addressing
- 6 I/O functions
- 7 Grounding screw
- 8 Serial link
- 9 CANopen link

The following table provides the details of the BMK C80 processors:

Processor	Description
BMK C80 20310	Controller, 8 DI, 8 DO, and 2 HSC
BMK C80 20301	Controller, 8 DI, 12 DO, and 4 AI
BMK C80 30311	Controller, 8 DI, 12 DO, 2 HSC, and 4 AI

The MC80 PLC is compatible with the terminal blocks BMX FTB 20x0 and BMX FTB 28x0 which needs to be ordered separately.

Part II

MC80 Hardware Implementation

What Is in This Part?

This part contains the following chapters:

Chapter	Chapter Name	Page
2	Introduction to Modicon MC80 PLC Processor	15
3	Installation of Modicon MC80 PLC	21
4	Power Supply	25
5	Discrete Input and Output Function (8 Input 8 Output)	29
6	Discrete Inputs and Outputs (8 Input 12 Output)	39
7	Analog Input Function	49
8	High Speed Counting Input and Output Function	57
9	Communication	67
10	Grounding of PLC	77
11	Operating Standards and Conditions	81

Chapter 2

Introduction to Modicon MC80 PLC Processor

What Is in This Chapter?

This chapter contains the following topics:

Topic	Page
General Introduction	16
General Characteristics of the Processor	17
Execution of Tasks	19

General Introduction

Description

Modicon MC80 processor is an automated platform processor which manages the entire PLC station made up of discrete I/O functions, analog input functions, counting functions, and communication functions.

MC80 PLCs are available in these variants

- BMK C80 20310
- BMK C80 20301
- BMK C80 30311

Features

The main features of Modicon MC80 processor are:

- CANopen master limited to 16 devices
- Dual Ethernet port with embedded switch
- Serial line RS485/RS232
- USB port
- Discrete Inputs
- Discrete Outputs
- High Speed Counter function
- Analog Inputs function

NOTE: For details, see the input/output combination (*see page 17*).

General Characteristics of the Processor

Description

This matrix provides the details for CPU reference and Input/Output functions:

	BMK C80 20310	BMK C80 20301	BMK C80 30311
Number of Discrete Inputs	8 standard + 12 from HSC channels	8 standard	8 standard + 12 from HSC channels
Number of Discrete Outputs	8 standard + 4 from HSC channels	12 standard (2.0 A)	12 standard (2.0 A) + 4 from HSC channels
Number of Analog Inputs	-	4	4
Number of High Speed Counter	2 channels (6 DI and 2 DO per channel)	-	2 channels (6 DI and 2 DO per channel)
Modbus connection	X	X	X
Integrated CANopen master connection	X	X	X
Integrated Ethernet connection	X	X	X
X: Accessible function -: Inaccessible function			

BMK C80 ***** Processor Characteristics

The following table lists the characteristics of the BMK C80 ***** processors:

Processor			BMK C80 *****
Description			RS232/RS485, USB, Serial port, Ethernet, CANopen
Retention memory capacity			128 kB
User application memory			3,584 kB
RTC	Accuracy	Powered	16 minutes per year @25 °C (without calibration)
		Non-powered	12 seconds per 72 hours @25 °C (retention duration)
	Retention time		72 hours
	Battery		Without
USB physical spec.	Type	USB2.0 Device	
	Speed mode	Full speed mode (12 Mbps)	
Serial port			RJ45, RS232/RS485. 300...19,200 bps Modbus slave, Modbus master RTU/ASCII, Character mode.
Ethernet port			2
CANopen			Up to 16 devices
LED display			PWR (green) RUN (green) ERR (red) SER COM (yellow) IO (red) CAN RUN (green) CAN ERR (red) ETH STS (green)
Real-time Clock			Date and time with 1 ms resolution (resolution is 1 sec when power is off).

The following figure shows the LED indicator:

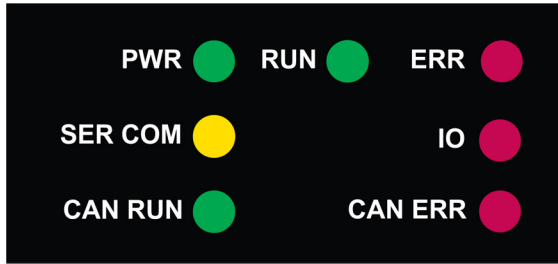

The following table lists the definition of the LED indicators:

Label	Color	Description
PWR	Green	Indicates the power supply status
RUN	Green	Indicates the module operation status
ERR	Red	Indicates the detected errors of the module
IO	Red	Indicates the detected error on IO ports

The following table shows LED combination for CPU state (S=solid, 0=OFF, B=blinking):

RUN	ERR	IO	CPU State		
B	B	B	The CPU is booting or executing power on self tests or detects an invalid or missing OS.		
0	B	0	The CPU is not configured		
B	0/B	0/S	The CPU is in stop state.		
			ERR LED	blinking	if non fatal error is detected
				off	if the error is not detected.
			IO LED	solid	if there is an IO error.
			off	if there is no IO error.	
S	0/B	0/S	The CPU is in RUN mode.		
0	S	S	The Fatal error is detected and the CPU has permanent reset, no communication is available.		
B	S	0	Firmware download is in progress		

A LED can have three states: solid, off, or blinking at 2 Hz (time on = time off = 250 ms). When the product is powered, there is at least one LED in Solid or Blinking state, irrespective of the CPU state.

Execution of Tasks

Description

The MC80 processor supports MAST task with periodic and cyclic modes.

Master Task

The master task represents the application program's main task. You can choose from the following MAST task execution modes:

- Cyclical (default setup): execution cycles are performed in sequence, one after the other.
- Periodical: a new cycle is started periodically, according to a user-defined time period (1...255 ms) with 1 ms increment.

If the execution time is longer than the period configured by you, then the bit %S19 is set to 1 and a new cycle is launched.

Both MAST task cycle modes are controlled by a watchdog.

The watchdog is triggered if the MAST task execution time is longer than the watchdog value in the configuration, and causes a software error. The application then goes into HALT status, and the bit %S11 is set to 1 (you must reset it to 0).

The watchdog value (%SW11) may be configured between 10 ms and 1,500 ms (default value: 250 ms).

NOTE: Configuring the watchdog to a value that is less than the period is not allowed.

The system tasks with higher priority than MAST will have an impact of MAST task duration.

The following table shows how the main services are assigned to a priority (highest priority impacts all services with lowest priority):

Highest priority	Interrupts: system timer, CAN, ETH, USB, serial ports
	Exception handler task ⁽¹⁾
	RSTP
	Ethernet frame process
	PLC operating mode transition management (run, stop, new download) ⁽²⁾
	CANopen process
	MAST task
	PLC low priority task: online change, application backup to flash
Lowest priority	Other Ethernet services: DHCP, SNMP
⁽¹⁾ Exception lead to error state and permanent reset of the function	
⁽²⁾ Task activated only on PLC state change	

Chapter 3

Installation of Modicon MC80 PLC

What Is in This Chapter?

This chapter contains the following topics:

Topic	Page
Dimensions and Mounting	22
Installation Rules	24

Dimensions and Mounting

Dimensions of MC80 PLC

The following figure shows the overall dimensions of the MC80 PLC:

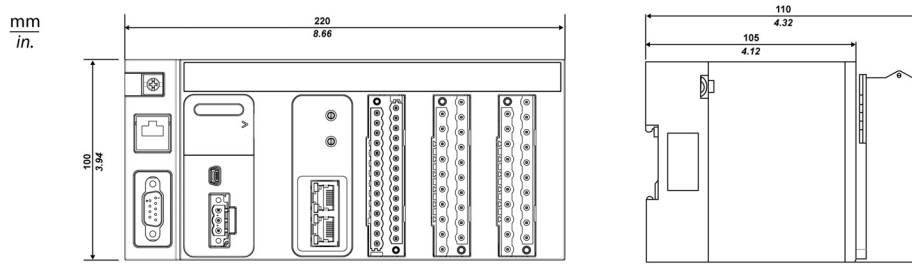

NOTE: The terminal block should be ordered separately. This equipment is "enclosed". It can be installed without any specific protection in areas with restricted access and low pollution levels (not exceeding 2). In other environments, it is recommended to follow rules of installation in a cabinet. Refer to Control Expert documentation, *Chapter "General Safety Instructions for the user": 6.2 Environmental conditions.*

For compliance to UL (Underwriters Laboratories) requirements, the product is an "open equipment".

For North America systems, the installation and operation of this equipment in an end fire enclosure appropriately rated for its intended environment.

Mounting and Fastening the MC80 PLC

MC80 PLC can be mounted on:

- DIN rails of 35 mm (1.38 in.) wide
- Panels

Mounting on DIN Rails

The following are the two types of DIN rails used for mounting MC80 PLC:

- Mounting on a 35 mm (1.38 in.) wide and 15 mm (0.59 in.) deep DIN rails
- Mounting on a 35 mm (1.38 in.) wide and 7.5 mm (0.295 in.) deep DIN rails

The following table describes the procedure for mounting the MC80 PLC on a DIN rail:

Step	Description	Illustration
1	Position the PLC on the DIN rail as indicated in the figure.	The following figure shows the mounting on a DIN rail:
2	Press down on the MC80 product (1) in order to compress the springs, then tip the product backwards against the rail (2).	
3	Release the MC80 product to lock it.	

To remove the MC80 product, perform the mounting procedure in reverse.

Press down on the product (1) in order to compress the springs, then tip the product forwards to disengage it from the rail (2).

NOTE: To make sure that the PLCs continue to operate correctly when there is severe electromagnetic interference, you must mount the modules on properly grounded metallic mountings.

Mounting on Panels

The figure below shows the screw-hole layout for mounting the MC80 PLC on a panel (dimensions in mm/inch):

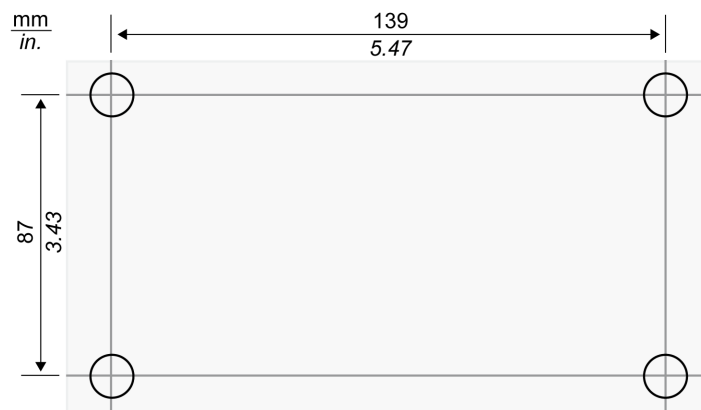

The diameter of the fastening holes must allow the use of M4 screws.

NOTE: Tighten the screw to help ensure the contact between the BKP and the panel.

Installation Rules

Introduction

When assembling MC80 module, you must comply with certain installation rules.

Module Installation Rules: Description

⚠ WARNING
UNEXPECTED EQUIPMENT OPERATION
Install MC80 lengthways and horizontally to facilitate ventilation.
MC80 is cooled by natural convection. Other positions may cause overheating and unexpected equipment operation.
Failure to follow these instructions can result in death, serious injury, or equipment damage.

If MC80 is installed in a cabinet, you are advised to comply with the following measures:

- leave a minimum space of 80 mm (3.15 inch) above and 60 mm (2.36 inch) below the modules to facilitate air circulation
- leave a minimum space of 60 mm (2.36 inch) between the modules and the wiring ducts to facilitate air circulation

The minimum depth of the cabinet should be:

- 150 mm (5.91 inch) if the rack is fastened to a plate
- 160 mm (6.30 inch) if the rack is mounted on a 15 mm (0.59 inch) deep DIN rail

⚠ WARNING
INADEQUATE THERMAL CLEARANCE
Maintain proper thermal distances when installing the MC80 to prevent overheating and unexpected equipment operation.
Failure to follow these instructions can result in death, serious injury, or equipment damage.

The following figure shows the rules of installation in a cabinet:

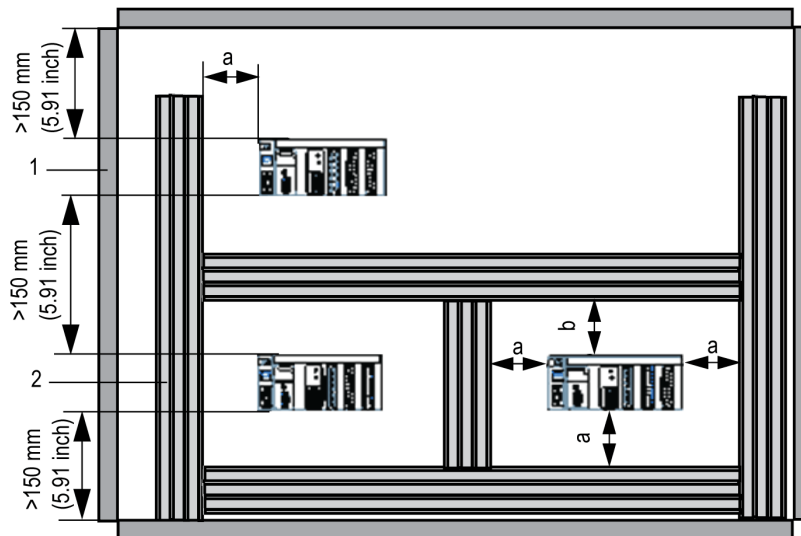

- a** Greater than or equal to 60 mm (2.36 inch)
- b** Greater than or equal to 80 mm (3.15 inch)
- 1** Installation or casing
- 2** Wiring duct or tray

Chapter 4

Power Supply

Power Supply

Description

A galvanic isolated 24 Vdc power supply on MC80 PLC supplies the whole module.

A LED function is mounted on the power supply function to indicate the module and communication status. A reset button is also placed on the power supply function.

The following table contains the main physical features of power supply:

Item	Specification
Input type	DC
Nominal Input Voltage	24 Vdc
Input Voltage range	20.4...28.8 Vdc
Current	700 mA max.
Isolation level	1,500 Vdc (@0...2,000m)

Representation

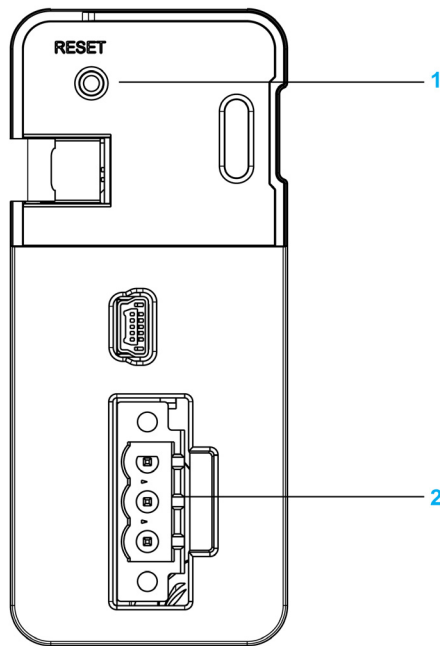

- 1 Reset button
- 2 24 V Power socket

The following figure shows the power connector:

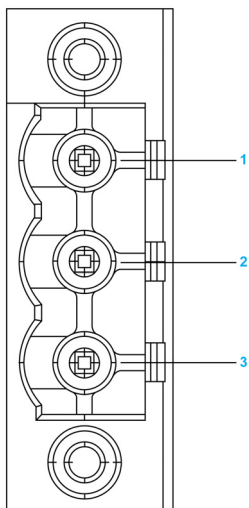

The below table lists the pin assignment of the connector:

Pin No.	Signal Name	Description
1	24 V	DC 24 V input
2	0 V	
3	FG	Functional Ground

The following figure shows the insertion of 3-pin terminal block in the power supply:

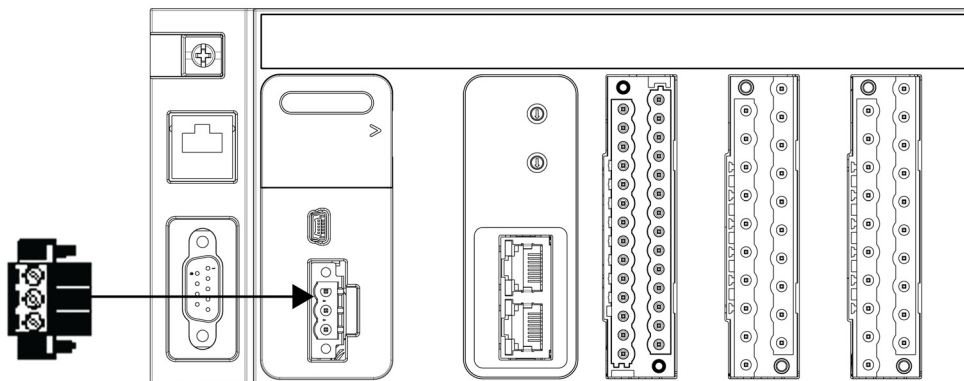

DC Power Supply Requirements

The MC80 PLCs require power supplies with a nominal voltage of 24 Vdc.

The 24 Vdc power supplies must be rated Protective Extra Low Voltage (PELV) according to IEC 61140.

These power supplies are isolated between the electrical input and output circuits of the power supply.

⚠ WARNING

POTENTIAL OF OVERHEATING AND FIRE

- Do not connect the equipment directly to line voltage.
- Use only isolating PELV power supplies to supply power to the equipment.

Failure to follow these instructions can result in death, serious injury, or equipment damage.

Rules of Wiring

The below table shows the description of the terminal block:

Description	Terminal Block
Number of wires per point	1 wire per point
Wire gauge	AWG 18-16, 0.8-1.3 mm ²
Maximum screw tightening torque	Depends on connector supplied (*)
Cable Ends and Contacts	The terminal block can accommodate: <ul style="list-style-type: none"> • Bare wires • Wires with DZ5-CE type cable ends: 
Temperature range of wires	Minimum 105 °C
(*) For connector Dinkle 0.50 N•m (4.5 lb.ft) For connector Phoenix Contact 0.56 N•m (5.0 lb.ft) For connector FCI 0.330 N•m (3.0 lb.ft) For connector Weidmuller 0.50 N•m (4.5 lb.ft)	

Reset Button

The Reset button can be used to activate a cold start whenever necessary. The pressing time should be a minimum of 20 ms.

Chapter 5

Discrete Input and Output Function (8 Input 8 Output)

What Is in This Chapter?

This chapter contains the following topics:

Topic	Page
Discrete Input and Output Function (8 Input 8 Output)	30
Connecting Discrete I/O Function (8 Input 8 Output)	33
Fitting a 20-Pin Terminal Block	35
20-Pin Terminal Block Modules	36
Discrete I/O Function (8 Input 8 Output) and Channel Status Display	38

Discrete Input and Output Function (8 Input 8 Output)

Description

The Discrete Input and Output (Discrete I/O) is a 24 Vdc function connected using a 20-pin terminal block (BMXFTB20x0). It is a positive logic function where the eight input channels receive current from the sensors (sink) and the eight output channels provide current to the pre-actuators (source).

This discrete I/O function is available on the BMK C80 20310 PLC.

General Input Characteristics

These are the general input characteristics of the Discrete I/O function:

Characteristic	Description	Value	
Nominal input values	Voltage	24 Vdc	
	Current	5 mA	
Threshold input values	At 1	Voltage	≥ 11 V
		Current	> 2 mA for $U \geq 11$ V
	At 0	Voltage	≤ 5 V
		Current	≤ 1.5 mA
	Sensor supply (including ripple)		19...30 V
Input impedance	At nominal U	4.8 k Ω	
Response time	Disappearance/appearance	4 ms < T < 5 ms	
IEC 61131-2- Edition 2 (2007)		Type 3	
Reverse polarity	Input	Provides an external fuse to the sensor 24 V.	
2-wire/3-wire proximity sensor compatibility		IEC 947-5-2	
Dielectric strength	Between PLC bus and field sides	1,500 Vdc for 1 minute	
	Between input and output groups	500 Vdc	
Resistance of insulation		> 10 M Ω (at 500 Vdc)	
Type of input		Current sink	
Paralleling of inputs		No	
Sensor voltage monitoring threshold		No	
Sensor power supply (8 inputs on)	Typical	46 mA	
	Maximum	51 mA	
24 V sensor power supply (excluding load current)	Typical	26 mA	
	Maximum	35 mA	
24 V sensor power supply consumption@25 °C (all channels OFF)		10.11 mA	
24 V sensor power supply consumption@25 °C (all channels ON)		46.11 mA	

WARNING

LOSS OF INPUT FUNCTION

Do not implement the voltage over maximum limit value.

Failure to follow these instructions can result in death, serious injury, or equipment damage.

Input Fuses

Fuse	Value
Internal	None
External	1 fast blow fuse of 0.5 A for the input group

⚠ CAUTION**LOSS OF INPUT FUNCTION**

Install the correct rating and type of fuse.

Failure to follow these instructions can result in injury or equipment damage.

General Output Characteristics

The following table shows the general output characteristics of the Discrete I/O function:

Characteristic	Description	Value
Nominal values	Voltage	24 Vdc
	Current	0.5 A
Limited values	Maximum voltage	19...30 V
	Maximum current for overflow protection/Channel (single channel shutdown)	0.625 A
Power of tungsten filament lamp	Maximum	6 W
Leakage current	At 0	<0.5 mA
Voltage drop	At 1	<1.2 V
Load impedance	Minimum	48 Ω
Response time ⁽¹⁾		<1.2 ms
Frequency of switching to inductive load		0.5/LI ² Hz
Paralleling of outputs		Yes (maximum of 2 channels and total 1 A) ⁽²⁾ .
Built-in protection	Against inversions	Yes, by inverted diode ⁽³⁾ .
	Against short circuits and overloads	Yes, by internal current limiter at 0.7 A<I<1.7 A (typical 1 A) after internal over-temperature is detected
Pre-actuator voltage: monitoring threshold	OK	>19 Vdc (max.)
	Fault	<14 Vdc (typ.)
Pre-actuator voltage: monitoring response time	On appearance	2 ms<T<4 ms
	On disappearance	9 ms<T<11 ms
24 V pre-actuator consumption (excluding load current)	Typical	26 mA
	Maximum	35 mA
Dielectric strength	Between PLC bus and field sides	1,500 Vdc for 1 minute
Resistance of insulation		>10 MΩ (at 500 Vdc)

⁽¹⁾ All outputs are equipped with fast demagnetization circuits for electromagnets. Electromagnet discharge time < L/R.

⁽²⁾ Users have to control the two parallel channels simultaneously to avoid overload on one channel. Users can only parallel two channels both from first 4 channels (Channel 16 to 19), or parallel two channels both from the last 4 channels (Channel 20 to 23). Paralleling one channel from first 4 channels (Channel 16 to 19) with another channel from the last 4 channels (Channel 20 to 23) is forbidden.

⁽³⁾ Provide a 2 A fuse to the +24 V pre-actuator supply.

⚠ WARNING**LOSS OF OUTPUT FUNCTION**

Do not implement the voltage over maximum limit value.

Failure to follow these instructions can result in death, serious injury, or equipment damage.

Output Fuses

Fuse	Value
Internal	None
External	1 fast blow fuse of 6.3 A for the output group

 CAUTION
--

LOSS OF OUTPUT FUNCTION

Install the correct rating and type of fuse.
--

Failure to follow these instructions can result in injury or equipment damage.

Connecting Discrete I/O Function (8 Input 8 Output)

Description

The Discrete I/O (8 Input 8 Output) function is fitted with a removable 20-pin terminal block (BMXFTB20x0) for the connection of eight input channels and eight output channels.

Input Circuit Diagram

The following diagram shows the circuit of a direct current input (positive logic).

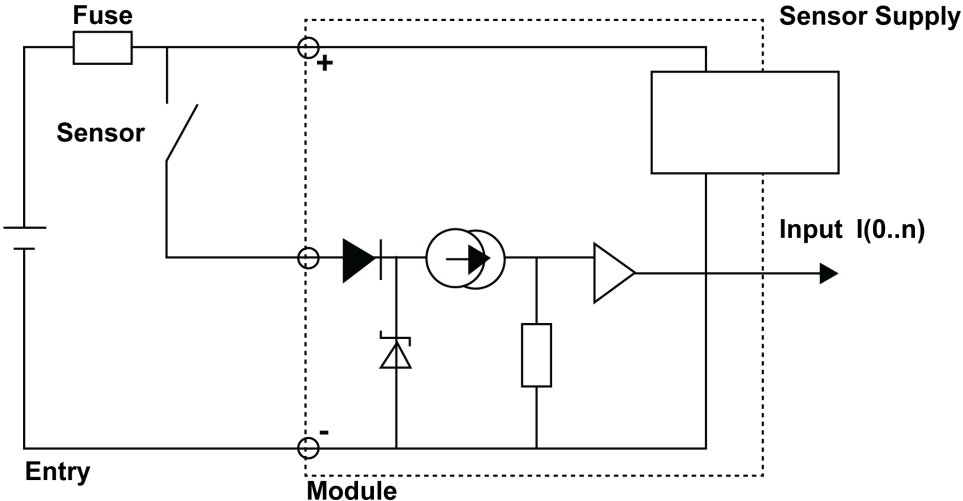

Output Circuit Diagram

The following diagram shows the circuit of a direct current output (positive logic).

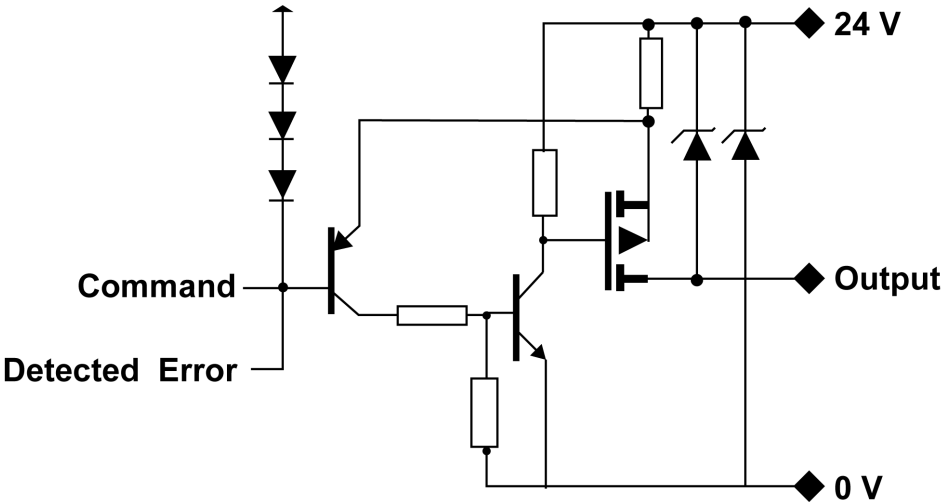

Discrete I/O Connection

The following diagram shows the connection of the function to the sensors and pre-actuators.

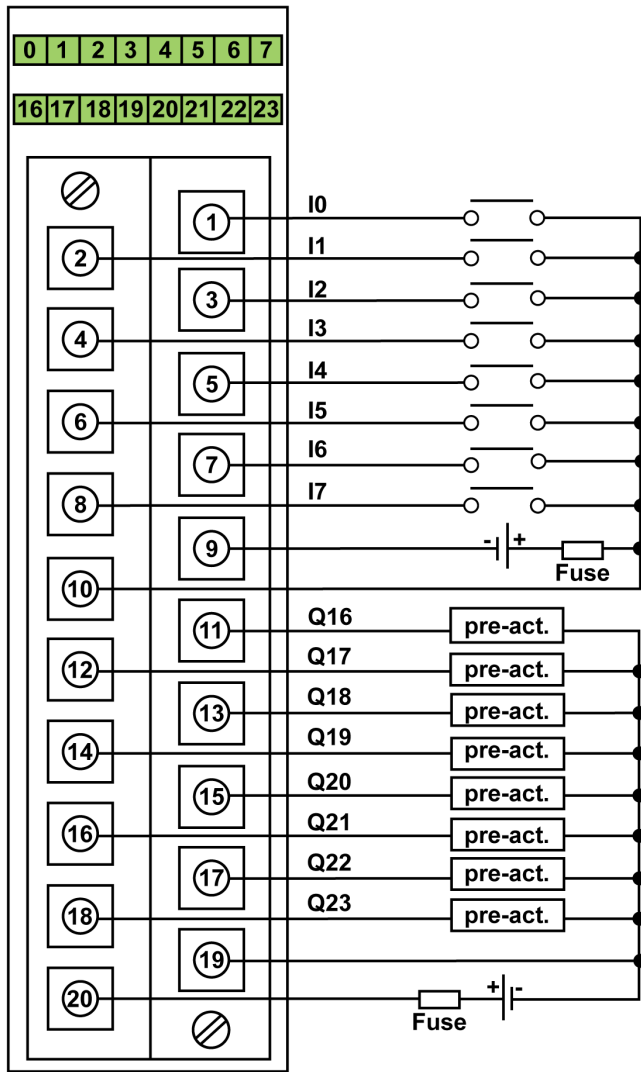

power supply: 24 Vdc
input fuse: fast blow fuse of 0.5 A
output fuse: fast blow fuse of 6.3 A
pre-act: pre-actuator

The following table lists the suitable terminal block references for Discrete Input & Output function:

I/O Function	Reference Number
Discrete Input & Output function	BMX FTB 2000
	BMX FTB 2010
	BMX FTB 2020

NOTE: Make sure to follow the correct connection to the sensors and pre-actuators.

Fitting a 20-Pin Terminal Block

Installing the 20-Pin Terminal Block

The following table shows the assembling of the 20-pin terminal block onto I/O functions tightening torque 0.4 N•m (0.30 lb-ft):

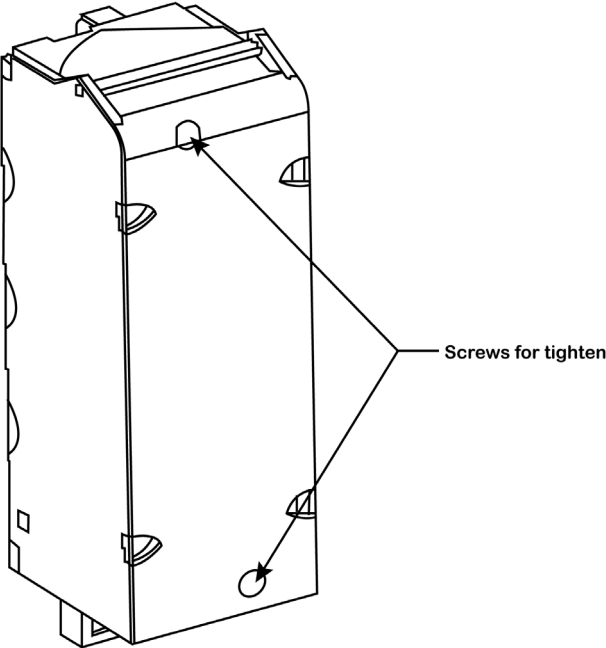

NOTE: If the screws are not tightened, the terminal block may not be properly fixed to the module.

20-Pin Terminal Block Modules

At a Glance

The Discrete I/O (8 Input 8 Output) and Analog Input functions are supplemented by a 20-pin terminal block.

There are three types of 20-pin terminal blocks:

- BMX FTB 2010 screw clamp terminal blocks
- BMX FTB 2000 caged terminal blocks
- BMX FTB 2020 spring terminal blocks

Cable Ends and Contacts

Each terminal block can accommodate:

- Bare wires
- Wires with DZ5-CE type cable ends:



Description of the 20-Pin Terminal Blocks

The table below shows the description of the 3 types of 20-pin terminal blocks:

		Screw clamp terminal blocks	Caged terminal blocks	Spring terminal blocks
Illustration				
Number of wires accommodated		2	1	1
Number of wire gauges accommodated	minimum	AWG 24 (0.34 mm ²)		
	maximum	AWG 16 (1.5 mm ²)		
Wiring constraints		<p>Screw clamps have slots that accept:</p> <ul style="list-style-type: none"> • flat-tipped screwdrivers with a diameter of 5 mm, • posidriv n° 1 cross-tipped screwdrivers. <p>Screw clamp terminal blocks have captive screws. On the supplied blocks, these screws are not tightened.</p>	<p>Caged terminal blocks have slots that accept:</p> <ul style="list-style-type: none"> • flat-tipped screwdrivers with a diameter of 3 mm, • posidriv n° 1 cross-tipped screwdrivers. <p>Caged terminal blocks have captive screws. On the supplied blocks, these screws are not tightened.</p>	<p>The wires are connected by pressing on the button located next to each pin. To press on the button, you have to use a flat-tipped screwdriver with a maximum diameter of 3 mm.</p>
Maximum screw tightening torque		0.5 N•m (0.37 lb-ft).	0.5 N•m (0.37 lb-ft).	-
Temperature range of wire		Minimum 105 °C		

⚠ DANGER

ELECTRICAL SHOCK

The terminal block must be connected or disconnected with sensor and pre-actuator voltage switched off.

Failure to follow these instructions will result in death or serious injury.

Labeling of 20-Pin Terminal Blocks

Labels for the 20-pin terminal blocks are supplied with the module. They are to be inserted in the terminal block cover by the customer.

Each label has two sides:

- One side that is visible from the outside when the cover is closed. This side features the commercial product references, an abbreviated description of the module, as well as a blank section for customer labeling.
- One side that is visible from the inside when the cover is open. This side shows the terminal block connection diagram.

Discrete I/O Function (8 Input 8 Output) and Channel Status Display

Description

The Discrete I/O functions are equipped with a display block featuring LEDs that displays the functions channel status and the overall function status.

Representation

The below figure shows the LED indicator of the Discrete I/O function:

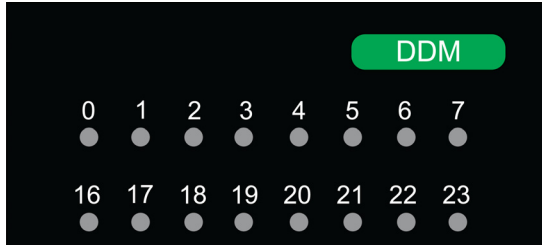

NOTE: The mixed input/output function has two groups of eight channels. The input group is represented by channels 0...7 and the output group is represented by channels 16...23.

The following table helps you to perform diagnostics of the discrete I/O function status according to the channel LEDs:

Status		Meaning
0...7	16...23	
ON	-	Voltage is present on the input channel
-	ON	Voltage is present on the output channel
-	BLK	Actuator supply fails
-	FLK	Output channel is overload/short-circuit
Legends		
-		Not applicable
ON		LED is steady on
BLK (Blinking)		The LED is turned on for 200 ms, then turned off for 200 ms
FLK (Flickering)		The LED is turned on for 50 ms, then turned off for 50 ms

NOTE:

- Display of internal or external events is effective once the module is configured.
- When an event is detected, the channel status is recorded until the cause of the event is cleared.
- The output channel is closed by default.

⚠ WARNING

CHANNEL LED INFORMATION NOT MATCHING SENSORS VALUE

After a sensor power outage:

- Do not take into account the input LEDs information (they show the last recorded value of the sensors, not their real value).
- Check the real positions on the sensors.

Failure to follow these instructions can result in death, serious injury, or equipment damage.

Chapter 6

Discrete Inputs and Outputs (8 Input 12 Output)

What Is in This Chapter?

This chapter contains the following topics:

Topic	Page
Discrete Input and Output Function (8 Input 12 Output)	40
Connecting Discrete I/O Function	43
Fitting a 28-Pin Terminal Block	45
28-Pin Terminal Block Modules	46
Discrete I/O Function (8 Input 12 Output) and Channel Status Display	48

Discrete Input and Output Function (8 Input 12 Output)

Description

The Discrete Input and Output (Discrete I/O) is a 24 Vdc function connected using a 28-pin terminal block (BMXFTB28x0). It is a positive logic function where the 8 input channels receive current from the sensors (sink) and the 12 output channels provide current to the pre-actuators (source).

The Discrete I/O function is available on the following PLC:

- BMK C80 20301
- BMK C80 30311

General Input Characteristics

The following table shows the general input characteristics of the Discrete I/O function:

Characteristic	Description	Value	
Nominal input values	Voltage	24 Vdc	
	Current	2.4 mA	
Threshold input values	At 1	Voltage	≥ 11 V
		Current	> 2 mA for $U \geq 11$ V
	At 0	Voltage	≤ 5 V
		Current	≤ 1.5 mA
	Sensor supply (including ripple)		19...30 V
Input impedance	At nominal U	10 k Ω	
Sensor supply monitoring threshold	OK	> 17 V(Typical)	
	Fault	< 8 V(Typical)	
Response time	Disappearance/appearance	4 ms $< T < 5$ ms	
IEC 61131-2- Edition 2 (2007)		Type 3	
Reverse polarity	Input	Provides an external fuse to the sensor 24 V.	
2-wire/3-wire proximity sensor compatibility		IEC 947-5-2	
Dielectric strength	Between PLC bus and field sides	1,500 Vdc for 1 minute	
	Between input and output groups	500 Vdc	
Resistance of insulation		> 10 M Ω (at 500 Vdc)	
Type of input		Current sink	
Paralleling of inputs		No	
Sensor voltage monitoring threshold		No	
Sensor power supply (8 inputs on)	Typical	30 mA	
	Maximum	35 mA	
24 V sensor power supply (excluding load current)	Typical	8 mA	
	Maximum	10 mA	
24 V sensor power supply consumption@25 °C (all channels OFF)		8 mA	
24 V sensor power supply consumption@25 °C (all channels ON)		30 mA	

WARNING

LOSS OF INPUT FUNCTION

Do not implement the voltage over maximum limit value.

Failure to follow these instructions can result in death, serious injury, or equipment damage.

Input Fuses

Fuse	Value
Internal	None
External	1 fast blow fuse of 0.5 A for the input group

CAUTION

LOSS OF INPUT FUNCTION

Install the correct rating and type of fuse.

Failure to follow these instructions can result in injury or equipment damage.

General Output Characteristics

The following table shows the general output characteristics of the Discrete I/O function:

Characteristic	Description	Value
Nominal values	Voltage	24 Vdc
	Current	2 A
Limited values	Maximum voltage	19...30 V
	Current/Channel	2.5 (1)
	Current/12 channels	10 A
Power of tungsten filament lamp	Maximum	60 W
Leakage current	At 0	<0.5 mA
Voltage drop	At 1	<1.2 V
Load impedance	Minimum	12 Ω
Response time ⁽²⁾		<1.2 ms
Frequency of switching to inductive load		0.5/LI ² Hz
Paralleling of outputs		Yes (maximum of 2 channels and total 4 A) ⁽³⁾ .
Built-in protection	Against inversions	Yes, by inverted diode ⁽⁴⁾ .
	Against short circuits and overloads	Yes, internal current limiter will limit output transience current at 7 A after internal over-temperature is detected
Pre-actuator voltage: monitoring threshold	OK	>19 Vdc (max.)
	Fault	<14 Vdc (typ.)
Pre-actuator voltage: monitoring response time	On appearance	2 ms<T<4 ms
	On disappearance	9 ms<T<11 ms
24 V pre-actuator consumption (excluding load current)	Typical	26 mA
	Maximum	35 mA
Dielectric strength	Between PLC bus and field sides	1,500 Vdc for 1 minute
Resistance of insulation		>10 MΩ (at 500 Vdc)

(1) 2.5A for ambient temperature under 60°C; 2A for ambient temperature from 60°C to 70°C

(2) All outputs are equipped with fast demagnetization circuits for electromagnets. Electromagnet discharge time < L/R.

(3) Users have to control the two parallel channels simultaneously to avoid overload on one channel.

(4) Provide a 12 A fuse to the +24 V pre-actuator supply.

 WARNING

LOSS OF OUTPUT FUNCTION

Do not implement the voltage over maximum limit value.

Failure to follow these instructions can result in death, serious injury, or equipment damage.

Output Fuses

Fuse	Value
Internal	None
External	1 fast blow fuse of 12 A for the output group

 CAUTION

LOSS OF OUTPUT FUNCTION

Install the correct rating and type of fuse.

Failure to follow these instructions can result in injury or equipment damage.

Connecting Discrete I/O Function

Description

The Discrete I/O function is fitted with a removable 28-pin terminal block (BMXFTB28x0) for the connection of 8 input channels and 12 output channels.

Input Circuit Diagram

The following diagram shows the circuit of a direct current input (positive logic).

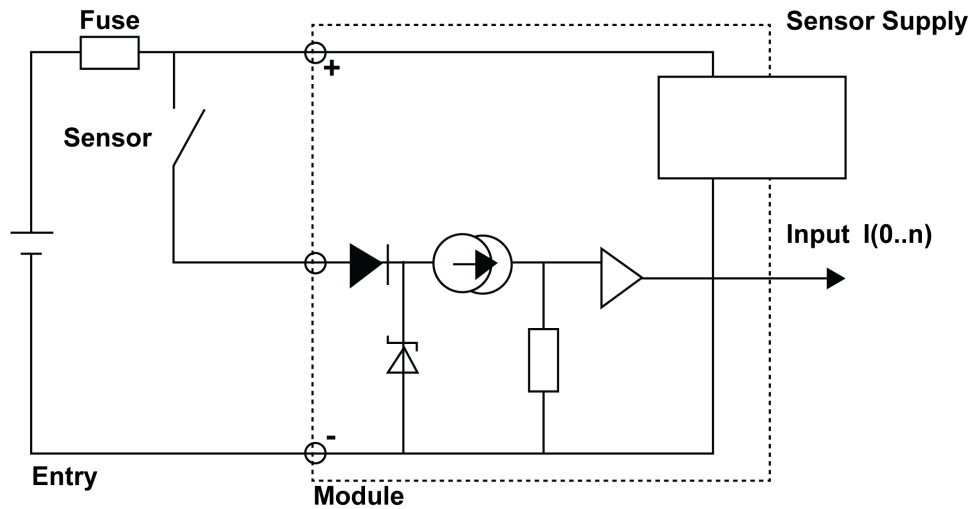

Output Circuit Diagram

The following diagram shows the circuit of a direct current output (positive logic).

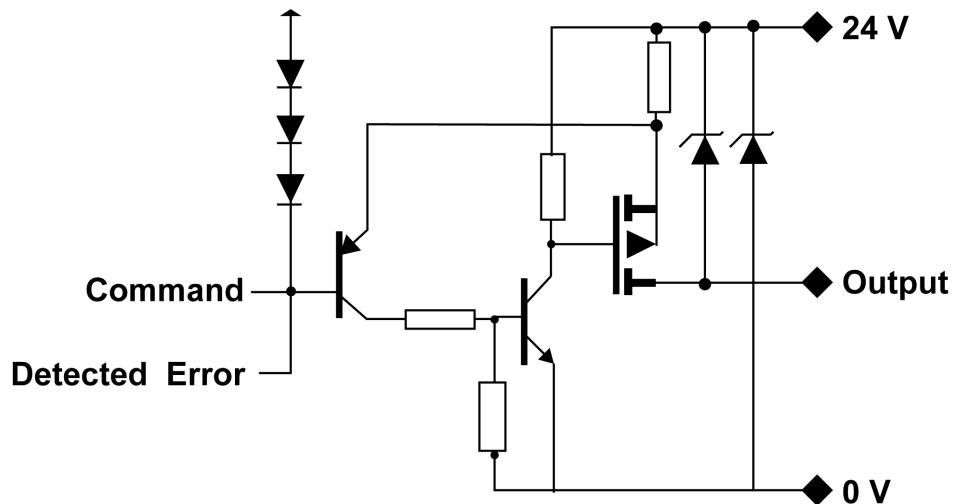

Discrete I/O Connection

The following diagram shows the connection of the function to the sensors and pre-actuators.

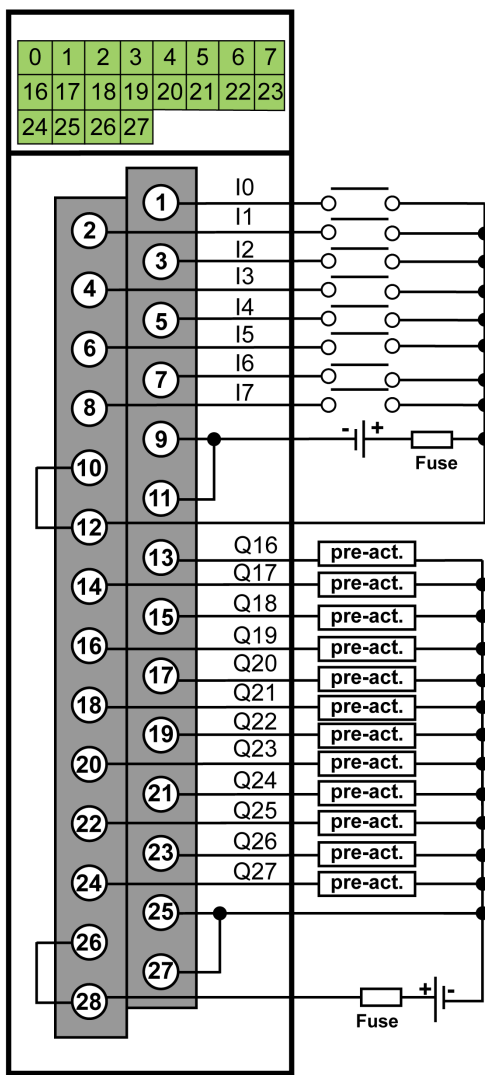

power supply: 24 Vdc
input fuse: fast blow fuse of 0.5 A
output fuse: fast blow fuse of 12 A
pre-act: pre-actuator

The following table lists the suitable terminal block references for Discrete Input & Output function:

I/O Function	Reference Number
Discrete Input & Output function	BMX FTB 28x0

NOTE: Make sure to follow the correct connection to the sensors and pre-actuators.

Fitting a 28-Pin Terminal Block

Installing the 28-Pin Terminal Block

The following table shows the assembling of the 28-pin terminal block onto I/O functions tightening torque 0.4 N•m (0.30 lb-ft):

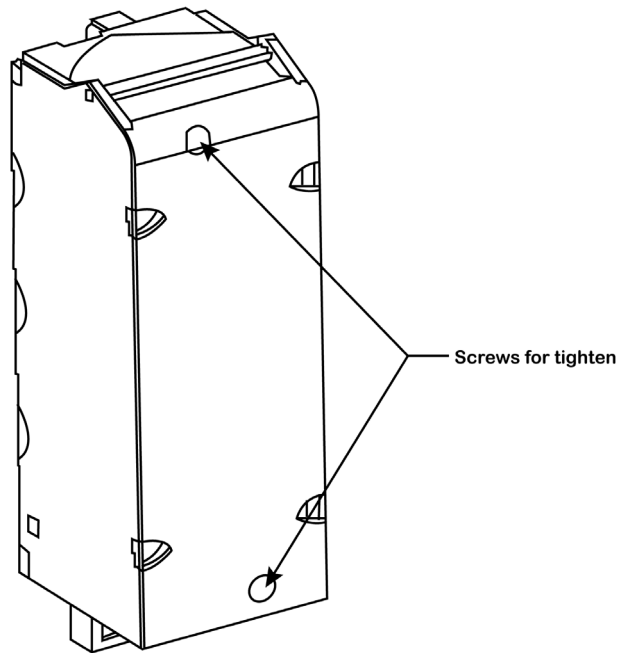

NOTE: If the screws are not tightened, the terminal block may not be properly fixed to the module.

28-Pin Terminal Block Modules

At a Glance

The Discrete I/O function is supplemented by a 28-pin terminal block.

There are two types of 28-pin terminal blocks:

- BMX FTB 2820 spring terminal blocks
- BMX FTB 2800 caged terminal blocks

Cable Ends and Contacts

The terminal block can accommodate:

- Bare wires

- Wires with DZ5-CE type cable ends:



Description of the 28-Pin Terminal Blocks

The table below shows the description of the 28-pin terminal blocks:

		Spring terminal blocks	Caged terminal blocks
Illustration			
Number of wires accommodated		1	1
Number of wire gauges accommodated	minimum	0.25 mm ² (AWG 24)	
	maximum	1.5 mm ² (AWG 16)	
Wiring constraints		The wires are connected by pressing on the button located next to each pin. To press on the button, you have to use a flat-tipped screwdriver with a maximum diameter of 3 mm.	Caged terminal blocks have slots that accept: <ul style="list-style-type: none"> • flat-tipped screwdrivers with a diameter of 3 mm, • posidriv n° 1 cross-tipped screwdrivers. Caged terminal blocks have captive screws. On the supplied blocks, these screws are not tightened.
Maximum screw tightening torque		-	0.5 N•m (0.37 lb-ft).
Temperature range of wire		Minimum 105 °C	

⚠ DANGER

ELECTRICAL SHOCK

The terminal block must be connected or disconnected with sensor and pre-actuator voltage switched off.

Failure to follow these instructions will result in death or serious injury.

Labeling of 28-Pin Terminal Blocks

Labels for the 28-pin terminal blocks are supplied with the module. They are to be inserted in the terminal block cover by the customer.

Each label has two sides:

- One side that is visible from the outside when the cover is closed. This side features the commercial product references, an abbreviated description of the module, as well as a blank section for customer labeling.
- One side that is visible from the inside when the cover is open. This side shows the terminal block connection diagram.

Discrete I/O Function (8 Input 12 Output) and Channel Status Display

Description

The Discrete I/O functions are equipped with a display block featuring LEDs that displays the functions channel status and the overall function status.

Representation

The below figure shows the LED indicator of the Discrete I/O function:

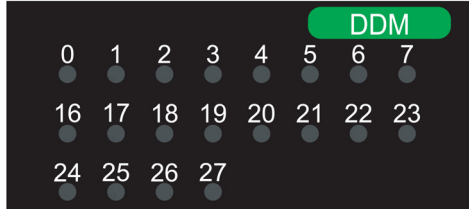

NOTE: The mixed input/output function has two groups of 8 input and 12 output channels. The input group is represented by channels 0...7 and the output group is represented by channels 16...27.

The following table helps you to perform diagnostics of the discrete I/O function status according to the channel LEDs:

Status		Meaning
0...7	16...27	
ON	-	Voltage is present on the input channel
-	ON	Voltage is present on the output channel
-	BLK	Actuator supply fails
-	FLK	Output channel is overload/short-circuit
Legends		
-		Not applicable
ON		LED is steady on
BLK (Blinking)		The LED is turned on for 200 ms, then turned off for 200 ms
FLK (Flickering)		The LED is turned on for 50 ms, then turned off for 50 ms

NOTE:

- Display of internal or external events is effective once the module is configured.
- When an event is detected, the channel status is recorded until the cause of the event is cleared.
- The output channel is closed by default.

⚠ WARNING
CHANNEL LED INFORMATION NOT MATCHING SENSORS VALUE
After a sensor power outage: <ul style="list-style-type: none"> • Do not take into account the input LEDs information (they show the last recorded value of the sensors, not their real value). • Check the real positions on the sensors.
Failure to follow these instructions can result in death, serious injury, or equipment damage.

Chapter 7

Analog Input Function

What Is in This Chapter?

This chapter contains the following topics:

Topic	Page
Analog Input Function Overview	50
Analog Input Functional Description	51

Analog Input Function Overview

Description

The Analog Input is a high level analog input function with four non-isolated channels. This function is used to measure and monitor the continuous process control functions.

The Analog Input function is available on these PLCs:

- BMK C80 20301
- BMK C80 30311

General Characteristics

These are the general characteristics of the Analog Input function:

Parameter		Characteristics
Type of inputs		High level Fast inputs with common point
Nature of inputs		Voltage/Current (250 Ω internally protected resistors)
Number of channels		4
Acquisition cycle time	Fast (periodic acquisition for the declared channels used)	1.3 ms + 1.3 ms x number of channels used
	Default (periodic acquisition for all channels)	6.5 ms
Display resolution (pk to pk resolution)		16-bit $\Sigma \Delta$
Digital filtering		1 st order
Isolation	Between channels	None
	Between channels and bus	1,400 Vdc
	Between channels and ground	1,400 Vdc
Maximum overload authorized for inputs	Voltage inputs	± 30 Vdc
	Current inputs	± 90 mA

NOTE: Help ensure that the inputs connected to the analog voltage and current channels are within the maximum load limit, else it will lead to the breakage of inputs.

Measurement Range

The Analog Input function has the following measurement range characteristics:

Measurement range	± 10 V; ± 5 V; 0...10 V; 0...5 V; 1...5 V	0...20 mA; 4...20 mA; ± 20 mA
Maximum conversion value	± 11.4 V	± 30 mA
Conversion resolution	0.35 mV	0.92 μ A
Input impedance	10 M Ω	250 Ω Internal conversion resistor
Precision of the internal conversion resistor	-	0.1% - ± 15 ppm/ $^{\circ}$ C
Measurement errors for standard function:		
At 25 $^{\circ}$ C	0.075% of FS ⁽¹⁾	0.15% of FS ⁽¹⁾⁽²⁾
Maximum in the temperature range - 25...70 $^{\circ}$ C (-13...158 $^{\circ}$ F)	0.2% of FS ⁽¹⁾	0.55% of FS ⁽¹⁾⁽²⁾
Temperature drift	15 ppm/ $^{\circ}$ C	30 ppm/ $^{\circ}$ C
Monotonicity	Yes	Yes
Crosstalk between channels DC and AC 50/60 Hz	>70 dB	>70 dB
Non-linearity	0.05% of FS	0.05% of FS
Repeatability @25 $^{\circ}$ C of 10 minutes stabilization time	0.005% of FS	0.007% of FS
Long term stability after 1000 hours	<0.004% of FS	<0.004% of FS
(1) FS: Full Scale		
(2) With conversion resistor error		

NOTE: If nothing is connected to an Analog Input function and if the channel is configured (range 4...20 mA or 1...5 V), an I/O error is detected in the form of broken wire.

Analog Input Functional Description

Description

The Analog Input function offers the following range for each input according to the selection made during configuration:

- ± 10 V
- 0...10 V
- 0...5 V/0...20 mA
- 1...5 V/4...20 mA
- ± 5 V/ ± 20 mA

The function operates with voltage inputs. It includes four read resistors connected to the terminal block to perform current inputs.

Measurement Timing

The timing of measurements is determined by the cycle selected during configuration (Normal or Fast Cycle):

- Normal Cycle means that the scan cycle duration is fixed.
- With the Fast Cycle, however, the system only scans the channels designated as being In Use. The scan cycle duration is therefore proportional to the number of channels In Use.

The cycle time values are based on the cycle selected:

Function	Normal Cycle	Fast Cycle
Analog input	6.5 ms	1.3 ms + (1.3 ms x N) where N: number of channels in use.

NOTE: Module cycle is not synchronized with the PLC cycle. At the beginning of each PLC cycle, each channel value is taken into account. If the MAST task cycle time is less than the module's cycle time, some values would have not changed.

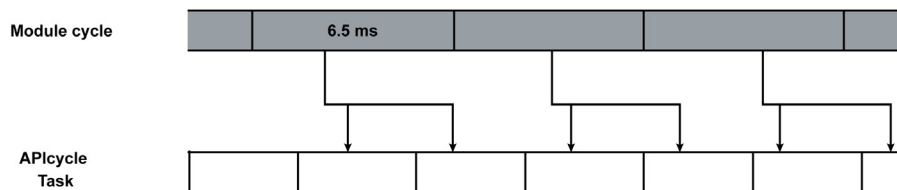

Overflow/Underflow Control

The Analog Input function allows you to select between six voltage or current ranges for each input. This option has to be configured in configuration windows for each channel.

The module checks for overflow depending on the selected range and verifies that the measurement falls between a lower and an upper threshold:

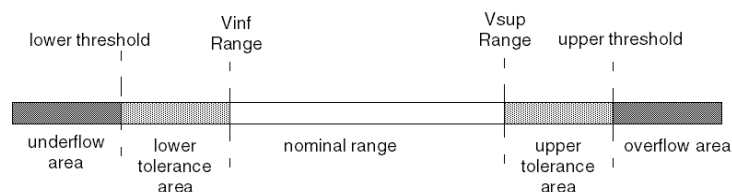

Designation	Description
Nominal range	Measurement range corresponding to the chosen range
Upper Tolerance Area	Varies between the values included between the maximum value for the range (for instance: +10 V for the ± 10 V range) and the upper threshold
Lower Tolerance Area	Varies between the values included between the minimum value for the range (for instance: -10 V for the ± 10 V range) and the lower threshold
Overflow Area	Area located beyond the upper threshold
Underflow Area	Area located beyond the lower threshold

The threshold values are configurable independently from one another. They may assume integer values between the following limits:

Range	Range									
	Underflow Area		Lower Tolerance Area		Nominal Range		Upper Tolerance Area		Overflow Area	
Unipolar										
0...10 V	-1,400	-1,001	-1,000	-1	0	10,000	10,001	11,000	11,001	11,400
0...5 V/0...20 mA	-5,000	-1,001	-1,000	-1	0	10,000	10,001	11,000	11,001	15,000
1...5 V/4...20 mA	-4,000	-801	-800	-1	0	10,000	10,001	10,800	10,801	14,000
Bipolar										
±10 V	-11,400	-11,001	-11,000	-10,001	-10,000	10,000	10,001	11,000	11,001	11,400
±5 V, ±20 mA	-15,000	-11,001	-11,000	-10,001	-10,000	10,000	10,001	11,000	11,001	15,000
User										
±10 V	-32,768	-	-	-	User-defined	User-defined	-	-	-	32,767
0...10 V	-32,768	-	-	-	User-defined	User-defined	-	-	-	32,767

Measurement Display

Measurements may be displayed using standardized display (in %, to two decimal places):

Type of Range	Display
Unipolar range 0...10 V, 0...5 V, 1...5 V, 0...20 mA, 4...20 mA	From 0...10,000 (0% at +100%)
Bipolar range ±10 V, ±5 V, ±20 mA	From -10,000...10,000 (-100% at +100%)

It is also possible to define the range of values within which measurements are expressed, by selecting:

- The lower threshold corresponding to the minimum value for the range: 0 % (or -100.00%).
- The upper threshold corresponding to the maximum value for the range (+100.00%).

The lower and upper thresholds must be integers between -32,768 and +32,767.

For example, imagine a conditioner providing pressure data on a 4...20 mA loop, with 4 mA corresponding to 3,200 millibar and 20 mA corresponding to 9,600 millibar. You have the option of choosing the User format, by setting the following lower and upper thresholds:

- 3,200 for 3,200 millibar as the lower threshold
- 9,600 for 9,600 millibar as the upper threshold

Values transmitted to the program vary between 3,200 (= 4 mA) and 9,600 (= 20 mA).

Measurement Filtering

The type of filtering performed by the system is called first order filtering. The filtering coefficient can be modified from a programming console or via the program.

The mathematical formula used is as follows:

$$\text{Meas}_{f(n)} = \alpha \times \text{Meas}_{f(n-1)} + (1-\alpha) \times \text{Val}_{b(n)}$$

where:

α = efficiency of the filter

$\text{Meas}_{f(n)}$ = measurement filtered at moment n

$\text{Meas}_{f(n-1)}$ = measurement filtered at moment n-1

$\text{Val}_{b(n)}$ = gross value at moment n

You may configure the filtering value from seven possibilities (from 0...6). This value may be changed even when the application is in RUN mode.

NOTE: Filtering may be accessed in Normal or Fast Cycle.

NOTE: $\alpha = e^{-T_{\text{cycle}}/t}$

where:

T_{cycle} = sampling period of the channel

τ = response time of the filter

The relation between the efficiency α and the Parameter k (0 to 6) is:

$\alpha = 0$ for $k=0$

$\alpha = 1 - 1/2^{k+1}$ for $k=1\dots6$

The filtering values depend on the T configuration cycle (where T = cycle time of 6.5 ms in standard mode):

Desired Efficiency	Required Value	Corresponding α	Filter Response Time at 63%	Cut-off frequency (Hz)
No filtering	0	0	0	-
Smooth filtering	1	0.750	4* T	0.040/T
	2	0.875	8* T	0.020/T
Average filtering	3	0.937	16* T	0.010/T
	4	0.969	32* T	0.005/T
High filtering	5	0.984	64* T	0.0025/T
	6	0.992	128* T	0.0012/T

NOTE: Enter the valid value for filter between the ranges 0...6. If you enter an invalid value in Device DDT, MC80 PLC will consider the last value of the filter.

Sensor Alignment

The process of alignment consists in eliminating a systematic offset observed with a given sensor, around a specific operating point. This operation compensates for an error linked to the process. Replacing a module does not therefore require a new alignment. However, replacing the sensor or changing the sensor's operating point does require a new alignment.

Conversion lines are as follows:

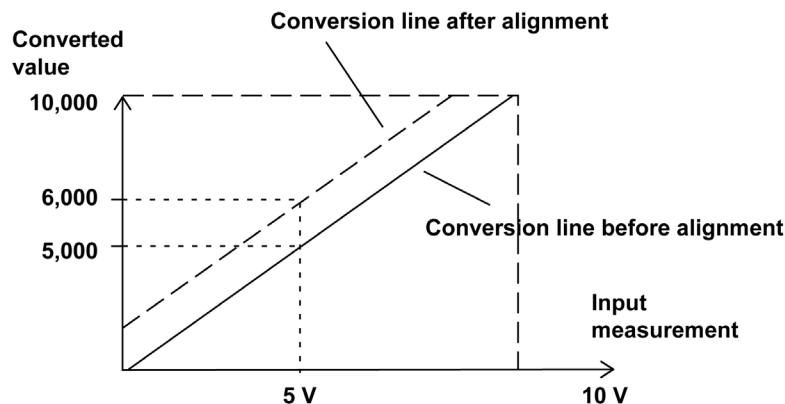

The alignment value is editable from a programming console, even if the program is in RUN Mode.

For each input channel, you can:

- view and modify the desired measurement value
- save the alignment value
- determine whether the channel already has an alignment

The alignment offset may also be modified through programming. Channel alignment is performed on the channel in standard operating mode, without any effect on the channel's operating modes.

The maximum offset between measured value and desired (aligned) value may not exceed $\pm 1,500$.

NOTE: To align several analog channels, we recommend to proceed channel by channel. Test each channel after alignment before moving to the next channel in order to apply the parameters correctly.

NOTE: Enter the valid value for the filter. The valid value is between the predefined ranges. If you enter an invalid value in Device DDT, MC80 PLC will consider the upper or lower limit from the predefined range.

Wiring Precautions

In order to protect the signal from outside interference induced in series mode and interference in common mode, we recommend that you take the following precautions:

- Cable Shielding - Connect the cable shielding to the grounding bar. Clamp the shielding to the grounding bar on the module side.

For more details on grounding, refer to the chapter Grounding Bar *(see page 77)*.

⚠ DANGER
HAZARD OF ELECTRIC SHOCK, EXPLOSION, OR ARC FLASH
While mounting / removing the modules:
<ul style="list-style-type: none">● Make sure that each terminal block is still connected to the grounding bar● Disconnect voltage supplying sensors and pre-actuators.
Failure to follow these instructions will result in death or serious injury.

⚠ WARNING
UNEXPECTED EQUIPEMENT OPERATION
<ul style="list-style-type: none">● Use a 24 Vdc supply to sensors and a shielded cable for connecting the sensors to the module.
Failure to follow these instructions can result in death, serious injury, or equipment damage.

⚠ DANGER
HAZARD OF ELECTRIC SHOCK
Sensors and other peripherals may be connected to a grounding point some distance from the module. Such remote ground references may carry considerable potential differences with respect to local ground. Ensure that:
<ul style="list-style-type: none">● potentials greater than permitted low limits cannot exist,● induced currents do not affect the measurement or integrity of the system.
Failure to follow these instructions will result in death or serious injury.

Electromagnetic Hazard Instructions

⚠ CAUTION
UNEXPECTED BEHAVIOR OF APPLICATION
Follow these instructions to reduce electromagnetic perturbations:
<ul style="list-style-type: none">● Use the BMX XSP 0400/0600/0800/1200 electromagnetic protection kit to connect the shielding.
Electromagnetic perturbations may lead to an unexpected behavior of the application.
Failure to follow these instructions can result in injury or equipment damage.

Wiring Diagram

The Analog Input Function is connected using the 20-pin terminal block (BMXFTB20x0).

This figure shows the terminal block connection and the sensor wiring:

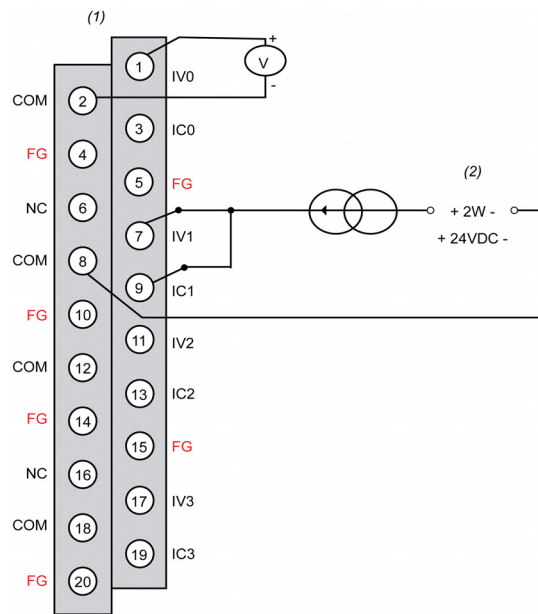

- IVx:** pole input for channel x
- COM:** common pin for each channel
- ICx:** current reading resistor + input
- FG** functional ground

This table lists the suitable terminal block references for Analog Input function:

I/O Function	Reference Number
Analog Input function	BMX FTB 2000 BMX FTB 2010 BMX FTB 2020

LED Indicator

The LED indicator shows the status of the AI channels.

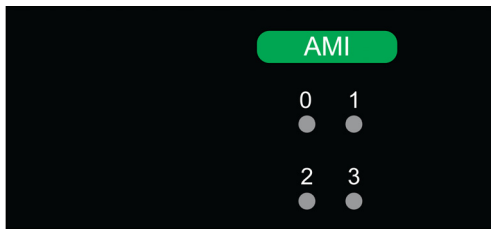

Use this table to perform diagnostics of the analog input function status according to the channel LEDs:

Status LEDs AMI Function	Function Status
IN Channel	
ON	Operating normally
OFF	Module is running with channels in stopped state
OFF	Module is inoperative or turned off
OFF	Module not configured or channel configuration in progress
OFF	Internal error in module
OFF	Not configured
BLK	Range under/overflow error
FLK	Sensor link error
Legends	
ON	LED is turned on
OFF	LED is turned off
FLK (Flickering)	The LED is turned on for 50 ms then turned off for 50 ms, and then repeat
BLK (Blinking)	The LED is turned on for 200 ms then turned off for 200 ms, and then repeat

For more information, refer to *“Fitting a 20-Pin Terminal Block”* (see page 35).

Chapter 8

High Speed Counting Input and Output Function

What Is in This Chapter?

This chapter contains the following topics:

Topic	Page
High Speed Counting Input and Output Function	58
Display and Diagnostics of the High Speed Counting Function	60
HSC Function Wiring	61
Fitting a 28-Pin Terminal Block	63
28-Pin Terminal Block Modules	64

High Speed Counting Input and Output Function

Description

The MC80 PLC's High Speed Counting Input and Output (HSC I/O) function is an equivalent function like M340 EHC0200, which is compatible with the Control Expert software and operates up to 60 kHz.

The function provides two channels and each channel provides six digital inputs and two digital outputs and contains programmable blocks.

The counter operates in one of nine user-configurable modes, which may be selected by using the Control Expert configuration tool.

This HSC I/O function is available on the BMK C80 30311 PLC.

General Characteristics

The following table shows the general characteristics of the HSC I/O function:

Characteristic	Description	Value
Function type		2 counting channels
Maximum frequency at counting inputs		60 KHz
Counting depth		32 bits
Number of digital inputs/outputs per counting channel	Inputs	3 fast inputs 24 Vdc Type 1 3 normal inputs 24 Vdc Type 3
	Outputs	2 outputs 24 Vdc
Power supply	Sensor power voltage	19...30.0 Vdc
	Sensor power current (12 inputs on)	Typical 70 mA Maximum 77 mA
	Sensor power supply reverse polarity protection	Yes, by reverse-mounted diode. Use an external fast blow fuse.
	Pre-actuator power supply (without load current)	Typical 15 mA Maximum 20 mA
	Pre-actuator power supply reverse polarity protection	Yes. By reverse-mounted diode. Use an external fast blow fuse.
	Actuator power current	0.625 A maximum per output
Power distribution to sensors		Yes with short-circuit and overload protection. Typical 300 mA (short-circuit limited to 2.5 A)
Encoder compliance		Complies with most encoders that have a supply of between 15 V and 30 V and push-pull outputs
Insulation voltage of the ground to the bus		1,500 V rms for 1 minute

Input Characteristics

The following table lists general characteristics of the input channels for the function:

Characteristic	Description	
Number of input Channels	Six 24 Vdc inputs per counting channel	
IN EN, IN REF, IN CAP	Maximum input voltage	30 Vdc continuous
	On input voltage	+11...+30 Vdc
	Off input voltage	up to +5 Vdc
	Off input current	up to 1.5 mA
	On input current	(Up to 30 Vdc) 5 mA
	Current at 11 Vdc	>2 mA

Characteristic	Description	
IN A, IN B, IN SYNC	Maximum input voltage	30 Vdc continuous
	On input voltage	+15...+30 Vdc
	Off input voltage	up to +5 Vdc
	Off input current	up to 1.5 mA
	On input current	(Up to 30 Vdc) 5 mA
	Current at 15 Vdc	>2 mA
Input response time	Refer to the input filter and bounce filter tables.	
Sensor power supply monitor	Ok	>19 V (max.)
	Fault	<14 V (typ.)

Output Characteristics

The following table lists the general characteristics of the output channels for the function:

Characteristic	Description	
Number of outputs per channel	2	
Type	24 Vdc transistor source	
Output voltage	19...30.0 Vdc	
Maximum load current	Each point	0.625 A
	Output group	2.5 A
Off state leakage/point	<0.5 mA	
On state output voltage drop	<1.2 V	
Short circuit output current	At each point current limited at 0.7 A<Id<1.7 A, after internal over-temperature is detected.	
Maximum load capacity	50 µF	
Maximum inductive load	The inductive load is calculated using the following formula: $L = 0.5/I^2 \times F$ where: L = load inductance (Henry) I = load current (A) F = switching frequency (Hz)	
Maximum response time	<600 µs	
Output protection (internal)	Transient voltage suppression	
Short circuit	Protection/status per channel. Overload/short-circuit is reported only when consequent over-temperature happens on output drivers.	
Fallback value (output channels)	Default	Predefined fallback values on both channels
	User-configurable settings	Hold last value Predefined fallback value on one or both channels
Fallback states for output channels (when predefined is the fallback mode)	Default	Both channels go to 0
	User-configurable settings	Each channel configurable for 1 or 0
Polarity on individual output channels	Default	Logic normal on both channels
	User-configurable settings	Logic reverse on one or both channels
		Logic normal on one or both channels
Pre-actuator power supply monitor	OK	>19 V (max.)
	Error	<14 V (typ.)
Output paralleling	Yes (2 channels maximum and total 1 A maximum)	

NOTE: The two paralleled channels have to be controlled simultaneously in Control Expert application to avoid overload on one channel.

Display and Diagnostics of the High Speed Counting Function

Description

The HSC counting module has LEDs that enable the status of the module to be viewed.

The LEDs for inputs/outputs of each channel are:

- State LED for inputs of each channel: IA, IB, IS, IE, IP, IC.
- State LED for outputs of each channel: Q0, Q1.

Representation

The below figure shows the LED indicator of the HSC function:

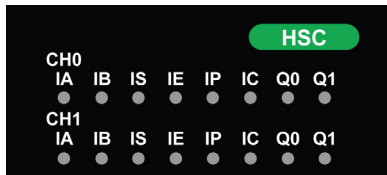

Function Diagnostics

The following table presents the various function states according to the LED states (empty cell indicates that the pattern on the associated LED can be ignored):

LED indicators								Function Status	
IA	IB	IS	IE	IP	IC	Q0	Q1		
BLK					-	-	-	Sensor supply fails	
-	-	-	-	-	-	BLK		Actuator supply fails	
-	-	-	-	-	-	FLK	-	OUT 0 has a Short Circuit	
-	-	-	-	-	-	-	FLK	OUT 1 has a Short Circuit	
ON	-	-	-	-	-	-	-	The voltage is present on IA	
-	ON	-	-	-	-	-	-	The voltage is present on IB	
-	-	ON	-	-	-	-	-	The voltage is present on IS	
-	-	-	ON	-	-	-	-	The voltage is present on IE	
-	-	-	-	ON	-	-	-	The voltage is present on IP	
-	-	-	-	-	ON	-	-	The voltage is present on IC	
-	-	-	-	-	-	ON	-	The voltage is present on Q0	
-	-	-	-	-	-	-	ON	The voltage is present on Q1	
Legends									
ON								LED is turned on	
OFF								LED is turned off	
FLK (Flickering)								The LED is turned on for 50 ms then turned off for 50 ms	
BLK (Blinking)								The LED is turned on for 200 ms then turned off for 200 ms	

HSC Function Wiring

Description

The MC80 PLC's HSC IO function is connected using the 28-pin terminal block (BMXFTB28x0).

⚠ DANGER

HAZARD OF ELECTRIC SHOCK

- Disconnect voltage supplying sensors and pre-actuators before plugging/unplugging the terminal block on the module.
- Remove the terminal block before plugging/unplugging the module on the rack.

Failure to follow these instructions will result in death or serious injury.

Assignment of the 28-Pin Connector

The below figure shows the physical location of the pin numbers for the 28-pin connector:

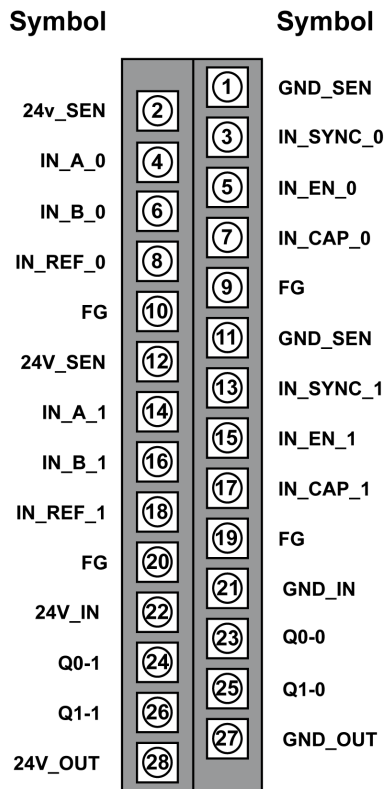

28-pin Connector

The symbol and description of each pin are described in the table below:

Pin Number	Symbol	Description
2,12	24V_SEN	24 Vdc output for sensors supply
1,11	GND_SEN	24 Vdc output for sensors supply
9,10,19,20	FG	Functional ground
4,14	IN_A_0 IN_A_1	Input A
6,16	IN_B_0 IN_B_1	Input B
3,13	IN_SYNC_0 IN_SYNC_1	Synchronization input
5,15	IN_EN_0 IN_EN_1	Enable input
8,18	IN_REF_0 IN_REF_1	Homing input
7,17	IN_CAP_0 IN_CAP_1	Capture input
22	24V_IN	24 Vdc input for sensors supply

Pin Number	Symbol	Description
21	GND_IN	24 Vdc input for sensors supply
23	Q0-0	Q0 output for counting channel 0
24	Q0-1	Q1 output for counting channel 0
25	Q1-0	Q0 output for counting channel 1
26	Q1-1	Q1 output for counting channel 1
28	24V_OUT	24 Vdc input for actuators supply
27	GND_OUT	24 Vdc input for actuators supply

The following table lists the suitable terminal block references for High Speed Counting function:

I/O Function	Reference Number
High Speed Counting function	BMX FTB 2800 BMX FTB 2820

Fitting a 28-Pin Terminal Block

Installing the 28-Pin Terminal Block

The following table shows the assembling of the 28-pin terminal block onto I/O functions tightening torque 0.4 N•m (0.30 lb-ft):

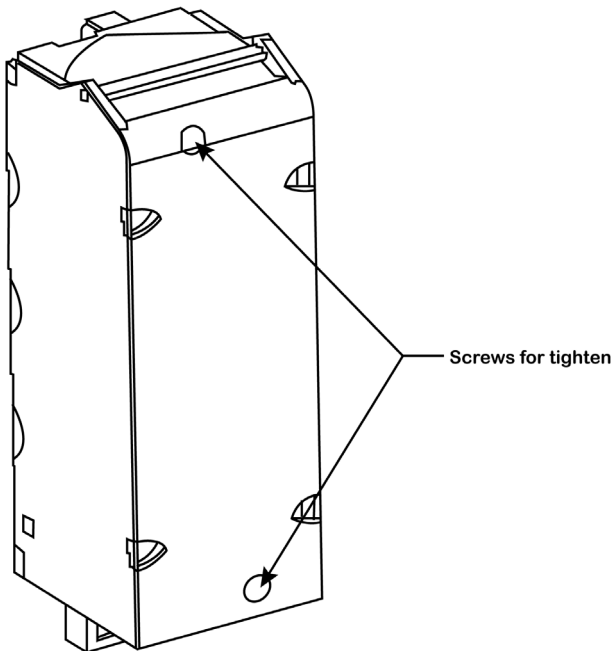

NOTE: If the screws are not tightened, the terminal block may not be properly fixed to the module.

28-Pin Terminal Block Modules

At a Glance

The High Speed Counting function is supplemented by a 28-pin terminal block.

There are two types of 28-pin terminal blocks:

- BMX FTB 2820 spring terminal blocks.
- BMX FTB 2800 caged terminal blocks.

Cable Ends and Contacts

The terminal block can accommodate:

- Bare wires
- Wires with DZ5-CE type cable ends:



Description of the 28-Pin Terminal Blocks

The table below shows the description of the 28-pin terminal blocks:

		Spring terminal blocks	Caged terminal blocks
Illustration			
Number of wires accommodated		1	1
Number of wire gauges accommodated	minimum	0.25 mm ² (AWG 24)	
	maximum	1.5 mm ² (AWG 16)	
Wiring constraints		The wires are connected by pressing on the button located next to each pin. To press on the button, you have to use a flat-tipped screwdriver with a maximum diameter of 3 mm.	Caged terminal blocks have slots that accept: <ul style="list-style-type: none"> • flat-tipped screwdrivers with a diameter of 3 mm, • posidriv n° 1 cross-tipped screwdrivers. Caged terminal blocks have captive screws. On the supplied blocks, these screws are not tightened.
Maximum screw tightening torque		-	0.5 N•m (0.37 lb-ft).
Temperature range of wire		Minimum 105 °C	

⚠ DANGER

ELECTRICAL SHOCK

The terminal block must be connected or disconnected with sensor and pre-actuator voltage switched off.

Failure to follow these instructions will result in death or serious injury.

Labeling of 28-Pin Terminal Blocks

Labels for the 28-pin terminal blocks are supplied with the module. They are to be inserted in the terminal block cover by the customer.

Each label has two sides:

- One side that is visible from the outside when the cover is closed. This side features the commercial product references, an abbreviated description of the module, as well as a blank section for customer labeling.
- One side that is visible from the inside when the cover is open. This side shows the terminal block connection diagram.

Sensor Connections

The example below shows three-wire input devices used on inputs IN_A and IN_B and two-wire devices used on inputs IN_EN and IN_SYNC:

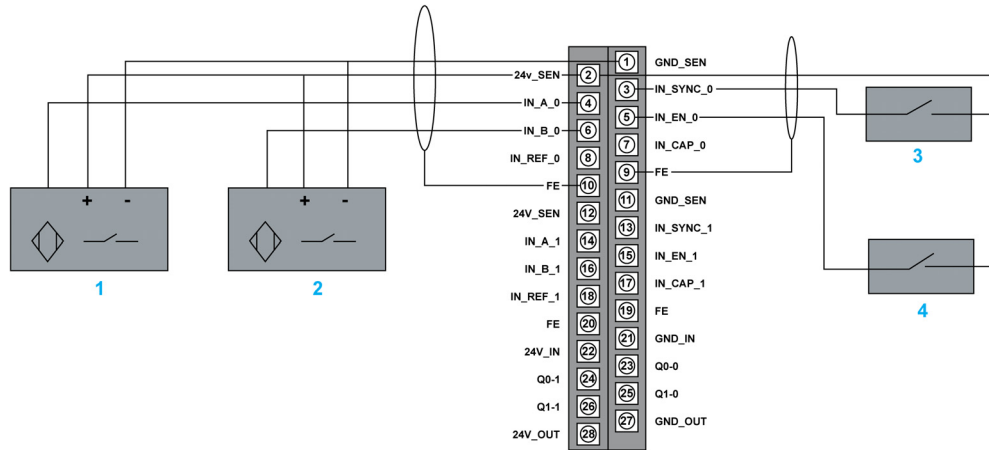

- 1 IN_A input
- 2 IN_B input
- 3 IN_SYNC input (synchronization input)
- 4 IN_EN input (enable input)

Encoder Connection

The example below shows an incremental encoder used for axis control and the three auxiliary inputs used especially for largest mode (Free Large Counting):

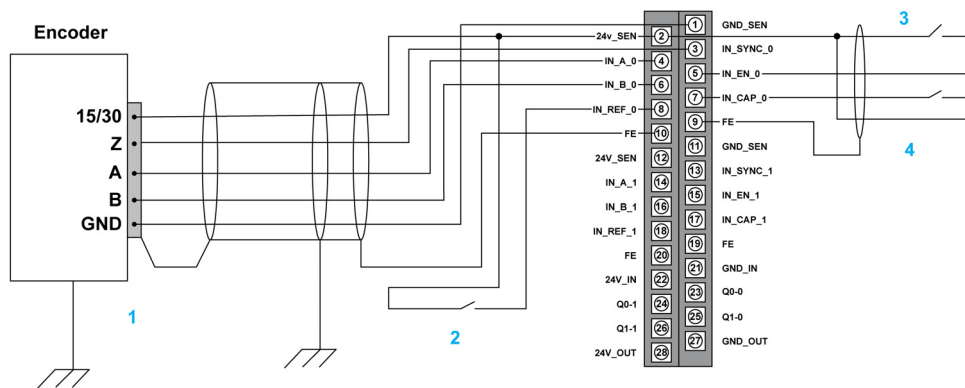

- 1 Encoder (inputs A, B and Z)
- 2 IN_REF input (homing input)
- 3 IN_EN input (enable input)
- 4 IN_CAP input (capture input)

Connecting Outputs and Output Supplies

The figure below shows the connection of supplies and actuators to the 28-pin connector:

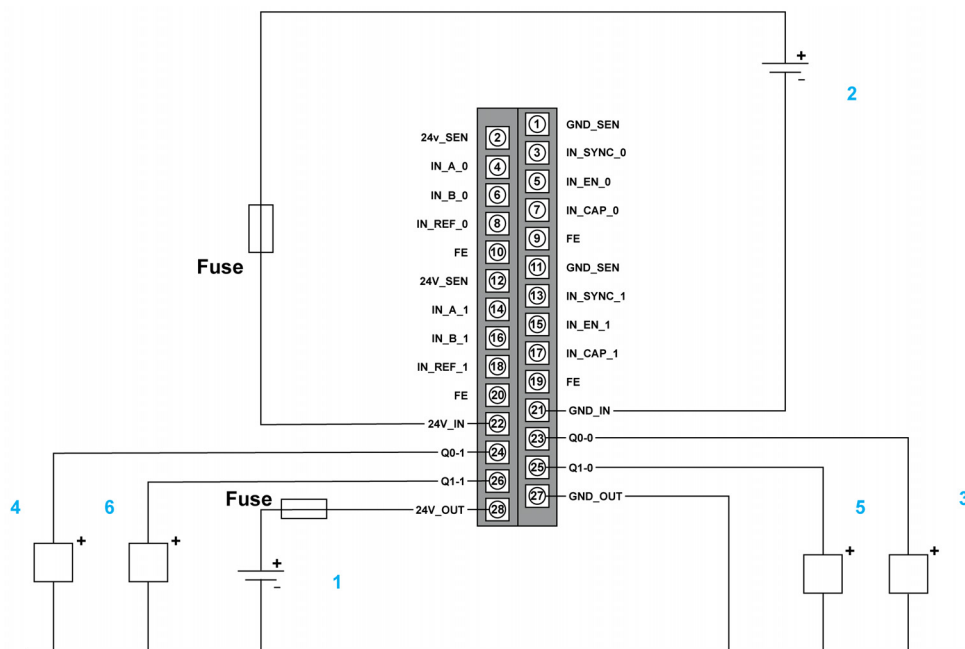

- 1 24 V supply for actuators
- 2 24 V supply for sensors
- 3 Actuator for the Q0 output of counting channel 0
- 4 Actuator for the Q1 output of counting channel 0
- 5 Actuator for the Q0 output of counting channel 1
- 6 Actuator for the Q1 output of counting channel 1

Chapter 9

Communication

What Is in This Chapter?

This chapter contains the following topics:

Topic	Page
Communication	68
Serial Link	69
Ethernet Link	71
CANopen Link	74
USB Link	76

Communication

Description

The communication functions available in MC80 controller are:

- Serial link
- Ethernet port
- CANopen link

Representation

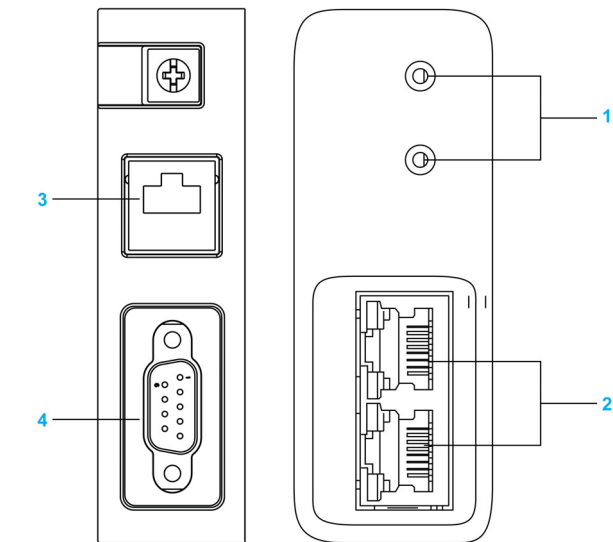

- 1 Rotary switches
- 2 Ethernet ports
- 3 Serial link
- 4 CANopen link

Serial Link

Description

Serial link is a communication protocol in which the serial port can be configured as RS485 or RS232 by Control Expert. The serial link is used for connecting the HMI, modem, and other serial devices.

The following table describes the characteristics of the serial communication channels:

Characteristic	Description
Protocols supported	<ul style="list-style-type: none"> • Modbus protocol (RTU and ASCII) • Character mode protocol
Connection	Shielded RJ45 connector
Physical link	<ul style="list-style-type: none"> • RS485 non-insulated serial link • RS232 non-insulated serial link

The following table shows the specification of Modbus link:

Characteristic	Description	Value
Serial link physical spec.	Baud Rate	300...19,200 bps
	Connector type	Shielded RJ45
	Interface	RS232, RS485 software configurable
	Connection Media	2-wire RS485 RS232 with or without RTS, CTS handshaking signals.
	Mode of Operation	Master/Slave
	Polarization	Software configurable polarization on RS485 in character mode.
	RS232 type	DTE
	5 Vdc output power	Voltage tolerance: $\pm 10\%$ Maximum current: 190 mA
Max. cable length	RS232: 15 m RS485: <ul style="list-style-type: none"> • 10 m non-isolated link • 1,000 m isolated link (For an isolated link, the TWD XCA ISO isolation box must be used.)	

The following figure shows the LED indicator of the Serial Communication:



The following table lists the definition of the LED indicator:

Label	Color	Description
SER COM	Yellow	Indicates the communication activity of serial link

The following table describes the LED pattern and the indication:

LED	Pattern	Indication
SER COM (yellow): serial data status	flashing	Data exchange on the serial connection is in progress (receiving or sending)
	off	No data exchange on the serial connection

Representation

The following figure shows the RJ45 serial port:

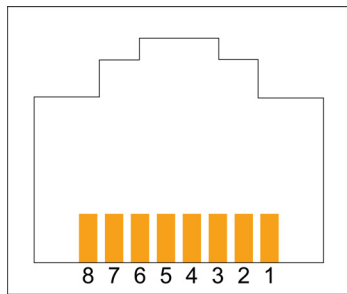

The below table lists the pin assignment of RJ45 connector:

RJ45 Pin No.	RS232 Signal Name	RS485 Signal Name
1	RXD	Reserved
2	TXD	Reserved
3	RTS	Reserved
4	Reserved	D1
5	Reserved	D0
6	CTS	Reserved
7	5 V output	5 V output
8	GND	GND

NOTE: The RS232 4-wire, RS485 2-wire, and power supply cables all use the same RJ45 connectors. MC80 PLC can use TWDXCAISO module as an isolation solution.

Ethernet Link

Description

The MC80 PLC have two Ethernet ports dedicated to Ethernet communication with two rotary switches which enable easy selection of the IP address.

The following table shows the specification of the Ethernet link:

Characteristic	Description	Value
Di-electric strength	Ethernet	1,500 Vdc between logic common and twisted pair (@0...2,000 m altitude).
Ethernet port physical spec.	Connector Type	Dual shield RJ45 connectors
	Speed	10Base-T, 100Base-TX
	Auto Negotiation	Supported
	Auto MDI/MDI-X	Supported
	Addressing	Unique IEEE Global (MAC) Address. User assigned IP Address
	Mode of Operation	Master/Slave, Half/Full duplex
	Topology	Star, Daisy chain
	Media	Copper (Twisted pair)
	Isolation support	Yes

The figure below shows the LED indicator of the Ethernet Communication:



The following table lists the definition of the LED indicators:

Label	Color	Description
ETH STS	Green	Indicates the Ethernet port operation states

The ETH STS is located on the ETH led panel.

The following table describes the LED pattern and the indication:

LED	Pattern	Indication
ETH LNK/ACT (green)	on	Ethernet link is detected and there is no communication activity
	off	No Ethernet link is detected
	Flashing	Data exchange on the Ethernet link is in progress
ETH 100	green	Ethernet transmission is at 100 Mb/s (Fast Ethernet)
	yellow	Ethernet transmission is at 10 Mb/s
	off	No link is detected
ETH STS (green): Ethernet communication status	off	No communication activity
	on	Communication is OK
	2 flashes	Invalid MAC address
	3 flashes	Ethernet link is not connected
	4 flashes	Duplicate IP Address
	5 flashes	Waiting for server IP address
	6 flashes	Safe Mode - At default IP address
7 flashes	Configuration conflict between rotary switches and internal configuration	

The below figure shows the LED indicator of the Ethernet Communication (connector):

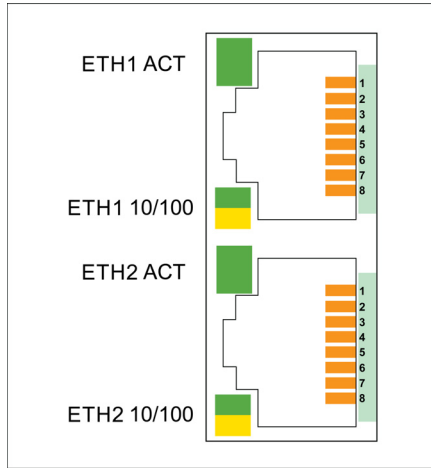

The following table lists the definition of the embedded LED on the RJ45 connector:

Label	Color	Description
ETH1 ACT	Green	Indicates the activity of Ethernet port1
ETH1 10/100	Green	Indicates the speed of Ethernet port1 which is 100 Mbps
	Yellow	Indicates the speed of Ethernet port1 which is 10 Mbps
ETH2 ACT	Green	Indicates the activity of Ethernet port2
ETH2 10/100	Green	Indicates the speed of Ethernet port2 which is 100 Mbps
	Yellow	Indicates the speed of Ethernet port2 which is 10 Mbps

Representation

The following figure shows the RJ45 Ethernet port:

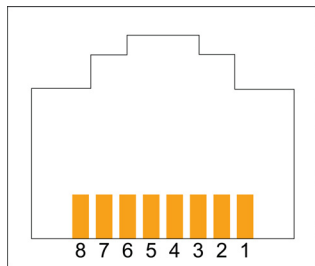

The following table lists the pin assignment of the RJ45 Ethernet port:

Pin No.	Signal Name
1	TD+
2	TD-
3	RD+
4	Not connected
5	Not connected
6	RD-
7	Not connected
8	Not connected

Rotary Switches

The purpose of the two rotary switches is to select an IP address. To set an IP address, rotate the arrow firmly into the desired position.

NOTE: If you do not feel the switch click into place, the value of the switch may be incorrect or undetermined.

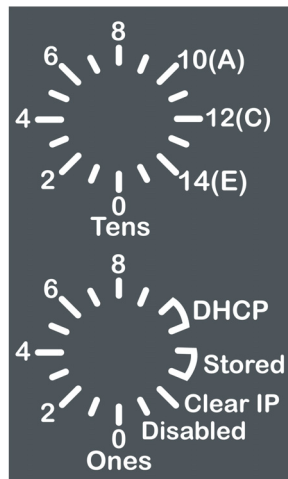

Switch Settings

This table describes the switch settings:

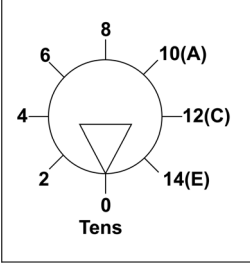
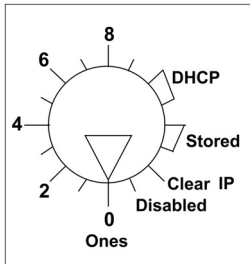
Rotary Switch	Numbers	Description
Upper switch 	0...9	Tens value for the device name (0, 10, 20, ..., 90)
	10(A)...15(F)	Tens value for the device name (100, 110, 120, ..., 150)
Lower switch 	0...9	Ones value for the device name (0, 1, 2, ..., 9)
	DHCP	Set the lower rotary switch to one of its DHCP positions to perform a DHCP request that has a MAC address as Client Identify.
	Stored	The lower rotary switch is set to STORED (default setting) to use the application's configured parameters. <ul style="list-style-type: none"> Configure static IP Configure Device Name to get IP address through DHCP NOTE: When the Device Name is empty, MC80 will use MAC address to get IP address.
	Clear IP	The lower rotary switch is set to CLEAR IP to use the MAC-based default IP address. The default IP address format is 10.10.x.x <ul style="list-style-type: none"> 10.10: is a fixed value x: The last two fields in the default IP address are composed of the decimal equivalents of the last two hexadecimal bytes in the MAC address.
	Disabled	Set the switch to Disabled to disable communications.

Device Name Naming Rules

There are three components of the device name. The default device name of the module is:
 BMK C80 20310 : BMK_20310_xxy
 The numeric value between 00 and 159 is set on the rotary switches. (For the default device name, xx is the value of the upper rotary switch and y is the value of the lower rotary switch.)
 For example: For a BMK C80 20310 module, values of 120 (12 x 10) and 6 (6 x 1) on the respective upper and lower rotary switches indicate a value of 126. The value is appended to the default device name (BMK_20310_xxy) to create the valid DHCP device name of BMK_20310_126.

NOTE: The selection on the lower switch of any non-numeric parameter (DHCP, STORED, CLEAR IP, DISABLED) makes the setting on the upper switch inconsequential.

NOTE: Make sure to restart the PLC after changing the rotary switch position.

CANopen Link

Description

The CANopen port is a built-in communication channel dedicated to CANopen communication. The CANopen port of the processor module is fitted with a SUB-D9 connection.

The following table shows the specification of the CANopen link:

Characteristic	Description	Value
Di-electric strength	CANopen	500 Vac or 700 Vdc between logic common and CANopen (@0...2,000 m altitude).
CANopen physical spec.	Type	Master
	Address range	1...16 (16 slaves max. on the CPU)
	Baud Rate	1 Mbps, 500 kbps, 250 kbps, 125 kbps, 50 kbps, 20 kbps
	Connector type	Shielded D-SUB 9
	Isolation support	Yes

The following figure shows the LED indicator of the CANopen Communication:



The following table lists the definition of the LED indicators:

Label	Color	Description
CAN RUN	Green	Indicates the CANopen operation status
CAN ERR	Red	Indicates the detected errors on CANopen

NOTE: The priority of CANopen led status is: on > 2 flashes > 1 flash > flashing > off.

The following table describes the LED pattern and the indication:

LED	Pattern	Indication
CAN RUN (green): CANopen operation	on	CANopen network is operational
	slow flashing (on for 200 ms, off for 200 ms, repeating)	CANopen network is pre-operational, or master being alone
	1 flash	CANopen network is stopped
	off	CANopen is not configured
CAN ERR (red): CANopen detected errors	on	<ul style="list-style-type: none"> ● CANopen bus is stopped, CAN controller has status "BUS OFF" ● Not configured
	slow flashing (on for 200 ms, off for 200 ms, repeating)	<ul style="list-style-type: none"> ● CANopen configuration is not valid ● Invalid configuration ● Logic configuration is different from physical configuration. For example, missing or different slaves are detected.
	1 flash	One of the detected error counters has reached or exceeded the alert level
	2 flashes	A heartbeat event has taken place
	off	No CANopen error

Representation

The following figure shows the CANopen port and the pin labels:

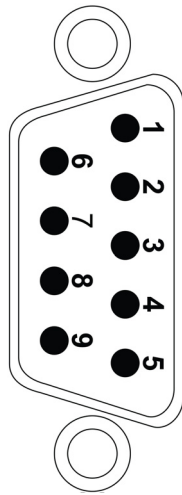

The following table lists the pin assignment of CANopen port:

Pin No.	Signal Name
1	Reserved
2	CAN_L
3	CAN_GND
4	Reserved
5	Reserved
6	GND
7	CAN_H
8	Reserved
9	Reserved

USB Link

Description

The USB port is a default terminal connection for application download/upload, programming tool (Control Expert) connection and so on. The USB port is USB 2.0 type which uses a mini-B type shield connector.

The following table shows the specification of the USB link:

Characteristic	Description	Value
USB physical spec.	Type	USB 2.0 Device
	Speed mode	Full speed mode (12 Mbps)

Representation

The following figure shows the USB port and the pin labels:

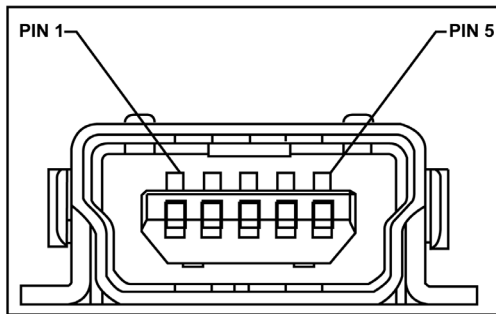

The below table lists the pin assignment of USB port:

Pin No.	Signal Name
1	VBUS
2	DM
3	DP
4	Reserved
5	Ground

NOTE: To avoid unexpected behavior of the PLC, always use one of the following shielded cable USB that comply the international standard:

- BMX XCA USB 018
- BMX XCA USB 045

Chapter 10

Grounding of PLC

Grounding of PLC

Description

The grounding of MC80 PLC is important to avoid electric shock and the configuration involves the grounding screw and power supply terminal.

⚠ WARNING

UNINTENDED EQUIPMENT OPERATION

Tighten the clamping screws of the modules. A break in the circuit could lead to an unexpected behavior of the system.

Failure to follow these instructions can result in death, serious injury, or equipment damage.

Grounding the Protective Earth (PE) terminal of PLC

Protective grounding must be performed by connecting the grounding screw located on the left-hand side of the product to the earth of installation.

Two cables of $\varnothing 3$ mm maximum can be connected using grounding screw.

Grounding the Power Supply Terminal (FG)

The Functional Ground (FG) located on the power supply must be connected to the earth of installation in one of the following two ways:

- Using a separate cable that is independent of the Protective Earth, and directly connected to the earth of installation.
- Or
- Using a cable that connects the Protective Earth (PE) terminal.

⚠ DANGER

HAZARD OF ELECTRIC SHOCK

Power supply terminal must be grounded. Do not connect anything else to the power supply ground.

Failure to follow these instructions will result in death or serious injury.

Representations

The following figure shows the ground connection between grounding screw and FG of power supply using two independent ground cables.

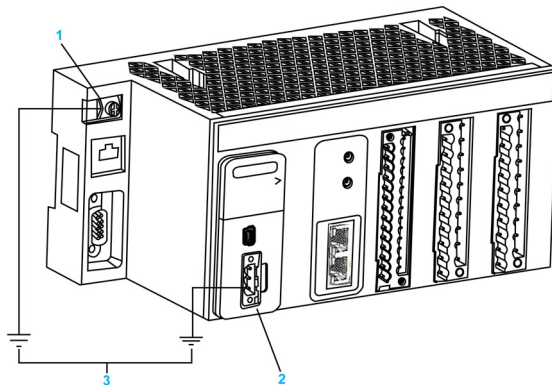

- 1 Grounding Screw (Maximum tighten torque: 1.5 N•m (1.1 lb-ft))
- 2 Power Supply Terminal Block
- 3 Earth of installation

The following figure shows the ground connection between grounding screw and FG of power supply.

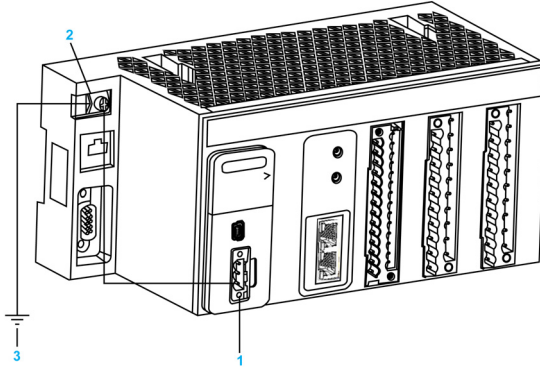

- 1 Power Supply Terminal Block
- 2 Grounding Screw (Maximum tighten torque: 1.5 N•m (1.1 lb-ft))
- 3 Earth of installation

⚠ DANGER

HAZARD OF ELECTRIC SHOCK

Use only cables with ring or spade lugs to ensure connection to ground. Ensure grounding hardware is tightened properly.

Failure to follow these instructions will result in death or serious injury.

Grounding Bar

To guarantee protection against electromagnetic interferences, the cable shielding is directly connected to the ground.

NOTE: The cable shielding is not connected to the module shielding.

This connection can be made using any method but a protection bar is provided in order to facilitate the set up.

A protection bar is used in two cases:

- counting module with 28-pin terminal blocks
- analog module with 20-pin terminal block

The STB grounding bar references are listed below:

Reference	Description
STBXSP3000	SHD KIT BRACKETS AND BAR
STBXSP3020	QTY10 SHD KIT SIZE 2 WIRE CLAMP (for fastening analog and counting modules connection cables)

Each kit includes the following components:

- one grounding bar
- side brackets
- one set of spring locking clamp rings to fasten the cables to the protection bar

The following figure shows a grounding bar fastened to DIN rail Hook:

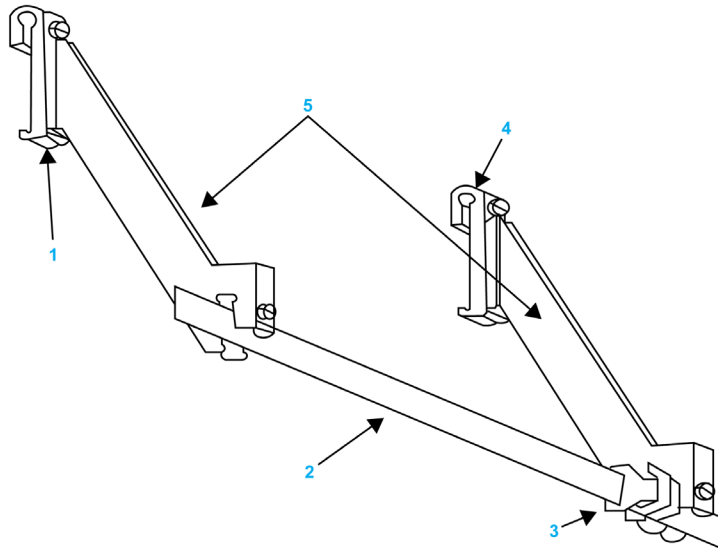

- 1 DIN rail Hook
- 2 Grounding bar
- 3 FG grounding clamp
- 4 DIN rail Hook
- 5 Side brackets

Chapter 11

Operating Standards and Conditions

What Is in This Chapter?

This chapter contains the following topics:

Topic	Page
Standards and Certifications	82
Operating Conditions	83

Standards and Certifications

Description

The Modicon MC80 PLCs are designed to comply with the relevant standards or rules related to an electrical equipment as PLCs for the industrial use.

Standards and Certifications

Introduction

MC80 PLCs have been designed to comply with the relevant standards and rules for electrical equipment in an industrial automation environment.

Industrial Standards

Requirements specific to the PAC functional characteristics, immunity, robustness, and security:

- IEC/EN 61131-2 Ed 3, completed by IEC 61010-2-201
- CSA-E 1131-2
- UL 61010-2-201

European directives for EC Marking:

- low voltage: 2006/95/EC
- electromagnetic compatibility: 2004/108/EC

Installation in Classified Ex Area

- Hazardous locations class I, division 2, groups A, B, C, and D according to CSA 22.2 No.213

Specific Countries

- For Australia and New Zealand: ACMA requirements for RCM marking

DANGER

HAZARD OF ELECTRIC SHOCK, EXPLOSION

Disconnect all power before removing components, if installed in a hazardous location where flammable gases or combustible dusts may be present. Electrical sparks in a hazardous location will cause an explosion.

Failure to follow these instructions will result in death or serious injury.

Operating Conditions

Operating Temperature/Hygrometry/Altitude

These are the operating conditions relative to the outside environment:

Characteristic		Value
Temperature	Operating	-25...70 °C
	Storage	-40...85 °C
Humidity		Max. 93% (non-condensing) at 70 °C
Altitude		<ul style="list-style-type: none">● 0...2,000 m: full specification for temperature and isolation● 2,000...5,000 m:<ul style="list-style-type: none">○ temperature de-rating: -1 °C/400 m○ isolation loss: -150 Vdc/1,000 m

Part III

MC80 Software Implementation

What Is in This Part?

This part contains the following chapters:

Chapter	Chapter Name	Page
12	Configuration of MC80	87
13	MC80 Firmware Upgrade	151

Chapter 12

Configuration of MC80

What Is in This Chapter?

This chapter contains the following topics:

Topic	Page
Configuration of Modicon MC80 Processors	88
Connecting to MC80	91
IO Configuration	92
Configuring the Serial Port of the CPU	111
Modbus Serial communication	114
Character Mode Communication	119
Configuring the Ethernet Port of the CPU	123
CANopen Configuration	132
System Bits and Words	141

Configuration of Modicon MC80 Processors

Enable MC80

The following table describes the steps to enable MC80 in Unity Pro 8.1 or later:

Step	Action
1	Install Unity 8.1 or later.
2	Install the Hot fix: UnityPro_V81_HF_MC80
3	Create a new project with MC80.

Access to the Configuration Screen

The following table describes the steps to access the configuration screen:

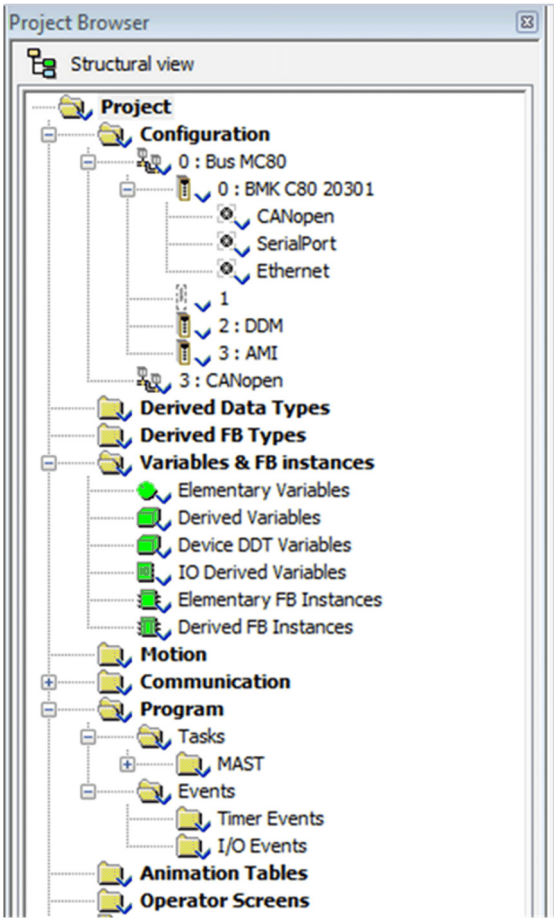
Step	Action
1	Select the processor. 
2	Using the contextual menu, click Open .
3	Select the Configuration tab.

Configuration of the Processor

NOTE: You can modify the parameters of this dialog box only in offline mode.

The following screen shows the MC80 CPU configuration screen:

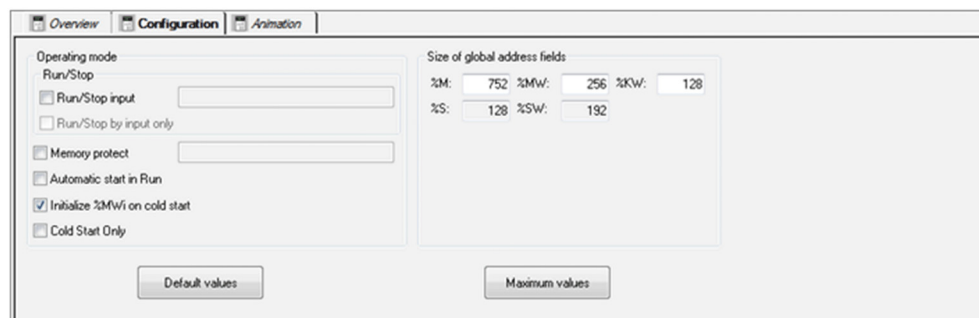

⚠ CAUTION

LOSS OF DATA ON APPLICATION TRANSFER

Press the RESET button on the power supply. Otherwise, %MWi is reset and initial values are loaded.

Failure to follow these instructions can result in injury or equipment damage.

In the configuration screen, proceed with the following steps:

Step	Action
1	Enable the Run/Stop input option, if required. Do not enable this option if the associated discrete input is mapped because this inhibits the PLC start-up.
2	Enable the Memory protect option, if required. The protection is activated by an input bit. It prohibits the transfer of a project into the PLC and modifications in online mode, regardless of the communication channel. The Run and Stop commands are authorized.
3	Enable the Automatic start in Run option, if required.
4	Confirm whether the internal words %MWi are to be initialized on cold start triggered by software (application download, initialize command, restore command, %S0 activation, cold start button on the PLC screen) or not. By checking the box, the PLC writes the initial values to %MWi.
5	Enable the Cold Start Only option, if required.
6	In the Size of global address fields of the dialog box define for the application the number of internal bits %M.
7	Define the number of internal words %MW.
8	Define the number of constants %KW.

The following table shows the different elements of configuration screen and their functions:

Element	Function	
Operating mode		
Operating mode	<p>Operating mode zone includes the following elements:</p> <ul style="list-style-type: none"> ● Run/Stop input ● Memory protect ● Automatic start in Run ● Initialize %MWi on cold start ● Cold Start Only 	
Run/Stop	<p>Run/Stop input can be:</p> <ul style="list-style-type: none"> ● the image value of a physical digital input: MOD_DIS_16_1.DIS_CH_IN[i].VALUE, where i = number from 0...7 ● an unlocated variable of type BOOL with correct RW Program (for example, MyRunStop1) ● an unlocated variable of type EBOOL with correct RW Program (for example, MyRunStop2) <p>The Run/Stop by input only parameter is significant only if the Run/Stop input is valid.</p>	
	<p>If the Run/Stop by input only is unchecked</p>	<p>it is possible to change the PLC state from Run to Stop (or the opposite) either with a Run/Stop Request or by changing the value of the Run/Stop input.</p>
	<p>If the Run/Stop by input only is checked</p>	<p>it is only possible to change the PLC state from Run to Stop (or the opposite) by changing the value of the Run/Stop input.</p> <p>NOTE: Before downloading a different application, reset the Run/Stop input to 0 or press the reset button.</p>
Memory protect	<p>Memory protect follows the same rules as Run/Stop input.</p> <p>When you configure and enable memory protect, you cannot change the PLC configuration or application and upload the application.</p>	
Initialize %MWi on cold start	<p>On a cold start or on download if you check the box (default state)</p>	<p>the %MWi are handled like other global variables (initialized to 0 or initial value, according to current application) in all cold start cases.</p>
	<p>On cold start or on download if you uncheck the box</p>	<p>if %MW were previously saved in internal flash memory (using the %SW96 word) they are restored from internal flash memory</p> <p>if not,</p> <ul style="list-style-type: none"> ● if cold start is linked to a push on the reset button, the %MW are initialized. ● if not, the current values of %MW are maintained.
	<p>NOTE: if the new (or restored) application has more %MW than the previous one, the added %MW are set to 0 (non-zero initial values are not applied).</p>	
Cold Start Only	<p>If checked, this option forces the cold start of the application, instead of the normal warm start. By default, the Cold Start Only option is unchecked.</p> <p>An application using this functionality is not:</p> <ul style="list-style-type: none"> ● downloadable on a PLC with a previous version, ● executable on a PLC with a previous version. <p>If cold start only is checked and run/stop is configured on unlocated variable, then the PLC will restart in run or stop, depending on an initial value of the variable. It does not restart in the same state as before.</p>	
Memory Management		
Memory Management	<p>It includes the Size of global address fields (%M, %MW, %KW, %S, %SW)</p>	

 CAUTION
<p>UNINTENDED EQUIPMENT OPERATION</p> <p>At the end of download, the PLC starts automatically if the default value of a user-defined unlocated Run/Stop variable is 1.</p> <p>Failure to follow these instructions can result in injury or equipment damage.</p>

Connecting to MC80

Description

MC80 is password protected to avoid unwanted application modification and download. A password is required to open the application and connect to MC80.

Creating a Password

Follow the steps below for creating the password:

Step	Action
1	In the project browser, right-click Project .
2	Select Properties command from the pop-up menu. Result: The Properties of Project window appears.
3	Select Protection tab.
4	In the Application field, click Change password Result: The Modify Password window appears.
5	Enter the new password in the Entry field.
6	Enter the confirmation of the new password in the Confirmation field.
7	Click OK to confirm.
8	Click OK or Apply in the Properties of Project window to confirm all changes. If you click Cancel in the Properties of Project window, all changes are canceled.

NOTE: You should enter the password to open the application and connect to MC80.

IO Configuration

Digital IO Function Channels

The various available screens for the discrete functions are:

- Configuration screen
- Type

The following screen shows MC80 Digital IO 8 Input 8 Output functions configuration screen:

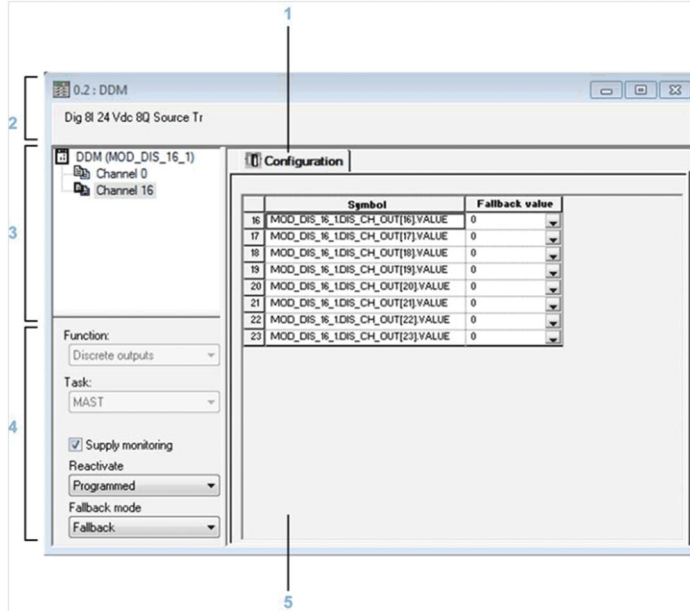

The following screen shows MC80 Digital IO 8 Input 12 Output functions configuration screen:

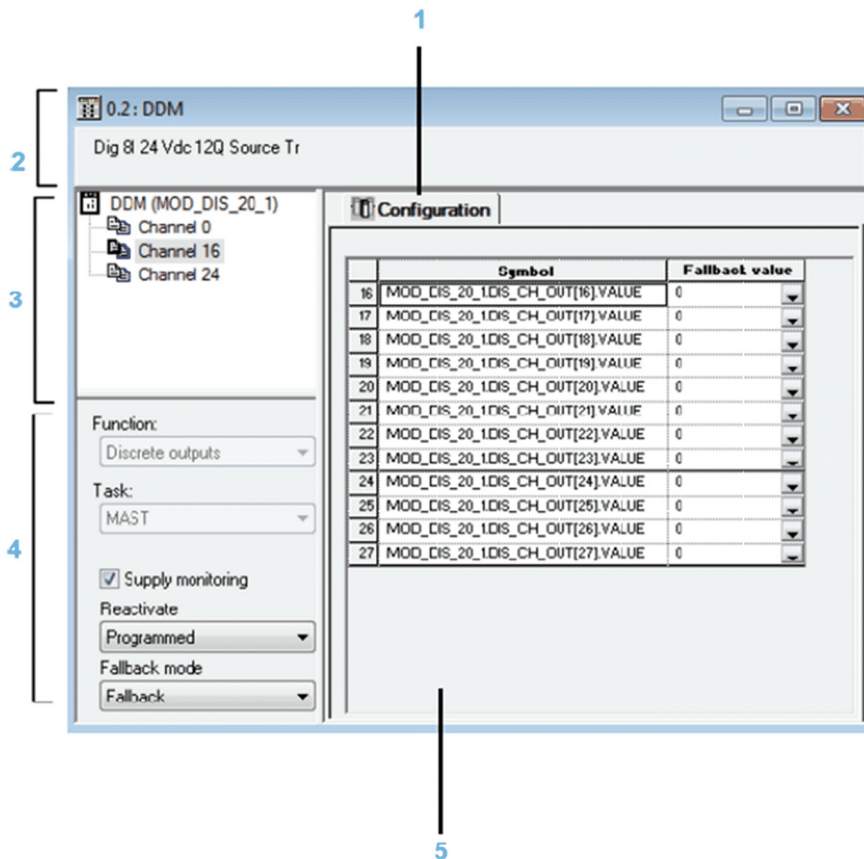

The following table shows the various elements of the configuration screen and their functions:

Address	Element	Function
1	Tabs	The tab in the foreground indicates the mode in progress (Configuration in this example). Every mode can be selected using the respective tab: <ul style="list-style-type: none"> ● Overview ● Configuration ● Device DDT which gives the Device DDT name and type of the device
2	Module area	Specifies the abbreviated heading of the module.
3	Channel area	Allows you: <ul style="list-style-type: none"> ● to click the reference number, to display the tabs: <ul style="list-style-type: none"> ○ Description which gives the characteristics of the device ● to select a channel ● to display the Symbol, name of the channel defined by the user (using the variable editor) <p>NOTE: All channels are activated and a channel cannot be de-activated to None.</p>
4	General parameters area	Allows you to select the associated function and task in groups of 8 channels: <ul style="list-style-type: none"> ● Function: Defines the configuration/de-configuration of the channel group selected (other than groups 0...7) ● Task: Defines the task (MAST) in which channel default exchange objects will be exchanged <p>The Supply monitoring check box defines the active or inactive state of the external power supply monitoring.</p> <p>The Reactivate and Fallback mode drop-down menus enable you to configure the output reset and output fallback mode.</p>
5	Configuration area	Enables the configuration of parameters for the various channels. This field includes various items, displayed according to the selected discrete module.
		The Symbol column displays the symbol associated with the channel.

Task Parameter

This parameter defines the processor task MAST where input acquisitions and output updates are performed.

External Power Supply Error Monitoring Parameter

The following table shows how to disable or enable the external power **Supply monitoring** function:

Step	Action
1	Open the desired module configuration screen.
2	Check the Supply monitoring check box in the General Parameters area. Result : The I/O editor window appears. Click OK .
3	Validate the change by clicking Edit → Validate .

NOTE: The external power supply monitoring function is not available for channel 0...7.

Fallback Mode Parameter

The fallback modes are as follows:

Mode	Meaning
Fallback	Channels are set to 0 or 1 according to the defined fallback value for the corresponding 8-channel group.
Maintain	The outputs remain in the status they were in before switching to Stop .

The following table shows the procedure for defining the fallback mode to be assigned to a channel group.

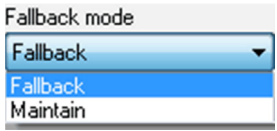
Step	Action
1	Open the desired module configuration screen.
2	For the desired channel group, click the arrow of the Fallback mode drop-down menu. Result : The following list appears 
3	Select the desired fallback mode.
4	For Fallback mode, configure each channel of the selected group. To do this, click the drop-down menu arrow of the channel to be configured, located in the Fall Back Value column.
5	Click the desired value (0 or 1).
6	Confirm the modification with the Edit → Validate menu command.

Output Reset Parameter

The reactivate mode is as follows:

Mode	Meaning
Programmed	Reactivation is executed with a command from the PLC application or through the appropriate debug screen. Remark : In order to avoid repeated reactivations, the module implements an automatic 10 s delay between two resets.
Automatic	The reactivation is executed automatically every 10 s until the error disappears.

The following table shows the procedure for defining the module output channel reset mode.

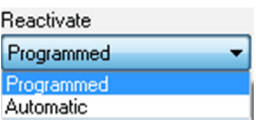
Step	Action
1	Open the desired module configuration screen.
2	For the desired channel group, click the arrow of the Reactivate drop-down menu. Result : The following list appears. 
3	Select the required reactivate mode.
4	Validate the modification by clicking Edit → Confirm .

NOTE: The MC80 IO function does not support the capability to unconfigure channels as the NONE function.

Digital I/O Device DDT

Discrete I/O supplies Device DDT (MDI_DIS_DDDT) for application usage.

The following table shows the Device DDT T_MC80_DIS_STD_IN_8_OUT_8

Standard Symbol	Type	bit #	Meaning	Access
MOD_HEALTH	BOOL	-	0 = the module has a detected error 1 = the module is operating correctly	Read
MOD_FLT	BYTE	-	Internal detected errors bytes of the module	Read
DIS_CH_IN[0...7]	T_MC80_DIS_STD_CH_IN	-	Array [0...7] of T_MC80_DIS_STD_CH_IN	-
DIS_CH_OUT[16...23]	T_MC80_DIS_STD_CH_OUT	-	Array [16...23] of T_MC80_DIS_STD_CH_OUT	-

The following table shows the Device DDT T_MC80_DIS_STD_IN_8_OUT_12

Standard Symbol	Type	bit #	Meaning	Access
MOD_HEALTH	BOOL	-	0 = the module has a detected error 1 = the module is operating correctly	Read
MOD_FLT	BYTE	-	Internal detected errors bytes of the module	Read
DIS_CH_IN[0...7]	T_MC80_DIS_STD_CH_IN	-	Array [0...7] of T_MC80_DIS_STD_CH_IN	-
DIS_CH_OUT[16...27]	T_MC80_DIS_STD_CH_OUT	-	Array [16...27] of T_MC80_DIS_STD_CH_OUT	-

The following table shows the T_MC80_DIS_STD_CH_IN structure meaning:

Standard Symbol	Type	bit #	Meaning	Access
CH_HEALTH	BOOL	-	0 = the channel is inactive, including input power supply lose, input power supply under voltage, or over temperature 1 = the channel is active	Read
VALUE	EBOOL		indicates the status of the sensor controlling the input channel	Read

The following table shows the T_MC80_DIS_STD_CH_OUT structure meaning:

Standard Symbol	Type	bit #	Meaning	Access	
CH_HEALTH	BOOL	-	0 = the channel is inactive. 1 = the channel is active	Read	
VALUE	EBOOL	-	indicates the status of the sensor controlling the output channel	Read /Write	
CH_FLT [INT]	EXT_PS_FLT	BOOL	3	Internal detected error: module out of order	Read
	SHORT_CIRCUIT	BOOL	8	External detected error: short-circuit on a channel	Read
REACTIVATION	BOOL	-	Reactivation	Read /Write	

Analog Input Function 4 Channels Inputs

The various available screens for the analog functions are:

- Configuration screen
- Device DDT screen

The below screen shows MC80 Analog Input functions configuration screen:

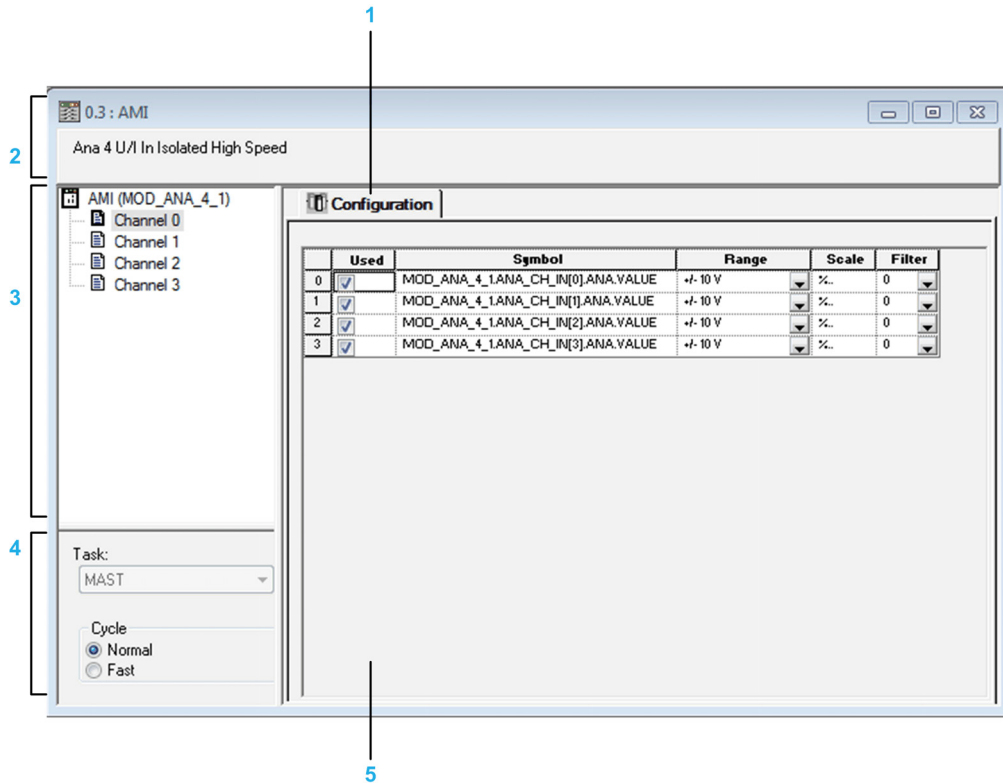

This following table shows the various elements of the configuration screen and their functions:

Address	Element	Function
1	Tabs	The tab in the foreground indicates the mode in progress (Configuration in this example). Every mode can be selected using the respective tab: <ul style="list-style-type: none"> • Overview • Configuration • Device DDT which gives the Device DDT name and type of the device
2	Module area	Specifies the abbreviated heading of the module.
3	Channel area	Allows you: <ul style="list-style-type: none"> • to click the reference number, to display the tabs: <ul style="list-style-type: none"> ○ Description which gives the characteristics of the device • to select a channel • to display the Symbol, name of the channel defined by the user (using the variable editor) <p>NOTE: All channel are activated and a channel cannot be de-activated to None.</p>
4	General parameters area	This is used to set up the channels using several fields: <p>Task: Defines the MAST task through which the exchanges between the processor and the module will be carried out.</p> <p>Cycle: Allows you to define the scan cycle for inputs (only available on some analog modules).</p>
5	Configuration area	This is used to define the configuration parameters of the different channels. This area includes several topics, whose display varies depending on the analog module you've selected. <p>The Symbol column displays the symbol associated with the channel.</p>

For each input, the information related to the following are configurable in the configuration screen associated to the analog input:

- Range
- Scale factor
- Overflow (high and low limits)
- Filtering

Selecting the Range for an Analog Input

This parameter defines the range for the input channel. Depending on the type of function, the input range may be:

- Voltage
- Current

The following table describes the procedure to define the type of task assigned to an analog function's channels:

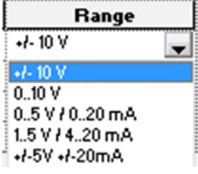
Step	Action
1	Access the hardware configuration screen for the appropriate module
2	In the Range column, click the arrow of the drop-down menu pertaining to the channel you need to configure. Result : The following list appears
	
3	Select the appropriate range.
4	Validate the change by clicking Edit → Validate .

Task Parameter

This parameter defines the processor task MAST where input acquisitions and output updates are performed.

Selecting the Display Format for a Current or Voltage Input Channel

This parameter defines the display format for the measurement of an analog module channel whose range is configured for voltage or current.

The display format may be:

- standardized (%..):
 - unipolar range: 0...+10,000
 - bipolar range : -10,000...+10,000
- user-defined (User).

The following table provides the instructions defining the display scale assigned to an analog module channel:

Step	Action
1	Access the hardware configuration screen for the appropriate module.
2	Click the cell of the Scale column for the channel you need to configure. Result : An arrow appears.

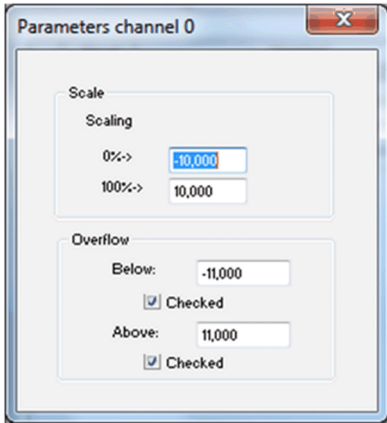
Step	Action
3	<p>Click the arrow in the cell of the Scale column for the channel you need to configure. Result: The Channel Parameters dialog box appears.</p>  <p>NOTE: The display modification change only concerns the Scale area. The Overflow area enables the modification of the overflow control.</p>
4	Type in the values to be assigned to the channel in the two Display boxes situated in the Scale zone.
5	<p>Confirm your changes by closing the dialog box.</p> <p>NOTE: If default values have been selected (standardized display), the corresponding cell in the Scale column displays %... Otherwise it will show User (user display).</p>
6	Validate the change by clicking Edit → Validate .

Selecting the Input Channels Filter Value

This parameter defines the type of filtering for the input channel selected for analog function.

The available filtering values are:

- 0: No filtering
- 1 and 2: Low filtering
- 3 and 4: Medium filtering
- 5 and 6: High filtering

NOTE: Filtering is taken into account in both fast scan and normal cycles.

The following table provides instructions for defining the filter value assigned to input channels for analog function.

Step	Action
1	Access the hardware configuration screen for the appropriate module.
2	<p>In the Filter column, click the arrow of the drop-down menu pertaining to the channel you need to configure. Result : The drop-down menu appears.</p> 
3	Select the filter value you need to assign to the selected channel.
4	Validate the change by clicking Edit → Validate .

Analog Inputs Device DDT

Analog input supplies Device DDT (T_MC80_ANA_STD_IN_4) for application usage.

The following table shows the T_MC80_ANA_STD_IN_4:

Standard Symbol	Type	Bit #	Meaning	Access
MOD_HEALTH	BOOL	-	0 = the module has a detected error	Read
		-	1 = the module is operating correctly	
MOD_FLT	BYTE	-	Internal detected errors bytes of the module	Read
ANA_CH_IN[0...3]	T_MC80_ANA_STD_CH_IN	-	Array of structure	-

The following table shows the T_MC80_ANA_STD_CH_IN structure meaning:

Standard Symbol	Type	Bit #	Meaning	Access	
FCT_TYPE	WORD	-	0 = channel is not used 1 = channel is used	Read	
CH_HEALTH	BOOL	-	0 = the channel is inactive 1 = the channel is active	Read	
CH_WARNING	BOOL	-	0 = no detected warning on the channel 1 = detected warning on the channel	Read	
ANA	T_MC80_ANA_VALUE_IN	-	Analog input structure	-	
MEASURE_STS [INT]	CH_ALIGNED	BOOL	0	Aligned channel	Read
	LOWER_LIMIT	BOOL	5	Measurement within lower tolerance zone	Read
	UPPER_LIMIT	BOOL	6	Measurement within upper tolerance zone	Read
	INT_OFFSET_ERROR	BOOL	8	Internal offset error	Read
	IN_REF_ERROR	BOOL	10	Internal reference error	Read
	POWER_COM_ERROR	BOOL	11	Power supply error	Read
	SPI_COM_ERROR	BOOL	12	SPI communication error	Read
CH_FLT [INT]	SENSOR_FLT	BOOL	0	External fault: sensor link fault	Read
	RANGE_UNF	BOOL	1	External fault: Range under fault	Read
	RANGE_OVF	BOOL	2	External fault: Range overrun fault	Read
	EXTERNAL_FLT	BOOL	3	External fault: channel error report	Read
	INTERNAL_FLT	BOOL	4	Internal fault: channel inoperative	Read
	CONF_FLT	BOOL	5	Hardware or software configuration fault	Read
	COM_FLT	BOOL	6	Bus communication fault	Read
	APPLI_FLT	BOOL	7	Application fault	Read
	NOT_READY	BOOL	8	Channel not ready	Read
CALIB_FLT	BOOL	9	Calibration fault	Read	
ALIGNMENT_CURRENT_VALUE	INT	-	Current value of alignment	Read	
FILTER_CURRENT_VALUE	INT	-	Current value of filter	Read	
ALIGNMENT_PRESET_VALUE	INT	-	Preset value of alignment	Write	
FILTER_PRESET_VALUE	INT	-	Present value of filter (0...6)	Write	
CMD_ALIGNMENT	BOOL	-	Rising edge: execute command to change alignment with the preset alignment value	Write	
CMD_FILTER	BOOL	-	Rising edge: execute command to change filter with the preset filter value	Write	

The following table shows the T_MC80_ANA_VALUE_IN structure meaning:

Standard Symbol	Type	Bit #	Meaning	Access
VALUE	INT	-	Analog input value	Read
FORCED_VALUE	INT	-	Forced value	Read/Write
FORCE_CMD	BOOL	-	Force command	Read/Write
FORCED_STATE	BOOL	-	Forced state	Read
TRUE_VALUE	INT	-	Physical value	Read

High Speed Generic Counter

The following figure shows the counting modules configuration screen.

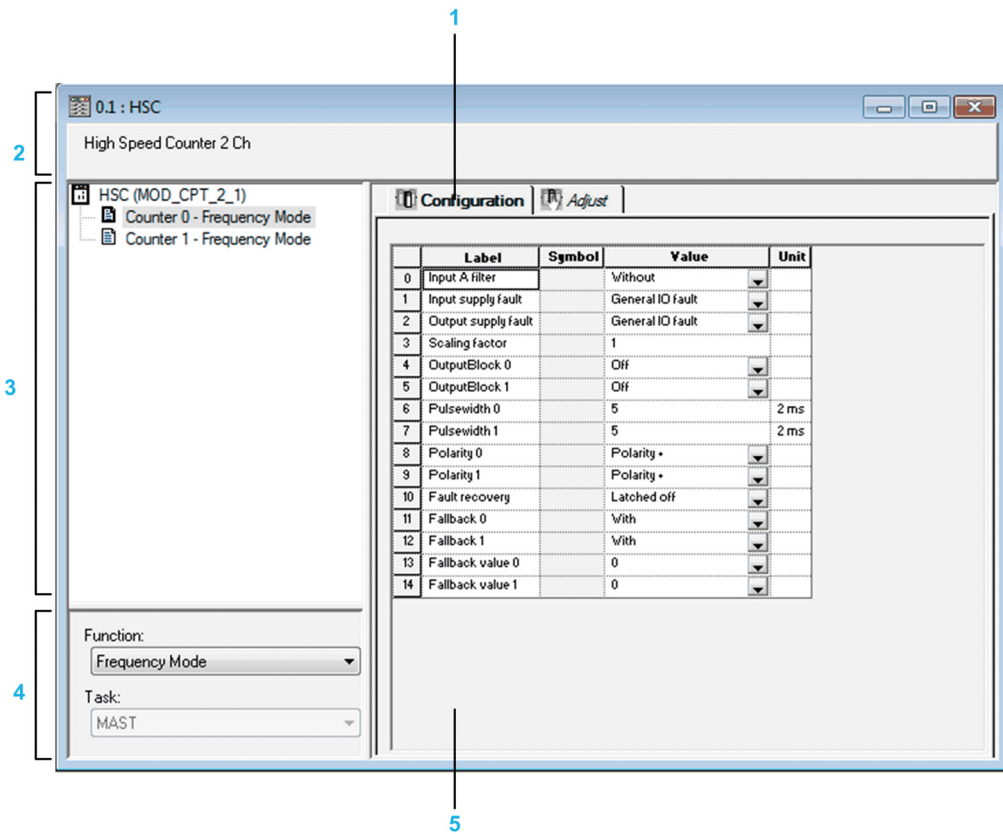

The following table describes the parts of the various screens:

Address	Element	Function
1	Tabs	The tab in the foreground indicates the mode in progress (Configuration in this example). Every mode can be selected using the respective tab: <ul style="list-style-type: none"> ● Configuration
2	Module area	Displays the name and status of a function. Is used: <ul style="list-style-type: none"> ● To click the reference number, to display the tabs: <ul style="list-style-type: none"> ○ Device DDT
3	Channel area	Allows you: <ul style="list-style-type: none"> ● to click the reference number, to display the tabs: <ul style="list-style-type: none"> ○ Description which gives the characteristics of the device ● to select a channel ● to display the Symbol, name of the channel defined by the user (using the variable editor) <p>NOTE: All channels are activated and a channel cannot be de-activated to None.</p>
4	General parameters area	Allows you to select the counting function and the task associated with the channel: Function: Counting function among those available for the modules involved. Depending on this choice, the headings of the configuration area may differ. By default, in Frequency Mode no function is configured. Task: defines the MAST task through which the channel's implicit exchange objects will be exchanged. These choices are only possible in offline mode. NOTE: In Configuration view, the events are not managed.
5	Parameters in progress area	This area has various functionalities which depend upon the current mode: Configuration: It is used to configure the channel parameters. NOTE: The Input and Output fault parameters are set by default with the value Local or General IO Fault.

Frequency Mode Configuration

The following table describes the frequency mode configurable elements:

Label	Configurable Values
IN_A input filter	The least significant byte can take the following values: 0: Without, 1: low, 2: medium, 3: high.
Input power supply fault	0:General input fault mode 1:Local input fault mode
Output power supply fault	0:General output fault mode 1:Local output fault mode
Scale factor	Edit (value in the range 1...255)
Output block 0	This parameter can take the following values: 0: Off, 1: Low counter, 2: Counter in a window, 3: High counter, 4: Pulse = less than the lower threshold (LT), 5: Pulse = greater than the lower threshold (LT), 6: Pulse = less than the upper threshold (UT), 7: Pulse = greater than the upper threshold (UT).
Output block 1	This parameter can take the following values: 0: Off, 1: Low counter, 2: Counter in a window, 3: High counter, 4: Pulse = less than the lower threshold (LT), 5: Pulse = greater than the lower threshold (LT), 6: Pulse = less than the upper threshold (UT), 7: Pulse = greater than the upper threshold (UT).
Pulse width 0	Are a number of 2 ms in a range 1...32,767 (Even value from 2 ms to 65,534 ms)
Pulse width 1	Are a number of 2 ms in a range 1...32,767 (Even value from 2 ms to 65,534 ms)
Polarity 0	0:Polarity + 1:Polarity -
Polarity 1	0:Polarity + 1:Polarity -
Fault recovery	Automatic reaction Activated
Fallback 0	0:Without 1:With
Fallback 1	0:Without 1:With
Fallback value 0	0 1
Fallback value 1	0 1

Event Counting Mode Configuration

The following table describes the event counting mode configurable elements:

Label	Configurable Values
IN_A input filter	The least significant byte can take the following values: 0: Without, 1: Low, 2: Medium, 3: High.
IN_SYNC input filter	The least significant byte can take the following values: 0: Without, 1: Low, 2: Medium, 3: High.
Input power supply fault	0:General input fault mode 1:Local input fault mode
Output power supply fault	0:General output fault mode 1:Local output fault mode
Synchronization edge	0:Rising edge at IN_SYNC 1:Falling edge at IN_SYNC
Time base	This parameter can take the following values: 0: 0.1 s, 1: 1 s, 2: 10 s, 3: 1 min.
Output block 0	This parameter can take the following values: 0: Off, 1: Low counter, 2: Counter in a window, 3: High counter, 4: Pulse = less than the lower threshold (LT), 5: Pulse = greater than the lower threshold (LT), 6: Pulse = less than the upper threshold (UT), 7: Pulse = greater than the upper threshold (UT).
Output block 1	This parameter can take the following values: 0: Off, 1: Low counter, 2: Counter in a window, 3: High counter, 4: Pulse = less than the lower threshold (LT), 5: Pulse = greater than the lower threshold (LT), 6: Pulse = less than the upper threshold (UT), 7: Pulse = greater than the upper threshold (UT).
Pulse width 0	Are a number of 2 ms in a range 1...32,767 (Even value from 2 ms to 65,534 ms)
Pulse width 1	Are a number of 2 ms in a range 1...32,767 (Even value from 2 ms to 65,534 ms)
Polarity 0	0:Polarity + 1:Polarity -
Polarity 1	0:Polarity + 1:Polarity -
Fault recovery	Automatic reaction Activated
Fallback 0	0:Without 1:With
Fallback 1	0:Without 1:With
Fallback value 0	0 1
Fallback value 1	0 1

Period Measuring Mode Configuration

The following table describes the period measuring mode configurable elements:

Label	Configurable Values
IN_A input filter	The least significant byte can take the following values: 0: Without, 1: Low, 2: Medium, 3: High.
IN_SYNC input filter	The least significant byte can take the following values: 0: Without, 1: Low, 2: Medium, 3: High.
Input power supply fault	0:General input fault mode 1:Local input fault mode
Output power supply fault	0:General output fault mode 1:Local output fault mode
Resolution	This parameter can take the following values : 0: 1 μ s, 1: 100 μ s, 2: 1 ms.
Mode	This parameter can take the following values : 0: From one edge to the same edge at input IN_A, 1: From one edge to the opposite edge at input IN_A.
Time out	1... 1073741823
Output block 0	This parameter can take the following values: 0: Off, 1: Low counter, 2: Counter in a window, 3: High counter, 4: Pulse = less than the lower threshold (LT), 5: Pulse = greater than the lower threshold (LT), 6: Pulse = less than the upper threshold (UT), 7: Pulse = greater than the upper threshold (UT).
Output block 1	This parameter can take the following values: 0: Off, 1: Low counter, 2: Counter in a window, 3: High counter, 4: Pulse = less than the lower threshold (LT), 5: Pulse = greater than the lower threshold (LT), 6: Pulse = less than the upper threshold (UT), 7: Pulse = greater than the upper threshold (UT).
Pulse width 0	Are a number of 2 ms in a range 1...32,767 (Even value from 2 ms to 65,534 ms)
Pulse width 1	Are a number of 2 ms in a range 1...32,767 (Even value from 2 ms to 65,534 ms)
Polarity 0	0:Polarity + 1:Polarity -
Polarity 1	0:Polarity + 1:Polarity -
Fault recovery	Automatic reaction Activated
Fallback 0	0:Without 1:With
Fallback 1	0:Without 1:With
Fallback value 0	0 1
Fallback value 1	0 1

Ratio Mode Configuration

The following table describes the ratio mode configurable elements:

Label	Configurable Values
IN_A input filter	The least significant byte can take the following values: 0: Without, 1: Low, 2: Medium, 3: High.
IN_B input filter	The least significant byte can take the following values: 0: Without, 1: Low, 2: Medium, 3: High.
Input power supply fault	0:General input fault mode 1:Local input fault mode
Output power supply fault	0:General output fault mode 1:Local output fault mode
Absolute limit	Edit
Output block 0	This parameter can take the following values: 0: Off, 1: Low counter, 2: Counter in a window, 3: High counter, 4: Pulse = less than the lower threshold (LT), 5: Pulse = greater than the lower threshold (LT), 6: Pulse = less than the upper threshold (UT), 7: Pulse = greater than the upper threshold (UT).
Output block 1	This parameter can take the following values: 0: Off, 1: Low counter, 2: Counter in a window, 3: High counter, 4: Pulse = less than the lower threshold (LT), 5: Pulse = greater than the lower threshold (LT), 6: Pulse = less than the upper threshold (UT), 7: Pulse = greater than the upper threshold (UT).
Pulse width 0	Are a number of 2 ms in a range 1...32,767 (Even value from 2 ms to 65,534 ms)
Pulse width 1	Are a number of 2 ms in a range 1...32,767 (Even value from 2 ms to 65,534 ms)
Polarity 0	0:Polarity + 1:Polarity -
Polarity 1	0:Polarity + 1:Polarity -
Fault recovery	Automatic reaction Activated
Fallback 0	0:Without 1:With
Fallback 1	0:Without 1:With
Fallback value 0	0 1
Fallback value 1	0 1

One Shot Counter Mode Configuration

The following table describes the one shot counter mode configurable elements:

Label	Configurable Values
IN_A input filter	The least significant byte can take the following values: 0: Without, 1: Low, 2: Medium, 3: High.
IN_SYNC input filter	The least significant byte can take the following values: 0: Without, 1: Low, 2: Medium, 3: High.
IN_EN input filter	The least significant byte can take the following values: 0: Without, 1: Low, 2: Medium, 3: High.
Input power supply fault	0:General input fault mode 1:Local input fault mode
Output power supply fault	0:General output fault mode 1:Local output fault mode
Scale factor	Edit (value in the range 1...255)
Synchronization edge	0:Rising edge at IN_SYNC 1:Falling edge at IN_SYNC
Output block 0	This parameter can take the following values: 0: Off, 1: Low counter, 2: Counter in a window, 3: High counter, 4: Pulse = less than the lower threshold (LT), 5: Pulse = greater than the lower threshold (LT), 6: Pulse = less than the upper threshold (UT), 7: Pulse = greater than the upper threshold (UT). 8: Counter Stop 9: Counter Run
Output block 1	This parameter can take the following values: 0: Off, 1: Low counter, 2: Counter in a window, 3: High counter, 4: Pulse = less than the lower threshold (LT), 5: Pulse = greater than the lower threshold (LT), 6: Pulse = less than the upper threshold (UT), 7: Pulse = greater than the upper threshold (UT). 8: Counter Stop 9: Counter Run
Pulse width 0	Are a number of 2 ms in a range 1...32,767 (Even value from 2 ms to 65,534 ms)
Pulse width 1	Are a number of 2 ms in a range 1...32,767 (Even value from 2 ms to 65,534 ms)
Polarity 0	0:Polarity + 1:Polarity -
Polarity 1	0:Polarity + 1:Polarity -
Fault recovery	Automatic reaction Activated
Fallback 0	0:Without 1:With
Fallback 1	0:Without 1:With
Fallback value 0	0 1
Fallback value 1	0 1

Modulo Loop Counter Mode Configuration

The following table describes the modulo loop counter mode configurable elements:

Label	Configurable Values
IN_A input filter	The least significant byte can take the following values: 0: Without, 1: Low, 2: Medium, 3: High.
IN_B input filter	The least significant byte can take the following values: 0: Without, 1: Low, 2: Medium, 3: High.
IN_SYNC input filter	The least significant byte can take the following values: 0: Without, 1: Low, 2: Medium, 3: High.
IN_EN input filter	The least significant byte can take the following values: 0: Without, 1: Low, 2: Medium, 3: High.
Input power supply fault	0:General input fault mode 1:Local input fault mode
Output power supply fault	0:General output fault mode 1:Local output fault mode
Interface mode	0: A = High, B = Low, 1: A = Pulse, B = Direction, 2: normal quadrature 1, 3: normal quadrature 2, 4: normal quadrature 4, 5: inverse quadrature 1, 6: inverse quadrature 2, 7: inverse quadrature 4.
Scale factor	Edit (value in the range 1...255)
Synchronization edge	0:Rising edge at IN_SYNC 1:Falling edge at IN_SYNC
Output block 0	This parameter can take the following values: 0: Off, 1: Low counter, 2: Counter in a window, 3: High counter, 4: Pulse = less than the lower threshold (LT), 5: Pulse = greater than the lower threshold (LT), 6: Pulse = less than the upper threshold (UT), 7: Pulse = greater than the upper threshold (UT). 10: Capture0 Low Out is High level if Capture value < LT 11: Capture0 In window Out is High level if LT ≤ capture value ≤ UT 12: Capture0 High Out is High level if LT ≤ capture value ≤ UT
Output block 1	This parameter can take the following values: 0: Off, 1: Low counter, 2: Counter in a window, 3: High counter, 4: Pulse = less than the lower threshold (LT), 5: Pulse = greater than the lower threshold (LT), 6: Pulse = less than the upper threshold (UT), 7: Pulse = greater than the upper threshold (UT). 10: Capture0 Low Out is High level if Capture value < LT 11: Capture0 In window Out is High level if LT ≤ capture value ≤ UT 12: Capture0 High Out is High level if LT ≤ capture value ≤ UT
Pulse width 0	Are a number of 2 ms in a range 1...32,767 (Even value from 2 ms to 65,534 ms)
Pulse width 1	Are a number of 2 ms in a range 1...32,767 (Even value from 2 ms to 65,534 ms)

Label	Configurable Values
Polarity 0	0:Polarity + 1:Polarity -
Polarity 1	0:Polarity + 1:Polarity -
Fault recovery	Automatic reaction Activated
Fallback 0	0:Without 1:With
Fallback 1	0:Without 1:With
Fallback value 0	0 1
Fallback value 1	0 1

Free Large Counter Mode Configuration

The following table describes the free large counter mode configurable elements:

Label	Configurable Values
IN_A input filter	The least significant byte can take the following values: 0: Without, 1: Low, 2: Medium, 3: High.
IN_B input filter	The least significant byte can take the following values: 0: Without, 1: Low, 2: Medium, 3: High.
IN_SYNC input filter	The least significant byte can take the following values: 0: Without, 1: Low, 2: Medium, 3: High.
IN_EN input filter	The least significant byte can take the following values: 0: Without, 1: Low, 2: Medium, 3: High.
IN_REF input filter	The least significant byte can take the following values: 0: Without, 1: Low, 2: Medium, 3: High.
IN_CAP input filter	The least significant byte can take the following values: 0: Without, 1: Low, 2: Medium, 3: High.
Input power supply fault	0:General input fault mode 1:Local input fault mode
Output power supply fault	0:General output fault mode 1:Local output fault mode
Interface mode	0: A = High, B = Low, 1: A = Pulse, B = Direction, 2: normal quadrature 1, 3: normal quadrature 2, 4: normal quadrature 4, 5: inverse quadrature 1, 6: inverse quadrature 2, 7: inverse quadrature 4.
Scale factor	Edit (value in the range 1...255)

Label	Configurable Values
Preset mode	The least significant byte can take the following values: 0: rising edge at IN_SYNC 1: rising edge at IN_REF 2: rising edge at IN_SYNC and IN_REF 3: first rising edge at IN_SYNC and IN_REF at 1 4: first rising edge at IN_SYNC and IN_REF at 0
Present edge	0:Rising edge at IN_SYNC 1:Falling edge at IN_SYNC
Counter behavior	0:Lock on limits 1:Rollover
Capture 0 settings	0:Preset condition 1:Falling edge at the IN_CAP input
Output block 0	This parameter can take the following values: 0: Off, 1: Low counter, 2: Counter in a window, 3: High counter, 4: Pulse = less than the lower threshold (LT), 5: Pulse = greater than the lower threshold (LT), 6: Pulse = less than the upper threshold (UT), 7: Pulse = greater than the upper threshold (UT). 10: Capture0 Low Out is High level if Capture value < LT 11: Capture0 In window Out is High level if $LT \leq \text{capture value} \leq UT$ 12: Capture0 High Out is High level if $LT \leq \text{capture value} \leq UT$ 13: Capture1 Low Out is High level if Capture value < LT 14 :Capture1 In window Out is High level if $LT \leq \text{capture value} \leq UT$ 15 :Capture1 High Out is High level if $LT \leq \text{capture value} \leq UT$
Output block 1	This parameter can take the following values: 0: Off, 1: Low counter, 2: Counter in a window, 3: High counter, 4: Pulse = less than the lower threshold (LT), 5: Pulse = greater than the lower threshold (LT), 6: Pulse = less than the upper threshold (UT), 7: Pulse = greater than the upper threshold (UT). 10: Capture0 Low Out is High level if Capture value < LT 11: Capture0 In window Out is High level if $LT \leq \text{capture value} \leq UT$ 12: Capture0 High Out is High level if $LT \leq \text{capture value} \leq UT$ 13: Capture1 Low Out is High level if Capture value < LT 14 :Capture1 In window Out is High level if $LT \leq \text{capture value} \leq UT$ 15 :Capture1 High Out is High level if $LT \leq \text{capture value} \leq UT$
Pulse width 0	Are a number of 2 ms in a range 1...32,767 (Even value from 2 ms to 65,534 ms)
Pulse width 1	Are a number of 2 ms in a range 1...32,767 (Even value from 2 ms to 65,534 ms)
Polarity 0	0:Polarity + 1:Polarity -
Polarity 1	0:Polarity + 1:Polarity -
Fault recovery	Automatic reaction Activated
Fallback 0	0:Without 1:With
Fallback 1	0:Without 1:With
Fallback value 0	0 1
Fallback value 1	0 1

HSC Device DDT

HSC supplies Device DDT for application usage.

The following table shows the T_MC80_CPT_STD_IN_2:

Standard Symbol	Type	Meaning	Access
MOD_HEALTH	BOOL	0 = the module has a detected error	Read
		1 = the module is operating correctly	
MOD_FLT	BYTE	Internal detected errors bytes of the module	Read
CPT_CH_IN[0...1]	T_MC80_CPT_STD_CH_IN	Array of structure	-

The following table shows the T_MC80_CPT_STD_CH_IN structure meaning:

Standard Symbol	Type	Bit #	Meaning	Access	
FCT_TYPE	WORD	-	-	-	
CH_HEALTH	BOOL	-	0 = channel is inactive	Read	
			1 = channel is active		
ST_OUTPUT_0_ECHO	EBOOL	-	logical state of output 0	Read	
ST_OUTPUT_1_ECHO	EBOOL	-	logical state of output 1	Read	
ST_OUTPUT_BLOCK_0	EBOOL	-	status of physical counting output block 0	Read	
ST_OUTPUT_BLOCK_1	EBOOL	-	status of physical counting output block 1	Read	
ST_INPUT_A	EBOOL	-	status of physical counting input A	Read	
ST_INPUT_B	EBOOL	-	status of physical counting input B	Read	
ST_INPUT_SYNC	EBOOL	-	physical state of the IN_SYNC input (or IN_AUX)	Read	
ST_INPUT_EN	EBOOL	-	physical state of IN_EN input (enable)	Read	
ST_INPUT_REF	EBOOL	-	physical state of the IN_REF input (preset)	Read	
ST_INPUT_CAPT	EBOOL	-	physical state of IN_CAP input (capture)	Read	
COUNTER_STATUS [INT]	RUN	BOOL	0	the counter operates in counting mode only	Read
	MODULO_FLAG	BOOL	1	flag set to 1 by a modulo switch event	Read
	SYNC_REF_FLAG	BOOL	2	flag set to 1 by a preset or synchronization event	Read
	VALIDITY	BOOL	3	the current numerical value is valid	Read
	HIGH_LIMIT	BOOL	4	the current numerical value is locked at the upper threshold value	Read
COMPARE_STATUS [INT]	LOW_LIMIT	BOOL	5	the current numerical value is locked at the lower threshold value	Read
	COUNTER_LOW	BOOL	0	current counter value less than lower threshold (LOWER_TH_VALUE)	Read
	COUNTER_WIN	BOOL	1	current counter value is between lower threshold (LOWER_TH_VALUE) and upper threshold (UPPER_TH_VALUE)	Read
	COUNTER_HIGH	BOOL	2	current counter value greater than upper threshold (UPPER_TH_VALUE)	Read
	CAPT_0_LOW	BOOL	3	Value captured in register 0 is less than lower threshold (LOWER_TH_VALUE)	Read
	CAPT_0_WIN	BOOL	4	Value captured in register 0 is between lower threshold (LOWER_TH_VALUE) and upper threshold (UPPER_TH_VALUE)	Read
	CAPT_0_HIGH	BOOL	5	Value captured in register 0 is greater than upper threshold (UPPER_TH_VALUE)	Read
	CAPT_1_LOW	BOOL	6	Value captured in register 1 is less than lower threshold (LOWER_TH_VALUE)	Read
CAPT_1_WIN	BOOL	7	Value captured in register 1 is between lower threshold (LOWER_TH_VALUE) and upper threshold (UPPER_TH_VALUE)	Read	
CAPT_1_HIGH	BOOL	8	Value captured in register 1 is greater than upper threshold (UPPER_TH_VALUE)	Read	
COUNTER_CURRENT_VALUE_S	DINT	-	Current counter value during event	Read	
COUNTER_CURRENT_VALUE_US	UDINT	-	Current counter value during event	Read	

Standard Symbol		Type	Bit #	Meaning	Access
CAPT_0_VALUE_S		DINT	-	Value captured in register 0	Read
CAPT_1_VALUE_S		DINT	-	Value captured in register 1	Read
OUTPUT_0		EBOOL	-	forces OUTPUT_0 to level 1	Read / Write
OUTPUT_1		EBOOL	-	forces OUTPUT_1 to level 1	Read / Write
OUTPUT_BLOCK_0_ENABLE		EBOOL	-	implementation of output 0 function block	Read / Write
OUTPUT_BLOCK_1_ENABLE		EBOOL	-	implementation of output 1 function block	Read / Write
FORCE_SYNC		EBOOL	-	counting function synchronization and start, which is valid only on rising edge	Read / Write
FORCE_REF		EBOOL	-	set to preset counter value, which is valid only on rising edge	Read / Write
FORCE_ENABLE		EBOOL	-	implementation of counter, which is valid only on rising edge	Read / Write
FORCE_RESET		EBOOL	-	reset counter, which is valid only on rising edge	Read / Write
SYNC_RESET		EBOOL	-	reset SYNC_REF_FLAG	Read / Write
MODULO_RESET		EBOOL	-	reset MODULO_FLAG	Read / Write
FUNCTIONS_ENABLING [INT]	VALID_SYNC	BOOL	0	synchronization and start authorization for the counting function via the IN_SYNC input	Read / Write
	VALID_REF	BOOL	1	operation authorization for the internal preset function	Read / Write
	VALID_ENABLE	BOOL	2	authorization of the counter enable via the IN_EN input	Read / Write
	VALID_CAPT_0	BOOL	3	capture authorization in the capture 0 register	Read / Write
	VALID_CAPT_1	BOOL	4	capture authorization in the capture 1 register	Read / Write
	COMPARE_ENABLE	BOOL	5	comparators operation authorization	Read / Write
	COMPARE_SUSPEND	BOOL	6	comparator frozen at its last value	Read / Write
CH_FLT(Diagnostic)	EXTERNAL_FLT_INPUTS	BOOL	0	external detected error at inputs	Read
	EXTERNAL_FLT_OUTPUTS	BOOL	1	external detected error at outputs	Read
	INTERNAL_FLT	BOOL	2	internal detected error: channel inoperative	Read
	CONF_FLT	BOOL	3	hardware or software configuration detected error	Read
	SENSOR_SUPPLY	BOOL	4	low input power supply for the sensors	Read
	ACTUATOR_SUPPLY	BOOL	5	output power supply loss	Read
	SHORT_CIRCUIT_OUT_0	BOOL	6	short circuit on output 0	-
	SHORT_CIRCUIT_OUT_1	BOOL	7	short circuit on output 1	Read

Configuring the Serial Port of the CPU

General Properties

The serial links of the CPU support two communication protocols:

- Modbus Serial
- Character Mode

Modbus is a standard protocol with the following properties:

- Establishes client/server communication between different modules within a bus or serial link. The client is identified by the master and the slave modules represent the servers.
- Composes of requests and responses data exchange modes and offers services via function codes.
- Establishes a means of exchanging frames from Modbus applications in two types of code; RTU mode and ASCII mode.

Character mode is a point-to-point mode of data exchange between two entities. It does not establish hierarchically structured serial link communications or offer services via function codes, unlike Modbus protocol. Character Mode is asynchronous.

Each item of textual information is sent or received character by character at irregular time intervals. The time taken by the exchanges can be determined from the following properties:

- One or two end-of-frame characters
- Timeout
- Number of characters

Configuration

Communicating via Serial link enables data exchange between all devices connected to the bus. The Modbus Serial is a protocol that creates a hierarchical structure (one master and several slaves).

The master manages all exchanges in two ways:

- The master exchanges with the slave and awaits a response.
- The master exchanges with all the slaves without waiting for a response (general broadcast).

NOTE: Be careful that two masters (on the same bus) do not send requests simultaneously otherwise the requests are lost and each report will have a bad result which could be 16#0100 (request could not be processed) or 16#ODFF (slave is not present).

The below table describes the procedure for accessing the serial link:

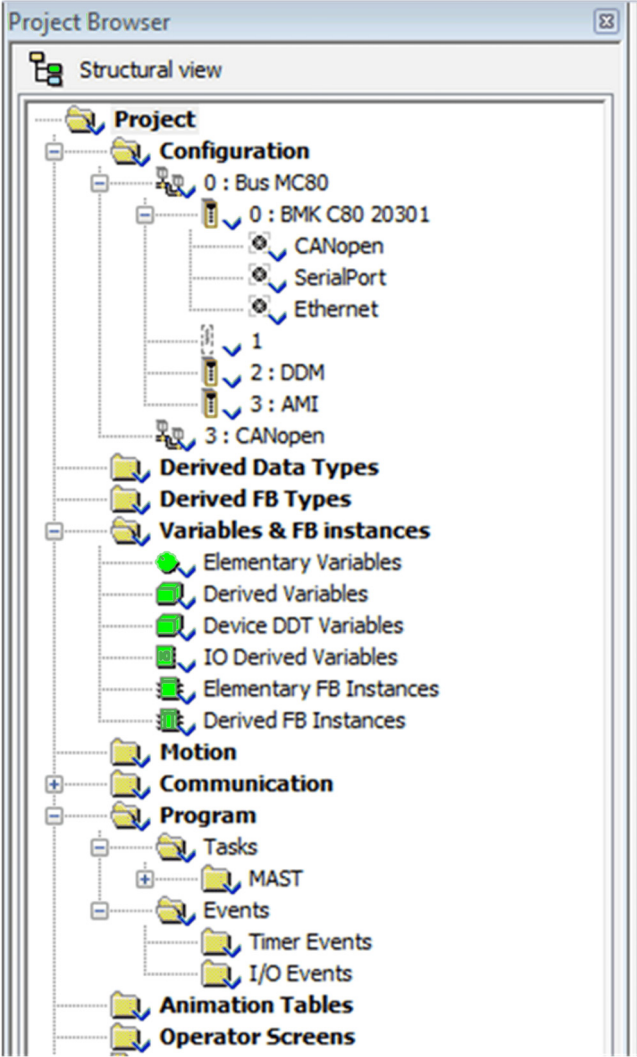
Step	Action
1	<p>In the Project Browser, open the following directory: Station\Configuration\0: Bus MC80\0: processor reference\SerialPort. The following screen appears:</p>  <p>The screenshot shows a 'Project Browser' window with a 'Structural view' of a project. The tree structure is as follows:</p> <ul style="list-style-type: none"> Project <ul style="list-style-type: none"> Configuration <ul style="list-style-type: none"> 0 : Bus MC80 <ul style="list-style-type: none"> 0 : BMK C80 20301 <ul style="list-style-type: none"> CANopen SerialPort Ethernet 1 2 : DDM 3 : AMI 3 : CANopen Derived Data Types Derived FB Types Variables & FB instances <ul style="list-style-type: none"> Elementary Variables Derived Variables Device DDT Variables IO Derived Variables Elementary FB Instances Derived FB Instances Motion Communication Program <ul style="list-style-type: none"> Tasks <ul style="list-style-type: none"> MAST Events <ul style="list-style-type: none"> Timer Events I/O Events Animation Tables Operator Screens
2	<p>Double-click the SerialPort sub-directory. The configuration screen appears.</p>

The following is the configuration screen:

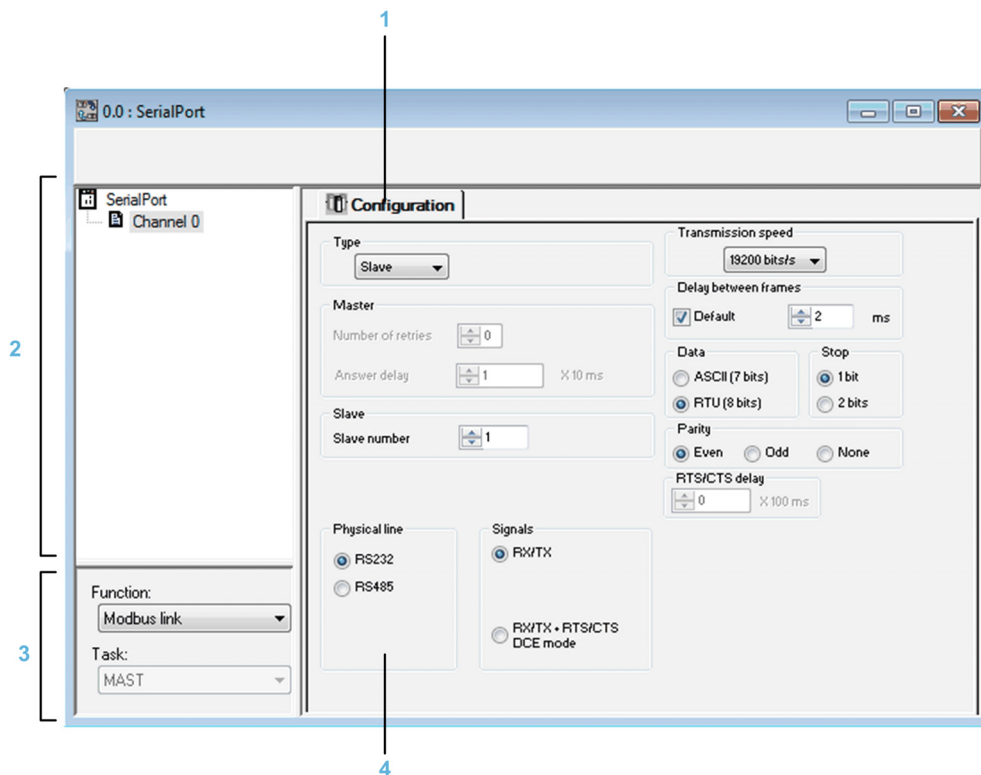

The following table describes the different elements of the configuration screen:

Address	Element	Function
1	Tabs	The tab in foreground indicates the current mode. The mode can be selected using the corresponding tab. The available modes are: <ul style="list-style-type: none"> ● Configuration
2	Channel zone	Enables you to: <ul style="list-style-type: none"> ● Select between the serial port and channel 0 by clicking one or the other. ● Display the following tabs by clicking the SerialPort: <ul style="list-style-type: none"> ○ Description, which gives the characteristics of the device. ● Display the following tabs by clicking the Channel 0: <ul style="list-style-type: none"> ○ Configuration ● Display the channel name and symbol defined by the user using the variables editor.
3	General parameters zone	This enables you to choose the general parameters associated with the channel: <ul style="list-style-type: none"> ● Function: The available functions are Modbus and Character Mode. The default configuration is with the Modbus function. ● Task: Defines the master task in which the implicit exchange objects of the channel will be exchanged. This zone is grayed out and therefore not configurable.
4	Configuration zone	In configuration mode, this zone is used to configure the channel parameters.

Modbus Serial communication

Modbus Serial Communication Configuration Screen

To access the Modbus serial communication configuration screen, open the Serial Port directory in the project browser (*see page 111*).

The figure below shows the default configuration screen for Modbus serial communication:

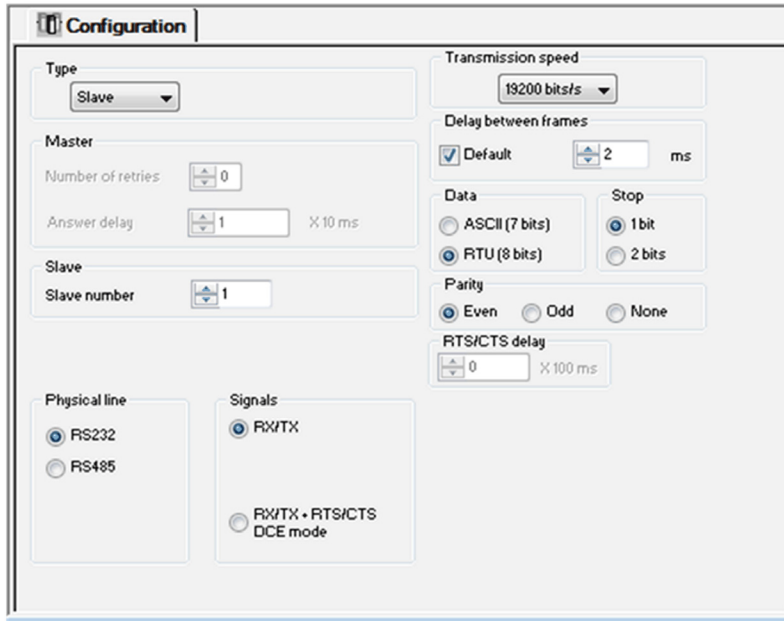

These zones are used to configure channel parameters. In offline mode, these zones are accessible. In online mode, the zone is accessible but some parameters are unavailable.

The following table shows the different zones of the Modbus link configuration screen:

Key	Element	Description
1	Application parameters	These parameters are accessible via 3 zones: <ul style="list-style-type: none"> • Type • Master • Slave
2	Transmission parameters	These parameters are accessible via 5 zones: <ul style="list-style-type: none"> • Transmission speed • Delay between frames • Data • Stop bits • Parity
3	Signal and physical line parameters	These parameters are accessible via 3 zones: <ul style="list-style-type: none"> • Physical line • Signals • RTS/CTS delay

NOTE: When configuring Modbus Serial communication in Master mode, the Slave zone is unavailable for modification and vice-versa.

Accessible Modbus Functions

The table below shows the different functions configurable according to the type of serial link used:

Function	RS485 Link	RS232 Link
Master number of retries	X	X
Master response time	X	X
Slave number	X	X
Transmission speed	X	X
Delay between frames	X	X
Data	<ul style="list-style-type: none"> ● ASCII (7 bits) ● RTU (8 bits) 	<ul style="list-style-type: none"> ● ASCII (7 bits) ● RTU (8 bits)
Stop	<ul style="list-style-type: none"> ● 1 bit ● 2 bits 	<ul style="list-style-type: none"> ● 1 bit ● 2 bits
Parity	<ul style="list-style-type: none"> ● Odd ● Even ● None 	<ul style="list-style-type: none"> ● Odd ● Even ● None
RX/TX signals	-	X
RTS / CTS delay	-	X
RX/TX/CTS(DCE Mode)	-	X
X: Accessible function -: Inaccessible function		

NOTE: All Modbus Serial communication parameters have default values.

The table below shows the default values for Modbus Serial communication parameters:

Configuration Parameter	Value
Mode	Master
Physical Line	RS485
Slave number	-
Delay between frames	2 ms
Transmission speed	19,200 bits/s
Parity	Even
Data Bits	RTU (8 bits)
Stop bits	1 bit

Application-linked Modbus Parameters

After configuring the communication channel, enter the application parameters.

These parameters are accessible from three configuration zones:

- The Type zone
- The Master zone
- The Slave zone

The following table describes the zones:

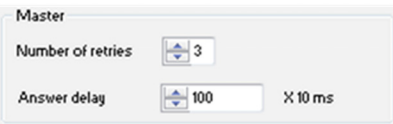
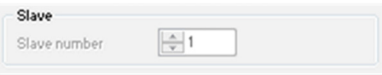
Zone	Screen	Description
The Type zone		This zone enables you to select the type of Modbus Serial to be used: <ul style="list-style-type: none"> ● Master: When the station concerned is the master. ● Slave: When the station concerned is a slave.
The Master zone		This zone enables you to enter the following parameters: <ul style="list-style-type: none"> ● Number of retries: Number of connection attempts made by the master before defining the slave as absent. The default value is 3. Possible values range from 0...15. A value of 0 indicates no retries by the Master. ● Answer delay: The time between the Master's initial request and a repeated attempt if the slave does not respond. This is the maximum time between the transmission of the last character of the Master's request and receipt of the first character of the request sent back by the slave. The default value is 1 second (100*10 ms). Possible values range from 10 ms to 10 s. <p>NOTE: The Answer delay of the Master must be at least equal to the longest Answer delay of the Slaves present on the bus.</p>
The Slave zone		This zone enables you to enter the processor's slave number. The default value is 1. Possible values range from 1...247.



Transmission-linked Modbus Parameters

After configuring the communication channel, enter the transmission parameters.

These parameters are accessible from five zones:

- The Transmission Speed zone
- The Delay between frames zone
- The Data zone
- The Stop zone
- The Parity zone

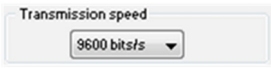
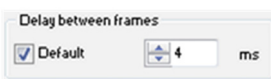
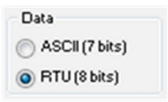
The following table describes the zones:

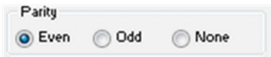
Zone	Screen	Description
The Transmission Speed Zone		This zone allows you to select the transmission speed of the Modbus Serial. The selected speed has to be consistent with the other devices. The configurable values are 300, 600, 1,200, 2,400, 4,800, 9,600 and 19,200 bits per second. NOTE: The transmission speed of 38,400 bps is not supported (300...19,200 bits/s) for all functions.
The Delay between frames zone		The Delay between frames is the minimum time separating two frames on reception. This delay is managed when the PLC (master or slave) is receiving messages. NOTE: The default value depends on the selected transmission speed. NOTE: The delay between frames should be the Default value in order to be Modbus compliant. In case a Slave is not conform, the value can be changed and should be identical for the Master and all Slaves on the Bus.
The Data zone		This zone allows you to enter the type of coding used to communicate using Modbus Serial. This field is set according to the other devices connected on the bus. There are two configurable modes: RTU mode: <ul style="list-style-type: none"> • The characters are coded over 8 bits. • The end of the frame is detected when there is a silence of at least 3.5 characters. • The integrity of the frame is checked using a word known as the CRC checksum, which is contained within the frame. ASCII mode: <ul style="list-style-type: none"> • The characters are coded over 7 bits. • The beginning of the frame is detected when the ":" character is received. • The end of the frame is detected by a carriage return and a line feed. • The integrity of the frame is checked using a byte called the LRC checksum, which is contained within the frame.
The Stop zone		This zone allows you to enter the number of stop bits used for communication. This field is set according to the other devices. The configurable values are: <ul style="list-style-type: none"> • 1 bit • 2 bits
The Parity zone		This zone enables you to determine whether a parity bit is added or not, as well as its type. This field is set according to the other devices. The configurable values are: <ul style="list-style-type: none"> • Even • Odd • None



Signal and Physical Line Parameters in Modbus

After configuring the communication channel, enter the signal and physical line parameters.

These parameters are accessible via three zones:

- The Physical line zone
- The Signals zone
- The RTS/CTS delay zone

The following table describes the zones:

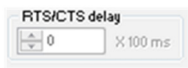
Zone	Screen	Description
The Physical line zone		In this zone, you can select the line for the channel 0 of the CPU between: <ul style="list-style-type: none"> • The RS232 line • The RS485 line
The Signals zone		In this zone, you can select the signals supported by the RS232 physical line: <ul style="list-style-type: none"> • RX/TX • RX/TX + RTS/CTS DCE mode If the RS485 is configured, the entire zone will be unavailable and the default value is RX/TX. NOTE: The Modbus Master is the default type. When RS232 is selected, DTE mode is not supported but DCE mode is supported.
The RTS/CTS delay zone		The RTS/CTS delay zone is available only when both RS232 and RX/TX+RTS/CTS check boxes are selected. An RTS/CTS flow control algorithm is selected if the default value is 0 ms. A value different from 0 enables an RTS/CTS modem control algorithm. The RTS/CTS flow control algorithm (DTE <-> DTE) is different from the RTS/CTS modem control algorithm (DTE <-> DCE) as follows: <ul style="list-style-type: none"> • The RTS/CTS flow control algorithm is related to the overflow reception buffer (full duplex). • The RTS/CTS modem control algorithm deals with the shared transmission process, e.g. a radio modem.

Modbus Serial Communication Programming

When used as the master in a Modbus link, MC80 supports several services via the READ_VAR, WRITE_VAR and DATA_EXCH communication functions.

Modbus Request	Function Code	Communication Function
Read bits	16#01 or 16#02	READ_VAR
Read words	16#03 or 16#04	READ_VAR
Write bits	16#0F	WRITE_VAR
Write words	16#10	WRITE_VAR
Other request	all	DATA_EXCH

When used as a slave in a Modbus link, it manages the following requests:

Modbus Request	Function Code	PLC Object
Read n output bits	16#01	%M
Read n output words	16#03	%MW
Write n output bits	16#0F	%M
Write n output words	16#10	%MW

Character Mode Communication

Character Mode Communication Configuration Screen

To access the Character mode communication configuration screen, open the **SerialPort** sub-directory in the project browser (*see page 111*), and select the Character mode link function.

The following figure shows the default configuration screen for Character mode communication:

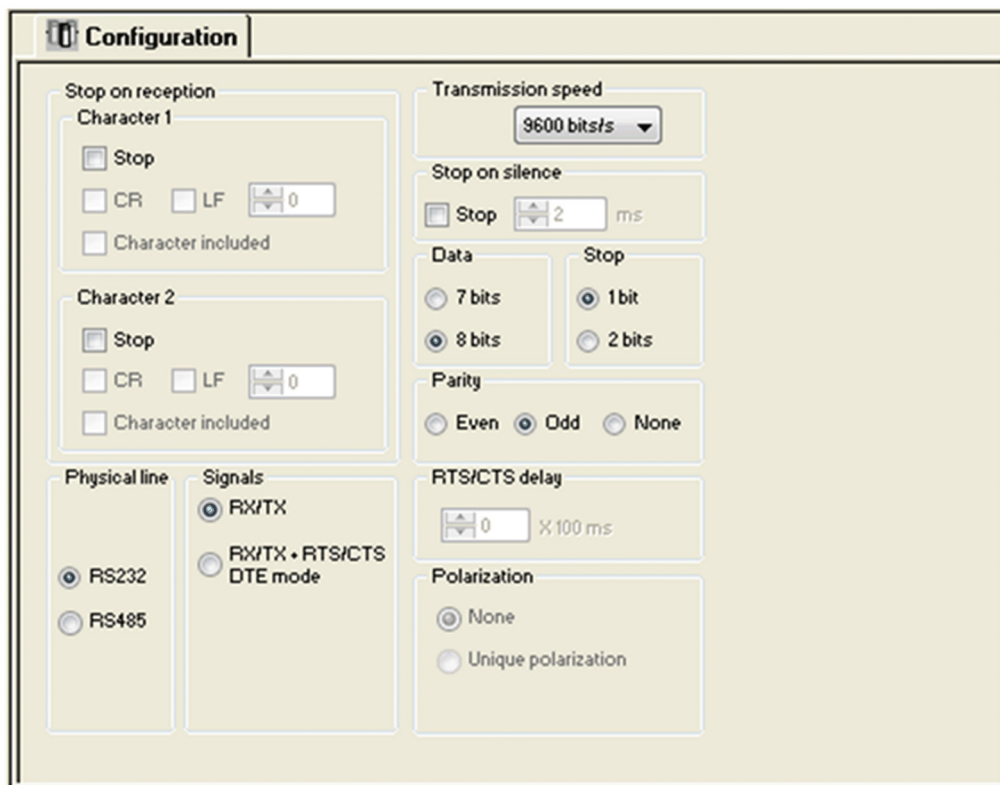

These zones are used to configure channel parameters. In the online mode, these zones are accessible. In the offline mode, these zones are accessible but some parameters may not be accessible and are grayed out.

The following table shows the different zones of the Character mode communication configuration screen:

Key	Element	Comment
1	Message end detection parameters	This parameters are accessible via two zones: <ul style="list-style-type: none"> ● Stop on reception ● Stop on silence
2	Transmission parameters	This parameters are accessible via four zones: <ul style="list-style-type: none"> ● Transmission speed ● Data ● Stop bits ● Parity
3	Signal and physical line parameters	This parameters are accessible via three zones: <ul style="list-style-type: none"> ● Physical line ● Signals ● RTS/CTS delay

Accessible Functions in Character Mode

The following table shows the different functions configurable according to the type of serial link used:

Function	RS485 Link	RS232 Link
Transmission speed	X	X
Data	<ul style="list-style-type: none"> ● 7 bits ● 8 bits 	<ul style="list-style-type: none"> ● 7 bits ● 8 bits
Stop	<ul style="list-style-type: none"> ● 1 bit ● 2 bits 	<ul style="list-style-type: none"> ● 1 bit ● 2 bits
Parity	<ul style="list-style-type: none"> ● Odd ● Even ● None 	<ul style="list-style-type: none"> ● Odd ● Even ● None
Stop on reception	X	X
Stop on silence	X	X
RX/TX Signals	X	X
RTS/CTS Signals	-	X
RTS/CTS delay	-	X
X: Accessible function -: Inaccessible function		

The following table shows the default values for Character mode communication parameters:

Configuration parameter	Value
Physical Line	RS232
Transmission speed	9,600 bits/s
Parity	Odd
Data Bits	8 bits
Stop bits	1 bit

Message End Detection Parameters in Character Mode

After configuring the communication channel, enter the message end detection parameters.

These parameters are accessible via two zones:

- The **Stop on reception** zone: stop on reception of a special character.
- The **Stop on silence** zone: stop on silence.

Selecting Stop on silence means that Stop on reception is deselected and vice versa.

The following table describes the zones:

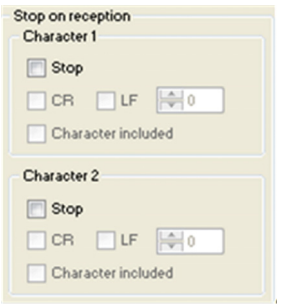
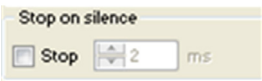
Zone	Screen	Description
<p>The Stop on reception zone</p>		<p>A reception request can be terminated once a specific character is received. Select the Stop option to configure the Stop on reception feature which can be activated by a specific end-of-message character:</p> <ul style="list-style-type: none"> ● CR: enables you to detect the end of the message by a carriage return. ● LF: enables you to detect the end of the message by a line feed. ● Data entry field: enables you to identify an end-of-message character other than the CR or LF characters, using a decimal value: <ul style="list-style-type: none"> ○ Between 0 and 255 if the data is coded over 8 bits ○ Between 0 and 127 if the data is coded over 7 bits ● Character included: enables you to include the end-of-message character in the reception table of the PLC application. <p>It is possible to configure two end-of-reception characters. For example, the end-of-reception of a message can be detected by an LF or CR character.</p>
<p>The Stop on silence zone</p>		<p>This zone enables you to detect the end of a message on reception by the absence of message end characters over a given time. Stop on silence is validated by checking the Stop check box. The duration of the silence (expressed in milliseconds) is set using the data entry field.</p> <p>NOTE: The available values range from 1...10,000 ms depending on the transmission speed selected.</p>

Transmission Parameters in Character Mode

The transmission parameters in Character mode is same as Modbus Serial communication .

Signal and Physical Line Parameters in Character Mode

After configuring the communication channel, enter the signal and physical line parameters.

These parameters are accessible via 3 zones:

- The Physical line zone
- The Signals zone
- The RTS/CTS delay zone

The following table describes the zones:

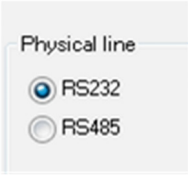
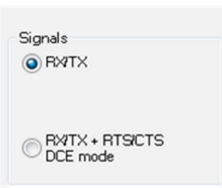
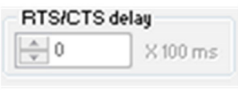
Zone	Screen	Description
The Physical line zone		In this zone, you can select the line for the channel 0 of the CPU between: <ul style="list-style-type: none"> • The RS232 line • The RS485 line
The Signals zone		In this zone, you can select the signals supported by the RS232 physical line: <ul style="list-style-type: none"> • RX/TX • RX/TX + RTS/CTS Full Duplex (DTE mode) If the RS485 is configured, the entire zone is grayed out and the default value is RX/TX.
The RTS/CTS delay zone		The RTS/CTS delay zone is available only when both RS232 and RX/TX+RTS/CTS check boxes are selected. An RTS/CTS flow control algorithm is selected: before a character string is transmitted, the system waits for the CTS (Clear To Send) signal to be activated. This zone enables you to enter the maximum waiting time between the two signals. When this value is timed out, the request is not transmitted on the bus. The Configurable values range from 0...10 s. NOTE: The default value is 0 ms. NOTE: A value of 0 s indicates that the delay between the two signals is not managed.

Character Mode Communication Programming

The three specific communication functions are defined for sending and receiving data via communication channel in Character mode:

- PRINT_CHAR: send a character string (maximum of 1,024 bytes).
- INPUT_CHAR: read a character string (maximum of 1,024 bytes).
- INPUT_BYTE (see *Unity Pro, Communication, Block Library*): read a byte array (maximum of 1,024 bytes).

Since the Modicon MC80 PLC serial port is full duplex with RS232 link, a PRINT_CHAR function can be sent when an INPUT_CHAR function is sent and is in pending state.

NOTE: For INPUT_CHAR function, a configured time-out is necessary to acknowledge the activity bit of the function, if the channel is configured without Stop on silence. For PRINT_CHAR function, it is advisable but not necessary to configure a time-out.

Configuring the Ethernet Port of the CPU

Configuration

In the application browser, you can create an Ethernet network from the Communication node similar to the older versions of Control Expert (formerly Unity Pro).

To link the network to the Ethernet port of the CPU, use the Ethernet configuration screen.

Open the Ethernet configuration screen:

- Double-click the Ethernet connector node in the application browser.
- Or
- Double-click the Ethernet hotspot of the CPU in the bus editor.

Creating a Network

Create a logical Ethernet network:

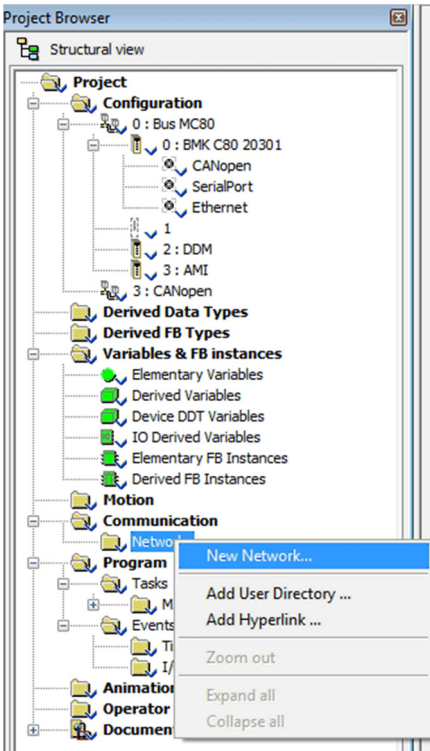
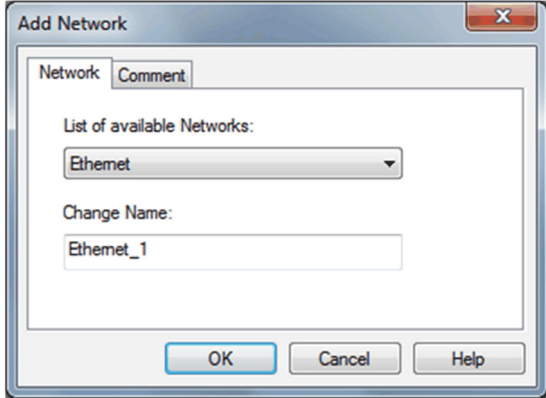
Step	Action
1	<p>In the Project Browser, right-click the Network subdirectory in the Communication directory and select the New Network option. Result: The Add Network screen appears.</p> 
2	<p>Choose Ethernet in the List of available networks and choose a meaningful name for your selection:</p> 
3	<p>Click OK. A new logic network will be created.</p>

Accessing a Network Configuration

Access the logical Ethernet network configuration:

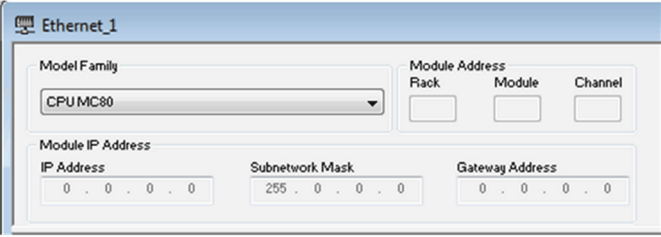
Step	Action
1	Open the project browser in order to see the logic networks of your application.
2	Right-click the Ethernet logic network to be configured and select Open . Result: The Ethernet configuration screen is displayed.
	
3	Scroll to choose the Model Family of your network.

The configuration screen is divided into several zones:

- **Model Family:** Select the model family for configuration.
- **Module Address:** This zone is unavailable.
- **Module IP Address:** This field displays the module’s IP address.

Linking the Ethernet Network to the Embedded Ethernet

Configure the Ethernet link and link the Ethernet network created in the communication manager:

Step	Action
1	Open the Ethernet configuration screen.
2	Configure the Ethernet link with the ETH TCP IP function.
3	Link to the Ethernet network.

Services available for the MC80 CPU

These Network Services are configured inside Control Expert for the MC80 CPU:

- Security
- IP Configuration
- Simple Network Management Protocol (SNMP) (Client)
 - Standard MIB Only
 - MIB Transparent Factory not supported
- Rapid Spanning Tree Protocol (RSTP)
- Bandwidth

Security

This Security Service applies to the Cyber Security of the MC80 network.

Access the **Security** tab from the index page:

Step	Action
1	Access the module configuration screen.
2	Select the Security tab as shown in the following figure.

This is the Security tab:

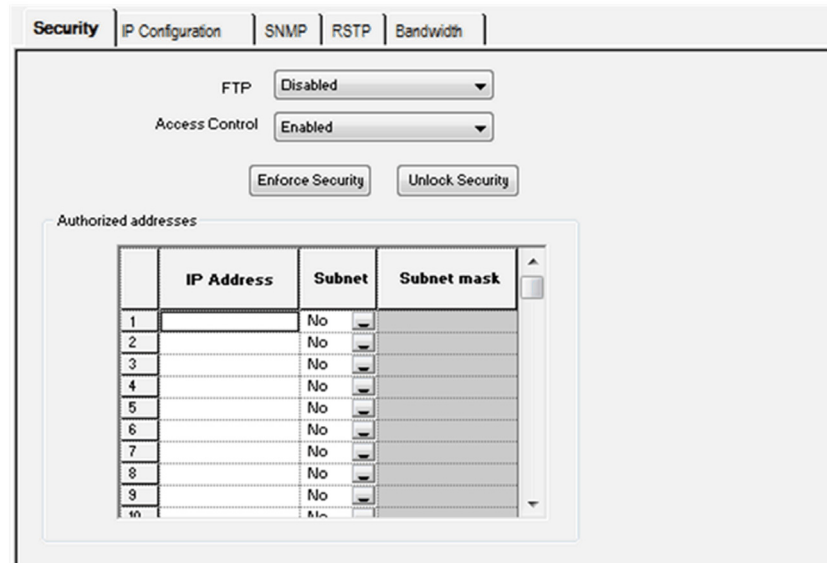

This table describes the features behavior with limited checks:

Feature	Characteristic
FTP	Enabled or Disabled
Access Control	Enabled or Disabled
ACL with 128 lines	1 hidden reserved for USB
NOTE: By default, the Security is Enforced (FTP Disabled and Access Control Enabled).	

Access Control List (ACL)

The list of authorized addresses applies only to the devices that can communicate with the MC80 CPU via the port 502 server. The list also applies to the CPU firmware downloads.

When the access control is enabled, add the IP addresses of the authorized addresses. The devices can communicate only with authorized addresses.

To define the list of authorized addresses, you can enter one of the following:

- an IP address in the IP Address column and select NO in the Subnet column
- a subnet address in the IP Address column, select YES in the Subnet column and enter subnet mask in the Subnet Mask column.

NOTE: The subnet in the IP Address column can be the subnet itself or any IP address of the subnet. If you enter a subnet without a subnet mask, a detected error displays stating that the screen cannot be validated.

You can enter up to 128 authorized IP addresses.

File Transfer Protocol (FTP)

The Schneider Electric Ethernet devices use FTP for various tasks including firmware loading and retrieving error logs.

Schneider Electric recommends you to disable FTP when not required, as FTP is vulnerable to various cyber security attacks.

IP Configuration

Access the **IP configuration** tab from the index page:

Step	Action
1	Access the module configuration screen.
2	Select the IP configuration tab as shown in the following figure.

This is the IP configuration tab:

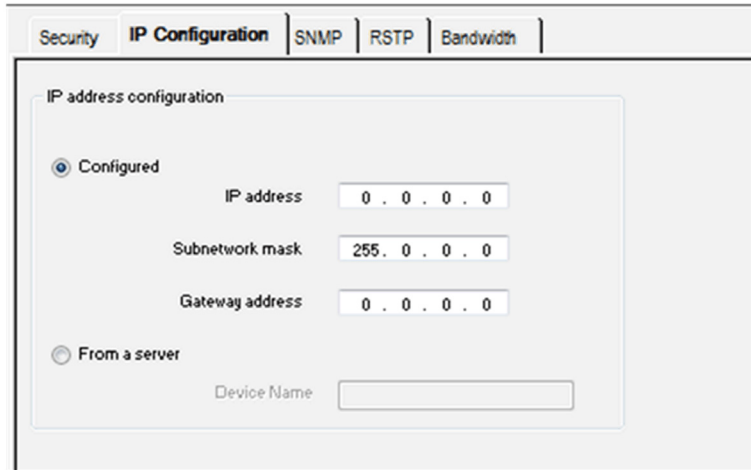

These are the configuration parameters for IP addresses:

Zone	Description
IP address configuration	<p>On the IP Configuration tab, you can define the IP address of a module in the IP address configuration zone. The options are:</p> <ul style="list-style-type: none"> ● Configured: Manually enter the IP address, subnetwork mask, and gateway address. ● From a server: The configuration is supplied by a server device. <p>NOTE: To configure IP addresses, obtain the appropriate network address and subnetwork mask from your system administrator.</p>
Configured	<p>Selecting the Configured option allows manual configuration according to your own requirements:</p> <ul style="list-style-type: none"> ● IP Address: The IP address of the module ● Subnetwork mask: The mask defines the part allocated to the subnetwork identifier in the IP address. ● Gateway Address: The gateway address is the IP address of the default gateway to which messages for other networks are transmitted. <p>NOTE:</p> <ul style="list-style-type: none"> ● If the module is connected to an existing TCP/IP network, the IP addresses are administered globally, therefore the IP parameters must be configured. Otherwise there may be an instance of duplicate IP addresses on the existing network. ● The configured IP address is valid only when the lower rotary switch turns to "Stored" position.
From a server	<p>Selecting the From a server option allows the configuration of module's IP address from a remote device acting as a DHCP server. When the From a server button is active:</p> <ul style="list-style-type: none"> ● Leaving the Device Name field empty facilitates communications that are compatible with any setting on the rotary switches. ● To use a device name in the Device Name field, set the lower rotary switch to its STORED position. If you set the switch any other position, the result depends on the setting of the lower rotary switch, as described in the Ethernet Port Status table. ● The configured IP parameters have no effect and are grayed out. <p>NOTE: The maximum length for the device name is 16 characters. Valid characters include alphanumerics (0...9, A...Z) and underscores.</p>

NOTE: TCP/IP communications use the Ethernet II frame format, which complies with the RFC 894 standard.

Port Status

The status of the Ethernet port depends on the IP address configuration in the application and the setting on the rotary switches:

Application	Switch Setting				
	DHCP (device name from rotary switches)	DHCP	STORED	CLEAR IP	DISABLED
None	DEFAULT: Get IP address. (1)	DEFAULT: Get IP address. (1)	DEFAULT: Use default IP address. (1)	DEFAULT: This switch setting implements device's default IP parameters regardless of the application type.	LED off. This switch setting stops communications between the module and the network, so the application type is inconsequential.
Configured	MISMATCH: Get IP address. (1)	MISMATCH: Get IP address. (1)	NO ERROR: Get IP address from application. (2)	Configured	
From a server without device name (3)	NO ERROR: Get IP address. (2)	NO ERROR: Get IP address. (2)	NO ERROR: Get IP address with DHCP. (2)	From a server without device name (3)	
From a server with device name	NO ERROR: Get IP address. Device name derived from switches (2) (5)	MISMATCH: Get IP address. (1)	NO ERROR: Get IP address with DHCP (device name from application). (2)(4)	From a server with device name	

- (1) Start default services only
- (2) Start application-configured services
- (3) Leaving the From a server/Device Name field empty on the IP Configuration tab facilitates communications that are compatible with any rotary switch setting.
- (4) To use the device name from the IP Configuration tab in the Control Expert application, the lower rotary switch must be set to one of its STORED positions.
- (5) When the server returns a name that matches the one you configure on the IP Configuration tab, communications are OK. When there is a mismatch, there is a communications error.
- (6) The MC80 Ethernet modules will not receive an IP address from a DHCP server on application download if the IP configuration has not changed.

 CAUTION

UNINTENDED EQUIPMENT OPERATION

The communications port can enter the idle state when the position of the rotary switches does not match the port network configuration in the application. For example, the switches may be set to DHCP while the application calls for a fixed IP address.

Failure to follow these instructions can result in injury or equipment damage.

SNMP

Access the **SNMP** tab from the index page:

Step	Action
1	Access the module configuration screen.
2	Select the SNMP tab as shown in the following figure.

This is the SNMP tab:

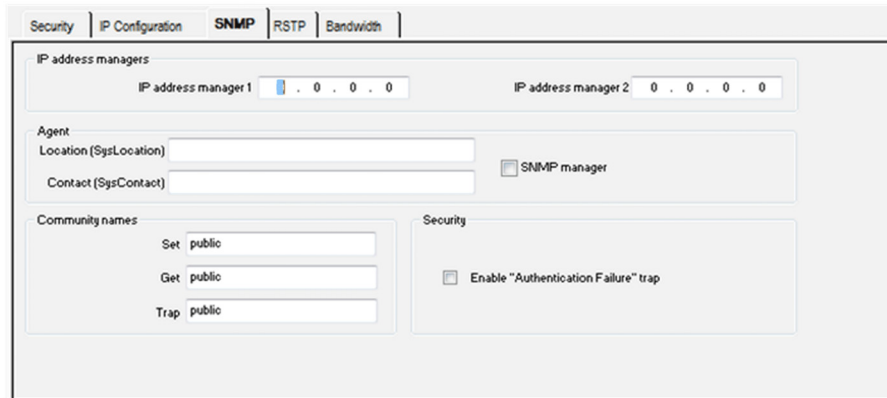

This procedure gives the configuration principles for SNMP:

Step	Action
1	Enter the IP address managers addresses: <ul style="list-style-type: none"> ● IP address manager 1 ● IP address manager 2
2	Fill in the Agent fields: <ul style="list-style-type: none"> ● Location (SysLocation) ● Contact (SysLocation) Or alternatively check the SNMP manager check box to indicate that the information will be completed by the SNMP manager.
3	If you want to set access rights, fill in the Community names : <ul style="list-style-type: none"> ● Set ● Get ● Trap

These are the SNMP configuration parameters:

Zone	Description
SNMP	Parameters on the SNMP configuration tab are divided into four categories: <ul style="list-style-type: none"> ● the IP addresses of SNMP manager devices ● SNMP agents ● the community names ● security NOTE: Only 7-bit ASCII characters can be used in the character string entry fields.
IP address managers	This zone allows you to complete the IP addresses of the SNMP managers. The modules authorize a maximum of two managers. These addresses are used during possible transmission of events (TRAP). The transmission of supervised data is detailed at the topic SNMP.
Agent	This zone allows the localization and identification of an agent from the SNMP manager. It consists of two fields: <ul style="list-style-type: none"> ● The Location (SysLocation) field: Indicates the physical location of the device (32 characters maximum). ● The Contact (SysLocation) field: Indicates the person to contact for device management and the method of contact (strings of 32 characters maximum). ● If you prefer to have this information assigned by an SNMP Manager tool for network management, check the SNMP Manager check box.
Community names	This zone is used to define community names for the Set , Get and Trap utilities. It consists of three fields: <ul style="list-style-type: none"> ● The Set field defines the community name for the Set utility (strings of 16 characters maximum). The default value of the field is Public. ● The Get field defines the community name for the Get utility (strings of 16 characters maximum). The default value of the field is Public. ● The Trap field defines the community name for the Trap utility (strings of 16 characters maximum). The default value of the field is Public. The purpose of these fields are to define the access rights for the MIB objects of the SNMP agent (local module) in relation to requests sent by the manager. Example: If the manager sends a SetRequest request with the community name <i>Test</i> and the module has the community name <i>Public</i> , the request is not executed.
Security	This zone contains the Enable "Authentication Failure" trap check box. Checking this box allows you to validate the transmission of an authentication failure event (TRAP) from the SNMP agent to the configured manager. In this way, the agent warns the manager that the request has been refused following an identification error (community name configured in the manager is different from the one configured in the agent).

⚠ CAUTION

UNEXPECTED NETWORK BEHAVIOR - SNMP PARAMETERS RESET

The SNMP manager is able to modify the value of certain configurable parameters (Enabling "Authentication failure," Location, Contact, etc.). The **SNMP Manager** box is not checked and there is a cold start, warm restart, or application download, the initially configured values are restored.

Failure to follow these instructions can result in injury or equipment damage.

RSTP

Access the **RSTP** tab from the index page:

Step	Action
1	Access the module configuration screen.
2	Select the RSTP tab as shown in the following figure.

This screen shows the RSTP screen for an MC80 Ethernet network, you can choose the priority of the bridge from the **Bridge Priority** arrow:

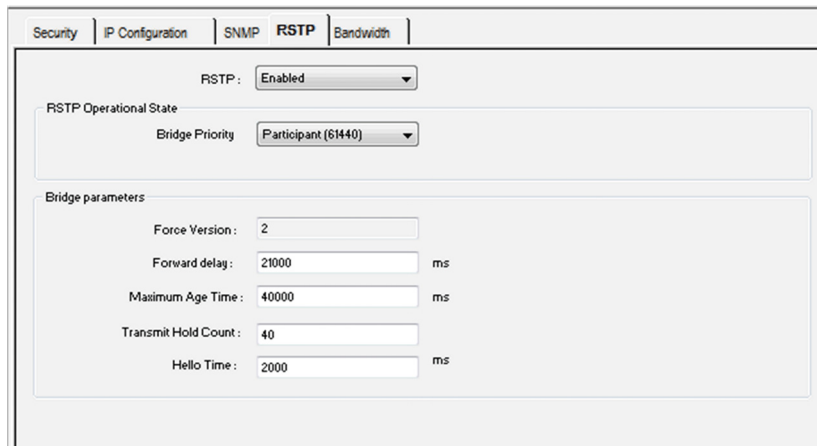

These are the RSTP configuration parameters:

Zone	Description
Bridge Priority	Select one of the following values in the drop-down list: <ul style="list-style-type: none"> ● Root (0) ● Backup Root (4096) ● Participant (32768) <p>NOTE: Network switches running RSTP software periodically exchange information about themselves using special packets called Bridge Protocol Data Units (BPDUs), which act as a heartbeat. The Bridge Priority value is stored in the BPDU and it establishes the relative position of the switch in the RSTP hierarchy.</p>
Forward delay	The delay used by STP Bridges to transition Root and Designated Ports to Forwarding.
Maximum Age	This value is set to the length of time, from 6...40 seconds the switch waits for receipt of the next hello message, before initiating a change to the RSTP topology. Default = 40 s.
Transmit Hold Count	The maximum number of BPDUs, from 1...40, the switch can transmit per second. Default = 40.
Hello Time	When the frequency is set at 2 seconds, the embedded switch sends heartbeat BPDUs.

Bandwidth

Access the **Bandwidth** tab:

Step	Action
1	Access the module configuration screen.
2	Select the Bandwidth tab as shown in the following figure.
3	Select the appropriate Ethernet Environment zone. <ul style="list-style-type: none"> ● Isolated: Lessens the impact of Ethernet communication on the scan by limiting the number of polled Ethernet messages to 500 per second ● Mastered: Increases the maximum number of polled messages to 1,000 per second ● Open: Increases the maximum number of polled messages to 2,200 per second
4	Enter the estimate for the Messaging information zone.
5	If the module overflows, the message "The maximum number of messages for the Extended Ethernet network must not exceed 2,000 messages" appears.

This is the Bandwidth tab for an MC80 Ethernet network:

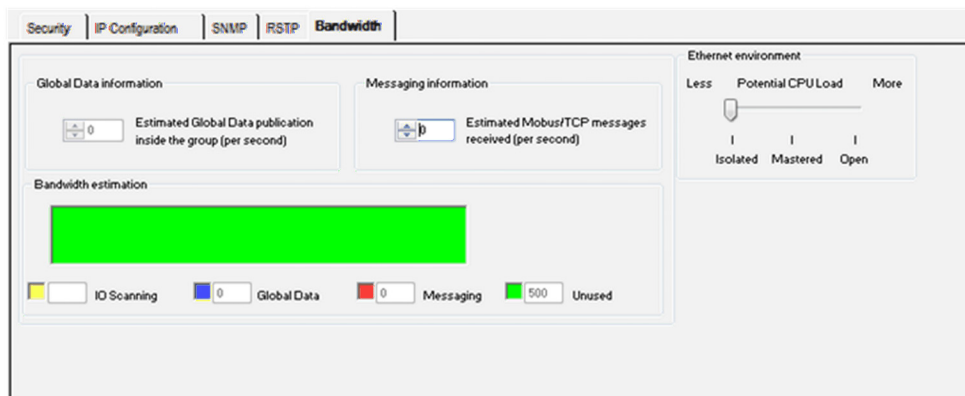

Port Features

These are the features of the Ethernet port:

Feature	Description
addressing	STORED
	CLEAR IP
	DHCP
supported application protocols	Stored IP (from application)
	IP from BootP
	IP from DHCP
	MAC-based IP
	Modbus messaging
	FDR client
	FDR server
	SNMP agent
	Bandwidth Management
	FTP
	ARP
RSTP	
auto MDI/MDI-X	supported
auto-negotiation	supported
connector type	dual-shield RJ45
max. connections for Modbus TCP (port 502) all services included	16 Modbus TCP connections as server

Feature	Description
max. connections for Modbus TCP (port 502) messaging only	Modbus TCP connections as server not taking into account IO scanner, from which only one connection is used by Control Expert in programming mode.
	Modbus TCP connections as client not taking into account IO Scanner, i.e. 6 simultaneous communication EFB on Ethernet.
max. connections for FTP	1 (for firmware upgrade only)
max. server requests per cycle	8
max. client requests per cycle	4
max. message length	1026 including network headers
max. message throughput for Modbus TCP	This value is a function of the PLC cycle (PLC cyc * max req/cyc).
	The default value is not configured in an M340 system.
max. message throughput for Modbus TCP	The Ethernet Environment (or CPU load) identified in the Bandwidth window: <ul style="list-style-type: none"> ● isolated ● mastered ● open

CANopen Configuration

Bus Configuration

Follow the below steps to access the CANopen field bus:

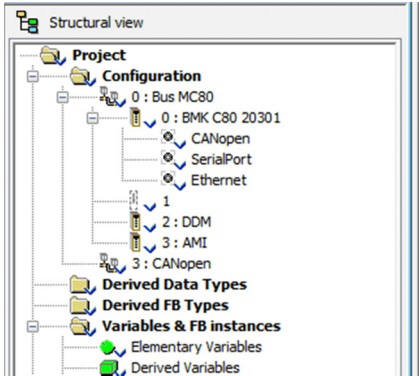
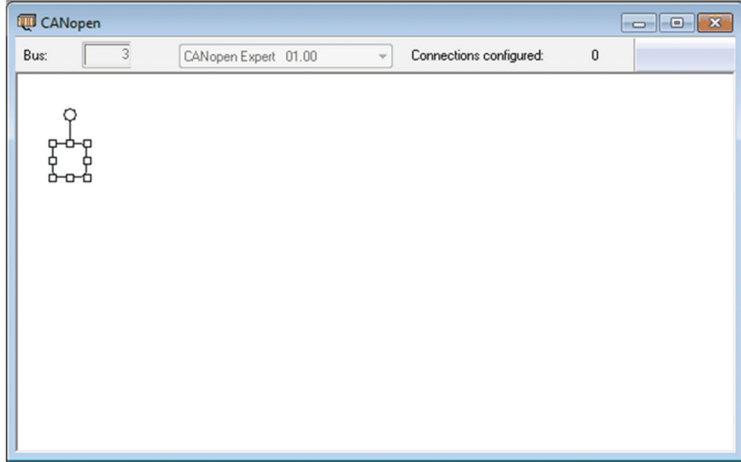
Step	Action
1	<p>From the project navigator, expand the Configuration directory. Result: The following screen appears:</p> 
2	<p>To open the CANopen bus screen, select one of the following methods:</p> <ul style="list-style-type: none"> • double-click the CANopen directory • select the CANopen sub-directory and select Open in the contextual menu. <p>Result: The CANopen window appears.</p> 

Follow the steps below to add a device connected to the CANopen bus:

Step	Action
1	Access the CANopen configuration screen.
2	<p>Double-click the place where the module should be connected. Result: The New Device screen appears.</p>
3	<p>Enter the number of the connection point corresponding to the address. By default, the Unity Pro software offers the first free consecutive address.</p>
4	<p>In the Communicator field, select the element type enabling communication on the CANopen bus. For modules with built-in communicators, this window does not appear.</p>
5	<p>Validate with Ok. Result: The module is declared.</p>

Follow the steps below to delete a device connected to the CANOpen bus:

Step	Action
1	Access the CANOpen configuration screen.
2	Right-click the connection point of the device to be deleted, then click Delete the drop .

Follow the steps below to move a device connected to the CANOpen bus:

Step	Action
1	Access the CANOpen configuration screen.
2	Select the connection point to be moved (a frame surrounds the selected connection point).
3	Drag and drop the connection point to be moved to an empty connection point. Result: The Move Device screen appears.
4	Enter the number of the destination connection point.
5	Confirm the new connection point by pressing OK. Result: The Move Device screen appears.
6	Confirm the modification by selecting Yes to modify the addresses of the inputs/outputs objects in the program and move the variables associated with these objects.

Follow the steps below to duplicate a device connected to the CANOpen bus:

Step	Action
1	Access the CANOpen configuration screen.
2	Right-click the device to be copied, then click Copy.
3	Right-click the connection point desired, then click Paste. Result: The New Device screen appears.
4	Enter the number of the destination connection point.
5	Confirm the new connection point by selecting OK.

Master Configuration

The Master configuration and the devices configuration are stored in the PLC application in order to be used by the CANOpen stack of the MC80 firmware.

The following table describes how to Access the CANOpen Master Configuration screen:

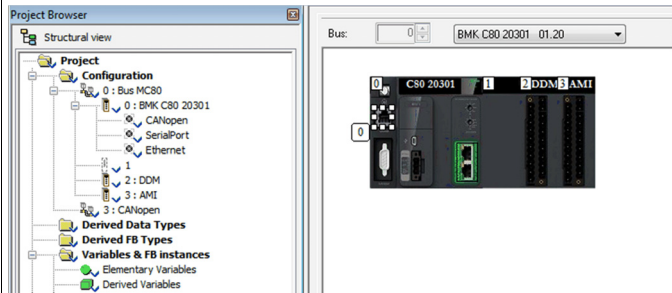
Step	Action
1	Open the CANOpen directory under BUS MC80 directory Result: The following screen appears: 
	Double-click the processor's CANOpen port.

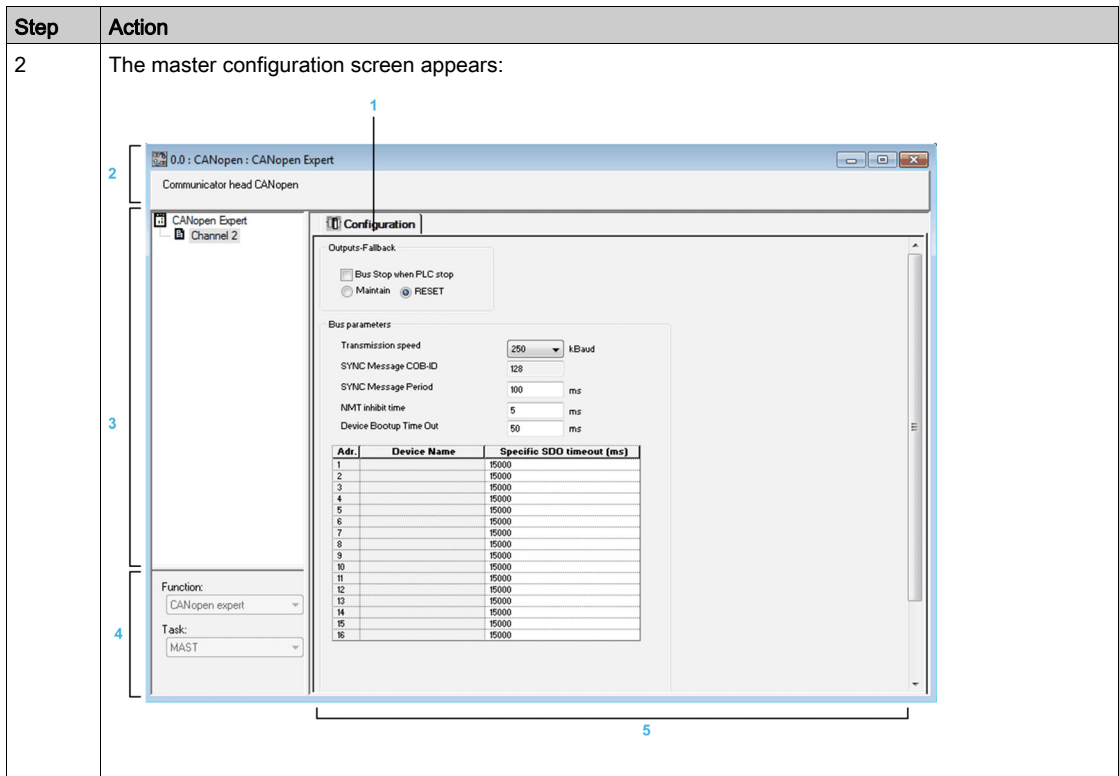

The following table describes the different areas which make up the master configuration screen:

Address	Element	Function
1	Tab	The tab in the foreground indicates the type of screen displayed. In this case, it is the configuration screen.
2	Module area	This area is made up of the abbreviated heading of the processor equipped with a CANopen port.
3	Channel area	This zone allows you to select the communication channel to be configured. By clicking the device, you display the tabs: Overview: Gives the characteristics of the built-in CANopen port, By clicking a channel, you display the tabs: Configuration: Enables you to declare and configure the CANopen master
4	General parameters area	This field enables you to: <ul style="list-style-type: none"> Associate the CANopen bus to an application task <ul style="list-style-type: none"> MAST which is the master task The tasks are asynchronous in relation to exchanges on the bus.
5	Configuration area	This field enables you to: <ul style="list-style-type: none"> Configure the parameters of the CANopen bus.

The following table describes the configuration parameters for CANopen Master Configuration screen:

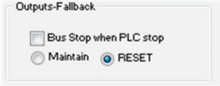
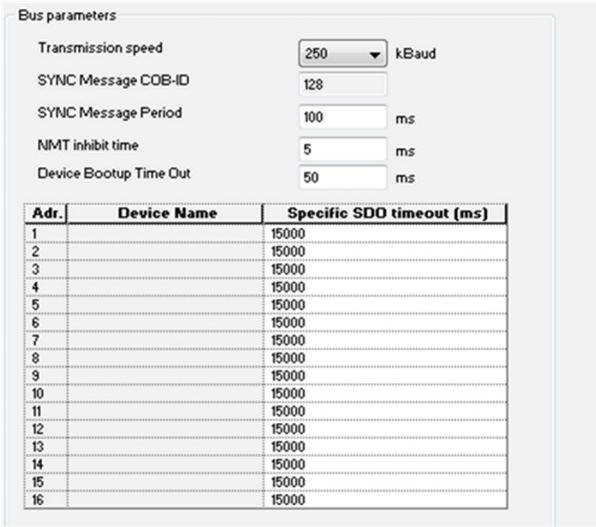
Parameter	Description																																																			
Outputs-Fallback	<p>The fallback information area contains two options, which defines the behavior of the device when the CPU is in STOP or in HALT:</p> <ul style="list-style-type: none"> ● Maintain: Maintains outputs (values are kept), ● Reset: Resets outputs (values are set to 0).  <p>NOTE: The Bus Stop when PLC stop check box in the fallback area configuration is only available in CANopen expert mode.</p> <ul style="list-style-type: none"> ● If it is not checked: the CANopen bus remains in RUN after a PLC stop and the global strategy of fallback is applied to the outputs according to Maintain or Reset radio button. ● If it is checked: the CANopen bus is stopped when a PLC stop; in this case, Maintain and Reset radio buttons are greyed out. 																																																			
Bus Parameters	<p>To configure the bus, it is necessary to indicate the following parameters:</p> <ul style="list-style-type: none"> ● Transmission speed – 250 kBauds default ● SYNC Message COB-ID - 128 default ● SYNC Message Period - 100 ms default ● NMT inhibit time - 5 ms default. During Bootup, the CANopen Master implements a delay between each NMT messages to avoid slave overload. The value must be given in multiple of 100 µs. The value 0 disables the inhibit time. ● Device Bootup Time Out - 50 ms default. The global SDO timeout for the master is related to the scanning of the network. During this time, the master reads the object 1000 of each slave to analyze the CANopen bus configuration. ● Specific SDO timeout: 15,000 ms default. The slaves SDO timeout is necessary for devices with long response times i.e. for accesses to the objects 1010,1011,1F50. A grid displays all present devices with the Nodeld, the name and the timeout value.  <table border="1"> <thead> <tr> <th>Adr.</th> <th>Device Name</th> <th>Specific SDO timeout (ms)</th> </tr> </thead> <tbody> <tr><td>1</td><td></td><td>15000</td></tr> <tr><td>2</td><td></td><td>15000</td></tr> <tr><td>3</td><td></td><td>15000</td></tr> <tr><td>4</td><td></td><td>15000</td></tr> <tr><td>5</td><td></td><td>15000</td></tr> <tr><td>6</td><td></td><td>15000</td></tr> <tr><td>7</td><td></td><td>15000</td></tr> <tr><td>8</td><td></td><td>15000</td></tr> <tr><td>9</td><td></td><td>15000</td></tr> <tr><td>10</td><td></td><td>15000</td></tr> <tr><td>11</td><td></td><td>15000</td></tr> <tr><td>12</td><td></td><td>15000</td></tr> <tr><td>13</td><td></td><td>15000</td></tr> <tr><td>14</td><td></td><td>15000</td></tr> <tr><td>15</td><td></td><td>15000</td></tr> <tr><td>16</td><td></td><td>15000</td></tr> </tbody> </table> <p>NOTE: Only 16 devices are supported in 16 possible addresses from 1...16.</p>	Adr.	Device Name	Specific SDO timeout (ms)	1		15000	2		15000	3		15000	4		15000	5		15000	6		15000	7		15000	8		15000	9		15000	10		15000	11		15000	12		15000	13		15000	14		15000	15		15000	16		15000
Adr.	Device Name	Specific SDO timeout (ms)																																																		
1		15000																																																		
2		15000																																																		
3		15000																																																		
4		15000																																																		
5		15000																																																		
6		15000																																																		
7		15000																																																		
8		15000																																																		
9		15000																																																		
10		15000																																																		
11		15000																																																		
12		15000																																																		
13		15000																																																		
14		15000																																																		
15		15000																																																		
16		15000																																																		

Device Configuration

To configure a slave, perform the following actions:

Step	Action
1	Access the CANopen bus configuration screen.
2	Double-click the slave to be configured.
3	Configure the Bootup Procedure using the Bootup tab.
4	Integrate a third party product using the Object Dictionary tab.
5	Configure the usage function using the Configuration tab.
6	Configure the PDOs using the PDO tab.
7	Select the error control using the Error control tab.

The following figure shows an example of the configuration screen of a slave:

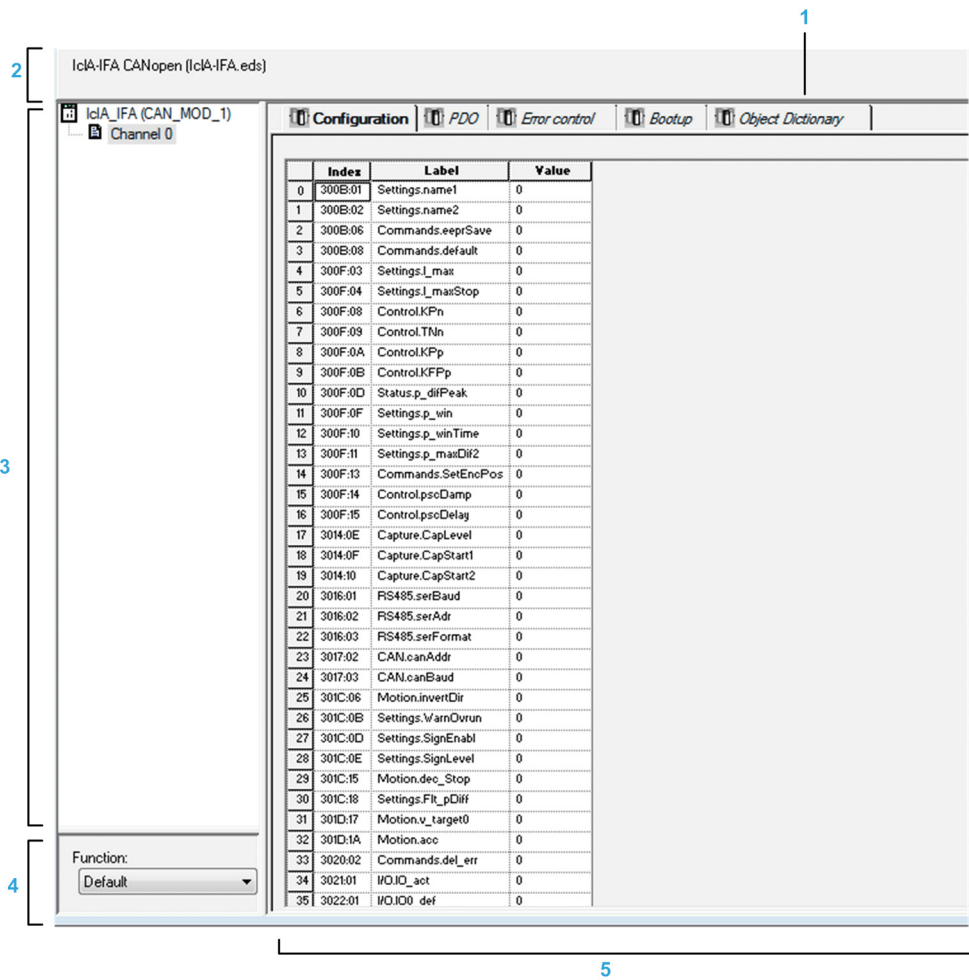

The following table shows the various elements of the configuration screen and their functions:

Address	Element	Function
1	Tab	The tab in the foreground indicates the type of screen displayed. In this case, it is the configuration screen.
2	Module area	Gives a reminder of the device's shortened name.
3	Channel area	This zone allows you to select the communication channel to be configured. By clicking the device, you display the following tabs: <ul style="list-style-type: none"> ● Description: Gives the characteristics of the device ● CANopen: Allows you to access SDO (in online mode) ● Device DDT: Pre-symbolizing of the input/output objects By clicking the channel, you display the following tabs: <ul style="list-style-type: none"> ● PDO (input/output objects) ● Error control ● Bootup ● Object Dictionary ● Configuration
4	General parameters area	This field allows you to select the slave function.
5	Configuration area	This area is used to set up the channels of the devices. Some devices can be configured with an external tool. In this case, the configuration is stored in the device and you cannot enter configuration parameters because this field is empty.

The animation of the CANopen bus editor is based on:

- %S118 for the general bus animation
- %SW172 (List of CANopen operational slaves) for animating the drops health

The following screen shows the CANopen Device PDO screen:

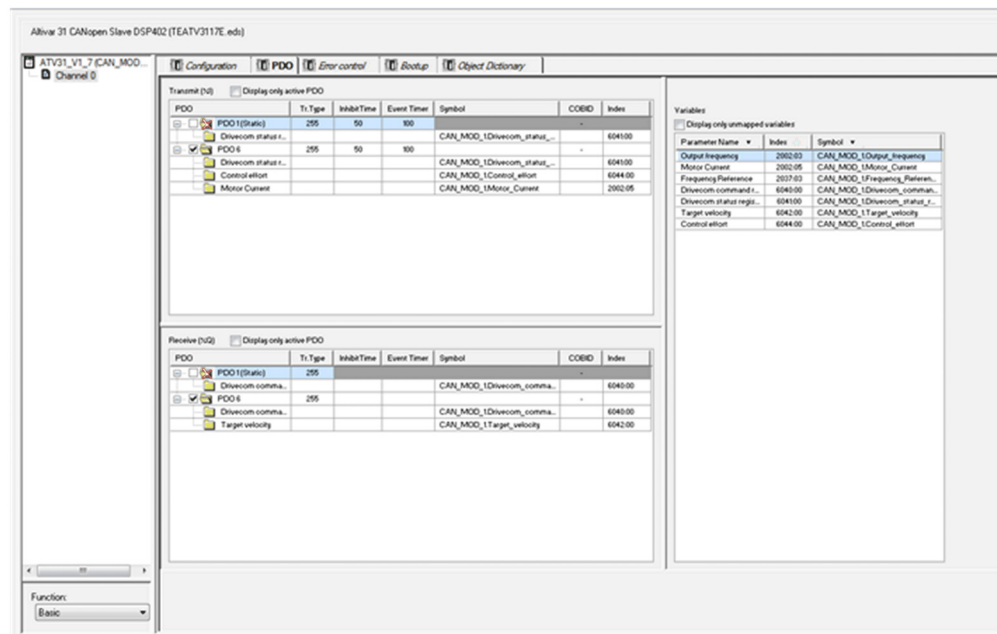

The following table lists the behavior of configuring CANopen devices in Unity:

Zone	Description
PDO	PDOS make it possible to manage the communication flow between the CANopen Master and the slaves. The PDO tab allows you to configure a PDO. <ul style="list-style-type: none"> ● Transmit PDOS: Information transmitted by the Slave to the Master, ● Receive PDOS: Information received by the Slave from the Master, ● Variables: Variables that can be mapped to the PDOS. To assign a variable to a PDO, drag and drop the variable into the desired PDO. No variable can be assigned with a static PDO.
Error Control	The Error control tab for CANopen slave modules allows you to configure monitoring.
Bootup	The goal of bootup procedure tab is to bypass the standard bootup procedure for devices which do not comply with CANopen standards.
Object Dictionary	The Object Dictionary tab allows you to configure and integrate third party products, by: <ul style="list-style-type: none"> ● Force parameters to be transmitted even if they are unchanged, by selecting the associated checkbox of each parameter. ● Block parameters that do not need to be sent to the device, by unselecting the associated checkbox of each parameter. ● Set objects to a specific value just before (prologue), or just after (epilogue) the standard boot up procedure. ● Modify the current value of an object (except read only objects), if the value box is not greyed out. By default, if the current value is modified, the object is sent. Nevertheless, after filling the box, you still have the choice to modify this behaviour, by removing the mark of the checkbox in order to block the object sending. To prevent programming redundancies or conflicts, parameters which can be modified in other tabs, Configuration, PDO or Error Control, are greyed out in the Object Dictionary tab.
NOTE: The I/O vision of CANopen devices is based on Device DDT.	

Hardware Catalog Manager

The Catalog Manager is a software tool that allows management of CANopen devices in the Unity Pro catalog database.

The Catalog Manager is a separate software that can be used to:

- Integrate third party products.
- Add, remove and configure access to CANopen devices on the fieldbus.
- Minimize the size of the CPU memory reserved for a given equipment.
- Customize the user interface.

The Unity user interface works on a catalog database which is installed with Unity Pro, and uses some basic services from the Unity Pro installation. Therefore Unity Pro software must be installed on your workstation, for the Catalog Manager to work.

NOTE: An overview of the Catalog Manager in read only mode is available in Unity Pro through the Hardware Catalog.

The Catalog Manager is composed of three levels of data:

- Device Families
- Devices
- Functions

The table below shows the procedure to launch the Catalog Manager:

Step	Action
1	Verify that Unity Pro software is not running <ul style="list-style-type: none"> ● if Unity Pro Software is running, close it ● if Unity Pro Software is not running, go to the next step
2	Select: Start ->Programs->Schneider Electric->Unity Pro->Hardware Catalog Manager

The following screen shows the Hardware Catalog Manager screen:

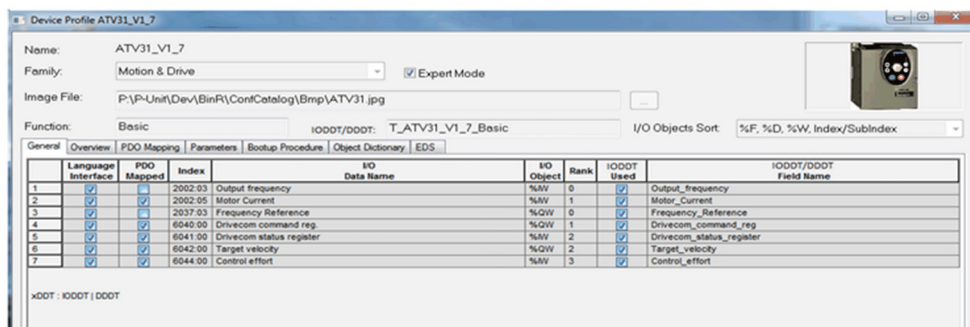

The following table describes the Hardware Catalog Manager screen:

Zone	Description
Overview	In this screen, you can enter a text description of the device and the related functions. It will be displayed in the Unity Module Editor.
PDO Mapping	The PDO mapping tab opens a CANopen expert screen for PDO configuration. The PDO mapping configuration is composed of 3 parts: <ul style="list-style-type: none"> ● Transmit PDOs ● Receive PDOs ● Variables
Parameters	The parameters tab is used to modify the properties of parameters. The properties of parameters are: <ul style="list-style-type: none"> ● Index: Indicates the index and the sub-index of the parameter (not editable). ● Parameter name: Indicates the name of the parameter (not editable). ● Minimum/Maximum: Indicates the range of authorized value (not editable). ● Value: Indicates the parameter value (editable) and is initialized with the default value find in the EDS. ● Attribute: <ul style="list-style-type: none"> ○ Editable: The parameter is editable in Unity Pro CANopen screen (default value). ○ Read only: The parameter is visible in Unity Pro but not editable. ○ Hide: The parameter is not visible in Unity Pro but the value is sent to the device.
Bootup Procedure	The goal of bootup procedure tab is to bypass the standard bootup procedure for devices which do not comply with CANopen standards
Object Dictionary	The object dictionary screen is a CANopen Expert editor, and allows to: <ul style="list-style-type: none"> ● Force parameters to be transmitted even if they are unchanged. ● Suppress parameters that do not need to be sent to the device. ● Set objects to a specific value just before (prologue), or just after (epilogue) the standard bootup procedure. ● Modify the current value of an object (except read only objects).
EDS	The EDS tab displays in read-only mode the content of the EDS used to build the device.

The following table describes the procedure to add a device to the Catalog Manager.

Step	Action
1	Open the Catalog Manager.
2	<ul style="list-style-type: none"> ● Select Edit → Add Device Or ● Right-click a device family. ● Select 'Add Device'
3	A windows dialog box appears to select the EDS or DCF file to import:
4	<ul style="list-style-type: none"> ● Select the EDS or DCF file name corresponding to the device that is to be added ● Enter a unique name for the device (optional). <p>Only one EDS or DCF file can be selected at a time - multiple selections are not permitted. By default, the name of the EDS or DCF file is used as device name although it can be modified. The device name cannot be changed after this step.</p>
5	A screen appears showing the new device parameters. In this tab, you can sort the objects in different ways: either clicking the column head or selecting the checkboxes then clicking the column head again.
6	<p>Some parameters on the device profile screen can be changed by the user:</p> <ul style="list-style-type: none"> ● Family: Select the device family from the list. ● Image File: Select the image file (BMP or JPG format) associated to the device which will be displayed in the graphical Catalog Manager Configurator Editor. There is no limit to the size of the image. In the boxes included in the label zone, you define the device name position compared to the bitmap position. ● Expert Mode: Expert Mode Configuration Parameters. <p>When all configuration parameters are set as required, click OK.</p>
7	<p>Return to the Catalog Manager main screen and click the button 'Build Catalog' in order to save any changes, and to load the new device into the Catalog Manager database. A window appears showing the progress of the catalog build.</p> <p style="text-align: right;">  icon. </p>

The table below shows the procedure to add a function and access the configuration screen:

Step	Action
1	Open the Catalog Manager.
2	<p>There are different ways to access the configuration screen:</p> <ul style="list-style-type: none"> ● Right-click a device. Select 'Add Function" OR ● Select a device in the Catalog Manager. Select Edit → Add Function
3	A windows dialog box appears showing the basic configuration parameters.
4	<p>When configuration is complete, click OK. Return to the Catalog Manager main screen and click the button 'Build Catalog' in order to save any changes and to load the new function into the Catalog Manager database.</p>

The table below shows the procedure to close the Catalog Manager:

Step	Action
1	<p>Verify that your changes have been saved:</p> <ul style="list-style-type: none"> ● If there are changes, click Build Catalog. A window appears showing the progress of the catalog build. When the build is complete, go to the next step ● If there are not any changes, go to the next step.
2	<p>Select File → Exit</p> <p>OR</p> <p>Select Close on the main windows.</p>

Motion Function Block (MFB)

The MFB is a library which provides EFBs to easily control the axis of drive and motion devices connected to CANopen master. For more details, refer the MFB block in Unity Pro Help > EF/EFB/DFB Libraries > Motion Function Blocks.

System Bits and Words

Description

MC80 supports the following system words dedicated to communication functions. Some of them already exist on previous Premium or Quantum ranges but they are re-used with other semantic (highlighted in Bold).

%S	Bit	Function	Unity Rd/Wr
0	-	Cold-start Normally at 0, this bit is set on 1 by: <ul style="list-style-type: none"> ● Reset button ● the user program This bit is set to 1 during the first complete restored cycle of the PLC either in RUN or in STOP mode. It is reset to 0 by the system before the following cycle. To detect the first cycle in run after cold start, refer to %SW10.	Rd/Wr
1	-	Warm-start Normally at 0, this bit is set to 1 by: <ul style="list-style-type: none"> ● power is restored with data save ● the user program It is reset to 0 by the system at the end of the first complete cycle and before the outputs are updated.	Rd/Wr
4	-	Timebase 10 ms An internal timer regulates the change in status of this bit. It is asynchronous in relation to the PLC cycle.	Rd
5	-	Timebase 100 ms	Rd
6	-	Timebase 1 sec	Rd
7	-	Timebase 1 min	Rd
10	-	Global I/O detected error Normally at 1, this bit is set to 0 when an error on the embedded I/O or device on a network is detected (e.g. non-compliant configuration, exchange fault, hardware fault, etc.). The %S10 bit is reset to 1 by the system when all the detected errors have disappeared.	Rd
11	-	Watchdog overflow Normally at 0, this is set to 1 by the system as soon as the task execution time becomes greater than the maximum execution time (i.e., the watchdog) declared in the task properties.	Rd/Wr
12	-	PLC running This bit is set to 1 by the system when the PLC is in RUN. It is set to 0 by the system as soon as the PLC is no longer in RUN (STOP, INIT, etc.).	Rd
13	-	1st scan in RUN First cycle after switching to RUN. Switching the PLC from STOP mode to RUN mode (including after a cold start with automatic start in run) is indicated by setting system bit %S13 to 1. This bit is reset to 0 at the end of the first cycle of the MAST task in RUN mode	Rd
15	-	Character string error Normally set to 0, this bit is set to 1 when the destination zone for a character string transfer is not of sufficient size (including the number of characters and the end of string character) to receive this character string. The application stops in error state if the %S78 bit is to set to 1. This bit must be reset to 0 by the application.	Rd
16	-	Task I/O error Normally set to 1, this bit is set to 0 by the system when a fault on an in-rack module is detected (For example, non-compliant configuration, exchange fault, hardware fault, etc.). This bit must be set to 1 by the user.	Rd/Wr
17	-	Capacity overrun/carry Rotate shift output Normally at 0. During a rotate shift operation, this bit takes the state of the outgoing bit.	Rd/Wr

%S	Bit	Function	Unity Rd/Wr
18	-	<p>Overflow or arithmetic error</p> <p>Normally set to 0, this bit is set to 1 in the event of a capacity overflow if there is:</p> <ul style="list-style-type: none"> ● a result greater than + 32 767 or less than - 32 768, in integer (INT) ● a result greater than + 65 535 or less than 0, in unsigned integer (UINT) ● a result greater than + 2 147 483 647 or less than - 2 147 483 648, in double integer (DINT) ● a result greater than +4 294 967 295 or less than 0, in double unsigned integer (UDINT) ● real values outside limits ● division by 0 ● the root of a negative number ● stacking up of an already full register, emptying of an already empty register. 	Rd/Wr
19	-	<p>Task period overrun (periodical scanning)</p> <p>Normally set to 0, this bit is set to 1 by the system in the event of a time period overrun (i.e., task execution time is greater than the period defined by the user in the configuration or programmed into the %SW word associated with the task). The user must reset this bit to 0. Each task manages its own %S19 bit.</p>	Rd/Wr
20	-	<p>Index overflow</p> <p>Normally set to 0, this bit is set to 1 when the address of the indexed object becomes less than 0 or exceeds the number of objects declared in the configuration. In this case, it is as if the index were equal to 0.</p> <p>Test the user program after each operation where overflow may occur, then reset to 0 if there is indeed an overflow.</p> <p>When the %S20 bit switches to 1, the application stops in error state if the %S78 bit has been to set to 1.</p>	Rd/Wr
21	-	<p>1st task scan in RUN</p> <p>The bit %S21 indicates the first cycle of MAST task, including after a cold start with automatic start in run and a warm start.</p> <p>%S21 is set to 1 at the start of the cycle and reset to zero at the end of the cycle.</p>	
30	-	<p>Activation/deactivation of the master task</p> <p>Normally set to 1. The master task is deactivated when the user sets the bit to 0. This bit is taken into consideration by the system at the end of each MAST task cycle.</p>	Rd/Wr
40	-	<p>Local input/output fault</p> <p>The %S40 bit is assigned to rack 0.</p> <p>Normally set to 1, this bit is set to 0 when a fault occurs on the rack's I/Os. In this case:</p> <ul style="list-style-type: none"> ● the %S10 bit is set to 0 ● the I/O processor LED is on ● the %I.r.m.c.Err module bit is set to 1 ● this bit is reset to 1 when the fault disappears 	Rd
50	-	<p>Updating of time and date via words %SW50...%SW53</p> <p>Normally set to 0, this bit is set to 1 or 0 by the program or the terminal.</p> <ul style="list-style-type: none"> ● set to 0: update of system words %SW50...%SW53 by the date and time supplied by the PLC real-time clock ● set to 1: system words %SW50...%SW53 are no longer updated, therefore making it possible to modify them <p>The switch from 1 to 0 updates the real-time clock with the values entered in words %SW50...%SW53.</p>	Rd/Wr
51	-	<p>Time loss in real-time clock</p> <p>The system-managed bit set to 1 indicates that the real-time clock is missing or that its system words (%SW50...%SW53) are meaningless. In this case, the clock must be reset to the correct time.</p>	Rd
59	-	<p>Incremental update of the time and date via word %SW59</p> <p>Normally set to 0, this bit can be set to 1 or 0 by the program or the terminal:</p> <ul style="list-style-type: none"> ● set to 0: the system does not manage the system word %SW59 ● set to 1: the system manages edges on word %SW59 to adjust the date and current time (by increment) 	Rd/Wr

%S	Bit	Function	Unity Rd/Wr
66	-	<p>Application backup</p> <p>This bit is set to 1 by the user to start a backup operation. The system will detect the rising edge to start the backup. The state of this bit is polled by the system every second. A backup takes place only if the application in RAM is different from the one in the flash.</p> <p>This bit is set to 0 by the system when the backup is finished.</p> <p>Warning: Before creating a new backup by setting bit %S66 to 1, you must test that bit %S66 has been set to 0 by the system (which means the previous backup is finished). Never use %S66 if it is set to 1. This may lead to a loss of data.</p> <p>Bit %S66 is particularly useful after replacement of initial value %S94 and save parameters.</p>	Rd/Wr
78	-	<p>Stop in the event of error</p> <p>Normally at 0, this bit can be set to 1 by the user, to program a PLC stop on application fault: %S15, %S18, %20.</p>	Rd/Wr
80	-	<p>Reset message counters</p> <p>Normally set to 0, this bit can be set to 1 to reset the message counters %SW80 to %SW86.</p>	Rd/Wr
94	-	<p>Saving adjustment values</p> <p>Normally at 0, this bit can be set to 1 by the user to replace the initial values of the declared variables with a 'Save' attribute (For example, DFB variables) with the current values.</p> <p>The system resets the bit %S94 to 0 when the replacement is made.</p> <p>NOTE: This bit must be used with care: do not set this bit permanently to 1 and use the master task only.</p>	Rd/Wr
97	-	<p>Backup program OK</p> <p>This bit compares the application as executed in RAM versus the internal backup saved to flash. Values are:</p> <p>0: application backup not consistent. This state is obtained when application is auto modified (saveparam or replace init value) and not saved using %S66.</p> <p>1: application backup is consistent</p>	Rd/Wr
116	-	<p>global Ethernet port status</p> <p>0: both Ethernet port link down</p> <p>1: at least one port link up</p>	Rd
118	-	<p>CanOpen IO errors</p> <p>Normally at 1, this bit is at 0 on detection of a fault in a device on CANopen</p>	Rd

%SW	Bit	Function	Rd/Wr
0	-	<p>Master task scanning period</p> <p>This word is used to modify the period of the master task via the user program or via the terminal.</p> <p>The period is expressed in ms (1...255 ms) %SW0=0 in cyclic operation.</p> <p>On a cold restart: it takes the value defined by the configuration.</p>	Rd/Wr
6	-	IP Address LOW	Rd
7	-	IP Address HIGH	Rd
10	-	<p>Task init First cycle after cold start</p> <p>If the value of the current task bit is set to 0, it means that the task is performing its first cycle after a cold start.</p> <ul style="list-style-type: none"> ● %SW10.0: assigned to the MAST task. 	Rd
11	-	<p>Watchdog duration</p> <p>Reads the duration of the watchdog. The duration is expressed in milliseconds (10...1500 ms).</p> <p>This word cannot be modified.</p>	Rd
12	-	<p>Modbus slave address for terminal port</p> <p>Gives the Modbus slave address of the CPU serial port. Modification is not taken into account. it is 0 if the CPU does not have a Serial Port link.</p>	Rd
14	-	<p>Commercial version of PLC processor</p> <p>This word contains the current Operating System (OS) version of the PLC processor.</p> <p>Example: 16#0135</p> <p>version: 01</p> <p>issue number: 35</p>	Rd

%SW	Bit	Function	Rd/Wr
15	-	<p>PLC processor patch version</p> <p>This word contains the commercial version of the PLC processor patch. It is coded onto the least significant byte of the word.</p> <p>Coding: 0 = no patch, 1 = A, 2 = B...</p> <p>Example: 16#0003 corresponds to patch C.</p>	Rd
16	-	<p>Firmware version number</p> <p>This word contains the Firmware version number in hexadecimal of the PLC processor firmware.</p> <p>Example: 16#0011 version: 2.1 VN: 17</p>	Rd
17	-	<p>Error status on floating operation</p> <p>When an error in a floating arithmetic operation is detected, bit %S18 is set to 1 and %SW17 error status is updated according to the following coding:</p> <ul style="list-style-type: none"> ● %SW17.0 = Invalid operation / result is not a number ● %SW17.1 = Denormalized operand / result is acceptable (flag not managed by Modicon M340 or Quantum Safety PLCs) ● %SW17.2 = Division by 0 / result is infinity ● %SW17.3 = Overflow / result is infinity ● %SW17.4 = Underflow / result is 0 ● %SW17.5 to 15 = not used <p>This word is reset to 0 by the system on cold start, and also by the program for re-usage purposes.</p>	Rd/Wr
18, 19	-	<p>Absolute time counter</p> <p>%SW18 represents the least significant bytes and %SW19 the most significant bytes of the double word %SD18, which is incremented by the system every 1/10th of a second. The application can read or write these words in order to perform duration calculations.</p> <p>%SD18 is incremented systematically, even in STOP mode and equivalent states. However, times when the PLC is switched off are not taken into account, since the function is not linked to the real-time scheduler, but only to the real-time clock.</p> <p>For Quantum safety PLC, knowing that the 2 processors must process exactly the same data, the value of %SD18 is updated at the beginning of the mast task, and then frozen during the application execution.</p>	Rd/Wr
20	-	1 ms counter low	Rd
21	-	1 ms counter high	Rd
23	-	Rotary switch value	Rd
	7...0	Rotary switch value(Ethernet role name)	Rd
	8	Rotary switch change since power up	Rd
	9	Rotary switch error	Rd
26	-	<p>Number of requests processed</p> <p>This system word allows to verify on server side the number of requests processed by PLC per second.</p>	Rd/Wr
27, 28, 29	-	<p>System overhead time</p> <ul style="list-style-type: none"> ● %SW27 is the last system overhead time. ● %SW28 contains the maximum system overhead time. ● %SW29 contains the minimum system overhead time. <p>The system overhead time depends on the configuration (number of I/O) and on the current cycle requests (communication, diagnostics).</p> <p>System overhead time = Mast Cycle Time - User code execution time.</p> <p>This can be read and written by the user program or by the terminal.</p>	Rd/Wr
30	-	<p>Master task execution time</p> <p>This word indicates the execution time of the last master task cycle (in ms).</p>	Rd/Wr
31	-	<p>Maximum master task execution time</p> <p>This word indicates the longest master task execution time since the last cold start (in ms).</p>	Rd/Wr
32	-	<p>Minimum master task execution time</p> <p>This word indicates the shortest master task execution time since the last cold start (in ms).</p>	Rd/Wr

%SW	Bit	Function	Rd/Wr
49...53	-	<p>Real-time clock function System words containing date and current time (in BCD):</p> <ul style="list-style-type: none"> ● %SW49: day of the week: <ul style="list-style-type: none"> ○ 1 = Monday ○ 2 = Tuesday ○ 3 = Wednesday ○ 4 = Thursday ○ 5 = Friday ○ 6 = Saturday ○ 7 = Sunday ● %SW50: Seconds (16#SS00) ● %SW51: Hours and Minutes (16#HHMM) ● %SW52: Month and Day (16#MMDD) ● %SW53: Year (16#YYYY) <p>These words are managed by the system when the bit %S50 is set to 0. These words can be written by the user program or by the terminal when the bit %S50 is set to 1. For M580: The current time is in UTC (Coordinated Universal Time). If a local time is needed, use the RRTC_DT function.</p>	Rd/Wr
54...58	-	<p>Real-time clock function on last stop System words containing date and time of the last power failure or PLC stop (in Binary Coded Decimal):</p> <ul style="list-style-type: none"> ● %SW54: Seconds (00SS) ● %SW55: Hours and Minutes (HHMM) ● %SW56: Month and Day (MMDD) ● %SW57: Year (YYYY) ● %SW58: the most significant byte contains the day of the week (1 for Monday through to 7 for Sunday), and the least significant byte contains the code for the last stop: <ul style="list-style-type: none"> ○ 1 = change from RUN to STOP by the terminal or the dedicated input ○ 2 = stop by watchdog (PLC task or SFC overrun) ○ 4 = power outage or memory card lock operation ○ 5 = stop on hardware fault ○ 6 = stop on software fault. Details on the type of software fault are stored in %SW125 	Rd
59	-	<p>Adjustment of current date Contains two 8-bit series to adjust the current date. The action is always performed on the rising edge of the bit. This word is enabled by bit %S59=1.</p>	Rd/Wr
70	-	<p>Week of year System word containing the number of the week in the year: 1...52 (in BCD).</p>	Rd
76	-	<p>Diagnostics function: recording Result of the last registration = 0 if the recording was successful = 1 if the diagnostics buffer has not been configured = 2 if the diagnostics buffer is full</p>	Rd/Wr
77	-	<p>Diagnostics function: non-recording Result of the last de-registration = 0 if the non-recording was successful = 1 if the diagnostics buffer has not been configured = 21 if the error identifier is invalid = 22 if the error has not been recorded</p>	Rd/Wr
78	-	<p>Diagnostics function: number of errors Number of errors currently in the diagnostics buffer.</p>	Rd
80, 81	-	<p>Message management These words are updated by the system, and can also be reset using %S80.</p> <ul style="list-style-type: none"> ● %SW80: Number of message sent by the system to the terminal port (Modbus serial port) ● %SW81: Number of message received by the system to the terminal port (Modbus serial port). 	Rd

%SW	Bit	Function	Rd/Wr
84, 85	-	<p>Message send to USB</p> <p>These words are updated by the system, and can also be reset using %S80.</p> <ul style="list-style-type: none"> ● %SW84: Number of messages sent to the USB port ● %SW85: Number of messages received by the USB port. 	Rd
86	-	<p>Modbus exception messages</p> <p>This word is updated by the system, and can also be reset using %S80.</p> <ul style="list-style-type: none"> ● Number of messages refused by the system, not treated because of lack of resources for example. If the message is refused by Modbus Server then it corresponds to Modbus exception messages, sent by the CPU to the remote Modbus client. 	
87	-	<p>Communication flow management</p> <p>Number of requests processed by synchronous server per master (MAST) task cycle. The requests processed may come from all communication ports.</p>	
90	-	<p>Maximum number of requests processed per master task cycle</p> <p>N=4(minimum 2, maximum 4 + 4 = 8)</p>	Rd/Wr
94, 95	-	<p>Application modification signature</p> <p>These two words contain a 32-bit value that changes at every application modification except when:</p> <ul style="list-style-type: none"> ● updating upload information ● replacing the initial value with the current value ● saving the parameter command 	Rd
96	-	<p>Command and Diagnostic of Save and Restore</p>	Rd/Wr
108	-	<p>Forced bit counting status register</p> <p>Word %SW108:</p> <ul style="list-style-type: none"> ● increments each time an discrete bit (%I,%Q or %M) is forced ● decrements each time an discrete bit is unforced 	Rd
124	-	<p>Type of processor or system error</p> <p>The last type of system fault encountered is written into this word by the system (these codes are unchanged on a cold restart):</p> <ul style="list-style-type: none"> ● 16#30: system code fault ● 16#53: time-out fault during I/O exchanges ● 16#60 to 64: stack overrun ● 16#65: Fast task period of execution is too low ● 16#81: detection of backplane error <p>NOTE: If this error is detected, all racks have to be re-initialized.</p> <ul style="list-style-type: none"> ● 16#90: Detected Internal system error: Unexpected interruption 	Rd
125	-	<p>Last fault detected</p> <p>The code of the last fault detected is given in this word. The following error codes cause the PLC to stop if %S78 is set to 1.</p> <p>%S15, %S18 and %S20 are always activated independently of %S78:</p> <ul style="list-style-type: none"> ● 16#2258: execution of HALT instruction ● 16#DE87: calculation error on floating-point numbers (%S18, these errors are listed in the word %SW17) ● 16#DEB0: Watchdog overflow (%S11) ● 16#DEF0: division by 0 (%S18) ● 16#DEF1: character string transfer error (%S15) ● 16#DEF2: arithmetic error; %S18 ● 16#DEF3: index overflow (%S20) <p>NOTE: The following codes 16#8xF4, 16#9xF4, and -16#DEF7 indicate an error on Sequence Function Chart (SFC).</p>	Rd
126...127	-	<p>Blocking error instruction address</p> <p>Address of the instruction that generated the application blocking error.</p> <ul style="list-style-type: none"> ● %SW126 contains the least significant word for this address ● %SW127 contains the most significant word for this address <p>For a system STOP due a watchdog overflow:</p> <ul style="list-style-type: none"> ● %SW126 contains the number of the MAST task with the overflow ● %SW127 contains the value of the MAST task with the overflow 	Rd
128	-	<p>IP Netmask low</p>	Rd
129	-	<p>IP Netmask high</p>	Rd
130	-	<p>IP Gateway low</p>	Rd
131	-	<p>IP Gateway high</p>	Rd

%SW	Bit	Function	Rd/Wr
132	-	MAC address low	Rd
133	-	MAC address medium	Rd
134	-	MAC address high	Rd
135	-	FDR Client Status 0 = not initialized 1 = IP initialized 3= link ETH down 4= IP duplicate 5 = Wait for server 6= no conf or conf error 7= configuration conflict	Rd
136	-	RSTP status	Rd
	2...0	Eth port 1 RSTP port role (0=none, 1 = alternate , 2=backup, 3=root, 4= designated, 5=non-RSTP port)	Rd
	5...3	Eth port 2 RSTP port role	Rd
137	-	P502 opened connection nbr server mode	Rd
138	-	P502 opened connection nbr client mode	Rd
146	-	Communication status of Master	Rd
	1	= 1: FIFO full cause message lost	
	2	= 1: CAN controller BUS OFF	
	3	: Reserved	
	4	= 1: CAN controller is warning status	
	5	= 1: Overflow of the low priority emission queue. The CANopen Master transmits "Heartbeat" and "Node guarding" messages as well as SSDOs and CSDOs via the low priority transmission queue.	
	6	= 1: Overflow of the high priority reception queue. The CANopen Master receives RPDOs, NMT commands, the message Sync and emergency messages via the high priority reception queue.	
	7	= 1: Overflow of the high priority transmit queue. The CANopen Master sends TPDOs, NMT commands, the message Sync and emergency messages via the high priority queue.	
147	-	Status of CANopen Master	Rd
	-	= 0x00 INIT: The CANopen Master is not initialized. This corresponds to the INITIALISATION status of the CANopen module. In this state, the CANopen Master cannot communicate with the network.	
	-	= 0x40 RESET: The CANopen Master is configured as master during NMT STARTUP. The object dictionary of CANopen Master can be configured by SDOs via the CAN bus and the interface of the SDO command. The application has read/write access rights to the object	
	-	= 0x60 NET INIT: Start-up according to CIA DSP-302. The CANopen Master checks the allocation of the slaves.	
	-	= 0x61 NET RESET: The network is re-initialized by the NMT command RESET COMMUNICATION ALL NODES.	
	-	= 0x62 NET WAIT: The CANopen Master waits (waiting time be defined) to allow the modules to run the command RESET COMMUNICATION.	
	-	= 0x64 BOOT CONF: The CANopen Master initializes modules according to CIA DSP-302 by scanning the network.	
	-	= 0x8x CLEAR: The network is scanned. The Master is waiting for a start command (START CANopen MASTER/MANAGER or START NETWORK).	
	-	= 0xAx RUN: The network is in the OPERATIONAL state.	
	-	= 0xCx STOP: The network is in the STOP state.	
	-	= 0Ex PREOPERATIONAL: The network is in the PREOPERATIONAL state.	
-	= 0x9x FATAL ERROR: The CANopen Master is inoperative and must be re-initialized.		

%SW	Bit	Function	Rd/Wr
148	-	Event indicator	Rd
	0	= 1: This bit is always set when a detected error has occurred in communication with the network. The communication status of CANOpen Master gives the exact reason. (The CANOpen Master is unable to run correctly and stops).	
	1	= 1: A module is using the node number of CANOpen Master. (The CANOpen Master is unable to run correctly and stops).	
	2...3	: Reserved	
	4	= 1: There is a detected identity error for an optional module. The boot slave process is repeated.	
	5...6	: Reserved.	
	7	= 1s: This bit is set if a bit in one of the bit lists changes.	
	8	= 1: At the beginning of the start-up procedure, the CANOpen Master checks the individual slave assignments. This bit is set by the slave assignment if a module that contain features which are not supported by the CANOpen Master (for example, bit 4 to bit	
	9	= 1: The CANOpen Master has received an RPDO with not enough data bytes. (The CANOpen Master does not change its state.)	
	10	= 1: Inconsistent or mismatch DCF bit.	
	11	: Reserved.	
	12	= 1: The last Master/Manager cycle time is greater than 256 ms.	
	13	= 1: The Master is the only CAN device on the network. It gets no acknowledgment to its transmitted frames. All nodes are marked as absent. The Master keeps its state until the ““alone”” situation is released.	
	14... 15	: Reserved	
149	-	Master Command Information	Rd/Wr
	2	: Reset bit 7 (change bit list) of event indicator (%SW148)	
	3	: Reset all the bus analysis information (%SW155...%SW159, %SW176...%SW177)	
	5	: Reset the CANOpen master	
150	-	SDO Abort code low	Rd/Wr
151	-	SDO Abort code high	Rd/Wr
152	-	CANOpen Node number	Rd/Wr
153	-	CANOpen Index	Rd/Wr
154	-	CANOpen Sub-index	Rd/Wr
155	-	CANOpen Error A: Number of bits erro	Rd/Wr
156	-	CANOpen Error B: Number of form error	Rd/Wr
157	-	CANOpen Error C: Number of stuff error	Rd/Wr
158	-	CANOpen Error D: Number of other errors	Rd/Wr
159	-	CANOpen Error E: Last error code capture register: this register contains information about type and location of errors on the bus	Rd/Wr
160	-	Local IO health bit 0: reserved bit 1: 0 in case of error on HSC, else 1 bit 2: 0 in case of error on DDM, else 1 bit 3: 0 in case of error on AMI, else 1	Rd/Wr
168	-	CANOpen List of Assigned but configured slaves	Rd
169	-	CANOpen List of Configured Slaves	Rd
170	-	CANOpen List of Slaves with configuration faults	Rd
171	-	CANOpen List of Inoperative Slaves	Rd
172	-	CANOpen List of Operational Slaves	Rd
173	-	CANOpen List of Stopped slaves	Rd
174	-	CANOpen List of Pre-operational slaves	Rd
175	-	Number of CANOpen transmitted messages	Rd
176	-	Number of CANOpen received messages	Rd
177	-	Current CANOpen master cycle time	Rd

%SW	Bit	Function	Rd/Wr
178	-	CANOpen master maximum execution time	Rd
179	-	CANOpen master minimum execution time	Rd
180	-	CANOpen master assigned cycle time	Rd/Wr
181	-	Ethernet Port 0 Rx Bad Frames Counter	Rd
182	-	Ethernet Port 0 Collisions Counter	Rd
183	-	Ethernet Port 0 In Filtered Counter	Rd
184	-	Ethernet Port 1 Rx Bad Frames Counter	Rd
185	-	Ethernet Port 1 Collisions Counter	Rd
186	-	Ethernet Port 1 In Filtered Counter	Rd
187	-	RSTP Topology Change Counter	Rd

Chapter 13

MC80 Firmware Upgrade

Firmware Upgrade

Description

The MC80 PLC Firmware upgrade is done using Unity Loader. The MC80 PLC provides a fast and reliable firmware upgrade from the Unity Loader to PLC through USB connection or through Ethernet connection. For upgrading, select the correct .idx file and then connect to the PLC.

NOTE:

- BMK C80 ***** processors have different .idx files.
- If an application is present before starting an upgrade then the CPU must be in stop mode. Stop command is available from Unity Loader.
- The Firmware upgrade cannot be performed with serial port connection.

Security Features

The Firmware Upgrade feature can be enabled or disabled in Unity Pro configuration. This feature is disabled in default state.

NOTE: Before upgrading, you have to change the Unity Pro configuration to enable the Firmware Upgrade feature.

The following describes the Firmware upgrade process:

- When FW upgrade process is started, the CPU enters a specific state where only the communication with Unity Loader is active and the state is shown by an LED combination.
- At the end of upgrade, the CPU will reboot with a new version and the application is stored in flash.
- In the stop mode, the CPU does a cold start and if the run option is checked, the application starts automatically.
- If there is an error during the FW upgrade (connection broken or power outage of CPU), the CPU must be reset and restarted with old OS.