

Modicon Controller Systems

Cybersecurity

User Guide

Original instructions

11/2023

EIO0000001999.11

Legal Information

The information provided in this document contains general descriptions, technical characteristics and/or recommendations related to products/solutions.

This document is not intended as a substitute for a detailed study or operational and site-specific development or schematic plan. It is not to be used for determining suitability or reliability of the products/solutions for specific user applications. It is the duty of any such user to perform or have any professional expert of its choice (integrator, specifier or the like) perform the appropriate and comprehensive risk analysis, evaluation and testing of the products/solutions with respect to the relevant specific application or use thereof.

The Schneider Electric brand and any trademarks of Schneider Electric SE and its subsidiaries referred to in this document are the property of Schneider Electric SE or its subsidiaries. All other brands may be trademarks of their respective owner.

This document and its content are protected under applicable copyright laws and provided for informative use only. No part of this document may be reproduced or transmitted in any form or by any means (electronic, mechanical, photocopying, recording, or otherwise), for any purpose, without the prior written permission of Schneider Electric.

Schneider Electric does not grant any right or license for commercial use of the document or its content, except for a non-exclusive and personal license to consult it on an "as is" basis.

Schneider Electric reserves the right to make changes or updates with respect to or in the content of this document or the format thereof, at any time without notice.

To the extent permitted by applicable law, no responsibility or liability is assumed by Schneider Electric and its subsidiaries for any errors or omissions in the informational content of this document, as well as any non-intended use or misuse of the content thereof.

Table of Contents

Safety Information	5
Before You Begin	6
Start-up and Test	7
Operation and Adjustments	8
About the Book	9
Presentation	16
Schneider Electric Guidelines	16
How to Help Secure the Architecture	18
System View	18
Setting Passwords in Control Expert	20
Hardening the PC	22
Disable Unused Embedded Communication Services	30
Restrict Data Flow from Control Network (Access Control)	31
Set Up Encrypted Communication	34
CSPN Security Target	40
Set Up Cybersecurity Audit (Event Logging)	48
Event Log Message Descriptions for Control Expert	56
Event Log Message Descriptions M580 Controllers (as of Firmware Version V4.10), and BMENOR2200H (as of Firmware Version 3.01)	62
Event Log Message Descriptions for M580 Controllers (Firmware earlier than Version 4.10), BMENUA0100 and BMENOR2200H (Firmware earlier than Version 3.01)	74
Control Identification and Authentication	89
Control Authorizations	93
Manage Data Integrity Checks	97
Configure a Secure Engineering Link between Control Expert and an M580 Ethernet Controller	99
Features of a Secure Connection	99
Configure a Secure Connection Procedure	102
Operating Mode Considerations	104
Enforced Secure Programming Compatibility and Limitations	105

Communication Adapter Compatibility	107
M580 Ethernet Services and Ports.....	112
Physical Port Connections	113
Cybersecurity Services Per System	114
Cybersecurity Services	114
Modicon M340 Security Services.....	120
Modicon M580 Security Services.....	121
Modicon Quantum Security Services	121
Modicon X80 Security Services	123
Modicon Premium/Atrium Security Services	125
How to help protect M580 and M340 architectures with EAGLE40 using	
VPN	127
EAGLE40 Firewall.....	127
Prerequisites	128
Typical Architecture	129
Configuring the Firewall	129
Glossary	137
Index.....	160

Safety Information

Important Information

Read these instructions carefully, and look at the equipment to become familiar with the device before trying to install, operate, service, or maintain it. The following special messages may appear throughout this documentation or on the equipment to warn of potential hazards or to call attention to information that clarifies or simplifies a procedure.



The addition of this symbol to a “Danger” or “Warning” safety label indicates that an electrical hazard exists which will result in personal injury if the instructions are not followed.



This is the safety alert symbol. It is used to alert you to potential personal injury hazards. Obey all safety messages that follow this symbol to avoid possible injury or death.

DANGER

DANGER indicates a hazardous situation which, if not avoided, **will result in** death or serious injury.

WARNING

WARNING indicates a hazardous situation which, if not avoided, **could result in** death or serious injury.

CAUTION

CAUTION indicates a hazardous situation which, if not avoided, **could result in** minor or moderate injury.

NOTICE

NOTICE is used to address practices not related to physical injury.

Please Note

Electrical equipment should be installed, operated, serviced, and maintained only by qualified personnel. No responsibility is assumed by Schneider Electric for any consequences arising out of the use of this material.

A qualified person is one who has skills and knowledge related to the construction and operation of electrical equipment and its installation, and has received safety training to recognize and avoid the hazards involved.

Before You Begin

Do not use this product on machinery lacking effective point-of-operation guarding. Lack of effective point-of-operation guarding on a machine can result in serious injury to the operator of that machine.

WARNING

UNGUARDED EQUIPMENT

- Do not use this software and related automation equipment on equipment which does not have point-of-operation protection.
- Do not reach into machinery during operation.

Failure to follow these instructions can result in death, serious injury, or equipment damage.

This automation equipment and related software is used to control a variety of industrial processes. The type or model of automation equipment suitable for each application will vary depending on factors such as the control function required, degree of protection required, production methods, unusual conditions, government regulations, etc. In some applications, more than one processor may be required, as when backup redundancy is needed.

Only you, the user, machine builder or system integrator can be aware of all the conditions and factors present during setup, operation, and maintenance of the machine and, therefore, can determine the automation equipment and the related safeties and interlocks which can be properly used. When selecting automation and control equipment and related software for a particular application, you should refer to the applicable local and national standards and regulations. The National Safety Council's Accident Prevention Manual (nationally recognized in the United States of America) also provides much useful information.

In some applications, such as packaging machinery, additional operator protection such as point-of-operation guarding must be provided. This is necessary if the operator's hands and

other parts of the body are free to enter the pinch points or other hazardous areas and serious injury can occur. Software products alone cannot protect an operator from injury. For this reason the software cannot be substituted for or take the place of point-of-operation protection.

Ensure that appropriate safeties and mechanical/electrical interlocks related to point-of-operation protection have been installed and are operational before placing the equipment into service. All interlocks and safeties related to point-of-operation protection must be coordinated with the related automation equipment and software programming.

NOTE: Coordination of safeties and mechanical/electrical interlocks for point-of-operation protection is outside the scope of the Function Block Library, System User Guide, or other implementation referenced in this documentation.

Start-up and Test

Before using electrical control and automation equipment for regular operation after installation, the system should be given a start-up test by qualified personnel to verify correct operation of the equipment. It is important that arrangements for such a check are made and that enough time is allowed to perform complete and satisfactory testing.

▲ WARNING

EQUIPMENT OPERATION HAZARD

- Verify that all installation and set up procedures have been completed.
- Before operational tests are performed, remove all blocks or other temporary holding means used for shipment from all component devices.
- Remove tools, meters, and debris from equipment.

Failure to follow these instructions can result in death, serious injury, or equipment damage.

Follow all start-up tests recommended in the equipment documentation. Store all equipment documentation for future references.

Software testing must be done in both simulated and real environments.

Verify that the completed system is free from all short circuits and temporary grounds that are not installed according to local regulations (according to the National Electrical Code in the U.S.A, for instance). If high-potential voltage testing is necessary, follow recommendations in equipment documentation to prevent accidental equipment damage.

Before energizing equipment:

- Remove tools, meters, and debris from equipment.

- Close the equipment enclosure door.
- Remove all temporary grounds from incoming power lines.
- Perform all start-up tests recommended by the manufacturer.

Operation and Adjustments

The following precautions are from the NEMA Standards Publication ICS 7.1-1995:

(In case of divergence or contradiction between any translation and the English original, the original text in the English language will prevail.)

- Regardless of the care exercised in the design and manufacture of equipment or in the selection and ratings of components, there are hazards that can be encountered if such equipment is improperly operated.
- It is sometimes possible to misadjust the equipment and thus produce unsatisfactory or unsafe operation. Always use the manufacturer's instructions as a guide for functional adjustments. Personnel who have access to these adjustments should be familiar with the equipment manufacturer's instructions and the machinery used with the electrical equipment.
- Only those operational adjustments required by the operator should be accessible to the operator. Access to other controls should be restricted to prevent unauthorized changes in operating characteristics.

About the Book

Document Scope

This manual defines the cybersecurity elements that help you configure a system that is less susceptible to cyber attacks.

NOTE: The terms ‘security’, ‘secure’, ‘secured’, ‘securing’ are used throughout this document in reference to cybersecurity topics.

Validity Note

This document has been updated for EcoStruxure™ Control Expert V16.0.

For product compliance and environmental information (RoHS, REACH, PEP, EOLI, etc.), go to www.se.com/ww/en/work/support/green-premium/.

Available Languages of this Document

This document is available in these languages:

- Chinese (EIO0000002004)
- English (EIO0000001999)
- French (EIO0000002001)
- German (EIO0000002000)
- Italian (EIO0000002002)
- Spanish (EIO0000002003)

Information Related to Cybersecurity

Information on cybersecurity is provided on the Schneider Electric website: <http://www2.schneider-electric.com/sites/corporate/en/support/cybersecurity/cybersecurity.page>

Document available for download in the cybersecurity support section:

Title of Documentation	Webpage Address
How can I ... Reduce Vulnerability to Cyber Attacks? System Technical Note, Cybersecurity Recommendations	www.se.com/ww/en/download/document/STN v2

Related Documents

Title of Documentation	Reference Number
Modicon M580 System Planning Guide	HRB62666 (English), HRB65318 (French), HRB65319 (German), HRB65320 (Italian), HRB65321 (Spanish), HRB65322 (Chinese)
Modicon M580 Hardware Reference Manual	EIO0000001578 (English), EIO0000001579 (French), EIO0000001580 (German), EIO0000001582 (Italian), EIO0000001581 (Spanish), EIO0000001583 (Chinese)
Modicon M580 BMENOC0301/0311, Ethernet Communications Module, Installation and Configuration Guide	HRB62665 (English), HRB65311 (French), HRB65313 (German), HRB65314 (Italian), HRB65315 (Spanish), HRB65316 (Chinese)
Modicon M340 for Ethernet, Communications Modules and Processors, User Manual	31007131 (English), 31007132 (French), 31007133 (German), 31007494 (Italian), 31007134 (Spanish), 31007493 (Chinese)
Quantum using EcoStruxure™ Control Expert, TCP/IP Configuration, User Manual	33002467 (English), 33002468 (French), 33002469 (German), 31008078 (Italian), 33002470 (Spanish), 31007110 (Chinese)
Premium and Atrium using EcoStruxure™ Control Expert, Ethernet Network Modules, User Manual	35006192 (English), 35006193 (French), 35006194 (German), 31007214 (Italian), 35006195 (Spanish), 31007102 (Chinese)
EcoStruxure™ Control Expert, Operating Modes	33003101 (ENG) 33003102 (FRE) 33003103 (GER) 33003104 (SPA) 33003696 (ITA) 33003697 (CHS)
Quantum using EcoStruxure™ Control Expert, Hardware Reference Manual	35010529 (English), 35010530 (French), 35010531 (German), 35013975 (Italian), 35010532 (Spanish), 35012184 (Chinese)
Quantum using EcoStruxure™ Control Expert, 140NOC77101, Ethernet Communication Module, User Manual	S1A33985 (ENG) S1A33986 (FRE) S1A33987 (GER) S1A33989 (ITA) S1A33988 (SPA) S1A33993 (CHS).
Premium using EcoStruxure™ Control Expert, TSXETC101, Ethernet Communication Module, User Manual	S1A34003 (ENG) S1A34004 (FRE) S1A34005 (GER) S1A34007 (ITA) S1A34006 (SPA) S1A34008 (CHS)
Modicon M340, BMXNOC0401 Ethernet Communication Module, User Manual	S1A34009 (English), S1A34010 (French), S1A34011 (German), S1A34013 (Italian), S1A34012 (Spanish), S1A34014 (Chinese)

Title of Documentation	Reference Number
Quantum EIO, Control Network, Installation and Configuration Guide	S1A48993 (English), S1A48994 (French), S1A48995 (German), S1A48997 (Italian), S1A48998 (Spanish), S1A48999 (Chinese)
EcoStruxure™ Control Expert, Communication, Block Library	33002527 (English), 33002528 (French), 33002529 (German), 33003682 (Italian), 33002530 (Spanish), 33003683 (Chinese)
Quantum using EcoStruxure™ Control Expert, Ethernet Network Modules, User Manual	33002479 (English), 33002480 (French), 33002481 (German), 31007213 (Italian), 33002482 (Spanish), 31007112 (Chinese)
Modicon M580 BME CXM CANopen Modules, User Manual	EIO0000002129 (English), EIO0000002130 (French), EIO0000002131 (German), EIO0000002132 (Italian), EIO0000002133 (Spanish), EIO0000002134 (Chinese)
MC80 Programmable Logic Controller, User Manual	EIO0000002071 (English)
EcoStruxure Automation Device Maintenance Firmware Upgrade Tool	EIO0000004033 (English), EIO0000004046 (German), EIO0000004047 (Spanish), EIO0000004048 (French), EIO0000004049 (Italian), EIO0000004050 (Chinese)

Product Related Information

▲ WARNING

LOSS OF CONTROL

- Perform a Failure Mode and Effects Analysis (FMEA), or equivalent risk analysis, of your application, and apply preventive and detective controls before implementation.
- Provide a fallback state for undesired control events or sequences.
- Provide separate or redundant control paths wherever required.
- Supply appropriate parameters, particularly for limits.
- Review the implications of transmission delays and take actions to mitigate them.
- Review the implications of communication link interruptions and take actions to mitigate them.
- Provide independent paths for control functions (for example, emergency stop, over-limit conditions, and error conditions) according to your risk assessment, and applicable codes and regulations.
- Apply local accident prevention and safety regulations and guidelines.¹
- Test each implementation of a system for proper operation before placing it into service.

Failure to follow these instructions can result in death, serious injury, or equipment damage.

¹ For additional information, refer to NEMA ICS 1.1 (latest edition), *Safety Guidelines for the Application, Installation, and Maintenance of Solid State Control* and to NEMA ICS 7.1 (latest edition), *Safety Standards for Construction and Guide for Selection, Installation and Operation of Adjustable-Speed Drive Systems* or their equivalent governing your particular location.

▲ WARNING

UNINTENDED EQUIPMENT OPERATION

- Only use software approved by Schneider Electric for use with this equipment.
- Update your application program every time you change the physical hardware configuration.

Failure to follow these instructions can result in death, serious injury, or equipment damage.

⚠ WARNING

UNINTENDED EQUIPMENT OPERATION, LOSS OF CONTROL, LOSS OF DATA

You, and anyone owning, designing, operating and/or maintaining equipment using EcoStruxure Control Expert, must read, understand, and follow the instructions outlined in the present document.

Failure to follow these instructions can result in death, serious injury, or equipment damage.

Information on Non-Inclusive or Insensitive Terminology

As a responsible, inclusive company, Schneider Electric is constantly updating its communications and products that contain non-inclusive or insensitive terminology. However, despite these efforts, our content may still contain terms that are deemed inappropriate by some customers.

Terminology Derived from Standards

The technical terms, terminology, symbols and the corresponding descriptions in the information contained herein, or that appear in or on the products themselves, are generally derived from the terms or definitions of international standards.

In the area of functional safety systems, drives and general automation, this may include, but is not limited to, terms such as *safety*, *safety function*, *safe state*, *fault*, *fault reset*, *malfunction*, *failure*, *error*, *error message*, *dangerous*, etc.

Among others, these standards include:

Standard	Description
IEC 61131-2:2007	Programmable controllers, part 2: Equipment requirements and tests.
ISO 13849-1:2023	Safety of machinery: Safety related parts of control systems. General principles for design.
EN 61496-1:2013	Safety of machinery: Electro-sensitive protective equipment. Part 1: General requirements and tests.
ISO 12100:2010	Safety of machinery - General principles for design - Risk assessment and risk reduction
EN 60204-1:2006	Safety of machinery - Electrical equipment of machines - Part 1: General requirements
ISO 14119:2013	Safety of machinery - Interlocking devices associated with guards - Principles for design and selection
ISO 13850:2015	Safety of machinery - Emergency stop - Principles for design
IEC 62061:2021	Safety of machinery - Functional safety of safety-related electrical, electronic, and electronic programmable control systems
IEC 61508-1:2010	Functional safety of electrical/electronic/programmable electronic safety-related systems: General requirements.
IEC 61508-2:2010	Functional safety of electrical/electronic/programmable electronic safety-related systems: Requirements for electrical/electronic/programmable electronic safety-related systems.
IEC 61508-3:2010	Functional safety of electrical/electronic/programmable electronic safety-related systems: Software requirements.
IEC 61784-3:2021	Industrial communication networks - Profiles - Part 3: Functional safety fieldbuses - General rules and profile definitions.
2006/42/EC	Machinery Directive
2014/30/EU	Electromagnetic Compatibility Directive
2014/35/EU	Low Voltage Directive

In addition, terms used in the present document may tangentially be used as they are derived from other standards such as:

Standard	Description
IEC 60034 series	Rotating electrical machines
IEC 61800 series	Adjustable speed electrical power drive systems
IEC 61158 series	Digital data communications for measurement and control – Fieldbus for use in industrial control systems

Finally, the term zone of operation may be used in conjunction with the description of specific hazards, and is defined as it is for a hazard zone or danger zone in the Machinery Directive (2006/42/EC) and ISO 12100:2010.

NOTE: The aforementioned standards may or may not apply to the specific products cited in the present documentation. For more information concerning the individual standards applicable to the products described herein, see the characteristics tables for those product references.

Presentation

Introduction

The goal of this book is to present the cybersecurity solutions implemented in Modicon controllers and associated software applications. In addition to the solutions presented in this book, apply the guidelines provided in Schneider Electric cybersecurity technical notes available on the [Schneider Electric website](#).

Schneider Electric Guidelines

Introduction

Your PC system can run various applications to help enhance security in your control environment. The system has factory default settings that require re-configuration to align with Schneider Electric device hardening guidelines of the defense-in-depth approach.

A topic dedicated to cybersecurity is available in the support area of the [Schneider Electric website](#).

Defense-In-Depth Approach

In addition to the solutions presented in the present document, follow the Schneider Electric defense-in-depth approach as described in the following documents:

- **Book title:** How can I ... Reduce Vulnerability to Cyber Attacks? System Technical Note, Cybersecurity Recommendations
- **Website link description (book description):** How Can I Reduce Vulnerability to Cyber Attacks in PlantStruxure Architectures?

Managing Vulnerabilities

Reported vulnerabilities from Schneider Electric devices are documented in the **Cybersecurity support** web page at <http://www2.schneider-electric.com/sites/corporate/en/support/cybersecurity/cybersecurity.page>.

A list of security notifications can be accessed by clicking **Security Notifications** which takes you to: <https://www.se.com/ww/en/work/support/cybersecurity/security-notifications.jsp>.

If you face a cybersecurity incident or vulnerability not mentioned in the list provided by Schneider Electric, you can report this incident or vulnerability by clicking **Report a Vulnerability** on the **Cybersecurity support** web page to open: <https://www.se.com/ww/en/work/support/cybersecurity/report-a-vulnerability.jsp>

How to Help Secure the Architecture

Introduction

This chapter describes how to help make Modicon controllers more secure.

System View

System Architecture

The following architecture highlights the necessity to have a multi-layered architecture (with a control network and a device network) that can be more secured. A flat architecture (all equipment connected to the same network) cannot be secured properly.

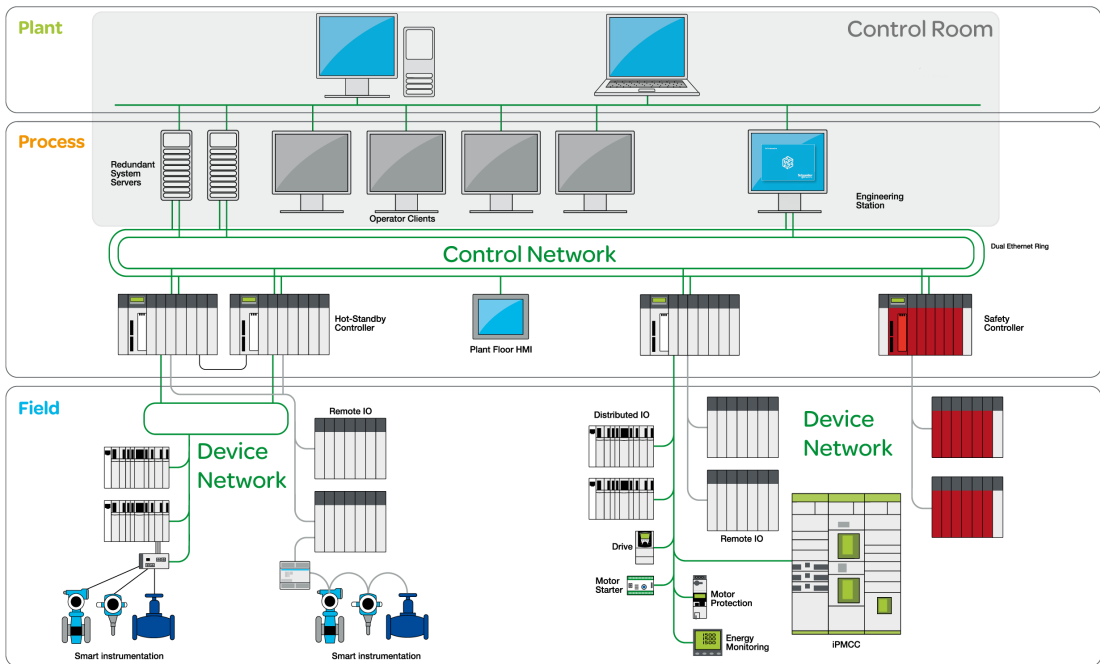

More Secured Communication

Equipment in the control room is more exposed to attacks than equipment connected to the device network. Therefore, implement more secured communication between the control room and the controller and devices. Isolate the device network from the other network levels (such as control networks and remote networks).

In the system architecture above, the control room area is grayed to distinguish it from the controller and other devices.

More Secured Access to the USB Ports

Physical access to the USB ports needs to be controlled.

NOTE: Securing the USB ports can only be done by physical means (for example cabinet or physical key).

More Secured Access to the Hot Standby Link and Device Network

Control the physical access to the Hot Standby link and to the device network.

Testing

Control Expert provides a simulator to test your application before commissioning it as part of your industrial automation system. The simulator conforms to the cybersecurity requirements that:

- The simulator can be operated only with an application open in Control Expert.
- The application open in the simulator cannot be uploaded from the simulator to the controller.

For information on how to operate the simulator, refer to the help for the *EcoStruxure™ Control Expert, Controller Simulator* (<https://youtu.be/RrkorSe0G8s>).

Setting Passwords in Control Expert

Use Control Expert software to set passwords that help secure your project. The following passwords can be set:

- Application password, with or without file encryption
- Safety-related area password
- Firmware upgrade password
- Program unit, section, and subroutine password
- Data storage/web password

Application Password

Control Expert provides a password mechanism to help guard against unauthorized access to the application. Control Expert uses the password when you:

- Open the application in Control Expert.
- Connect to the controller in Control Expert.

Application protection by a password helps prevent unwanted application modification, download, or opening of application files. The password is stored encrypted in the application.

In addition to the password protection you can encrypt the .STU, .STA and .ZEF files. The file encryption feature in Control Expert helps prevent unauthorized modifications by unqualified personnel and reinforces protection against theft of intellectual property and other malicious intentions. The file encryption option is protected by a password mechanism.

NOTE: When a controller is managed as part of a system project, the application password and file encryption are disabled in the Control Expert editor and need to be managed by using the Topology Manager.

For information on how to set and use application passwords, refer to the *Application Protection* topic in the *EcoStruxure™ Control Expert, Operating Modes* manual.

Safety-Related Area Password

Safety controllers include a safety-related area password protection function, which is accessible from the **Properties** screen of the project. This function is used to help protect project elements located within the safety-related area of the functional safety project.

When the safety-related area password protection function is active, the safety-related parts of the application cannot be modified.

For information on how to set and use safety-related area passwords, refer to the *Safety-related Area Password Protection* topic in the *EcoStruxure™ Control Expert, Operating Modes* manual

).

Firmware Update Password

Firmware protection by a password helps prevent unwanted access to the module firmware.

For M580 controllers, management of the firmware updates depends on the controller firmware version used to create the application.

- For controller firmware versions earlier than 4.01:
 - Firmware update is managed using FTP.
 - Firmware update access Storage access *can* be password protected.
- For controller firmware versions 4.01 and later:
 - Firmware update access is managed using HTTPS (more secure than FTP).
 - Firmware update access *must* be password protected.
 - Data Storage and Web page access are protected using the same password.

For information on how to set and use firmware passwords, refer to the *Firmware Protection* topic in the *EcoStruxure™ Control Expert, Operating Modes* manual.

Program Unit, Section, and Subroutine Password

The program unit, section, and subroutine protection function — when enabled — uses a password to help protect these program elements. This function can be set and accessed from the Properties screen of the project in offline mode.

For information on how to set and use program unit, section, and sub-routing passwords, refer to the *Program Unit, Section, and Subroutine Protection* topic in the *EcoStruxure™ Control Expert, Operating Modes* manual.

Data Storage/Web Password

Protection by a password helps prevent unwanted access to the data storage zone of the SD memory card (if a valid card is inserted in the controller).

For M580 controllers in a project created by Control Expert with a version:

- Earlier than version 15.1, you can provide password protection for data storage access.
- Version 15.1 and later, you can provide password protection for both web diagnostics and data storage access.

For M580 controllers, management of the Data Storage and Web interfaces depends on the controller firmware version used to create the application:

- For controller firmware versions earlier than 4.01:
 - Data Storage is managed using FTP.
 - Data Storage access *can* be password protected.
 - Web page access cannot be password protected.
- For controller firmware versions 4.01 and later:
 - Data Storage is managed using HTTPS (more secure than FTP).
 - Both Data Storage and Web page access *must* be password protected.
 - Data Storage and Web page access are protected using the same password.

For information on how to set and use data storage/web passwords, refer to the *Data Storage/Web Protection* topic in the *EcoStruxure™ Control Expert, Operating Modes* manual.

Hardening the PC

Workstation PCs located in the control room are highly exposed to attacks. Those PCs supporting EcoStruxure™ Control Expert or EcoStruxure™ Server Expert need to be hardened.

As these applications all run on the Windows OS, this chapter offers guidelines on how to how to harden a PC by focusing on security for Windows 10.

Hardening the Engineering Workstation

The following key features are used to help secure the workstation. Click on an item for more information about that feature:

- Attack Surface Reduction, page 23
- Security Policy Configuration and Checking, page 23
- User Account Management, page 24
- Access Control Management, page 24

- Securing Network Services, page 25, including:
 - Disabling Remote Desktop Protocol, page 26
 - Disabling LANMAN and NTLM, page 26
 - Disabling Unused Network Interface Cards, page 27
 - Configuring the Local Area Connection, page 27
- Enable or Install Antivirus Protection Tool, page 27
- Systematic Patch Management, page 28
- Backup Management, page 28
- Confidentiality Management, page 29
- Audit Management, page 29

This topic also includes references to several Windows 10 cybersecurity configuration guides, page 29.

Attack Surface Reduction

The attack surface of your networked system is the collection of areas where an intruder can attempt to add or extract data.

To help reduce the potential attack surface:

- Disable all software applications, services, and communication ports that are not used.
- Disable or restrict access to removable storage devices (for example, USB).
- Use the workstation for only a single function (for example, install OPC UA Server Expert and Control Expert on different PCs).

Security Policy Configuration and Checking

Windows Security Policy can be set through Group Policy objects.

A Group Policy Object (GPO) is a set of configuration changes that can be applied to a PC workstation. For more information about Local Group Policy Editor, refer to the security configuration guides from the Center for Internet Security (CIS) referenced below., page 29

Domain GPOs can also be defined in Windows Active Directory.

Security configurations need to be checked regularly and automatically.

User Account Management

- **Change Default Passwords:**

Before deploying any new asset, change all default passwords to values that are consistent with administrative level accounts.

Disable Windows automatic login.

For a description of Windows account password settings, refer to the security configuration guides from the Center for Internet Security (CIS) referenced below., page 29

- **Setup User Accounts:**

The user accounts can be defined either locally (workgroup) on a standalone computer or through a Windows Active Directory domain controller that allow to centralize the management of all users in a system.

Follow these guidelines when setting up user accounts:

- Use a standard individual user account (without Administrator privilege) to run the software applications that are configured to run as standalone applications (for example, Control Expert).
- Use a local system account for the software applications that are configured to run as a Service (for example, OFS UA).
- Use a dedicated Administrative account to install the software applications and to configure IPsec.
- Set up a password manager to manage your passwords (for example, KeyPass).
- Disable all accounts that are not associated to business (for example, Debug accounts). Refer to CIS control 16.8., page 29
- Automatically disable dormant accounts after a set period of inactivity. Refer to CIS control 16.9., page 29
- Automatically lock workstation sessions after a standard period of inactivity. Refer to CIS control 16.11., page 29

Access Control Management

Access to all information stored on systems with file system, network share, claims, application, or database needs to be controlled. These controls enforce the **Least Privilege Principle**, i.e., that only authorized individuals can access information, and the information they can access is the information they minimally require given their responsibilities.

Permissions are related to objects. Depending on the objects, permission can be implemented based on:

- Windows Active Directory objects.

- NTFS Files access through discretionary access control list (DACLS).
- Shared folder permissions.
- Remote Registry service (enable/disable).

Privileges are user rights that are not tied to an object, but are instead machine-specific. They can be managed through Group Policy settings, for example, “Removable storage access” settings in Local group policy editor can restrict access to USB device storage (read or write).

Helping Secure Network Services

Uninstall or disable unnecessary or unused network services.

There are several ways to disable a service (Services Tool, Security Template, Group Policy Object, PowerShell, SC.exe).

Use Windows firewall with a default-deny rule that drops all traffic except those services and ports that are explicitly allowed.

- **Firewall usage:**

The Windows firewall is needed for IPSEC configuration on Windows 10. In recent versions of Windows operating systems, including Windows 10, the firewall is enabled by default. More details on Windows Firewall settings refer to the security configuration guides from the Center for Internet Security (CIS) referenced below.

- **Server Manager tool:**

Server Manager lets you view all the dependencies of a feature so you can determine if it is wise to remove it from a Windows Server.

Server roles can be selected (for example, Web Server (IIS), DNS Server, and so forth).

Server features can be selected (for example, BitLocker, .NET Framework, and so forth).

- **Internet Information Server (IIS) – Web Server Security:**

Use a minimal installation of the latest version.

Configure IIS Access Control (TLS and user authentication).

Enable logging and review the logs for hacking signatures.

More details on IIS settings are provided in the CIS benchmark document (Refer to the link, below., page 29)

- **Disabling SMBv1:**

Server Message Block version 1 (SMBv1) is a protocol used for sharing services (such as printing, files and communication) between PCs on a network. SMBv1 has been demonstrated to present the vulnerability of allowing remote code execution on the host PC.

You can disable SMBv1 to help minimize vulnerabilities.

Disabling the Remote Desktop Protocol

Schneider Electric's defense-in-depth approach guidelines include disabling remote desktop protocol (RDP) unless your application requires the RDP. The following steps describe how to disable the protocol:

Step	Action
1	In Windows 10, disable RDP via Computer > System Properties > Advanced System Settings .
2	On the Remote tab, deselect the Allow Remote Assistance Connections to this Computer check box.
3	Select the Don't Allow Connection to this Computer check box.

Disabling LANMAN and NTLM

Disable both the Microsoft LAN Manager protocol (LANMAN) and its successor NT LAN Manager (NTLM) to help minimize vulnerabilities.

The following steps describe how to disable LANMAN and NTLM in a Windows 10 system:

Step	Action
1	In a command window, execute <code>secpol.msc</code> to open the Local Security Policy window.
2	Open Security Settings > Local Policies > Security Options .
3	Select Send NTLMv2 response only. Refuse LM & NTLM in the Network Security: LAN Manger authentication level field.
4	Select the Network Security: Do not store LAN Manager hash value on next password change check box.
5	In a command window, enter <code>gpupdate</code> to commit the changed security policy.

Disabling Unused Network Interface Cards

Disable network interface cards not required by the application. For example, if your system has 2 cards and the application uses only one, verify that the other network card (Local Area Connection 2) is disabled.

To disable a network card in Windows 10:

Step	Action
1	Open Control Panel > Network and Internet > Network and Sharing Center > Change Adapter Settings .
2	Right-click the unused connection. Select Disable .

Configuring the Local Area Connection

Various Windows network settings provide enhanced security aligned with the defense-in-depth approach.

In Windows 10 systems, access these settings by opening **Control Panel > Network and Internet > Network and Sharing Center > Change Adapter Settings > Local Area Connection (x)**.

This list is an example of the configuration changes you might make to your system on the **Local Area Connection Properties** screen:

- Disable all IPv6 stacks on their respective network cards.
- Deselect all **Local Area Connection Properties** items except for **QoS Packet Scheduler** and **Internet Protocol Version 4**.
- Under the **Wins** tab on **Advanced TCP/IP Settings**, deselect the **Enable LMHOSTS** and **Disable NetBIOS over TCP/IP** check boxes.
- Enable **File and Print Sharing for Microsoft Network**.

Schneider Electric's defense-in-depth guidelines also include the following:

- Define only static IPv4 addresses, subnet masks, and gateways.
- Do not use DHCP or DNS in the control room.

Enable or Install Antivirus Protection Tools

You can improve the system response against viruses and malicious code using your built-in tools in Windows 10. You can also install additional antivirus software if necessary.

Enterprise editions of Windows 10 include *Windows Defender Advanced Threat Protection*, a security platform that monitors endpoints, such as Windows 10 PCs using behavioral sensors. Microsoft's *SmartScreen* technology is another built-in feature that scans, downloads and blocks the access to websites and downloads that are known to be malicious.

More details on *Windows Defender* settings are provided in the Center for Internet Security (CIS) document referenced below, including:

- Ensure that the organization's anti-malware software updates its scanning engine and signature database on a regular basis (CIS Control 8.2).
- Configure Anti-Malware Scanning of Removable Media: USB (Refer to CIS Control 8.4)., page 29
- Configure devices to not auto-run content from removable media: USB (Refer to CIS control 8.5)., page 29

Systematic Patch Management

Always install the last stable version of any security-related updates of the Operating System, Applications (including web browsers and e-mail client), Drivers.

Enable auto update in Windows 10.

More details are provided in the Center for Internet Security (CIS) document referenced below., page 29

Backup Management

Ensure that:

- All system data is automatically backed up on a regular basis (Refer to CIS control 10.1)., page 29
- The organization's key systems are backed up as a complete system, through processes such as imaging, to enable the quick recovery of an entire system. (Refer to CIS control 10.2)., page 29
- Backups are properly protected via physical security or encryption when they are stored, and also when they are moved across the network. This includes remote backups and cloud services. (Refer to CIS control 10.4)., page 29
- All backups have at least one offline (i.e., not accessible via a network connection) backup destination (Refer to CIS control 10.5)., page 29

You can:

- Use *File History* and other free tools in Windows 10 to create file backups.

- Create a recovery drive to restore your system from an image backup.
- Use a storage-sync-and-share service, to put your backups in the cloud. These are easy to set up, especially some of the most popular ones like *OneDrive*, *Dropbox*, or *Google Drive*.

More details on Windows File History, backup/restore settings are provided in CIS document referenced below.

Confidentiality Management

Remove sensitive data or systems not regularly accessed by the organization from the network. These systems can be used as stand-alone systems (disconnected from the network) of the business unit that needs to occasionally use them, or can be completely virtualized and powered off until needed. Refer to the CIS document referenced below. (Refer to CIS control 13.2)., page 29

Turn on disk encryption with *Bitlocker*. More details on *Bitlocker* settings are provided in the CIS Document referenced below.

Audit Management

Ensure that local security logging has been configured on Windows hosts. For details on Audit Policy configuration, refer to the CIS Document referenced below., page 29

Windows 10 Cybersecurity Configuration Guides

Have a complete set of Windows 10 Cybersecurity settings to use Windows configuration guides, including:

- Security configuration guides from Center for Internet Security – CIS
<https://www.cisecurity.org/press-release/cis-controls-microsoft-windows-10-cyber-hygiene-guide/>
 - IG1 Level:
<https://www.cisecurity.org/cis-benchmarks/>
https://www.cisecurity.org/benchmark/microsoft_windows_desktop/
https://www.cisecurity.org/benchmark/microsoft_iis/
- Security configuration guidelines developed by United States Department of Defense (DISA STIG)
https://www.stigviewer.com/stig/windows_10/2020-06-15/

Both the "CIS benchmarks" document and "STIG Windows 10 Security technical implementation guide" propose optional profiles. Your choice of a profile depends on the criticality of your applications running on Windows.

Disable Unused Embedded Communication Services

Embedded Communication Services

Embedded communication services are IP-based communication services used in server mode on an embedded product (for example HTTP or FTP).

Disable Unused Services

To help reduce the attack risks, disable any unused embedded service — for example HTTP and FTP — to close potential communication doors.

Disable Ethernet Services in Control Expert

You can enable/disable Ethernet services using the Ethernet tabs in control Expert. Tabs description is provided for each of the following systems:

- Modicon M340, page 120
- Modicon M580, page 121
- Modicon Quantum, page 121
- Modicon X80 modules, page 123
- Modicon Premium/Atrium, page 125

Set the Ethernet tabs parameters before you download the application to the controller.

The default settings (maximum security level) reduce the communication capacities. If services are needed, they have to be enabled.

NOTE: On some products, the `ETH_PORT_CTRL` (see EcoStruxure™ Control Expert, Communication, Block Library) function block allows to disable a service enabled after configuration in Control Expert application. The service can be enabled again using the same function block.

Restrict Data Flow from Control Network (Access Control)

Data Flow from Control Network

Data flow from control network is an IP-based data flow initiated on the control network.

Description

In order to control the access to communication servers in an embedded product, the access control management restricts the IP-based data flow from control network to an authorized source or subnet IP address.

Architecture Example

The purpose of the following figure is to show the role and impact of the access control settings. The access control manages the Ethernet data flow from devices communicating on the operation and control networks (located in the grayed out area).

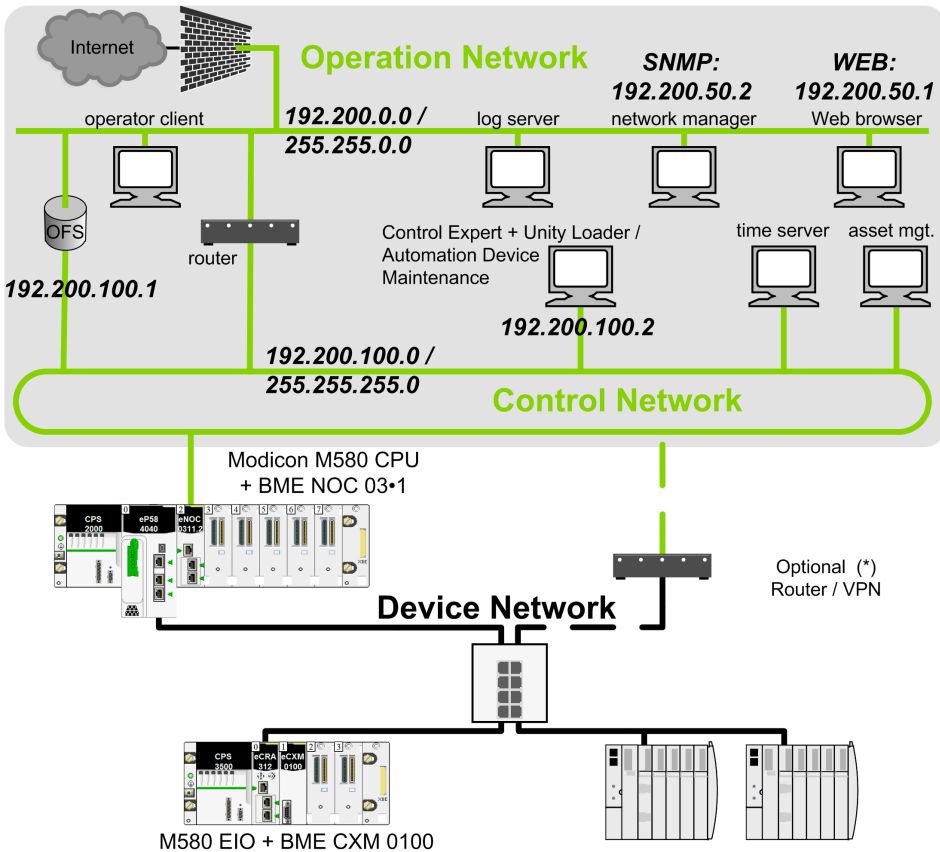

(*) Some services require access to the device network (for example: firmware update, at source time stamping). In such cases, an optional router/VPN helps secure the access control.

Setting the Authorized Addresses in the Architecture Example

Access control goals:

- Any equipment connected to the operation network (IP address = 192.200.x.x) can access the controller Web server.
- Any equipment connected to the control network (IP address = 192.200.100.x) can communicate with the controller with Modbus TCP and can access the Web server.

To restrict data flow in previous architecture example, the authorized addresses and services are set as follows in EcoStruxure Control Expert access control table:

Source	IP address	Subnet	Subnet mask	FTP	TFTP	HTTP / HTTPS	Port502	EIP	SNMP
Network manager	192.200.50.2	No	–	–	–	–	–	–	+
Operation network	192.200.0.0	Yes	255.255.0.0	–	–	+	–	–	–
Automation Device Maintenance	192.200.100.2	No	–	+ 1)	–	– 2)	+	–	–
Control network	192.200.100.0	Yes	255.255.255.0	–	–	–	+	–	–

+ Selected

– Not selected or no content

1) For M580 firmware versions equal to or greater than v4.10, FTP is not selected.

2) For M580 firmware versions equal to or greater than v4.10, HTTP/HTTPS is selected.

Settings Description

An authorized address is set for devices authorized to communicate with the controller using Modbus TCP or EtherNet/IP.

Services settings explanation for each IP address in previous example:

192.200.50.2 (SNMP)	Set to authorize the access from the network manager using SNMP.
192.200.0.0 (HTTP/HTTPS)	Operation network subnet is set to authorize all Web browsers connected to the operation network to access the controller web browser.
192.200.100.2 (FTP) 1)	Set to authorize the access from Automation Device Maintenance with FTP.
192.200.100.0 (Port502)	Control network subnet is set to authorize all equipment connected to the control network (OFS, Control Expert, Automation Device Maintenance) to access the controller via Port502 Modbus.

1) For M580 firmware versions equal to or greater than v4.10, FTP is not used. Instead, use HTTP/HTTPS.

NOTE: The access list analysis goes through each access control list entry. If a successful match (IP address + allowed service) is found, then the other entries are ignored.

In the EcoStruxure Control Expert **security** screen, for a dedicated subnet enter the specific rules before the subnet rule. For example: To give a specific SNMP right to device 192.200.50.2, enter the rule before the global subnet rule 192.200.0.0/255.255.0.0 which allows HTTP access to all the devices of the subnet.

Set Up Encrypted Communication

Introduction

The goal of encrypted communication is to help protect the communication channels that allow remote access to the critical resources of the system (such as Modicon M580 PAC embedded application, firmware). IPsec (Internet Protocol Security) is an open standard defined by the IETF to provide protected and private communications on IP networks provided by using a combination of cryptographic and protocol security mechanisms. Our IPsec protection implementation includes anti-replay, message integrity check, and message origin authentication.

IPsec is supported on Microsoft Windows versions 7 and 10. It is initiated from the PC operating system.

Description

The IPsec function helps to secure:

- The control room Modbus access to the controller through the BMENOC0301 and BMENOC0311 modules.
- The control room access to the communication services running inside the BMENOC0301 and BMENOC0311 modules in server mode (Modbus, EtherNet/IP, HTTP, FTP, SNMP).

NOTE: IPsec is intended to help secure services running in server mode in the controller. Secure client services initiated by the Modicon M580 PAC are outside the scope of this manual.

Wireless connection: When a PMXNOW0300 wireless module is used to configure a wireless connection, configure this module with the maximum security settings available (WPA2-PSK).

Architecture Example

The purpose of the following figure is to illustrate through an example the various protocols or services involved in a encrypted communication from the control room to a Modicon M580 controller.

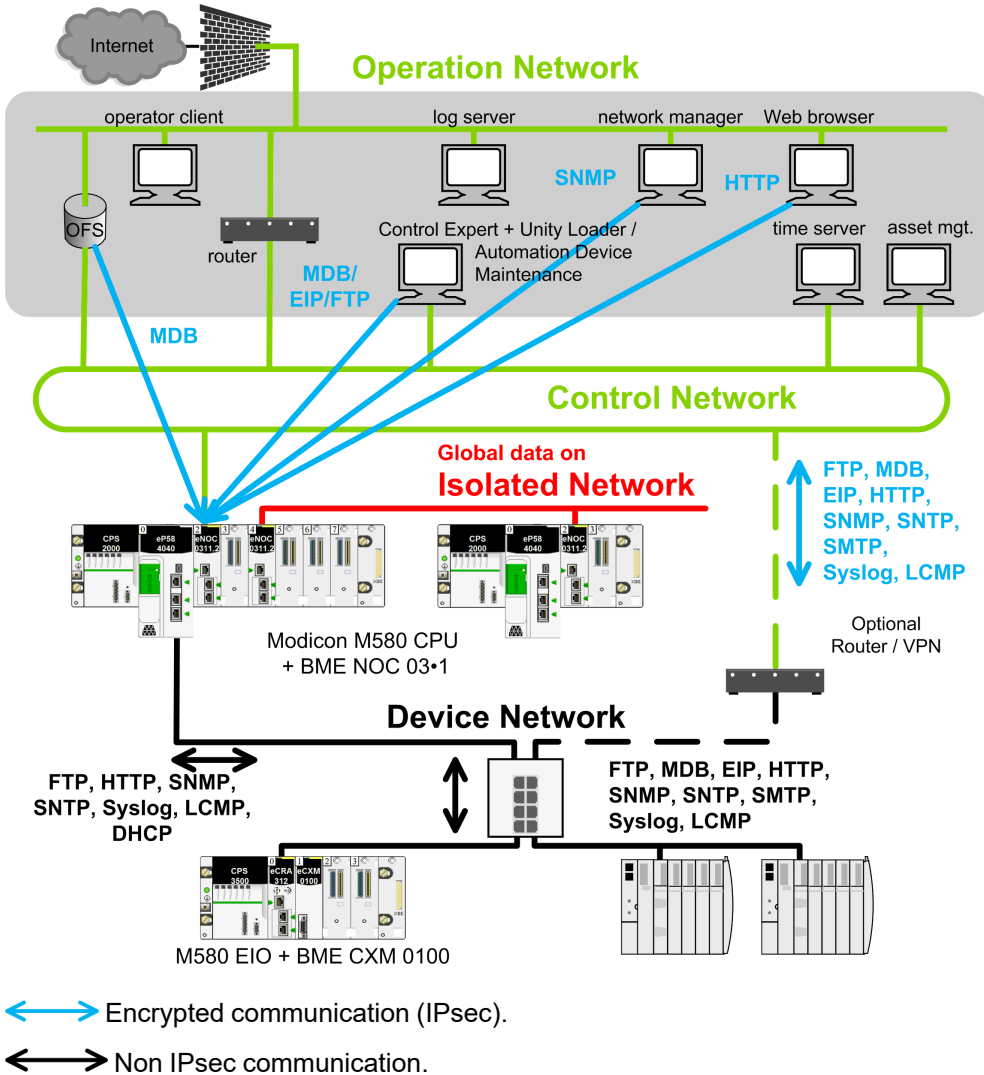

Data Flow with Encrypted Communication Capability

Use these services to facilitate communications when IPsec is enabled:

Ethernet Service	Data Flows Security
EIP class 3 server	These services are supported through encrypted connections.
FTP server, TFTP server	
HTTP	
ICMP (ping, etc.)	
Modbus server (port 502)	
ARP	These services are supported through encrypted and unencrypted connections. NOTE: This traffic bypasses the IPsec protocol handling in the BMENOC and therefore does not use IPsec.
LLDP	
loop check protocol	
Modbus scanner	
RSTP	
DHCP, BootP client	These services are not supported when IPsec is enabled. NOTE: Before IKE/IPsec is initiated by the peer (PC), this traffic is not secured by IPsec. After IKE/IPsec is established, this traffic is encrypted by IPsec. Protocol could be supported, but only if packet recipient is a PC with IPsec configured and enabled.
DHCP, BootP server	
EIP class 1, TCP (forward open)	
EIP class 1, UDP (data exchange)	
Modbus client	
NTP client	
SNMP agent	
SNMP traps	
Syslog client (UDP)	

NOTE:

- IPsec is an OSI layer 3 protection. OSI layer 2 protocols (ARP, RSTP, LLDP, loop check protocol) are not protected by IPsec.
- **Global Data** communication flow (using BMXNGD0100 modules) cannot be secured by IPsec. Use such a configuration on an isolated network.

Limitations

IPsec limitations in the architecture: BMENOC0301 and BMENOC0311 modules do not support IP forwarding to device network.

If transparency is required between control and device network, an external router/vpn is needed to provide an encrypted communication between the control and device network (as shown in previous architecture example figure, page 35).

Transparency is required to perform the following operations from the control network:

- Update an M580 controller firmware from the Automation Device Maintenance through HTTPS service.
- Perform a network diagnostic of M580 controller from a network management tool through SNMP service.
- Diagnose an M580 controller from a DTM through EIP service.
- Diagnose an M580 controller from a Web browser through HTTP service.
- Log an M580 controller cybersecurity events in a syslog server through syslog service.
- Synchronize an M580 controller time from a global time server through NTP service.

Setting Up IPsec Communication in the System Architecture

Proceed with the following steps to set up the IPsec communication:

- In the control room, identify the client authorized applications that need to communicate with the Modicon M580 PAC system using Modbus (Control Expert, Automation Device Maintenance, OFS, customer applications such as SGBBackup, ...).
Configure IPsec on each PC supporting these authorized applications.
- In the control room, identify the client authorized applications that need to communicate with the BMENOC0301 and BMENOC0311 modules configured in the local rack (Control Expert DTM, Automation Device Maintenance, SNMP manager, Web browser, Web designer for FactoryCast BMENOC0301 and BMENOC0311 modules).
Configure IPsec on each PC supporting these authorized applications.

- Incorporate BMENOC0301 and BMENOC0311 modules with IPsec function on the backplane of each Modicon M580 PAC system connected to the control network.

To configure the IPsec function on BMENOC0301 and BMENOC0311 modules, proceed in 2 steps:

- Enable IPsec function.
- Configure a pre-shared key. A pre-shared key is used to build a shared secret allowing two devices to authenticate each other.

NOTE: Because IPsec relies on this shared secret, it is a key element in the security policy that is managed by the security administrator. To help increase the security of the pre-shared key, use an external tool such as KeePass, page 38 to generate an appropriate character string.

Configuration of the BMENOC0301 and BMENOC0311 modules is performed with Control Expert. In order to help secure this configuration, the first download is best accomplished through a point to point connection, such as the USB port. Thereafter, future downloads may be performed through Ethernet with an IPsec function, assuming IPsec is enabled.

Each PC supporting IPsec needs to comply with the following requirements for IPsec configuration:

- Use Microsoft Windows 10 OS.
- Have the administrator rights to configure IPsec.

Once the IPsec configuration is performed, set the Windows account as a normal user account without administrator privilege.

- **Harden the PC as explained in the *Hardening the PC* topic, page 22.**

More details on configuration are provided in the *Configuring IP Secure Communications* topic (see Modicon M580 BMENOC0301/0311, Ethernet Communications Module, Installation and Configuration Guide).

Generate Pre-Shared Keys with the Highest Security

The security of IPsec communications relies on the complexity of the pre-shared key. Use specialized tools to generate pre-shared keys of the highest security.

One such tool is KeePass, which you can download as freeware from the Internet. Download and install KeePass to your PC and launch it.

Configure and use KeePass v2.34 to generate passwords that can be used as pre-shared keys:

Step	Action
1	Create a new key database folder (File > New),
2	In the Create New Password Database dialog box, enter a folder name in the File name field and record your modifications.
3	In the Create Composite Master Key dialog box, enter a Master password . Enter the password again in the Repeat password field.
4	Press OK to open Step 2 and press OK again.
5	In the new database dialog box, expand New Database .
6	Select Network and add an entry (Edit > Add Entry).
7	In the Title field, enter a name for your module (for example, eNOC).
8	In the User name field, enter a user name.
9	Click the Generate a password icon.
10	Select Open password generator .
11	Press OK to populate the Password and Repeat fields.
12	Open the Password Generation Options dialog box (Tools > Generate Password).
13	<p>Make these selections at Generate using character set:</p> <ul style="list-style-type: none"> • Upper-case (A, B, C, ...) • Lower-case (a, b, c, ...) • Digits (0, 1, 2, ...) • Minus (-) • Underline (_) • Special (!, \$, %, &, ...) • Brackets ([,], [, (,), <, >) <p>NOTE: These characters are not accepted for use in the pre-shared key:</p> <ul style="list-style-type: none"> • { • } • ; • #
14	Press OK .
15	Right-click on your device in the Database list and scroll to Copy Password .
16	Open the security configuration screen in Control Expert.
17	Paste the key in the IPsec configuration screen.

Diagnose IPsec Communication in the System Architecture

Information on IPsec diagnostic in the system architecture is provided in the *Configuring IP Encrypted Communications* topic (see Modicon M580 BMENOC0301/0311, Ethernet Communications Module, Installation and Configuration Guide).

CSPN Security Target

CSPN Introduction

CSPN (Certification de Sécurité de Premier Niveau) is a cybersecurity certification currently used in the country of France. A product with CSPN certification is expected to withstand a cyber attack driven by two-person months of skilled hackers. The M580 system is CSPN-certified. This topic describes the environment, programmable automation controller configurations, and parameters that meet CSPN requirements to effect the highest level of security.

Modicon M580 Introduction

The Modicon M580 PAC system is designed to control and command an industrial process continuously without human intervention. At each step, the controller processes the data received from its inputs, the sensors, and sends commands to its outputs, the actuators. Exchanges with the supervision (HMI, SCADA) are performed with BMENOC0301 and BMENOC0311 Ethernet communication modules on the local rack with the controller.

The following illustration describes a typical M580 system architecture that can be vulnerable to a security attack:

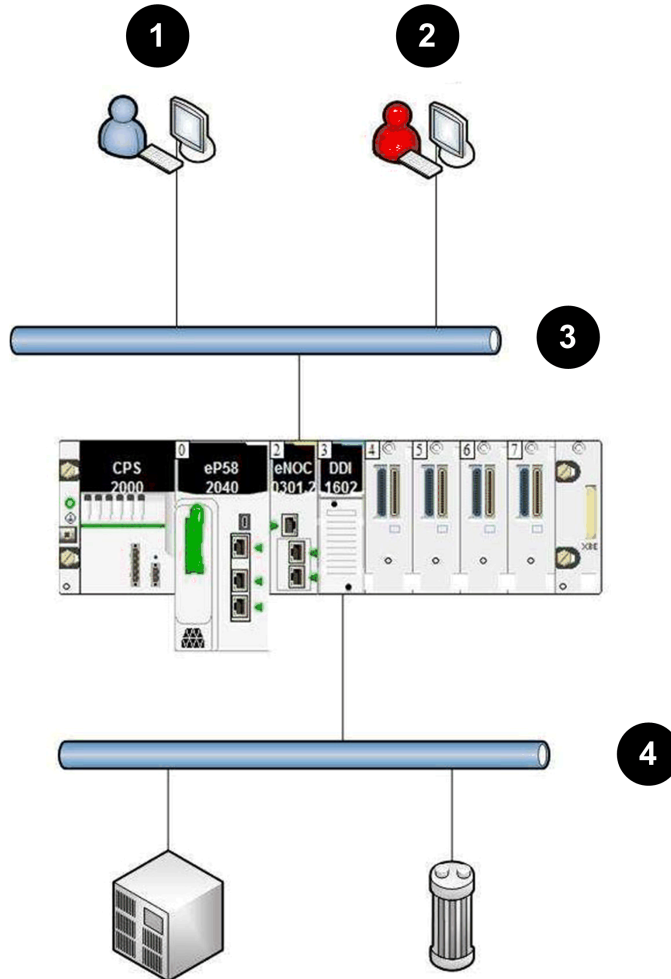

1 operator using EcoStruxure Control Expert

2 attacker

3 supervision network

4 field network with no attacker

M580 Features

The M580 controller offers the following features:

Feature	Description
user program execution	An M580 controller runs a user program that processes the inputs and updates the outputs.
input/output management	An M580 controller can read local inputs and write local outputs. These inputs/outputs can be digital or analog and allow the M580 controller to control and command the industrial process.
communication with the supervision	An M580 controller can communicate with SCADA to receive commands and transmit process data using the Modbus protocol.
administrative functions	An M580 controller includes administrative functions, which are provided in EcoStruxure Control Expert, for configuration and programming.
remote logging	An M580 controller supports the definition of a remote logging policy; it can log security and administrative events.

M580 Configuration

A CSPN-certified M580 configuration includes these components:

Module	Firmware	Description
BMEP58*0*0	as of version 2.20	The controller follows the security rules described in the security documents (see assumptions).
BMENOC0301 and BMENOC0311	as of version 2.11	This Ethernet module manages the encrypted communications with the upper layer (EcoStruxure Control Expert supervision and engineering software).

NOTE: EcoStruxure Control Expert programming software, PCs, other controller modules, and backplane components are not included in the scope of the certification.

User Profiles

Users that interact with the controller for an improved implementation have the following predefined EcoStruxure Control Expert Security Editor's profiles:

User Profile	Description
ReadOnly	No application modification is authorized.
Operate	Only application execution and parameter modification are enabled.
Program	All functions are enabled.

Improved Implementation

These items contribute to a healthy environment for an improved implementation:

Item	Security Considerations
security documentation	All instructions in the documentation (user guides, white papers, etc) are applied prior to the evaluation.
administrators	System administrators are competent, trained, and trustworthy.
premises	Access to the controller location is restricted to trustworthy people. In particular, an attacker does not have access to the physical ports of the controllers. Since identical products can be purchased freely, the attacker can obtain one to research vulnerabilities by any possible means.
unevaluated services disabled	Any services that are not covered by the security target are disabled in the configuration or by a user program (as described in the security documentation).
user application verification	The integrity of the EcoStruxure Control Expert application is controlled by the administrator before it is loaded in the controller.
active logging	The logging function is operational and the logs are not corrupt.
log checking	System administrators regularly check the local and remote logs.
first configuration	The initial configuration is uploaded to the controller through the USB interface, and the controller is unplugged from the network.
firmware upgrade	The firmware upgrade is performed through the USB interface, and the controller is unplugged from the network.
strong passwords	System administrators employ strong passwords that combine uppercase letters, lowercase letters, numbers, and special characters.

Operating Modes

The following operating modes are compliant with CSPN requirements:

- During commissioning phase, initial configuration of the controller can be done with **either** a Control Expert engineering station connected in point-to-point to the Ethernet port **or** to the local USB port of the controller.
- In normal operating conditions (running mode, SCADA connected on the Ethernet control network), confirm that Control Expert is disconnected.
- Perform any further modification of the configuration or application program with Control Expert connected to the USB port of the controller.

Cybersecurity Parameters

This table describes the cybersecurity parameters:

Parameter	Topic	User Guide
ACL activated.	Configuring Security Services	Modicon M580 BMENOC0301/0311, Ethernet Communications Module, Installation and Configuration Guide
IPsec activated on BMENOC0301/0311 with maximum security.	Configuring Security Services	
Enforce security selected (FTP, TFTP, HTTP, DHCP/BOOTP, SNMP, EIP, NTP protocols deactivated).	Configuring Security Services	
Log activated.	Logging DTM and Module Events to the Syslog Server	
RUN/STOP by input only activated.	Managing Run/Stop Input	M580 Hardware Reference Guide
Memory protection activated.	Memory Protect	
Helping secure a project: <ul style="list-style-type: none"> • Application locked with login and password. • Section protection activated. 	Helping Secure a Project in Control Expert	
No upload information stored inside controller.	Controller Embedded Data	EcoStruxure™ Control Expert, Operating Modes
Default password for FTP service changed.	Firmware Protection	
Application sections are set with no read/write access.	Section and Subroutine Protection	

Critical Assets

Environment: This table shows the assets that are critical to the environment:

Asset	Description for Proper Use
control-command of the industrial process	The controller controls and commands an industrial process by reading inputs and sending commands to actuators. The availability of these actions is protected.
engineering workstation flows	The flows between the controller and the engineering workstation are protected in integrity, confidentiality, and authenticity.

Security requirements for the environmental critical assets:

Asset	Availability	Confidentiality	Integrity	Authenticity
control-command of the industrial process	X			
engineering workstation flows		X	X	X

controller: This table shows the assets that are critical to the controllers:

Asset	Description for Proper Use
firmware	The firmware is protected both in integrity and authenticity.
controller memory	The controller memory contains the controller configuration and a program that is loaded by the user. Its integrity and authenticity are protected while it is running.
execution mode	The integrity and authenticity of the execution mode of the controller are protected.
user secrets	All passwords that are used to perform authentication are held in the confidence by the appropriate users.

Security requirements for the controller critical assets:

Asset	Availability	Confidentiality	Integrity	Authenticity
firmware			X	X
controller memory			X	X
execution mode			X	X
user secrets		X	X	

Security Threats

Threats considered by attackers controlling a device plugged into the supervision network:

	Control-Command of the Industrial Process	Engineering Workstation Flows	Firmware	Controller Memory	Execution Mode	User Secrets
denial of service	Av					
firmware alteration		I, Au				
execution mode alteration					Au, I	
memory program alteration				I, Au		
flows alteration	Av	Au, C, I				C, I
Av: availability I: integrity C: confidentiality Au: authenticity						

Type of Threat	Description
denial of service	The attacker manages to generate a denial of service on the controller by performing an unexpected action or by exploring a vulnerability (sending a malformed request, using a corrupted configuration file...). This denial of service affect the entire controller or some of its functions.
firmware alteration	The attacker manages to inject and run a corrupted firmware on the controller. The code injection may be temporary or permanent, and does not include any unexpected or unauthorized code execution. A user may attempt to install that update on the controller by legitimate means. Finally, the attacker manages to modify the version of the firmware installed on the controller without having the privilege to do so.
execution mode alteration	The attacker manages to modify the execution mode of the controller without being authorized (a stop command for instance).
memory alteration	The attacker manages to modify, temporarily or permanently, the user program or configuration that run in the controller memory.
flows alteration	The attacker manages to corrupt exchanges between the controller and an external component without being detected. He can perform attacks such as credential theft, access control violation, or control-command of the industrial process mitigation.

	Persistent Denial of Service	Firmware Alteration	Execution Mode Alteration	Memory Alteration	Flows Alteration
malformed input management	X				
storage of secrets				X	

	Persistent Denial of Service	Firmware Alteration	Execution Mode Alteration	Memory Alteration	Flows Alteration
authentication on administrative interface					X
access control policy					X
firmware signature		X			
integrity and authenticity of controller memory				X	
integrity of the controller execution mode			X		
more secure communication					X

Type of Threat	Description
malformed input management	The controller has been developed to correctly handle malformed input, particularly malformed network traffic.
strength of secrets	The controller has been developed to correctly handle malformed input, particularly malformed network traffic. <ul style="list-style-type: none"> the PSK used to mount the IPsec tunnel the application password used to read the .STU Control Expert file and connect the file to the controller other services passwords (like FTP)
authentication on administrative interface	Session tokens are protected against hijack and replay; they have a short lifespan. The identity and permissions of the user account are systematically checked before any privileged action. An application password is set in each configuration, which helps prevent any modification of the controller from a non-authentic user.
access control policy	The access control policy helps control the authenticity of privileged operations, i.e., operations that can alter identified critical assets. The access control list (ACL) is activated in each configuration, and only identified IP addresses can connect to the controller.
firmware signature	At each firmware update, integrity and authenticity of the new firmware are checked before updating.

Type of Threat	Description
integrity and authenticity of controller memory	<p>The memory protection feature is activated in each configuration, which helps prevent the modification of the running program without an action in specific inputs or outputs. If no input/output module is installed, the programming interface is blocked. The controller helps ensure the integrity and authenticity of the user program, so that authorized users can modify the program.</p> <p>The memory protection also helps ensure the configuration protection, which includes several security parameters:</p> <ul style="list-style-type: none"> • Access control policy. • RUN/STOP by input only activated. • Memory protection activated. • Enabled/disabled services (FTP, TFTP, HTTP, DHCP, SNMP, EIP, NTP). • IPsec parameters. • Syslog parameters.
integrity of the controller execution mode	<p>The controller helps ensure that the execution mode can be modified by authorized users that are authenticated. The RUN/STOP by input only feature is activated, which helps prevent the possibility of changing the RUN/STOP status through the Ethernet interface.</p>
encrypted communication	<p>The controller supports encrypted communication, protected in integrity, confidentiality, and authenticity (IPsec encrypted with ESP).The FTP protocol is disabled, and IPsec helps secure Modbus communication through the BMENOC0301 and BMENOC0311 modules.</p>

Set Up Cybersecurity Audit (Event Logging)

Logging events and logging analysis are essential. The analysis traces user actions for maintenance and abnormal events that can indicate a potential attack.

The complete system needs to have a robust logging system distributed in all devices. The events related to cybersecurity are logged locally and sent to a remote server using Syslog protocol.

In the system architecture, event logging involves two parties:

- A log server that receives all the cybersecurity events of the system through Syslog protocol.
- Log clients (Ethernet connection points where cybersecurity events are monitored: device, Control Expert).

Event Log Service Description

Each log client role is to:

- Detect and time-stamp events.

A single NTP reference needs to be configured in the system to time-stamp the cybersecurity events.

- Send the detected events to the event logging server.

The events are exchanged between the client and the server using Syslog protocol (RFC 5424 specification).

The Syslog messages respect the format described in RFC 5424 specification.

Syslog exchanges are done with TCP protocol.

On devices, events are not lost in case of transient network breakdown. Events are lost in case of device reset (except for Modicon M580 controller firmware ≥ 4.0).

Facility Values for Event Types

Syslog message facility values as per RFC 5424 specification associated with event types:

Facility value	Description
0	Kernel messages.
1	User-level messages.
2	Mail system.
3	System daemons.
4	Security / authorization messages.
5	Messages generated internally by Syslog.
6	Line printer subsystem.
7	Network news subsystems.
8	UUCP subsystem
9	Clock daemon.
10	Security / authorization messages.
11	FTP daemon.
12	NTP subsystem.
13	Log audit.
14	Log alert.
15	Clock daemon.
16...23	Local use 0...7.

Severity Values for Event Types

Syslog message severity values as per RFC 5424 specification associated with event types:

Severity Value	Keyword	Description
0	Emergency	System is unusable.
1	Alert	Action must be taken immediately.
2	Critical	Critical conditions.
3	Error	Error conditions.
4	Warning	Warning conditions.
5	Notice	Normal but significant condition.
6	Informational	Informal messages.
7	Debug	Debug-level messages.

Architecture Example

The following figure highlights the position of logging server in a system architecture:

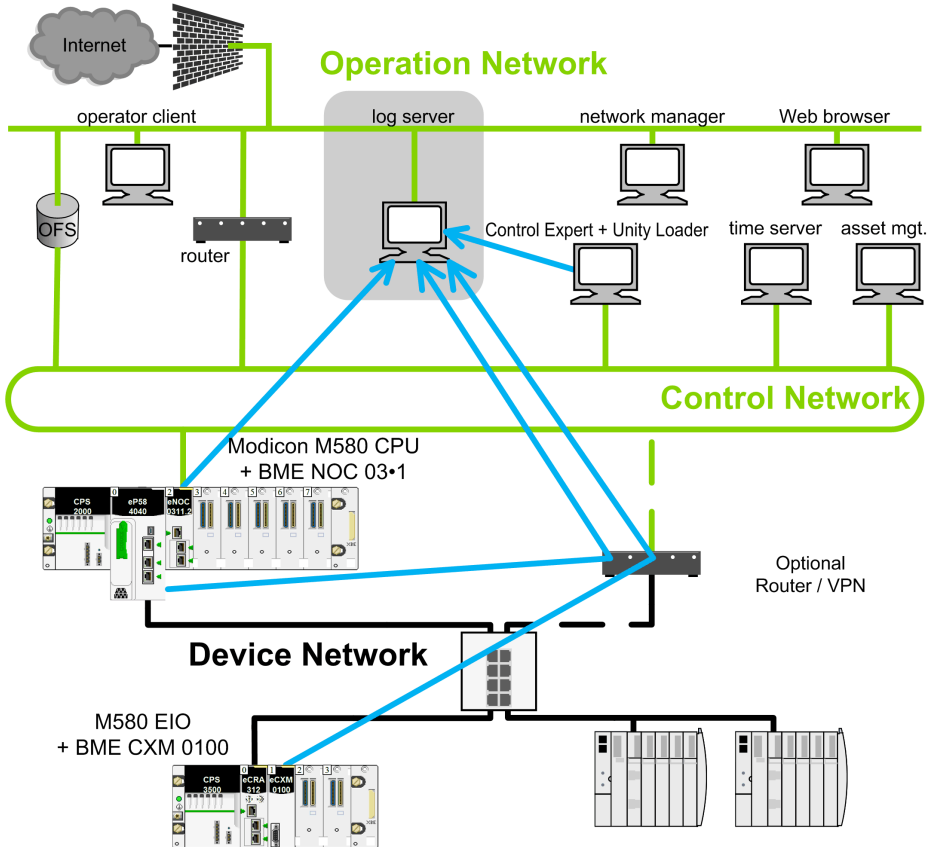

↔ Syslog messages.

Logged Event Message Structure for Modicon M580 Controller (as of Firmware Version 4.10) and BMENOR2200H (as of Firmware Version 3.01)

Fields	Description
PRI	Facility and severity information: "FACILITY" = 10 for cybersecurity events
VERSION	Version of the Syslog protocol specification (Version = 1 for RFC 5424).

Fields	Description
TIMESTAMP	<p>Time stamp format is issued from RFC 3339 that recommends the following ISO8601 Internet date and time format: YYY-MM-DDThh:mm:ss.nnnZ</p> <p>NOTE: -, T, :, ., , Z are mandatory characters and they are part of the time stamp field. T and Z need to be written in uppercase. Z specifies that the time is UTC.</p> <p>Time field content description:</p> <ul style="list-style-type: none"> • YYY: Year • MM: Month • DD: Day • hh: Hour • mm: Minute • ss: Second • nnn: Fraction of second in millisecond (0 if not available)
HOSTNAME	<p>Identifies the machine that originally sent the Syslog message: fully qualified domain name (FQDN) or source static IP address if FQDN is not supported.</p> <p>Source @IP address = @IP address A OR @IP address B in case of HSBY controller</p>
APP-NAME	Identifies the application that initiates the Syslog message. It contains information that identifies the entity sending the message (for example, subset of commercial reference).
PROCID	Process or protocol name that originated the message (for example, Modbus, HTTPS, LocalHMI)
MSGID	An identifier of the type of the event. (for example, CONNECTION_FAILURE_AND_BLOCK).
Event information	<pre><ac:structured-macro ac:name="unmigrated-wiki-markup" ac:schema-version="1" ac:macro-id="30296255-e8b7-4cf1-982e-2c45b17b1f06"><ac:plain-text-body><![CDATA[[authn@3833], [authz@3833], [config@3833], [cred@3833], [backup@3833], [plc@3833] [system@3833]]]></pre> <p>See STRUCTURED-DATA description below.</p>
MSG	Message containing the event-specific result (see Event Log Message Descriptions for Control Expert, page 56)

- **STRUCTURED-DATA** Description: mandatory event information.
 - **[meta]**: mandatory structured-data to provide meta-information about the message. Where parameter is:
 - **sequenceId**: the event identifier (rollover to 1 when maximum value 2147483647 is reached).
 - **sysUpTime**: this value should be included when component is incapable of obtaining system time (integer containing the time in 1/100th of the second since the system was last re-initialized).

- **STRUCTURED-DATA** Description: event information depending on event category.
 - **[authn@3833]**: structured-data used for authentication events. Where parameters are:
 - **itf**: the interface where the user is connected to, either a network port or a local interface (hmi, usb , ...).
 - **peer**: the FQDN or IP address of the component from which the user is connected, plus its port (ipAddress:port), optional in case of local interface
 - **user**: the user name (component or human), optional if user name unknown.
 - **[authz@3833]**: structured-data used for authorization events. Where parameters are:
 - **user**: the user name (component or human)
 - **object**: the object access by the user, object is product dependant.
 - **action**: the action performed on the object: Create, Read, Update, Delete (CRUD)
 - **[config@3833]**: structured-data used for configuration events. Where parameters are:
 - **object**: the name of the security object to configure (Firmware, RBAC, Security Policy, Device Setting, Trust Anchor, product dependant objects)
 - **value**: optional version or value of the new object
 - **[cred@3833]**: structured-data used for credential management events. Where parameters are:
 - **name**: the common name of the certificate or the user login name
 - **[system@3833]** structured-data for system events. Where parameters are:
 - **object**: the name of the system object that change (controller, module, Rotary Switch, SD Card, product dependant object)
 - **[backup@3833]**: structured data used for backup. Where parameters are:
 - **object**: the part of the component that has been backup/restore, object is product dependant.
 - Structured data can also be defined by each application for specific events.

Logged Event Message Structure for Modicon M580 Controller (Firmware earlier than Version 4.10), BMENUA0100 (Firmware Versions 1.10 & 2.0), and BMENOR2200H (Firmware earlier than Version 3.01)

Syslog message structure for Modicon M580 controller firmware and BMENUA0100:

Field	Description
PRI	Facility and severity information (description provided in following tables).
VERSION	Version of the Syslog protocol specification (Version = 1 for RFC 5424.).
TIMESTAMP	<p>Time stamp format is issued from RFC 3339 that recommends the following ISO8601 Internet date and time format: YYYY-MM-DDThh:mm:ss.nnnZ</p> <p>NOTE: -, T, :, ., Z are mandatory characters and they are part of the time stamp field. T and Z need to be written in uppercase. Z specifies that the time is UTC.</p> <p>Time field content description:</p> <ul style="list-style-type: none"> • YYYY: Year • MM: Month • DD: Day • hh: Hour • mm: Minute • ss: Second • nnn: Fraction of second in millisecond (0 if not available)
HOSTNAME	Identifies the machine that originally sent the Syslog message. Fully Qualified Domain Name (FQDN) or source static IP address if FQDN is not supported.
APP-NAME	Identifies the application that initiates the Syslog message. It contains information that identifies the entity sending the message (for example, subset of commercial reference).
PROCID	<p>Process or protocol name that originated the message (for example, Modbus, HTTPS, LocalHMI,)</p> <p>Receives NILVALUE if not used.</p>
MSGID	<p>Identifies the type of message on which the event is related to, for example HTTP, FTP, Modbus.</p> <p>Receives NILVALUE if not used.</p>
MESSAGE TEXT	<p>This field contains:</p> <ul style="list-style-type: none"> • Issuer address: IP address of the entity that generates the log. • Peer ID: Peer ID if a peer is involved in the operation (for example, user name for a logging operation). Receives null if not used. • Peer address: Peer IP address if a peer is involved in the operation. Not used (null). • Type: Unique number to identify a message (see Event Log Message Descriptions for Control Expert, page 56). • Comment: String that describes the message (see Event Log Message Descriptions M580 Controllers (as of Firmware Version V4.10), and BMENOR2200H (as of Firmware Version 3.01), page 62).

Setting Up a Syslog Server in the System Architecture

Several Syslog servers are available for various operating systems.

NOTE: Syslog servers must be compliant with RFC 5424.

Examples of Syslog server providers:

- WinSyslog: For Windows operating system.
Link: www.winsyslog.com/en/.
- Kiwi Syslog: For Windows operating system.
Link: www.kiwisyslog.com/products/kiwi-syslog-server/product-overview.aspx.
- Splunk: For Windows and Unix operating systems.
Link: www.splunk.com/.
- Rsyslog: For Unix operating system.
Link: www.rsyslog.com/.
- Syslog-ng: Open source for Unix operating system.
Link: www.balabit.com/network-security/syslog-ng/opensource-logging-system.
- Syslog Server: Open source for Windows operating system.
Link: sourceforge.net/projects/syslog-server/.

Setting Up Syslog Clients in the System Architecture

Event logging is managed in Control Expert for all devices and Device Type Managers (DTMs).

The event logging function, server address, and port number are configured in Control Expert as follows, and these parameters are sent to each client in the system after the **Build** action:

Step	Action
1	Click Tools > Project Settings .
2	Click Project Settings > General > PLC diagnostics .
3	Select Event Logging check box (cleared by default). NOTE: A project with this setting selected can only be opened as of Unity Pro 10.0. Unity Pro is the former name of Control Expert for version 13.1 or earlier.
4	Enter a valid SYSLOG server address and SYSLOG server port number .
5	Perform a Build after configuring this setting (you are not required to select Analyze Project).

Diagnose Event Logging

The following table displays the type of event logging diagnostics available for various devices:

Devices	Diagnostic information
Control Expert	If a communication error with the Syslog server occurs, the detected error is recorded in the event viewer. To enable the event viewer in Control Expert, select the Audit check box in the Policies tab of the Security Editor (see EcoStruxure™ Control Expert, Security Editor, Operation Guide).
BMENOC0301 and BMENOC0311 device DDT (<i>SERVICE_STATUS2</i> parameter)	Two diagnostic information is available: <ul style="list-style-type: none"> EVENT_LOG_STATUS: Value = 1 if event log service is operational. Value = 0 if event log service is not operational. LOG_SERVER_NOT_REACHABLE: Value = 1 if the Syslog client does not receive acknowledgment of the TCP messages from the Syslog server. Value = 0 if the acknowledgment is received.
Modicon M580 controller device DDT	
BMECXM Device DDT	

Event Log Message Descriptions for Control Expert

Logged Event	Description	Facility	Severity	MSG ¹⁾
Application action	Creation of a new Control Expert Application	10	6	create a new project
	Opening of an existing Control Expert Application	10	6	open an existing project
	Saving of the currently opened application	10	6	save a project
	Saving of the currently opened application using a different file	10	6	save as a project
	Importing of an application	10	6	import a project
	Application build in offline mode	10	6	build offline
	Application build in on-line mode controller in Stop	10	6	build on-line stop
	Application build in Offline mode controller in RUN	10	6	build on-line run
	Start / stop / initialize the controller	10	6	start stop or initialize the PAC

Logged Event	Description	Facility	Severity	MSG ¹⁾
	Update initial values with present values	10	6	Update init values with present values
	Upload of the application from the controller	10	6	transfer project from PAC
	Download of the application to the controller	10	6	transfer project to PAC
	Transfer data values from file to controller	10	6	transfer data values from file to PAC
	Restore project backup in controller	10	6	restore project backup in PAC
	Save to project backup in controller	10	6	save to project backup in PAC
	Change controller address connection	10	6	Set address
	Control Expert options modifications	10	6	Modify options
	Variable value modification inside the controller	10	6	Modify variable values
	Variable forcing value modification inside the controller: internal bits	10	6	Force internal bits
	Variable forcing value modification inside the controller: outputs	10	6	Force outputs
	Variable forcing value modification inside the controller: inputs	10	6	Force inputs
	Task management	10	6	Task management
	Task cycle time modification	10	6	Task cycle time modification
	Suppress message in diag viewer	10	6	Suppress message in diag viewer
	Debug executable	10	6	Debug executable
	Replace project variable	10	6	Replace project variable
	Create libraries or families inside the library	10	6	Create libraries or families
	Delete libraries or families inside the library	10	6	Delete libraries or families
	Copy element (DFB/DDT) from the application into the library	10	6	Put object into library

Logged Event	Description	Facility	Severity	MSG ¹⁾
	Delete element (DFB/DDT) into the library	10	6	Delete object from library
	Copy element (DFB/DDT/EF/EFB) from the library into the application	10	6	Get object from library
	Modify documentation (application printing)	10	6	Modify documentation
	Modify functional view	10	6	Modify functional view
	Modify animation tables	10	6	Modify animation tables
	Modify constant values	10	6	Modify constant values
	Modify program structure	10	6	Modify program structure
	Modify program sections	10	6	Modify program sections
	Modify Project settings	10	6	Modify Project settings
	Variable created / removed into Data editor	10	6	Variable Add Remove
	Variable attribute modified	10	6	Variable Main Attributes modification
	Variable attribute modified	10	6	Variable Minor Attributes modification
	DDT Created / Removed into Data Editor	10	6	DDT Add Remove
	DDT Modified into Data Editor	10	6	DDT modification
	DFB Created / Removed into Data Editor	10	6	DFB type Add Remove
	DFB structure modified into Data Editor	10	6	DFB type structure modification
	DFB sections modified	10	6	DFB type sections modification
	DFB instance Modification into data editor	10	6	DFB instance Modification
	DFB instance Minor Attributes modification into Data Editor	10	6	DFB instance Minor Attributes modification
	Controller Configuration modification	10	6	Modify configuration
	Controller I/O Sniffing	10	6	IO sniffing
	Controller I/O Configuration modification	10	6	Modify the IO configuration
	Controller I/O Configuration adjust	10	6	Adjust the IO

Logged Event	Description	Facility	Severity	MSG ¹⁾
	Controller I/O Configuration Save Param from I/O Screen	10	6	Save param
	Controller I/O Configuration Save Param from I/O Screen	10	6	Restore param
	Operator Screens modification	10	6	Modify screens
	Modify messages	10	6	Modify messages
	Operator Screens : Family / Screen added / removed	10	6	Add/Remove screens or families
	Move FFB block	13	6	Move component
	Move Contact/Coil	13	6	Move component
	Insert FFB Block	13	6	Insert component
	Insert Contact/Coil	13	6	Insert component
	Delete FFB Block	13	6	Delete component
	Delete Contact/Coil	13	6	Delete component
	Set Effective parameter on FFB Block	13	6	Add variable
	Set Effective parameter on Contact/Coil	13	6	Add variable
	Remove Effective parameter on FFB Block	13	6	Delete variable
	Remove Effective parameter on Contact/Coil	13	6	Delete variable
	Change Effective parameter on FFB Block	13	6	Modify variable
	Change Effective parameter on Contact/Coil	13	6	Modify variable
	Make a link between two pins	13	6	Link pin
	Change size of extensible FFB block	13	6	Scale component
	Change size of vertical/horizontal link	13	6	Scale component
	Rename effective parameter	13	6	Rename variable
	Delete one single row	13	6	Delete row
	Delete multiple rows	13	6	Delete rows from
	Delete one single column	13	6	Delete column
	Delete multiple columns	13	6	Delete columns from

Logged Event	Description	Facility	Severity	MSG ¹⁾
	Insert one single row	13	6	Insert row
	Insert multiple rows	13	6	Insert rows from
	Insert one single column	13	6	Insert column
	Insert multiple columns	13	6	Insert columns from
DTM action	DTM Download parameter finished in error	9	6	Download parameters to device service finished in error
	DTM Download parameter finished without error	9	6	Download parameters to device service finished without error
	DTM Upload parameter finished in error	9	6	Upload parameters from device service finished in error
	DTM Upload parameter finished without error	9	6	Upload parameters from device service finished without error
	Connection to the DTM is not established	9	6	Go on-line service failed
	Connection to the DTM succeeded	9	6	Go on-line service succeeded
	Connection to the DTM is not closed	9	6	Go offline service failed
	Connection to the DTM closed successfully	9	6	Go offline service succeeded
	DTM FDR download parameters service is not performed	9	6	FDR download parameters service failed
	DTM FDR download parameters service succeeded	9	6	FDR download parameters service succeeded
	DTM FDR upload parameters service is not performed	9	6	FDR upload parameters service failed
	DTM FDR upload parameters service succeeded	9	6	FDR upload parameters service succeeded
	Download parameters to device service is not performed	9	6	Download parameters to device service failed
	Download parameters to device service succeeded	9	6	Download parameters to device service succeeded
	Upload parameters from device service is not performed	9	6	Upload parameters from device service failed
	Upload parameters from device service succeeded	9	6	Upload parameters from device service succeeded
Audit Trail Function Event	9	6	Audit Trail Function Event	
Audit Trail Device Status Event	9	6	Audit Trail Device Status Event	

Logged Event	Description	Facility	Severity	MSG ¹⁾
	No device status message	9	6	No device status message
	Status information	9	6	Status information
	Access right : Read / Write	9	6	Access right : Read / Write
	Enumerator entry	9	6	Enumerator entry
Password action	Problem at application password changing	2	6	CyberSecurity - Modifying Password > Incorrect Password
	Problem at application password verification	2	6	CyberSecurity - Verifying Password > Incorrect Password
	Problem at section password verification	2	6	CyberSecurity - Verifying Section Password > Incorrect Password
	Password "DataStorage" changed	2	6	CyberSecurity - Data Storage Password Modified
	Password "FW Download" changed	2	6	CyberSecurity - Firmware Password Modified
	Problem at application password verification	2	6	CyberSecurity - Verifying Password > Incorrect Password
SYSLOG configuration changed	CyberSecurity - Event Logging project setting has changed - Event Logging, SYSLOG server address, port or protocol	-	-	SYSLOG address changed
File action	File XXXXX open	0	6	XXXXX file has been opened
	Controller disconnected = @XXXXXX driver = YYYYYY	0	6	Disconnection from PAC @=XXXXXX dirver= YYYYYY
	Application XXXXXX close	0	6	Close application XXXXXX
	Transfer from controller to PC	0	6	project has been transfered from PAC to PC

¹⁾ MSG content includes the concatenation of the Username, the PID of Control Expert, plus the message.

NOTE: The fields HOSTNAME, APP-NAME, PROCID, MSGID, and STRUCTURED-DATA do not apply to Control Expert messages.

Event Log Message Descriptions M580 Controllers (as of Firmware Version V4.10), and BMENOR2200H (as of Firmware Version 3.01)

This topic presents event log message descriptions for:

- M580 controllers as of firmware version 4.10 (abbreviated **CPU** in column **Devices**)
- BMENOR2200H RTU modules as of firmware version 3.01 (abbreviated “eNOR” in the **Devices** column)

Logged Event	Description	Additional Description	Severity	PROCID	MSGID	STRUCTURED-DATA	MSG	Devices
Successful connection	All successful connection from a user (human or a component) to a component whether through an encrypted protocol or through an unencrypted protocol if allowed by the customer security policy	Successful login (Web Server through HTTPS)	6	HTTPS	CONNECTION_SUCCESS	[meta sequenceld=num] [authn@3833 itf=localPort localInterfa- cepeer= peerFQDN: peerPort user= username]	Logon	CPU, eNOR
		Successful login (Firmware upgrade through HTTPS)	6	HTTPS	CONNECTION_SUCCESS	[meta sequenceld=num] [authn@3833 itf=localPort localInterfa- cepeer= peerFQDN: peerPort user= username]	Logon	CPU, eNOR
		Successful login (OPC-UA)	6	OPC-UA	CONNECTION_SUCCESS	[meta sequenceld=num] [authn@3833 itf=localPort localInterfa- cepeer= peerFQDN: peerPort	Socket connection	CPU

Logged Event	Description	Additional Description	Severity	PROCID	MSGID	STRUCTURED-DATA	MSG	Devices
						user= username]		
		Successful login (Unity Application password through Modbus-Umas) Mode standard only	6	MODBUS-UMAS	CONNECTION_SUCCESS	[meta sequen- celd=num] [auth- n@3833 itf=localPort localInterfa- cepeer= peerFQDN: peerPort user= username]	Logon	CPU
		Successful Modbus TCP connection (no user)	6	MODBUS	CONNECTION_SUCCESS	[meta sequen- celd=num] [auth- n@3833 itf=localPort localInterfa- cepeer= peerFQDN: peerPort user= username]	Socket connection	CPU, eNOR
		Successful HTTP/DPWS connection	6	HTTP	CONNECTION_SUCCESS	[meta sequen- celd=num] [auth- n@3833 itf=localPort localInterfa- cepeer= peerFQDN: peerPort user= username]	Socket connection	CPU
		Successful EIP Explicit TCP connection (no user)	6	EIP	CONNECTION_SUCCESS	[meta sequen- celd=num] [auth- n@3833 itf=localPort localInterfa- cepeer= peerFQDN: peerPort	Socket connection	CPU

Logged Event	Description	Additional Description	Severity	PROCID	MSGID	STRUCTURED-DATA	MSG	Devices
						user= username]		
		Successful DNP3 connection (no user)	6	DNP3	CONNECTION_SUCCESS	[meta sequencel=num] [auth-n@3833 itf=localPort localInterface peer= peerFQDN: peerPort user= username]	Socket connection	eNOR
		Successful IEC 60870 connection (no user)	6	IEC60870	CONNECTION_SUCCESS	[meta sequencel=num] [auth-n@3833 itf=localPort localInterface peer= peerFQDN: peerPort user= username]	Socket connection	eNOR
Connection Problem	All unsuccessful connections from a user (human or a component) to a component whether through an encrypted protocol or through an unencrypted protocol if allowed by the customer	Login problem (Unity Application password through Modbus-Umas)	5	MODBUS-UMAS	CONNECTION_FAILURE	[meta sequencel=num] [auth-n@3833 itf=localPort localInterface peer= peerFQDN: peerPort user= username]	Invalid password	CPU
		Modbus TCP connection problem (no user)	5	MODBUS	CONNECTION_FAILURE	[meta sequencel=num] [auth-n@3833 itf=localPort localInterface peer= peerFQDN: peerPort	Max connections reached" "Filtered data flow	CPU, eNOR

Logged Event	Description	Additional Description	Severity	PROCID	MSGID	STRUCTURED-DATA	MSG	Devices
	security policy					user= username]		
		EIP Explicit TCP connection problem (no user)	5	EIP	CONNECTION_FAILURE	[meta sequen- celd=num] [auth- n@3833 itf=localPort localInterfa- cepeer= peerFQDN: peerPort user= username]	Max connections reached, Filtered data flow	CPU
		DNP3 connection problem (no user)	5	DNP3	CONNECTION_FAILURE	[meta sequen- celd=num] [auth- n@3833 itf=localPort localInter- face peer= peerFQDN: peerPort user= username]	Max connections reached"	eNOR
		IEC60870 connection problem (no user)	5	IEC60870	CONNECTION_FAILURE	[meta sequen- celd=num] [auth- n@3833 itf=localPort localInter- face peer= peerFQDN: peerPort user= username]	Max connections reached	eNOR
Human user account locking due to too many problems during the authentication attempts	The security policy may request to block a human user account after a configura- ble	Login problem (Web Server through HTTPS). Human user account locking due to too many	1	HTTPS	CONNECTION_FAILURE_AND_BLOCK	[meta sequen- celd=num] [auth- n@3833 itf=localPort localInterfa- cepeer= peerFQDN: peerPort	Invalid certificate, Invalid password	CPU, eNOR

Logged Event	Description	Additional Description	Severity	PROCID	MSGID	STRUCTURED-DATA	MSG	Devices
	number of attempts. This event informs administrator about potential attack & that the human user account must be unlocked.	problems during the authentication attempts				user= username]		
		Login problem (firmware upgrade through HTTPS). Human user account locking due to too many unsuccessful authentication attempts	1	HTTPS	CONNECTION_FAILURE_AND_BLOCK	[meta sequen- celd=num] [auth- n@3833 itf=localPort localInterfa- cepeer= peerFQDN: peerPort user= username]	Invalid certificate" "Invalid password	CPU, eNOR
		Login problem (OPC-UA). Human user account locking due to too many problems during the authentication attempts	1	OPC-UA	CONNECTION_FAILURE_AND_BLOCK	[meta sequen- celd=num] [auth- n@3833 itf=localPort localInterfa- cepeer= peerFQDN: peerPort user= username]	Invalid certificate, Invalid password	—
Denied login (account is blocked)	A human user tries to connect on an account already blocked.	Login problem (Web Server through HTTPS). Denied login (account is blocked)	1	HTTPS	CONNECTION_FAILURE_ON_BLOCKED	[meta sequen- celd=num] [auth- n@3833 itf=localPort localInterfa- cepeer= peerFQDN: peerPort user= username]		CPU, eNOR
		Login problem (firmware upgrade through	1	HTTPS	CONNECTION_FAILURE_	[meta sequen- celd=num] [auth- n@3833		CPU

Logged Event	Description	Additional Description	Severity	PROCID	MSGID	STRUCTURED-DATA	MSG	Devices
		HTTPS). Denied login (account is blocked)			ON_BLOCKED	itf= <i>localPort</i> <i>localInterface</i> peer= <i>peerFQDN</i> : <i>peerPort</i> user= <i>username</i>]		
		Login problem (OPC-UA). Denied login (account is blocked)	1	OPC-UA	CONNECTION_FAILURE_ON_BLOCKED	[meta sequen- celd= <i>num</i>] [auth- n@3833 itf= <i>localPort</i> <i>localInterface</i> peer= <i>peerFQDN</i> : <i>peerPort</i> user= <i>username</i>]		—
Disconnection	A human or a component disconnect manually of after a timeout due to inactivity.	HTTPS disconnection (Web Server)	6	HTTPS	DISCONNECTION	[meta sequen- celd= <i>num</i>] [auth- n@3833 itf= <i>localPort</i> <i>localInterface</i> peer= <i>peerFQDN</i> : <i>peerPort</i> user= <i>username</i>]	Manual logout	CPU, eNOR
		HTTPS disconnection (Firmware Upgrade)	6	HTTPS	DISCONNECTION	[meta sequen- celd= <i>num</i>] [auth- n@3833 itf= <i>localPort</i> <i>localInterface</i> peer= <i>peerFQDN</i> : <i>peerPort</i> user= <i>username</i>]	Manual logout	CPU, eNOR
		OPC-UA disconnection	6	OPC-UA	DISCONNECTION	[meta sequen- celd= <i>num</i>] [auth- n@3833	Socket disconnection	CPU

Logged Event	Description	Additional Description	Severity	PROCID	MSGID	STRUCTURED-DATA	MSG	Devices
						<i>itf=localPort localInterfacepeer= peerFQDN: peerPort user= username]</i>		
		Modbus disconnection	6	MODBUS	DISCONNECTION	[meta sequenceld=num] [auth-n@3833 itf=localPort localInterfacepeer= peerFQDN: peerPort user= username]	Socket disconnection	CPU
		EIP Explicit disconnection	6	EIP	DISCONNECTION	[meta sequenceld=num] [auth-n@3833 itf=localPort localInterfacepeer= peerFQDN: peerPort user= username]	Socket disconnection	CPU
		HTTP disconnection (DPWS)	6	HTTP	DISCONNECTION	[meta sequenceld=num] [auth-n@3833 itf=localPort localInterfacepeer= peerFQDN: peerPort user= username]	Socket disconnection	CPU
		HTTPS Disconnection triggered by a timeout	6	HTTPS	DISCONNECTION	[meta sequenceld=num] [auth-n@3833	Timeout logout	CPU, eNOR

Logged Event	Description	Additional Description	Severity	PROCID	MSGID	STRUCTURED-DATA	MSG	Devices
						itf= <i>localPort</i> <i>localInterface</i> peer= peerFQDN: peerPort user= username]		
		OPC-UA Disconnection triggered by a timeout	6	OPC-UA	DISCONNECTION	[meta sequenceld= <i>num</i>] [auth-n@3833 itf= <i>localPort</i> <i>localInterface</i> peer= peerFQDN: peerPort user= username]	Timeout logout	—
		DNP3 disconnection	6	DNP3	DISCONNECTION	[meta sequenceld= <i>num</i>] [auth-n@3833 itf= <i>localPort</i> <i>localInterface</i> peer= peerFQDN: peerPort user= username]	Socket disconnection	eNOR
		IEC 60870 disconnection	6	IEC60870	DISCONNECTION	[meta sequenceld= <i>num</i>] [auth-n@3833 itf= <i>localPort</i> <i>localInterface</i> peer= peerFQDN: peerPort user= username]	Socket disconnection	eNOR
Major parameter change at Run Time	Major Parameters run time change	Controller application parameters change: cycle time	6	Configuration	PARAMETER_SET	[meta sequenceld= <i>num</i>] [config@3833	Scan time	CPU

Logged Event	Description	Additional Description	Severity	PROCID	MSGID	STRUCTURED-DATA	MSG	Devices
	that can cause significant impact on the system					object="PLC application" value=value]		
Backup operation	Backup of part or total of component	Download of application from the controller	6	Backup	BACKUP	[meta sequenceld=num] [back-up@3833 object="PLC application"]		CPU
		Export of Cybersecurity Configuration from BME NUA or BME NOR web pages	6	Backup	BACKUP	[meta sequenceld=num] [back-up@3833 object="Cybersecurity configuration"]		eNOR
Restore operation	Restore of part or total of component	Upload of controller Application/ Configuration inside the controller	6	Configuration	CONFIGURATION-CHANGE	[meta sequenceld=num] [config@3833 object=Object Object = "PLC application" or "PLC configuration]		CPU
		Restore of controller application inside the controller	6	Backup	RESTORE	[meta sequenceld=num] [back-up@3833 object="PLC application"]		CPU
		Import of Cybersecurity	6	Backup	RESTORE	[meta sequenceld=num]		eNOR

Logged Event	Description	Additional Description	Severity	PROCID	MSGID	STRUCTURED-DATA	MSG	Devices
		Configuration from BME NUA or BME NOR web pages				[back-up@3833 object="Cybersecurity configuration"]		
Firmware update	A new firmware has been successfully verified and installed.	Upload of a new firmware in the device controller, Copro, Web pages	6	Configuration	FIRMWARE_UPDATE	[meta sequenceld=num] [config@3833 object=Object value=version]"Object = "Firmware", "Safety copro", "Web pages		CPU, eNOR
Invalid firmware update	A new firmware was not installed due to an error.	A new firmware was not installed because of an incompatible version or invalid signature	1	Configuration	FIRMWARE_INVALID	[meta sequenceld=num] [config@3833 object=Object value=version]"Object = "Firmware", "Safety copro", "Web pages"	Incompatible version, Invalid signature	CPU, eNOR
Modification of the time of the device	A human user request to change time and date.	—	5	Configuration	TIME_CHANGE	[meta sequenceld=num] [config@3833 object="Time" value=datetime]		CPU
Time signal out of tolerance	The component shall validate time	—	1	Configuration	TIME_UNEXPECTED	[meta sequenceld=num] [config@3833 object=	Time signal out of tolerance	

Logged Event	Description	Additional Description	Severity	PROCID	MSGID	STRUCTURED-DATA	MSG	Devices
	synchronization messages received through time synchronization channels and alarm if the time synchronization message is not within the tolerances of the component internal/ local clock (time in the past, far away, ...)					"Time" value= <i>datetime</i>]		
Hardware change	Change detected in network topology	Network physical port change: port link up/ down	6	System	HARDWARE_CHANGE	[system@3833 object= <i>Object</i>] Object = "eth" followed by decimal number	Port link up, Port link down	CPU
		Any topology change detected from RSTP / HSR / PRP	6	System	HARDWARE_CHANGE	[system@3833 object= <i>Object</i>] Object = "eth" followed by decimal number	Port enable Port disable Port learning Port forward Port blocking	CPU
	Change detected in Hardware	M580 SD card insertion/ extraction	6	System	HARDWARE_CHANGE	[system@3833 object="SDCard"]	Insertion, Extraction	CPU
Operating mode change	Program Operating Mode change	—	5	System	OPERATING_MODE_	[system@3833 object= <i>Object</i>]	"Init" "Run" "Stop" "Halt"	CPU

Logged Event	Description	Additional Description	Severity	PROCID	MSGID	STRUCTURED-DATA	MSG	Devices
	(Run, Stop, Init, halt)Mode Maintenance / SafeRun / Stop SAFE Task				CHANGE	Object = "PLC" or "PLC safe task" or "Module"	"Maintenance mode" "Safe mode" "Hsby primary" "Hsby secondary" "Hsby wait" "Master" "Non master"	
Invalid configuration (Outside Cybersecurity)	A new (not Cybersecurity) configuration was not installed due to an error.	Data integrity error (controller Application, ...)	1	Configuration	CONFIGURATION_INVALID	[meta sequenceld=num] [config@3833 object=Object value=version]"Object="PLC application" or "Module configuration"	Invalid format, Incompatible version	
Reboot	Hardware reset or automatic reset after firmware upload	—	1	System	REBOOT	—	Firmware update, Reset button	CPU
Product certificate (and/or keys) modification	Certificate Management: SL1Product Self-Signed certificate creation	—	6	Credential	CERTIFICATE_CHANGE	[meta sequenceld=num] [cred@3833 name=CommonName]	Certificate creation	CPU

NOTE: In addition to the structure described above, each message will also contain the following fields and values:

- Facility = 10
- HOSTNAME = Fully Qualified Domain Name (FQDN) or local IP address
- APPNAME = Commercial reference name, for example, BMEP584040

Example of Syslog Server Messages

Date	Time	Priority	Hostname	Message
11-08-2021	11:55:03	System0	Info	192.168.11.1 1 2021-08-26T11:22:41.000Z 192.168.11.1 BMEP585040 MODBUS CONNECTION_SUCCESS [meta sequencelid="331"]][authn@3833 if="eth" peer="192.168.11.50:52470"] Socket connection
11-08-2021	11:55:03	System0	Info	192.168.11.1 1 2021-08-26T11:22:41.000Z 192.168.11.1 BMEP585040 MODBUS CONNECTION_SUCCESS [meta sequencelid="330"]][authn@3833 if="eth" peer="192.168.11.50:52468"] Socket connection
11-08-2021	11:55:03	System0	Info	192.168.11.1 1 2021-08-26T11:22:41.000Z 192.168.11.1 BMEP585040 MODBUS CONNECTION_SUCCESS [meta sequencelid="329"]][authn@3833 if="eth" peer="192.168.11.50:52466"] Socket connection
11-08-2021	11:55:03	System0	Info	192.168.11.1 1 2021-08-26T11:22:41.000Z 192.168.11.1 BMEP585040 MODBUS CONNECTION_SUCCESS [meta sequencelid="328"]][authn@3833 if="eth" peer="192.168.11.50:52464"] Socket connection
11-08-2021	11:55:03	System0	Info	192.168.11.1 1 2021-08-26T11:22:41.000Z 192.168.11.1 BMEP585040 MODBUS CONNECTION_SUCCESS [meta sequencelid="327"]][authn@3833 if="eth" peer="192.168.11.50:52462"] Socket connection
11-08-2021	11:55:03	System0	Info	192.168.11.1 1 2021-08-26T11:22:41.000Z 192.168.11.1 BMEP585040 MODBUS CONNECTION_SUCCESS [meta sequencelid="326"]][authn@3833 if="eth" peer="192.168.11.50:52460"] Socket connection
11-08-2021	11:55:03	System0	Info	192.168.11.1 1 2021-08-26T11:22:41.000Z 192.168.11.1 BMEP585040 MODBUS CONNECTION_SUCCESS [meta sequencelid="325"]][authn@3833 if="eth" peer="192.168.11.50:52458"] Socket connection
11-08-2021	11:55:03	System0	Info	192.168.11.1 1 2021-08-26T11:22:41.000Z 192.168.11.1 BMEP585040 MODBUS CONNECTION_SUCCESS [meta sequencelid="324"]][authn@3833 if="eth" peer="192.168.11.50:52456"] Socket connection
11-08-2021	11:55:03	System0	Info	192.168.11.1 1 2021-08-26T11:22:41.000Z 192.168.11.1 BMEP585040 MODBUS CONNECTION_SUCCESS [meta sequencelid="323"]][authn@3833 if="eth" peer="192.168.11.50:52454"] Socket connection
11-08-2021	11:55:03	System0	Info	192.168.11.1 1 2021-08-26T11:22:41.000Z 192.168.11.1 BMEP585040 MODBUS CONNECTION_SUCCESS [meta sequencelid="322"]][authn@3833 if="eth" peer="192.168.11.50:52452"] Socket connection
11-08-2021	11:55:03	System0	Info	192.168.11.1 1 2021-08-26T11:22:41.000Z 192.168.11.1 BMEP585040 MODBUS CONNECTION_SUCCESS [meta sequencelid="321"]][authn@3833 if="eth" peer="192.168.11.50:52450"] Socket connection
11-08-2021	11:54:33	System0	Info	192.168.11.1 1 2021-08-26T11:22:12.000Z 192.168.11.1 BMEP585040 MODBUS CONNECTION_SUCCESS [meta sequencelid="320"]][authn@3833 if="eth" peer="192.168.11.50:52442"] Socket connection
11-08-2021	11:54:28	System0	Info	192.168.11.1 1 2021-08-26T11:22:07.000Z 192.168.11.1 BMEP585040 MODBUS CONNECTION_SUCCESS [meta sequencelid="319"]][authn@3833 if="eth" peer="192.168.11.50:34246"] Socket connection
11-08-2021	11:54:28	System0	Info	192.168.11.1 1 2021-08-26T11:22:06.000Z 192.168.11.1 BMEP585040 MODBUS CONNECTION_SUCCESS [meta sequencelid="318"]][authn@3833 if="eth" peer="192.168.11.50:52440"] Socket connection
11-08-2021	11:54:28	System0	Info	192.168.11.1 1 2021-08-26T11:22:06.000Z 192.168.11.1 BMEP585040 Configuration CONFIGURATION_CHANGE [meta sequencelid="317"]][config@3833 object="Module"]
11-08-2021	11:54:28	System0	Info	192.168.11.1 1 2021-08-26T11:22:04.000Z 192.168.11.1 BMEP585040 Configuration CONFIGURATION_CHANGE [meta sequencelid="316"]][config@3833 object="Module"]
11-08-2021	11:54:24	System0	Notice	192.168.11.1 1 2021-08-26T11:22:03.000Z 192.168.11.1 BMEP585040 System OPERATING_MODE_CHANGE [meta sequencelid="315"]][system@3833 object="PLC"] Init
11-08-2021	11:54:13	System0	Info	192.168.11.1 1 2021-08-26T11:21:51.000Z 192.168.11.1 BMEP585040 Configuration CONFIGURATION_CHANGE [meta sequencelid="314"]][config@3833 object="PLC application"]
11-08-2021	11:54:13	System0	Info	192.168.11.1 1 2021-08-26T11:21:51.000Z 192.168.11.1 BMEP585040 Backup RESTORE [meta sequencelid="313"]][backup@3833 object="PLC application"]
11-08-2021	11:54:07	System0	Info	192.168.11.1 1 2021-08-26T11:21:46.000Z 192.168.11.1 BMEP585040 MODBUS CONNECTION_SUCCESS [meta sequencelid="312"]][authn@3833 if="eth" peer="192.168.11.50:34235"] Socket connection
11-08-2021	11:53:20	System0	Info	192.168.11.1 1 2021-08-26T11:20:59.000Z 192.168.11.1 BMEP585040 Backup BACKUP [meta sequencelid="311"]][backup@3833 object="PLC application"]

Event Log Message Descriptions for M580 Controllers (Firmware earlier than Version 4.10), BMENUA0100 and BMENOR2200H (Firmware earlier than Version 3.01)

This topic presents event log message descriptions for:

- M580 controllers with firmware earlier than version 4.10 (abbreviated “CPU” in column **Devices**)
- BMENUA0100 OPC UA communication modules (abbreviated “NUA” in column **Devices**)
- BMENOR2200H remote terminal unit (abbreviated “eNOR” in column **Devices**)

Logged Event	Description	Facility	Severity	MSGID	MSG: peerAddr	MSG: type	MSG: appMsg	Devices
Successful connection to or from a tool or a device: * Successful login * Successful TCP connection	Successful login (Data Storage via FTP, FDR Server via FTP, Firmware upload via FTP)	10	6	FTP	remote ip address	Li1: Successful connection(MNT_ENG_MSG_TYP_CNCTN_SUCCESS)	"Successful login"	CPU
	Successful login (Web Server via HTTPS)			HTTPS	"(null)"		"Successful login"	NUA
	Successful login (firmware upgrade via HTTPS)			HTTPS	"(null)"		"Successful login"	NUA
	Successful login (OPC-UA)			OPC-UA	"(null)"		"Successful login"	NUA
	Successful login (Unity Application password via Modbus-Umas)			DEVICE_MANAGER	"(null)"		"Successful login"	CPU
	Successful login (Web Server via HTTP)			HTTP	"(null)"		"Successful login" OR "Successful connection" (if no User Login M580 Web pages)	CPU
	Successful TCP connection (no user)			MODBUS	remote ip address		"Successful connection"	CPU

Logged Event	Description	Facility	Severity	MSGID	MSG: peerAddr	MSG: type	MSG: appMsg	Devices
	Successful TCP connection (no user)			EIP	"(null)"		"Successful connection"	CPU
	Successful connection on DNP3 communication protocol (about DNP3 master and outstation)			DNP3	remote ip address		"Successful connection"	eNOR
	Successful connection on IEC60870 communication protocol (about IEC60870 client and server)			IEC60870	remote ip address		"Successful connection"	eNOR
Connection problem to or from a tool or a device: *TCP connection problem due to ACL check (source IP address/ TCP port filtering) * Login problem	Login problem (Data Storage via FTP, FDR Server via FTP, Firmware upload via FTP)	10	4	FTP	remote ip address	Li2: Unsuccessful connection (wrong credential) (MNT_ ENG_ MSG_ TYP_ CNCTN_ FAILURE)	"Failed login"	CPU
	Login problem (Web Server via HTTPS)			HTTPS	"(null)"		"Failed login"	NUA
	Login problem (firmware upgrade)			HTTPS	"(null)"		"Failed login"	NUA

Logged Event	Description	Facility	Severity	MSGID	MSG: peerAddr	MSG: type	MSG: appMsg	Devices
	via HTTPS)							
	Login problem (OPC-UA)			OPC-UA	"(null)"		"Failed login"	NUA
	Login problem (Web Server via HTTP)			HTTP	remote ip address		"Failed login" OR "Failed connection" (if no User Login)	CPU
	Login problem (Unity Application password via Modbus-Umas)			DEVICE_MANAGER	remote ip address		"Failed login"	CPU
	TCP connection problem (no user)			MODBUS	remote ip address		"Failed connection"	CPU
	TCP connection problem (no user)			EIP	remote ip address		"Failed connection"	CPU
	Connection problem on DNP3 communication protocol (about DNP3 master and outstation)			DNP3	remote ip address		"Failed connection"	eNOR
	Connection problem on IEC60870 communication			IEC60870	remote ip address		"Failed connection"	eNOR

Logged Event	Description	Facility	Severity	MSGID	MSG: peerAddr	MSG: type	MSG: appMsg	Devices
	protocol (about IEC60870 client and server)							
Disconnection triggered by local or peer: * TCP disconnection * On demand logout	Disconnection triggered by either the peer/user/local	10	6	FTP	"(null)"	Li5: disconnection triggered by the peer/user (MNT_ENG_MSG_TYP_DISCONNECTION)	"Disconnection"	—
	Disconnection triggered by either the peer/user/local			HTTPS	"(null)"		"Disconnection"	NUA
	Disconnection triggered by either the peer/user/local			OPC-UA	"(null)"		"Disconnection"	NUA
	Disconnection triggered by either the peer/user/local			MODBUS	remote ip address		"Disconnection"	CPU
	—			DNP3	"(null)" or remote ip address		"Disconnection"	eNOR
	—			IEC60870	"(null)" or remote ip address		"Disconnection"	eNOR
Automatic logout (inactivity timeOut) HTTPS OPC-UA	Disconnection triggered by a timeout	10	6	HTTPS	"(null)"	Li6: Disconnection triggered by a timeout (MNT_ENG_MSG_	"Auto logout"	NUA

Logged Event	Description	Facility	Severity	MSGID	MSG: peerAddr	MSG: type	MSG: appMsg	Devices
						TYP_DSCNCT_TIMEOUT)		
	Disconnection triggered by a timeout			OPC-UA			"Auto logout"	NUA
Major Changes in the system: Parameters run time change outside configuration	Major change of cycle time or watch dog controller application parameters change (cycle time, watch dog)	13	5	DEVICE_MANAGER	"(null)"	Li87: System parameter update (MNT_ENG_MSG_TYP_PARAMETER_UPDATE)	"XXXX parameter update" (with XXXX that identifies the parameter)XXXX = "Cycle time" Example: Cycle time parameter update	CPU
Major Changes in the system: * Application or Configuration download from the device	Download of a configuration file from the device	13	6	MODBUS	"(null)"	Li8: Download of a configuration file from the device (MNT_ENG_MSG_TYP_CONF_DL)	"Application download" or "Configuration download"	CPU
* Export (recording) cybersecurity configuration files from the device				HTTPS			"Cybersecurity configuration backup"	NUA
Major Changes in the system	Upload of Application/ Configuration or	13	6	MODBUS	"(null)"	Li9: Upload of a configuration file into the	"Application upload" or"	CPU NUA

Logged Event	Description	Facility	Severity	MSGID	MSG: peerAddr	MSG: type	MSG: appMsg	Devices
	Configura- tion only into the device (including CCOTF)					device (MNT_ ENG_ MSG_ TYP_ CONF_ UL)	Configura- tion upload"	
	Import (restore) cyberse- curity configura- tion file into the device			HTTPS			"Cyberse- curity configura- tion restore"	NUA
Major Changes in the system	Upload of Web pages into the device	13	6	FTP	"(null)"	Li10: Upload of a new firmware in the device (MNT_ ENG_ MSG_ TYP_ FIRM- WARE_ UPDATE)	"Web pages upload"	CPU
	Upload of new safety copro firmware			FTP			"Safety copro firmware upload"	CPU
	Upload of a new firmware in the device			FTP			"Firmware upload"	CPU
	Upload of a new firmware in the device			HTTPS			"Firmware upload"	NUA
Major Changes in the system	Modifica- tion of the time of the device	13	6	DEVICE_ MANAG- ER	"(null)"	LI15: Modifica- tion of the time of the IED	"Time major update"	NUA
Communi- cation parame- ters run time	Enable/ disable of communi- cation services	10	4	DEVICE_ MANAG- ER	"(null)"	Li18: Any port, either physical (Serial,	"Major communi- cation parameter	CPU NUA eNOR

Logged Event	Description	Facility	Severity	MSGID	MSG: peerAddr	MSG: type	MSG: appMsg	Devices
Successful change outside configuration						USB) or logical (telnet, FTP) activation/deactivation (MNT_ ENG_ MSG_ TYP_ PORT_ MANAGE- MENT)	update: XXXX YYYY"XX- XX = "EIP" or "DHCP" or "FTP" or "MOD-BUS" or "SNMP" or "HTTP" or "SECURITY" or "NTP" or "IPSEC" or "DEVICE_ MANAGER" For NUA only: XXXX = "Control Expert Data Flows to controller only" or "Control Expert Data Flows to Device Network" or "CPU to CPU Data Flows" For NOR only: XXXX = "DNP3 over TLS channel ["channel name"]" or "IE-C60870 over TLS"YYY- Y= "enable" or "disable"Example:"Major communication	

Logged Event	Description	Facility	Severity	MSGID	MSG: peerAddr	MSG: type	MSG: appMsg	Devices
							parameter update: FTP enable"	
Network physical port change: port link up/down	Any network physical port status change. Can be the simple status of a Ethernet port, or information gathered from RSTP / HSR / PRP algorithm for redundant systems	10	4	DEVICE_MANAGER	"(null)"	LI19: Any network physical port status change. Can be the simple status of a Ethernet port, or information gathered from RSTP / HSR / PRP algorithm for redundant systems (MNT_ ENG_ MSG_ TYP_ NETWK_ PORT_ CHG)	"Major network physical port status change: XXXX link YYYY" XXXX = "ETH" following by decimal number for the port or "FRONT port" YYYY = "link up" or "link down" Example: "Major network physical port status change: ETH1 link up)	CPU NUA
Any topology change detected:	Any topology change detected from RSTP / HSR / PRP	10	4	RSTP	"(null)"	LI20: Any topology change detected from RSTP / HSR / PRP algorithms for redundant systems (MNT_ ENG_ MSG_ TYP_ NTWK_ TPLGY_ CHG)	"Topology change detected" or "Topology change detected: XXXX YYYY" XXXX = "ETH" following by decimal number for the port or "FRONT port" YYYY = "enable", "disable", "learning",	CPU NUA

Logged Event	Description	Facility	Severity	MSGID	MSG: peerAddr	MSG: type	MSG: appMsg	Devices
							"forward", "blocking"	
Integrity check error:	Firmware integrity error	10	6	DEVICE_ MANAG- ER	"(null)"	LI84: Data Integrity Error MNT_ ENG_ MSG_ DATA_ INTEGRI- TY_ ERROR	"Firmware integrity error"	CPU NUA
* Digital Signature error, * Integrity only (hash mac)	Data integrity error: CS Conf, cert, whitelist, or RBAC)			DEVICE_ MANAG- ER			"Data integrity error"	NUA
Major Changes in the system: Reboot	Reboot after firmware upload	13	4	DEVICE_ MANAG- ER	"(null)"	LI14: MNT_ ENG_ MSG_ TYP_ RE- BOOT ORDER	"Restart"	CPU NUA
Major Changes in the system	Controller Operating Mode change (Run, Stop, Init, halt) Maintenance Mode Safety-related Operating Modes change (SafeRun, Stop Safe task)	13	5	DEVICE_ MANAG- ER	"(null)"	LI85: Operating mode change MNT_ ENG_ MSG_ OPERAT- ING_ MODE_ CHANGE	"XXXX state update: YYYY" (with XXXX that identifies the object which state change and YYYY that identifies the new state) XXXX = "PLC" or "PLC safe task" or "Device" YYYY = "INIT" or "STOP" or "RUN" or "HALT" or "Maintenance mode" or "Safe mode" <u>EXAM- PLES:</u>	CPU

Logged Event	Description	Facility	Severity	MSGID	MSG: peerAddr	MSG: type	MSG: appMsg	Devices
							"PLC state update: RUN" "PLC state update: Maintenance mode"	
Major Changes in the system: Hardware change	Operation on SDCard for module that have	13	6	DEVICE_MANAG-ER	"(null)"	LI26: Hardware change MNT_ ENG_ MSG_ HARD-WARE_ CHANGE	"Hardware update: XXXX" (with XXXX that describes the update) XXXX = "SD card insertion" or "SD card extraction"	CPU
	Rotary Wheel position change: Reset, Advanced			DEVICE_MANAG-ER			"Hardware update: XXXX" (with XXXX that describes the update) XXXX = "back to factory mode" or "secure mode"	NUA
Major change in Cybersecurity RBAC (done through Cybersecurity configuration web pages).	Create user account Delete user account Update user account			HTTPS	"(null)"	Li11: MNT_ ENG_ MSG_ TYP_ RBAC_UPDATE	"Update RBAC"	NUA
Major change in Cybersecurity Policy	Network services Event log	10	4	HTTPS	"(null)"	Li12: MNT_ ENG_ MSG_ TYP_	"Major cybersecurity parameter update:"	NUA

Logged Event	Description	Facility	Severity	MSGID	MSG: peerAddr	MSG: type	MSG: appMsg	Devices
(done through Cybersecurity configuration web pages).	Security policy Security banner					SECURITY_UPDATE_UPDATE	network services" "Major cybersecurity parameter update: event log" "Major cybersecurity parameter update: security policy" "Major cybersecurity parameter update: security banner"	
Major change in Cybersecurity device specific parameters (done through Cybersecurity configuration web pages).	Enable/Disable & configure IPSEC Enable/Disable & configure OPC-UA Enable/Disable & configure DNP3	10	4	HTTPS	"(null)"	Li13: MNT_ENG_MSG_TYP_DSS_UPDATE	"Major cybersecurity parameter update: IPSEC" "Major cybersecurity parameter update: OPC-UA"	NUA
Authorization problem	An action on a resource from a user or machine is not authorized	10	4	HTTPS	"(null)"	Li21: MNT_ENG_MSG_TYP_AUTH_REQ	"Failed authorization"	—
Certificate Management	Add/remove Client certificate	10	4	HTTPS	"(null)"	Li89: Certificate Management (MNT_ENG_MSG_TYP_CERT_MGT)	"Add client certificate" "Remove client certificate"	NUA

Logged Event	Description	Facility	Severity	MSGID	MSG: peerAddr	MSG: type	MSG: appMsg	Devices
Certificate Management: * Certificate expired	Server certificate expiration detection on restart	10	3	DEVICE_MANAGER	"(null)"	Li29: Certificate Management (MNT_ENG_MSG_TYP_CERT_EXPIRE)	"Certificate expired"	NUA
Specific for eNOR project:								
Authentication problem	—	10	4	"DNP3 Master" or "DNP3 Outstation"	remote ip address	Li100: MNT_ENG_MSG_TYPE_AUTHENTICATION_FAILURE	"channel ["channel name"] authentication failed"	eNOR
unexpected response	—	10	4	"DNP3 Master" or "DNP3 Outstation"	remote ip address	Li101: MNT_ENG_MSG_TYPE_UNEXPECTED_RESPONSE	"channel ["channel name"] unexpected response"	eNOR
No response	—	10	4	"DNP3 Master" or "DNP3 Outstation"	remote ip address	Li102: MNT_ENG_MSG_TYPE_NO_RESPONSE	"channel ["channel name"] no response"	eNOR
Aggressive mode not supported	—	10	4	"DNP3 Master" or "DNP3 Outstation"	remote ip address	Li103: MNT_ENG_MSG_TYPE_AGGRESSIVE_MODE_NOT_SUPPORTED	"channel ["channel name"] aggressive mode not supported"	eNOR
MAC algorithm	—	10	4	"DNP3 Master" or "DNP3_	remote ip address	Li104: MNT_ENG_	"channel ["channel name"] MAC	eNOR

Logged Event	Description	Facility	Severity	MSGID	MSG: peerAddr	MSG: type	MSG: appMsg	Devices
not supported				Outstation"		MSG_TYPE_MAC_ALGORITHM_NOT_SUPPORTED	algorithm not supported"	
Key wrap algorithm not supported	—	10	4	"DNP3 Master" or "DNP3 Outstation"	remote ip address	Li105: MNT_ENG_MSG_TYPE_KEY_WRAP_ALGORITHM_NOT_SUPPORTED	"channel ["channel name"] key wrap algorithm not supported"	eNOR
Authorization problem	—	10	4	"DNP3 Master" or "DNP3 Outstation"	remote ip address	Li86: MNT_ENG_MSG_TYP_AUTHORIZATION_FAILURE)	"channel ["channel name"] authorization failed"	eNOR
Update key change method not permitted	—	10	4	"DNP3 Master" or "DNP3 Outstation"	remote ip address	Li106: MNT_ENG_MSG_TYPE_UPDATE_KEY_CHANGE_METHOD_NOT_PERMITTED	"channel ["channel name"] update key change method not permitted"	eNOR
Invalid signature	—	10	4	"DNP3 Master" or "DNP3 Outstation"	remote ip address	Li107: MNT_ENG_MSG_TYPE_INVALID_SIGNATURE	"channel ["channel name"] invalid signature"	eNOR
Invalid certification data	—	10	4	"DNP3 Master" or "DNP3_	remote ip address	Li108: MNT_ENG_	"channel ["channel name"] invalid	eNOR

Logged Event	Description	Facility	Severity	MSGID	MSG: peerAddr	MSG: type	MSG: appMsg	Devices
				Outstation"		MSG_TYPE_INVALID_CERTIFICATION_DATA	certification data"	
Unknown User	—	10	4	"DNP3_Master" or "DNP3_Outstation"	remote ip address	Li109: MNT_ENG_MSG_TYPE_UNKNOWN_USER	"channel ["channel name"] unknown user"	eNOR
Max session key status request exceed	—	10	4	"DNP3_Master" or "DNP3_Outstation"	remote ip address	Li110: MNT_ENG_MSG_TYPE_MAX_SESSION_KEY_STATUS_REQ_EXCEED	"channel ["channel name"] max session key status request exceed"	eNOR
Session key change success	—	10	6	"DNP3_Master" or "DNP3_Outstation"	remote ip address	Li111: MNT_ENG_MSG_TYPE_SESSION_KEY_CHANGE_SUCCESS	"channel ["channel name"] session key change success"	eNOR

NOTE: In addition to the structure described above, each message will also contain the following fields and values following the Severity field:

- HOSTNAME = Local IP address or null.
- APPNAME = Commercial reference name, for example, BMEP584040.
- PROCID is not used.
- MSG:IssuerAddress = Local IP Address.
- MSG:Peer is not used.

Control Identification and Authentication

Managing Accounts

The following are best practices for account management:

- Create a standard user account with no administrative privileges.
- Use the standard user account to launch applications. Use more privileged accounts to launch an application only if the application requires higher privilege levels to perform its role in the system.
- Use an administrative level account to install applications.

Managing User Account Controls (UAC) Using Windows 10

To help minimize unauthorized PC operating system changes, Windows 10 grants applications the permission levels of a normal user with no administrative privileges. Without administrative privileges, applications cannot make changes to the system. UAC prompts the user to grant or deny additional permissions to an application. Set UAC to its maximum level. At the maximum level, UAC prompts the user before allowing an application to make any changes that require administrative permissions.

To access UAC settings in Windows 10, open **Control Panel > User Accounts and Family Safety > User Accounts > Change User Account Control Settings**, or enter **UAC** in the Windows 10 **Start Menu** search field.

Managing Passwords

Password management is one of the fundamental tools of device hardening, which is the process of configuring a device against communication-based threats. It is a good practice to apply the following password management guidelines:

- Enable password authentication on all e-mail and Web servers, controllers, and Ethernet interface modules.

- Change all default passwords immediately after installation, including those for:
 - user and application accounts on Windows, SCADA, HMI, and other systems
 - scripts and source code
 - network control equipment
 - devices with user accounts
 - FTP servers
 - SNMP and HTTP devices
 - Control Expert
- Grant passwords only to people who require access. Prohibit password sharing.
- Do not display passwords during password entry.
 - Require passwords that are difficult to guess. They should contain at least 8 characters and should combine upper and lower case letters, digits, and special characters when permitted.
- Require users and applications to change passwords on a scheduled interval.
- Remove employee access accounts when employment has terminated.
- Require different passwords for different accounts, systems, and applications.
- Maintain a secure master list of administrator account passwords so they can be quickly accessed in the event of an emergency.
- Implement password management so that it does not interfere with the ability of an operator to respond to an event such as an emergency shutdown.
- Do not transmit passwords by e-mail or other manner over the insecure Internet.

Managing HTTP

Hypertext transfer protocol (HTTP) is the underlying protocol used by the Web. It is used in control systems to support embedded Web servers in control products. Schneider Electric Web servers use HTTP communications to display data and send commands via webpages.

If the HTTP server is not required, disable it. Otherwise, use *hypertext transfer protocol secure* (HTTPS), which is a combination of HTTP and a cryptographic protocol, instead of HTTP if possible. Only allow traffic to specific devices, by implementing access control mechanisms such as a firewall rule that restricts access from specific devices to specific devices.

You can configure HTTPS as the default Web server on the products that support this feature.

Managing FTP

File transfer protocol (FTP) provides remote file handling services through a TCP/IP-based network, such as Internet. FTP uses a client-server architecture as well as separate control and data connections between the client and the server.

Consider the following behavior of the FTP service provided by Schneider Electric:

- FTP protocol is disabled by default.
- FTP protocol is necessary for specific maintenance and configuration activities only. It is a good practice to disable the entire set of FTP services when they are not required.
- FTP protocol is an unsecure protocol and must be used with care to avoid sensitive information disclosure and unauthorized access to the controllers:
 - Change the default passwords of all devices that support FTP, when possible.
 - Use Access Control List to restrict communication to the authorized IP addresses. Refer to “Cybersecurity Services Per System” for details on the concerned module.
 - When using BMENOC module, configure the IPSEC feature (*Set Up Encrypted Communication*, page 34).
 - Block all inbound and outbound FTP traffics at the boundary of the enterprise network and operations network of the control room.
 - Filter FTP commands between the control network and operations network to specific hosts or communicate them over a separate, encrypted management network.
 - Use external module to setup a VPN between the controller impacted modules and the engineering workstation on control network.
- BMENOC0301 and BMENOC0311 modules do not support IP forwarding to the device network.

If transparency is required between the control and device networks, an external router/VPN is needed to provide an encrypted communication between the control and device networks (refer to the illustration in *CSPN Security Target*, page 40).

In FTP protocol, transparency is required to perform the following operations from the control network:

- Update of M580 controller firmware from the Automation Device Maintenance.
- Network diagnostics of M580 controller executed from a network management tool through SNMP service.

Managing SNMP

Simple network management protocol (SNMP) provides network management services between a central management console and network devices such as routers, printers, and controllers. The protocol consists of three parts:

- **Manager:** an application that manages SNMP agents on a network by issuing requests, getting responses, and listening for and processing agent-issued traps.
- **Agent:** a network-management software module that resides in a managed device. The agent allows configuration parameters to be changed by managers. Managed devices can be any type of device: routers, access servers, switches, bridges, hubs, controllers, drives.
- **Network management system (NMS):** the terminal through which administrators can conduct administrative tasks.

Schneider Electric Ethernet devices have SNMP service capability for network management.

Often SNMP is automatically installed with **public** as the read string and **private** as the write string. This type of installation allows an attacker to perform reconnaissance on a system to create a denial of service.

To help reduce the risk of an attack via SNMP:

- If SNMP v1 is required, use access settings to limit the devices (IP addresses) that can access the switch. Assign different read and read/write passwords to devices.
- Change the default passwords of all devices that support SNMP.
- Block all inbound and outbound SNMP traffic at the boundary of the enterprise network and operations network of the control room.
- Filter SNMP v1 commands between the control network and operations network to specific hosts or communicate them over a separate, encrypted management network.
- Control access by identifying which IP address has privilege to query an SNMP device.
- Use an external module to set up a VPN between the controller impacted modules and the engineering workstation on the control network.

Managing Control Expert Application, Section, Data Storage, and Firmware Password

In Control Expert, passwords apply to the following (depending on the controller):

- **Application**

Control Expert and controller application protection by a password helps prevent unwanted application modification, download, or opening (.STU, .STA and .ZEF files). The password is stored encrypted in the application.

In addition to the password protection you can encrypt the .STU, .STA and .ZEF files. The file encryption feature in Control Expert helps prevent unauthorized modifications by unqualified personnel and reinforces protection against theft of intellectual property and other malicious intentions. The file encryption option is protected by a password mechanism.

NOTE: When a controller is managed as part of a system project, the application password and file encryption are disabled in Control Expert editor and need to be managed by using the Topology Manager.

More details are provided in the *Application Protection* topic (see EcoStruxure™ Control Expert, Operating Modes).

- **Section**

The section protection function is accessible from the **Properties** screen of the project in offline mode. This function is used to help protect the program sections. More details are provided in the *Section and Subroutine Protection* topic (see EcoStruxure™ Control Expert, Operating Modes).

NOTE: The section protection is not active as long as the protection is not activated in the project.

- **Data Storage/Web**

Data storage protection by a password can help prevent unwanted access to the data storage zone of the SD memory card (if a valid card is inserted in the controller). It can also help prevent unwanted access to web diagnostics (for M580 controller firmware ≥ 4.0). More details are provided in the *Data Storage Protection* topic (see EcoStruxure™ Control Expert, Operating Modes).

- **Firmware**

Firmware download protection by a password helps prevent download of malicious firmware. More details are provided in the *Firmware Protection* topic (see EcoStruxure™ Control Expert, Operating Modes).

Control Authorizations

Control Expert Security Editor

A security configuration tool is used to define software users and their respective authorizations. EcoStruxure Control Expert access security affects the terminal or terminals on which the software is installed and not the project, which has its own protection system.

For more detailed information, refer to *EcoStruxure™ Control Expert, Security Editor, Operation Guide*.

It is a good practice to establish a dedicated password to the security administrator (*SecurityAdmin*) and limit other users authorizations with a restricting profile.

Programming and Monitoring Mode

Two modes are available to access the controller in **Online** mode:

- **Programming** mode: The controller program can be modified. When a terminal is first connected to the controller, the controller becomes reserved and another terminal cannot be connected as long as the controller is reserved.
- **Monitoring** mode: The controller program cannot be modified, but the variables can be modified. The monitoring mode does not reserve the controller, and an already reserved controller can be accessed in monitoring mode.

To choose a mode in EcoStruxure Control Expert, select: **Tools > Options... > Connection > Default connection mode**.

More details on those modes are provided in the *Services in Online Mode* topic (see EcoStruxure™ Control Expert, Operating Modes).

It is a good practice to set the **Online** controller access mode to **Monitoring** whenever possible.

Program Sections Protection

The section protection function is accessible from the **Properties** screen of the project in offline mode. This function is used to protect the program sections. More details are provided in the *Section and Subroutine Protection* topic (see EcoStruxure™ Control Expert, Operating Modes).

NOTE: The section protection is not active as long as the protection has not been activated in the project.

It is a good practice to activate the sections protection.

Controller Memory Protection

The memory protection prohibits the transfer of a project into the controller and modifications in online mode, regardless of the communication channel.

NOTE: The controller memory protection cannot be configured with Hot Standby controllers. In such cases, use IPsec encrypted communication.

The memory protection is activated as follows:

- Modicon M340 controller: Input bit. For details, refer to the *Configuration of Modicon M340 processors* section (see EcoStruxure™ Control Expert, Operating Modes).
- Modicon M580 controller: Input bit. For details, refer to the *Managing Run/Stop Input* section (see Modicon M580, Hardware, Reference Manual).
- Modicon Quantum controller: Physical key switch on the controller module, either for low end (see Quantum using EcoStruxure™ Control Expert, Hardware, Reference Manual) or high end (see Quantum using EcoStruxure™ Control Expert, Hardware, Reference Manual) controller.
- Modicon Premium controller: Input bit. For details, refer to the *Configuration of Premium processors* section (see EcoStruxure™ Control Expert, Operating Modes).
- Modicon MC80 controller: Input bit. For details, refer to the Modicon MC80 controller manual.

It is a good practice to activate the controller memory protection whenever possible.

Controller Remote Run/Stop Access

The remote run/stop access management defines how a controller can be started or stopped remotely and depends on the system.

NOTE: The controller remote run/stop access cannot be configured with Hot Standby controllers. In such cases, use IPsec encrypted communication.

<p>Modicon M580:</p>	<p>Controller remote access to run/stop allows one of the following:</p> <ul style="list-style-type: none"> • Stop or run the controller remotely by request. • Stop the controller remotely by request. Rejects requests to run the controller remotely. Only a run controlled by the input is available when a valid input is configured. • Rejects requests to run or stop the controller remotely by request. <p>Refer to the <i>Managing Run/Stop Input</i> for controller configuration options that help prevent remote commands from accessing the Run/Stop modes section (see Modicon M580, Hardware, Reference Manual).</p>
<p>Modicon M340:</p>	<p>Controller remote access to run/stop allows one of the following:</p> <ul style="list-style-type: none"> • Stop or run the controller remotely by request. • Stop the controller remotely by request. Rejects requests to run the controller remotely. Only a run controlled by the input is available when a valid input is configured. <p>Refer to the <i>Configuration of Modicon M340 Processors</i> section (see EcoStruxure™ Control Expert, Operating Modes).</p>

Modicon Premium:	<p>Controller remote access to run/stop allows one of the following:</p> <ul style="list-style-type: none"> • Stop or run the controller remotely by request. • Stop the controller remotely by request. Rejects requests to run the controller remotely. Only a run controlled by the input is available when a valid input is configured. <p>Refer to the <i>Configuration of Premium\Atrium Processors section</i> (see EcoStruxure™ Control Expert, Operating Modes).</p>
Modicon Quantum:	<p>Controller remote access to run/stop allows to:</p> <ul style="list-style-type: none"> • Stop or run the controller remotely via request.
Modicon MC80:	<p>Controller remote access to run/stop allows one of the following:</p> <ul style="list-style-type: none"> • Stop or run the controller remotely by request. • Stop the controller remotely by request. Rejects requests to run the controller remotely. Only a run controlled by the input is available when a valid input is configured. • Reject running or stopping the controller remotely by request. <p>Refer to the <i>Configuration of Modicon MC80 Processors section</i> in MC80 user manual.</p>

It is a good practice to deny running or stopping the controller remotely by request.

Controller Variables Access

To help protect controller data from unauthorized read or write access, use the following best practices whenever possible:

- Use unlocated data.
- Configure EcoStruxure Control Expert to store only HMI variables: **Tools > Project Settings... > PLC embedded data > Data dictionary > Only HMI variables.**
Only HMI variables can be selected only if **Data dictionary** is selected.
- Tag as *HMI* the variables that are accessed from HMI or SCADA. Variables that are not tagged as *HMI* cannot be accessed by external clients.
- Connection with SCADA has to rely on OFS.

Data Memory Protection

You can activate data memory protection in EcoStruxure Control Expert by navigating to **Tools > Project Setting > PLC embedded data**, then select **Apply**. This feature helps protect both located and unlocated data.

For more information on the data memory protection feature, refer to the topic Data Memory Protection in the EcoStruxure Control Expert Operating Modes document.

Manage Data Integrity Checks

Introduction

The automatic integrity check feature in Control Expert helps prevent Control Expert files and software from being changed by a virus or malware. You can also launch the integrity check manually.

Automatic Integrity Check

Control Expert with Topology Manager is based on client/server architecture.

The servers are configured to start automatically when the computer is powered-on or restarted. Before the servers start, an integrity check is performed on both.

The server starts only if the integrity check completes without detecting data corruptions. If the integrity check detects data corruption, an error is logged that you can view using the **Event viewer**.

A message box indicates the corrupted files. Click **OK** and the Control Expert instance closes. For details, refer to the *EcoStruxure Control Expert Installation Manual* and the topic *Enabling Communication with Remote Clients and Reinforcing Security*.

Manual Integrity Check with Control Expert Classic

To perform a manual integrity check when an instance of Control Expert Classic is started, follow these steps:

Step	Action
1	Click Help > About Control Expert XXX .
2	<p>In the Integrity check field, click Perform self-test.</p> <p>Result: The integrity check runs in the background. Control Expert creates a log of the successful and unsuccessful component login. The log file contains the IP address, the date and time, and the result of the login.</p> <p>NOTE: If an integrity check displays an unsuccessful component login, the Event Viewer displays a message. Click OK. Manually fix the items in the log.</p>

Manual Integrity Check with Control Expert

To perform a manual integrity check when an instance of Control Expert is started, follow these steps:

Step	Action
1	Click Help > About ... in the Topology Manager toolbar.
2	<p>In the About box, click the link Perform self-test.</p> <p>Result: The integrity check runs in the background. Scans are performed on the local client servers (local or remote) that the client is connected to. The client and the servers keep running until the integrity check result is returned.</p> <p>Refer to the following table for the integrity check result consequences.</p>

IF	THEN
No data corruption is detected	The message self-test completed successfully is displayed. Click OK .
Data corruption is detected on the client	A message box indicates the corrupted files. Click OK and Control Expert client closes.
Data corruption is detected on one of the servers	The server stops. An error is logged that you can view using the Event viewer .

M580 Firmware Integrity Check

The M580 controller firmware integrity check is performed automatically after a new firmware upload or restart of the Modicon M580 PAC.

Management of SD Card

Activate the application signature in order to avoid running an incorrect application from an SD card.

The SD card signature is managed using the `SIG_WRITE` and `SIG_CHECK` functions (see *EcoStruxure™ Control Expert, Communication, Block Library*).

Configure a Secure Engineering Link between Control Expert and an M580 Ethernet Controller

Compatibility

- M580 white & grey controllers.
- Control Expert classic and Control Expert Topology Manger versions V16.0 and later.
- M580 firmware V4.20 and later.
- Control Expert Application level V4.20 and later.

Purpose of a Secure Connection

Using the software, hardware, and application versions (or later) referenced above, you can configure a secure connection between Control Expert and an M580 Ethernet controller. This connection is based on state-of-the-art Transport Layer Security (TLS) protocol and provides end-to-end secure communication.

A secure engineering link helps protect the M580 controller against cyberattack by providing:

- Controller authentication relying on a self-signed M580 certificate.
- Confidentiality by encryption of data flows between Control Expert and the M580 controller.
- Control Expert client authentication by requiring a login/password to establish the HTTPS tunnel.

A secure connection helps protect against the following network attacks:

- Replay attacks.
- Password recovery (hash).
- Application binary recovery.
- Man-in-the-middle (MITM) attacks that can modify data or the application.

Features of a Secure Connection

The following features have been added to the **Security Editor**, M580 controller firmware, and Control Expert to support the creation of a secure engineering link:

- Secure communication protocol drivers, page 100
- Three Engineering Link Modes, page 100

Communication Protocol Drivers

HTTPS and **HTTPS via USB** are new drivers that support secure engineering links.

NOTE: For clarity, two pre-existing drivers have been renamed:

- **TCPIP** is now **Modbus TCP**
- **USB** is now **Modbus TCP via USB**

Engineering Link Modes

Depending on the level of targeted cybersecurity, you can select one of the following three **Engineering Link Modes**:

- **Full Access:**

The controller behaves as in previous firmware versions. Secure and non-secure communications are accepted.

- For Control Expert communication, the controller accepts the non-secure drivers **Modbus TCP** and **Modbus TCP via USB** or secure drivers **HTTPS** and **HTTPS via USB**.
- For SCADA or controller to controller communication, **Modbus TCP** (port 502) are accepted.

- **Filtered** (default):

A hybrid mode you can use to apply cybersecurity on the engineering link, and non-secure connectivity on links to SCADA or other controllers.

- For Control Expert communication, the controller accepts the secure drivers **HTTPS** and **HTTPS via USB**.
- For SCADA or controller to controller communication, **Modbus TCP** (port 502) or **UMAS** (OFS) are accepted.

NOTE: : In **Filtered** mode, the controller accepts the unsecure drivers **Modbus TCP** and **Modbus TCP via USB** but only with **Connection mode** set to **monitoring** in the options of the project. Monitoring mode is a read only mode, where it is not possible to download an application to the controller or stop the controller.

- **Enforced** (default):

This mode provides the highest level of security. Only secure protocols are accepted by controller.

- For Control Expert communication, the controller accepts only the secure drivers **HTTPS** and **HTTPS via USB**.
- For SCADA or controller to controller communication, **Modbus TCP** (port 502) or **UMAS** (OFS) are **NOT** accepted.

Protocol Availability Summary

Each **Engineering Link Mode** option supports logical port and communication protocol combinations, as follows:

Purpose of link:		Secure Engineering Link	Non-Secure Engineering Link		HMI / SCADA
Drivers:		HTTPS or HTTPS via USB	Modbus TCP and Modbus TCP via USB		Modbus TCP/IP or UMAS
Communication Logical Port:		443	502		502
Connection mode:		Monitoring or Programming	Program- ming	Monitoring	N/A
Engineering Link Mode:	Enforced	✓	x	x	x
	Filtered	✓	x	✓	✓
	Full Access	✓	✓	✓	✓

Security Editor Whitelist

A **Certificate Whitelist** is introduced to the **Security Editor** and includes the following features:

- **Add**: Use this command to configure the IP address of the M580 controller on which you want to create a secure engineering link.
- **Get Certificate**: Use this command to retrieve HTTPS certificate from the device.
- A dialog where you can trust the certificate and add it to Windows certificate store.
- **View Certificate**: Use this command to display and verify the certificate.
- **Remove**: Use this command to remove a certificate from the whitelist.

NOTE: In this release only self-signed certificates are supported. Support of certificate from a public key infrastructure (PKI) is planned for subsequent releases.

Configure a Secure Connection Procedure

Configuring the Secure Engineering Link is accomplished using Control Expert and Security Editor, and by following the procedural tasks described below.

Preliminary Tasks

1. Upgrade your controller to V4.20 or later.
2. Upgrade Control Expert to V16.0 or later.
3. Open an existing project and change the application level to V4.20 or later, or create a new project with application level to V4.20 or later.
4. Enable HTTPS, if disabled, in the Security tab of the controller.
5. Select an Engineering Link Mode setting:
 - **Enforced:** Provides the highest level of security. Port 502 is closed on the controller. Monitoring and programming can be performed using only HTTPS connections over port 443. SCADA cannot communicate in Modbus TCP.
 - **Filtered:** Provides a hybrid mode, good balance between cybersecurity and connectivity. Monitoring and programming can be performed using HTTPS connections over port 443. Monitoring alone can be performed using Modbus TCP/IP or USB connections over port 502. SCADA can communicate in Modbus TCP.
 - **Full Access:** Programming and monitoring can be performed using Modbus TCP/IP or USB over port 502 or HTTPS connections over port 443.
NOTE: Application download time could be significantly impacted if **Full Access** mode is configured and secure drivers **HTTPS** or **HTTPS via USB** are used. If you intend to use secure drivers, consider using **Filtered** or **Enforced** mode to preserve performance.
6. Configure the definitive M580 Ethernet controller IP Address settings, if not previously done.
NOTE: Because the certificate of an M580 controller contains its IP Address, every time you change the IP Address setting, the controller renews its certificate. You will need to again trust the certificate in the Security Editor.
7. Create an Application Password for the new project.
8. Create Firmware and Web Passwords for the new project.
9. Download the application to the controller using **Modbus TCP** or **Modbus TCP via USB**.

Task 1: Trust the M580 Certificate in Security Editor

1. Open Security Editor.
2. Log in as SecurityAdmin (default password = Azertyuiop12!).
3. Change the default password of SecurityAdmin.
4. Select the **Certificate whitelist** tab.
5. Click **Add**. The **Add Connection Configuration** dialog opens.
6. Select **HTTPS** as the **Communication Protocol**. Then set **IP Address** to the configured IP Address of the controller.
7. Click **OK**.
8. Select the row corresponding to the controller.
9. Click **Trust Certificate**, then click **Yes** to add the certificate to the whitelist.
The certificate Status column is updated and indicates:
 - 'valid' = the certificate was successfully added.
 - 'unknown' = no certificate was added. Use the tooltip to view the detected error details.
10. If certificate is valid, click the ellipsis (...) to display its device name and details.

Task 2: Configure a Secure Connection

1. Select **PLC > Set Address...** in Control Expert.
2. In the PLC area, enter either the M580 controller's IP address, or 90.0.0.1 if you are using a USB cable
3. In the **Communication Protocol** area, select **HTTPS** or **HTTPS via USB**.
4. Click **OK**
5. In Control Expert, select **PLC > Connect**.
6. Enter the Application password.

Operating Mode Considerations

Out-of-the-Box Communication

When you first start-up a new out-of-the-box M580 controller, the following restrictions are applied:

- An HTTPS connection between Control Expert and the M580 controller is not supported.
- Communication is possible only by using USB or TCPIP.

Reset M580 Controller to NOCONF

You can switch your M580 controller to the NOCONF in the following ways:

- Use the rotary wheel on a Hot Standby M580 controller.
- Use the rotary wheel on the grey M580 controller.
- Use an SD Card as follows:
 1. Create an application without a password.
 2. Load the application into another M580 controller of the same reference.
 3. Insert the SD card into the other controller.
 4. Set %S66 to backup application on the SD card.
 5. Insert SD card into the original M580 controller and cycle power to the controller.
- Setup the M580 controller on slot 1.

Reset the Application Password

Reset the Application password procedure through L3 support is still available in **Filtered** and **Full Access Engineering Link Mode**, but not in **Enforced** mode.

Application Password change on-the-fly (an online modification) is supported.

Enforced Secure Programming Compatibility and Limitations

Compatibility

Refer to the topic [Configure a Secure Engineering Link between Control Expert and an M580 Ethernet Controller](#), page 99.

Engineering Link Mode Limitations

For any physical connection, the following limitations apply to the **Enforced Engineering Link Mode** option:

- The Data Dictionary feature is not functional.
- M580 Safety (red) controllers are not supported in V4.20. Support is planned for V4.21 and later..
- BMENUA0100 diagnostics are not supported.
- Application download via BMENUA0100 IP Address is not recommended.
- Upgrade to M580 Ethernet controller firmware is possible only for non-safety controllers with firmware greater than version 3.
- The controller is not accessible using the following function blocks:
 - READ_VAR
 - WRITE_VAR
 - DATA_EXCH
 - READ_REMOTE
- The controller cannot be scanned by a Modbus scanner.
- The M580 controller's Modbus scanner cannot scan Modbus devices.

- Depending on the selected communication protocol (Modbus TCP or EtherNet/IP), some DTM diagnostic services are not available, as follows:

DTM Services	Protocol	Availability
EtherNet/IP DTM Connect	EtherNet/IP	✓
EtherNet/IP DTM Disconnect	EtherNet/IP	✓
Modbus DTM Connect	Modbus TCP	✗
Modbus DTM Disconnect	Modbus TCP	✗
Ethernet Diagnostic	EtherNet/IP	✓
Bandwidth Diagnostic	Modbus TCP	✗
RSTP Diagnostic	Modbus TCP	✗
Network Time Service Diagnostic	EtherNet/IP	✓

Communication Adapter Compatibility

The following matrix summarizes services available on a controller or communication adaptor depending on the selected engineering mode.

The rows correspond to the available services:









- Engineering Link: The connection between Control Expert and the controller.
- Client Mode communication: Scanner, Modbus, EtherNet/IP (implicit or explicit), OPCUA, DNP3, IEC 61850.
- Server Mode communication: Modbus, EtherNet/IP, OPCUA, DNP3, IEC 61850

The columns correspond to the different possible configurations. For example:



- Controller alone: a controller is used without any communication adaptor.
- Controller+NOC with Backplane On: a controller and a BMENOC03** exist in the main rack; the backplane port of the BMENOC03** is enabled; Control Expert is connected to the BMENOC03**.
- Controller+NOC backplane off: a controller and a BMENOC03** exist in the main rack; the backplane port of the BMENOC03** is disabled; Control Expert is connected to the BMENOC03**.
- and so forth...

When a communication adaptor is used, some services are available on the communication adaptor itself or from the controller through the communication adaptor. To distinguish these two cases the letter "C" for controller and "M" for module are used. For example:

- The connection from Control Expert to the controller can be made using the IP address of the controller, in this case the letter "C" applies.
- But, if the connection from Control expert is made using the IP address of the BMENUA0100, the letter "M" in the column related to the module (in this case a BMENUA0100) applies.

Engineering Link			Controller Alone	Controller + NOCs (NOC301, NOC311, NOC321)	Controller + NOCs (NOC301, NOC311, NOC321)	Controller + NOC321	Controller + NUA (Sec mode)	Controller + BMXNOR	Controller + BMENOR step3	Controller + NOP	Controller + NOP																																																																																																																																																																																																																																						
------------------	--	--	------------------	--	--	---------------------	-----------------------------	---------------------	---------------------------	------------------	------------------	---	---	---	---	---	---	---	---	---	---	---	---	---	---	---	---	---	---	---	---	---	---	---	---	---	---	---	---	---	---	---	---	---	---	---	---	---	---	---	---	---	---	---	---	---	---	---	---	---	---	---	--	--	--	--	--	--	--	--	--	--	--	--	--	--	--	--	--	--	--	--	--	--	--	--	--	--	--	--	--	--	--	--	--	--	--	--	--	--	--	--	--	--	--	--	--	--	--	--	--	--	--	--	--	--	--	--	--	--	--	--	--	--	--	--	--	--	--	--	--	--	--	--	--	--	--	--	--	--	--	--	--	--	--	--	--	--	--	--	--	--	--	--	--	--	--	--	--	--	--	--	--	--	--	--	--	--	--	--	--	--	--	--	--	--	--	--	--	--	--	--	--	--	--	--	--	--	--	--	--	--	--	--	--	--	--	--	--	--	--	--	--	--	--	--	--	--	--	--	--	--	--	--	--	--	--	--	--	--	--	--	--	--	--	--	--	--	--	--	--	--	--	--	--	--	--	--	--	--	--

		Controller + NOCs (NOC301, NOC311, NOC321)															Controller + NOC321			Controller + NUA (Sec mode)			Controller + BMXNOR			Controller + BMENOR step3			Controller + NOP			Controller + NOP		
		Backplane Port Enabled															Backplane Port Disabled			IP Forwarding			Backplane Isolated			Backplane Port Disabled			Backplane Port Enabled w/ IP Forwarding			Backplane Port Disabled IP Forwarding		
Server Mode	Modbus Server / UMAS	C	C	X	M	M	X	M	M	X	C	C	X	C*	C*	X	M	M	X	M**	M**	X	C	M	C	M	X	M	M	X				
		C	C	C	M	M	C	C	C	C	C	C	C	C*	C*	C*	M	M	X	M	M	X	C	C	C	M	X	M	M	X				
		C	C	C	C	C	C	C	C	C	C	C	C	C*	C*	C*	M	M	X	M	M	X	C	C	C	M	X	M	M	X				
		C	C	C	C	C	C	C	C	C	C	C	C	C*	C*	C*	M	M	X	M	M	X	C	C	C	M	X	M	M	X				
		C	C	C	C	C	C	C	C	C	C	C	C	C*	C*	C*	M	M	X	M	M	X	C	C	C	M	X	M	M	X				
		C	C	C	C	C	C	C	C	C	C	C	C	C*	C*	C*	M	M	X	M	M	X	C	C	C	M	X	M	M	X				
		C	C	C	C	C	C	C	C	C	C	C	C	C*	C*	C*	M	M	X	M	M	X	C	C	C	M	X	M	M	X				
Client Mode		C	C	X	C	C	X	C	C	X	C	C	X	C*	C*	X	C	C	X	C	C	X	C	C	X	C	C	X	C	C	X			
	IEC 61850	-	-	-	-	-	-	-	-	-	-	-	-	-	-	-	-	-	-	-	-	-	-	-	-	-	-	-	-	-				
	DNP3 IEC 60870	-	-	-	-	-	-	-	-	-	-	-	-	-	-	-	-	-	-	-	-	-	-	-	-	-	-	-	-	-				
	EFB OPCUA	C	C	C	-	-	-	-	-	-	C	C	C	C*	C*	C*	-	-	-	-	-	-	-	C	C	C	C	C	C	C				
	EFB EIP	C	C	C	C	C	C	C	C	C	C	C	C	C	C	C	C	C	C	C	C	C	C	C	C	C	C	C	C	C				
	EFB Modbus	C	C	X	C	C	X	C	C	X	C	C	X	C*	C*	X	C	C	X	C	C	X	C	C	X	C	C	X	C	C	X			
	EIP Scanner	C	C	C	C	M	M	M	M	M	C	C	C	C*	C*	C*	-	-	-	-	-	-	C	C	C	-	-	-	-	-				
	IO scanner Modbus	C	C	X	C	M	M	M	M	M	C	C	M	C*	C*	X	-	-	-	-	-	-	C	C	X	-	-	-	-	-				

Symbol	Description
	Engineering Link Mode set to Full Access
	Engineering Link Mode set to Filtered
	Engineering Link Mode set to Enforced
C	<ul style="list-style-type: none">In client mode "C" indicates the communication is initiated by the controller.In server mode "C" indicates the destination IP address is the controller.
M	<ul style="list-style-type: none">In client mode "M" indicates the communication is initiated by communication adaptor.In server mode "M" indicates the destination IP address is the communication adaptor. <p>In both cases the module communicates with the controller over XBUS.</p>
X	Not supported
*	Depending on forwarding rules configured in the BMENUA0100 module.
**	If the Modbus server is enabled in the BMENOR00200
-	Not Applicable

M580 Ethernet Services and Ports

This topic presents the M580 Ethernet services available and their status by default in the Control Expert application.

“Out of box” indicates the configuration applies to a CPU from the factory, with no application inside. Once an application has been loaded in the controller, this state can never again be achieved.

“Default” indicates the configuration applies to a default Control Expert application.

M580 Controllers with Firmware Version < 4.01

Service	Port number	Out of box	Default	Notes
HTTP	80/tcp	Closed	Closed	Web
Modbus TCP	502/tcp	Open	Open	
EtherNet/IP	44818/tcp-udp	Closed*	Closed*	EtherNet/IP Explicit (Class 3)
DHCP	67/udp	Closed*	Closed*	
FTP	21/tcp	Open	Closed	Firmware, data storage, FDR
TFTP	69/udp	Closed	Closed	FDR (X80)
SNMP	161/udp	Closed*	Closed*	
EtherNet/IP	2222/udp	Closed	Closed*	EtherNet/IP implicit (Class 1)
NTP/SNTP	123/udp	Closed	Closed*	NTPV4 or SNTP

Closed*: Can appear as filtered depending on Nmap configuration.

M580 Controllers with Firmware Version ≥ 4.01

Service	Port number	Out of box	Default	Notes
HTTPS	443/tcp	Open	Open	Web, firmware, data storage
Modbus TCP	502/tcp	Open	Open	
EtherNet/IP	44818/tcp-udp	Closed*	Closed*	EtherNet/IP Explicit (Class 3)
DHCP	67/udp	Closed*	Closed*	
FTP	21/tcp	Closed	Closed	FDR

Service	Port number	Out of box	Default	Notes
TFTP	69/udp	Closed	Closed*	FDR (X80)
SNMP	161/udp	Closed*	Closed*	
EtherNet/IP	2222/udp	Closed	Closed*	EtherNet/IP implicit (Class 1)
NTP/SNTP	123/udp	Closed	Closed	NTPV4 or SNTP
WS-Discovery	3702/udp	Closed	Closed*	Firmware update
DPWS	9867/tcp	Open	Open	Firmware update

Closed*: Can appear as filtered depending on Nmap configuration.

Physical Port Connections

Each **Engineering Link Mode** option presents physical port connection requirements.

Physically Connecting Control Expert to the M580 Ethernet Controller

In any **Engineering Link Mode**, you can physically connect your engineering PC running Control Expert to the M580 Ethernet controller using the following physical ports:

- The M580 controller service port
- If the M580 controller backplane port is enabled: a Control port of one of the following communication modules placed in the main local backplane:
 - BMENOR2200
 - BMENOR2200.2
 - BMENOC301
 - BMENOC311
 - BMENOC321 with IP Forwarding enabled
 - BMENUA0100 version 2.01 or later with IP Forwarding enabled

Cybersecurity Services Per System

Introduction

This chapter lists the main cybersecurity services available per system and indicates where to find detailed information in Control Expert help.

Cybersecurity Services

Overview

Software, DTM, or devices are elements providing cybersecurity services in a global system. The available cybersecurity services are listed for the following elements:

- Control Expert software, page 115
- Modicon M340 controller, page 115
- Modicon M580 controller, page 116
- Modicon Momentum (Cybersecurity services are not implemented.)
- Modicon Quantum controller and communication modules, page 117
- Modicon X80 modules, page 118
- Modicon Premium/Atrium controller and communication modules, page 119

The cybersecurity services listed below are described in previous chapter:

- Disable unused services, page 30
- Access control, page 31
- Set Up Encrypted Communication, page 34
- Event logging, page 48
- Authentication, page 89
- Authorizations, page 93
- Integrity checks, page 97

Cybersecurity Services in Unity Pro/Control Expert Software

Unity Pro is the former name of Control Expert for version 13.1 or earlier.

Cybersecurity services availability

Software	Cybersecurity services							
Reference	Disable unused services	Access control	Encrypted communication	Encrypted communication with confidentiality	Event logging	Authentication	Authorizations	Integrity checks
Unity Pro v8.1	–	N.A.	–	–	–	X	X	X
Unity Pro≥v10.0	–	N.A.	X	–	X	X	X	X
Unity Pro≥v13.0	–	N.A.	X	X	X	X	X	X
Control Expert≥v14.0	X	X	X	X	X	X	X	X

X Available, at least one service is implemented.
 – Not available
N.A. Not applicable

There are more robust password recovery mechanisms available when using Control Expert versions greater than or equal to v.15.1 targeting applications for M580 firmware versions greater than or equal to v4.01.

Cybersecurity Services in Modicon M340 Controller

Minimum firmware version and cybersecurity services availability in Modicon M340 controller:

Controller		Cybersecurity services						
Reference	Min. firm-ware	Disable unused services	Access control	Encryp-ted communi-cation	Event logging	Authenti-cation	Authori-zations	Integrity checks
BMX P34 1000	2.60	–	–	–	–	X	X	–
BMX P34 2000	2.60	–	–	–	–	X	X	–
BMX P34 2010	2.60	–	–	–	–	X	X	–
BMX P34 20102	2.60	–	–	–	–	X	X	–
BMX P34 2020	2.60	X	X	–	–	X	X	–
BMX P34 2030	2.60	X	X	–	–	X	X	–
BMX P34 20302	2.60	X	X	–	–	X	X	–

X Available, at least one service is implemented.
 – Not available

Cybersecurity Services in Modicon M580 Controller:

Minimum firmware version and cybersecurity services availability in Modicon M580 controller:

Controller		Cybersecurity services						
Reference	Min. firm-ware	Disable unused services	Access control	Encrypted communi-cation	Event logging	Authenti-cation	Authori-zations	Integrity checks
BME P58 1020	1.00	X	X	–	X	X	X	X
BME P58 2020	1.00	X	X	–	X	X	X	X
BME P58 2040	1.00	X	X	–	X	X	X	X
BME P58 3020	1.00	X	X	–	X	X	X	X
BME P58 3040	1.00	X	X	–	X	X	X	X
BME P58 4020	1.00	X	X	–	X	X	X	X
BME P58 4040	1.00	X	X	–	X	X	X	X
BME P58 5040	2.10	X	X	–	X	X	X	X
BME P58 6040	2.10	X	X	–	X	X	X	X
BME H58 2040	2.10	X	X	–	X	X	X	X
BME H58 4040	2.10	X	X	–	X	X	X	X

Controller		Cybersecurity services						
Reference	Min. firm-ware	Disable unused services	Access control	Encrypted communi-cation	Event logging	Authenti-cation	Authori-zations	Integrity checks
BME H58 6040	2.10	X	X	–	X	X	X	X
<p>X Available, at least one service is implemented.</p> <p>– Not available</p>								

Cybersecurity Services in Modicon Quantum Controller and Modules

Minimum firmware version and cybersecurity services availability in Modicon Quantum controller:

Controller		Cybersecurity services						
Reference	Min. firm-ware	Disable unused services	Access control	Encryp-ted communi-cation	Event logging	Authenti-cation	Authori-zations	Integrity checks
140CPU31110	3.20	–	–	–	–	X	X	–
140CPU43412•	3.20	–	–	–	–	X	X	–
140CPU53414•	3.20	–	–	–	–	X	X	–
140CPU651•0	3.20	X	X	–	–	X	X	–
140CPU65260	3.20	X	X	–	–	X	X	–
140CPU65860	3.20	X	X	–	–	X	X	–
140CPU67060	3.20	X	X	–	–	X	X	–
140CPU67160	3.20	X	X	–	–	X	X	–
140CPU6726•	3.20	X	X	–	–	X	X	–
140CPU67861	3.20	X	X	–	–	X	X	–
<p>X Available, at least one service is implemented.</p> <p>– Not available</p>								

Modicon Quantum modules supporting cybersecurity services:

Module		Cybersecurity services						
Reference	Min. firm-ware	Disable unused services	Access control	Encrypted communication	Event logging	Authent-ication	Authori-zations	Integrity checks
140NOC7710•	1.00	–	X	–	–	X	–	–
140NOC78000	2.00	X	X	–	–	X	–	–
140NOC78100	2.00	X	X	–	–	X	–	–
140NOE771••	X	X	–	–	–	X	–	–
140NWM10000	–	X	–	–	–	–	–	–
<p>X Available, at least one service is implemented.</p> <p>– Not available</p>								

Cybersecurity Services in Modicon X80 Modules

Modicon X80 modules supporting cybersecurity services:

Module		Cybersecurity services							
Reference	Min. firm-ware	Disable unused serv-ices	Access control	Encryp-ted commu-nication	Encryp-ted commu-nication with confi-dentiali-ty	Event logging	Authen-tication	Authori-zations	Integrity checks
BMECXM0100	1.01	X	X	–	–	X	–	–	X
BMENOC0301	1.01	X	X	X	–	X	X	–	X
BMENOC0311	1.01	X	X	X	–	X	X	–	X
BMXNOC0401.2	2.05	X	X	–	–	–	–	–	–
BMXNOE0100.2	2.90	X	X	–	–	–	–	–	–
BMXNOE0110.2	6.00	X	X	–	–	–	–	–	–
BMXPRA0100	2.60	X	X	–	–	–	X	–	–
BMENOC0301	2.11	X	X	X	X	X	X	–	X
BMENOC0311	2.11	X	X	X	X	X	X	–	X
BMXNOR0200H									

Module		Cybersecurity services							
Reference	Min. firm-ware	Disable unused serv-ices	Access control	Encryp-ted communi-cation	Encryp-ted communi-cation with confi-dentiali-ty	Event logging	Authenti-cation	Authori-zations	Integrity checks
BMENOR2200H									
<p>X Available, at least one service is implemented.</p> <p>– Not available</p>									

Cybersecurity Services in Modicon Premium/Atrium Controller and Modules

Minimum firmware version and cybersecurity services availability in Modicon Premium/ Atrium controller:

Controller		Cybersecurity services						
Reference	Min. firm-ware	Disable unused services	Access control	Encrypted communi-cation	Event logging	Authenti-cation	Authori-zations	Integrity checks
TSXH57•4M	3.10	–	–	–	–	X	X	–
TSXP570244M	3.10	–	–	–	–	X	X	–
TSXP57•04M	3.10	–	–	–	–	X	X	–
TSXP57•54M	3.10	–	–	–	–	X	X	–
TSXP571634M TSXP572634M TSXP573634M (through ETY port)	3.10	X	X	–	–	X	X	–

Controller		Cybersecurity services						
Reference	Min. firm-ware	Disable unused services	Access control	Encrypted communication	Event logging	Authenti-cation	Authori-zations	Integrity checks
TSXP574634M TSXP575634M TSXP576634M (embedded Ethernet port)	3.10	X	X	–	–	X	X	–
<p>X Available, at least one service is implemented.</p> <p>– Not available</p>								

Modicon Premium/Atrium modules supporting cybersecurity services:

Module		Cybersecurity services						
Reference	Min. firm-ware	Disable unused services	Access control	Encrypted communication	Event logging	Authenti-cation	Authori-zations	Integrity checks
TSXETC101.2	2.04	X	X	–	–	–	–	–
TSXETY4103	5.70	X	X	–	–	–	–	–
TSXETY5103	5.90	X	X	–	–	–	–	–
<p>X Available, at least one service is implemented.</p> <p>– Not available</p>								

Modicon M340 Security Services

Overview

Communication security services settings description is provided for the Modicon M340 controller in different manuals as described in the following topic.

Modicon M340 Controller with Embedded Ethernet Ports

Description of communication parameters related to cybersecurity is provided in the listed topics:

Ethernet communication:	Refer to <i>Security</i> section (see Modicon M340 for Ethernet, Communications Modules and Processors, User Manual).
Access control:	Refer to <i>Messaging Configuration Parameters</i> section (see Modicon M340 for Ethernet, Communications Modules and Processors, User Manual).

Modicon M580 Security Services

Modicon M580 Controller

Description of communication parameters related to cybersecurity is provided in the topic that describes the *Security Tab* (see Modicon M580, Hardware, Reference Manual).

Modicon Quantum Security Services

Overview

Communication security services settings description is provided for the Modicon Quantum controller and Ethernet modules in different manuals as described in the following topics.

Modicon Quantum Controller with Embedded Ethernet Ports

Description of communication parameters related to cybersecurity is provided in the listed topics:

Ethernet communication:	Refer to <i>Security (Enable / Disable HTTP, FTP, and TFTP)</i> section (see Quantum using EcoStruxure™ Control Expert, Ethernet Network Modules, User Manual).
Access control:	Refer to <i>Modicon Quantum with Control Expert Ethernet Controller Messaging Configuration</i> section (see Quantum using EcoStruxure™ Control Expert, Ethernet Network Modules, User Manual).

140 NOC 771 0x Module

Description of communication parameters related to cybersecurity is provided in the listed topics:

Ethernet communication:	Refer to <i>Security (Enable / Disable HTTP, FTP, and TFTP)</i> section (see Quantum using EcoStruxure™ Control Expert, Ethernet Network Modules, User Manual).
Access control:	Refer to <i>Configuring Access Control</i> section (see Quantum using EcoStruxure™ Control Expert, 140 NOC 771 01 Ethernet Communication Module, User Manual).

140 NOC 780 00 Module

Description of communication parameters related to cybersecurity is provided in the listed topics:

Ethernet communication:	Refer to <i>Security</i> section (see Quantum EIO, Control Network, Installation and Configuration Guide).
Access control:	Refer to <i>Configuring Access Control</i> section (see Quantum EIO, Control Network, Installation and Configuration Guide).

140 NOC 781 00 Module

Description of communication parameters related to cybersecurity is provided in the listed topics:

Ethernet communication:	Refer to <i>Security</i> section (see Quantum EIO, Control Network, Installation and Configuration Guide).
Access control:	Refer to <i>Configuring Access Control</i> section (see Quantum EIO, Control Network, Installation and Configuration Guide).

140 NOE 771 xx Module

Description of communication parameters related to cybersecurity is provided in the listed topics:

Ethernet communication:	Refer to <i>Security (Enable / Disable HTTP, FTP, and TFTP)</i> section (see Quantum using EcoStruxure™ Control Expert, Ethernet Network Modules, User Manual), <i>Security</i> section (see Quantum using EcoStruxure™ Control Expert, Ethernet Network Modules, User Manual), and <i>Establishing HTTP and Write Passwords</i> section (see Quantum using EcoStruxure™ Control Expert, Ethernet Network Modules, User Manual).
-------------------------	--

140 NWM 100 00 Module

Description of communication parameters related to cybersecurity is provided in the listed topics:

Ethernet communication:	Refer to <i>Security (Enable / Disable HTTP, FTP, and TFTP)</i> section (see Quantum using EcoStruxure™ Control Expert, Ethernet Network Modules, User Manual).
-------------------------	---

Modicon X80 Security Services

Overview

Communication security services settings description is provided for the Modicon X80 Ethernet modules in different manuals as described in the following topics.

BMXNOC0401.2 Module

A description of communication parameters related to cybersecurity is provided in the listed topics:

Ethernet communication:	Refer to the <i>Security</i> section (see Modicon M340 for Ethernet, Communications Modules and Processors, User Manual).
Access control:	Refer to the <i>Configuring Access Control</i> section (see Modicon M340, BMX NOC 0401 Ethernet Communication Module, User Manual).

BMXNOE0100.2 and BMXNOE0110.2 Module

A description of communication parameters related to cybersecurity is provided in the listed topics:

Ethernet communication:	Refer to the <i>Security</i> section (see Modicon M340 for Ethernet, Communications Modules and Processors, User Manual).
Access control:	Refer to the <i>Messaging Configuration Parameters</i> section (see Modicon M340 for Ethernet, Communications Modules and Processors, User Manual).

BMXPRA0100 Module

The BMXPRA0100 module is configured as an Modicon M340 controller. A description of communication parameters related to cybersecurity is provided in the listed topics:

Ethernet communication:	Refer to the <i>Security</i> topic (see Modicon M340 for Ethernet, Communications Modules and Processors, User Manual).
Access control:	Refer to the <i>Messaging Configuration Parameters</i> topic (see Modicon M340 for Ethernet, Communications Modules and Processors, User Manual).

BMXNOR0200H Module

A description of communication parameters related to cybersecurity is provided in the listed topics:

Ethernet communication:	Refer to the <i>Security</i> topic (see Modicon X80 , BMXNOR0200H RTU Module, User Manual).
Access control:	Refer to the <i>Messaging Configuration Parameters</i> topic.

BMENOR2200H Module

A description of communication parameters related to cybersecurity is provided in the listed topics:

Ethernet communication:	Refer to the <i>Security</i> topic.
Access control:	Refer to the <i>Messaging Configuration Parameters</i> topic.

BMECXM0100 Module

A description of communication parameters related to cybersecurity is provided in the *Ethernet Services Configuration* chapter (see Modicon M580, BMECXM CANopen Modules, User Manual).

BMENOC0301 and BMENOC0311 Modules

A description of communication parameters related to cybersecurity is provided in the *Configuring Security Services* topic (see Modicon M580 BMENOC0301/0311, Ethernet Communications Module, Installation and Configuration Guide).

BMENUA0100 Module

A description of communication parameters related to cybersecurity is provided in the listed topics:

Ethernet communication:	Refer to the Cybersecurity Settings topic (see M580, BMENUA0100 OPC UA Embedded Module, Installation and Configuration Guide).
Access control:	Refer to the <i>Access Control</i> topic.

Modicon Premium/Atrium Security Services

Overview

Communication security services settings description is provided for the Modicon Premium/Atrium controller and Ethernet modules in different manuals as described in the following topics.

Modicon Premium/Atrium Controller with Embedded Ethernet Ports

Description of communication parameters related to cybersecurity is provided in the listed topics:

Ethernet communication:	Refer to <i>Security Service Configuration Parameters</i> section (see Premium and Atrium Using EcoStruxure™ Control Expert, Ethernet Network Modules, User Manual).
Access control:	Refer to <i>Configuration of TCP/IP Messaging (TSX P57 6634/5634/4634)</i> section (see Premium and Atrium Using EcoStruxure™ Control Expert, Ethernet Network Modules, User Manual).

Modicon Premium/Atrium Controller through ETY Ports

Description of communication parameters related to cybersecurity is provided in the listed topics:

Ethernet communication:	Refer to <i>Security Service Configuration Parameters</i> section (see Premium and Atrium Using EcoStruxure™ Control Expert, Ethernet Network Modules, User Manual).
Access control:	Refer to <i>Configuration of TCP/IP Messaging</i> section (see Premium and Atrium Using EcoStruxure™ Control Expert, Ethernet Network Modules, User Manual).

TSX ETC 101.2 Module

Description of communication parameters related to cybersecurity is provided in the listed topics:

Ethernet communication:	Refer to <i>Security</i> section (see Premium using EcoStruxure™ Control Expert, TSX ETC 101 Ethernet Communication Module, User Manual).
Access control:	Refer to <i>Configuring Access Control</i> section (see Premium using EcoStruxure™ Control Expert, TSX ETC 101 Ethernet Communication Module, User Manual).

TSX ETY x103 Module

Description of communication parameters related to cybersecurity is provided in the listed topics:

Ethernet communication:	Refer to <i>Security Service Configuration Parameters</i> section (see Premium and Atrium Using EcoStruxure™ Control Expert, Ethernet Network Modules, User Manual).
Access control:	Refer to <i>Configuration of TCP/IP Messaging</i> section (see Premium and Atrium Using EcoStruxure™ Control Expert, Ethernet Network Modules, User Manual).

How to help protect M580 and M340 architectures with EAGLE40 using VPN

Introduction

This chapter explains how to help increase protection of controllers against cyber attacks by relying on a firewall device such as the EAGLE40-07 from Belden, configured to establish VPN connections. Deploying such device in an architecture can help mitigate vulnerabilities existing in the devices and help reduce the attack surface of different products.

It is a good practice to harden the network, workstations and devices, as described in the *Modicon Controller Systems CyberSecurity, User Guide* available for download at: <https://www.se.com/ww/en/download/document/EIO0000001999/>

EAGLE40 Firewall

Why use a Firewall?

Relying on a firewall to reinforce the cybersecurity of an existing architecture brings the following advantages:

- The cybersecurity of control networks and devices is reinforced.
- Reinforced cybersecurity relies on the IPSEC protocol.
- Impact on existing architecture and performances can be minimized.

EAGLE40 Main Features

The EAGLE40 firewall is a solution to cover or mitigate cybersecurity residual issues.

- Through powerful IPSEC VPN, EAGLE40 firewall provides expected confidentiality on network traffic to help prevent attacks conducted by "Man in the middle" way. It also ensures the authentication of the sender by helping to prevent from "spoofing" attacks. Message integrity is also reinforced by cryptographic methods and cannot be tampered any more.
- Usual filtering capabilities are also available, allowing to control traffic and protocols based on IP, Mac address, and port of network devices.
- The EAGLE40 firewall is a scalable product that can be included in multi-point architectures, with rate and bandwidth performances ensuring network transparency.

Prerequisites

Software Installation

A compatible VPN client software is necessary to establish a VPN tunnel based on IPSEC protocol between the client and the firewall.

The EAGLE40 firewall requires the use of the VPN client IPSEC/IKEV2.

NOTE: Use the VPN client solution provided by TheGreenBow.

In the configuration procedures described below we use this software that you can download at the following URL:

- https://www.thegreenbow.fr/vpn_client.html, for Windows.
- https://www.thegreenbow.fr/vpn_linux.html, for Linux

Machines and Operating Systems

Before configuring the firewall, you need to prepare all IP address in use in the architectures.

The following diagram is given as an example:

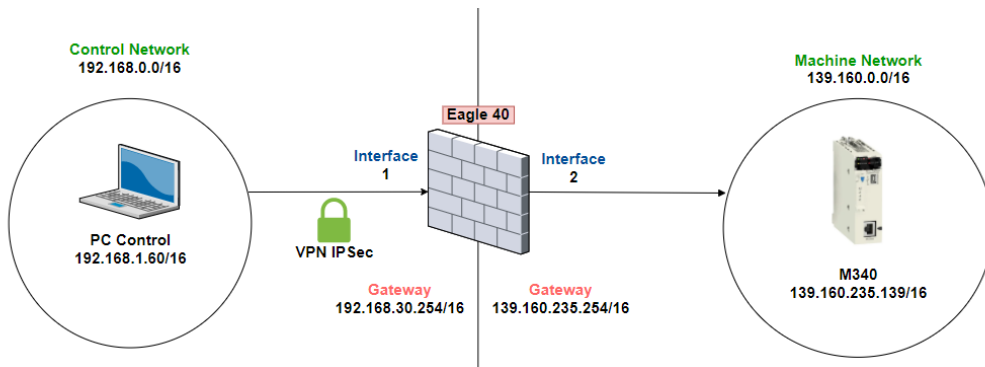

Typical Architecture

The architecture and configuration instructions in this document are provided as examples and can be adapted to various architectures and systems.

As an example, the following mixed architecture, combining both Modicon M340 and Modicon M580 controllers is a typical architecture:

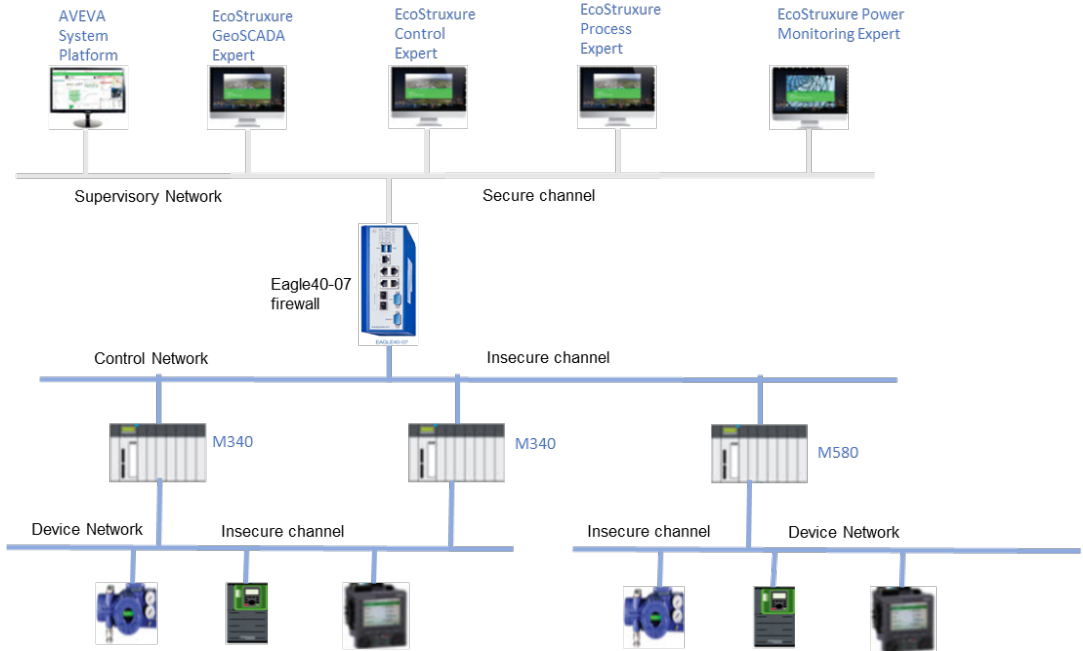

Configuring the Firewall

Web Configuration

To configure the firewall, open an Internet browser and enter the following URL:



`https://[IPFirewall]/admin`

Click **Enter** and use default username/password combination `admin/private` to log in.

NOTE: On the first login you are required to change the password.

Configuring the Routes

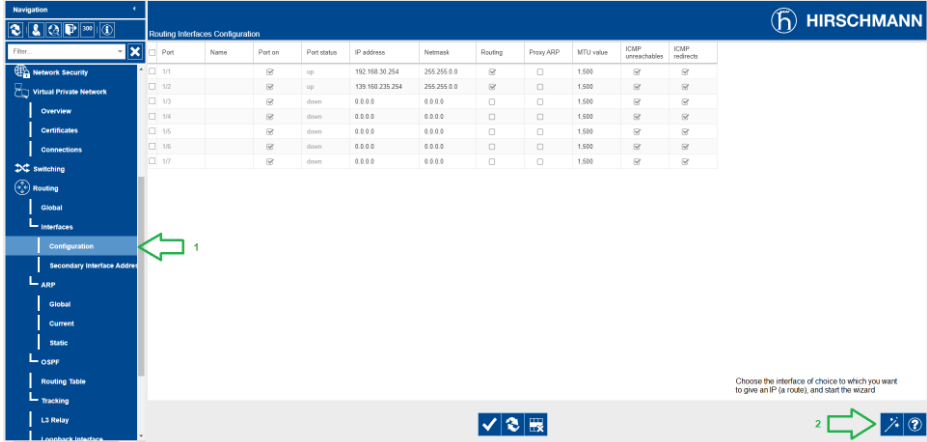
To configure the routes, proceed as follows:

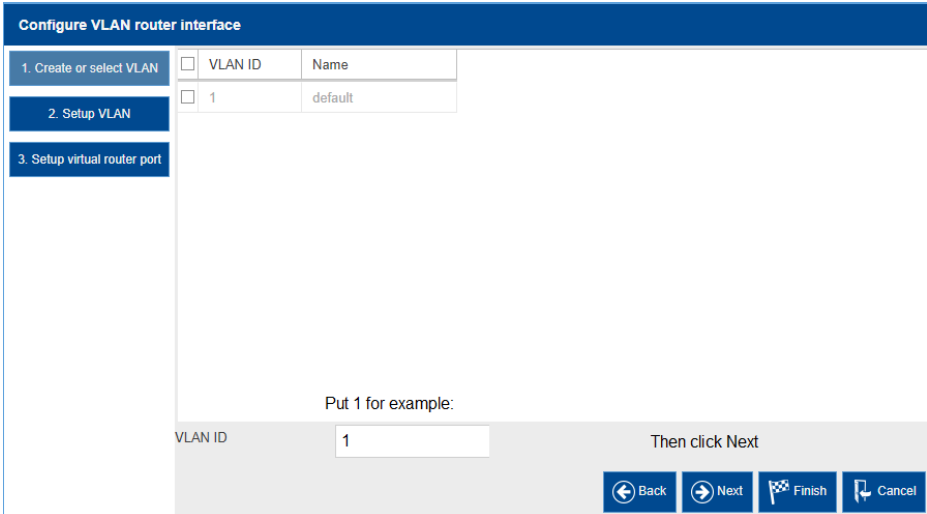
Step	Action
1	 <p>1. On the Navigation left pane open Routing > Interfaces > Configuration webpage. Choose the Ethernet interface you want to configure.</p> <p>2. Click the  icon to launch the Configure VLAN Router Interface window.</p>
2	 <p>Set an ID number to the VLAN you want to configure (1 in the example), then click Next.</p>

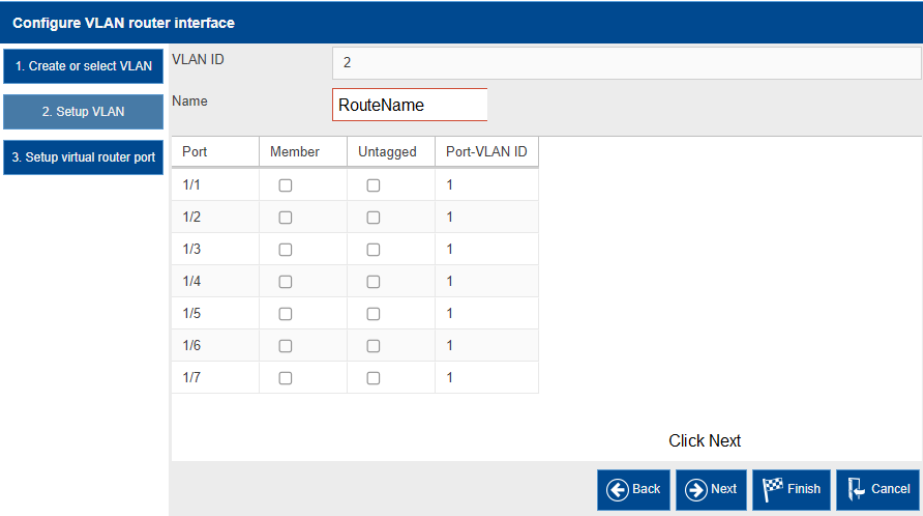
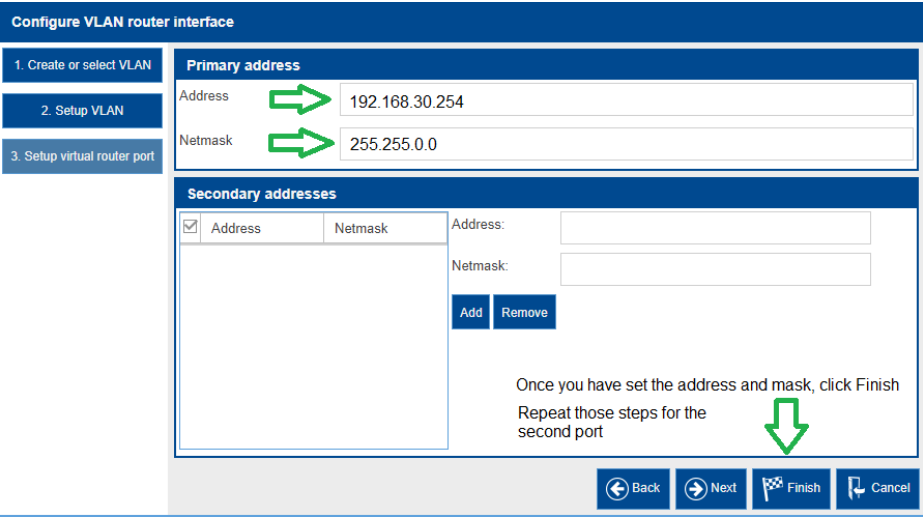
Step	Action
3	<p>Set a route name to the VLAN you want to configure (RouteName in the example), then click Next.</p> 
4	<p>Set the IP address of the Control Network and its mask, (192.168.30.254/16 in the example), then click Finish.</p> 
5	<p>Repeat the steps 1 to 4 for the Machine Network using the second Ethernet interface.</p>

In the following example we have set the control network gateway interface of the firewall to 192.168.30.254/16 on the physical port n°1 and machine network to 139.160.235.254/16 on the physical port n°2.

<input type="checkbox"/>	Port	Name	Port on	Port status	IP address	Netmask	Routing	Proxy ARP	MTU value	ICMP unreachable	ICMP redirects
<input type="checkbox"/>	1/1		<input checked="" type="checkbox"/>	up	192.168.30.254	255.255.0.0	<input checked="" type="checkbox"/>	<input type="checkbox"/>	1,500	<input checked="" type="checkbox"/>	<input checked="" type="checkbox"/>
<input type="checkbox"/>	1/2		<input checked="" type="checkbox"/>	up	139.160.235.254	255.255.0.0	<input checked="" type="checkbox"/>	<input type="checkbox"/>	1,500	<input checked="" type="checkbox"/>	<input checked="" type="checkbox"/>
<input type="checkbox"/>	1/3		<input checked="" type="checkbox"/>	down	0.0.0.0	0.0.0.0	<input type="checkbox"/>	<input type="checkbox"/>	1,500	<input checked="" type="checkbox"/>	<input checked="" type="checkbox"/>
<input type="checkbox"/>	1/4		<input checked="" type="checkbox"/>	down	0.0.0.0	0.0.0.0	<input type="checkbox"/>	<input type="checkbox"/>	1,500	<input checked="" type="checkbox"/>	<input checked="" type="checkbox"/>
<input type="checkbox"/>	1/5		<input checked="" type="checkbox"/>	down	0.0.0.0	0.0.0.0	<input type="checkbox"/>	<input type="checkbox"/>	1,500	<input checked="" type="checkbox"/>	<input checked="" type="checkbox"/>
<input type="checkbox"/>	1/6		<input checked="" type="checkbox"/>	down	0.0.0.0	0.0.0.0	<input type="checkbox"/>	<input type="checkbox"/>	1,500	<input checked="" type="checkbox"/>	<input checked="" type="checkbox"/>
<input type="checkbox"/>	1/7		<input checked="" type="checkbox"/>	down	0.0.0.0	0.0.0.0	<input type="checkbox"/>	<input type="checkbox"/>	1,500	<input checked="" type="checkbox"/>	<input checked="" type="checkbox"/>

Configuring the VPN in the Firewall

To configure the VPN, proceed as follows:

Step	Action
1	On the left pane of the web page, click on Virtual Private Network > Connections menu. Click the  icon.
2	Choose an index number and a name then click Next .
3	Choose a password (PSK) then click Next .

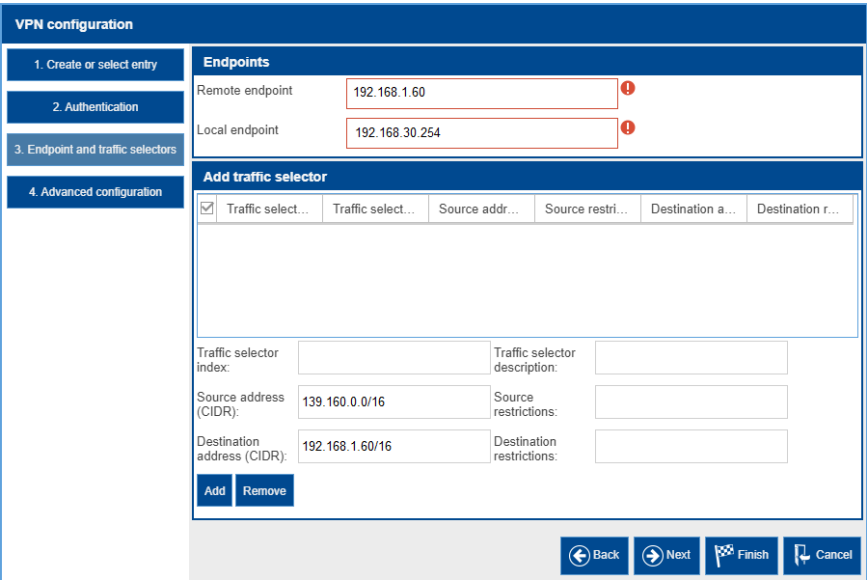
Step	Action
4	<p>Fill up the IP addresses and masks according to your network.</p> <ul style="list-style-type: none"> • Remote endpoint: The computer connecting to the firewall via VPN. • Local endpoint: The gateway configured in the Routes. • Source address (CIDR): The protected machine network accessible only once connected via VPN. • Destination address (CIDR): The computer connecting to the firewall via VPN.  <p>The screenshot shows a 'VPN configuration' wizard with four steps: 1. Create or select entry, 2. Authentication, 3. Endpoint and traffic selectors, and 4. Advanced configuration. In step 3, the 'Endpoints' section has 'Remote endpoint' set to 192.168.1.60 and 'Local endpoint' set to 192.168.30.254, both with red error icons. The 'Add traffic selector' section has a table with columns: Traffic select..., Traffic select..., Source addr..., Source restri..., Destination a..., and Destination r... Below this table are fields for 'Traffic selector index', 'Traffic selector description', 'Source address (CIDR): 139.160.0.0/16', 'Source restrictions', 'Destination address (CIDR): 192.168.1.60/16', and 'Destination restrictions'. There are 'Add' and 'Remove' buttons. At the bottom right are 'Back', 'Next', 'Finish', and 'Cancel' buttons.</p> <p>Click Next.</p>
5	<p>Set a margin time. The default value is 150.</p> <p>Set IKE Version to ikev2 then click Finish.</p>

Configuring the VPN Client

NOTE: In our example we use the VPN client solution provided by TheGreenBow. To configure the VPN client, proceed as follows:

Step	Action
1	Download and install the VPN client software.
2	On the left pane of the VPN Client window, right click VPN Configuration and choose Wizard .
3	Choose IKEv2 Tunnel and click Next .

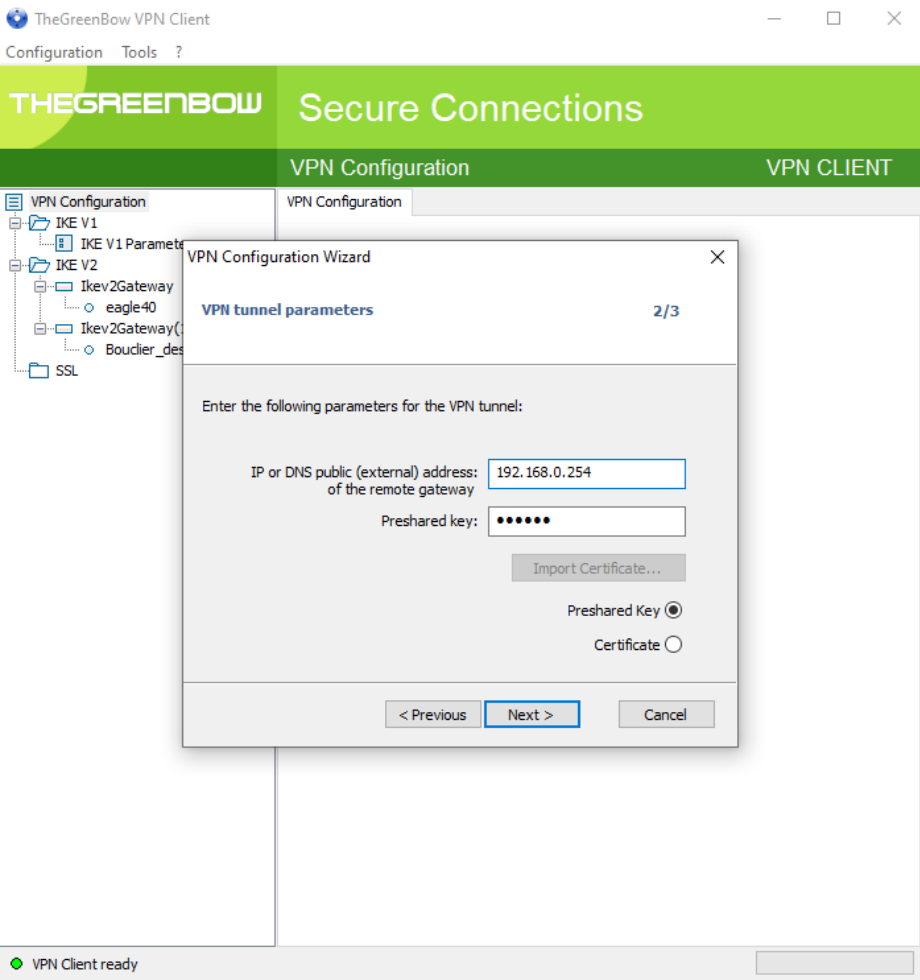
Step	Action
4	<p>Set the IP address of the firewall accessible via the Control Network interface (192.168.0.254 in the example).</p> <p>Enter the PSK previously selected.</p>  <p>Click Next, then click Finish.</p>
5	<p>On the left pane of the VPN Client window, right click on the Ikev2 tunnel just created and rename it.</p>
6	<p>Right click on the just renamed Ikev2 tunnel and select Open Tunnel.</p> <p>A notification confirms that the secure connection has been established.</p>

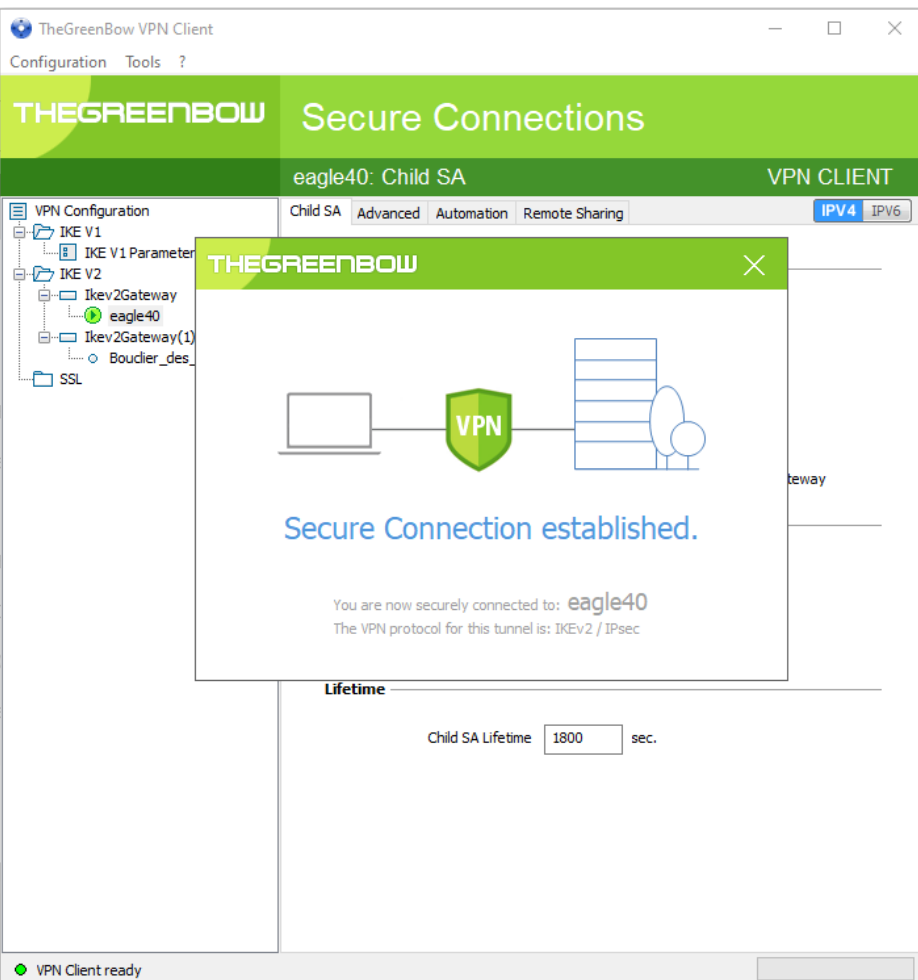
Step	Action
	 <p>The screenshot displays the 'TheGreenBow VPN Client' application window. The title bar reads 'TheGreenBow VPN Client' with standard window controls. Below the title bar is a menu bar with 'Configuration' and 'Tools ?'. The main interface has a green header with 'THEGREENBOW' and 'Secure Connections'. A sub-header indicates the current connection: 'eagle40: Child SA' and 'VPN CLIENT'. On the left, a tree view shows the configuration structure: 'VPN Configuration' (expanded) containing 'IKE V1' (with 'IKE V1 Parameter' selected), 'IKE V2' (with 'Ikev2Gateway' and 'eagle40' selected), 'Ikev2Gateway(1)', and 'Boudlier_des'. Below the tree, tabs for 'Child SA', 'Advanced', 'Automation', and 'Remote Sharing' are visible, along with 'IPV4' and 'IPV6' options. A large central dialog box with a green header 'THEGREENBOW' and a close button 'X' displays a diagram of a laptop connected to a server via a 'VPN' shield. The text reads: 'Secure Connection established.' followed by 'You are now securely connected to: eagle40' and 'The VPN protocol for this tunnel is: IKEv2 / IPsec'. Below this, a 'Lifetime' section shows 'Child SA Lifetime' set to '1800' seconds. At the bottom left, a green status indicator says 'VPN Client ready'.</p>

Glossary

802.1Q:

The IEEE protocol designator for Virtual Local Area Network (VLAN). This standard provides VLAN identification and quality of service (QoS) levels.

A**adapter:**

An adapter is the target of real-time I/O data connection requests from scanners. It cannot send or receive real-time I/O data unless it is configured to do so by a scanner, and it does not store or originate the data communications parameters necessary to establish the connection. An adapter accepts explicit message requests (connected and unconnected) from other devices.

advanced mode:

In Control Expert, advanced mode is a selection that displays expert-level configuration properties that help define Ethernet connections. Because these properties should be edited only by people with a good understanding of EtherNet/IP communication protocols, they can be hidden or displayed, depending upon the qualifications of the specific user.

applicative time stamping:

Use the applicative time stamping solution to access time stamp event buffers with a SCADA system that does not support the OPC DA interface. In this case, function blocks in the Control Expert application read events in the buffer and formats them to be sent to the SCADA system.

architecture:

Architecture describes a framework for the specification of a network that is constructed of these components:

- physical components and their functional organization and configuration
- operational principles and procedures
- data formats used in its operation

ARRAY:

An **ARRAY** is a table containing elements of a single type. This is the syntax: `ARRAY [<limits>] OF <Type>`

Example: `ARRAY [1..2] OF BOOL` is a one-dimensional table with two elements of type `BOOL`.

`ARRAY [1..10, 1..20] OF INT` is a two-dimensional table with 10x20 elements of type `INT`.

ART:

(*application response time*) The time a controller application takes to react to a given input. ART is measured from the time a physical signal in the controller turns on and triggers a write command until the remote output turns on to signify that the data has been received.

AUX:

An (AUX) task is an optional, periodic processor task that is run through its programming software. The AUX task is used to execute a part of the application requiring a low priority. This task is executed only if the MAST and FAST tasks have nothing to execute. The AUX task has two sections:

- **IN:** Inputs are copied to the IN section before execution of the AUX task.
- **OUT:** Outputs are copied to the OUT section after execution of the AUX task.

B**BCD:**

(*binary-coded decimal*) Binary encoding of decimal numbers.

BOOL:

(*boolean type*) This is the basic data type in computing. A `BOOL` variable can have either of these values: 0 (`FALSE`) or 1 (`TRUE`).

A bit extracted from a word is of type `BOOL`, for example: `%MW10.4`.

BOOTP:

(*bootstrap protocol*) A UDP network protocol that can be used by a network client to automatically obtain an IP address from a server. The client identifies itself to the server using its MAC address. The server, which maintains a pre-configured table of client device MAC addresses and associated IP addresses, sends the client its defined IP address. The BOOTP service utilizes UDP ports 67 and 68.

broadcast:

A message sent to all devices in a broadcast domain.

C**CCOTF:**

(change configuration on the fly) A feature of Control Expert that allows a module hardware change in the system configuration while the system is operating. This change does not impact active operations.

CIP™:

(common industrial protocol) A comprehensive suite of messages and services for the collection of manufacturing automation applications (control, safety, synchronization, motion, configuration and information). CIP allows users to integrate these manufacturing applications with enterprise-level Ethernet networks and the internet. CIP is the core protocol of EtherNet/IP.

class 1 connection:

A CIP transport class 1 connection used for I/O data transmission via implicit messaging between EtherNet/IP devices.

class 3 connection:

A CIP transport class 3 connection used for explicit messaging between EtherNet/IP devices.

connected messaging:

In EtherNet/IP, connected messaging uses a CIP connection for communication. A connected message is a logical relationship between two or more application objects on different nodes. The connection establishes a virtual circuit in advance for a particular purpose, such as frequent explicit messages or real-time I/O data transfers.

connection originator:

The EtherNet/IP network node that initiates a connection request for I/O data transfer or explicit messaging.

connection:

A virtual circuit between two or more network devices, created prior to the transmission of data. After a connection is established, a series of data is transmitted over the same communication path, without the need to include routing information, including source and destination address, with each piece of data.

connectionless:

Describes communication between two network devices, whereby data is sent without prior arrangement between the two devices. Each piece of transmitted data also includes routing information, including source and destination address.

control network:

An Ethernet-based network containing PACs, SCADA systems, an NTP server, PCs, AMS, switches, etc. Two kinds of topologies are supported:

- flat: All modules and devices in this network belong to same subnet.
- 2 levels: The network is split into an operation network and an inter-controller network. These two networks can be physically independent, but are generally linked by a routing device.

CPU:

(*central processing unit*) The CPU, also known as the processor or controller, is the brain of an industrial manufacturing process. It automates a process as opposed to relay control systems. CPUs are computers suited to survive the harsh conditions of an industrial environment.

D

DDT:

(*derived data type*) A derived data type is a set of elements with the same type (`ARRAY`) or with different types (structure).

determinism:

For a defined application and architecture, you can predict that the delay between an event (change of value of an input) and the corresponding change of a controller output is a finite time t , smaller than the deadline required by your process.

Device DDT (DDDT):

A Device DDT is a DDT predefined by the manufacturer and not modifiable by user. It contains the I/O language elements of an I/O module.

device network:

An Ethernet-based network within a remote I/O network that contains both remote I/O and distributed I/O devices. Devices connected on this network follow specific rules to allow remote I/O determinism.

device network:

An Ethernet-based network within an RIO network that contains both RIO and distributed equipment. Devices connected on this network follow specific rules to allow RIO determinism.

DFB:

(*derived function block*) DFB types are function blocks that can be defined by the user in ST, IL, LD or FBD language.

Using these DFB types in an application makes it possible to:

- simplify the design and entry of the program
- make the program easier to read
- make it easier to debug
- reduce the amount of code generated

DHCP:

(*dynamic host configuration protocol*) An extension of the BOOTP communications protocol that provides for the automatic assignment of IP addressing settings, including IP address, subnet mask, gateway IP address, and DNS server names. DHCP does not require the maintenance of a table identifying each network device. The client identifies itself to the DHCP server using either its MAC address, or a uniquely assigned device identifier. The DHCP service utilizes UDP ports 67 and 68.

DIO cloud:

A group of distributed equipment that is not required to support RSTP. DIO clouds require only a single (non-ring) copper wire connection. They can be connected to some of the copper ports on DRSS, or they can be connected directly to the controller or Ethernet communications modules in the *local rack*. DIO clouds **cannot** be connected to *sub-rings*.

DIO network:

A network containing distributed equipment, in which I/O scanning is performed by a controller with DIO scanner service on the local rack. DIO network traffic is delivered after RIO traffic, which takes priority in an RIO network.

DIO:

(*distributed I/O*) Also known as distributed equipment. DRSS use DIO ports to connect distributed equipment.

distributed equipment:

Any Ethernet device (Schneider Electric device, PC, servers, or third-party devices) that supports exchange with a controller or other Ethernet I/O scanner service.

DNS:

(*domain name server/service*) A service that translates an alpha-numeric domain name into an IP address, the unique identifier of a device on the network.

domain name:

An alpha-numeric string that identifies a device on the internet, and which appears as the primary component of a web site's uniform resource locator (URL). For example, the domain name *schneider-electric.com* is the primary component of the URL *www.se.com*.

Each domain name is assigned as part of the domain name system, and is associated with an IP address.

Also called a host name.

DRS:

(*dual-ring switch*) A ConneXium extended managed switch that has been configured to operate on an Ethernet network. Predefined configuration files are provided by Schneider Electric to be downloaded to a DRS to support the special features of the main ring / sub-ring architecture.

DSCP:

(*differentiated service code points*) This 6-bit field is in the header of an IP packet to classify and prioritize traffic.

DST:

(*daylight saving time*) DST is also called *summer time* and is a practice consisting of adjusting forward the clock near the start of spring and adjusting it backward near the start of autumn.

DT:

(*date and time*) The DT type, encoded in BCD in a 64-bit format, contains this information:

- the year encoded in a 16-bit field
- the month encoded in an 8-bit field
- the day encoded in an 8-bit field
- the time encoded in an 8-bit field
- the minutes encoded in an 8-bit field
- the seconds encoded in an 8-bit field

NOTE: The eight least significant bits are not used.

The DT type is entered in this format:

DT#<Year>-<Month>-<Day>-<Hour>:<Minutes>:<Seconds>

This table shows the upper/lower limits of each field:

Field	Limits	Comment
Year	[1990,2099]	Year
Month	[01,12]	The leading 0 is displayed; it can be omitted during data entry.
Day	[01,31]	For months 01/03/05/07/08/10/12
	[01,30]	For months 04/06/09/11
	[01,29]	For month 02 (leap years)
	[01,28]	For month 02 (non-leap years)
Hour	[00,23]	The leading 0 is displayed; it can be omitted during data entry.
Minute	[00,59]	The leading 0 is displayed; it can be omitted during data entry.
Second	[00,59]	The leading 0 is displayed; it can be omitted during data entry.

DTM:

(*device type manager*) A DTM is a device driver running on the host PC. It provides a unified structure for accessing device parameters, configuring and operating the devices, and troubleshooting devices. DTMs can range from a simple graphical user interface (GUI) for setting device parameters to a highly sophisticated application capable of performing complex real-time calculations for diagnosis and maintenance purposes. In the context of a DTM, a device can be a communications module or a remote device on the network.

See FDT.

E

EDS:

(*electronic data sheet*) EDS are simple text files that describe the configuration capabilities of a device. EDS files are generated and maintained by the manufacturer of the device.

EFB:

(*elementary function block*) This is a block used in a program which performs a predefined logical function.

EFBs have states and internal parameters. Even if the inputs are identical, the output values may differ. For example, a counter has an output indicating that the preselection value has been reached. This output is set to 1 when the value is equal to the preselection value.

EF:

(*elementary function*) This is a block used in a program which performs a predefined logical function.

A function does not have any information on the internal state. Several calls to the same function using the same input parameters will return the same output values. You will find information on the graphic form of the function call in the [*functional block (instance)*]. Unlike a call to a function block, function calls include only an output which is not named and whose name is identical to that of the function. In FBD, each call is indicated by a unique [number] via the graphic block. This number is managed automatically and cannot be modified.

Position and configure these functions in your program to execute your application.

You can also develop other functions using the SDKC development kit.

EIO network:

(*Ethernet I/O*) An Ethernet-based network that contains three types of devices:

- local rack
- X80 remote drop (using a BM•CRA312•0 adapter module), or a BMENOS0300 network option switch module
- ConneXium extended dual-ring switch (DRS)

NOTE: Distributed equipment may also participate in an Ethernet I/O network via connection to DRSs or the service port of X80 remote modules.

EN:

EN stands for **EN**able; it is an optional block input. When the EN input is enabled, an ENO output is set automatically.

If EN = 0, the block is not enabled; its internal program is not executed, and ENO is set to 0.

If EN = 1, the block's internal program is run and ENO is set to 1. If a runtime error is detected, ENO is set to 0.

If the EN input is not connected, it is set automatically to 1.

ENO:

ENO stands for **Er**rор **NO**tification; this is the output associated with the optional input EN.

If ENO is set to 0 (either because EN = 0 or if a runtime error is detected):

- The status of the function block outputs remains the same as it was during the previous scanning cycle that executed correctly.
- The output(s) of the function, as well as the procedures, are set to 0.

Ethernet DIO scanner service:

This embedded DIO scanner service of M580 controllers manages distributed equipment on an M580 device network.

Ethernet I/O scanner service:

This embedded Ethernet I/O scanner service of M580 controllers manages distributed equipment **and** RIO drops on an M580 device network.

EtherNet/IP™:

A network communication protocol for industrial automation applications that combines the standard internet transmission protocols of TCP/IP and UDP with the application layer common industrial protocol (CIP) to support both high speed data exchange and industrial control. EtherNet/IP employs electronic data sheets (EDS) to classify each network device and its functionality.

Ethernet:

A 10 Mb/s, 100 Mb/s, or 1 Gb/s, CSMA/CD, frame-based LAN that can run over copper twisted pair or fiber optic cable, or wireless. The IEEE standard 802.3 defines the rules for configuring a wired Ethernet network; the IEEE standard 802.11 defines the rules for configuring a wireless Ethernet network. Common forms include 10BASE-T, 100BASE-TX, and 1000BASE-T, which can utilize category 5e copper twisted pair cables and RJ45 modular connectors.

explicit messaging client:

(explicit messaging client class) The device class defined by the ODVA for EtherNet/IP nodes that only support explicit messaging as a client. HMI and SCADA systems are common examples of this device class.

explicit messaging:

TCP/IP-based messaging for Modbus TCP and EtherNet/IP. It is used for point-to-point, client/server messages that include both data, typically unscheduled information between a client and a server, and routing information. In EtherNet/IP, explicit messaging is considered class 3 type messaging, and can be connection-based or connectionless.

F

FAST:

A FAST task is an optional, periodic processor task that identifies high priority, multiple scan requests, which is run through its programming software. A FAST task can schedule selected I/O modules to have their logic solved more than once per scan. The FAST task has two sections:

- IN: Inputs are copied to the IN section before execution of the FAST task.
- OUT: Outputs are copied to the OUT section after execution of the FAST task.

FBD:

(function block diagram) An IEC 61131-3 graphical programming language that works like a flowchart. By adding simple logical blocks (AND, OR, etc.), each function or function block in the program is represented in this graphical format. For each block, the inputs are on the left and the outputs on the right. Block outputs can be linked to inputs of other blocks to create complex expressions.

FDR:

(fast device replacement) A service that uses configuration software to replace an inoperable product.

FDT:

(field device tool) The technology that harmonizes communication between field devices and the system host.

FTP:

(file transfer protocol) A protocol that copies a file from one host to another over a TCP/IP-based network, such as the internet. FTP uses a client-server architecture as well as separate control and data connections between the client and server.

full duplex:

The ability of two networked devices to independently and simultaneously communicate with each other in both directions.

function block diagram:

See FBD.

G**gateway:**

A gateway device interconnects two different networks, sometimes through different network protocols. When it connects networks based on different protocols, a gateway converts a datagram from one protocol stack into the other. When used to connect two IP-based networks, a gateway (also called a router) has two separate IP addresses, one on each network.

GPS:

(global positioning system) The GPS standard consists of a space-based positioning, navigation, and timing signals delivered worldwide for civil and military use. Standard positioning service performance depends on satellite broadcast signal parameters, GPS constellation design, the number of satellites in sight, and various environmental parameters.

H**harsh environment:**

Resistance to hydrocarbons, industrial oils, detergents and solder chips. Relative humidity up to 100%, saline atmosphere, significant temperature variations, operating temperature between -10°C and + 70°C, or in mobile installations. For hardened (H) devices, the relative humidity is up to 95% and the operating temperature is between -25°C and + 70°C.

HART:

(highway addressable remote transducer) A bi-directional communication protocol for sending and receiving digital information across analog wires between a control or monitoring system and smart devices.

HART is the global standard for providing data access between host systems and intelligent field instruments. A host can be any software application from a technician's hand-held device or laptop to a plant's process control, asset management, or other system using any control system.

high-capacity daisy chain loop:

Often referred to as HCDL, a high-capacity daisy chain loop uses dual-ring switches (DRSs) to connect device sub-rings (containing RIO drops or distributed equipment) and/or DIO clouds to the Ethernet RIO network.

HMI:

(human machine interface) System that allows interaction between a human and a machine.

Hot Standby:

A Hot Standby system uses a primary PAC (PLC) and a standby PAC. The two PAC racks have identical hardware and software configurations. The standby PAC monitors the current system status of the primary PAC. If the primary PAC becomes inoperable, high-availability control is maintained when the standby PAC takes control of the system.

HTTP:

(hypertext transfer protocol) A networking protocol for distributed and collaborative information systems. HTTP is the basis of data communication for the web.

I

%I:

According to the CEI standard, %I indicates a language object of type discrete IN.

IEC 61131-3:

International standard: programmable logic controllers

Part 3: programming languages

IGMP:

(internet group management protocol) This internet standard for multicasting allows a host to subscribe to a particular multicast group.

IL:

(instruction list) An IEC 61131-3 programming language that contains a series of basic instructions. It is very close to assembly language used to program processors. Each instruction is made up of an instruction code and an operand.

implicit messaging:

UDP/IP-based class 1 connected messaging for EtherNet/IP. Implicit messaging maintains an open connection for the scheduled transfer of control data between a producer and consumer. Because an open connection is maintained, each message contains primarily data, without the overhead of object information, plus a connection identifier.

inter-controller network:

An Ethernet-based network that is part of the control network, and provides data exchange between controllers and engineering tools (programming, asset management system (AMS)).

I/O scanner:

An Ethernet service that continuously polls I/O modules to collect data, status, event, and diagnostics information. This process monitors inputs and controls outputs. This service supports both RIO and DIO logic scanning.

INT:

(*IN*Teger) (encoded in 16 bits) The upper/lower limits are as follows: $-(2 \text{ to the power of } 15)$ to $(2 \text{ to the power of } 15) - 1$.

Example: -32768, 32767, 2#1111110001001001, 16#9FA4.

IODDT:

(*input/output derived data type*) A structured data type representing a module, or a channel of a CPU. Each application expert module possesses its own IODDTs.

IP address:

The 32-bit identifier, consisting of both a network address and a host address assigned to a device connected to a TCP/IP network.

IPsec:

(*internet protocol security*) An open set of protocol standards that make IP communication sessions private and encrypted for traffic between modules using IPsec, developed by the internet engineering task force (IETF). The IPsec authentication and encryption algorithms require user-defined cryptographic keys that process each communications packet in an IPsec session.

isolated DIO network:

An Ethernet-based network containing distributed equipment that does not participate in an RIO network.

%IW:

According to the CEI standard, %IW indicates a language object of type analog IN.

L

LD:

(*ladder diagram*) An IEC 61131-3 programming language that represents instructions to be executed as graphical diagrams very similar to electrical diagrams (contacts, coils, etc.).

literal value of an integer:

A literal value of an integer is used to enter integer values in the decimal system. Values may be preceded by the "+" and "-" signs. Underscore signs (_) separating numbers are not significant.

Example:

-12, 0, 123_456, +986

local rack:

An M580 rack containing the CPU and a power supply. A local rack consists of one or two racks: the main rack and the extended rack, which belongs to the same family as the main rack. The extended rack is optional.

local slave:

The functionality offered by Schneider Electric EtherNet/IP communication modules that allows a scanner to take the role of an adapter. The local slave enables the module to publish data via implicit messaging connections. Local slave is typically used in peer-to-peer exchanges between PACs.

M

main ring:

The main ring of an Ethernet RIO network. The ring contains RIO modules and a local rack (containing a CPU with Ethernet I/O scanner service) and a power supply module.

%M:

According to the CEI standard, %M indicates a language object of type memory bit.

M580 Ethernet I/O device:

An Ethernet device that provides automatic network recovery and deterministic RIO performance. The time it takes to resolve an RIO logic scan can be calculated, and the system can recover quickly from a communication disruption. M580 Ethernet I/O devices include:

- local rack (including a CPU with Ethernet I/O scanner service)
- RIO drop (including an X80 adapter module)
- DRS switch with a predefined configuration

MAST:

A master (MAST) task is a deterministic processor task that is run through its programming software. The MAST task schedules the RIO module logic to be solved in every I/O scan. The MAST task has two sections:

- IN: Inputs are copied to the IN section before execution of the MAST task.
- OUT: Outputs are copied to the OUT section after execution of the MAST task.

MB/TCP:

(*Modbus over TCP protocol*) This is a Modbus variant used for communications over TCP/IP networks.

MIB:

(*management information base*) A virtual database used for managing the objects in a communications network. See SNMP.

Modbus:

Modbus is an application layer messaging protocol. Modbus provides client and server communications between devices connected on different types of buses or networks. Modbus offers many services specified by function codes.

multicast:

A special form of broadcast where copies of the packet are delivered to only a specified subset of network destinations. Implicit messaging typically uses multicast format for communications in an EtherNet/IP network.

%MW:

According to the CEI standard, %MW indicates a language object of type memory word.

N

network convergence:

Activity of re-configuring the network in situation of network loss to ensure system availability.

network time service:

Use this service to synchronize computer clocks over the Internet to record events (sequence events), synchronize events (trigger simultaneous events), or synchronize alarms and I/O (time stamp alarms).

network:

There are two meanings:

- In a ladder diagram:

A network is a set of interconnected graphic elements. The scope of a network is local, concerning the organizational unit (section) of the program containing the network.

- With expert communication modules:

A network is a set of stations that intercommunicate. The term *network* is also used to define a group interconnected graphic elements. This group then makes up part of a program that may comprise a group of networks.

NIM:

(*network interface module*) A NIM resides in the first position on an STB island (leftmost on the physical setup). The NIM provides the interface between the I/O modules and the fieldbus master. It is the only module on the island that is fieldbus-dependent — a different NIM is available for each fieldbus.

NTP:

(*network time protocol*) Protocol for synchronizing computer system clocks. The protocol uses a jitter buffer to resist the effects of variable latency.

O

O->T:

(*originator to target*) See originator and target.

ODVA:

(*Open DeviceNet Vendors Association*) The ODVA supports network technologies that are based on CIP.

OFS:

(*OPC Factory Server*) OFS enables real-time SCADA communications with the Control Expert family of PLCs. OFS utilizes the standard OPC data access protocol.

OPC DA:

(*OLE for Process Control Data Access*) The Data Access Specification is the most commonly implemented of the OPC standards that provide specifications for real-time data communications between clients and servers.

operation network:

An Ethernet-based network containing operator tools (SCADA, client PC, printers, batch tools, EMS, etc.). Controllers are connected directly or through routing of the inter-controller network. This network is part of the control network.

originator:

In EtherNet/IP, a device is considered the originator when it initiates a CIP connection for implicit or explicit messaging communications or when it initiates a message request for un-connected explicit messaging.

P**PAC:**

programmable automation controller. The PAC is the brain of an industrial manufacturing process. It automates a process as opposed to relay control systems. PACs are computers suited to survive the harsh conditions of an industrial environment.

port 502:

Port 502 of the TCP/IP stack is the well-known port that is reserved for Modbus TCP communications.

port mirroring:

In this mode, data traffic that is related to the source port on a network switch is copied to another destination port. This allows a connected management tool to monitor and analyze the traffic.

PTP:

(*precision time protocol*) Use this protocol to synchronize clocks throughout a computer network. On a local area network, PDP achieves clock accuracy in the sub-microsecond range, making it suitable for measurement and control systems.

Q

%Q:

According to the CEI standard, %Q indicates a language object of type discrete OUT.

QoS:

(quality of service) The practice of assigning different priorities to traffic types for the purpose of regulating data flow on the network. In an industrial network, QoS is used to provide a predictable level of network performance.

%QW:

According to the CEI standard, %QW indicates a language object of type analog OUT.

R

rack optimized connection:

Data from multiple I/O modules are consolidated in a single data packet to be presented to the scanner in an implicit message in an EtherNet/IP network.

ready device:

Ethernet ready device that provides additional services to the EtherNet/IP or Modbus module, such as: single parameter entry, bus editor declaration, system transfer, deterministic scanning capacity, alert message for modifications, and shared user rights between Control Expert and the device DTM.

RIO drop:

One of the three types of RIO modules in an Ethernet RIO network. An RIO drop is an M580 rack of I/O modules that are connected to an Ethernet RIO network and managed by an Ethernet RIO adapter module. A drop can be a single rack or a main rack with an extended rack.

RIO network:

An Ethernet-based network that contains 3 types of RIO devices: a local rack, an RIO drop, and a ConneXium extended dual-ring switch (DRS). Distributed equipment may also participate in an RIO network via connection to DRSs or BMENOS0300 network option switch modules.

RPI:

(requested packet interval) The time period between cyclic data transmissions requested by the scanner. EtherNet/IP devices publish data at the rate specified by the RPI assigned to them by the scanner, and they receive message requests from the scanner at each RPI.

RSTP:

(*rapid spanning tree protocol*) Allows a network design to include spare (redundant) links to provide automatic backup paths if an active link stops working, without the need for loops or manual enabling/disabling of backup links.

S**S908 RIO:**

A Quantum RIO system using coaxial cabling and terminators.

SCADA:

(*supervisory control and data acquisition*) SCADA systems are computer systems that control and monitor industrial, infrastructure, or facility-based processes (examples: transmitting electricity, transporting gas and oil in pipelines, and distributing water).

scanner class device:

A scanner class device is defined by the ODVA as an EtherNet/IP node capable of originating exchanges of I/O with other nodes in the network.

scanner:

A scanner acts as the originator of I/O connection requests for implicit messaging in EtherNet/IP, and message requests for Modbus TCP.

service port:

A dedicated Ethernet port on the M580 RIO modules. The port may support these major functions (depending on the module type):

- port mirroring: for diagnostic use
- access: for connecting HMI/Control Expert/ConneXview to the CPU
- extended: to extend the device network to another subnet
- disabled: disables the port, no traffic is forwarded in this mode

SFC:

(*sequential function chart*) An IEC 61131-3 programming language that is used to graphically represent in a structured manner the operation of a sequential CPU. This graphical description of the CPU's sequential behavior and of the various resulting situations is created using simple graphic symbols.

SFP:

(*small form-factor pluggable*). The SFP transceiver acts as an interface between a module and fiber optic cables.

simple daisy chain loop:

Often referred to as SDCL, a simple daisy chain loop contains RIO modules only (no distributed equipment). This topology consists of a local rack (containing a CPU with Ethernet I/O scanner service), and one or more RIO drops (each drop containing an RIO adapter module).

SMTP:

(simple mail transfer protocol) An email notification service that allows controller-based projects to report alarms or events. The controller monitors the system and can automatically create an email message alert with data, alarms, and/or events. Mail recipients can be either local or remote.

SNMP:

(simple network management protocol) Protocol used in network management systems to monitor network-attached devices. The protocol is part of the internet protocol suite (IP) as defined by the internet engineering task force (IETF), which consists of network management guidelines, including an application layer protocol, a database schema, and a set of data objects.

SNTP:

(simple network time protocol) See NTP.

SOE:

(sequence of events) SOE software helps users understand a chain of occurrences that can lead to unsafe process conditions and possible shutdowns. SOEs can be critical to help resolving or preventing such conditions.

ST:

(structured text) An IEC 61131-3 programming language that presents structured literal language and is a developed language similar to computer programming languages. It can be used to organize a series of instructions.

sub-ring:

An Ethernet-based network with a loop attached to the main ring, via a dual-ring switch (DRS) or BMENOS0300 network option switch module on the main ring. This network contains RIO or distributed equipment.

subnet mask:

The 32-bit value used to hide (or mask) the network portion of the IP address and thereby reveal the host address of a device on a network using the IP protocol.

%SW:

According to the CEI standard, %SW indicates a language object of type system word.

switch:

A multi-port device used to segment the network and limit the likelihood of collisions. Packets are filtered or forwarded based upon their source and destination addresses. Switches are capable of full-duplex operation and provide full network bandwidth to each port. A switch can have different input/output speeds (for example, 10, 100 or 1000Mbps). Switches are considered OSI layer 2 (data link layer) devices.

T**T->O:**

(*target to originator*) See target and originator.

target:

In EtherNet/IP, a device is considered the target when it is the recipient of a connection request for implicit or explicit messaging communications, or when it is the recipient of a message request for un-connected explicit messaging.

TCP/IP:

Also known as *internet protocol suite*, TCP/IP is a collection of protocols used to conduct transactions on a network. The suite takes its name from two commonly used protocols: transmission control protocol and internet protocol. TCP/IP is a connection-oriented protocol that is used by Modbus TCP and EtherNet/IP for explicit messaging.

TCP:

(*transmission control protocol*) A key protocol of the internet protocol suite that supports connection-oriented communications, by establishing the connection necessary to transmit an ordered sequence of data over the same communication path.

TFTP:

(*trivial file transfer protocol*) A simplified version of *file transfer protocol* (FTP), TFTP uses a client-server architecture to make connections between two devices. From a TFTP client, individual files can be uploaded to or downloaded from the server, using the user datagram protocol (UDP) for transporting data.

TIME_OF_DAY:

See TOD.

TOD:

(*time of day*) The TOD type, encoded in BCD in a 32-bit format, contains this information:

- the hour encoded in an 8-bit field
- the minutes encoded in an 8-bit field
- the seconds encoded in an 8-bit field

NOTE: The eight least significant bits are not used.

The TOD type is entered in this format: xxxxxxxx: **TOD#**<Hour>:<Minutes>:<Seconds>

This table shows the upper/lower limits of each field:

Field	Limits	Comment
Hour	[00,23]	The leading 0 is displayed; it can be omitted during data entry.
Minute	[00,59]	The leading 0 is displayed; it can be omitted during data entry.
Second	[00,59]	The leading 0 is displayed; it can be omitted during data entry.

Example: TOD#23:59:45.

trap:

A trap is an event directed by an SNMP agent that indicates one of these events:

- A change has occurred in the status of an agent.
- An unauthorized SNMP manager device has attempted to get data from (or change data on) an SNMP agent.

TR:

(*transparent ready*) Web-enabled power distribution equipment, including medium- and low-voltage switch gear, switchboards, panel boards, motor control centers, and unit substations. Transparent Ready equipment allows you to access metering and equipment status from any PC on the network, using a standard web browser.

U

UDP:

(*user datagram protocol*) A transport layer protocol that supports connectionless communications. Applications running on networked nodes can use UDP to send datagrams to one another. Unlike TCP, UDP does not include preliminary communication to establish data paths or provide data ordering and checking. However, by avoiding the overhead required to provide these features, UDP is faster than TCP. UDP may be the preferred protocol for time-sensitive applications, where dropped datagrams are preferable to delayed datagrams. UDP is the primary transport for implicit messaging in EtherNet/IP.

UMAS:

(*Unified Messaging Application Services*) UMAS is a proprietary system protocol that manages communications between Control Expert and a controller.

UTC:

(*coordinated universal time*) Primary time standard used to regulate clocks and time worldwide (close to former GMT time standard).

V**variable:**

Memory entity of type `BOOL`, `WORD`, `DWORD`, etc., whose contents can be modified by the program currently running.

VLAN:

(*virtual local area network*) A local area network (LAN) that extends beyond a single LAN to a group of LAN segments. A VLAN is a logical entity that is created and configured uniquely using applicable software.

Index

A

- access
 - USB 19
- access control
 - cybersecurity 114
 - security 31
- access control policy
 - CSPN 46
- accounts
 - cybersecurity 89
- ACL
 - security 31
- administrative interface
 - CSPN 46
- architecture 18
- assets
 - critical, M580 CSPN controller 45
 - critical, M580 CSPN environment 45
- audit trail
 - security 48
- authentication
 - cybersecurity 114
- authorization
 - security 93
- authorizations
 - cybersecurity 114

C

- certification
 - CSPN 40
- communication services
 - disable 30
- communication, secure
 - CSPN 46
- Control Expert
 - password 92
- Control Expert Security Editor 43
- controller execution mode
 - CSPN 46
- controller memory
 - CSPN 46
- critical assets

- environment, M580 CSPN 45
- PAC, M580 CSPN 45
- CSPN 40
 - critical assets, controller 45
 - critical assets, environment 45
 - M580 cybersecurity parameters 44
 - M580 operating modes 44
 - M580, access control policy 46
 - M580, denial of service 46
 - M580, encrypted authentication on
 - administrative interface 46
 - M580, encrypted communications 46
 - M580, execution mode alteration 46
 - M580, firmware alteration 46
 - M580, firmware signature 46
 - M580, flows alteration 46
 - M580, integrity and authenticity of controller
 - memory 46
 - M580, integrity of the controller execution
 - mode 46
 - M580, malformed input management 46
 - M580, memory program alteration 46
 - M580, secure storage of secrets 46
- cybersecurity 16
 - access control 114
 - accounts 89
 - authentication 114
 - authorizations 114
 - CSPN 40
 - CSPN, M580 40
 - CSPN, M580 operating modes 44
 - disable unused services 114
 - event logging 114
 - firmware 114
 - FTP 91
 - guidelines 16
 - HTTP 90
 - integrity checks 114
 - LANMAN / NTLM 26
 - literature 16
 - local area connection 27
 - M340 120
 - M580 121
 - M580 Control Expert Security Editor 43
 - M580 CSPN parameters 44
 - network interface cards 27
 - notifications 16
 - passwords 89

Premium/Atrium.....	125	FTP	
Quantum.....	121	cybersecurity.....	91
remote desktop.....	26	H	
secured communication	114	hardening	
services	114	PC.....	22
SNMP.....	92	HTTP	
vulnerability.....	16	cybersecurity.....	90
X80.....	123		
D		I	
denial of service		input management, malformed	
CSPN	46	CSPN	46
disable		integrity check	
communication services	30	security	97
disable unused services		integrity checks	
cybersecurity.....	114	cybersecurity.....	114
E		interface, administrative	
event log messages	62	CSPN	46
BMENOR2200H.....	74	L	
BMENUA0100.....	74	LAN	
Control Expert	56	cybersecurity.....	27
M580 controller (firmware earlier than		LANMAN / NTLM	
V4.10).....	74	cybersecurity.....	26
M580 controller (for firmware V4.10 and any		literature	
subsequent supporting version(s).....	62	cybersecurity.....	16
event logging		logging	
cybersecurity.....	114	security	48
execution mode alteration		M	
CSPN	46	memory	
execution mode, controller		protect	94
CSPN	46	memory program alteration	
F		CSPN	46
firmware		memory protection	
cybersecurity.....	114	security	97
security	114	memory, controller	
firmware alteration		CSPN	46
CSPN	46	M340	
firmware signature		cybersecurity.....	120
CSPN	46	M580	
flows alteration			
CSPN	46		

cybersecurity 121

N

network interface cards
 cybersecurity 27

notifications
 cybersecurity 16

O

Operate
 M580 Control Expert Security Editor
 profile 43

operating modes
 CSPN, M580 44

P

password
 Control Expert 92

passwords
 cybersecurity 89

PC
 hardening 22

Premium/Atrium
 cybersecurity 125

profile
 M580 Control Expert Security Editor 43

Program
 M580 Control Expert Security Editor
 profile 43

protect
 memory 94

protection
 section 94

Q

Quantum
 cybersecurity 121

R

ReadOnly

M580 Control Expert Security Editor
 profile 43

remote desktop
 cybersecurity 26

run/stop
 security 95

S

section
 protection 94

secure communication
 CSPN 46

secured communication
 cybersecurity 114

security
 access control 31
 ACL 31
 audit trail 48
 authorization 93
 CSPN 40
 CSPN, M580 operating modes 44
 firmware 114
 integrity check 97
 logging 48
 M580 Control Expert Security Editor 43
 M580 CSPN parameters 44
 memory protection 97
 run/stop 95
 services 114
 Syslog 48

services
 cybersecurity 114
 security 114

signature, firmware
 CSPN 46

SNMP
 cybersecurity 92

storage of secrets
 CSPN 46

Syslog
 BMENOR2200H 74
 BMENUA0100 74
 Control Expert 56
 M580 controller (firmware earlier than
 V4.10) 74

M580 controller (firmware V4.10 and any subsequent supporting version(s)).....	62
security	48

U

USB	
access	19
user profiles	
security, M580 Control Expert Security Editor	43

V

vulnerability	
cybersecurity	16

X

X80	
cybersecurity	123

Schneider Electric
35 rue Joseph Monier
92500 Rueil Malmaison
France

+ 33 (0) 1 41 29 70 00

www.se.com

As standards, specifications, and design change from time to time, please ask for confirmation of the information given in this publication.

© 2023 Schneider Electric. All rights reserved.

EIO0000001999.11