

PacDrive Logic Motion Controller

LMC Eco

Hardware Guide

Original instructions

EIO0000001501.10
04/2025

Legal Information

The information provided in this document contains general descriptions, technical characteristics and/or recommendations related to products/solutions.

This document is not intended as a substitute for a detailed study or operational and site-specific development or schematic plan. It is not to be used for determining suitability or reliability of the products/solutions for specific user applications. It is the duty of any such user to perform or have any professional expert of its choice (integrator, specifier or the like) perform the appropriate and comprehensive risk analysis, evaluation and testing of the products/solutions with respect to the relevant specific application or use thereof.

The Schneider Electric brand and any trademarks of Schneider Electric SE and its subsidiaries referred to in this document are the property of Schneider Electric SE or its subsidiaries. All other brands may be trademarks of their respective owner.

This document and its content are protected under applicable copyright laws and provided for informative use only. No part of this document may be reproduced or transmitted in any form or by any means (electronic, mechanical, photocopying, recording, or otherwise), for any purpose, without the prior written permission of Schneider Electric.

Schneider Electric does not grant any right or license for commercial use of the document or its content, except for a non-exclusive and personal license to consult it on an "as is" basis.

Schneider Electric reserves the right to make changes or updates with respect to or in the content of this document or the format thereof, at any time without notice.

To the extent permitted by applicable law, no responsibility or liability is assumed by Schneider Electric and its subsidiaries for any errors or omissions in the informational content of this document, as well as any non-intended use or misuse of the content thereof.

Table of Contents

Safety Information	5
QUALIFICATION OF PERSONNEL	5
INTENDED USE	6
About the Document	7
Specific Safety Information	10
Product Related Information	10
Intended Use	15
System Overview	17
Overview	17
Logic Motion Controller	17
Lexium 62 Drive System	18
Lexium 52	21
Lexium 62 Servo Drive	21
SH3 Servo Motor	22
TM5 System	23
Type Code	24
Nameplate Descriptions	24
Engineering	26
Electromagnetic Compatibility, EMC	26
Control Cabinet Planning	28
Degree of Protection (IP)	28
Mechanical and Climatic Environmental Conditions in the Control Cabinet	29
Using Cooling Units	29
Information about Wiring	30
General Information about Wiring	30
Cable Characteristics	31
Configuring and Coding the Cables	31
ESD Protection Measures	31
Installation and Maintenance	33
Commissioning	33
Prerequisites for Commissioning	33
Preparing Commissioning	33
Preparing the Control Cabinet	34
Mechanical Mounting	36
Wiring of the Controller	37
Completion of Commissioning	38
Performing the Function Test	39
Maintenance, Repair, Cleaning, Replacement Equipment Inventory	39
Prerequisites for Maintenance, Repair, and Cleaning	39
Repair	40
Cleaning	40
Battery, Real-Time Clock	40
Replacement Equipment Inventory	41
Replacing Components and Cables	41
Prerequisites for Replacing Components and Cables	41
Device Replacement	43

Fast Device Replacement (FDR) - Introduction	44
Fast Device Replacement - Usage.....	44
Fast Device Replacement - Controller Display	46
Fast Device Replacement - Application.....	47
Cable Replacement.....	51
Indicators and Control Elements	53
Indicators of the Controller	53
Menu Navigation.....	56
Memory Card Slot (SD Card)	59
USB Connection	62
Integrated Communication Ports.....	63
Electrical Connections Overview	63
Connection Details Controller	65
Technical Data	71
Ambient Conditions.....	71
Standards and Regulations.....	71
Mechanical and Electrical Data	72
Dimensions	74
Optional Modules	75
Fieldbus Combinations.....	75
Communication Module Realtime Ethernet	75
Overview	75
Mechanical Installation	76
Electrical Connections	78
Communication Module PROFIBUS DP	87
Overview	87
Mechanical Installation	88
Electrical Connections	89
Appendices	91
Disposal	92
Disposal.....	92
Index	93

Safety Information

Important Information

Read these instructions carefully, and look at the equipment to become familiar with the device before trying to install, operate, service, or maintain it. The following special messages may appear throughout this documentation or on the equipment to warn of potential hazards or to call attention to information that clarifies or simplifies a procedure.



The addition of this symbol to a “Danger” or “Warning” safety label indicates that an electrical hazard exists which will result in personal injury if the instructions are not followed.



This is the safety alert symbol. It is used to alert you to potential personal injury hazards. Obey all safety messages that follow this symbol to avoid possible injury or death.

⚠ DANGER
DANGER indicates a hazardous situation which, if not avoided, will result in death or serious injury.

⚠ WARNING
WARNING indicates a hazardous situation which, if not avoided, could result in death or serious injury.

⚠ CAUTION
CAUTION indicates a hazardous situation which, if not avoided, could result in minor or moderate injury.

NOTICE
NOTICE is used to address practices not related to physical injury.

Please Note

Electrical equipment should be installed, operated, serviced, and maintained only by qualified personnel. No responsibility is assumed by Schneider Electric for any consequences arising out of the use of this material.

A qualified person is one who has skills and knowledge related to the construction and operation of electrical equipment and its installation, and has received safety training to recognize and avoid the hazards involved.

QUALIFICATION OF PERSONNEL

Only appropriately trained persons who are familiar with and understand the contents of this manual and all other pertinent product documentation are authorized to work on and with this product.

The qualified person must be able to detect possible hazards that may arise from parameterization, modifying parameter values and generally from mechanical, electrical, or electronic equipment. The qualified person must be familiar with the

standards, provisions, and regulations for the prevention of industrial accidents, which they must observe when designing and implementing the system.

INTENDED USE

The products described or affected by this document, together with software, accessories, and options, are programmable logic controllers (referred to herein as “logic controllers”), intended for industrial use according to the instructions, directions, examples, and safety information contained in the present document and other supporting documentation.

The product may only be used in compliance with all applicable safety regulations and directives, the specified requirements, and the technical data.

Prior to using the product, you must perform a risk assessment in view of the planned application. Based on the results, the appropriate safety-related measures must be implemented.

Since the product is used as a component in an overall machine or process, you must ensure the safety of persons by means of the design of this overall system.

Operate the product only with the specified cables and accessories. Use only genuine accessories and spare parts.

Any use other than the use explicitly permitted is prohibited and can result in unanticipated hazards.

About the Document

Document Scope

Read and understand the material contained in this manual before you work on the controller for the first time. Take particular note of the safety information, page 10. As described in the section *Qualification of Personnel*, page 5, only those persons who meet the *Selection and qualification of employees* are allowed to work at the controller.

A copy of this manual must be available for personnel who work at the controller.

This manual is supposed to help you use the capabilities of the controller safely and properly.

Follow the instructions within this manual to:

- Avoid risks
- Reduce repair costs and downtime of the controller
- Increase the service life of the controller
- Increase reliability of the controller

Validity Note

This document has been updated for the release of EcoStruxure™ Machine Expert V2.2.

The characteristics of the products described in this document are intended to match the characteristics that are available on www.se.com. As part of our corporate strategy for constant improvement, we may revise the content over time to enhance clarity and accuracy. If you see a difference between the characteristics in this document and the characteristics on www.se.com, consider www.se.com to contain the latest information.

General Cybersecurity Information

In recent years, the growing number of networked machines and production plants has seen a corresponding increase in the potential for cyber threats, such as unauthorized access, data breaches, and operational disruptions. You must, therefore, consider all possible cybersecurity measures to help protect assets and systems against such threats.

To help keep your Schneider Electric products secure and protected, it is in your best interest to implement the cybersecurity best practices as described in the *Cybersecurity Best Practices* document.

Schneider Electric provides additional information and assistance:

- Subscribe to the Schneider Electric security newsletter.
- Visit the *Cybersecurity Support Portal* web page to:
 - Find Security Notifications.
 - Report vulnerabilities and incidents.
- Visit the *Schneider Electric Cybersecurity and Data Protection Posture* web page to:
 - Access the cybersecurity posture.
 - Learn more about cybersecurity in the cybersecurity academy.
 - Explore the cybersecurity services from Schneider Electric.

Available Languages of the Document

The document is available in these languages:

- English (EIO0000001501)
- German (EIO0000001502)

Related Documents

Document title	Reference
Lexium 62 Hardware Guide	EIO0000003738 (ENG); EIO0000003740(GER);
Lexium 52 Hardware Guide	EIO0000001347 (ENG); EIO0000001348 (GER);
Lexium 62 ILM Hardware Guide	EIO0000001351 (ENG); EIO0000001352 (GER);
SH3 Servo motor, Motor manual	0198441113987 (ENG); 0198441113988 (FRE); 0198441113986 (GER); 0198441113990 (SPA); 0198441113989 (ITA); 0198441113991 (CHS);
Cybersecurity Guidelines for EcoStruxure Machine Expert, Modicon and PacDrive Controllers and Associated Equipment.	EIO0000004242 (ENG)
How can I... Reduce Vulnerability to Cyber Attacks	Cybersecurity_STN_v2 (ENG)
Cybersecurity Assessment – The Most Critical Step to Secure an Industrial Control System	998-20298472 (ENG)
Effective Implementation of Cybersecurity Countermeasures in Industrial Control Systems	998-20304108_GMA-US (ENG)

To find documents online, visit the Schneider Electric download center (www.se.com/ww/en/download/).

Information on Non-Inclusive or Insensitive Terminology

As a responsible, inclusive company, Schneider Electric is constantly updating its communications and products that contain non-inclusive or insensitive terminology. However, despite these efforts, our content may still contain terms that are deemed inappropriate by some customers.

Terminology Derived from Standards

The technical terms, terminology, symbols and the corresponding descriptions in this manual, or that appear in or on the products themselves, are generally derived from the terms or definitions of international standards.

In the area of functional safety systems, drives and general automation, this may include, but is not limited to, terms such as *safety*, *safety function*, *safe state*, *fault*, *fault reset*, *malfunction*, *failure*, *error*, *error message*, *dangerous*, etc.

Among others, these standards include:

Standard	Description
IEC 61131-2:2007	Programmable controllers, part 2: Equipment requirements and tests.
ISO 13849-1:2015	Safety of machinery: Safety related parts of control systems. General principles for design.
EN 61496-1:2013	Safety of machinery: Electro-sensitive protective equipment. Part 1: General requirements and tests.
ISO 12100:2010	Safety of machinery - General principles for design - Risk assessment and risk reduction
EN 60204-1:2006	Safety of machinery - Electrical equipment of machines - Part 1: General requirements
ISO 14119:2013	Safety of machinery - Interlocking devices associated with guards - Principles for design and selection
ISO 13850:2015	Safety of machinery - Emergency stop - Principles for design
IEC 62061:2015	Safety of machinery - Functional safety of safety-related electrical, electronic, and electronic programmable control systems
IEC 61508-1:2010	Functional safety of electrical/electronic/programmable electronic safety-related systems: General requirements.
IEC 61508-2:2010	Functional safety of electrical/electronic/programmable electronic safety-related systems: Requirements for electrical/electronic/programmable electronic safety-related systems.
IEC 61508-3:2010	Functional safety of electrical/electronic/programmable electronic safety-related systems: Software requirements.
IEC 61784-3:2016	Industrial communication networks - Profiles - Part 3: Functional safety fieldbuses - General rules and profile definitions.
2006/42/EC	Machinery Directive
2014/30/EU	Electromagnetic Compatibility Directive
2014/35/EU	Low Voltage Directive

In addition, terms used in the present document may tangentially be used as they are derived from other standards such as:

Standard	Description
IEC 60034 series	Rotating electrical machines
IEC 61800 series	Adjustable speed electrical power drive systems
IEC 61158 series	Digital data communications for measurement and control – Fieldbus for use in industrial control systems

Finally, the term *zone of operation* may be used in conjunction with the description of specific hazards, and is defined as it is for a *hazard zone* or *danger zone* in the *Machinery Directive (2006/42/EC)* and *ISO 12100:2010*.

NOTE: The aforementioned standards may or may not apply to the specific products cited in the present documentation. For more information concerning the individual standards applicable to the products described herein, see the characteristics tables for those product references.

Specific Safety Information

Overview

This chapter contains important safety information regarding working with the controller. The controller conforms to recognized technical safety regulations.

Product Related Information

Overview

Health and safety risks arising from the controller have been reduced. However a residual risk remains, since the controller works with electrical voltage and electrical currents.

If activities involve residual risks, a safety message is made at the appropriate points. This includes potential hazard(s) that may arise, their possible consequences, and describes preventive measures to avoid the hazard(s).

Electrical Parts

DANGER

HAZARD OF ELECTRIC SHOCK, EXPLOSION OR ARC FLASH

- Disconnect all power from all equipment including connected devices prior to removing any covers or doors, or installing or removing any accessories, hardware, cables, or wires except under the specific conditions specified in the appropriate hardware guide for this equipment.
- Always use a properly rated voltage sensing device to confirm the power is off where and when indicated.
- Replace and secure all covers, accessories, hardware, cables, and wires and confirm that a proper ground connection exists before applying power to the unit.
- Use only the specified voltage when operating this equipment and any associated products.

Failure to follow these instructions will result in death or serious injury.

DANGER

ELECTRIC SHOCK, EXPLOSION, OR ARC FLASH

- Operate electrical components only with a connected protective ground (earth) cable.
- After the installation, verify the secure connection of the protective ground (earth) cable to all electrical devices to ensure that connection complies with the connection diagram.
- Before enabling the device, safely cover the live components to prevent contact.
- Do not touch the electrical connection points of the components when the module is energized.
- Provide protection against indirect contact.
- Connect and disconnect cables and terminals only after you have verified that the power has been removed from the system.

Failure to follow these instructions will result in death or serious injury.

Assembly and Handling

This product has a leakage (touch) current greater than 3.5 mA. If the protective ground connection is interrupted, a hazardous leakage (touch) current may flow if the housing is touched.

⚠ DANGER

INSUFFICIENT GROUNDING

- Use a protective ground copper conductor with at least 10 mm² (AWG 6) or two protective ground copper conductors with the same or larger cross section of the conductors supplying the power terminals.
- Verify compliance with all local and national electrical code requirements as well as all other applicable regulations with respect to grounding of all equipment.

Failure to follow these instructions will result in death or serious injury.

⚠ WARNING

CRUSHING, SHEARING, CUTTING AND HITTING DURING HANDLING

- Observe the general construction and safety regulations for handling and assembly.
- Use appropriate mounting and transport equipment and use appropriate tools.
- Prevent clamping and crushing by taking appropriate precautions.
- Cover edges and angles to protect against cutting damage.
- Wear appropriate protective clothing (for example, protective goggles, protective boots, protective gloves).

Failure to follow these instructions can result in death, serious injury, or equipment damage.

⚠ WARNING

UNINTENDED EQUIPMENT OPERATION

- Use appropriate safety interlocks where personnel and/or equipment hazards exist.
- Install and operate this equipment in an enclosure appropriately rated for its intended environment and secured by a keyed or tooling locking mechanism.
- Use the sensor and actuator power supplies only for supplying power to the sensors or actuators connected to the module.
- Power line and output circuits must be wired and fused in compliance with local and national regulatory requirements for the rated current and voltage of the particular equipment.
- Do not use this equipment in safety-critical machine functions unless the equipment is otherwise designated as functional safety equipment and conforming to applicable regulations and standards.
- Do not disassemble, repair, or modify this equipment.
- Do not connect any wiring to reserved, unused connections, or to connections designated as No Connection (N.C.).

Failure to follow these instructions can result in death, serious injury, or equipment damage.

Hazardous Movements

There can be different sources of hazardous movements:

- No, or incorrect, homing of the drive
- Wiring or cabling errors
- Errors in the application program
- Component errors
- Error in the measured value and signal transmitter

NOTE: Provide for personal safety by primary equipment monitoring or measures. Do not rely only on the internal monitoring of the drive components. Adapt the monitoring or other arrangements and measures to the specific conditions of the installation in accordance with a risk and error analysis.

⚠ DANGER

UNAVAILABLE OR INADEQUATE PROTECTION DEVICE(S)

- Prevent entry to a zone of operation with, for example, protective fencing, mesh guards, protective coverings, or light barriers.
- Dimension the protective devices properly and do not remove them.
- Do not make any modifications that can degrade, incapacitate, or in any way invalidate protection devices.
- Before accessing the drives or entering the zone of operation, bring the drives and the motors they control to a stop.
- Protect existing workstations and operating terminals against unauthorized operation.
- Position EMERGENCY STOP switches so that they are easily accessible and can be reached quickly.
- Validate the functionality of EMERGENCY STOP equipment before start-up and during maintenance periods.
- Prevent unintentional start-up by disconnecting the power connection of the drive using the EMERGENCY STOP circuit or using an appropriate lock-out tag-out sequence.
- Validate the system and installation before the initial start-up.
- Avoid operating high-frequency, remote control, and radio devices close to the system electronics and their feed lines, and perform, if necessary, an EMC validation of the system.

Failure to follow these instructions will result in death or serious injury.

Drive systems may perform unanticipated movements because of incorrect wiring, incorrect settings, incorrect data or other errors.

⚠ WARNING

UNINTENDED MOVEMENT OR MACHINE OPERATION

- Carefully install the wiring in accordance with the EMC requirements.
- Do not operate the product with undetermined settings and data.
- Perform comprehensive commissioning tests that include verification of configuration settings and data that determine position and movement.

Failure to follow these instructions can result in death, serious injury, or equipment damage.

PELV Circuits

The signal voltage and the control voltage of the devices are less than 30 Vdc and have to be designed as PELV (Protective Extra Low Voltage) circuits. In this range, the specification as PELV system, according to IEC 61800-5-1 requires a protective measure against direct and indirect contact with hazardous voltage through an implemented separation in the system/machine of the primary and the

secondary side. Separate high and low voltage wiring and respect the standard IEC 61800-5-1, Adjustable speed electrical power drive systems - safety requirements.

⚠ WARNING

POTENTIAL OF OVERHEATING AND FIRE

- Do not connect the equipment directly to line voltage.
- Use only isolating PELV power supplies and circuits to supply power to the equipment¹.

Failure to follow these instructions can result in death, serious injury, or equipment damage.

¹ For compliance to UL (Underwriters Laboratories) requirements, the power supply must also conform to the various criteria of NEC Class 2, and be inherently current limited to a maximum power output availability of less than 100 VA (approximately 4 A at nominal voltage), or not inherently limited but with an additional protection device such as a circuit breaker or fuse meeting the requirements of clause 9.4 Limited-energy circuit of UL 61010-1. In all cases, the current limit should never exceed that of the electric characteristics and wiring diagrams for the equipment described in the present documentation. In all cases, the power supply must be grounded, and you must separate Class 2 circuits from other circuits. If the indicated rating of the electrical characteristics or wiring diagrams are greater than the specified current limit, multiple Class 2 power supplies may be used.

Cybersecurity

Cybersecurity is a branch of network administration that addresses attacks on or by computer systems and through computer networks that can result in accidental or intentional disruptions.

The objective of cybersecurity is to help provide increased levels of protection for information and physical assets from theft, corruption, misuse or accidents while maintaining access for their intended users.

Schneider Electric adheres to industry best practices in the development and implementation of control systems. This includes a "Defense-in-Depth" approach to secure an Industrial Control System. This approach places the controllers behind one or more firewalls to restrict access to authorized personnel and protocols only.

⚠ WARNING

UNAUTHENTICATED ACCESS AND SUBSEQUENT UNAUTHORIZED MACHINE OPERATION

- Evaluate whether your application environments are connected to your critical infrastructure and, if so, take appropriate steps in terms of prevention, based on Defense-in-Depth, before connecting the automation system to any network.
- Limit the number of devices connected to a network to the minimum necessary.
- Isolate your industrial network from other networks inside your company.
- Protect any network against unintended access by using firewalls, VPN, or other, proven security measures, such as an Intrusion Prevention System or Intrusion Detection System.
- Monitor activities within your systems.
- Prevent subject devices from direct access or direct link by unauthorized parties or unauthenticated actions.
- Install certificates that are issued by publicly known Trusted Certificate Authorities.
- Keep your systems up-to-date and rely only on legitimate sources.
- Prepare a recovery plan including backup of your system and process information.

Failure to follow these instructions can result in death, serious injury, or equipment damage.

For more information on organizational measures and rules covering access to infrastructures, refer to ISO/IEC 27000 series, Common Criteria for Information Technology Security Evaluation, ISO/IEC 15408, IEC 62351, ISA/IEC 62443, NIST Cybersecurity Framework, Information Security Forum - Standard of Good Practice for Information Security, and refer to Cybersecurity Guidelines for EcoStruxure Machine Expert, Modicon and PacDrive Controllers and Associated Equipment.

For detailed information on the defense-in-depth approach, refer to: How can I... Reduce Vulnerability to Cyber Attacks.

To submit a cybersecurity question, report security issues, or get the latest news from Schneider Electric, visit the Schneider Electric website.

Password Management

- Change the passwords every 90 days
- Use a unique password (not related to your personal password)

Backing-up and Restoring the Software Configuration

To protect your data, back-up the system and configuration and keep your backup file in a secure place.

Intended Use

Installation

Install and operate this equipment in a control cabinet (enclosure) appropriately rated for its intended environment and secured by a keyed or tooled locking mechanism.

Provide for Protective Measures

Before installing the device, provide for appropriate protective devices in compliance with local and national standards. Do not commission components without appropriate protective devices. After installation, commissioning, or repair, test the protective devices used.

Perform a risk evaluation concerning the specific use before operating the product and take appropriate safety measures.

▲ WARNING

UNINTENDED EQUIPMENT OPERATION

Ensure that a risk assessment is conducted and respected according to EN/ISO 12100 during the design of your machine.

Failure to follow these instructions can result in death, serious injury, or equipment damage.

If circumstances occur that affect the safety or cause changes to the operating behavior of the controllers, then immediately shut down the controllers and contact your Schneider Electric representative.

Use Original Equipment Only

Use only the accessories and mounting parts specified in the documentation and no third-party devices or components that have not been expressly approved by Schneider Electric.

There are no user-serviceable parts within the PacDrive LMC Eco components. Either replace the component or contact the Schneider Electric Customer Service.

▲ WARNING

UNINTENDED EQUIPMENT OPERATION

- Only use software and hardware components approved by Schneider Electric for use with this equipment.
- Do not attempt to service this equipment outside of authorized Schneider Electric service centers.
- Update your application program every time you change the physical hardware configuration.

Failure to follow these instructions can result in death, serious injury, or equipment damage.

Environment Restrictions

The components must not be used in the following environments:

- In hazardous (explosive) atmospheres
- In mobile, movable, or floating systems
- In life support systems
- In domestic appliances
- Underground

This equipment has been designed to operate outside of any hazardous location. Only install this equipment in zones known to be free of a hazardous atmosphere.

⚠ DANGER

POTENTIAL FOR EXPLOSION

Install and use this equipment in non-hazardous locations only.

Failure to follow these instructions will result in death or serious injury.

System Overview

Overview

The control system consists of several components, depending on its application.

PacDrive 3 system overview

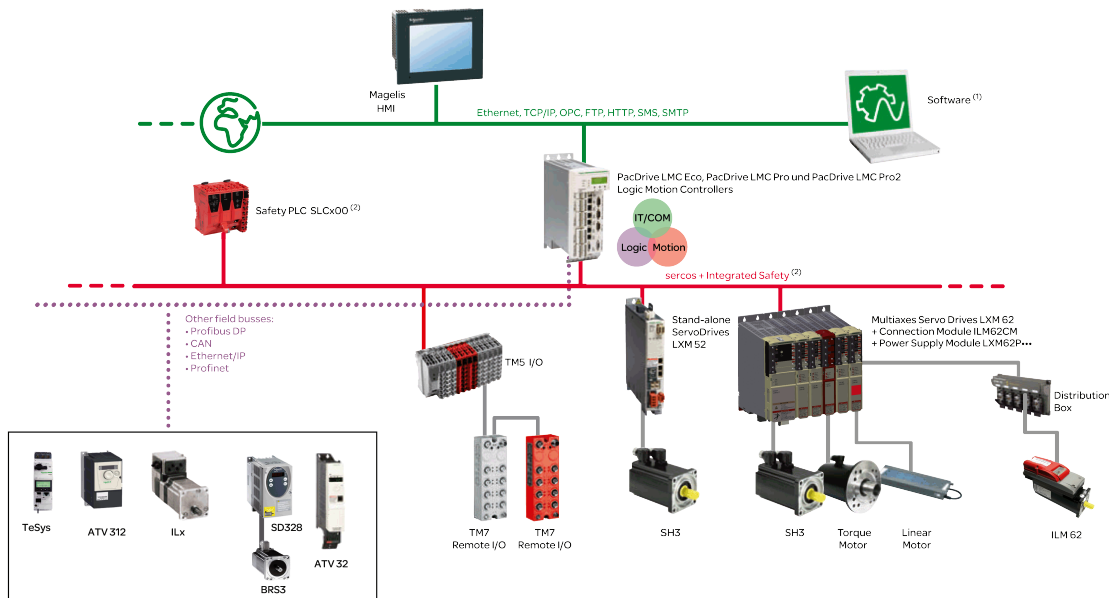

- 1 EcoStruxure Machine Expert Software
- 2 Safety Logic Controller according to IEC 61508 and ISO 13849

Logic Motion Controller

Overview

Product	Description
	<p>The PacDrive LMC (Logic Motion Controller), with a VxWorks real-time operating system, centrally implements the Logic Controller and motion functions. A PacDrive LMC synchronizes, coordinates, and creates the motion functions of a machine for a maximum of:</p> <ul style="list-style-type: none"> • 0 Sercos servo drives for the controller PacDrive LMC100 • 4 Sercos servo drives for the controller PacDrive LMC101 • 6 Sercos servo drives for the controller PacDrive LMC106 • 8 Sercos servo drives for the controller PacDrive LMC201 • 12 Sercos servo drives for the controller PacDrive LMC212 • 16 Sercos servo drives for the controller PacDrive LMC216 • 8 Sercos servo drives for the controller PacDrive LMC300 • 8 Sercos servo drives for the controller PacDrive LMC302 • 16 Sercos servo drives for the controller PacDrive LMC400 • 16 Sercos servo drives for the controller PacDrive LMC402 • 99 Sercos servo drives for the controller PacDrive LMC600 • 130 Sercos servo drives for the controller PacDrive LMC802 • 130 Sercos servo drives for the controller PacDrive LMC902

Lexium 62 Drive System

Overview

The modular servo drive system Lexium 62 Drive System is designed for the operation of servo drives in a multi-axes system.

The power electronic components of the Lexium 62 Drive System are fitted inside the control cabinet.

Lexium 62 Power Supply



Using a common DC bus, the central power supply unit Lexium 62 Power Supply supplies the connected servo converters with the power required.

The central Lexium 62 Power Supply, using a common DC bus, supplies the connected Lexium 62 Servo Drives with the power required.

Lexium 62 Connection Module

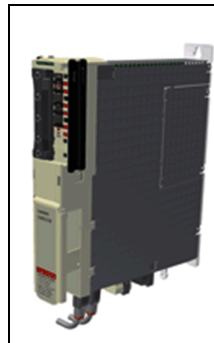

The Lexium 62 Connection Module supplies the Lexium 62 ILMs with DC voltage from the DC bus via a hybrid cable or via a power cable (daisy chain wiring). Additionally, the Lexium 62 Connection Module provides the Inverter Enable and Sercos interface.

The Lexium 62 Drive System helps simplify the wiring of the devices in relation to the initial start-up and in service cases. This also applies to the cable connection of the enclosed devices to the field. All the connectors that can be connected from the outside (power input, DC bus, 24 Vdc supply, Sercos, Ready, and Inverter Enable) are designed such, that a fast and simple configuration without tools can be realized on the device.

Lexium 62 Distribution Box



The Lexium 62 Distribution Box is the link between Lexium 62 Connection Module and Lexium 62 ILM. Depending on the number of drives, 1 to 4 Lexium 62 ILMs or daisy chain lines can be connected. When operating more than four drives, simply expand the system using one or more Lexium 62 Distribution Box.

The highlights:

- 1...4 connections for Lexium 62 ILMs or daisy chain lines or further Lexium 62 Distribution Box
- Easy wiring using pre-assembled hybrid cables or power cables (daisy chain wiring)
- Easy to expand

Lexium 62 ILM



The innovative Lexium 62 ILM combines motor, power stage, and digital servo controller for an axis in a space-saving housing. Due to its compact construction with the integrated controller, it is perfectly suitable for peripheral setup. It is available with individual or multi-turn encoders and configures itself with the aid of the electronic nameplate in the Lexium 62 ILM.

The Lexium 62 ILMs are available in three different flange sizes:

- ILM070
- ILM100
- ILM140

The highlights:

- Compact type of construction
- 3.5 times peak torque
- Integrated Sercos interface
- High-resolution single or multi-turn encoder
- Degree of protection IP65
- Simple wiring

ILM Daisy Chain Connector Box

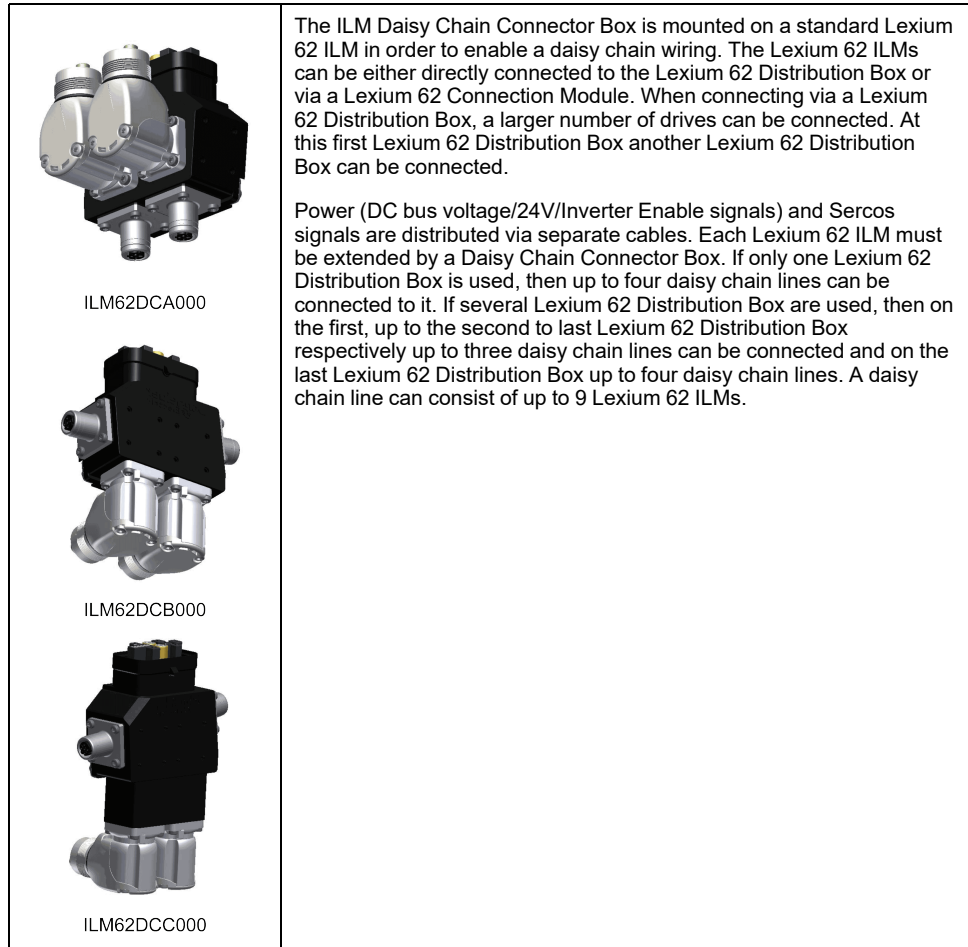

The connection between the Lexium 62 ILMs is established as follows:

- Power cable for power distribution (DC bus voltage/24 V/Inverter Enable signals) with an M23 connector
- Sercos cable for distribution of the Sercos signals via M12 connector

The following Lexium 62 ILMs can be equipped with the Daisy Chain Connector Box in order to implement a daisy chain wiring:

- ILM070••
- ILM100••
- ILM140••

The Daisy Chain Connector Box is available in the following variants:

- ILM62DCA000 (suitable for ILM070••, ILM100•• and ILM140••)
- ILM62DCB000 (suitable for ILM070•• only)
- ILM62DCC000 (suitable for ILM100•• only)

Lexium 52

Overview

Product	Description
	<p>The stand-alone Lexium 52 Sercos servo amplifier is designed for servo drive solutions with independent single axes, or other applications involving asynchronous motors.</p> <p>The power electronic components of the Lexium 52 are fitted inside the control cabinet. The drive provides the phase currents required for the position control of the connected motors. According to the different requirements in relation to the individual servo axes of the application, the Lexium 52 is available in different current classes. The Lexium 52 helps simplify the wiring in relation to the initial start-up and service cases. This also applies to the cable connection of the enclosed devices to the field. All the connectors that can be connected from the outside (power input, DC bus, 24 Vdc supply, Sercos, motor, encoder, I/Os, I/O supply, Ready and Inverter Enable (STO)) are designed so that a fast, simple configuration on the device can be realized.</p>

References

Product	Reference
Drive	LXM52DU60C LXM52DD12C LXM52DD18C LXM52DD30C LXM52DD72C

Lexium 62 Servo Drive

Overview

The servo drive system Lexium 62 is used for the operation of servo drives in a multi-axis group.

The power electronic components of the Lexium 62 are fitted inside the control cabinet.

Product	Description
	<p>The Lexium 62 Servo Drives provide the necessary phase currents for the position control of the connected servo motors. The Lexium 62 Servo Drives includes Lexium 62 Single Drives and/or Lexium 62 Double Drives.</p> <p>In addition, Lexium 62 Servo Drives are suitable for applications involving asynchronous motors.</p> <p>According to the different requirements in relation to the individual servo axes of the application, the Lexium 62 Servo Drives are available in different current classes.</p> <p>The Lexium 62 helps to simplify the wiring of the drives. This also applies to the cable connection of the enclosed drives to the field. The connectors that can be connected from the outside (power input, DC bus, 24 Vdc supply, Sercos, motor, encoder, I/O modules, I/O supply, Ready, and Inverter Enable) are designed so that a fast, simple configuration on the drive can be realized.</p>

SH3 Servo Motor

Overview

Product	Description
	<p>The SH3 motors are low-inertia AC synchronous servo motors designed for highly dynamic positioning tasks.</p> <p>A drive system consists of the servo motor and the drive. Maximum performance requires the motor and drive to be adapted to each other.</p>

High Dynamic AC Servo Motors

Because of the low inertia and a high overload capability, the motor SH3 fulfills many requirements concerning the accuracy, dynamics, and efficiency.

The SH3 motors are available in six different flange sizes:

- SH3-040 (40 mm / 1.57 in.)
- SH3-055 (55 mm / 2.17 in.)
- SH3-070 (70 mm / 2.76 in.)
- SH3-100 (100 mm / 3.94 in.)
- SH3-140 (140 mm / 5.51 in.)
- SH3-205 (205 mm / 8.07 in.)

Characteristics

The motors have the following features:

- Overload protection by integrated temperature sensor (external evaluation required)
- Low moment of inertia
- High power density
- Excellent dynamics

- High overload capability
- Broad torque range
- Special winding for low phase currents
- Motor connection via circular connectors
- Easy commissioning via electronic nameplate in SinCos encoder
- Low maintenance

Options and Accessories

The motors are available with various options such as:

- Various encoder systems
- Holding brake
- Various shaft versions
- Various degrees of protection
- Various lengths
- Various sizes
- Various connection versions

For further information, refer to the *SH3 Servo Motor - User Guide*.

TM5 System

Overview

The direct connection of the TM5 System to the PacDrive LMC Eco is not possible. The TM5 System can be connected via the Sercos bus interface.

Type Code

Overview

The graphic shows the type code PacDrive LMC Eco:

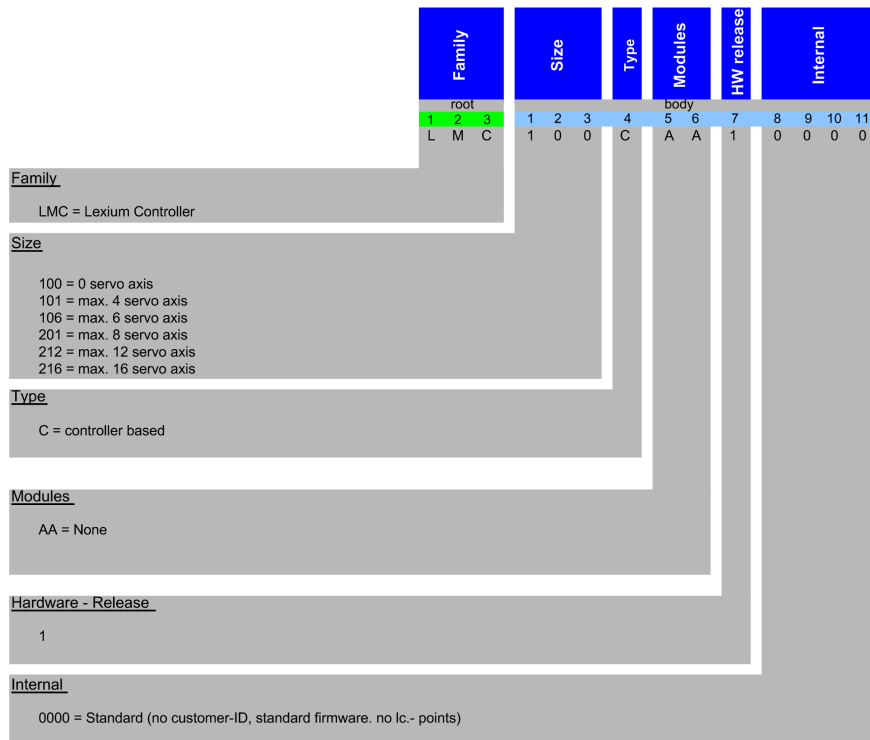

Nameplate Descriptions

Overview

The technical nameplate of the Logic Motion Controller (LMC) drive is located on the left bottom side of the housing.

Explanation of the technical nameplate entries:

Label	Description
LMCxxxCxxxxxx	Device type and Unicode
Input d.c.	Digital inputs / input voltage and input current (per input)
Output d.c.	Digital outputs / output voltage and rated current (per input)
IP20	Degree of protection
CE (symbol)	CE mark

The logistical nameplate of the LMC is located on top of the housing.

Label	Description
LMC101CAA10000	Device type and Unicode
907156.0010	Serial number
RS:02	Hardware revision ⁽¹⁾

Label	Description
DOM	Date of manufacture
<p>(1) When replacing the controller, page 43, the hardware revision for the previous and the new device should be identical to help avoid potential compatibility issues with the equipment. The hardware revision can also be read from the hardware code in the device, page 58. For more information on the compatibility of different hardware revisions, contact your local Schneider Electric representative.</p>	

Engineering

Electromagnetic Compatibility, EMC

Electromagnetic Disturbances of Signals and Devices

This product meets the EMC requirements in accordance with the standard IEC 61131-2, provided that the EMC measures described in this manual are complied with during installation.

⚠ WARNING
<p>SIGNAL AND EQUIPMENT INTERFERENCE</p> <ul style="list-style-type: none"> • Install the wiring in accordance with the EMC requirements described in the present document. • Verify compliance with the EMC requirements described in the present document. • Verify compliance with all EMC regulations and requirements applicable in the country in which the product is to be operated and with all EMC regulations and requirements applicable at the installation site. <p>Failure to follow these instructions can result in death, serious injury, or equipment damage.</p>

⚠ WARNING
<p>ELECTROMAGNETIC DISTURBANCES OF SIGNALS AND DEVICES</p> <p>Use proper EMC shielding techniques to help prevent unintended device operation in accordance with the standard IEC 61800-3.</p> <p>Failure to follow these instructions can result in death, serious injury, or equipment damage.</p>

These types of devices are not intended to be used on a low-voltage public network which supplies domestic premises. Radio frequency interference is expected if used in such a network.

⚠ WARNING
<p>RADIO INTERFERENCE</p> <p>Do not use these products in domestic electrical networks.</p> <p>Failure to follow these instructions can result in death, serious injury, or equipment damage.</p>

Layout Control Cabinet (Enclosure)

The prerequisite for compliance with the specified limit values is an EMC compatible layout. Depending on the application, the following measures can improve the EMC-dependent values:

EMC measures	Objective
Use galvanized or chromium-plated sub plates, bond metallic parts across large surface areas, remove paint layer from contact surfaces.	Good conductivity by surface area contact.
Ground control cabinet (enclosure), door, and sub plates by using grounding strips or	Reduce emission.

EMC measures	Objective
grounding cables with a cross-section of 10 mm ² (AWG 6).	
Supplement switch devices such as contactors, relays, or magnetic valves with interference suppression combinations or spark suppressor elements (for example, diodes, varistors, RC elements).	Reduces mutual interference.
Fit power and control components separately.	Reduces mutual interference.

Shielded Cables

EMC measures	Objective
Connect large surface areas of cable shields, use cable clamps and ground straps.	Reduce emission.
Ground shields of digital signal wires at both ends by connecting them to a large surface area or via conductive connector housings.	Reduce interference action on signal cables, reduce emissions.
Ground shield of analog signal cables directly on the device (signal input), insulate the shield at the other cable end or ground the same through a capacitor, such as 10 nF.	Reduce grounding loops by low frequency interferences.

Cable Installation

EMC measures	Objective
Do not route fieldbus cables and signal wires in a single cable duct together with lines with DC and AC voltages of more than 60 V. (Fieldbus cables, signal lines, and analog lines may be in the same cable duct). Electromagnetic immunity will improve by routing cables in separated cable ducts with a distance of at least 20 cm (7.84 in).	Reduces mutual interference.
Keep cables as short as possible. Do not install unnecessary cable loops, use short cables from the central grounding point in the control cabinet to the external ground connection.	Reduces capacitive and inductive interference.
Use equipotential bonding conductors (stranded wire of equal potential at all grounding locations connected to an equipotential grounding plane) in the following cases: wide-area installations, different voltage supplies, and installation across several buildings.	Reduces current in the cable shield, reduces emissions.
Use stranded wire potential equalization conductor.	Discharging of high frequency interference currents.
If motor and machine are not conductively connected, for example by an insulated flange or a connection without surface contact, you must ground the motor with a ground strap or a ground wire. The conductor cross section must be at least 10 mm ² (AWG 6).	Reduces emissions, increases immunity.
Use twisted pair for 24 Vdc signals.	Reduce interference action on signal cables, reduce emissions.

Power Supply

EMC measures	Objective
Operate product on mains with grounded neutral point.	Enables effectiveness of mains filter.
Use surge arrester if there is a risk of overvoltage.	Reduces the risk of damage caused by overvoltage.

Motor and Encoder Cables

From an EMC perspective, motor supply cables and encoder cables are particularly important. Only use pre-configured cables, or cables with the prescribed properties, and comply with the following EMC measures.

EMC measures	Objective
Do not install switching elements in motor cables or encoder cables.	Reduces interference.
Route motor cable with a distance of at least 20 cm (7.84 in) to the signal cables or insert shield plates between the motor supply cable and the signal cable.	Reduces mutual interference.
For wiring that approaches the maximum cable distance specification (75 m/ 246.06 ft.), use equipotential bonding connection cables.	Reduce current on cable shield.
Route motor supply cables and encoder cables without any separation point ⁽¹⁾ .	Reduces emission.
⁽¹⁾ If a cable must be cut through for installation purposes, the cables must be connected at the point of separation by using screen connections and metal housing.	

Additional Measures for Improving the EMC

Depending on the respective application, the following measures may lead to an EMC compatible layout:

EMC measures	Objective
Upstream connection of mains line reactor (choke)	Reduction of the harmonic network oscillations, extension of the service life of the product.
Upstream connection of external mains filters	Improvement of the EMC limit values.
Special EMC-appropriate layout, for example, within an enclosed control cabinet complete with 15 dB attenuation of using the interferences emitted	Improvement of the EMC limit values.

Control Cabinet Planning

Degree of Protection (IP)

Overview

Install components such that a degree of protection corresponding to the actual operational environment is set up.

For more information on the degree of protection of the equipment, refer to *Ambient Conditions*, page 71.

The following conditions may damage the components:

- Oil
- Moisture
- Electromagnetic interference
- Ambient temperature
- Metal dust deposits

▲ WARNING

UNINTENDED EQUIPMENT OPERATION

- Prevent the formation of moisture during the operation, storage and transport of individual components.
- Conform to the vibration and shock requirements specified for the equipment when operating, storing and transporting system equipment.

Failure to follow these instructions can result in death, serious injury, or equipment damage.

Mechanical and Climatic Environmental Conditions in the Control Cabinet

Overview

Step	Action
1	Observe the climatic and mechanical ambient conditions. For more information on the general climatic and mechanical environmental conditions according to IEC 60721, refer to <i>Ambient Conditions</i> , page 71.
2	Verify the technical data of the device whether the permitted deviations (for example, higher shock load or higher temperature) are specified.

Using Cooling Units

Installing a Cooling Unit

How to proceed when installing a cooling unit:

Step	Action
1	Position the cooling units so that no condensate drips out of the cooling unit onto electronic components or is sprayed by the cooling air flow.
2	Provide specially designed control cabinets for cooling units on the top of the control cabinet.
3	Design the control cabinet so that the cooling unit fan cannot spray any accumulated condensate onto the electronic components when it restarts after a pause.
4	When using cooling units, use only well-sealed control cabinets so that warm, humid outside air, which causes condensation, does not enter the cabinet.
5	When operating control cabinets with open doors during commissioning or maintenance, ensure that the electronic components are at no time cooler than the air in the control cabinet after the doors are shut, in order to avoid any condensation.
6	Continue to operate the cooling unit even when the system is switched off, so that the temperature of the air in the control cabinet and the air in the electronic components remains the same.

Step	Action
7	Set cooling unit to a fixed temperature of 40 °C or lower (104 °F).
8	For cooling units with temperature monitoring, set the temperature limit to 40 °C (104 °F) so that the internal temperature of the control cabinet does not fall below the external air temperature.

⚠ WARNING

UNINTENDED EQUIPMENT OPERATION

Follow the installation instructions such that the condensation from the cooling unit can not enter electrical equipment.

Failure to follow these instructions can result in death, serious injury, or equipment damage.

Installing a cooling unit

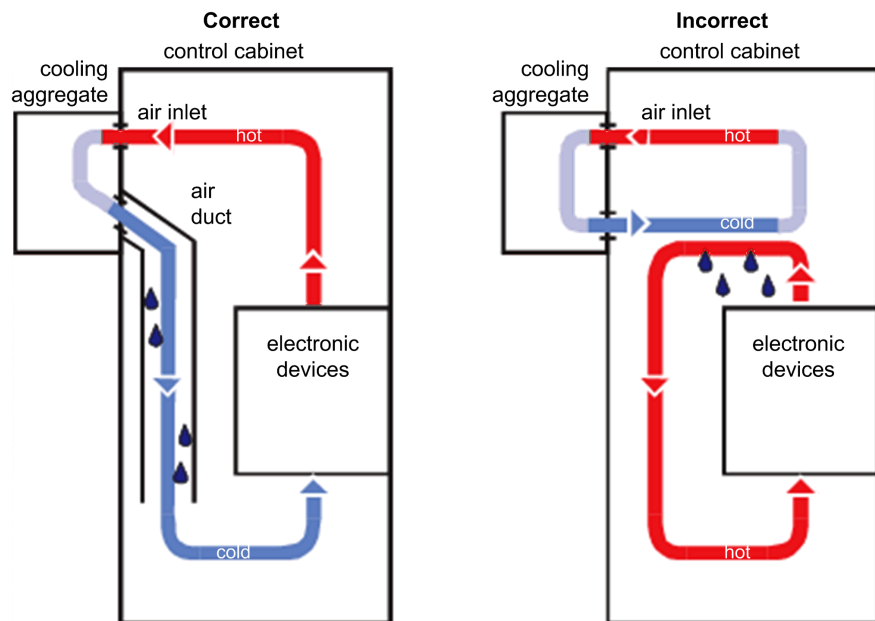

Information about Wiring

General Information about Wiring

Overview

Use only Schneider Electric approved devices in your application, and especially Schneider Electric pre-fabricated cables, wherever and whenever possible.

Observe and implement the following points when wiring:

1. Observe the minimum cross-sections of the cables necessary for the load carrying capacity of the equipment being connected.
2. Verify the integrity of cable shields to ensure continuity to ground.
3. Ensure that there is a proper, equipotential connection to ground for all interconnected equipment.
4. Eliminate any ground loops.
5. Do not disconnect cable connection terminals when under power.
6. Ensure that all ground connections have sufficient surface area continuity.

If, for example, two parallel conductors are shown as coming from one point, you may not run just one conductor and then branch it off at a later point. If it is wired this way, induction loops (interference emitters and antennas) as well as interfering potential shifts may occur.

⚠ DANGER

INCORRECT OR UNAVAILABLE GROUNDING

Remove paint across a large surface at the installation points before installing the devices (bare metal connection).

Failure to follow these instructions will result in death or serious injury.

Cable Characteristics

Overview

Cable characteristics of the Sercos cable (see the Schneider Electric catalog for the various cables available):

Property	Value
Voltage isolation (jacket)	300 Vdc
Temperature range	-20...+60 °C / -4...+140 °F
Cable diameter	5.8 ± 0.2 mm (0.23 ± 0.008 in.)
Bending radius	8 x diameter (fixed routing)
Sheath	PVC, flame-retardant
Cable type and shielding	CAT6 with S/FTP (Sercos III)

Configuring and Coding the Cables

Overview

For configuring and coding the cables, use the appropriate connector kit supplied with the device.

Accessory part	Number	Connection designation
Connector digital inputs	2	CN7
Connector digital outputs	2	CN8
Connector supply voltage	1	CN9
Connector TM5 (not used)	1	CN10
Sercos cable 130 mm (5.11 in)	1	CN5, CN6
Coding pin	6	CN7, CN8, CN9, CN10

ESD Protection Measures

General

Observe the following instructions to help avoid damages due to electrostatic discharge:

NOTICE

ELECTROSTATIC DISCHARGE

- Do not touch any of the electrical connections or components.
- Prevent electrostatic charges, for example, by wearing appropriate clothing.
- If you must touch circuit boards, do so only on the edges.
- Remove existing static charge by touching a grounded, metallic surface.

Failure to follow these instructions can result in equipment damage.

Installation and Maintenance

Commissioning

Prerequisites for Commissioning

Prerequisites

⚠️⚠️ DANGER

HAZARD OF ELECTRIC SHOCK, EXPLOSION OR ARC FLASH

- Disconnect all power from all equipment including connected devices prior to removing any covers or doors, or installing or removing any accessories, hardware, cables, or wires except under the specific conditions specified in the appropriate hardware guide for this equipment.
- Always use a properly rated voltage sensing device to confirm the power is off where and when indicated.
- Replace and secure all covers, accessories, hardware, cables, and wires and confirm that a proper ground connection exists before applying power to the unit.
- Use only the specified voltage when operating this equipment and any associated products.

Failure to follow these instructions will result in death or serious injury.

⚠️ DANGER

ELECTRIC SHOCK, EXPLOSION, OR ARC FLASH

- Operate electrical components only with a connected protective ground (earth) cable.
- After the installation, verify the secure connection of the protective ground (earth) cable to all electrical devices to ensure that connection complies with the connection diagram.
- Before enabling the device, safely cover the live components to prevent contact.
- Do not touch the electrical connection points of the components when the module is energized.
- Provide protection against indirect contact.
- Connect and disconnect cables and terminals only after you have verified that the power has been removed from the system.

Failure to follow these instructions will result in death or serious injury.

Preparing Commissioning

Prerequisite

Verify safety-related circuits for proper function, if applicable.

ESD Protection

Observe the following instructions to help avoid damages due to electrostatic discharge:

NOTICE

ELECTROSTATIC DISCHARGE

- Do not touch any of the electrical connections or components.
- Prevent electrostatic charges, for example, by wearing appropriate clothing.
- If you must touch circuit boards, do so only on the edges.
- Remove existing static charge by touching a grounded, metallic surface.

Failure to follow these instructions can result in equipment damage.

Unpacking

How to unpack the device:

Step	Action
1	Remove packaging
2	Dispose of the packaging material in accordance with the relevant local regulations.

Verifying

How to verify the device:

Step	Action
1	Verify that the delivery is complete, based on the delivery slip.
2	Closely inspect the device for any signs of damage.
3	Verify the data with the help of the nameplates.
4	Observe requirements for the installation location.
5	Then install LMC.

⚠ WARNING

UNINTENDED EQUIPMENT OPERATION

- Do not mount or commission damaged equipment.
- Do not modify the equipment.
- Send back inoperative equipment.

Failure to follow these instructions can result in death, serious injury, or equipment damage.

Preparing the Control Cabinet

Overview

⚠ DANGER

INCORRECT OR UNAVAILABLE GROUNDING

Remove paint across a large surface at the installation points before installing the devices (bare metal connection).

Failure to follow these instructions will result in death or serious injury.

Step	Action
1	If necessary to maintain and respect the maximum ambient operating temperature, install additional fan in the control cabinet.
2	Do not block the fan air inlet of the product.
3	Keep a distance of at least 100 mm (3.94 in) above and below the products.
4	Mount the controller vertically inside the control cabinet.

Assembly Distances, Ventilation

Assembly distances and air circulation:

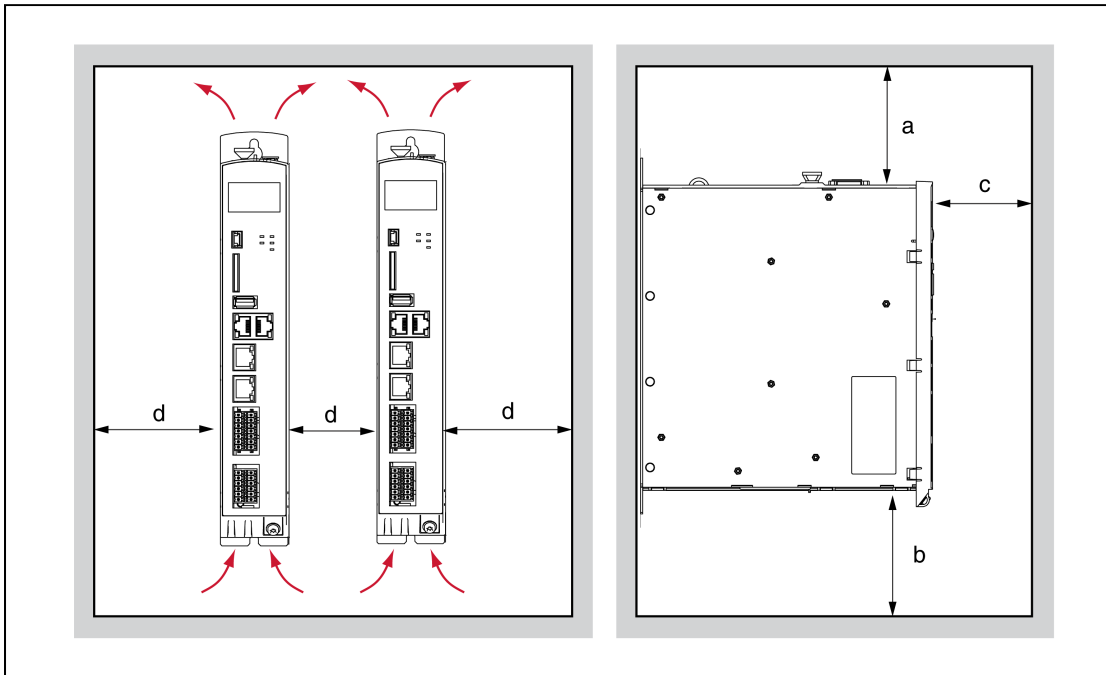

Distance	Air circulation
$a \geq 100 \text{ mm (3.94 in)}$	Clearance above the device.
$b \geq 100 \text{ mm (3.94 in)}$	Clearance below the device.
$c \geq 60 \text{ mm (2.36 in)}$	Clearance in front of the device.
$d \geq 0 \text{ mm (0 in)}$	Clearance between the devices or between the device and the side of the enclosure.

Required Distances

Required distances in the control cabinet for the PacDrive LMC Eco, Lexium 62 Power Supply, Lexium 62 Servo Drive:

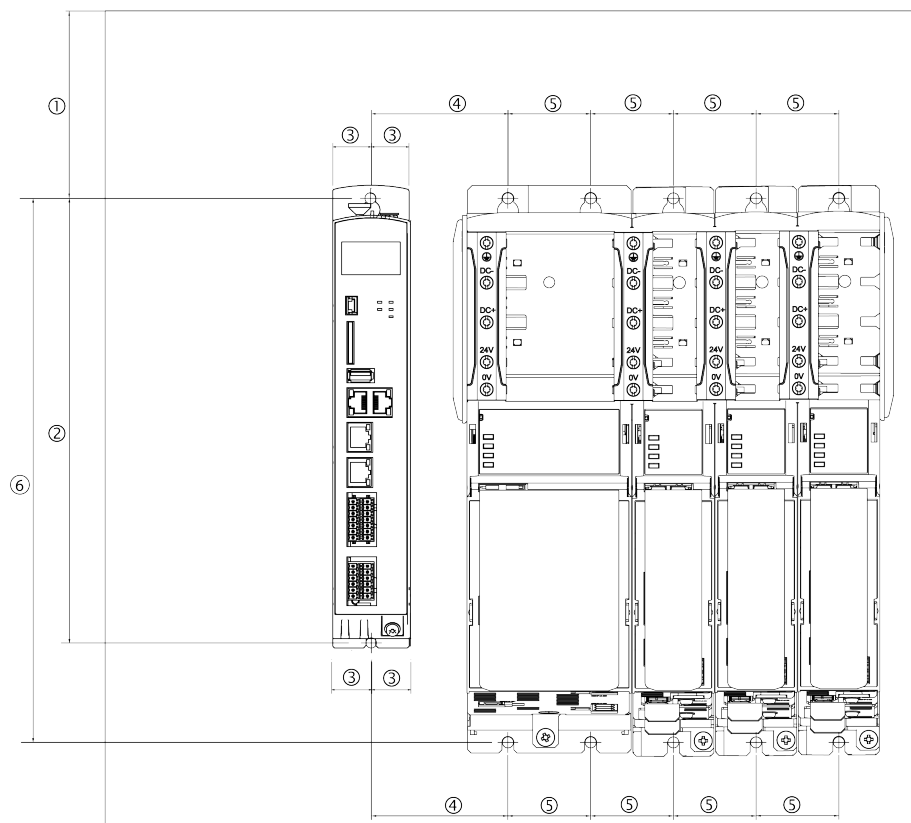

-	mm	in	Thread
(1)	100 (± 0.2)	3.94 (± 0.01)	M6
(2)	258 (+ 0.5 / -0)	10.16 (± 0.02 / -0)	M6
(3)	22 (± 0.2)	0.87 (± 0.01)	M5
(4)	55 (± 0.2)	2.17 (± 0.01)	M6
(5)	45 (± 0.2)	1.77 (± 0.01)	M6
(6)	296 (+ 0.5 / -0)	11.65 (± 0.02 / -0)	M6

NOTE: For the shield plates (external shield connections), additional holes are required.

Mechanical Mounting

Procedure

Step	Action
1	Screw the pan-head screws M5 (socket head cap screws) into the prepared mounting holes.
2	Keep a distance of 10 mm (0.39 in) between the screw head and the mounting plate.
3	Hook in device and verify the vertical mounting arrangement.
4	Tighten the mounting screws (torque: 2.8 Nm (24.78 lbf in)).

Wiring of the Controller

Before Applying Power to Your Controller for the First Time

For information on the connections mentioned hereafter, refer to the *Electrical Connections Overview*, page 63.

To wire the controller, proceed as follows:

Step	Action
1	Be sure that the controller is first connected to the ground (functional earth) before proceeding with other connections.
2	Verify the continuity of the grounding system of your application.
3	Verify that all cable shields are properly connected to the functional earth of the application.
4	Verify that the memory card has been inserted.
5	Eliminate the possibility of short circuits and interruptions.
6	Verify that the terminals are fastened securely and the cable cross sections (gauge) are as required.
7	Connect the CN9 connection of the controller to an appropriate power supply.
8	<p>Establish a Sercos connection via the CN5 and/or CN6 connections.</p> <p>NOTE: If Sercos devices are assigned via the topological addresses (IdentificationMode = TopologyAddress) to the PacDrive LMC Eco, then consider the following:</p> <ul style="list-style-type: none"> • Connect your Sercos device to the PacDrive LMC Eco either completely via Sercos port 1 (CN5) in line topology or in ring topology using Sercos port 1 and 2 (CN5/CN6). • Do not connect the Sercos devices to the PacDrive LMC Eco via double line topology (CN5/CN6). • Do not connect the Sercos devices to the PacDrive LMC Eco only via Sercos port 2 (CN6).
9	Connect all further connections according to the requirements of your application.
10	<p>Power on the supply voltage to the controller.</p> <p>Result: The LMC is initialized and the LEDs show the following condition:</p> <ul style="list-style-type: none"> • LED status during initialization: State LED: red • LED status after initialization: State LED: green

DANGER

INSUFFICIENT GROUNDING

- Use a protective ground copper conductor with at least 10 mm² (AWG 6) or two protective ground copper conductors with the same or larger cross section of the conductors supplying the power terminals.
- Verify compliance with all local and national electrical code requirements as well as all other applicable regulations with respect to grounding of all equipment.

Failure to follow these instructions will result in death or serious injury.

WARNING

UNINTENDED EQUIPMENT OPERATION

Verify the connection of the control voltage to the inputs and outputs.

Failure to follow these instructions can result in death, serious injury, or equipment damage.

Refer to the chapter *Electrical Connection Overview*, page 63.

Configure the Output CN8 as Watchdog

On the connection **CN8**, it is possible to configure the output **DQ7** as watchdog output. By default, the output is configured as standard output.

⚠ WARNING

NON-CONFORMANCE TO SAFETY FUNCTION REQUIREMENTS

Do not use the watchdog output to realize any safety function.

Failure to follow these instructions can result in death, serious injury, or equipment damage.

For more information on safety functions, consult the standards IEC 61508:2010 and EN ISO 13849:2008.

For further information on this, see the online help of EcoStruxure Machine Expert.

Grounding Screw Connection

Tighten the grounding screw with a 1.4 Nm (12.4 lbf in) torque.

External UPS

The controller saves data up to 25 ms after a power outage. To avoid data loss, an external uninterruptible power supply (UPS) should be used.

NOTICE

LOSS OF DATA

Use an external UPS to avoid data loss in case of a power outage.

Failure to follow these instructions can result in equipment damage.

Completion of Commissioning

Transferring the Configuration and the Program

For information on how to transfer the project to the PacDrive controller, refer to the EcoStruxure Machine Expert Online Help.

For programming and configuration of these devices, the software tool SoMachine Motion V4.3 (or later) or EcoStruxure Machine Expert V1.0 (or later) is required.

⚠ WARNING

HAZARDOUS MOVEMENTS

- Ensure that no persons are in the zone of operation.
- Remove all tools, loose parts, and other working aids not belonging to the axis/machine/system from the area of movement.
- Engage the engine only after the function test has been successfully performed.

Failure to follow these instructions can result in death, serious injury, or equipment damage.

Adjust Real-Time Clock

The real-time clock is not adjusted at the time of delivery of the device. Summer and winter time is considered by the device. As of LMC firmware V1.64.x.x, the time zone information is supported. `SysTimeRtcSetTimeZone` allows the configuration (preconfigured for CET). LMC parameter `RealTimeClock` can be set with `SetRealTimeClock` or `SysTimeRtcSet`. If the real-time clock is not adjusted, the time and date specifications in the message logger will not be correct. Make certain that the real-time clock is adjusted correctly.

Performing the Function Test

Overview

Step	Action
1	Verify devices and wiring again.
2	If you have not already done so, connect the power supply.
3	Carry out function test using a checklist for axis/machine/system functions.
4	Resume system operation according to the operating manual (from the machine manufacturer and servo amplifier).

Maintenance, Repair, Cleaning, Replacement Equipment Inventory

Prerequisites for Maintenance, Repair, and Cleaning

Introduction

Observe the following instructions before carrying out maintenance on the controller.

De-Energize the System

 **DANGER**

HAZARD OF ELECTRIC SHOCK, EXPLOSION OR ARC FLASH

- Disconnect all power from all equipment including connected devices prior to removing any covers or doors, or installing or removing any accessories, hardware, cables, or wires except under the specific conditions specified in the appropriate hardware guide for this equipment.
- Always use a properly rated voltage sensing device to confirm the power is off where and when indicated.
- Replace and secure all covers, accessories, hardware, cables, and wires and confirm that a proper ground connection exists before applying power to the unit.
- Use only the specified voltage when operating this equipment and any associated products.

Failure to follow these instructions will result in death or serious injury.

How to de-energize the system:

Step	Action
1	Set main switch to OFF position, or otherwise disconnect all power to the system.
2	Prevent main switch from being switched back on.
3	In the case of any drives, servos or other equipment with high capacity capacitors, wait at least 15 minutes after removing power (switching off) to allow the DC bus capacitors to discharge. For other important hazard information, see the user guide of your drive (s).

Repair

Overview

There are no user-serviceable parts within the PacDrive LMC Eco controller. Either replace the controller or contact your local Schneider Electric service representative

If you replace devices, verify that the replaced devices have at least the same hardware revision or later.

Cleaning

Cleaning the Controller

Step	Action
1	De-energize the controller, page 39.
2	Remove the controller.
3	Blow out the controller with dry pressurized air (maximum 1 bar (14.5 PSI)).

Care must be taken with cleaning products as some active agents may have deleterious effects on plastics and stainless steel welds.

NOTICE
<p>CORROSION CAUSED BY CLEANING AGENTS</p> <ul style="list-style-type: none"> • Before using a cleaning agent, carry out a compatibility test in relation to the cleaning agent and the component affected. • Do not use alkaline detergent. • Do not use any chlorid-containing cleaning agents. <p>Failure to follow these instructions can result in equipment damage.</p>

For more information on the material properties of your component, refer to *Mechanical and Electrical Data*, page 72.

Battery, Real-Time Clock

Overview

The estimated maintenance interval for replacing the battery is 10 years. Only Schneider Electric personnel are authorized to replace the battery. The contact addresses can be found in the chapter *Contact Addresses*.

If the battery is getting low, then the message **Empty Battery** appears on the display.

NOTE: When the battery is empty and the 24 Vdc mains supply is disconnected then data (retain variables and all the data on the NVRAM) is not saved anymore.

NOTE: When the battery is empty, the real-time clock is set to a default value by every start and you have to set the real-time clock to the current value.

Replacement Equipment Inventory

Presentation

Keep a stock of the most important components to make certain your machine is functioning and ready for operation.

Replace devices with the same hardware configuration to help ensure compatibility.

Indicate the following information on the replacement equipment order:

- Unicode: for example, **LMC101C**
- Hardware revision: for example, **RS 01**

This information can be found on the nameplates.

For more information concerning the replacement of components, refer to *Replacing Components and Cables*, page 41.

NOTE: For software and hardware compatibility information, refer to *Compatibility of Lexium 62 Drives and Programming Software Versions* (see EcoStruxure Machine Expert Compatibility and Migration, User Guide).

Replacing Components and Cables

Prerequisites for Replacing Components and Cables

De-Energize the System

⚠ ⚠ DANGER

HAZARD OF ELECTRIC SHOCK, EXPLOSION OR ARC FLASH

- Disconnect all power from all equipment including connected devices prior to removing any covers or doors, or installing or removing any accessories, hardware, cables, or wires except under the specific conditions specified in the appropriate hardware guide for this equipment.
- Always use a properly rated voltage sensing device to confirm the power is off where and when indicated.
- Replace and secure all covers, accessories, hardware, cables, and wires and confirm that a proper ground connection exists before applying power to the unit.
- Use only the specified voltage when operating this equipment and any associated products.

Failure to follow these instructions will result in death or serious injury.

How to de-energize the system:

Step	Action
1	Set main switch to OFF position, or otherwise disconnect all power to the system.

2	Prevent main switch from being switched back on.
3	In the case of any drives, servos or other equipment with high capacity capacitors, wait at least 15 minutes after removing power (switching off) to allow the DC bus capacitors to discharge. For other important hazard information, see the user guide of your drive (s).

Other Prerequisites

⚠ DANGER

ELECTRIC SHOCK, EXPLOSION, OR ARC FLASH

- Operate electrical components only with a connected protective ground (earth) cable.
- After the installation, verify the secure connection of the protective ground (earth) cable to all electrical devices to ensure that connection complies with the connection diagram.
- Before enabling the device, safely cover the live components to prevent contact.
- Do not touch the electrical connection points of the components when the module is energized.
- Provide protection against indirect contact.
- Connect and disconnect cables and terminals only after you have verified that the power has been removed from the system.

Failure to follow these instructions will result in death or serious injury.

⚠ WARNING

UNINTENDED EQUIPMENT OPERATION

- Only use software and hardware components approved by Schneider Electric for use with this equipment.
- Do not attempt to service this equipment outside of authorized Schneider Electric service centers.
- Update your application program every time you change the physical hardware configuration.

Failure to follow these instructions can result in death, serious injury, or equipment damage.

The metal surfaces of the product may exceed 65 °C (149 °F) (for bare metal) during operation.

⚠ WARNING

HOT SURFACES

- Avoid unprotected contact with hot surfaces.
- Do not allow flammable or heat-sensitive parts in the immediate vicinity of hot surfaces.
- Verify that the heat dissipation is sufficient by performing a test run under maximum load conditions.

Failure to follow these instructions can result in death, serious injury, or equipment damage.

Device Replacement

How to Replace the Controller

Before beginning the replacement of specific components, read thoroughly the Prerequisites for Replacing Components and Cables, page 41.

⚠ DANGER
INOPERABLE SAFETY FUNCTION
Test the proper functioning of the safety functions after every device replacement and every change of the wiring.
Failure to follow these instructions will result in death or serious injury.

Observe the following instructions to replace the controller.

Step	Action
1	In order to maintain compatibility with your application and machine, replace the existing controller with that of the same hardware revision (for example, RS:02 on the logistical nameplate, page 24 or 02 in the hardware code, page 53).
2	Contact your Schneider Electric representative if the replacement controller is of a different hardware revision.
3	When replacing the controller, in addition to the following instructions, the specifications of the original machine manufacturer must also be observed.
4	Disconnect cables from the controller.
5	Loosen the mounting screws from the top and bottom of the housing brackets.
6	Remove the controller and replace the complete unit.
7	Install the new controller and tighten the mounting screws.
8	Connect the controller according to the circuit diagram of the machine.
9	Following replacement of the controller, proceed as for the initial start-up.

⚠ DANGER
INCORRECT ASSIGNMENT OF CABLES
Verify that the assignment of the cables conforms to their previous connector assignments.
Failure to follow these instructions will result in death or serious injury.

NOTICE
IMPROPER REPLACEMENT / COMMISSIONING
Do not open the controller for commissioning or replacement.
Failure to follow these instructions can result in equipment damage.

How to Start-Up

Proceed as follows to start up:

Step	Action
1	Import the user project again using a PC on which EcoStruxure Machine Expert Logic Builder is installed. Or Remove the already used flash disk from the controller that has to be repaired and insert it into the new controller.
2	Ensure that the memory card is functional.
3	Put the system back in operation.

Fast Device Replacement (FDR) - Introduction

Introduction

With the help of the Fast Device Replacement, the Lexium 62, Lexium 52 and ILM devices that are in the configuration of an EcoStruxure Machine Expert project in the controller can be replaced.

There are certain parameters that have to be set in EcoStruxure Machine Expert first. Information on this can be found in the online help of EcoStruxure Machine Expert.

Subsequently, certain settings on the display of the controller have to be made which are described below.

The controller interface for FDR allows you to manually access the assignment between logical devices in the controller configuration (EcoStruxure Machine Expert Logic Builder) and the physical connected devices.

Fast Device Replacement - Usage

Error Detected During the Manual Device Assignment

If two or more devices of the same type (or a double drive) are replaced, it is possible that an incorrect manual assignment of the logical devices to the physical connected devices is made.

⚠ WARNING

UNINTENDED OPERATING STATE OF THE DEVICE

- Ensure that the assignment of the logical devices to the physical connected devices is exactly the same as the device assignment before the device replacement.
- Verify that the application addresses the physical drives correctly before putting the machine back into service.

Failure to follow these instructions can result in death, serious injury, or equipment damage.

Different Device Types

The controller interface for FDR does not consider the device type of physical devices.

NOTE: If the logical device type is not the same as the assigned physical device type, then a device assignment with the controller interface for FDR is possible. However, it leads to an error being detected during the Sercos phase start-up (8501 Sercos slave not found). If `FDRStartMode` is set to the value `Phase start-up/2`, then the controller interface for FDR is restarted.

Further information on the parameters can be found under *Fast Device Replacement* in the online help of EcoStruxure Machine Expert.

Device Replacement

If the requirements are fulfilled (see chapter *Fast Device Replacement* in the EcoStruxure Machine Expert online help) and you are replacing a device, then the controller display automatically shows the start picture of the controller interface for FDR.

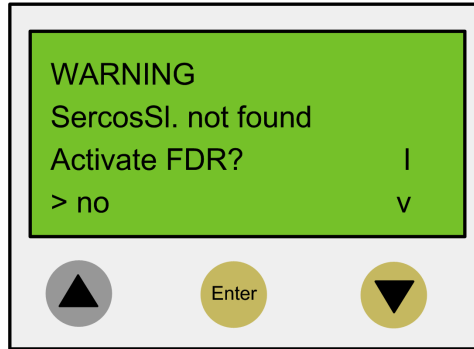

Confirmation or Cancel

Action	Result
You can exit the controller interface for FDR with the Enter key (if the arrow pointing right is on No).	The controller interface for FDR is canceled.
You can also switch to Yes with the arrow pointing down key (arrow pointing right on Yes), and then confirm the Yes with Enter .	Now you can navigate through the menu like described in the chapter <i>Controller Display</i> , page 46. For more information, refer to the chapter <i>Application</i> , page 47.

Timeout (5 Minutes)

If no button is pressed at the display for 5 minutes, the controller interface for FDR is terminated. The system then behaves as if you have terminated the FDR mechanism. If you press a display button within the 5 minutes, the time for the timeout is reset.

Behavior After Repeated Download

If after the controller interface for FDR a download of a project is made, then the saved changes of the parameter `ConfiguredSerialNumber` are reset and set to the values that are saved in the project that was downloaded.

For devices that are identified via **Identification mode > Device number** (`SerialNumberController / 0`) and were allocated via FDR, the system acts as if the controller interface for FDR had not been performed.

Further information on the parameters can be found under *Fast Device Replacement* in the online help of EcoStruxure Machine Expert.







Fast Device Replacement - Controller Display

Overview

When the controller interface for FDR is active, the controller display shows the corresponding menu.

The following describes the menu in general. For more information, refer to the section *Application*, page 47.

General Menu Description

Arrow / Key		Description
		If up/down arrows are displayed at the right menu edge, you can scroll up and down using these arrow keys.
		Scrolling starts only after the right arrow is displayed at the lower or upper menu edge. If the right arrow is displayed in a line in between, you can move it using the up/down arrow keys
	-	The command that is in the line that is marked with the arrow pointing right can be confirmed/executed with the Enter key.
	-	

In the following example, FDR SNRC stands for addressing a device via the device serial number. Instead of FDR SNRC, the FDR ATYP (for application type) or FDR SADR (for Sercos address) can also be used.

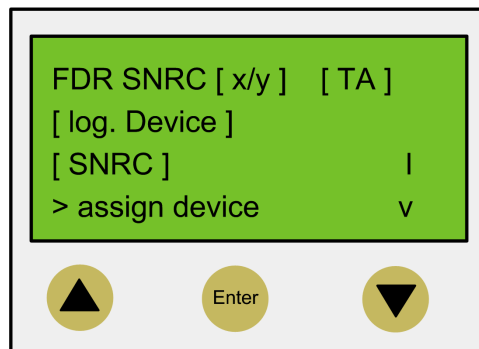

Placeholders	Description
[x/y]	Number of the logic device (x) which currently has to be processed and the total number of the assigned devices (y). If, for example, 20 devices cannot be assigned by default addressing and you have already assigned 11 devices via the controller interface for FDR, then 12/20 is displayed. If this line (for example, FDR SNRC [x/y] [TA]) contains more than 18 characters, then the first 16 characters are displayed, followed by . . . Via the menu item Details , you can switch to a display mode that displays the complete line (see below).
[TA]	Topological address of the physical device that is currently displayed.

Placeholders	Description
[log.device]	<p>Name of the logical device in the controller configuration (EcoStruxure Machine Expert Logic Builder) that shall be assigned to the physical device at the topological address [TA].</p> <p>If the device name consists of more than 18 characters, the first 16 characters of the device name are displayed, followed by . . .</p> <p>Via the menu item Details, you can switch to a display mode that displays the complete logical device name (see below).</p>
[SNRC]	<p>Serial number of the currently displayed physical device on the topological address [TA]</p> <p>If the serial number has more than 18 characters, then the first 16 characters of the serial number are displayed, followed by . . .</p> <p>Via the menu item Details, you can switch to a display mode that displays the complete serial number (see below).</p>

NOTE: Devices that were assigned via the menu item/command **Assign device** (see below) cannot be removed again via a menu item/command.

Menu item/Command	Description
Assign device	<p>With this command, you confirm the assignment between the logical device [log.device] and the physical device at the topological address [TA].</p> <ul style="list-style-type: none"> In the case of Identification mode > Device serial number, the serial number of the physical device is copied to the parameter <code>ConfiguredSerialNumber</code> of the logical device. In the case of Identification mode > Application type, the application type is written to the respective device via the Sercos bus By Identification mode > sercos address, the Sercos address is written to the respective device via the Sercos bus. <p>After assigning a device, the x (see placeholder [x/y]) is increased. If no other devices without an assignment are existent, then the mechanism is completed and the Sercos phase start-up continues.</p>
next phys.	<p>With this command, the next physical device to the logical device (x) that currently has to be processed is displayed.</p>
Details	<p>With this command, it is possible to switch to a display mode that displays the complete lines (multi-line).</p> <p>This is helpful if in the standard view lines cannot be displayed completely (see above).</p> <p>For a logical device, a maximum of 40 characters can be displayed</p>
back	<p>With this command, it is possible to switch back to the standard view (maximum 16 characters followed by . . . are displayed).</p>
Exit FDR	<p>With this command, the controller interface for FDR is canceled.</p> <p>The cancelation has to be confirmed once again (Really exit? > Exit FDR).</p>

Further information on the parameters can be found under *Fast Device Replacement* in the online help of EcoStruxure Machine Expert.

Fast Device Replacement - Application

Starting Conditions

The following example shows a typical application for the controller interface for FDR. For the displayed example, the following applies:

- All the devices are operational.
- The Sercos bus is started up.
- For all the devices, the **Device addressing** via the **Identification mode > Device serial number** was made (parameter `SerialNumberController / 0`).
- The parameter `FDRConfirmationMode` of the controller was set to the value `by Display / 0`.

Further information on the parameters can be found under *Fast Device Replacement* in the online help of EcoStruxure Machine Expert.

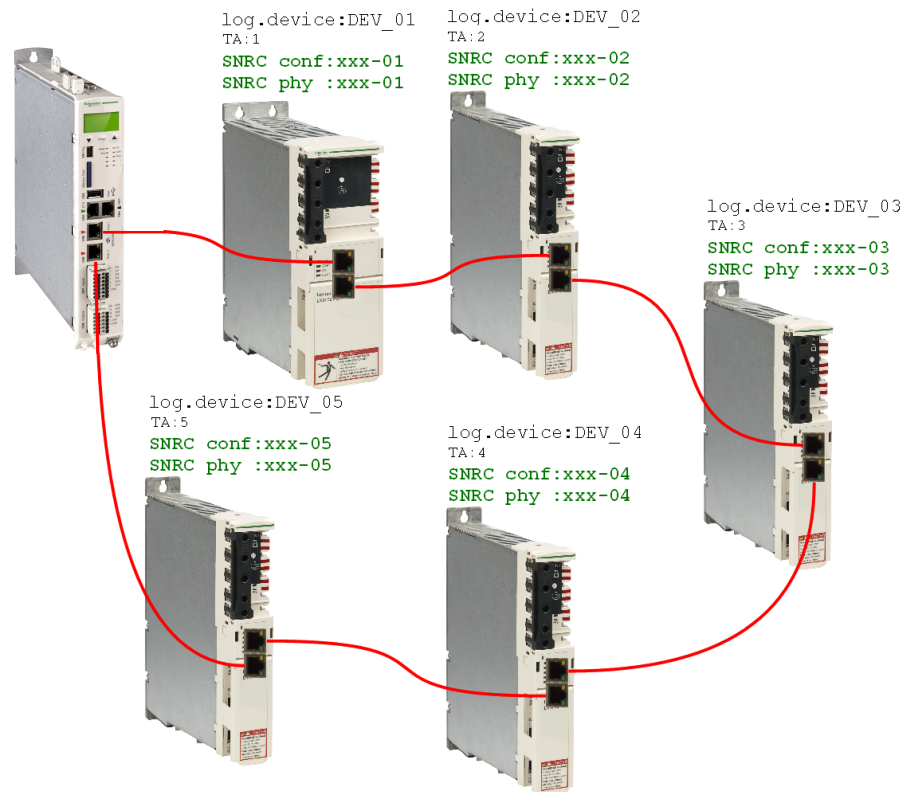

Device Replacement

The following devices have to be replaced because of maintenance:

- The device at the topology address 2 (TA : 2) with the logical device name DEV_02 and the serial number SNRC phy : xxx-02 has to be replaced by the new device that has the serial number SNRC phy : xxx-15.
- The device at the topology address 5 (TA : 5) with the logical device name DEV_05 and the serial number SNRC phy xxx-05 has to be replaced by the new device that has the serial number SNRC phy xxx-16 .

After the Device Replacement

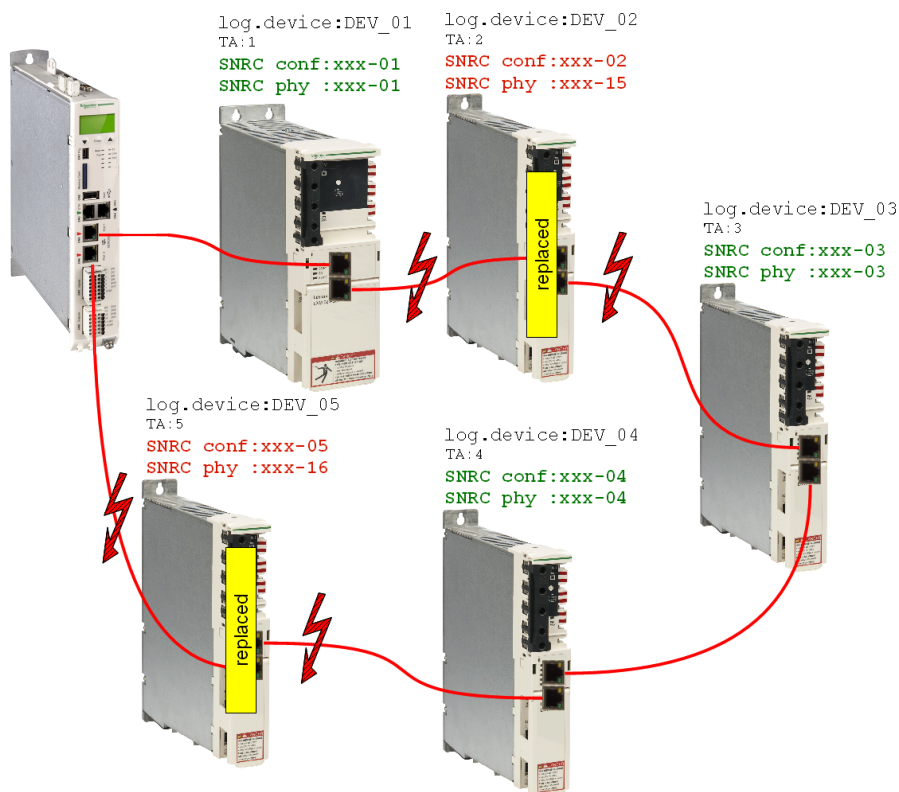

After the physical replacement of the devices the machine has to be restarted again. In order for the controller interface for FDR to be started, the parameter `FDRStartMode` has to be set to `Start/1` or `Phase start-up/2` and the parameter `FDRConfirmationMode` to `by display / 0`.

Now the controller interface for FDR has to find the correct assignment of the two logical devices `DEV_02` and `DEV_05` to the new physically connected devices at topology address 2 and 5.

Further information on the parameters can be found under *Fast Device Replacement* in the online help of EcoStruxure Machine Expert.

Process

The controller interface for FDR verifies all the logical devices one after another which would trigger the diagnostic message 8501 `Sercos slave not found` during the Sercos phase start-up. Afterwards, to the respective logical device all the physical devices are checked until one device is acknowledged.

Due to space constraints, the sequence for device 1 and device 2 is displayed one beneath the other.

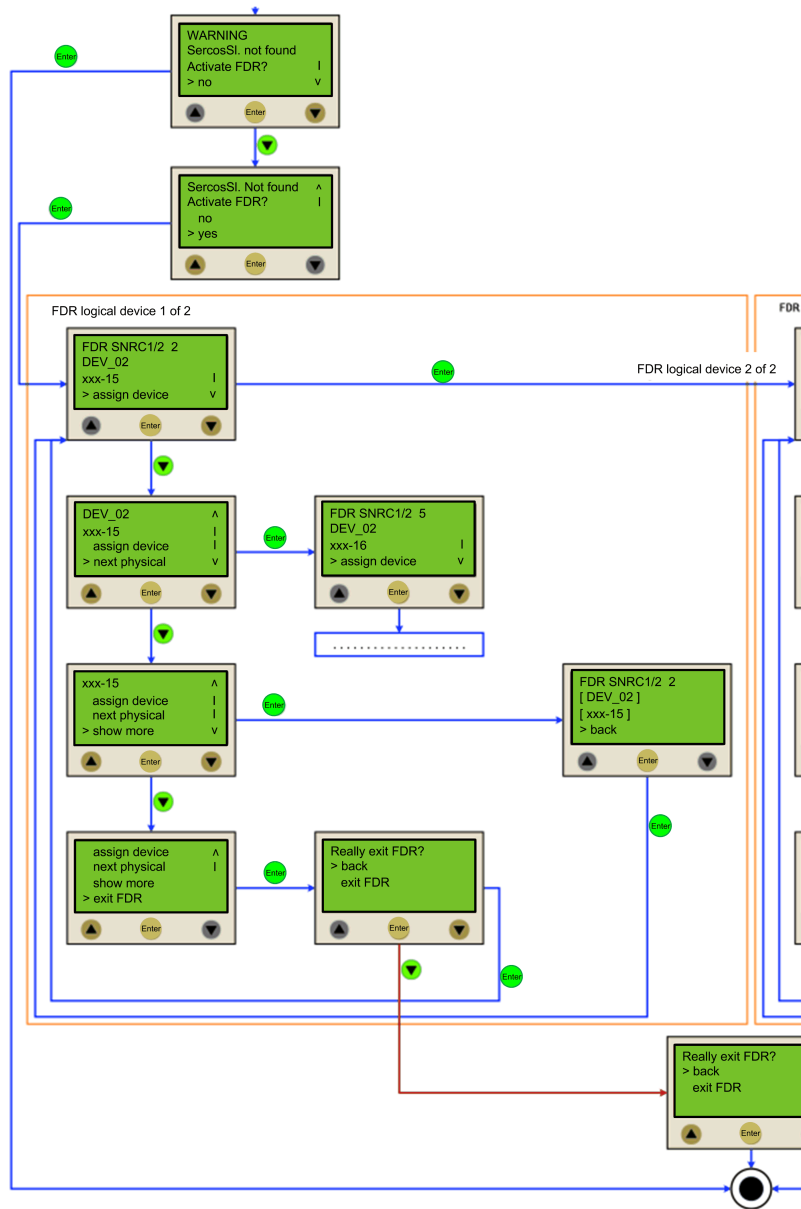

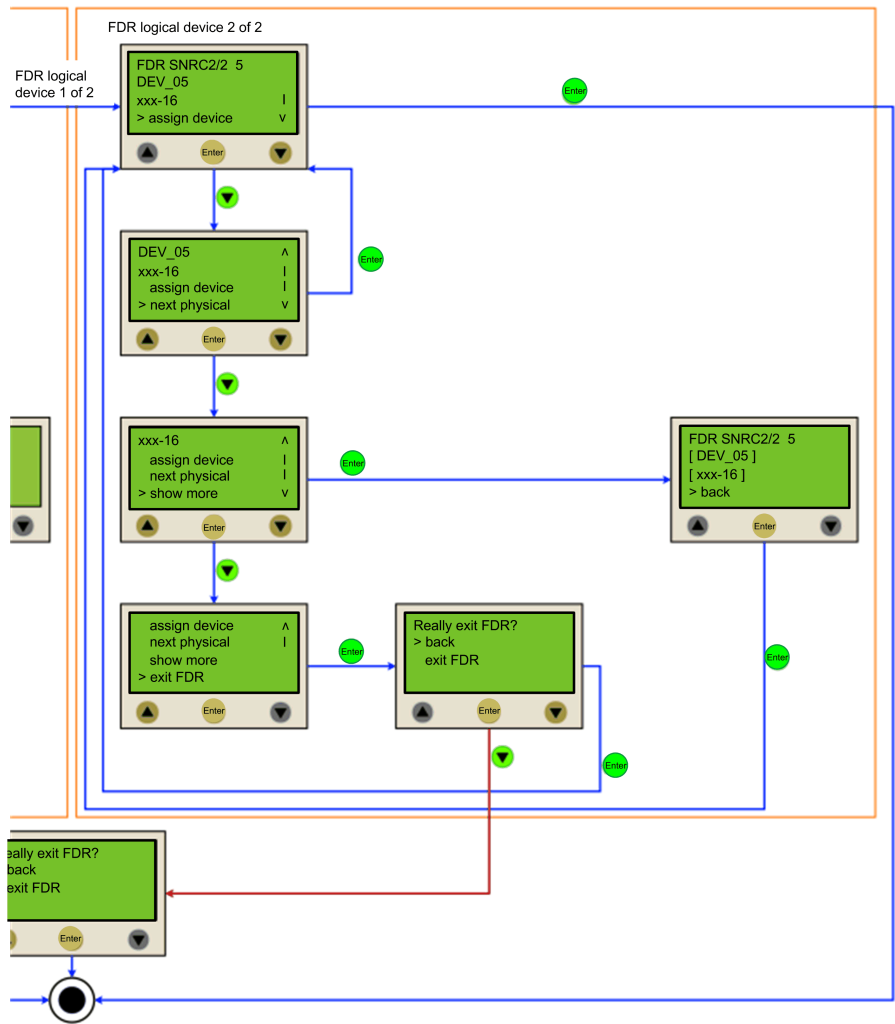

Cable Replacement

Introduction

NOTE: In addition to the following instructions, you must observe the specifications of the machine manufacturer when replacing the cables.

De-Energize the System

⚠️ ⚠️ DANGER

HAZARD OF ELECTRIC SHOCK, EXPLOSION OR ARC FLASH

- Disconnect all power from all equipment including connected devices prior to removing any covers or doors, or installing or removing any accessories, hardware, cables, or wires except under the specific conditions specified in the appropriate hardware guide for this equipment.
- Always use a properly rated voltage sensing device to confirm the power is off where and when indicated.
- Replace and secure all covers, accessories, hardware, cables, and wires and confirm that a proper ground connection exists before applying power to the unit.
- Use only the specified voltage when operating this equipment and any associated products.

Failure to follow these instructions will result in death or serious injury.

How to de-energize the system:

Step	Action
1	Set main switch to OFF position, or otherwise disconnect all power to the system.
2	Prevent main switch from being switched back on.
3	In the case of any drives, servos or other equipment with high capacity capacitors, wait at least 15 minutes after removing power (switching off) to allow the DC bus capacitors to discharge. For other important hazard information, see the user guide of your drive (s).

Procedure

Proceed as follows for cable replacement:

- Be sure that the cables clearly indicate their connections before disconnecting.
- Replace cables with an identical type and length.
- Refer to any documentation from the original machine manufacturer before replacing cables.
- Disconnect/Attach the cable from the equipment components involved.

⚠ DANGER

INCORRECT ASSIGNMENT OF CABLES

Verify that the assignment of the cables conforms to their previous connector assignments.

Failure to follow these instructions will result in death or serious injury.

Indicators and Control Elements

Indicators of the Controller

Overview

Operating unit of the PacDrive LMC Eco

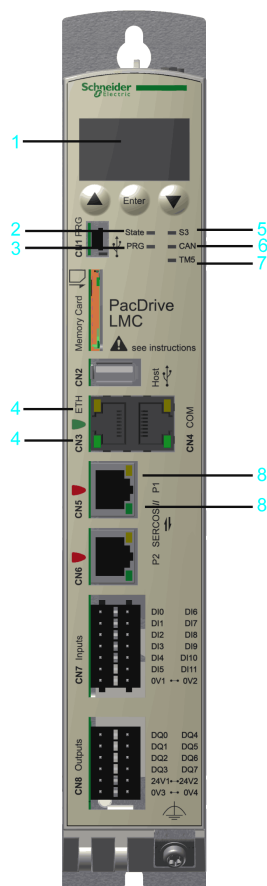

1	Liquid Crystal Display (LCD), page 53
2	State LED indicator, page 54
3	PRG LED indicator, page 54
4	Ethernet status LED indicators, page 55
5	S3 (Sercos III) LED indicator, page 54
6	CAN LED indicator, page 55
7	TM5 LED indicator, page 55
8	Sercos status LED indicators , page 56

Liquid Crystal Display (LCD)

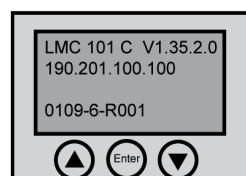

In addition to the LED indicators, further information about the operating status of the controller is given on the 4-line Liquid Crystal Display (LCD).

Line 1	Controller type and firmware version
Line 2	Current IP address of the controller
Line 3	–
Line 4	PFPGA version/SFPGA version/BIOS version

State LED Indicator

The **State** LED indicator indicates whether a control voltage is applied, whether errors are detected by the controller and whether the controller performs a minimum boot.

LED indicator color / status	Meaning
Off	The control voltage (24 Vdc) is missing or too low.
Green	Normal operation, control voltage in normal range
Red	System error detected, error is shown on the display
	Initialization active after power-on
	An error is detected by the controller after initialization , for further information on the detected error, see the message logger.
Quickly flashes red	The controller performs a minimal boot

PRG LED Indicator

The **PRG** LED indicator indicates the state of the USB communication on the programming port (**CN1**).

LED indicator color / status	Meaning
Off	No USB communication on the programming port.
Green	USB communication detected.

NOTE: The function to establish a connection to the controller via USB is not implemented.

S3 (Sercos III) LED Indicator

The **S3** LED indicator indicates the state and the phases of the Sercos communication.

LED indicator color / status	Meaning	Instructions/information for the user	Notes
Off	No Sercos communication	–	–
Orange	The device is in a communication phase CP0 up to and including CP3.	–	SERC3.State = 0..3
Green	Sercos communication in communication phase CP4 without error detected.	–	SERC3.State = 4
Red	Detected communication error.	Reset condition: DiagQuit	SERC3.State = 11

CAN LED Indicator

CAN LED indicator is a two-color light-emitting diode (LED), alternating between two states: a run state (green color) and an error state (red color). **CAN** LED indicator colors can be flashing (different sequences), or steady, as described below.

State	Color display mode	Meaning
Off	–	No power
Flashing green 50 ms/50 ms	The LED indicator repeatedly flashes according to the following sequence: on for 50 ms, then off for 50 ms.	Autobaud detection in progress.
Flashing green 200 ms/200 ms	The LED indicator repeatedly flashes according to the following sequence: on for 200 ms, then off for 200 ms	Pre-operational state
Flashing green 200 ms/1000 ms	Single flash: The LED indicator flashes according to the following sequence: on for 200 ms, then off for 1000 ms	Stopped state
Green	Steady	Operating state.
Flashing red	Single flash: The LED indicator flashes according to the following sequence: on for 200 ms, then off for 1000 ms	Limit to trigger diagnostic message reached
	Double flash: The LED indicator flashes according to the following sequence: on for 200 ms, off for 200 ms, on for 200 ms, then off for 1000 ms	A cyclic checking has detected an error
	Triple flash: The LED indicator flashes according to the following sequence: on for 200 ms, off for 200 ms, on for 200 ms, off for 200 ms, on for 200 ms, then off for 1000 ms	Synchronization error detected. no <code>Sync</code> message received within the configured communication cycle timeout
Red	Steady	Bus off

TM5 LED Indicator

NOTE: The **TM5** LED indicator and TM5 connector **CN10** are not implemented.

Ethernet Status LED Indicators

The Ethernet connector has two LED indicators. One LED indicator is green, the other is yellow.

LED indicator	State	Meaning
Green	On	Connection established
Green	Flashing	Data traffic
Green	Off	No connection, for example, no cable connected, or connected device has no power
Yellow	On	1 GBit/s connection
Yellow	On	100 MBit/s connection
Yellow	Off	10 MBit/s connection

Sercos Status LED indicators

Each Sercos connector has two LED indicators. One LED indicator is green, the other is yellow.

LED indicator	State	Meaning
Yellow	On	Connection established
	Off	No cable connected or connected device has no power.
Green	On	Active network traffic
	Off	No active network traffic

Protocol-specific Status LED Indicators

LED indicators PROFINET device

LED indicator	Color	State	Meaning
SF Name in the device drawing: COM 0	red / green LED indicator		
	Red	On	<ul style="list-style-type: none"> • Watchdog timeout • Detected error on a channel. • Detected system error.
	Red	Flashes at 2 Hz. (for 3 s)	DCP signal service is initiated via the bus.
	Off	Off	No error.
BF Name in the device drawing: COM 1	red / green LED indicator		
	Red	On	<ul style="list-style-type: none"> • No configuration • Low speed physical link • No physical link
	Red	Flashes at 2 Hz.	No data exchange
	Off	Off	No error
LINK/RJ45 Ch0 & Ch1	green LED indicator		
	Green	On	A connection to Ethernet exists.
	Off	Off	The device has no connection to Ethernet.
RX/TX/RJ45 Ch0 & Ch1	yellow LED indicator		
	Yellow	Flashes	The device sends/receives Ethernet frames.

Menu Navigation

Menu Buttons

Three menu buttons are located on the front side of the controller. With these menu buttons, the user can open and navigate through the menu.

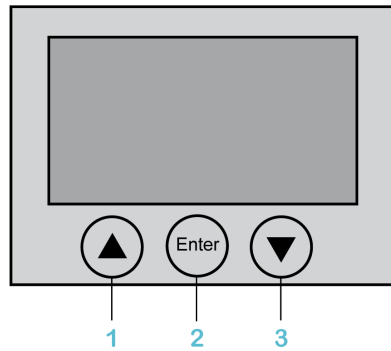







1 Up arrow button

2 Enter button

3 Down arrow button

Functions of the Menu Buttons

Under the Liquid Crystal Display (LCD), three menu buttons are located through which the user can open and navigate in the menu. The menu buttons feature the following functions:

Buttons	Function
First  and then simultaneously 	Access of the menu
	Cursor up
	Cursor down
	Open menu item
First  and then simultaneously 	One level up in the menu

If an up or down arrow is displayed on the right display edge, this indicates that the current menu has more lines than can be shown on the display. In this case, you

can use the arrow buttons  and  to scroll up or down.

Menu Navigation

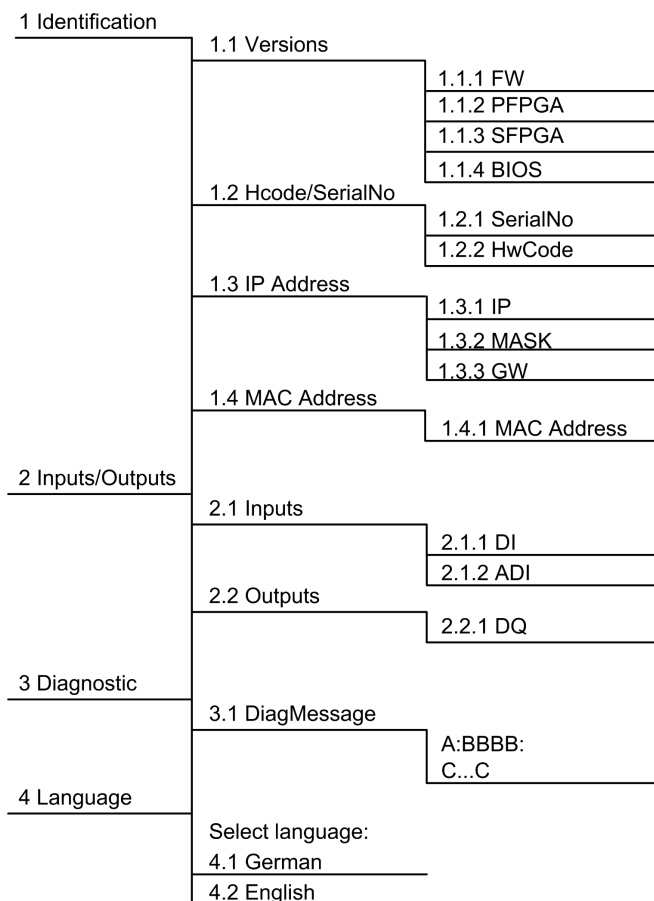

Description of the Menu Navigation

The submenu **Versions** provides an overview of all the software and hardware versions installed on the controller.

Item	Description
FW	Firmware version
PFPGA	Version of the PacDrive FPGA software
SFPGA	Version of the System FPGA software
BIOS	BIOS version

In the submenu **HCode/SerialNo**, a serial number and the hardware code are displayed. The serial number is a unique number which is used to identify the controller. The hardware code indicates the hardware revision.

Item	Description
Serial number	Controller serial number
Hardware code	Hardware code of the controller ⁽¹⁾
⁽¹⁾ The first two digits of the hardware code indicate the hardware revision (for example, 02). The hardware revision is also indicated on the logistical nameplate, page 24 (for example, RS:02). In order to maintain compatibility with your application and machine, replace the existing controller with that of the same hardware code.	

In the submenu **IP address**, the IP address, the subnet mask, and the gateway are displayed.

Item	Description
IP	IP address of the controller
MASK	Subnet mask
GW	Gateway

The MAC address is specified in the submenu **MAC address**. The MAC address is a clear address of the device to identify the device in the network.

Item	Description
MAC address	MAC address

In the submenu **Inputs**, the user can prompt the logic state of each input. The digital inputs correspond to the standard IEC61131-2 type 1. Touchprobes and fast inputs have a resolution of 10 µs. Fast inputs can be used to trigger an interrupt.

Item	Description
DI	Digital input
ADI	Advanced digital input

In the submenu **Outputs**, the user can prompt the logic state of each output.

Item	Description
DQ	Outputs

In the submenu **DiagMessage**, the diagnostic class, the diagnostic code, and the diagnostic text are displayed. The system assigns each diagnostic message a specific diagnostic class when enabled. The diagnostic code is a code that encrypts a certain diagnostic. In the diagnostic text, a diagnostic is described in detail.

Item	Description
A:	A: Diagnostic class
BBB:	BBB: Diagnostic code
C...C	C...C: Diagnostic text

In the submenu **Select language**, the user can choose the display language.

Item	Description
Select language:	
German	Display language is German.
English	Display language is English.

Memory Card Slot (SD Card)

Overview



The memory card slot is located on the front side of the controller.

The memory card slot is the receptacle for the non-volatile data storage (the memory card that can be used is an SD card) of the controller.

General Information on the Memory Card

When handling the memory card, follow these instructions to help prevent a memory card error from occurring, or for internal data on the memory card from being corrupted or lost.

NOTICE

LOSS OF APPLICATION DATA

- Do not store the memory card where there is static electricity or probable electromagnetic fields.
- Do not store the memory card in direct sunlight, near a heater, or other locations where high temperatures can occur.
- Do not bend the memory card.
- Do not drop or strike the memory card against another object.
- Keep the memory card dry.
- Do not touch the memory card connectors.
- Do not disassemble or modify the memory card.
- Use only memory cards formatted using FAT or FAT32.

Failure to follow these instructions can result in equipment damage.

NOTICE

LOSS OF APPLICATION DATA

- Backup memory card data regularly.
- Do not remove power or reset the controller, and do not insert or remove the memory card while it is being accessed.

Failure to follow these instructions can result in equipment damage.

NOTE: To bridge power outages, use an uninterruptible power supply (UPS) if the data being written to the memory card is critical to your application.

The controller saves data up to 25 ms after a power outage. To help to avoid data loss, use an external UPS.

NOTICE

LOSS OF DATA

Use an external UPS to avoid data loss in case of a power outage.

Failure to follow these instructions can result in equipment damage.

Function of the Memory Card

The Schneider Electric firmware is stored on the memory card supplied with the controller. After the system start-up, the firmware is loaded on the controller. You can transfer an EcoStruxure Machine Expert project to the memory card. It is also possible to store license points for libraries on the memory card.

NOTE: Only use memory cards supplied by Schneider Electric for this device.

NOTE: There is no display that shows that the memory card has been accessed.

Write Protection of the Memory Card

With the slide switch on the side of the memory card, the write protection of the memory card can be activated.

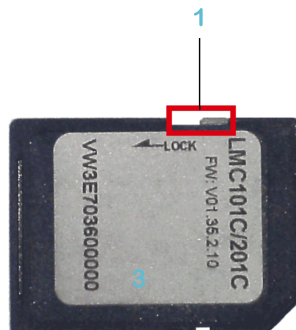

1 Slide switch

To activate the write protection, the slide switch has to be set to the position **LOCK**. To deactivate the write protection, the slide switch has to be set to the opposite position.

NOTE: With an activated write protection, a download of an EcoStruxure Machine Expert project onto the controller or writing of parameters on the memory card is not possible.

Insert Memory Card

Pre-requisite: The controller must be switched off.

NOTICE

INCORRECTLY INSERTED MEMORY CARD

- Do not insert the memory card when the controller is under power.
- Verify that you insert the memory card into the memory card slot correctly with the beveled corner forward and facing downwards.

Failure to follow these instructions can result in equipment damage.

Insert the memory card carefully into the memory card slot with the beveled corner forward and directed downwards as shown on the figure until it snaps into place:

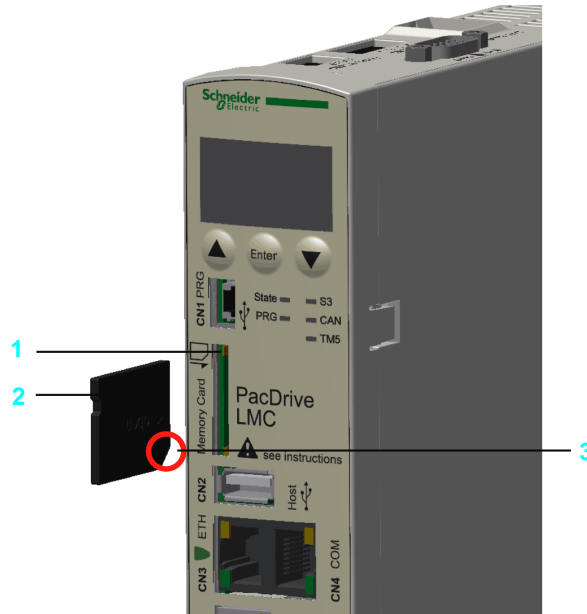

- 1 Memory card slot
- 2 Memory card
- 3 Beveled corner forward and directed downwards

Remove Memory Card

Pre-requisite: The controller must be switched off.

Step	Action
1	Push the memory card slightly inside until it disengages.
2	Remove the memory card from the memory card slot.

NOTICE

INCORRECTLY REMOVED MEMORY CARD

Do not remove the memory card when the controller is under power.

Failure to follow these instructions can result in equipment damage.

USB Connection

Overview

It is possible to connect storage media for the extension of the memory to the connection **CN2** (USB-A). Only a storage medium and no USB-hubs may be connected to the connection

NOTE: The storage medium must only be inserted if the firmware controller is started up. Otherwise the firmware of the controller does not start up.

Integrated Communication Ports

Electrical Connections Overview

Front Panel

Connection overview front panel

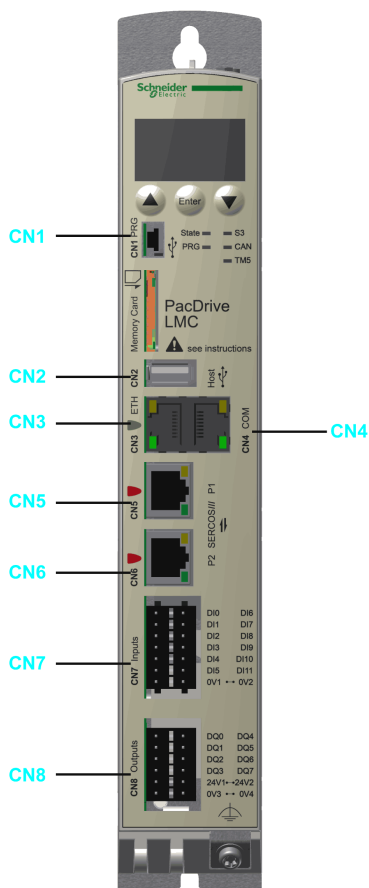

Conne- ction	Meaning	Connection cross- section [mm ²] / [AWG]	Tightening torque [Nm] / [lbf in]
CN1	Prog port (USB mini-b), not active	–	–
CN2	USB A	–	–
CN3	Ethernet connection	–	–
CN4	Serial link (COM)	–	–
CN5	Sercos, port 1	–	–
CN6	Sercos, port 2	–	–
CN7	Digital inputs	0.2...1.5 / 24...16	–
CN8	Digital outputs	0.2...1.5 / 24...16	–

Ferrule dimensions for **CN7**, **CN8**, **CN9**, **CN10**:

Ferrules without insulating collar (according to DIN 46228-1)	
Cross-section [mm ²] / [AWG]	Length [mm] / [in.]
0.25 / 24	7 / 0.28
0.34 / 22	7 / 0.28

Ferrules without insulating collar (according to DIN 46228-1)	
Cross-section [mm ²] / [AWG]	Length [mm] / [in.]
0.5 / 20	8...10 / 0.31...0.40
0.75 / 20	8...10 / 0.31...0.40
1.00 / 18	8...10 / 0.31...0.40
1.50 / 16	10 / 0.40

Ferrules with insulating collar (according to DIN 46228-4)	
Cross-section [mm ²] / [AWG]	Length [mm] / [in.]
0.14 / 26	8 / 0.31
0.25 / 24	8 / 0.31
0.34 / 22	8 / 0.31
0.5 / 20	8...10 / 0.31...0.40
0.75 / 20	10 / 0.40

Top Side

Connection overview top side

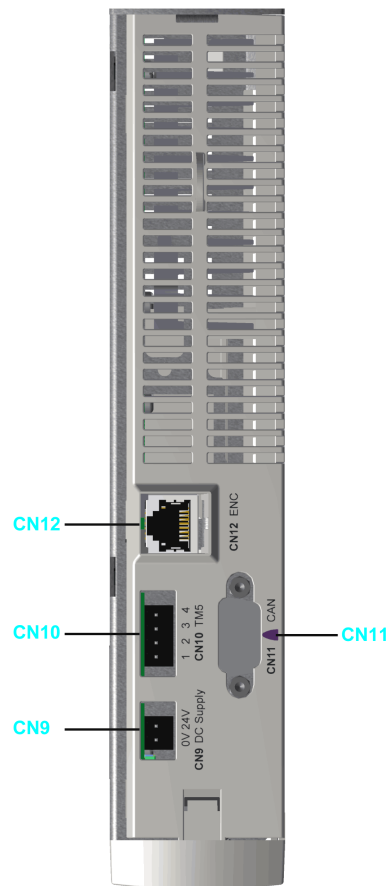

Conne- ction	Meaning	Connection cross- section [mm ²] / [AWG]	Tightening torque [Nm] / [lbf in]
CN9	24 Vdc	0.2...1.5 / 24...16	–
CN10	TM5 (not active)	–	–
CN11	CAN	–	0.4 Nm / 3.54 lbf in
CN12	Master encoder input	–	–

Bottom Side

Connection overview bottom side

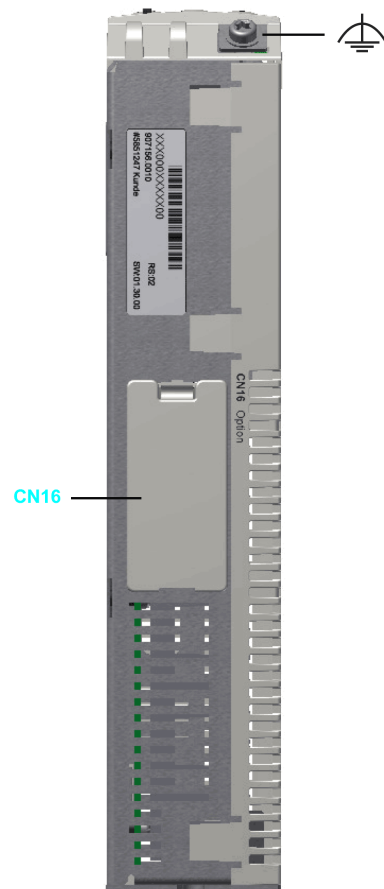

Connection	Meaning	Connection cross-section [mm ²] / [AWG]	Tightening torque [Nm] / [lbf in]
CN16	Option	–	–
	Ground (functional earth FE)	minimum 2.5 / minimum 13	1.4 / 12.39

Connection Details Controller

CN1 - Prog Port (USB mini-B)

NOTE: Prog port (USB mini-B) is not active.

CN2 - USB-A



Connection **CN2** USB - A

Pin	Designation	Meaning
1	VBUS / +5V	–
2	D- / Data-	Data line -

Pin	Designation	Meaning
3	D+ / Data+	Data line +
4	GND / Ground	–

CN3 - Ethernet

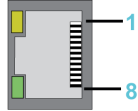

Connection **CN3**

Pin	Designation
1	D1 + (Tx+)
2	D1- (Tx-)
3	D2+ (Rx+)
4	D3+
5	D3-
6	D2- (Rx-)
7	D4+
8	D4-

CN3 LEDs

LED	Function	Off	On	Flashes
Green	State	No connection	Connection, no activity	Connection and activity
Yellow	Velocity	10 MBit	100 MBit / 1 GBit	–

CN4 - Serial Link (COM)

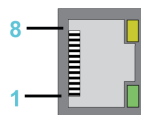

Connection **CN4**

Pin	Designation	Meaning
1	TxD	RS-232, transmit data
2	RxD	RS-232, receive data
3	CTS	RS-232, clear to send
4	D1 / B	Modbus D1, RS-485 B
5	D0 / A	Modbus D0, RS-485 A
6	RTS	RS-232, request to send
7	–	Reserved
8	0 V	Signal and power common

CN5 - Sercos

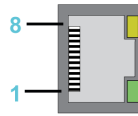

Connection **CN5**

Pin	Designation	Meaning
1	Tx+	Transmit data +
2	Tx-	Transmit data -
3	Rx+	Receive data +
4	–	Reserved
5	–	Reserved
6	Rx-	Receive data -
7	–	Reserved
8	–	Reserved

The Sercos LEDs indicate the state of the Sercos connection:

LED	On
Green	Activity
Yellow	Connection

CN6 - Sercos

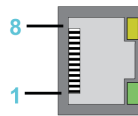

Connection **CN6**

Pin	Designation	Meaning
1	Tx+	Transmit data +
2	Tx-	Transmit data -
3	Rx+	Receive data +
4	–	Reserved
5	–	Reserved
6	Rx-	Receive data -
7	–	Reserved
8	–	Reserved

The Sercos LEDs indicate the state of the Sercos connection:

LED	On
Green	Activity
Yellow	Connection

CN7 - Digital Input

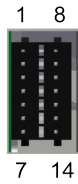

Connection **CN7**

Pin	Designation	Meaning
1	DI0	Digital inputs
2	DI1	
3	DI2	
4	DI3	
5	DI4	
6	DI5	
7	0V1	Reference potential DI0...DI11
8	DI6	Digital inputs
9	DI7	
10	DI8 (FI_0)	Fast digital inputs
11	DI9 (FI_1)	
12	DI10 (FI_2)	
13	DI11 (FI_3)	
14	0V2	Reference potential DI0...DI11

CN8 - Digital Output



Connection **CN8**

Pin	Designation	Meaning	Range
1	DQ0	–	–
2	DQ1	–	–
3	DQ2	–	–
4	DQ3	–	–
5	24V1	Supply voltage DQ0 - DQ7	-15% / +25%
6	0V3	Supply voltage DQ0 - DQ7	–
7	DQ4	–	–
8	DQ5	–	–
9	DQ6	–	–
10	DQ7	–	–

Pin	Designation	Meaning	Range
11	24V2	Supply voltage DQ0 - DQ7	-15% / +25%
12	0V4	Supply voltage DQ0 - DQ7	–

NOTE: When nothing is connected (or the connected device has a high impedance) to an LMC digital output, it measures ~9V for FALSE. If this causes an issue for the connected device, use an external pull-down resistor.

CN9 - Supply Voltage

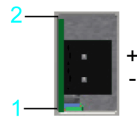

Connection **CN9**

Pin	Designation	Meaning	Range
1	0V	Supply voltage	–
2	+24V	Supply voltage	-15% / +25%

CN10 - TM5

NOTE: TM5 connection is not active.

CN11 - CAN

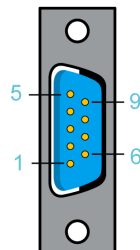

Connection **CN11**

Pin	Designation	Meaning
1	–	Reserved
2	CAN_L	Bus line (low)
3	CAN GND	–
4	–	Reserved
5	–	Reserved
6	CAN GND	–
7	CAN_H	Bus line (high)
8	–	Reserved
9	–	Reserved

NOTE: A connection of TM5 System via CAN bus and a CANopen interface module is not supported.

CN12 - Master Encoder Input (Hiperface)

The Hiperface connection consists of a standard, differential, digital connection (RS-485 = 2 wires), a differential, analog connection (sine- and cosine signal = 4 wires), and a mains connection to supply the encoder (+10V, GND = 2 wires).

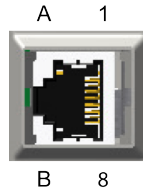

Connection **CN12** - Master encoder input (Hiperface)

Pin	Designation	Meaning
1	COS	Cosine track
2	REFCOS	Reference signal cosinus
3	SIN	Sinusoidal trace
4	RS485+	Parameter channel +
5	RS485-	Parameter channel -
6	REFSIN	Reference signal sine
7	-	Reserved
8	-	Reserved
A	Encoder supply (+)	-
B	GND	-

CN12 - Master Encoder Input (Incremental)

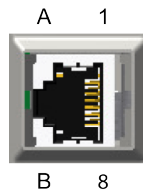

Connection **CN12** - Master encoder input (incremental)

Pin	Designation	Meaning
1	Trace B+	-
2	Trace B-	-
3	Trace A+	-
4	Trace N+	-
5	Trace N-	-
6	Trace A-	-
7	-	Reserved
8	-	Reserved
A	Encoder supply (+)	-
B	GND	-

Technical Data

Ambient Conditions

Ambient Conditions for Control Cabinet Devices:

Procedure	Parameter	Value	Basis
Operation	Class 3K3		IEC/EN 60721-3-3
	Degree of protection housing	IP 20	
	Pollution degree	2 (according to IEC 61131-2, UL508)	
	Ambient temperature	+5...+55 °C / +41...+131 °F	
	Condensation	No	
	Icing	No	
	Relative humidity	5%...95%	
	Installation height 0...2000 m (0...6561 ft) ⁽¹⁾	No derating	
	Installation height 2000...3000 m (6561...9842 ft) ⁽¹⁾	40 °C / 104 °F maximum ambient temperature	
	Class 3M4		
	Shock	100 m/s ²	
	Vibration	10 m/s ²	
Transport	Class 2K3		IEC/EN 60721-3-2
	Ambient temperature	-25...+70 °C / -13...+158 °F	
	Condensation	No	
	Icing	No	
	Relative humidity	5%...95%	
	Maximum altitude of transport	10000 m (32808 ft)	
	Class 2M2		
	Shock	300 m/s ²	
	Vibration	15 m/s ²	
Long-term storage in transport packaging	Class 1K4		IEC/EN 60721-3-1
	Ambient temperature	-25...+55 °C / -13...+131 °F	
	Condensation	No	
	Icing	No	
	Relative humidity	5%...95%	
⁽¹⁾ The installation height is defined as height above sea level.			

Standards and Regulations

Overview

Declarations and certifications

CE	EMC Directive 2014/30/EU • EN 61131-2:2007 (Zone B)
cULus	UL 508: Industrial Control Equipment
	Process Control Equipment • CSA-C22.2 No. 142
China RoHS	Marking for the Restricted Use of Hazardous Substances in Electronic and Electrical Products • SJ/T 11364

Mechanical and Electrical Data

Technical Data PacDrive LMC Eco

Category	Parameter	Value					
		LMC 100C	LMC 101C	LMC 106C	LMC 201C	LMC 212C	LMC 216C
Product configuration	Type code						
Configuration	Processor	CPU Intel Atom 1.66 GHz 512 KB L2 cache					
	Random access memory ⁽¹⁾	≥512 MB RAM					
	NV RAM	128 KB					
	Battery for NVRAM and RTC	Yes (internal, data retention > 10 years)					
	Memory card (SD card)	At least 512 MB (accessible from the outside)					
	Control buttons	3					
	On/off button	No					
	Reset button	No					
	Cooling	Passive					
	Real Time Clock (RTC)	Yes (deviation maximum ± 1 s in 24 h)					
	Maximum number of drives (servo axes)	0	4	6	8	12	16
	Operating system	Real-time operating system	VxWorks and SEA Automation kernel				
Diagnostics	Watchdog	Yes (configurable output)					
	Diagnostic display	Liquid Crystal Display (LCD) 128 x 64 (with background lighting)					
	Status LED's	State / CAN / TM5 / S3 / PRG					
	Integrated data logger for diagnostic messages	Yes					
	Integrated trace recorder (software oscilloscope)	Yes					
Bus connections	Integrated automation bus	Sercos (master)					
	Integrated additional fieldbus	CAN (master/slave)					
	TM5 bus	Not active					
Communication / interfaces	Serial interfaces	1 x COM: RS-232 / RS-485 (RJ45)					
	Modbus	Yes (RJ45)					
	Network connection	1 x Ethernet 10/100/1000 Base-T (RJ45)					
	USB connection	1 x USB-A (host for storage medium)					
		1 x USB mini-B, not active					
	Optional slot for another fieldbus	1 x communication module realtime Ethernet 10/100 Base-T or					

Category	Parameter	Value					
		LMC 100C	LMC 101C	LMC 106C	LMC 201C	LMC 212C	LMC 216C
Product configuration	Type code						
		1 x communication module PROFIBUS DP					
Programming-languages IEC 61131-3	–	Continuous function chart (CFC)					
		Function block diagram (FBD)					
		Instruction list (IL)					
		Structured text (ST)					
		Ladder diagram (LD)					
		Sequential function chart (SFC)					
Touchprobe + fast inputs (Interrupt)	Number	4					
	Input characteristic	According to IEC61131-2 type 1					
	U _{IN} low voltage	-3...5 Vdc (< 10 V / 1,1 mA)					
	U _{IN} high voltage	15...30 Vdc (> 10,5 V / 1,5 mA)					
	Input voltage	24 Vdc (+25%)					
	Input current	4 mA @ 24 V					
	Hardware input filter	100 µs					
	Input filter DI8...DI11	100 µs - 4.29 s					
	Touchprobe resolution DI8 to DI11	10 µs at a Sercos cycle time of 1, 2, 4 ms					
Digital inputs	Number	8					
	Input characteristic	According to IEC61131-2 type 1					
	U _{IN} low voltage	-3...5 Vdc (< 10 V / 1,1 mA)					
	U _{IN} high voltage	15...30 Vdc (> 10,5 V / 1,5 mA)					
	Input voltage	24 Vdc (+25%)					
	Input current	4 mA @ 24 V					
	Hardware input filter	100 µs					
	Input filter DI0...DI7	100 µs - 4.29 s					
Digital outputs	Number	8					
	Output characteristic	According to IEC61131-2 type1					
	Output voltage	(+UL-3 V) < U _{OUT} < +UL					
	Rated current	I _e = 500 mA rated per output and 2 A maximum for all outputs at once (for example, 8 outputs with 250 mA)					
	Inrush current	I _{emax} < 2 A for 1 s					
	Leakage current with 0 signal	≤ 0.5 mA					
	Transmission time	<100 µs					
	Short circuit protection	Yes					
	Open circuit detection	Yes					
	Openload error detection	R _{load} > 150 kΩ					
	Overload error detection	U _{DQ+24V} - U _{DQx} > 4.0 V					
	Master encoder input	Hiperface®	Voltage output: 10 V / 200 mA Analog channel 0.9 V...1.1 V _{pp} / 2.2...2.8 V _{offset} (maximum 250 KHz) Parameter channel Hiperface RS-485: Cable length ≤50 m (164 ft)				
INC		Voltage output: 5 V / 300 mA Level according to RS422 (maximum 1 MHz)					

Category	Parameter	Value					
Product configuration	Type code	LMC 100C	LMC 101C	LMC 106C	LMC 201C	LMC 212C	LMC 216C
		Cable length ≤50 m (164 ft)					
Power supply	Power consumption of power supply	20.4 Vdc...30 Vdc maximum 27 W					
	Inrush current	maximum 10 A					
Dimensions	Dimensions of housing	DxWxH (mm): 222 x 44 x 270					
Weight	Weight (with accessory and carton)	1.6 kg (2.2 kg) / 3.52 lbs (4.9 lbs)					
(1) If you replace devices, verify that the replaced devices have at least the same hardware revision or later.							

Dimensions

Dimensions

Dimensions of the PacDrive LMC Eco:

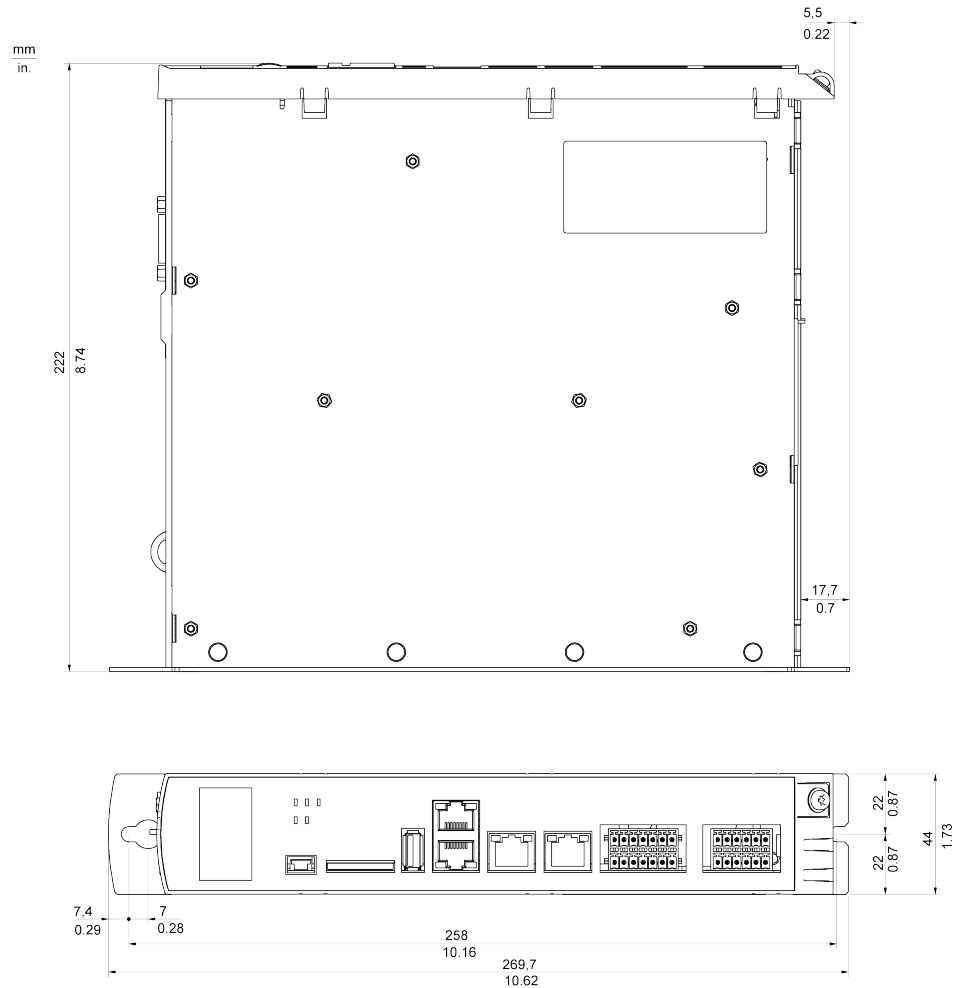

Optional Modules

Fieldbus Combinations

General

The PacDrive LMC Eco has a CAN chip onboard that can operated with an independent field bus protocol. Another field bus can be used through the options module slot of the PacDrive LMC Eco. It can be equipped with the communication module PROFIBUS DP or Realtime Ethernet.

The following bus combinations are possible:

Combination	Onboard	Communication Module	
	LMC x01C	PROFIBUS DP	Realtime Ethernet
1	CAN	PROFIBUS	–
2	CAN	–	PROFINET
3	CAN	–	EtherNet/IP
4	CAN	–	EtherCAT

This way, the PacDrive LMC ECO can be operated with the following fieldbus combinations:

- Combination 1: A CAN on board with another PROFIBUS
- Combinations 2 - 4: A CAN on board with another Ethernet field bus (PROFINET, EtherNet/IP or EtherCAT)

Communication Module Realtime Ethernet

Overview

General Information

The communication module Realtime Ethernet is an optional module that provides a PROFINET, EtherNet/IP, EtherCAT, C2C slave or additional standard Ethernet interface.

Communication module Realtime Ethernet - connections

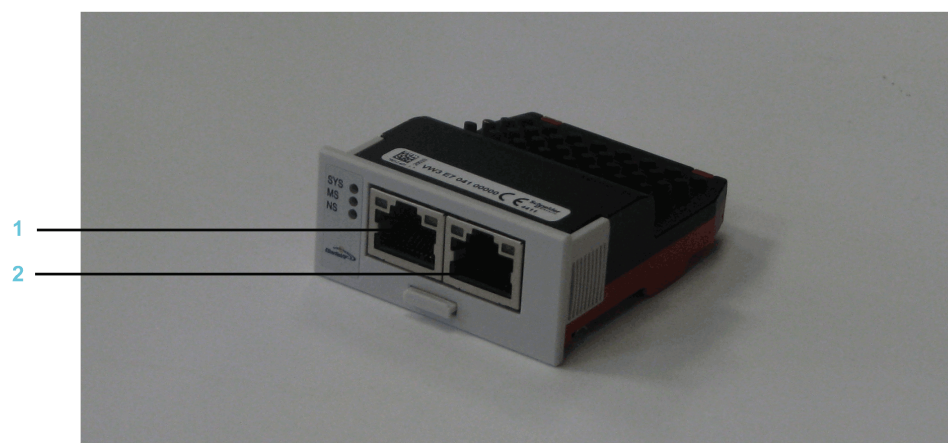

- 1 Ethernet channel 0
- 2 Ethernet channel 1

After installing the optional module, the controller will automatically detect the module. Then configure it by using the PLC configuration in EcoStruxure Machine Expert Logic Builder.

LED Labels of the Realtime Ethernet Communication Module

With the Realtime Ethernet communication modules, it is possible to use different protocols. The meaning of the LEDs depends on the protocol selected.

The three LED labels for the Realtime Ethernet communication module are enclosed in the package.

NOTICE
INOPERABLE EQUIPMENT
Do not touch the contacts when unpacking or installing the communication module.
Failure to follow these instructions can result in equipment damage.

Affix the LED label which corresponds to the protocol selected:

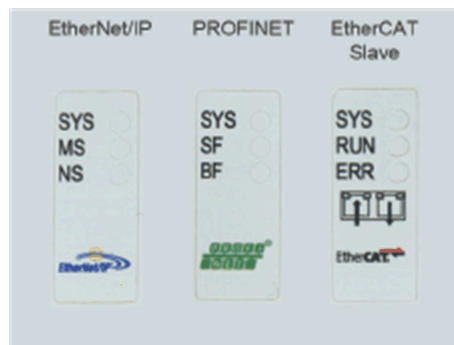

NOTE: There is no label for the C2C slave protocol nor the additional standard Ethernet.

Mechanical Installation

Consideration

NOTICE
INOPERABLE EQUIPMENT
Do not touch the contacts when unpacking or installing the optional module.
Failure to follow these instructions can result in equipment damage.

How to Open the Controller

Step	Action
1	Remove the cover of input CN16 option at the bottom side of the housing. To do this, push the locking of the cover backward. Result: The cover folds down.
2	Pull the cover to the front and remove it.

How to Install the Optional Module

NOTICE

INCORRECT INSERTION OF OPTIONAL MODULE

- Do not insert the optional module when the controller is under power.
- Verify that the springs at the bottom side of the module are located at the printed circuit board side when you insert the module into the slot.

Failure to follow these instructions can result in equipment damage.

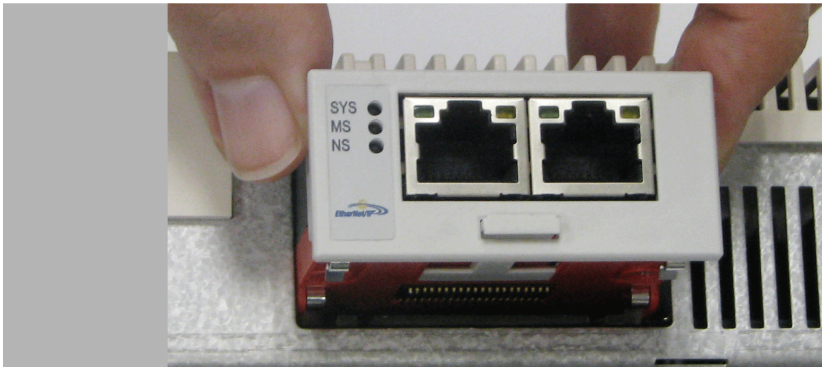
Step	Action
1	Ensure that the controller is switched off.
2	<p>Insert the module into the slot and push against the printed circuit board until both front springs at the bottom side lower into the openings on the printed circuit board.</p>  <p>Result: The module rests on the lower edge of the slot.</p>
3	<p>Slightly apply pressure and push the module further inside until it is flush at the edge.</p> <p>Result: The springs at the bottom side reach into the openings of the printed circuit board.</p>

NOTE: Ensure that the module is flush at the edge.

How to Remove the Optional Module

NOTICE

INOPERABLE EQUIPMENT

Do not remove the optional module when the controller is under power.

Failure to follow these instructions can result in equipment damage.

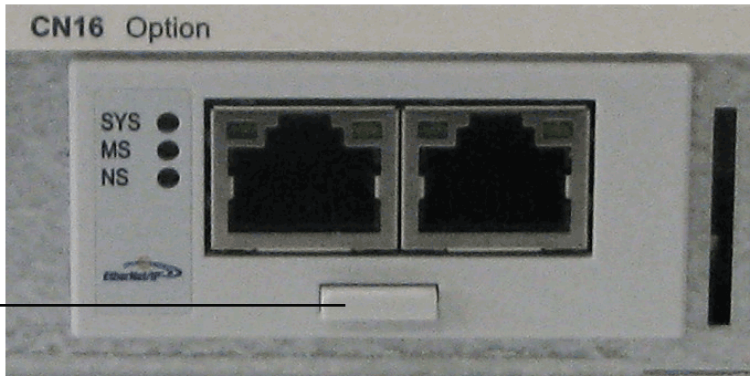
Step	Action
1	Take the protruding part of the handle of the flap and pull the handle out the optional module.  1 Flap handle
2	Pull at the strap handle and pull the optional module out of the slot until its latching releases.
3	Completely remove the optional module from the slot.
4	Push the flap handle back into the module.
5	Insert the protective cover in the resulting opening for the optional module and push it upward until it latches.
6	Push the cover locking mechanism to the front until it latches.

Electrical Connections

Connection Details Communication Module Realtime Ethernet

NOTE: The Realtime Ethernet communication module can be programmed differently. Depending on the protocol selected, you need to affix a label to the LEDs. Refer to LED Labels of the Realtime Ethernet Communication Module, page 76.

Connection details Realtime Ethernet

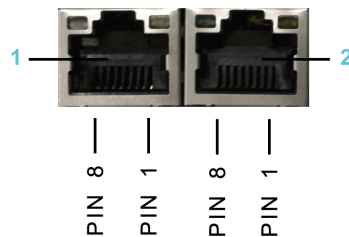

1 Ethernet channel 0

2 Ethernet channel 1

Ethernet outlet

Pin	Designation	Meaning
1	Tx+	Transmit data +
2	Tx-	Transmit data -
3	Rx+	Receive data +
4	TERM	-
5	TERM	
6	Rx-	Receive data -

Pin	Designation	Meaning
7	TERM	–
8	TERM	–

LED Description PROFINET

LEDs PROFINET

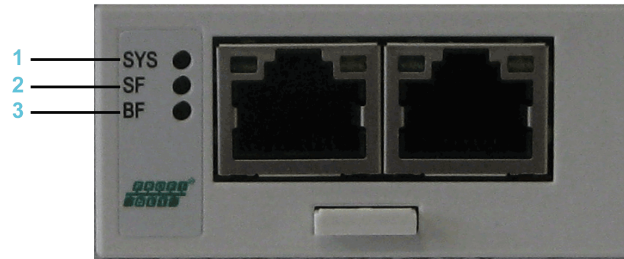

1 SYS = System LED

2 SF = System error

3 BF = Bus error

System LED

LED	Color	State	Meaning
SYS	Duo LED yellow/green		
	Yellow	Static	Bootloader netX (= roomloader) is waiting for second stage bootloader.
	Green/yellow	Flashing green/yellow	Second stage bootloader is waiting for firmware.
	Green	On	Operating system running.
	Off	Off	No power supply.

LEDs PROFINET IO RT controller

LED	Color	State	Meaning
SF	Duo LED red/green		
	Red	On	(Together with BF red = on:) No valid master license.
	Red	Flashing cyclic at 2 Hz	System error detected: Invalid configuration.
	Off	Off	Normal operation.
BF	Duo LED red/green		
	Red	On	No connection: No Link. Or (together with SF red = on) No valid master license.
	Red	Flashing cyclic at 2 Hz	Configuration error detected: not all configured I/O devices are connected.
	Off	Off	Normal operation.
LINK/RJ45 Ch0 & Ch1	LED green		
	Green	On	A connection to Ethernet exists.
	Off	Off	The device has no connection to Ethernet.
RX/TX/RJ45 Ch0 & Ch1	LED yellow		
	Yellow	Flashes	The device sends/receives Ethernet frames.

LEDs PROFINET IO RT device

LED	Color	State	Meaning
SF	Duo LED red/green		
	Red	On	Watchdog timeout, channel, generic or extended diagnostic present; system error detected.
	Red	Flashing cyclic at 2 Hz (for 3 s)	DCP signal service is initiated via the bus.
	Off	Off	Normal operation.
BF	Duo LED red/green		
	Red	On	No configuration; or low speed physical link; or no physical link.
	Red	Flashing cyclic at 2 Hz	No data exchange.
	Off	Off	Normal operation.
LINK/RJ45 Ch0 & Ch1	LED green		
	Green	On	A connection to Ethernet exists.
	Off	Off	The device has no connection to Ethernet.
RX/TX/RJ45 Ch0 & Ch1	LED yellow		
	Yellow	Flashes	The device sends/receives Ethernet frames.

LED Description EtherNet/IP

LEDs EtherNet/IP

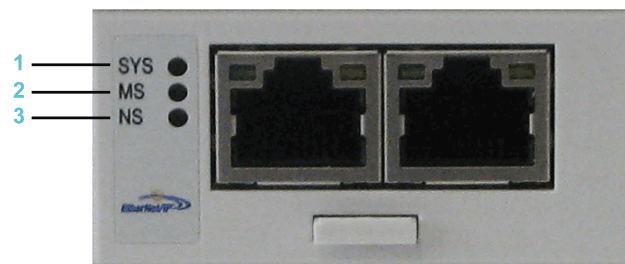

1 SYS= System LED

2 MS= Module Status

3 NS= Network Status

System LED

LED	Color	State	Meaning
SYS	Duo LED yellow/green		
	Yellow	Static	Bootloader netX (= roomloader) is waiting for second stage bootloader.
	Green/yellow	Flashing green/yellow	Second stage bootloader is waiting for firmware.
	Green	On	Operating system running.
	Off	Off	No power supply.

LEDs EtherNet/IP Scanner (master)

LED	Color	State	Meaning
MS	Duo LED red/green		
	Green	On	Device operational: If the device is operating correctly, the module status indicator is steady green.
	Green	Flashes	Standby: If the device has not been configured, the module status indicator is flashing green.
	Red	On	Major error detected: If the device has detected a non-recoverable error, the module status indicator is steady red.
	Red	Flashes	Minor error detected: If the device has detected a recoverable error, the module status indicator is flashing red. NOTE: An incorrect or inconsistent configuration is a minor error.
	Red/green	Flashes	Self-test: While the device is performing its power-up testing, the module status indicator is flashing green/red.
	Off	Off	No power: If no power is supplied to the device, the module status indicator is steady off.
NS	Duo LED red/green		
	Green	On	Connected: If the device has at least one established connection (even to the Message Router), the network status indicator is steady green.
	Green	Flashes	No connections: The device has no established connections, but has obtained an IP address. In this case, the network status indicator flashes green.
	Red	On	Duplicate IP: If the device has detected that its IP address is already in use, the network status indicator is steady red.
	Red	Flashes	Connection timeout: If one or more connections in which this device is the target has timed out, the network status indicator is flashing red. This is left only if all timed out connections are re-established or if the device is reset.
	Red/green	Flashes	Self-test: While the device is performing its power-up testing, the network status indicator is flashing green/red.
	Off	Off	Not powered, no IP address: If the device does not have an IP address (or is powered off), the network status indicator is off.
LINK/RJ45 Ch0 & Ch1	LED green		
	Green	On	A connection to Ethernet exists.
	Off	Off	The device has no connection to Ethernet.
ACT/RJ45 Ch0 & Ch1	LED yellow		
	Yellow	Flashes	The device sends/receives Ethernet frames.

LEDs EtherNet/IP Adapter (slave)

LED	Color	State	Meaning
MS	Duo LED red/green		
	Green	On	Device operational: If the device is operating correctly, the module status indicator is steady green.
	Green	Flashes	Standby: If the device has not been configured, the module status indicator is flashing green.
	Red	On	Major error detected: If the device has detected a non-recoverable error, the module status indicator is steady red.
	Red	Flashes	Minor error detected: If the device has detected a recoverable error, the module status indicator is flashing red. NOTE: An incorrect or inconsistent configuration is a minor error.
	Red/green	Flashes	Self-test: While the device is performing its power-up testing, the module status indicator is flashing green/red.
	Off	Off	No power: If no power is supplied to the device, the module status indicator is off.
NS	Duo LED red/green		
	Green	On	Connected: If the device has at least one established connection (even to the Message Router), the network status indicator is steady green.
	Green	Flashes	No connections: If the device has no established connections, but has obtained an IP address, the network status indicator is flashing green.
	Red	On	Duplicate IP: If the device has detected that its IP address is already in use, the network status indicator is steady red.
	Red	Flashes	Connection timeout: If one or more connections in which this device is the target has timed out, the network status indicator is flashing red. This is left only if all timed out connections are re-established or if the device is reset.
	Red/green	Flashes	Self-test: While the device is performing its power-up testing, the network status indicator is flashing green/red.
	Off	Off	Not powered, no IP address: If the device does not have an IP address (or is powered off), the network status indicator is off.
LINK/RJ45 Ch0 & Ch1	LED green		
	Green	On	A connection to Ethernet exists.
	Off	Off	The device has no connection to Ethernet.
ACT/RJ45 Ch0 & Ch1	LED yellow		
	Yellow	Flashes	The device sends/receives Ethernet frames.

LED Description EtherCat

LEDs EtherCAT

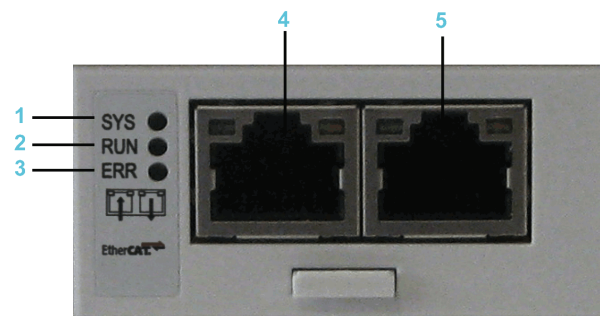

1 SYS= System LED

2 RUN= Run

3 ERR= Error

4 Ethernet channel 0 - input port*

5 Ethernet channel 0 - output port*

* Input port and output port are predetermined by firmware and are not configurable.

System LED

LED	Color	State	Meaning
SYS	Duo LED yellow/green		
	Yellow	Static	Bootloader netX (= roomloader) is waiting for second stage bootloader.
	Green/yellow	Flashing green/yellow	Second stage bootloader is waiting for firmware.
	Green	On	Operating system running.
	Off	Off	Power supply of the device is missing.

LEDs EtherCAT-Slave

LED	Color	State	Meaning
RUN	Duo LED red/green		
	Green	On	Operational: The device is in the OPERATIONAL state.
	Green	Flashing cyclic with 2.5 Hz ⁽¹⁾	Pre-operational: The device is in the PRE_OPERATIONAL state as defined for EtherCAT.
	Green	Single flash ⁽²⁾	Safe-operational: The device is in the SAFE-OPERATIONAL state as defined for EtherCAT.
	Off	Off	Init: The device is in the initialization state.
ERR	Duo LED red/green		
	Red	Flashing cyclic with 2.5 Hz ⁽¹⁾	Invalid configuration: General configuration error detected. Possible cause: A status change specified by the master is not possible due to register- or object settings.
	Red	Single flash ⁽²⁾	Local error: The slave device application changed the EtherCAT status itself. Possible cause 1: A host watchdog timeout occurred. Possible cause 2: Synchronization error, the device automatically switches to SAFE-OPERATIONAL as defined for EtherCAT.
	Red	Double flash ⁽³⁾	Process data watchdog timeout: A process data watchdog timeout occurred. Possible cause: Sync-Manager watchdog timeout.
	Off	Off	No error: The EtherCAT communication of the device is in operation.
LINK/RJ45 Ch0 & Ch1	LED green		
	Green	On	A connection to Ethernet exists.
	Green	Flashing cyclic with 2.5 Hz ⁽¹⁾	The device sends/receives Ethernet frames.
	Off	Off	The device has no connection to Ethernet.
RJ45 Ch0 & Ch1	LED yellow		
	–	–	This LED is not used.
<p>⁽¹⁾ The LED is switched On (for 200 ms) and Off (for 200 ms) with a frequency of 2.5 Hz.</p> <p>⁽²⁾ The LED shows a short flash (200 ms) followed by a long Off phase (1000 ms).</p> <p>⁽³⁾ The LED shows a sequence of two short flashes (each 200 ms), interrupted by a short Off phase (200 ms). The sequence is completed with a long Off phase (1000 ms).</p>			

LEDs EtherCAT-Master

LED	Color	State	Meaning
RUN	Duo LED red/green		
	Green	On	Operational: The device is in the OPERATIONAL state.
	Green	Flashing cyclic with 2.5 Hz ⁽¹⁾	Pre-operational: The device is in the PRE_OPERATIONAL state as defined for EtherCAT.
	Green	Flickering (10 Hz) ⁽²⁾	The device is not configured.
	Green	Single flash ⁽³⁾	Safe-operational: The device is in the SAFE-OPERATIONAL state as defined for EtherCAT.
	Off	Off	Init: The device is in the initialization state.
ERR	Duo LED red/green		
	Red	Flashing cyclic with 2.5 Hz ⁽¹⁾	Invalid configuration. General configuration error detected.
	Red	Single flash ⁽³⁾	Bus Sync threshold error detected.
	Red	Double flash ⁽⁴⁾	Internal stop of the bus cycle
	Red	Triple flash ⁽⁵⁾	DPM watchdog has expired.
	Red	Quadruple flash ⁽⁶⁾	No master license present in the device.
	Red	Single flickering ⁽⁷⁾	Channel Init was expected at the master. Transient state that may not be visible.
	Red	Double flickering ⁽⁸⁾	Slave is missing. Unconfigured slave No matching mandatory slave list. No bus connected.
	Red	Flickering (10 Hz) ⁽²⁾	Boot-up was stopped due to detected errors.
	Off	Off	No errors detected: The EtherCAT communication of the device is in operation.
LINK Ch0	LED Green		
	Green	On	A connection to Ethernet exists.
	Green	Flickering (load dependent) ⁽⁹⁾	The device sends/receives Ethernet frames.
	Green	Off	The device has no connection to the Ethernet.
ACT Ch0	LED Yellow		
	Off	Off	The LED is not used.
<p>⁽¹⁾ The LED is switched On (for 200 ms), followed by Off (for 200 ms) with a frequency of 2.5 Hz.</p> <p>⁽²⁾ The LED is switched On (for 50 ms) and Off (for 50 ms) with a frequency of 10 Hz.</p> <p>⁽³⁾ The LED shows one short flash (200 ms) followed by a long Off phase (1,000 ms).</p> <p>⁽⁴⁾ The LED shows a sequence of two short flashes (each 200 ms), interrupted by a short Off phase (200 ms). The sequence is completed with a long Off phase (1000 ms).</p> <p>⁽⁵⁾ The LED shows a sequence of three short flashes (each 200 ms), interrupted by a short Off phase (200 ms). The sequence is completed with a long Off phase (1,000 ms).</p> <p>⁽⁶⁾ The LED shows a sequence of four flashes (each 200 ms), interrupted by a short Off phase (200 ms). The sequence is completed with a long Off phase (1,000 ms).</p> <p>⁽⁷⁾ The LED is switched On for 50 ms, followed by Off for 500 ms.</p> <p>⁽⁸⁾ The LED is switched On / Off / On for 50 ms, followed by Off for 500 ms.</p> <p>⁽⁹⁾ The LED turns On (for 50 ms) followed by Off (for 50 ms) with a frequency of approximately 10 Hz to indicate high Ethernet activity. The LED turns On and Off in irregular intervals to indicate low Ethernet activity.</p>			

LED Description C2C Slave

LED	Color	State	Meaning
LINK/RJ45 Ch0 & Ch1	LED green		
	Green	On	A connection to Ethernet exists.
	Green	Flashing cyclic	The device sends/receives Ethernet frames.
	Off	Off	The device has no connection to Ethernet.
RJ45 Ch0 & Ch1	LED yellow		
	–	–	This LED is not used.

LED Description Additional Ethernet

LED	Color	State	Meaning
LINK/RJ45 Ch0 & Ch1	LED green		
	Green	On	A connection to Ethernet exists.
	Off	Off	The device has no connection to Ethernet.
RX/TX/RJ45 Ch0 & Ch1	LED yellow		
	yellow	Flashes	The device send/receives Ethernet frames.

Communication Module PROFIBUS DP

Overview

General Information

The communication module PROFIBUS DP provides a PROFIBUS interface.

Communication module PROFIBUS DP - connection

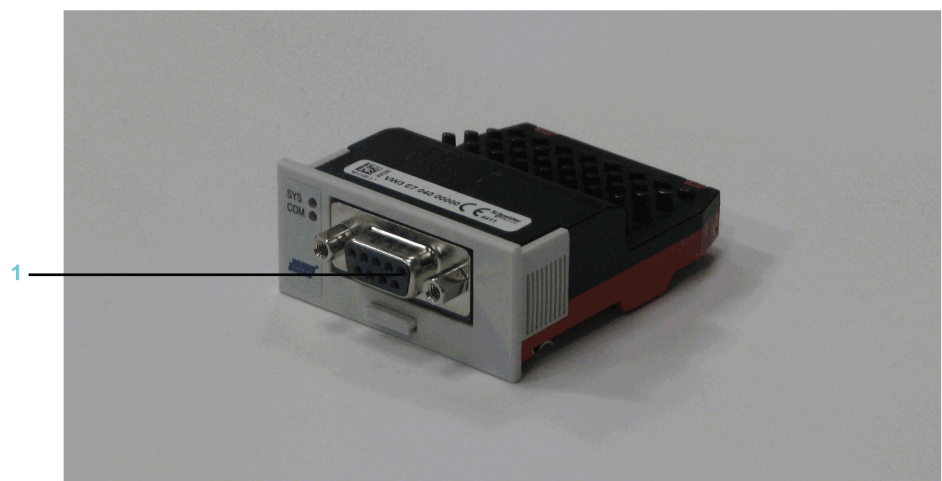

1 PROFIBUS DP connection

After installing the optional module, the controller will automatically detect the module. Then configure it by using the PLC configuration in EcoStruxure Machine Expert Logic Builder.

Mechanical Installation

Consideration

NOTICE
<p>INOPERABLE EQUIPMENT</p> <p>Do not touch the contacts when unpacking or installing the optional module.</p> <p>Failure to follow these instructions can result in equipment damage.</p>

How to Open the Controller

Step	Action
1	<p>Remove the cover of input CN16 option at the bottom side of the housing. To do this, push the locking of the cover backward.</p> <p>Result: The cover folds down.</p>
2	<p>Pull the cover to the front and remove it.</p>

How to Install the Optional Module

NOTICE
<p>INCORRECT INSERTION OF OPTIONAL MODULE</p> <ul style="list-style-type: none"> Do not insert the optional module when the controller is under power. Verify that the springs at the bottom side of the module are located at the printed circuit board side when you insert the module into the slot. <p>Failure to follow these instructions can result in equipment damage.</p>

Step	Action
1	<p>Ensure that the controller is switched off.</p>
2	<p>Insert the module into the slot and push against the printed circuit board until both front springs at the bottom side lower into the openings on the printed circuit board.</p> <div data-bbox="604 1424 1437 1774" data-label="Image"> </div> <p>Result: The module rests on the lower edge of the slot.</p>
3	<p>Slightly apply pressure and push the module further inside until it is flush at the edge.</p> <p>Result: The springs at the bottom side reach into the openings of the printed circuit board.</p>

NOTE: Ensure that the module is flush at the edge.

How to Remove the Optional Module

NOTICE
INOPERABLE EQUIPMENT
Do not remove the optional module when the controller is under power.
Failure to follow these instructions can result in equipment damage.

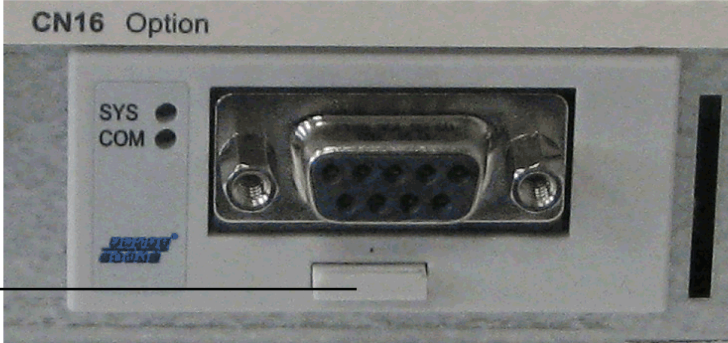
Step	Action
1	Take the protruding part of the handle of the flap and pull the handle out the optional module.  1 Flap handle
2	Pull at the strap handle and pull the optional module out of the slot until its latching releases.
3	Completely remove the optional module from the slot.
4	Push the flap handle back into the module.
5	Insert the protective cover in the resulting opening for the optional module and push it upward until it latches.
6	Push the cover locking mechanism to the front until it latches.

Electrical Connections

Connection Details Communication Module PROFIBUS DP

Connection details PROFIBUS DP

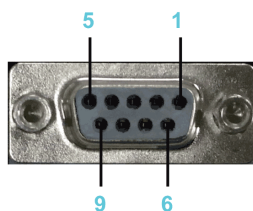

Connection assignment PROFIBUS DP

Pin	Designation	Meaning
1	–	Reserved
2	–	Reserved
3	Rx/Tx+(PB-B)	PROFIBUS DP - data line B (positive)
4	RTS	Return to send line for line control
5	PB-GND	Ground for PROFIBUS DP
6	PB-5V	5 V power line for PROFIBUS DP

Pin	Designation	Meaning
7	-	Reserved
8	Rx/Tx-(PB-A)	PROFIBUS DP - data line A (negative)
9	-	Reserved

LED Description PROFIBUS DP

LEDs PROFIBUS DP

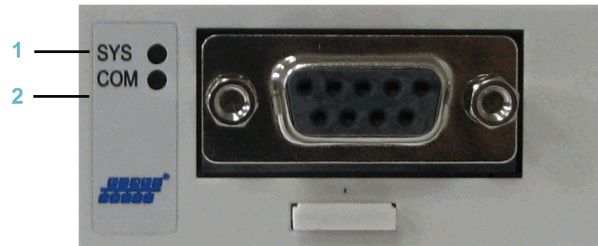

1 SYS = System LED

2 COM = Communication

System LED

LED	Color	State	Meaning
SYS	Duo LED yellow/green		
	Yellow	Static	Bootloader netX (= roomloader) is waiting for second stage bootloader.
	Green/yellow	Flashing green/yellow	Second stage bootloader is waiting for firmware.
	Green	On	Operating system running.
	Off	Off	No power supply.

PROFIBUS DP master - communication LED

LED	Color	State	Meaning
COM	Duo LED red/green		
	Green	Flashing acyclic	No configuration or stack error detected.
	Green	Flashing cyclic	PROFIBUS is configured, but bus communication is not yet released from the application.
	Green	On	Communication to all slaves is established.
	Red	Flashing cyclic	Communication to at least one slave is disconnected.
	Red	On	Communication to one/all slaves is disconnected.

PROFIBUS DP slave - communication LED

LED	Color	State	Meaning
COM	Duo LED red/green		
	Green	On	RUN, cyclic communication.
	Red	Flashing cyclic	STOP, no communication, connection error detected.
	Red	Flashing acyclic	Not configured.

Appendices

What's in This Part

Disposal	92
----------------	----

Disposal

What's in This Chapter

Disposal	92
----------------	----

Disposal

Information on the Disposal of Schneider Electric Products

NOTE: The components consist of different materials which can be recycled and must be disposed of separately.

Step	Action
1	Dispose of the packaging in accordance with the relevant national regulations.
2	Dispose of the packaging at the disposal sites provided for this purpose.
3	Dispose of controller in accordance with the applicable national regulations.

Index

B

bending cycles 31

C

certifications 71
 climatic 29
 condensate 29
 cooling units 29

D

daisy chain connector box 20
 daisy chain wiring 20
 degree of protection 28
 domestic appliances 15

F

floating systems 15

H

hazardous, explosive atmospheres 15

I

intended use 6
 IP 28

L

life support system 15

M

machine grounding 30
 mechanical 29
 minimum bending radius 31
 minimum cross sections 30
 mobile systems 15

P

portable systems 15
 product related information 10

Q

qualification of personnel 5

T

temperature limit 29

U

underground 15

W

wiring 30

Schneider Electric
35 rue Joseph Monier
92500 Rueil Malmaison
France

+ 33 (0) 1 41 29 70 00

www.se.com

As standards, specifications, and design change from time to time, please ask for confirmation of the information given in this publication.

© 2025 Schneider Electric. All rights reserved.

EIO0000001501.10