

Modicon X80

BMXERT1604T/H Time Stamp Module

User Manual

Original instructions

09/2020

The information provided in this documentation contains general descriptions and/or technical characteristics of the performance of the products contained herein. This documentation is not intended as a substitute for and is not to be used for determining suitability or reliability of these products for specific user applications. It is the duty of any such user or integrator to perform the appropriate and complete risk analysis, evaluation and testing of the products with respect to the relevant specific application or use thereof. Neither Schneider Electric nor any of its affiliates or subsidiaries shall be responsible or liable for misuse of the information contained herein. If you have any suggestions for improvements or amendments or have found errors in this publication, please notify us.

You agree not to reproduce, other than for your own personal, noncommercial use, all or part of this document on any medium whatsoever without permission of Schneider Electric, given in writing. You also agree not to establish any hypertext links to this document or its content. Schneider Electric does not grant any right or license for the personal and noncommercial use of the document or its content, except for a non-exclusive license to consult it on an "as is" basis, at your own risk. All other rights are reserved.

All pertinent state, regional, and local safety regulations must be observed when installing and using this product. For reasons of safety and to help ensure compliance with documented system data, only the manufacturer should perform repairs to components.

When devices are used for applications with technical safety requirements, the relevant instructions must be followed.

Failure to use Schneider Electric software or approved software with our hardware products may result in injury, harm, or improper operating results.

Failure to observe this information can result in injury or equipment damage.

© 2020 Schneider Electric. All rights reserved.

Table of Contents



	Safety Information	5
	About the Book	9
Part I	Functional Overview	11
Chapter 1	Introduction	13
	Module Overview	13
Chapter 2	User Functions	15
2.1	Introduction	16
	Main Functions	16
2.2	Discrete Input	18
	Enable and Disable Discrete Inputs	19
	Multi-voltage and Supply Monitor Sub-functions	20
	Debounce Filter	21
2.3	Time Stamping Sub-functions	23
	Edge Detection	24
	Dechatter Filter	25
	Time Synchronization	27
	Event Storage	31
	Behavior Mode	36
	EFB for BMXERT1604T/H Module	40
2.4	Counter Function	41
	Counter Function	41
Chapter 3	Applications	43
	Application Areas	44
	Typical Applications	45
Part II	Physical Implementation	51
Chapter 4	Module Description	53
	Overview	54
	Dimensions of X80 BMXERT1604T Time Stamping Module	56
	28-Pin Terminal Blocks: BMX FTB 28•0	57
	Standards and Certifications	61
	Field Wiring	62
	Diagnosis	65
	Technical Data	66
	Compatibility and Limitations	70

Chapter 5	Guidelines for the Physical Installation	75
	Installing the BMXERT1604T/H Time Stamping Module	76
	Fitting 28-pin Terminal Blocks	78
	Shielding Connection Kit	82
Part III	BMXERT1604T/H Software Implementation	85
Chapter 6	Configuration of BMXERT1604T/H Module	87
6.1	Using BMXERT1604T/H in Control Expert	88
	Inserting BMXERT1604T/H in the Rack	88
6.2	User Screen for BMXERT1604T/H Module	90
	User Screen Overview	91
	Module Configuration	93
	User Screen in Online Mode	96
6.3	Configuration Parameters for Channels	103
	Main Function Configuration	104
	Configuration for Group 0 Time Stamping	106
	Configuration for Group 1, 2, 3 Time Stamping	109
	Configuration for Group 1, 2, 3 Discrete Input Without Time Stamping	111
	Configuring Group 1, 2, 3 for Counters	113
6.4	Configuration in Project Settings	115
	Time and Mode Setting	115
Chapter 7	IODDTs and Languages Objects for the BMXERT1604T/H	119
	Introduction of Language Objects	120
	IODDTs	121
	Details of the Language Objects of the IODDT of Type T_GEN_MOD	124
	Language Objects for Channels	125
Chapter 8	Device DDT for the BMXERT1604T/H Module	129
	BMXERT1604T/H Device DDT	130
	MOD_FLT Byte Description	132
Chapter 9	Firmware Update	133
	Firmware Update with Automation Device Maintenance	134
	Module Firmware Update with Unity Loader	135
Index	137

Safety Information



Important Information

NOTICE

Read these instructions carefully, and look at the equipment to become familiar with the device before trying to install, operate, service, or maintain it. The following special messages may appear throughout this documentation or on the equipment to warn of potential hazards or to call attention to information that clarifies or simplifies a procedure.



The addition of this symbol to a “Danger” or “Warning” safety label indicates that an electrical hazard exists which will result in personal injury if the instructions are not followed.



This is the safety alert symbol. It is used to alert you to potential personal injury hazards. Obey all safety messages that follow this symbol to avoid possible injury or death.

DANGER

DANGER indicates a hazardous situation which, if not avoided, **will result in death** or serious injury.

WARNING

WARNING indicates a hazardous situation which, if not avoided, **could result in death** or serious injury.

CAUTION

CAUTION indicates a hazardous situation which, if not avoided, **could result** in minor or moderate injury.

NOTICE

NOTICE is used to address practices not related to physical injury.

PLEASE NOTE

Electrical equipment should be installed, operated, serviced, and maintained only by qualified personnel. No responsibility is assumed by Schneider Electric for any consequences arising out of the use of this material.

A qualified person is one who has skills and knowledge related to the construction and operation of electrical equipment and its installation, and has received safety training to recognize and avoid the hazards involved.

BEFORE YOU BEGIN

Do not use this product on machinery lacking effective point-of-operation guarding. Lack of effective point-of-operation guarding on a machine can result in serious injury to the operator of that machine.

 WARNING
UNGUARDED EQUIPMENT
<ul style="list-style-type: none">• Do not use this software and related automation equipment on equipment which does not have point-of-operation protection.• Do not reach into machinery during operation.
Failure to follow these instructions can result in death, serious injury, or equipment damage.

This automation equipment and related software is used to control a variety of industrial processes. The type or model of automation equipment suitable for each application will vary depending on factors such as the control function required, degree of protection required, production methods, unusual conditions, government regulations, etc. In some applications, more than one processor may be required, as when backup redundancy is needed.

Only you, the user, machine builder or system integrator can be aware of all the conditions and factors present during setup, operation, and maintenance of the machine and, therefore, can determine the automation equipment and the related safeties and interlocks which can be properly used. When selecting automation and control equipment and related software for a particular application, you should refer to the applicable local and national standards and regulations. The National Safety Council's Accident Prevention Manual (nationally recognized in the United States of America) also provides much useful information.

In some applications, such as packaging machinery, additional operator protection such as point-of-operation guarding must be provided. This is necessary if the operator's hands and other parts of the body are free to enter the pinch points or other hazardous areas and serious injury can occur. Software products alone cannot protect an operator from injury. For this reason the software cannot be substituted for or take the place of point-of-operation protection.

Ensure that appropriate safeties and mechanical/electrical interlocks related to point-of-operation protection have been installed and are operational before placing the equipment into service. All interlocks and safeties related to point-of-operation protection must be coordinated with the related automation equipment and software programming.

NOTE: Coordination of safeties and mechanical/electrical interlocks for point-of-operation protection is outside the scope of the Function Block Library, System User Guide, or other implementation referenced in this documentation.

START-UP AND TEST

Before using electrical control and automation equipment for regular operation after installation, the system should be given a start-up test by qualified personnel to verify correct operation of the equipment. It is important that arrangements for such a check be made and that enough time is allowed to perform complete and satisfactory testing.

WARNING

EQUIPMENT OPERATION HAZARD

- Verify that all installation and set up procedures have been completed.
- Before operational tests are performed, remove all blocks or other temporary holding means used for shipment from all component devices.
- Remove tools, meters, and debris from equipment.

Failure to follow these instructions can result in death, serious injury, or equipment damage.

Follow all start-up tests recommended in the equipment documentation. Store all equipment documentation for future references.

Software testing must be done in both simulated and real environments.

Verify that the completed system is free from all short circuits and temporary grounds that are not installed according to local regulations (according to the National Electrical Code in the U.S.A, for instance). If high-potential voltage testing is necessary, follow recommendations in equipment documentation to prevent accidental equipment damage.

Before energizing equipment:

- Remove tools, meters, and debris from equipment.
- Close the equipment enclosure door.
- Remove all temporary grounds from incoming power lines.
- Perform all start-up tests recommended by the manufacturer.

OPERATION AND ADJUSTMENTS

The following precautions are from the NEMA Standards Publication ICS 7.1-1995 (English version prevails):

- Regardless of the care exercised in the design and manufacture of equipment or in the selection and ratings of components, there are hazards that can be encountered if such equipment is improperly operated.
- It is sometimes possible to misadjust the equipment and thus produce unsatisfactory or unsafe operation. Always use the manufacturer's instructions as a guide for functional adjustments. Personnel who have access to these adjustments should be familiar with the equipment manufacturer's instructions and the machinery used with the electrical equipment.
- Only those operational adjustments actually required by the operator should be accessible to the operator. Access to other controls should be restricted to prevent unauthorized changes in operating characteristics.

About the Book



At a Glance

Document Scope

This document describes the functionality and performance scope of the BMXERT1604T/H module.

Validity Note

This documentation is valid for EcoStruxure™ Control Expert 15.0 or later.

The technical characteristics of the devices described in the present document also appear online. To access the information online:

Step	Action
1	Go to the Schneider Electric home page www.schneider-electric.com .
2	In the Search box type the reference of a product or the name of a product range. <ul style="list-style-type: none">• Do not include blank spaces in the reference or product range.• To get information on grouping similar modules, use asterisks (*).
3	If you entered a reference, go to the Product Datasheets search results and click on the reference that interests you. If you entered the name of a product range, go to the Product Ranges search results and click on the product range that interests you.
4	If more than one reference appears in the Products search results, click on the reference that interests you.
5	Depending on the size of your screen, you may need to scroll down to see the datasheet.
6	To save or print a datasheet as a .pdf file, click Download XXX product datasheet .

The characteristics that are described in the present document should be the same as those characteristics that appear online. In line with our policy of constant improvement, we may revise content over time to improve clarity and accuracy. If you see a difference between the document and online information, use the online information as your reference.

Related Documents

Title of documentation	Reference number
Modicon M580, M340, and X80 I/O Platforms, Standards and Certifications	EIO0000002726 (English), EIO0000002727 (French), EIO0000002728 (German), EIO0000002730 (Italian), EIO0000002729 (Spanish), EIO0000002731 (Chinese)
EcoStruxure™ Control Expert, Applicative Time Stamping, User Guide	EIO0000001268 (English), EIO0000001702 (French), EIO0000001703 (German), EIO0000001705 (Italian), EIO0000001704 (Spanish), EIO0000001706 (Chinese)
EcoStruxure™ Control Expert, System, Block Library	33002539 (English), 33002540 (French), 33002541 (German), 33003688 (Italian), 33002542 (Spanish), 33003689 (Chinese)
Modicon M580, Hardware, Reference Manual	EIO0000001578 (English), EIO0000001579 (French), EIO0000001580 (German), EIO0000001582 (Italian), EIO0000001581 (Spanish), EIO0000001583 (Chinese)

You can download these technical publications and other technical information from our website at www.schneider-electric.com/en/download.

Part I

Functional Overview

Overview

This part provides an overview of structure, architecture, functionality, and typical applications of the BMXERT1604T/H module.

What Is in This Part?

This part contains the following chapters:

Chapter	Chapter Name	Page
1	Introduction	13
2	User Functions	15
3	Applications	43

Chapter 1

Introduction

Module Overview

Brief Description of the Module

The BMXERT1604T/H module features all the characteristics of a regular 16-channel discrete input module. In addition, the BMXERT1604T/H module has a time stamping function which records the change (rising or falling edge) of each input channel. To ensure the precision of time stamps, the module is able to receive time codes from a GPS, or DCF77 receiver.

The time synchronization of the BMXERT1604T/H module with $SV \geq 2.0$ (associated with BMXERT1604.2 in the Control Expert device catalog) can also be done through the CPU or CRA via X Bus to address for example these specific cases when:

- GPS signal is not able to reach like applications underground.
- No extra GPS wiring on module terminal block is preferred.
- Unsupported time signal format like modulated IRIG-B is required.

The 16-channels discrete input can also be used as counter inputs; the counters feature increasing counting with the clear function.

The BMXERT1604T/H module inputs are compatible with the following rated voltages: 24 Vdc, 48 Vdc, 60 Vdc, 110 Vdc, and 125 Vdc. The inputs use positive (sink) logic.

BMXERT1604T/H Architectures

The BMXERT1604T/H module supports two kinds of architectures:

- Local architecture - The BMXERT module works with a BMX or BME CPU module in the local drop.
- Remote architecture - The BMXERT module works with a BMX or BME CRA (remote I/O adapter) module that is connected to a CPU via Ethernet. Refer to detailed compatibility rules (*see page 70*).

You can also refer to the Typical Applications topic (*see page 45*) for a detailed description.

Chapter 2

User Functions

Overview

The 16 inputs of the BMXERT1604T/H module can be individually preprocessed and transferred to the PLC as binary values, counter values, or events.

What Is in This Chapter?

This chapter contains the following sections:

Section	Topic	Page
2.1	Introduction	16
2.2	Discrete Input	18
2.3	Time Stamping Sub-functions	23
2.4	Counter Function	41

Section 2.1

Introduction

Main Functions

Overview

The BMXERT1604T/H module has 16 discrete inputs that can be configured with the following 3 main functions:

Counter: This function counts pulses from the discrete input channels.

Discrete input: Standard discrete input without time stamping.

Time stamping: The discrete input with the time stamps recorded to mark input state changes.

The inputs are in 4 groups that contain 4 input channels in each group. Input functions can be configured by input group:

Input Group	Input Channels	Selectable Functions
0	0, 1, 2, and 3	Only time stamping
1	4, 5, 6, and 7	Counter Discrete input Time stamping (default)
2	8, 9, 10, and 11	Counter Discrete input Time stamping (default)
3	12, 13, 14, and 15	Counter Discrete input Time stamping (default)

To inhibit time stamping for:

- a channel in group 0, disable the channel
- For a channel in another group, either select a non-time stamping function or disable the channel

Subfunctions of Main Function

This table shows the subfunctions of each main function:

Main Function	Subfunction
Discrete input	Multi-voltage input ranks Debounce filter Enable Supply monitor
Time Stamping	Multi-voltage input ranks Debounce filter Dechatter filter Enable Edge detection Event storage Time synchronization Supply monitor
Counter	Multi-voltage input ranks Debounce filter Dechatter filter Enable Edge detection Counting function Supply monitor

Logical View

The following figure shows the logical view of the BMXERT1604T/H module:

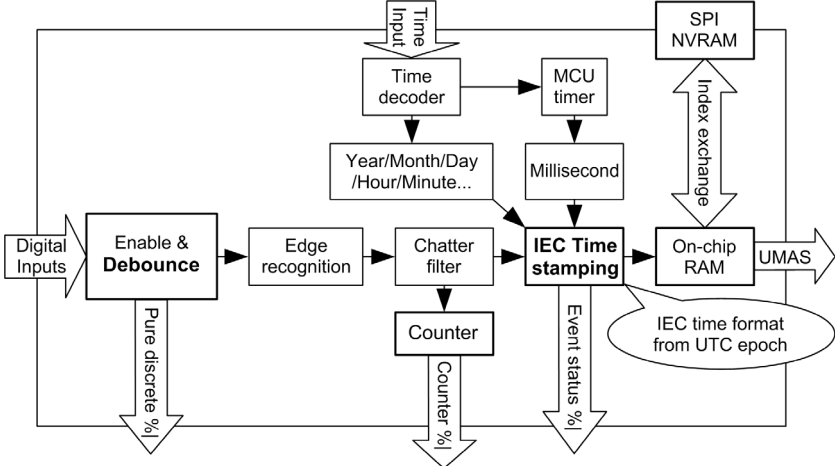

Section 2.2

Discrete Input

Overview

This section describes discrete input function of the BMXERT1604T/H module.

In discrete input, the basic value of each channel is transferred to the CPU by an implicit variable:

Parameter Type	Parameter Name	Valid Values	Details
Input implicit	Channel x value ($x = 0...15$)	0 = Logical level 0 1 = Logical level 1	Available in: <ul style="list-style-type: none"> ● Device DDT ● IODDT ● Debug screen

What Is in This Section?

This section contains the following topics:

Topic	Page
Enable and Disable Discrete Inputs	19
Multi-voltage and Supply Monitor Sub-functions	20
Debounce Filter	21

Enable and Disable Discrete Inputs

Overview

You can enable or disable each discrete input channel:

Parameter	Symbol	Valid Values	Description	
Configuration	Channel x used ($x = 0 \dots 15$)	0: Enable 1: Disable	Effective range: Organization:	Channel Each group

NOTE: The discrete input value of a disabled channel remains 0.

Multi-voltage and Supply Monitor Sub-functions

Overview

To adapt to different voltage ranges, the module supports 3 ranks for 5 rated voltages. This option is available for time stamping, discrete input, and counter functions.

The rated voltage configuration acquires the supply monitor function, which alarms the power interruption case for each rank.

The configuration allows disabling the supply monitor, otherwise the error message will be denoted by the variable (if enabled).

Parameter Description

Parameter Type	Parameter Symbol	Valid Values	Details	
Configuration	Rated voltage	0: 24 Vdc (default) 1: 48/60 Vdc 2: 110/125 Vdc	Effective range	Module
			Organization	Group 0
Configuration	Supply monitoring	0: Disable 1: Enable (default)	Effective range	Module
			Organization	Group 0

NOTE: If the **Supply monitoring** is enabled, the input state of each discrete channel is forced to 0 when a field supply failure is detected and the module stops the event detection until the field power supply recovers.

If the last input value is 1, then an event is generated when the input state is forced to 0 but the **TimeAccuracy** for this event shows an **IO Channel error**.

Status Description

Status Type	Status Symbol	Values	Details
Status Explicit	EXT_PWS_FLT	0: No fault 1: Power supply interruption for supply monitoring	Available in: <ul style="list-style-type: none"> ● Device DDT ● IODDT ● Fault screen

Debounce Filter

Overview

The purpose of the debounce function is to adapt the discrete input for mechanical switches. The programmable debounce filter can also be used to reduce the transient interference.

 CAUTION
UNEXPECTED BEHAVIOR OF APPLICATION - INCORRECT INTERPRETATION OF INPUT DATA
Debounce filters are used to suppress the input recognition in a defined way. Filtering should only be used in a suitable way to prevent too much or undesired suppression of input data.
Failure to follow these instructions can result in injury or equipment damage.

Debouncing inhibits the processing of fast state changes.

The value range for the filter time is 0...255 ms; the value 0 deactivates the debounce filter. The default value in Control Expert is 1.

A debounce filter may be one of the following:

- Steady State
- Integrating

This table shows the parameters for the debounce filter function:

Parameter	Symbol	Valid Values	Unit	Description	
Configuration	Debounce filter type	0: Steady state 1: Integrating	-	Effective range	Group
				Organization	Each group
Configuration	Channel <i>x</i> debounce time (<i>x</i> = 0...15)	0...255 (default: 1)	ms	Effective range	Channel
				Organization	Each group

NOTE:

- Excessive debounce time may cause the loss of effective events.
- Debounce time ≥ 1 ms is recommended to provide enough immunity from electromagnetic disturbances.
- The setting of debounce time affects the time stamping accuracy because the recognition of transition is delayed.

Steady State Filtering

A signal change is registered only if the polarity change remains stable for longer than the filter time (each new change resets the filter time):

Filter Time = 5 ms

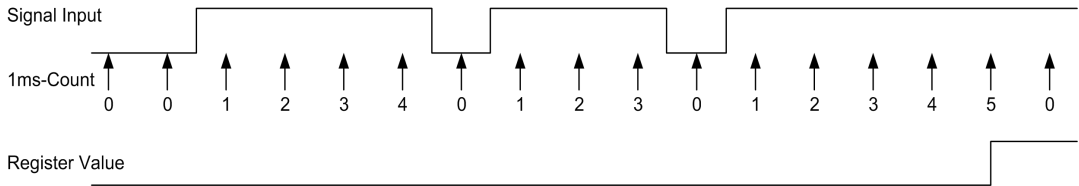

Integrating Filtering

A signal change is registered only if the time integral of the input signal reaches the programmed filter time considering any polarity change:

Filter Time = 5 ms

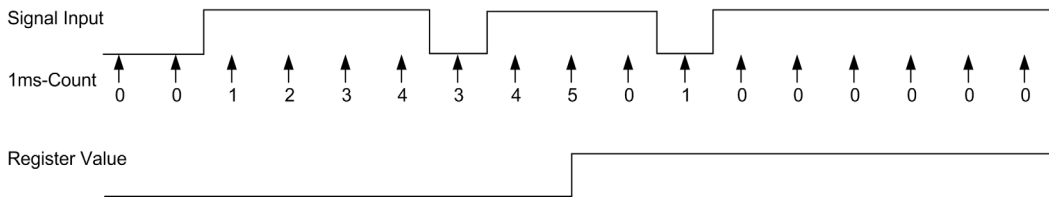

Section 2.3

Time Stamping Sub-functions

Overview

The time stamping function includes the full functions of discrete input (*see page 18*) containing the normal discrete input function along with the implicit variable presenting the input state for each channel.

The time stamping function also uses the following sub-functions:

- Dechatter filter
- Time synchronization
- Event storage

What Is in This Section?

This section contains the following topics:

Topic	Page
Edge Detection	24
Dechatter Filter	25
Time Synchronization	27
Event Storage	31
Behavior Mode	36
EFB for BMXERT1604T/H Module	40

Edge Detection

Overview

The BMXERT1604T/H module can detect the edge of state change on each discrete input channel. For time stamping function, the module always detects both rising and falling edges.

Parameter Type	Parameter Symbol	Valid Values	Description	
Configuration	Channel x edge ($x = 0...15$)	0: Both (default) 1: Rising (Only for counter) 2: Falling (Only for counter)	Effective range	Channel
			Organization	Each group

The following figure shows the input processing:

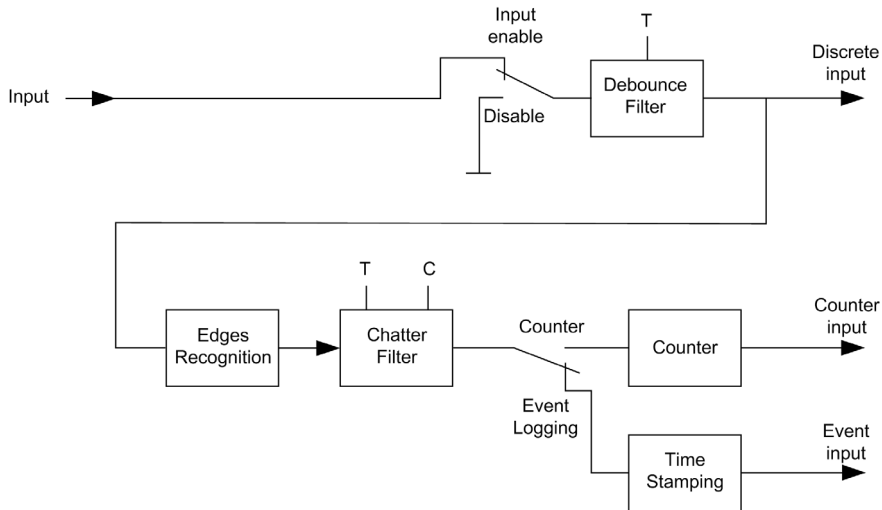

Dechatter Filter

Overview

 CAUTION
UNEXPECTED APPLICATION BEHAVIOR – INCORRECT INTERPRETATION OF INPUT DATA
Dechatter filters are used to suppress the input recognition in a defined way. Filtering should only be used in a suitable way to prevent too much or undesired suppression of input data.
Failure to follow these instructions can result in injury or equipment damage.

The dechatter function limits the number of events within a configurable value during a configurable time period. This filter reduces the number of event registrations for the same input so that events, such as low slew rate inputs, do not disturb the recording of desired events.

The dechatter filter requires the following two configurable parameters:

Chatter Counter (C): This value defines the first count (C) number of edges recorded. Edges received after this count (C) reached within a specified duration (T) are discarded. The value range is from 1...255.

Chatter Time (T): This value defines the duration for chatter time. The first rising or falling edge (or, the first edge after the end of last (T) confirms the beginning of current chatter time. Within the configured (T) only (C) number of edges is recorded. The value range is 1...255 where each number represents an unit of 100 ms (that is, 0.1...25.5 s).

The following figure shows the dechatter filter:

Dechattering=Yes; Both Edge=Yes; Chattering Count=3; Chattering Time=2 (x100 ms)

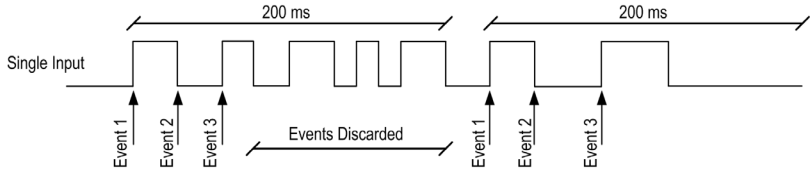

The following table describes the parameters and is provided with enable bit to activate or deactivate the dechatter filter:

Parameter Type	Parameter Symbol	Valid Values	Unit	Description	
Configuration	Chatter count	1...255 (default: 1)	–	Effective range	Channel
				Organization	Each group
Configuration	Chatter time	1...255 (default: 1)	100 ms	Effective range	Channel
				Organization	Each group
Configuration	Dechatter filter	0: Disable 1: Enable (default: 1)	–	Effective range	Group
				Organization	Each group
Implicit	Dechatter active	0: Inactive 1: Active	–	Available in: <ul style="list-style-type: none"> ● Device DDT ● IODDT ● Debug screen 	

The dechatter active bit describes the status of dechatter filter.

When an edge is discarded by dechatter filter, the dechatter active bit is set to 1 and is cleared at the end of current (T) duration.

NOTE: With the enabled dechatter filter and certain condition of input pattern, a recorded rising edge can be followed by another rising edge recorded (as shown in the previous figure), or a recorded falling edge can be followed by another falling edge recorded.

Time Synchronization

Overview

The BMXERT1604T/H module receives the broadcast time code input from the IRIG port, DCF port, or via X-bus (only 1 format is allowed at a time).

The external time codes not only provide the year, month, day, hour, minute, and second (IRIG-B) information, but also provide the on time edge at each second (IRIG-B) or minute (DCF77). This enables to synchronize the internal clock of the module with the external clock.

The following parameters are provided to support the time synchronization function:

Parameter Type	Parameter Name	Valid Values	Details	
Configuration	Clock SYNC source	0: Free running/internal clock 1: DCF77/external clock 2: IRIG-B/external clock (default) 3: CPU/CRA head/external clock	Effective range:	Module
			Organization:	Group 0
Implicit	TIME_VALID	0: Invalid 1: Valid	Available in: Device DDT IODDT Debug screen	
Implicit	CLOCK_FAILURE	0: No fail 1: Fail	Available in: Device DDT IODDT Debug screen	
Implicit	CLOCK_NOT_SYNC	0: Synchronized 1: Not synchronized	Available in: Device DDT IODDT Debug screen	

Clock SYNC Source

Source	Type	Description
Free running	Internal clock	The module uses the internal clock. After the module is initialized, the start time is changed to 1970-01-01 00:00:00:000 as defined in IEC61850.
DCF77	External clock	Timing is synchronized to a timing code received on the DCF input port.
IRIG-B	External clock	Timing is synchronized to a timing code received on the IRIG input port.
CPU/CRA head	External clock	Timing is synchronized via X-Bus, with: <ul style="list-style-type: none"> the CPU when the BMXERT1604T/H module is located on the local drop. the CRA head when the BMXERT1604T/H module is located on a remote X80 drop.

NOTE: When the external clock options are selected, the BMXERT1604T/H module stays in the free running mode (begins from 1970-01-01 00:00:00:000 after initialization) till the first successful synchronization with the external clock.

Clock Failure

An error message bit activates if the module detects that the time frame is invalid. When the external clock source is selected, an error message bit is asserted and the external time clock is detected as invalid.

The following conditions are considered invalid time frames, when:

- The wrong mark/space ratio for 0 or 1 signaling
- The wrong mark/space ratio for reference bit signaling
- The wrong check bit provided by DCF or IRIG
- The time frames are not continuous

This bit is cleared when a valid time frame is received and is continuous to current internal time. The initial value will be 1 after start.

NOTE: When the free running/internal clock option is selected, `CLOCK_FAILURE` always keeps 0.

Clock Not SYNC

When the external clock source is selected, the synchronizing effort reaches 10 s (IRIG-B) or 10 min. (DCF-77, or CPU/CRA head) without success, this bit is asserted to declare the `CLOCK_NOT_SYNC`. And it will be cleared once the time is synchronized. After initialization, this bit keeps 1 till the first successful synchronization.

NOTE: When the free running/internal clock option is selected, `CLOCK_NOT_SYNC` always keeps 1.

Time Valid

The value of this bit is decided by Clock SYNC source option, and the state of `CLOCK_FAILURE` and `CLOCK_NOT_SYNC` bits.

The (T) LED on the display panel which denotes the synchronization status acts base on the combination of these parameters:

Clock SYNC Source	CLOCK_FAILURE	CLOCK_NOT_SYNC	TIME_VALID	LED (T) (green)
IRIG-B, DCF77, or CPU/CRA head	0	0	1	ON
IRIG-B or DCF77	1	0	0	FLK
CPU/CRA head	0	1	0	
IRIG-B, DCF77, or CPU/CRA head	1	1	0	OFF
Internal Clock	0	1	0	

NOTE: Any status of the time quality bits (`TIME_VALID`, `CLOCK_FAILURE`, `CLOCK_NOT_SYNC`) will not stop the event recording for BMXERT1604T/H module.

NOTE: With an IRIG-B external clock, if IEEE1344 or IEEE C37.118 standards are not supported, then `CLOCK_FAILURE` and `CLOCK_NOT_SYNC` bits can be set to 1 during the switch between daylight saving time and standard time.

In any case, 13 seconds (IRIG-B external clock) or 13 minutes (DCF77, or CPU/CRA head external clock) after switch between daylight saving time and standard time, stamping time is synchronized with the external clock regardless the error bits status. Once synchronized, `CLOCK_FAILURE` and `CLOCK_NOT_SYNC` bits are reset.

Catch-up Mode

When the "on-time" edge is acquired from an external source, the BMXERT1604T/H module compares the newly acquired time with the (current) internal running time:

Comparison	Action
The new time is later than the internal running time.	The internal time is immediately updated to reflect the external time.
The new time is earlier than the internal running time.	The BMXERT1604T/H implements the catch-up mode, as described below.

In catch-up mode, the module retains the externally synchronized time, and the time stamp for the next incoming event is the result of the equation $last\ event\ stamp + 0.5\ ms$.

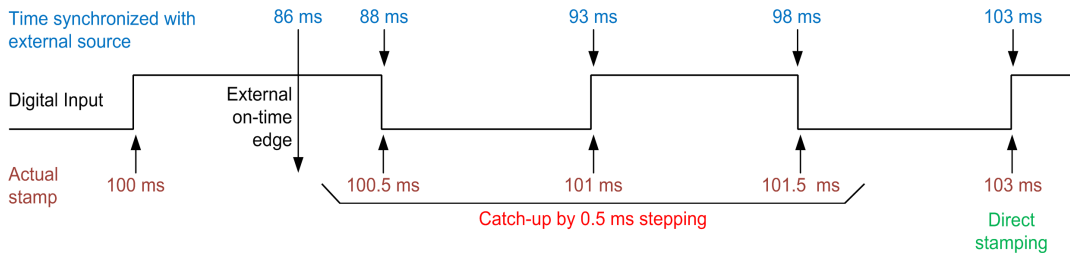

If the current externally synchronized time is later than the time stamp of the last event, the synchronized time can be used directly for the new incoming event, and catch-up mode is terminated.

NOTE: During the catch-up mode, TimeAccuracy value is set to 0xx11011 for the recorded events to indicate the `ClockInSync` status.

Event Storage

Event Data Format

A dedicated FIFO block provides space for storage and transfer of the event information.

The event data includes the information of edge polarity (rising or falling), event ID, and time quality.

The following table describes the FIFO space distributed for a time stamp data unit:

Reserved		Bit 7...0	Byte 0
Value		Bit 15...8	Byte 1
Event ID		Bit 7...0	Byte 2
		Bit 15...8	Byte 3
DateAndTime	SecondSinceEpoch	Bit 7...0	Byte 4
		Bit 15...8	Byte 5
		Bit 23...16	Byte 6
		Bit 31...24	Byte 7
	FractionOfSecond	Bit 7...0	Byte 8
		Bit 15...8	Byte 9
		Bit 23...16	Byte 10
TimeQuality			Byte 11

The following table describes the meaning of each data block:

Attribute Name	Attribute Type	Description/Value
Reserved (Byte 0)	BYTE	Reservation for future use. This byte is set to 0.
Value	BYTE	Value of the variable after change detection: Bit 0: Falling edge (0), Rising edge (1)
Event ID	WORD	Identification of the variable is automatically assigned by the configuration tool. NOTE: The identification must be unique for system time stamping.
DateAndTime	TIMESTAMP	Date and time of the variable change detection

The following table describes the format for `DataAndTime` data block:

Timestamp Type Definition		
Attribute Name	Type	Description/Value
<code>SecondsSinceEpoch</code>	INT32U	(0...MAX)
<code>FractionOfSecond</code>	INT24U	See the following table for more information on <code>FractionOfSecond</code>
<code>TimeQuality</code>	TIMEQUALITY	-

The time format is defined according to *IEC 61850-7-2 Edition 2*.

The definitions of the attributes are as follows:

SecondsSinceEpoch: Number of seconds since midnight (00:00:00) 1970/01/01 (UTC time).

FractionOfSecond:

FractionOfSecond	
SEC_1970_0...3	UINT32 little endian encoding
FRACT_SEC_0 (LSByte)	B7-B0
FRACT_SEC_1	B15-B8
FRACT_SEC_2 (MSByte)	B23-B16 (B23 = 1 for 1/2 s)
TimeQuality	B7-B0 (B7 = <code>LeapsSecondsKnown</code>)

FRACT_SEC_2 (MSByte)							FRACT_SEC_1 (2nd byte)							FRACT_SEC_0 (LSByte)									
23	22	21	20	19	18	17	16	15	14	13	12	11	10	9	8	7	6	5	4	3	2	1	0

The following table describes the format for `TimeQuality` data block:

TimeQuality Definition		
Attribute Name	Type	Description/Value
-	PACKED LIST (8 bits)	-
<code>LeapsSecondsKnown</code>	BOOLEAN (B7)	-
<code>ClockFailure</code>	BOOLEAN (B6)	-
<code>ClockNotSynchronized</code>	BOOLEAN (B5)	-
<code>TimeAccuracy</code>	CODED ENUM (B4...B0)	Number of significant bits in the <code>FractionOfSecond</code> Minimum time interval is 2 ^{**n}

For example, Encoding of `LeapSecond = 0`, `ClockFailure = 0`, `ClockNotSynchronized = 0`, `TimeAccuracy = 3` bits: `TimeQuality = 0x03`.

LeapSecondsKnown: This bit is set to FALSE.

ClockFailure: Indicates same meaning with the I% (implicit variable) CLOCK_FAILURE.

ClockNotSynchronized: Indicates same meaning with the I% (implicit variable) CLOCK_NOT_SYNC.

TimeAccuracy: In IEC norm, the TimeAccuracy represents the number of significant bits N in the FractionOfSecond.

- For the 1 ms time stamp resolution of BMXERT module, TimeAccuracy is set to 0xx01010.
- If ClockNotSynchronized = 1, or if ClockFailure = 1 the TimeAccuracy still keeps its usual value (as if the Clock is synchronized).

Time accuracy is also used to set specific values of TimeQuality as described in the following table:

TimeAccuracy Specific Values	Values	Comments
Invalid	0xx11110	Used in case of buffer full
IO Channel error	0xx11101	Used in case of IO Channel error detection
TSInit	0xx11100	Used in case of synchronization of the values with the client (done by storing a virtual event with 16-ch discrete values inside the buffer)
ClockInSync	0xx11011	Used in case of external clock during synchronization

If several errors are detected, the precedence of TimeAccuracy specific values are:

1. TimeAccuracy = IOChannelError (highest priority)
2. TimeAccuracy = Invalid or TSInit
3. TimeAccuracy = ClockInSync
4. TimeAccuracy = Unspecified

Event ID

Under system solution configuration, the event ID is assigned for each channel by the system to identify which channel the event belongs to. So that, this ID will be packed together with the event data package.

Parameter Type	Symbol	Valid Values	Description	
Configuration	Channel x event ID ($x = 0\dots15$)	Read-only	Effective range	Channel
			Organization	Each group

Under application solution, the event ID will be replaced by the topological address of the channel:

- 0...15 for channel x event ID
- 16 for SOE uncertain event ID

NOTE: Except the event ID for discrete channels, in case of buffer full, this event ID in the event buffer is loaded by SOE uncertain event ID to denote a buffer full or free event. For more details refer to the *Behavior Mode* (see page 36) section.

Event FIFO Management

The planned space for event storage is limited. You must consider an overflow buffer to handle conditions where the incoming rate of event bursts are greater than the event acquisition rate.

The following configuration and status parameters can be used to manage the overflow issues:

Parameter Type	Symbol	Valid Values	Unit	Description	
Configuration	Buffer threshold	Fixed by 70%	%	Effective range:	Module
				Organization:	Group 0
Configuration	SOE uncertain event ID	Read-only and assigned by system	-	Effective range	Module
				Organization	Group 0
Status Implicit	TIME_STAMP_RECORDS	0...Full value	-	Available in: Device DDT IODDT Debug screen	
Status Implicit	BUFF_FULL	0: No full 1: Full	-	Available in: Device DDT IODDT Debug screen	
Status Implicit	TS_BUF_FILLED_PCTAGE	0...100%	-	Available in: Device DDT IODDT Debug screen	

Parameter Type	Symbol	Valid Values	Unit	Description
Status Implicit	UMAS communication error	0: No error 1: Error	–	Available in: DDT Device IODDT Debug screen
Command Implicit	Clear event buffer	A rising edge from 0 to 1 clears the whole buffer NOTE: Only available for applicative time stamping mode.	–	Available in: Device DDT IODDT Debug screen

TIME_STAMPS_RECORDS: This word contains the number of time stamp records (event number) available in the local buffer.

BUFF_FULL: BUFF_FULL bit is set to 1 on buffer full detection. BUFF_FULL bit is cleared after a buffer full threshold is reached, that is, when percentage of events in the buffer is \leq buffer threshold (70%). Refer to the *Behavior Mode (see page 36)* for the module behavior for buffer full case.

The event record and detection always stops after the buffer is full. This means that the latest events are lost during the buffer full period.

Buffer threshold: After the buffer is full, the BMXERT module automatically recovers the event record when the buffer occupancy is lower than the buffer threshold.

PERCENTAGE_OF_BUFFER_FILLED: Both buffer threshold and TS_BUF_FILLED_PCTAGE use the percentage for indication. The percentages are calculated by group number instead of event number. The event number varies from 1...16 in one group. The number depends on how many channels get the events occurred within the same 0.5 ms sampling window.

SOE uncertain event ID: The buffer full event is treated as a special event from a virtual channel, therefore the unique event ID is assigned by the system. After the buffer full event occurs, the buffer full event with this ID is inserted into the event data sequence immediately. For more details refer to the *Behavior Mode (see page 36)* section.

The SOE uncertain ID is 16 under applicative solution mode. For more details refer to the *Event ID (see page 34)* topic.

Clear event buffer: A rising edge from 0 to 1 of this command implicit clears the whole event buffer. This parameter is only available for the applicative time stamping mode (*see page 117*).

NOTE: The **Clear event buffer** command must be used to clear the event buffer before the BMXERT1604T/H module is reassigned to new application. Otherwise, the remaining event data of last application can be kept in the buffer.

Behavior Mode

Overview

This section describes the module behavior modes for different phases or use cases. It involves the buffer management, the special features for system solution, and so on.

Time Stamping

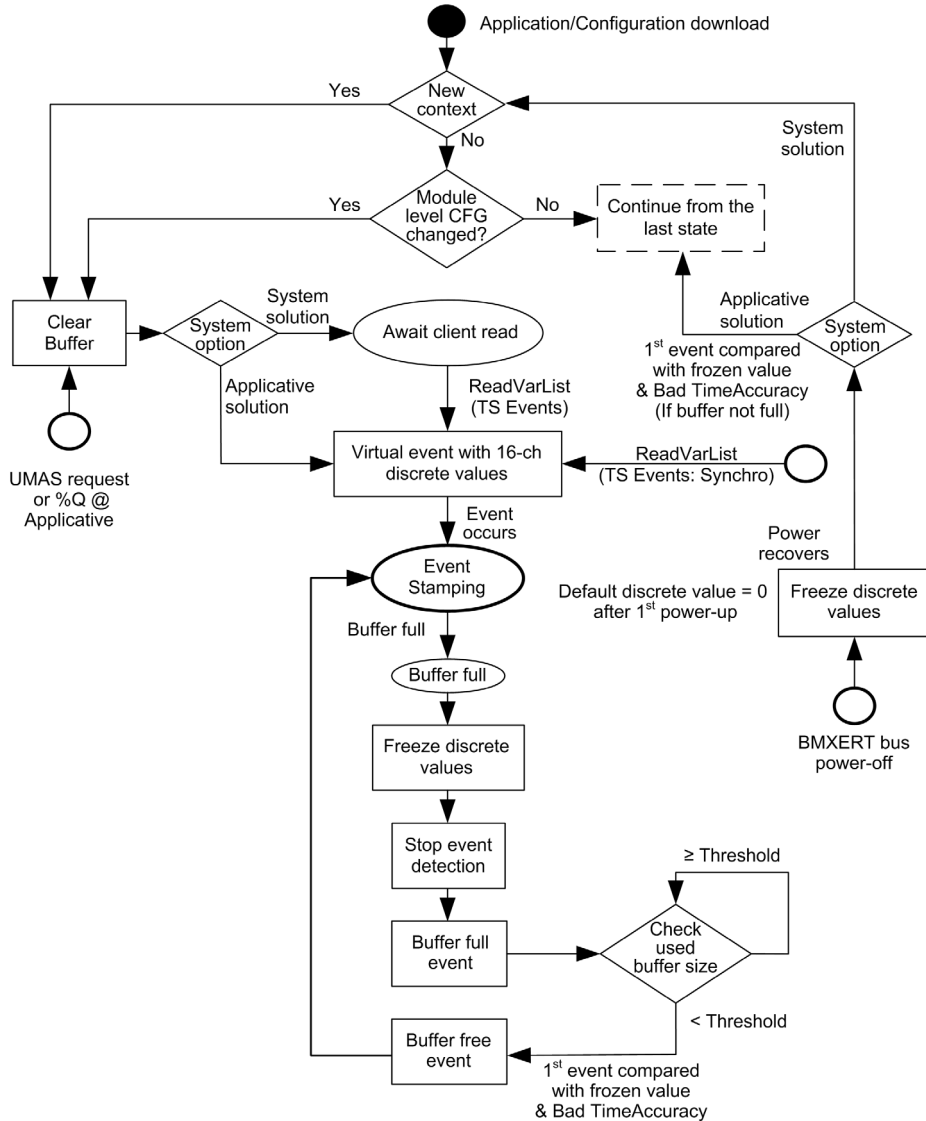

Application/Configuration Download

It includes all the operations which cause a physical download such as customer operation, auto download after power-on, and hot swap.

System/Application Solution

Parameter Type	Parameter Name	Valid Values	Details	
Configuration	Solution mode option	System or Applicative	Effective range:	Module
			Organization:	Group 0

NOTE: The system mode only takes time stamping channels into account.

New Context

The new context is defined as the occurrence of new configuration creation ID. The configuration creation is stored in the configuration parameter of BMX-ERT.

Parameter Type	Parameter Name	Valid Values	Details	
Configuration	Configuration creation ID	Read-only	Effective range:	Module
			Organization:	Group 0

Module Level CFG

The module level configuration parameters include:

- Related voltage
- Clock SYNC source

Client Read

Reception of a TS Events client request shows that the client is connected.

Client Demand to Synchronize the Values

Reception of a synchronization request from the TS Events client (sent in case of restart of the SCADA).

Virtual Event

The virtual event in the buffer queue is not generated for a real external event, it is provided to synchronize the values with the client. The values of discrete channels will be put in the event value byte of virtual event instead of the event polarity (rising or falling). The `TimeAccuracy` bits denote virtual event by 11100 as the `TSInit` symbol to be distinguished from normal events.

SOE_UNCERTAIN

The 0...1 transition of the implicit variable SOE_UNCERTAIN indicates that Sequence Of Events (SOE) begins to be uncertain, while the 1...0 transition signals when it is sure to be OK again. The BMXERT module generates the virtual events (include buffer full and free events) according to the transition of this bit like it does at the transition of discrete input channel for a real event.

Parameter Type	Parameter Name	Valid Values	Details
Implicit %I	SOE_UNCERTAIN	0: Certain 1: Uncertain	Available in: Device DDT IODDT Debug screen

The transition of SOE_UNCERTAIN will be applied for virtual event and buffer full/free event

SOE_UNCERTAIN Transition	Virtual Event (Value Synchro)	Buffer full/Free Event
0>1 (if not already 1)	When synchro request is received (includes init synchro)	When buffer-full is detected
1>0	When entering event stamping state	When entering event stamping state

Stop Event Detection

It means the detection for external events is stopped. But the virtual events corresponding to inserting time stamping channels is registered. Once it recovers, the virtual event is set in the buffer before the first external event is being put into this.

In addition to the 2 sources mentioned in the previous chart (buffer full or client demand to synchronize the values), the module also stops event detection on a field power supply fault phase (if the field power supply is monitored (*see page 20*)).

Bad TimeAccuracy

After recovering from the buffer free event or bus power off, the first event is compared with the last frozen discrete values, and the TimeAccuracy must be put as 11110 which denotes the invalid time. The buffer full/free event gets the normal TimeAccuracy bits (01010).

Initialization

The initialization means power-on, hot swap, application download, and module/group reboot after online configuration change.

BMXERT Field Power Failure Asserted

BMXERT field power failure asserted means the supply monitoring is enabled and the field power failure is detected.

EFB for BMXERT1604T/H Module

Overview

The following EFB are used to get the time stamp data in the BMXERT1604T/H module, depending on its location:

- GET_TS_EVT_M when the module is configured in a Modicon M340 or Modicon M580 system.
- GET_TS_EVT_Q when the module is configured in a Quantum system (Modicon X80 drop).

For detailed information on these EFB, refer to *EcoStruxure™ Control Expert, System, Block Library* ([see page 10](#)).

NOTE: The 2 EFBs are only available for an applicative time stamping solution (*see EcoStruxure™ Control Expert, Applicative Time Stamping, User Guide*).

Section 2.4

Counter Function

Counter Function

Overview

Besides the basic counting functions, the following sub-functions are also available:

- Debounce filter
- Dechatter filter
- Enable
- Edge detection
- Supply monitor

Counting Process

This function provides a simple incremental counter with reset function. If **Both Edge** option is selected, both rising and falling edges will be counted.

Refer to the General Specifications (*see page 66*) of counter function.

Parameter Type	Symbol	Valid Values	Description
Implicit	Channel <i>x</i> counter value (<i>x</i> = 0...15)	0...4294967295	Available in: Device DDT IODDT Debug screen
Implicit	Channel <i>x</i> clear counter value (<i>x</i> = 0...15)	A rising edge from 0 to 1 clears the counter	Available in: Device DDT IODDT Debug screen

NOTE: The counter value is volatile after backplane power down. The last counter value can be stored by user application.

Counter

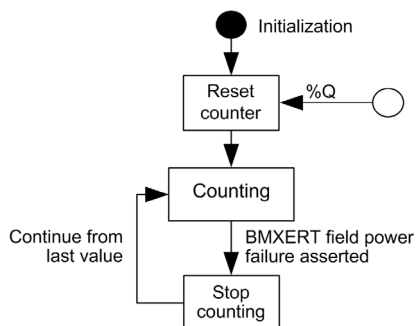

Counter steps description:

Initialization: Initialization is performed on following conditions:

- After application or configuration download of the BMXERT1604T/H module (including hot swap).
- Recovery after communication loss with CPU or BMX CRA 312 10.

Stop counting: The module only stops the counting after the field power failure is asserted.

Chapter 3

Applications

Overview

This chapter describes different applications used in this BMXERT1604T/H module.

What Is in This Chapter?

This chapter contains the following topics:

Topic	Page
Application Areas	44
Typical Applications	45

Application Areas

BMXERT1604T/H Application Areas

The following areas of application are valid for the BMXERT1604T/H module:

- Processing discrete input: Use as a standard input module with filtering in the range of 24...125 Vdc.
- Event time stamping: The event of an individual process status can be logged with the corresponding time (time stamp). Time stamping provides information that allows you to observe and evaluate the sequence of events in your process.
- Counter value: Use as a standard I/O module (with filtering, 32-bit summing with maximum 500 Hz) with an input range of 24...125 Vdc.
- Periodic time stamping of process values: Recording counter values in defined time intervals. The combined use of both function groups can be used as an advantage.
- Time dependent switching actions: The input modules can be set regardless of time for controlling lighting, heating, ventilators, temperatures (building automation), or for opening/closing doors, and machines (safety measures). The output status can be recorded with the ERT.

Typical Applications

Modicon M340 Architecture

This architecture has the following features:

- Power supply, DI and DO in 24 Vdc
- 8-channel RTD signal acquisition module
- Time stamping module with 1 ms resolution
- Modbus RS-485 communication with local serial line devices
- Modbus TCP Ethernet communication between LCU (Local Control Unit) and SCADA

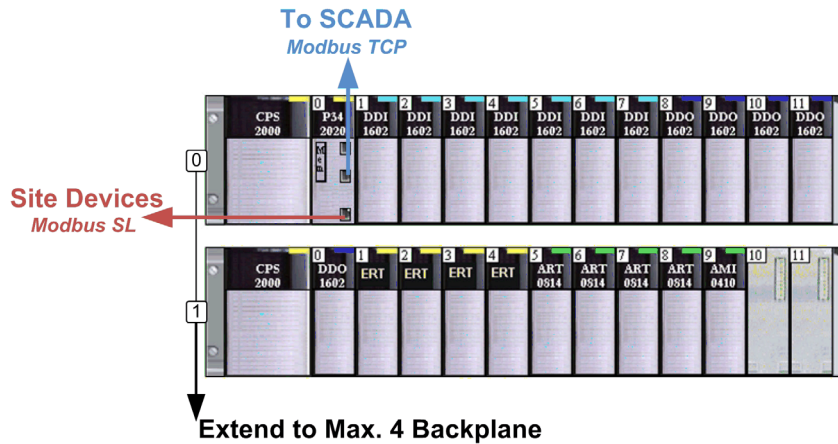

Modicon X80 Drop in a Quantum Architecture

This architecture has the following features:

- Standalone Quantum CPU or HSBY Quantum CPU head
- Bumpless switch over when HSBY system required, which has the same performance as the Quantum S908 HSBY system
- Power supply, DI and DO in 24 Vdc
- 8-channel RTD signal acquisition module
- Time stamping module with 1 ms resolution
- Modbus RS-485 or Modbus Plus communication with local serial line devices
- Dual Modbus TCP Ethernet communication between LCU (Local Control Unit) and SCADA

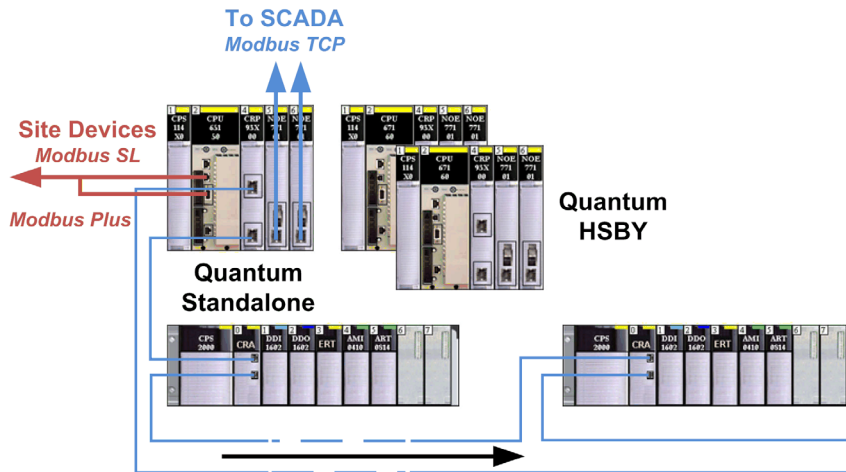

Modicon Mx80 with RTU Module

This architecture has the following features:

- Power supply, DI and DO range from 24...125 Vdc (the modules from Apollo project have supported the voltage range from 88 to 150 Vdc)
- Time stamping module with 1 ms resolution
- IEC 61131-2 zone C and IEC 61000-6-5 certification
- Modbus RS-485 or Modbus communication with local serial line devices
- RTU protocol supported with DNP 3.0, IEC 60870-5-101, IEC 60870-5-104, and Modbus TCP

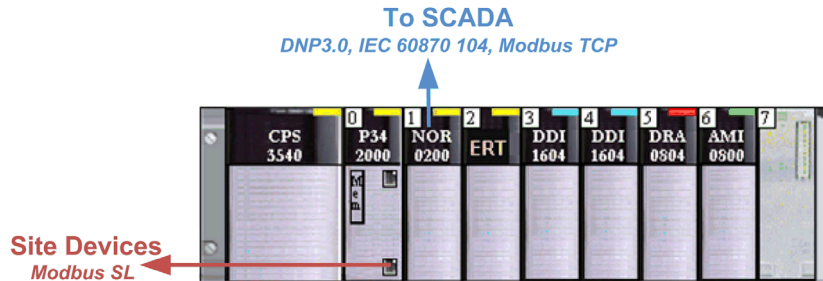

External Time Synchronization

In this sample configuration, the synchronized time is provided by an external GPS source:

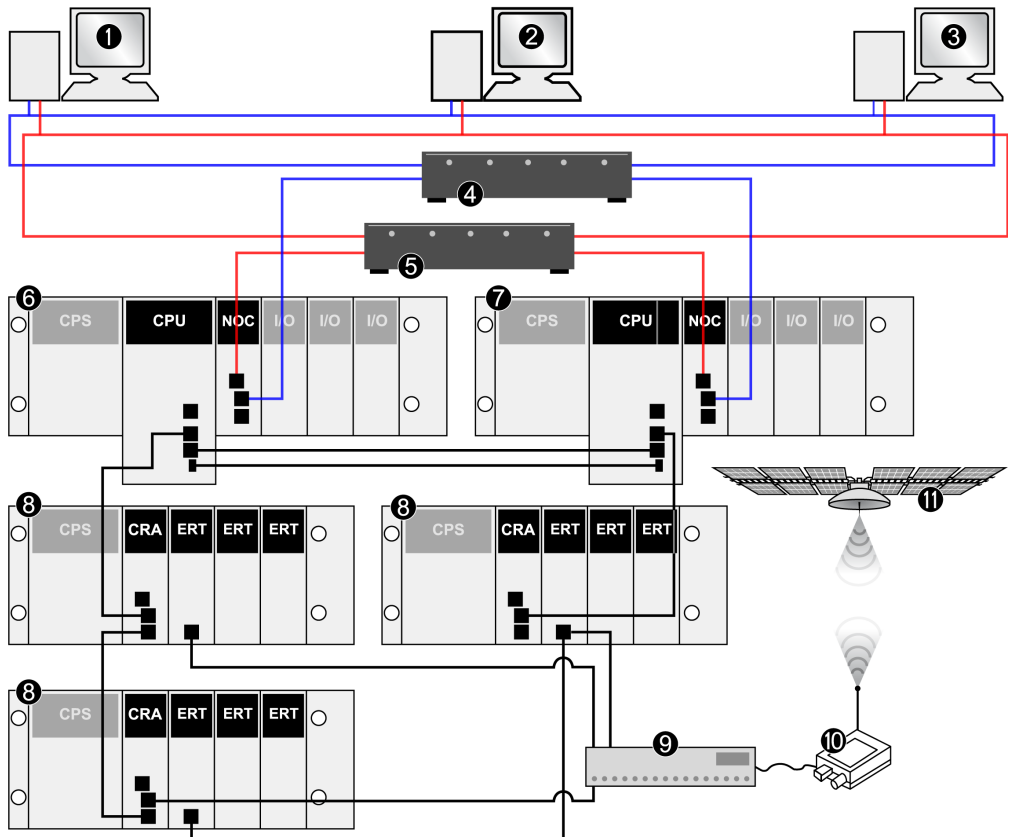

- 1 engineering station
- 2 operation station
- 3 maintenance station
- 4 blue network router
- 5 red network router
- 6 primary rack configuration
- 7 secondary rack configuration
- 8 remote I/O drop
- 9 third-party time server
- 10 GPS transmitter
- 11 satellite

In this sample configuration, the synchronized time for the M580 PAC system is provided by an NTP server:

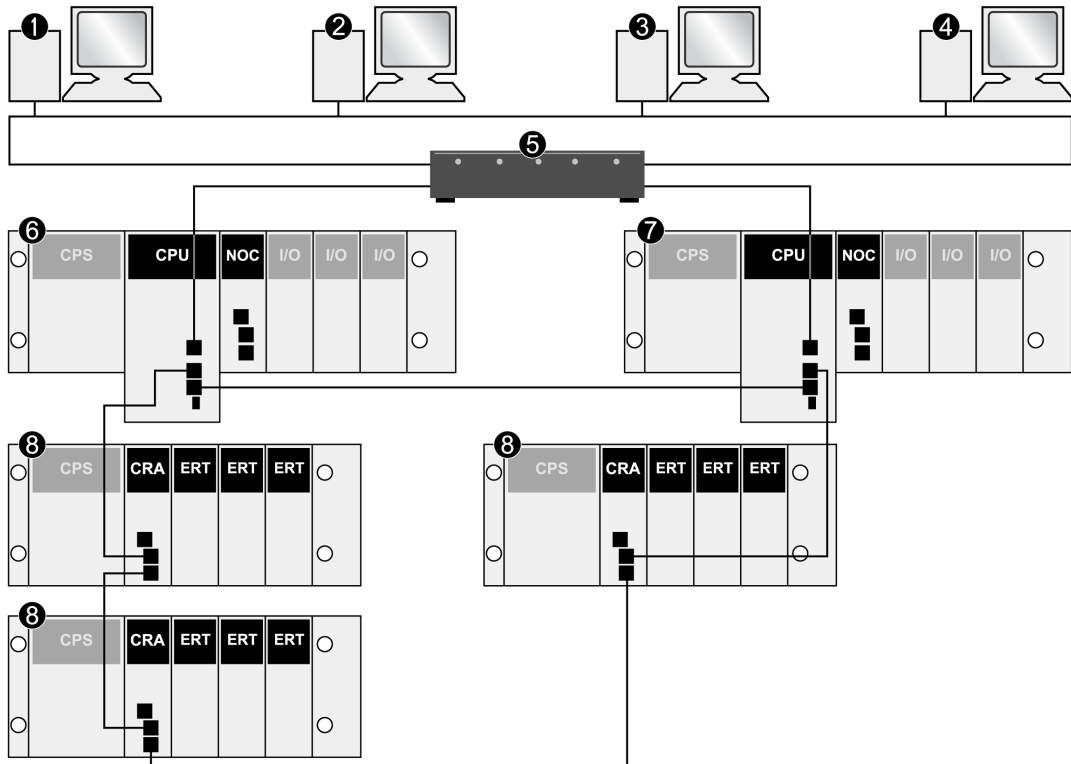

- 1 engineering station
- 2 operations station
- 3 maintenance station
- 4 NTP server
- 5 network router
- 6 primary rack configuration
- 7 secondary rack configuration
- 8 remote I/O drop

Typical Configuration with BMXERT1604.2 Module

Standalone M580 CPU + local main rack + extended main rack + remote rack

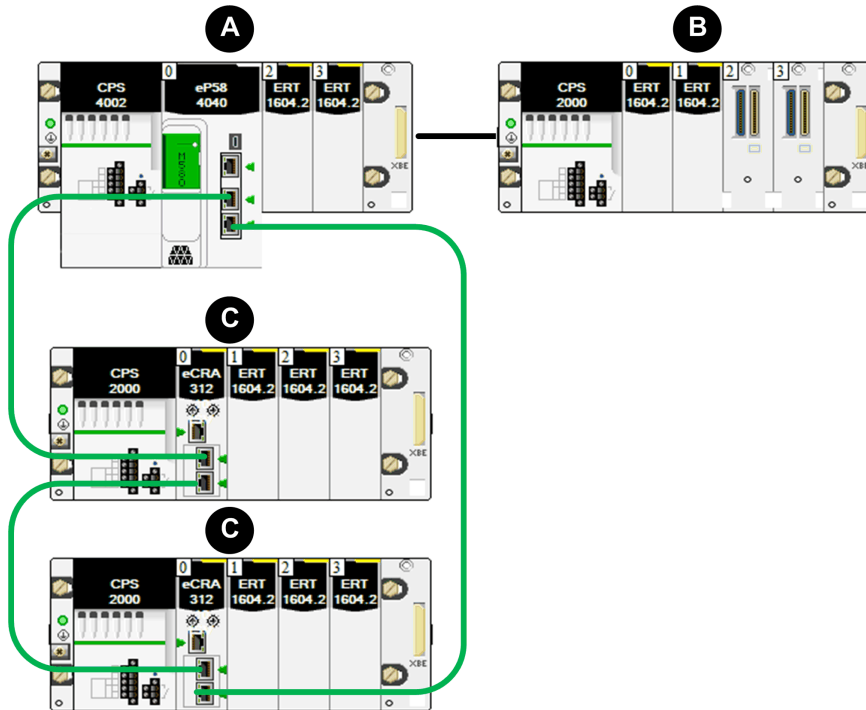

- A main local rack
- B extended local rack
- C remote rack

Maximum Time Difference	Value
two modules on the same rack (including an extended rack)	1 ms
two modules between the local and remote rack (with a BMXCRA31210 module)	12 ms
two modules between remote racks (with BMXCRA31210 modules)	7 ms
NOTE: The physical distance of the remote rack and the number of BMXCRA31210 modules installed do not increase the difference of time stamping values between the local and the remote rack.	

Part II

Physical Implementation

Overview

This part provides physical implementation of the BMXERT1604T/H module.

What Is in This Part?

This part contains the following chapters:

Chapter	Chapter Name	Page
4	Module Description	53
5	Guidelines for the Physical Installation	75

Chapter 4

Module Description

Overview

This chapter provides general information on presentation, mounting, specification, and wiring of the BMXERT1604T/H module.

What Is in This Chapter?

This chapter contains the following topics:

Topic	Page
Overview	54
Dimensions of X80 BMXERT1604T Time Stamping Module	56
28-Pin Terminal Blocks: BMX FTB 28•0	57
Standards and Certifications	61
Field Wiring	62
Diagnosis	65
Technical Data	66
Compatibility and Limitations	70

Overview

Introduction

The BMXERT1604T/H module is a multifunction expert module with 16-channel discrete input. This module is suitable for the evaluation of discrete input, counter pulses, and events.

Ruggedized Version

The BMXERT1604H (hardened) equipment is the ruggedized version of the BMXERT1604T equipment. It can be used in harsh chemical environments.

Both BMXERT1604T and BMXERT1604H equipments can be used at extended temperatures.

For more information, refer to chapter *Installation in More Severe Environments (see Modicon M580, M340, and X80 I/O Platforms, Standards and Certifications)*.

Front View of the Module

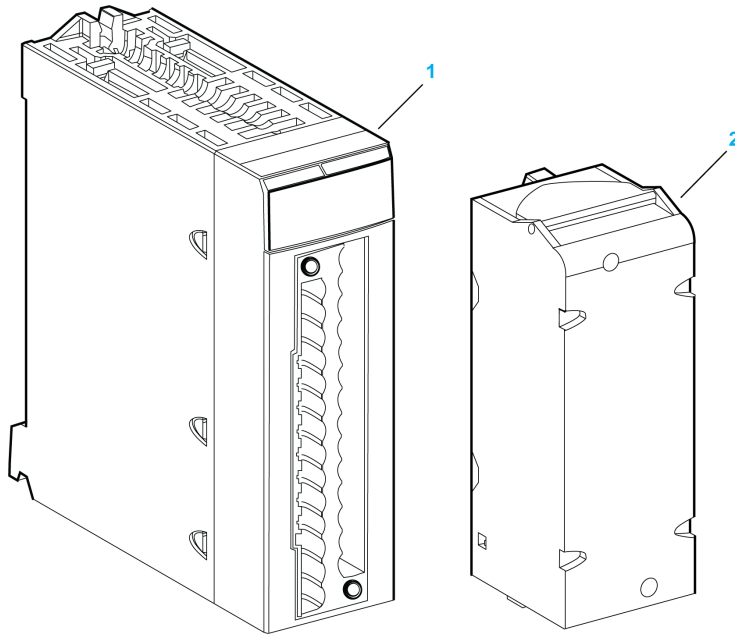

- 1 Module
- 2 28-pin removable terminal block (provided separately)

Accessories

The following table describes the accessories for the BMXERT1604T/H module:

Commercial Reference	Description
BMXXSP****	Shielding connection kit (<i>see page 82</i>)
BMXFTB2820	28-pin spring removable terminal block
BMXFTB2800	28-pin screw caged removable terminal block

Dimensions of X80 BMXERT1604T Time Stamping Module

General Presentation of X80 BMXERT1604T Time Stamping Module

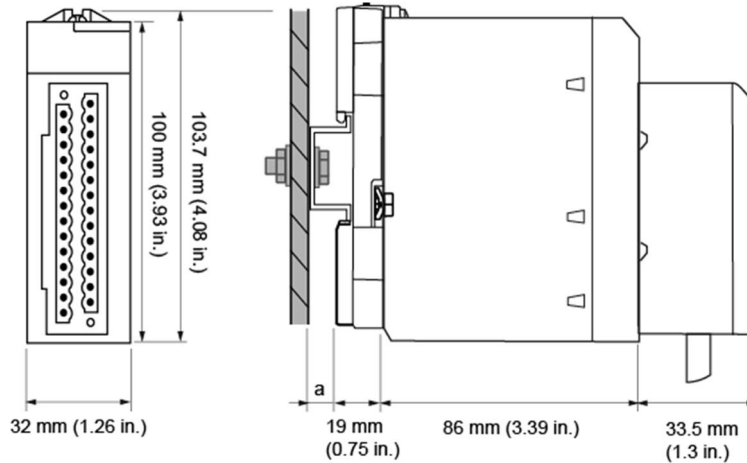

a DIN-rail depth: the value depends on the DIN-rail type used in your platform.

Dimensions of X80 BMXERT1604T Time Stamping Module

Module reference	Module dimensions			Installation depth ⁽¹⁾
	Width	Height	Depth	
BMXERT1604T	32 mm (1.26 in.)	103.7 mm (4.08 in.)	86 mm (3.39 in.)	119.5 mm (4.69 in.) ⁽¹⁾

(1) DIN-rail depth (a) is not included.

NOTE: Connectors that are delivered with BMXERT1604T modules (28-pin removable terminal blocks) and the corresponding pre-assembled cordsets (BMXFTW*08S) have the same dimensions.

NOTE: Consider clearance for cable installation and spacing around the racks.

28-Pin Terminal Blocks: BMX FTB 28•0



At a Glance

There are two types of 28-pin terminal blocks:

- BMX FTB 2800 caged terminal blocks
- BMX FTB 2820 spring terminal blocks

Cable Ends and Contacts







Each terminal block can accommodate:

- Bare wires:
 - Solid conductor
 - Stranded cable
- Wires with ferrules:
 - DZ5CE•••• single type cable ends: 
 - AZ5DE•••• twin type cable ends: 

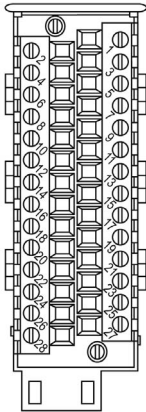
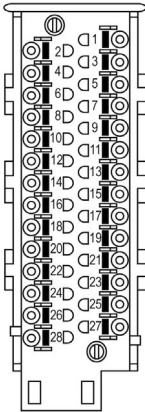
NOTE: When using stranded cable, Schneider Electric strongly recommends the use of wire ferrules which are fitted with an appropriate crimping tool.

Description of the 28-pin Terminal Blocks

The following table describes the type of wires that fit each terminal block and the associated gauge range, wiring constraints, and tightening torque:

	Caged terminal blocks BMX FTB 2800	Spring terminal blocks BMX FTB 2820
Illustration		
1 solid conductor 	<ul style="list-style-type: none"> ● AWG: 22...18 ● mm²: 0.34...1 	<ul style="list-style-type: none"> ● AWG: 22...18 ● mm²: 0.34...1
2 solid conductors 	Only possible with twin ferrule: <ul style="list-style-type: none"> ● AWG: 2 x 24...20 ● mm²: 2 x 0.24...0.75 	Only possible with twin ferrule: <ul style="list-style-type: none"> ● AWG: 2 x 24...20 ● mm²: 2 x 0.24...0.75
1 stranded cable 	<ul style="list-style-type: none"> ● AWG: 22...18 ● mm²: 0.34...1 	<ul style="list-style-type: none"> ● AWG: 22...18 ● mm²: 0.34...1
2 stranded cables 	Only possible with twin ferrule: <ul style="list-style-type: none"> ● AWG: 2 x 24...20 ● mm²: 2 x 0.24...0.75 	Only possible with twin ferrule: <ul style="list-style-type: none"> ● AWG: 2 x 24...20 ● mm²: 2 x 0.24...0.75
1 stranded cable with ferrule 	<ul style="list-style-type: none"> ● AWG: 22...18 ● mm²: 0.34...1 	<ul style="list-style-type: none"> ● AWG: 22...18 ● mm²: 0.34...1
2 stranded cables with twin ferrule 	<ul style="list-style-type: none"> ● AWG: 2 x 24...20 ● mm²: 2 x 0.24...0.75 	<ul style="list-style-type: none"> ● AWG: 2 x 24...20 ● mm²: 2 x 0.24...0.75

	Caged terminal blocks BMX FTB 2800	Spring terminal blocks BMX FTB 2820
Minimum individual wire size in stranded cables when a ferrule is not used 	<ul style="list-style-type: none"> ● AWG: 30 ● mm²: 0.0507 	<ul style="list-style-type: none"> ● AWG: 30 ● mm²: 0.0507
Wiring constraints	Caged terminal blocks have slots that accept: <ul style="list-style-type: none"> ● Flat-tipped screwdrivers with a diameter of 3 mm. Caged terminal blocks have captive screws. On the supplied blocks, these screws are not tightened.	The wires are connected by pressing the button located next to each pin. To press the button, you have to use a flat-tipped screwdriver with a maximum diameter of 3 mm.
Screw tightening torque	0.4 N•m (0.30 lbf-ft)	Not applicable

Connection of the 28-pin Terminal Blocks

⚡ ⚠ DANGER

HAZARD OF ELECTRIC SHOCK

Turn off all power to sensor and pre-actuator devices before connection or disconnection of the terminal block.

Failure to follow these instructions will result in death or serious injury.

The following diagram shows the method for opening the terminal block cover so that it can be wired:

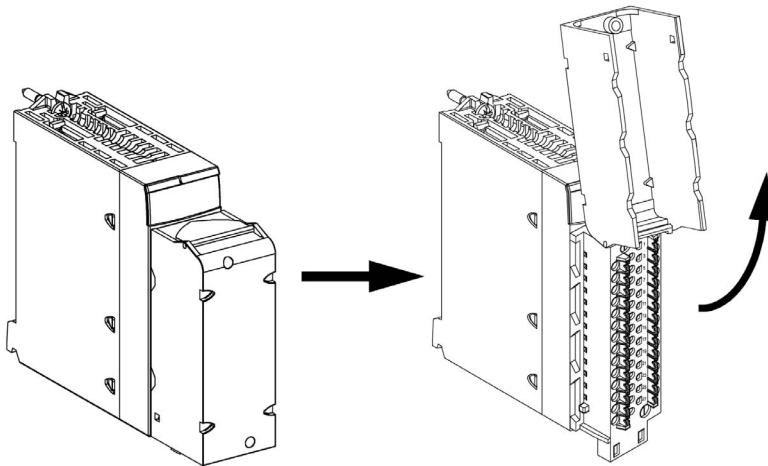

NOTE: The connection cable is installed and held in place by a cable clamp positioned below the 28-pin terminal block.

Labeling the Terminal Blocks

The labels for the terminal blocks are supplied with the module. They are to be inserted in the terminal block cover by the customer.

Each label has two sides:

- One side that is visible from the outside when the cover is closed. This side features the commercial product references, an abbreviated description of the module, as well as a blank section for customer labeling.
- One side that is visible from the inside when the cover is open. This side shows the terminal block connection diagram.

Standards and Certifications

Download

Click the link that corresponds to your preferred language to download standards and certifications (PDF format) that apply to the modules in this product line:

Title	Languages
Modicon M580, M340, and X80 I/O Platforms, Standards and Certifications	<ul style="list-style-type: none"><li data-bbox="679 391 948 415">● English: EIO0000002726<li data-bbox="679 418 948 443">● French: EIO0000002727<li data-bbox="679 446 948 470">● German: EIO0000002728<li data-bbox="679 474 948 498">● Italian: EIO0000002730<li data-bbox="679 501 948 526">● Spanish: EIO0000002729<li data-bbox="679 529 948 553">● Chinese: EIO0000002731

Field Wiring

Overview

The BMXERT1604T/H module uses one 28-pin terminal block (BMXFTB2820 or BMXFTB2800). This section describes the terminal pinning and wiring examples.

Field Sensors

The 16-channel discrete input support sensor signals from mechanical switching devices (operating in normal environmental conditions) such as relay contacts, limit switches, push buttons, 3-wire, and 2-wire proximity switches.

The sensor interface of BMXERT1604T/H module is designed base on the following rules:

Rank	Input Type
24 Vdc	IEC type 2
48 Vdc	IEC type 3
60 Vdc	
110 Vdc	$U_{OFF(max)} = 22\text{ V}$; $U_{ON(min)} = 79\text{ V}$; $U_{ON(max)} = 138\text{ V}$ $I_{OFF(max)} = I_{ON(min)} = I_{ON(max)} \approx 1.2\text{ mA}$
125 Vdc	$U_{OFF(max)} = 25\text{ V}$; $U_{ON(min)} = 91\text{ V}$; $U_{ON(max)} = 156\text{ V}$ $I_{OFF(max)} = I_{ON(min)} = I_{ON(max)} \approx 1.25\text{ mA}$

Time Code Sources

IRIG-B 004/5/6/7: The module receives external time codes in the IRIG-B 004/5/6/7 format through terminal block.

For detailed description of IRIG-B 004/5/6/7 format, refer to the *IRIG Standard 200-04*.

The physical signal of the time receiver output must be 5 Vdc differential type.

The specifications for the external transmitter are as follows:

- 1 external source is allowed to drive up to 32 BMXERT1604T/H modules.
- The minimum required level is 200 mV to activate the BMXERT1604T/H module.
- IEEE1344 or IEEE C37.118 standard extension definition for DST information must be supported in order to maintain time accuracy during the switch between daylight saving time and standard time.

DCF77: The module receives external time codes in the DCF77 format through terminal block.

For detailed description of DCF77 format, refer to the *DCF77* standard.

The required output level from external DCF77 source is 24 Vdc and follows the rules as such:

- The transition level between mark and space is about 13 Vdc
- The current consumption is about 3.6 mA (at 24 Vdc) for the DCF77 input port of each module
- 1 external source is allowed to be wired to multiple modules (the upper limit depends on the current capability of the source)

Pin Assignment

The following table defines the pin assignment for the 28-pin terminal block:

Definition	Pin Number		Definition
DCF_IN	2	1	IRIG+
DCF_COM	4	3	IRIG-
NC	6	5	NC
I1	8	7	I0
I3	10	9	I2
I5	12	11	I4
I7	14	13	I6
I9	16	15	I8
I11	18	17	I10
I13	20	19	I12
I15	22	21	I14
NC	24	23	NC
UB+	26	25	0 VDC
UB+	28	27	0 VDC

WARNING

UNEXPECTED BEHAVIOR OF APPLICATION

The wrong wiring will cause death, serious injury, or equipment damage.

Failure to follow these instructions can result in death, serious injury, or equipment damage.

Wiring Diagram

The following figure shows the wiring diagram of the BMXERT1604T/H module.

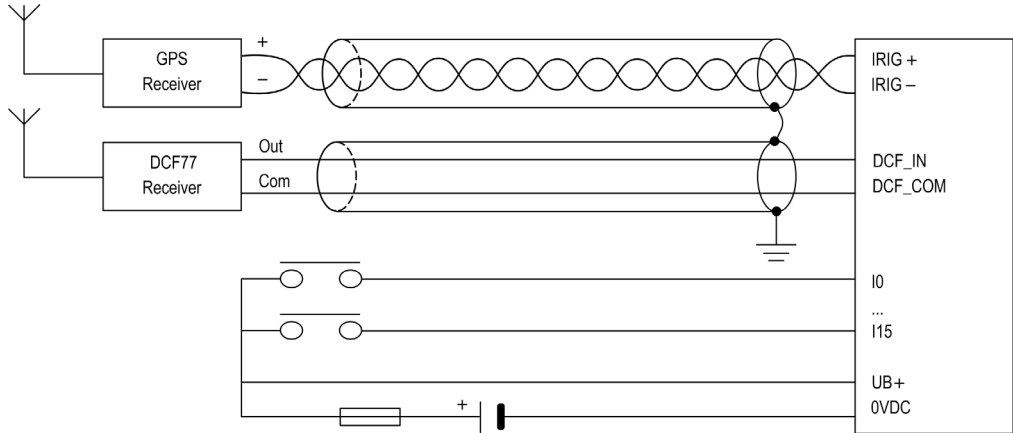

NOTE: The field power supply (*see page 68*) connected to UB+ and 0 VDC pins is an auxiliary power supply (different from the main power supply).

⚠ CAUTION

LOSS OF INPUT FUNCTION

The power supply to the sensors for I0...I15 **must be wired to UB+ and 0VDC** pins even if the supply monitoring function is not needed.

Failure to follow these instructions can result in injury or equipment damage.

Fuses

Internal	None
External	Fast blow fuse of 0.5 A

⚠ CAUTION

LOSS OF INPUT FUNCTION

Install the correct rating and type of fuse.

Failure to follow these instructions can result in injury or equipment damage.

Diagnosis

Overview

The LED panel is used to indicate the basic module status, the state of 16-channel discrete input, and the state of the time code synchronization.

The 4 LEDs **RUN**, **ERR**, **I/O**, and **T** are on the top of the panel.

LED Indicators

The following figure shows the LED indicators of the BMXERT1604T/H module.

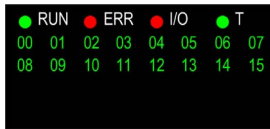

The 00...15 LED indicate the input states of 16-channel discrete input. The **T** LED indicates the status of time code input. The **T** LED and the **RUN** LED indicate the downloading state during the firmware downloading phase.

Description of Indication Pattern

The following table describes the LED indicators:

RUN	ERR	IO	T	00...15	Meaning
OFF					The module is not receiving power or inoperable
OFF	ON	OFF			The module is not operational
OFF	BLK	OFF	OFF		The module is not configured or is configuring its channels
ON	BLK	OFF	X		Module has lost communication with CPU
ON	OFF	ON	X	BLK	Field power supply interruption
BLK	OFF	OFF	BLK	X	Downloading firmware
ON	X	X	OFF	X	No external time code input
ON	X	X	FLK	X	External time code is temporarily unstable but internal time quality is acceptable
ON	X	X	ON	X	Module clock synchronized with external time code
ON	OFF	OFF	X	ON	The logical input 1 present on the corresponding channel
ON: LED is on. OFF: LED is off. FLK: The LED is on faster flashing (flickering). BLK: The LED is slower flashing (blinking). X: Do not care.					

Technical Data

Altitude Operating Conditions

The characteristics in the following table apply to the BMXERT1604T/H module for use at altitudes up to 2000 m (6560 ft). When the module operates above these altitudes, apply additional derating.

For detailed information, refer to the *Operating and Storage Conditions (see Modicon M580, M340, and X80 I/O Platforms, Standards and Certifications)* chapter.

General Specifications

Operating temperature		-25...70 °C (-13...158 °F)
Hot Swapping Supported		Yes
Event Sampling Rate		0.5 ms
Time Stamp Resolution	Within module	1 ms
	between modules (supplied by the same GPS time source)	1.5 ms to 2 ms
	between modules in same rack with CPU/CRA header time source (BMXERT1604.2 only)	1 ms
Absolute time stamp accuracy (without debounce filter)		<1 ms (see Note 1)
Time Input Synchronizing Duration	IRIG-B	<3 s
	DCF77	<3 min.
	CPU/CRA head	<10 min.
Maximum Event Buffer Capability		255 groups (see Note 2)
Event Data Protection (power-down)		Yes (Non-volatile)
Maximum Event Buffer Capability	Per UMAS Request	20 events
	Per EFB Request	20 events
Minimum Timeout Setting Between Reading Requests	Between UMAS Requests	5 ms
	Between EFB Requests	5 ms
<p>Note 1: The calibration approach is required to achieve this accuracy. The calibration takes 2 times of successful external synchronization to warm up. (The normal interval between each synchronization is 1 s for IRIG-B and 1 min for DCF77 or CPU/CRA head).</p> <p>Note 2: The event number contained in one group varies within 1...16. It depends on how many channels get the events occurred within same sampling window (that is, 0.5 ms).</p>		

Max Event Burst Within 1 s Without Buffer Being Full	Local (with 5 ms interval between requests)	4000 events/s
	RIO network (With Max BMXERT modules) (Max 16 reading requests/PLC cycle)	500 events/s (PLC cycle = 100 ms)
Counting Function	Counter Bits	32 bits
	Maximum Frequency	500 Hz
Backplane Power Consumption	+ 3.3 Vdc	130 mA
	+ 24 Vdc	30 mA
Isolation	Bus to discrete Input	2500 Vdc @ 1 min
	Bus to IRIG/DCF	1400 Vdc @ 1 min
	Discrete Input to IRIG/DCF	2500 Vdc @ 1 min
<p>Note 1: The calibration approach is required to achieve this accuracy. The calibration takes 2 times of successful external synchronization to warm up. (The normal interval between each synchronization is 1 s for IRIG-B and 1 min for DCF77 or CPU/CRA head).</p> <p>Note 2: The event number contained in one group varies within 1...16. It depends on how many channels get the events occurred within same sampling window (that is, 0.5 ms).</p>		

Discrete Input

Data of the process inputs:

Channel Number	16		
Group Organization	4 logical groups (not isolated from each other)		
Available Voltage Ranks	24 Vdc, 48 Vdc, 60 Vdc, 110 Vdc, and 125 Vdc		
Input Type of IEC61131-2	24 Vdc		Type 2
	48 Vdc and 60 Vdc		Type 3
	110 Vdc and 125 Vdc		Not applicable
24 Vdc	At 1	Voltage	11...30 V
		Current	≈ 6.7 mA
	At 0	Voltage	< 5 V
		Current	< 2.9 mA
48 Vdc	At 1	Voltage	30...60 V
		Current	≈ 2.5 mA
	At 0	Voltage	< 10 V
		Current	< 2.5 mA

60 Vdc	At 1	Voltage	39...75 V
		Current	≈ 2.5 mA
	At 0	Voltage	< 12 V
		Current	< 2.5 mA
110 Vdc	At 1	Voltage	79...138 V
		Current	≈ 1.3 mA
	At 0	Voltage	< 22 V
		Current	< 1.3 mA
125 Vdc	At 1	Voltage	91...156 V
		Current	≈ 1.3 mA
	At 0	Voltage	< 25 V
		Current	< 1.3 mA
Maximum Input Voltage			156 Vdc
Reverse Protection			Yes (-156 Vdc maximum)
Maximum Refreshing Rate			0.5 ms
Input Filter Response			0...255 ms (configurable)

Field Power Supply

Data of the field power supply:

Allowed Supply Range	24 Vdc	19...30 V
	48 Vdc and 60 Vdc	38...75 V
	110 Vdc and 125 Vdc	88...156 V
Power Failure Threshold	24 Vdc	≈ 17 V
	48 Vdc and 60 Vdc	≈ 34 V
	110 Vdc and 125 Vdc	≈ 82 V
	Performance	Power failure thresholds are always higher than 0/1 thresholds of discrete input
Supply Current	At all ranks	< 1 mA

NOTE: The voltage level of field power supply must be consistent with what is selected in the configuration interface.

Power Dissipation

Item	Description	
Module Power Dissipation	All channels with high level inputs (for all the ranks)	4 W

Time Code Inputs

Data of the time code inputs:

IRIG-B	IRIG format	IRIG-B 004/5/6/7
	Bit rate	100 pps
	Index count interval	10 ms
	Modulation	Pulse width code
	Carrier	No
	Coded expression	BCD _{TOY} , BCD _{YEAR} , CF, and CBS
	Physical signal	5 Vdc differential (RS-485 type)
	Mark condition	$V_A - V_B > 200$ mV
	Space condition	$V_B - V_A > 200$ mV
	Maximum rating	± 10 V
	Transmitter sharable	Up to 32 modules
DCF77	Bit rate	1 pps
	Index count interval	1000 ms
	Modulation	Pulse width code
	Carrier	No
	Coded expression	BCD
	Physical signal	24 Vdc single-ended
	Mark space threshold	≈ 13 V
	Input current	≈ 3.6 mA
	Maximum rating	± 30 V
	Transmitter sharable	Sharing number = Source capability/3.6 mA

CAUTION

UNEXPECTED BEHAVIOR OF APPLICATION

Wiring a DCF77 source wrongly to IRIG-B port will damage the BMXERT1604T/H module.

Failure to follow these instructions can result in injury or equipment damage.

Compatibility and Limitations

Overview

The number of the BMXERT1604T/H modules in a hardware configuration is linked to the:

- platform (M340, M580, and Quantum)
- module installation (in local rack or in remote drop)
- number of expert channels configured

NOTE: Each configured BMXERT1604T/H module consumes 4 expert channels.

- The **Time Stamping Mode** (only for M580) configured in the **Project Settings**.

When counting the number of expert channels in the configuration, take also into account that the Modbus port of the CPU (when present) is an expert channel.

When the application is built, Control Expert checks that the limitation is not exceeded.

Modicon M340

The minimum M340 PLC OS version required to use the BMXERT1604T/H module is V2.50.

The *time synchronization with CPU or CRA head modules via X Bus* feature is not compatible with the M340 PLC. You can not configure a BMXERT1604.2 device in a M340 application.

 CAUTION

UNEXPECTED BEHAVIOR OF APPLICATION

Before using the BMXERT1604T/H module in an M340 configuration, check that the OS version of the PLC is 2.50 or later.

Failure to follow these instructions can result in injury or equipment damage.

The maximum number of BMXERT1604T/H modules that can be configured in an M340 PLC station is linked to the:

- Modicon M340 PLC capabilities
- number of expert channels already configured

Architecture	CPU Reference	Maximum Expert Channels/CPU	Maximum Number BMXERT1604T/H Modules/CPU
Local Architecture	BMX P34 1000	20	4
	BMX P34 2000	36	8
	BMX P34 2010	36	8
	BMX P34 20102	36	8
	BMX P34 2020	36	8
	BMX P34 2030	36	9
	BMX P34 20302	36	9

Modicon M580

The *time synchronization with CPU or CRA head modules via X Bus* is available for BMXERT1604T/H modules with firmware V2.00 or later. In this case, the **Hardware Catalog** device to configure is BMXERT1604.2 (SV>=2.00).

NOTE: If you configure a device BMXERT1604.2 (SV>=2.00) and download to module with a firmware V1.30 or earlier, the *time synchronization with CPU or CRA head modules via X Bus* feature will not take effect, and the module will run in *free running* mode.

The following table give the availability and restrictions of the BMXERT1604T/H module functionalities in M580 local racks. The table give also the Control Expert Hardware Catalog devices to configure:

Module features and requirements		M580 local racks (Main and extended)		
BMXERT1604T/H Time synchronization	<ul style="list-style-type: none"> ● Free Running/Internal Clock, or ● DCF77/External Clock, or ● IRIG-B/External Clock 		Yes	Yes
	<ul style="list-style-type: none"> ● CPU/CRA Head External Clock 		No	Yes
Requirements	M580 CPU	Firmware version	All	Minimum V2.10
	BMXERT1604T/H	Firmware version	All	Minimum V2.00
		Control Expert Hardware Catalog device	BMX ERT 1604	BMX ERT 1604.2

The following table give the availability and restrictions of the BMXERT1604T/H module functionalities in X80 drops over M580 PAC (Stand-alone and Hot standby). The table give also the Control Expert Hardware Catalog devices to configure:

Module features and requirements		X80 drop over M580 PAC (main and extended remote racks)		
BMXERT1604T/H Time synchronization	<ul style="list-style-type: none"> ● Free Running/Internal Clock, or ● DCF77/External Clock, or ● IRIG-B/External Clock 	Yes	Yes	
	<ul style="list-style-type: none"> ● CPU/CRA Head External Clock 	No	Yes	
Requirements	M580 CPU	Firmware version	Minimum V2.00 ⁽¹⁾	Minimum V2.10
	BMXERT1604T/H	Firmware version	All	Minimum V2.00
		Control Expert Hardware Catalog device	BMX ERT 1604	BMX ERT 1604.2
	BMXCRA31210 Drop end communicator	Firmware version	Minimum V2.00	Minimum V2.14
		Control Expert Hardware Catalog device	BMXCRA31210 (SV>=2.00)	BMXCRA31210 (SV>=2.14)
	Or			
BMECRA31210 Drop end communicator	Firmware version	Minimum V2.00	Minimum V2.14	
	Control Expert Hardware Catalog device	BMECRA31210 (SV>=2.00)	BMECRA31210 (SV>=2.10)	
(1) For a M580 Hot Standby the minimum firmware is V2.10.				

In an M580 system, the maximum number of BMXERT1604T/H modules that can be configured follows the respective limitations imposed by the hardware configuration (local racks, X80 drops) and globally by the application.

Local racks: The maximum number of BMXERT1604T/H modules that can be configured in M580 local racks (that is local and extended local racks) is linked to:

- the maximum number of expert channels allowed in local configuration (*see Modicon M580, Hardware, Reference Manual*)
- the number of expert channels already configured

X80 drops: The maximum number of BMXERT1604T/H modules that can be configured in each X80 drop (with a BM•CRA31210 X80 performance EIO adapter module) follow these rules:

- a maximum of 36 expert channels
- a maximum of 9 BMXERT1604T/H modules configured

Application The maximum number of BMXERT1604T/H modules that can be configured in the application is dependent on the time stamping mode selected in **Project Settings → General → Time → Time Stamping Mode:**

System: a maximum of 25 BMXERT1604T/H modules supported by application.

Applicative: the maximum of BMXERT1604T/H modules supported by application is not limited.

NOTE: For M580 CPUs with OS V2.40 or earlier, the number of BMXERT1604T/H modules per application is limited to 25, whatever the time stamping mode.

Modicon Quantum

The *time synchronization with CPU or CRA head modules via X Bus* feature is not compatible with the Quantum PLC. You can not configure a BMXERT1604.2 device in a Quantum application.

The following table give the availability and restrictions of the BMXERT1604T module functionalities. The table give also the Control Expert Hardware Catalog devices to configure:

Module features and requirements		X80 drop over Quantum PLC (main and extended remote racks)	
BMXERT1604T/H Time synchronization	<ul style="list-style-type: none"> ● Free Running/Internal Clock, or ● DCF77/External Clock, or ● IRIG-B/External Clock 		Yes
	<ul style="list-style-type: none"> ● CPU/CRA Head External Clock 		No
Requirements	BMXERT1604T/H	Firmware version	All
		Control Expert Hardware Catalog device	BMX ERT 1604
	BMXCRA31210 ⁽¹⁾ Drop end communicator	Firmware version	Minimum V1.00
		Control Expert Hardware Catalog device	BMXCRA31210 (SV>=1.00)
	Or		
	BMECRA31210 ⁽²⁾ Drop end communicator	Firmware version	Minimum V2.00
Control Expert Hardware Catalog device		BMECRA31210 (SV>=2.00)	
(1) Requires a Quantum CPU with a firmware V3.10 or later			
(2) Requires a Quantum CPU with a firmware V3.20 or later			

The maximum number of BMXERT1604T/H modules that can be configured in the application is:

Architecture	CRA Reference	Maximum Expert Channels/CRA	Maximum Module Number/Drop (CRA)	Maximum Module Number/EIO Network
Remote I/O Architecture	BMXCRA31210 or BMECRA31210	36	9	25

NOTE: 1 expert channel = 1 ERT logical group.

Chapter 5

Guidelines for the Physical Installation

What Is in This Chapter?

This chapter contains the following topics:

Topic	Page
Installing the BMXERT1604T/H Time Stamping Module	76
Fitting 28-pin Terminal Blocks	78
Shielding Connection Kit	82

Installing the BMXERT1604T/H Time Stamping Module

Overview

The BMXERT1604T/H time stamping module is powered by the backplane bus. The modules may be handled without turning off power supply to the rack, without causing any danger and without any risk of damage or disturbance to the PLC.

The fitting operations (installation, assembly, and disassembly) are described below.

Installation Precautions

The BMXERT1604T/H module may be installed in any of the positions in the rack except:

- the positions reserved for the rack power supply modules (marked PS, PS1, and PS2),
- the positions reserved for extended modules (marked XBE),
- the positions reserved for the CPU in the main local rack (marked 00 or marked 00 and 01 depending on the CPU),
- the positions reserved for the (e)X80 adapter module in the main remote drop (marked 00).

Before installing a module, take off the protective cap from the module connector located on the backplane.

DANGER

ELECTRICAL SHOCK

- If the terminal block is connected to a shield bar while mounting/removing the modules, make sure that the terminal block is still connected to the shield bar.
- Remove the power to the sensors and pre-actuators.
- Disconnect the terminal blocks.

Failure to follow these instructions will result in death or serious injury.

Installation

The following figure shows the BMXERT1604T/H module mounted on the rack.

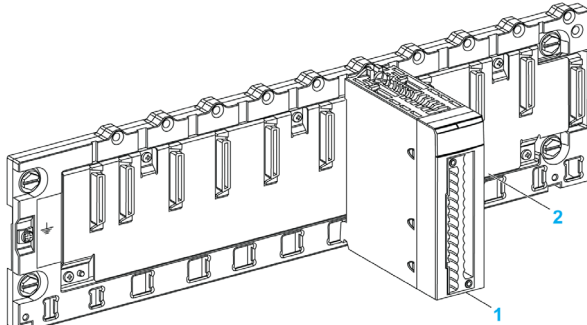

- 1 BMXERT1604T/H module
- 2 Standard rack

Installing the Module on the Rack

Mount the time stamping module in the rack:

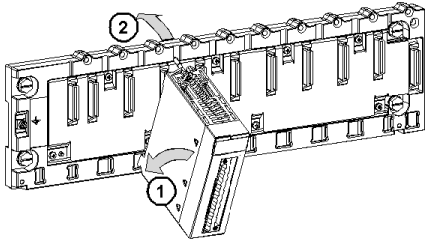
Step	Action	Illustration
1	Position the locating pins situated at the rear of the module (on the bottom part) in the corresponding slots in the rack.	Steps 1 and 2
2	Swivel the module towards the top of the rack so that the module sits flush with the back of the rack. It is now set in position.	
3	Tighten the mounting screw to ensure that the module is held in place on the rack. Tightening torque: 0.4...1.5 N•m (0.30...1.10 lbf-ft).	Step 3

Fitting 28-pin Terminal Blocks

Overview

BMXERT1604T/H module with 28-pin terminal block connection requires terminal block to be connected to the module. These fitting operations (assembly and disassembly) are described below.

⚠️ ⚠️ DANGER

ELECTRICAL SHOCK

Terminal block must be connected or disconnected with sensor and pre-actuator voltage switched off.

Failure to follow these instructions will result in death or serious injury.

Installing the 28-pin Terminal Block

The following figure shows the procedure for assembling the 28-pin terminal block onto a BMXERT1604T/H module.

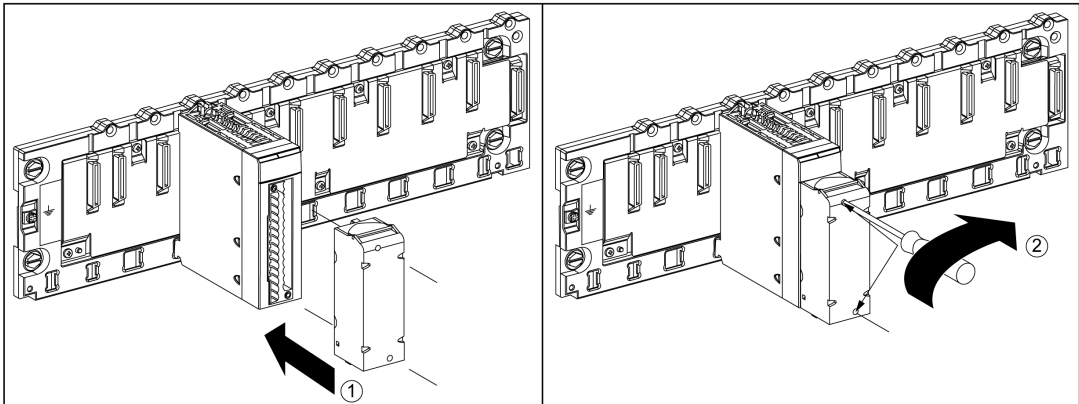

The following table describes the assembly procedure of the 28-pin terminal block onto a BMXERT1604T/H module:

Step	Action
1	Once the module is in place on the rack, install the terminal block by inserting the terminal block encoder (the rear lower part of the terminal) into the module's encoder (the front lower part of the module), as shown above.
2	Fix the terminal block to the module by tightening the 2 mounting screws located on the lower and upper parts of the terminal block. Tightening torque: 0.4 N•m (0.30 lb-ft).

NOTE: If the screws are not tightened, there is a risk that the terminal block will not properly fix to the module.

Coding the 28-Pin Terminal Block

WARNING

UNEXPECTED BEHAVIOR OF APPLICATION

Code the terminal block as described above to prevent the terminal block from being mounted on another module.

Plugging the wrong connector could cause unexpected behavior of the application.

Failure to follow these instructions can result in death, serious injury, or equipment damage.

CAUTION

DESTRUCTION OF THE MODULE

Code the terminal block as described above to prevent the terminal block from being mounted on another module.

Plugging the wrong connector could cause the module to be destroyed.

Failure to follow these instructions can result in injury or equipment damage.

When a 28-pin terminal block is installed on a module dedicated to this type of terminal block, you can code the terminal block and the module using studs. The purpose of the studs is to prevent the terminal block from being mounted on another module. Incorrect insertion can be avoided when replacing a module.

Coding is done by the user with the STB XMP 7800 guidance wheel's studs. You can only fill the 6 slots in the middle of the left side (as seen from the wiring side) of the terminal block, and can fill the module's 6 guidance slots on the left side.

To fit the terminal block to the module, a module slot with a stud must correspond to an empty slot in the terminal block, or a terminal block with a stud must correspond to an empty slot in the module. You can fill upto and include any of the 6 available slots as desired.

The following diagram shows a guidance wheel and the slots on the module used for coding the 28-pin terminal blocks.

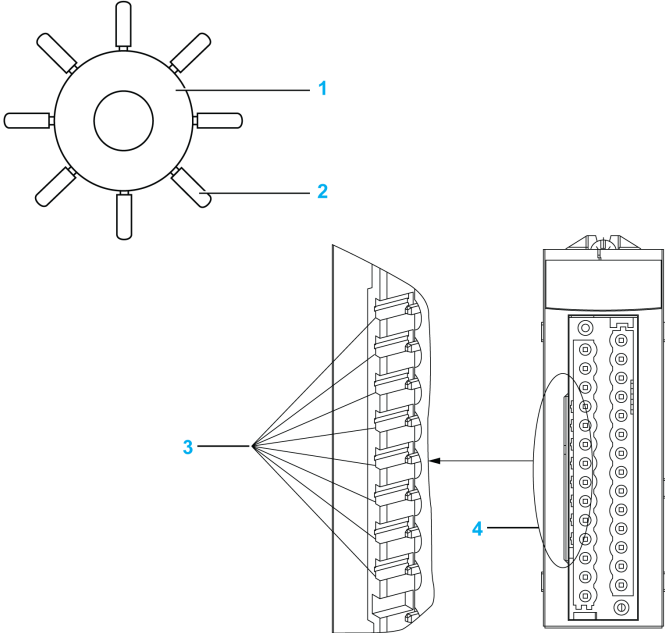

- 1 Guidance wheel
- 2 Detachable stud
- 3 Guidance slots
- 4 Module slots

The following diagram shows an example of a coding configuration that makes it possible to fit the terminal block to the module.

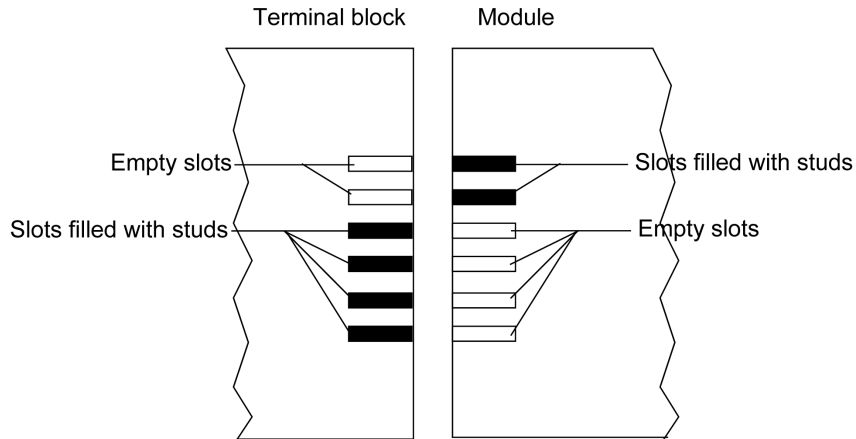

The following diagram shows an example of coding configuration with which it is not possible to fit the terminal block to the module.

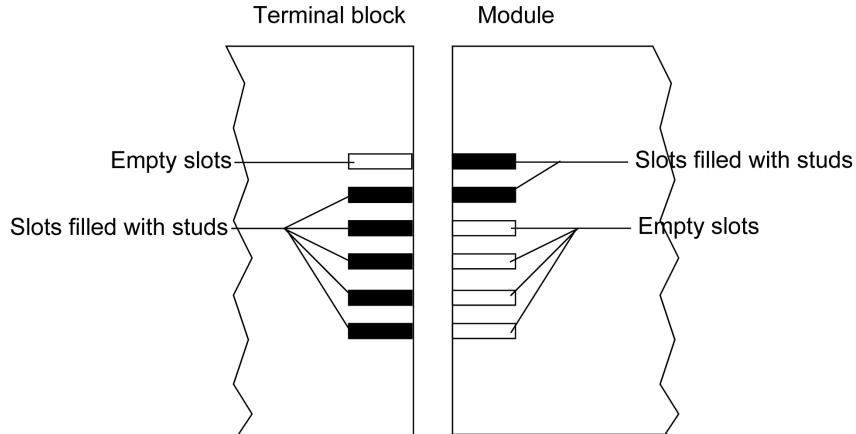

NOTE: The module connector has indicators which show the proper direction to use for terminal block installation.

Shielding Connection Kit

Introduction

The BMXXSP**** shielding connection kit allows to connect the cable shielding directly to the ground and not to the module shielding to help protect the system from electromagnetic perturbations.

Connect the shielding on the cordsets for connecting:

- Analog module,
- Counter module,
- Encoder interface module,
- Motion control module,
- An XBT console to the processor (via shielded USB cable).

Kit References

Each shielding connection kit includes the following components:

- A metal bar
- Two sub-bases

The shielding connection kit reference is dependent on the size of the Modicon X80 rack::

X bus racks/Dual Ethernet and X bus racks	Number of slots	Shielding Connection Kit
BMXXBP0400(H)	4	BMXXSP0400
BMEXBP0400(H)		
BMXXBP0600(H)	6	BMXXSP0600
BMXXBP0800(H)	8	BMXXSP0800
BMEXBP0800(H)		
BMXXBP1200(H)	12	BMXXSP1200
BMEXBP1200(H)		

Redundant power supply racks	Number of slots	Shielding Connection Kit
BMEXBP0602(H)	6	BMXXSP0800
BMEXBP1002(H)	10	BMXXSP1200

Clamping Rings

Use clamping rings to connect the shielding on cordsets to the metal bar of the kit.

NOTE: The clamping rings are not included in the shielding connection kit.

Depending on the cable diameter, the clamping rings are available under the following references:

- STBXSP3010: small rings for cables with cross-section 1.5...6 mm² (AWG16...10).
- STBXSP3020: large rings for cables with cross-section 5...11 mm² (AWG10...7).

Kit Installation

Installation of the shielding connection kit to the rack can be done with module already installed on the rack except for the BMXXBE0100 rack extender module.

Fasten the sub-bases of the kit at each end of the rack to provide a connection between the cable and the ground screw of the rack:

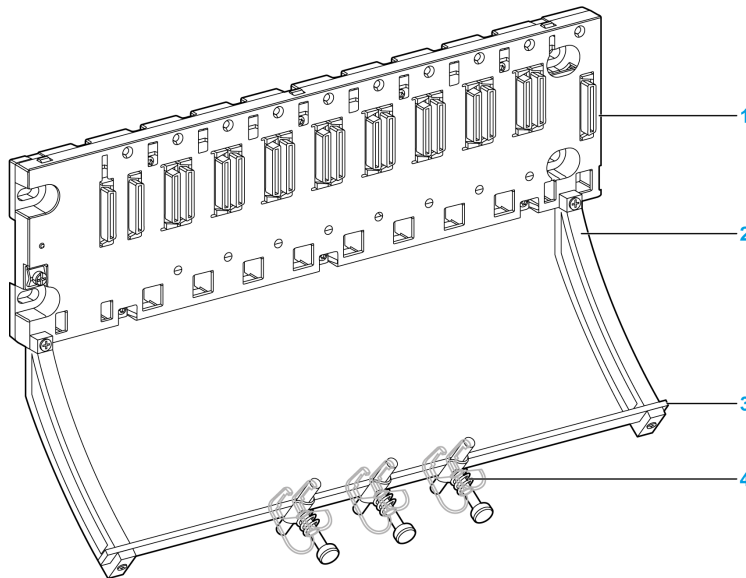

- 1 rack
- 2 sub-base
- 3 metallic bar
- 4 clamping ring

Tightening torques to install the shielding connection kit:

- For the screws fixing the sub-base to the Modicon X80 rack: Max. 0.5 N•m (0.37 lbf-ft)
- For the screws fixing the metallic bar to the sub-bases: Max. 0.75 N•m (0.55 lbf-ft)

NOTE: A shielding connection kit does not modify the volume required when installing and uninstalling modules.

Kit Dimensions

The following figure gives the dimensions (height and depth) of a Modicon X80 rack with its shielding connection kit:

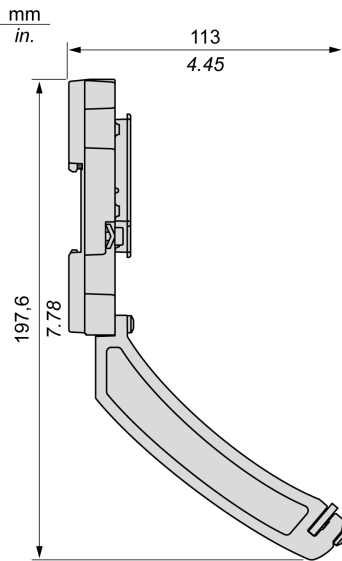

NOTE: The overall width equals to the width of the Modicon X80 rack.

Part III

BMXERT1604T/H Software Implementation

Overview

This part provides software implementation and functions of BMXERT1604T/H module.

What Is in This Part?

This part contains the following chapters:

Chapter	Chapter Name	Page
6	Configuration of BMXERT1604T/H Module	87
7	IODDTs and Languages Objects for the BMXERT1604T/H	119
8	Device DDT for the BMXERT1604T/H Module	129
9	Firmware Update	133

Chapter 6

Configuration of BMXERT1604T/H Module

Overview

This chapter describes the configuration of BMXERT1604T/H module.

What Is in This Chapter?

This chapter contains the following sections:

Section	Topic	Page
6.1	Using BMXERT1604T/H in Control Expert	88
6.2	User Screen for BMXERT1604T/H Module	90
6.3	Configuration Parameters for Channels	103
6.4	Configuration in Project Settings	115

Section 6.1

Using BMXERT1604T/H in Control Expert

Inserting BMXERT1604T/H in the Rack

Versions Requirements

Component	Version
Unity Pro/Control Expert	V 7.0 ⁽¹⁾ or later
Modicon M340 processor	OS V2.5 or later
Modicon M580 processor	OS V2.0 or later

⁽¹⁾ BMXERT1604.2 requires Control Expert 14.1 or later.

NOTE: Unity Pro is the former name of Control Expert for version 13.1 or earlier.

Procedure

Insert the BMXERT1604T/H time stamping module in the configuration:

Step	Action
1	Double-click the rack slot which you want to insert the BMXERT1604T/H module to open the New Device dialog box.
2	Expand Discrete in the Part Number column to view the list of discrete modules.
3	<p>Double-click the BMXERT1604 or BMXERT1604.2 module depending on the firmware version you have in the module.</p> <p>NOTE: Choosing the BMXERT1604.2 device module allow time synchronization with CPU or CRA head modules via X-bus.</p> <p>Set the data model (Device DDT or topological) if necessary, depending on the location of the module (<i>see page 92</i>).</p>

Example:

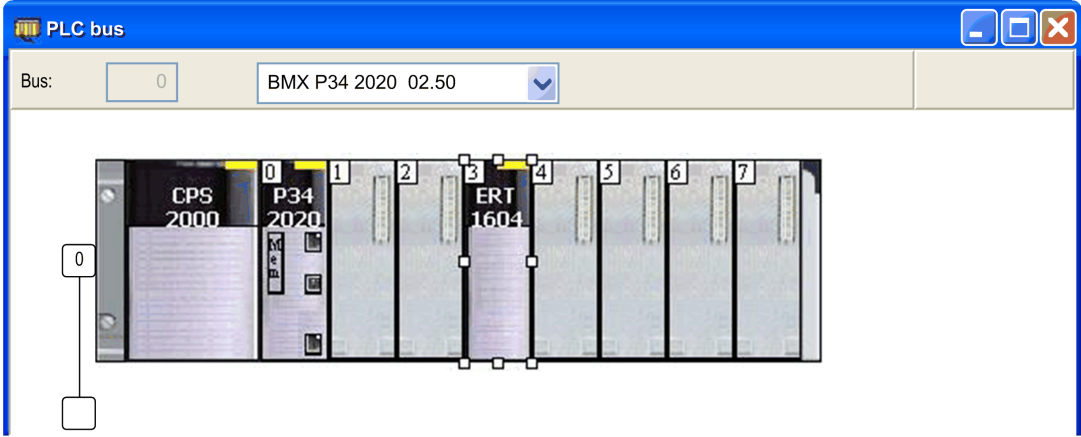

Section 6.2

User Screen for BMXERT1604T/H Module

Overview

This section describes the configuration screen for BMXERT1604T/H module.

What Is in This Section?

This section contains the following topics:

Topic	Page
User Screen Overview	91
Module Configuration	93
User Screen in Online Mode	96

User Screen Overview

Overview

To access the module screen, double-click the device bitmap in a slot and then click BMXERT1604T/H. This displays a module zone which includes a general parameter zone and available tabs.

The general parameter zone displays the module name BMXERT1604T/H on the left corner of the module screen.

The general parameter zone displays 4 secondary options allowing you to select the input group you want to configure:

- Channel 0...3 displayed as Channel 0
- Channel 4...7 displayed as Channel 4
- Channel 8...11 displayed as Channel 8
- Channel 12...15 displayed as Channel 12

The 3 tabs available for the module are as follows:

- **Overview**
- **I/O objects** or **Device DDT** depending on data model.
- **Fault** (displayed only when module fault detected online)

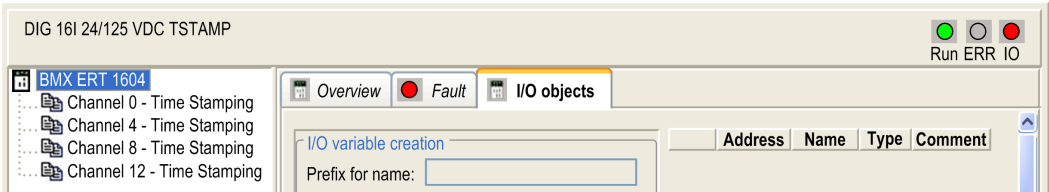

The 3 tabs available for the channels (by group) are as follows:

- **Configuration**
- **Debug** (online/local rack only)
- **Fault** (displayed only when channel fault detected online)

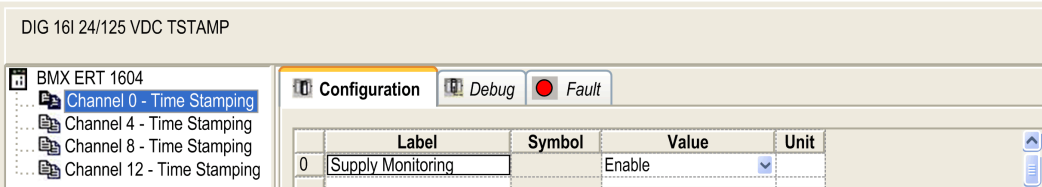

Module Location Differences

When the module is located in an X80 drop, the online display tabs are suppressed. Also, the **I/O objects** tab is replaced by the **device DDT** tab.

The following table shows the different accessible tabs for the module configuration according to its location:

Item		Local	X80 drop
Offline and Online		Overview	Overview
		Configuration	Configuration
Online		Debug	–
		Fault	–
Object management	Platform Quantum	–	Device DDT
	Platform M340	I/O objects (IODDT)	–
	Platform M580	I/O objects (IODDT) or Device DDT	Device DDT

Module Configuration

Overview Tab

Overview

16 sink inputs 24-125 VDC time stamp module

SPECIFICATIONS

Voltage	24 VDC, 48 VDC, 60 VDC, 110 VDC, 125 VDC
Modularity	16 channels
IEC 60131-2 conformity	Type 2 for 24 VDC Type 3 for 48/60 VDC None for 110/125 VDC
Time stamp resolution	1ms
Event buffer capability	255 groups

VISUAL INDICATORS

LED	Continually lit	Flashing	Blinking	Off
RUN (green)	Module operating normally			Module faulty or off
ERR (red)	Internal error: module failure	Communication error (if RUN LED is on) or module non configured (if RUN LED is off)		No internal error
I/O (red)	External error: sensor voltage error			No external error
T (green)	External time synchronized	External time temporarily lost	Downloading firmware	External time invalid
Channel 0..15 (green)	Channel at 1		External error: sensor voltage error	Channel at 0

IODDT

- T_ERT_TS_MOD
- T_ERT_TS
- T_ERT_CNT
- T_DIS_IN_GEN
- DDDT
- T_M_DIS_ERT
- DDT
- T_M_DIS_ERT_CH_STS

I/O Objects Tab

I/O objects tab displays objects, name, and an area for comment.

It allows you to manage I/O objects of the module by using the following functions:

- Display I/O objects with topological addressing
- Filter I/O objects
- Sort I/O objects
- Create an IODDT instance for the module
- Pre-symbolize a set of IODDT variables

DIG 16I 24/125 VDC TSTAMP

BMX ERT 1604

- Channel 0 - Time Stamping
- Channel 4 - Time Stamping
- Channel 8 - Time Stamping
- Channel 12 - Time Stamping

Overview
I/O objects

I/O variable creation

Prefix for name:

Type:

Comment:

I/O Objects

Channel: %CH

Configuration: %KW %KD %KF

System: %MW

Status: %MW

Parameter: %MW %MD %MF

Command: %MW %MD %MF

Implicits: %I %IW %ID %IF %IERR

%Q %QW %QD %QF

Update

	Address	Name	Type	Comment
1	%CH0.5.MOD			
2	%IO.5.MOD.ERR		BOOL	
3	%MW0.5.MOD		INT	
4	%MW0.5.MOD.1		INT	
5	%MW0.5.MOD.2		INT	
6	%CH0.5.0			
7	%KW0.5.0		INT	
8	%KW0.5.0.1		INT	
9	%KW0.5.0.2		INT	
10	%KW0.5.0.3		INT	
11	%KD0.5.0.4		DINT	
12	%KW0.5.0.6		INT	
13	%KW0.5.0.7		INT	
14	%KW0.5.0.8		INT	
15	%IO.5.0.ERR		BOOL	
16	%IO.5.0		EBOOL	
17	%Q0.5.0		EBOOL	
18	%ID0.5.0		DINT	
19	%IW0.5.0.2		INT	
20	%QW0.5.0		INT	
21	%QW0.5.0.1		INT	
22	%QW0.5.0.2		INT	
23	%QW0.5.0.3		INT	
24	%MW0.5.0		INT	
25	%MW0.5.0.1		INT	
26	%MW0.5.0.2		INT	

PLC bus
0.5: BMX E...

NOTE: You can create and associate variables to objects, but cannot delete variables from this page.

Device DDT Tab

The following figure shows the **Device DDT** tab for the BMXERT1604T/H module:

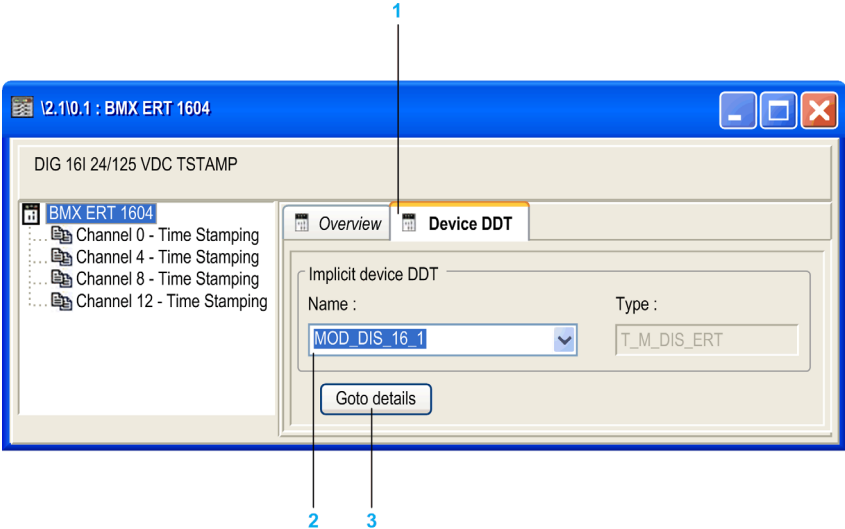

- 1 Device DDT Tab
- 2 Device name automatically attributed
- 3 Command button to display device DDT details

User Screen in Online Mode

Fault Tabs

The **Fault** pages display detected error status for the module and each channel.

Module Fault Tab

This tab is displayed when there is a detected error of the module, and a red dot is shown with the tab name.



Module Fault Parameters:

Object	Type	Symbol	Description
%lr.m.MOD.ERR	BOOL	MOD_ERROR	Module detected error bit
%MWr.m.MOD.2	INT	MOD_FLT	Internal detected error INT of the module
x0	BIT	MOD_FAIL	Internal detected error, module detected failure
x1	BIT	CH_FLT	Inoperative channels
x2	BIT	–	Unused
x3	BIT	–	Module in self tests
x5	BIT	CONF_FLT	Hardware or software configuration detected error
x6	BIT	NO_MOD	Module missing or off

Channel Fault Tab

This tab is displayed when there is a detected error of the channel, and a red dot is shown with the channel item.

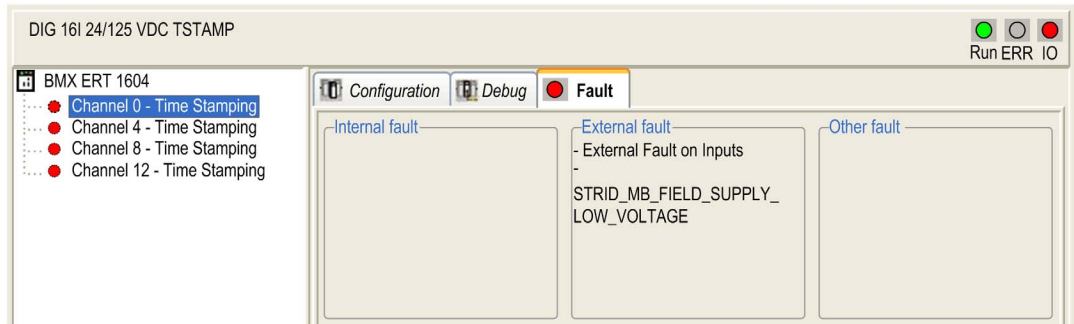

Channel Fault Parameters:

Type	Symbol	Description
EXTERNAL	CH_ERROR	External detected error on inputs
INTERNAL	INTERNAL_FLT	Inoperative channel
INTERNAL	CONF_FLT	Hardware or software configuration detected error
INTERNAL	COM_FLT	Module missing or off (detected error communication with PLC)
EXTERNAL	EXT_PWS_FLT	Power supply detected error for supply monitoring

Group 0 Debug Tab

Debug tab:

DIG 16I 24/125 VDC TSTAMP

BMX ERT 1604

- Channel 0 - Time Stamping
- Channel 4 - Counter
- Channel 8 - Counter
- Channel 12 - Discrete input

Configuration | **Debug** | Fault

Reference	Label	Symbol	Value	Unit
0	%IW0.3.0.3.0	TIME_VALID	No	
1	%IW0.3.0.3.1	Clock failure	1	
2	%IW0.3.0.3.2	Clock not SYNC	1	
3	%IW0.3.0.3.3	Buffer full	No	
4	%IW0.3.0.3.7	SOE uncertain	0	
5	%IW0.3.0.3.9	UMAS Communication error	No	
6	%IW0.3.0.3.15	Dechatter active	No	
7	%IW0.3.0.2	Time stamp records	16	
8	%IW0.3.0.4	Percentage of buffer filled	0	%
9	%IW0.3.0.5	Time stamp events state	48	
10	%IO.3.0.0	Channel 0 Value	0	
11	%Q0.3.0.0	Channel 0 Clear counter value	0	
13	%IO.3.1.0	Channel 1 Value	0	
15	%IO.3.2.0	Channel 2 Value	0	
17	%IO.3.3.0	Channel 3 Value	0	

Unforce

Function: Time Stamping

Task: MAST

PLC bus 0.3 : BMX E...

The parameters for the group 0 (channels 0...3) debug page are listed in the following table. Group 0 inputs are dedicated time stamping inputs, which cannot be reconfigured as counter or standard discrete input channels.

Object	Type	Label	Detail
%IW.r.m.0.3	INT	–	TS_DIAGNOSTIC_FLAGS
%IW.r.m.0.3.0	BOOL	TIME_VALID	Time OK and synchronized
%IW.r.m.0.3.1	BOOL	Clock failure	Same as <code>ClockFailure</code> . Indication in the <code>TimeQuality</code>
%IW.r.m.0.3.2	BOOL	Clock not SYNC	Same as <code>ClockNotSynchronized</code> . Indication in the <code>TimeQuality</code>
%IW.r.m.0.3.3	BOOL	Buffer full	Buffer full
%IW.r.m.0.3.7	BOOL	SOE uncertain	Variable to assign an SOE uncertain Event ID

Object	Type	Label	Detail
%IW.r.m.0.3.9	BOOL	UMAS Communication error	<Module Parameter> UMAS communication error
%IW.r.m.0.3.15	BOOL	Dechatter active	<Group Parameter> If any edges discarded by dechatter filter for any channels under this group.
%IW.r.m.0.2	INT	Time stamps records	<Module Parameter> This word contains the number of Time Stamp records available in the module local buffer
%IW.r.m.0.4	INT	Percentage of buffer filled	Percentage of the buffer filled [0...100]
%IW.r.m.0.5	INT	Time stamp events state	Main state of the TS events service (reserved)
%I.r.m.0.0	EBOOL	Channel 0 value	Channel 0 input value
%I.r.m.1.0	EBOOL	Channel 1 value	Channel 1 input value
%I.r.m.2.0	EBOOL	Channel 2 value	Channel 2 input value
%I.r.m.3.0	EBOOL	Channel 3 value	Channel 3 input value
%Q.r.m.0.0	EBOOL	Channel 0 Clear Counter value	<Module Parameter> Clear counter value

Group 1, 2 and 3 Time Stamping Debug Tab

Groups 1, 2 and 3 time stamping debug pages:

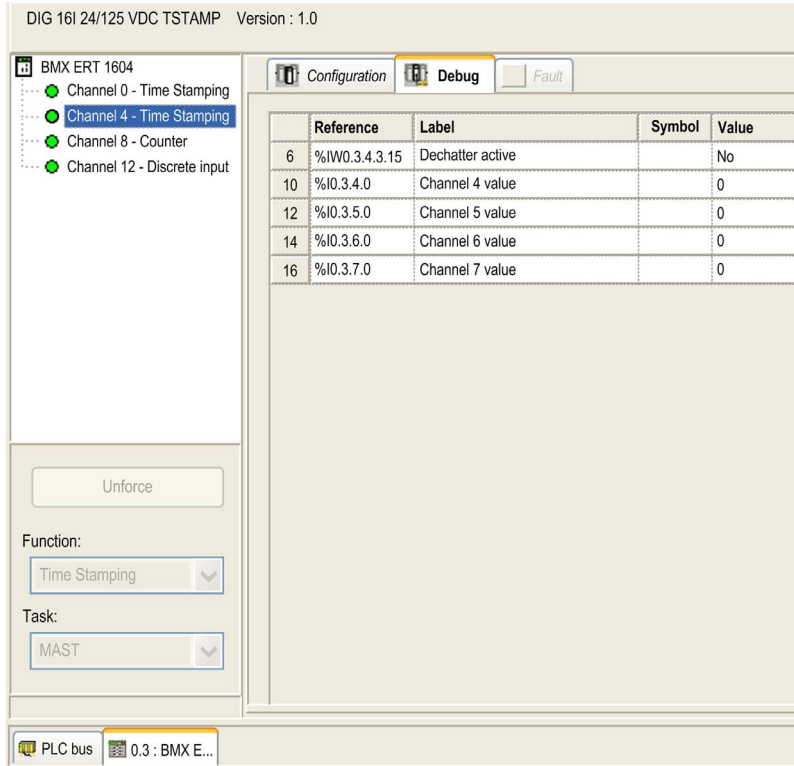

The time stamping parameters for the groups 1, 2, 3 debug page are listed in the following table:

Object	Type	Label	Description
%I $r.m.x$.0	EBOOL	Channel x value	Channel x input value $x = 4, 5, 6, 7$ (group 1) or $8, 9, 10, 11$ (group 2) or $12, 13, 14, 15$ (group 3)
%IW $r.m.x$.3	INT	–	TS_DIAGNOSTIC_FLAGS $x = 4, 8, 12$
%IW $r.m.x$.3.15	BOOL	Dechatter active	<Group Parameter> If any edges discarded by dechatter filter for any channels under this group.

NOTE: $x =$ channel 4, 5, 6, or 7 (group 1); channel 8, 9, 10, or 11 (group 2); channel 12, 13, 14, or 15 (group 3).

Group 1, 2 and 3 Discrete Input Debug Tab

Groups 1, 2 and 3 discrete input debug pages:

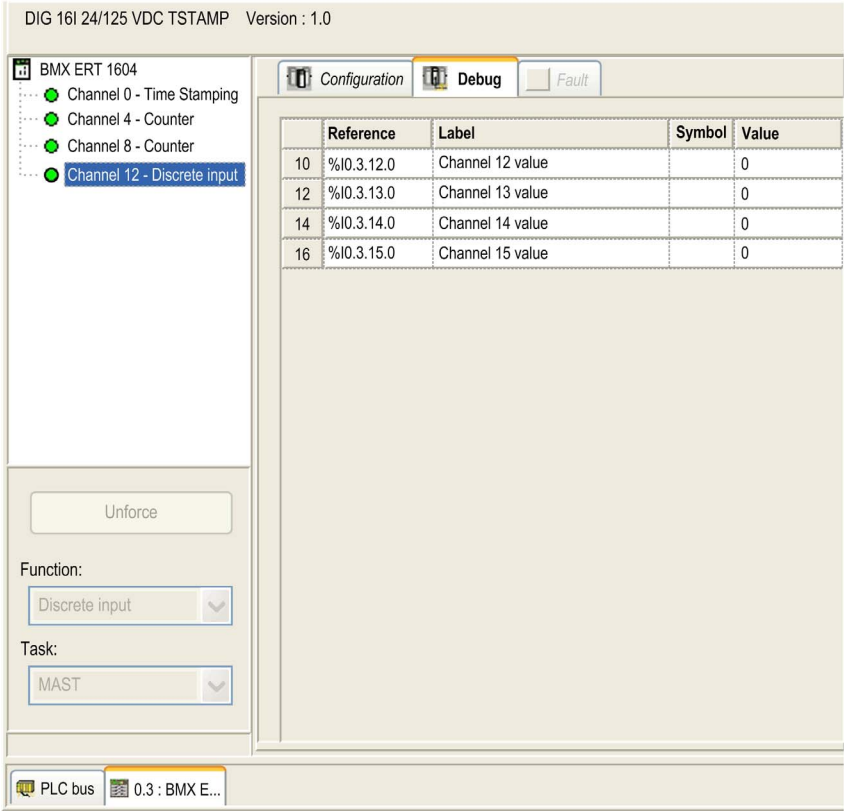

The standard discrete input (without time stamping) parameters for the group 1, 2, 3 debug page are listed in the following table:

Object	Type	Label	Description
%I _{r.m.x} .0	EBOOL	Channel <i>x</i> value	Channel <i>x</i> input value

NOTE: *x* = channel 4, 5, 6, or 7 (group 1); channel 8, 9, 10, or 11 (group 2); channel 12, 13, 14, or 15 (group 3).

Group 1, 2 and 3 Counter Debug Tab

Groups 1, 2 and 3 counter debug pages:

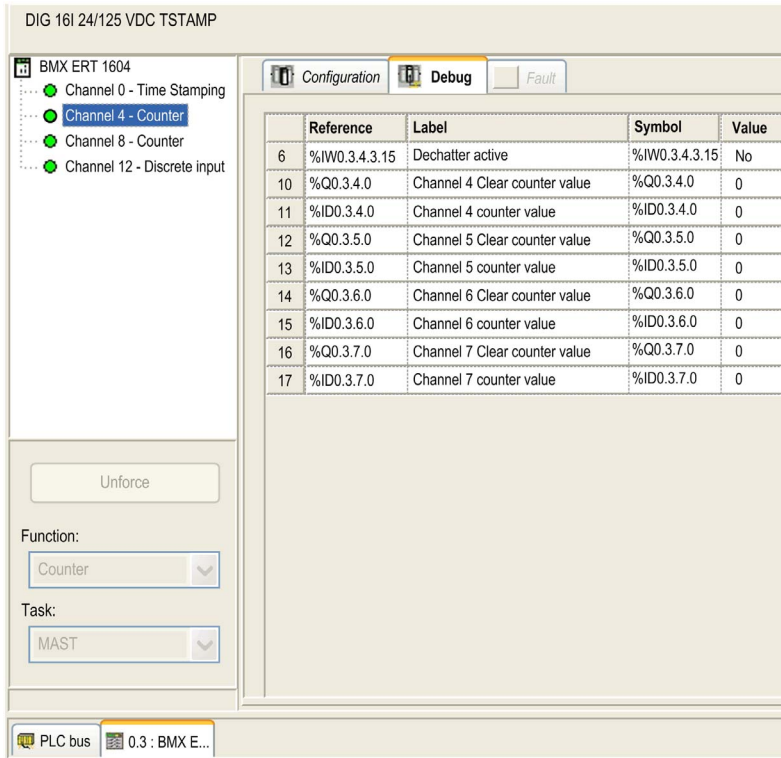

The parameters for group 1, 2, 3 debug page for counter is listed in the following table:

Object	Type	Label	Description
%IDr.m.x.0	DINT	Channel x counter value	Channel x counter value x = 4, 5, 6, 7 (group 1) or 8, 9, 10, 11 (group 2) or 12, 13, 14, 15 (group 3)
%Qr.m.x.0	EBOOL	Channel x clear counter value	Channel x clear counter value
%IW r.m.x.3	INT	–	TS_DIAGNOSTIC_FLAGS x = 4, 8, 12
%IW r.m.x.3.15	BOOL	Dechatter active	<Group Parameter> If any edges discarded by dechatter filter for any channels under this group.

NOTE: x = channel 4, 5, 6, or 7 (group 1); channel 8, 9, 10, or 11 (group 2); channel 12, 13, 14, or 15 (group 3).

Section 6.3

Configuration Parameters for Channels

Overview

This section describes the configuration parameters for the module, each of its groups, and each channel in the groups.

What Is in This Section?

This section contains the following topics:

Topic	Page
Main Function Configuration	104
Configuration for Group 0 Time Stamping	106
Configuration for Group 1, 2, 3 Time Stamping	109
Configuration for Group 1, 2, 3 Discrete Input Without Time Stamping	111
Configuring Group 1, 2, 3 for Counters	113

Main Function Configuration

Configuration

The following figure shows the main function configurations:

The screenshot displays the configuration interface for the BMXERT 1604 module. At the top, the module name 'BMX ERT 1604' and a short description 'DIG 16I 24/125 VDC TSTAMP' are shown. Below this, a tree view lists four channel groups: Channel 0 - Time stamping, Channel 4 - Discrete input, Channel 8 - Counter, and Channel 12 - Time stamping. A 'Configuration' tab is active, showing a table with columns for 'Label' and 'Symbol'. The table lists various parameters for each channel, such as 'Channel 0 chatter count', 'Channel 0 chatter time', 'Channel 1 used', 'Channel 1 edge', 'Channel 1 debounce time', 'Channel 1 chatter count', 'Channel 1 chatter time', 'Channel 2 used', 'Channel 2 edge', 'Channel 2 debounce time', 'Channel 3 used', 'Channel 3 edge', 'Channel 3 debounce time', and 'Channel 3 chatter count'. A 'Function' dropdown menu is visible, with 'Time stamping' selected. A callout box identifies the four channel groups: Group 0: Channel 0-3, Group 1: Channel 4-7, Group 2: Channel 8-11, and Group 3: Channel 12-15. Another callout box points to the 'Main functions' section of the table.

Label	Symbol
8	Channel 0 chatter count
9	Channel 0 chatter time
10	Channel 1 used
11	Channel 1 edge
12	Channel 1 debounce time
13	Channel 1 chatter count
14	Channel 1 chatter time
15	Channel 2 used
16	Channel 2 edge
17	Channel 2 debounce time
18	
19	
20	Channel 3 used
21	Channel 3 edge
22	Channel 3 debounce time
23	Channel 3 chatter count

For groups 1, 2 and 3, select a function:

- Counter
- Discrete input (without time stamping)
- Time stamping: discrete input with time stamping

Input group 0 cannot be reconfigured. These inputs always function as discrete input with time stamping.

For all the functions, the BMXERT1604T/H module only provides MAST **T**ask option.

The image shows a configuration window with a light beige background. It contains two dropdown menus. The first dropdown is labeled 'Function:' and has 'Time stamping' selected. The second dropdown is labeled 'Task:' and has 'MAST' selected. Both dropdowns have a small blue arrow icon on the right side.

Configuration for Group 0 Time Stamping

Parameters Description

Group 0 parameters:

DIG 16I 24/125 VDC TSTAMP

BMX ERT 1604

- Channel 0 - Time Stamping
- Channel 4 - Time Stamping
- Channel 8 - Time Stamping
- Channel 12 - Time Stamping

Configuration

	Label	Symbol	Value	Unit
0	Supply Monitoring		Enable	
1	Rated Voltage		24 VDC	
2	Clock SYNC source		IRIG-B/External Clock	
3	Debounce filter type		Steady state	
4	Dechatter filter		Disable	
5	Channel 0 used		Enable	
6	Channel 0 edge		Both edges	
7	Channel 0 debounce time		1	ms
8	Channel 0 chatter count		255	
9	Channel 0 chatter time		255	100 ms
10	Channel 1 used		Enable	
11	Channel 1 edge		Both edges	
12	Channel 1 debounce time		1	ms
13	Channel 1 chatter count		255	
14	Channel 1 chatter time		255	100 ms
15	Channel 2 used		Enable	
16	Channel 2 edge		Both edges	
17	Channel 2 debounce time		1	ms
18	Channel 2 chatter count		255	
19	Channel 2 chatter time		255	100 ms
20	Channel 3 used		Enable	
21	Channel 3 edge		Both edges	
22	Channel 3 debounce time		1	ms
23	Channel 3 chatter count		255	
24	Channel 3 chatter time		255	100 ms

Function: Time Stamping

Task: MAST

PLC bus 0.3 : BMX E...

Parameters description:

Label		Input Type	Value
Function for group 0		Fixed	Value 2: Time stamping
Module Parameters	Supply monitoring	Option	Value 0: Disable, supply monitoring Value 1: Enable, supply monitoring (default)
	Rated voltage	Option	Value 0: 24 Vdc (default) Value 1: 48/60 Vdc Value 2: 110/125 Vdc
	Clock SYNC source	Option	Value 1: Free Running/Internal Clock Value 2: DCF77/External Clock Value 3: IRIG-B/External Clock (default) Value 4: CPU/CRA Head External Clock (only for BMXERT1604.2 Hardware Catalog device)
Group Parameters	Debounce filter type	Option	Debounce filter (<i>see page 21</i>) Value 0: Steady state, a signal change is only registered if the polarity change remains stable longer than the filter time (each new change resets the filter time) (default) Value 1: Integrating, a signal change is only registered if the time integral of the input signal reaches the programmed filter time taking any polarity change into account
	Dechatter filter	Option	Dechatter filter (<i>see page 25</i>) Value 0: Disable, chatter time and chatter count are deactivated (default) Value 1: Enable, chatter filter for event and counter input
Channel <i>x</i> Parameters (<i>x</i> = 0...3)	Channel <i>x</i> used	Option	Value 0: Enable (default) Value 1: Disable, impedes processing of input data for the input. If disabled, it remains always 0
	Channel <i>x</i> edge	Option	Value 0: Both edges (default) Value 1: Rising edge Value 2: Falling edge
	Channel <i>x</i> debounce time	Input	Debounce time 0...255 ms (default = 1) 0 = Without internal SW delay Unit: ms
	Channel <i>x</i> chatter count	Input	Chatter number 1...255 for event/counter input (default = 1)
	Channel <i>x</i> chatter time	Input	Chatter time duration 1...255 x 100 ms (default = 1) Unit: 100 ms

The BMXERT1604.2 module is configured for group 0 time stamping as previously described, with the additional new feature, **CPU/CRA Head/External Clock** The value of this clock source selection is 3.

The BMXERT1604.2 module can be configured with Control Expert 14.1 or later.

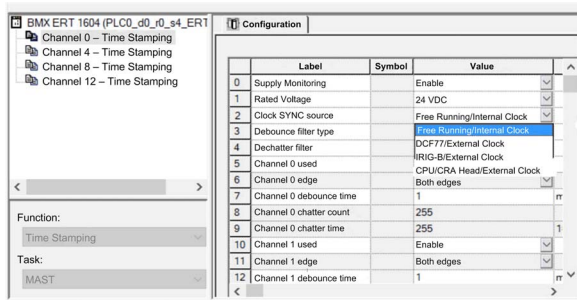

Configuration for Group 1, 2, 3 Time Stamping

Parameters description

Group 1, 2 and 3 time stamping parameters:

DIG 16I 24/125 VDC TSTAMP

BMX ERT 1604

- Channel 0 - Time Stamping
- Channel 4 - Time Stamping**
- Channel 8 - Counter
- Channel 12 - Discrete input

Configuration

	Label	Symbol	Value	Unit
0	Debounce filter type		Steady state	
1	Dechatter filter		Disable	
2	Channel 4 used		Enable	
3	Channel 4 edge		Both edges	
4	Channel 4 debounce time		1	ms
5	Channel 4 chatter count		255	
6	Channel 4 chatter time		255	100 ms
7	Channel 5 used		Enable	
8	Channel 5 edge		Both edges	
9	Channel 5 debounce time		1	ms
10	Channel 5 chatter count		255	
11	Channel 5 chatter time		255	100 ms
12	Channel 6 used		Enable	
13	Channel 6 edge		Both edges	
14	Channel 6 debounce time		1	ms
15	Channel 6 chatter count		255	
16	Channel 6 chatter time		255	100 ms
17	Channel 7 used		Enable	
18	Channel 7 edge		Both edges	
19	Channel 7 debounce time		1	ms
20	Channel 7 chatter count		255	
21	Channel 7 chatter time		255	100 ms

Function: Time Stamping

Task: MAST

PLC bus 0.3 : BMX E...

Parameters description:

Label		Input Type	Value
Function for group x ($x = 4, 8, 12$)		Option	Value 0: Discrete input Value 1: Counter Value 2: Time stamping (default)
Group x Parameters ($x = 4, 8, 12$)	Debounce filter type	Option	Debounce filter (<i>see page 21</i>) Value 0: Steady state, a signal change is only registered if the polarity change remains stable for longer than the filter time (each new change resets the filter time) (default) Value 1: Integrating, a signal change is only registered if the time integral of the input signal reaches the programmed filter time taking any polarity change into account
	Dechatter filter	Option	Dechatter filter (<i>see page 25</i>) Value 0: Disable, chatter time and chatter count are deactivated (default) Value 1: Enable, chatter filter for event and counter input
Channel x Parameters ($x = 4...15$)	Channel x used	Option	Value 0: Enable (default) Value 1: Disable, impedes processing of input data for the input. If disabled, remains always 0.
	Channel x edge	Option	Value 0: Both edges (default) Value 1: Rising edge Value 2: Falling edge
	Channel x debounce time	Input	Debounce time 0...255 ms (default = 1) Value 0: Without internal SW delay Units: ms
	Channel x chatter count	Input	Chatter number 1...255 for event/counter input (default = 1)
	Channel x chatter time	Input	Chatter filter time duration 1...255 x 100 ms (default = 1) Units: 100 ms

Configuration for Group 1, 2, 3 Discrete Input Without Time Stamping

Parameters Description

Group 1, 2 and 3 discrete input parameters:

DIG 16I 24/125 VDC TSTAMP

BMX ERT 1604

- Channel 0 - Time Stamping
- Channel 4 - Time Stamping
- Channel 8 - Counter
- Channel 12 - Discrete input

Configuration

	Label	Symbol	Value	Unit
0	Debounce filter type		Steady state	
1	Channel 12 used		Enable	
2	Channel 12 debounce time		1	ms
3	Channel 13 used		Enable	
4	Channel 13 debounce time		1	ms
5	Channel 14 used		Enable	
6	Channel 14 debounce time		1	ms
7	Channel 15 used		Enable	
8	Channel 15 debounce time		1	ms

Function: Discrete input

Task: MAST

PLC bus 0.3 : BMX E...

Parameters description:

Label		Input Type	Value
Function for group x ($x = 4, 8, 12$)		Option	Value 0: Discrete input (chosen) Value 1: Counter Value 2: Time stamping
Group x Parameters ($x = 4, 8, 12$)	Debounce filter type	Option	Debounce filter (<i>see page 21</i>) Value 0: Steady state, a signal change is only registered if the polarity change remains stable for longer than the filter time (each new change resets the filter time) (default) Value 1: Integrating, a signal change is only registered if the time integral of the input signal reaches the programmed filter time taking any polarity change into account
Channel x Parameters ($x = 4...15$)	Channel x used	Option	Value 0: Enable (default) Value 1: Disable, impedes processing of input data for the input. If disabled, remains always 0.
	Channel x debounce time	Input	Debounce time 0...255 ms (default = 1) Value 0: Without internal SW delay Units: ms

Configuring Group 1, 2, 3 for Counters

Parameters Description

Group 1, 2 and 3 counters parameters:

DIG 16I 24/125 VDC TSTAMP

BMX ERT 1604

- Channel 0 - Time Stamping
- Channel 4 - Time Stamping
- Channel 8 - Counter
- Channel 12 - Discrete input

Configuration

	Label	Symbol	Value	Unit
0	Debounce filter type		Steady state	
1	Dechatter filter		Disable	
2	Channel 8 used		Enable	
3	Channel 8 edge		Both edges	
4	Channel 8 debounce time		1	ms
5	Channel 8 chatter count		255	
6	Channel 8 chatter time		255	100 ms
7	Channel 9 used		Enable	
8	Channel 9 edge		Both edges	
9	Channel 9 debounce time		1	ms
10	Channel 9 chatter count		255	
11	Channel 9 chatter time		255	100 ms
12	Channel 10 used		Enable	
13	Channel 10 edge		Both edges	
14	Channel 10 debounce time		1	ms
15	Channel 10 chatter count		255	
16	Channel 10 chatter time		255	100 ms
17	Channel 11 used		Enable	
18	Channel 11 edge		Both edges	
19	Channel 11 debounce time		1	ms
20	Channel 11 chatter count		255	
21	Channel 11 chatter time		255	100 ms

Function: Counter

Task: MAST

PLC bus 0.3 : BMX E...

Parameters description:

Label		Input Type	Value
Function for group x ($x = 4, 8, 12$)		Option	Value 0: Discrete input Value 1: Counter (chosen) Value 2: Time stamping
Group x Parameters ($x = 4, 8, 12$)	Debounce filter type	Option	Debounce filter (<i>see page 21</i>) Value 0: Steady state, a signal change is only registered if the polarity change remains stable for longer than the filter time (each new change resets the filter time) (default) Value 1: Integrating, a signal change is only registered if the time integral of the input signal reaches the programmed filter time taking any polarity change into account
	Dechatter filter	Option	Dechatter filter (<i>see page 25</i>) Value 0: Disable, chatter time and chatter count are deactivated (default) Value 1: Enable, chatter filter for event and counter input
Channel x Parameters ($x = 4...15$)	Channel x used	Option	Value 0: Enable (default) Value 1: Disable, impedes processing of input data for the input. If disabled, remains always 0.
	Channel x edge	Option	Value 0: Both edges (default) Value 1: Rising edge Value 2: Falling edge
	Channel x debounce time	Input	Debounce time 0...255 ms (default =1) Value 0: Without internal SW delay Unit: ms
	Channel x chatter count	Input	Chatter number 1...255 for event/counter input (default = 1)
	Channel x chatter time	Input	Chatter filter time duration 1...255 x 100 ms (default =1) Unit: 100 ms

Section 6.4

Configuration in Project Settings

Time and Mode Setting

Time Zone and DST Setting

The external time receivers provide the local time format (year/month/day/minute/second) according to the country. The offsets for daylight saving time (DST) are different for different countries or zones.

The BMXERT1604T/H module converts the local time to the standard time format which is specified in IEC 61850 (ms from the UTC epoch of 1970-01-01 00:00:00:000). You must set the correct time zone and DST information in the Control Expert interface.

After the application is created in Control Expert, click **Tools** → **Project Settings** to display the **Time** tab as shown in the following figure.

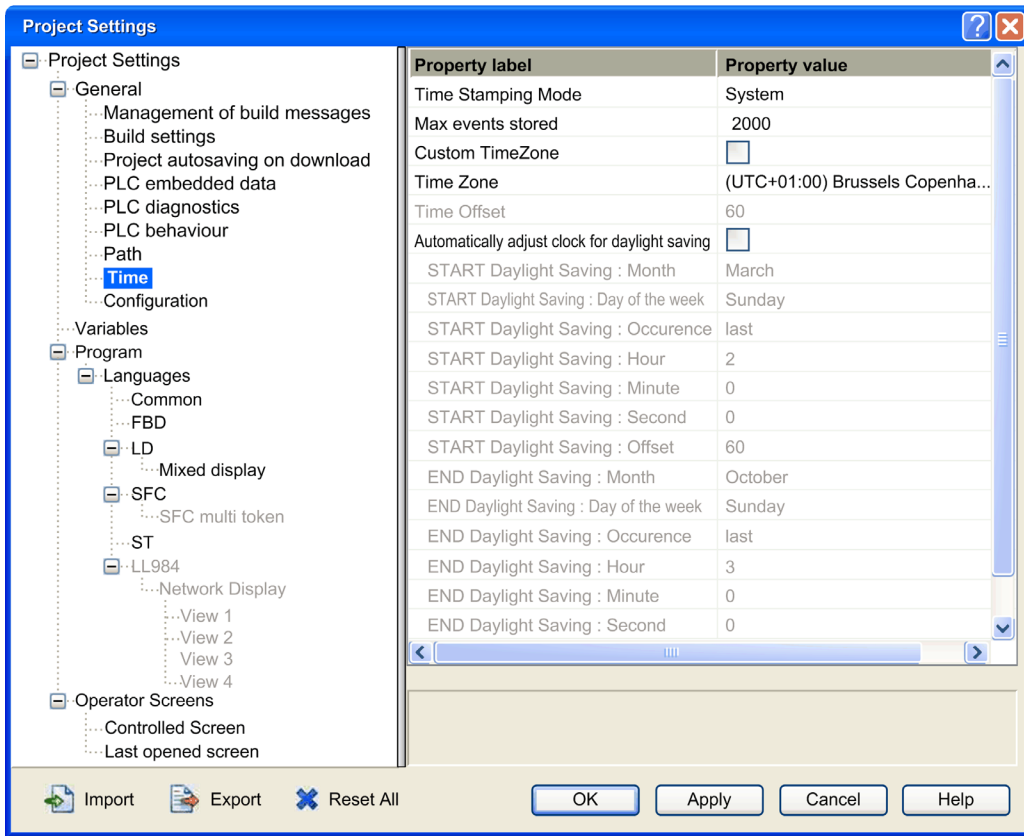

You can select the required time zone by using this interface.

If the listed time zone options do not meet your requirements, the **Time Offset** can be used to set the minutes offset from UTC. To enable this function, check the **Custom Timezone** box.

NOTE: The daylight saving time configuration in the **Project Settings** window is not applicable to the BMXERT1604T/H module. The BMXERT1604T/H module always gets the daylight saving time to standard time switch information from the external clock (IRIG-B or DCF77) regardless of the DST settings in the **Project Settings** window.

An IRIG-B external clock must support IEEE1344 or IEEE C37.118 standard extension definition for DST information in order to maintain time accuracy during the switch between daylight saving time and standard time.

Solution Mode Setting

The module configuration of solution mode option for BMXERT1604T/H is done by the **Time Stamping Mode** option in previous interface. The available options are system and applicative.

The solution mode (time stamping mode) option must be selected according to the customer use case:

System: When OPC (OFS by Schneider for example) is used to communicate with the SCADA.

Applicative (default): When Modbus TCP is used to communicate with the SCADA.

Chapter 7

IODDTs and Languages Objects for the BMXERT1604T/H

Overview

This chapter describes the languages objects for the BMXERT1604T/H module.

What Is in This Chapter?

This chapter contains the following topics:

Topic	Page
Introduction of Language Objects	120
IODDTs	121
Details of the Language Objects of the IODDT of Type T_GEN_MOD	124
Language Objects for Channels	125

Introduction of Language Objects

Language Object Types

Each IODDT contains a set of language objects allowing its operation to be controlled and checked.

There are two types of language objects:

- **Implicit Exchange Objects:** These objects are automatically exchanged on each cycle revolution of the task associated with the module. They correspond to inputs/outputs of the module (measurement results, information and commands).
- **Explicit Exchange Objects:** These objects are exchanged on the application's request, using explicit exchange instructions.

IODDTs

Overview

The IODDTs are predefined and contain language objects of inputs/outputs belonging to the channel of the module.

The BMXERT1604T/H module has the following associated IODDTs:

- T_ERT_CNT: For channels configured as counter
- T_ERT_TS_MOD: For channel 0 with time stamping function (with module status bits included)
- T_ERT_TS: For channels 1...15 which are configured as time stamping
- T_DIS_IN_GEN: For channels configured as discrete input or channels 1...15 configured as time stamping

As any Modicon X80 module, the BMXERT1604T/H module also has a T_GEN_MOD (*see page 124*) IODDT associated.

T_ERT_CNT, T_ERT_TS_MOD, and T_ERT_TS are specific IODDT for BMXERT1604T/H module while T_DIS_IN_GEN is a generic IODDT for all discrete input.

T_ERT_CNT

The following table shows the meaning of T_ERT_CNT IODDT:

Standard Symbol	Type	Access	Meaning	Language Object
CH_ERROR	BOOL	R	Channel error	%lr.m.c.ERR
CNT_CURRENT_VAL	UDINT	R	Current counting value (Not usable for channel [0..3])	%lDr.m.c.0
CLR_CNT	EBOOL	R/W	Clear counter (Not usable for channel [0..3])	%Qr.m.c.0
DECHATTER_ACT	BOOL	R	Dechatter active (information visible on each CNT channel of a group with the same value)	%lWr.m.c.3.15

T_ERT_TS_MOD

The following table shows the meaning of T_ERT_TS_MOD IODDT:

Standard Symbol	Type	Access	Meaning	Language Object
CH_ERROR	BOOL	R	Channel error	%lR.m.c.ERR
VALUE	EBOOL	R	Channel input value	%lR.m.c.0
TIME_STAMP_RECORDS	INT	R	The number of Time Stamp records in module buffer	%lWr.m.c.2
TS_DIAGNOSTIC_FLAGS	INT	R	Diagnostic information about the source time stamped events service	%lWr.m.c.3
TIME_VALID	BOOL	R	Time OK and synchronized	%lWr.m.c.3.0
CLOCK_FAILURE	BOOL	R	Same as ClockFailure indication in the TimeQuality	%lWr.m.c.3.1
CLOCK_NOT_SYNC	BOOL	R	Same as ClockNotSynchronized indication in the TimeQuality	%lWr.m.c.3.2
BUFF_FULL	BOOL	R	Buffer full	%lWr.m.c.3.3
SOE_UNCERTAIN	BOOL	R	Variable to assign an SOE uncertain Event ID	%lWr.m.c.3.7
UMAS_COM_ERR	BOOL	R	UMAS communication error	%lWr.m.c.3.9
DECHATTER_ACT	INT	R	Dechatter active	%lWr.m.c.3.15
TS_BUF_FILLED_PCTAGE	INT	R	Percentage of the buffer filled [0...100]	%lWr.m.c.4
TS_EVENTS_STATE	INT	R	Main state of the TS events service (Debug purpose)	%lWr.m.c.5
CLR_EVENT_BUF	EBOOL	R/W	Clear all event buffer (only for TS applicative)	%Qr.m.c.0
EXCH_STS	INT	R	Exchange status	%MWr.m.c.0
EXCH_IN_PROGR	BOOL	R	Status paramter read in progress	%MWr.m.c.0.0
RECONF_IN_PROGR	BOOL	R	Reconfiguration in progress	%MWr.m.c.0.15
EXCH_RPT	INT	R	Channel report	%MWr.m.c.1
STS_ERR	BOOL	R	Detected error while reading channel status	%MWr.m.c.1.0
RECONF_ERR	BOOL	R	Detected error while reconfiguring the channel	%MWr.m.c.1.15
CH_FLT	INT	R	Standard channel errors	%MWr.m.c.2
EXT_PWS_FLT	BOOL	R	External power supply inoperable error	%MWr.m.c.2.0
INTERNAL_FLT	BOOL	R	Inoperable channel or module missing	%MWr.m.c.2.4
CONF_FLT	BOOL	R	Inoperable hardware or software configuration error	%MWr.m.c.2.5
COM_FLT	BOOL	R	Communication error with PLC	%MWr.m.c.2.6

T_ERT_TS

The following table shows the meaning of T_ERT_TS IODDT:

Standard Symbol	Type	Access	Meaning	Language Object
CH_ERROR	BOOL	R	Channel error	%lr.m.c.ERR
VALUE	EBOOL	R	Channel input value	%lr.m.c.0
DECHATTER_ACT	BOOL	R	Dechatter active (information visible on each TS channel of a group with the same value)	%lWr.m.c.3.15

T_DIS_IN_GEN

The following table shows the meaning of T_DIS_IN_GEN IODDT:

Standard Symbol	Type	Access	Meaning	Language Object
CH_ERROR	BOOL	R	Channel error	%lr.m.c.ERR
VALUE	EBOOL	R	Counter input value	%lr.m.c.0

Details of the Language Objects of the IODDT of Type T_GEN_MOD

Introduction

The Modicon X80 modules have an associated IODDT of type T_GEN_MOD.

Observations

In general, the meaning of the bits is given for bit status 1. In specific cases an explanation is given for each status of the bit.

Some bits are not used.

List of Objects

The table below presents the objects of the IODDT.

Standard Symbol	Type	Access	Meaning	Address
MOD_ERROR	BOOL	R	Module detected error bit	%Ir.m.MOD.ERR
EXCH_STS	INT	R	Module exchange control word	%MWr.m.MOD.0
STS_IN_PROGR	BOOL	R	Reading of status words of the module in progress	%MWr.m.MOD.0.0
EXCH_RPT	INT	R	Exchange report word	%MWr.m.MOD.1
STS_ERR	BOOL	R	Event when reading module status words	%MWr.m.MOD.1.0
MOD_FLT	INT	R	Internal detected errors word of the module	%MWr.m.MOD.2
MOD_FAIL	BOOL	R	module inoperable	%MWr.m.MOD.2.0
CH_FLT	BOOL	R	Inoperative channel(s)	%MWr.m.MOD.2.1
BLK	BOOL	R	Terminal block incorrectly wired	%MWr.m.MOD.2.2
CONF_FLT	BOOL	R	Hardware or software configuration anomaly	%MWr.m.MOD.2.5
NO_MOD	BOOL	R	Module missing or inoperative	%MWr.m.MOD.2.6
EXT_MOD_FLT	BOOL	R	Internal detected errors word of the module (Fipio extension only)	%MWr.m.MOD.2.7
MOD_FAIL_EXT	BOOL	R	Internal detected error, module unserviceable (Fipio extension only)	%MWr.m.MOD.2.8
CH_FLT_EXT	BOOL	R	Inoperative channel(s) (Fipio extension only)	%MWr.m.MOD.2.9
BLK_EXT	BOOL	R	Terminal block incorrectly wired (Fipio extension only)	%MWr.m.MOD.2.10
CONF_FLT_EXT	BOOL	R	Hardware or software configuration anomaly (Fipio extension only)	%MWr.m.MOD.2.13
NO_MOD_EXT	BOOL	R	Module missing or inoperative (Fipio extension only)	%MWr.m.MOD.2.14

Language Objects for Channels

Overview

This section provides the detailed list of channel objects, implicit, and explicit variables for BMXERT1604T/H module.

Channel Objects

The following table shows the meaning of the channel objects:

Standard Symbol	Type	Meaning	Language Object
–	–	Language element of channel level used for explicit exchanges READ_STS	%CHr.m.c
CH_ERROR	BOOL	Channel detected error bit when this bit is at 1.	%Irr.m.c.ERR

Exchange Status: EXCH_STS

The following table shows the meaning of channel exchange status bits from the EXCH_STS channel (%MWr.m.c.0):

Standard Symbol	Type	Meaning	Language Object
STS_IN_PROGR	BIT	If 1, exchange in progress for READ_STS	%MWr.m.c.0.0
RECONF_IN_PROGR	BIT	If 1, indicates a reconfiguration on channel c of the module from the console (modification of the configuration parameters + cold start-up of the channel)	%MWr.m.c.0.15

Exchange Report: EXCH_RPT

The following table shows the meaning of the report bits of the EXCH_RPT channel (%MWr.m.c.1):

Standard Symbol	Type	Meaning	Language Object
STS_ERR	BIT	Report value: <ul style="list-style-type: none"> ● 0: correct exchange ● 1: error while reading channel status 	%MWr.m.c.1.0
RECONF_ERR	BIT	Report value: <ul style="list-style-type: none"> ● 0: correct exchange ● 1: error while reconfiguring the channel 	%MWr.m.c.1.15

Channel Error: CH_FLT

The following table shows the meaning of the report bits of the CH_FLT channel (%MWr.m.c.2):

Standard Symbol	Type	Meaning	Address
EXT_PWS_FLT	BIT	External power supply interruption	%MWr.m.c.2.0
INTERNAL_FLT	BIT	Application detected error	%MWr.m.c.2.4
CONF_FLT	BIT	Hardware or software configuration detected error	%MWr.m.c.2.5
COM_FLT	BIT	Communication error with PLC	%MWr.m.c.2.6

Implicit Input %I

The following table shows the meaning of the implicit inputs (%I):

Standard Symbol	Type	Meaning	Address
Channel <i>x</i> value	EBOOL	Discrete input channel value parameters are for each channel (c = 0...3, 4...7, 8...11, 12...15 in each FB)	%Ir.m.c.0
Channel <i>x</i> counter value	DINT	Counter value (Default: 0 if counter function is not chosen) Parameters are for each channel (c = 0...3, 4...7, 8...11, 12...15 in each FB)	%IDr.m.c.0
TIME_STAMP_RECORDS	INT	The number of Time Stamp records in module buffer	%IWr.m.0.2
TS_DIAGNOSTIC_FLAGS	INT	Indicators providing diagnostic information about the source time stamped events service	%IWr.m.0.3
TIME_VALID	BIT	Time OK and synchronized	%IWr.m.0.3.0
CLOCK_FAILURE	BIT	Same as <code>ClockFailure</code> Indication in the <code>TimeQuality</code>	%IWr.m.0.3.1
CLOCK_NOT_SYNC	BIT	Same as <code>ClockNotSynchronized</code> Indication in the <code>TimeQuality</code>	%IWr.m.0.3.2
BUFF_FULL	BIT	Buffer full	%IWr.m.0.3.3
SOE_UNCERTAIN	BIT	Variable to assign an SOE uncertain Event ID	%IWr.m.0.3.7
UMAS communication error	BIT	UMAS communication detected error	%IWr.m.0.3.9
–	–	(c = 0, 4, 8, 12 in each FB)	%IWr.m.c.3
Dechatter active	BIT	If any edges discarded by dechatter filter for any channels under this group	%IWr.m.c.3.15
TS_BUF_FILLED_PCTAGE	INT	Percentage of the buffer filled [0...100]	%IWr.m.0.4
TS_EVENTS_STATE	INT	Main state of the TS events service (reserved)	%IWr.m.0.5

Implicit Command Objects %Q

The following table shows the meaning of the implicit command objects (%Q):

Standard Symbol	Type	Access	Meaning	Address
Clear event buffer	EBOOL	R/W	Clear event buffer	%Qr.m.0.0
Channel x clear counter value	EBOOL	R/W	Clear channel c counter value Parameters are for each channel (c = 4...15 in each FB)	%Qr.m.c.0

Chapter 8

Device DDT for the BMXERT1604T/H Module

Overview

This chapter provides the Device DDT for the BMXERT1604T/H module.

What Is in This Chapter?

This chapter contains the following topics:

Topic	Page
BMXERT1604T/H Device DDT	130
MOD_FLT Byte Description	132

BMXERT1604T/H Device DDT

Overview

The Device DDT is predefined DDT that describes the I/O language elements of the I/O module. This data type is presented in a structure which provides bits and register view.

This topic describes the structure of the implicit and explicit structures for the BMXERT1604T/H module.

Implicit Device DDTs

The following table shows the structure of the T_M_DIS_ERT implicit device DDT:

Standard Symbol	Type	Access	Meaning
MOD_HEALTH	BOOL	R	Function type <ul style="list-style-type: none"> ● 0: the module has a detected error ● 1: the module is operating correctly
MOD_FLT	BYTE	R	Module internal detected errors byte (<i>see page 132</i>)
ERT_SYNC	T_M_TIME_SYNC_ERT		See detailed structure in the table below.
ERT_CH	ARRAY [0...15] of T_M_DIS_ERT_CH		See detailed structure in the table below

The following table shows the structure of T_M_TIME_SYNC_ERT:

Standard Symbol	Type	Access	Meaning
TS_TIME_STAMP_RECORDS	UINT	R	Current events number in buffer
TS_DIAGNOSTIC_FLAGS	WORD	R	Event buffer flags
TIME_VALID	BOOL	R	Time OK and synchronized
CLOCK_FAILURE	BOOL	R	Same as ClockFailure indication in the TimeQuality
CLOCK_NOT_SYNC	BOOL	R	Same as ClockNotSynchronized in the TimeQuality
BUFF_FULL	BOOL	R	Buffer full
UMAS_COM_ERR	BOOL	R	UMAS communicator
DECHATTER_ACT_0	BOOL	R	Dechatter active on channels 0...3
DECHATTER_ACT_1	BOOL	R	Dechatter active on channels 4...7
DECHATTER_ACT_2	BOOL	R	Dechatter active on channels 8...11
DECHATTER_ACT_3	BOOL	R	Dechatter active on channels 12...15
TS_BUF_FILLED_PCTAGE	BYTE	R	Percentage of the buffer filled (0...100)
TS_EVENTS_STATE	BYTE	R	Main state of the TS events service (debug purpose)

Standard Symbol	Type	Access	Meaning
SOE_UNCERTAIN	BOOL	R	SOE uncertain variable
CLR_EVT_BUF	EBOOL	R/W	Clear event buffer NOTE: Only available for applicative time stamping mode.

The following table shows the structure of T_M_DIS_ERT_CH:

Standard Symbol	Type	Access	Meaning
FCT_TYPE	WORD	R	Function type <ul style="list-style-type: none"> ● 0: Discrete Input ● 1: Counter ● 2: Time Stamping
CH_HEALTH	BOOL	R	Channel health
DIS_VALUE	EBOOL	R	Discrete value
CNT_VALUE	UDINT	R	Counting value for channel [4..15] (Not usable for channel [0..3])
CLR_CNT	EBOOL	R/W	Clear counter value for channel [4..15] (Not usable for channel [0..3])

DDT for Explicit Exchanges

Optional explicit DDT types are proposed in the data editor to support Status or Command data used by explicit exchanges on a channel of an IO module in device DDT data model. Explicit DDT instances are created manually by the user in the data editor and used as Output parameter with the function block managing the explicit exchange (`READ_STS_QX`).

The following table shows the meaning of T_M_DIS_ERT_CH_STS explicit DDT:

Explicit DDT type	Standard Symbol	Type	Access	Meaning
T_M_DIS_ERT_CH_STS	CH_FLT	INT	R	Standard channel errors
	EXT_PWS_FLT	BOOL	R	External power supply error
	INTERNAL_FLT	BOOL	R	Inoperable channel or module missing
	CONF_FLT	BOOL	R	Hardware or software configuration detected error
	COM_FLT	BOOL	R	Communication error with PLC

MOD_FLT Byte Description

MOD_FLT Byte in Device DDT

MOD_FLT byte structure:

Bit	Symbol	Description
0	MOD_FAIL	<ul style="list-style-type: none"> ● 1: Internal detected error or module failure detected. ● 0: No detected error
1	CH_FLT	<ul style="list-style-type: none"> ● 1: Inoperative channels. ● 0: Channels are operative.
2	BLK	<ul style="list-style-type: none"> ● 1: Terminal block detected error. ● 0: No detected error. <p>NOTE: This bit may not be managed.</p>
3	–	<ul style="list-style-type: none"> ● 1: Module in self-test. ● 0: Module not in self-test. <p>NOTE: This bit may not be managed.</p>
4	–	Not used.
5	CONF_FLT	<ul style="list-style-type: none"> ● 1: Hardware or software configuration detected error. ● 0: No detected error.
6	NO_MOD	<ul style="list-style-type: none"> ● 1: Module is missing or inoperative. ● 0: Module is operating. <p>NOTE: This bit is managed only by modules located in a remote rack with a BME CRA 312 10 adapter module. Modules located in the local rack do not manage this bit that remains at 0.</p>
7	–	Not used.

Chapter 9

Firmware Update

What Is in This Chapter?

This chapter contains the following topics:

Topic	Page
Firmware Update with Automation Device Maintenance	134
Module Firmware Update with Unity Loader	135

Firmware Update with Automation Device Maintenance

Overview

The EcoStruxure™ Automation Device Maintenance is a standalone tool that allows and simplifies the firmware update of devices in a plant (single or multiple).

The tool supports the following features:

- Automatic device discovery
- Manual device identification
- Certificate management
- Firmware update for multiple devices simultaneously

NOTE: For a description of the download procedure, refer to the *EcoStruxure™ Automation Device Maintenance, User Guide*.

Module Firmware Update with Unity Loader

Introduction

You can update the firmware of the BMXERT1604T/H by downloading a new firmware version with Unity Loader.

Download the firmware by connecting to any of these modules installed on the rack:

- M580 CPU
- BM•CRA31210 (e)X80 adapter module

Preparation

Before performing the update:

- check that the service (**FTP Service** or **Service Port**) is enabled.
- stop the PLC.
- open Unity Loader on your PC (**Start** → **Programs** → **Schneider Electric** → **Unity Loader**).

WARNING

UNKNOWN OPERATIONAL STATE OF EQUIPMENT

Evaluate operational state of equipment before stopping the PLC.

Failure to follow these instructions can result in death, serious injury, or equipment damage.

NOTE: If you do not stop the PLC before trying to transfer firmware, you are informed by Unity Loader that the PLC must be stopped. After confirming this message, Unity Loader stops the PLC automatically.

Firmware

The firmware file is included in an **.dx* file.

Troubleshooting

If the rack power supply is turned off during the update procedure, the module firmware remains on the version embedded before the update procedure.



A

application areas, *44*

B

BMXERT1604T
 configuration, *85*
 IODDT, *119*
BMXFTB2800, *57*
BMXFTB2820, *57*
BMXXSP0400, *82*
BMXXSP0600, *82*
BMXXSP0800, *82*
BMXXSP1200, *82*

C

certifications, *61*
channel data structure for all modules
 T_GEN_MOD, *124*
configuration
 BMXERT1604 T, *87*
 BMXERT1604T, *85*
 hidden configuration parameters, *87*
 parameters for channels, *87*
 project settings, *87*
 user screen, *87*
configuration parameters for channels
 configuration for group 0 time stamping,
 103
 configuration for group 1, 2, 3 discrete in-
 put without time stamping, *103*
 configuration for group 1, 2, 3 for count-
 ers, *103*
 configuration for group 1, 2, 3 time stamp-
 ing, *103*
 main function configuration, *103*
counter function, *41*

D

debounce filter, *21*
Device DDT, *129*
 T_M_DIS_ERT, *129*
disabling discrete inputs, *19*
discrete input
 debounce filter, *18*
 enable, *18*
 multi-voltage and supply monitor sub-
 functions, *18*
discrete inputs
 disabling, *19*

F

filtering
 integrating, *22*
 steady, *22*
firmware
 update, *134, 135*
 upgrade, *134*
functional overview
 introduction, *11*
 typical application areas, *11*
 user functions, *11*

G

grounding accessories, *82*
 BMXXSP0400, *82*
 BMXXSP0600, *82*
 BMXXSP0800, *82*
 BMXXSP1200, *82*
 STBXSP3010, *82*
 STBXSP3020, *82*
guidelines for the physical installation
 installing the BMXERT1604T/HBM•ERT
 module, *76*

I

- inputs, discrete
 - disabling, *19*
- integrating filtering, *22*
- IODDT, *121*
 - BMXERT1604T, *119*

M

- main functions, *16*
- MOD_FLT, *132*
- module configuration, *90*
- module description
 - diagnosis, *53*
 - field wiring, *53*
 - overview, *53*
 - technical data, *53*
- module overview, *13*

P

- physical installation
 - 28-pin terminal blocks, *75*
 - accessories, *75*
 - BMX ERT 1604 T module, *75*
 - fitting 28-pin terminal blocks, *75*

S

- standards, *61*
- STBXSP3010, *82*
- STBXSP3020, *82*
- steady state filtering, *22*

T

- T_DIS_IN_GEN, *121*
- T_ERT_CNT, *121*
- T_ERT_TS, *121*
- T_ERT_TS_MOD, *121*
- T_GEN_MOD, *124*
- T_M_DIS_ERT, *130*
- T_M_DIS_ERT_CH, *130*
- T_M_TIME_SYNC_ERT, *130*

- terminal blocks, *57*
- time stamping
 - behavior mode, *23*
 - dechatter filter, *23*
 - edge detection, *23*
 - EFB, *23*
 - event storage, *23*
 - time synchronization, *23*
- time zone and DST settings, *115*
- typical applications, *45*

U

- update
 - firmware, *134, 135*
- upgrade
 - firmware, *134*
- user functions
 - counter function, *15*
 - discrete input, *15*
 - introduction, *15*
 - time stamping, *15*
- user screen
 - online mode, *90*
 - overview, *90*