

# Altivar ATV310

Variable speed drives for asynchronous motors and synchronous motors

## User manual

05/2026



380 Vac...460 Vac Three-phase, power rating 0.37 kW to 22 kW (HD)



# Contents

---

Important information	4
Before you begin	5
Documentation structure	9
Steps for setting up (also refer to Quick Start)	10
Setup - Preliminary recommendations	11
Drive& ratings	12
Dimensions and weights	15
Environmental Conditions	17
Nameplate	19
Mounting	20
Wiring	23
Power terminals	29
Control terminals	34
Check list Before Switching On	39
Factory configuration	40
Basic functions	41
Programming	42
Structure of parameter tables	45
Function compatibility table	46
Reference Mode rEF	47
Monitoring mode MOn	48
Configuration mode, ConF	55
Configuration Mode	56
Configuration Mode - Complete menu (FULL)	57
Maintenance	122
Diagnostics and Troubleshooting	124
Application notes	130
Upstream Protective Device	136

# Important information

---

## NOTICE

Read these instructions carefully, and become familiar with the device before trying to install, operate, or maintain it. The following special messages may appear throughout this documentation or on the equipment to warn of potential hazards or to call attention to information that clarifies or simplifies a procedure.



The addition of this symbol to a Danger or Warning safety label indicates that an electrical hazard exists, which will result in personal injury if the instructions are not followed.



This is the safety alert symbol. It is used to alert you to potential injury hazards that exist at this point. Obey all safety messages that follow this symbol to avoid possible injury or death.

## **DANGER**

**DANGER** indicates an imminently hazardous situation, which, if not avoided, **will result** in death or serious injury.

## **WARNING**

**WARNING** indicates a potentially hazardous situation which, if not avoided, **can result** in death, serious injury or equipment damage.

## **CAUTION**

**CAUTION** indicates a potentially hazardous situation which, if not avoided, **can result** in injury or equipment damage.

## **NOTICE**

*Notice*, used without the safety alert symbol, indicates a potentially hazardous situation which, if not avoided, **can result** in equipment damage.

### PLEASE NOTE

The word "drive" as used in this manual refers to the controller of the adjustable speed drive as defined by NEC.

Electrical equipment should be installed, operated, serviced, and maintained only by qualified personnel. No responsibility is assumed by Schneider Electric for any consequences arising out of the use of this product.

© 2026 Schneider Electric. All Rights Reserved.

# Before you begin

Read and understand these instructions before performing any procedure with this drive.

## DANGER

### HAZARD OF ELECTRIC SHOCK, EXPLOSION OR ARC FLASH

- Only appropriately trained persons who are familiar with and fully understand the contents of the present manual and all other pertinent product documentation and who have received all necessary training to recognize and avoid hazards involved are authorized to work on and with this drive system.
- Installation, adjustment, repair and maintenance must be performed by qualified personnel.
- Verify compliance with all local and national electrical code requirements as well as all other applicable regulations with respect to grounding of all equipment.
- Only use properly rated, electrically insulated tools and measuring equipment.
- Do not touch unshielded components or terminals with voltage present.
- Prior to performing any type of work on the drive system, block the motor shaft to prevent rotation.
- Insulate both ends of unused conductors of the motor cable.
- Do not short across the DC bus terminals or the DC bus capacitors or the braking resistor terminals.
- Before performing work on the drive system:
  - Disconnect all power, including external control power that may be present.
  - Place a "Do Not Turn On" label on all power switches.
  - Lock all power switches in the open position.
  - Wait 15minutes to allow the DC bus capacitors to discharge. The DC bus LED is not an indicator of the absence of DC bus voltage that can exceed 800 Vdc.
  - Verify that no other voltage is present in the drive system.
- Before applying voltage to the drive system:
  - Verify that the work has been completed and that the entire installation cannot cause hazards.
  - If the mains input terminals and the motor output terminals have been grounded and short-circuited, remove the ground and the short circuits on the mains input terminals and the motor output terminals.
  - Verify proper grounding of all equipment.
- Verify that all protective equipment such as covers, doors, grids is installed and/or closed.

**Failure to follow these instructions will result in death or serious injury.**

## WARNING

### UNEXPECTED MOVEMENT

Drive systems may perform unexpected movements because of incorrect wiring, incorrect settings, incorrect data or other errors.

- Carefully install the wiring in accordance with the EMC requirements.
- Do not operate the product with unknown or unsuitable settings or data.
- Perform a comprehensive commissioning test.

**Failure to follow these instructions can result in death, serious injury, or equipment damage.**

Damaged products or accessories may cause electric shock or unanticipated equipment operation.

## DANGER

### ELECTRIC SHOCK OR UNANTICIPATED EQUIPMENT OPERATION

Do not use damaged products or accessories.

**Failure to follow these instructions will result in death or serious injury.**

Contact your local Schneider Electric sales office if you detect any damage whatsoever.

## NOTICE

### RISK OF DAMAGE TO THE DRIVE

The drive should be cleaned and maintained on a regular basis when operating in high temperature, humid, greasy, chemical, dusty or vibrating environments to prevent reduced driver lifespan and equipment damage.

**Failure to follow these instructions can result in equipment damage.**

## Before you begin

### **WARNING**

#### **LOSS OF CONTROL**

- The designer of any control scheme must consider the potential failure modes of control paths and, for critical control functions, provide a means to achieve a safe state during and after a path failure. Examples of critical control functions are emergency stop, overtravel stop, power outage, and restart.
- Separate or redundant control paths must be provided for critical control functions.
- System control paths may include communication links. Consideration must be given to the implications of unanticipated transmission delays or failures of the link.
- Observe all accident prevention regulations and local safety guidelines. (a)
- Each implementation of the product must be individually and thoroughly tested for proper operation before being placed into service.

**Failure to follow these instructions can result in death, serious injury or equipment damage.**

a. For USA: Additional information, refer to NEMA ICS 1.1 (latest edition), "Safety Guidelines for the Application, Installation, and Maintenance of Solid State Control" and to NEMA ICS 7.1 (latest edition), "Safety Standards for Construction and Guide for Selection, Installation and Operation of Adjustable Speed Drive Systems."

### **NOTICE**

#### **DESTRUCTION DUE TO INCORRECT MAINS VOLTAGE**

Before switching on and configuring the product, verify that it is approved for the mains voltage.

**Failure to follow these instructions can result in equipment damage.**

This equipment has been designed to operate outside of any hazardous location. Only install this equipment in zones known to be free of a hazardous atmosphere.

### **DANGER**

#### **POTENTIAL FOR EXPLOSION**

Install and use this equipment in non-hazardous locations only.

**Failure to follow these instructions will result in death or serious injury.**

## Before you begin

---

Your application consists of a whole range of different interrelated mechanical, electrical, and electronic components, the drive being just one part of the application. The drive by itself is neither intended to nor capable of providing the entire functionality to meet all safety-related requirements that apply to your application. Depending on the application and the corresponding risk assessment to be conducted by you, a whole variety of additional equipment is required such as, but not limited to, external encoders, external brakes, external monitoring devices, guards, etc.

As a designer/manufacturer of machines, you must be familiar with and observe all standards that apply to your machine. You must conduct a risk assessment and determine the appropriate Performance Level (PL) and/or Safety Integrity Level (SIL) and design and build your machine in compliance with all applicable standards. In doing so, you must consider the interrelation of all components of the machine. In addition, you must provide instructions for use that enable the user of your machine to perform any type of work on and with the machine such as operation and maintenance in a safe manner.

The present document assumes that you are fully aware of all normative standards and requirements that apply to your application. Since the drive cannot provide all safety-related functionality for your entire application, you must ensure that the required Performance Level and/or Safety Integrity Level is reached by installing all necessary additional equipment.

### **WARNING**

#### **INSUFFICIENT PERFORMANCE LEVEL/SAFETY INTEGRITY LEVEL AND/OR UNINTENDED EQUIPMENT OPERATION**

- The designer of any control scheme must consider the potential failure modes of control paths and, for critical control functions, provide a means to achieve a safe state during and after a path failure. Examples of critical control functions are emergency stop, overtravel stop, power outage, and restart.
- Conduct a risk assessment according to EN ISO 12100 and all other standards that apply to your application.
- Use redundant components and/or control paths for all critical control functions identified in your risk assessment.
- If moving loads can result in hazards, for example, slipping or falling loads, operate the drive in closed loop mode.
- Verify that the service life of all individual components used in your application is sufficient for the intended service life of your overall application.
- Perform extensive commissioning tests for all potential error situations to verify the effectiveness of the safety-related functions and monitoring functions implemented, for example, but not limited to, speed monitoring by means of encoders, short circuit monitoring for all connected equipment, correct operation of brakes and guards.
- Perform extensive commissioning tests for all potential error situations to verify that the load can be brought to a safe stop under all conditions.

**Failure to follow these instructions can result in death, serious injury or equipment damage.**

## Before you begin

---

Machines, controllers, and related equipment are usually integrated into networks. Unauthorized persons and malware may gain access to the machine as well as to other devices on the network/fieldbus of the machine and connected networks via insufficiently secure access to software and networks.

### **WARNING**

#### **UNAUTHORIZED ACCESS TO THE MACHINE VIA SOFTWARE AND NETWORKS**

- In your hazard and risk analysis, consider all hazards that result from access to and operation on the network/fieldbus and develop an appropriate cybersecurity concept.
- Verify that the hardware infrastructure and the software infrastructure into which the machine is integrated as well as all organizational measures and rules covering access to this infrastructure consider the results of the hazard and risk analysis and are implemented according to best practices and standards covering IT security and cybersecurity, such as:
  - ISO/IEC 27000 series, ISO/ IEC 15408, IEC 62351, ISA/IEC 62443,
  - NIST Cybersecurity Framework,
  - Information Security Forum - Standard of Good Practice for Information Security,
  - Schneider Electric *Recommended Cybersecurity Best Practices*.
- Verify the effectiveness of your IT security and cybersecurity systems using appropriate, proven methods.

**Failure to follow these instructions can result in death, serious injury or equipment damage.**

### **WARNING**

#### **LOSS OF CONTROL**

Perform a comprehensive commissioning test to verify that communication monitoring properly detects communication interruptions.

**Failure to follow these instructions can result in death, serious injury or equipment damage.**

## Using motors in parallel

Set [Motor control type 309](#) (page 69) to [03](#).

Motor thermal monitoring is no longer provided by the drive.

### **NOTICE**

#### **MOTOR OVERHEATING**

Install external thermal monitoring equipment under the following conditions:

If several motor are connected to the same drive, Install external thermal monitoring equipment for each motor

**Failure to follow these instructions can result in equipment damage.**

# Documentation structure

---

The following Altivar 310 technical documents are available on the Schneider Electric website ([www.schneider-electric.cn](http://www.schneider-electric.cn)).

## **ATV310 Quick Start Guide [EAV96127 \(Chinese\)](#), [EAV96135 \(English\)](#)**

The Quick Start Guide is delivered with the drive and describes how to wire and configure the drive to start motor quickly and simply for simple applications.

## **ATV310 Complete Parameters list [EAV96129 \(Chinese\)](#), [EAV96136 \(English\)](#)**

This manual gives the full parameter list of the drive in English and in Chinese.

## **ATV310 User manual [EAV94276 \(Chinese\)](#), [EAV94277 \(English\)](#)**

This manual describes how to install, program and operate the drive.

## **ATV310 Modbus Communication manual ([EAV94278](#))**

This manual describes the assembly, connection to the bus or network, signaling, diagnostics, and configuration of the communication-specific parameters via the 7 segment LED display.

It also describes the communication services of the Modbus protocol.

This manual includes all Modbus addresses. It explains the operating mode specific to communication (state chart).

## **ATV310 Modbus parameters description file ([EAV94279](#))**

All the parameters are grouped together in an Excel file with the following data:

- Code
- Name
- Modbus Addresses
- Category
- Read/write access
- Type: signed numerical, unsigned numerical, etc.
- Unit
- Factory setting
- Minimum value
- Maximum value
- Display on the 7-segment integrated display terminal
- Relevant menu
- This file offers the option of sorting and arranging the data according to any criterion chosen by the user.

## **CS-Best-Practices-2019-340 [7EN52-0390 \(English\)](#)**

Recommended Cybersecurity Best Practices

## 1. Receive and inspect the drive

- Check that the part number printed on the label is the same as that on the purchase order.
- Remove the ATV310 from its packaging and check that it has not been damaged in transit.

## 2. Check the line voltage

- Check that the line voltage is compatible with the voltage range of the drive (page [12](#)).

## 3. Mount the drive

- Mount the drive in accordance with the instructions in this document (page [21](#)).
- Install any options required.

## 4. Wire the drive (page [23](#))

- Connect the motor, ensuring that its connections correspond to the voltage.
- Connect the line supply, after making sure that the power is off.
- Connect the control part.

## 5. Configure the drive (page [40](#))

- Apply input power to the drive, but do not give a run command.
- Set the motor parameters (in Conf mode) only if the factory configuration of the drive is not suitable.
- Perform auto-tuning.

## 6. Start

Steps 2 to 4 must be performed with the power off.



## Prior to switching on the drive

### **WARNING**

#### **UNANTICIPATED EQUIPMENT OPERATION**

Before switching on the device, verify that no unintended signals can be applied to the digital inputs that could cause unintended movements.

**Failure to follow these instructions can result in death, serious injury, or equipment damage.**

## Using the drive with motor having a different size

The motor could have a different rating to the drive. In case of smaller motors, there is no specific calculation. The estimated motor current has to be set at **Motor thermal current 604.0** parameter (page 114). In case of large motors (with up to 2 times the capacity of the drive), e.g., using a 4 kW motor in conjunction with a 2.2 kW drive, motor current and actual motor power must not exceed the rated current and power of the drive.

## Line contactor

### **NOTICE**

#### **RISK OF DAMAGE TO THE DRIVE**

Do not switch on the drive at intervals of less than 60 s.

**Failure to follow these instructions can result in equipment damage.**

## Use with a smaller rated motor or without a motor

- In factory settings mode, **Output Phase loss 605** (page 114) is active (**605 = 01**). To check the drive in a test or maintenance environment without having to switch to a motor with the same rating as the drive (particularly useful in the case of high power drives), deactivate **Output Phase loss 605** (**605 = 00**).
- In Motor control menu **300** - set **Motor control type 309** (page 69) to **03**.

### **NOTICE**

#### **MOTOR OVERHEATING**

Install external thermal monitoring equipment if a motor with a nominal current of less than 20% of the nominal current of the drive is connected.

**Failure to follow these instructions can result in equipment damage.**

# Drive& ratings

Three-phase supply voltage: 380 V...460 V 50/60 Hz

For three Phase Output 380 V...460 V asynchronous motors

Motor	Line supply (input)			Drive (output)			EMC category (5)	Reference	Frame Size
	Power indicated on plate (1)	Maximum line current (4)	Apparent power	Nominal Current In	Max. transient current for 60 s	Power dissipated at nominal current			
HD: Heavy duty (2) ND: Normal duty (3)	at 380 V	at 460 V							
	kW	A	A	kVA	A	A	W		
HD	0.37	2.1	1.8	1.4	1.5	2.3	22.7	ATV310H037N4●	1
HD	0.75	3.5	3.1	2.5	2.3	3.5	34.1	ATV310H075N4●	1
HD	1.5	6.5	5.4	4.3	4.1	6.2	60.4	ATV310HU15N4●	2
HD	2.2	8.8	7.2	5.7	5.5	8.3	75.5	ATV310HU22N4●	2
HD	3	11.1	9.2	7.3	7.1	10.7	90.8	ATV310HU30N4●	3
ND	4	14.2	11.6	9.3	8.9	9.8	120.4		
HD	4	13.7	11.4	9.1	9.5	14.3	115.1	ATV310HU40N4●	3
ND	5.5	18.0	14.9	11.8	12.1	13.3	158.3		
HD	5.5	21.3	14.3	11.4	12.6	18.9	162.4	ATV310HU55N4●	3
ND	7.5	23.0	19.0	15.1	16	17.6	201.9		
HD	7.5	26.6	22.4	17.8	17	25.5	241.2	ATV310HU75N4●	4
ND	11	29.5	24.8	19.4	22.8	25.1	317.8		
HD	11	36.1	30.4	24.2	24	36.0	337.1	ATV310HD11N4●	4
ND	15	38.6	32.5	25.4	30	33.0	407.0		
HD	15	46.5	38.5	30.7	33	49.5	416.0	ATV310HD15N4●	5
ND	18.5	46.6	38.8	31.2	36	39.6	451.7		
HD	18.5	55.3	45.8	36.5	39	58.5	515.9	ATV310HD18N4●	5
ND	22	54.1	45.1	35.7	43	47.3	539.4		
HD	22	64.2	53.2	46.2	46	69	568.8	ATV310HD22N4●	6
ND	30	71.2	59.2	47	60	66	735.6		
HD	15	46.5	38.5	30.7	33	49.5	424.4	C3 ATV310HD15N4●F	5
ND	18.5	46.6	38.8	31.2	36	39.6	460.2		
HD	18.5	55.3	45.8	36.5	39	58.5	527.8	C3 ATV310HD18N4●F	5
ND	22	54.1	45.1	35.7	43	47.3	550.9		
HD	22	64.2	53.2	46.2	46	69	593.5	C3 ATV310HD22N4●F	6
ND	30	71.2	59.2	47	60	66	765.9		

(1) These power ratings are for a Switching frequency range of 4 kHz, in continuous operation. The Switching frequency range is adjustable from 2 to 12 kHz.

Above 4 kHz, the drive will reduce the Switching frequency range if an excessive temperature rise occurs. Derating should be applied to the nominal drive current if continuous operation above 4 kHz is required:

- 10% derating for 8 kHz
- 20% derating for 12 kHz

(2) Values given for applications requiring significant overload (up to 150% for 60 s).

(3) Values given for applications requiring slight overload (up to 110% for 60 s).

(4) Line current network requirements:

- ≤ 4 kW, network short circuit current  $I_{sc} \leq 5$  kA
- > 4 kW, network short circuit current  $I_{sc} : \leq 22$  kA for Heavy duty, ≤ 5 kA for Normal duty

(5) • Altivar ATV310●●N4●F drives with integrated EMC filter fulfill IEC/EN61800-3 with 25 m/82 ft shielded motor cable for CE, and with 5m/16.4ft shielded motor cable for RE.

- Altivar ATV310●●N4● drives without integrated EMC filter, need to add external EMC filter to fulfill the IEC/EN 61800-3 standard. Refer to External EMC filter selection table page [14](#).

## NOTICE

### RISK OF DAMAGE TO THE DRIVE

The drive will be damaged if it operates above the nominal current ( $I_n$ ) for an extended period of time.

Operating time should not exceed 60 s at  $1.5 \times I_n$ .

**Failure to follow these instructions can result in equipment damage.**

# Drive& ratings

Three-phase supply voltage: 380 V...460 V 50/60 Hz

For three Phase Output 380 V...460 V synchronous motors

Motor	Line supply (input)			Drive (output)			EMC category (5)	Reference	Frame Size
	Power indicated on plate (1)	Maximum line current (4)	Apparent power	Nominal Current In	Max. transient current for 60 s	Power dissipated at nominal current			
HD: Heavy duty (2) ND: Normal duty (3)	at 380 V	at 460 V							
	<b>kW</b>	<b>A</b>	<b>A</b>	<b>kVA</b>	<b>A</b>	<b>A</b>	<b>W</b>		
HD	0.37	2.1	1.8	1.4	1.5	2.3	22.7	ATV310H037N4S	1
HD	0.75	3.5	3.1	2.5	2.3	3.5	34.1	ATV310H075N4S	1
HD	1.5	6.5	5.4	4.3	4.1	6.2	60.4	ATV310HU15N4S	2
HD	2.2	8.8	7.2	5.7	5.5	8.3	75.5	ATV310HU22N4S	2
HD	3	11.1	9.2	7.3	7.1	10.7	90.8		
ND	4	14.2	11.6	9.3	8.9	9.8	120.4		
HD	4	13.7	11.4	9.1	9.5	14.3	115.1		
ND	5.5	18.0	14.9	11.8	12.1	13.3	158.3	ATV310HU40N4S	3
HD	5.5	21.3	14.3	11.4	12.6	18.9	162.4		
ND	7.5	23.0	19.0	15.1	16	17.6	201.9	ATV310HU55N4S	3
HD	7.5	26.6	22.4	17.8	17	25.5	241.2		
ND	11	29.5	24.8	19.4	22.8	25.1	317.8	ATV310HU75N4S	4
HD	11	36.1	30.4	24.2	24	36.0	337.1		
ND	15	38.6	32.5	25.4	30	33.0	407.0	ATV310HD11N4S	4

(1) These power ratings are for a Switching frequency range of 4 kHz, in continuous operation. The Switching frequency range is adjustable from 2 to 12 kHz.

Above 4 kHz, the drive will reduce the Switching frequency range if an excessive temperature rise occurs. Derating should be applied to the nominal drive current if continuous operation above 4 kHz is required:

- 10% derating for 8 kHz
- 20% derating for 12 kHz

(2) Values given for applications requiring significant overload (up to 150% for 60 s).

(3) Values given for applications requiring slight overload (up to 110% for 60 s).

(4) Line current network requirements:

- ≤ 4 kW, network short circuit current  $I_{sc} \leq 5$  kA
- > 4 kW, network short circuit current  $I_{sc} : \leq 22$  kA for Heavy duty, ≤ 5 kA for Normal duty

(5) Altivar ATV310...N4S drives without integrated EMC filter, need to add external EMC filter to fulfill the IEC/EN 61800-3 standard.

Refer to External EMC filter selection table page [14](#).

## NOTICE

### RISK OF DAMAGE TO THE DRIVE

The drive will be damaged if it operates above the nominal current ( $I_n$ ) for an extended period of time. Operating time should not exceed 60 s at  $1.5 \times I_n$ .

**Failure to follow these instructions can result in equipment damage.**

## External EMC filter selection table

When the drive is without integrated EMC filter, the following external EMC filter is mandatory required to fulfill the IEC/EN 61800-3 C3 category.

Drive Reference	380V line input current (A)		EMC filter reference	EN 61800-3	
	HD	ND		Conduct emission	Radiated emission
ATV310H037N4•	2.1	N/A	VW3A4422	C3 max shielded cable 25m	C3 max shielded cable 5m
ATV310H075N4•	3.5	N/A			
ATV310HU15N4•	6.5	N/A			
ATV310HU22N4•	8.8	N/A			
ATV310HU30N4•	11.1	14.2	VW3A31406		
ATV310HU40N4•	13.7	18			
ATV310HU55N4•	21.3	23			
ATV310HU75N4•	26.6	29.5	VW3A4425		
ATV310HD11N4•	36.1	38.6			
ATV310HD15N4•	46.5	46.6			
ATV310HD18N4•	55.3	54.1	VW3A311410		
ATV310HD22N4•	64.2	71.2			

# Dimensions and weights

## ATV310H037N4●, ATV310H075N4●

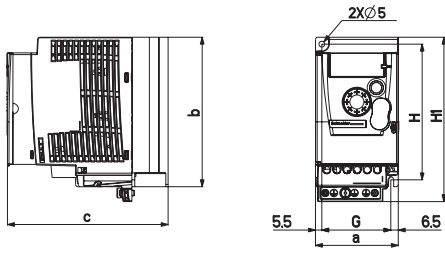

ATV310H	a mm (in.)	b mm (in.)	c mm (in.)	G mm (in.)	H mm (in.)	H1 mm (in.)	Ø mm (in.)	For screw s	Weight kg (lb)
037N4●	72 (2.83)	130 (5.12)	130 (5.12)	60 (2.36)	118 (4.65)	143 (5.63)	5 (0.20)	M4	0.8 (1.8)
075N4●	72 (2.83)	130 (5.12)	140 (5.51)	60 (2.36)	118 (4.65)	143 (5.63)	5 (0.20)	M4	0.8 (1.8)

## ATV310HU15N4●, ATV310HU22N4●

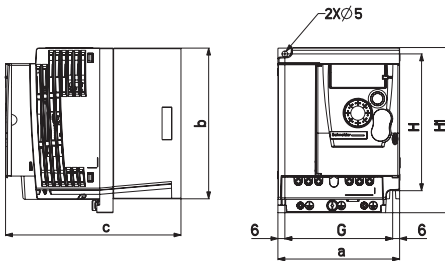

ATV310H	a mm (in.)	b mm (in.)	c mm (in.)	G mm (in.)	H mm (in.)	H1 mm (in.)	Ø mm (in.)	For screw s	Weight kg (lb)
U15N4●	105 (4.13)	130 (5.12)	151 (5.94)	93 (3.66)	118 (4.65)	143 (5.63)	5 (0.20)	M4	1.1 (2.43)
U22N4●	105 (4.13)	130 (5.12)	151 (5.94)	93 (3.66)	118 (4.65)	143 (5.63)	5 (0.20)	M4	1.1 (2.43)

## ATV310HU30N4●, ATV310HU40N4●, ATV310HU55N4●

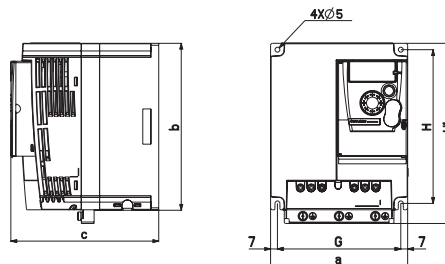

ATV310H	a mm (in.)	b mm (in.)	c mm (in.)	G mm (in.)	H mm (in.)	H1 mm (in.)	Ø mm (in.)	For screw s	Weight kg (lb)
U30N4●	140 (5.51)	171 (6.73)	151 (5.94)	126 (4.96)	157 (6.18)	184 (7.24)	5 (0.20)	M4	1.8 (3.97)
U40N4●	140 (5.51)	171 (6.73)	151 (5.94)	126 (4.96)	157 (6.18)	184 (7.24)	5 (0.20)	M4	1.8 (3.97)
U55N4●	140 (5.51)	171 (6.73)	151 (5.94)	126 (4.96)	157 (6.18)	184 (7.24)	5 (0.20)	M4	1.8 (3.97)

## ATV310HU75N4●, ATV310HD11N4●

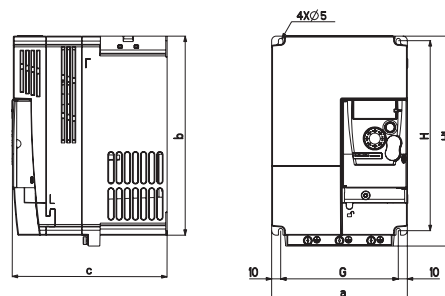

ATV310H	a mm (in.)	b mm (in.)	c mm (in.)	G mm (in.)	H mm (in.)	H1 mm (in.)	Ø mm (in.)	For screw s	Weight kg (lb)
U75N4●	150 (5.91)	220 (8.66)	171 (6.73)	130 (5.12)	210 (8.27)	232 (9.13)	5 (0.20)	M4	3.7 (8.16)
D11N4●	150 (5.91)	220 (8.66)	171 (6.73)	130 (5.12)	210 (8.27)	232 (9.13)	5 (0.20)	M4	3.7 (8.16)

# Dimensions and weights

## ATV310HD15N4●, ATV310HD18N4●

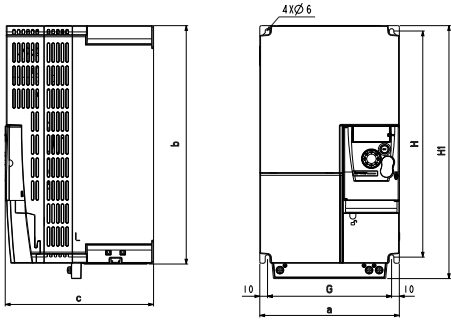

ATV310H	a mm (in.)	b mm (in.)	c mm (in.)	G mm (in.)	H mm (in.)	H1 mm (in.)	Ø mm (in.)	For screw s	Weight kg (lb)
D15N4●	180 (7.09)	311 (12.24)	191 (7.52)	160 (6.29)	295 (11.61)	330 (12.99)	6 (0.23)	M5	6.3 (13.9)
D18N4●	180 (7.09)	311 (12.24)	191 (7.52)	160 (6.29)	295 (11.61)	330 (12.99)	6 (0.23)	M5	6.3 (13.9)

**NOTE:** for ATV310HD15N4●F and ATV310HD18N4●F, the weight is 6.7 kg (14.8 lb).

## ATV310HD22N4●

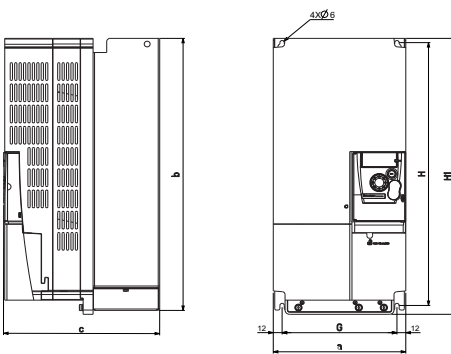

ATV310H	a mm (in.)	b mm (in.)	c mm (in.)	G mm (in.)	H mm (in.)	H1 mm (in.)	Ø mm (in.)	For screw s	Weight kg (lb)
D22N4●	180 (7.09)	384.5 (15.14)	212 (8.35)	156 (6.14)	371.5 (14.63)	390 (15.35)	6 (0.23)	M5	8.5 (18.7)

**NOTE:** for ATV310HD22N4●F, the weight is 9.7kg (21.4lb).

## Withstand to harsh environments

- Chemical class 3C3 conforming to IEC/EN 60721
- Mechanical class 3S2 conforming to IEC/EN 60721

## Temperature Conditions

Mounting types:

Type A: IP20, IP4X for top with vent cover

Type B: IP20 side by side

Type C: IP20

Ambient Air Temperature:

For	HD/ND (Heavy duty/Normal duty)	Mounting types	Temperature	
			°C	°F
Storage	All types	All types	°C	-25...70
			°F	-13...158
Operation	HD (ATV310H***N4* version)	Type B Type C	°C	-10...55 without derating
			°F	14...131 without derating
		°C	55...60 with derating	
		°F	131...140 with derating	
	HD (ATV310H***N4* version)	Type A	°C	-10...50 without derating
			°F	14...122 without derating
			°C	50...60 with derating
			°F	122...140 with derating
	HD (ATV310H***N4* F version)	Type C	°C	-10...55 without derating
			°F	14...131 without derating
			°C	55...60 with derating
			°F	131...140 with derating
	HD (ATV310H***N4* F version)	Type A Type B	°C	-10...50 without derating
			°F	14...122 without derating
			°C	50...60 with derating
			°F	122...140 with derating
	ND	Type C	°C	-10...50 without derating
			°F	14...122 without derating
			°C	50...60 with derating
			°F	122...140 with derating
ND	Type A Type B	°C	-10...40 without derating	
		°F	14...104 without derating	
		°C	40...60 with derating	
		°F	104...140 with derating	

# Environmental Conditions

---

## Relative Humidity

Without dripping water and without condensation: 5...95% according to IEC 60068-2-3

## Operating Altitude

Operating altitude		Supply voltage	Electrical supply network			Derating
			TT/TN	IT	Corner-Grounded	
m	Up to 1000	380 - 460 V three-phase	✓	✓	✓	Without derating
ft	Up to 3280					
m	1000 ... 2000	380 - 460 V three-phase	✓	✓	✓	With derating current by 1% (maxi) per additional 100 m (328 ft)
ft	3280 ... 6560					
m	2000 ... 3000	380 - 460 V three-phase	✓	✓	-	With derating current by 1% (maxi) per additional 100 m (328 ft)
ft	6560 ... 9840					

## Pollution Degree and Degree of Protection

Ambient pollution degree according to IEC/EN 61800-5-1:

Pollution Degree	Degree of Protection
2	IP20, IP4X with top vent cover. See page <a href="#">21</a> .

# Nameplate

## Nameplate example

① Product type  
② Catalog number  
③ Power rating  
④ Firmware  
⑤ Power part information  
⑥ Ecodesign regulation code  
⑦ Fuses and overload protection information  
⑧ Power part cable information  
⑨ Serial number  
⑩ Certifications

**Altivar**  
**ATV310HD15N4E**  
**15kW(HD) / 18.5kW(ND)**  
**V2.1 IE02 2026 - IE2 :2.0%**  
Input HD (ND) Output HD (ND)  
**U(V~) 380-460 Φ3 0..380-460 Φ3**  
**F(Hz) 50/60 0.5..400**  
**I(A) 46.5(46.6) 33(36)**  
**SCCR:for rating and protection refer to User Manual.**  
**HIV 25mm<sup>2</sup> 75°C**  
**2.2 to.2.4 Nm 19.5 to.21.3 lb-in**  
4086200616259001  
**EAC CE**  
www.se.com/contact  
Schneider Electric Industries SAS  
Made in China 35 Rue Joseph Monier  
FR-92500 Rueil Malmaison

## Manufacturing Date

Use the serial number ⑨ of the drive to retrieve its manufacturing date.  
The three digits after the first 7 characters of the serial number provide respectively the year and the week of manufacture.  
In the nameplate example illustrated above 40862006**16**259001 the manufacturing date is year 2026, week 16.

## Mounting

### DANGER

#### HAZARD OF ELECTRIC SHOCK, EXPLOSION, OR ARC FLASH

- The drive panel must be properly grounded before power is applied.
- Use the provided ground connecting point as shown in the figure below.

Failure to follow these instructions will result in death or serious injury.

### DANGER

#### ATV310H<sup>MMMN4M</sup> - GROUND CONTINUITY HAZARD

An anodized heatsink can create an insulation barrier to the mounting surface. Ensure that you follow the recommended grounding connections.

Failure to follow these instructions will result in death or serious injury.

### DANGER

#### ELECTRIC SHOCK CAUSED BY FOREIGN OBJECTS OR DAMAGE

Conductive foreign objects in the product or damage may cause parasitic voltage.

- Do not use damaged products.
- Keep foreign objects such as chips, screws or wire clippings from getting into the product.

Failure to follow these instructions will result in death or serious injury.

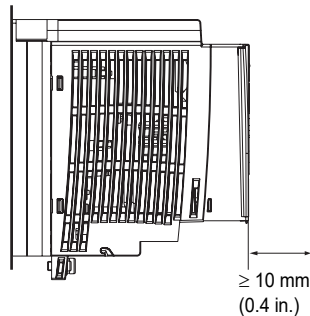
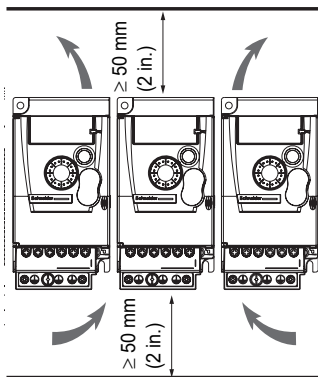

Install the drive vertically, at  $\pm 10^\circ$ .

Do not place it close to heating elements.

Leave sufficient free space to ensure that the air required for cooling purposes can circulate from the bottom to the top of the drive.

Free space in front of unit: 10 mm (0.4 in.) minimum.

When IP20 protection is adequate, we recommend that the vent cover(s) on the top of the drive be removed, as shown below.

We recommend that the drive is installed on a dissipative surface.

Drive installation should employ fastening washers and screws in combination.

## Removing the vent cover

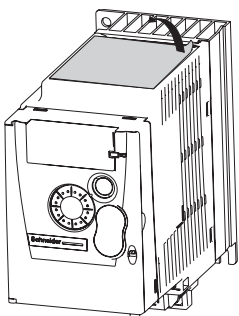

## Mounting types

### Type A mounting

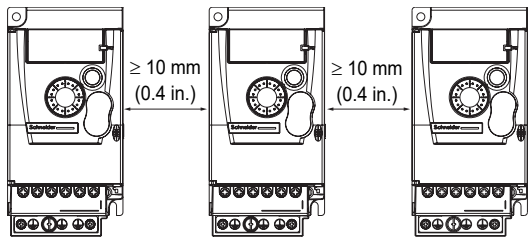

#### Type A mounting: IP20, IP4X for top with vent cover

Free space  $\geq 10$  mm (0.4 in.) on each side, with vent cover fitted.

Mounting type A is suitable for drive operation at surrounding air temperatures less than or equal to 50°C (heavy duty) or 40°C (Normal duty).

When temperature exceeds 50°C (heavy duty) or 40°C (Normal duty), the top vent cover should be removed to ensure cooling.

### Type B mounting

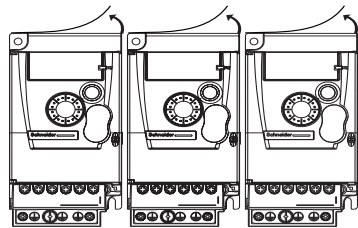

#### Type B mounting: IP20, side-by-side

Drives mounted side-by-side with vent covers removed. Mounting type B is suitable for drive operation at surrounding air temperatures less than or equal to 55°C (heavy duty) or 40°C (Normal duty).

**NOTE:** ATV310●●●N4●F operation temperatures less than or equal to 50°C (heavy duty) or 40°C (Normal duty).

### Type C mounting

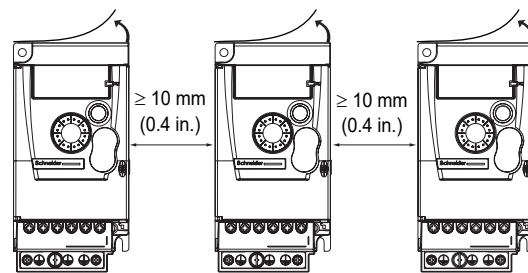

#### Type C mounting: IP20

Free space  $\geq 10$  mm (0.4 in.) on each side, without vent cover

Mounting type C is suitable for drive operation at surrounding air temperatures less than or equal to 55°C (heavy duty) or 50°C (Normal duty).

With these types of mounting, drives with a Switching frequency range of 4 kHz can be used up to an ambient temperature which was listed below:

#### For ATV310●●●N4● @ Heavy duty

1. At ambient temperatures, Type B and Type C mounting between +55°C and +60°C:

Derate current by 2.4% for every 1°C of temperature rise

Switching frequency range will adjust according to the internal temperature of the drive

2. At ambient temperatures, Type A mounting between +50°C and +60°C:

Derate current by 6% for every 1°C of temperature rise

Switching frequency range will adjust according to the internal temperature of the drive

#### For ATV310●●●N4● @ Normal duty

1. At ambient temperatures, Type C mounting between +50°C and +60°C:

Derate current by 2.1% for every 1°C of temperature rise

Switching frequency range will adjust according to the internal temperature of the drive

2. At ambient temperatures, Type B mounting between +40°C and +60°C:

Derate current by 2.2% for every 1°C of temperature rise

Switching frequency range will adjust according to the internal temperature of the drive

3. At ambient temperatures, Type A mounting between +40°C and +60°C:

Cover top safeguard covers on drives if IP4X

Derate current by 2% for every 1°C of temperature rise

Switching frequency range will adjust according to the internal temperature of the drive

## Power dissipated for enclosed drives and required air flow

Drive	Overload HD: Heavy duty ND: Normal duty	Power dissipated (W)	Minimum air flow rate required per hour (m <sup>3</sup> /h)
ATV310H037N4•	HD	22.7	6
ATV310H075N4•	HD	34.1	9
ATV310HU15N4•	HD	60.4	14
ATV310HU22N4•	HD	75.5	14
ATV310HU30N4•	HD	90.8	50
	ND	120.4	50
ATV310HU40N4•	HD	115.1	50
	ND	158.3	50
ATV310HU55N4•	HD	162.4	50
	ND	201.9	50
ATV310HU75N4•	HD	241.2	100
	ND	317.8	100
ATV310HD11N4•	HD	337.1	100
	ND	407.0	100
ATV310HD15N4•	HD	416.0	140
	ND	451.7	140
ATV310HD18N4•	HD	515.9	140
	ND	539.4	140
ATV310HD22N4•	HD	568.8	180
	ND	735.6	180
ATV310HD15N4•F	HD	424.4	140
	ND	460.2	140
ATV310HD18N4•F	HD	527.8	140
	ND	550.9	140
ATV310HD22N4•F	HD	593.5	180
	ND	765.9	180

## General instructions

### **DANGER**

#### **HAZARD OF FIRE OR ELECTRIC SHOCK**

- Wire cross sections and tightening torques must comply with the specifications provided in this document
- Do not use multi-conductor cables without cable lugs for any connection with a voltage higher than 25 Vac.

**Failure to follow these instructions will result in death or serious injury.**

Keep power cables separate from devices containing circuits with low-level signals (detectors, PLCs, measuring apparatus, video, telephone). Always cross control and power cables at 90° if possible.

## Power and circuit protection

Adhere to wire size recommendations contained in local codes and standards.

Before wiring power terminals, connect the ground terminal to the grounding screws located below the output terminals.

The drive must be grounded in accordance with the applicable safety standards.

When upstream protection by means of a residual current device is required by the installation standards, a type A circuit breaker should be used for single-phase drives and type B for 3-phase drives. Choose a suitable model incorporating:

- High frequency current filtering
- A time delay which prevents tripping caused by the load from stray capacitance on power-up. The time delay is not possible for 30mA devices.

In this case, choose devices with high interference immunity, such as RCDs with SI type leakage protection.

If the installation includes several drives, provide one "residual current device" per drive.

### **DANGER**

#### **INSUFFICIENT PROTECTION AGAINST OVERCURRENTS CAN CAUSE FIRE OR EXPLOSION**

- Use properly rated overcurrent protection devices.
- Use the fuses/circuit breakers specified.
- Do not connect the product to a supply mains whose short circuit current rating (current that flows during a short circuit) exceeds the specified permissible value.
- When rating the upstream mains fuses and the cross sections as well as the lengths of the mains cables, take into account the minimum required prospective short-circuit current (Isc). Refer to the Upstream Protection Device section.
- If the minimum required prospective short-circuit current (Isc) is not available, increase the power of the transformer or decrease the length of the cables.

**Failure to follow these instructions will result in death or serious injury.**

## Control

For control and speed reference circuits, we recommend using shielded twisted cables with a pitch of between 25 and 50 mm (1 and 2 in.). Connect the shielding to ground.

### **WARNING**

#### **UNINTENDED BEHAVIOR OF INPUTS AND OUTPUTS**

The functions of the inputs and outputs depend on the selected operating mode and the settings of the corresponding parameters.

- Verify that the wiring is appropriate for the settings.
- Only start the system if there are no persons or obstructions in the zone of operation.
- When commissioning, carefully run tests for all operating states and potential error situations.

**Failure to follow these instructions can result in death, serious injury or equipment damage.**

## Length of motor cables

Please use output filters for shielded motor cable lengths longer than 25 m (82 ft) and unshielded cables longer than 50 m (164 ft). For accessory part numbers, please refer to the catalogue.

## Equipment Grounding

Ground the drive according to local and national code requirements. A minimum wire size of 10 mm<sup>2</sup> may be required to meet standards limiting leakage current.

### **DANGER**

#### **ELECTRIC SHOCK CAUSED BY INSUFFICIENT GROUNDING**

Insufficient grounding causes the hazard of electric shocks.

- Ground the drive system before applying voltage.
- Do not use conduits as protective ground conductors; use a protective ground conductor inside the conduit.
- The cross section of the protective ground conductor must comply with the applicable standards.
- Do not consider cable shields to be protective ground conductors.

**Failure to follow these instructions will result in death or serious injury.**

### **DANGER**

#### **ATV310H<sup>MMMN</sup>4M - GROUND CONTINUITY HAZARD**

An anodized heatsink can create an insulation barrier to the mounting surface. Ensure that you follow the recommended grounding connections.

**Failure to follow these instructions will result in death or serious injury.**

### **DANGER**

#### **ELECTRIC SHOCK CAUSED BY INSUFFICIENT GROUNDING**

This product has an increased leakage current > 3.5 mA.

- Use a protective ground conductor with at least 10 mm<sup>2</sup> (AWG 6) or two protective ground conductors with the cross section of the conductors supplying the power terminals.
- Verify compliance with all local and national electrical code requirements as well as all other applicable regulations with respect to grounding of all equipment.

**Failure to follow these instructions will result in death or serious injury.**

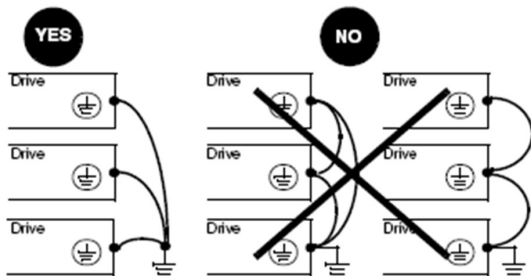

- Ensure that the resistance of the ground is one ohm or less.
- When grounding several drives, you must connect each one directly, as shown in the figure to the left.
- Do not loop the ground cables or connect them in series.

## **NOTICE**

#### **DESTRUCTION DUE TO INCORRECT MAINS VOLTAGE**

Before switching on and configuring the product, verify that it is approved for the mains voltage.

**Failure to follow these instructions can result in equipment damage.**

## **DANGER**

### **HAZARD OF FIRE OR ELECTRIC SHOCK**

For drives  $\geq 4\text{kW}$ , the length of stripped part of wires connecting motors and drives and connecting to brake resistor should not exceed 10 mm (0.4 in.).

**Failure to follow these instructions will result in death or serious injury.**

## **WARNING**

### **INSUFFICIENT PROTECTION AGAINST OVERCURRENTS**

- Properly rated overcurrent protective devices must be used.
- Do not connect the product to a supply mains whose short-circuit current rating (Isc) exceeds the permissible value (1).

**Failure to follow these instructions can result in death, serious injury or equipment damage.**

(1) the permissible value of the drive short-circuit current rating is 5 kA for product up to 4kW and 22 kA above 4 kW.

## General wiring diagram

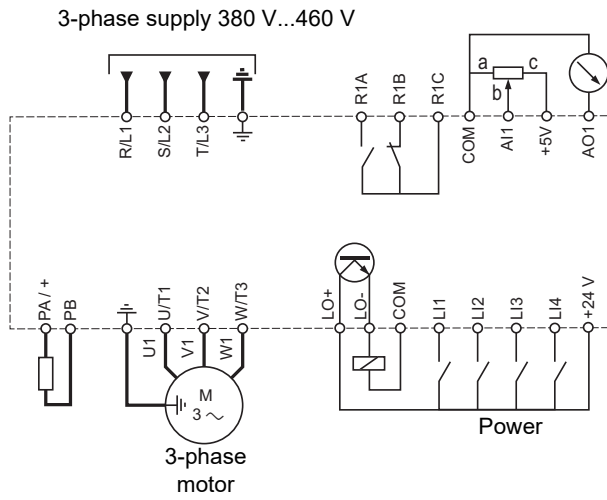

## Wiring label

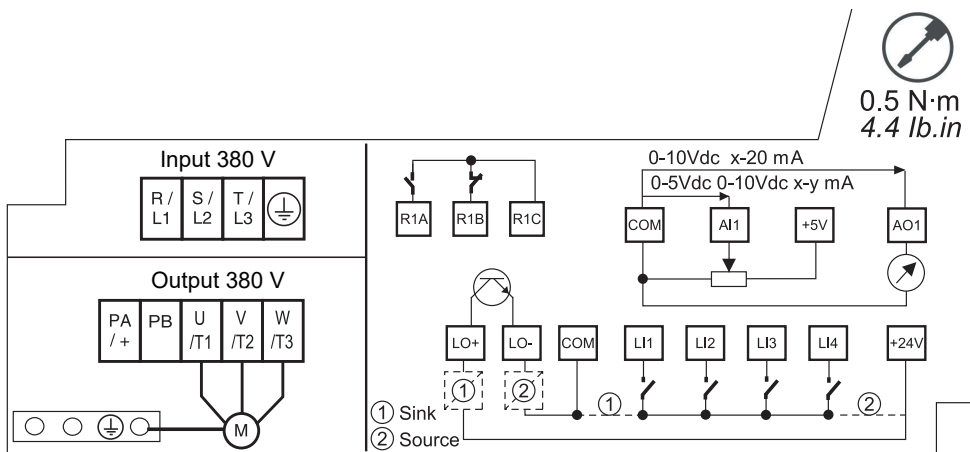

## Operation on an IT System

### Definition

**IT system:** Isolated or impedance grounded neutral. Use a permanent insulation monitoring device compatible with nonlinear loads, such as an XM200 type or equivalent.

**Corner grounded system:** System with one phase grounded.

### Operation

<b><i>NOTICE</i></b>
<b>OVERVOLTAGE OR OVERHEATING</b> If the drive is operated via an IT or corner grounded system, the integrated EMC filter must be disconnected as described in the present manual. <b>Failure to follow these instructions can result in equipment damage.</b>

## Disconnecting the Built-in EMC Filter

### Filter Disconnection

#### **⚡ ⚠ DANGER**

#### **HAZARD OF ELECTRIC SHOCK, EXPLOSION OR ARC FLASH**

Read and understand the instructions in "Before your begin" chapter before performing any procedure in this chapter.



**Failure to follow these instructions will result in death or serious injury.**

The drives have a built-in EMC filter (\*). As a result, they exhibit leakage current to ground. If the leakage current creates compatibility problems with your installation (residual current device or other), then you can reduce the leakage current by deactivating the Y capacitors as shown below. In this configuration the product does not meet the EMC requirements according to the standard IEC 61800-3.

(\*): Except ATV310HD●●N4A/ ATV310HD●●N4E drives (for 3-phase 380...460 V supply mains)

### Setting on ATV310HD●●N4AF/ ATV310HD●●N4EF drives

Apply the following instructions to set the drive to operate or not on an IT or Corner grounded system

Step	Action
1	Remove the power terminal cover
2	The switch is <b>factory set</b> to the  position shown on detail ①
3	To disconnect the built-in EMC filter, remove the screw from its location and set it to the  position as shown on detail ②
4	Refit the front cover

#### NOTE:

- Use only the screw supplied.
- Do not operate the drive with setting screw removed.

Grounding

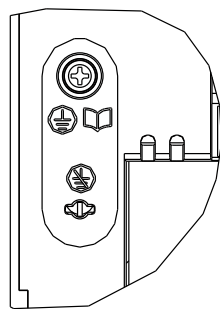

①

No

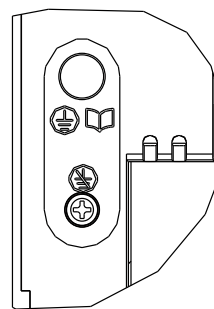

②

# Power terminals

## **DANGER**

### **HAZARD OF ELECTRIC SHOCK, EXPLOSION OR ARC FLASH**

Read and understand the instructions in "Before your begin" chapter before performing any procedure in this chapter.

**Failure to follow these instructions will result in death or serious injury.**

The incoming line power terminals and output terminals to the motor are located at the bottom of the drive. The power terminals can be accessed without opening the wiring trap if you use stripped wire cables.

## **Access to the power terminals**

Access to the terminals if you use stripped wire cables

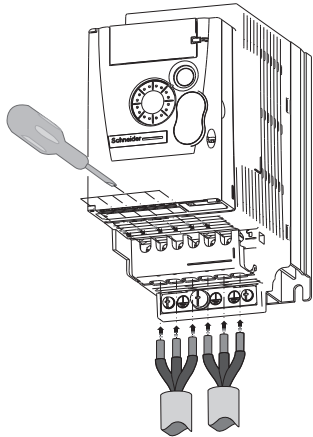

## Access to the terminals if you use ring terminals

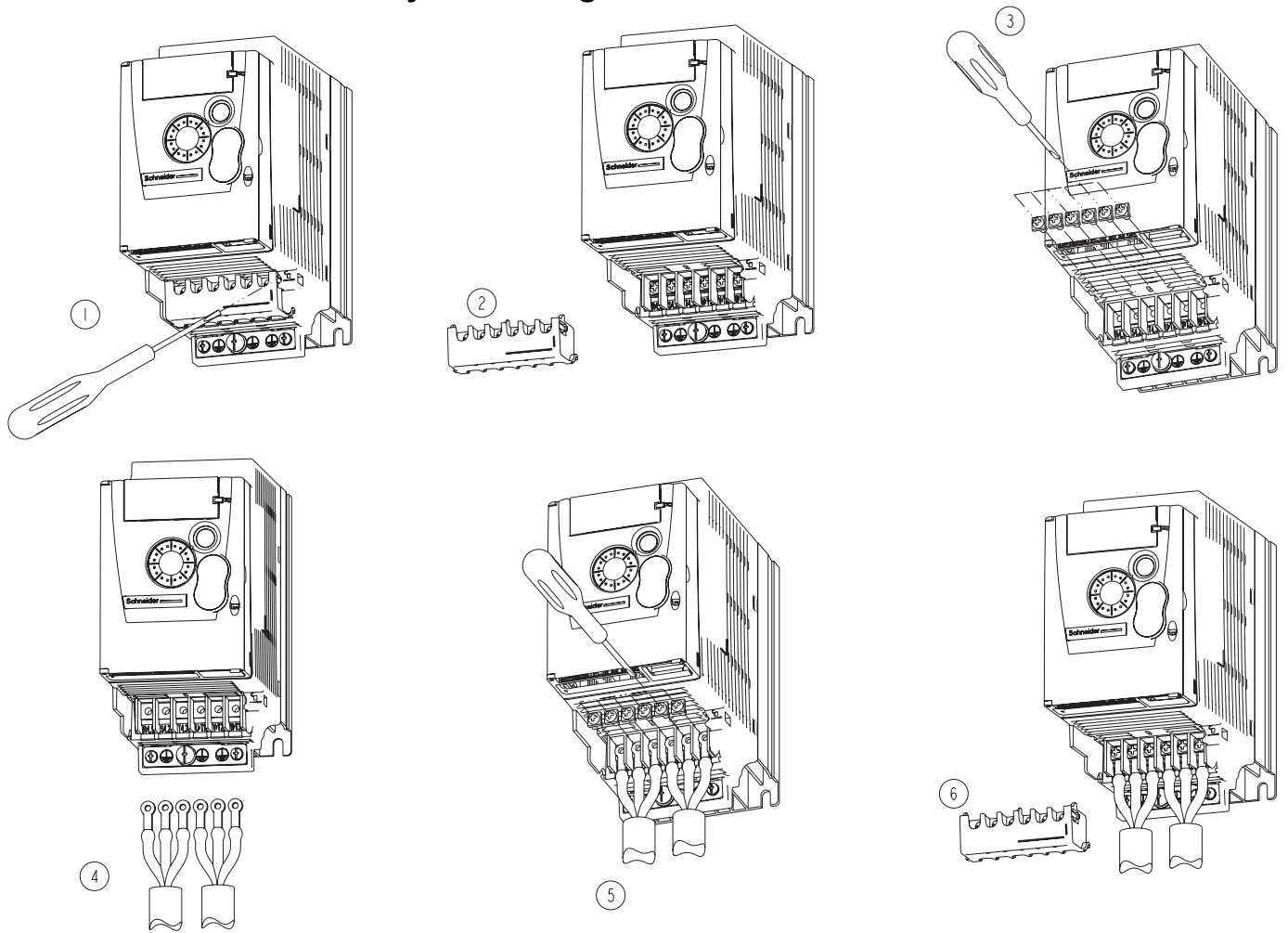

## Characteristics and functions of power terminals

Terminal	Function	For ATV310
⊥	Ground terminal	All ratings
R/L1 - S/L2 - T/L3	Power input terminal	All ratings
PA/+	Brake resistor terminal (DC Bus + output)	ATV310HU15N4●...ATV310HD22N4●
PB	Brake resistor terminal	ATV310HU15N4●...ATV310HD22N4●
U/T1 - V/T2 - W/T3	Motor wiring terminal	All ratings

# Power terminals

## Arrangement of the power terminals

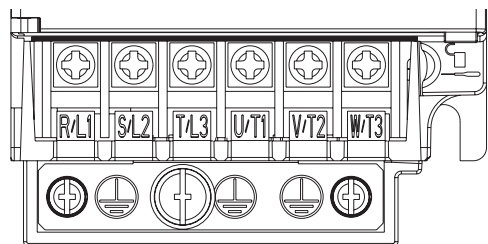

R/L1	S/L2	T/L3	U/T1	V/T2	W/T3
------	------	------	------	------	------

ATV310H	Applicable wire size (1) mm <sup>2</sup> (AWG)	Recommended wire size (2) mm <sup>2</sup> (AWG)	Tightening torque (3) N·m (lb.in)
037N4● 075N4●	1.5~2.5 (16~14)	2.5 (14)	0.8~1 (7.1 to 8.9)

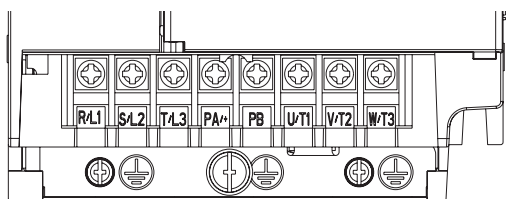

R/L1	S/L2	T/L3	PA+	PB	U/T1	V/T2	W/T3
------	------	------	-----	----	------	------	------

ATV310H	Applicable wire size (1) mm <sup>2</sup> (AWG)	Recommended wire size (2) mm <sup>2</sup> (AWG)	Tightening torque (3) N·m (lb.in)
U15N4● U22N4●	1.5~2.5 (16~14)	2.5 (14)	0.8~1 (7.1 to 8.9)

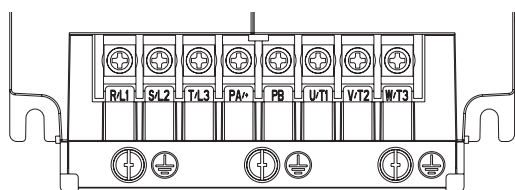

R/L1	S/L2	T/L3	PA+	PB	U/T1	V/T2	W/T3
------	------	------	-----	----	------	------	------

ATV310H	Applicable wire size (1) mm <sup>2</sup> (AWG)	Recommended wire size (2) mm <sup>2</sup> (AWG)	Tightening torque (3) N·m (lb.in)
U30N4● U40N4● U55N4●	1.5~4 (16~12) 2.5~4 (14~12) 4 (12)	2.5 (14) 4 (12) 4 (12)	1.2~1.4 (10.6 to 12.4)

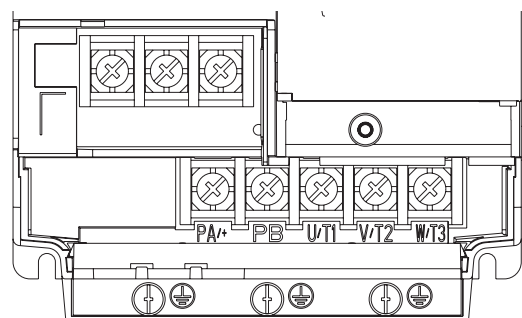

R/L1	S/L2	T/L3	PA+	PB	U/T1	V/T2	W/T3
------	------	------	-----	----	------	------	------

ATV310H	Applicable wire size (1) mm <sup>2</sup> (AWG)	Recommended wire size (2) mm <sup>2</sup> (AWG)	Tightening torque (3) N·m (lb.in)
U75N4● D11N4●	6~10 (10~7) 10 (7)	10 (7) 10 (7)	2.2~2.4 (19.5 to 21.2)

# Power terminals

## Arrangement of the power terminals

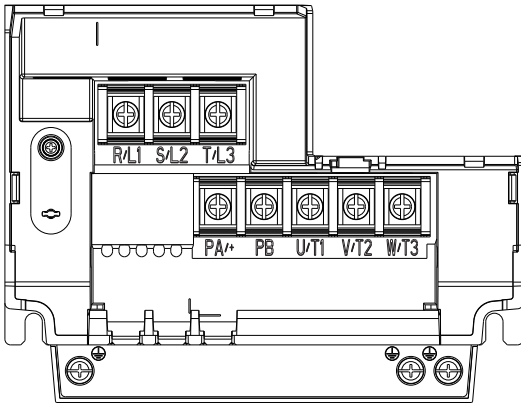

R/L1	S/L2	T/L3	PA+	PB	U/T1	V/T2	W/T3
------	------	------	-----	----	------	------	------

ATV310H	Overload HD: Heavy duty ND: Normal duty	Applicable wire size (1) mm <sup>2</sup> (AWG)		Recommended wire size (2) mm <sup>2</sup> (AWG)		Tightening torque (3) N·m (lb.in)
		Supply terminals	Output terminals	Supply terminals	Output terminals	
D15N4●	HD	<b>16~25(4~3)</b>	<b>10~25(6~3)</b>	25(3)	16(4)	2.2~2.4 (19.5 to 21.2)
	ND	<b>16~25(4~3)</b>	<b>10~25(6~3)</b>	25(3)	16(4)	
D18N4●	HD	25(3)	<b>10~25(6~3)</b>	25(3)	16(4)	2.2~2.4 (19.5 to 21.2)
	ND	<b>16~25(4~3)</b>	<b>16~25(4~3)</b>	25(3)	16(4)	

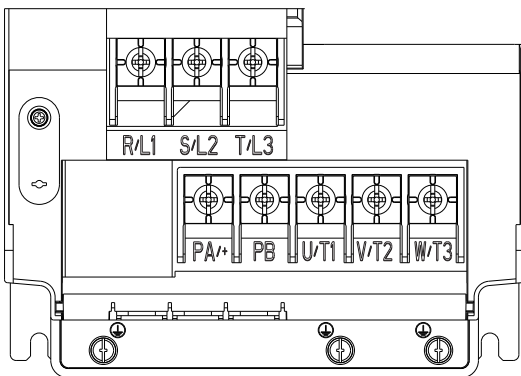

R/L1	S/L2	T/L3	PA+	PB	U/T1	V/T2	W/T3
------	------	------	-----	----	------	------	------

ATV310H	Overload HD: Heavy duty ND: Normal duty	Applicable wire size (1) mm <sup>2</sup> (AWG)		Recommended wire size (2) mm <sup>2</sup> (AWG)		Tightening torque (3) N·m (lb.in)
		Supply terminals	Output terminals	Supply terminals	Output terminals	
D22N4●	HD	35(2)	<b>16~35(4~2)</b>	35(2)	25(3)	4.5~5.0 (39~44.3)
	ND	<b>25~35(3~2)</b>	<b>25~35(3~2)</b>	35(2)	25(3)	

- (1) The value in bold corresponds to the minimum wire gauge to permit secureness.  
 (2) 70°C copper cable (minimum wire size for rated use).  
 (3) Recommended to maximum value.

## Screwdriver(s)

For ≤18.5 kW terminal wiring, use Phillips-head screwdriver PH2 (Ø6).  
 For 22 kW terminal wiring, use Phillips-head screwdriver PH2 (Ø6) or PH3 (Ø8).

# Power terminals

## The specification of main circuit terminal

- For  $\geq 15$  kW, if the wire terminal is  $> 10\text{mm}^2$  (AWG 6), the ring lug is required for main circuit terminal connection, please refer to **Figure 1** for the specifications of the ring lug.
- Wire should be crimped into UL compliant ring lug before putting on the insulated heat shrink tube, which is UL and CSA compliant, 600 Vac voltage withstand, YUPU2, please refer to **Figure 2** for the specifications of the heat shrink tube.

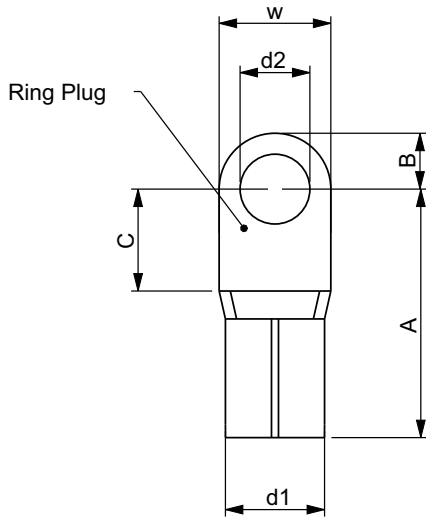

Figure 1

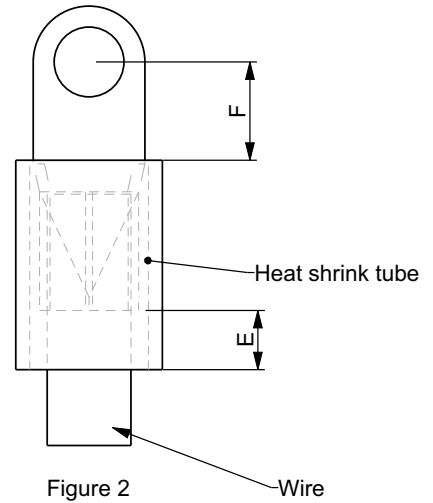
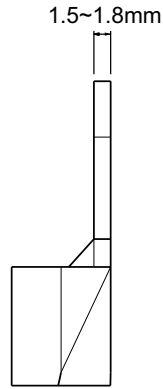

Figure 2

Ring lug size table:

Rated Output Power (kW)	Input Cable Cross -section (mm <sup>2</sup> )	Motor Cable Cross -section (mm <sup>2</sup> )	A (MAX)	B (MAX)	C (MIN)	d1	d2 (MIN)	E (MIN)	F (Range)	W (MAX)
15 18.5	16~25 (AWG6~4)	10~25 (AWG6~3)	33	10	12	Depend on cable	5.2	13	10~14	13
22	25~35 (AWG3~2)	16~35 (AWG4~2)	33	8	12	Depend on cable	6.2	13	10~14	16

# Control terminals

Keep the control circuits away from the power cables. For control and speed reference circuits, we recommend using shielded twisted cables with a pitch of between 25 and 50 mm (1 and 2 in.). Connect the shield to ground as outlined on page [38](#).

## Access to the control terminals

To access the control terminals, open the cover.

**NOTE:** For information regarding HMI button functions, see "HMI description" on page [42](#).

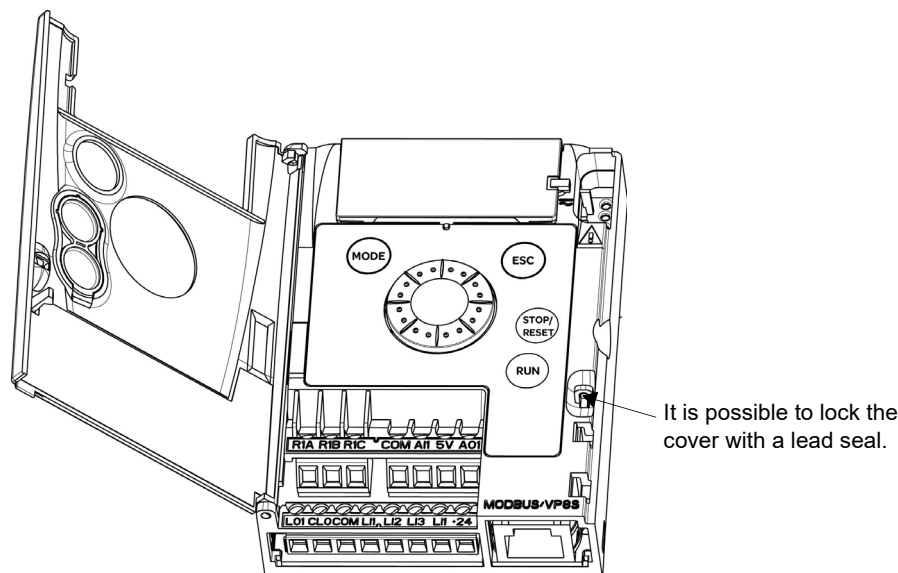

## Arrangement of control terminals

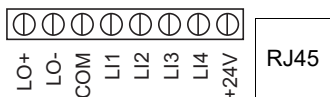

- R1A Normally open (NO) contact of the relay
- R1B Normally closed (NC) contact of the relay
- R1C Common pin of the relay
- COM COMmon of analog and logic I/Os
- AI1 Analog Input
- 5V +5VDC supply provided by the drive
- AO1 Analog Output
- LO+ Logic Output (collector)
- LO- Common of the logic Output (emitter)
- COM COMmon of analog and logic I/Os
- L1 Logic Input
- L2 Logic Input
- L3 Logic Input
- L4 Logic Input
- +24V +24 VDC supply provided by the drive
- RJ45 Modbus network or remote display panel interface.

ATV310 Control terminals	Applicable wire size (1) mm <sup>2</sup> (AWG)	Tightening torque (2) N·m (lb.in)
R1A, R1B, R1C	<b>0.75</b> to 1.5 ( <b>18</b> to 16)	0.5 to 0.6 (4.4 to 5.3)
Other terminals	<b>0.14</b> to 1.5 ( <b>26</b> to 16)	

(1) The value in bold corresponds to the minimum wire gauge to permit secureness.

(2) Recommended to maximum value.

## Recommended screwdriver(s)

Control terminal wiring requires a Phillips-head screwdriver PH0 (Ø3).

## Characteristics and functions of the control terminals

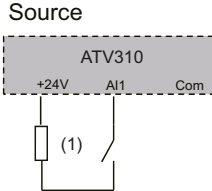
Terminal	Function	Electrical Characteristics
R1A	NO contact of the relay	Minimum switching capacity: • 5 mA for 24 V $\text{---}$
R1B	NC contact of the relay	Maximum switching capacity: • on inductive load ( $\cos \varphi = 0.4$ and $L/R = 7$ ms): 2 A for 250 V $\sim$ and 30 V $\text{---}$
R1C	Common pin of the relay	• on resistive load ( $\cos \varphi = 1$ and $L/R = 0$ ): 3 A for 250 V $\sim$ , 4 A for 30 V $\text{---}$ • response time: 30ms maximum.
COM	Common of analog and logic I/Os	
AI1	Voltage or current analog input	<ul style="list-style-type: none"> <li>• resolution: 10 bits</li> <li>• precision: <math>\pm 1\%</math> at 25°C (77°F)</li> <li>• linearity: <math>\pm 0.3\%</math> (of full scale)</li> <li>• sampling time: 20 ms <math>\pm</math> 1 ms</li> <li>• analog voltage input 0 to +5 V or 0 to + 10 V (maximum voltage 30 V) impedance: 30 k<math>\Omega</math></li> <li>• Analog current input x to y mA, impedance: 250 <math>\Omega</math></li> </ul>
LIU	Logic input plus	<ul style="list-style-type: none"> <li>• When the inverter input is positive logic connection (source mode), by setting the AI1 type to LIU, and adding the pull-up resistor, AI1 can be used as a logic input.</li> <li>• When the inverter input is negative logic connection (sink mode), AI1 do not support to use as LIU logic input.</li> <li>• When AI1 is used as a logic input, the input impedance is 30k<math>\Omega</math>;</li> </ul> Internal power supply or external power supply, the maximum input voltage of AI1 port is 20 V - if $\leq 3$ V, state 0 - if $\geq 7$ V, state 1 <div style="text-align: center; margin: 10px 0;">  </div> <p>(1) The series resistance is 15k<math>\Omega</math>.</p>
5V	Power supply for reference potentiometer	<ul style="list-style-type: none"> <li>• precision: <math>\pm 5\%</math></li> <li>• maximum current: 10 mA</li> </ul>
AO1	Voltage or current analog output	<ul style="list-style-type: none"> <li>• resolution: 8 bits</li> <li>• precision: <math>\pm 1\%</math> at 25°C (77°F)</li> <li>• linearity: <math>\pm 0.3\%</math> (of full scale)</li> <li>• sampling time: 4 ms (max. 7 ms)</li> <li>• analog voltage output: 0 to +10 V (maximum voltage +1%)</li> <li>• minimum output impedance: 470 <math>\Omega</math></li> <li>• analog current output: x to 20 mA</li> <li>• maximum output impedance: 800 <math>\Omega</math></li> </ul>
LO+	Logic output	<ul style="list-style-type: none"> <li>• voltage: 24 V (maximum 30 V)</li> <li>• impedance: 1k<math>\Omega</math></li> <li>• max current output: 100mA (1)</li> <li>• linearity: <math>\pm 1\%</math></li> <li>• sampling time: 20 ms <math>\pm</math> 1 ms.</li> </ul>
LO-	Common of the logic output (emitter)	
LI1 LI2 LI3 LI4	Logic inputs	Programmable logic inputs <ul style="list-style-type: none"> <li>• +24 VDC power supply (maximum 30 V)</li> <li>• impedance: 3.5 k<math>\Omega</math></li> <li>• state: 0 if <math>&lt; 5</math> V, state 1 if <math>&gt; 11</math> V in positive logic</li> <li>• state: 1 if <math>&lt; 10</math> V, state 0 if <math>&gt; 16</math> V or switched off (not connected) in negative logic</li> <li>• sampling time: <math>&lt; 20</math> ms <math>\pm</math> 1 ms.</li> </ul>
+24V	+24 VDC supply provided by the drive	+24 VDC -15% +20% protected against short-circuits and overloads. Maximum customer current available: 100 mA

(1) LO logic output maximum current could be 100 mA when external power supply or internal +24 V supply alone to LO. If the internal +24 V supply logic inputs also, the maximum current will be 80 mA

## Modbus Connection (RJ45)

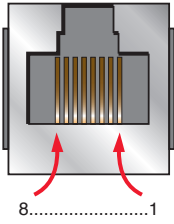

Pin	Signal
1	Reserved
2	
3	
4	D1 (1)
5	D0 (1)
6	Reserved
7	VP <b>NOTE:</b> Supply for RS232 / RS485 converter or a remote terminal.
8	Common (1)
<b>NOTICE</b>	
<b>RISK OF SERIAL PORT DAMAGE</b>	
Do not connect shield layer of the cable to Common (pin8).	
<b>Failure to follow these instructions can result in equipment damage.</b>	
(1) Modbus signals.	

## Control connection diagrams

Logic inputs type 203 parameter (page 62) is used to adapt the operation of the logic inputs to the technology of the programmable controller outputs.

- Set the parameter to 00 for Source operation.
- Set the parameter to 01 for internal Sink operation.
- Set the parameters to 02 for external Sink operation.

**NOTE:** The modification will be taken into account only at the next control power-on.

Source - using external supply

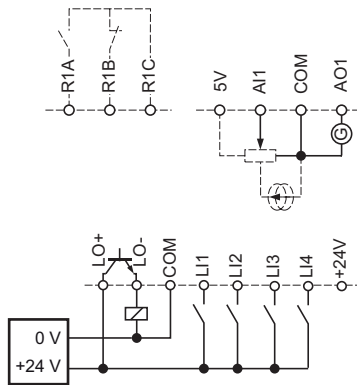

Sink - using external supply

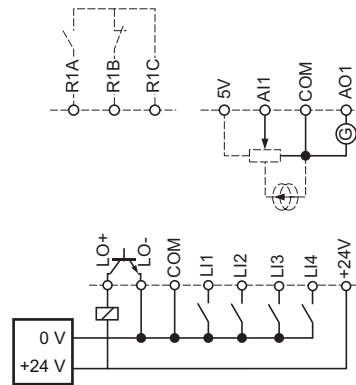

Source - using internal supply

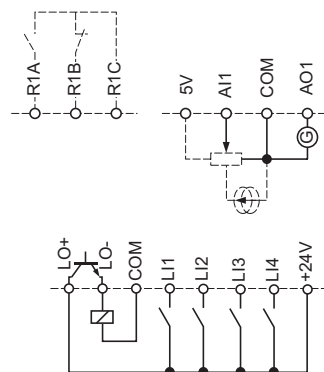

Sink - using internal supply

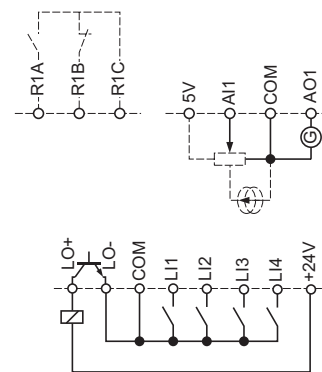

### **⚠ WARNING**

#### **UNANTICIPATED EQUIPMENT OPERATION**

- If the function Logic input type 203 is set to "01" or "02", do not connect the "0 V" terminal to ground or to protective ground.
- Verify that accidental grounding of digital inputs configured for sink logic, caused, for example, by damage to the signal cables, cannot occur.
- Follow all applicable standards and directives such as NFPA 79 and EN 60204 for proper control circuit grounding practices.
- If you connect a PLC with sink output to the drive:
  - Make sure to set the parameter 203 to "02" before you connect the PLC to the drive.
  - Disconnect the hardware wiring between PLC and drive when you try to restore the factory setting 102 to "64" of the drive.

**Failure to follow these instructions can result in death, serious injury or equipment damage.**

# Electromagnetic Compatibility

## Electromagnetic Compatibility (EMC), Wiring

### EMC requirements for the control cabinet

EMC measures	Objective
Use mounting plates with good electrical conductivity, connect large surface areas of metal parts, remove paint from contact areas.	Good conductivity due to large surface contact.
Ground the control cabinet, the control cabinet door and the mounting plate with ground straps or ground wires. The conductor cross section must be at least 10 mm <sup>2</sup> (AWG 8).	Reduces emissions.
Fit switching devices such as power contactors, relays or solenoid valves with interference suppression units or arc suppressors (for example, diodes, varistors, RC circuits).	Reduces mutual interference.
Install power components and control components separately.	

### Shielded cables

EMC measures	Objective
Connect large surface areas of cable shields, use cable clamps and ground straps.	Reduces emissions.
Use cable clamps to connect a large surface area of the shields of all shielded cables to the mounting plate at the control cabinet entry.	
Ground shields of digital signal wires at both ends by connecting them to a large surface area or via conductive connector housings	Reduces interference affecting the signal wires, reduces emissions
Ground the shields of analog signal wires directly at the device (signal input); insulate the shield at the other cable end or ground it via a capacitor (for example, 10 nF, 100 V or higher).	Reduces ground loops due to low-frequency interference.
Use only shielded motor cables with copper braid and a coverage of at least 85%, ground a large surface area of the shield at both ends.	Diverts interference currents in a controlled way, reduces emissions.

### Cable Installation

EMC measures	Objective
Do not route fieldbus cables and signal wires in a single cable duct together with lines with DC and AC voltages of more than 60 V (fieldbus cables, signal lines and analog lines may be in the same cable duct). Recommendation: Use separate cable ducts at least 20 cm apart.	Reduces mutual interference.
Keep cables as short as possible. Do not install unnecessary cable loops, use short cables from the central grounding point in the control cabinet to the external ground connection.	Reduces capacitive and inductive interference.
Use equipotential bonding conductors in the following cases: wide-area installations, different voltage supplies and installation across several buildings.	Reduces current in the cable shield, reduces emissions.
Use fine stranded equipotential bonding conductors.	Diverts high-frequency interference currents
If motor and machine are not conductively connected, for example by an insulated flange or a connection without surface contact, you must ground the motor with a ground strap or a ground wire. The conductor cross section must be at least 10 mm <sup>2</sup> (AWG 6).	Reduces emissions, increases immunity.
Use twisted pair for the DC supply. For digital and analog inputs use shielded twisted cables with a pitch of between 25...50 mm (1...2 in).	Reduces interference affecting the signal cables, reduces emissions.

### Power Supply

EMC measures	Objective
Operate product on mains with grounded neutral point.	Enables effectiveness of mains filter.
Surge arrester if there is a risk of overvoltage.	Reduces the risk of damage caused by overvoltage.

# Check list Before Switching On

---

## Mechanical Installation

Verify the mechanical installation of the entire drive system:

Step	Action	✓
1	Does the installation meet the specified distance requirements?	
2	Did you tighten all fastening screws with the specified tightening torque?	

## Electrical installation

Verify the electrical connections and the cabling:

Step	Action	✓
1	Did you connect all protective ground conductors?	
2	Does circuit breaker has the correct rating refer to page <a href="#">14</a> .	
3	Did you connect or insulate all wires at the cable ends?	
4	Did you properly connect and install all cables and connectors?	
5	Do all plug-in terminals colors and markings correspond to the colors and marking of the control block?	
6	Did you properly connect the signal wires?	

## Covers And Seals

Verify that all covers and seals of the control cabinet are properly installed to meet the required degree of protection.

## Drive factory settings

The ATV310 is factory-set for the most common operating conditions (motor rating according to drive rating):

- Display: drive ready ( - - **DD** ) with motor stopped or motor frequency reference while running
- Automatic adaptation of the deceleration ramp in the event of overvoltage on braking
- No automatic restarting after a detected fault is cleared
- Logic inputs:
  - LI1: forward (2-wire transitional control)
  - LI2, LI3, LI4: no assignment
- Logic output: LO1: no assignment
- Analog input: AI1 (0 to + 5 V) speed reference
- Relay R1: fault as default setting. R1A opens and R1B closes when a fault is detected or no line voltage is present.
- Analog output AO1: no assignment

Code	Description	Value	Page
<b>3 0 1</b>	Standard motor frequency	50 Hz	<a href="#">68</a>
<b>3 0 4</b>	Rated motor voltage	380 V	<a href="#">68</a>
<b>5 0 1.0</b>	Acceleration	3 s	<a href="#">83</a>
<b>5 0 1.1</b>	Deceleration	3 s	<a href="#">83</a>
<b>5 12.0</b>	Low speed	0 Hz	<a href="#">109</a>
<b>5 12.2</b>	High speed	50 Hz	<a href="#">110</a>
<b>3 0 9</b>	Motor control type	Standard U/F law	<a href="#">69</a>
<b>3 1 0</b>	IR compensation	100%	<a href="#">70</a>
<b>6 0 4.0</b>	Motor thermal current	equal to nominal motor current (value determined by drive rating)	<a href="#">114</a>
<b>5 0 4.1</b>	Automatic DC injection current	0.7 x rated drive current, for 0.5 seconds.	<a href="#">88</a>
<b>3 1 5</b>	Switching frequency	4 kHz	<a href="#">71</a>

If the above values are compatible with the application, the drive can be used without changing the settings.

## Drive factory wiring diagram

ATV310●●●●N4●

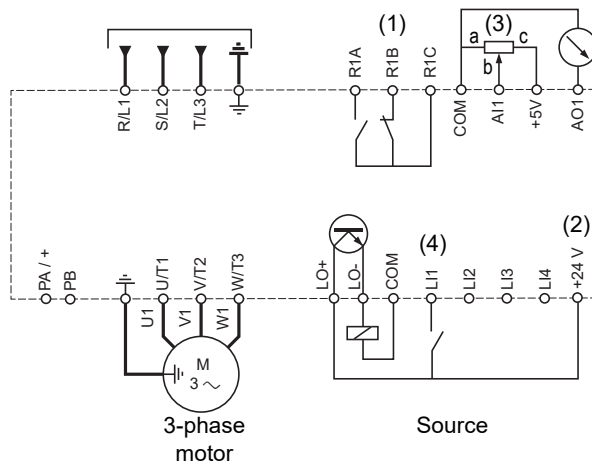

(1) R1 relay contacts, for remote indication of the drive status.

(2) Internal + 24 V  $\equiv$ . If an external source is used (+ 30 V  $\equiv$  maximum), connect the 0 V of the source to the COM terminal, and do not use the + 24 V  $\equiv$  terminal on the drive.

(3) Reference potentiometer SZ1RV1202 (2.2 k $\Omega$ ) or similar (10 k $\Omega$  maximum).

(4) Forward.

## Status relay, unlocking

The R1 status relay is energized when the drive power is applied with no fault detected. It de-energizes in the event of a detected fault or when the drive power is removed.

The drive is reset after a detected fault:

- by switching off the drive until the display disappears completely, then switching on again.
- automatically when "automatic restart" function is enabled, [fault detection menu 600 -](#), [Automatic restart 602.0](#) parameter (page [111](#)) set to [0 1](#).
- via a logic input when this input is assigned to the "drive reset" function, [fault detection menu 600 -](#) menu, [Detected fault reset assignment 601](#) (page [111](#)) set to L●H.
- by using the "run" key on the drive to reset section fault. See [Reset all previous detected faults via Run key of HMI 614](#) parameter (page [117](#)).

## Drive thermal detection

Thermal detection is provided by a built-in PTC probe in the power module.

## Drive ventilation

Ratings up to 0.75 kW (1 HP) do not include a fan. Other ratings do contain a built-in cooling fan. There are two cooling fan run modes: in the first, the fan runs when drive is running; in the second, the fan runs when the drive thermal state requires ventilation. The fan runs only runs when the drive thermal state requires ventilation.

## Motor thermal detection

Function:

Thermal detection by calculating the  $I^2t$ .

**NOTE:** The motor thermal state memo returns to zero when the drive power is cycled if [Motor thermal state memo 604.3](#) parameter (page [114](#)) is not set to [0 1](#).

### **NOTICE**

#### **MOTOR OVERHEATING**

The motor thermal state is not saved when drive is switched off.

When the drive is switched on, it is not aware of the thermal state of the connected motor or motors.

To enable correct temperature monitoring of the motors, install an external temperature sensor for each motor.

**Failure to follow these instructions can result in equipment damage.**

### **NOTICE**

#### **MOTOR OVERHEATING**

Install external thermal monitoring equipment under the following conditions:

- If a motor with a nominal current of less than 20% of the nominal current of the drive is connected.
- If you use the function Motor Switching.
- If several motors are connected to the same drive

**Failure to follow these instructions can result in equipment damage.**

## HMI description

### Functions of the display and keys

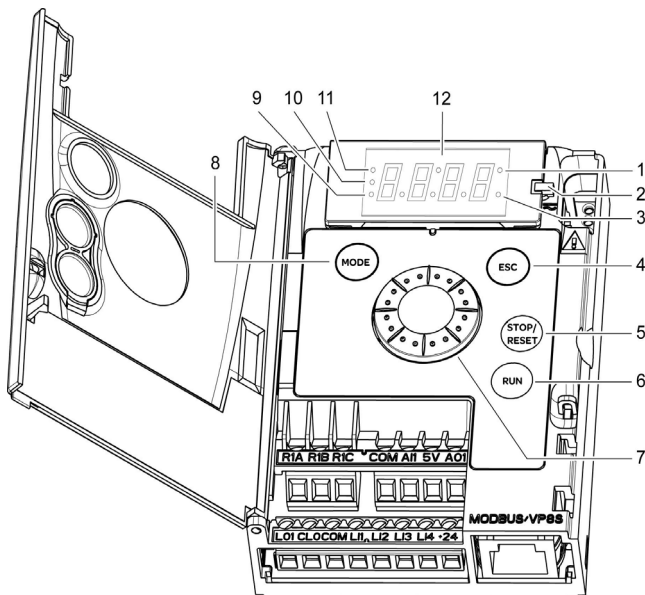

1. Value LED (a) (b)
2. Charge LED
3. Unit LED (c)
4. ESC button: Exits a menu or parameter, or aborts the displayed value to return to the previous value in the memory. In LOCAL configuration, a 2 s press on ESC button switches between the control/programming modes.  
**NOTE:** In LOCAL configuration, the three Leds 9, 10, 11 are blinking simultaneously in programming mode and are working as a Led chaser in control mode.
5. **STOP/RESET button: stops the motor (could be hidden by door if function disabled). Important: See instructions for "RUN/STOP" cover removal.**
6. RUN button: Starts running in LOCAL configuration and in REMOTE configuration if the function is configured (could be hidden by door if function disabled).
7. Jog Dial
  - Acts as a potentiometer in local mode in LOCAL configuration and in REMOTE configuration if the function is configured
  - For navigation when turned clockwise or counterclockwise
  - And selection / validation when pushed
 This action is represented by the symbol on the right.
8. MODE button
  - Switches between the control/programming modes. A 3 s press on MODE button switches between the REMOTE/LOCAL configurations.
9. CONFIGURATION mode LED (b)
10. MONITORING mode LED
11. REFERENCE mode LED
12. Four "7-segment" displays

**NOTE:** In LOCAL configuration, the three Leds 9, 10, 11 are blinking simultaneously in programming mode and are working as a Led chaser in control mode.

- (a) If illuminated, indicates that a **value** is displayed, for example, **0.5** is displayed for "0.5".  
 (b) When changing a value the Configuration mode LED and the value LED are on steady.  
 (c) If illuminated, indicates that a **unit** is displayed, for example, AMP is displayed for "Amps".

## ⚠ WARNING

### LOSS OF CONTROL

The function **Stop key priority 405** parameter disables the Stop keys of the drive and of the Remote Display Terminal if the setting of the parameter is **00**.

Only set this parameter to **00** if you have implemented appropriate alternative stop functions.

**Failure to follow these instructions can result in death, serious injury or equipment damage.**

# Programming

---

## Remote control

Remote operation and programming by HMI is possible using the optional display terminal part VW3A1006. The dimensions of the display terminal part are 70 mm (2.76 in) x 50 mm (2.76 in).



**NOTE:** Set the remote display terminal with:

- Modbus rate = 19.2 Kbps, (see [702](#), page [118](#) )
- Modbus format = 8E1, 8 bit, even parity, 1 stop bit (see [703](#), page [118](#)).

## First power-up

At first power-up you are prompted to set **Standard motor frequency 301** (page 68). Next time power is applied **--00** appears. Operating mode selection is then possible using the MODE or JOG key as detailed below.

## Menus structure

Access to menus and parameters is possible through the Reference (**rEF**) mode (page 49), Monitoring (**B00-**) mode (page 49) and Configuration (**ConF**) mode (page 55). Switching between these modes is possible at any time using the MODE key or Jog Dial on the keyboard. The first MODE key depression moves from current position to the top of the branch. A second depression switches to next mode.

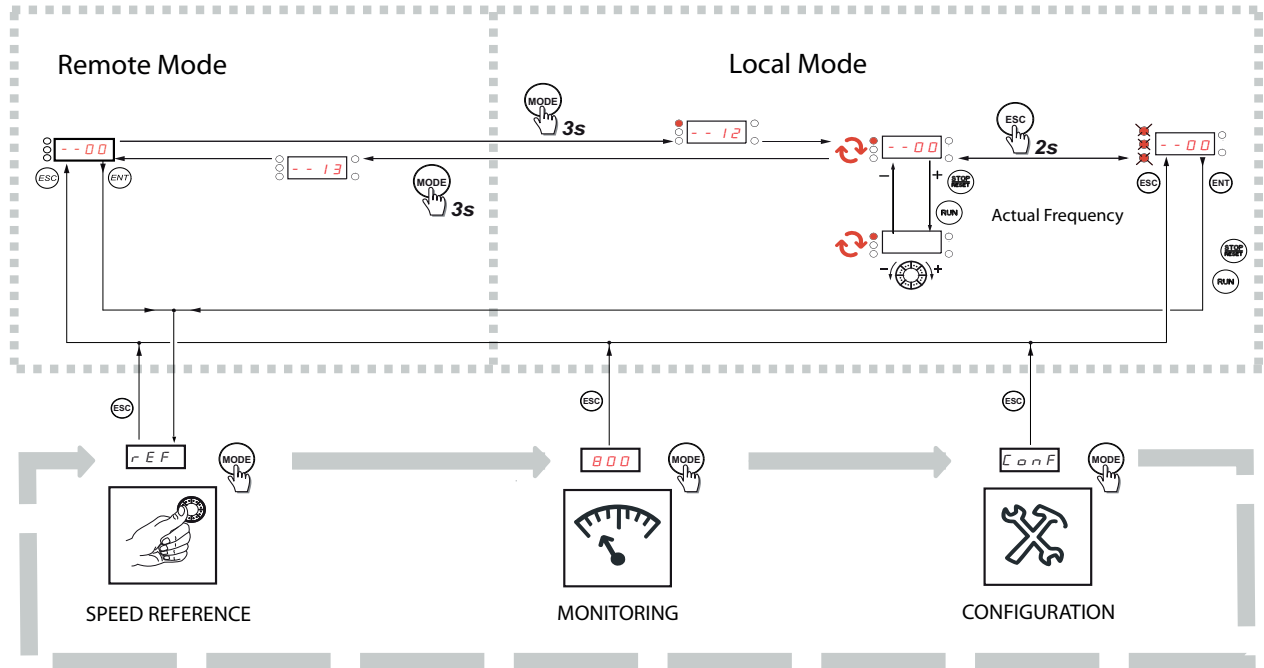

# Structure of parameter tables

The mode, sectional, menu, sub-menu and parameter table structure is laid out below.

**NOTE:** Parameters containing the sign (⌘) in the code column can be modified with the drive running or stopped.

Example:

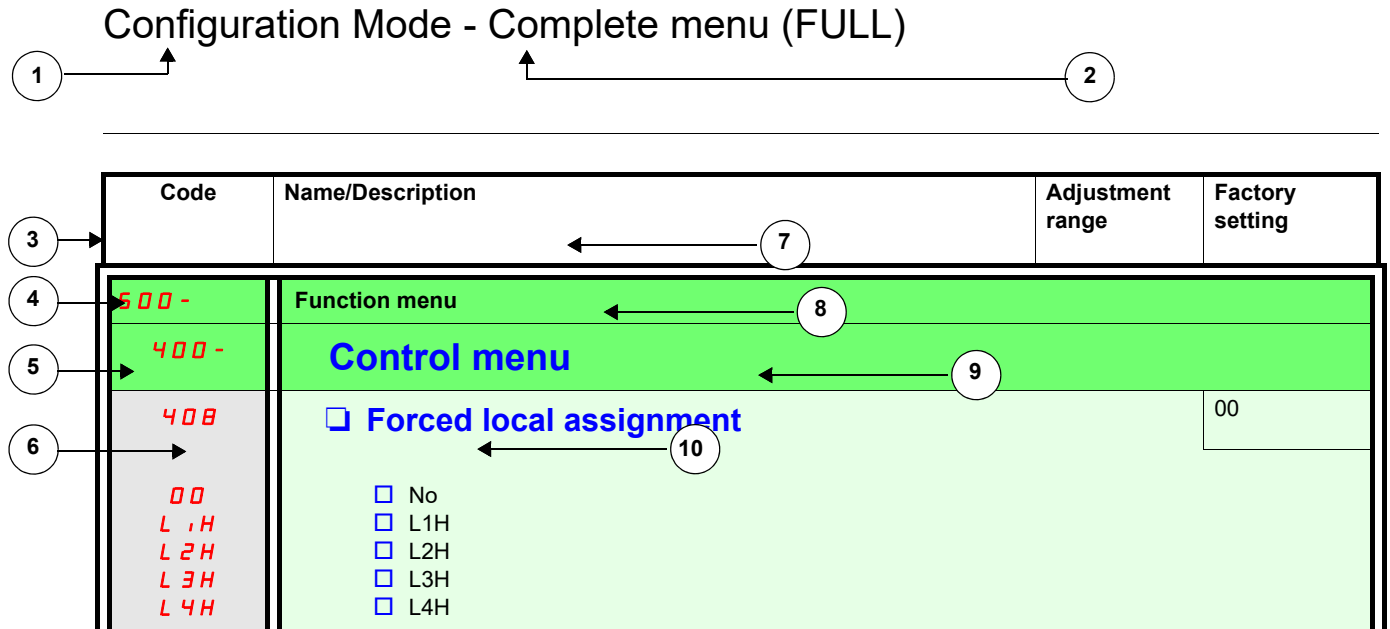

- |   |   |
|---|---|
| <b>1.</b> Name of mode  | <b>6.</b> Value code                                      |
| <b>2.</b> Name of section, if any                                   | <b>7.</b> Name of menu                                    |
| <b>3.</b> Menu code on 4-digit 7-segment display, followed by a "-" | <b>8.</b> Name of sub-menu                                |
| <b>4.</b> Sub-menu code on 4-digit 7-segment display, if any        | <b>9.</b> Parameter description                           |
| <b>5.</b> Parameter code  | <b>10.</b> Possible value(s) / state of parameter, if any |

# Function compatibility table

	Preset speed (page 92)	PI regulator (page 93)	Jog operation (page 89)	Auto DC injection (page 88)	Catch on the fly (page 112)	Fast stop (page 85)	Freewheel (page 85)	DC injection (page 86)
Preset speed (page 92)			*					
PI regulator (page 93)			M					
Jog operation (page 89)	>	M		>				
Auto DC injection (page 88)			*				*	*
Catch on the fly (page 112)							>	
Fast stop (page 85)							*	M (1)
Freewheel (page 85)				>	*	>		>
DC injection (page 86)				>		M (1)	*	

Incompatible functions   
  Compatible functions   
  Not applicable  
 The function indicated by the arrow has priority over the other.

←  ↑ Priority function (function which can be active at the same time)

(1) Priority is given to the first of these two stop modes to be activated.

Stop functions have priority over run commands.  
 Speed references via logic command have priority over analog references.

# Reference Mode rEF

Use the reference mode to monitor and if local control is enabled (Reference channel 1 401 page 81 = 183), adjust the actual reference value by rotating the jog dial.

When local control is enabled, the jog dial of the HMI acts as a potentiometer to change the reference value up and down within the limits preset by other parameters (512.0 and 512.2). There is no need to press the ENT key to confirm the change of the reference.

If local command mode is disabled, using Command channel 1 407 page 82, only reference values and units are displayed. The value will be "read only" and cannot be modified by the jog dial (the reference is no longer given by the jog dial but from an AI or other source). The actual reference displayed determined by the choice made in Reference channel 1 401 page 81.

## Organization tree

(1) Determined by active reference channel.

Possible values:

- 402
- 403
- 801
- 59.11
- 806

(2) 2 s or ESC

Displayed parameter value and unit of the diagram are given as examples.

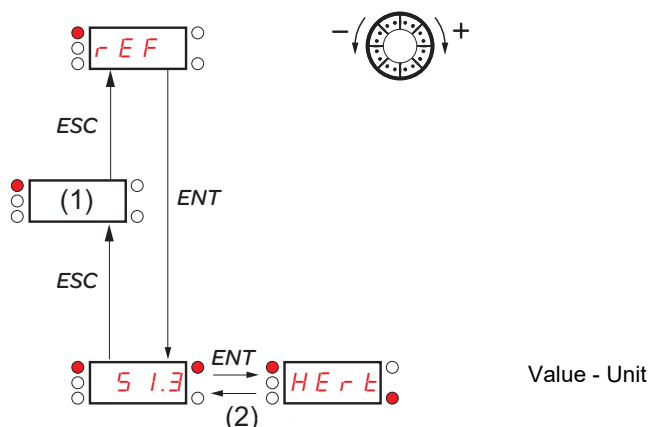

Code	Name/Description	Adjustment range	Factory setting
<p>402</p> <p>(1)</p>	<p><input type="checkbox"/> External reference value</p> <p>Frequency reference visible if reference channel active is remote display. Reference channel 1 401 (page 81) set to 183. or Forced local reference 409 (page 82) set to 183. This parameter allows modification of the frequency reference with the jog dial. Visibility determined by drive settings.</p>	-400 to +400 Hz	-
<p>403</p> <p>(1)</p>	<p><input type="checkbox"/> Integrated display jog dial reference</p> <p>This parameter allows modification of the frequency reference by integrated jog dial. Reference channel 1 401 (page 81) set to 183 or Forced local reference 409 (page 82) set to 183 or PID manual reference 59.18 (page 96) set to 02. Visibility determined by drive settings.</p>	0 to 100% of 512.2 parameter value	-
<p>801</p> <p>01</p> <p>63</p> <p>164</p> <p>183</p>	<p><input type="checkbox"/> Speed reference</p> <p>Actual frequency reference. This parameter is in read-only mode. Visibility determined by drive settings.</p> <ul style="list-style-type: none"> <li><input type="checkbox"/> Analog input terminal</li> <li><input type="checkbox"/> Remote display</li> <li><input type="checkbox"/> Modbus</li> <li><input type="checkbox"/> Integrated display with Jog dial</li> </ul>	512.0 parameter value - 512.2 parameter value	-
<p>59.11</p> <p>(1)</p>	<p><input type="checkbox"/> Internal PID reference value</p> <p>This parameter allows modification of the PID internal reference with the jog dial. Visibility determined by drive settings.</p>	0 to 100%	-
<p>806</p>	<p><input type="checkbox"/> PID reference value value</p> <p>This parameter is the PID reference value expressed as a %.</p>	0 to 100%	-

(1) It is not necessary to press ENT key to confirm modification of the reference.

Parameter that can be modified during operation or when stopped.

# Monitoring mode MOn

When the drive is running, the value displayed is that of one of the monitoring parameters. The default value displayed is the motor **Output frequency 802** (page 49).

While the value of the desired new monitoring parameter is being displayed, press the jog dial button a second time to display the unit.

## Organization tree

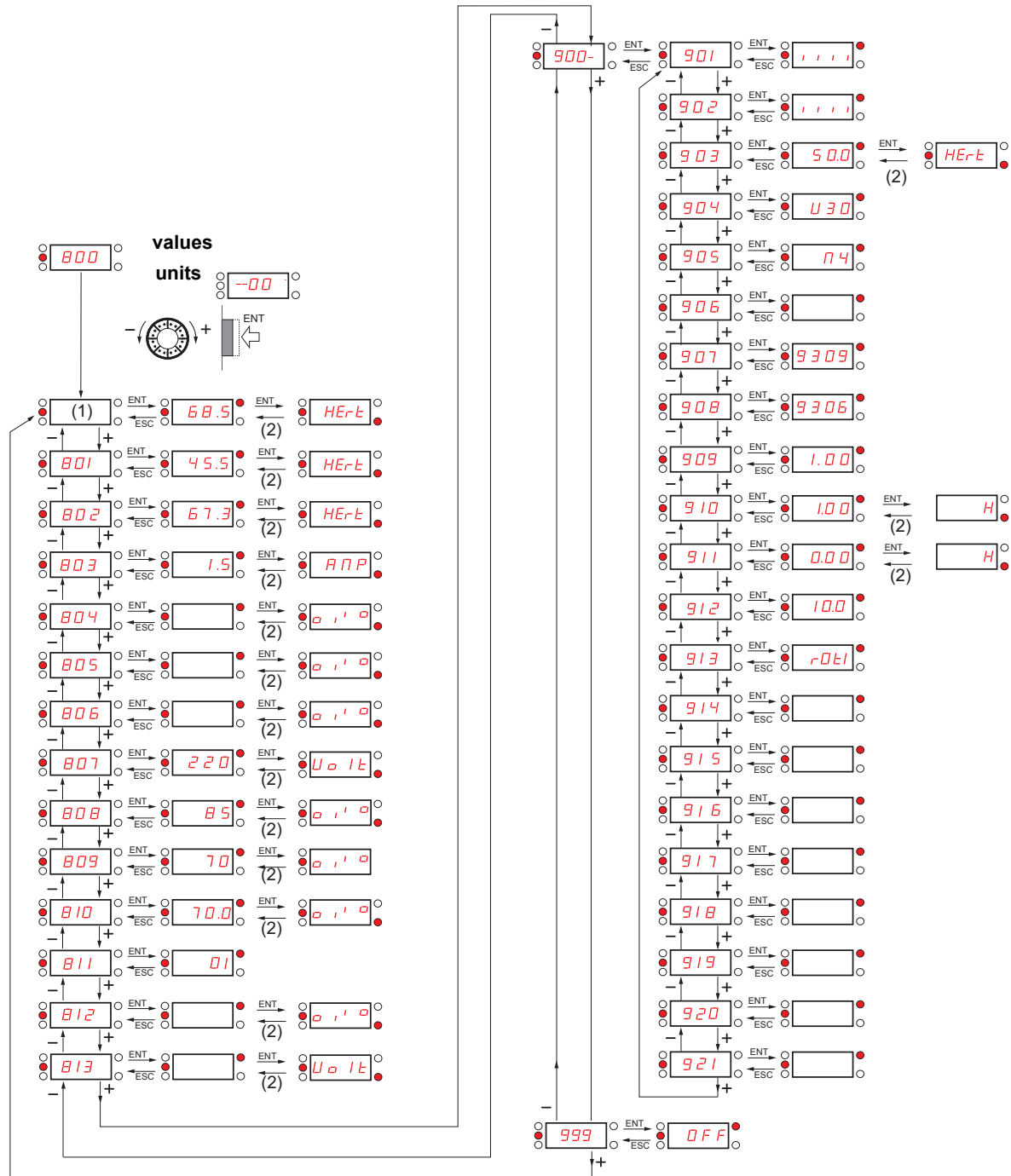

(1) Determined by active reference channel.  
Possible values:

402  
403

(2) 2 s or ESC

Displayed parameter values and units of the diagram are given as examples.

# Monitoring mode MOn

Code	Name/Description	Unit
402 ( )	<input type="checkbox"/> <b>External reference value</b> External display terminal or local force mode configured. <b>Forced local reference 409</b> (page 82) set to <b>163</b> and <b>Forced local assignment 408</b> (page 82) is not <b>00</b> . Displays the Actual speed reference coming from the remote display terminal. This value is not visible in factory setting.	Hz
403 ( )	<input type="checkbox"/> <b>Integrated display jog dial reference</b> Embedded display terminal active or local force mode configured. <b>Forced local reference 409</b> (page 82) set to <b>163</b> and <b>Forced local assignment 408</b> (page 82) is not <b>00</b> . Displays the Actual speed reference coming from the jog dial. This value is not visible in factory setting.	%
801	<input type="checkbox"/> <b>Speed reference</b> Actual frequency reference	Hz
802	<input type="checkbox"/> <b>Output frequency</b> This parameter provides the estimated motor speed. It corresponds to the estimated motor frequency (on the motor shaft). In Standard <b>Motor control type 03</b> (page 69), <b>Output frequency 802</b> is equal to motor stator frequency. In <b>Motor control type 309</b> selection of high performance motor control type <b>00</b> (page 69), <b>Output frequency 802</b> is equal to the frequency corresponding to estimated motor speed. Range: -400 to 400 Hz	Hz
803	<input type="checkbox"/> <b>Motor current</b> Estimation of the effective motor current (output of the drive) from phase current measurements with an accuracy of 5%. During DC injection, the current displayed is the maximum value of current injected in the motor.	A
804	<input type="checkbox"/> <b>PID error</b> Visible only if the PID function is configured [ <b>PID feedback assignment 59.00</b> (page 94) set to <b>01</b> ]. See PID diagram on page 93.	%
805	<input type="checkbox"/> <b>PID feedback</b> Visible only if the PID function is configured [ <b>PID feedback assignment 59.00</b> (page 94) set to <b>01</b> ]. See PID diagram on page 93.	%
806	<input type="checkbox"/> <b>PID reference</b> Visible only if the PID function is configured [ <b>PID feedback assignment 59.00</b> (page 94) set to <b>01</b> ]. See PID diagram on page 93.	%
807	<input type="checkbox"/> <b>Main voltage</b> Line voltage from the point of view of the DC bus, motor running or stopped.	V
808	<input type="checkbox"/> <b>Motor thermal state</b> Display of the motor thermal state. Above 118%, drive displays (page 124) <b>Motor overload F013</b> fault.	%
809	<input type="checkbox"/> <b>Drive thermal state</b> Display of the drive thermal state. Above 118%, drive displays (page 124) <b>Drive overheat F011</b> fault.	%
810	<input type="checkbox"/> <b>Output power</b> The parameter displays the ratio between "estimated motor power (on the shaft) versus drive rating."	%

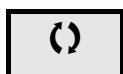

Parameter that can be modified during operation or when stopped.

# Monitoring mode MOn

Code	Name/Description	Unit
<b>B 11</b>	<p><input type="checkbox"/> <b>Product status</b></p> <p>This parameter displays the state of the drive and motor.</p> <ul style="list-style-type: none"> <li><input type="checkbox"/> Drive ready</li> <li><input type="checkbox"/> Drive running, the last 6-segment digit to the right of the code also indicates direction and speed</li> <li><input type="checkbox"/> Acceleration, the last 6-segment digit to the right of the code also indicates direction and speed</li> <li><input type="checkbox"/> Deceleration, the last 6-segment digit to the right of the code also indicates direction and speed</li> <li><input type="checkbox"/> DC injection braking in progress</li> <li><input type="checkbox"/> Current limitation state, 4-segment digit blinks</li> <li><input type="checkbox"/> Freewheel stop control</li> <li><input type="checkbox"/> Auto-adapted deceleration</li> <li><input type="checkbox"/> Controlled stop on mains phase loss</li> <li><input type="checkbox"/> Auto-tuning in progress</li> <li><input type="checkbox"/> Fast stop state</li> <li><input type="checkbox"/> No line power state. When the control part is energized via the RJ45 connector and there is no line voltage and no run order present.</li> <li><input type="checkbox"/> Drive is running and using the Fall back speed</li> <li><input type="checkbox"/> Remote configuration</li> <li><input type="checkbox"/> Local configuration</li> </ul>	
<b>B 12</b>	<p><input type="checkbox"/> <b>Motor torque</b></p> <p>Output torque value (100% = nominal motor torque, estimated value based on current measure).</p>	%
<b>B 13</b>	<p><input type="checkbox"/> <b>Motor voltage</b></p> <p>Motor voltage (estimated value)</p>	V

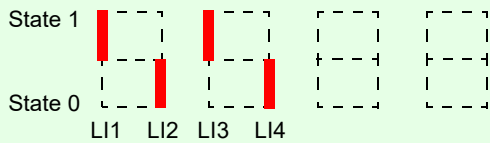
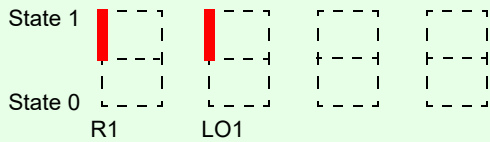
Code	Name/Description	Unit
<b>900-</b>	<b>Maintenance menu</b> Parameters of 900- cannot be selected for monitoring.	
<b>901</b>	<input type="checkbox"/> <b>State of logic inputs LI1 to LI4</b> Can be used to visualize the state of the 4 logic inputs.  <p>Example above: LI1 and LI3 are at 1; LI2 and LI4 are at 0.</p>	-
<b>902</b>	<input type="checkbox"/> <b>State of the logic output LO1 and relay R1</b> Can be used to visualize the state of the logic output. 	-
<b>903</b>	<input type="checkbox"/> <b>Display of high speed value</b> Displays frequency corresponding to the high speed value. Range from <a href="#">Low speed 5 12.0</a> (page <a href="#">109</a> ) to <a href="#">Maximum frequency 308</a> (page <a href="#">69</a> ) is not set to <a href="#">0.6</a> .. Visible only if <a href="#">2 High speed assignment 5 12.3</a> or <a href="#">4 High speed assignment 5 12.4</a> (page <a href="#">110</a> ) is configured.	Hz
<b>904</b>	<input type="checkbox"/> <b>Drive Power rating</b> Indicates the drive power rating. This is part the of the drive reference. Refer to page <a href="#">12</a> . Possible values: 037 = 0.37 kW 075 = 0.75 kW U15 = 1.5 kW U22 = 2.2 kW U30 = 3 kW U40 = 4 kW U55 = 5.5kW U75 = 7.5kW D11 = 11kW D15 = 15 kW D18 = 18.5 kW D22 = 22 kW	-
<b>905</b>	<input type="checkbox"/> <b>Drive voltage rating</b> Indicates the Drive rate voltage. This is part of the drive reference, see page <a href="#">12</a> . Possible values: N4= 360 V~460 V 3-phase in, 360 V~460 V 3-phase out	-
<b>906</b>	<input type="checkbox"/> <b>Specific Product Number</b> This parameter is used to identify the specific version of the product. When the product is in standard version, this parameter value will be 0 and invisible. When the product is in specific or customized version, the value will be non-zero and visible in the menu.	-
<b>907</b>	<input type="checkbox"/> <b>Card 1 Software Version</b> Application software version Example: 1105 for 1.1 ie 05 1 (version, major), 1 (version, minor), 05 (ie, evolution number)	-

Code	Name/Description	Unit												
<b>900 -</b>	<b>Maintenance menu (continued)</b>													
<b>908</b>	<input type="checkbox"/> <b>Card 2 Software Version</b> Motor control software version Example: 1105 for 1.1 ie 05 1 (version, major), 1 (version, minor), 05 (ie, evolution number)	-												
<b>909</b>	<input type="checkbox"/> <b>Run elapsed time display</b> Total time the motor has been powered up. Range: 0 to 65535 hours. Value displayed is as described in the table below. Parameter resettable by services. <table border="1" style="margin-left: 20px;"> <thead> <tr> <th>Hours</th> <th>Display</th> </tr> </thead> <tbody> <tr> <td>1</td> <td>0.01</td> </tr> <tr> <td>10</td> <td>0.10</td> </tr> <tr> <td>100</td> <td>1.00</td> </tr> <tr> <td>1000</td> <td>10.0</td> </tr> <tr> <td>10000</td> <td>100</td> </tr> </tbody> </table>	Hours	Display	1	0.01	10	0.10	100	1.00	1000	10.0	10000	100	0.01
Hours	Display													
1	0.01													
10	0.10													
100	1.00													
1000	10.0													
10000	100													
<b>910</b>	<input type="checkbox"/> <b>Power On time display</b> Total time the drive has been powered on. Range: 0 to 65535 hours. Value displayed is as described in the table above. Parameter resettable by services.	0.01												
<b>911</b>	<input type="checkbox"/> <b>Fan time display</b> Range: 0 to 65535 hours. Value displayed is as described in the table above. Parameter resettable by customer.	0.01												
<b>912</b>	<input type="checkbox"/> <b>Process elapsed time</b> Range: 0 to 65535 hours. Value displayed is as described in the table above. Parameter resettable by customer.	0.01												
<b>( )</b>														
<b>913</b>	<input type="checkbox"/> <b>Modbus communication status</b> <input type="checkbox"/> Modbus no reception, no transmission = communication idle <input type="checkbox"/> Modbus no reception, transmission <input type="checkbox"/> Modbus reception, no transmission <input type="checkbox"/> Modbus reception and transmission	-												
<b>r0t0</b> <b>r0t1</b> <b>r1t0</b> <b>r1t1</b>														
<b>914</b>	<input type="checkbox"/> <b>Last fault 1</b> This parameter describes the Last fault.	-												

**( )** Parameter that can be modified during operation or when stopped.

Code	Name/Description	Unit																														
<b>900 -</b>	<b>Maintenance menu (continued)</b>																															
<b>915</b>	<p><input type="checkbox"/> <b>State of drive at fault 1</b></p> <p>This parameter describes the drive state at the moment of the first detected fault.</p> <table border="1"> <thead> <tr> <th>bit 0</th> <th>bit 1</th> <th>bit 2</th> <th>bit 3</th> <th>bit 4</th> </tr> </thead> <tbody> <tr> <td>ETA.1: Switched on</td> <td>ETA.5: Fast stop</td> <td>ETA.6: Switch on disabled</td> <td>Forced local enabled</td> <td>ETA.15 : Motor rotation in forward direction (or stopped)</td> </tr> <tr> <th>bit 5</th> <th>bit 6</th> <th>bit 7</th> <th>bit 8</th> <th>bit 9</th> </tr> <tr> <td>ETI.4: Run order present</td> <td>ETI.5: DC injection running</td> <td>ETI.7: Motor thermal threshold reached</td> <td>ETI.8: Reserved</td> <td>ETI.9: Product in acceleration</td> </tr> <tr> <th>bit 10</th> <th>bit 11</th> <th>bit 12</th> <th>bit 13 - 14</th> <th>bit 15</th> </tr> <tr> <td>ETI.10 : Product in deceleration</td> <td>ETI.11 : Current limitation or torque limitation is running</td> <td>Fast stop in progress</td> <td>                     ETI.14= 0 + ETI.13=0 : Drive controlled by terminal or local display terminal                      ETI.14= 0 + ETI.13=1 : Drive controlled by remote display terminal                      ETI.14= 1 + ETI.13=0 : Drive controlled by Modbus                      ETI.14= 1 + ETI.13=0 : Reserved                 </td> <td>ETI.15 : Reverse direction applied to the ramp</td> </tr> </tbody> </table>	bit 0	bit 1	bit 2	bit 3	bit 4	ETA.1: Switched on	ETA.5: Fast stop	ETA.6: Switch on disabled	Forced local enabled	ETA.15 : Motor rotation in forward direction (or stopped)	bit 5	bit 6	bit 7	bit 8	bit 9	ETI.4: Run order present	ETI.5: DC injection running	ETI.7: Motor thermal threshold reached	ETI.8: Reserved	ETI.9: Product in acceleration	bit 10	bit 11	bit 12	bit 13 - 14	bit 15	ETI.10 : Product in deceleration	ETI.11 : Current limitation or torque limitation is running	Fast stop in progress	ETI.14= 0 + ETI.13=0 : Drive controlled by terminal or local display terminal ETI.14= 0 + ETI.13=1 : Drive controlled by remote display terminal ETI.14= 1 + ETI.13=0 : Drive controlled by Modbus ETI.14= 1 + ETI.13=0 : Reserved	ETI.15 : Reverse direction applied to the ramp	-
bit 0	bit 1	bit 2	bit 3	bit 4																												
ETA.1: Switched on	ETA.5: Fast stop	ETA.6: Switch on disabled	Forced local enabled	ETA.15 : Motor rotation in forward direction (or stopped)																												
bit 5	bit 6	bit 7	bit 8	bit 9																												
ETI.4: Run order present	ETI.5: DC injection running	ETI.7: Motor thermal threshold reached	ETI.8: Reserved	ETI.9: Product in acceleration																												
bit 10	bit 11	bit 12	bit 13 - 14	bit 15																												
ETI.10 : Product in deceleration	ETI.11 : Current limitation or torque limitation is running	Fast stop in progress	ETI.14= 0 + ETI.13=0 : Drive controlled by terminal or local display terminal ETI.14= 0 + ETI.13=1 : Drive controlled by remote display terminal ETI.14= 1 + ETI.13=0 : Drive controlled by Modbus ETI.14= 1 + ETI.13=0 : Reserved	ETI.15 : Reverse direction applied to the ramp																												
<b>916</b>	<p><input type="checkbox"/> <b>Last fault 2</b></p> <p>This parameter describes the second detected fault.</p>	-																														
<b>917</b>	<p><input type="checkbox"/> <b>State of drive at fault 2</b></p> <p>This parameter describes the drive state at the moment of the second detected fault. See <b>915</b>.</p>	-																														
<b>918</b>	<p><input type="checkbox"/> <b>Last fault 3</b></p> <p>This parameter describes the third detected fault.</p>	-																														
<b>919</b>	<p><input type="checkbox"/> <b>State of drive at fault 3</b></p> <p>This parameter describes the drive state at the moment of the third detected fault. See <b>915</b>.</p>	-																														
<b>920</b>	<p><input type="checkbox"/> <b>Last fault 4</b></p> <p>This parameter describes the fourth detected fault.</p>	-																														
<b>921</b>	<p><input type="checkbox"/> <b>State of drive at fault 4</b></p> <p>This parameter describes the drive state at the moment of the fourth detected fault. See <b>915</b>.</p>	-																														

# Monitoring mode MOn

Code	Name/Description	Adjustment range	Factory setting
<p><b>999</b></p> <p><b>oFF</b></p> <p><b>oN</b></p>	<p><input type="checkbox"/> <b>HMI Password</b></p> <p>Possible state value:</p> <ul style="list-style-type: none"> <li><input type="checkbox"/> Password disabled</li> <li><input type="checkbox"/> Password activated</li> </ul> <p>Range: 2 - 9999</p> <p>If you have lost your password, please contact Schneider Electric.</p> <p>This parameter is used to restrict access to the drive. To lock the drive, go to the <b>HMI Password 999</b> parameter and enter a password within the above range.</p> <p>Once activated, the password state changes to <b>oN</b>: Password protection only enables access to Reference (<b>rEF</b>) (see page 47) mode and Monitor (<b>Boo -</b>) (see page 55) mode. Return to factory settings or access to <b>FULL</b> section are disabled. To unlock the drive, go to the <b>999</b> parameter, enter the valid password, then press ENT. Password protection removal is then possible and carried out by entering <b>oFF</b> using the jog dial and then pressing ENT.</p>	2 - 9999	OFF

# Configuration mode, ConF

The Configuration mode comprises 2 parts :

1. Store/recall parameter set: these 2 functions are used to store and recall customer settings.
2. FULL: This menu permits to access to all other parameters. It includes 6 sub-menus:
  - Macro-configuration **100** (page 57)
  - Input Output menu **200-** (page 58)
  - Motor Control menu **300-** (page 68)
  - Control menu **400-** (page 81)
  - Function menu **500-** (page 83)
  - Fault detection management menu **600-** (page 111)
  - Communication menu **700-** (page 118)

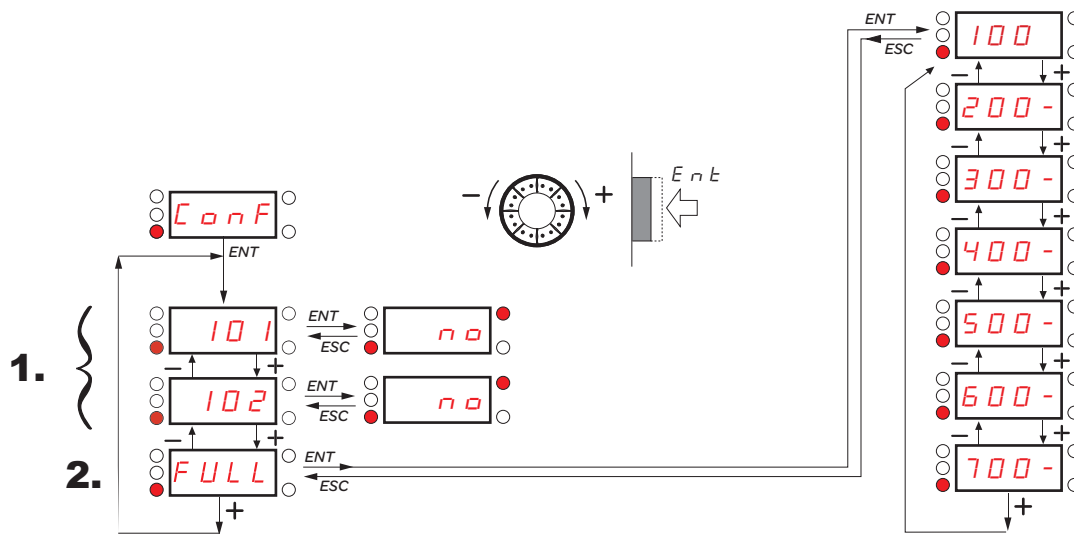

## Organization tree



Displayed parameter values are given as examples only.

(1) Determined by active reference channel. (2) 2 s or ESC  
Possible values: **402** or **403**

# Configuration Mode

Code	Name/Description	Adjustment range	Factory setting
<p><b>101</b></p> <p>00 01</p> <p> 2 s</p>	<p><input type="checkbox"/> <b>Store customer parameter set</b></p> <p>This function creates a backup of the present configuration:</p> <ul style="list-style-type: none"> <li><input type="checkbox"/> Function inactive</li> <li><input type="checkbox"/> Saves the current configuration in the drive memory. <b>101</b> automatically switches to <b>00</b> as soon as the save has been performed.</li> </ul> <p>When a drive leaves the factory the current configuration and the backup configuration are both initialized with the factory configuration.</p>		00
<p><b>102</b></p> <p>00 02 64</p> <p> 2 s</p>	<p><input type="checkbox"/> <b>Factory / recall customer parameter set</b></p> <p>This function permits restoration of a configuration.</p> <ul style="list-style-type: none"> <li><input type="checkbox"/> Function inactive</li> <li><input type="checkbox"/> As soon as one of the following action has been performed, <b>102</b> automatically changes to <b>00</b>.</li> <li><input type="checkbox"/> The current configuration becomes identical to the backup configuration previously saved by <b>101</b>. As soon as this action has been performed, <b>102</b> automatically changes to <b>0002</b> is only visible if the backup has been carried out. If this value appears, <b>64</b> is not visible.</li> <li><input type="checkbox"/> The current configuration becomes identical to the factory setting. If this value appears, <b>64</b> is not visible.</li> </ul> <div style="border: 1px solid black; padding: 5px; text-align: center;"> <p><b>⚠ WARNING</b></p> <p><b>UNANTICIPATED EQUIPMENT OPERATION</b></p> <p>Verify that restoring the factory settings is compatible with the type of wiring used.</p> <p><b>Failure to follow these instructions can result in death, serious injury, or equipment damage.</b></p> </div>		00



To change the assignment of this parameter, press ENT key for 2 s.

## How to control the drive locally

In factory setting, RUN, STOP and jog dial are inactive. To control the drive locally, adjust the following parameters: Set [Reference channel 1 401](#) (page 81) to **183** (use integrated display with jog dial).

## LI assignment information

It is possible with ATV310 to use multi assignment function (ie: **501.4** and **503** on the same LI). It is also possible on some functions to assign LIH (high) or LIL (low), which means that the assigned function will be activated to high (LIH) or low level (LIL) of LI.

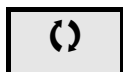

Parameter that can be modified during operation or when stopped.

# Configuration Mode - Complete menu (FULL)

Code	Name/Description	Adjustment range	Factory setting																																																																																												
100	<input type="checkbox"/> Macro-configuration		00																																																																																												
00 04 09	<p><b>⚠ WARNING</b></p> <p><b>UNANTICIPATED EQUIPMENT OPERATION</b> Verify that the selected macro configuration is compatible with the type of wiring used. <b>Failure to follow these instructions can result in death, serious injury or equipment damage.</b></p> <p>Macro configuration provides a shortcut to configure a set of parameters suited to a specific field of application. 3 macro configurations are available:</p> <ul style="list-style-type: none"> <li><input type="checkbox"/> Start/stop. Only forward is assigned.</li> <li><input type="checkbox"/> PID regulation. Activate PID function, dedicate AI1 for feedback and AIV1 for reference.</li> <li><input type="checkbox"/> Speed. Allocate LI to a preset speed which provides a means of configuring speed functions for a specific field of application.</li> </ul> <p>This parameter must be set before performing an autotuning.</p> <p>Selecting a macro configuration assigns the parameters in this macro configuration. Each macro configuration can still be modified in other menus.</p> <table border="1"> <thead> <tr> <th>Input / output or parameter</th> <th>Start/stop</th> <th>PID regulation</th> <th>Speed</th> </tr> </thead> <tbody> <tr> <td>AI1</td> <td>Ref. channel 1</td> <td>PID feedback</td> <td>NONE</td> </tr> <tr> <td>AIV1</td> <td>NONE</td> <td>Ref. channel 1</td> <td></td> </tr> <tr> <td>AO1</td> <td>NONE</td> <td></td> <td></td> </tr> <tr> <td>LO1</td> <td>NONE</td> <td></td> <td></td> </tr> <tr> <td>R1</td> <td>No drive detected fault</td> <td></td> <td></td> </tr> <tr> <td>L1H (2-wire)</td> <td>Forward</td> <td></td> <td></td> </tr> <tr> <td>L2H (2-wire)</td> <td>NONE</td> <td></td> <td>Reverse</td> </tr> <tr> <td>L3H (2-wire)</td> <td>NONE</td> <td>Auto/Manual</td> <td>2 preset speeds</td> </tr> <tr> <td>L4H (2-wire)</td> <td>NONE</td> <td></td> <td>4 preset speeds</td> </tr> <tr> <td>L1H (3-wire)</td> <td>Stop</td> <td></td> <td></td> </tr> <tr> <td>L2H (3-wire)</td> <td>Forward</td> <td></td> <td></td> </tr> <tr> <td>L2H (3-wire)</td> <td>NONE</td> <td></td> <td>Reverse</td> </tr> <tr> <td>L4H (3-wire)</td> <td>NONE</td> <td>Auto/Manual</td> <td>2 preset speeds</td> </tr> <tr> <td>401 (Reference source 1)</td> <td></td> <td>Integrated Jog dial</td> <td>Integrated Jog dial</td> </tr> <tr> <td>404 (Reverse inhibition)</td> <td></td> <td>Yes</td> <td></td> </tr> <tr> <td>204.0 (AI1 type)</td> <td></td> <td>0A</td> <td></td> </tr> <tr> <td>LFL L (4-20 mA signal loss)</td> <td></td> <td>YES</td> <td></td> </tr> <tr> <td>507.3 (Preset speed 2)</td> <td></td> <td></td> <td>10.0Hz</td> </tr> <tr> <td>507.4 (Preset speed 3)</td> <td></td> <td></td> <td>25.0Hz</td> </tr> <tr> <td>507.5 (Preset speed 4)</td> <td></td> <td></td> <td>50.0Hz</td> </tr> <tr> <td>319 (Motor parameter choice)</td> <td></td> <td></td> <td>Motor power factor</td> </tr> <tr> <td>504.0 (Automatic DC injection)</td> <td>Limited DC injection</td> <td>Limited DC injection</td> <td>Limited DC injection</td> </tr> </tbody> </table>			Input / output or parameter	Start/stop	PID regulation	Speed	AI1	Ref. channel 1	PID feedback	NONE	AIV1	NONE	Ref. channel 1		AO1	NONE			LO1	NONE			R1	No drive detected fault			L1H (2-wire)	Forward			L2H (2-wire)	NONE		Reverse	L3H (2-wire)	NONE	Auto/Manual	2 preset speeds	L4H (2-wire)	NONE		4 preset speeds	L1H (3-wire)	Stop			L2H (3-wire)	Forward			L2H (3-wire)	NONE		Reverse	L4H (3-wire)	NONE	Auto/Manual	2 preset speeds	401 (Reference source 1)		Integrated Jog dial	Integrated Jog dial	404 (Reverse inhibition)		Yes		204.0 (AI1 type)		0A		LFL L (4-20 mA signal loss)		YES		507.3 (Preset speed 2)			10.0Hz	507.4 (Preset speed 3)			25.0Hz	507.5 (Preset speed 4)			50.0Hz	319 (Motor parameter choice)			Motor power factor	504.0 (Automatic DC injection)	Limited DC injection	Limited DC injection	Limited DC injection
Input / output or parameter	Start/stop	PID regulation	Speed																																																																																												
AI1	Ref. channel 1	PID feedback	NONE																																																																																												
AIV1	NONE	Ref. channel 1																																																																																													
AO1	NONE																																																																																														
LO1	NONE																																																																																														
R1	No drive detected fault																																																																																														
L1H (2-wire)	Forward																																																																																														
L2H (2-wire)	NONE		Reverse																																																																																												
L3H (2-wire)	NONE	Auto/Manual	2 preset speeds																																																																																												
L4H (2-wire)	NONE		4 preset speeds																																																																																												
L1H (3-wire)	Stop																																																																																														
L2H (3-wire)	Forward																																																																																														
L2H (3-wire)	NONE		Reverse																																																																																												
L4H (3-wire)	NONE	Auto/Manual	2 preset speeds																																																																																												
401 (Reference source 1)		Integrated Jog dial	Integrated Jog dial																																																																																												
404 (Reverse inhibition)		Yes																																																																																													
204.0 (AI1 type)		0A																																																																																													
LFL L (4-20 mA signal loss)		YES																																																																																													
507.3 (Preset speed 2)			10.0Hz																																																																																												
507.4 (Preset speed 3)			25.0Hz																																																																																												
507.5 (Preset speed 4)			50.0Hz																																																																																												
319 (Motor parameter choice)			Motor power factor																																																																																												
504.0 (Automatic DC injection)	Limited DC injection	Limited DC injection	Limited DC injection																																																																																												
⌚ 2 s																																																																																															



To change the assignment of this parameter, press the ENT key for 2 s.

# Configuration Mode - Complete menu (FULL)

200-  
300-  
400-  
500-  
600-  
700-

Code	Name/Description	Adjustment range	Factory setting
<p><b>200 -</b></p> <p><b>201</b></p> <p><b>00</b></p> <p> 2 s</p> <p><b>01</b></p>	<p><b>I/O MENU</b></p> <p><input type="checkbox"/> <b>Type of control</b></p> <p><input type="checkbox"/> 2 wire type control (see page 62) The open or closed state of the input controls running and stopping. Example of "source" wiring:</p> <div data-bbox="432 539 608 689"> </div> <p>LI1: forward LIx: reverse</p> <p><input type="checkbox"/> 3-wire control (see page 62) "Forward" or "reverse" pulse send a run command. A "stop" pulse sends a stop command. Example of "source" wiring:</p> <div data-bbox="432 813 647 963"> </div> <p>LI1: stop LI2: forward LIx: reverse</p> <p>This parameter must be set before performing an autotuning.</p> <div data-bbox="316 1048 1474 1261" style="border: 1px solid black; padding: 5px;"> <p style="text-align: center;"><b>⚠ WARNING</b></p> <p><b>UNANTICIPATED EQUIPMENT OPERATION</b></p> <p>If this parameter is changed, the parameters <b>2-wire type control 202</b> (page 62) and the assignments of the digital inputs are reset to the factory setting. Verify that this change is compatible with the type of wiring used.</p> <p><b>Failure to follow these instructions can result in death, serious injury or equipment damage.</b></p> </div>		<p>00</p>



To change the assignment of this parameter, press the ENT key for 2 s.

## 2 wire type control diagrams (see page 62)

### Level detection diagram with no priority

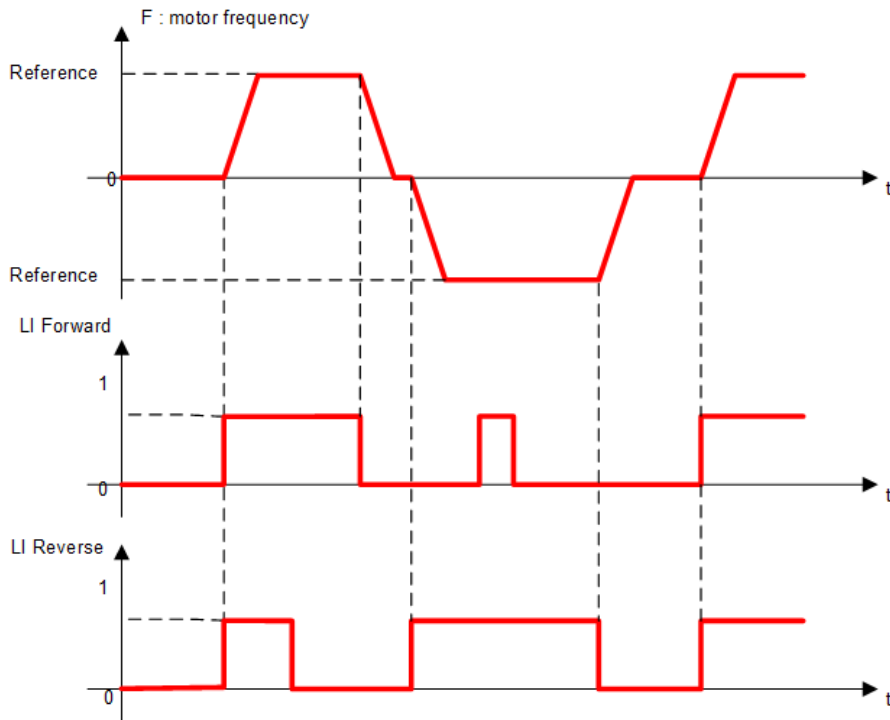

### Level detection diagram with forward priority

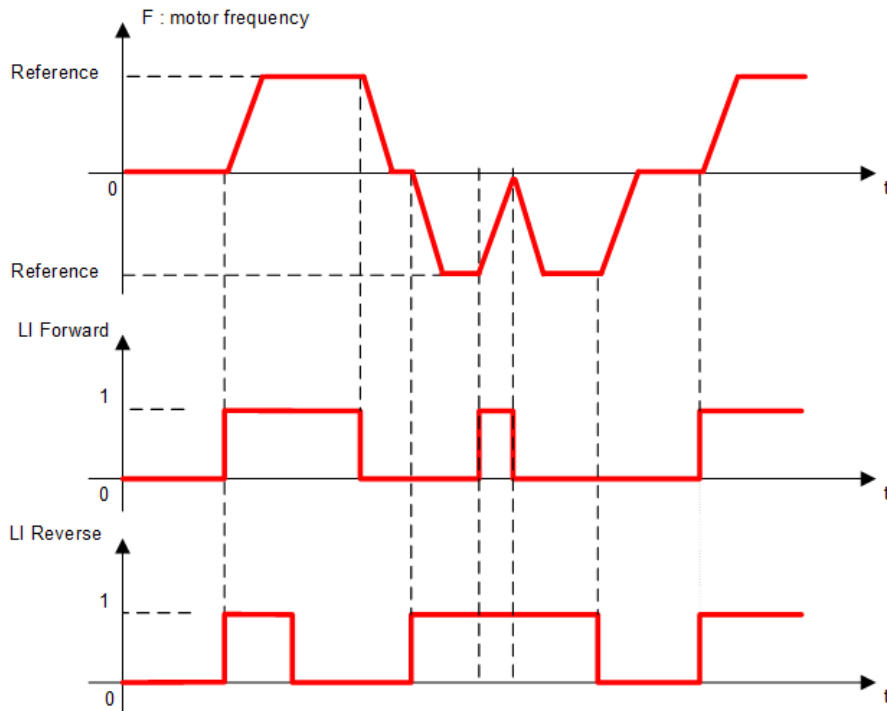

# Configuration Mode - Complete menu (FULL)

---

Transition detection diagram

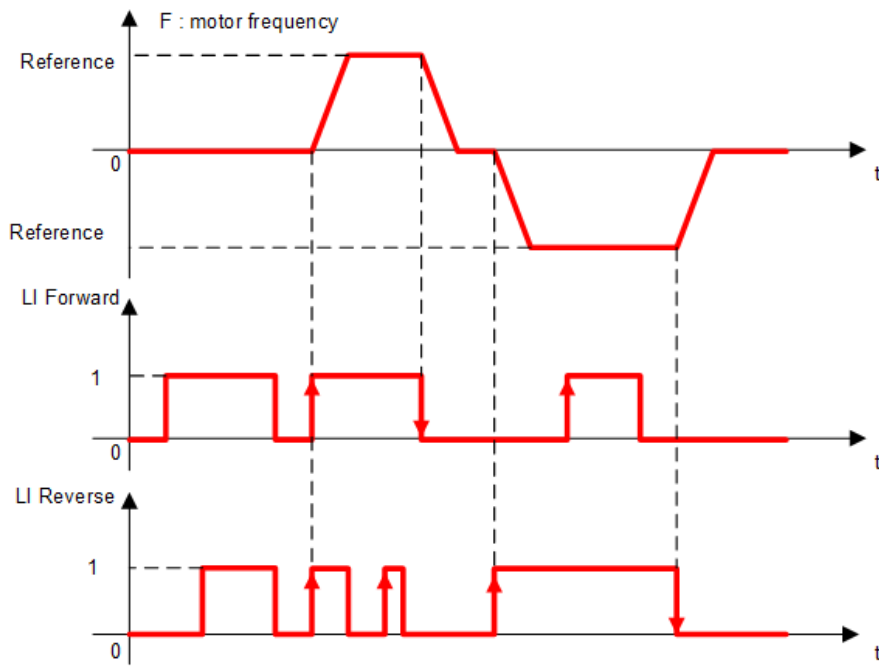

# Configuration Mode - Complete menu (FULL)

200 -  
300 -  
400 -  
500 -  
600 -  
700 -

## 3-wire control diagrams (see page 62)

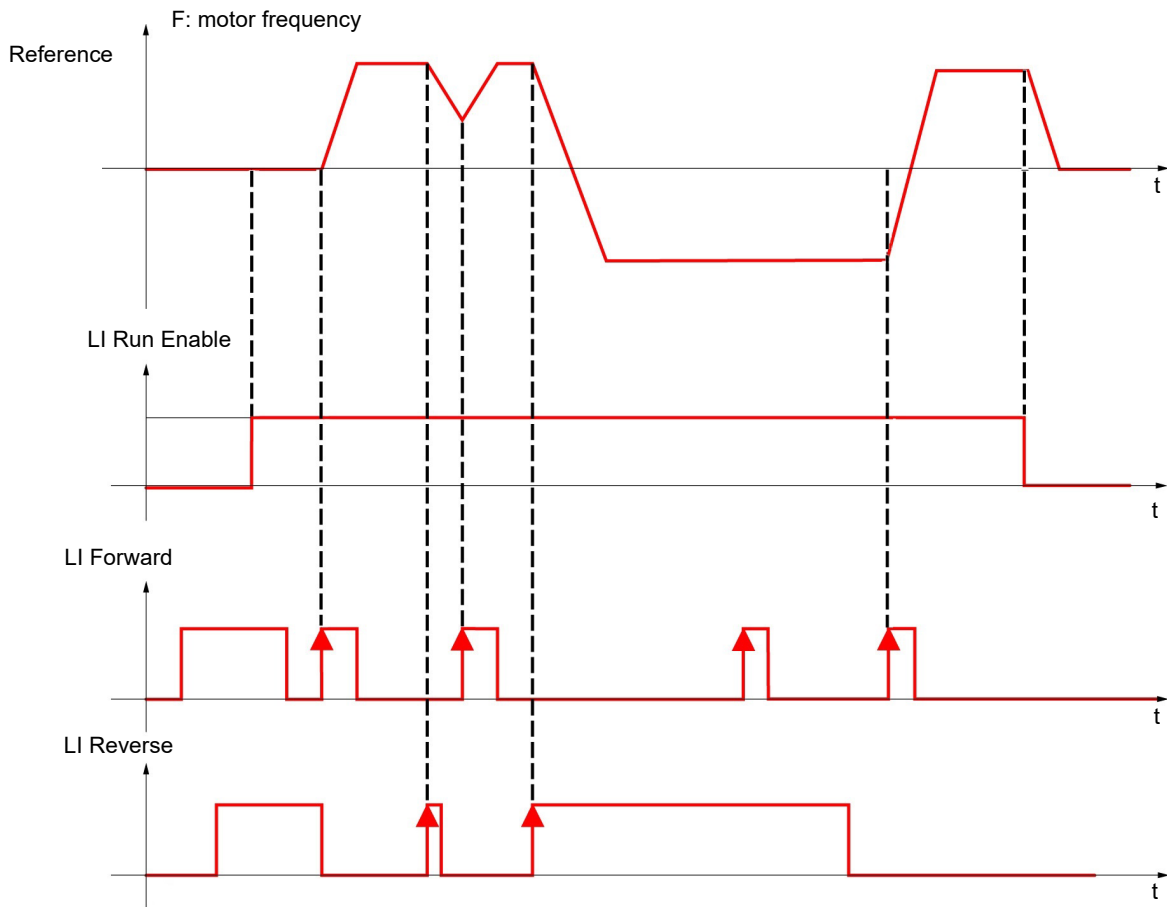

# Configuration Mode - Complete menu (FULL)

200 -  
300 -  
400 -  
500 -  
600 -  
700 -

Code	Name/Description	Adjustment range	Factory setting
<b>200 -</b>	<b>I/O MENU (continued)</b>		
<b>202</b>	<input type="checkbox"/> <b>2-wire type control</b>		01
<b>00</b> <b>01</b> <b>02</b>	<p style="text-align: center;"><b>⚠ WARNING</b></p> <p><b>UNANTICIPATED EQUIPMENT OPERATION</b> Verify that the parameter setting is compatible with the type of wiring used. <b>Failure to follow these instructions can result in death, serious injury or equipment damage.</b></p> <p style="text-align: center;">2-wire type control parameter can only be accessed if <b>Type of control 201</b> (page 58) is set to <b>2C</b>.</p> <ul style="list-style-type: none"> <li><input type="checkbox"/> Level 0/1: Run or stop determined by level state 0 or 1.</li> <li><input type="checkbox"/> Transition: A change of state (transition or edge) is necessary to initiate operation, to help prevent accidental restarts after a power supply interruption.</li> <li><input type="checkbox"/> Priority FW: Run or stop determined by state 0 or 1, but "forward" input takes priority over the "reverse" input.</li> </ul>		
<b>203</b>	<input type="checkbox"/> <b>Logic inputs type</b>		00
<b>00</b> <b>01</b> <b>02</b>	<ul style="list-style-type: none"> <li><input type="checkbox"/> Positive: the inputs are active (state 1) at a voltage equal to or higher than 11 V (for example +24 V terminal). They are inactive (state 0) when the drive is disconnected or at a voltage lower than 5 V.</li> <li><input type="checkbox"/> Negative using internal supply: the inputs are active (state 1) at a voltage lower than 10 V (for example COM terminal). They are inactive (state 0) at a voltage equal to or higher than 16 V or when the drive is disconnected.</li> <li><input type="checkbox"/> Negative using external supply: the inputs are active (state 1) at a voltage lower than 10 V (for example COM terminal). They are inactive (state 0) at a voltage equal to or higher than 16 V.</li> </ul> <p><b>NOTE:</b> The modification will be taken into account only at the next control power-on.</p> <p>See Control connection diagrams on page 37.</p>		

# Configuration Mode - Complete menu (FULL)

200 -  
300 -  
400 -  
500 -  
600 -  
700 -

Code	Name/Description	Adjustment range	Factory setting
200 -	<b>I/O MENU</b> (continued)		
204 -	<b>AI1 CONFIGURATION MENU</b>		
204.0	<input type="checkbox"/> <b>AI1 type</b> This function establishes an interface between the analog input signal and drive internal value. <input type="checkbox"/> Voltage: 0-5 Vdc <input type="checkbox"/> Voltage: 0-10 Vdc <input type="checkbox"/> Current: x-y mA. Range determined by the <b>AI1 current scaling parameter of 0%</b> 204.1 and <b>AI1 current scaling parameter of 100%</b> 204.2 settings below. See page 63. <input type="checkbox"/> Logic input. AI1 must be wired the same way as a logic input Llx in source mode.	5U	
5u 10u 0A L 1u			
204.1	<input type="checkbox"/> <b>AI1 current scaling parameter of 0%</b> Visible only if AI1 type 204.0 is set to 0A.	0 - 20 mA	4 mA
204.2	<input type="checkbox"/> <b>AI1 current scaling parameter of 100%</b> Visible only if AI1 type 204.0 is set to 0A.	0 - 20 mA	20 mA
204.3	<input type="checkbox"/> <b>AI1 filter time</b> Interference filtering cut-off time of the low filter.	0 - 10 s	0 s
200 -	<b>I/O MENU</b> (continued)		
205 -	<b>R1 CONFIGURATION MENU</b>		
205.0	<input type="checkbox"/> <b>R1 assignment</b> <input type="checkbox"/> Not assigned <input type="checkbox"/> No fault <input type="checkbox"/> Drive run <input type="checkbox"/> Frequency threshold reached <input type="checkbox"/> Motor frequency when max. reference value reached 5 12.2 <input type="checkbox"/> I threshold reached <input type="checkbox"/> Frequency reference reached <input type="checkbox"/> Motor thermal threshold reached <input type="checkbox"/> Process underload fault <input type="checkbox"/> Process overload fault <input type="checkbox"/> 4-20 mA signal loss visible only if 204.0 is set to 0A (see above). <b>NOTE:</b> Relay R1 can be assigned to upstream protection to avoid overvoltage in the drive: • Connect fault relay R1 to the contactor, see schematic page 26. • Use Relay R1 (R1 assignment 205.0) with protection. <b>NOTE:</b> When R1 is assigned to Process overload or Process underload fault, the relay will active and last time duration setting by 209 or 2 12.	01	
00 01 02 04 05 06 07 08 21 22 123			
205.1	<input type="checkbox"/> <b>R1 status (output active level)</b> <input type="checkbox"/> Positive logic: active high <input type="checkbox"/> Negative logic: active low		00
00 01			
<b>⚠ WARNING</b>			
<b>LOSS OF CONTROL</b>			
Depending on the assignments and settings of the logic outputs, signal output functions may not be effective if the wiring is incorrect or inoperative.			
<ul style="list-style-type: none"> <li>Do not set this parameter to 01 unless you can ensure that the signal will be available under all circumstances.</li> <li>Verify correct settings for all parameters used to set signal output functions.</li> </ul>			
<b>Failure to follow these instructions can result in death, serious injury or equipment damage.</b>			

# Configuration Mode - Complete menu (FULL)

200 -  
300 -  
400 -  
500 -  
600 -  
700 -

Code	Name/Description	Adjustment range	Factory setting
<b>I/O MENU (continued)</b>			
<b>LO1 CONFIGURATION MENU</b>			
<b>206.0</b>	<input type="checkbox"/> <b>LO1 assignment</b> This parameter is used for a remote indication of the drive status. <input type="checkbox"/> Not assigned <input type="checkbox"/> No fault <input type="checkbox"/> Drive run <input type="checkbox"/> Frequency threshold reached <input type="checkbox"/> Motor frequency when max. reference value reached <b>5 12.2</b> <input type="checkbox"/> I threshold reached <input type="checkbox"/> Frequency reference reached <input type="checkbox"/> Motor thermal threshold reached <input type="checkbox"/> Process underload fault <input type="checkbox"/> Process overload fault <input type="checkbox"/> 4-20 mA signal loss visible only if <b>204.0</b> is set to 0 A (see above). <input type="checkbox"/> Auxiliary pump <b>NOTE:</b> When LO1 is assigned to Process overload or Process underload fault, the logic output will active and last the time duration setting by <b>209</b> or <b>2 12</b> .	00	
00 01 02 04 05 06 07 08 21 22 123 126			
<b>206.1</b>	<input type="checkbox"/> <b>LO1 status (output active level)</b> <input type="checkbox"/> Positive logic: active high <input type="checkbox"/> Negative logic: active low	00	
00 01			
<b>⚠ WARNING</b>			
<b>LOSS OF CONTROL</b> Depending on the assignments and settings of the logic outputs, signal output functions may not be effective if the wiring is incorrect or inoperative. <ul style="list-style-type: none"> <li>Do not set this parameter to 01 unless you can ensure that the signal will be available under all circumstances.</li> <li>Verify correct settings for all parameters used to set signal output functions.</li> </ul> <b>Failure to follow these instructions can result in death, serious injury or equipment damage.</b>			
<b>I/O MENU (continued)</b>			
<b>207</b>	<input type="checkbox"/> <b>Process overload time delay</b> This function can be used to stop the motor in the event of an process overload. This is not a motor or drive thermal overload. If the motor current exceeds the <b>Process overload threshold 208</b> , a <b>Process overload time delay 207</b> is activated. Once this time delay <b>207</b> has elapsed, if the current is still greater than the overload threshold <b>208</b> -10%, the drive will stop running and display Process overload. Overload detection is only active when the system is in steady state (Actual speed reference reached). A value of 0 will disable application overload detection. Estimated motor current Drive stop on detection of <b>F 0 12</b> fault.	0 to 100 s	0 s
<b>208</b> ( )	<input type="checkbox"/> <b>Process overload threshold</b> Visible only if <b>Process overload time delay 207</b> above is not 0. This parameter is used to detect an "application overload". <b>208</b> can be adjusted between 70 and 150% of the rated drive current. This is not the same as a motor or drive thermal overload.	70% - 150% of <b>305</b> parameter value 70% - 150%	90% of <b>305</b> parameter value



Parameter that can be modified during operation or when stopped.

# Configuration Mode - Complete menu (FULL)

200 -  
300 -  
400 -  
500 -  
600 -  
700 -

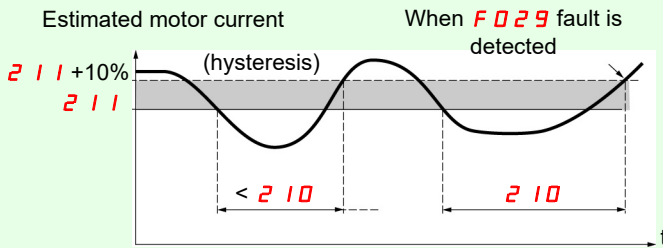
Code	Name/Description	Adjustment range	Factory setting
<b>I/O MENU (continued)</b>			
<b>209</b> ( )	<input type="checkbox"/> <b>Process overload fault duration</b>  If <b>602.0=01</b> , the drive will automatically restart after this time delay following the overload fault <b>F012</b> . Minimum time permitted between an overload being detected and any automatic restart. In order for an automatic restart to be possible, the maximum restart time <b>602.1</b> (page 111) must exceed that of this parameter by at least one minute.  Visible only if the "Overload time delay <b>207</b> " above is not set to 0.	0-6 min.	0 min.
<b>210</b>	<input type="checkbox"/> <b>Process underload time delay</b>  <b>210</b> can be adjust between 0 to 100 s If the motor current undershoots the underload threshold <b>211</b> for longer than the adjustable time delay <b>210</b> , the drive will stop running and display <b>F029</b> (Underload fault), see page 125.  Estimated motor current                      When <b>F029</b> fault is detected  Underload detection is only active when the system is in steady state (Actual speed reference reached). A value of 0 will disable application underload detection.	0 to 100 s	0 s
<b>211</b> ( )	<input type="checkbox"/> <b>Process underload threshold</b>  Visible only if <b>Process underload time delay 210</b> is not set to <b>0</b> . This parameter is used to detect an application underload condition on the motor. <b>Process underload threshold 211</b> can be adjusted between 20 and 100% of the rated drive current.	20% to 100% of 305 parameter	60%
<b>212</b> ( )	<input type="checkbox"/> <b>Process underload fault duration</b>  If <b>602.0=01</b> , the drive will automatically restart after this time delay following the Process underload fault <b>F029</b> . Minimum time permitted between an underload being detected and any automatic restart. In order for an automatic restart to be possible, the maximum restart time <b>602.1</b> (page 111) must exceed that of this parameter by at least one minute.  Visible only if the " <b>Process underload time delay 210</b> " above is not set to 0.	0-6 min.	0 min.
<b>213</b> ( )	<input type="checkbox"/> <b>Motor frequency threshold</b>  Visible only if <b>R1 assignment 205.0</b> (page 63) or <b>LO1 assignment 206.0</b> (page 64) is set to <b>04</b> .	0 to 400 Hz	50 or 60 Hz, Determined by drive rating
<b>214</b> ( )	<input type="checkbox"/> <b>Motor current threshold</b>  Visible only if <b>R1 assignment 205.0</b> (page 63) or <b>LO1 assignment 206.0</b> (page 64) is set to <b>06</b> .	0 to 1.5 In (1)	In
<b>215</b> ( )	<input type="checkbox"/> <b>Motor thermal state threshold</b>  Visible only if <b>R1 assignment 205.0</b> (page 63) is set to <b>0B</b> . Trip threshold for motor thermal alarm (logic output or relay)	0 to 118% of 808 parameter	100%

(1) In = rated drive current

( ) Parameter that can be modified during operation or when stopped.

# Configuration Mode - Complete menu (FULL)

200 -  
300 -  
400 -  
500 -  
600 -  
700 -

Code	Name/Description	Adjustment range	Factory setting
200 -	<b>I/O MENU</b> (continued)		
216 -	<b>AO1 configuration menu</b>		
216.0	<input type="checkbox"/> <b>AO1 assignment</b> This parameter is used to set the value of an analog output. <input type="checkbox"/> Not assigned <input type="checkbox"/> Estimated motor current, between 0 and 2xDrive nominal current <input type="checkbox"/> Estimated motor frequency, between 0 and Maximum Frequency <input type="checkbox"/> Ramp output, between 0 and Maximum Frequency <input type="checkbox"/> PID reference value <sup>(1)</sup> , between 0% and 100% <input type="checkbox"/> PID feedback <sup>(1)</sup> , between 0% and 100% <input type="checkbox"/> PID error <sup>(1)</sup> , between -5% and +5% <input type="checkbox"/> Output power, between 0 and 2xMotor nominal power <input type="checkbox"/> Motor thermal state, between 0% and 200% <input type="checkbox"/> Drive thermal state, between 0% and 200% (1) Visible only if <b>PID feedback assignment 59.00</b> (page 94) is not set to 00.		00
216.1	<input type="checkbox"/> <b>AO1 type</b> This parameter provides type selection for the drive analog output signal. <input type="checkbox"/> Voltage: 0-10 Vdc <input type="checkbox"/> Current: 0-20 mA <input type="checkbox"/> Current: 4-20 mA		0 A

# Configuration Mode - Complete menu (FULL)

200-  
300-  
400-  
500-  
600-  
700-

Code	Name/Description	Adjustment range	Factory setting
200-	<b>I/O MENU (continued)</b>		
217	<input type="checkbox"/> <b>Reference Template</b>		b5d
b5d	<p>This parameter defines how the speed reference is taken into account for analog inputs only. In the case of the PID controller, <b>b n 5</b> and <b>b n 5 0</b> are not applied. The limits are set by the <b>Low Speed 5 12.0</b> and <b>High Speed 5 12.2</b> parameters.</p> <input type="checkbox"/> <b>Standard</b>		At zero reference the frequency = 512.0
b n 5	<input type="checkbox"/> <b>Deadband</b>		At reference = 0 to 512.0 the frequency = 0
b L 5	<input type="checkbox"/> <b>Pedestal</b>		At zero reference to 512.0, the frequency = 512.0
b n 5 0	<input type="checkbox"/> <b>Deadband at 0%</b>		This operation is the same as <b>b 5 d Standard</b> , except that in the following cases at zero reference, the frequency = 0: the signal is less than the minimum value, which is greater than 0 (example: 2 mA on a 4–20 mA input). The signal is greater than maximum value (example: 21 mA on a 20–4 mA input)

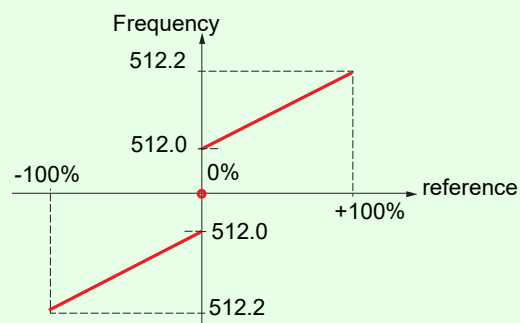
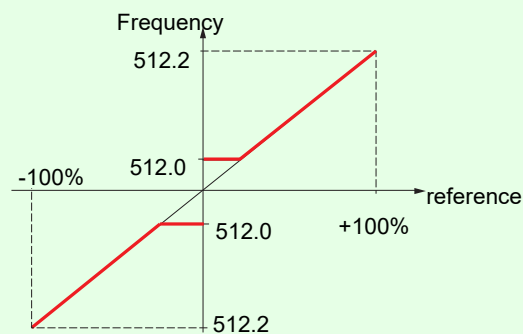
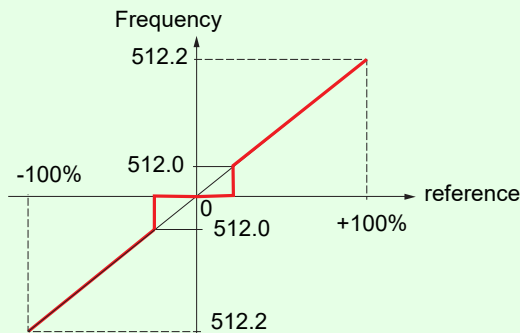
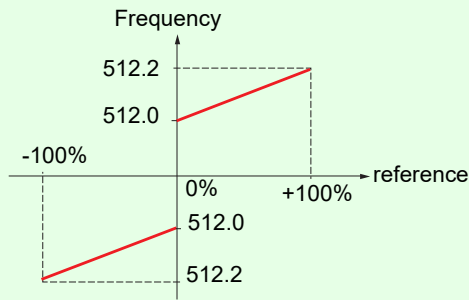

# Configuration Mode - Complete menu (FULL)

200 -  
300 -  
400 -  
500 -  
600 -  
700 -

## ⚠ WARNING

### LOSS OF CONTROL

- Fully read and understand the manual of the connected motor.
- Verify that all motor parameters are correctly set by referring to the nameplate and the manual of the connected motor.
- If you modify the value of one or more motor parameters after having performed auto-tuning, the value of **Auto-tuning** is reset to **00** and you must re-perform auto-tuning.

**Failure to follow these instructions can result in death, serious injury or equipment damage.**

Code	Name/Description	Adjustment range	Factory setting
<b>300 -</b>	<b>Motor control menu</b>		
<b>301</b>	<input type="checkbox"/> <b>Standard motor frequency</b>  This parameter modifies the presets of the following parameters: <b>Rated motor voltage 304</b> below, <b>High speed 512.2</b> (page 110), <b>Motor frequency threshold 213</b> (page 65) and <b>Rated motor frequency 306</b> . <input type="checkbox"/> 50 Hz <input type="checkbox"/> 60 Hz  <b>NOTE:</b> 1. This parameter must be set before performing an autotuning. 2. Modifying this parameter resets the motor tune parameters. Auto-tuning will need to be performed again.	00	
<b>00</b> <b>01</b>			
<b>302</b>	<input type="checkbox"/> <b>Rated motor power</b>  Rated motor power given on the nameplate, in kW if <b>Standard motor frequency 301</b> is set to 50 Hz, in HP if <b>Standard motor frequency 301</b> is set to 60 Hz. Visible only if <b>Motor parameter choice 319</b> (page 72) is set to <b>00</b> and if <b>Motor control type 309</b> (page 69) is not set to <b>05</b> . <b>NOTE:</b> 1. This parameter must be set before performing an autotuning. 2. Modifying this parameter resets the motor tune parameters. Auto-tuning will need to be performed again.	Drive power -5 to drive power +2 according to dual rating	Determined by drive rating and dual rating
<b>303</b>	<input type="checkbox"/> <b>Rated motor cos phi</b>  Visible only if <b>Motor parameter choice 319</b> (page 72) is set to <b>01</b> and if <b>Motor control type 309</b> (page 69) is not set to <b>05</b> . If <b>Rated motor cos phi 303</b> is available, <b>Rated Motor Power 302</b> disappears. Power factor (pf) is given on the motor rating plate.  <b>NOTE:</b> 1. This parameter must be set before performing an autotuning. 2. Modifying this parameter resets the motor tune parameters. Auto-tuning will need to be performed again.  <b>NOTE: Do not confuse this with motor "Service Factor". Setting 303 to 1 or very near to 1 may result in unsatisfactory motor operation. If the motor power factor is not indicated on the nameplate, leave this parameter at the factory default (approximately 0.80).</b>	0.5 to 1	Determined by drive rating and dual rating
<b>304</b>	<input type="checkbox"/> <b>Rated motor voltage</b>  Nominal motor voltage is given on the nameplate. If the line voltage is less than the nominal motor voltage, <b>Rated motor voltage 304</b> should be set to the value of the line voltage applied to the drive terminals. Visible only if <b>Motor control type 309</b> (page 69) is not set to <b>05</b> .  <b>NOTE:</b> 1. This parameter must be set before performing an autotuning. 2. Modifying this parameter resets the motor tune parameters. Auto-tuning will need to be performed again.	360 to 460 V	380 V

(1) In = rated drive current

# Configuration Mode - Complete menu (FULL)

200 -  
300 -  
400 -  
500 -  
600 -  
700 -

Code	Name/Description	Adjustment range	Factory setting
<b>300 -</b>	<b>Motor control menu (continued)</b>		
<b>305</b>	<input type="checkbox"/> <b>Rated motor current</b>  Nominal motor current <b>324.0</b> is given on the nameplate. Motor thermal current <b>604.0</b> (page 114) varies according to the nominal motor current <b>305</b> . Visible only if Motor control type <b>309</b> (page 69) is not set to <b>05</b> .  <b>NOTE:</b> 1. This parameter must be set before performing an autotuning. 2. Modifying this parameter resets the motor tune parameters. Auto-tuning will need to be performed again.	0.25 In to 1.5 In (1)	Determined by drive rating and dual rating
<b>306</b>	<input type="checkbox"/> <b>Rated motor frequency</b>  Nominal motor frequency is given on the nameplate. The factory setting is 50 Hz, or preset to 60 Hz [if Standard motor frequency <b>301</b> (page 68) is set to 60 Hz]. Visible only if Motor control type <b>309</b> (page 69) is not set to <b>05</b> .  <b>NOTE:</b> 1. This parameter must be set before performing an autotuning. 2. Modifying this parameter resets the motor tune parameters. Auto-tuning will need to be performed again.	10 to 400 Hz	50 Hz
<b>307</b>	<input type="checkbox"/> <b>Rated motor speed</b>  Nominal motor speed is given on the nameplate. Visible only if Motor control type <b>309</b> (page 69) is not set to <b>05</b> .  <b>NOTE:</b> 1. This parameter must be set before performing an autotuning. 2. Modifying this parameter resets the motor tune parameters. Auto-tuning will need to be performed again.	0 to 24000 rpm	Determined by drive rating and dual rating
<b>308</b>	<input type="checkbox"/> <b>Maximum frequency</b>  Maximum frequency <b>308</b> gives the upper value possible for High speed <b>512.2</b> (page 110). The factory setting is 60 Hz, or preset to 72 Hz [if Standard motor frequency <b>301</b> (page 68) is set to 60 Hz].  <b>NOTE:</b> 1. This parameter must be set before performing an autotuning. 2. Modifying this parameter resets the motor tune parameters. Auto-tuning will need to be performed again.	10 to 400 Hz	60 Hz
<b>309</b>	<input type="checkbox"/> <b>Motor control type</b>  Permits selection of motor control types suitable for application and performance requirements.		03
<b>00</b>	<input type="checkbox"/> Performance: Sensorless vector control with internal speed loop based on a voltage feedback calculation. For applications requiring high performance during starting or operation.		
<b>03</b>	<input type="checkbox"/> Standard: 2 point V/F control without internal speed loop. For simple applications that do not require high performance. Simple motor control law maintaining a constant Voltage Frequency ratio, permits adjustment of curve start point. This law is generally used for motors connected in parallel. Some applications using motors in parallel or with high performance requirements may require use of the "high performance" ( <b>00</b> ) control type.		
<b>05</b>	<input type="checkbox"/> Sync. motor control (2): For synchronous permanent magnet motors with sinusoidal electromotive force (EMF) only. This selection makes the asynchronous motor parameters inaccessible, and the synchronous motor parameters accessible.		
<b>06</b>	<input type="checkbox"/> Pump: U2/F; for dedicated use with variable torque fan and pump applications not requiring high starting torque.		
	<b>NOTE:</b> 1. This parameter must be set before performing an autotuning. 2. Modifying this parameter resets the motor tune parameters. Auto-tuning will need to be performed again.		

(1) In = rated drive current

(2) This control type is only available for ATV310•••N4S references.

# Configuration Mode - Complete menu (FULL)

200 -  
300 -  
400 -  
500 -  
600 -  
700 -

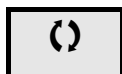

Code	Name/Description	Adjustment range	Factory setting
<b>300 -</b> <b>Motor control menu (continued)</b>			
<b>310</b> ( )	<input type="checkbox"/> <b>IR compensation</b>  Used to optimize torque at very low speed, or to adapt to special cases (for example, for motors connected in parallel, decrease <b>IR compensation 310</b> ). If there is insufficient torque at low speed, increase <b>IR compensation 310</b> . Too high a value can cause the motor not to start (locking) or to change to current limiting mode.	25 to 200%	100%
<b>311</b> ( )	<input type="checkbox"/> <b>Slip compensation</b>  Visible only if <b>Motor control type 309</b> (page 69) is not set to <b>05</b> or <b>06</b> . Used to adjust the slip compensation around the value set by the nominal motor slip, or to adjust to special circumstances (for example, for motors connected in parallel, decrease <b>Slip compensation 311</b> ). If the set slip compensation is lower than the actual slip compensation, the motor will not run at nominal speed in a steady state but at a speed lower than the reference. If the set slip compensation is greater than the actual slip compensation, the motor speed becomes unstable.	0 to 150%	100%
<b>312</b> ( )	<input type="checkbox"/> <b>Frequency loop stability</b>  The <b>Frequency loop stability 312</b> parameter can be used to reduce overshoots and oscillations at the end of acceleration. After a period of acceleration or deceleration, <b>Frequency loop stability 312</b> adjusts the return value of the steady state to the dynamic value of the equipment; Too high a value can cause an extended response time. Too low a value can cause overspeed, or even instability.  Low <b>312</b> parameter value    Correct <b>Frequency loop stability 312</b> parameter value    High <b>Frequency loop stability 312</b> parameter value In this case, increase <b>Frequency loop stability 312</b> In this case, reduce <b>Frequency loop stability 312</b>	0 to 100%	20%
<b>313</b> ( )	<input type="checkbox"/> <b>Frequency loop gain</b>  The <b>313</b> parameter adjusts the slope of the speed increase according to the inertia of the machine being driven. Too high a value can cause overspeed, or even instability. Too low a value can cause an extended response time.  Low <b>313</b> parameter value    Correct <b>313</b> parameter value    High <b>313</b> parameter value In this case, increase <b>313</b> In this case, reduce <b>313</b>	0 to 100%	20%



Parameter that can be modified during operation or when stopped.

# Configuration Mode - Complete menu (FULL)

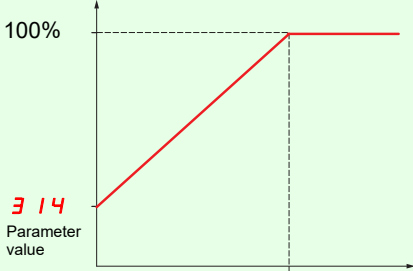
200 -  
300 -  
400 -  
500 -  
600 -  
700 -

Code	Name/Description	Adjustment range	Factory setting
<b>300 -</b>	<b>Motor control menu (continued)</b>		
<b>314</b> 	<input type="checkbox"/> <b>Flux Profile</b> This function defines the magnetizing current at zero frequency as a % of the rated magnetizing current. Adjustment curve for PUMP law  Visible only if <b>Motor control type 309</b> (page 69) is set to <b>06</b> .	0 to 100%	20%
<b>315</b> 	<input type="checkbox"/> <b>Switching frequency</b> Switching frequency range setting. In the event of overheating, the drive automatically decreases the Switching frequency range. Returns to its original value once the temperature has returned to normal.	2 to 12 kHz	4 kHz
<b>317</b>	<input type="checkbox"/> <b>Motor noise reduction</b> Noise refers to audible noise. Means of adjusting motor noise must be provided to satisfy environmental requirements. Random frequency modulation avoids possible noise resonance that can occur at fixed frequency.		00
<b>00</b> <b>01</b>	<input type="checkbox"/> No <input type="checkbox"/> Yes		

 Parameter that can be modified during operation or when stopped.

# Configuration Mode - Complete menu (FULL)

200 -  
**300 -**  
 400 -  
 500 -  
 600 -  
 700 -

Code	Name/Description	Adjustment range	Factory setting
<b>300 -</b>	<b>Motor control menu (continued)</b>		
<b>318</b>	<input type="checkbox"/> <b>Auto-tuning</b>		00
	<p style="text-align: center;"><b>⚠ WARNING</b></p> <p><b>UNEXPECTED MOVEMENT</b>                      Autotuning moves the motor in order to tune the control loops.                      • Only start the system if there are no persons or obstructions in the zone of operation.  <b>Failure to follow these instructions can result in death, serious injury or equipment damage.</b></p> <p>During autotuning, noise development and oscillations of the system are normal.</p> <p style="text-align: center;"><b>⚠ WARNING</b></p> <p><b>LOSS OF CONTROL</b>                      If you modify the value of one or more motor parameters after having performed auto-tuning, the value of <b>Auto-tuning</b> is reset to <b>00</b> and you must re-perform auto-tuning.  <b>Failure to follow these instructions can result in death, serious injury or equipment damage.</b></p> <p> <input type="checkbox"/> No: use factory parameters of standard motors.  <input type="checkbox"/> Yes: request auto-tuning.  <input type="checkbox"/> Done: auto-tuning has already been performed.                 </p> <p><b>Attention:</b></p> <ul style="list-style-type: none"> <li>• Auto-tuning must be performed with the motor connected and cold.</li> <li>• The parameters <b>Rated motor power 302</b> (page 68) and <b>Rated motor current 305</b> (page 69) must be consistent.</li> <li>• Auto-tuning is performed only if no stop command has been activated. If a freewheel stop or fast stop function has been assigned to a logic input, this input must be set to 1 (active at 0).</li> <li>• Auto-tuning takes priority over any run or prefluxing commands, which will take effect after the auto-tuning sequence.</li> <li>• Auto-tuning may last for 1 to 10 seconds. Do not interrupt. Wait for the display to change to <b>02</b> or <b>00</b>.</li> <li>• Re-perform auto-tuning after motor cables are replaced to ensure effectiveness of motor control.</li> </ul> <p> <b>NOTE:</b> During auto-tuning, the motor operates at rated current.</p>		
<b>319</b>	<input type="checkbox"/> <b>Motor parameter choice</b>		00
	<p>This parameter allows to choose which motor parameter will be configured (power or power factor).</p> <p> <input type="checkbox"/> <b>Rated motor power</b> (page 68)  <input type="checkbox"/> <b>Rated motor cos phi</b> (page 68)                 </p> <p><b>NOTE:</b></p> <ol style="list-style-type: none"> <li>1. This parameter must be set before performing an autotuning.</li> <li>2. Modifying this parameter resets the motor tune parameters. Auto-tuning will need to be performed again.</li> </ol>		

**00**  
**01**  
**02**

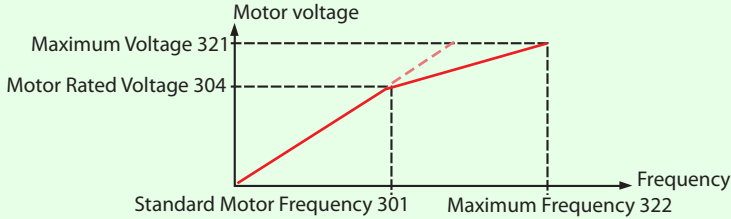

Code	Name/Description	Adjustment range	Factory setting
<b>300 -</b>	<b>Motor control menu (continued)</b>		
<b>320</b> <b>00</b> <b>01</b>	<input type="checkbox"/> <b>Vector control 2 points</b> <input type="checkbox"/> [00] No <input type="checkbox"/> [01] Yes  For use in the following application contexts: when the rated speed and rated frequency of the motor must be exceeded for optimization of operation performance at constant power, or when the maximum voltage of the motor must be limited to a certain value below the main voltage.  The U/F diagram must therefore be modified according to the motor's work ability at maximum voltage and Top frequency.  		00
<b>321</b>	<input type="checkbox"/> <b>Max voltage of constant power</b>  Visible if <b>320</b> = YES	<b>304</b> parameter value ~ 460 V	380 V
<b>322</b>	<input type="checkbox"/> <b>Max frequency of constant power</b>  Visible if <b>320</b> = YES	<b>306</b> parameter value ~ 400Hz	50Hz
<b>323</b>  <b>00</b> <b>01</b>	<input type="checkbox"/> <b>Dual Rating</b>  This parameter is used to select the default value of rated drive current and motor nameplate. This parameter cannot be modified on drive with power equal to or lower than 2.2 kW. A modification of its setting resets several parameters of the drive: - motor nameplate parameters ( <b>302</b> , <b>303</b> , <b>304</b> , <b>305</b> , <b>306</b> , <b>307</b> ) - status of tune results - current parameters: In (drive rating current), motor thermal current ( <b>604.0</b> ), current limitation ( <b>511.1</b> and <b>511.2</b> ), motor current threshold ( <b>214</b> ) and current injections ( <b>502.5</b> , <b>502.7</b> , <b>504.1</b> ).  <input type="checkbox"/> Normal duty: Normal rating, dedicated mode for applications requiring slight overload (up to 1. In for 60 s). <input type="checkbox"/> Heavy duty: High rating, dedicated mode for applications requiring significant overload (up to 1.5In for 60s).  <b>NOTE:</b> 1. This parameter must be set before performing an autotuning. 2. Modifying this parameter resets the motor tune parameters. Auto-tuning will need to be performed again.  <b>NOTE:</b> Both modes use the same hardware, the overload in normal duty is lower than the one in normal duty, consequently, the rated drive current (In) in normal duty mode is adapted to be slightly higher than the one in heavy duty mode. The default motor nameplate and other current limitation are adapted accordingly.		01

# Configuration Mode - Complete menu (FULL)

200 -  
 300 -  
 400 -  
 500 -  
 600 -  
 700 -

Code	Name/Description	Adjustment range	Factory setting
<b>300 -</b>	<b>Motor control menu (continued)</b>		
<b>324 -</b>	<b>Synchronous motor menu</b>		
<b>324.0</b>	<input type="checkbox"/> <b>Nominal motor current</b>  Rated synchronous motor current given on the nameplate.  Visible only if <b>Motor control type 309</b> (page 69) is set to <b>05</b> (Synchronous motor control).	0.25 to 1.5 In (1)	Determined by drive rating and dual rating
<b>324.1</b>	<input type="checkbox"/> <b>Nominal motor torque</b>  Rated motor torque given on the nameplate.  Visible only if <b>Motor control type 309</b> (page 69) is set to <b>05</b> (Synchronous motor control).	0.1 to 6553.5 Nm	Determined by drive rating and dual rating
<b>324.2</b>	<input type="checkbox"/> <b>Nominal motor speed</b>  Rated motor speed given on the nameplate.  Visible only if <b>Motor control type 309</b> (page 69) is set to <b>05</b> (Synchronous motor control).	0 to 48000 rpm	Determined by drive rating
<b>324.3</b>	<input type="checkbox"/> <b>Poles pair number</b>  Number of pairs of poles on the synchronous motor.  Visible only if <b>Motor control type 309</b> (page 69) is set to <b>05</b> (Synchronous motor control).	1 to 50	Determined by drive rating

(1)In = rated drive current

Code	Name/Description	Adjustment range	Factory setting
<b>324 -</b>	<b>Synchronous motor menu (continued)</b>		
<b>318</b>	<input type="checkbox"/> <b>Auto-tuning</b>		00
	 <b>WARNING</b>		
	<b>UNEXPECTED MOVEMENT</b> Autotuning moves the motor in order to tune the control loops. • Only start the system if there are no persons or obstructions in the zone of operation. <b>Failure to follow these instructions can result in death, serious injury or equipment damage.</b>  During autotuning, noise development and oscillations of the system are normal.		
	 <b>WARNING</b>		
	<b>LOSS OF CONTROL</b> If you modify the value of one or more motor parameters after having performed auto-tuning, the value of <b>Auto-tuning</b> is reset to <b>00</b> and you must re-perform auto-tuning. <b>Failure to follow these instructions can result in death, serious injury or equipment damage.</b>		
<b>00</b> <b>01</b> <b>02</b>	<input type="checkbox"/> No: use factory parameters of standard motors. <input type="checkbox"/> Yes: request auto-tuning. <input type="checkbox"/> Done: auto-tuning has already been performed.		
	<b>Attention:</b> <ul style="list-style-type: none"> <li>• Auto-tuning must be performed with the motor connected and cold.</li> <li>• Auto-tuning is performed only if no stop command has been activated. If a freewheel stop or fast stop function has been assigned to a logic input, this input must be set to 1 (active at 0).</li> <li>• Auto-tuning takes priority over any run or prefluxing commands, which will take effect after the auto-tuning sequence.</li> <li>• Auto-tuning may last for 1 to 10 seconds. Do not interrupt. Wait for the display to change to <b>02</b> or <b>00</b>.</li> <li>• Re-perform auto-tuning after motor cables are replaced to ensure effectiveness of motor control.</li> </ul>		
	 <b>NOTE:</b> During auto-tuning, the motor operates at rated current.		
<b>324.4</b>	<input type="checkbox"/> <b>Nominal motor frequency (Read only)</b>	10 to 800 Hz	Calculated by speed and poles
	Nominal motor frequency for synchronous motor in Hz unit. Automatically updated according to <b>Nominal motor speed 324.2</b> and <b>Poles pair number 324.3</b> data.  Visible only if <b>Motor control type 309</b> (page 69) is set to <b>05</b> (Synchronous motor control).		
<b>324.5</b>	<input type="checkbox"/> <b>Sync. EMF constant</b>	0 to 6553.5 mV/rpm	0.0 mV/rpm
	Synchronous motor EMF constant, in mV per rpm (peak voltage per phase). This parameter adjustment allows to reduce the current in operation without load.  Visible only if <b>Motor control type 309</b> (page 69) is set to <b>05</b> (Synchronous motor control).		
<b>324.6</b>	<input type="checkbox"/> <b>% error EMF Sync. (Read only)</b>	-3276.7 to 3275.8 %	-
	Ratio D-Axis Current Use this parameter to adjust <b>Sync. EMF constant 324.5</b> , this parameter value should be closed to 0. If this parameter value is lower than 0%, then <b>Sync. EMF constant 324.5</b> may be increased. If this parameter value is upper than 0%, then <b>Sync. EMF constant 324.5</b> may be reduced.  Visible only if <b>Motor control type 309</b> (page 69) is set to <b>05</b> (Synchronous motor control).		

# Configuration Mode - Complete menu (FULL)

200 -  
 300 -  
 400 -  
 500 -  
 600 -  
 700 -

Code	Name/Description	Adjustment range	Factory setting
<b>300 -</b>	<b>Motor control menu (continued)</b>		
<b>324 -</b>	<b>Synchronous motor menu (continued)</b>		
<b>324.7</b>	<input type="checkbox"/> <b>"d" axis stator inductance</b> Axis "d" stator inductance in mH (per phase). On motors with smooth poles "d" axis stator inductance <b>324.7</b> = "q" axis stator inductance <b>324.8</b> = Stator inductance L. The factory setting is replaced by the result of the auto-tuning operation, if it has been performed.  Visible only if <b>Motor control type 309</b> (page 69) is set to <b>05</b> (Synchronous motor control).	0 to 655.35 mH	0 mH
<b>324.8</b>	<input type="checkbox"/> <b>"q" axis stator inductance</b> Axis "q" stator inductance in mH (per phase). On motors with smooth poles "d" axis stator inductance <b>324.7</b> = "q" axis stator inductance <b>324.8</b> = Stator inductance L. The factory setting is replaced by the result of the auto-tuning operation, if it has been performed.  Visible only if <b>Motor control type 309</b> (page 69) is set to <b>05</b> (Synchronous motor control).	0 to 655.35 mH	0 mH
<b>324.9</b>	<input type="checkbox"/> <b>Calculated stator resistance</b> Cold state stator resistance (per winding). The factory setting is replaced by the result of the auto-tuning operation, if it has been performed. The value can be entered by the user, if he knows it.  Visible only if <b>Motor control type 309</b> (page 69) is set to <b>05</b> (Synchronous motor control).	0 to 65535 mOhm	0 mOhm

Code	Name/Description	Adjustment range	Factory setting
<b>300 -</b>	<b>Motor control menu (continued)</b>		
<b>325 -</b>	<b>Synchronous motor performance menu</b>		
<b>325.0</b>	<input type="checkbox"/> <b>Saliency motor state (Read only)</b>  Information on synchronous motor saliency. <b>NOTE:</b> In case of motor with low saliency, the standard control law is advised.		01
<b>00</b>	<input type="checkbox"/> No: Tune not done.		
<b>01</b>	<input type="checkbox"/> Low salient: Low saliency level (Recommended configuration: <b>Auto angle setting type 325.1</b> = [PSI align] (05) or [PSIO align] (06).		
<b>02</b>	<input type="checkbox"/> Med salient: Medium saliency level ( <b>Auto angle setting type 325.1</b> = [SPM align] (04) is possible).		
<b>03</b>	<input type="checkbox"/> High salient: High saliency level ( <b>Auto angle setting type 325.1</b> = [IPM align] (03) is possible).		
	Visible only if <b>Motor control type 309</b> (page 69) is set to <b>05</b> (Synchronous motor control).		
<b>325.1</b>	<input type="checkbox"/> <b>Auto angle setting type</b>  Mode for measuring the phase-shift angle. [PSI align] (05) and [PSIO align] (06) are working for all type of synchronous motors. [SPM align] (04) and [IPM align] (03) increase performances depending on the type of synchronous motor.		06
<b>03</b>	<input type="checkbox"/> IPM align: Alignment for IPM motor. Alignment mode for Interior-buried Permanent Magnet motor (usually, this kind of motor has a high saliency level). It uses high frequency injection, which is less noisy than standard alignment mode.		
<b>04</b>	<input type="checkbox"/> SPM align: Alignment for SPM motor. Mode for Surface-mounted Permanent Magnet motor (usually, this kind of motor has a medium or low saliency level). It uses high frequency injection, which is less noisy than standard alignment mode.		
<b>05</b>	<input type="checkbox"/> PSI align: Pulse signal injection. Standard alignment mode by pulse signal injection.		
<b>06</b>	<input type="checkbox"/> PSIO align: Pulse signal injection - Optimized. Standard optimized alignment mode by pulse signal injection. The phase shift angle measurement time is reduced after the first run order or tune operation, even if the drive has been turned off.		
<b>254</b>	<input type="checkbox"/> No align: No alignment.		
	Visible only if <b>Motor control type 309</b> (page 69) is set to <b>05</b> (Synchronous motor control).		
<b>325.2</b>	<input type="checkbox"/> <b>Speed filter coefficient</b>  Speed filter coefficient (0(IP) to 100(PI)). The speed reference value is filtered upstream to the speed loop. This parameter allows the configuration of this filter:	0 to 100	65
	<ul style="list-style-type: none"> <li>• 0 (e.g. 0 %), the speed reference value is completely filtered: for applications requiring flexibility and stability.</li> <li>• 100 (e.g. 100 %), the speed reference value is not filtered: for applications requiring short time response.</li> <li>• 65 (default value), the speed reference value is filtered at 65 %.</li> </ul>		
	Visible only if <b>Motor control type 309</b> (page 69) is set to <b>05</b> (Synchronous motor control).		
<b>325.3</b>	<input type="checkbox"/> <b>Current reference filter time</b>  Filter time of the current reference filter.	0 to 100 ms	3.2 ms
	Visible only if <b>Motor control type 309</b> (page 69) is set to <b>05</b> (Synchronous motor control).		

# Configuration Mode - Complete menu (FULL)

200 -  
300 -  
400 -  
500 -  
600 -  
700 -

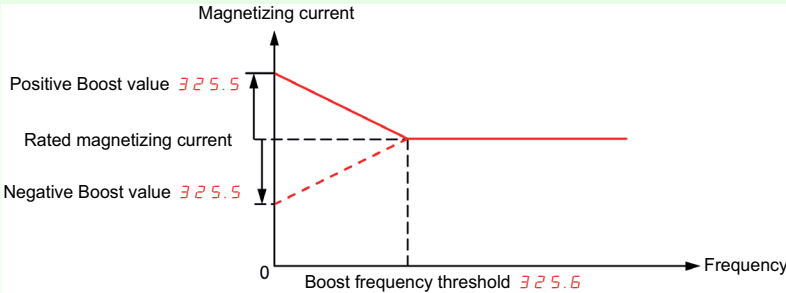
Code	Name/Description	Adjustment range	Factory setting
<b>300 -</b>	<b>Motor control menu (continued)</b>		
<b>325 -</b>	<b>Synchronous motor performance menu (continued)</b>		
<b>325.4</b>  00 01 02	<input type="checkbox"/> <b>Boost activation</b>  <input type="checkbox"/> Inactive: No boost. <input type="checkbox"/> Dynamic: Dynamic boost. <input type="checkbox"/> Static: Static boost.  Visible only if <b>Motor control type 309</b> (page 69) is set to <b>05</b> (Synchronous motor control).		01
<b>325.5</b>	<input type="checkbox"/> <b>Boost value</b>  This parameter can be accessed if <b>Boost activation 325.4</b> is not set to <b>00</b> . Adjustment of the motor magnetizing current at low speed, as a % of the rated magnetizing current. This parameter is used to increase or reduce the time taken to establish the torque. It allows gradual adjustment up to the frequency set by <b>Boost frequency threshold 325.6</b> . Negative values apply particularly to tapered rotor motors.  	-100 to 100 %	0 %
<b>325.6</b>	<input type="checkbox"/> <b>Boost frequency threshold</b>  This parameter can be accessed if <b>Boost activation 325.4</b> is not set to 00. Frequency above which the magnetizing current is no longer affected by <b>Boost value 325.5</b> .  Visible only if <b>Motor control type 309</b> (page 69) is set to <b>05</b> (Synchronous motor control).	0 to 400 Hz	0 Hz
<b>325.7</b>	<input type="checkbox"/> <b>Maximum current of PSI alignment</b>  Current level in % of <b>Nominal motor current 324.0</b> for [PSI align] (05) and [PSIO align] (06) angle shift measurement modes. This parameter has an impact on the inductor measurement and is used for tune operation. This current must be equal or higher than the maximum current level of the application, otherwise instability may occur.  Visible only if <b>Motor control type 309</b> (page 69) is set to <b>05</b> (Synchronous motor control).	0 to 300 %	0 %
<b>325.8</b>  00 01 02 03 04	<input type="checkbox"/> <b>Autotune status (Read only)</b>  This parameter is not saved at drive power off. It shows the Autotuning status since last power on. <input type="checkbox"/> Not done: Autotune is not done <input type="checkbox"/> Pending: Autotune has been requested but not yet performed <input type="checkbox"/> In Progress: Autotune is in progress <input type="checkbox"/> Failed: Autotune has detected a fault <input type="checkbox"/> Done: The motor parameters measured by the auto-tuning function are used to control the motor  Visible only if <b>Motor control type 309</b> (page 69) is set to <b>05</b> (Synchronous motor control).		00

# Configuration Mode - Complete menu (FULL)

200 -  
**300 -**  
 400 -  
 500 -  
 600 -  
 700 -

Code	Name/Description	Adjustment range	Factory setting
<b>300 -</b>	<b>Motor control menu (continued)</b>		
<b>327</b>	<input type="checkbox"/> <b>Frequency reference high resolution enable</b>		00
<b>00</b> <b>01</b>	<p>This parameter adjusts the resolution of the frequency reference and supports saving after power loss. This function has no effect on the speed reference or output speed.</p> <ul style="list-style-type: none"> <li><input type="checkbox"/> Standard resolution: The resolution of the frequency reference is 0.1Hz.</li> <li><input type="checkbox"/> High resolution: Standardized value 16 signed bits based on the maximum frequency. The value 32767 corresponds to <b>Maximum frequency 308</b> (page 69) . The default value of <b>Maximum frequency 308</b> (page 69) is 60 Hz, and the resolution is then approximately 0.0018 Hz.</li> </ul>		

# Configuration Mode - Complete menu (FULL)

200 -  
300 -  
400 -  
500 -  
600 -  
700 -

## Control menu

### Control channel diagram

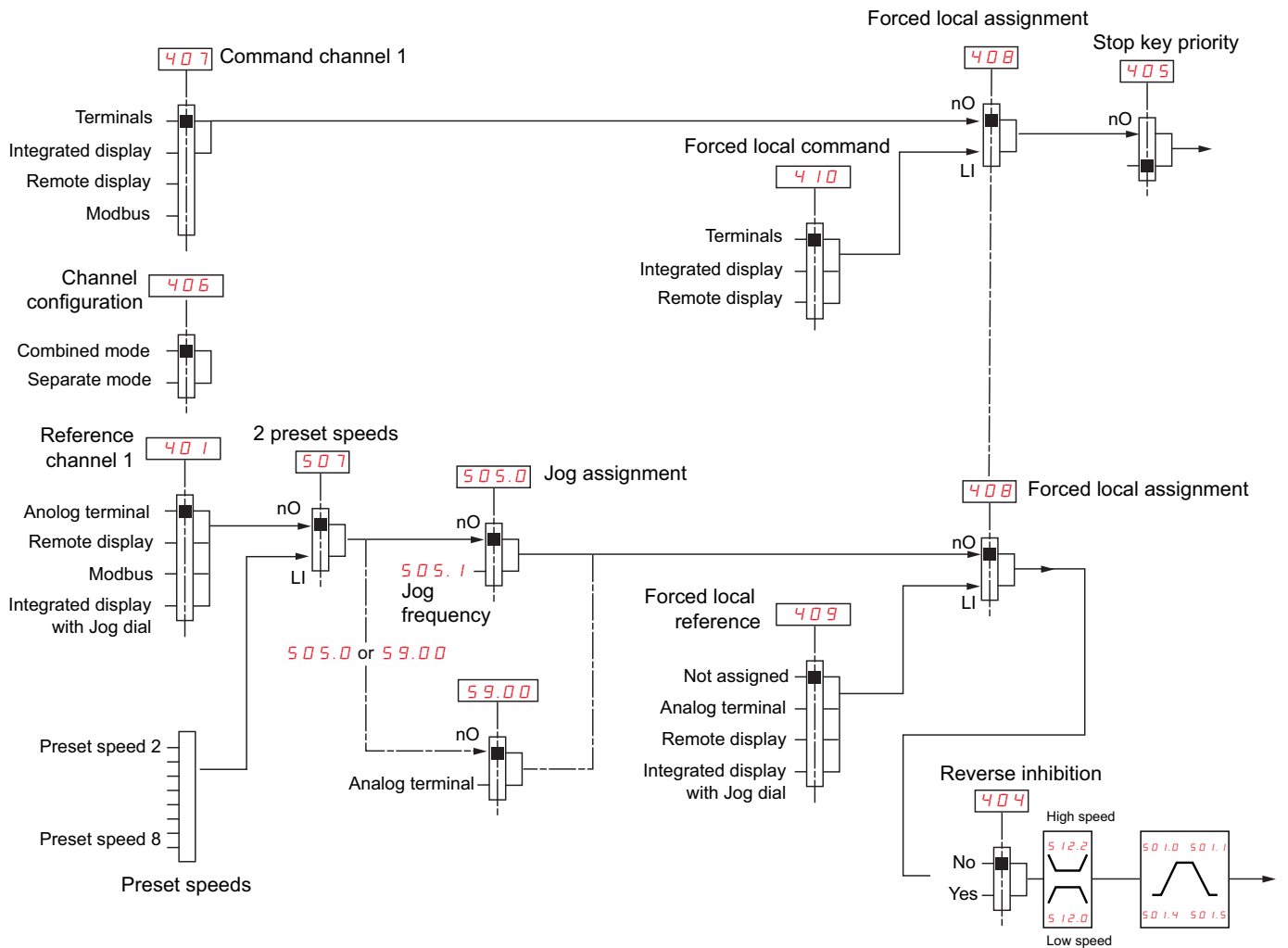

Code	Name/Description	Adjustment range	Factory setting
<b>400 -</b>	<b>Control menu</b>		
<b>401</b> 01 163 164 183	<input type="checkbox"/> <b>Reference channel 1</b>  <input type="checkbox"/> Analog terminal <input type="checkbox"/> Remote display <input type="checkbox"/> Modbus <input type="checkbox"/> Integrated display with Jog dial		01
<b>402</b> ( )	<input type="checkbox"/> <b>External reference value</b>	-400 Hz to 400 Hz	-
<b>403</b> ( )	<input type="checkbox"/> <b>Integrated display jog dial reference</b>  Embedded display terminal active or local force mode configured. <b>Forced local reference 409</b> set to <b>183</b> and <b>Forced local assignment 408</b> is not set to <b>00</b> . Displays the Actual speed reference coming from the jog dial. This value is not visible in the factory settings.	0% to 100% of <b>512.2</b> parameter value	
<b>404</b>  00 01	<input type="checkbox"/> <b>Reverse inhibition</b>  Inhibition of movement in the reverse direction. Does not apply to direction requests sent by logic inputs. - Reverse direction requests sent by logic inputs are taken into account. - Reverse direction requests sent by the display are not taken into account. - Reverse direction requests sent by the communication line are not taken into account. - Any reverse Actual speed reference originating from the PID, summing input etc., is interpreted as a zero reference (0 Hz).  <input type="checkbox"/> No <input type="checkbox"/> Yes		00
<b>405</b>  2 s	<input type="checkbox"/> <b>Stop key priority</b>  This parameter can enable or disable the stop button located on the drive and remote display. Disabling the stop button is effective if the active command channel is not the drive display terminal or the remote display.  <div style="text-align: center;"><b>⚠ WARNING</b></div> <div style="border: 1px solid black; padding: 5px;"> <b>LOSS OF CONTROL</b>                      The function Stop key priority 405 parameter disables the Stop keys of the drive and of the Remote Display Terminal if the setting of the parameter is 00.                      Only set this parameter to 00 if you have implemented appropriate alternative stop functions.  <b>Failure to follow these instructions can result in death, serious injury or equipment damage.</b> </div> <input type="checkbox"/> No: Stop inactive <input type="checkbox"/> Yes: Stop active It is advised in case this function is set to <b>01</b> to use the front door cover or the optional display cover on the "run" and "stop" keys.		01
<b>406</b>  01 02	<input type="checkbox"/> <b>Channel configuration</b>  Channel configuration <b>406</b> allows the selection of: - Combined mode (command and reference come from the same channel) - Separate mode (command and reference come from different channels)  <input type="checkbox"/> Combined mode <input type="checkbox"/> Separate mode		01



To change the assignment of this parameter, press the ENT key for 2 s.

Parameter that can be modified during operation or when stopped.

# Configuration Mode - Complete menu (FULL)

200-  
300-  
400-  
500-  
600-  
700-

Code	Name/Description	Adjustment range	Factory setting
<b>400-</b>	<b>Control menu (continued)</b>		
<b>407</b>	<input type="checkbox"/> <b>Command channel 1</b>  This parameter permits selection of the command channel.  <input type="checkbox"/> Terminals <input type="checkbox"/> Integrated display <input type="checkbox"/> Remote display <input type="checkbox"/> Modbus Visible only if Channel configuration <b>406</b> (page <a href="#">81</a> ) is set to Seperate.		01
01 02 03 10			
<b>408</b>	<input type="checkbox"/> <b>Forced local assignment</b>  <input type="checkbox"/> Not assigned <input type="checkbox"/> L1H: LI1 active high <input type="checkbox"/> L2H: LI2 active high <input type="checkbox"/> L3H: LI3 active high <input type="checkbox"/> L4H: LI4 active high <input type="checkbox"/> LUH: LIU active high		00
00 L1H L2H L3H L4H LUH			
<b>409</b>	<input type="checkbox"/> <b>Forced local reference</b>  Visible only if Forced local assignment <b>408</b> is not set to <b>00</b>  <input type="checkbox"/> Not assigned <input type="checkbox"/> Analog terminal <input type="checkbox"/> Remote display <input type="checkbox"/> Integrated display with Jog dial		00
00 01 163 183			
<b>410</b>	<input type="checkbox"/> <b>Forced local command</b>  Visible only if Forced local assignment <b>408</b> is not set to <b>00</b>  <input type="checkbox"/> Terminals <input type="checkbox"/> Integrated display <input type="checkbox"/> Remote display		02
01 02 03			

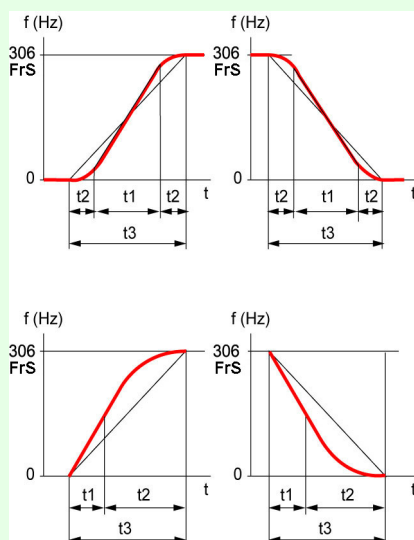
Code	Name/Description	Adjustment range	Factory setting
<b>500 -</b>	<b>Function menu</b>		
<b>501 -</b>	<b>Ramp menu</b>		
<b>501.0</b> ( )	<input type="checkbox"/> <b>Acceleration</b> For asynchronous motor, acceleration time between 0 Hz and the <b>Rated motor frequency 306</b> (page 69). For synchronous motor, acceleration time between 0 Hz and the <b>Nominal motor frequency 324.4</b> (page 75). Make sure this value is compatible with the inertia being driven.	0.0 s to 999.9 s	3.0 s
<b>501.1</b> ( )	<input type="checkbox"/> <b>Deceleration</b> For asynchronous motor, time to decelerate from the <b>Rated motor frequency 306</b> (page 69) to 0 Hz. For synchronous motor, time to decelerate from the <b>Nominal motor frequency 324.4</b> (page 75) to 0 Hz. Make sure this value is compatible with the inertia being driven.	0.0 s to 999.9 s	3.0 s
<b>501.2</b> 00 01 02 ( )	<input type="checkbox"/> <b>Ramp shape assignment</b> <input type="checkbox"/> Linear <input type="checkbox"/> S Shape <input type="checkbox"/> U Shape  <p>The rounding coefficient is fixed, wherein  <math>t1 = 0.6 \times \text{set ramp time (linear)}</math>  <math>t2 = 0.4 \times \text{set ramp time (round)}</math>  <math>t3 = 1.4 \times \text{ramp time}</math></p> <p>The rounding coefficient is fixed, wherein  <math>t1 = 0.5 \times \text{set ramp time (linear)}</math>  <math>t2 = \text{set ramp time (round)}</math>  <math>t3 = 1.5 \times \text{ramp time}</math></p>		00
<b>501.3</b> 00 L1H L2H L3H L4H L1L L2L L3L L4L LUL	<input type="checkbox"/> <b>Ramp switching commutation</b> <input type="checkbox"/> Not assigned <input type="checkbox"/> L1H: LI1 active high <input type="checkbox"/> L2H: LI2 active high <input type="checkbox"/> L3H: LI3 active high <input type="checkbox"/> L4H: LI4 active high <input type="checkbox"/> LUH: LIU active high <input type="checkbox"/> L1L: LI1 active low <input type="checkbox"/> L2L: LI2 active low <input type="checkbox"/> L3L: LI3 active low <input type="checkbox"/> L4L: LI4 active low <input type="checkbox"/> LUL: LIU active low See LI assignment information on page 56.		00

( ) Parameter that can be modified during operation or when stopped.

# Configuration Mode - Complete menu (FULL)

200 -  
300 -  
400 -  
500 -  
600 -  
700 -

Code	Name/Description	Adjustment range	Factory setting
<b>500 -</b>	<b>Function menu (continued)</b>		
<b>501 -</b>	<b>Ramp menu (continued)</b>		
<b>501.4</b> ( )	<input type="checkbox"/> <b>Acceleration 2</b>  Visible only if <b>Ramp switching commutation 501.3</b> (page 83) is not set to <b>00</b> . Second acceleration ramp time, adjustable from 0.0 to 999.9 s This ramp becomes the active ramp only when PID is used to perform start and wake-up phases. See PID: <b>wake up level</b> (page 97).	0.0 to 999.9 s	5.0 s
<b>501.5</b> ( )	<input type="checkbox"/> <b>Deceleration 2</b>  Visible only if <b>Ramp switching commutation 501.3</b> (page 83) is not set to <b>00</b> . Second deceleration ramp time, adjustable from 0.0 to 999.9 s	0.0 to 999.9 s	5.0 s
<b>501.6</b> <b>00</b> <b>01</b> <b>02</b>	<input type="checkbox"/> <b>Decel Ramp Adaptation assignment</b>  <input type="checkbox"/> Function inactive. The drive will decelerate based on normal deceleration time settings. This setting is compatible with optional dynamic braking (if used). <input type="checkbox"/> This function automatically increases deceleration time when stopping or reducing the speed of high inertia loads to help prevent DC bus overvoltage or overbraking. <input type="checkbox"/> Motor Braking: This mode allows the drive to attempt the most rapid stop possible without the use of a dynamic brake resistor. It uses motor losses to dissipate energy generated by braking. This function may be incompatible with positioning. This function should not be used when an optional braking resistor and module are being used.  <b>Attention: When using a braking resistor set 501.6 to 00.</b>		01

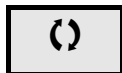

Parameter that can be modified during operation or when stopped.

# Configuration Mode - Complete menu (FULL)

200 -  
300 -  
400 -  
500 -  
600 -  
700 -

Code	Name/Description	Adjustment range	Factory setting
<b>500 -</b>	<b>Function menu (continued)</b>		
<b>502 -</b>	<b>Stop configuration menu</b>		
<b>502.0</b>	<input type="checkbox"/> <b>Type of stop</b> Stop mode on disappearance of the run command or appearance of a stop command. <input type="checkbox"/> Ramp stop <input type="checkbox"/> DC injection stop. Available only if <b>Motor control type 309</b> (page 69) is not set to <b>05</b> . <input type="checkbox"/> Fast stop <input type="checkbox"/> Freewheel stop		00
00 03 08 13			
<b>502.1</b>	<input type="checkbox"/> <b>Freewheel stop assignment</b> This stop type is activated when the input or corresponding register bit changes to 0. If the input returns to state 1 and the run command is still active, the motor will only restart if <b>Type of control 201</b> (page 58) = <b>2C</b> and <b>2-wire type control 202</b> (page 62) = <b>00</b> or <b>02</b> . If not, a new run command must be sent. <input type="checkbox"/> Not assigned <input type="checkbox"/> L1L: L1 active Low to stop <input type="checkbox"/> L2L: L2 active Low to stop <input type="checkbox"/> L3L: L3 active Low to stop <input type="checkbox"/> L4L: L4 active Low to stop <input type="checkbox"/> LUL: LIU active Low to stop		00
00 L1L L2L L3L L4L LUL			
<b>502.2</b>	<input type="checkbox"/> <b>Fast stop assignment</b> <input type="checkbox"/> Not assigned <input type="checkbox"/> L1L: L1 active Low to stop <input type="checkbox"/> L2L: L2 active Low to stop <input type="checkbox"/> L3L: L3 active Low to stop <input type="checkbox"/> L4L: L4 active Low to stop <input type="checkbox"/> LUL: LIU active Low to stop		00
00 L1L L2L L3L L4L LUL			
<b>502.3</b>	<input type="checkbox"/> <b>Fast stop Ramp divider</b> Visible only if <b>Fast stop assignment 502.2</b> (page 85) is not set to <b>00</b> or <b>502.0</b> is set to <b>08</b> Fast stop (page 85). When stop requests are sent the active ramp time [ <b>Deceleration 501.1</b> (page 83) or <b>Deceleration 2 501.5</b> (page 84)] is divided by this coefficient.	1 to 10	4
( )			

 Parameter that can be modified during operation or when stopped.

# Configuration Mode - Complete menu (FULL)

200 -  
300 -  
400 -  
500 -  
600 -  
700 -

Code	Name/Description	Adjustment range	Factory setting
<b>500 -</b>	<b>Function menu (continued)</b>		
<b>502 -</b>	<b>Stop configuration menu</b>		
<b>502.4</b>	<input type="checkbox"/> <b>DC injection assignment</b>		00
<b>00</b> <b>L1H</b> <b>L2H</b> <b>L3H</b> <b>L4H</b> <b>LUH</b>	<p style="text-align: center;"><b>⚠ WARNING</b></p> <p><b>UNINTENDED MOVEMENT</b></p> <ul style="list-style-type: none"> <li>Do not use DC injection to generate holding torque when the motor is at a standstill.</li> <li>Use a holding brake to keep the motor in the standstill position.</li> </ul> <p><b>Failure to follow these instructions can result in death, serious injury, or equipment damage.</b></p> <p>DC injection is activated when the input switches to 0. If the input returns to state 1 and the run command is still active, the motor will only restart if <b>Type of control 201</b> (page 58) = 2C and <b>2-wire type control 202</b> (page 62) = 00 or 02. If not, a new run command must be sent. This parameter is forced to 00 if <b>Type of stop 502.0</b> is set to 08 (page 85)</p> <ul style="list-style-type: none"> <li><input type="checkbox"/> Not assigned.</li> <li><input type="checkbox"/> L1H: L1 active high</li> <li><input type="checkbox"/> L2H: L2 active high</li> <li><input type="checkbox"/> L3H: L3 active high</li> <li><input type="checkbox"/> L4H: L4 active high</li> <li><input type="checkbox"/> LUH: LIU active high (AI1 used as logic input: AI1 type 204.0 sets to L I U)</li> </ul>		
<b>502.5</b>	<input type="checkbox"/> <b>DC injection level</b>	0.1*In to 1.41*In (1)	0.64*In (in A)
<b>( )</b>	<p style="text-align: center;"><b>NOTICE</b></p> <p><b>OVERHEATING</b></p> <p>Verify that the connected motor is properly rated for the DC injection current to be applied in terms of amount and time.</p> <p><b>Failure to follow these instructions can result in equipment damage.</b></p> <p>Level of DC injection braking current activated via digital input or selected as stop mode. This parameter can be accessed if <b>DC injection assignment 502.4</b> is set to a value different from 00 or if <b>Type of stop 502.0</b> is set to <b>DC injection stop 03</b>. <b>NOTE:</b> this setting is independent from the <b>AUTO DC INJECTION MENU 504</b> - function.</p>		
<b>502.6</b>	<input type="checkbox"/> <b>IDC injection time for DCL</b>	0.1 s to 30 s	0.5 s
<b>( )</b>	<p style="text-align: center;"><b>NOTICE</b></p> <p><b>OVERHEATING</b></p> <p>Verify that the connected motor is properly rated for the DC injection current to be applied in terms of amount and time.</p> <p><b>Failure to follow these instructions can result in equipment damage.</b></p> <p>Maximum current injection time <b>DC injection level 502.5</b>. After this time, the injection current becomes <b>DC injection level 2 502.7</b>. This parameter can be accessed if <b>DC injection assignment 502.4</b> is set to a value different from 00 or if <b>Type of stop 502.0</b> is set to <b>DC injection stop 03</b>. <b>NOTE:</b> this setting is independent from the <b>AUTO DC INJECTION MENU 504</b> - function.</p>		

(1) In = rated drive current

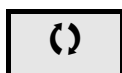

Parameter that can be modified during operation or when stopped.

# Configuration Mode - Complete menu (FULL)

200 -  
300 -  
400 -  
500 -  
600 -  
700 -

Code	Name/Description	Adjustment range	Factory setting
500 -	<b>Function menu</b> (continued)		
502 -	<b>Stop configuration menu</b>		
502.7	<input type="checkbox"/> <b>DC injection level 2</b>	0.1*In to DC injection level 502.5 (1)	0.5*In (in A)
( )	<p style="text-align: center;"><b>NOTICE</b></p> <p><b>OVERHEATING</b> Verify that the connected motor is properly rated for the DC injection current to be applied in terms of amount and time. <b>Failure to follow these instructions can result in equipment damage.</b></p> <p>Injection current activated by digital input or selected as stop mode once period IDC injection time for DCLI 502.6 has elapsed. This parameter can be accessed if DC injection assignment 502.4 is set to a value different from 00 or if Type of stop 502.0 is set to DC injection stop 03. <b>NOTE:</b> this setting is independent from the AUTO DC INJECTION MENU 504 - function.</p>		
502.8	<input type="checkbox"/> <b>Injection standstill braking time</b>	0.1 s to 30 s	0.5 s
( )	<p style="text-align: center;"><b>NOTICE</b></p> <p><b>OVERHEATING</b> Verify that the connected motor is properly rated for the DC injection current to be applied in terms of amount and time. <b>Failure to follow these instructions can result in equipment damage.</b></p> <p>Maximum injection time for DC injection level 2 502.7, selected as stop mode only. This parameter can be accessed if Type of stop 502.0 is set to DC injection stop 03. <b>NOTE:</b> this setting is independent from the AUTO DC INJECTION MENU 504 - function.</p>		

(1) In = rated drive current

( ) Parameter that can be modified during operation or when stopped.

Code	Name/Description	Adjustment range	Factory setting
500 -	<b>Function menu</b> (continued)		
503	<input type="checkbox"/> <b>Reverse direction</b>		00
00 L1H L2H L3H L4H LUH	<p>L1 - L14: choice of the input assigned to the reverse command</p> <ul style="list-style-type: none"> <li><input type="checkbox"/> Function inactive</li> <li><input type="checkbox"/> L1H: L1 active high</li> <li><input type="checkbox"/> L2H: L2 active high</li> <li><input type="checkbox"/> L3H: L3 active high</li> <li><input type="checkbox"/> L4H: L4 active high</li> <li><input type="checkbox"/> LUH: LIU active high</li> </ul>		

# Configuration Mode - Complete menu (FULL)

200 -  
300 -  
400 -  
500 -  
600 -  
700 -

Code	Name/Description	Adjustment range	Factory setting
<b>500 -</b>	<b>Function menu (continued)</b>		
<b>504 -</b>	<b>AUTO DC INJECTION MENU</b>		
<b>504.0</b> ( )	<input type="checkbox"/> <b>Automatic DC injection</b>		01
<b>00</b> <b>01</b> <b>02</b>	<p style="text-align: center;"><b>⚠ ⚠ DANGER</b></p> <p><b>HAZARD OF ELECTRIC SHOCK, EXPLOSION, OR ARC FLASH</b> If the parameter <b>504.0</b> Automatic DC injection is set to <b>02</b>, DC injection is always active, even if the motor does not run. Verify that using this setting does not result in unsafe conditions. <b>Failure to follow these instructions will result in death or serious injury.</b></p> <hr/> <p style="text-align: center;"><b>⚠ WARNING</b></p> <p><b>UNINTENDED MOVEMENT</b></p> <ul style="list-style-type: none"> <li>Do not use DC injection to generate holding torque when the motor is at a standstill.</li> <li>Use a holding brake to keep the motor in the standstill position.</li> </ul> <p><b>Failure to follow these instructions can result in death, serious injury, or equipment damage.</b></p> <p><input type="checkbox"/> No DC injected current <input type="checkbox"/> Time limited DC injection <input type="checkbox"/> Continuous DC injection</p> <p><b>NOTE:</b> <b>504.0</b> is set to <b>00</b> when <b>Motor control type 309</b> (page 69) is set to <b>05</b>.</p>		
<b>504.1</b> ( )	<input type="checkbox"/> <b>Automatic DC injection current</b>	0 to 1.2*In (1)	0.7*In (in A)
	<p style="text-align: center;"><b>NOTICE</b></p> <p><b>OVERHEATING AND DAMAGE TO THE MOTOR</b> Verify that the connected motor is properly rated for the DC injection current to be applied in terms of amount and time in order to avoid overheating and damage to the motor. <b>Failure to follow this instruction can result in equipment damage.</b></p> <p>Visible only if <b>Automatic DC injection 504.0</b> is not set to <b>00</b>. Injection current on stopping and continuous DC injection.</p>		
<b>504.2</b> ( )	<input type="checkbox"/> <b>Automatic DC injection time</b>	0.1 to 30 s	0.5 s
	<p style="text-align: center;"><b>NOTICE</b></p> <p><b>OVERHEATING AND DAMAGE TO THE MOTOR</b> Verify that the connected motor is properly rated for the DC injection current to be applied in terms of amount and time in order to avoid overheating and damage to the motor. <b>Failure to follow this instruction can result in equipment damage.</b></p> <p>Visible only if <b>Automatic DC injection 504.0</b> is not set to <b>00</b>. Injection time on stopping.</p>		

(1) In = rated drive current

 Parameter that can be modified during operation or when stopped.

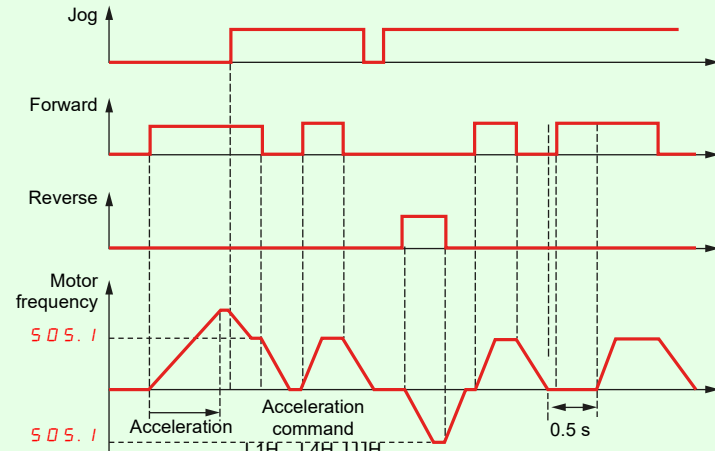
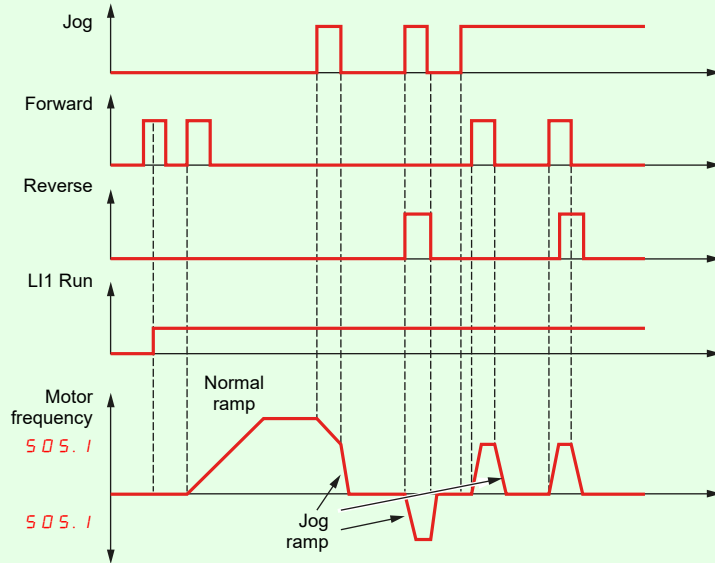
Code	Name/Description	Adjustment range	Factory setting
<b>500 - Function menu (continued)</b>			
<p><b>505.0</b></p> <p><b>00</b></p> <p><b>L1H</b></p> <p><b>L2H</b></p> <p><b>L3H</b></p> <p><b>L4H</b></p> <p><b>L4H</b></p>	<p><input type="checkbox"/> <b>Jog assignment</b></p> <p>This parameter employs a 2 or 3-wire control related logic input, providing step by step control of motor running. Acceleration and deceleration ramps taken into account in the Jog function are 0.1 s.</p> <ul style="list-style-type: none"> <li><input type="checkbox"/> Function inactive</li> <li><input type="checkbox"/> L1H: L1 active high</li> <li><input type="checkbox"/> L2H: LI2 active high</li> <li><input type="checkbox"/> L3H: LI3 active high</li> <li><input type="checkbox"/> L4H: LI4 active high</li> <li><input type="checkbox"/> LUH: LIU active high</li> </ul> <p><b>2 wire type control</b></p>  <p><b>3-wire control</b></p> 	<p>00</p>	<p>00</p>
<p><b>505.1</b></p>	<p><input type="checkbox"/> <b>Jog Frequency</b></p> <p>Reference in jog function</p>	<p>0 to 10 Hz</p>	<p>5 Hz</p>

# Configuration Mode - Complete menu (FULL)

200-  
300-  
400-  
500-  
600-  
700-

Code	Name/Description	Adjustment range	Factory setting
<b>500 -</b>	<b>Function menu (continued)</b>		
<b>506 -</b>	<b>Speed up and down</b>		
<b>506.0</b>	<input type="checkbox"/> <b>Up speed command</b>  00: Function inactive L1H: LI1 active high L2H: LI2 active high L3H: LI3 active high L4H: LI4 active high LUH: LIU active high		00
00 L1H L2H L3H L4H LUH			
<b>506.1</b>	<input type="checkbox"/> <b>Down speed command</b>  00: Function inactive L1H: LI1 active high L2H: LI2 active high L3H: LI3 active high L4H: LI4 active high LUH: LIU active high		00
00 L1H L2H L3H L4H LUH			
	<p>The diagram illustrates the relationship between speed commands and speed profile. It shows a speed profile with multiple ramps. Annotations indicate: 'Variable saved to RAM or ROM' (solid line), 'Variable not saved' (dashed line), and 'Variable saved to RAM' (dotted line). Below the speed profile are timing signals for 'Up speed command', 'Down speed command', 'Clear the function', 'Forward', and 'Main supply'.</p>		
<b>506.2</b>	<input type="checkbox"/> <b>Store</b>  Up speed/down speed command will change the initial speed reference. Eventually it produces an overall "speed increment". This speed increment accumulates over time depending on the actions of Lix and Liy. It is therefore necessary to keep a record of speed incrementation when changing speed reference. Visible only if parameter <b>506.0</b> and <b>506.1</b> are configured.		00
00 01 02	<input type="checkbox"/> Do not save. Variables not saved after the RUN command has disappeared. <input type="checkbox"/> Save to RAM. Variables saved to RAM after STOP command ends and disappear when power off. <input type="checkbox"/> Save to ROM. Variables saved to ROM when power off.		

# Configuration Mode - Complete menu (FULL)

200-  
300-  
400-  
500-  
600-  
700-

Code	Name/Description	Adjustment range	Factory setting
<b>506 -</b>	<b>Speed up and down (continued)</b>		
<b>506.3</b>	<input type="checkbox"/> <b>Clear the function</b>  When the CLEAR command is activated, acceleration and deceleration commands are deactivated. All speed increments are reset when the CLEAR command is activated, regardless of the save method used. Visible only if parameter <b>506.0</b> and <b>506.1</b> are configured.	0 - 100%	00
00 L1H L2H L3H L4H LUH 159	<input type="checkbox"/> [00], Function inactive <input type="checkbox"/> [L1H], LI1 active high <input type="checkbox"/> [L2H], LI2 active high <input type="checkbox"/> [L3H], LI3 active high <input type="checkbox"/> [L4H], LI4 active high <input type="checkbox"/> [LUH], LIU active high <input type="checkbox"/> The function is cleared when [159] acceleration and deceleration commands activate simultaneously.		
<b>506.4</b>	<input type="checkbox"/> <b>Reactivity of +/- speed around ref.</b>  An experience value between 0 to 100% is used to change the rapidity of response for acceleration and deceleration command inputs. Visible only if parameters <b>506.0</b> and <b>506.1</b> are configured.	0 - 100%	0%

## Preset speeds

2, 4, or 8 speeds can be preset, requiring 1, 2 or 3 logic inputs respectively.

### Combination table for preset speed inputs

8 speeds LI (507.2)	4 speeds LI (507.1)	2 speeds LI (507.0)	Speed reference
0	0	0	Preset speed
0	0	1	Preset speed 2
0	1	0	Preset speed 3
0	1	1	Preset speed 4
1	0	0	Preset speed 5
1	0	1	Preset speed 6
1	1	0	Preset speed 7
1	1	1	Preset speed 8

# Configuration Mode - Complete menu (FULL)

200-  
300-  
400-  
500-  
600-  
700-

Code	Name/Description	Adjustment range	Factory setting
<b>500-</b>	<b>Function menu (continued)</b>		
<b>507-</b>	<b>Preset speed menu</b>		
<b>507.0</b> <i>00</i> <i>L1H</i> <i>L2H</i> <i>L3H</i> <i>L4H</i> <i>LUH</i>	<input type="checkbox"/> <b>2 preset speeds</b>  <input type="checkbox"/> Function inactive <input type="checkbox"/> L1H: L1 high activation level <input type="checkbox"/> L2H: L12 active high <input type="checkbox"/> L3H: L13 active high <input type="checkbox"/> L4H: L14 active high <input type="checkbox"/> LUH: active high		00
<b>507.1</b>	<input type="checkbox"/> <b>4 preset speeds</b> As <b>507.0</b>		00
<b>507.2</b>	<input type="checkbox"/> <b>8 preset speeds</b> As <b>507.0</b>		00
<b>507.3</b> ( )	<input type="checkbox"/> <b>Preset speed 2</b> Visible only if 2 preset speeds <b>507.0</b> is not set to <b>00</b> .	0 to 400 Hz	10 Hz
<b>507.4</b> ( )	<input type="checkbox"/> <b>Preset speed 3</b> Visible only if 4 preset speeds <b>507.1</b> is not set to <b>00</b> .	0 to 400 Hz	15 Hz
<b>507.5</b> ( )	<input type="checkbox"/> <b>Preset speed 4</b> Visible only if 2 preset speeds <b>507.0</b> and 4 preset speeds <b>507.1</b> are not set to <b>00</b> .	0 to 400 Hz	20 Hz
<b>507.6</b> ( )	<input type="checkbox"/> <b>Preset speed 5</b> Visible only if 8 preset speeds <b>507.2</b> is not set to <b>00</b> .	0 to 400 Hz	25 Hz
<b>507.7</b> ( )	<input type="checkbox"/> <b>Preset speed 6</b> Visible only if 2 preset speeds <b>507.0</b> and 8 preset speeds <b>507.2</b> are not set to <b>00</b> .	0 to 400 Hz	30 Hz
<b>507.8</b> ( )	<input type="checkbox"/> <b>Preset speed 7</b> Visible only if 4 preset speeds <b>507.1</b> and 8 preset speeds <b>507.2</b> are not set to <b>00</b> .	0 to 400 Hz	35 Hz
<b>507.9</b> ( )	<input type="checkbox"/> <b>Preset speed 8</b> Visible only if 2 preset speeds <b>507.0</b> , 4 preset speeds <b>507.1</b> and 8 preset speeds <b>507.2</b> are not set to <b>00</b> .	0 to 400 Hz	40 Hz
<b>508</b> ( )	<input type="checkbox"/> <b>Skip frequency</b>  This parameter prevents prolonged operation within an adjustable range around <b>508</b> frequency of $\pm 1$ Hz. This function can be used to prevent a critical speed which would cause resonance being reached. Setting the function to 0 renders it inactive.	0 to 400 Hz	0 Hz

( ) Parameter that can be modified during operation or when stopped.

# Configuration Mode - Complete menu (FULL)

200 -  
300 -  
400 -  
**500 -**  
600 -  
700 -

## PID diagram

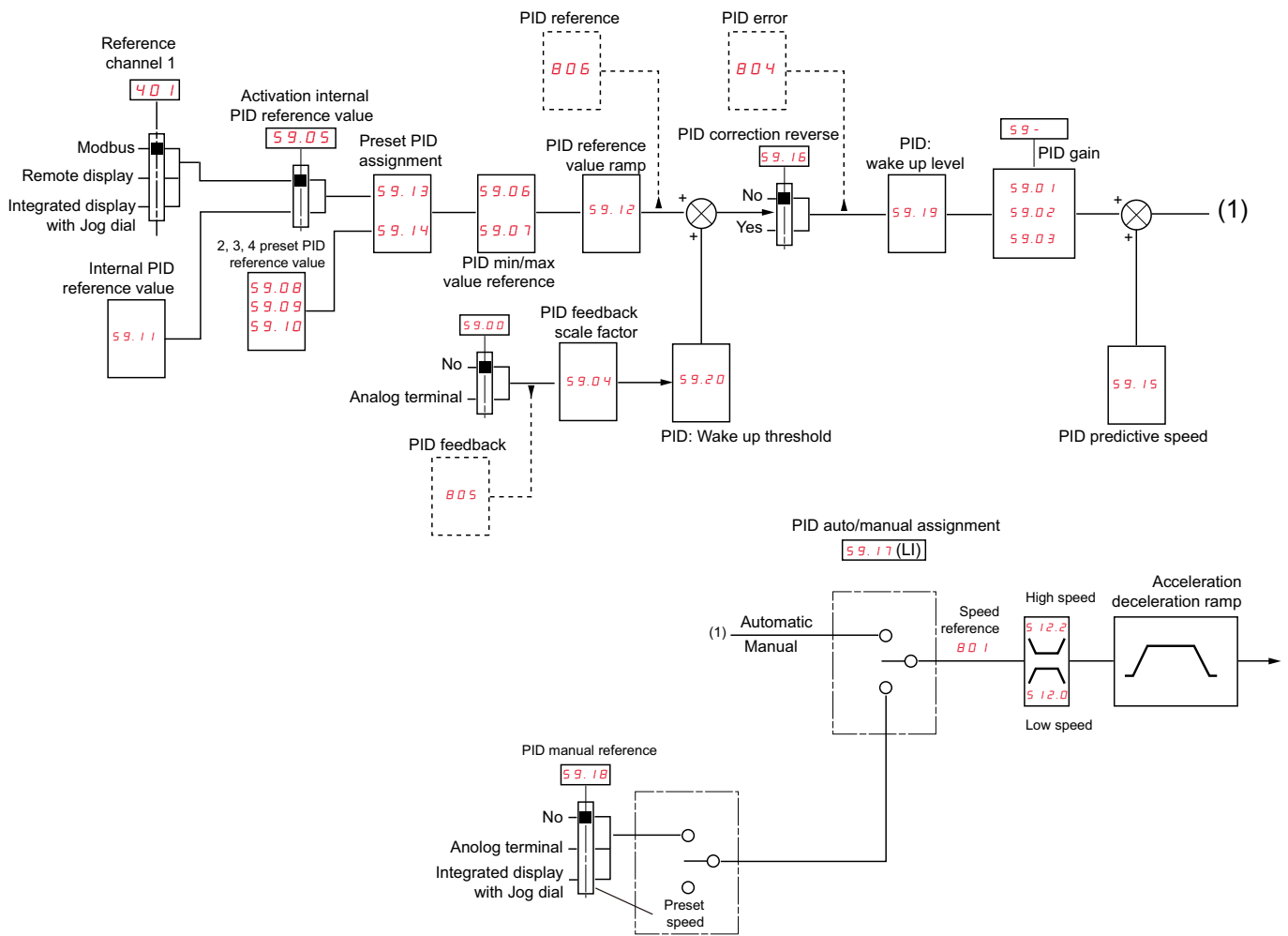

# Configuration Mode - Complete menu (FULL)

200 -  
300 -  
400 -  
500 -  
600 -  
700 -

Code	Name/Description	Adjustment range	Factory setting
<b>500 -</b>	<b>Function menu (continued)</b>		
<b>59 -</b>	<b>PID menu</b>		
<b>59.00</b>  00 01	<input type="checkbox"/> <b>PID feedback assignment</b>  <input type="checkbox"/> Not assigned. <input type="checkbox"/> Analog terminal. Choice not possible if 401 is set to 01.		00
<b>59.01</b> (↻)	<input type="checkbox"/> <b>PID proportional gain</b>  Visible only if [PID feedback assignment <b>59.00</b> is not set to <b>00</b> .	0.01 to 100	1
<b>59.02</b> (↻)	<input type="checkbox"/> <b>PID integral gain</b>  Visible only if [PID feedback assignment <b>59.00</b> is not set to <b>00</b> .	0.01 to 100	1
<b>59.03</b> (↻)	<input type="checkbox"/> <b>PID derivative gain</b>  Visible only if [PID feedback assignment <b>59.00</b> is not set to <b>00</b> .	0.00 to 100.00	0.00
<b>59.04</b> (↻)	<input type="checkbox"/> <b>PID feedback scale factor</b>  This parameter gives the relation between process range and feedback range. Visible only if [PID feedback assignment <b>59.00</b> is not set to <b>00</b> .	0.1 to 100.0	1.0
<b>59.05</b>  00 01	<input type="checkbox"/> <b>Activation internal PID reference value</b>  Visible only if [PID feedback assignment <b>59.00</b> is not set to <b>00</b> .  <input type="checkbox"/> No <input type="checkbox"/> Yes		00
<b>59.06</b>  00 L1H L2H L3H L4H LUH	<input type="checkbox"/> <b>2 preset PID assignment</b>  Visible only if [PID feedback assignment <b>59.00</b> is not set to <b>00</b> .  <input type="checkbox"/> None <input type="checkbox"/> L1H <input type="checkbox"/> L2H <input type="checkbox"/> L3H <input type="checkbox"/> L4H <input type="checkbox"/> LUH		00

 Parameter that can be modified during operation or when stopped.

# Configuration Mode - Complete menu (FULL)

200 -  
300 -  
400 -  
500 -  
600 -  
700 -

Code	Name/Description	Adjustment range	Factory setting
<b>500 -</b>	<b>Function menu (continued)</b>		
<b>59 -</b>	<b>PID menu (continued)</b>		
<b>59.07</b>  00 L1H L2H L3H L4H LUH	<input type="checkbox"/> <b>4 preset PID assignment</b>  Visible only if [PID feedback assignment <b>59.00</b> (page 94) is not set to <b>00</b> . <input type="checkbox"/> None <input type="checkbox"/> L1H: LI1 active high <input type="checkbox"/> L2H: LI2 active high <input type="checkbox"/> L3H: LI3 active high <input type="checkbox"/> L4H: LI4 active high <input type="checkbox"/> LUH Before assigning 4 preset PID assignment <b>59.07</b> , 2 preset PID assignment <b>59.06</b> (page 94) must be assigned.		00
<b>59.08</b> ( )	<input type="checkbox"/> <b>2 preset PID reference value</b>  Visible only if [PID feedback assignment <b>59.00</b> (page 94) and 2 preset PID assignment <b>59.06</b> (page 94) are not set to <b>00</b> .	0 to 100%	25%
<b>59.09</b> ( )	<input type="checkbox"/> <b>3 preset PID reference value</b>  Visible only if [PID feedback assignment <b>59.00</b> (page 94) and 4 preset PID assignment <b>59.07</b> (page 95) are not set to <b>00</b> .	0 to 100%	50%
<b>59.10</b> ( )	<input type="checkbox"/> <b>4 preset PID reference value</b>  Visible only if [PID feedback assignment <b>59.00</b> (page 94), 2 preset PID assignment <b>59.06</b> and 4 preset PID assignment <b>59.07</b> (page 95) are not set to <b>00</b> .	0 to 100%	75%
<b>59.11</b> ( )	<input type="checkbox"/> <b>Internal PID reference value</b>  Visible only if [PID feedback assignment <b>59.00</b> (page 94) is not set to <b>00</b> and Activation internal PID reference value <b>59.05</b> (page 94) is set to <b>01</b> or Reference channel 1 <b>401</b> (page 81) is set to <b>163</b> .	0 to 100%	0%
<b>59.12</b> ( )	<input type="checkbox"/> <b>PID reference value ramp</b>  Visible only if [PID feedback assignment <b>59.00</b> (page 94) is not set to <b>00</b> .	0 to 99.9 s	0 s
<b>59.13</b> ( )	<input type="checkbox"/> <b>PID min value reference</b>  Visible only if [PID feedback assignment <b>59.00</b> (page 94) is not set to <b>00</b> .	0 to 100%	0%
<b>59.14</b> ( )	<input type="checkbox"/> <b>PID max value reference</b>  Visible only if [PID feedback assignment <b>59.00</b> (page 94) is not set to <b>00</b> .	0 to 100%	100%
<b>59.15</b>	<input type="checkbox"/> <b>PID predictive speed</b>  This parameter allows direct attainment of a set speed reference. Visible only if [PID feedback assignment <b>59.00</b> (page 94) is not set to <b>00</b> .	0.1 to 400 Hz	nO

( ) Parameter that can be modified during operation or when stopped.

# Configuration Mode - Complete menu (FULL)

200 -  
300 -  
400 -  
500 -  
600 -  
700 -

Code	Name/Description	Adjustment range	Factory setting
<b>500 -</b>	<b>Function menu (continued)</b>		
<b>59 -</b>	<b>PID menu (continued)</b>		
<b>501.4</b> 	<input type="checkbox"/> <b>Acceleration 2</b>  This parameter only can be activated when the system is starting. Second acceleration ramp time, adjustable from 0.1 to 999.9 s. The time required to accelerate from 0 to <b>Rated motor frequency 306</b> (page 69). Make sure that this value is compatible with the inertia being driven.  Visible only if <b>PID feedback assignment 59.00</b> (page 94) and <b>PID predictive speed 59.15</b> (page 95) are not set to <b>00</b> .	0.0 to 999.9 s	5.0 s
<b>59.16</b>  <b>00</b> <b>01</b> <b>02</b> <b>03</b>	<input type="checkbox"/> <b>PID correction reverse</b>  This parameter will reverse the internal error value of PID system. <input type="checkbox"/> No, no negative speed <input type="checkbox"/> Yes, no negative speed <input type="checkbox"/> No, allow negative speed <input type="checkbox"/> Yes, allow negative speed  Visible only if: <b>PID feedback assignment 59.00</b> (page 94) is not set to <b>00</b> Negative speed possible only if <b>Low speed 512.0</b> is set to <b>00</b> <b>Reverse inhibition 404</b> is set to <b>00</b>		00
<b>59.17</b>  <b>00</b> <b>L1H</b> <b>L2H</b> <b>L3H</b> <b>L4H</b> <b>LUH</b>	<input type="checkbox"/> <b>PID auto/manual assignment</b>  At state 0 of input, PID is active. At state 1 of input, manual run is active. <input type="checkbox"/> No <input type="checkbox"/> L1H: LI1 active high <input type="checkbox"/> L2H: LI2 active high <input type="checkbox"/> L3H: LI3 active high <input type="checkbox"/> L4H: LI4 active high <input type="checkbox"/> LUH: LIU active high  Visible only if <b>PID feedback assignment 59.00</b> (page 94) is not set to <b>00</b> .		00
<b>59.18</b>  <b>00</b> <b>01</b> <b>183</b>	<input type="checkbox"/> <b>PID manual reference</b>  This parameter can disable the PID and enable the standard manual reference. <input type="checkbox"/> No <input type="checkbox"/> Analog terminal <input type="checkbox"/> Integrated display with Jog dial  Visible only if <b>PID feedback assignment 59.00</b> (page 94) and <b>PID auto/manual assignment 59.17</b> (page 96) are not set to <b>00</b> .		00

 Parameter that can be modified during operation or when stopped.

# Configuration Mode - Complete menu (FULL)

Code	Name/Description	Adjustment range	Factory setting
<b>500 -</b>	<b>Function menu (continued)</b>		
<b>59 -</b>	<b>PID menu (continued)</b>		
<b>512.1</b> ( )	<input type="checkbox"/> <b>Low speed operating time</b> A motor stop is requested automatically following a defined period of operation at <b>Low speed 512.0</b> (page 109). The motor restarts if the frequency reference is greater than <b>Low speed 512.0</b> and if a run command is still present. <b>NOTE:</b> <b>00</b> value corresponds to an unlimited period.  Visible only if <b>PID feedback assignment 59.00</b> (page 94) is not set to <b>00</b> .	0.1 to 999.9 s	00
<b>59.19</b>	<input type="checkbox"/> <b>PID: wake up level</b> If PID functions and <b>Low speed operating time 512.1</b> are set at the same time, the PID regulator may try to set a speed lower than <b>Low speed 512.0</b> . This will result in unwanted operations consisting of starting, running at <b>Low speed 512.0</b> , stopping and so on. Parameter <b>PID: wake up level 59.19</b> can be used to set a minimum PID error threshold to restart after a prolonged stop below <b>Low speed 512.0</b> .  Visible only if <b>PID feedback assignment 59.00</b> (page 94) and <b>Low speed operating time 512.1</b> (page 109) are not set to <b>00</b> .	0 to 100%	0%
<b>59.20</b> ( )	<input type="checkbox"/> <b>PID: Wake up threshold</b> If <b>PID correction reverse 59.16</b> (page 96) is set to nO, this parameter can be used to set the PID feedback threshold. Following a stop caused by exceeding the maximum time at low speed <b>512.1</b> , the PID regulator is reactivated (wake-up) when this threshold is exceeded. If <b>59.16</b> is set to <b>01</b> , the PID regulator is reactivated (wake-up) when this threshold is exceeded, following a stop caused by exceeding the maximum time at low speed <b>512.1</b> .  Visible only if <b>PID feedback assignment 59.00</b> (page 94) and <b>Low speed operating time 512.1</b> (page 109) is not set to <b>00</b> .	0 to 100%	0%
<b>59.21</b>	<input type="checkbox"/> <b>Sleep offset threshold</b> 0 ~ 512.2 (*0)	0 to <b>512.2</b>	0 Hz
<b>59.22</b>	<input type="checkbox"/> <b>PID feedback supervision threshold</b> 0 - 100% (*0)	0 - 100%	0 (No)
<b>59.23</b> ( )	<input type="checkbox"/> <b>PID supervision function time delay</b> 0 - 600s (*0)	0 - 600s	0 s
<b>59.24</b> ( )	<input type="checkbox"/> <b>Maximum frequency detection Hysteresis</b>	0 to <b>512.2</b>	0 Hz
<b>59.25</b>	<input type="checkbox"/> <b>PID feedback supervision</b> <input type="checkbox"/> Fault and freewheel stop <input type="checkbox"/> Fall back speed		01
<b>01</b> <b>04</b>			
<b>59.26</b>	<input type="checkbox"/> <b>Fall back speed</b> 0~ high speed frequency (*0).	0 to <b>512.2</b>	0 Hz

( ) Parameter that can be modified during operation or when stopped.

# Configuration Mode - Complete menu (FULL)

200 -  
300 -  
400 -  
500 -  
600 -  
700 -

Code	Name/Description	Adjustment range	Factory setting
<b>5 10 -</b>	<b>PUMP SUB-MENU</b>		
<b>207</b>	<input type="checkbox"/> <b>Process overload time delay</b> <p>This function can be used to stop the motor in the event of a process overload. This is not a motor or drive thermal overload. If the motor current exceeds the <b>Process overload threshold 208</b>, a <b>Process overload time delay 207</b> is activated. Once this time delay <b>207</b> has elapsed, if the current is still greater than the overload threshold <b>208</b> -10%, the drive will stop running and display Process overload. Overload detection is only active when the system is in steady state (Actual speed reference reached). A value of 0 will disable application overload detection.</p> <p>Estimated motor current                      Drive stop on detection of <b>F 0 12</b> fault.</p>	0-100 s	0 s
<b>208</b> ( )	<input type="checkbox"/> <b>Process overload threshold</b> <p>Visible only if <b>Process overload time delay 207</b> above is not <b>0</b>. This parameter is used to detect an "application overload". <b>208</b> can be adjusted between 70 and 150% of the rated drive current. This is not the same as a motor or drive thermal overload.</p>	70% - 150% of <b>305</b> parameter value 70% - 150%	90% of <b>305</b> parameter value
<b>209</b> ( )	<input type="checkbox"/> <b>Process overload fault duration</b> <p>If <b>602.0=0 1</b>, the drive will automatically restart after this time delay following the overload fault <b>F 0 12</b>. Minimum time permitted between an overload being detected and any automatic restart. In order for an automatic restart to be possible, the maximum restart time <b>602. 1</b> (page <a href="#">111</a>) must exceed that of this parameter by at least one minute.</p> <p>Visible only if the "Overload time delay <b>207</b>" above is not set to 0.</p>	0-6 min.	0 min.
<b>210</b>	<input type="checkbox"/> <b>Process underload time delay</b> <p><b>210</b> can be adjust between 0 to 100 s                      If the motor current undershoots the underload threshold <b>211</b> for longer than the adjustable time delay <b>210</b>, the drive will stop running and display <b>F 0 29</b> (Underload fault), see page <a href="#">125</a>.</p> <p>Estimated motor current                      When <b>F 0 29</b> fault is detected</p>	0-100 s	0 s
<b>211</b> ( )	<input type="checkbox"/> <b>Process Underload threshold</b> <p>Visible only if <b>Process underload time delay 210</b> is not set to <b>0</b>. This parameter is used to detect an application underload condition on the motor. <b>Process underload threshold 211</b> can be adjusted between 20 and 100% of the rated drive current.</p>	20% to 100% of 305 parameter	60%

( ) Parameter that can be modified during operation or when stopped.

# Configuration Mode - Complete menu (FULL)

Code	Name/Description	Adjustment range	Factory setting
<b>2 12</b> 	<input type="checkbox"/> <b>Process underload fault duration</b>  If <b>6 0 2.0=0 1</b> , the drive will automatically restart after this time delay following the Process underload fault <b>F 0 2 9</b> . Minimum time permitted between an underload being detected and any automatic restart. In order for an automatic restart to be possible, the maximum restart time <b>6 0 2. 1</b> (page <a href="#">111</a> ) must exceed that of this parameter by at least one minute.  Visible only if the "Process underload time delay <b>2 1 0</b> " above is not set to 0.	0-6 min.	0 min.
<b>5 10.0</b> <b>0 0</b> <b>0 1</b>	<input type="checkbox"/> <b>Selecting operating mode</b>  <input type="checkbox"/> No: single frequency conversion mode <input type="checkbox"/> Yes: single frequency conversion combined with auxiliary pump mode  If <b>5 10.0 = [ 0 1 ]</b> , digital output <b>L 6</b> will automatically assign value pump switching.		
<b>5 10.1</b>	<input type="checkbox"/> <b>Starting frequency of the auxiliary pump</b>  The auxiliary pump will start if this frequency is exceeded and after the pump start time delay (value of <b>5 10.2</b> ).	0- <b>3 0 8</b> parameter value	<b>5 12.2</b> parameter value
<b>5 10.2</b>	<input type="checkbox"/> <b>Time delay before starting auxiliary pump</b>  This time avoids the effects of transient pressure fluctuations and so avoids vibrations generated during pump starting and stopping.	0-999.9s	2 s
<b>5 10.3</b>	<input type="checkbox"/> <b>Auxiliary pump ramp reaching</b>  This time avoids the effects of transient pressure fluctuations and so avoids vibrations generated during pump starting and stopping.	0-999.9s	2 s
<b>5 10.4</b>	<input type="checkbox"/> <b>Auxiliary pump stop frequency</b>  The auxiliary pump will stop below this frequency after the auxiliary pump stop delay (value of <b>5 10.5</b> ).	0- <b>3 0 8</b> parameter value	0Hz
<b>5 10.5</b>	<input type="checkbox"/> <b>Auxiliary pump stop time delay</b>  This time avoids the effects of transient pressure fluctuations and so avoids vibrations generated during pump starting and stopping.	0-999.9s	2 s
<b>5 10.6</b>	<input type="checkbox"/> <b>Auxiliary pump stop ramp</b>  This time avoids the effects of transient pressure fluctuations and so avoids vibrations generated during pump starting and stopping.	0-999.9s	2 s
<b>5 10.7</b>	<input type="checkbox"/> <b>Zero flow detection period</b>  Function inactive if value is 0.	0-20 min.	0 min.
<b>5 10.8</b>	<input type="checkbox"/> <b>Zero flow detection activation threshold</b>  Below this threshold function activated if <b>5 10.7</b> value >0 and the auxiliary pump is stopped.	0-400Hz	0Hz
<b>5 10.9</b>	<input type="checkbox"/> <b>Zero flow detection offset</b>  Below this threshold function activated if <b>5 10.7</b> value >0 and the auxiliary pump is stopped.	0-400Hz	0Hz

## Architecture of the pumping installation

Single variable mode - 1 single variable speed pump

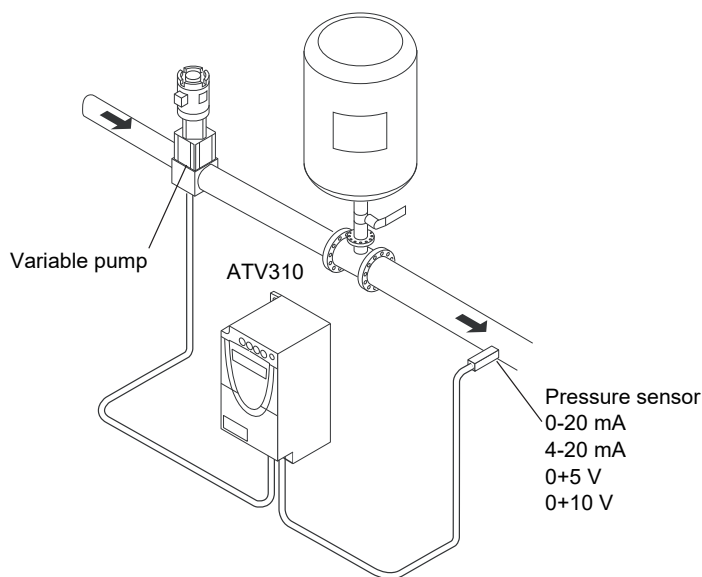

Enter the values given on the motor rating plate in the Motor control menu 300-

### First level adjustment parameters

- 5 0 1.0 Acceleration: 0.7 s
- 5 0 1.1 Deceleration: 0.7 s
- 5 1 2.0 Low speed: 30 Hz
- 5 1 2.2 High speed: 60 Hz

### Analog input menu Alt

- 2 0 4.0 Scale of analog input AI1: 0-20 mA

### Motor control menu drC

- 3 1 1 Slip compensation: 0%
- 3 1 3 Frequency loop gain: 70%
- 3 1 0 IR compensation: 0%

### Application functions menu FUn

- 2 0 2 2-wire type control: LEL

PI sub-menu

- 5 9.0 0 Assignment of the PI function feedback: AI1
- 5 9.0 1 PI regulator proportional gain: 5.00
- 5 9.0 2 PI regulator integral gain: 8.00
- 5 9.1 1 Internal PI regulator reference: 39%
- 5 9.1 9 Restart error threshold: 40%
- 5 9.2 5 Supervision of the PI regulator function: LFF
- 5 9.2 2 PI feedback supervision threshold: 17%
- 5 9.2 3 PI feedback supervision function time delay: 1 s
- 5 9.2 6 Fallback speed: 50 Hz

Pump sub-menu PMP

- 5 1 0. 7 Zero flow detection: 1 min
- 5 1 0. 8 Zero flow detection activation threshold: 50 Hz
- 5 1 0. 9 Zero flow detection offset: 5 Hz
- 5 1 2. 1 Sleep threshold operating time: 3 s
- 5 9. 1 5 Quick start threshold: 25 Hz
- 5 9. 2 1 Sleep threshold offset: 10 Hz

Automatic DC injection sub-menu AdC

- 5 0 4.0 Automatic DC injection assignment: nO

Automatic restart function Atr

- 6 0 2.0 Automatic restart: YES

### Fault menu 600-

- 2 0 8 Process Overload threshold: 11%
- 2 0 9 Process overload fault duration: 1
- 5 9. 2 4 Frequency hysteresis reached: 2 Hz

# Configuration Mode - Complete menu (FULL)

Single variable with auxiliary pump mode - 1 variable speed pump (variable pump) and one fixed speed pump (auxiliary pump)

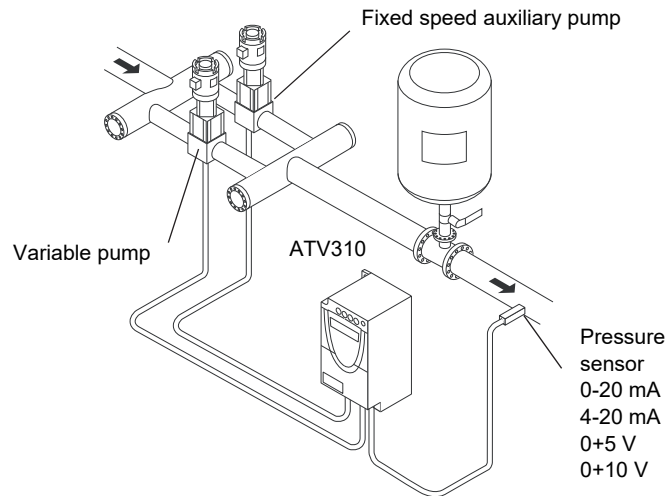

The auxiliary pump is controlled by the ATV310 via logic output LO.

Enter the values given on the motor rating plate in the Motor control menu 300-

## First level adjustment parameters

**5 0 1.0** Acceleration: 0.1 s

**5 0 1.1** Deceleration: 0.1 s

**5 12.0** Low speed: 35 Hz

## Analog input menu 204-

**2 0 4.0** Scale of analog input AI1: 0-20 mA

## Motor control menu 300-

**3 1 1** Slip compensation: 0%

**3 1 3** Frequency loop gain: 70%

**3 1 0** IR compensation: 0%

## Application functions menu FUn

**2 0 2** 2-wire type control: 00

### PI sub-menu

**5 9.0 0** Assignment of the PI function feedback: 01

**5 9.0 1** PI regulator proportional gain: 5.00

**5 9.0 2** PI regulator integral gain: 8.00

**5 9.1 1** Internal PI regulator reference: 51%

**5 9.1 9** Restart error threshold: 42%

### Pump sub-menu PMP

**5 10.0** Selecting the operating mode: 01 (Yes)

**5 10.1** Starting frequency of the auxiliary pump: 49 Hz

**5 10.2** Time delay before starting the auxiliary pump: 1 s

**5 10.3** Ramp for reaching the nominal speed of the auxiliary pump: 1 s

**5 10.4** Stopping frequency of the auxiliary pump: 39.6 Hz

**5 10.5** Time delay before the auxiliary pump stop command: 1 s

**5 10.6** Ramp for stopping the auxiliary pump: 1 s

**5 10.7** Zero flow detection: 1 min

**5 10.8** Zero flow detection activation threshold: 42 Hz

**5 10.9** Zero flow detection offset: 2 Hz

**5 12.1** Sleep threshold operating time: 5 s

**5 9.2 1** Sleep threshold offset: 3 Hz

**2 0 6.1** Assignment as logic/analog output PMP

### Automatic DC injection sub-menu 504-

**5 0 4.0** Automatic DC injection assignment: 00

### Automatic restart function 602-

**6 0 2.0** Automatic restart: 01 (active)

### Fault menu 600-

**2 1 0** Process underload function time delay 5 s

**2 1 1** Process underload threshold: 59%

**2 1 2** Time delay before automatic restart for the underload fault: 1

# Configuration Mode - Complete menu (FULL)

## Connection diagram

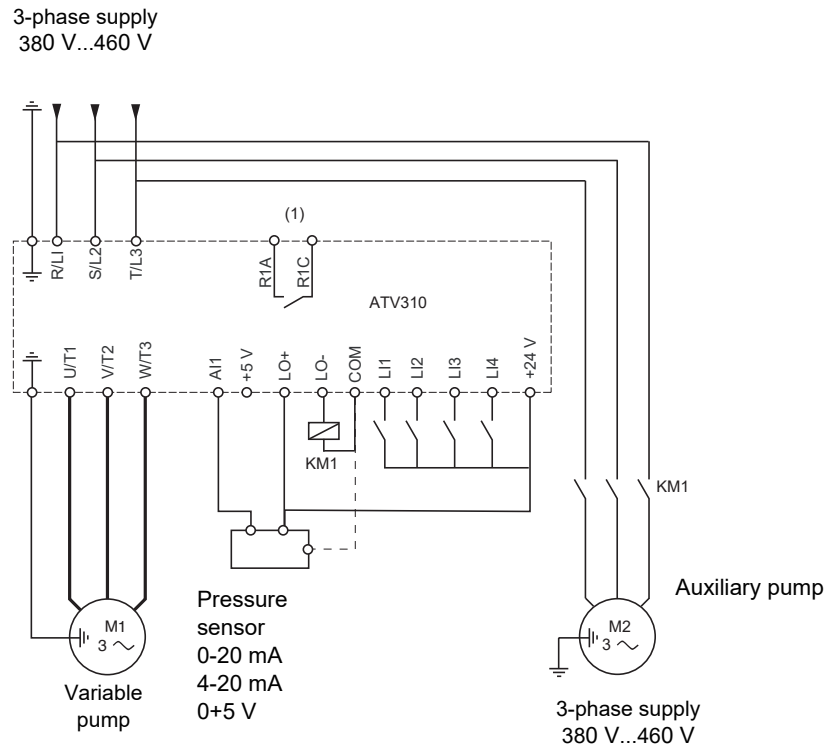

(1) Fault relay contacts, for remote indication of the drive status.

**NOTE:** Fit interference suppressors to all inductive circuits near the drive or connected to the same circuit (relays, contactors, solenoid valves, etc.).

**NOTE:** This wiring example is in source using internal supply.

# Configuration Mode - Complete menu (FULL)

## PI feedback supervision (59.25)

Used to define the operating mode in the event of detection of a PI feedback lower than the limit set.

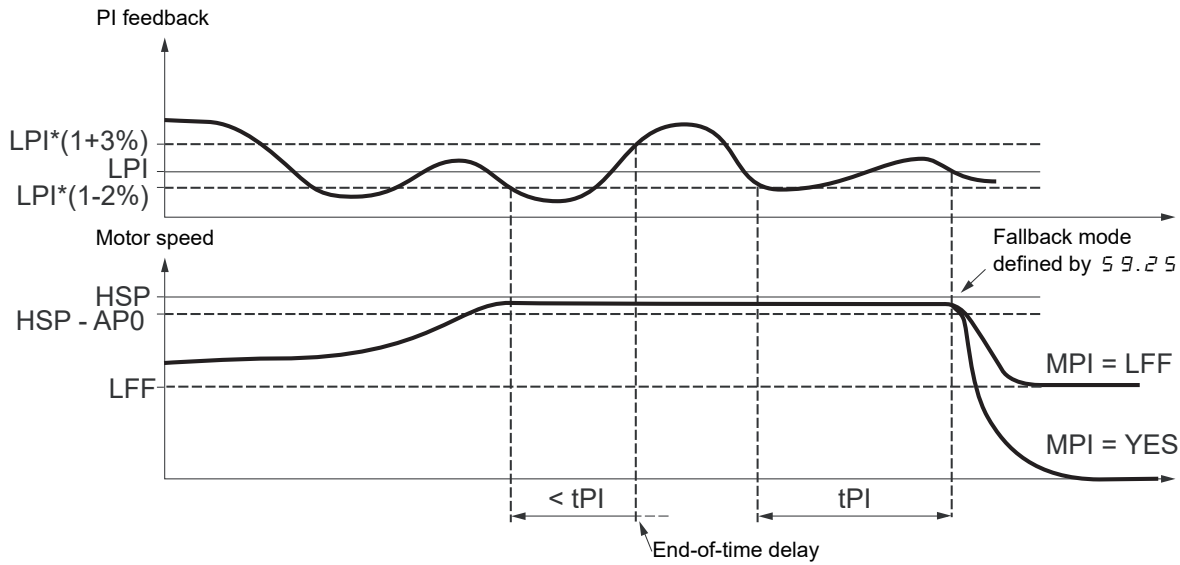

Once the variable pump is running at maximum speed (higher than  $512.2 - 59.24$ ) and at the same time the PI feedback is lower than the supervision threshold  $59.22 \cdot (1-2\%)$ , a time delay  $t_{PI}$  is launched. If at the end of this time delay the value of the PI feedback is still lower than the supervision threshold  $59.22 \cdot (1+3\%)$ , the drive switches to fallback mode as defined by parameter  $59.25$ .

-  $59.25 = 01$ :

The drive will perform a freewheel stop.

-  $59.25 = 04$ :

The drive will run at a fixed frequency  $59.26$  and will display fault code  $--12$ .

In both cases the drive reverts to PI regulation mode as soon as the PI feedback is higher than the supervision threshold  $59.22 \cdot (1+3\%)$ . In single variable with auxiliary pump mode ( $510.0 = 01$ ), the PI feedback supervision function is only active when both pumps are operating.

# Configuration Mode - Complete menu (FULL)

## Pump submenu PMP

The principal objective is to control a complete pumping installation using a single drive by providing constant pressure whatever the flow rate.

The system is operated using an auxiliary fixed speed pump, and one variable speed pump, which is unable to provide the full flow range required on its own. A PI regulator is used for drive control. The pressure sensor provides system feedback.

The variable speed pump is called a variable pump.

The fixed speed pump is called an auxiliary pump.

### Selecting the operating mode

The ATV310 offers 2 operating modes:

- Single variable mode: 1 single variable speed pump (variable pump).
- Single variable with auxiliary pump mode: 1 variable speed pump (variable pump) and one fixed speed pump (auxiliary pump).

### Control of the auxiliary pump

The PI regulator output (frequency reference of the variable pump) is used to control starting or stopping of the auxiliary pump with hysteresis, as shown in the figure below:

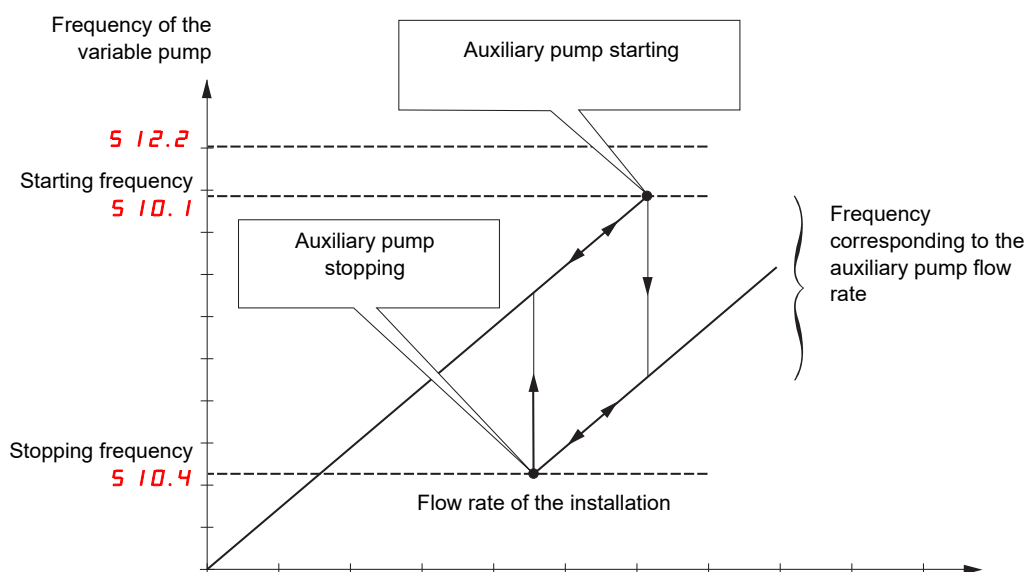

When the frequency exceeds the starting threshold (**S 10.1**), a time delay (**S 10.2**) is launched to avoid the effects of transient flow fluctuations. If after this time delay, the frequency remains higher than the starting threshold, the auxiliary pump is started. When the start command is sent, the variable pump will go from its current speed reference to the auxiliary pump stopping frequency (**S 10.4**) following a ramp (**S 10.3**) that equals the time taken for the auxiliary pump to reach its nominal speed. Parameter rOn is used to minimize the booster effect on starting the auxiliary pump.

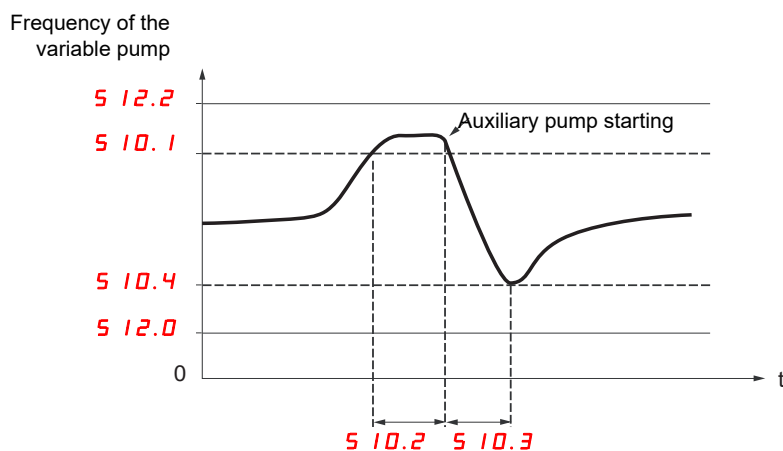

# Configuration Mode - Complete menu (FULL)

When the frequency is lower than the stopping threshold (**S 10.4**), a time delay is launched (**S 10.5**) to avoid the effects of transient flow fluctuations. If after this time delay, the frequency remains lower than the stopping threshold, the auxiliary pump is stopped. When the stop command is sent, the variable pump will go from its current speed reference to the auxiliary pump starting frequency (**S 10.1**) following a ramp (**S 10.6**) that equals the auxiliary pump stopping time. Parameter **S 10.6** is used to minimize the booster effect on stopping the auxiliary pump.

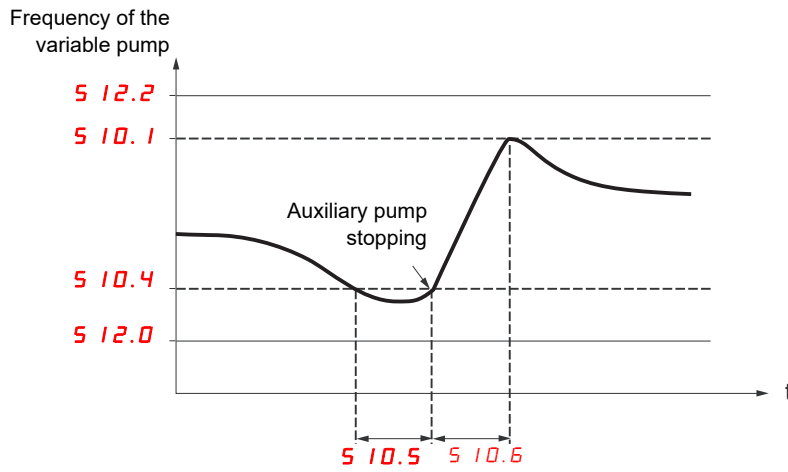

## "Sleep" function/"Wake-up" function

This function is used to stop the variable pump when there is zero flow (auxiliary pump stopped). In this case, if the frequency of the variable pump is lower than the "sleep" threshold ( $S 12.0 + S 9.2 1$ ), a time delay ( $S 12.1$ ) is launched. If, after this time delay, the frequency remains lower than threshold  $S 12.0 + S 9.2 1$ , the variable pump then stops. The installation is in "sleep" mode.

To switch to "wake-up" mode, the pressure feedback must drop to below the "wake-up" threshold  $S 9.2 0$ . The variable pump is then started.

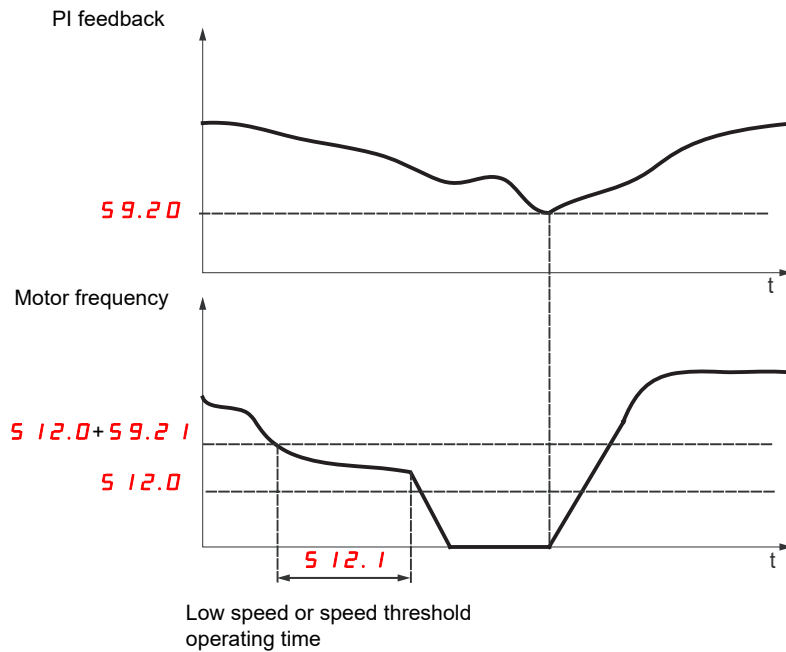

## Quick start function

The quick start function can be used to overcome problems linked to high  $S 9.0 1$  and  $S 9.0 2$  gains (instability on starting). The drive accelerates until it reaches the quick start threshold  $S 9.1 5$  following a ramp  $S 10.4$ . Once the threshold has been reached, the PI regulator is activated.

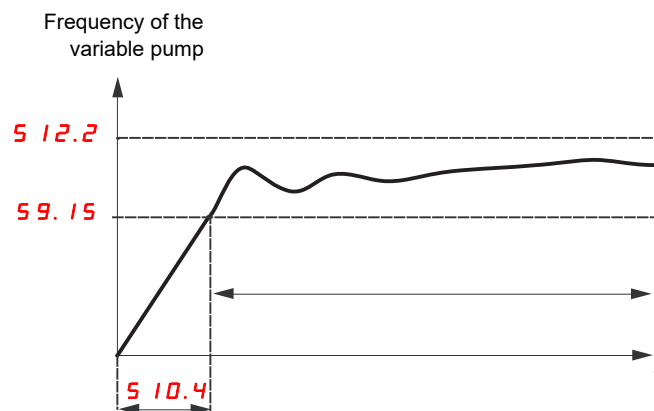

# Configuration Mode - Complete menu (FULL)

## Zero flow detection

This function is only active when the auxiliary pump is stopped and the motor frequency is below threshold  $S 10.8$ .

This function is used in applications where zero flow cannot be detected by the sleep function alone. It forces the drive frequency reference to  $S 12.0 + S 10.9$  periodically (at each time interval  $S 10.7$ ) in order to test for zero flow.

- If the request is still present, the PI error increases, causing the drive to restart.

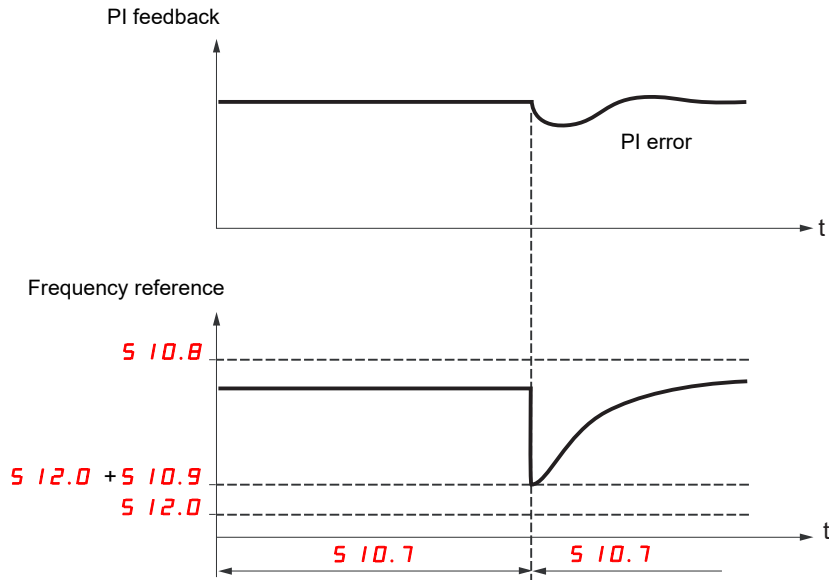

- If the request is no longer present (zero flow), the PI error will not increase.

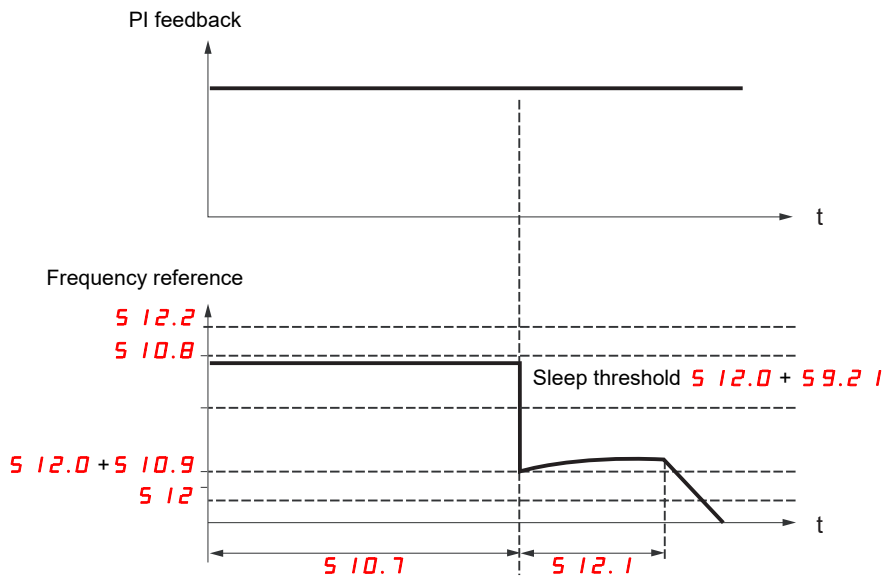

- Set the sleep function so that the drive switches to sleep mode when zero flow is detected ( $S 10.9 \text{ T } S 9.2 I$ ).

# Configuration Mode - Complete menu (FULL)

200-  
300-  
400-  
500-  
600-  
700-

Code	Name/Description	Adjustment range	Factory setting
<b>500-</b>	<b>Function menu (continued)</b>		
<b>511-</b>	<b>CURRENT LIMITATION MENU</b>		
<b>511.0</b>	<input type="checkbox"/> <b>2nd current limitation commutation</b>  Assignment <input type="checkbox"/> Function inactive <input type="checkbox"/> L1H: LI1 active high <input type="checkbox"/> L2H: LI2 active high <input type="checkbox"/> L3H: LI3 active high <input type="checkbox"/> L4H: LI4 active high <input type="checkbox"/> LUH: LIU active high <input type="checkbox"/> L1L: LI1 active low <input type="checkbox"/> L2L: LI2 active low <input type="checkbox"/> L3L: LI3 active low <input type="checkbox"/> L4L: LI4 active low <input type="checkbox"/> LUL: LIU active low  If the assigned input is at 0, the first current limitation is active. If the assigned input is at 1, the second current limitation is active. See LI assignment information (page 56).		00
<b>511.1</b> (↻)	<input type="checkbox"/> <b>Current limitation</b>  First current limitation.	0.25 to 1.5 In (1)	Determined by drive rating and dual rating
<b>NOTICE</b>			
<b>OVERHEATING AND DAMAGE TO THE MOTOR</b> Depending on the settings of this parameter, the error response to detected errors is disabled or the transition to the operating state Fault is suppressed if an error is detected. <ul style="list-style-type: none"> <li>• Verify that the settings of this parameter do not result in equipment damage.</li> <li>• Implement alternative monitoring functions for disabled monitoring functions.</li> </ul> <b>Failure to follow these instructions can result in equipment damage.</b>			
<b>511.2</b> (↻)	<input type="checkbox"/> <b>Current limitation 2</b>  Second current limitation. This function allows reduction of the drive current limit.  Visible only if <b>2nd current limitation commutation 511.0</b> (page 108) is not set to <b>00</b> .	0.25 to 1.5 In (1)	Determined by drive rating and dual rating
<b>NOTICE</b>			
<b>OVERHEATING AND DAMAGE TO THE MOTOR</b> Depending on the settings of this parameter, the error response to detected errors is disabled or the transition to the operating state Fault is suppressed if an error is detected. <ul style="list-style-type: none"> <li>• Verify that the settings of this parameter do not result in equipment damage.</li> <li>• Implement alternative monitoring functions for disabled monitoring functions.</li> </ul> <b>Failure to follow these instructions can result in equipment damage.</b>			

(1) In = rated drive current

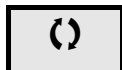

Parameter that can be modified during operation or when stopped.

# Configuration Mode - Complete menu (FULL)

200 -  
300 -  
400 -  
500 -  
600 -  
700 -

Code	Name/Description	Adjustment range	Factory setting
<b>500 -</b>	<b>Function menu</b> (continued)		
<b>512 -</b>	<b>Speed limit menu</b>		
<b>512.0</b> ⌚	<input type="checkbox"/> <b>Low speed</b>  Motor frequency at minimum reference.	0 Hz to 512.2 parameter value	0 Hz
<b>512.1</b> ⌚	<input type="checkbox"/> <b>Low speed operating time</b>  Following operation at <b>Low speed 512.0</b> for a defined period, a motor stop is requested automatically. The motor restarts if the reference value is greater than <b>Low speed 512.0</b> and if a run command is still present. <b>NOTE:</b> <b>00</b> corresponds to an unlimited period.	0.1 to 999.9 s	00

# Configuration Mode - Complete menu (FULL)

## High speed configuration

The logic inputs enable selection of the desired high speed.

Desired High speed	Setting		Desired High speed	Setting	
	Parameter	State		Parameter	State
512.2	512.3	00	512.6	512.3	00
	512.4	00		512.4	assigned
512.5	512.3	assigned	512.7	512.3	assigned
	512.4	00		512.4	assigned

Code	Name/Description	Adjustment range	Factory setting
500-	<b>Function menu (continued)</b>		
512-	<b>Speed limit menu</b>		
512.2 ( )	<input type="checkbox"/> <b>High speed</b>  Motor frequency at maximum reference can be set in the range <b>Low speed 512.0</b> to <b>Maximum frequency 308</b> (page 69). If <b>Maximum frequency 308</b> falls below the value defined for <b>512.2</b> , <b>512.2</b> automatically drops to the new value of <b>Maximum frequency 308</b> .	512.0 to 308 parameter value	50 or 60 Hz determined by 301 parameter value, maximum 308 parameter value
512.3 00 L1H L2H L3H L4H LUH	<input type="checkbox"/> <b>2 High speed assignment</b>  <input type="checkbox"/> None <input type="checkbox"/> L1H: LI1 active high <input type="checkbox"/> L2H: LI2 active high <input type="checkbox"/> L3H: LI3 active high <input type="checkbox"/> L4H: LI4 active high <input type="checkbox"/> LUH: LIU active high		00
512.4 00 L1H L2H L3H L4H LUH	<input type="checkbox"/> <b>4 High speed assignment</b>  <input type="checkbox"/> None <input type="checkbox"/> L1H: LI1 active high <input type="checkbox"/> L2H: LI2 active high <input type="checkbox"/> L3H: LI3 active high <input type="checkbox"/> L4H: LI4 active high <input type="checkbox"/> LUH: LIU active high		00
512.5 ( )	<input type="checkbox"/> <b>High speed 2</b>  Visible only if <b>2 High speed assignment 512.3</b> is not set to <b>00</b> .	512.0 to 308	As 512.2 parameter value
512.6 ( )	<input type="checkbox"/> <b>High speed 3</b>  Visible only if <b>4 High speed assignment 512.4</b> is not set to <b>00</b> .	512.0 to 308	As 512.2 parameter value
512.7 ( )	<input type="checkbox"/> <b>High speed 4</b>  Visible only if <b>2 High speed assignment 512.3</b> and <b>4 High speed assignment 512.4</b> are not set to <b>00</b> .	512.0 to 308	As with 512.2 parameter value
513 00 01	<input type="checkbox"/> <b>Cooling fan control</b>  <input type="checkbox"/> Fan runs while drive is running <input type="checkbox"/> Temperature control mode, fan starting and stopping controlled on basis of IGBT temperature		01

( ) Parameter that can be modified during operation or when stopped.

Code	Name/Description	Adjustment range	Factory setting
<b>600 -</b>	<b>FAULT DETECTION MANAGEMENT MENU</b>		
<b>601</b>	<input type="checkbox"/> <b>Detected fault reset assignment</b>  Manual fault reset. <input type="checkbox"/> Function inactive <input type="checkbox"/> L1H: LI1 active high <input type="checkbox"/> L2H: LI2 active high <input type="checkbox"/> L3H: LI3 active high <input type="checkbox"/> L4H: LI4 active high <input type="checkbox"/> LUH: LIU active high Faults are reset when the assigned input or bit changes to 1, if the cause of the fault has disappeared. The STOP/RESET button on the graphic display terminal performs the same function. See also Diagnostics and Troubleshooting (page <a href="#">124</a> ).		00
<b>00</b> <b>L1H</b> <b>L2H</b> <b>L3H</b> <b>L4H</b> <b>LUH</b>			
<b>602 -</b>	<b>Automatic restart menu</b>		
<b>602.0</b>	<input type="checkbox"/> <b>Automatic restart</b>  This function can be used to automatically perform individual or multiple Fault Resets. If the cause of the error that has triggered the transition to the operating state Fault disappears within while this function is active, the drive resumes normal operation. While the Fault Reset attempts are performed automatically, the output signal "Operating state Fault" is not available. If the attempts to perform the Fault Reset are not successful, the drive remains in the operating state Fault and the output signal "Operating state Fault" becomes active.		00
<b>00</b> <b>01</b>			
	<b>⚠ WARNING</b> <b>UNANTICIPATED EQUIPMENT OPERATION</b> <ul style="list-style-type: none"> <li>Verify that activating this function does not result in unsafe conditions.</li> <li>Verify that the fact that the output signal "Operating state Fault" is not available while this function is active does not result in unsafe conditions.</li> </ul> <b>Failure to follow these instructions can result in death, serious injury or equipment damage.</b>		
<b>602.1</b>	<input type="checkbox"/> <b>Max. automatic restart</b>  <input type="checkbox"/> 5 min. <input type="checkbox"/> 10 min. <input type="checkbox"/> 30 min. <input type="checkbox"/> 1 hr <input type="checkbox"/> 2 hr <input type="checkbox"/> 3 hr <input type="checkbox"/> Infinite Visible only if <b>Automatic restart 602.0</b> is not set to <b>00</b> . This parameter can be used to limit the number of consecutive restarts on a recurrent fault.		5 min.
<b>00</b> <b>01</b> <b>02</b> <b>03</b> <b>04</b> <b>05</b> <b>06</b>			

# Configuration Mode - Complete menu (FULL)

200 -  
300 -  
400 -  
500 -  
600 -  
700 -

Code	Name/Description	Adjustment range	Factory setting
600 -	<b>FAULT DETECTION MANAGEMENT MENU (continued)</b>		
603	<input type="checkbox"/> <b>Catch on the fly</b> This function is used to enable a smooth restart if the run command is maintained after the following events: <ul style="list-style-type: none"> <li>• Loss of line supply or disconnection</li> <li>• Reset of current fault or automatic restart</li> <li>• Freewheel stop</li> </ul> The speed given by the drive resumes from the estimated speed of the motor at the time of the restart, then follows the ramp to the reference speed. This function requires 2-wire level control.		00
00	<input type="checkbox"/> Function inactive		
01	<input type="checkbox"/> Function active		

## Motor thermal protection

### Function:

Thermal protection by calculating the  $I^2t$ .

- Naturally-cooled motors:  
The tripping curves depend on the motor frequency.
- Force-cooled motors:  
Only the 50 Hz tripping curve need be considered, regardless of the motor frequency.

Trip time in seconds

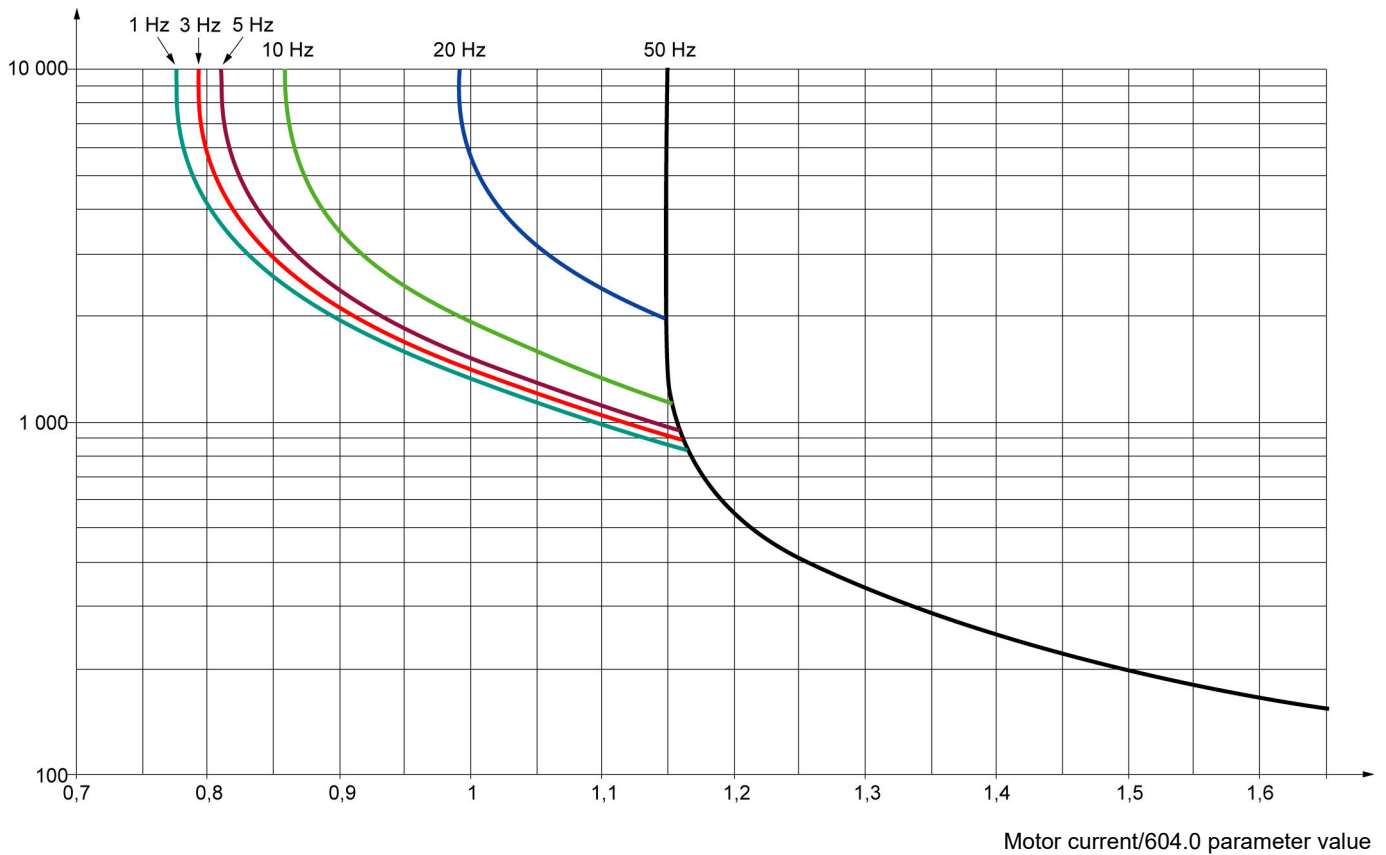

# Configuration Mode - Complete menu (FULL)

200 -  
300 -  
400 -  
500 -  
600 -  
700 -

Code	Name/Description	Adjustment range	Factory setting
<b>600 -</b>	<b>FAULT DETECTION MANAGEMENT MENU (continued)</b>		
<b>604 -</b>	<b>Motor Thermal Protection menu</b>		
<b>604.0</b> <b>(C)</b>	<input type="checkbox"/> <b>Motor thermal current</b>  Current used for motor thermal detection. Set I <sub>TH</sub> to the nominal current on the motor rating plate.	0.2 to 1.5 I <sub>n</sub> (1)	Determined by drive rating
<b>604.1</b> <b>01</b> <b>02</b>	<input type="checkbox"/> <b>Motor protection type</b>  <input type="checkbox"/> Self-ventilated <input type="checkbox"/> Motor-ventilated		01
<b>604.2</b> <b>00</b> <b>01</b> <b>08</b>	<input type="checkbox"/> <b>Overload fault management</b>  Type of stop in the event of a motor thermal fault. <input type="checkbox"/> Fault ignored <input type="checkbox"/> Freewheel stop <input type="checkbox"/> DC injection Overload fault management Setting <b>604.2</b> to <b>00</b> inhibits the <b>Motor overload fault F013</b> (page 126).		01
<b>NOTICE</b>			
<b>OVERHEATING AND DAMAGE TO THE MOTOR</b> If this parameter is set to 00, the error response to detected errors is disabled and the transition to the operating state Fault is suppressed. <ul style="list-style-type: none"> <li>• Verify that the settings of this parameter do not result in equipment damage.</li> <li>• Implement alternative monitoring functions for disabled monitoring functions.</li> </ul> <b>Failure to follow these instructions can result in equipment damage.</b>			
<b>604.3</b> <b>00</b> <b>01</b>	<input type="checkbox"/> <b>Motor thermal state memo</b>  <input type="checkbox"/> Motor thermal state not stored at power off <input type="checkbox"/> Motor thermal state is stored at power off		00
<b>600 -</b>	<b>FAULT DETECTION MANAGEMENT MENU (continued)</b>		
<b>605</b> <b>00</b> <b>01</b>	<input type="checkbox"/> <b>Output Phase loss</b>  <b>HAZARD OF ELECTRIC SHOCK, EXPLOSION, OR ARC FLASH</b> If output phase monitoring is disabled, phase loss and, by implication, accidental disconnection of cables, are not detected. Verify that the setting of this parameter does not result in unsafe conditions. <b>Failure to follow these instructions will result in death or serious injury.</b>  <input type="checkbox"/> Function inactive <input type="checkbox"/> Tripping on <b>F014</b> (1 phase loss) or <b>F015</b> (3 phase loss) fault with freewheel stop.  <b>NOTE:</b> The parameter is set to <b>00</b> when <b>Motor control type 309</b> (page 69) is set to <b>05</b> (Synchronous motor control). For other Motor control type the default value of the parameter is <b>01</b> .		01

(1) I<sub>n</sub> = rated drive current

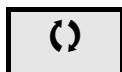

Parameter that can be modified during operation or when stopped.

# Configuration Mode - Complete menu (FULL)

200 -  
300 -  
400 -  
500 -  
600 -  
700 -

Code	Name/Description	Adjustment range	Factory setting
<b>600 -</b>	<b>FAULT DETECTION MANAGEMENT MENU (continued)</b>		
<b>606</b>  00 01  08	<input type="checkbox"/> <b>Input Phase loss</b>  This parameter is only accessible in this menu on 3-phases drives.  <input type="checkbox"/> Fault ignored <input type="checkbox"/> Fault with freewheel stop If one phase disappears, the drive switches to fault mode, but if 2 or 3 phases disappear, the drive continues to operate until it trips on an undervoltage fault.  <input type="checkbox"/> DC Injection		01
<b>607 -</b>	<b>Undervoltage menu</b>		
<b>607.0</b>  00 01	<input type="checkbox"/> <b>Undervoltage detected fault management</b>  Behaviour of the drive in the event of an undervoltage  <input type="checkbox"/> Detected fault and R1 relay set to 0 <input type="checkbox"/> Detected fault and R1 relay set to 1		00
<b>607.1</b>  00 01  02	<input type="checkbox"/> <b>Undervoltage prevention</b>  Behaviour in the event of the undervoltage fault prevention level being reached  <input type="checkbox"/> No action (freewheel) <input type="checkbox"/> Maintain DC Bus, this stop mode uses the inertia to maintain the DC bus voltage as long as possible. <input type="checkbox"/> Stop following an adjustable ramp <b>Undervoltage ramp deceleration time 607.2</b> .		00
<b>607.2</b>  ⌚	<input type="checkbox"/> <b>Undervoltage ramp deceleration time</b>  Undervoltage prevention <b>607.1 = 02</b> gives this ramp time.	0.0 to 10.0 s	1.0 s
<b>607.4</b>	<input type="checkbox"/> <b>Undervoltage level</b>  170 to 248V: detected undervoltage error level setting in Volts.		248V
<b>607.5</b>	<input type="checkbox"/> <b>Prevention level</b>  248 to 318V: undervoltage prevention level setting in Volts.		318V
<b>600 -</b>	<b>FAULT DETECTION MANAGEMENT MENU (continued)</b>		
<b>608</b>  00 01	<input type="checkbox"/> <b>IGBT Test</b>  <input type="checkbox"/> No test <input type="checkbox"/> The IGBTs are tested on power up and every time a run command is sent. These tests cause a slight delay (a few ms). In the event of a fault, the drive will lock. The following faults can be detected: - Drive output short-circuit (terminals U-V-W): <b>F018, F019, F021</b> display - IGBT faulty: <b>F020</b> display, where x indicates the number of the IGBT concerned IGBT short-circuited: x2F, where x indicates the number of the IGBT concerned		00
<b>609</b>  00 01 08	<input type="checkbox"/> <b>4-20mA loss Behaviour</b>  <input type="checkbox"/> Fault ignored. This configuration is only possible if <b>A11 current scaling parameter of 0% 204.1</b> (page 63) is not greater than 3 mA or <b>A11 type 204.0 = 0 A</b> .  <input type="checkbox"/> Freewheel stop <input type="checkbox"/> DC injection		00

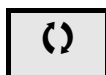

Parameter that can be modified during operation or when stopped.

# Configuration Mode - Complete menu (FULL)

200 -  
300 -  
400 -  
500 -  
600 -  
700 -

Code	Name/Description	Adjustment range	Factory setting
<b>600 -</b>	<b>FAULT DETECTION MANAGEMENT MENU (continued)</b>		
<b>610</b>	<p><input type="checkbox"/> <b>Detected fault inhibition assignment</b></p> <p>In rare cases, the monitoring functions of the drive may be unwanted because they impede the purpose of the application. A typical example is a smoke extractor fan operating as a part of a fire protection system. If a fire occurs, the smoke extractor fan should operate as long as possible, even if, for example, the permissible ambient temperature of the drive is exceeded. In such applications, damage to or destruction of the device may be acceptable as collateral damage, for example, to keep other damage from occurring whose hazard potential is assessed to be more severe.</p> <p>A parameter is provided to disable certain monitoring functions in such applications so that automatic error detection and automatic error responses of the device are no longer active. You must implement alternative monitoring functions for disabled monitoring functions that allow operators and/or master control systems to adequately respond to conditions which correspond to detected errors. For example, if overtemperature monitoring of the drive is disabled, the drive of a smoke extractor fan may itself cause a fire if errors go undetected. An overtemperature condition can be, for example, signaled in a control room without the drive being stopped immediately and automatically by its internal monitoring functions.</p> <div style="background-color: black; color: white; text-align: center; padding: 5px;"><b>⚠ DANGER</b></div> <div style="border: 1px solid black; padding: 5px;"> <p><b>MONITORING FUNCTIONS DISABLED, NO ERROR DETECTION</b></p> <ul style="list-style-type: none"> <li>• Only use this parameter after a thorough risk assessment in compliance with all regulations and standards that apply to the device and to the application.</li> <li>• Implement alternative monitoring functions for disabled monitoring functions that do not trigger automatic error responses of the drive, but allow for adequate, equivalent responses by other means in compliance with all applicable regulations and standards as well as the risk assessment.</li> <li>• Commission and test the system with the monitoring functions enabled.</li> <li>• During commissioning, verify that the drive and the system operate as intended by performing tests and simulations in a controlled environment under controlled conditions.</li> </ul> <p><b>Failure to follow these instructions will result in death or serious injury.</b></p> </div> <p>To assign fault inhibit, press and hold down the ENT key for 2 s.</p> <ul style="list-style-type: none"> <li><input type="checkbox"/> Function inactive</li> <li><input type="checkbox"/> L1H: LI1 active high</li> <li><input type="checkbox"/> L2H: LI2 active high</li> <li><input type="checkbox"/> L3H: LI3 active high</li> <li><input type="checkbox"/> L4H: LI4 active high</li> <li><input type="checkbox"/> LUH: LIU active high</li> </ul> <p>Following detected faults can be inhibited: <b>F008, F025, F028, F011, F013, F014, F015, F016, F022, F024, F027, and F030.</b></p>		00
<p>00</p> <p>L1H</p> <p>L2H</p> <p>L3H</p> <p>L4H</p> <p>LUH</p> <p> 2 s</p>			



To change the assignment of this parameter, press the ENT key for 2 s.

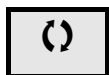

Parameter that can be modified during operation or when stopped.

200 -  
300 -  
400 -  
500 -  
600 -  
700 -

Code	Name/Description	Adjustment range	Factory setting
<b>600 - FAULT DETECTION MANAGEMENT MENU (continued)</b>			
<p><b>611</b></p> <p>00 01 08</p>	<p><input type="checkbox"/> <b>Modbus detected fault management</b></p> <p>Behaviour of the drive in the event of a communication fault with integrated Modbus.</p> <ul style="list-style-type: none"> <li><input type="checkbox"/> Fault ignored</li> <li><input type="checkbox"/> Freewheel stop</li> <li><input type="checkbox"/> DC injection</li> </ul> <div style="border: 1px solid black; padding: 5px; text-align: center;"> <p><b>⚠ WARNING</b></p> <p><b>LOSS OF CONTROL</b></p> <p>If this parameter is set to 00, Modbus communication monitoring is disabled.</p> <ul style="list-style-type: none"> <li>• Only use this setting after a thorough risk assessment in compliance with all regulations and standards that apply to the device and to the application.</li> <li>• Only use this setting for tests during commissioning.</li> <li>• Verify that communication monitoring has been re-enabled before completing the commissioning procedure and performing the final commissioning test.</li> </ul> <p><b>Failure to follow these instructions can result in death, serious injury, or equipment damage.</b></p> </div>	01	
<p><b>612</b></p> <p>00 01</p>	<p><input type="checkbox"/> <b>Degraded line supply operation</b></p> <p>Lowers the tripping threshold of the F030 fault to operate on a line supply down to 50% of nominal line voltage. In this case, a line choke must be used and the performance of the drive controller cannot be guaranteed.</p> <ul style="list-style-type: none"> <li><input type="checkbox"/> No</li> <li><input type="checkbox"/> Yes</li> </ul> <div style="border: 1px solid black; padding: 5px; text-align: center;"> <p><b>NOTICE</b></p> <p><b>RISK OF DAMAGE TO THE DRIVE</b></p> <p>A line choke must be used when the parameter 612 is set to 01.</p> <p><b>Failure to follow these instructions can result in equipment damage.</b></p> </div>	00	
<p><b>613</b></p> <p>00 07</p>	<p><input type="checkbox"/> <b>Reset power run</b></p> <p>This function will initialize the settings in the Monitor (800 -) section, menu 900 - (page 51).</p> <ul style="list-style-type: none"> <li><input type="checkbox"/> No</li> <li><input type="checkbox"/> Reset fan time display</li> </ul>	00	
<p><b>614</b></p> <p>( )</p> <p>00 01</p> <p> 2 s</p>	<p><input type="checkbox"/> <b>Reset all previous detected faults via Run key of HMI</b></p> <p>If this function is active and the RUN key on the equipment panel is pressed for at least 2 s, some detected faults (1) can be reset.</p> <p>This function is only effective for 2-wire or 3-wire control.</p> <p>If <b>Type of control 201</b> (page 58) = 00 and <b>2 wire type control 202</b> (page 62) = 00 and the RUN command is still valid, the drive will run the motor after the fault is reset.</p> <p>To change the assignment of this parameter, press the ENT key for 2 s.</p> <p>(1) These errors include: F001, F002, F006, F008, F010, F014, F015, F017, F018, F019, F020, F021, F025, F027 and F028.</p> <ul style="list-style-type: none"> <li><input type="checkbox"/> Inactive</li> <li><input type="checkbox"/> Active</li> </ul> <div style="border: 1px solid black; padding: 5px; text-align: center;"> <p><b>⚠ WARNING</b></p> <p><b>UNANTICIPATED EQUIPMENT OPERATION</b></p> <p>If parameter 614 is set to 1, pressing the RUN key for 2 s with clear and some detected errors (1).</p> <ul style="list-style-type: none"> <li>• Verify that activating this function does not result in unsafe conditions.</li> <li>• Only use this parameter after a thorough risk assessment in compliance with all regulations and standards that apply to the device and to the application.</li> </ul> <p><b>Failure to follow these instructions can result in death, serious injury, or equipment damage.</b></p> </div>	00	

# Configuration Mode - Complete menu (FULL)

200 -  
300 -  
400 -  
500 -  
600 -  
700 -

Code	Name/Description	Adjustment range	Factory setting
<b>700 -</b>	<b>Communication menu</b>		
	<b>NOTE:</b> For following parameters, the modifications will be taken into account only at the next control power on.		
<b>701</b>	<input type="checkbox"/> <b>Modbus address</b> Modbus address is adjustable in the range <b>0FF</b> to <b>247</b> . When <b>0FF</b> , communication is not active.	OFF to 247	OFF
<b>702</b> <b>24</b> <b>28</b> <b>32</b> <b>36</b>	<input type="checkbox"/> <b>Modbus baud rate</b> <input type="checkbox"/> 4.8 kbps <input type="checkbox"/> 9.6 kbps <input type="checkbox"/> 19.2 kbps <input type="checkbox"/> 38.4 kbps		19.2
<b>703</b> <b>02</b> <b>03</b> <b>04</b> <b>05</b>	<input type="checkbox"/> <b>Modbus format</b> <input type="checkbox"/> 8o1 <input type="checkbox"/> 8E1 <input type="checkbox"/> 8N1 <input type="checkbox"/> 8N2		8E1
<b>704</b>	<input type="checkbox"/> <b>Modbus time out</b> The drive detects a Modbus fault if the drive does not receive a Modbus request within a predefined time period (time out).	0.1 to 30 s	10 s
<b>705 -</b>	<b>Input scanner menu</b> (values are expressed in hexadecimal)		
<b>705.0</b>	<input type="checkbox"/> <b>Com scanner read address parameter 1</b> Address of the 1st input word.		0C81
<b>705.1</b>	<input type="checkbox"/> <b>Com scanner read address parameter 2</b> Address of the 2nd input word.		219C
<b>705.2</b>	<input type="checkbox"/> <b>Com scanner read address parameter 3</b> Address of the 3rd input word.		0000
<b>705.3</b>	<input type="checkbox"/> <b>Com scanner read address parameter 4</b> Address of the 4th input word.		0000
<b>705.4</b>	<input type="checkbox"/> <b>Com scanner read address parameter 5</b> Address of the 5th input word.		0000
<b>705.5</b>	<input type="checkbox"/> <b>Com scanner read address parameter 6</b> Address of the 6th input word.		0000
<b>705.6</b>	<input type="checkbox"/> <b>Com scanner read address parameter 7</b> Address of the 7th input word.		0000
<b>705.7</b>	<input type="checkbox"/> <b>Com scanner read address parameter 8</b> Address of the 8th input word.		0000

# Configuration Mode - Complete menu (FULL)

200 -  
300 -  
400 -  
500 -  
600 -  
700 -

Code	Name/Description	Adjustment range	Factory setting
700 -	<b>Communication menu</b> (continued) <b>NOTE:</b> For following parameters, the modifications will be taken into account only at the next control power on.		
706 -	<b>Output scanner menu</b> (values are expressed in hexadecimal)		
706.0	<input type="checkbox"/> <b>Com scanner write address parameter 1</b> Address of the 1st output word.		2135
706.1	<input type="checkbox"/> <b>Com scanner write address parameter 2</b> Address of the 2nd output word.		219A
706.2	<input type="checkbox"/> <b>Com scanner write address parameter 3</b> Address of the 3rd output word.		0000
706.3	<input type="checkbox"/> <b>Com scanner write address parameter 4</b> Address of the 4th output word.		0000
706.4	<input type="checkbox"/> <b>Com scanner write address parameter 5</b> Address of the 5th output word.		0000
706.5	<input type="checkbox"/> <b>Com scanner write address parameter 6</b> Address of the 6th output word.		0000
706.6	<input type="checkbox"/> <b>Com scanner write address parameter 7</b> Address of the 7th output word.		0000
706.7	<input type="checkbox"/> <b>Com scanner write address parameter 8</b> Address of the 8th output word.		0000

# Configuration Mode - Complete menu (FULL)

200 -  
300 -  
400 -  
500 -  
600 -  
700 -

Code	Name/Description	Adjustment range	Factory setting
<b>700 -</b>	<b>Communication menu</b> (continued)		
<b>707 -</b>	<b>Input scanner access menu</b> (values are expressed in hexadecimal)		
707.0	<input type="checkbox"/> <b>Com scanner read address value 1</b> Value of the 1st input word.		ETA value
707.1	<input type="checkbox"/> <b>Com scanner read address value 2</b> Value of the 2nd input word.		RFRD value
707.2	<input type="checkbox"/> <b>Com scanner read address value 3</b> Value of the 3rd input word.		8000
707.3	<input type="checkbox"/> <b>Com scanner read address value 4</b> Value of the 4th input word.		8000
707.4	<input type="checkbox"/> <b>Com scanner read address value 5</b> Value of the 5th input word.		8000
707.5	<input type="checkbox"/> <b>Com scanner read address value 6</b> Value of the 6th input word.		8000
707.6	<input type="checkbox"/> <b>Com scanner read address value 7</b> Value of the 7th input word.		8000
707.7	<input type="checkbox"/> <b>Com scanner read address value 8</b> Value of the 8th input word.		8000

# Configuration Mode - Complete menu (FULL)

200 -  
300 -  
400 -  
500 -  
600 -  
700 -

Code	Name/Description	Adjustment range	Factory setting
<b>700 -</b>	<b>Communication menu</b> (continued)		
<b>708 -</b>	<b>Output scanner access menu</b> (values are expressed in hexadecimal)		
<b>708.0</b> ( )	<input type="checkbox"/> <b>Com scanner write address value 1</b> Value of the 1st output word.		CMD value
<b>708.1</b> ( )	<input type="checkbox"/> <b>Com scanner write address value 2</b> Value of the 2nd output word.		LFRD value
<b>708.2</b> ( )	<input type="checkbox"/> <b>Com scanner write address value 3</b> Value of the 3rd output word.		8000
<b>708.3</b> ( )	<input type="checkbox"/> <b>Com scanner write address value 4</b> Value of the 4th output word.		8000
<b>708.4</b> ( )	<input type="checkbox"/> <b>Com scanner write address value 5</b> Value of the 5th output word.		8000
<b>708.5</b> ( )	<input type="checkbox"/> <b>Com scanner write address value 6</b> Value of the 6th output word.		8000
<b>708.6</b> ( )	<input type="checkbox"/> <b>Com scanner write address value 7</b> Value of the 7th output word.		8000
<b>708.7</b> ( )	<input type="checkbox"/> <b>Com scanner write address value 8</b> Value of the 8th output word.		8000

 Parameter that can be modified during operation or when stopped.

# Maintenance

## Servicing



### HAZARD OF ELECTRIC SHOCK, EXPLOSION OR ARC FLASH

Read and understand the instructions in "Before your begin" chapter before performing any procedure in this chapter.

**Failure to follow these instructions will result in death or serious injury.**

The ATV310 does not require any preventive maintenance. However, it is advisable to perform the following checks regularly:

- Check environment and tightness of connections
- Remove any dust from the drive
- Ensure proper fan operation

Physical damage to covers

## Services

### NOTICE

#### RISK OF DAMAGE TO DRIVE

Perform the following activities.

**Failure to follow these instructions can result in equipment damage.**

Environment	Related parts	Actions	Periodicity
Product impact	Enclosure - Control panel (LED display)	Check drive display part	Once per month
Corrosion	Terminals - connectors - screws	Check and clean	
Dust	Terminals - fans - vents		
Temperature	Product setting	Check and optimize	
Cooling	Fan	Check fan operation	As required
		Replace fan	
Vibration	Terminal connections	Check connection torque	Once per month

## Prolonged storage

For products that have been stored for more than 2 years, voltage should be gradually increased in product capacitors.

### NOTICE

#### RISK OF DERATED PERFORMANCE DUE TO CAPACITOR AGING

The product capacitor performances after a long time storage above 2 years can be degraded. In that case, before using the product, apply the following procedure:

- Use a variable AC voltage supply, connected between L1 and L2 (even for ATV●●●●N4 catalog numbers).
- Increase AC supply voltage to have:
  - 80% of rated voltage for 30 min
  - 100% of rated voltage for 30 min

**Failure to follow these instructions can result in equipment damage.**

# Maintenance

## Display menu

Use the status of the drive and its current values shown on the display menu as an aid for finding the causes of detected faults.

## Assistance with maintenance, detected fault display

If a problem arises during setup or operation, ensure that the recommendations relating to the environment, mounting and connections have been observed.

The first fault detected is stored and displayed, flashing, on the screen. The drive locks and the status relay R1 contact opens.

## Clearing the detected fault

Disconnect the drive power supply in the event of a non-resettable fault.

Wait for the display to go off completely.

Find the cause of the detected fault and correct it.

Restore power to the drive.

The detected fault will no longer be present if its cause has been corrected.

In the event of a non resettable detected fault:

- Remove/cut the power to the drive.
- WAIT 15 MINUTES to allow the DC bus capacitors to discharge, then follow the "Bus Voltage Measurement Procedure" (page 5) to verify that the DC voltage is less than 42 V. The drive LED is not an accurate indicator of the absence of DC bus voltage.
- Find and correct the detected fault.
- Restore power to the drive to confirm the detected fault has been rectified.
- **Certain detected faults can be programmed for automatic restart after the cause has disappeared.**

These detected faults can also be reset by cycling power to the drive or by means of a logic input or control bit.

## Spares and repairs:

Serviceable product. Refer to spares replacement catalogue.

## Fan replacement

Fan spares can be ordered for the ATV310. Contact the Schneider Electric Customer Care Center for details.

① Remove screw of fan support and pull out the fan support

② Uncoupled the connected parts and remove the fan

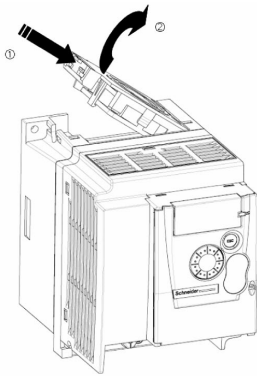

ATV310HU15N4●,  
ATV310HU22N4●

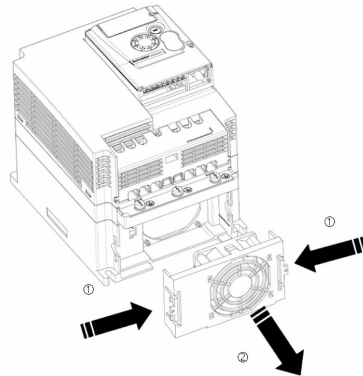

ATV310HU30N4●, ATV310HU40N4●,  
ATV310HU55N4●, ATV310HD15N4●,  
ATV310HD18N4●

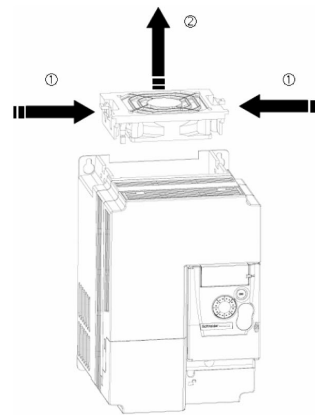

ATV310HU75N4●,  
ATV310HD11N4●

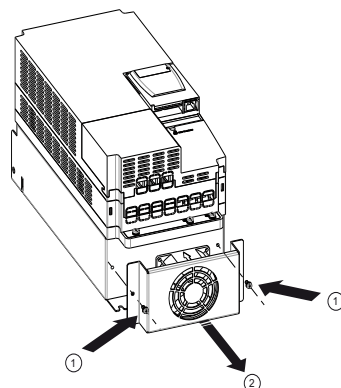

ATV310HD22N4●F

① Grasp the protruding part of fan bayonet mount

② Uncouple the connected parts and remove the fan

## Drive does not start, no error code displayed

- If the display does not light up, check the power supply to the drive (ground and input phase connections, see page 29).
- The assignment of the "Fast stop" or "Freewheel" functions will prevent the drive starting if the corresponding logic inputs are not powered up. The ATV310 then displays **502.1** in freewheel stop mode and **--01** in fast stop mode. **--00** is displayed at freewheel stop end. This is normal, since these functions are active at zero so drive can safely stop in case of wire break. Assignment of LI to be checked in the **CONF/FULL/500-/502-** menu.
- Make sure that the run command input(s) is activated in accordance with the selected control mode (parameters in **CONF/FULL/200-** menu **Type of control 201** (page 58) and **2-wire type control 202** (page 62).
- If the reference channel or command channel is assigned to Modbus, the drive displays "**502.1**" freewheel stop when the power supply is connected and remains in stop mode until the communication bus sends a command.
- "RUN" key is inactive in factory setting. Adjust parameters **Reference channel 1 401** (page 81) and **Command channel 1 407** (page 82) to control the drive locally (**CONF/FULL/400-** menu). See "How to control the drive locally" (page 45).

## Fault detection codes which cannot be cleared automatically

The cause of the detected fault must be removed before resetting by cycling power to the drive.

**F025** and **F028** faults can also be reset remotely by means of a logic input (in **CONF/FULL/600-** menu, parameter **Detected fault reset assignment 601** (page 111).

**F007**, **F025** and **F028** faults can be inhibited and cleared remotely by means of a logic input (parameter **Detected fault inhibition assignment 610** (page 116).

Code	Name	Possible causes	Remedy
----	Problem with application firmware	<ul style="list-style-type: none"> <li>• Invalid application firmware update using the Multi-Loader tool</li> </ul>	<ul style="list-style-type: none"> <li>• Re-download application firmware.</li> </ul>
<b>F001</b>	Precharge	<ul style="list-style-type: none"> <li>• Charging relay control fault or charging resistor damaged</li> </ul>	<ul style="list-style-type: none"> <li>• Turn the drive off and then back on again.</li> <li>• Check the connections.</li> <li>• Check the stability of the main supply.</li> <li>• Contact local Schneider Electric representative.</li> </ul>
<b>F002</b>	Unknown drive rating	<ul style="list-style-type: none"> <li>• Power card and stored card versions different</li> </ul>	<ul style="list-style-type: none"> <li>• Contact local Schneider Electric representative.</li> </ul>
<b>F003</b>	Unknown or incompatible power board	<ul style="list-style-type: none"> <li>• The power card is incompatible with the control card</li> </ul>	<ul style="list-style-type: none"> <li>• Contact local Schneider Electric representative.</li> </ul>
<b>F004</b>	Internal serial link fault	<ul style="list-style-type: none"> <li>• Communication interruption between the internal cards</li> </ul>	<ul style="list-style-type: none"> <li>• Contact local Schneider Electric representative.</li> </ul>
<b>F005</b>	Invalid industrialization zone	<ul style="list-style-type: none"> <li>• Internal data inconsistent</li> </ul>	<ul style="list-style-type: none"> <li>• Contact local Schneider Electric representative.</li> </ul>
<b>F006</b>	Current measurement circuit	<ul style="list-style-type: none"> <li>• Current measurement is not correct due to hardware circuit fault</li> </ul>	<ul style="list-style-type: none"> <li>• Contact local Schneider Electric representative.</li> </ul>
<b>F007</b>	Internal thermal sensor detected fault	<ul style="list-style-type: none"> <li>• The drive temperature sensor is not operating correctly</li> <li>• The drive is in short circuit or open</li> </ul>	<ul style="list-style-type: none"> <li>• Contact local Schneider Electric representative.</li> </ul>
<b>F008</b>	Internal CPU	<ul style="list-style-type: none"> <li>• Internal microprocessor fault</li> </ul>	<ul style="list-style-type: none"> <li>• Turn the drive off and then back on again.</li> <li>• Contact local Schneider Electric representative.</li> </ul>

## Fault detection codes that cannot be cleared automatically (continued)

Code	Name	Possible causes	Remedy
<b>F 0 1 0</b>	Overcurrent	<ul style="list-style-type: none"> <li>Parameters in the <a href="#">Motor control menu 3 0 0</a> - page <a href="#">68</a> are not correct</li> <li>Inertia or load too high</li> <li>Mechanical locking</li> </ul>	<ul style="list-style-type: none"> <li>Check the parameters.</li> <li>Check the size of the motor/drive/load.</li> <li>Check the state of the mechanism.</li> <li>Connect line motor chokes.</li> <li>Reduce the <a href="#">Switching frequency range 3 1 5</a> page <a href="#">71</a>.</li> <li>Check the ground connection of drive, motor cable and motor insulation.</li> </ul>
<b>F 0 1 8</b>	Motor short-circuit	<ul style="list-style-type: none"> <li>Short-circuit or grounding at the drive output</li> <li>Ground fault while in run state</li> <li>Motor switching while in run state</li> <li>Significant current leakage to ground while several motors are connected in parallel</li> </ul>	<ul style="list-style-type: none"> <li>Verify the cables connecting the drive to the motor and the motor insulation.</li> <li>Adjust the switching frequency.</li> <li>Connect chokes in series with the motor.</li> <li>Verify the adjustment of speed loop.</li> </ul>
<b>F 0 1 9</b>	Ground short-circuit		
<b>F 0 2 0</b>	IGBT short circuit	<ul style="list-style-type: none"> <li>Internal power component short circuit detected at power on</li> </ul>	<ul style="list-style-type: none"> <li>Contact local Schneider Electric representative.</li> </ul>
<b>F 0 2 5</b>	Overspeed	<ul style="list-style-type: none"> <li>Instability</li> <li>Overspeed associated with the inertia of the application</li> </ul>	<ul style="list-style-type: none"> <li>Check the motor.</li> <li>If overspeed is 10% more than <a href="#">Top frequency 3 0 8</a> (page <a href="#">69</a>) adjust this parameter if necessary.</li> <li>Add a braking resistor.</li> <li>Check the size of the motor/drive/load.</li> <li>Check parameters of the speed loop (gain and stability).</li> </ul>
<b>F 0 2 8</b>	Autotuning fault	<ul style="list-style-type: none"> <li>Motor not connected to the drive</li> <li>Motor phase loss</li> <li>Special motor</li> <li>Motor is rotating (being driven by the load, for example)</li> </ul>	<ul style="list-style-type: none"> <li>Check that the motor/drive are compatible.</li> <li>Check that the motor is present during autotuning.</li> <li>If an output contactor is being used downstream, close it during auto-tuning.</li> <li>Check that the motor is completely stopped.</li> </ul>
<b>F 0 3 6</b>	Angle setting fault	<ul style="list-style-type: none"> <li>This occurs during the phase-shift angle measurement, if the motor phase is disconnected or if the motor inductance is too high.</li> </ul>	<ul style="list-style-type: none"> <li>Check the motor phases and the maximum current allowed by the drive.</li> </ul>

## Fault detection codes that can be cleared with the automatic restart function, after the cause has disappeared

These faults can also be cleared by turning on and off or by means of a logic input (parameter [Detected fault reset assignment 6 0 1](#) (page [111](#))).

F011, F013, F014, F015, F016, F022, F024 and F027 faults can be inhibited and cleared by means of a logic input [[Detected fault inhibition assignment 6 1 0](#) (page [116](#))].

Code	Name	Possible causes	Remedy
<b>F 0 0 9</b>	Overbraking	<ul style="list-style-type: none"> <li>Sudden braking or load inertia too high</li> </ul>	<ul style="list-style-type: none"> <li>Increase the deceleration time.</li> <li>Install a module unit with a braking resistor if necessary.</li> <li>Check the main supply voltage to ensure it is under the maximum acceptable (20% over maximum main supply during run status).</li> </ul>
<b>F 0 1 1</b>	Drive overheat	<ul style="list-style-type: none"> <li>Drive temperature too high</li> </ul>	<ul style="list-style-type: none"> <li>Check the motor load, the drive ventilation and the ambient temperature. Wait for the drive to cool down before restarting. See Mounting and temperature conditions on page <a href="#">20</a>.</li> </ul>
<b>F 0 1 2</b>	Process overload fault	<ul style="list-style-type: none"> <li>Process overload</li> </ul>	<ul style="list-style-type: none"> <li>Check that drive parameters and application processes are compatible.</li> </ul>
<b>F 0 1 3</b>	Motor overload	<ul style="list-style-type: none"> <li>Triggered by excessive motor current</li> </ul>	<ul style="list-style-type: none"> <li>Check configuration of motor thermal protection and motor load.</li> </ul>
<b>F 0 1 4</b>	1 Output phase loss	<ul style="list-style-type: none"> <li>Loss of one phase on drive output</li> </ul>	<ul style="list-style-type: none"> <li>Check the connections from the drive to the motor.</li> <li>If using a downstream contactor, make sure the connection, cable and contactor are right.</li> </ul>
<b>F 0 1 5</b>	3 Output phases loss	<ul style="list-style-type: none"> <li>Motor not connected</li> <li>Motor power too low, below 6% of the rated drive current</li> <li>Output contactor open</li> <li>Transient instability in the motor current</li> </ul>	<ul style="list-style-type: none"> <li>Check the connections from the drive to the motor.</li> <li>Test on a low power motor or without a motor. In factory settings mode, motor phase loss detection is active <a href="#">Output Phase loss detection 6 0 5</a> page <a href="#">114</a> = <a href="#">0 1</a>. To check the drive in a test or maintenance environment, without having to use a motor with the same rating as the drive, deactivate motor phase loss detection <a href="#">Output Phase loss detection 6 0 5</a> = <a href="#">0 0</a>.</li> <li>Check and optimize <a href="#">IR compensation 3 1 0</a> page <a href="#">70</a>, <a href="#">Rated motor voltage 3 0 4</a> page <a href="#">68</a> and <a href="#">Rated motor current 3 0 5</a> page <a href="#">69</a> and then perform <a href="#">Auto-tuning 3 1 8</a> page <a href="#">72</a>.</li> </ul>
<b>F 0 1 6</b>	Main overvoltage	<ul style="list-style-type: none"> <li>Line voltage too high:                             <ul style="list-style-type: none"> <li>At drive power on, supply is 10% over the maximum acceptable voltage level</li> <li>At power with no run command, 20% over maximal line supply</li> </ul> </li> <li>Disturbed mains supply</li> </ul>	<ul style="list-style-type: none"> <li>Turn Off the Drive. Check and adjust the line voltage. After line come back to nominal voltage (within tolerance) do power On.</li> <li>If intermittent <b>F 0 1 6</b> code appear, set R1 assignment <a href="#">2 0 5.0</a> to <a href="#">0 1</a> and it can be connected to upstream protection to avoid overvoltage in the drive. In this case LO1 can be used for others drive status see page <a href="#">63</a></li> </ul>
<b>F 0 1 7</b>	Input phase loss	<ul style="list-style-type: none"> <li>Drive incorrectly supplied or a fuse blown</li> <li>Failure of one phase</li> <li>3-phase ATV310 used on a single-phase line supply</li> <li>Unbalanced load</li> <li>This protection only operates with the drive on load</li> </ul>	<ul style="list-style-type: none"> <li>Check the power connection and the fuses.</li> <li>Use a 3-phase line supply.</li> <li>Disable reporting of this fault type by setting <a href="#">Input Phase loss detection detection 6 0 6</a> (page <a href="#">115</a>) to <a href="#">0 0</a>.</li> </ul>

## Fault detection codes that can be cleared with the automatic restart function, after the cause has disappeared (continued)

Code	Name	Possible causes	Remedy
F021	Load short circuit	<ul style="list-style-type: none"> <li>Short-circuit at drive output</li> <li>Short circuit detection at the run command or DC injection command if parameter <b>IGBT Test 608</b> (page 115) is set to <b>01</b></li> </ul>	<ul style="list-style-type: none"> <li>Check the cables connecting the drive to the motor and the condition of motor insulation.</li> </ul>
F022	Modbus interruption	<ul style="list-style-type: none"> <li>Interrupted communication on the Modbus network</li> </ul>	<ul style="list-style-type: none"> <li>Check the connections of communication bus.</li> <li>Check the time-out (parameter <b>Modbus time out 704</b> page 118).</li> <li>Refer to the Modbus user manual.</li> </ul>
F024	HMI communication	<ul style="list-style-type: none"> <li>Communication interruption with the external display terminal</li> </ul>	<ul style="list-style-type: none"> <li>Check the terminal connection.</li> </ul>
F026	PI feedback fault	<ul style="list-style-type: none"> <li>PID feedback below lower limit</li> </ul>	<ul style="list-style-type: none"> <li>Verify the PID function feedback.</li> <li>Verify the PID feedback supervision (parameter <b>PID feedback supervision 59.25</b> page 97) and time delay setting (parameter <b>PID supervision function time delay 59.23</b> page 97).</li> </ul>
F027	IGBT overheat	<ul style="list-style-type: none"> <li>Drive overheated</li> <li>IGBT internal temperature is too high for the ambient temperature and load .</li> </ul>	<ul style="list-style-type: none"> <li>Check the size of the load/motor/drive.</li> <li>Reduce the <b>Switching frequency 315</b> page 71.</li> <li>Wait for the drive to cool down before restarting.</li> </ul>
F029	Process underload fault	<ul style="list-style-type: none"> <li>Process underload</li> <li>Time that motor current is below the <b>Process underload threshold 211</b> (page 65) exceeds the <b>Process underload time delay 210</b> (page 65) to protect the application</li> </ul>	<ul style="list-style-type: none"> <li>Check that drive parameters and application processes are compatible.</li> </ul>
F033	A11 current loss	<p>Detected if:</p> <ul style="list-style-type: none"> <li>Analog input AI1 is configured as current</li> <li><b>A11 current scaling parameter of 0% 204.1</b> (page 63) is greater than 3 mA</li> <li>Analog input current is lower than 2 mA</li> </ul>	<ul style="list-style-type: none"> <li>Check the terminal connection.</li> </ul>

## Fault detection codes that will be cleared as soon as their causes disappear

USF faults can be inhibited and cleared remotely by means of a logic input parameter [Detected fault inhibition assignment 6 I 0](#) (page [116](#)).

Code	Name	Possible causes	Remedy
<b>F 0 3 0</b>	Undervoltage	<ul style="list-style-type: none"> <li>Line supply too low</li> <li>Transient voltage dip</li> </ul>	<ul style="list-style-type: none"> <li>Check the voltage and parameters on the <a href="#">Undervoltage phase loss menu 6 0 7</a> - (page <a href="#">115</a>).</li> </ul>
<b>F 0 3 1</b>	Incorrect configuration	<ul style="list-style-type: none"> <li>HMI block replaced by an HMI block configured on a drive with a different rating</li> <li>The current configuration of customer parameters is inconsistent</li> </ul>	<ul style="list-style-type: none"> <li>Return to factory settings or retrieve the backup configuration, if it is valid.</li> <li>If the fault remains after reverting to the factory settings, contact your local Schneider Electric representative.</li> </ul>
<b>F 0 3 2</b> (1)	Invalid configuration	<ul style="list-style-type: none"> <li>Invalid configuration</li> <li>The configuration loaded in the drive via the bus or communication network is inconsistent.</li> <li>The configuration upload has been interrupted or is not fully finished</li> </ul>	<ul style="list-style-type: none"> <li>Check the configuration loaded previously.</li> <li>Load a compatible configuration.</li> </ul>
<b>F 0 3 4</b>	Download invalid configuration	<ul style="list-style-type: none"> <li>When save parameter setting or restore to factory setting, the drive detect invalid configuration.</li> </ul>	<ul style="list-style-type: none"> <li>Power cycle drive.</li> <li>Restore to factory setting.</li> <li>If the fault remains after reverting to the factory settings, contact your local Schneider Electric representative.</li> </ul>

(1) When the CFI is present in the previous fault menu, it means the configuration has been interrupted or is not fully finished.

Some detected faults that are reset by pressing the RUN key

See [Reset all previous detected faults via Run key of HMI 6 I 4](#) parameter (page [117](#)).

### HMI block changed

When an HMI block is replaced by an HMI block configured on a drive with a different rating, the drive locks in Incorrect configuration **F 0 3 1** fault mode on power-up. If the card has been deliberately changed, the fault can be cleared by returning to factory setting.

## Fault detection codes displayed on the remote display terminal

Code	Name	Description
<b>in iE:</b>	Auto-initialization on start	<ul style="list-style-type: none"> <li>Macro controller initialization</li> <li>Searching communication configuration</li> </ul>
<b>CoM.E</b> (1)	Communication error	<ul style="list-style-type: none"> <li>50 ms time out error</li> <li>This message appears after 220 retry attempts</li> </ul>
<b>A - 17</b> (1)	Key alarm	<ul style="list-style-type: none"> <li>Key pressed down for longer than 10 seconds</li> <li>Membrane switch disconnected</li> <li>Display terminal woken up while a key is being pressed</li> </ul>
<b>c L r</b> (1)	Confirm fault reset	<ul style="list-style-type: none"> <li>This message appears if the STOP key is pressed while the display terminal is displaying a fault</li> </ul>
<b>dE u.E</b> (1)	Drive mismatch	<ul style="list-style-type: none"> <li>Drive type (brand) does not match display terminal type (brand)</li> </ul>
<b>r o M.E</b> (1)	ROM abnormality	<ul style="list-style-type: none"> <li>ROM abnormality detected by checksum calculation</li> </ul>
<b>r A M.E</b> (1)	RAM abnormality	<ul style="list-style-type: none"> <li>Display terminal RAM abnormality detected</li> </ul>
<b>C P u.E</b> (1)	Other fault	<ul style="list-style-type: none"> <li>The other detected fault</li> </ul>

(1) Flashing

## 2-wire type control (source)

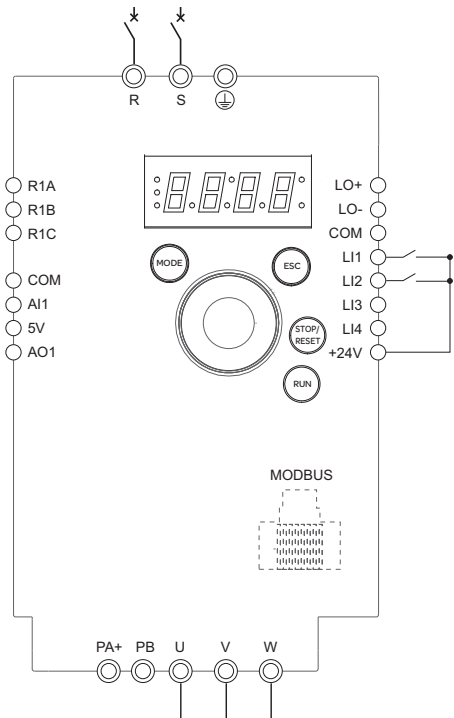

(a): Run Forward (b): Run Reverse

1. Connect the ground terminal to the grounding screws located below the output terminals.
2. Connect the power terminals.
3. Connect the logic inputs.
4. Turn on the drive without giving a run command.
5. Assign factory settings to the drive, i.e. **Factory / recall customer parameter set 102** (page 56) = **64**.
6. Set the motor parameters (in **CO nF** mode) only if the factory configuration of the drive is not suitable.
7. Perform an auto-tuning.
8. Set parameter **Reverse direction 503** (page 87) to **L 2H**.

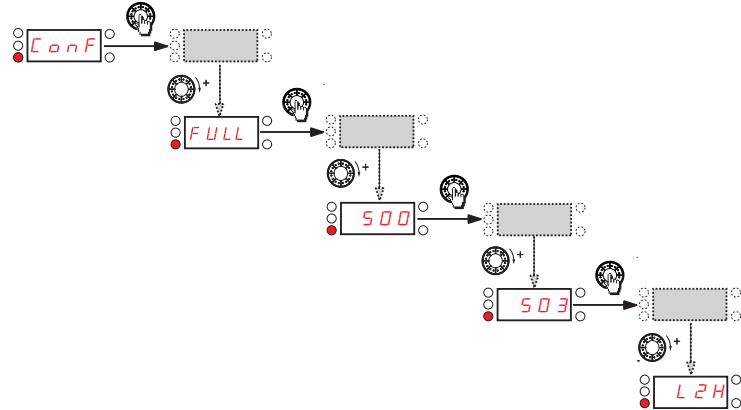

9. Start

## 2-wire control (sink)

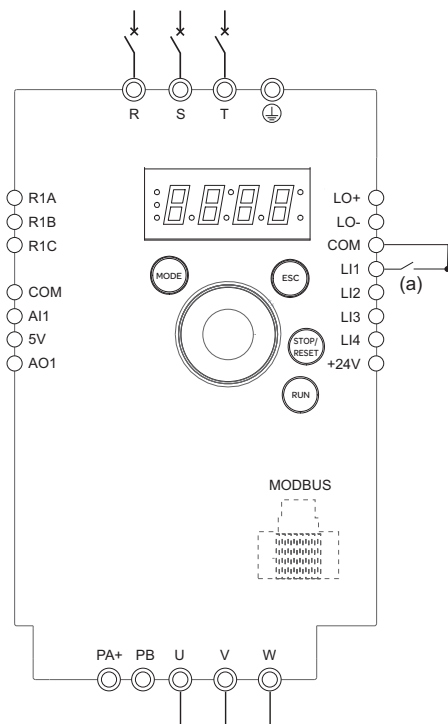

(a): Run Forward

1. Connect the ground terminal to the grounding screws located below the output terminals.
2. Connect the power terminals.
3. Connect the logic inputs.
4. Turn on the drive without giving a run command.
5. Assign factory settings to the drive, i.e. **Factory / recall customer parameter set 102** (page 56) = **64**.
6. Set **201** to **00** (see page 58).
7. Set the motor parameters (in **CO nF** mode) only if the factory configuration of the drive is not suitable.
8. Perform an auto-tuning.
9. Set parameter **Logic inputs type 203** (page 62) to **01**.

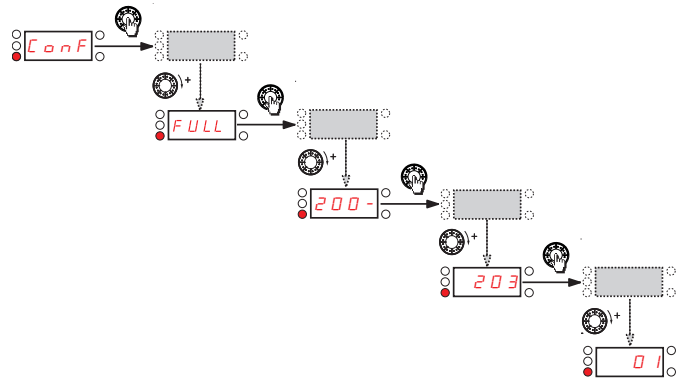

10. Start

## 3-wire control (sink)

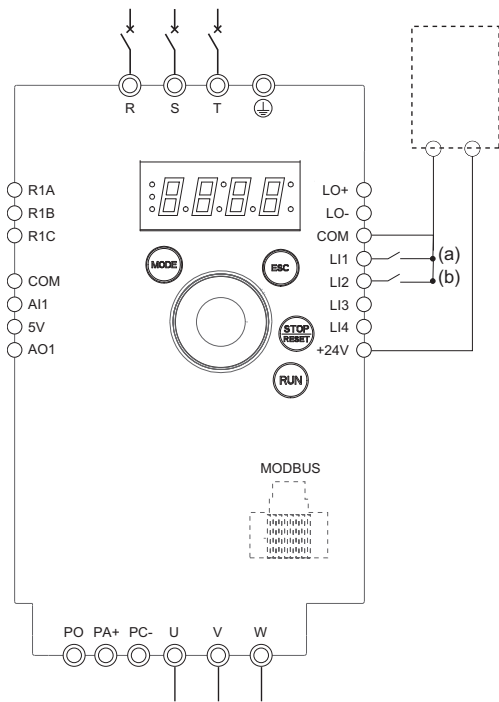

(a): Run Forward (b): Run Reverse

1. Connect the ground terminal to the grounding screws located below the output terminals.
2. Connect the power terminals.
3. Connect the logic inputs.
4. Turn on the drive without giving a run command.
5. Assign factory settings to the drive, i.e. **Factory / recall customer parameter set 102** (page 56) = **64**.
6. Set **201** to **01** (see page 58).
7. Set the motor parameters (in **CONF** mode) only if the factory configuration of the drive is not suitable.
8. Perform an auto-tuning.
9. Set parameter **Logic inputs type 203** (page 62) to **02**.

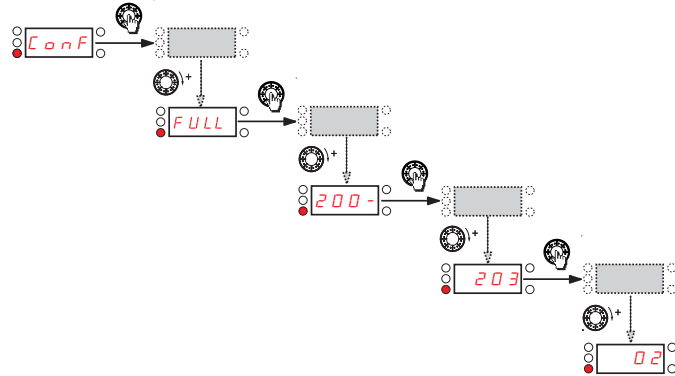

10. Start

## Speed control 0-20 mA (source)

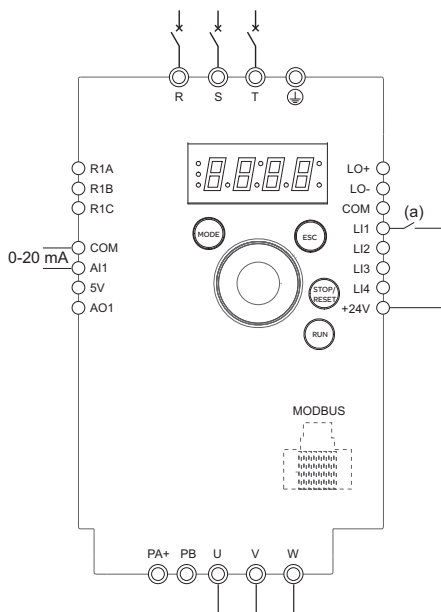

(a) Run Forward

1. Connect the ground terminal to the grounding screws located below the output terminals.
2. Connect the power terminals.
3. Connect the logic input LI1 and analog input AI1.
4. Turn on the drive without giving a run command.
5. Assign factory settings to the drive, i.e. **Factory / recall customer parameter set 102** (page 56) = **64**.
6. Set the motor parameters (in **CONF** mode) only if the factory configuration of the drive is not suitable.
7. Perform an auto-tuning.
8. Set **AI1 type 204.0** (page 63) to **0A**, **AI1 current scaling parameter of 0% 204.1** (page 63) to 0 A. Check that **AI1 current scaling parameter of 100% 204.2** (page 63) is set to 20 mA.

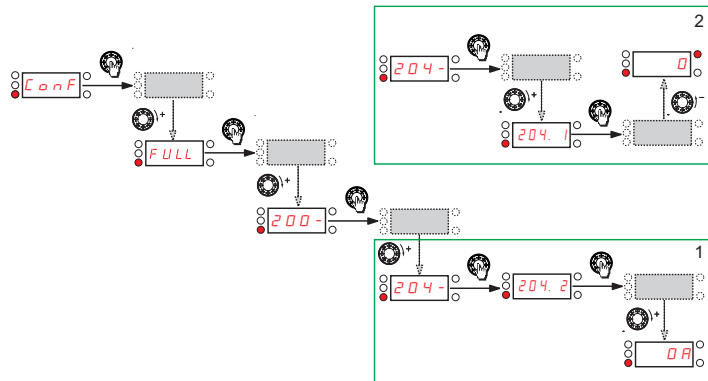

9. Start

## 4 preset speeds (source)

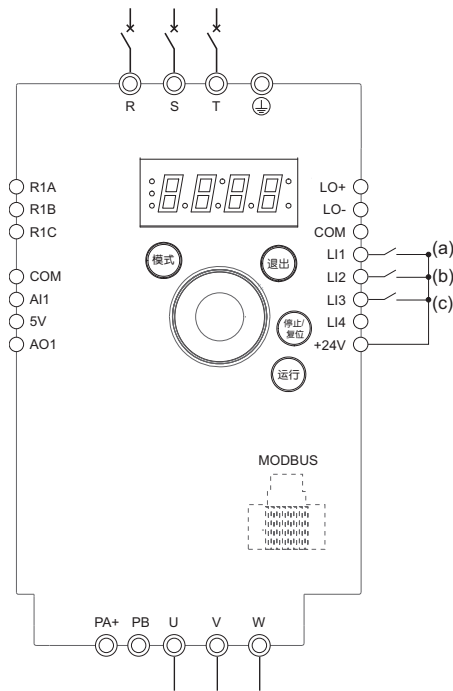

(a): Run Forward  
(b): 2 preset speeds (c): 4 preset speeds

**Important:** Please refer to Function compatibility table (page 46).

1. Connect the ground terminal to the grounding screws located below the output terminals.
2. Connect the power terminals.
3. Connect the logic inputs.
4. Turn on the drive without giving a run command.
5. Assign factory settings to the drive, i.e. **Factory / recall customer parameter set 102** (page 56) = **64**.
6. Set the motor parameters (in CONf mode) only if the factory configuration of the drive is not suitable.
7. Perform an auto-tuning.
8. Set **2 preset speeds 507.0** (page 92) to **L2H**.

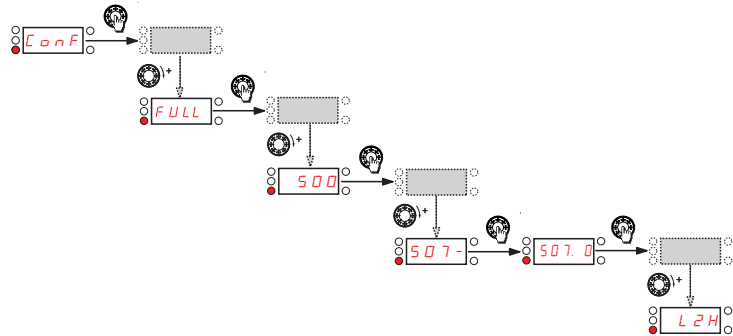

Set **Preset speed 2 507.3** (page 92) to 20 Hz.

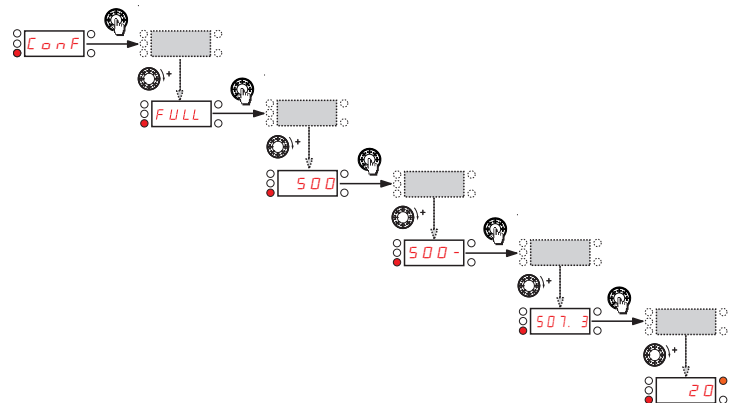

Set **preset speed 4 507.1** (page 92) to **L3H**.

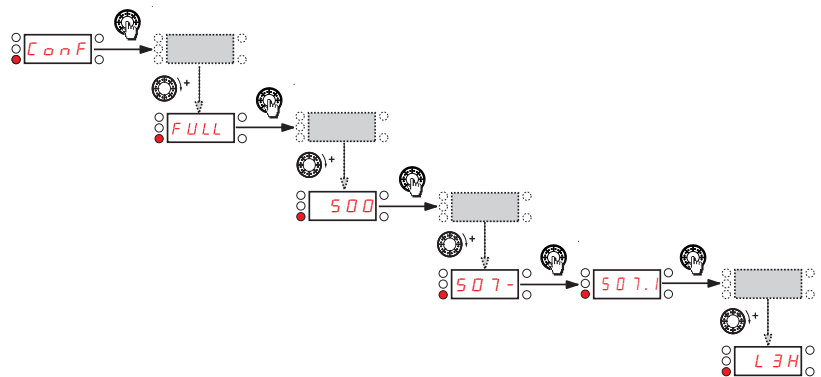

Set Preset speed 3 **5 0 7.4** (page [92](#)) to 30 Hz.

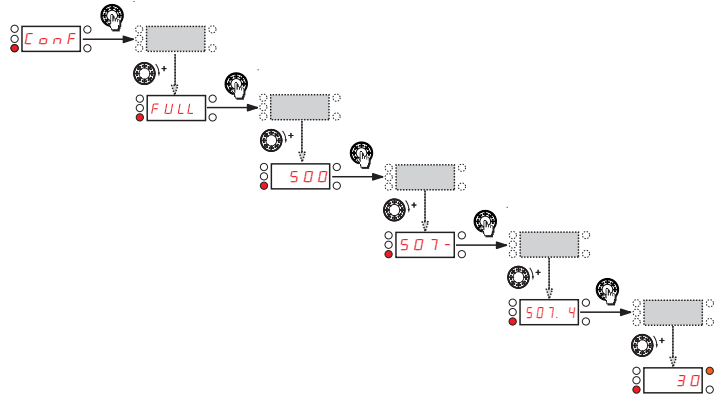

## 4 preset speeds (source) continued

Set **Preset speed 4 507.5** (page 92) to 40 Hz.

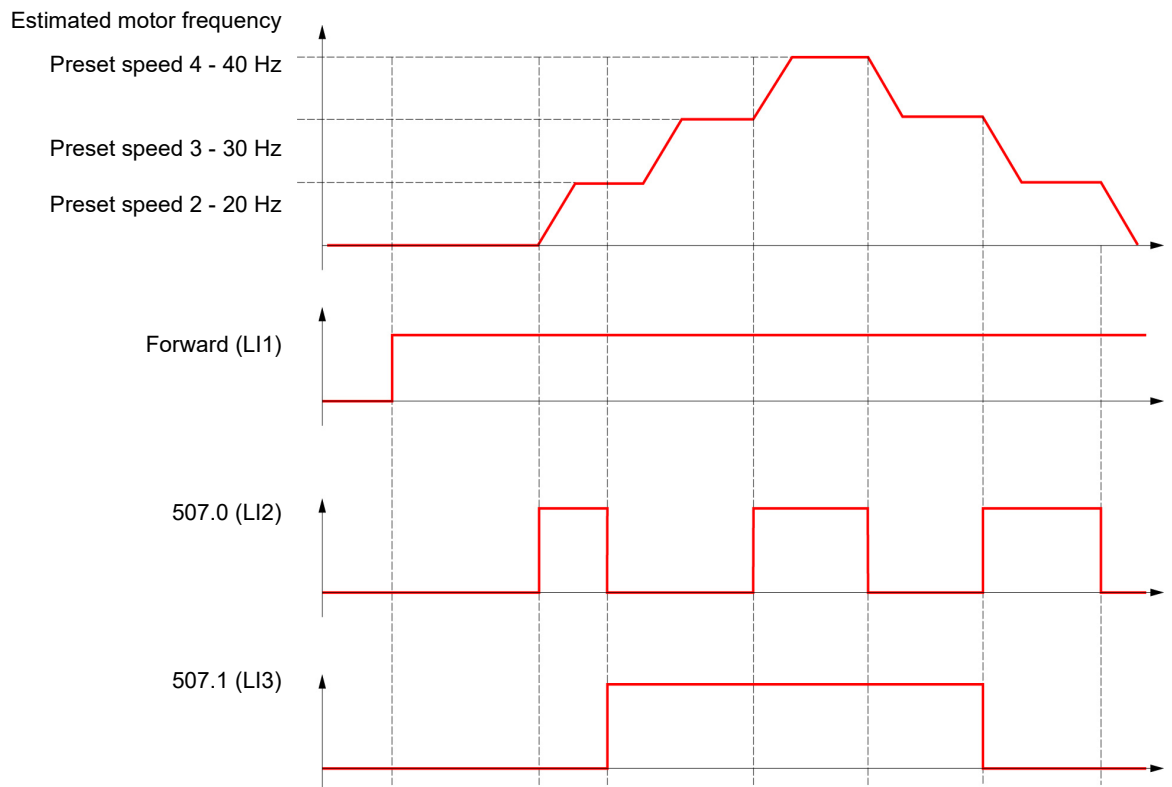
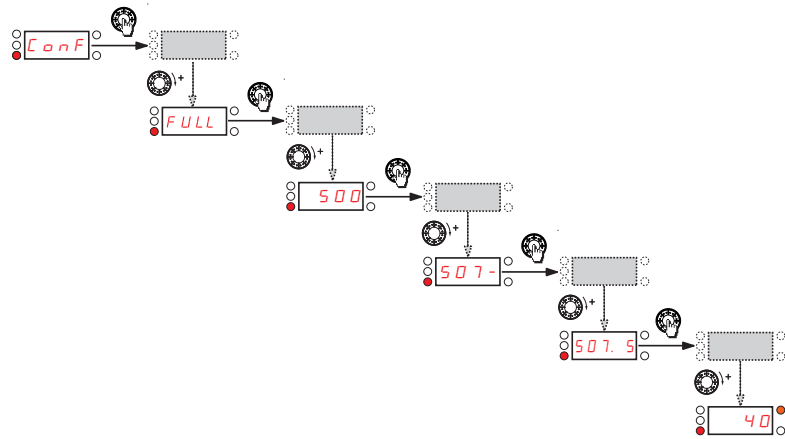

## Terminal command channel and Modbus reference channel

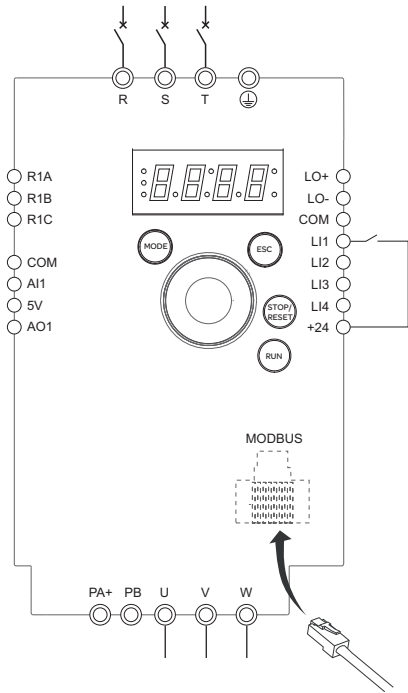

(a): Run Forward

**Important:** Please refer to the Function compatibility table (page 46).

1. Connect the ground terminal to the grounding screws located below the output terminals.
2. Connect the power terminals.
3. Connect the logic input L11 and plug RJ45 cable connector to the Modbus socket.
4. Turn on the drive without giving a run command.
5. Assign factory settings to the drive, i.e. set **Factory / recall customer parameter set 102** (page 56) to **64**.
6. Set the motor parameters (in CO<sub>N</sub>F mode) only if the factory configuration of the drive is not suitable.
7. Perform an auto-tuning.
8. Set **Channel configuration 406** (page 81) to **02**.

(a)

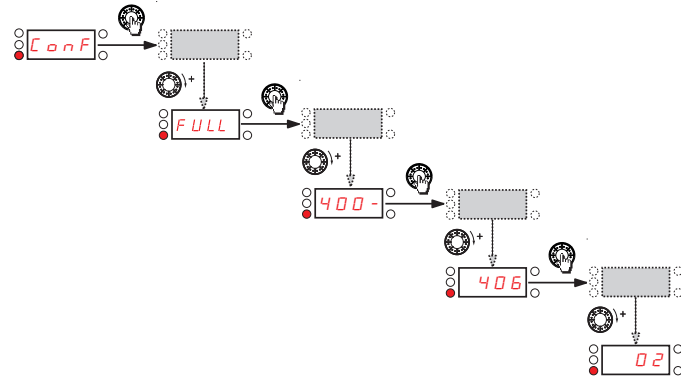

Set **Reference channel 1 401** (page 81) to **164**.

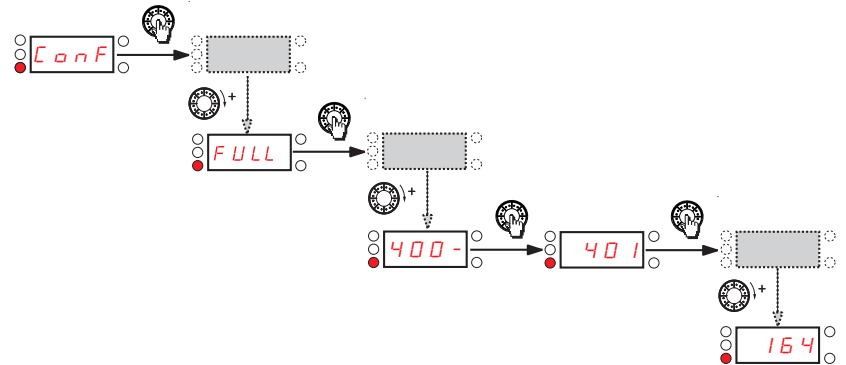

Check that **Command channel 1 407** (page 82) is set to **01**.

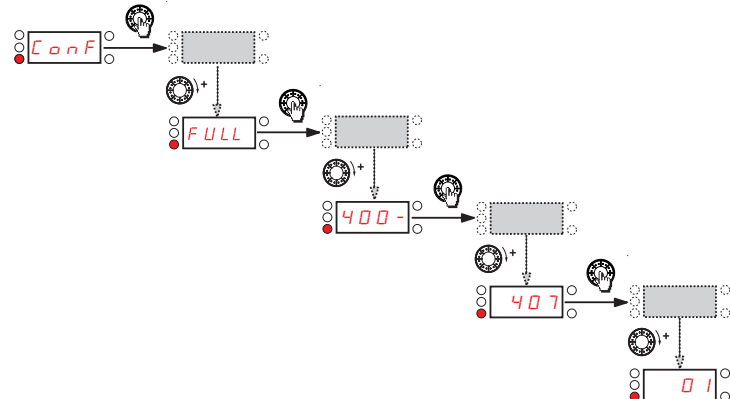

9. Start

## Introduction

### Overview

#### **DANGER**

##### **INSUFFICIENT PROTECTION AGAINST OVERCURRENTS CAN CAUSE FIRE OR EXPLOSION**

- Use properly rated overcurrent protection devices.
- Use the fuses/circuit breakers specified.
- Do not connect the product to a supply mains whose prospective short circuit current rating (current that flows during a short circuit) exceeds the specified maximum permissible value.
- When rating the upstream mains fuses and the cross sections as well as the lengths of the mains cables, take into account the minimum required prospective short-circuit current (Isc). Refer to the Upstream Protection Device section.
- If the minimum required prospective short-circuit current (Isc) is not available, apply the instructions given in the section below.

**Failure to follow these instructions will result in death or serious injury.**

The specified maximum permissible values and products for IEC compliance are specified in the present document (user manual).

### General

- The Short Circuit Protective Device (SCPD) rated to the drive will help protect the upstream installation in case of a short-circuit internal to the drive and mitigate the damage to the drive and its surrounding area.
- The SCPD rated to the drive is mandatory to help ensuring the safety of the Power Drive System.  
It comes in addition to the upstream branch circuit protection which is in compliance with the local regulation for electrical installation.
- The SCPD shall mitigate the damage in case of detected error condition such as an internal short-circuit of the drive.
- The SCPD must take into account both following characteristics...
  - a maximum prospective short-circuit current
  - a minimum required prospective short-circuit current (Isc).

If the minimum required prospective short-circuit current (Isc) is not available, increase the power of the transformer or decrease the length of the cables

In other cases, contact your Schneider Electric Customer Care Center (CCC) for specific selection of Short Circuit Protective Device (SCPD).

**NOTE:** The electronic power output short-circuit protection circuitry meets the requirements of IEC 60364-4-41:2005/AMD1 - Clause 411.

# Upstream Protective Device

---

## Wiring Diagram

This diagram shows an example of installation with both SCPD types, Circuit-breaker and Fuse link rated to the drive.

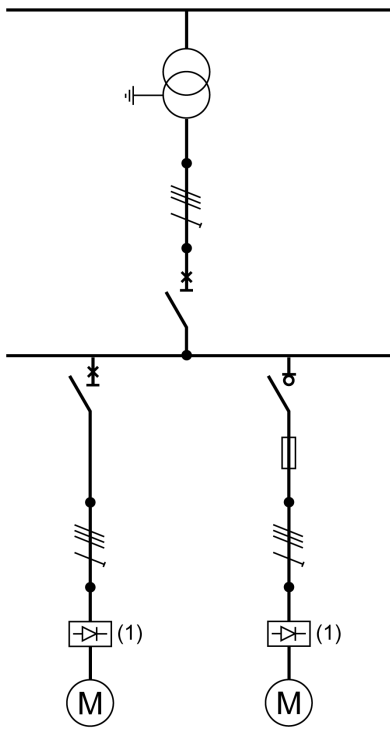

(1) Drive

## Prospective Short-Circuit Current

### Calculation

The prospective short-circuit current shall be computed at the drive connection points.

The following equations allow to estimate the value of the symmetrical three-phase prospective short-circuit current ( $I_{sc}$ ) at the drive connection points.

$$X_t = \frac{U^2}{S_n} \cdot usc$$

$$Z_{cc} = \sqrt{\left(\rho \cdot \frac{l}{S} + R_f\right)^2 + (X_t + X_c \cdot l + X_f)^2}$$

$$I_{sc} = \frac{U}{\sqrt{3}} \cdot \frac{1}{Z_{cc}}$$

<b><math>I_{sc}</math></b>	Symmetrical three-phase prospective short-circuit current (kA)
<b><math>X_t</math></b>	Transformer reactance
<b><math>U</math></b>	No-load phase to phase voltage of the transformer (V)
<b><math>S_n</math></b>	Apparent transformer power (kVA)
<b><math>usc</math></b>	Short-circuit voltage, according to the transformer data sheet (%)
<b><math>Z_{cc}</math></b>	Total short-circuit impedance (m $\Omega$ )
<b><math>\rho</math></b>	Conductor resistivity e.g. Cu: 0.01851 m $\Omega$ .mm
<b><math>l</math></b>	Conductor length (mm)
<b><math>S</math></b>	Conductor cross section (mm <sup>2</sup> )
<b><math>X_c</math></b>	Conductor lineic reactance (0.0001 m $\Omega$ /mm)
<b><math>R_f, X_f</math></b>	Resistance and reactance of the line filter (m $\Omega$ )

# Upstream Protective Device

## Example of Calculation with Copper Cable (without line filter)

Transformer 50 Hz	U 400 Vac Usc	Cable Cross Section	Isc depending on cable length in m(ft)							
			10 (33)	20 (66)	40 (131)	80 (262)	100 (328)	160 (525)	200 (656)	320 (1050)
kVA	%	mm <sup>2</sup> (AWG)	kA	kA	kA	kA	kA	kA	kA	kA
100	4	2.5 (14)	2.3	1.4	0.8	0.4	0.3	0.2	0.2	0.1
		4 (12)	2.9	2.0	1.2	0.6	0.5	0.3	0.2	0.2
		6 (10)	3.2	2.6	1.6	0.9	0.7	0.5	0.4	0.2
		10 (8)	3.4	3.1	2.3	1.4	1.2	0.8	0.6	0.4
		25 (4)	3.5	3.4	3.1	2.5	2.2	1.6	1.4	0.9
		50 (0)	3.5	3.5	3.3	3.0	2.8	2.3	2.1	1.5
		70 (00)	3.5	3.5	3.4	3.1	2.9	2.6	2.3	1.8
		120 (250 MCM)	3.6	3.5	3.4	3.2	3.1	2.8	2.6	2.1
250	4	6 (10)	5.7	3.4	1.8	0.9	0.7	0.5	0.4	0.2
		10 (8)	7.1	5.0	2.9	1.5	1.2	0.8	0.6	0.4
		25 (4)	8.4	7.4	5.5	3.4	2.8	1.8	1.5	0.9
		50 (0)	8.6	8.1	7.0	5.2	4.5	3.2	2.7	1.8
		70 (00)	8.6	8.2	7.3	5.8	5.2	3.9	3.3	2.3
		120 (250 MCM)	8.7	8.3	7.6	6.5	6.0	4.8	4.2	3.0
400	4	6 (10)	6.6	3.6	1.8	0.9	0.7	0.5	0.4	0.2
		10 (8)	9.2	5.6	3.0	1.5	1.2	0.8	0.6	0.4
		25 (4)	12	9.9	6.5	3.6	2.9	1.9	1.5	1.0
		50 (0)	13	12	9.3	6.1	5.1	3.4	2.8	1.8
		70 (00)	13	12	10	7.2	6.2	4.4	3.6	2.4
		120 (250 MCM)	13	13	11	8.6	7.6	5.7	4.9	3.4
800	6	6 (10)	6.9	3.7	1.9	0.9	0.7	0.5	0.4	0.2
		10 (8)	10	5.8	3.0	1.5	1.2	0.8	0.6	0.4
		25 (4)	15	11	6.9	3.7	3.0	1.9	1.5	1.0
		50 (0)	17	15	11	6.5	5.4	3.5	2.9	1.8
		70 (00)	17	15	12	7.9	6.7	4.6	3.7	2.4
		120 (250 MCM)	17	16	13	9.8	8.6	6.2	5.2	3.5
1,000	6	6 (10)	7.1	3.7	1.9	0.9	0.7	0.5	0.4	0.2
		10 (8)	11	6.0	3.1	1.5	1.2	0.8	0.6	0.4
		25 (4)	18	12	7.1	3.7	3.0	1.9	1.5	1.0
		50 (0)	21	17	12	6.7	5.5	3.6	2.9	1.8
		70 (00)	21	18	13	8.4	7.0	4.7	3.8	2.4
		120 (250 MCM)	22	19	16	11	9.3	6.5	5.4	3.6

# Upstream Protective Device

---

## Additional Line Filter Option

If a line input filter option is required for the installation such as a line reactor or a passive harmonic filter, the minimum prospective short-circuit current capability of the source is reduced at the drive connection point and shall be estimated (see Calculation, page [138](#)) with the impedance values given in the table below.

Then, the SCPD type shall be selected according to the drive. If no selection is available, Schneider Electric Customer Care Center (CCC) should be contacted.

EMC filter series have no significant effect on the minimum prospective shortcircuit current capability of the main source. Through the line option, the  $I_{sc}$  will be limited to a maximum value independent of the transformer and cable. **Therefore the below equations can be used to estimate the minimum prospective short-circuit current capability.**

$$10 \text{ m}\Omega \leq X_f \leq 400 \text{ m}\Omega \quad \Rightarrow \quad I_{sc_{\text{maxi}}} (\text{kA}) = 4.7 - 0.7 \cdot \text{Log} (X_f)$$

$$400 \text{ m}\Omega \leq X_f \leq 2000 \text{ m}\Omega \quad \Rightarrow \quad I_{sc_{\text{maxi}}} (\text{kA}) = 2.05 - 0.26 \cdot \text{Log}(X_f)$$

Log: Natural logarithm

# Upstream Protective Device

## IEC Fuses

### Introduction



#### HAZARD OF ELECTRIC SHOCK, EXPLOSION, OR FIRE

The opening of the branch-circuit protective device is able to be an indication that a fault current has been interrupted.

- Current-carrying parts and other components of the controller should be examined and replaced if damaged.
- If burnout of the current element of an overload relay occurs, the complete overload relay must be replaced.

**Failure to follow these instructions will result in death or serious injury.**

**NOTE:** Only gR and gS fuses are mandatory in case of using braking ports, to comply with IEC 61800-5-1 Ed 2.1.

### Short Circuit Current Ratings: Selection Table

The amp rating of the short circuit protection devices in the table are maximum values with **Enclosure**, in **Normal Duty**. Smaller amp sizes may be used; particularly for Heavy Duty ratings.

**NOTE:**

- Integral solid state short circuit protection in the drive does not provide branch circuit protection. Branch circuit protection must be provided in accordance with any local codes.
- The drive has a 100 kA interrupt rating on the output of the drive. In addition to providing a rating based on shorting the output of the drive, these short circuit current ratings have been obtained by shorting components internal to the drive. These ratings allow proper coordination of short circuit protection.

**NOTE:** Verify that the minimum required prospective short-circuit current (Isc) value from the table above is lower than the value estimated in the Calculation section, page [138](#).

### 690 Vac Three phase (50/60Hz)

**NOTE:** Suitable for use on a circuit capable of delivering not more than   X   rms symmetrical kiloAmperes, **690 Vac** Volts maximum, when protected by   Z1   with a maximum rating of   Z2  .

Current limiting fuses can be chosen as SCPD according to the following table for both Normal duty (ND) and Heavy duty (HD):

Reference	Fuse TYPE	Minimum Size	Nominal Voltage	Nominal current (Z1, Z2)	I <sup>2</sup> t	SCCR (X)	
			(V)	(A)		(A <sup>2</sup> s)	Min (A)
ATV310H037N4•	gR	10x38	690	4	6.48	100	5
ATV310H075N4•	gR	10x38	690	6	22	100	5
ATV310HU15N4•	gR	10x38	690	12.5	50	200	5
ATV310HU22N4•	gR	10x38	690	16	78	200	5
ATV310HU30N4•	gR	10x38	690	20	137	200	5
ATV310HU40N4•	gR	10x38	690	25	238	300	5
ATV310HU55N4•	gR	14x51	690	40	609	500	22
ATV310HU75N4•	gR	14x51	690	40	609	500	22
ATV310HD11N4•	gS	000	690	63	881	1000	22
ATV310HD15N4•	gS	000	690	80	1741	1500	22
ATV310HD18N4•	gS	1	690	100	2747	1500	22
ATV310HD22N4•	gS	00	690	125	6185	1500	22



