



## 1 Download The Manuals

You must have detailed information to be able to carry out the installation and commissioning. This information can be found in the following manuals that can be downloaded on [www.se.com](http://www.se.com) or scan the QR code in front of the Drive.

- The ATV610 Installation manual (EAV64381)
- The ATV610 Programming manual (EAV64387)

The Getting Started manual does not replace the Installation and the Programming manuals.



Verify the Key Points of your installation, identified by this symbol.



## DANGER

### HAZARD OF ELECTRIC SHOCK, EXPLOSION, OR ARC FLASH

Only appropriately trained persons who are familiar with and understand the contents of this manual and all other pertinent product documentation and who have received safety training to recognize and avoid hazards involved are authorized to work on and with this drive system. Installation, adjustment, repair and maintenance must be performed by qualified personnel.

- The system integrator is responsible for compliance with all local and national electrical code requirements as well as all other applicable regulations with respect to grounding of all equipment.
- Many components of the product, including the printed circuit boards, operate with mains voltage.
- Only use properly rated, electrically insulated tools and measuring equipment.
- Do not touch unshielded components or terminals with voltage present.
- Motors can generate voltage when the shaft is rotated. Prior to performing any type of work on the drive system, block the motor shaft to prevent rotation.
- AC voltage can couple voltage to unused conductors in the motor cable. Insulate both ends of unused conductors of the motor cable.
- Do not short across the DC bus terminals or the DC bus capacitors or the braking resistor terminals.
- Before performing work on the drive system:
  - Disconnect all power, including external control power that may be present. Take into account that the circuit breaker or main switch does not de-energize all circuits.
  - Place a Do Not Turn On label on all power switches related to the drive system.
  - Lock all power switches in the open position.
  - Wait 15 minutes to allow the DC bus capacitors to discharge.
  - Follow the instructions given in the chapter "Verifying the Absence of Voltage" in the installation manual of the product.
- Before applying voltage to the drive system:
  - Verify that the work has been completed and that the entire installation cannot cause hazards.
  - If the mains input terminals and the motor output terminals have been grounded and short-circuited, remove the ground and the short circuits on the mains input terminals and the motor output terminals.
  - Verify proper grounding of all equipment.
  - Verify that all protective equipment such as covers, doors, grids is installed and/or closed.

**Failure to follow these instructions will result in death or serious injury.**

Electrical equipment should be installed, operated, serviced, and maintained only by qualified personnel. No responsibility is assumed by Schneider Electric for any consequences arising out of the use of this product.

## 2 Verify The Delivery Of The Drive

Unpack the drive and verify that it has not been damaged.

Damaged products or accessories may cause electric shock or unanticipated equipment operation.

## DANGER

### ELECTRIC SHOCK OR UNANTICIPATED EQUIPMENT OPERATION

Do not use damaged products or accessories.  
Failure to follow these instructions will result in death or serious injury.

Contact your local Schneider Electric sales office if you detect any damage whatsoever.

Verify compatibility between your drive and your application.  
See the ATV610 Catalog [DIA2ED2140702EN](http://DIA2ED2140702EN).



### Environment

- Degree of protection: **IP20, IP00 (frame size 6, 7, 8A, 8B)**
- Mechanical class conforming to IEC/EN 60721: 3S3 (3S2 for frame size 7, 8A, and 8B)
- Chemical class conforming to IEC/EN 60721: 3C3 (3C2 for frame size 7, 8A, and 8B)

## 3 Mount The Drive Vertically

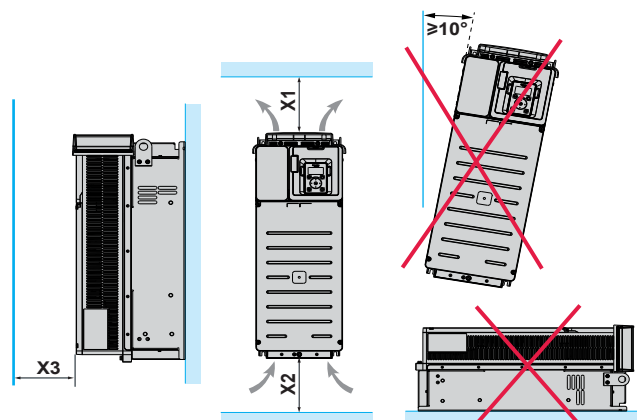

Drive	X1	X2	X3
ATV610U07N4... ATV610D90N4	≥ 100 mm (3.9 in.)	≥ 100 mm (3.9 in.)	≥ 10 mm (0.39 in.)
ATV610C11N4... ATV610C16N4	≥ 250 mm (10 in.)	≥ 250 mm (10 in.)	≥ 100 mm (3.94 in.)
ATV610C22N4... ATV610C40N4	≥ 200 mm (7.9 in.)	≥ 150 mm (5.9 in.)	≥ 10 mm (0.39 in.)

For a surrounding air temperature up to 45 °C (113 °F), 40 °C (104 °F) for frame size 7, 8A, and 8B. For other thermal conditions, see installation manual (EAV64381) on [www.se.com](http://www.se.com)

# 4 Connect The Drive: Power Part

## Ground the drive

Frame Size 1 and 2:

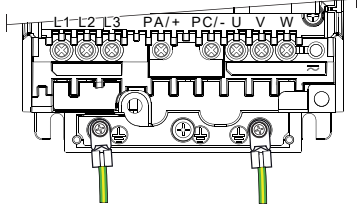

Frame Size 3:

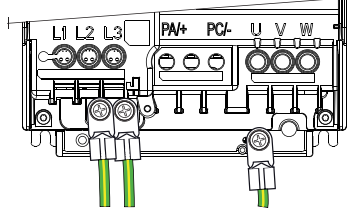

Frame Size 4 and 5:

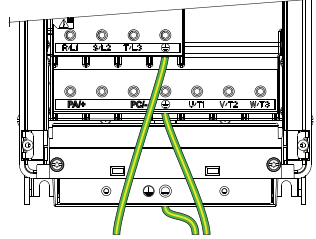

Frame Size 6:

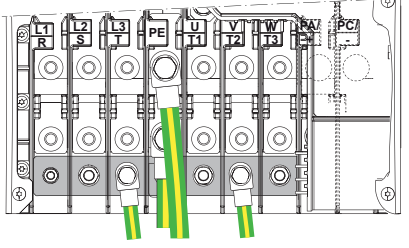

Frame Size 7:

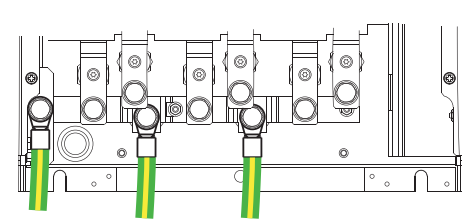

Frame Size 8A:

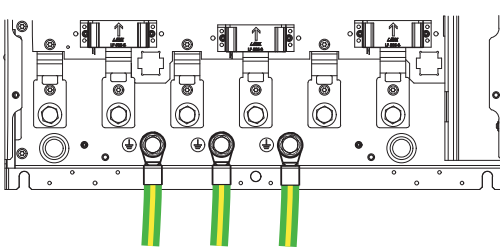

Frame Size 8B:

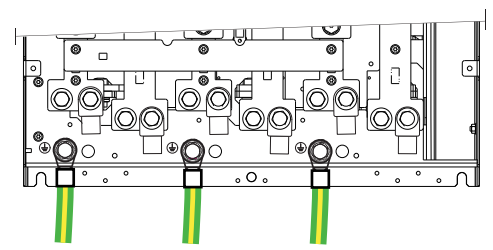

## Verify the ratings

- Verify circuit breaker rating or fuse rating (see the ATV610 Catalog [DIA2ED2140702EN](#)).
- Verify that the nominal motor voltage is compatible with the drive voltage. Nominal motor voltage \_\_\_\_\_ volts.

## Cable the power part

Minimum distance between the cables

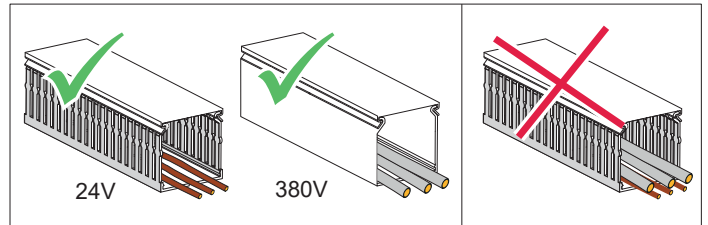
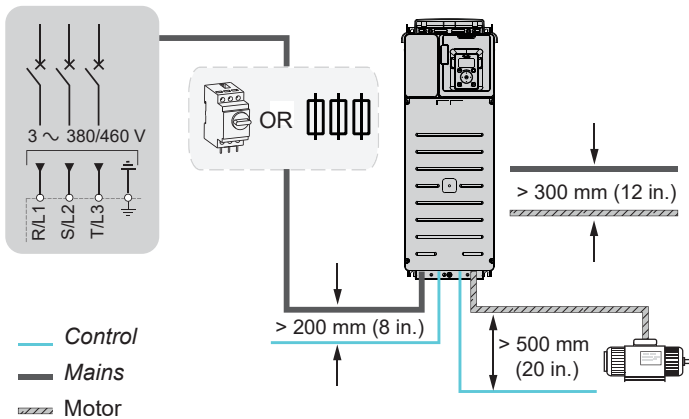

Download the white paper [An Improved Approach for Connecting VSD and Electric Motors \(998-2095-10-17-13AR0\\_EN\)](#).

## Tightening torque

Refer to the tightening torque instructions on the name plate.

xx N.m xx lb-in



**Altivar 610**  
 ATV610D18N4  
 V1.0 IE 00 18.5kW

U(V) Input	380-460Φ3
Output	0...380-460Φ3
F(Hz) Input	50/60
Output	0...500
I(A) Input	37.2MAX
Output	39.2

Made in China | Schneider Electric Industries SAS | 35 Rue Joseph Morier | FR-92500 Rosny-Maillon

## Stripping lengths

Refer to the instructions given in the installation manual ([EAV64381](#))

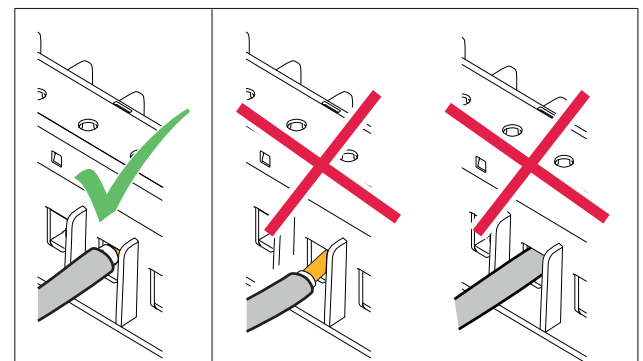

# 5 Connect The Drive: Control Part

- Several [Macro Config] are possible depending of your application
- the step 5 explains the connection wiring with a drive powered-off
  - the step 7 explains the access to the [Macro Config] menu

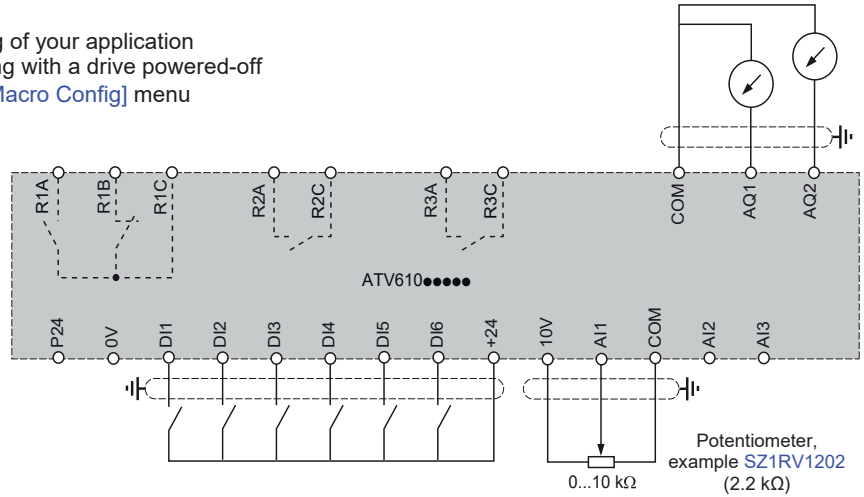
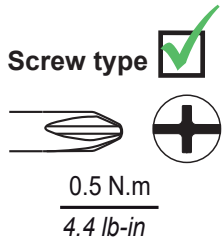

## Sink (SK) - Sink External (EXT) - Source (SRC)

SOURCE position is used for PLC outputs with PNP transistors. Refer to the instructions given in the installation manual (EAV64381).  
Default value: right position -SRC mode.



## Modbus Connection

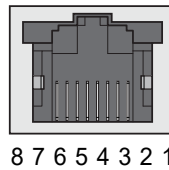
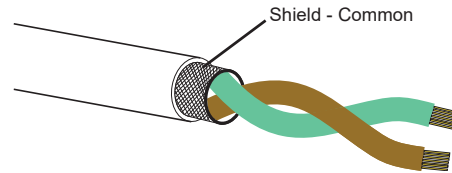
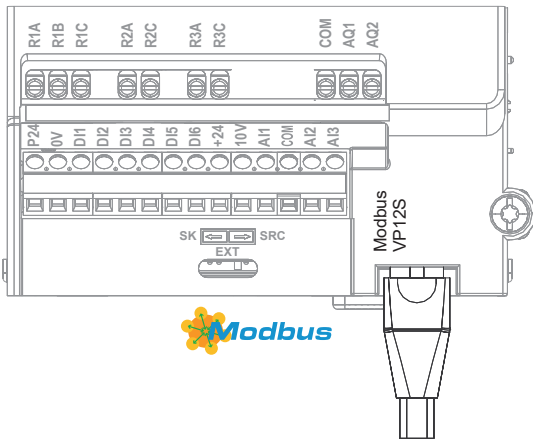

Pin	Signal
1	Reserved
2	
3	
4	D1 Modbus signal
5	D0 Modbus signal
6	-
7	VP, 10 Vdc (1)
8	Common Modbus signal

(1) Supply for RS232 / RS485 converter or a remote terminal

## Assignment of the inputs/outputs according to [Macro Config] CFG

The drive offers quick programming using macro configurations that correspond to different applications or uses.

Input/output	[Macro Config] CFG						
	[Start/stop] BSTS Factory setting	[Auto/manual] BAMB	[PID controller] BPID	[Preset speed] BPSP	[Modbus communication] BMBC	[Multi-pump 1] BMP1	[Multi-pump 2] BMP2
DI1	[Start/Stop]	[Forward]	[Forward]	[Start/Stop]	[Start/Stop]	[Start/Stop]	[Start/Stop]
DI2	[Fault Reset]	[Reverse] (Manual)	Not assigned	[Fault Reset]	[Fault Reset]	Not assigned	Not assigned
DI3	Not assigned	Not assigned	Not assigned	[2 Preset speeds]	[Ref Freq 2 switching]	Not assigned	Not assigned
DI4	Not assigned	[Ref Freq 2 Switching]	Not assigned	[4 Preset speeds]	Not assigned	Not assigned	Not assigned
DI5	Not assigned	Not assigned	Not assigned	Not assigned	Not assigned	Not assigned	Not assigned
DI6	Not assigned	Not assigned	Not assigned	Not assigned	Not assigned	Not assigned	Not assigned
AI1	[Ref Freq Channel 1] 0...10 Vdc	[Ref Freq Channel 1] 0...10 Vdc (Manual)	[PID ref.]	[Ref Freq Channel 1] 0...10 Vdc	[Ref Freq Channel 2] 0...10 Vdc	[PID ref.]	[PID ref.]
AI2	Not assigned	[Ref Freq Channel 2] 4...20 mA (Auto)	[PID feedback]	Not assigned	Not assigned	[PID feedback]	[PID feedback]
AQ1	[Motor frequency] 4...20 mA	[Motor frequency] 4...20 mA	[Motor frequency] 4...20 mA	[Motor frequency] 4...20 mA	[Motor frequency] 4...20 mA	[Motor frequency] 4...20 mA	[Motor frequency] 4...20 mA
AQ2	[Motor current] 4...20 mA	[Motor current] 4...20 mA	[Motor current] 4...20 mA	[Motor current] 4...20 mA	[Motor current] 4...20 mA	[Motor current] 4...20 mA	[Motor current] 4...20 mA
R1	[Operating state Fault]	[Operating state Fault]	[Operating state Fault]	[Operating state Fault]	[Operating state Fault]	[Operating state Fault]	[Operating state Fault]
R2	[Drive Running]	[Drive Running]	[Drive Running]	[Drive Running]	[Drive Running]	[Pump 2 Cmd]	[Pump 1 Cmd]
R3	Not assigned	Not assigned	Not assigned	Not assigned	Not assigned	[Pump 3 Cmd]	[Pump 2 Cmd]

## 6 Plain Text Display Terminal and LEDs: Description

1 LEDs	Signaling LEDs, see table below.
2 ESC	Used to quit a menu/parameter or remove the currently displayed value in order to revert to the previous value retained in the memory.
3 Touch wheel (OK - arrows)	Used to save the current value or access the selected menu/parameter. The touch wheel is used to scroll fast into the menus. Up/down arrows are used for precise selections, right/left arrows are used to select digits when setting a numerical value of a parameter.
4 STOP/RESET	Stop command / apply a Fault Reset.
5 Home	Access directly the home page.
6 RUN	Run command

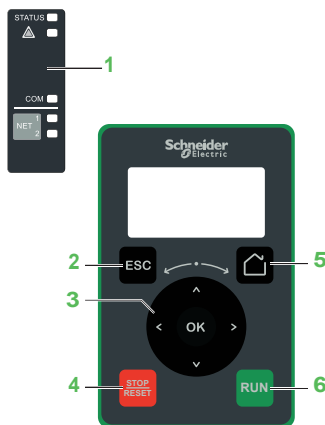

LED	LED Color	LED status	Drive status
STATUS	Green	Blinking	Ready
		Flickering	Acceleration or deceleration
		On	Running
△	Red	Blinking	Warning
		On	Operating State Fault
COM	Yellow	Blinking	Modbus communication active
NET 1 NET 2	Green	On	Fieldbus module: communication active
		Red	Fieldbus module: communication detected error
		Blinking	Fieldbus module: Incorrect settings

## 7 [Macro Config] and [Simply start] Parameters

- Verify that digital inputs are not active (DI1 see step 5 drawing).
- Apply power to the drive.
- Select [Simply start] menu
- Select [Macro Config] and select the configuration compatible with the wiring used (step 5 )
- Set [Simply Start] Parameters.

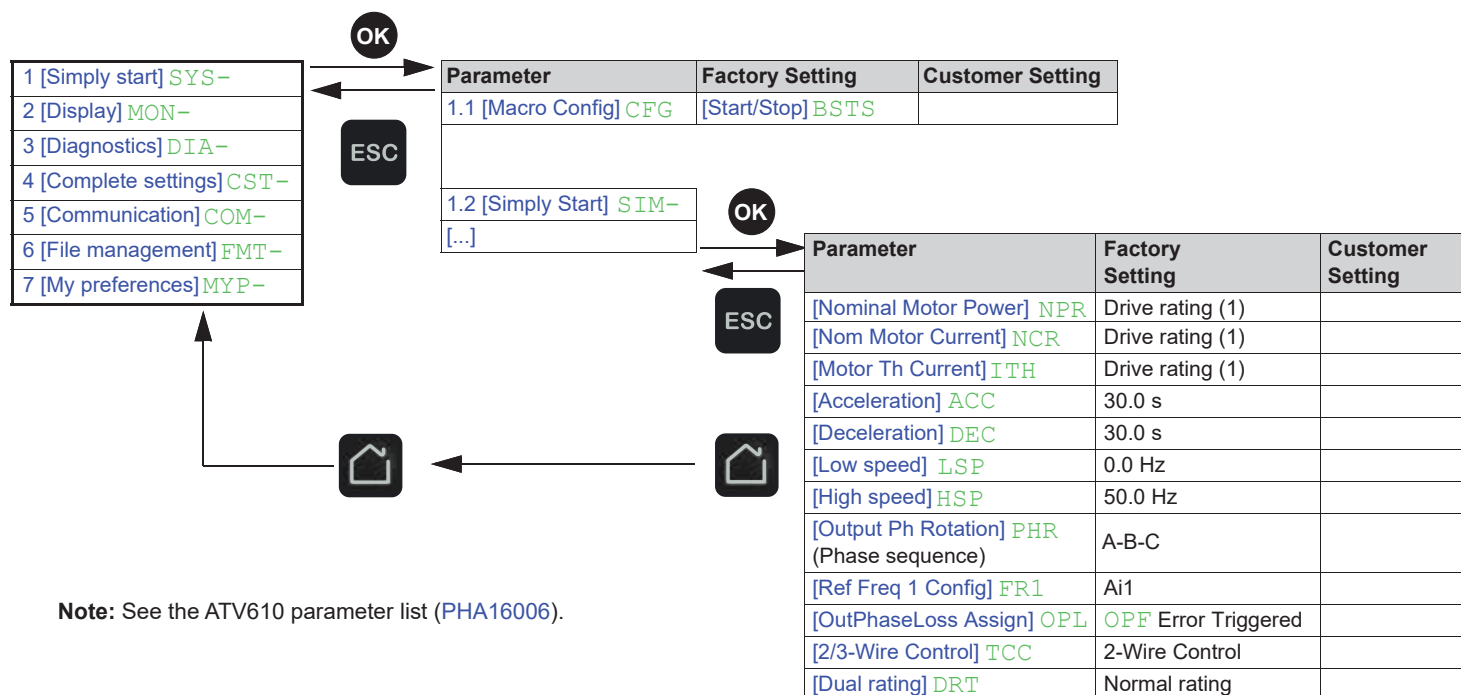

**Note:** See the ATV610 parameter list (PHA16006).

(1) See on the motor nameplate to set the following parameters

## 8 Start The Motor

- Switch on DI1 (forward) or DI2 (reverse).
- Use the potentiometer on AI1 to set the reference frequency, adjustable from [Low speed] LSP to [High speed] HSP .

## Troubleshooting

Scan the QR code in front of the drive to open the ATV610 programming manual (EAV64387) and select *Diagnostics and Troubleshooting* chapter.



### Leakage Current trouble

The drives have a built-in EMC filter. As a result they exhibit leakage current to ground. If the leakage current creates compatibility problems with your installation (residual current device or other), then you can reduce the leakage current by disconnecting the built-in EMC filter. Refer to the instructions given in installation manual (EAV64381).