

# Altivar Process 600

## Variable Speed Drives for Asynchronous and Synchronous motors

### DeviceNet Manual - VW3A3609

08/2016



---

The information provided in this documentation contains general descriptions and/or technical characteristics of the performance of the products contained herein. This documentation is not intended as a substitute for and is not to be used for determining suitability or reliability of these products for specific user applications. It is the duty of any such user or integrator to perform the appropriate and complete risk analysis, evaluation and testing of the products with respect to the relevant specific application or use thereof. Neither Schneider Electric nor any of its affiliates or subsidiaries shall be responsible or liable for misuse of the information contained herein. If you have any suggestions for improvements or amendments or have found errors in this publication, please notify us.

No part of this document may be reproduced in any form or by any means, electronic or mechanical, including photocopying, without express written permission of Schneider Electric.

All pertinent state, regional, and local safety regulations must be observed when installing and using this product. For reasons of safety and to help ensure compliance with documented system data, only the manufacturer should perform repairs to components.

When devices are used for applications with technical safety requirements, the relevant instructions must be followed.

Failure to use Schneider Electric software or approved software with our hardware products may result in injury, harm, or improper operating results.

Failure to observe this information can result in injury or equipment damage.

© 2016 Schneider Electric. All Rights Reserved.

# Table of Contents



	<b>Safety Information</b> .....	5
	<b>About the Book</b> .....	9
<b>Chapter 1</b>	<b>Presentation</b> .....	11
	Hardware Overview .....	12
	Software Overview .....	13
<b>Chapter 2</b>	<b>Basics</b> .....	15
2.1	Message Types for Fieldbus Communication .....	16
	Introduction .....	17
	Cyclical Exchanges (Implicit Exchanges) .....	18
	Messaging (Explicit Exchanges) .....	22
2.2	CIP Object .....	23
	Supported Classes .....	24
	Identity Object .....	25
	Message Router Object .....	27
	DeviceNet Object .....	28
	Assembly Object .....	29
	Connection Object .....	33
	Motor Data Object .....	38
	Control Supervisor Object .....	39
	AC/DC Drive Object .....	41
	Acknowledge Handler Object .....	43
	Application Objects .....	44
	DeviceNet Interface Object .....	46
<b>Chapter 3</b>	<b>Hardware Setup</b> .....	47
	Hardware Presentation .....	48
	Firmware and Description File .....	49
	Installation of the Module .....	50
	Electrical Installation .....	51
	Cable Routing Practices .....	52
	Accessories Presentation .....	54
<b>Chapter 4</b>	<b>Software Setup</b> .....	55
4.1	Basic Settings .....	56
	Introduction .....	57
	<b>[Address] <i>AdrC</i></b> .....	58
	<b>[Bit Rate] <i>bdr</i></b> .....	59
	<b>[Data rate used] <i>bdr u</i></b> .....	60
4.2	Additional Settings .....	61
	<b>[Conf. Assembly] <i>CIA</i></b> .....	62
	<b>[Scan.Out1 address] <i>CA1</i></b> .....	63
	<b>[Scan.Out2 address] <i>CA2</i></b> .....	64
	<b>[Scan.Out3 address] <i>CA3</i></b> .....	65
	<b>[Scan.Out4 address] <i>CA4</i></b> .....	66
	<b>[Scan. IN1 address] <i>PI1</i></b> .....	67
	<b>[Scan. IN2 address] <i>PI2</i></b> .....	68
	<b>[Scan. IN3 address] <i>PI3</i></b> .....	69
	<b>[Scan.IN4 address] <i>PI4</i></b> .....	70
4.3	Profile .....	71
	Definition of a Profile .....	72
	Functional Profiles Supported by the Drive .....	73
	Functional Description .....	74
	CIA402 Operating State Diagram .....	75

	Description of Operating States .....	76
	Summary .....	78
	Cmd Register <i>C P d</i> .....	79
	Stop Commands .....	80
	Assigning Control Word Bits .....	81
	[CiA402 State Reg] <i>E L R</i> .....	82
	Starting Sequence .....	83
	Sequence for a Drive Powered by the Power Stage Supply .....	84
	Sequence for a Drive with Separate Control Stage .....	86
	Sequence for a Drive with Mains Contactor Control .....	88
	Available Profiles with the VWA3609 Fieldbus Module .....	90
	Control with Communication Scanner .....	91
	Control According to ODVA AC Drive Profile .....	92
4.4	Fieldbus Integration Tutorial .....	94
	EDS Integration .....	95
	Drive Configuration .....	98
	Acyclic Messaging from Control Logix PLC .....	100
<b>Chapter 5</b>	<b>Operations</b> .....	<b>101</b>
5.1	Operating States .....	102
	Configuring Communication Error Response .....	102
5.2	Operating Modes .....	103
	Available Configurations .....	104
	Control Via DeviceNet in I/O Profile .....	105
	Control Via DeviceNet or Via the Terminals in I/O Profile .....	106
	Control Via DeviceNet in Drivecom Profile .....	107
	Control Via DeviceNet or the Terminals in CiA402 Profile .....	108
	Control in Drivecom Profile Via DeviceNet and Setpoint Switching at the Terminals .....	109
<b>Chapter 6</b>	<b>Diagnostics and Troubleshooting</b> .....	<b>111</b>
	Fieldbus Status LEDs .....	112
	Connection for Fieldbus Mode .....	115
	Monitoring of Communication Channel .....	116
	Communication Interruption .....	118
<b>Glossary</b>	.....	<b>119</b>



## Important Information

### NOTICE

Read these instructions carefully, and look at the equipment to become familiar with the device before trying to install, operate, service, or maintain it. The following special messages may appear throughout this documentation or on the equipment to warn of potential hazards or to call attention to information that clarifies or simplifies a procedure.



The addition of this symbol to a “Danger” or “Warning” safety label indicates that an electrical hazard exists which will result in personal injury if the instructions are not followed.



This is the safety alert symbol. It is used to alert you to potential personal injury hazards. Obey all safety messages that follow this symbol to avoid possible injury or death.

### **DANGER**

**DANGER** indicates a hazardous situation which, if not avoided, **will result in** death or serious injury.

### **WARNING**

**WARNING** indicates a hazardous situation which, if not avoided, **could result in** death or serious injury.

### **CAUTION**

**CAUTION** indicates a hazardous situation which, if not avoided, **could result in** minor or moderate injury.

### **NOTICE**

**NOTICE** is used to address practices not related to physical injury.

### PLEASE NOTE

Electrical equipment should be installed, operated, serviced, and maintained only by qualified personnel. No responsibility is assumed by Schneider Electric for any consequences arising out of the use of this material.

A qualified person is one who has skills and knowledge related to the construction and operation of electrical equipment and its installation, and has received safety training to recognize and avoid the hazards involved.

### Qualification Of Personnel

Only appropriately trained persons who are familiar with and understand the contents of this manual and all other pertinent product documentation are authorized to work on and with this product. In addition, these persons must have received safety training to recognize and avoid hazards involved. These persons must have sufficient technical training, knowledge and experience and be able to foresee and detect potential hazards that may be caused by using the product, by changing the settings and by the mechanical, electrical and electronic equipment of the entire system in which the product is used. All persons working on and with the product must be fully familiar with all applicable standards, directives, and accident prevention regulations when performing such work.

## Intended Use

This product is a drive for three-phase synchronous and asynchronous motors and intended for industrial use according to this manual. The product may only be used in compliance with all applicable safety standard and local regulations and directives, the specified requirements and the technical data. The product must be installed outside the hazardous ATEX zone. Prior to using the product, you must perform a risk assessment in view of the planned application. Based on the results, the appropriate safety measures must be implemented. Since the product is used as a component in an entire system, you must ensure the safety of persons by means of the design of this entire system (for example, machine design). Any use other than the use explicitly permitted is prohibited and can result in hazards. Electrical equipment should be installed, operated, serviced, and maintained only by qualified personnel.

## Product Related Information

**Read and understand these instructions before performing any procedure with this drive.**

 <b>DANGER</b>
<b>HAZARD OF ELECTRIC SHOCK, EXPLOSION OR ARC FLASH</b>
<ul style="list-style-type: none"><li>• Only appropriately trained persons who are familiar with and understand the contents of this manual and all other pertinent product documentation and who have received safety training to recognize and avoid hazards involved are authorized to work on and with this drive system. Installation, adjustment, repair and maintenance must be performed by qualified personnel.</li><li>• The system integrator is responsible for compliance with all local and national electrical code requirements as well as all other applicable regulations with respect to grounding of all equipment.</li><li>• Many components of the product, including the printed circuit boards, operate with mains voltage. Do not touch. Use only electrically insulated tools.</li><li>• Do not touch unshielded components or terminals with voltage present.</li><li>• Motors can generate voltage when the shaft is rotated. Prior to performing any type of work on the drive system, block the motor shaft to prevent rotation.</li><li>• AC voltage can couple voltage to unused conductors in the motor cable. Insulate both ends of unused conductors of the motor cable.</li><li>• Do not short across the DC bus terminals or the DC bus capacitors or the braking resistor terminals.</li><li>• Before performing work on the drive system:<ul style="list-style-type: none"><li>○ Disconnect all power, including external control power that may be present.</li><li>○ Place a <b>Do Not Turn On</b> label on all power switches.</li><li>○ Lock all power switches in the open position.</li><li>○ Wait 15 minutes to allow the DC bus capacitors to discharge. The DC bus LED is not an indicator of the absence of DC bus voltage that can exceed 800 Vdc.</li><li>○ Measure the voltage on the DC bus between the DC bus terminals (PA/+, PC/-) using a properly rated voltmeter to verify that the voltage is &lt; 42 Vdc.</li><li>○ If the DC bus capacitors do not discharge properly, contact your local Schneider Electric representative. Do not repair or operate the product.</li></ul></li><li>• Install and close all covers before applying voltage.</li></ul>
<b>Failure to follow these instructions will result in death or serious injury.</b>

Drive systems may perform unexpected movements because of incorrect wiring, incorrect settings, incorrect data or other errors.

 <b>WARNING</b>
<b>UNANTICIPATED EQUIPMENT OPERATION</b>
<ul style="list-style-type: none"><li>• Carefully install the wiring in accordance with the EMC requirements.</li><li>• Do not operate the product with unknown or unsuitable settings or data.</li><li>• Perform a comprehensive commissioning test.</li></ul>
<b>Failure to follow these instructions can result in death, serious injury, or equipment damage.</b>

Damaged products or accessories may cause electric shock or unanticipated equipment operation.

## DANGER

### ELECTRIC SHOCK OR UNANTICIPATED EQUIPMENT OPERATION

Do not use damaged products or accessories.

**Failure to follow these instructions will result in death or serious injury.**

Contact your local Schneider Electric sales office if you detect any damage whatsoever.

## WARNING

### LOSS OF CONTROL

- The designer of any control scheme must consider the potential failure modes of control paths and, for critical control functions, provide a means to achieve a safe state during and after a path failure. Examples of critical control functions are emergency stop, overtravel stop, power outage and restart.
- Separate or redundant control paths must be provided for critical control functions.
- System control paths may include communication links. Consideration must be given to the implications of unanticipated transmission delays or failures of the link.
- Observe all accident prevention regulations and local safety guidelines (1).
- Each implementation of the product must be individually and thoroughly tested for proper operation before being placed into service.

**Failure to follow these instructions can result in death, serious injury, or equipment damage.**

(1) For USA: Additional information, refer to NEMA ICS 1.1 (latest edition), Safety Guidelines for the Application, Installation, and Maintenance of Solid State Control and to NEMA ICS 7.1 (latest edition), Safety Standards for Construction and Guide for Selection, Installation and Operation of Adjustable-Speed Drive Systems.

## *NOTICE*

### DESTRUCTION DUE TO INCORRECT MAINS VOLTAGE

Before switching on and configuring the product, verify that it is approved for the mains voltage

**Failure to follow these instructions can result in equipment damage.**

The temperature of the products described in this manual may exceed 80 °C (176 °F) during operation.

## WARNING

### HOT SURFACES

- Ensure that any contact with hot surfaces is avoided.
- Do not allow flammable or heat-sensitive parts in the immediate vicinity of hot surfaces.
- Verify that the product has sufficiently cooled down before handling it.
- Verify that the heat dissipation is sufficient by performing a test run under maximum load conditions.

**Failure to follow these instructions can result in death, serious injury, or equipment damage.**

This equipment has been designed to operate outside of any hazardous location. Only install this equipment in zones known to be free of a hazardous atmosphere.

## DANGER

### POTENTIAL FOR EXPLOSION

Install and use this equipment in non-hazardous locations only.

**Failure to follow these instructions will result in death or serious injury.**

Machines, controllers, and related equipment are usually integrated into networks. Unauthorized persons and malware may gain access to the machine as well as to other devices on the network/fieldbus of the machine and connected networks via insufficiently secure access to software and networks.

---

## **WARNING**

### **UNAUTHORIZED ACCESS TO THE MACHINE VIA SOFTWARE AND NETWORKS**

- In your hazard and risk analysis, consider all hazards that result from access to and operation on the network/fieldbus and develop an appropriate cyber security concept.
- Verify that the hardware infrastructure and the software infrastructure into which the machine is integrated as well as all organizational measures and rules covering access to this infrastructure consider the results of the hazard and risk analysis and are implemented according to best practices and standards covering IT security and cyber security (such as: ISO/IEC 27000 series, Common Criteria for Information Technology Security Evaluation, ISO/ IEC 15408, IEC 62351, ISA/IEC 62443, NIST Cybersecurity Framework, Information Security Forum - Standard of Good Practice for Information Security).
- Verify the effectiveness of your IT security and cyber security systems using appropriate, proven methods.

**Failure to follow these instructions can result in death, serious injury, or equipment damage.**





## At a Glance

### Document Scope

The purpose of this document is to:

- show you how to install the DeviceNet fieldbus on your drive.
- show you how to configure drive to use DeviceNet for display and control.

**NOTE:** Read and understand this document and all related documents (see below) before installing, operating, or maintaining your drive.

### Validity Note

This documentation is valid for the Altivar process DeviceNet fieldbus.

The technical characteristics of the devices described in this document also appear online. To access this information online:

Step	Action
1	Go to the Schneider Electric home page <a href="http://www.schneider-electric.com">www.schneider-electric.com</a> .
2	In the <b>Search</b> box type the reference of a product or the name of a product range. <ul style="list-style-type: none"><li>• Do not include blank spaces in the reference or product range.</li><li>• To get information on grouping similar modules, use asterisks ( * ).</li></ul>
3	If you entered a reference, go to the <b>Product Datasheets</b> search results and click on the reference that interests you. If you entered the name of a product range, go to the <b>Product Ranges</b> search results and click on the product range that interests you.
4	If more than one reference appears in the <b>Products</b> search results, click on the reference that interests you.
5	Depending on the size of your screen, you may need to scroll down to see the data sheet.
6	To save or print a data sheet as a .pdf file, click <b>Download XXX product datasheet</b> .

The characteristics that are presented in this manual should be the same as those characteristics that appear online. In line with our policy of constant improvement, we may revise content over time to improve clarity and accuracy. If you see a difference between the manual and online information, use the online information as your reference.

### Related Documents

Use your tablet or your PC to quickly access detailed and comprehensive information on all our products on [www.schneider-electric.com](http://www.schneider-electric.com)

The internet site provides the information you need for products and solutions

- The whole catalog for detailed characteristics and selection guides
- The CAD files to help design your installation, available in over 20 different file formats
- All software and firmware to maintain your installation up to date
- A large quantity of White Papers, Environment documents, Application solutions, Specifications... to gain a better understanding of our electrical systems and equipment or automation
- And finally all the User Guides related to your drive, listed below:

Title of Documentation	Reference Number
Altivar Process ATV600 Getting Started	<a href="#">EAV63253</a> (English), <a href="#">EAV63254</a> (French), <a href="#">EAV63255</a> (German), <a href="#">EAV63256</a> (Spanish), <a href="#">EAV64310</a> (Italian), <a href="#">EAV64298</a> (Chinese)
Altivar Process ATV600 Getting Started Annex (SCCR)	<a href="#">EAV64300</a> (English)
Altivar Process ATV630, ATV650 Installation Manual	<a href="#">EAV64301</a> (English), <a href="#">EAV64302</a> (French), <a href="#">EAV64306</a> (German), <a href="#">EAV64307</a> (Spanish), <a href="#">EAV63257</a> (Italian), <a href="#">EAV64317</a> (Chinese)

Title of Documentation	Reference Number
Altivar Process ATV630, ATV650 Programming Manual	<a href="#">EAV64318</a> (English), <a href="#">EAV64320</a> (French), <a href="#">EAV64321</a> (German), <a href="#">EAV64322</a> (Spanish), <a href="#">EAV64323</a> (Italian), <a href="#">EAV64324</a> (Chinese)
Altivar Process ATV600 Modbus Serial Link Manual (Embedded)	<a href="#">EAV64325</a> (English)
Altivar Process ATV600 Ethernet Manual (Embedded)	<a href="#">EAV64327</a> (English)
Altivar Process ATV600 Ethernet IP - Modbus TCP Manual (VW3A3720, VW3A3721)	<a href="#">EAV64328</a> (English)
Altivar Process ATV600 PROFIBUS DP manual (VW3A3607)	<a href="#">EAV64329</a> (English)
Altivar Process ATV600 DeviceNet manual (VW3A3609)	<a href="#">EAV64330</a> (English)
Altivar Process ATV600 PROFINET manual (VW3A3627)	<a href="#">EAV64331</a> (English)
Altivar Process ATV600 CANopen Manual (VW3A3608, 618, 628)	<a href="#">EAV64333</a> (English)
Altivar Process ATV600 Communication Parameters	<a href="#">EAV64332</a> (English)
Altivar Process ATV600 Safety Function manual	<a href="#">EAV64334</a> (English)

You can download these technical publications and other technical information from our website at <http://download.schneider-electric.com>

## Terminology

The technical terms, terminology, and the corresponding descriptions in this manual normally use the terms or definitions in the relevant standards.

The technical terms, terminology, and the corresponding descriptions in this manual normally use the terms or definitions in the relevant standards.

Among others, these standards include:

- IEC 61800 series: Adjustable speed electrical power drive systems
- IEC 61508 Ed.2 series: Functional safety of electrical/electronic/programmable electronic safety-related
- EN 954-1 Safety of machinery - Safety related parts of control systems
- EN ISO 13849-1 & 2 Safety of machinery - Safety related parts of control systems.
- IEC 61158 series: Industrial communication networks - Fieldbus specifications
- IEC 61784 series: Industrial communication networks - Profiles
- IEC 60204-1: Safety of machinery - Electrical equipment of machines – Part 1: General requirements

In addition, the term **zone of operation** is used in conjunction with the description of specific hazards, and is defined as it is for a **hazard zone** or **danger zone** in the EC Machinery Directive (2006/42/EC) and in ISO 12100-1.

Also see the glossary at the end of this manual.

---

# Chapter 1

## Presentation

---

### What Is in This Chapter?

This chapter contains the following topics:

Topic	Page
Hardware Overview	12
Software Overview	13

## Hardware Overview

### General

The VW3A3609 fieldbus module enables the integration of a drive into a DeviceNet industrial fieldbus. This fieldbus module offers the possibility to control the drive in its native profile or with several AC drive profiles from the ODVA:

The figure shows the hardware presentation of the VW3A3609 DeviceNet fieldbus module:



## Software Overview

### General

The following figure provides the basic software overview of the DeviceNet fieldbus module:

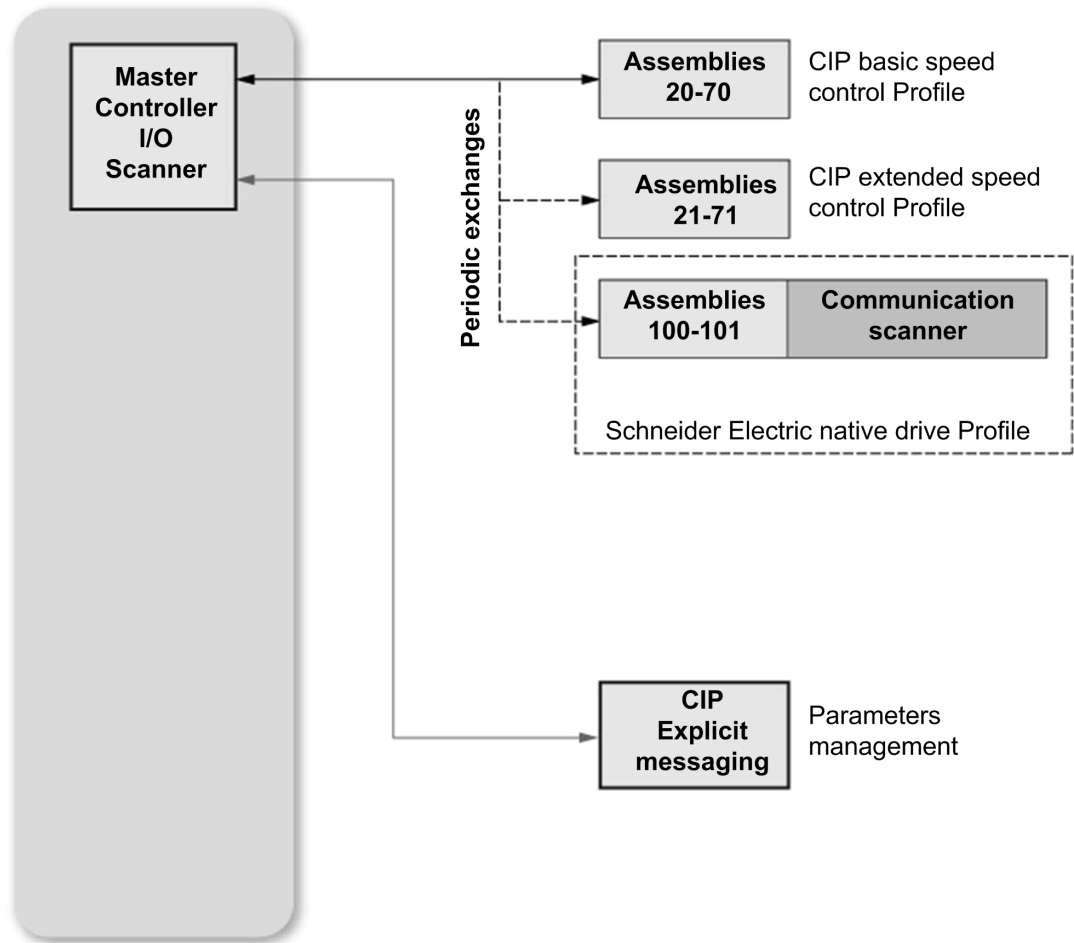

The DeviceNet fieldbus module is compliant with the ODVA drive profile. It supports the following profiles:

- CIP basic speed control
- CIP extended speed control
- Drive native profile (IEC 61800-7 CiA402) and I/O profile only for assembly 100, 101. In addition to these cyclic exchanges, the fieldbus module also supports explicit messaging.



---

# Chapter 2

## Basics

---

### What Is in This Chapter?

This chapter contains the following sections:

Section	Topic	Page
2.1	Message Types for Fieldbus Communication	16
2.2	CIP Object	23

## Section 2.1

### Message Types for Fieldbus Communication

---

#### What Is in This Section?

This section contains the following topics:

Topic	Page
Introduction	17
Cyclical Exchanges (Implicit Exchanges)	18
Messaging (Explicit Exchanges)	22



---

## Introduction

### Supported Message Types

DeviceNet industrial fieldbus defines several message types for communication.

The VW3A3609 fieldbus module supports two message types

- Implicit exchanges
- Explicit exchanges

### Implicit Exchange

The implicit exchange is used for cyclical exchange with the drive. It allows reading or writing several drive parameter values by the use of assemblies.

### Explicit Exchange

The explicit exchange is used for messaging exchange with the drive. It allows reading or writing a single drive parameter value.

## Cyclical Exchanges (Implicit Exchanges)

### Overview

This part gives a description of the assembly sets and how to configure them.

### Principle of Control Configuration

By the configuration of the control, it is possible to decide from which channel the drive receives its commands and reference frequency, either permanently or depending on a switching command. Numerous configurations are possible. For more information, refer to the programming manual and communication parameters excel file.

### Control with Communication Scanner

If the default assemblies selected are 100 and 101, the drive can be used in all profiles and modes

- I/O profile
- CiA402 profile with separate or non separate mode.

By configuring the communication scanner, it is possible to assign any relevant parameter of the drive to the 4 input and 4 output variables of the assemblies.

- **Assembly 100: Native Drive Output**

The following table provides the output assembly mapping:

Word number	Definition
0	Control word
1	Speed reference (rpm)
3	Scanner write word 3
4	Scanner write word 4

The following table describes the ATV600 assignment:

Word number	Code	Description
1	[Scan.Out1 address]	Communication scanner, value of write word 1 (default value: CMD, Control word)
2	[Scan.Out2 address]	Communication scanner, value of write word 2 (default value: LFRD, Speed reference)
3	[Scan.Out3 address]	Communication scanner, value of write word 3
4	[Scan.Out4 address]	Communication scanner, value of write word 4

**NOTE:** These parameters can be configured by the DTM-based software.

- **Assembly 101: Native Drive Input**

The following table provides the input assembly mapping:

Word number	Definition
0	Status word
1	Actual Speed (rpm)
3	Scanner write word 3
4	Scanner write word 4

The following table describes the ATV600 assignment:

Word number	Code	Description
1	[Scan.IN1 address]	Communication scanner, value of read word 1 (default value: ETA, Status word)
2	[Scan.IN2 address]	Communication scanner, value of read word 2 (default value: RFRD, Actual speed)
3	[Scan.IN3 address]	Communication scanner, value of read word 3
4	[Scan.IN4 address]	Communication scanner, value of read word 4

**NOTE:** These parameters can be configured by the DTM-based software.

## Control According to ODVA AC Drive Profile

The ODVA AC drive profile is activated when one of the following assemblies is selected:

- 20: Basic speed control output, size 2 words / 4 bytes
- 21: Extended speed control output, size 2 words / 4 bytes
- 70: Basic speed control input, size 2 words / 4 bytes
- 71: Extended speed control input, size 2 words / 4 bytes

The DeviceNet fieldbus module translates the commands, behavior, and display information from of ODVA profile (on the network) to the CiA402 profile (in the drive).

### CIP Basic Speed Control (Assemblies 20 and 70)

#### • Assembly 20: CIP basic speed control output

The following table describes the assembly mapping:

Word Number	Definition
0	CIP basic command word
1	Speed reference (rpm)

The following table describes the CIP basic command word:

Bit 7	Bit 6	Bit 5	Bit 4	Bit 3	Bit 2	Bit 1	Bit 0
Not used	Not used	Not used	Not used	Not used	Fault reset <sup>(1)</sup> 0: No command 1: Fault reset	Not used	Run forward <sup>(2)</sup> 0: Stop 1: Run
<sup>(1)</sup> Active on rising edge							
<sup>(2)</sup> Active on level							

Bit 15	Bit 14	Bit 13	Bit 12	Bit 11	Bit 10	Bit 9	Bit 8
Not used	Not used	Not used	Not used	Not used	Not used	Not used	Not used

#### • Assembly 70: CIP basic speed control input

The following table describes the assembly mapping:

Word Number	Definition
0	CIP basic status word
1	Actual speed (rpm)

The following table describes the CIP basic command word:

Bit 7	Bit 6	Bit 5	Bit 4	Bit 3	Bit 2	Bit 1	Bit 0
Not used	Not used	Not used	Not used	Not used	Running 0: Stopped 1: Running	Not used	Operating state fault 0: Inactive 1: Active

Bit 15	Bit 14	Bit 13	Bit 12	Bit 11	Bit 10	Bit 9	Bit 8
Not used	Not used	Not used	Not used	Not used	Not used	Not used	Not used

### CIP Extended Speed Control (Assemblies 21 and 71)

**NOTE:** `NetRef` and `NetCtrl` objects must be set by explicit messaging to control the drive by network.

#### • Assembly 21: CIP extended speed control output

The following table describes the assembly mapping:

Word Number	Definition
0	CIP extended command word
1	Speed reference (rpm)

The following table describes the CIP extended command word:

Bit 7	Bit 6	Bit 5	Bit 4	Bit 3	Bit 2	Bit 1	Bit 0
Not used	Network setpoint 0: Setpoint by terminal 1: Setpoint by network	Network command 0: Setpoint by terminal 1: Setpoint by network	Not used	Not used	Fault reset <sup>(1)</sup> 0: No command 1: Fault reset	Run forward / reverse 00: Quick stop 01: Run forward 10: Run reverse 11: No action	
<sup>(1)</sup> Active on rising edge							

Bit 15	Bit 14	Bit 13	Bit 12	Bit 11	Bit 10	Bit 9	Bit 8
Not used	Not used	Not used	Not used	Not used	Not used	Not used	Not used

● **Assembly 71: CIP extended speed control input**

The following table describes the assembly mapping:

Word Number	Definition
0	CIP extended status word
1	Actual speed (rpm)

The following table describes the CIP extended status word:

Bit 7	Bit 6	Bit 5	Bit 4	Bit 3	Bit 2	Bit 1	Bit 0
At reference 0: Reference not reached 1: Reference reached	Setpoint from network 0: Setpoint from terminal 1: Setpoint from network	Command from network 0: Setpoint from terminal 1: Setpoint from network	Ready 0: Not ready 1: Ready	Run forward / reverse 00: Stopped 01: Running forward 10: Running reverse 11: Not used	Warning 0: No Warning 1: Warning	Operating state fault 0: Inactive 1: Active	

Bit 15	Bit 14	Bit 13	Bit 12	Bit 11	Bit 10	Bit 9	Bit 8
Not used	Not used	Not used	Not used	Not used	Bit 8 to 10 are used for the drive state 000: Not used 001: Startup 010: Not ready 011: Ready 100: Enabled 101: Stopping 110: Fault stop 111: Operating state fault		

**Network Setpoint and Network Address Management**

The assembly 21 uses the command and reference frequency switching functions of the drive.

To operate correctly, command settings of the drive must be as follows or a **[Fieldbus Error] E P F 2** is triggered.

Menu	Parameter	Settings
[Complete settings] C S t -/[Command and Reference] C r P -	[Control Mode] C H C F [Ref Freq 1 Config] F r 1 [Ref Freq 2 Config] F r 2 [Cmd Channel 1] C d 1 [Cmd Channel 2] C d 2 [Command Switching] C C 5 [Ref Freq 2 switching] r F C	[Separate] S E P [Ref. Freq-Com. Module] n E t [AI1] A , 1 or [AI2] A , 2 [Com. Module] n E t [Terminals] t E r [C312] C 3 1 2 [C313] C 3 1 3

## Messaging (Explicit Exchanges)

### Introduction

Parameters of the drive can be accessed by R/W as CIP objects.

### Altivar Parameters Path

The drive parameters are grouped in classes:

- Each application class has only one instance.
- Each instance groups 200 parameter.
- Each attribute in an instance relates to a parameter.

The first parameter registered in the first application class (class code: 70 hex = 112) has the logical address 3000.

#### Calculation of the DeviceNet path:

Class code =  $((ADL-3000)/200 + 70 \text{ hex})$

Attribute ID =  $(ADL \text{ modulo } 200) + 1$

Instance = 1

with ADL = Parameter number (logical address of the parameter)

#### Example

The following table describes the examples of logical addresses:

Logical Address	Hexadecimal	Decimal
3000	70 hex / 01 hex / 01 hex	112/1/1
3100	70 hex / 01 hex / 65 hex	112/1/101
3200	71 hex / 01 hex / 01 hex	113/1/1
64318	A2 hex / 01 hex / 77 hex	418/1/119

For details, refer to the communication parameters file.

---

## Section 2.2

### CIP Object

---

#### What Is in This Section?

This section contains the following topics:

Topic	Page
Supported Classes	24
Identity Object	25
Message Router Object	27
DeviceNet Object	28
Assembly Object	29
Connection Object	33
Motor Data Object	38
Control Supervisor Object	39
AC/DC Drive Object	41
Acknowledge Handler Object	43
Application Objects	44
DeviceNet Interface Object	46

## Supported Classes

### Description

The table provides the list of the supported classes

Object Class	Class ID		Need for ODVA Conformance	No. of Instances	Effect on Behavior	Interface
	Hex.	Dec.				
Identity	01 hex	1	Required	1	Supports the reset service	Message router
Message router	02 hex	2	Optional	1	–	Explicit message connection
DeviceNet	03 hex	3	Required	1	Configures node attributes	Message router
Assembly	04 hex	4	Required	13	Defines I/O data format	Message router, assembly, or parameter object
DeviceNet connection	05 hex	5	Required	3	Logical ports into or out of the device	I/O connection or message router
Motor data	28 hex	40	Required	1	Defines motor data for the motor connected to this device	Message router or parameter object
Control supervisor	29 hex	41	Required	1	Manages drive functions, operational states, and control	Message router, assembly, or parameter object
AC/DC drive	2A hex	42	Required	1	Provides drive configuration	Message router, assembly, or parameter object
Acknowledge handler	2B hex	43	Optional	1	–	I/O connection or message router
Application	70 hex... A8 hex	112...4 24	Optional	–	Vendor-specific object	Message router or parameter object
DeviceNet interface	64 hex	100	Optional	1	–	–



## Identity Object

### Introduction

The identity object provides identification and status information about the drive.

### Class Code

The table provides the supported class code for identity object:

Hexadecimal	Decimal
01 hex	1

### Class Attributes

The table provides the supported class attributes for identity object:

Attribute ID	Access	Name	Need	Data Type	Value	Details
1	Get	Revision	Opt.	UINT	1	-
2	Get	Max instances	Opt.	UINT	1	1 defined instance

### Instance Attributes

The table provides the supported instance attributes for identity object:

Attribute ID	Access	Name	Need	Data Type	Value	Details
1	Get	Vendor ID	Req.	UINT	243	-
2	Get	Device type	Req.	UINT	02 hex	AC/DC drive profile
3	Get	Product code	Req.	UINT	5	-
4	Get	Revision	Req.	Struct of: USINT USINT	-	Module version <sup>(1)</sup>
5	Get	Status	Req.	WORD	-	See definition in the table below
6	Get	Serial number	Req.	UDINT	-	Serial number of the drive
7	Get	Product name	Req.	Struct of: USINT STRING	-	11 (product name length) of the drive
8	Get	State (see State Diagram for the Identity Object <i>(see page 26)</i> )	Opt.	USINT	-	0: Non-existent 1: Device self-testing 2: Standby 3: Operational 4: Major recoverable detected error 5: Major unrecoverable detected error
10	Get/Set	Heartbeat interval <sup>(2)</sup>	Opt.	USINT	0...255	Interval in seconds between 2 heartbeat messages 0: No message

<sup>(1)</sup> Mapped in a word: MSB minor revision (second USINT), LSB major revision (first USINT).  
Example: 517 = 0205 hex means revision V5.2.

<sup>(2)</sup> The heartbeat message broadcasts the current state of the device.

### Attribute 5–Status

The table provides the supported attribute 5-status for identity object:

Bit	Definition
0	Owned by master (predefined master/slave connection)
2	Configured (not used)
8	Minor recoverable detected error (not used)

Bit	Definition
9	Minor unrecoverable detected error (not used)
10	Major recoverable detected error
11	Major unrecoverable detected error
Others	Reserved 0 (reset to 0)

**Class Service**

The table provides the supported class service for identity object:

Service Code	Service Name	Need	Description
0E hex	Get_Attribute_Single	Req.	Read an attribute

**Instance Service**

The table provides the supported instance service for identity object:

Service Code	Service Name	Need	Description
0E hex	Get_Attribute_Single	Req.	Read an attribute
10 hex	Set_Attribute_Single	(1)	Write an attribute
05 hex	Reset	Req.	Reset DeviceNet module

(1) Required if the heartbeat interval must be defined.

**State Diagram for the Identity Object**

The following figure shows the state diagram for the identity object:

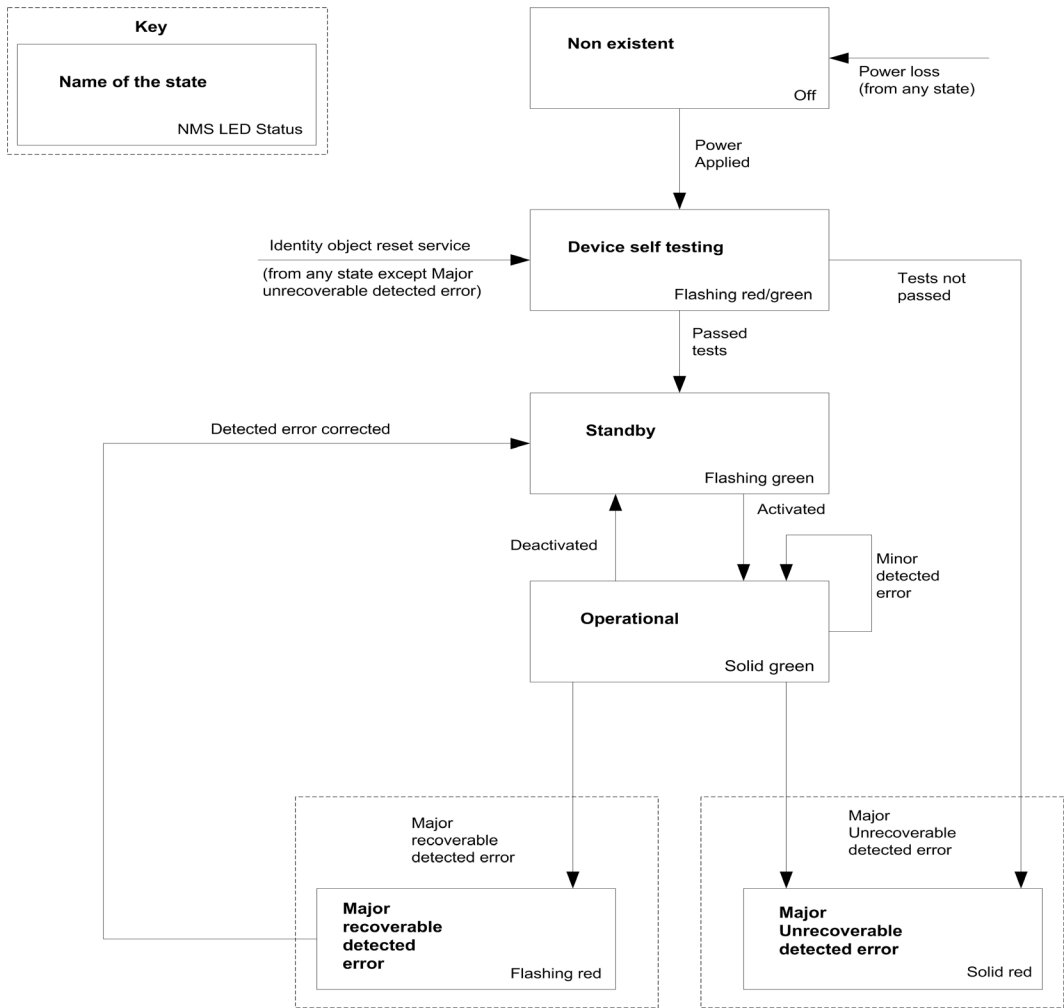

## Message Router Object

### Introduction

This is an element through which all the explicit message objects pass in order to be directed towards the objects they are truly destined to.

### Class Code

The table provides the supported class code for message router object:

Hexadecimal	Decimal
02 hex	2

### Class Attributes

The table provides the supported class attributes for message router object:

Attribute ID	Access	Name	Need	Data Type	Value	Details
1	Get	Revision	Opt.	UINT	1	-
2	Get	Max instances	Opt.	UINT	1	1 defined instance

### Instance Attributes

The table provides the supported instance attributes for message router object:

Attribute ID	Access	Name	Need	Data Type	Value	Details
2	Get	Number available	Opt.	UINT	1	Maximum number of simultaneous connections
3	Get	Number active	Opt.	UINT	1	Number of active connections
4	Get	Active connections	Opt.	UINT	1	List of active connections (referred to with their respective connection instance ID)

### Class Service

The table provides the supported class service for message router object:

Service Code	Service Name	Need	Description
0E hex	Get_Attribute_Single	Req.	Read an attribute

### Instance Service

The table provides the supported instance service for message router object:

Service Code	Service Name	Need	Description
0E hex	Get_Attribute_Single	Req.	Read an attribute

## DeviceNet Object

### Introduction

The DeviceNet object provides the status and configuration of a DeviceNet node.

### Class Code

The table provides the supported class code for DeviceNet object:

Hexadecimal	Decimal
03 hex	3

### Class Attributes

The table provides the supported class attributes for DeviceNet object:

Attribute ID	Access	Name	Need	Data Type	Value	Details
1	Get	Revision	Opt.	UINT	2	-
2	Get	Max Instances	Opt.	UINT	1	1 defined instance

### Instance Attributes

The table provides the supported instance attributes for DeviceNet object:

Attribute ID	Access	Name	Need	Data Type	Value	Details
1	Get/Set	Node address	Req.	USINT	0...63	Option board address
2	Get/Set	Data rate	Opt.	USINT	0...2	0 = 125 kbit/s 1 = 250 kbit/s 2 = 500 kbit/s
3	Get/Set	BOI (Bus Off Interrupt)	Opt.	BOOL	-	Upon BusOff event: 0: CAN component remains in BusOff 1: Component is reset and communication resumes
4	Get/Set	BusOff counter	Opt.	USINT	0...255	Number of occurrences of BusOff state. Set access is used to reset this counter.
5	Get	Allocation information	Opt.	Byte USINT	- 0...63	Allocation choice Master address (255 not allocated)

### Class Service

The table provides the supported class service for DeviceNet object:

Service Code	Service Name	Need	Description
0E hex	Get_Attribute_Single	Req.	Read an attribute

### Instance Service

The table provides the supported instance service for DeviceNet object:

Service Code	Service Name	Need	Description
0E hex	Get_Attribute_Single	Opt.	Read an attribute
10 hex	Set_Attribute_Single	Opt.	Write an attribute
4B hex	Allocate Master/Slave Connection Set	Opt.	Allocation connection master/slave
4C hex	Release Master/Slave Connection Set	Opt.	Release connection master/slave

## Assembly Object

### Introduction

The assembly object binds together the attributes of multiple objects so that information to or from each object can be communicated over a single connection.

Assembly objects are static.

The assemblies in use can be modified through the parameter access of the network configuration tool (RSNetWorx).

The drive needs a power off to take into account a new assembly assignment.

### Class Code

The table provides the supported class code for assembly object:

Hexadecimal	Decimal
04 hex	4

### Class Attribute

The table provides the supported class attribute for assembly object:

Attribute ID	Access	Name	Need	Data Type	Value	Details
1	Get	Revision	Opt.	UINT	2	-
2	Get	Max instance	Opt.	UINT	101	-

### Instances Supported

The table provides the instances supported for assembly object:

Instance	Name	Data Size
20	ODVA Basic speed control output	4 bytes
21	ODVA Extended speed control output	4 bytes
70	ODVA Basic speed control input	4 bytes
71	ODVA Extended speed control input	4 bytes
100	Communication scanner output	8 bytes
101	Communication scanner input	8 bytes

### Instance Attributes

The table provides supported instance attributes for assembly object:

Attribute ID	Access	Name	Need	Data Type	Value	Details
3	Get/Set <sup>(1)</sup>	Data	Req	-	-	-

<sup>(1)</sup> Set access is restricted to output instances only (instances 20, 21, and 100).

### Class Service

The table provides supported class services for assembly object:

Service Code	Service Name	Need	Description
0E hex	Get_Attribute_Single	Req.	Read an attribute

### Instance Service

The table provides supported instance service for assembly object:

Service Code	Service Name	Need	Description
0E hex	Get_Attribute_Single	Req.	Read an attribute
10 hex	Set_Attribute_Single	Opt.	Write an attribute

**Output Assembly 100**

Bytes	Description
0, 1	First scanner out parameter $\alpha C R 1$
2, 3	Second scanner out parameter $\alpha C R 2$
4, 5	Third scanner out parameter $\alpha C R 3$
6, 7	Fourth scanner out parameter $\alpha C R 4$

**Input Assembly 101**

Bytes	Description
0, 1	First scanner in parameter $\alpha P R 1$
2, 3	Second scanner in parameter $\alpha P R 2$
4, 5	Third scanner in parameter $\alpha P R 3$
6, 7	Fourth scanner in parameter $\alpha P R 4$

**NOTE:**

- For the assignment of the scanner parameters by the display terminal, see Operating Modes.
- To display the scanner parameters by the display terminal, see Diagnostics and Troubleshooting.
- For the assignment and display of the scanner parameters by the network configuration software (RSNetWorx...), see Fieldbus Integration Tutorial (*see page 94*).

**Output Assembly 20**

- Byte 0:

Bit 7	Bit 6	Bit 5	Bit 4	Bit 3	Bit 2	Bit 1	Bit 0
Not used	Not used	Not used	Not used	Not used	Error reset (active at 1)	Not used	Run forward 0 = Stop 1 = Run

- Byte 1:

Bit 15	Bit 14	Bit 13	Bit 12	Bit 11	Bit 10	Bit 9	Bit 8
Not used	Not used	Not used	Not used	Not used	Not used	Not used	Not used

- Byte 2 and 3: Speed setpoint (RPM)

**NOTE:**

- Stop mode is configured by the parameter **[Type of stop] 5 E E :**
  - Drive display terminal menu **[Complete settings] C 5 E -/[Command and Reference] C r P -/[Start/Stop] 5 E 5 E -**, submenu **[Stop configuration] 5 E E -**,
  - Path 99 hex/01/02.
- Output assembly 20 controls the drive if the parameter `NetCtrl` is set to 1 (attribute 5 of control supervisor object; path 29 hex/01/05, the default setting is 0).
- Output assembly 20 gives the speed set point to drive if the parameter `NetRef` is set to 1 (attribute 4 of AC/DC drive object, path 2A hex/01/04, the default setting is 0).

In default setting, output assembly 20 controls the drive but the speed setpoint is controlled via terminals (AI1 or AI2).

The default setting applies each time the connection is closed (Power on of the drive, DeviceNet disconnected from the card).

**Input Assembly 70**

- Byte 0:

Bit 7	Bit 6	Bit 5	Bit 4	Bit 3	Bit 2	Bit 1	Bit 0
Not used	Not used	Not used	Not used	Not used	Running 0 = Stopped 1 = Running	Not used	Detected error 0 = No error detected 1 = error detected

- Byte 1:

Bit 15	Bit 14	Bit 13	Bit 12	Bit 11	Bit 10	Bit 9	Bit 8
Not used	Not used	Not used	Not used	Not used	Not used	Not used	Not used

- Bytes 2 and 3: Actual speed (RPM)

### Output Assembly 21

- Byte 0:

Bit 7	Bit 6	Bit 5	Bit 4	Bit 3	Bit 2	Bit 1	Bit 0
Not used	Network reference	Network control	Not used	Not used	Detected error reset (active at 1)	Run reverse	Run forward
	0	0				0	0
	Control and reference by terminals					Stop	
	0	1				0	1
	Control by network reference by terminals					Run forward	
	1	0				1	0
	Control by terminal reference by network					Run reverse	
	1	1				1	1
Control and reference by network		No action					

- Byte 1:

Bit 15	Bit 14	Bit 13	Bit 12	Bit 11	Bit 10	Bit 9	Bit 8
Not used	Not used	Not used	Not used	Not used	Not used	Not used	Not used

- Bytes 2 and 3: Speed setpoint (RPM)

**NOTE:** Stop mode is configured by the parameter **[Type of stop] 5 L L**:

- Drive display terminal menu **[Application function] F u n -**, submenu **[Stop Configuration] 5 L L -**,
- Path 99 hex/01/02.

### Input Assembly 71

- Byte 0:

Bit 7	Bit 6	Bit 5	Bit 4	Bit 3	Bit 2	Bit 1	Bit 0
At reference	Reference from network	Control from network	Ready	Running reverse	Running forward	Warning	Detected error
0 Speed reference not reached	0	0	0 Not ready	0	0	0 No warning	0 No error detected
	Control and reference by terminals			Stopped			
	0	1	1 Ready	0	1	1 Warning	1 Warning
Control by network reference by terminals		Running forward					
1 Speed reference reached	1	0		1	0		
	Control by terminal references by network			Running reverse			
	1	1		1	1		
	Control and reference by network			Stopped			

- Byte 1:

Bit 15	Bit 14	Bit 13	Bit 12	Bit 11	Bit 10	Bit 9	Bit 8
Drive state (see Control Supervisor State Transition Diagram <a href="#">(see page 40)</a> . (0 = Vendor Specific, 1 = Startup, 2 = Not_Ready, 3 = Ready, 4 = Enabled, 5 = Stopping, 6 = Fault_Stop, 7 = Detected error)							

- Bytes 2 and 3: Actual speed (RPM)



## Connection Object

### Class Code

The table provides the supported class code for connection object:

Hexadecimal	Decimal
05 hex	5

### Class Attributes

The table provides the supported class attributes for connection object:

Attribute ID	Access	Name	Need	Data Type	Value	Details
1	Get	Revision	Opt.	UINT	1	-
2	Get	Max instances	Opt.	UINT	4	5 defined instances

### Attributes of Instance 1 - Explicit Message Instance

The table provides the supported explicit message instance for connection object:

Attribute ID	Access	Name	Need	Data Type	Value	Details
1	Get	State	Req.	USINT	-	0: Non-existent 3: Established 5: Deferred delete
2	Get	Instance_type	Req.	USINT	0	Explicit message
3	Get	TransportClass_trigger	Req.	BYTE	83 hex	Class 3 server
4	Get	Produced_connection_id	Req.	UINT	10xxxxxx011	xxxxxx = node address
5	Get	Consumed_connection_id	Req.	UINT	10xxxxxx100	xxxxxx = node address
6	Get	Initial_comm_characteristics	Req.	BYTE	21 hex	Explicit messaging via group 2
7	Get	Produced_connection_size	Req.	UINT	36	Produced data maximum size (in bytes)
8	Get	Consumed_connection_size	Req.	UINT	36	Consumed data maximum size (in bytes)
9	Get/Set	Expected_packet_rate	Req.	UINT	2500	2.5 sec. (TimeOut)
12	Get/Set	Watchdog_timeout_action	Req.	USINT	1 or 3	1: Auto-Delete 3: Deferred delete (Default)
13	Get	Produced connection path length	Req.	UINT	0	Length of attribute 14 data
14	Get	Produced connection path	Req.	Array of UINT	Null	Empty
15	Get	Consumed connection path length	Req.	UINT	0	Length of attribute 16 data
16	Get	Consumed connection path	Req.	Array of UINT	Null	Empty

Refer to DeviceNet specification for more information

**Predefined Master/slave Explicit Messaging State Transition Diagram**

The following figure shows the state diagram for master/slave transition diagram:

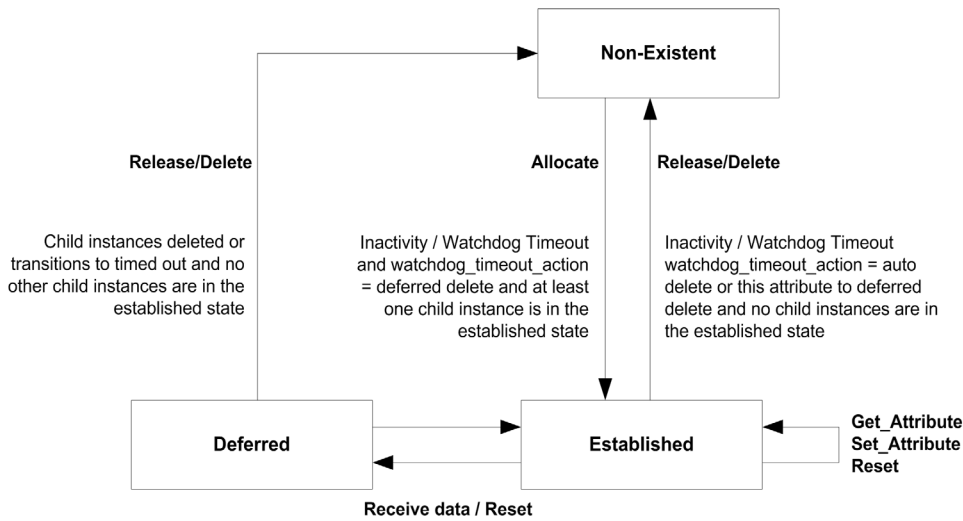

**Attributes of Instance 2 - Polled I/O Message Instance**

The table provides the supported polled I/O message instance for connection objects:

Attribute ID	Access	Name	Need	Data Type	Value	Details
1	Get	State	Req.	USINT	-	0: Non-existent 1: Configuring 3: Established 4: TimeOut
2	Get	Instance_type	Req.	USINT	1	I/O message
3	Get	TransportClass_trigger	Req.	BYTE	83 hex	Class 3 server
4	Get	Produced_connection_id	Req.	UINT	01111xxxxxx	xxxxxx = node address
5	Get	Consumed_connection_id	Req.	UINT	10xxxxxx101	xxxxxx = node address
6	Get	Initial_comm_characteristics	Req.	BYTE	01 hex	Group 1 / group 2
7	Get	Produced_connection_size	Req.	UINT	4, 6, or 8	Size of data produced
8	Get	Consumed_connection_size	Req.	UINT	4, 6, or 8	Size of data consumed
9	Get/Set	Expected_packet_rate	Req.	UINT	-	Exchange frequency (ms)
12	Get/Set	Watchdog_timeout_action	Req.	USINT	0, 1, or 2 (2)	0: Transition to TimeOut 1: Auto-Delete 2: Auto-Reset
13	Get	Produced_connection_path length	Req.	UINT	8	Default: 8 bytes

(1) Assembly assignment should not be modified in a running application. If you set any one of the values displayed in the value column, it is saved in EEPROM and then used at each power-up. Any other value can not be saved.  
 (2) 0 and 1: when the drive is disconnected from the network a DeviceNet detected error occurs. In factoring settings the DeviceNet detected error triggers a [Fieldbus Com Interruption]  $C_n F$  and a freewheel stop.  
 2: The DeviceNet detected error is automatically cleared (drive immediately restarts when RUN command is applied).

Attribute ID	Access	Name	Need	Data Type	Value	Details
14	Get/Set <sup>(1)</sup>	Produced_connection_path	Req.	Array of UINT	20-04-24-46-30-03 20-04-24-47-30-03 20-04-24-48-30-03 20-04-24-49-30-03 20-04-24-65-30-03 20-04-24-68-30-03 20-04-24-69-30-03	Input assembly (Default: Instance 101, 20-04-24-65-30-03)
15	Get	Consumed_connection_path length	Req.	UINT	8	Default: 8 bytes
16	Get/Set <sup>(1)</sup>	Consumed_connection_path	Req.	Array of UINT	20-04-24-15-30-03 20-04-24-16-30-03 20-04-24-64-30-03 20-04-24-67-30-03	Output assembly (Default: Instance 100, 20-04-24-64-30-03)
17	Get	Production_inhibit_time	Cond.	UINT	0	Minimum time between 2 data productions undefined

<sup>(1)</sup> Assembly assignment should not be modified in a running application. If you set any one of the values displayed in the **value** column, it is saved in EEPROM and then used at each power-up. Any other value can not be saved.

<sup>(2)</sup> 0 and 1: when the drive is disconnected from the network a DeviceNet detected error occurs. In factoring settings the DeviceNet detected error triggers a **[Fieldbus Com Interruption] C n F** and a freewheel stop.

2: The DeviceNet detected error is automatically cleared (drive immediately restarts when RUN command is applied).

### Attributes of Instance 4 - Change of State/Cyclic Message Instance

The table provides the supported change of state/cycle message instance for connection object:

Attribute ID	Access	Name	Need	Data Type	Value	Details
1	Get	State	Req.	USINT	-	0: Non-existent 1: Configuring 3: Established 4: Time-Out
2	Get	Instance_type	Req.	USINT	1	I/O message
3	Get	TransportClass_trigger	Req.	BYTE	X2 hex	Class 2 client Cos:12 hex - Cyclic: 02 hex
4	Get	Produced_connection_id	Req.	UINT	01101xxxxx	xxxxxx = node address
5	Get	Consumed_connection_id	Req.	UINT	10xxxxxx101	xxxxxx = node address
6	Get	Initial_comm_characteristics	Req.	BYTE	01 hex	Group 1 / group 2
7	Get	Produced_connection_size	Req.	UINT	4, 6, or 8	Size of data produced
8	Get	Consumed_connection_size	Req.	UINT	0	Size of data consumed
9	Get/Set	Expected_packet_rate	Req.	UINT	-	Exchange frequency (ms)
12	Get/Set	Watchdog_timeout_action	Req.	USINT	0, 1, or 2 <sup>(2)</sup>	0: Transition to Time-Out 1: Auto-Delete 2: Auto-Reset
13	Get	Produced_connection_path length	Req.	UINT	8	Default: 8 bytes

<sup>(1)</sup> Assembly assignment should not be modified in a running application. If you set any one of the values displayed in the **value** column, it is saved in EEPROM and then used at each powerup. Any other value can not be saved..

<sup>(2)</sup> To ensure a DeviceNet detected error (and by default **[Fieldbus Com Interruption] C n F** in case of time-out, configure polled I/O.

Attribute ID	Access	Name	Need	Data Type	Value	Details
14	Get/Set <sup>(1)</sup>	Produced_connection_path	Req.	Array of UINT	20-04-24-46-30-03 20-04-24-47-30-03 20-04-24-48-30-03 20-04-24-49-30-03 20-04-24-65-30-03 20-04-24-68-30-03 20-04-24-68-30-03	Input assembly (Default: Instance 101, 20-04-24-65-30-03)
15	Get	Consumed_connection_path length	Req.	UINT	8	Default: 8 bytes
16	Get/Set <sup>(1)</sup>	Consumed_connection_path	Req.	Array of UNIT	20-2B-24-01-30-03	Output assembly: The first and only one instance of the acknowledge handler object (Class ID 2B hex)
17	Get	Production_inhibit_time	Cond.	UINT	0	Minimum time between 2 data productions undefined

<sup>(1)</sup> Assembly assignment should not be modified in a running application. If you set any one of the values displayed in the **value** column, it is saved in EEPROM and then used at each powerup. Any other value can not be saved..  
<sup>(2)</sup> To ensure a DeviceNet detected error (and by default **[Fieldbus Com Interrupt] CNF** in case of time-out, configure polled I/O.

**Predefined Master/slave I/O Connection State Transition Diagram**

The following figure shows the state transition diagram for predefined master/slave I/O connection:

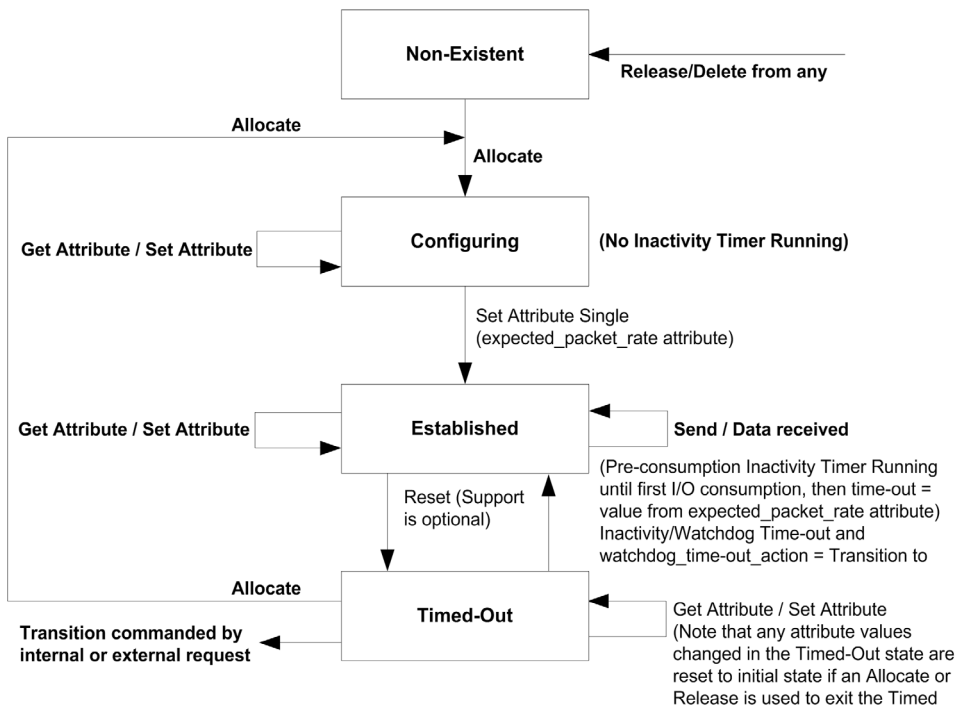

**NOTE:** The allocate and release services send the connection instance back to initial state. All object attributes are reset to their default values.

### Class Service

The table provides the supported instance service for connection object:

Service Code	Service Name	Need	Description
0E hex	Get_Attribute_Single	Req.	Read an attribute

### Instance Service

The table provides the supported instance service for connection object:

Service Code	Service Name	Need	Description
0E hex	Get_Attribute_Single	Req.	Read an attribute
10 hex	Set_Attribute_Single	Opt.	Write an attribute
05 hex	Reset	Opt.	Reset Inactivity/Watchdog timer

## Motor Data Object

### Introduction

The motor data object acts as a motor parameter database.

### Class Code

The table provides the supported class code for motor data object:

Hexadecimal	Decimal
28 hex	40

### Class Attributes

The table provides the supported class attributes for motor data object:

Attribute ID	Access	Name	Need	Data Type	Value	Details
1	Get	Revision	Opt.	UINT	1	-
2	Get	Max instance	Opt.	UINT	1	-
6	Get	Max ID number of class attribute	Opt.	UINT	7	-
7	Get	Max ID number of instance attribute	Opt.	UINT	15	-

### Instance Attributes

The table provides the supported instance attributes for motor data object:

Attribute ID	Access	Name	Need	Data Type	Value	Details
3	Get/Set	MotorType	Req.	USINT	7	6 = Wound rotor induction motor 7 = Squirrel cage induction motor
6	Get/Set	RatedCurrent	Req.	UINT	Depends on the drive rating	<b>[Nom Motor Current]</b> <i>n I r</i>
7	Get/Set	RatedVoltage	Req.	UINT	Depends on the drive rating	<b>[Nom Motor Voltage]</b> <i>u n 5</i>
9	Get/Set	RatedFreq	Opt.	UINT	50/60	<b>[Nom Motor Frequency]</b> <i>F r 5</i>
15	Get/Set	BaseSpeed	Opt.	UINT	Depends on the drive rating	<b>[Nominal Motor Speed]</b> <i>n 5 P</i>

### Class Service

The table provides the supported class service for motor data object:

Service Code	Service Name	Need	Description
0E hex	Get_Attribute_Single	Req.	Read an attribute

### Instance Service

The table provides the supported instance service for motor data object:

Service Code	Service Name	Need	Description
0E hex	Get_Attribute_Single	Req.	Read an attribute
10 hex	Set_Attribute_Single	Opt.	Write an attribute

## Control Supervisor Object

### Introduction

The control supervisor object models the functions for managing all devices within the hierarchy of motor control devices.

### Class Code

The table provides the supported class code for control supervision object:

Hexadecimal	Decimal
29 hex	41

### Class Attributes

The table provides the supported class attribute for control supervision object:

Attribute ID	Access	Name	Need	Data Type	Value	Details
1	Get	Revision	Opt.	UINT	1	-
2	Get	Max instance	Opt.	UINT	1	-
6	Get	Max ID number of class attribute	Opt.	UINT	7	-
7	Get	Max ID number of instance attribute	Opt.	UINT	17	-

### Instance Attributes

The table provides the supported instance attributes for control supervision object:

Attribute ID	Access	Name	Need	Data Type	Details
3	Get/Set	Run Fwd	Req.	BOOL	On an edge (0 [gs56]1)
4	Get/Set	Run Rev	Opt.	BOOL	On an edge (0 [gs56]1)
5	Get/Set	NetCtrl	Opt.	BOOL	0: Local control (Channel 1) 1: Network control (default)
6	Get	State	Opt.	USINT	0 = Vendor specific, 1 = Start-up 2 = Not_Ready 3 = Ready 4 = Enabled 5 = Stopping 6 = Fault_Stop 7 = error detected
7	Get	Running Fwd	Req.	BOOL	-
8	Get	Running Rev	Opt.	BOOL	-
9	Get	Ready	Opt.	BOOL	-
10	Get	Faulted	Req.	BOOL	-
12	Get/Set	FaultRst	Req.	BOOL	Detected error reset (0 [gs56]1)
13	Get	FaultCode	Opt.	UINT	Refer to the communication parameter manual: DSP402 detected error code <i>E r r d</i>
15	Get	CtrlFromNet	Opt.	BOOL	0 = Local control; 1 = network control
16	Get/Set	DNFaultMode	Opt.	USINT	Action on loss of DeviceNet command: 0 = DeviceNet detected error; 1 = Ignored
17	Get/Set	ForceFault/Trip	Opt.	BOOL	Force a DeviceNet detected error (0 [gs56]1)

**Class Service**

The table provides the supported class service for control supervision object:

Service Code	Service Name	Need	Description
0E hex	Get_Attribute_Single	Req.	Read an attribute

**Instance Service**

The table provides the supported instance service for control supervision object:

Service Code	Service Name	Need	Description
0E hex	Get_Attribute_Single	Req.	Read an attribute
10 hex	Set_Attribute_Single	Req.	Write an attribute
05 hex	Reset	Req.	Drive reset

**Control Supervisor State Transition Diagram**

The following figure shows the state transaction diagram for control supervision object:

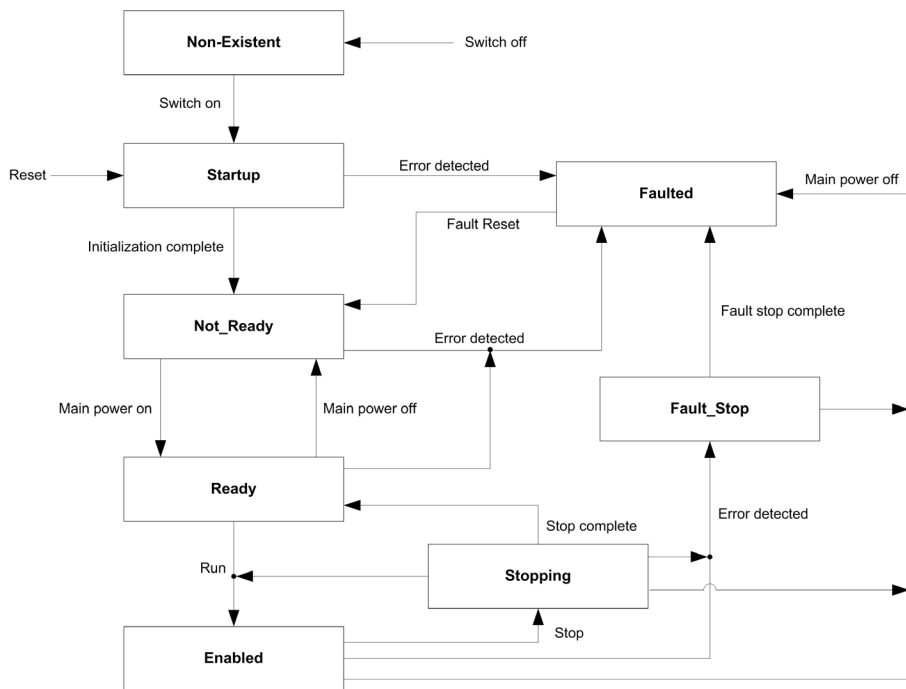



## AC/DC Drive Object

### Introduction

The AC/DC drive object models the functions (such as torque control and speed ramp) that are specific to drives.

### Class Code

The table provides the supported class code for AC/DC drive object:

Hexadecimal	Decimal
2A hex	42

### Class Attributes

The table provides the supported class attributes for AC/DC drive object:

Attribute ID	Access	Name	Need	Data Type	Value	Details
1	Get	Revision	Opt.	UINT	1	-
2	Get	Max instance	Opt.	UINT	1	-
6	Get	Max ID number of class attribute	Opt.	UINT	7	-
7	Get	Max ID number of instance attribute	Opt.	UINT	21	-

### Instance Attributes

The table provides the supported instance attributes for AC/DC drive object:

Attribute ID	Access	Name	Need	Data Type	Details
3	Get	AtReference	Opt.	BOOL	-
4	Get/Set	NetRef	Req.	BOOL	0: Local speed setpoint 1: Speed setpoint via the network
6	Get/Set	Drive mode	Req.	USINT	1: Open loop
7	Get	SpeedActual	Req.	INT	[Motor Frequency] $r F r$
8	Get/Set	SpeedRef	Req.	INT	[Ref Frequency] $L F r$
9	Get	CurrentActual	Opt.	INT	[Motor Current] $L L r$
10	Get/Set	CurrentLimit	Opt.	INT	[Current limitation] $L L i$
11	Get	TorqueActual	Opt.	INT	[Motor torque] $a t r$
18	Get/Set	AccelTime	Opt.	UINT	[Acceleration] $R L L$
19	Get/Set	DecelTime	Opt.	UINT	[Deceleration] $d E L$
20	Get/Set	LowSpdLimit	Opt.	UINT	Parameter [Low Speed] $L S P$ converted in RPM
21	Get/Set	HighSpdLimit	Opt.	UINT	Parameter [High Speed] $H S P$ converted in RPM

### Class Service

The table provides the supported class service for AC/DC drive object:

Service Code	Service Name	Need	Description
0E hex	Get_Attribute_Single	Req.	Read an attribute

**Instance Service**

The table provides the supported instance service for AC/DC drive object:

Service Code	Service Name	Need	Description
0E hex	Get_Attribute_Single	Req.	Read an attribute
10 hex	Set_Attribute_Single	Opt.	Write an attribute

## Acknowledge Handler Object

### Introduction

The acknowledge handler object directs the acknowledgment of messages received.

### Class Code

The table provides the supported class code for acknowledge handler object:

Hexadecimal	Decimal
2B hex	43

### Class Attributes

The table provides the supported class attributes for acknowledge handler object:

Attribute ID	Access	Name	Need	Data Type	Value	Details
1	Get	Revision	Opt.	UINT	1	-
2	Get	Max instance	Opt.	UINT	1	-

### Instance Attributes

The table provides the supported instance attributes for acknowledge handler object:

Attribute ID	Access	Name	Need	Data Type	Value	Details
1	Get/Set	Acknowledge timer	Req.	UINT	16	Default: 16 ms
2	Get/Set	Retry limit	Req.	USINT	1	-
3	Get	COS producing connection instance	Req.	UINT	4	Assembly

### Class Service

The table provides the supported class service for acknowledge handler object:

Service Code	Service Name	Need	Description
0E hex	Get_Attribute_Single	Req.	Read an attribute

### Instance Service

The table provides the supported instance service for acknowledge handler object:

Service Code	Service Name	Need	Description
0E hex	Get_Attribute_Single	Req.	Read an attribute
10 hex	Set_Attribute_Single	Req.	Write an attribute

## Application Objects

### Class Code

The table provides supported class code for application object:

Hexadecimal	Decimal
70...A8 hex	112...424

The option manages application objects with class codes from 70 hex...C7 hex.

There is one instance of each application object.

Each instance attribute of an application object is mapped on a parameter.

Each class can have up to 200 object attributes (giving access to 200 parameters per class).

In the device, parameters are grouped by functions. Each function has up to 100 parameters. Then, each application object gives access to the parameters of 2 functions.

The links between the class code, the object attribute ID, and the parameter logical address (AdL) are given with following formulas:

- $Class\ code = ((AdL - 3000) / 200) + 70\ hex$
- $Attribute\ ID = (AdL\ modulo\ 200) + 1$
- $AdL = (Class\ code - 70\ hex) * 200 + attribute\ ID - 1 + 3000$

With class codes from 70 hex...C7 hex, you give access to logical address in [3000; 20599]. The other addresses are not accessible.

Example:

Parameter Logical Address	Hexadecimal Path: Class Code / Instance Nb / Attribute ID
3000	70 hex / 01 / 01
3100	70 hex / 01 / 65
3201	71 hex / 01 / 02

### Class Attributes

The table provides the supported class attributes for application object:

Attribute ID	Access	Name	Need	Data Type	Value	Details
1	Get	Revision	Opt.	UINT	1	-
2	Get	Max Instance	Opt.	UINT	1	-
6	Get	Max ID Number of class attribute	Opt.	UINT	7	-
7	Get	Max ID Number of Instances attributes	Opt.	UINT	200	-

### Instance Attributes

The table provides the supported instance attributes for application object:

Attribute ID	Access	Name	Data Type	Value
1	Get/Set	First parameter of the class	UINT/USINT	Value returned by the drive
...	...	...	...	...
X	Get	Last parameter of the class	UINT/USINT	Value returned by the drive

### Class Service

The table provides the supported class service for application object:

Service Code	Service Name	Need	Description
0E hex	Get_Attribute_Single	Req.	Read an attribute

## Instance Services

The table provides the supported instance services for application object:

Service Code	Service Name	Need	Description
0E hex	Get_Attribute_Single	Req.	Read an attribute
10 hex	Set_Attribute_Single	Opt.	Write an attribute

## DeviceNet Interface Object

### Class Code

The table provides the supported class code for DeviceNet interface object:

Hexadecimal	Decimal
64 hex	100

### Class Attributes

The table provides the supported class attributes for DeviceNet interface object:

Attribute ID	Access	Name	Need	Data Type	Value
1	Get	Revision	Opt.	UINT	1
2	Get	Max instance	Opt.	UINT	1
6	Get	Max ID number of class attribute	Opt.	UINT	7
7	Get	Max ID number of instance attribute	Opt.	UINT	12

### Instance Attribute

The table provides the supported instance attribute for DeviceNet interface object:

Attribute ID	Access	Name	Data Type	Details
1	Get/Set	Polled/ COS/Cyclic Instance	USINT	70, 71, 101
2	Get	OB firmware version	USINT	Ex:1003 hex (1.0ie03)
3	Get	OCA1	USINT	Get and set the address of the parameters written using assembly 100
4	Get	OCA2	USINT	-
5	Get	OCA3	USINT	-
6	Get	OCA4	USINT	-
7	Get	OMA1	USINT	Get and set the address of the parameters written using assembly 101
8	Get	OMA2	USINT	-
9	Get	OMA3	USINT	-
10	Get	OMA4	USINT	-
11	Get	Communication fault code	USINT	Give the reason of the communication interruption on the DeviceNet network. Possible values are given in 3.6.1

**NOTE:** Writing the attributes 1 triggers an EEPROM back-up. The option must be restarted to take this information into account.

### Class Service

The table provides the supported class service for DeviceNet interface object:

Service Code	Service Name	Need	Description
0E hex	Get_Attribute_Single	Req.	Read an attribute

### Instance Services

The table provides the supported instance service for DeviceNet interface object:

Service Code	Service Name	Need	Description
0E hex	Get_Attribute_Single	Req.	Read an attribute
10 hex	Set_Attribute_Single	Opt.	Write an attribute

---

# Chapter 3

## Hardware Setup

---

### What Is in This Chapter?

This chapter contains the following topics:

Topic	Page
Hardware Presentation	48
Firmware and Description File	49
Installation of the Module	50
Electrical Installation	51
Cable Routing Practices	52
Accessories Presentation	54

## Hardware Presentation

### DeviceNet Communication Module

The following figure shows the DeviceNet module:



Item	Description	Comment
-	-	Open style connector



---

## Firmware and Description File

### Compatibility

The VW3A3609 fieldbus module, with minimum 1.6IE01 firmware version, are compliant with Altivar process product range.

**NOTE:** Check the firmware version, on right side of the packaging label.

The associated EDS file is named as the following example: *SE\_DN\_ATV600\_0106E.eds*.

The files are available on [www.schneider-electric.com](http://www.schneider-electric.com).

## Installation of the Module

### Before Starting

Check that the module catalog number marked on the label is the same as that on the delivery note corresponding to the purchase order.

Remove the fieldbus module from its packaging and check that it has not been damaged in transit.

### Insertion of the Fieldbus Module

The table provides the procedure for insertion of the DeviceNet option module in the drive:

Step	Action
1	Ensure that the power is off.
2	Locate the fieldbus module slot (A) on the bottom of the control part.
3	Add the corresponding sticker on the LED front panel of the drive.
4	Insert the module.
5	Check that the module is correctly inserted and locked mechanically in the drive.

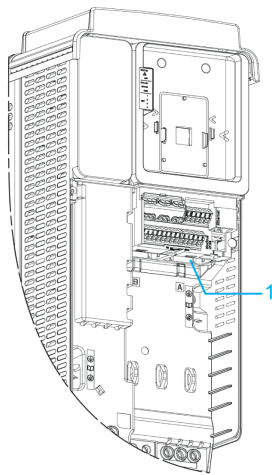

1 Slot A

### Removal of the Fieldbus Module

The table provides the procedure for removal of the DeviceNet option module from the drive:

Step	Action
1	Ensure that the power is off.
2	Press the strip.
3	Remove the module while maintaining the strip pressed,

## Electrical Installation

### Pin Layout

The following figure shows the pin layout of the DeviceNet card connector

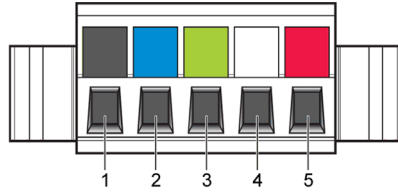

The table provides the pin-out details of the DeviceNet card connector:

Pin	Name	Color
1	GND	Black
2	CAN_L	Blue
3	SHIELD	Bare
4	CAN_H	White
5	V+	Red

## Cable Routing Practices

### General

When wiring drives to a DeviceNet network, follow all wiring practices required by national and local electrical codes. Also observe the following guidelines:

- Avoid areas of high temperature, moisture, vibration, or other mechanical stress.
- Secure the cable where necessary to prevent its weight and the weight of other cables from pulling or twisting the cable.
- Use cable ducts, raceways, or other structures to help the cable. Use these structures for signal wiring paths. They must not contain power wiring.
- Avoid sources of electrical interference that can induce noise into the cable. Use the maximum practicable separation from such sources.

When planning cable routing within a building, follow these guidelines:

Maintain a Minimum Separation of X m from the Following Equipment	
1 m	3 m
Air conditioners and large blowers Elevators and escalators Radios and televisions intercom and security system Fluorescent, incandescent, and neon lighting fixtures	Supply mains and motor power wiring Transformers Generators Alternators

### Guidelines for Cable Segregation and Separation of Circuit

When wiring in electrical equipment rooms or large electrical equipment line-ups, observe the following guidelines for cable segregation and separation of circuits:

- Use metallic conduit for drive wiring. Do not run control network and power wiring in the same conduit.
- Separate non-metallic conduits or cable trays used to carry power wiring from metallic conduit carrying low-level control network wiring by at least 300 mm.
- Separate metallic conduits carrying power wiring or low-level control network wiring by at least 80 mm.
- Cross the metallic conduits and non-metallic conduits at right angles whenever power and control network wiring cross.
- Attenuate conducted emissions from the drive to the line in some installations to prevent interference with telecommunication, radio, and sensitive electronic equipment. Such instances may require attenuating filters. Consult the Altivar catalog for selection and application of these filters.

### Cable Specification

The ODVA standards (Release 2.0) specify 7 types of cables for use in DeviceNet fieldbus.

The table provides the main specifications of the cables. For more information, refer to the ODVA specifications:

Type of Cable	Data Conductor Pair Size	Power Conductor Pair Size	Data Impedance
Thick cable	18 AWG	15 AWG	120 Ω +/- 10%(at 1 MHz)
Thin cable	24 AWG	22 AWG	120 Ω +/- 10%(at 1 MHz)
Flat cable	16 AWG	16 AWG	120 Ω +/- 10%(at 500 KHz)
Cable I	24 AWG	22 AWG	120 Ω +/- 10%(at 1 MHz)
Cable II	18 AWG	15 AWG	120 Ω +/- 10%(at 1 MHz)
Cable IV	18 AWG	16 AWG	120 Ω +/- 10%(at 500 KHz)
Cable V	18 AWG	16 AWG	120 Ω +/- 10%(at 500 KHz)

The maximum permissible length of the network cable depends on the data rate and the type of cable:

Type of Cable	Data Rate		
	125 kbit/s	250 kbit/s	500 kbit/s
Thick cable	500 m (1640 ft.)	250 m (820 ft.)	100 m (328 ft.)
Thin cable	100 m (328 ft.)	100 m (328 ft.)	100 m (328 ft.)
Flat cable	420 m (1378 ft.)	200 m (656 ft.)	75 m (246 ft.)

Type of Cable	Data Rate		
	125 kbit/s	250 kbit/s	500 kbit/s
Cable I	100 m (328 ft.)	100 m (328 ft.)	100 m (328 ft.)
Cable II	500 m (1640 ft.)	250 m (820 ft.)	100 m (328 ft.)
Cable IV	-	-	-
Cable V	420 m (1378 ft.)	200 m (656 ft.)	75 m (246 ft.)

The table provides the maximum length of the drops for all types of cables:

Data Rate	Cumulative Drop	Maximum Drop
125 kbit/s	156 m (516 ft.)	6 m (20 ft.)
250 kbit/s	78 m (256 ft.)	6 m (20 ft.)
500 kbit/s	39 m (128 ft.)	6 m (20 ft.)

## Accessories Presentation

### DeviceNet Accessories for Bus Termination

If the drive is the first or the last device on the DeviceNet fieldbus, a line terminator (121  $\Omega$  resistor) must be wired on the removable DeviceNet connector, between pins 2 and 4 (CAN\_L and CAN\_H).

The table describes the DeviceNet accessories for the different bus termination:

Bus Termination	Accessories	
DeviceNet module VW3A3609	DeviceNet terminating resistor of 120 Ohm, for screw terminal	TCSCAR01NM120

---

# Chapter 4

## Software Setup

---

### What Is in This Chapter?

This chapter contains the following sections:

Section	Topic	Page
4.1	Basic Settings	56
4.2	Additional Settings	61
4.3	Profile	71
4.4	Fieldbus Integration Tutorial	94

# Section 4.1

## Basic Settings

---

### What Is in This Section?

This section contains the following topics:

Topic	Page
Introduction	57
[Address] <i>A d r C</i>	58
[Bit Rate] <i>b d r</i>	59
[Data rate used] <i>b d r u</i>	60



---

## Introduction

### Overview

The parameters are described according to the graphic display terminal. These settings are also possible from commissioning software.

### Access

The parameters are accessible in the **[Communication]** (C o P)/**[Comm Parameters]** (C P P), **[Devicenet]** (d n C -) menu.

**[Address] *A d r C*****About This Parameter**

This parameter defines the address of the drive on the network.

**Access**

This is a read/write parameter.

The parameter number is 6601

**Possible Settings**

The table presents the parameter settings:

Settings	Code	Value	Description
[0] ... [63]	<i>D ... 63</i>	-	<b>Factory settings:</b> 63

**[Bit Rate] b d r****About This Parameter**

This parameter displays the baud rate and the transmission mode currently used by the fieldbus module.

**Access**

This is read/write parameter.

The parameter number is 6603.

**Possible Settings**

The table presents the parameter settings:

Settings	Code	Value	Description
[Auto]	<i>A u t o</i>	-	Baud rate is set automatically
[125 kbd]	<i>1 2 5</i>		Baud rate is set to 125 Kbauds
[250 kbd]	<i>2 5 0</i>		Baud rate is set to 250 kbauds
[500 kbd]	<i>5 0 0</i>		Baud rate is to 500 kbauds
			<b>Factory settings:</b> Auto

**[Data rate used] *b d r u*****About This Parameter**

This parameter displays the data rate and the transmission mode currently used by the fieldbus module.

**Access**

This is read-only parameter.

The parameter number is 6660

**Possible Settings**

The table presents the parameter settings:

Settings	Code	Value	Description
[Auto]	<i>A u t o</i>	-	Data rate is set automatically.
[125 kbd]	<i>1 2 5</i>		Data rate is set to 125 kbauds
[250 kbd]	<i>2 5 0</i>		Data rate is set to 250 kbauds
[500 kbd]	<i>5 0 0</i>		Data rate is set to 500 kbauds

---

## Section 4.2

### Additional Settings

---

#### What Is in This Section?

This section contains the following topics:

Topic	Page
[Conf. Assembly] <i>С</i> <i>1</i> <i>0</i> <i>А</i>	62
[Scan.Out1 address] <i>0</i> <i>С</i> <i>А</i> <i>1</i>	63
[Scan.Out2 address] <i>0</i> <i>С</i> <i>А</i> <i>2</i>	64
[Scan.Out3 address] <i>0</i> <i>С</i> <i>А</i> <i>3</i>	65
[Scan.Out4 address] <i>0</i> <i>С</i> <i>А</i> <i>4</i>	66
[Scan. IN1 address] <i>0</i> <i>П</i> <i>А</i> <i>1</i>	67
[Scan. IN2 address] <i>0</i> <i>П</i> <i>А</i> <i>2</i>	68
[Scan. IN3 address] <i>0</i> <i>П</i> <i>А</i> <i>3</i>	69
[Scan.IN4 address] <i>0</i> <i>П</i> <i>А</i> <i>4</i>	70

**[Conf. Assembly] C I O A****About This Parameter**

This parameter shows the configured Input/Output assembly.

**Access**

This is a read/write parameter.

The parameter number is 6667

**Possible Settings**

The table presents the parameter settings:

Settings	Code	Value	Description
[20/70]	20	-	CIP basic speed control
[21/71]	21		CIP extended speed control
[100/101]	100		Native drive control
[Unconfig.]	unCG		Not configured <b>Factory settings:</b> 21

## [Scan.Out1 address] *o C R I*

### About This Parameter

This parameter displays the address of the first output word.

### Access

This is a read/write parameter.

The parameter number is 15421

### Possible Settings

The table presents the parameter settings:

Settings	Code	Value	Description
[Scan. Out1 address]	<i>o C R I</i>	-	Eligible Modbus address <b>Factory settings:</b> Control word (CMD)
<b>OCAx</b> is used by the assembly set 100,101			

**[Scan.Out2 address]** *□ □ # 2***About This Parameter**

This parameter displays the address of second output word.

**Access**

This is read/write parameter.

The parameter number is 15422.

**Possible Settings**

The table presents the parameter settings:

Settings	Code	Value	Description
[Scan.Out2 address]	<i>□ □ # 2</i>	-	Eligible Modbus address <b>Factory settings:</b> Speed target (LRFD)
OCAx is used by the assembly set 100,101			



## [Scan.Out3 address] □ □ □

### About This Parameter

This parameter displays the address of the third output word.

### Access

This is read/write parameter.

The parameter number is 15423.

### Possible Settings

The table presents the parameter settings:

Settings	Code	Value	Description
[Scan.Out3 address]	□ □ □	-	Eligible Modbus address <b>Factory settings:</b> 0
OCAx is used by the assembly set 100,101			

## [Scan.Out4 address ] *OC R 4*

### About This Parameter

This parameter displays the address of fourth output word.

### Access

This is read/write parameter.

The parameter number is 15424.

### Possible Settings

The table presents the parameter settings:

Settings	Code	Value	Description
[Scan. Out4 address]	<i>OC R 4</i>	-	Eligible Modbus address <b>Factory settings:</b> 0
OCAx is used by the assembly set 100,101			

## [Scan. IN1 address] *□ Π R I*

### About This Parameter

This parameter displays the address of first input word

### Access

This is a read/write parameter.

The parameter number is 15401

### Possible Settings

The table presents the parameter settings:

Settings	Code	Value	Description
[Scan.IN1 address]	<i>□ Π R I</i>	-	Eligible Modbus address <b>Factory settings:</b> Status word (ETA)
<b>OMAx</b> is used by the assembly set 100,101			

## [Scan. IN2 address] $\square \Pi R \mathcal{Z}$

### About This Parameter

This parameter displays the address of second input word.

### Access

This is a read/write parameter.

The parameter number is 15402.

### Possible Settings

The table presents the parameter settings:

Settings	Code	Value	Description
[Scan.IN2 address]	$\square \Pi R \mathcal{Z}$	-	Eligible Modbus address <b>Factory settings:</b> Output speed (RFRD)
<b>OMAx</b> is used by the assembly set 100,101			

## [Scan. IN3 address] 0 1 1 3

### About This Parameter

This parameter displays the address of third input word.

### Access

This is a read/write parameter.

The parameter number is 15403.

### Possible Settings

The table presents the parameter settings:

Settings	Code	Value	Description
[Scan.IN3 address]	0 1 1 3	-	Eligible Modbus address <b>Factory settings:</b> 0
<b>OMAx</b> is used by the assembly set 100,101			

**[Scan.IN4 address] 0 0 0 4****About This Parameter**

This parameter displays the address of fourth input word.

**Access**

This is a read/write parameter.

The parameter number is 15404.

**Possible Settings**

The table presents the parameter settings:

Settings	Code	Value	Description
[Scan.IN4 Address]	0 0 0 4	-	Eligible Modbus address <b>Factory settings:</b> 0
OMAx is used by the assembly set 100,101			

## Section 4.3

### Profile

#### What Is in This Section?

This section contains the following topics:

Topic	Page
Definition of a Profile	72
Functional Profiles Supported by the Drive	73
Functional Description	74
CIA402 Operating State Diagram	75
Description of Operating States	76
Summary	78
Cmd Register <i>C P d</i>	79
Stop Commands	80
Assigning Control Word Bits	81
[CIA402 State Reg] <i>E L R</i>	82
Starting Sequence	83
Sequence for a Drive Powered by the Power Stage Supply	84
Sequence for a Drive with Separate Control Stage	86
Sequence for a Drive with Mains Contactor Control	88
Available Profiles with the VWA3609 Fieldbus Module	90
Control with Communication Scanner	91
Control According to ODVA AC Drive Profile	92

## Definition of a Profile

### Types of Profiles

There are 3 types of profile:

- Communication profiles
- Functional profiles
- Application profiles

### Communication Profile

A communication profile describes the characteristics of the bus or network:

- cables
- connectors
- electrical characteristics
- access protocol
- addressing system
- periodic exchange service
- messaging service
- ...

A communication profile is unique to a type of network (such as Modbus CIP, PROFIBUS DP, and so on) and is used by various different types of device.

### Functional Profile

A functional profile describes the behavior of a type of device:

- Functions
- Parameters (such as name, format, unit, type, and so on.)
- Periodic I/O variables
- State chart
- ...

A functional profile is common to all members of a device family (such as variable speed drives, encoders, I/O modules, displays, and so on).

They can feature common or similar parts. The standardized (IEC 61800-7) functional profiles of variable speed drives are:

- CiA402
- PROFIDRIVE
- CIP

DRIVECOM has been available since 1991.

CiA402 device profile for drives and motion control represents the next stage of this standard development and is now part of the IEC 61800-7 standard.

Some protocols also support the Open DeviceNet Vendor Association profile (ODVA).

### Application Profile

Application profile defines the services to be provided by the devices on a machine. For example, CiA DSP 417-2 V 1.01 part 2: CANopen application profile for lift control systems - virtual device definitions.

### Interchangeability

The aim of communication and functional profiles is to achieve interchangeability of the devices connected via the network.



## Functional Profiles Supported by the Drive

### I/O Profile

Using the I/O profile simplifies PLC programming.

The I/O profile mirrors the use of the terminal strip for control by utilizing 1 bit to control a function.

The I/O profile can also be used when controlling via a network. The drive starts up as soon as the `run` command is sent. 15 bits of the control word (bits 1...15) can be assigned to a specific function.

This profile can be developed for simultaneous control of the drive via:

- The terminals
- The Modbus control word
- The CANopen control word
- The network module control word

The I/O profile is supported by the drive itself and therefore in turn by all the communication ports (integrated Modbus, CANopen, Ethernet, PROFIBUS DP, and DeviceNet communication modules).

### CiA402 Profile

The drive only starts up following a command sequence.

The control word is standardized.

5 bits of the control word (bits 11...15) can be assigned to a function.

The CiA402 profile is supported by the drive itself and therefore in turn by all the communication ports (integrated Modbus, CANopen, Ethernet, PROFIBUS DP, and DeviceNet communication modules).

The drive supports the `velocity` mode of CiA402 profile.

In the CiA402 profile, there are 2 modes that are specific to the Altivar 32 and characterize command and reference management:

- Separate **[Separate]** (`SEP`)
- Not separate **[Not separ.]** (`NS`),

for more information see Operating States.

## Functional Description

### Introduction

Drive operation involves 2 main functions, which are illustrated in the diagrams below.

### CiA402

The main parameters are shown with their CiA402 name and their CiA402/Drivecom index (the values in brackets are the CANopen addresses of the parameter).

The following figure shows the control diagram for drive operation:

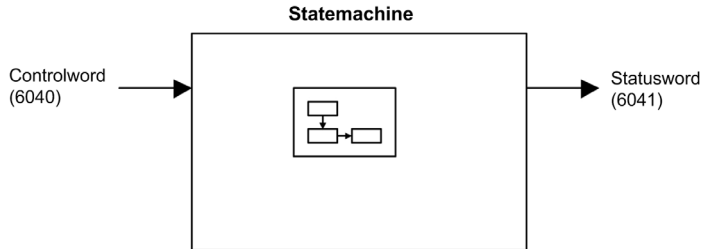

Simplified diagram for speed control in Velocity mode:

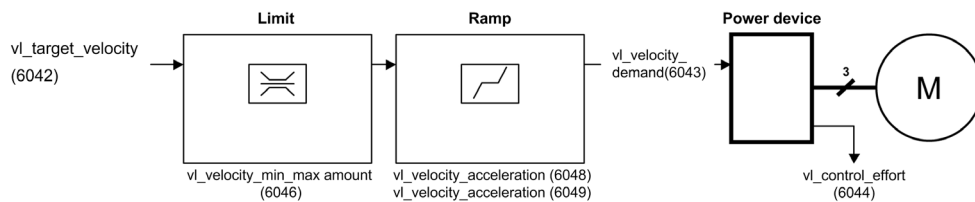

### Altivar Process

These diagrams translate as follows for the Altivar process system.

The following figure shows the control diagram for drive operation:

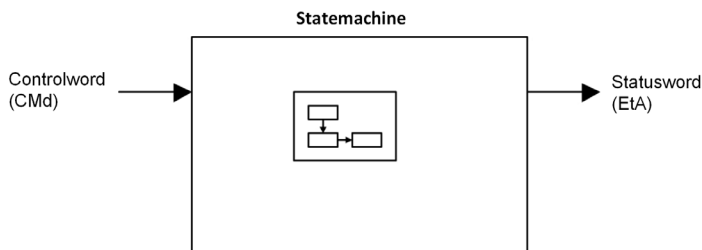

Simplified diagram for speed control in Velocity mode:

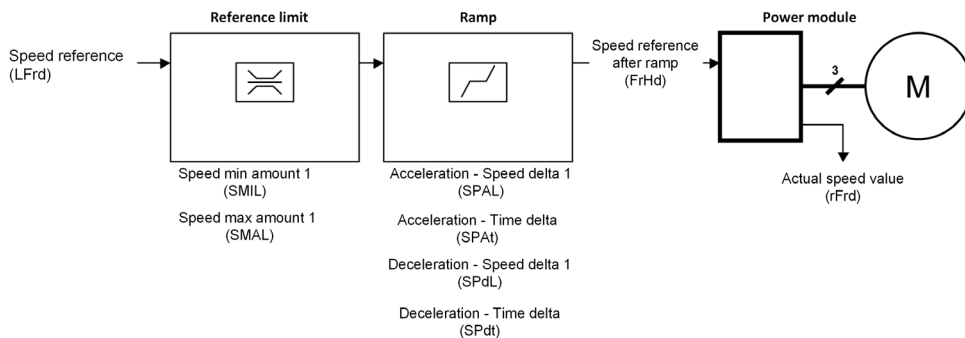

## CIA402 Operating State Diagram

### State Diagram

After switching on and when an operating mode is started, the product goes through a number of operating states.

The state diagram (state machine) shows the relationships between the operating states and the state transitions.

The following figure shows the CIA402 state diagram:

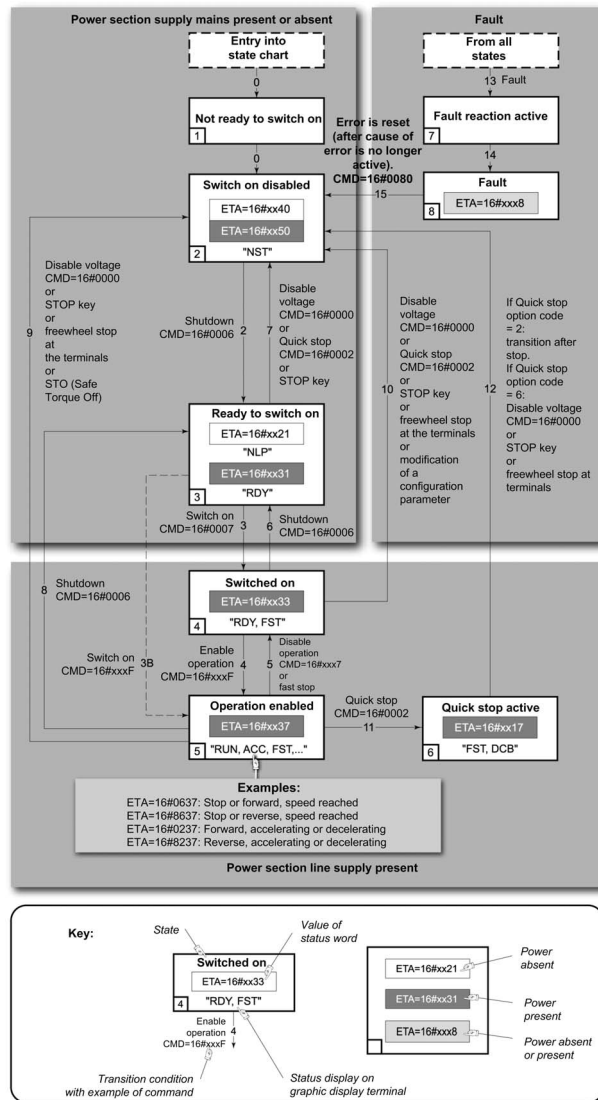

## Description of Operating States

### Drive Operating State

The operating state of the drive changes depending on whether the control word **[Cmd Register] *C P d***, is sent or an event occurs (an error detection, for example).

The drive operating state can be identified by the value of the status word **[CIA402 State Reg] *E L R***.

Operating State	Description
1 - Not ready to switch on	Initialization starts. This is a transient state invisible to the communication network.
2 - Switch on disabled	The power stage is not ready to switch on. The drive is locked, no power is supplied to the motor. For a separate control stage, it is not necessary to supply the power. For a separate control stage with mains contactor, the contactor is not closed. The configuration and adjustment parameters can be modified.
3 - Ready to switch on	The power stage is ready to switch on and awaiting power stage supply mains. For a separate control stage, it is not necessary to supply the power stage, but the system expects it in order to change to state 4 - Switched on. For a separate control stage with mains contactor, the contactor is not closed. The drive is locked, no power is supplied to the motor. The configuration and adjustment parameters can be modified.
4 - Switched on	Power stage is switched on. For a separate control stage, the power stage must be supplied. For a separate control stage with mains contactor, the contactor is closed. The drive is locked, no power is supplied to the motor. The power stage of the drive is ready to operate, but voltage has not yet been applied to the output. The adjustment parameters can be modified. If a configuration parameter is modified, the drive returns to the state 2 - Switch on disable.
5 - Operation enabled	Power stage is enabled. The drive is in running state For a separate control stage, the power stage must be supplied. For a separate control stage with mains contactor, the contactor is closed. The drive is unlocked, power is supplied to the motor. The drive functions are activated and voltage is applied to the motor terminals. If the reference value is zero or the <b>Halt</b> command is applied, no power is supplied to the motor and no torque is applied. To perform <b>[Auto tuning] <i>E u n</i></b> , the drive must be in state 5 - Operation enabled. The adjustment parameters can be modified. The configuration parameters cannot be modified.  <b>NOTE:</b> The command 4 - Enable operation must be taken into consideration only if the channel is valid. In particular, if the channel is involved in the command and the reference value, transition 4 is possible only after the reference value has been received once.  The reaction of the drive to a <b>Disable operation</b> command depends on the value of the <b>[SwitchOnDisable Stp] <i>d o t d</i></b> parameter: <ul style="list-style-type: none"> <li>• If the <b>[SwitchOnDisable Stp] <i>d o t d</i></b> parameter is set to 0, the drive changes to operating state 4 - Switched on and stops in freewheel stop.</li> <li>• If the <b>[SwitchOnDisable Stp] <i>d o t d</i></b> parameter is set to 1, the drive stops on ramp and then changes to operating state 4 - Switched on.</li> </ul>

Operating State	Description
6 - Quick stop active	<p>The drive performs a fast stop and remains locked in the operating state 6-Quick stop active. Before restarting the motor, it is required to go to the operating state 2-switch on disabled.</p> <p>During fast stop, the drive is unlocked and power is supplied to the motor. The configuration parameters cannot be modified.</p> <p>The condition for transition 12 to state 2 - Switch on disabled depends on the value of the parameter Quick stop mode (QStd):</p> <p>If the Quick stop mode parameter has the value FST2, the drive stops according to the fast stop ramp and then changes to state 2 - Switch on disabled.</p> <p>If the Quick stop mode parameter has the value FST6, the drive stops according to the fast stop ramp and then remains in state 6 - Quick stop active until:</p> <ul style="list-style-type: none"> <li>● A Disable voltage command is received or</li> <li>● The <b>STOP</b> key is pressed or</li> <li>● A freewheel stop command via the digital input of the terminal.</li> </ul>
7 - Fault reaction active	Transient state during which the drive performs an action corresponding to the selected error response.
8 - Fault	<p>Error response terminated. Power stage is disabled.</p> <p>The drive is locked, no power is supplied to the motor.</p>

## Summary

### Device Status Summary

State	Power Stage Supply for Separate Control Stage	Power Supplied to Motor	Modification of Configuration Parameters
1 - Not ready to switch on	Not required	No	Yes
2 - Switch on disabled	Not required	No	Yes
3 - Ready to switch on	Not required	No	Yes
4 - Switched on	Required	No	Yes, return to 2 - Switch on disabled state
5 - Operation enabled	Required	Yes	No
6 - Quick stop active	Required	Yes, during fast stop	No
7 - Fault reaction active	Depends on error response	Depends on the error response	-
8 - Fault	Not required	No	Yes

## Cmd Register [ Π ]

### Bit Mapping of the Control Word

Bit 7	Bit 6	Bit 5	Bit 4	Bit 3	Bit 2	Bit 1	Bit 0
Fault reset	Reserved (=0)	Reserved (=0)	Reserved (=0)	Enable operation	Quick stop	Enable voltage	Switch on
0 to 1 transition = Error is reset (after cause of error is no longer active)				1 = Run command	0 = Quick stop active	Authorization to supply AC power	Mains contactor control

Bit 15	Bit 14	Bit 13	Bit 12	Bit 11	Bit 10	Bit 9	Bit 8
Manufacturer specific assignable	Manufacturer specific assignable	Manufacturer specific assignable	Manufacturer specific assignable	Manufacturer specific	Reserved (=0)	Reserved (=0)	Halt
				0 = Forward direction asked 1 = Reverse direction asked			Halt

Command	State Transition	Final Operating State	Bit 7	Bit 3	Bit 2	Bit 1	Bit 0	Example Value
			Fault Reset	Enable Operation	Quick Stop	Enable Voltage	Switch On	
Shutdown	2, 6, 8	3 - Ready to switch on	X	X	1	1	0	0006 hex
Switch on	3	4 - Switched on	X	X	1	1	1	0007 hex
Enable operation	4	5 - Operation enabled	X	1	1	1	1	000F hex
Disable operation	5	4 - Switched on	X	0	1	1	1	0007 hex
Disable voltage	7, 9, 10, 12	2 - Switch on disabled	X	X	X	0	X	0000 hex
Quick stop	11	6 - Quick stop active	X	X	0	1	X	0002 hex
	7, 10	2 - Switch on disabled						
Fault reset	15	2 - Switch on disabled	0 → 1	X	X	X	X	0080 hex

X: Value is of no significance for this command.  
0→1: Command on rising edge.

## Stop Commands

### Halt Command

The `Halt` command enables movement to be interrupted without having to leave the `5 - Operation enabled` state. The stop is performed in accordance with the `[Type of stop] S L L` parameter.

If the `Halt` command is active, no power is supplied to the motor and no torque is applied.

Regardless of the assignment of the `[Type of stop] S L L` parameter (`[Fast stop assign] F S L`, `[Ramp stop] r P P`, `[Freewheel] n S L`, or `[DC injection assign.] d C i`), the drive remains in the `5 - Operation enabled` state.

### Fast Stop Command

A `Fast Stop` command at the terminals or using a bit of the control word assigned to `Fast Stop` causes a change to the `4 - Switched on` state

### Freewheel Command

A `Freewheel Stop` command at the terminals or using a bit of the control word assigned to `Freewheel Stop` causes a change to the `2 - Switch on disabled` state.



## Assigning Control Word Bits

### Function Codes

In the CiA402 profile, fixed assignment of a function input is possible using the following codes:

Bit	Fieldbus Module
Bit 11	C311
Bit 12	C312
Bit 13	C313
Bit 14	C314
Bit 15	C315

For example, to assign the DC injection braking to bit 13 of DeviceNet, simply configure the **[DC injection assign.]** parameter with the **[C313]** value.

Bit 11 is assigned by default to the operating direction command **[Reverse assign.]**.

[CIA402 State Reg] E L F

Bit Mapping of the Status Word

Bit 7	Bit 6	Bit 5	Bit 4	Bit 3	Bit 2	Bit 1	Bit 0
Warning	Switch on disabled	Quick stop	Voltage enabled	Fault	Operation enabled	Switched on	Ready to switch on
A warning is active	Power stage supply disabled	0 = Quick stop is active	Power stage supply present	Error detected	Running	Ready	1 = Awaiting power Stage supply

Bit 15	Bit 14	Bit 13	Bit 12	Bit 11	Bit 10	Bit 9	Bit 8
Manufacturer-specific Direction of rotation	Manufacturer-specific Stop via STOP key	Reserved (=0)	Reserved (=0)	Internal limit active	Target reached	Remote	Reserved (=0)
				Reference value outside limits	Reference value reached	Command or reference value via fieldbus	

Operating State	Bit 6	Bit 5	Bit 4	Bit 3	Bit 2	Bit 1	Bit 0	ETA Masked by 006F H <sup>(1)</sup>
	Switch On Disabled	Quick Stop	Voltage Enabled	Fault	Operation Enabled	Switched On	Ready to Switch On	
1 -Not ready to switch on	0	X	X	0	0	0	0	-
2 -Switch on disabled	1	X	X	0	0	0	0	0040 hex
3 -Ready to switch on	0	1	X	0	0	0	1	0021 hex
4 - Switched on	0	1	1	0	0	1	1	0023 hex
5 - Operation enabled	0	1	1	0	1	1	1	0027 hex
6 -Quick stop active	0	0	1	0	1	1	1	0007 hex
7 -Fault reaction active	0	X	X	1	1	1	1	002F
8 -Fault	0	X	X	1	0	0	0	0008 hex <sup>(2)</sup> .. .0028 hex

<sup>(1)</sup> This mask can be used by the PLC program to test the diagram state.

<sup>(2)</sup> detected error following operating state 6 - Quick stop active.

X: In this state, the value of the bit can be 0 or 1.

## Starting Sequence

### Description

The command sequence in the state chart depends on how power is being supplied to the drive.

There are 3 possible scenarios:

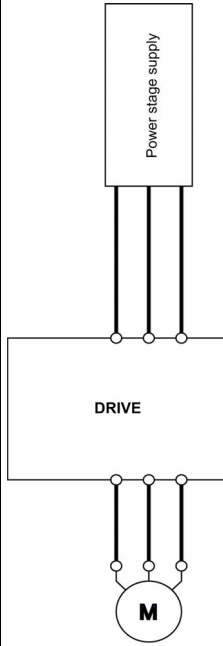
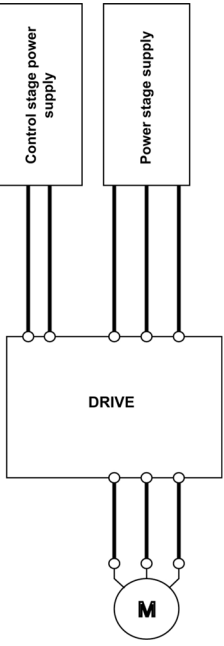
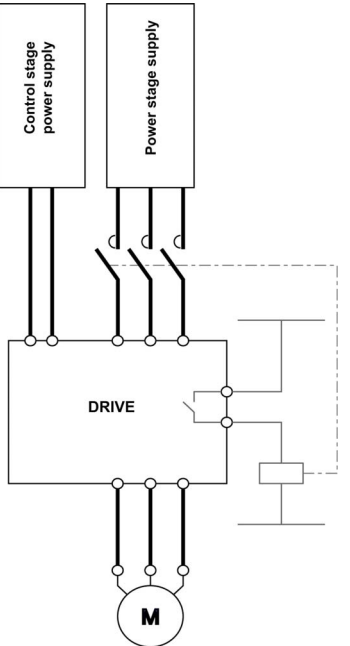
			
<b>Power section line supply</b>	Direct	Direct	Line contactor controlled by the drive
<b>Control section power supply</b>	Not separate <sup>(1)</sup>	Separate	Separate
<sup>(1)</sup> The power section supplies the control section.			

## Sequence for a Drive Powered by the Power Stage Supply

### Description

Both the power and control stages are powered by the power stage supply. If power is supplied to the control stage, it has to be supplied to the power stage as well. The following sequence must be applied:

### Step 1

Apply the 2 - Shut down command

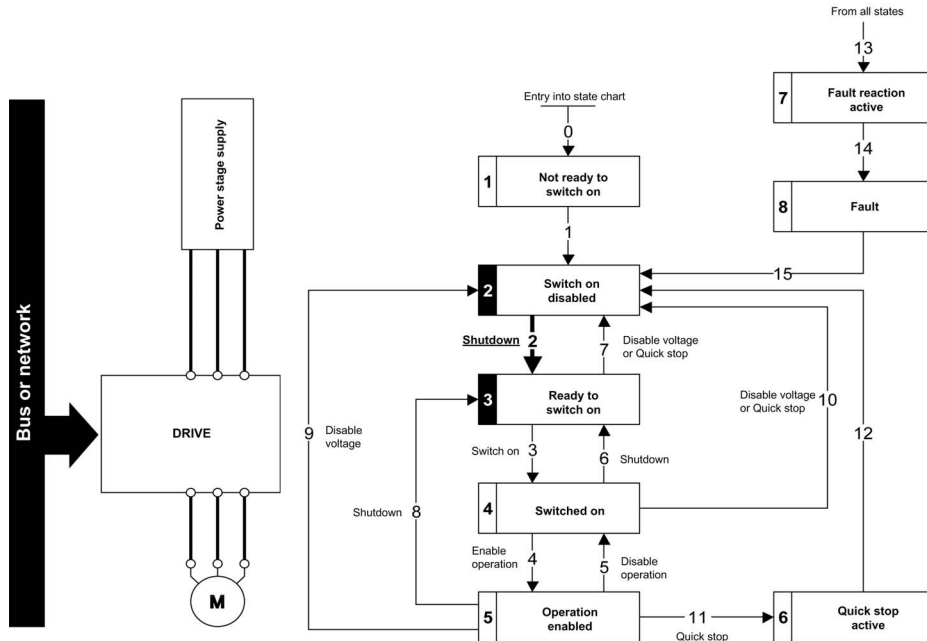

### Step 2

- Check that the drive is in the operating state 3 - Ready to switch on.
- Then apply the 4 - Enable operation command.
- The motor can be controlled (send a reference value not equal to zero).

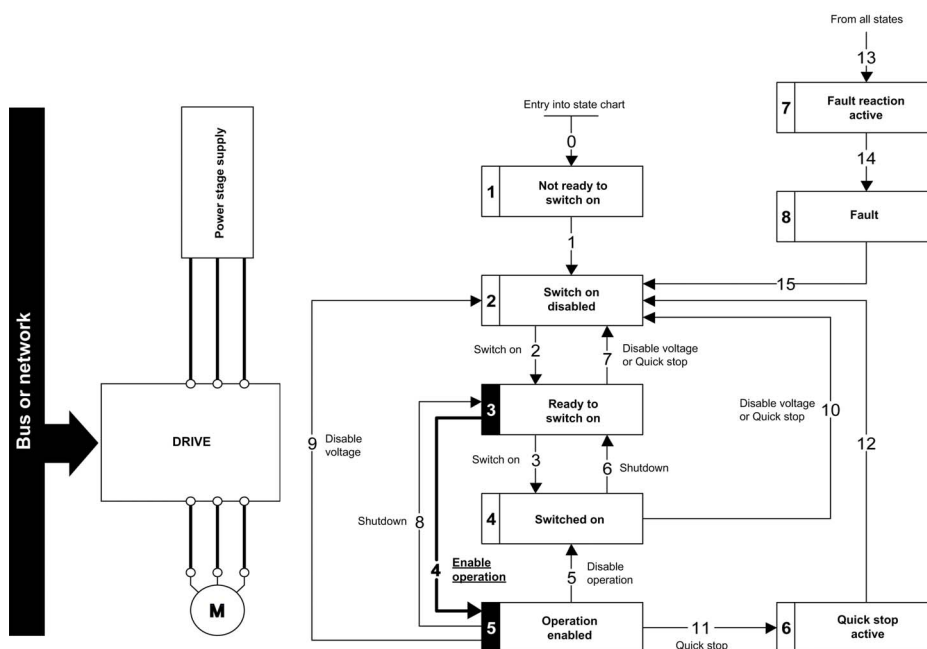

**NOTE:** It is possible, but not necessary to apply the 3 - Switch on command followed by the 4 - Enable Operation command to switch successively into the operating states 3 - Ready to Switch on, 4 - Switched on and then 5 - Operation Enabled. The 4 - Enable operation command is sufficient.

## Sequence for a Drive with Separate Control Stage

### Description

Power is supplied separately to the power and control stages.

If power is supplied to the control stage, it does not have to be supplied to the power stage as well.

The following sequence must be applied:

### Step 1

- The power stage supply is not necessarily present.
- Apply the 2 - Shut down command

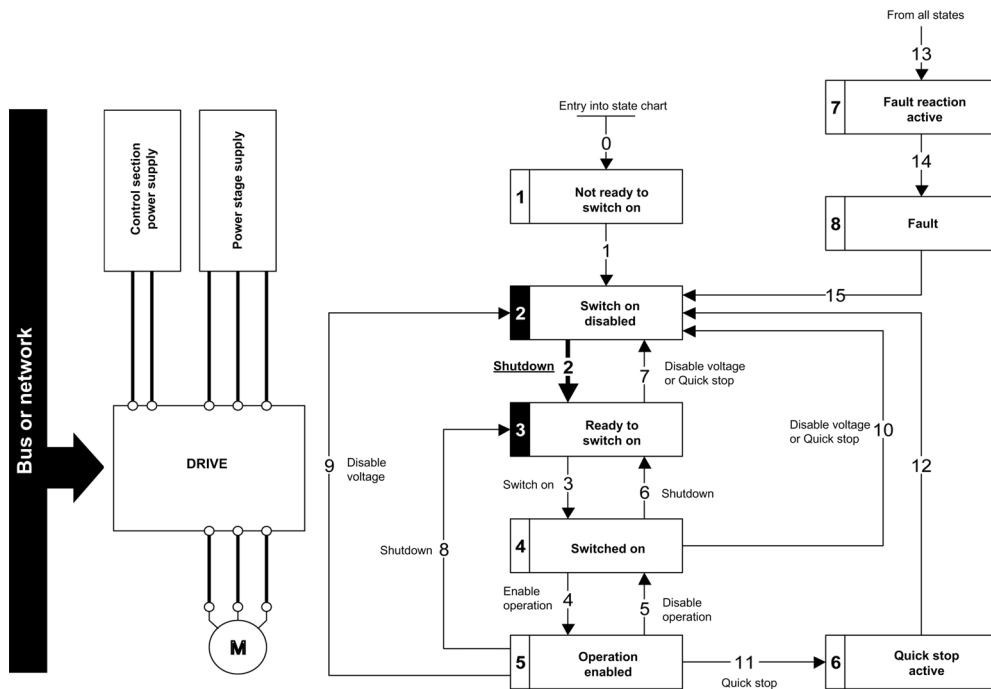

### Step 2

- Check that the drive is in the operating state 3 - Ready to switch on.
- Check that the power stage supply is present (Voltage enabled of the status word).

Power Stage Supply	Terminal Display	Status Word
Absent	<i>n L P</i>	21 hex
Present	<i>r d Y</i>	31 hex

- Apply the 3 - Switch on command

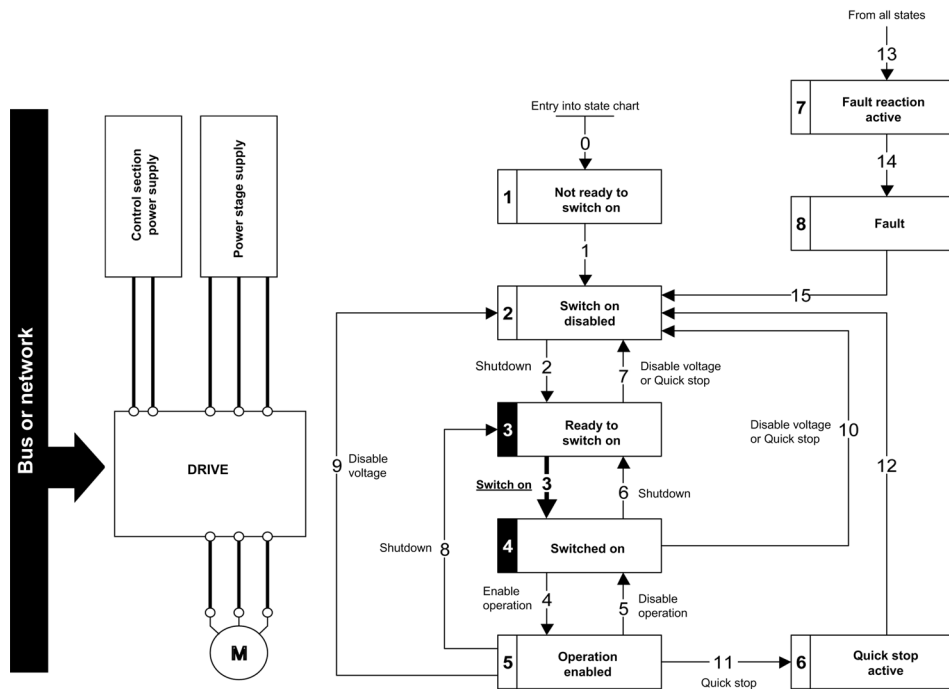

Step 3

- Check that the drive is in the operating state 4 - Switched on.
- Then apply the 4 - Enable operation command.
- The motor can be controlled (send a reference value not equal to zero).
- If the power stage supply is still not present in the operating state 4 - Switched on after a time delay [Mains V. time out] L C E, the drive triggers an error [Input Contactor] L C F.

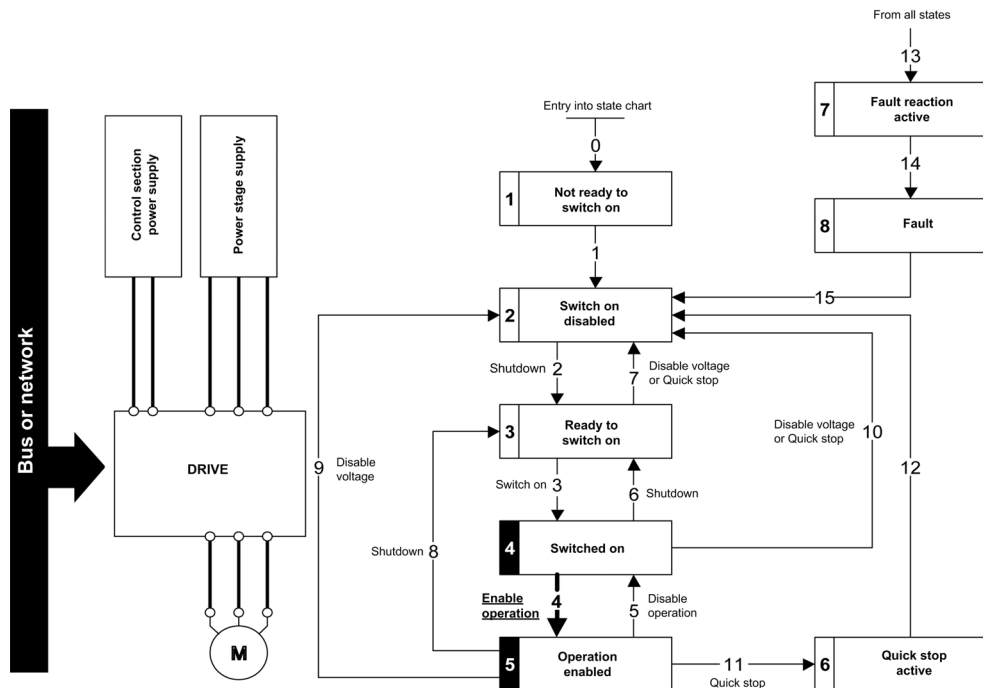

## Sequence for a Drive with Mains Contactor Control

### Description

Power is supplied separately to the power and control stages.

If power is supplied to the control stage, it does not have to be supplied to the power stage as well. The drive controls the mains contactor.

The following sequence must be applied:

### Step 1

- The power stage supply is not present as the mains contactor is not being controlled.
- Apply the 2 - `Shutdown` command.

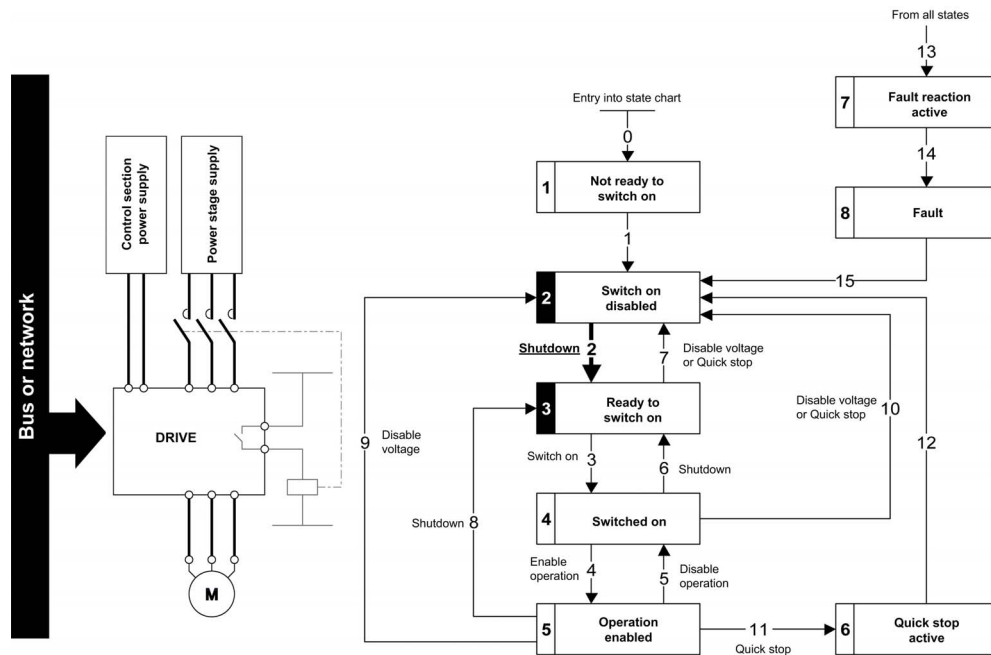

### Step 2

- Check that the drive is in the operating state 3 - `Ready to switch on`.
- Apply the 3 - `Switch on` command, which closes the mains contactor and switch on the power stage supply.



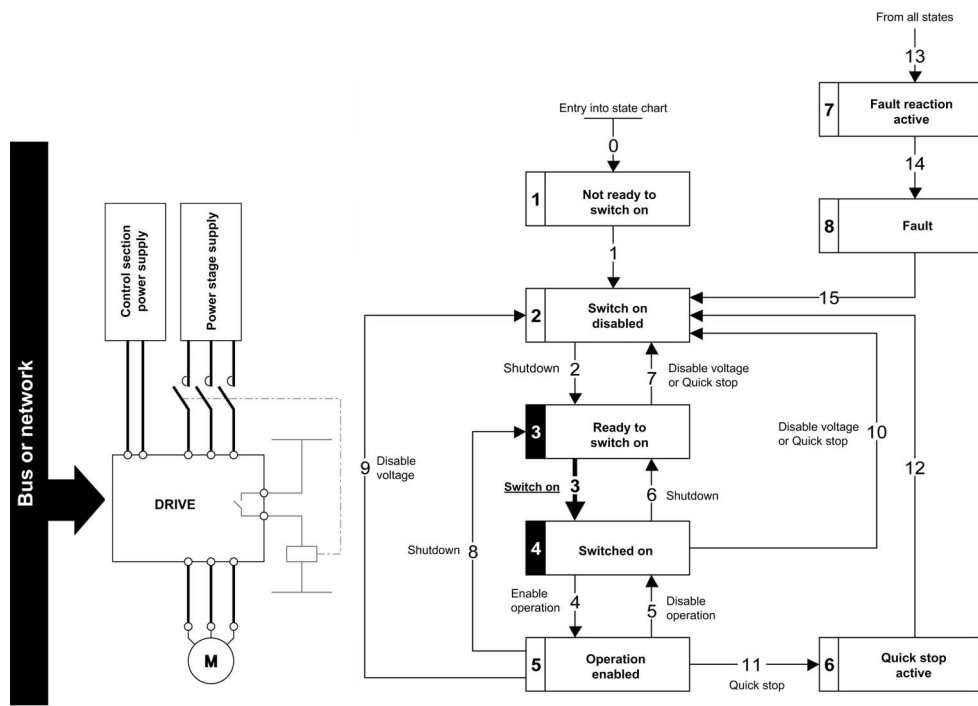

## Available Profiles with the VWA3609 Fieldbus Module

### Description

The VWA3609 fieldbus module enables the control of the drive according to:

- ODVA AC drive profile: basic and extended speed profiles.
- Drive native profile (CiA402) through the drive communication scanner.

### Output Assemblies

The table provides the description of available Output Assemblies:

Assembly Name	Number	Size
CIP basic speed control output	20	Two words (4 bytes)
CIP extended speed control output	21	Two words (4 bytes)
Native drive output	100	Four words (8 bytes)

The size of the communication scanner is reduced to four words for optimal performances.

### Input Assemblies

The table provides the description of available Input Assemblies:

Assembly Name	Number	Size
CIP basic speed control input	70	Two words (4 bytes)
CIP extended speed control input	71	Two words (4 bytes)
Native drive input	101	Four words (8 bytes)

The native drive profile assemblies use the communication scanner.

## Control with Communication Scanner

### Description

If the default assemblies (100, 101) are selected, all possibilities of the drive are available.

It is possible to use all profiles and modes of the drive:

- I/O profile,
- CiA402 profile with separate or non-separate mode.

By the configuration of the communication scanner, it is possible to assign any relevant parameter of the drive to the four input and four output variables of the assemblies.

### Assembly 100: Native Drive Output

The table describes the output assembly mapping:

Word Number	Definition
1	Control word
2	Velocity setpoint
3	Scanner write word 3
4	Scanner write word 4

The table describes the drive assignment:

Word Number	Code	Name
1	OCA1	Communication scanner, address of write word 1 (default value: CMD, Control word)
2	OCA2	Communication scanner, address of write word 2 (default value: LFRD, velocity setpoint)
3	OCA3	Communication scanner, address of write word 3
4	OCA4	Communication scanner, address of write word 4

### Assembly 101: Native Drive Output

The table describes the input assembly mapping:

Word Number	Definition
1	Status word
2	Actual speed
3	Scanner read word 3
4	Scanner read word 4

The table describes the drive assignment:

Word Number	Code	Name
1	OMA1	Communication scanner, address of read word 1 (default value: Status word, ETA)
2	OMA2	Communication scanner, address of read word 2 (default value: velocity actual value, RFRD)
3	OMA3	Communication scanner, address of read word 3
4	OMA4	Communication scanner, address of read word 4

## Control According to ODVA AC Drive Profile

### Description

The ODVA AC drive profile is activated when one of the following assemblies are selected:

- 20: Basic speed control output
- 21: Extended speed control output
- 70: Basic speed control input
- 71: Extended speed control input

The advantage of using the ODVA drive profile standard is the interchangeability with other brands.

The drive must be configured in the CiA402 profile with separate mode.

The DeviceNet card translates the commands, behavior, and monitoring information from of ODVA profile (on the network) to the Drivecom profile (in the drive).

### Assembly 20

The table describes the assembly mapping:

Word Number	Definition
0	CIP basic command word
1	Speed setpoint (rpm)

The table describes the CIP basic command word:

Bit 7	Bit 6	Bit 5	Bit 4	Bit 3	Bit 2	Bit 1	Bit 0
Not used	Not used	Not used	Not used	Not used	Detected error reset <sup>(1)</sup> 0 = No command 1 = detected error reset	Not used	Run forward <sup>(2)</sup> 0 = Stop 1 = Run
<sup>(1)</sup> Active on rising edge <sup>(2)</sup> Active on level							

Bit 15	Bit 14	Bit 13	Bit 12	Bit 11	Bit 10	Bit 9	Bit 8
Not used	Not used	Not used	Not used	Not used	Not used	Not used	Not used

### Assembly 70

The table describes the assembly mapping:

Word Number	Definition
0	CIP basic status word
1	Actual speed (rpm)

The table describes the CIP basic status word:

Bit 7	Bit 6	Bit 5	Bit 4	Bit 3	Bit 2	Bit 1	Bit 0
Not used	Not used	Not used	Not used	Not used	Running 0 = Stopped 1 = Running	Not used	Detected error 0 = No error detected 1 = error detected

Bit 15	Bit 14	Bit 13	Bit 12	Bit 11	Bit 10	Bit 9	Bit 8
Not used	Not used	Not used	Not used	Not used	Not used	Not used	Not used

## Assembly 21

The table describes the assembly mapping:

Word Number	Definition
0	CIP basic command word
1	Speed setpoint (rpm)

The table describes the CIP extended command word:

Bit 7	Bit 6	Bit 5	Bit 4	Bit 3	Bit 2	Bit 1	Bit 0
Not used	Network setpoint 0 = Setpoint by terminals 1 = Setpoint by network	Network command 0 = Command by terminals 1 = Command by network	Not used	Not used	Detected error reset <sup>(1)</sup> 0 = No command 1 = detected error reset	Run forward/reverse 00 = Quick stop 01 = Run forward 10 = Run reverse 11 = No action	
<sup>(1)</sup> Active on rising edge							

Bit 15	Bit 14	Bit 13	Bit 12	Bit 11	Bit 10	Bit 9	Bit 8
Not used	Not used	Not used	Not used	Not used	Not used	Not used	Not used

## Assembly 71

The table describes the assembly mapping:

Word Number	Definition
0	CIP basic status word
1	Actual speed (rpm)

The table describes the CIP extended status word:

Bit 7	Bit 6	Bit 5	Bit 4	Bit 3	Bit 2	Bit 1	Bit 0
At reference 0 = reference not reached 1 = reference reached	Setpoint from network 0 = Setpoint from terminals 1 = Setpoint from network	Command from network 0 = Command from terminals 1 = Command from network	Ready 0 = Not ready 1 = Ready	Running forward/reverse 00 = Stopped 01 = Running forward 10 = Running reverse 11 = Not used	Warning 0 = No warning 1 = Warning	Not used	

Bit 15	Bit 14	Bit 13	Bit 12	Bit 11	Bit 10	Bit 9	Bit 8
Not used	Not used	Not used	Not used	Not used	Bit 8 to bit 10 are used for the drive state 000 = Not used 001 = Start-up 010 = Not ready 011 = Ready 100 = Enabled 101 = Stopping 110 = Fault_Stop 111 = error detected		

## Section 4.4

### Fieldbus Integration Tutorial

---

#### What Is in This Section?

This section contains the following topics:

Topic	Page
EDS Integration	95
Drive Configuration	98
Acyclic Messaging from Control Logix PLC	100

## EDS Integration

### Installation of the EDS File

The EDS file of the VW3A3609 fieldbus module can be downloaded from [www.schneider-electric.com](http://www.schneider-electric.com). To install the new EDS file, you can launch the EDS wizard from the tools entry of **RSNetWorx** menu.

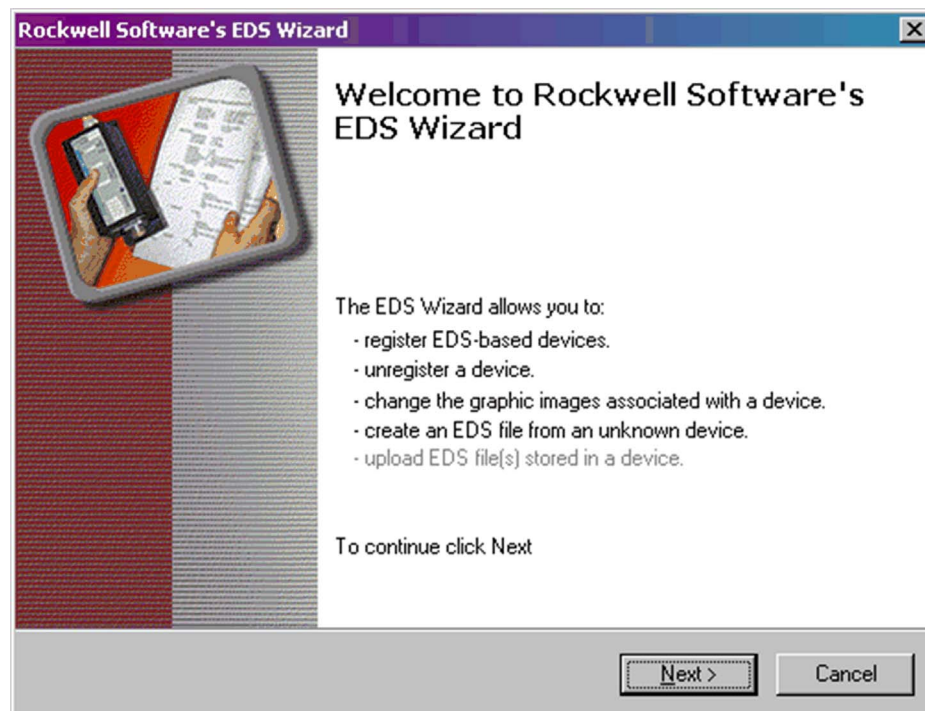
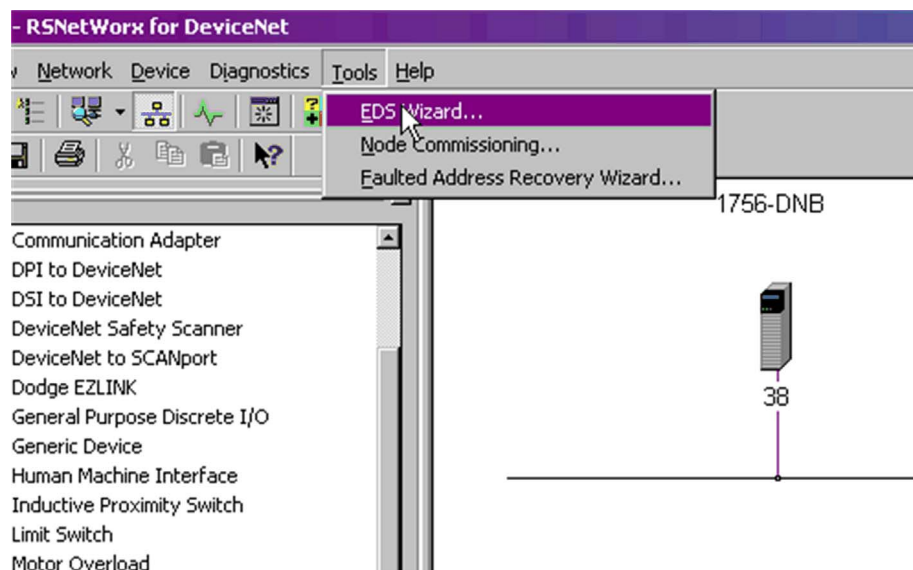

Click **Next**

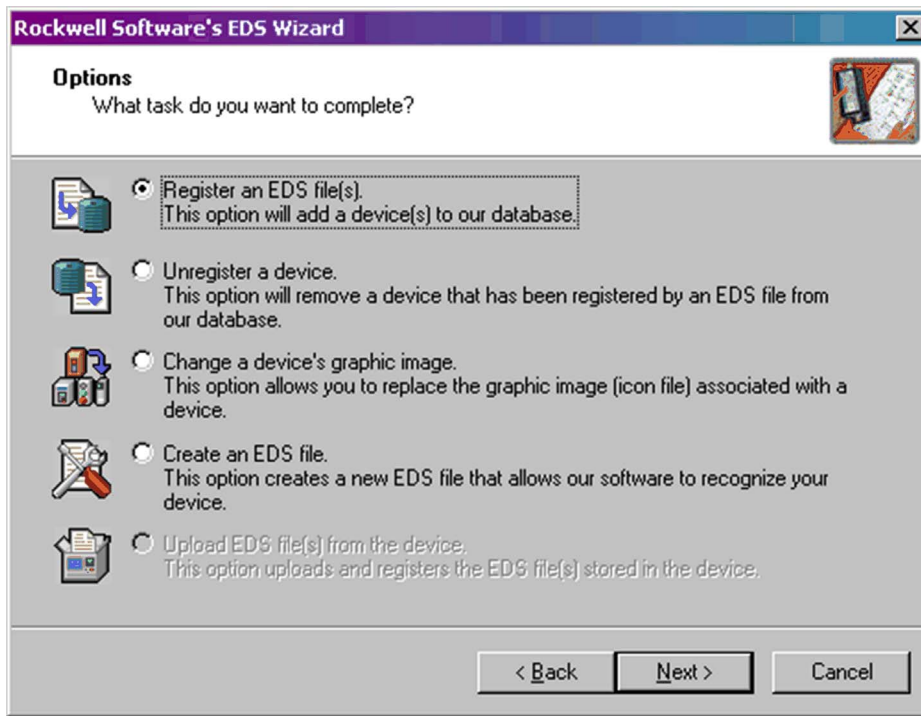

Click **Next**

Select the location where the EDS file has been recorded:

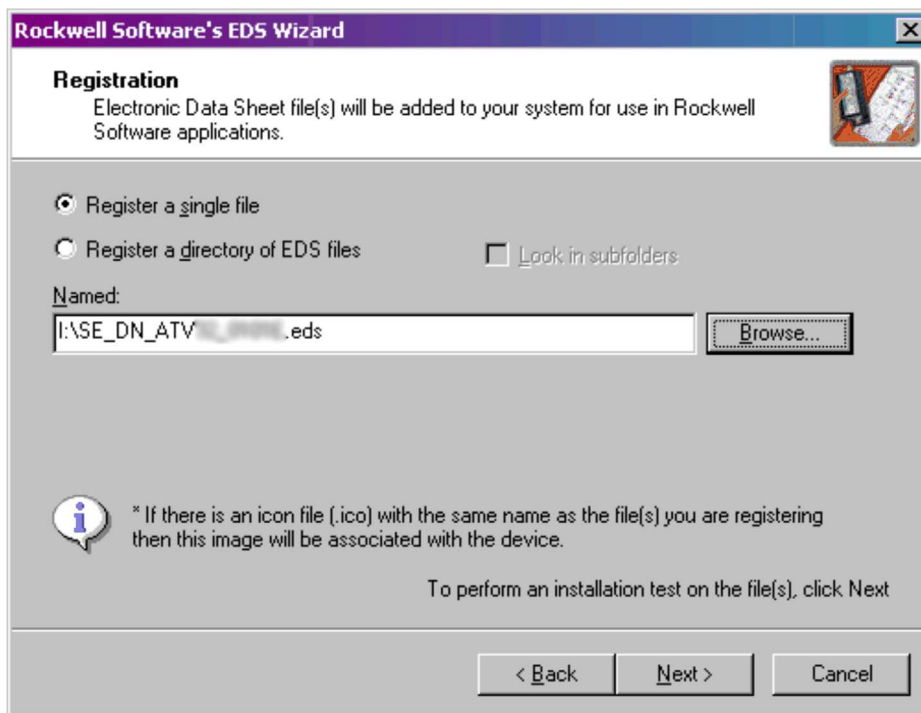

Click **Next**



You should get the following result, that indicates that the EDS file has been successfully imported.

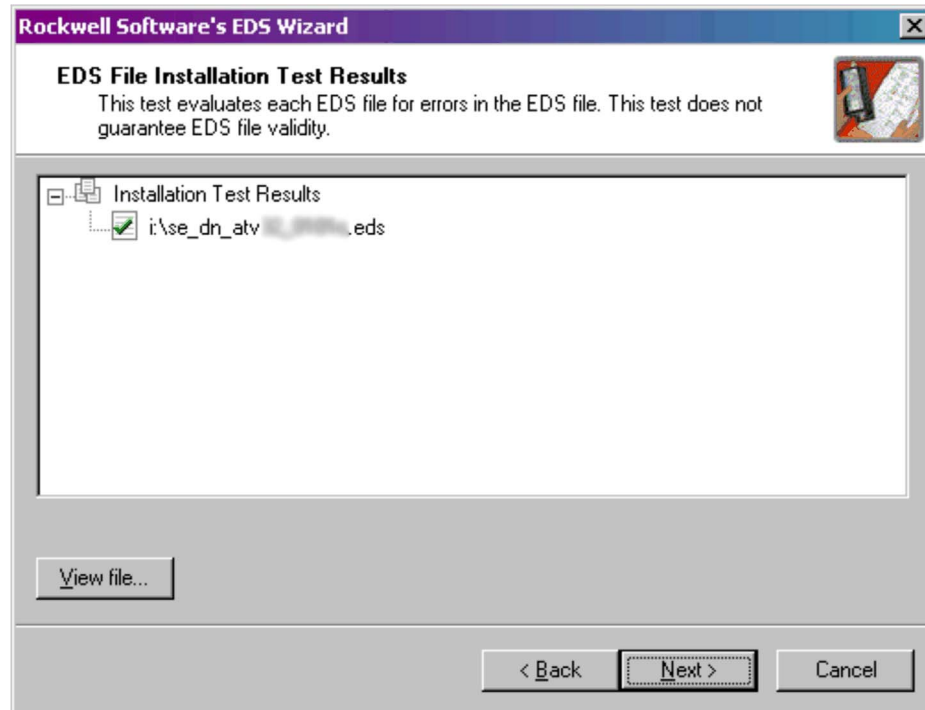

Click **Next**, the wizard proposes you to change the icon picture associated to the device. If you do not want to change the icon file click **Next** to terminate the EDS registration.

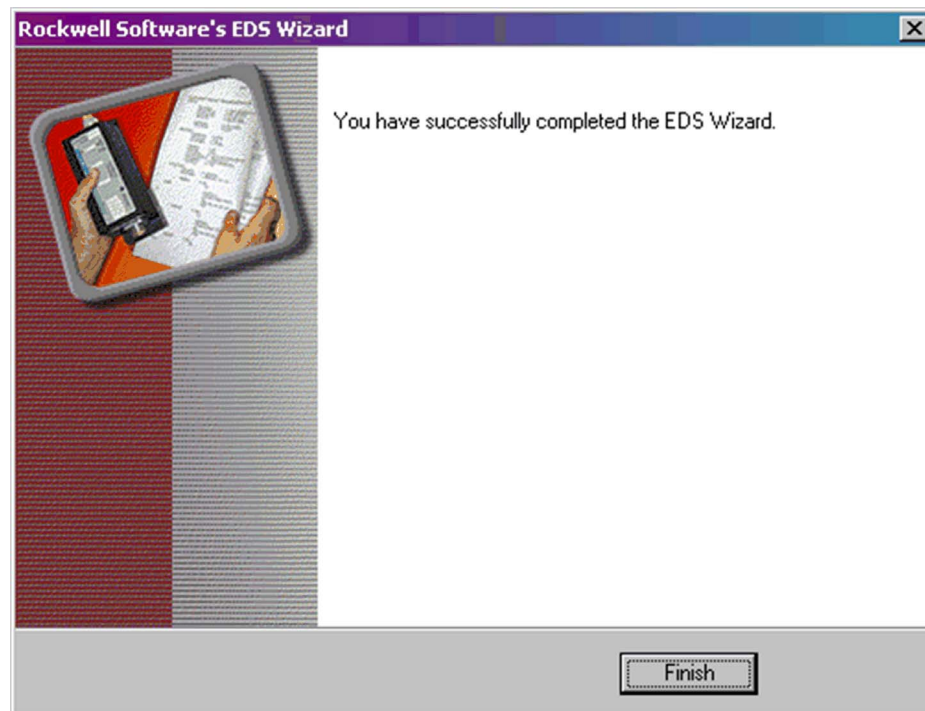

## Drive Configuration

### Configuration of the DeviceNet Module in a Rockwell PLC

In the example, the module is installed in the first slot of the local base plate of a 1755 CPU:

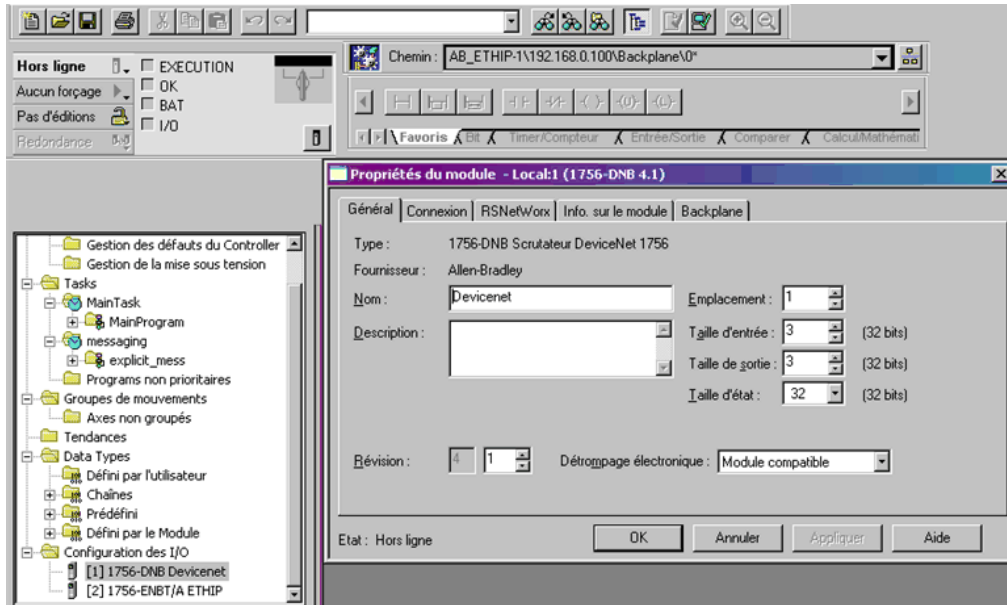

The DeviceNet module is identified with the symbol: **Module\_DNET** . This identifier will be used later with tools like the class instance editor.

### Configuring the Implicit Exchanges

The drive allows the use of 3 assemblies set as described in previous chapter. In the 3 cases the input size and the output size are always the same.

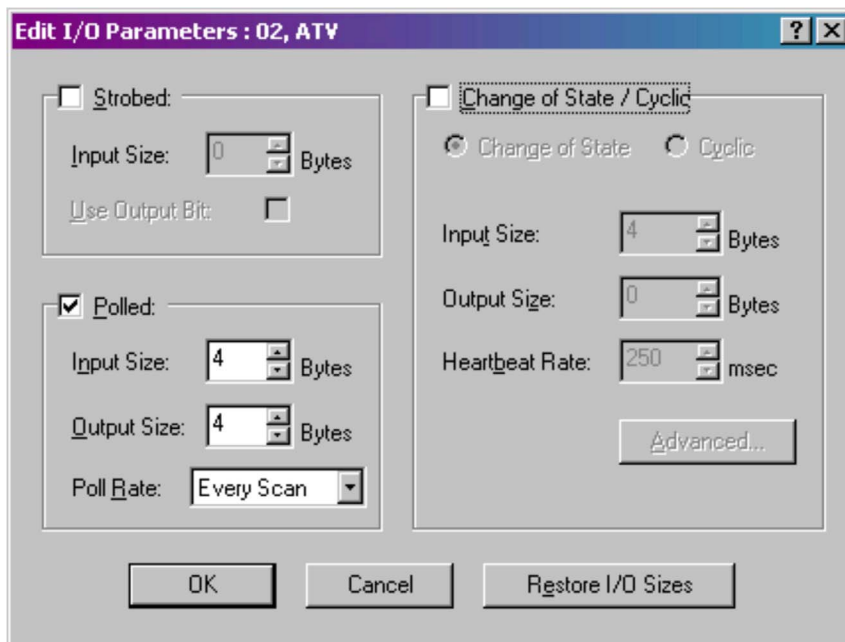

Class Instance Editor

The screenshot displays the 'Class Instance Editor' application. The main window features a hardware tree on the left side, listing various components like 'Communication Adapter', 'DPI to DeviceNet', and 'Vendor'. The central area shows a graph with two nodes, '3B' and '2A'. A dialog box titled 'Class Instance Editor - [Node 2]' is open, allowing configuration of transaction arguments. The dialog includes sections for 'Execute Transaction Arguments' and 'Receive Data'. The 'Execute Transaction Arguments' section contains a table for 'Object Address' with columns for Class, Instance, and Attribute, and a 'Service Code' dropdown. The 'Receive Data' section includes 'Output size format' and 'Output radix format' dropdowns. Below the dialog, a 'Messages' window shows a log entry for 'DNET:0101' at 5/20/2010 14:37:30 with the description 'Mode changed to online. The online path is W\FR63983DIAB\_ETHIP-1\192.168.0.100\Backplane\1\A.'

## Acyclic Messaging from Control Logix PLC

### Description

The drive parameters are grouped in classes:

- Each application class has only 1 instance.
- Each instance group 200 parameter.
- Each attribute in an instance relates to a parameter.
- The first parameter is registered in the first application.

### Examples

Class code = ((ADL - 3000)/200) + 70 hex

Attribute ID = (ADL modulo 200)+1

Instance = 1

Modbus Address	Hexadecimal Path
3000	70 hex/01/01
3100	70 hex/01/65
3201	71 hex/01/02

---

# Chapter 5

## Operations

---

### What Is in This Chapter?

This chapter contains the following sections:

Section	Topic	Page
5.1	Operating States	102
5.2	Operating Modes	103

## Section 5.1 Operating States

### Configuring Communication Error Response

#### Description

The response of the drive in the event of communication interruption can be configured. Configuration can be performed using the display terminal from the **[Complete settings] C 5 E -**, **[Error/Warning handling] C 5 W Π -** menu, **[Communication Module] C 0 Π 0 -** submenu, via the **[Fieldbus Interrupt Resp] C L L** parameter.

The values of the parameter, which triggers a transition to the operating state faults are:

Value	Meaning
<b>[Freewheel Stop] 4 E 5</b>	Freewheel stop (factory setting)
<b>[Ramp stop] r Π P</b>	Stop on ramp
<b>[Fast stop] F 5 E</b>	Fast stop
<b>[DC injection] d C ,</b>	DC injection stop

The values of the parameter, which does not trigger a transition to the operating state faults are:

Value	Meaning
<b>[Ignore] n 0</b>	Detected error ignored
<b>[Per STT] 5 E E</b>	Stop according to configuration of <b>[Type of stop] 5 E E</b>
<b>[Fallback Speed] L F F</b>	Change to fallback speed, maintained as long as the detected error persists and the run command has not been removed
<b>[Speed maintained] r L 5</b>	The drive maintains the speed at the time the detected error occurred, as long as the detected error persists, and the run command has not been removed

The fallback speed can be configured in the **[Complete settings] C 5 E -**, **[Error/Warning handling] C 5 W Π -** menu, **[Fallback speed] L F F -** submenu, using the **[FallbackSpeed] L F F** parameter.

**WARNING**

**LOSS OF CONTROL**

If this parameter is set to **n 0**, fieldbus communication monitoring is disabled.

- Only use this setting after a thorough risk assessment in compliance with all regulations and standards that apply to the device and to the application.
- Only use this setting for tests during commissioning.
- Verify that communication monitoring has been re-enabled before completing the commissioning procedure and performing the final commissioning test.

**Failure to follow these instructions can result in death, serious injury, or equipment damage.**

---

## Section 5.2

### Operating Modes

---

#### What Is in This Section?

This section contains the following topics:

Topic	Page
Available Configurations	104
Control Via DeviceNet in I/O Profile	105
Control Via DeviceNet or Via the Terminals in I/O Profile	106
Control Via DeviceNet in Drivecom Profile	107
Control Via DeviceNet or the Terminals in CiA402 Profile	108
Control in Drivecom Profile Via DeviceNet and Setpoint Switching at the Terminals	109

## Available Configurations

### Communication Scanner

The following are the list of communication scanners:

- 100: Communication scanner output
- 101: Communication scanner input there is no limitation in the configuration of the control

### ODVA AC Drive Profile

The following are the list of ODVA AC drive profile:

- 20: Basic speed control output
- 21: Extended speed control output
- 70: Basic speed control input
- 71: Extended speed control input

Configuration via the display terminal.

The following 2 cases can be used when the assemblies 20/70 ([Conf. Assembly] C<sub>10</sub>A = [20/70] 2 D) or 21/71 ([Conf. Assembly] C<sub>10</sub>A = [21/71] 2 I) are selected. If the configuration is not done as described, the drive will trip in [External Error] E P F 2 when trying to establish the communication.

- **Case 1:** Setpoint 1B is connected to the functions (Summing, PID, and so on) which remain active even after switching:

Menu	Parameter	Permitted Value
[Command and Reference] C <sub>10</sub> P -	[Control Mode] C H C F	[Separate] S E P
	[Ref.1B channel] F r 1 b	[AI1] A <sub>1</sub> 1 or [AI2] A <sub>1</sub> 2
	[Cmd channel 1] C d 1	[Com. Module] n E t
	[Cmd channel 2] C d 2	[Terminals] t E r
	[Command Switching] C C 5	[C312] C 3 1 2
	[Ref Freq Channel 1] F r 1	[Com. Module] n E t
	[Ref 1B switching] r C b	[C313] C 3 1 3

- **Case 2:** Setpoint 2 is directly connected to the drive reference limit. If switching is performed, the functions that affect the reference (summing, PID, and so on) are inhibited:

Menu	Parameter	Permitted Value
[Command and Reference] C <sub>10</sub> P -	[Control Mode] C H C F	[Separate] S E P
	[Ref Freq Channel 1] F r 1	[Com. Module] n E t
	[Ref Freq Channel 2] F r 2	[AI1] A <sub>1</sub> 1 or [AI2] A <sub>1</sub> 2
	[Cmd channel 1] C d 1	[Com. Module] n E t
	[Cmd channel 2] C d 2	[Terminals] t E r
	[Command Switching] C C 5	[C312] C 3 1 2
	[Ref Freq 2 Switching] r F C	[C313] C 3 1 3

**NOTE:** It is not possible to configure the display terminal as a channel. To switch to the display terminal, use the function force local and assign the parameter [Forced local Freq] F L o C to [HMI] L C C.



## Control Via DeviceNet in I/O Profile

### Description

This configuration can only be used if the communication scanner assemblies (100 and 101) are selected ([Conf. Assembly] *C i a R* = [100/101] *I D D*).

The command and the setpoint come from DeviceNet. Control is in I/O profile.

### Parameter Configuration

Configuration via the display terminal:

Menu	Parameter	Value
[Command and Reference] <i>C r P -</i>	[Control Mode] <i>C H C F</i>	[I/O profile] <i>i o</i>
	[Ref Freq channel 1] <i>F r 1</i>	[Com. Module] <i>n E t</i>
	[Cmd channel 1] <i>C d 1</i>	[Com. Module] <i>n E t</i>

## Control Via DeviceNet or Via the Terminals in I/O Profile

### Description

This configuration can only be used if the communication scanner assemblies (100 and 101) are selected ([Conf. Assembly] *C i o A* = [100/101] *I O D*).

The command and the setpoint both come from DeviceNet or the terminals. Input DI5 at the terminals is used to switch between DeviceNet and the terminals.

Control is in I/O profile.

### Parameter Configuration

**NOTE:** Setpoint 1B is connected to the functions (Summing, PID, so on) which remain active even after switching.

Configuration via the display terminal:

Menu	Parameter	Value
[Command and Reference] <i>C r P -</i>	[Control Mode] <i>C H C F</i>	[I/O profile] <i>i o</i>
	[Ref Freq Channel 1] <i>F r 1</i>	[Com. Module] <i>n E t</i>
	[Cmd channel 1] <i>C d 1</i>	[Com. Module] <i>n E t</i>
	[Cmd channel 2] <i>C d 2</i>	[Terminals] <i>t E r</i>
	[Cmd switching] <i>C C S</i>	[DI5] <i>d i 5</i>
	[Ref.1B channel] <i>F r 1 b</i>	[AI1 ref.] <i>A i 1</i>
	[Ref 1B switching] <i>r C b</i>	[DI5] <i>d i 5</i>

## Control Via DeviceNet in Drivecom Profile

### Description

This configuration can only be used if the communication scanner assemblies (100 and 101) are selected ([Conf. Assembly] *C r P* = [100/101] *I D D*).

The command and the setpoint come from DeviceNet.

### Parameter Configuration

Configuration via the display terminal:

Menu	Parameter	Value
[Command and Reference] <i>C r P</i> -	[Control Mode] <i>C H C F</i>	[Separate] <i>S E P</i>
	[Ref Freq Channel 1] <i>F r 1</i>	[Com. Module] <i>n E t</i>
	[Cmd channel 1] <i>C d 1</i>	[Com. Module] <i>n E t</i>

## Control Via DeviceNet or the Terminals in CiA402 Profile

### Description

This configuration can only be used if the communication scanner assemblies (100 and 101) are selected ([Conf. Assembly] *C i A R* = [100/101] *I D D*).

The command and the setpoint both come from DeviceNet or the terminals. Input DI5 at the terminals is used to switch between DeviceNet and the terminals.

### Parameter Configuration

Configuration via the display terminal:

Menu	Parameter	Value
[Command and Reference] <i>C r P -</i>	[Control Mode] <i>C H C F</i>	[Separate] <i>S E P</i>
	[Ref Freq Channel 1] <i>F r 1</i>	[Com. Module] <i>n E t</i>
	[Ref Freq Channel 2] <i>F r 2</i>	[AI1 ref.] <i>R i 1</i>
	[Ref Freq 2 switching] <i>r F C</i>	[DI5] <i>d i 5</i>
	[Cmd channel 1] <i>C d 1</i>	[Com. Module] <i>n E t</i>
	[Cmd channel 2] <i>C d 2</i>	[Terminals] <i>t E r</i>
	[Command Switching] <i>C C 5</i>	[DI5] <i>d i 5</i>

## Control in Drivecom Profile Via DeviceNet and Setpoint Switching at the Terminals

### Description

This configuration can only be used if the communication scanner assemblies (100 and 101) are selected ([Conf. Assembly] *C i o R* = [100/101] *I D D*).

The command comes from DeviceNet.

The setpoint comes either from DeviceNet or from the terminals. Input DI5 at the terminals is used to switch the setpoint between DeviceNet and the terminals.

Control is in Drivecom profile.

### Parameter Configuration

Configuration via the display terminal:

Menu	Parameter	Value
[Command and Reference] <i>C r P -</i>	[Control Mode] <i>C H C F</i>	[Separate] <i>S E P</i>
	[Ref Freq Channel 1] <i>F r l</i>	[Com. Module] <i>n E t</i>
	[Cmd channel 1] <i>C d l</i>	[Com. Module] <i>n E t</i>
	[Cmd switching] <i>C C S</i>	[Ch1 active] <i>C d l</i>
	[Ref.1B channel] <i>F r L b</i>	[Ai1 ref.] <i>R i i</i>
	[Ref.1B switching] <i>r C b</i>	[DI5] <i>d i 5</i>



---

# Chapter 6

## Diagnostics and Troubleshooting

---

### What Is in This Chapter?

This chapter contains the following topics:

Topic	Page
Fieldbus Status LEDs	112
Connection for Fieldbus Mode	115
Monitoring of Communication Channel	116
Communication Interruption	118

## Fieldbus Status LEDs

### LED Indicators

The following figure describes the LEDs status for the module:

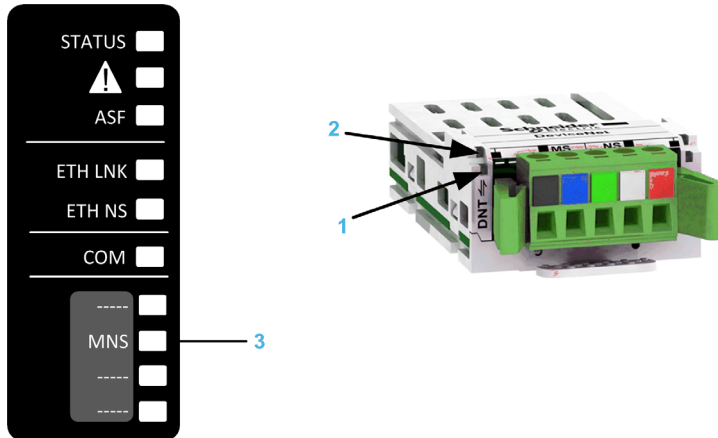

### LED Description

Item	LED	Description
1	NS	Network status LED
2	MS	Module status LED
3	MNS	MS/NS combined LEDs

### LED NS: Network Status

These LEDs indicate the network status

Color & status	Description
OFF	<ul style="list-style-type: none"> <li>The device is not powered.</li> <li>The device has not completed the duplicate node address test.</li> </ul>
Green flashing	The device is on line and operating in a normal condition, but network connections are not established: <ul style="list-style-type: none"> <li>The device has passed the duplicate node address test and is on line, but has not established connections to other nodes.</li> <li>The device is not allocated to a master.</li> <li>Configuration is missing, incomplete, or incorrect.</li> </ul>
Green ON	The device is operating in a normal condition. It is allocated to a master.
Red flashing	<ul style="list-style-type: none"> <li>The device has detected a recoverable error.</li> <li>One or more I/O connections timed out.</li> </ul>
Red ON	<ul style="list-style-type: none"> <li>The device has detected a recoverable error. One or more I/O connections timed out.</li> <li>The device has detected error that has rendered it incapable communicating on the network (duplicate node address or bus turned off)..</li> </ul>
Green/Red flashing	The device has detected a network access error and is in the communication interruption state. The device has then received and accepted an identify communication interruption request-Long protocol message.



**LED MS: Module Status**

This LED indicates the module status:

Color & Status	Description
OFF	The device is not powered.
Green ON	The device is on line and operating in a normal condition.
Green flashing	The device needs commissioning due to configuration missing, incomplete, or incorrect. The device may be in the standby state.
Red flashing	Recoverable error.
Red ON	The device has unrecoverable error. It may need replacing.
Green/Red flashing	The device is in self-test.

**LED MNS: MS/NS Combined**

This LED indicates the MNS status

Color & Status	Description
OFF	<ul style="list-style-type: none"> <li>• The device is not powered.</li> <li>• The device has not completed the duplicate node address test.</li> </ul>
Green flashing	<ul style="list-style-type: none"> <li>• The device is on line and operating in a normal condition, but network connections are not established</li> <li>• The device has passed the duplicate node address test and is on line, but has not established connections to other nodes.</li> <li>• Configuration is missing, incomplete, or incorrect.</li> </ul>
Green ON	<ul style="list-style-type: none"> <li>• The device is on-line and has connections are established.</li> <li>• The device has one or more established connections</li> </ul>
Red flashing	<ul style="list-style-type: none"> <li>• One or more I/O connections timed out.</li> <li>• Recoverable error</li> <li>• Invalid scanner configuration.</li> <li>• External error</li> </ul>
Red ON	<ul style="list-style-type: none"> <li>• The card has an unrecoverable error and may need replacing.</li> <li>• The device has detected error that has rendered it incapable communicating on the network (duplicate node address or bus turned off).</li> </ul>
Green/Red flashing	The device has detected a network access error and is in the communication interruption detected state. The device has then received and accepted an identify communication interruption request-Long protocol message.

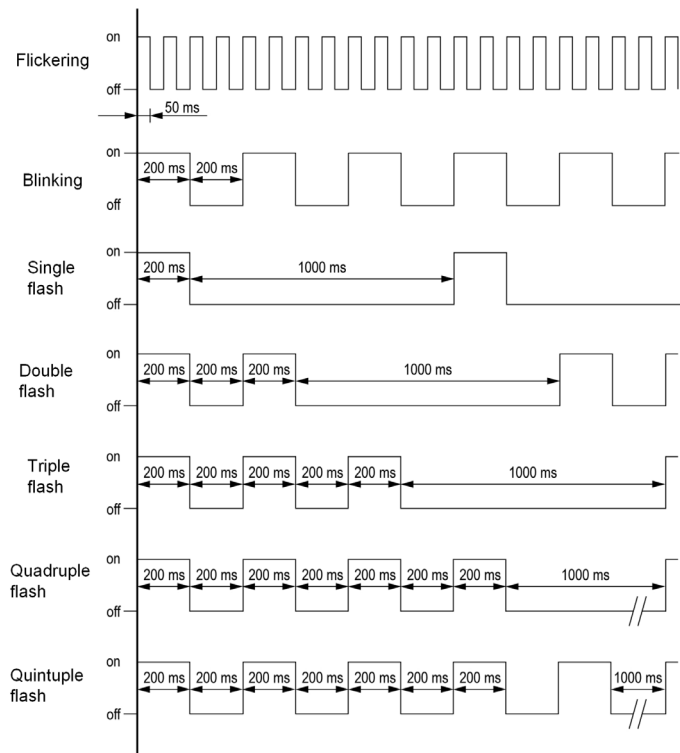

## Connection for Fieldbus Mode

### Description

If the product cannot be addressed via the fieldbus, first check the connections. The product manual contains the technical data of the device and information on network and device installation. Check the following:

- Power connections to the device.
- Fieldbus cable and fieldbus wiring.
- Network connection to the device.

## Monitoring of Communication Channel

### Command and Reference Channels

All the drive command and reference parameters are managed on a channel-by-channel basis.

Parameter Name	Parameter Code				
	Taken Into Account by the Drive	Modbus Serial	CANopen	Fieldbus Module	Ethernet Embedded
Control word	<i>C P d</i>	<i>C P d 1</i>	<i>C P d 2</i>	<i>C P d 3</i>	<i>C P d 5</i>
Extended control word	<i>C P ,</i>	<i>C P , 1</i>	<i>C P , 2</i>	<i>C P , 3</i>	<i>C P , 5</i>
Reference speed (rpm)	<i>L F r d</i>	<i>L F d 1</i>	<i>L F d 2</i>	<i>L F d 3</i>	<i>L F d 5</i>
Reference frequency (0.1 Hz)	<i>L F r</i>	<i>L F r 1</i>	<i>L F r 2</i>	<i>L F r 3</i>	<i>L F r 5</i>
Reference value supplied by PI controller	<i>P , S P</i>	<i>P , r 1</i>	<i>P , r 2</i>	<i>P , r 3</i>	<i>P , r 5</i>
Reference value supplied by analog multiplier function	<i>P F r</i>	<i>P F r 1</i>	<i>P F r 2</i>	<i>P F r 3</i>	<i>P F r 5</i>

### Network Monitoring Criteria

The table provides the details on network monitoring criteria:

Protocol	Criteria	Related detected error
EtherCAT module	0: Not network interruption	<b>[Fieldbus Com Interrupt]</b> <i>C n F</i>
	1: Unspecified interruption	
	11: Link loss (2 ports)	
	23: Invalid Sync Manager configuration	
	25: No valid outputs	
	27: Sync Manager watchdog (1port)	
	29: Invalid Sync Manager output configuration	
	30: Invalid Sync Manager input configuration	
	31: Invalid watchdog configuration	
	36: Invalid input mapping	
	37: Invalid output mapping	
	38: Inconsistent settings	
	43: No valid inputs and outputs	
	44: Sync error	
	80: No access to EEPROM	
	81: EEPROM error	
	96: Generic error	
18: Interface connection timeout	<b>[Internal Link Error]</b> , <i>L F</i>	
19: EEPROM detected error		
21: No memory or Background watchdog or IOC scanner detected error		

### Monitoring of Communication Channels

Communication channels are monitored if they are involved in one of the following parameters:

- The control word (**[Cmd Register]** *C P d*) from the active command channel
- The control word containing the command switch (bit configured on **[Cmd switching]** *C C 5*)

- The control word containing the switch for reference value 1\*1B (bit configured on **[Ref 1B switching]** *r C b*)
- The control word containing the switch for reference value 1\*2 (bit configured on **[Freq Switch Assign]** *r F C*)
- The reference frequency or reference speed (**[Ref Frequency]** *L F r* or *L F r d*: Nominal speed value) from the active channel for reference value
- Summing reference frequency or reference speed (**[Ref Frequency]** *L F r* or *L F r d*: Nominal speed value) 2 (assigned to **[Summing Input 2]** *S A 2*)
- Summing reference frequency or reference speed (**[Ref Frequency]** *L F r* or *L F r d*: Nominal speed value) 3 (assigned to **[Summing Input 3]** *S A 3*)
- Subtracting reference frequency or reference speed (**[Ref Frequency]** *L F r* or *L F r d*: Nominal speed value) 2 (assigned to **[Subtract Ref Freq 2]** *d A 2*)
- Subtracting reference frequency or reference speed (**[Ref Frequency]** *L F r* or *L F r d*: Nominal speed value) 3 (assigned to **[Subtract Ref Freq 3]** *d A 3*)
- The reference value given by the PID controller *P i S P*
- The PID controller feedback (**[AI Virtual 1]** *A i u 1*)
- The multiplication coefficient of the reference values (**[Multiplying coeff.]** *Π F r 2* (assigned to **[Ref Freq 2 Multiply]** *Π A 2*)
- The multiplication coefficient of the reference values (**[Multiplying coeff.]** *Π F r 3* (assigned to **[Ref Freq 3 Multiply]** *Π A 3*)

As soon as one of these parameters has been written once to a communication channel, it activates monitoring for that channel.

If a communication warning is sent (in accordance with the protocol criteria) by a monitored port or fieldbus module, the drive triggers a communication interruption.

The drive reacts according to the communication interruption configuration (operating state Fault, maintenance, fallback, and so on)

If a communication warning occurs on a channel that is not being monitored, the drive does not trigger a communication interruption.

### Enabling of Communication Channels

A communication channel is enabled once all the parameters involved have been written at least one time. The drive is only able to start if all channels involved in command and reference value are enabled.

For example:

A drive in DSP402 profile is connected to an active communication channel.

It is mandatory to write at least 1 time the reference value and the command in order to switch from 4-Switched on to 5-Operation enabled state.

A communication channel is disabled:

- In the event of a communication warning.
- In *forced local mode*.

**NOTE:** On exiting *forced local mode*:

- The drive copies the *run* commands, the direction, and the forced local reference value to the active channel (maintained).
- Monitoring of the active channels for the command and reference value resumes following a time delay **[Time-out forc. local]** *F L o t*.
- Drive control only takes effect once the drive has received the reference value and the command from the active channels.

## Communication Interruption

### Description

DeviceNet errors are indicated by the LED on the DeviceNet module.

In the factory configuration, if DeviceNet is involved in the command or reference, a DeviceNet detected error will trigger a resettable drive error **[Fieldbus Com Interrupt] C n F** or **[External Error] E P F 2** and initiate a freewheel stop.

- Following initialization (power-up), the drive checks that at least one command or reference parameter has been written for the first time by DeviceNet.
- Then, if a DeviceNet detects a communication interruption, the drive will react according to the configuration (detected error, maintain, fallback, so on.).

The response of the drive in the event of a DeviceNet communication interruption can be changed.

- Drive error **[Fieldbus Com Interrupt] C n F** or **[Fieldbus Error] E P F 2** (freewheel stop, stop on ramp, fast stop, or DC injection braking stop)
- No drive error (stop, maintain, fallback)

The **[Fieldbus Com Interrupt] C n F** parameter can be used to obtain more detailed information about the origin of the last **[Fieldbus Com Interrupt] C n F** detected error. It can be accessed on the display terminal only, in the **[Diagnostics] d i A** - menu, **[Diag. data] d d E** - submenu.

This parameter is available in the DeviceNet interface object (64 hex = 100), attribute 4.

The table provides the values of **[Fieldbus Com Interrupt] C n F** parameter:

Value	Description	
0	No error	
1	Fault mode triggered. Force Fault/Trip of the control supervisor object (28 hex = 41), attribute 17 trigger this type of event.	
2	Duplicate node address (MAC ID)	
3	CAN FIFO RX error	These events may be caused by loose or broken cables or by noise
4	CAN FIFO TX error	
5	CAN overrun	
6	CAN transmit error	These events may be caused by loose or broken cables or by noise.
7	CAN bus off	
8	Control time-out.COS, cycling, polling, or explicit messaging restart the timer.The time-out can be configured in the parameter "Expected-packed-rate" of the connection object (5), attribute 9.	
9	Acknowledge error, for COS or cyclic only.The error can be configured in the parameters Acknowledge Timer and Retry Limit of the Acknowledge Handler object, attributes 1 and 2.	
10	Reset DeviceNet	
11	Delete I/O connection	
12	Interruption of network power	
13	Invalid scanner configuration	



## A

### Abbreviations

Req. = Required

Opt. = Optional

## C

### CAN

Controller Area Network is an internally standardized serial bus system

### COB

Communication Object. A unit of transportation in a CAN network. Data must be sent across a CAN Network inside a COB. There are 2048 different COB's in a CAN network. A COB can contain at most 8 bytes of data.

### COB ID

Each COB is uniquely identified in a CAN network by a number called the COB Identifier (COB-ID).

## D

### Display terminal

The display terminal menus are shown in square brackets.

For example: **[Communication]**

The codes are shown in round brackets.

For example: **( C a 1 ) -**

Parameter names are displayed on the display terminal in square brackets.

For example: **[Fallback Speed]**

Parameter codes are displayed in round brackets.

For example: **( L F F )**

### DP

Decentralized Periphery

### DPWS

Device Profile for Web Service

## E

### Error

Discrepancy between a detected (computed, measured, or signaled) value or condition and the specified or theoretically correct value or condition.

### ESM

EtherCAT State Machine

## F

### Factory setting

Default configuration of the product.

### Fault

Fault is an operating state. If the monitoring functions detect an error, a transition to this operating state is triggered, depending on the error class. A "Fault reset" is required to exit this operating state after the cause of the detected error has been removed. Further information can be found in the pertinent standards such as IEC 61800-7, ODVA Common Industrial Protocol (CIP).

**Fault Reset**

A function used to restore the drive to an operational state after a detected error is cleared by removing the cause of the error so that the error is no longer active.

**L****LSB**

Least Significant Byte

**M****MEI**

Modbus Encapsulated Interface

**Monitoring function**

Monitoring functions acquire a value continuously or cyclically (for example, by measuring) in order to check whether it is within permissible limits. Monitoring functions are used for error detection.

**MS0, MS1**

Number of a master in the network.

**MSB**

Most Significant Byte

**N****NMT**

Network Management. One of the service elements of the application layer in the CAN Reference Model. The NMT serves to configure, initialize, and handle detected errors in a CAN network.

**O****OVDA**

Open DeviceNet Vendor Association

**P****Parameter**

Device data and values that can be read and set (to a certain extent) by the user.

**PDO**

Process Data Object

**PELV**

Protective Extra Low Voltage, low voltage with isolation. For more information: IEC 60364-4-41

**PLC**

Programmable logic controller

**PNO**

PROFIBUS Nutzerorganisation e.V. (PROFIBUS User organization).

**Power stage**

The power stage controls the motor. The power stage generates current for controlling the motor.

**Q****QoS**

Quality of Service

**Quick Stop**

The quick Stop function can be used for fast deceleration of a movement as a response to a detected error or via a command.



**R****RPDO**

Receive PDO

**S****SNMP**

Simple Network Management Protocol

**SNTP**

Simple Network Time Protocol

**SYNC**

Synchronization Object

**T****TPDO**

Transmit PDO

**V****VSD**

Variable Speed Drive

**W****Warning**

If the term is used outside the context of safety instructions, a warning alerts to a potential problem that was detected by a monitoring function. A warning does not cause a transition of the operating state.

**Z****Zone of operation**

This term is used in conjunction with the description of specific hazards, and is defined as it is for a **hazard zone** or **danger zone** in the EC Machinery Directive (2006/42/EC) and in ISO 12100-1.