

4-POLE DEFINITE PURPOSE - 600 VAC, 50-60 HZ

FULL LOAD AMPERES CODE (2)	
TYPE	FLA
14	20 FLA
24	25 FLA
34	30 FLA
44	40 FLA *

COIL VOLTAGE CODE (1)	VOLTAGE	
	60 HZ	50 HZ
V14	24	24
V02	120	110
V09	208-240	220
V04	277	-
V06	480	440
V07	600	550

QUICK CONNECT TERMINALS AND
BINDER HEAD SCREWS FOR EASY WIRING.

* = BOX LUGS #14-#4 AWG WIRE SIZE

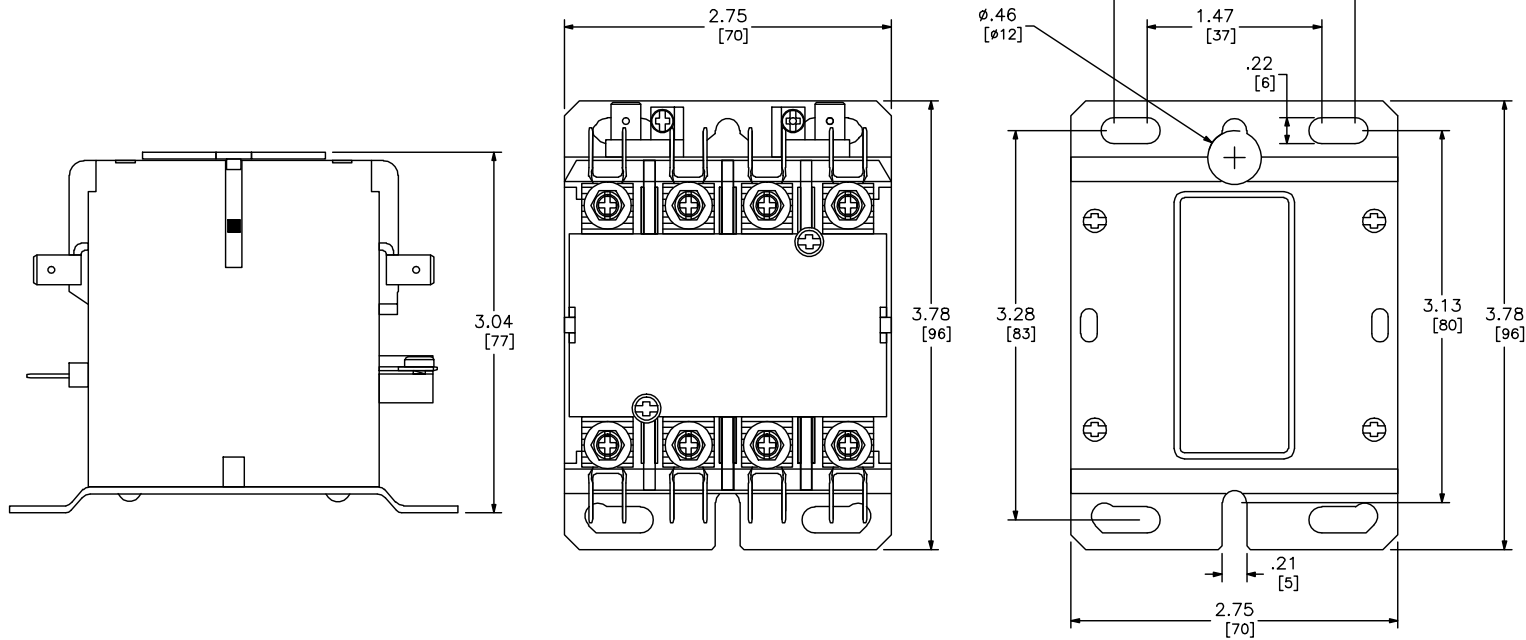

CATALOG NUMBER: 8910-DP(2)(1)
 RATINGS: SEE CHART
 UL FILE/CCN: UL E78351/NLDX2
 CSA FILE/CLASS: CSA 172334/321104
 MEETS STANDARDS: -
 WEIGHT: 1.24 LB
 WIRE SIZE: POWER - #16-#8
 TERMINAL TORQUE: 22LB - IN (20 TO 30 FLA) 40LB - IN (40 FLA)
 MOUNTING HWD.: (4) #10 OR M5 SCREWS

DUAL DIMENSIONS: INCHES
MILLIMETERS

DEFINITE PURPOSE CONTACTOR (4 POLE)
 CLASS 8910 TYPE DPA (2) (1)
 SERIES C



DWG# E0310301-01-C
 No.