

SpaceLogic™ Room Controllers

SE8350 Specification Sheet Low Voltage Fan Coil Unit (FCU) and Zone Control Firmware release version 2.6

Application specific and programmable Room Controller with customizable covers and screen colors. The SpaceLogic SE8350 is a low voltage fan coil and zone Room Controller with a mixed voltage relay pack option. Suitable for commercial and high end hospitality markets.



Product at a glance

The perfect balance between simplicity and sophistication. Select from a wide variety of casings, fascias, and configurable screen colors to match decor. Display your own logo and custom messages on screen to reinforce your brand and provide a more enjoyable occupant experience.

- **Interface:** touch screen interface.
- **Aesthetics:** up to ten selectable screen colors, two color casing options (white and silver) and nine selectable fascias.
- **Flexible:** supports upload of custom standby screen image and Lua scripts.
- **Conformity:** conforms to ASHRAE specifications for Green Building Standards and applicable safety, EMC and radio standards.
- **Protocols:** wired BACnet MS/TP or wireless BACnet IP, Modbus RTU, wireless Zigbee Pro, BACnet/IP and email notification via Wi-Fi (requires a Wi-Fi module).
- **Peripherals:** easy to install Zigbee Pro, CO2 sensor or Wi-Fi plug-in modules.
- **Sensors:** CO2, occupancy, motion, light, temperature, relative humidity and water leak sensors.
- **Integration:** wireless connection to EcoStruxure™ Building Operation (EBO) servers or controllers, and other third party BMS.
- **Automatic Demand Response:** load shedding application for demand response.
- **Power:** Optional VC1300/VC2300 mixed voltage relay pack to interface with line-voltage fan coil or other low voltage application.

Benefits

All models can be equipped with a discrete optional Passive Infrared (PIR) motion sensor. With the embedded motion sensor, the SpaceLogic SE8350 uses advanced occupancy routines to generate energy savings during occupied and unoccupied periods without sacrificing comfort.

- Generate energy savings
- Display custom logo
- Interchange between °C/°F
- Suitable for commercial/hospitality markets
- 22 selectable languages



Schneider
Electric

SE8350 Overview

Introduction

Smart energy management has never been easier than with the SE8350 Room Controllers for fan coil unit applications. Designed for new construction and retrofit projects, the Room Controllers dramatically decrease project delivery costs by reducing installation, configuration and commissioning time. No complex software or tools are required to customize functionality to meet your applications requirements. The Room Controllers provide all the advanced features and monitoring functions required by modern building automation systems in a simple compact enclosure.

Application Specific and Programmable

The SE8350 Room Controllers, part of the SpaceLogic SE8000 family, are both application-specific AND programmable. This enables the modification of pre-configured control sequences, or the creation of entirely new control sequences for fan coil applications. Their configurable control sequences, economizer and scheduler functionalities deliver all the flexibility necessary for optimal indoor air quality applications.

Touch Screen with Customizable User Experience

The touch screen of the SE8350 Room Controller offers a customizable user experience with selection of languages, temperature scales, buttons, and screen colors. Using the 8000 Uploader Tool, it also supports the upload of an image or logo that becomes the default standby screen of the device. Custom messages can also be displayed on-screen using BACnet® objects when the SE8350 is integrated via a BACnet MS/TP, BACnet IP or Modbus RTU system.



Optional Passive Infrared Motion Sensor

All models are available with a discrete optional passive infrared (PIR) motion sensor. With this sensor, the SE8350 Room Controller uses advanced occupancy routines and optional additional Lua scripts to generate automatic energy savings during occupied and unoccupied periods without sacrificing comfort.

Automatic Demand Response

The Automatic Demand Respond (ADR) implements the Load Shedding application compatible with regulations for Occupant Controlled Smart Thermostats. The application requires a BACnet command from interfacing equipment to turn-on and turn-off the Load Shedding feature. Messaging and confirmations are performed by adjoining equipment having Internet connectivity and then providing the Room Controller the BACnet or Modbus command message.

Zigbee Wireless Sensors

The SE8350 Room Controllers support pairing of a number of Zigbee wireless sensors. Facility managers benefit from being able to monitor critical areas and be informed of events of concern in a timely manner which facilitates the maintenance of a safe and efficient operation.

SE8350 Features

Product Highlights

The SE8350 Room Controller has the following high level functionality:

- Customizable color digital touch screen interface with multi-language support
- Fully programmable control sequences using scripting
- On board configuration interface utility
- Configurable fan sequence of operation
- Configurable scheduler
- Humidity sensor with on-board dehumidification strategy
- Optional PIR occupancy sensor
- Advanced occupancy and scheduling functions for commercial and lodging applications
- Optional Zigbee Pro wireless sensors available for windows, doors, motion, temperature, humidity, CO2 and water leak
- Optional or embedded on-board Zigbee Pro module

Communication & Connectivity

The SE8350 Room Controller is ready for networked communication with a Building Management System using BACnet™ (MS/TP on board, or IP via Wi-Fi), Zigbee™ Pro, or Modbus RTU (RS-485), as needed.

Integration to Building Management Systems (BMS)

The SE8350 Room Controller can be seamlessly integrated with the following:

- EcoStruxure™ Building Operation (EBO) and SpaceLogic™ AS-P/AS-B Automation Servers and RP-C/RP-V Room Purpose Controllers
- Most third party BMS
- Direct wired integration to BACnet MS/TP and Modbus
- Zigbee wireless integration to EBO servers or controllers with the SpaceLogic™ Wireless Adapter - Advanced
- Wireless integration to BACnet IP via Wi-Fi (requires a Wi-Fi module)

Custom Match Styling to Decor

- Two color casing options (white and silver)
- LED-backlit LCD touch screen
- 10 color options for LCD screen
- Removable fascia customized with replacement fascia available in nine styles and colors
- 22 selectable languages
- Over 12 screens are available for Commercial and Hospitality use cases



10 selectable screen colors

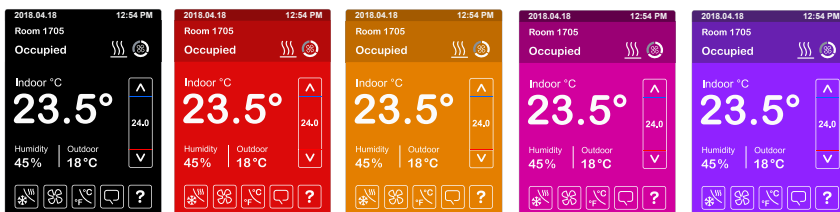

Multiple Fascias

SE8350 Applications

Mixed Voltage Applications

The SE8350 Room Controller can be used for mixed-voltage applications by incorporating a VC1300 (110-120 VAC) or VC2300 (220-240 VAC) mixed-voltage relay. For relay pack features, consult the VC1300/VC2300 specification sheet.

SE8350 as a Zone Controller

The SE8350 Room Controller can also be used as a Zone Controller to control ON/OFF, floating, or 0 to 10 Vdc heating or cooling terminal equipment such as valves, and other end devices.

The following are typical Zone Controller applications:

- 3 speed or ECM fan
- 2 or 4 pipe FCU with reheat
- Fin-tube radiators
- Cabinet heaters
- Radiant panel heaters
- Electric re-heat zones
- Terminal reheat

Typical 2 or 4 Pipe Low Voltage Fan Coil Application

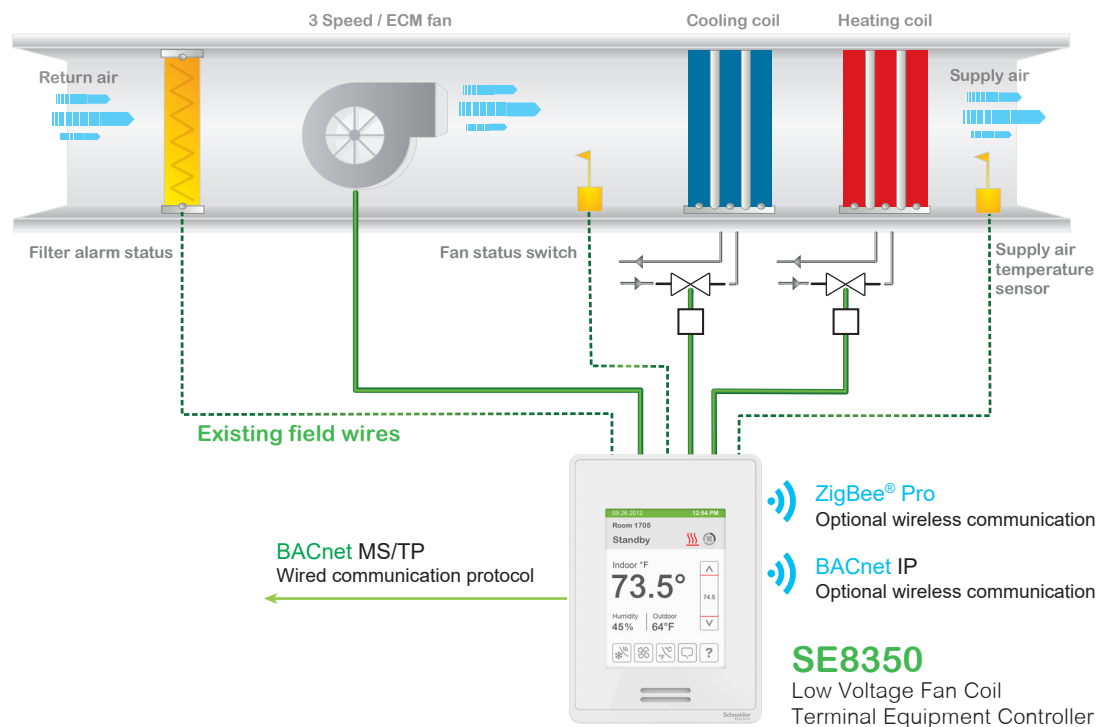

Typical Mixed Voltage Relay Pack Application

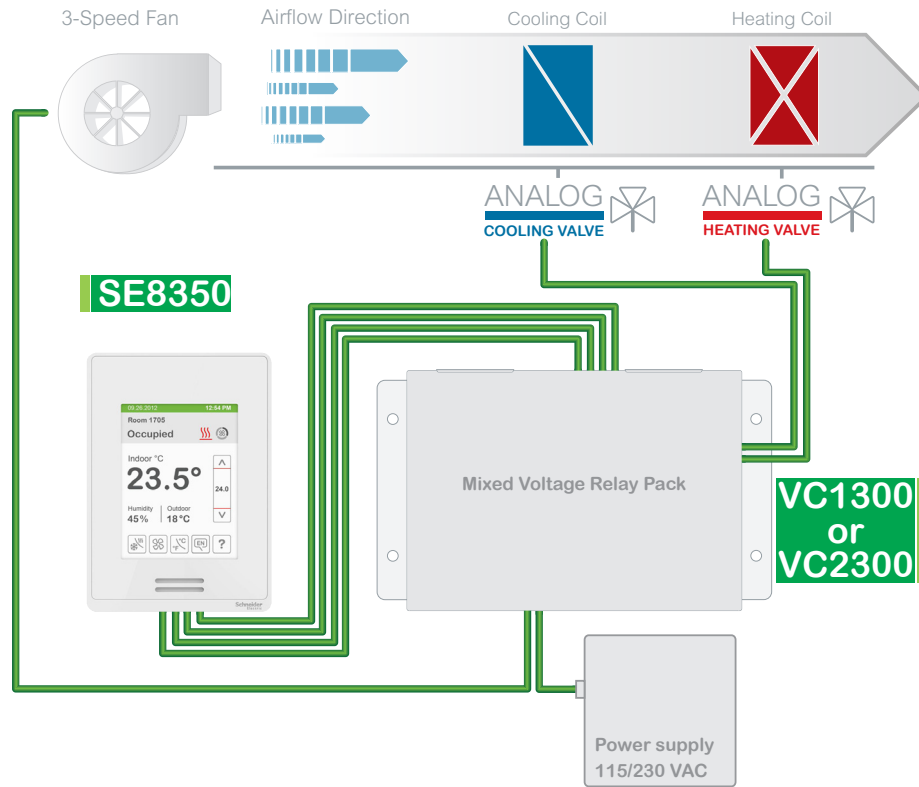

SE8350 Programming

Programming with Lua: HVAC Applications and Beyond

The SE8350 Room Controllers are programmable using the open source programming language Lua. Although building management systems often use open protocols and standards, their program BACnet objects and scripting features remain proprietary and incompatible with third party devices. The SE8350's use of an open language enables operability with all systems.

Programming can be used to go beyond the pre-configured control sequences of the SE8350 to create customized HVAC applications. It can also be used to comply with specific project requirements and manage other applications, such as lighting and other equipment. Using Lua scripts also enables you to take advantage of the extra inputs and outputs of the SE8350 to manage other devices, such as sensors and relays.

Loading Lua via BMS

When integrated into a BACnet MS/TP or IP building management system, the SE8350 allows a program BACnet object to load a Lua script. No special software, license or tool is required.

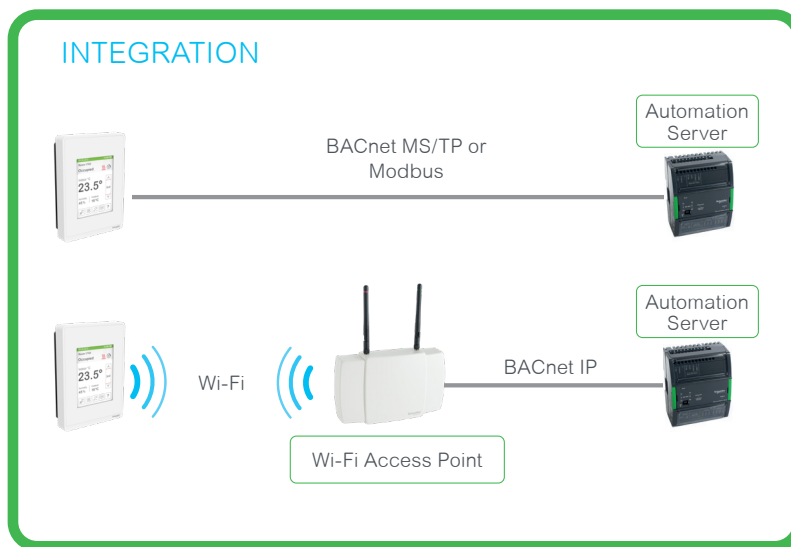

Viewing Objects in EcoStruxure™ Building Operation

All program BACnet objects of the SE8350 Room Controller can easily be viewed through a Building Management System.

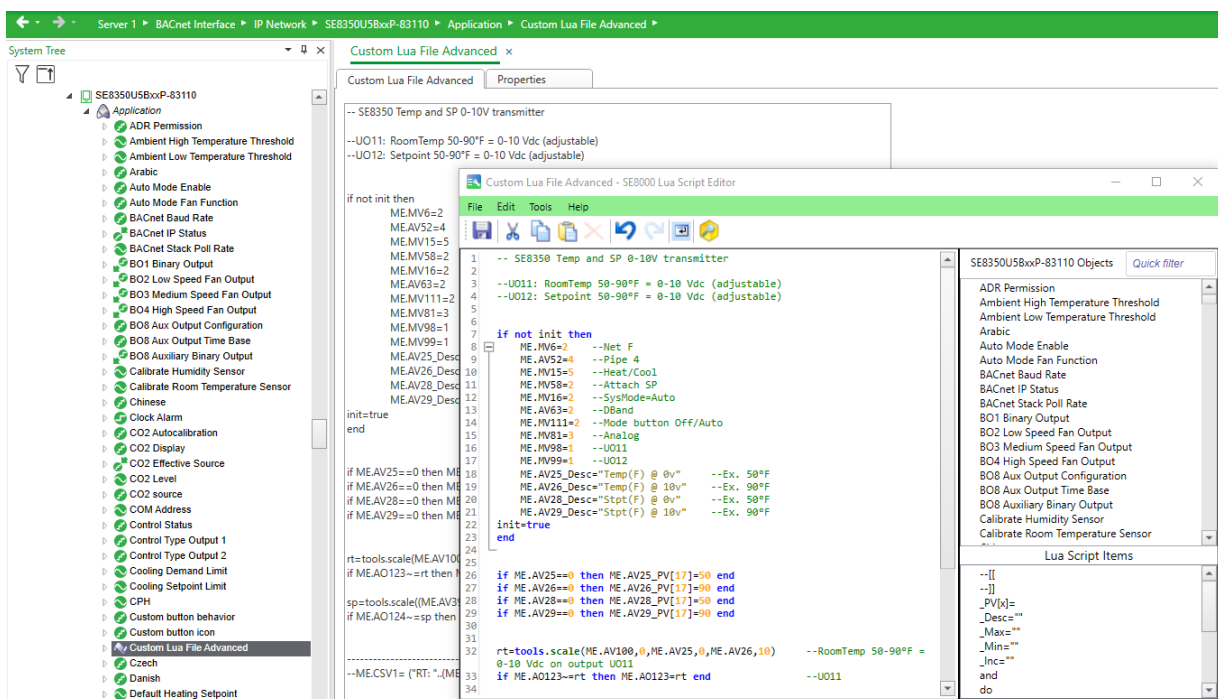

Loading Lua via USB

When there is no BACnet MS/TP, BACnet IP or Modbus integration, a Lua script can be uploaded directly into the SE8350 unit using the 8000 Uploader Tool. In addition to Lua scripts, standby screen images and firmware upgrades can also be loaded into the SE8350 using the 8000 Uploader Tool.

Viewing the Lua Status via SE8350 Touch Screen

As shown on the screen captures below, we can:

- View the first few lines of the Lua script (to facilitate identification of which script is running).
- View the program status and any error information.
- Start or stop the script.
- View the status of 12 objects provided for general use by Lua scripts.

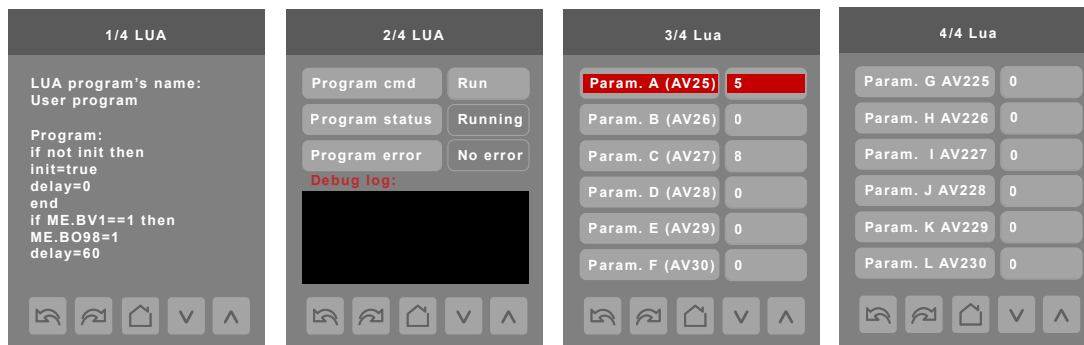

Specifications

Main Specifications

Item	Description
Dimensions	12cm/4.72in (H) x 8.6cm/3.38in (W) x 2.5cm/1in (D)
Power Requirements	Input: 24VAC ±15% recommended, Absolute Max 29.5VAC, 50/60Hz or 24Vdc ±15% Peak device consumption: up to 6VA with CO2 sensor or Wi-Fi module Plus Output Load (max total 94VA) Transformer maximum rating: 100VA, 4.17 A
Output Ratings	5 DO (Electronic Relays): 24VAC or 24Vdc ±15%, 50/60Hz, 1.0 Amp., in-rush = 3.0 Amps (< 100 ms) 4 UO (Electronic Relays or Analog Outputs – Configurable): 0 - 10 Vdc, 5mA maximum, (2 kilo-ohm resistance) Configurable Output Analog/Electronic Relay
Operating Conditions	0 °C to 50 °C (32 °F to 122 °F) 0% to 95% R.H. non-condensing
Storage Conditions	-30 °C to 50 °C (-22 °F to 122 °F) 0% to 95% R.H. non-condensing
Temperature Sensor	Local 10 K NTC type 2 thermistor
Temperature Sensor Resolution	± 0.1 °C (± 0.2 °F)
Temperature Control Accuracy	±0.5 °C (± 0.9 °F) @ 21 °C (70 °F) typical
Humidity Sensor Precision	Reading range from 10-90 % R.H. non-condensing 10 to 20% precision: 10% 20% to 70% precision: 5% 70% to 90% precision: 10%
Humidity Sensor Stability	Less than 0.25 % yearly (typical drift)
Dehumidification Setpoint Range	30% to 95% R.H.
Occ, Unocc and Standby Cooling Setpoint Range	12.0 °C to 37.5 °C (54 °F to 100 °F)
Occ, Unocc and Standby Heating Setpoint Range	4.5 °C to 32 °C (40 °F to 90 °F)
Room and Outdoor Air Temperature Display Range	-40 °C to 50 °C (-40 °F to 122 °F)
Proportional Band for Room Temperature Control	Cooling and Heating: Default: 1.8°C (3.2°F)
Analog Inputs	Modulating 0-10 VDC across UI19, UI24 to Common
Binary Inputs	Dry contact across terminals UI16, UI17 to Common
Remote Temperature Sensor	10 K NTC type 2 thermistor UI20, UI22, UI23
Wire Gauge	Power supply: 16 or 18 gauge Communications: 22 gauge typical, 24 gauge minimum
Shipping Weight	0.34 kg (0.75 lb)

Safety and Certifications

EMC / Safety Standards	Radio Standards (For models with Zigbee Radio)
EMC Directive 2014/30/EU	RED 2014/53/EU
S.I. 2016/1091 – Electromagnetic Compatibility Regulations 2016	S.I. 2017/1206 – Radio Equipment Regulations 2017
FCC 15B Class A	ETSI EN 300 328
ICES-003 Class A	ETSI EN 301 489-1
	ETSI EN 301 489-17
BS/EN 60730-1	FCC Part 15C
BS/EN 60730-2-9	RSS-247
BS/EN 60730-2-13	
UL 60730-1	
CAN/CSA-E60730-1	
UL 60730-2-9	
CAN/CSA-E60730-2-9	
UL 60730-2-13	
CAN/CSA-E60730-2-13	

THIS DEVICE COMPLIES WITH PART 15 OF THE FCC RULES. OPERATION IS SUBJECT TO THE FOLLOWING TWO CONDITIONS: (1) THIS DEVICE MAY NOT CAUSE HARMFUL INTERFERENCE, AND (2) THIS DEVICE MUST ACCEPT ANY INTERFERENCE RECEIVED, INCLUDING INTERFERENCE THAT MAY CAUSE UNDESIRE OPERATION.

THE GRANTEE IS NOT RESPONSIBLE FOR ANY CHANGES OR MODIFICATIONS NOT EXPRESSLY APPROVED BY THE PARTY RESPONSIBLE FOR COMPLIANCE. SUCH MODIFICATIONS COULD VOID THE USER'S AUTHORITY TO OPERATE THE EQUIPMENT.

This equipment has been tested and found to comply with the limits for a Class B digital device, pursuant to Part 15 of the FCC Rules. These limits are designed to provide reasonable protection against harmful interference in a residential installation. This equipment generates uses and can radiate radio frequency energy and, if not installed and used in accordance with the instructions, may cause harmful interference to radio communications. However, there is no guarantee that interference will not occur in a particular installation. If this equipment does cause harmful interference to radio or television reception, which can be determined by turning the equipment off and on, the user is encouraged to try to correct the interference by one of the following measures:

Reorient or relocate the receiving antenna.
Increase the separation between the equipment and receiver.
Connect the equipment into an outlet on a circuit different from that to which the receiver is connected.
Consult the dealer or an experienced radio/TV technician for help.

This device complies with Industry Canada's licence-exempt RSSs. Operation is subject to the following two conditions:

- (1) This device may not cause interference; and
 - (2) This device must accept any interference, including interference that may cause undesired operation of the device.
- In order to comply with FCC/ISED RF Exposure requirements, this device must be installed to provide at least 20 cm separation from the human body at all times.

Le présent appareil est conforme aux CNR d'Industrie Canada applicables aux appareils radio exempts de licence. L'exploitation est autorisée aux deux conditions suivantes :

- 1) l'appareil ne doit pas produire de brouillage;
- 2) l'appareil doit accepter tout brouillage radioélectrique subi, même si le brouillage est susceptible d'en compromettre le fonctionnement.

Afin de se conformer aux exigences d'exposition RF FCC/ISED, cet appareil doit être installé pour fournir au moins 20 cm de séparation du corps humain en tout temps.



Check with your local government for instruction on disposal of this product.



	UK Representative	Manufacturer
	Schneider Electric Limited Stafford Park 5 Telford, TF3 3BL United Kingdom	Schneider Electric Industries SAS 35 rue Joseph Monier Rueil Malmaison 92500 France

Dimensions

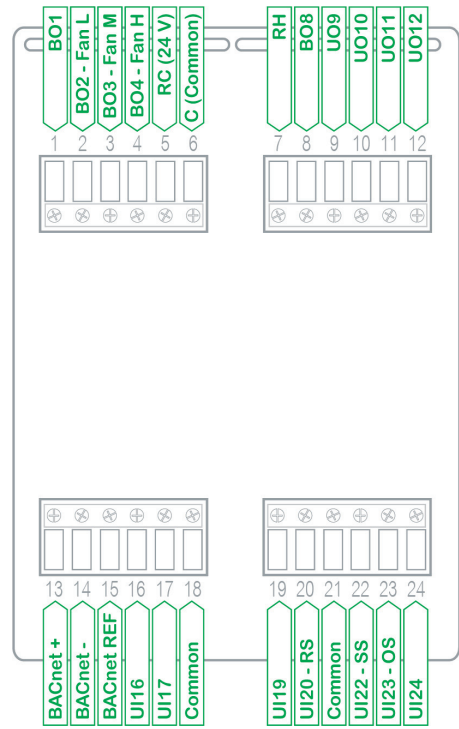
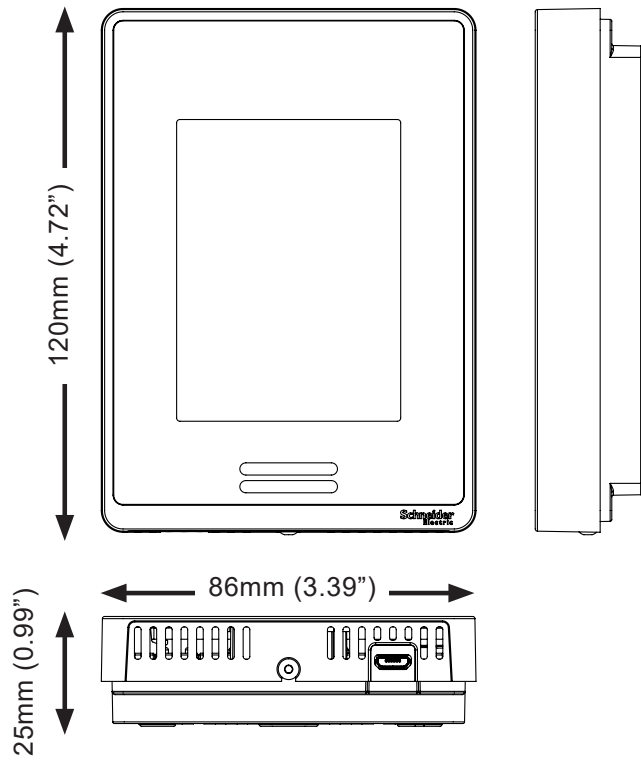

Ordering Information

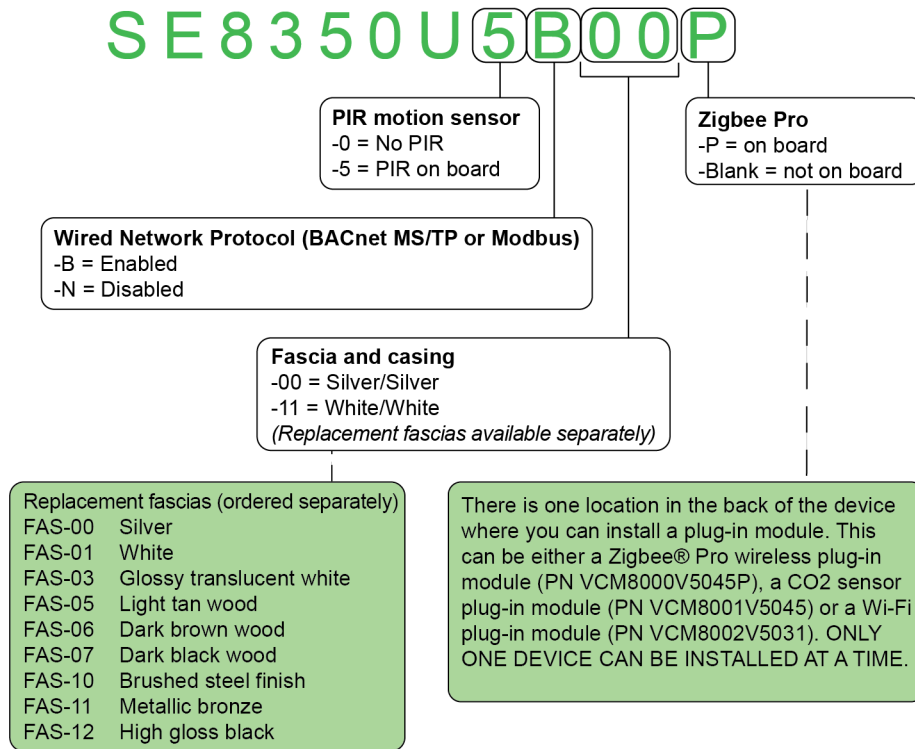

Part numbers

SE8350 part numbers	RH sensor & control	PIR motion sensor	Zigbee built-in	BACnet MS/TP or Modbus	Silver fascia & casing	White fascia & casing
SE8350U0B00	x		*	x	x	
SE8350U5B00	x	x	*	x	x	
SE8350U5B00P	x	x	x	x	x	
SE8350U0B11	x		*	x		x
SE8350U5B11	x	x	*	x		x
SE8350U5B11P	x	x	x	x		x
SE8350U0N11	x		*			x
SE8350U5N11	x	x	*			x

* Note: Zigbee Pro plug-in module is available.

Accessories

Plug-in modules and fascias

Consult their respective data sheets for the latest available part numbers and features.

NOTICE

DISABLED WIRED NETWORK PROTOCOL

The RS-485 transceiver connected to pins 13 and 14 is not installed on Room Controllers with part numbers SE8350U0N11 and SE8350U5N11, thus disabling the wired network protocol (BACnet MS/TP or Modbus). The network screens and the optional Wi-Fi protocol BACnet/IP will still operate normally.

When ordering, make sure the Room Controller specifications comply with your system design.