

PacT Series

ComPacT NS - MicroLogic A and E Trip Units

User Guide

PacT Series offers world-class breakers and switches.

DOCA0218EN-00
01/2022



Legal Information

The Schneider Electric brand and any trademarks of Schneider Electric SE and its subsidiaries referred to in this guide are the property of Schneider Electric SE or its subsidiaries. All other brands may be trademarks of their respective owners.

This guide and its content are protected under applicable copyright laws and furnished for informational use only. No part of this guide may be reproduced or transmitted in any form or by any means (electronic, mechanical, photocopying, recording, or otherwise), for any purpose, without the prior written permission of Schneider Electric.

Schneider Electric does not grant any right or license for commercial use of the guide or its content, except for a non-exclusive and personal license to consult it on an "as is" basis. Schneider Electric products and equipment should be installed, operated, serviced, and maintained only by qualified personnel.

As standards, specifications, and designs change from time to time, information contained in this guide may be subject to change without notice.

To the extent permitted by applicable law, no responsibility or liability is assumed by Schneider Electric and its subsidiaries for any errors or omissions in the informational content of this material or consequences arising out of or resulting from the use of the information contained herein.

As part of a group of responsible, inclusive companies, we are updating our communications that contain non-inclusive terminology. Until we complete this process, however, our content may still contain standardized industry terms that may be deemed inappropriate by our customers.

Table of Contents

Safety Information.....	5
About the Book.....	6
Introduction to MicroLogic A/E Trip Unit.....	7
Presentation.....	8
Description.....	9
Indication LEDs.....	17
Go2SE Landing Page.....	19
Using the MicroLogic A/E Human Machine Interface.....	20
HMI Display Modes.....	21
Quick View Mode for MicroLogic E Trip Unit.....	22
Presentation.....	23
Using Quick View.....	25
Customizing Quick View.....	26
Tree Navigation Mode.....	28
Presentation.....	29
MicroLogic A Menu Display.....	31
MicroLogic E Menu Display.....	32
Displaying Protection Settings.....	34
Displaying and Resetting Total Active Energy (MicroLogic E).....	36
Displaying Trip History (MicroLogic E).....	38
MicroLogic A Settings.....	40
MicroLogic E Settings.....	43
Protection Settings for MicroLogic A/E Trip Unit.....	48
Setting Procedure.....	49
Setting MicroLogic 2.0 A/E Trip Unit.....	50
Setting MicroLogic 5.0 A/E Trip Unit.....	51
Setting MicroLogic 6.0 A/E Trip Unit.....	52
Setting MicroLogic 7.0 A Trip Unit.....	54
Setting the Neutral Protection.....	56
Protection Functions of MicroLogic A/E Trip Unit.....	58
Long-Time Protection.....	59
Short-Time Protection.....	60
Instantaneous Protection.....	61
Ground-Fault Protection on MicroLogic 6.0 A/E Trip Unit.....	62
Earth-Leakage Protection on MicroLogic 7.0 A Trip Unit.....	63
Neutral Protection.....	64
Other Functions of MicroLogic A/E Trip Unit.....	65
Measurements.....	66
Trip History for MicroLogic E Trip Unit.....	69
Communication Function.....	70
Maintenance of the MicroLogic A/E Trip Unit.....	71
Checking and Replacing the Internal Battery.....	72
Testing the Ground-Fault and Earth-Leakage Protection Functions.....	74
Testing the MicroLogic Trip Unit.....	75
Technical Appendix.....	76
Tripping Curves.....	77

Long-Time Rating Plug	79
Zone Selective Interlocking (ZSI)	82
MicroLogic Display	85
Power Supply	86
Thermal Memory	89
Calculating Demand Values (MicroLogic E)	90
Measurement Ranges and Accuracy	92

Safety Information

Important Information

Read these instructions carefully, and look at the equipment to become familiar with the device before trying to install, operate, service, or maintain it. The following special messages may appear throughout this documentation or on the equipment to warn of potential hazards or to call attention to information that clarifies or simplifies a procedure.



The addition of this symbol to a “Danger” or “Warning” safety label indicates that an electrical hazard exists which will result in personal injury if the instructions are not followed.



This is the safety alert symbol. It is used to alert you to potential personal injury hazards. Obey all safety messages that follow this symbol to avoid possible injury or death.

DANGER

DANGER indicates a hazardous situation which, if not avoided, **will result in** death or serious injury.

WARNING

WARNING indicates a hazardous situation which, if not avoided, **could result in** death or serious injury.

CAUTION

CAUTION indicates a hazardous situation which, if not avoided, **could result in** minor or moderate injury.

NOTICE

NOTICE is used to address practices not related to physical injury.

Please Note

Electrical equipment should be installed, operated, serviced, and maintained only by qualified personnel. No responsibility is assumed by Schneider Electric for any consequences arising out of the use of this material.

A qualified person is one who has skills and knowledge related to the construction and operation of electrical equipment and its installation, and has received safety training to recognize and avoid the hazards involved.

About the Book

Document Scope

The aim of this guide is to provide users, installers and maintenance personnel with the technical information needed to operate MicroLogic™ A/E trip units in ComPacT™ NS circuit breakers.

Validity Note

This guide applies to ComPacT NS MicroLogic A/E trip units.

Online Information

The information contained in this guide is likely to be updated at any time. Schneider Electric strongly recommends that you have the most recent and up-to-date version available on www.se.com/ww/en/download.

The technical characteristics of the devices described in this guide also appear online. To access the information online, go to the Schneider Electric home page at www.se.com.

Related Documents

Title of documentation	Reference number
<i>ComPacT NS - Circuit Breakers and Switch-Disconnectors - User Guide</i>	DOCA0221EN
<i>ComPacT NS - Modbus Communication Guide</i>	DOCA0220EN
<i>ComPacT NS630b-1600 - Fixed Circuit Breaker or Switch-Disconnecter - Instruction Sheet</i>	JYT6180003
<i>ComPacT NS630b-1600 - Withdrawable Circuit Breaker or Switch-Disconnecter - Instruction Sheet</i>	JYT6180103
<i>ComPacT NS1600b-3200 - Fixed Circuit Breaker or Switch-Disconnecter - Instruction Sheet</i>	JYT6180203

You can download these technical publications and other technical information from our website at www.se.com/ww/en/download.

Introduction to MicroLogic A/E Trip Unit

What's in This Part

Presentation	8
Description	9
Indication LEDs.....	17
Go2SE Landing Page.....	19

Presentation

PacT Series Master Range

Future-proof your installation with Schneider Electric's low-voltage and medium-voltage PacT Series. Built on legendary Schneider Electric innovation, the PacT Series comprises world-class circuit breakers, switches, residual current devices and fuses, for all standard and specific applications. Experience robust performance with PacT Series within the EcoStruxure-ready switchgear, from 16 to 6300 A in low-voltage and up to 40.5 kV in medium-voltage.

Introduction

ComPacT NS630-3200 circuit breakers are equipped with a MicroLogic trip unit designed to help protect power circuits and connected loads.

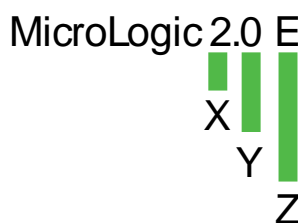

X : Type of protection

- 2 for basic protection
- 5 for selective selection
- 6 for selective + ground-fault protection
- 7 for selective + earth-leakage protection

Y : Version number

Identification of the trip unit generation (0 is the first generation.)

Z : Type of measurement

- A : Ammeter
- E : Energy meter
- P : Power meter
- No indication : No measurements

NOTE: In this guide, A/E signifies A or E when characteristics are common to both MicroLogic A and MicroLogic E trip units.

Range of MicroLogic A/E Trip Units

The following table indicates the standard functions available on ComPacT NS circuit breakers with MicroLogic A/E trip units:

Function	MicroLogic trip unit						
	2.0 A	2.0 E	5.0 A	5.0 E	6.0 A	6.0 E	7.0 A
Long-time overcurrent protection (L)	✓	✓	✓	✓	✓	✓	✓
Short-time overcurrent protection (S)	–	–	✓	✓	✓	✓	✓
Instantaneous overcurrent protection (I)	✓	✓	✓	✓	✓	✓	✓
Ground-fault protection (G)	–	–	–	–	✓	✓	–
Earth-leakage protection (E)	–	–	–	–	–	–	✓
Neutral protection on 4P circuit breaker	✓	✓	✓	✓	✓	✓	✓
Overload LED	✓	✓	✓	✓	✓	✓	✓
Trip cause indicators	✓	✓	✓	✓	✓	✓	✓

Description

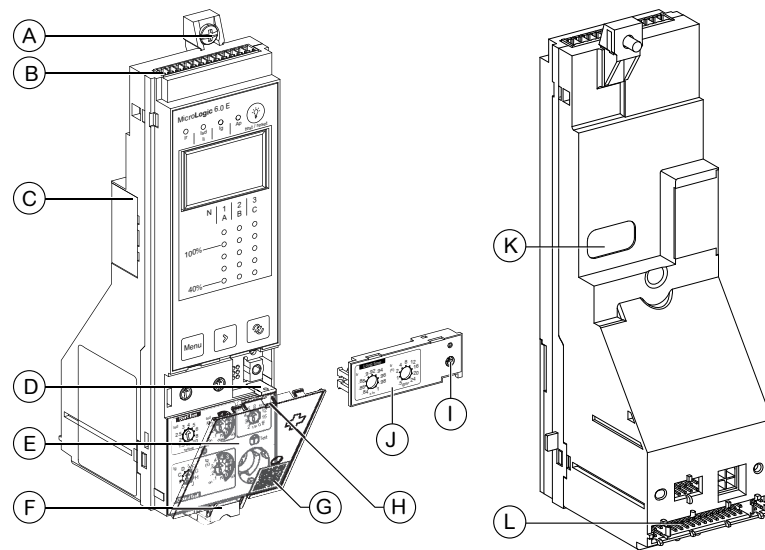

- A. Top fastener
- B. Terminal block for external connections
- C. Battery compartment
- D. Lead-seal fixture for protective cover
- E. Protective cover
- F. Bottom fastener
- G. QR code on protective cover, to access product information
- H. Cover opening point
- I. Screw for long-time rating plug
- J. Long-time rating plug
- K. Infrared link with communication interface
- L. Connection with circuit breaker

MicroLogic 2.0 A Trip Unit

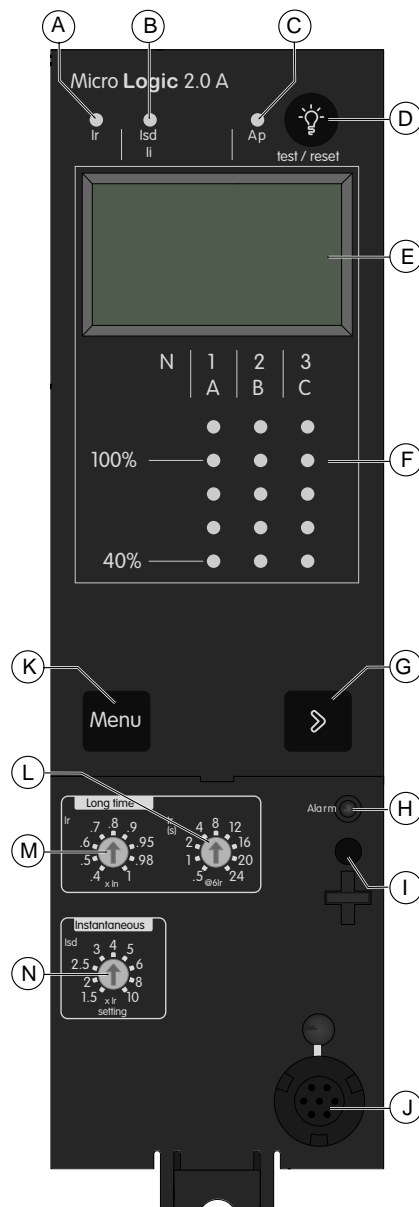

- A. Long-time trip cause indication LED
- B. Instantaneous trip cause indication LED
- C. Auto-protection trip cause indication LED
- D. Fault-trip reset and battery test button
- E. Digital display
- F. Three-phase bargraph and ammeter
- G. Menu scroll button
- H. LED indicating an overload
- I. Screw for long-time rating plug
- J. Test connector
- K. Menu selection button
- L. Long-time time delay tr
- M. Long-time current setting Ir
- N. Instantaneous pickup Isd

MicroLogic 2.0 E Trip Unit

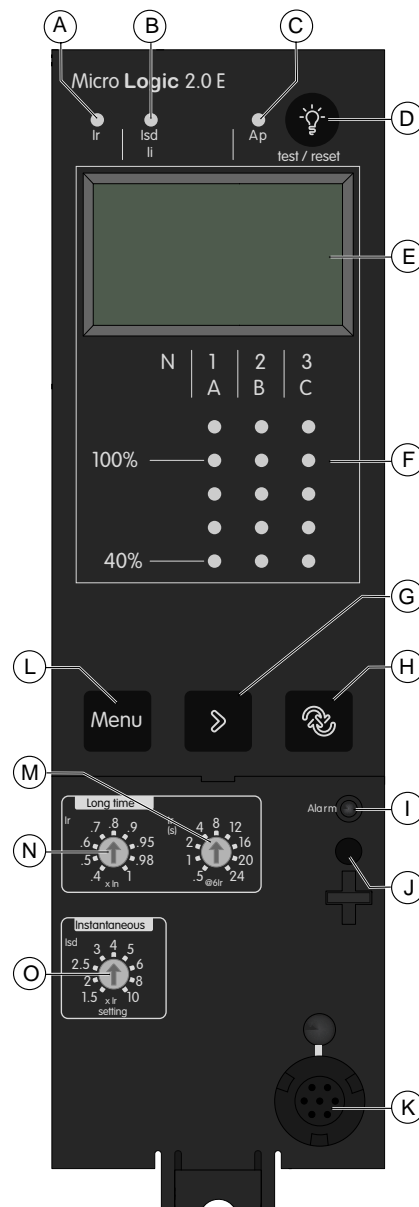

- A. Long-time trip cause indication LED
- B. Instantaneous trip cause indication LED
- C. Auto-protection trip cause indication LED
- D. Fault-trip reset and battery test button
- E. Digital display
- F. Three-phase bargraph and ammeter
- G. Menu scroll button
- H. **Quick View** navigation button
- I. LED indicating an overload
- J. Screw for long-time rating plug
- K. Test connector
- L. Menu selection button
- M. Long-time time delay tr
- N. Long-time current setting Ir
- O. Instantaneous pickup Isd

MicroLogic 5.0 A Trip Unit

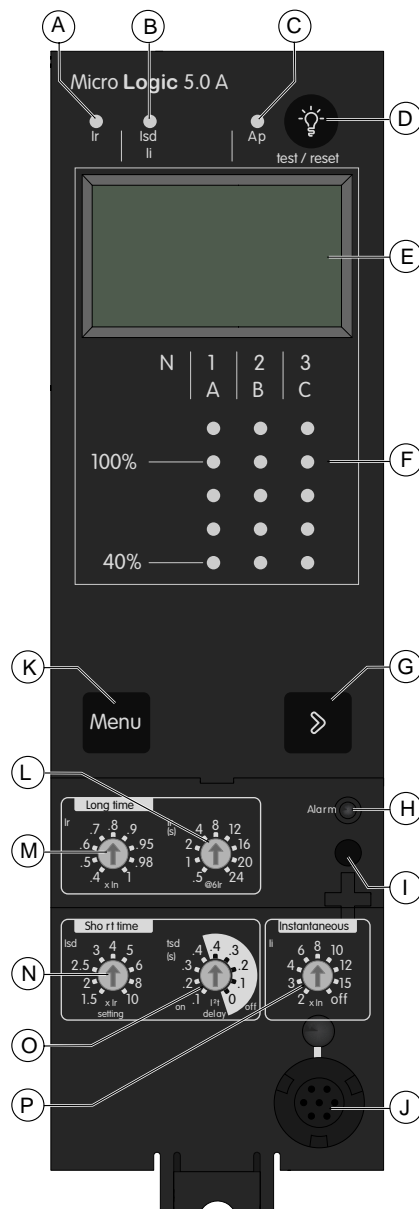

- A. Long-time trip cause indication LED
- B. Short-time or instantaneous trip cause indication LED
- C. Auto-protection trip cause indication LED
- D. Fault-trip reset and battery test button
- E. Digital display
- F. Three-phase bargraph and ammeter
- G. Menu scroll button
- H. LED indicating an overload
- I. Screw for long-time rating plug
- J. Test connector
- K. Menu selection button
- L. Long-time time delay tr
- M. Long-time current setting Ir
- N. Short-time pickup Isd
- O. Short-time time delay tsd
- P. Instantaneous pickup Ii

MicroLogic 5.0 E Trip Unit

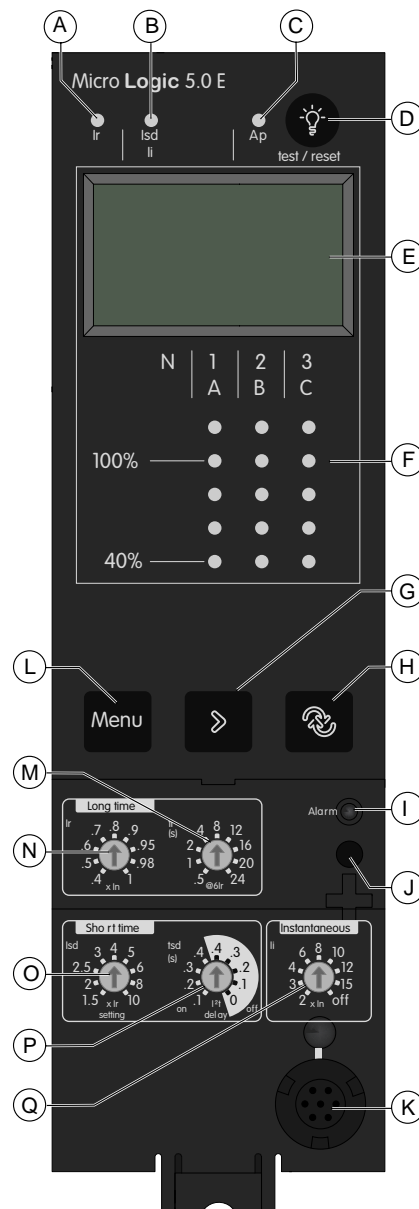

- A. Long-time trip cause indication LED
- B. Short-time or instantaneous trip cause indication LED
- C. Auto-protection trip cause indication LED
- D. Fault-trip reset and battery test button
- E. Digital display
- F. Three-phase bargraph and ammeter
- G. Menu scroll button
- H. **Quick View** navigation button
- I. LED indicating an overload
- J. Screw for long-time rating plug
- K. Test connector
- L. Menu selection button
- M. Long-time time delay tr
- N. Long-time current setting Ir
- O. Short-time pickup Isd
- P. Short-time time delay tsd
- Q. Instantaneous pickup li

MicroLogic 6.0 A Trip Unit

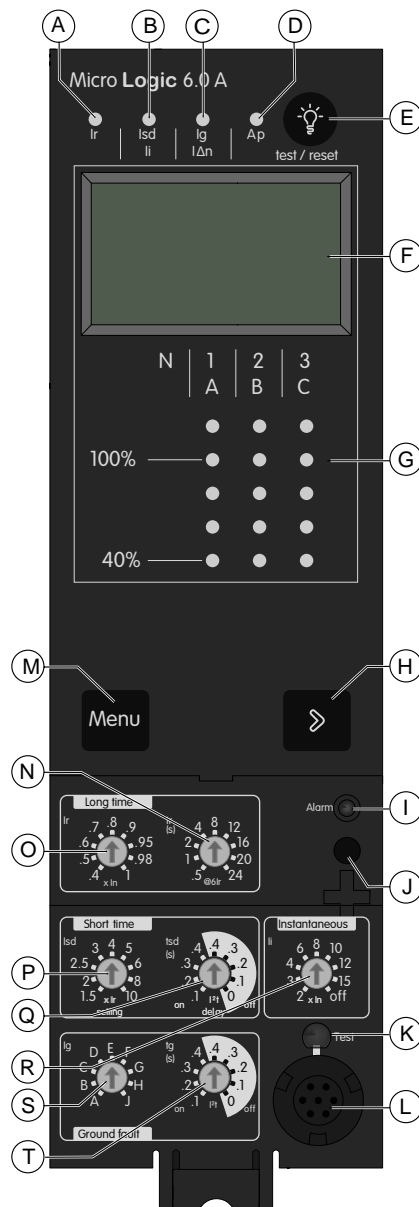

- A. Long-time trip cause indication LED
- B. Short-time or instantaneous trip cause indication LED
- C. Ground-fault trip cause indication LED
- D. Auto-protection trip cause indication LED
- E. Fault-trip reset and battery test button
- F. Digital display
- G. Three-phase bargraph and ammeter
- H. Menu scroll button
- I. LED indicating an overload
- J. Screw for long-time rating plug
- K. Test button for ground-fault and earth-leakage protection
- L. Test connector
- M. Menu selection button
- N. Long-time time delay tr
- O. Long-time current setting Ir
- P. Short-time pickup Isd
- Q. Short-time time delay tsd
- R. Instantaneous pickup li
- S. Ground-fault pickup Ig
- T. Ground-fault time delay tg

MicroLogic 6.0 E Trip Unit

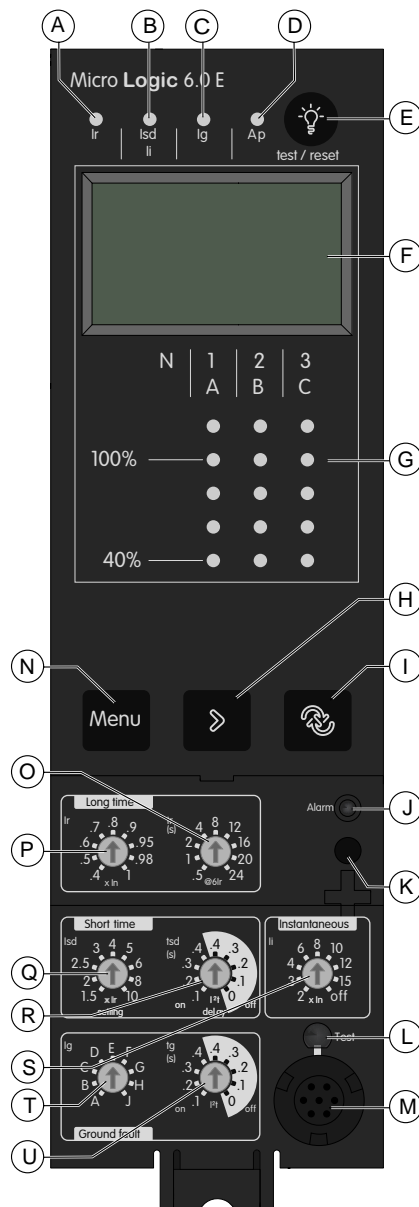

- A. Long-time trip cause indication LED
- B. Short-time or instantaneous trip cause indication LED
- C. Ground-fault trip cause indication LED
- D. Auto-protection trip cause indication LED
- E. Fault-trip reset and battery test button
- F. Digital display
- G. Three-phase bargraph and ammeter
- H. Menu scroll button
- I. **Quick View** navigation button
- J. LED indicating an overload
- K. Screw for long-time rating plug
- L. Test button for ground-fault and earth-leakage protection
- M. Test connector
- N. Menu selection button
- O. Long-time time delay tr
- P. Long-time current setting Ir
- Q. Short-time pickup lsd
- R. Short-time time delay tsd
- S. Instantaneous pickup li
- T. Ground-fault pickup Ig
- U. Ground-fault time delay tg

MicroLogic 7.0 A Trip Unit

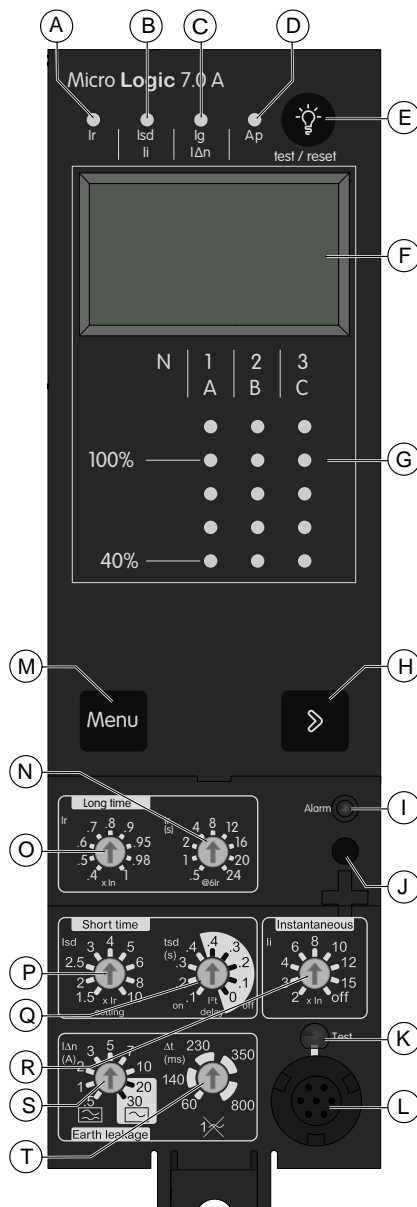

- A. Long-time trip cause indication LED
- B. Short-time or instantaneous trip cause indication LED
- C. Earth-leakage trip cause indication LED
- D. Auto-protection trip cause indication LED
- E. Fault-trip reset and battery test button
- F. Digital display
- G. Three-phase bargraph and ammeter
- H. Menu scroll button
- I. LED indicating an overload
- J. Screw for long-time rating plug
- K. Test button for ground-fault and earth-leakage protection
- L. Test connector
- M. Menu selection button
- N. Long-time time delay t_r
- O. Long-time current setting I_r
- P. Short-time pickup I_{sd}
- Q. Short-time time delay t_{sd}
- R. Instantaneous pickup I_i
- S. Earth-leakage pickup $I_{\Delta n}$
- T. Earth-leakage time delay Δt

Indication LEDs

Overload Indication LED

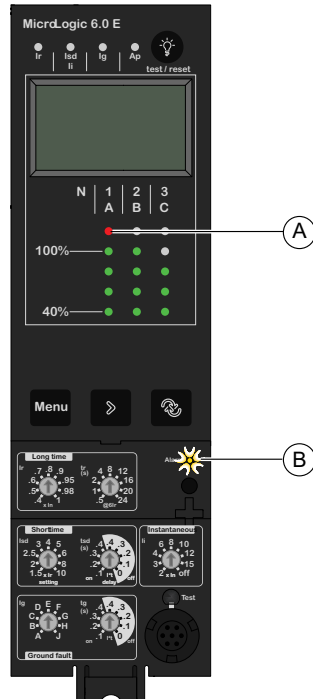

- A. Red LED indicates the phase or phases with overrun
- B. Overload LED: indicates that the long-time current setting I_r has been overrun

Current Indication LEDs

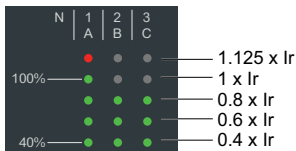



Current indication LEDs on the front of the trip unit continuously display the currents measured on phases 1, 2 and 3 as a percentage of the long-time current setting I_r .

Trip Cause Indication LEDs

The indications of the four trip cause LEDs depend on the type of MicroLogic trip unit.

LED	Description
	MicroLogic 2.0 A/E, 5.0 A/E, 6.0 A/E, 7.0 A: Trip due to long-time protection
	<ul style="list-style-type: none"> • MicroLogic 2.0 A/E: Trip due to instantaneous protection • MicroLogic 5.0 A/E, 6.0 A/E, 7.0 A: Trip due to short-time protection or instantaneous protection

LED	Description
	<ul style="list-style-type: none"> • MicroLogic 2.0 A/E, 5.0 A/E: Not applicable • MicroLogic 6.0 A/E: Trip due to ground-fault protection • MicroLogic 7.0 A: Trip due to earth-leakage protection
	<p>MicroLogic 2.0 A/E, 5.0 A/E, 6.0 A/E, 7.0 A: Trip due to auto-protection.</p> <p>The auto-protection function (excessive temperature or short-circuit higher than circuit-breaker capacity) opens the circuit breaker and turns on the Ap LED.</p> <p>NOTE: If the circuit breaker remains closed and the Ap LED remains on, contact your field service representative.</p>

When activated, a LED remains ON until it is locally reset.

NOTE:

- A number of simultaneous causes may result in tripping. The LED signalling the last trip cause chronologically is the only one to remain ON.
- The battery maintains the trip cause indications. If there are no indications, check the battery.

Resetting Trip Cause Indications

1. Determine why the circuit breaker tripped. The trip cause indication is maintained until it is reset on the trip unit.
2. Press  to reset the trip cause indication LED.

For more information about the procedure for resetting and closing the circuit breaker after a trip, refer to [DOCA0221EN ComPacT NS - Circuit Breakers and Switch-Disconnectors - User Guide](#).

Go2SE Landing Page

Presentation

When the QR code on the front face of a ComPacT NS device is scanned with a smartphone running a QR code reader and connected to the Internet, the Go2SE landing page is displayed.

The landing page displays information about the device and a list of menus.

Landing Page Description

The landing page is accessible from Android and iOS smartphones. It displays the same list of menus with slight differences in presentation.

The following example shows the landing page displayed on an Android smartphone:

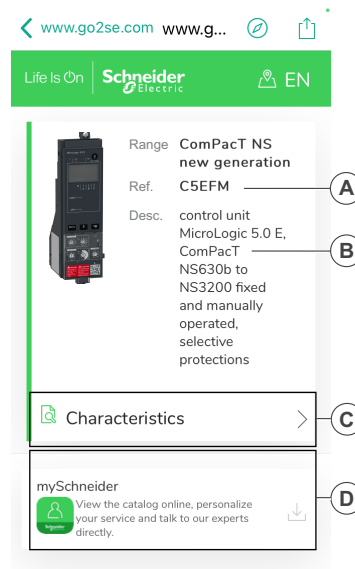

- A. Commercial reference of MicroLogic trip unit
- B. Type of MicroLogic trip unit
- C. Landing page menus. See the following menu descriptions for details.
- D. Downloadable applications

Characteristics

Selecting this menu gives access to a product datasheet with detailed information about the MicroLogic trip unit.

Documentation

Selecting this menu gives access to the ComPacT NS technical publications.

mySchneider App

Selecting this application gives access to the Schneider Electric customer care mobile application **mySchneider** app that can be downloaded on Android and iOS smartphones. For smartphone compatibility, check on your application store. The customer care application offers self-service instructions and easy access to expert support and information.

Using the MicroLogic A/E Human Machine Interface

What's in This Part

HMI Display Modes	21
Quick View Mode for MicroLogic E Trip Unit	22
Tree Navigation Mode	28

HMI Display Modes

Definitions

- MicroLogic A trip unit has a single display mode: Tree Navigation mode to access data through a menu structure.
- MicroLogic E trip unit has two display modes:
 - Tree Navigation mode to access all data through a menu structure
 - Quick View mode to display a selection of data

Tree Navigation Mode

In Tree Navigation display mode, use the buttons below the display screen to navigate in the menu structure. Tree Navigation display mode presents a single network of menus, with monitoring values and editable configuration settings.

Refer to *Navigating Using the Keypad Buttons*, page 30 for more information about how to use the keypad buttons to:

- Navigate the menu structure
- Access and edit settings

For more information about the menu structure and settings, refer to *Tree Navigation Mode*, page 28.

Quick View Mode

MicroLogic E trip unit also offers a Quick View mode. Quick View mode displays up to 10 screens automatically one after the other, with a configurable time delay. An override function is available to allow manual scrolling.

Quick View is the factory-set display mode for MicroLogic E trip unit.

You can modify the Quick View screens defined in the default configuration.

Quick View Mode for MicroLogic E Trip Unit

What's in This Chapter

Presentation	23
Using Quick View	25
Customizing Quick View	26

Presentation

Quick View on MicroLogic E trip units allows the operator to quickly view the most important electrical measurements (currents, voltages, active power, energy) without having to touch the trip unit keypad.

The screens automatically scroll in a circular manner so that the operator can view all the main electrical measurements one after another.

The current bargraph and overload LED remain visible at all times in Quick View mode.

Quick View Screen Descriptions

Quick View can be used to display the screens defined in:

- The factory configuration
- A custom configuration

Screens Defined in the Factory Configuration

MicroLogic E trip units come with a factory Quick View configuration including the following 9 screens, displayed in the indicated order:

1. Current of phase 1/A
2. Current of phase 2/B
3. Current of phase 3/C
4. Voltage: phase-to-neutral (V1N) or phase-to-phase (V12)
5. Voltage: phase-to-neutral (V2N) or phase-to-phase (V23)
6. Voltage: phase-to-neutral (V3N) or phase-to-phase (V31)
7. Total active power
8. Active energy: whole number part (up to 6 digits) in MWh
9. Active energy: last digit of whole number part plus 3 digits of decimal part

For more information about defining the screens to be displayed in Quick View, refer to *Customizing Quick View*, page 26.

Each screen is displayed for 2 s before being replaced by the next in the list. This duration can be adjusted from 1 s to 9 s in 1 s steps. For more information, refer to *Measurement Settings*, page 43.

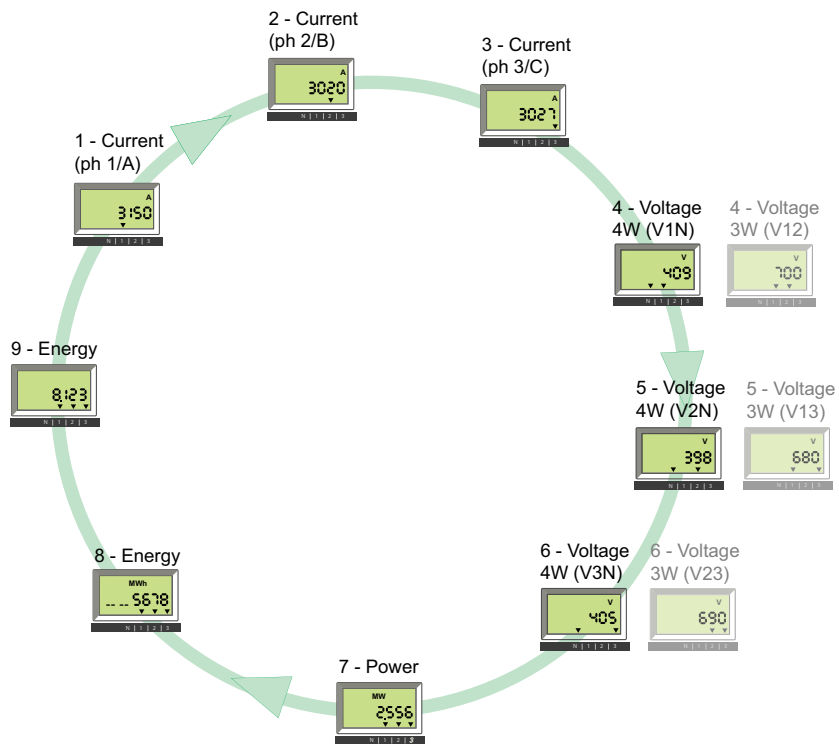

Using Quick View

Activating and Deactivating Quick View

- When energized for the first time, the MicroLogic E trip unit automatically activates Quick View and scrolls through the factory-configured screens.
- Press  briefly (<1 s) to activate the classical tree navigation mode. Press again briefly (<1 s) to return to Quick View mode.
- In both Tree Navigation and Quick View modes, the first screen displayed is screen 1, but in tree navigation mode, finally the screen changes to display the instantaneous current of the most heavily loaded phase.

Manual Control of Quick View Scrolling

Automatic scrolling of Quick View screens can be paused, for example to display a screen for more than 2 s in order to make a note of measurements.



Press briefly (< 1 s)

Stops scrolling and displays the present screen for 20 s if no other action is taken.

It is then possible to manually scroll through each Quick View screen one after the other.

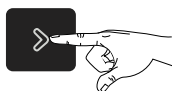

Press briefly (< 1 s)

Displays the next screen for 20 s if no other action is taken.

Returning to Automatic Scrolling

After a period of 20 s with no action, automatic scrolling is reactivated.

Events Causing the Interruption of Automatic Scrolling

Automatic scrolling of Quick View screens is also interrupted by the following events:

- Tripping (interrupted until the trip is reset by pressing )
- Change in a protection setting
- Battery test (while the test button is pressed).

Customizing Quick View

Custom Quick View Configuration



The Quick View factory configuration includes the nine screens presented in the detailed topic, page 23.

It is possible to change some or all of the screens of the factory configuration, up to a maximum of ten screens.

If all Quick View screens are removed, pressing  briefly will have no effect. The display remains in Tree Navigation mode.

Removing a Screen

Follow this procedure to remove a screen from Quick View:

1. Make sure you are in manual control of the Quick View mode, and if necessary, press  briefly (< 1 s) to activate automatic scrolling and then press  briefly (< 1 s) to activate the manual control of the Quick View mode.
2. When the screen to be removed appears, press and hold  (> 4 s).
3. When the message **OK dEL** is displayed, the screen has been removed.

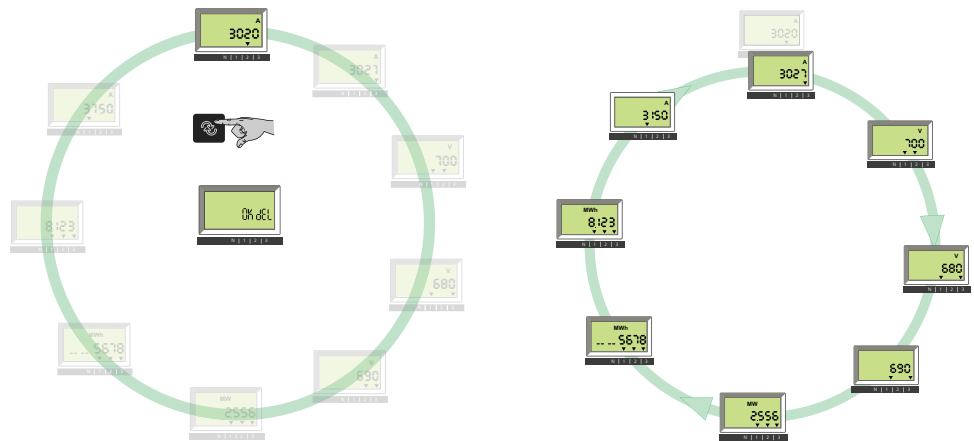

Adding a Screen

Follow this procedure to add a screen (selected from the navigation tree):

1. Access Tree Navigation mode.
2. In this mode, display the screen you want to add, as described in Tree Navigation, page 28.
3. When the selected screen is displayed, press and hold  (> 4 s).
4. When the message **OK Add** is displayed, the screen has been added to the Quick View configuration. It is placed in the last Quick View position.

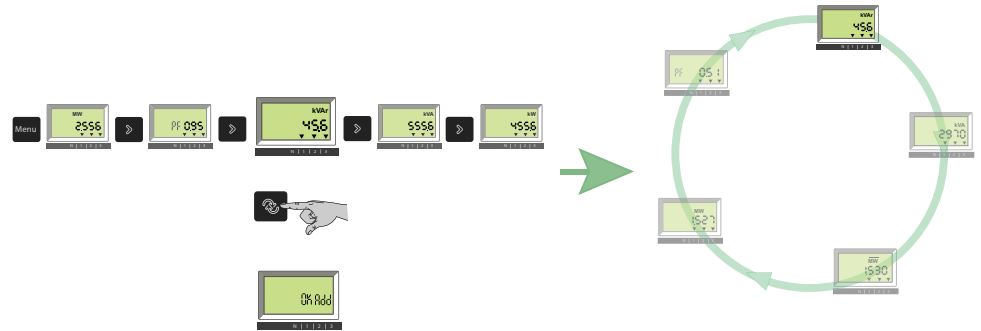

NOTE: If you try to add a screen to an existing configuration that already has ten screens, the message **QV full** is displayed.

Tree Navigation Mode

What's in This Chapter

Presentation	29
MicroLogic A Menu Display	31
MicroLogic E Menu Display	32
Displaying Protection Settings	34
Resetting Current Maximeters	35
Displaying and Resetting Total Active Energy (MicroLogic E)	36
Displaying Trip History (MicroLogic E)	38
MicroLogic A Settings	40
MicroLogic E Settings	43

Presentation

Tree Navigation

Two navigation trees are provided for each MicroLogic trip unit:

- A display tree to view the main values and settings of the trip unit
- A setting tree to modify the settings.

Each tree is divided up into several branches.

Each branch provides access to values or settings that depend on the type of MicroLogic trip unit, for example:

- Measurements (instantaneous current, demand current, maximum instantaneous current, voltage, power, energy).
- Trip history
- Protection setting display
- Settings (for modification of communication, measurement, or output parameters).

For more information about the tree branches:

- For MicroLogic A, refer to MicroLogic A Menu Display, page 31.
- For MicroLogic E, refer to MicroLogic E Menu Display, page 32.



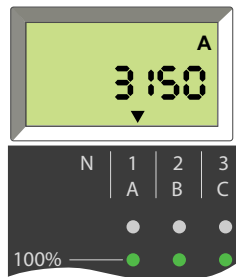

Default Screen

The default screen displays the instantaneous current of the most heavily loaded phase.

Example: Phase 1 is the most heavily loaded.



Navigating with the Keypad Buttons

Button	Description
	Press the menu button to: <ul style="list-style-type: none"> • Scroll through the different branches of a tree. • Return to the instantaneous I1 current screen of the Display tree from the last branch of a tree. • Validate and lock a two-digit setting (MicroLogic E).
	<ul style="list-style-type: none"> • Press briefly the arrow button (< 1 s) to scroll through the different screens of a branch. • Press and hold the arrow button (> 4 s) to reset maximum values or to save settings.
	Press the menu and arrow buttons simultaneously to enter the Setting tree from any screen of the Display tree. Press and hold (> 4 s).
 (MicroLogic E)	Press this button to <ul style="list-style-type: none"> • Change from Tree navigation mode to Quick View mode. • Unlock and access locked settings. • Scroll through setting parameters.

If no key is pressed for a few seconds, the default screen is displayed.

Screen Information

The positions of the downward arrows (one, two, or three arrows) under the information displayed on the screen indicate the phases concerned, as shown for example in the screens below.

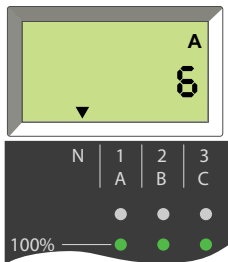

6 A current in the neutral (arrow above the N).

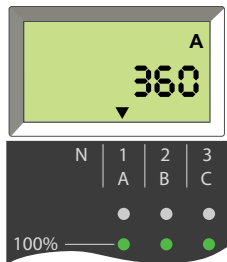

360 A current in phase 1/A (arrow above 1/A).



380 V phase-to-phase voltage between phases 1/A and 2/B (arrows above 1/A and 2/B).

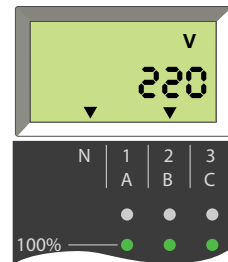

220 V phase-to-neutral voltage between phase 2/B and neutral (arrows above N and 2/B).

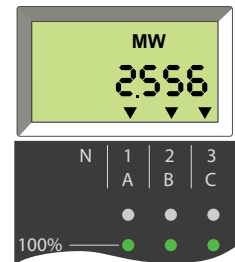

2.556 MW total active power of the 3 phases (arrows above the 3 phases).

MicroLogic A Menu Display

The MicroLogic A navigation tree is organized in the following branches:

- Display
 - Metering
 - Protection settings
- Settings
 - Communication settings

The following table shows the screens of the MicroLogic A display tree.

Display tree branches	Screens
Default screen	Instantaneous current of the most heavily loaded phase
Instantaneous currents	<ul style="list-style-type: none"> • I1: Instantaneous current on phase 1 • I2: Instantaneous current on phase 2 • I3: Instantaneous current on phase 3 • IN: Instantaneous current on neutral ¹ • I_g: Instantaneous ground-fault current (MicroLogic 6.0 A) • I_{Δn}: Instantaneous earth-leakage current (MicroLogic 7.0 A)
Instantaneous current maximeters For information on resetting current maximeters, refer to the detailed topic, page 36.	<ul style="list-style-type: none"> • I1 max: Maximum instantaneous current on phase 1 • I2 max: Maximum instantaneous current on phase 2 • I3 max: Maximum instantaneous current on phase 3 • IN max: Maximum instantaneous current on neutral ¹ • I_g max: Maximum instantaneous ground-fault current (MicroLogic 6.0 A) • I_{Δn} max: Maximum instantaneous earth-leakage current (MicroLogic 7.0 A)
Protection settings	The protection settings displayed depend on the model of the MicroLogic A trip unit. For more information, refer to Displaying Protection Settings , page 34.
(1) Four-pole circuit breakers and three-pole circuit breakers with external neutral sensor.	

The following table shows the screens of the MicroLogic A setting tree.

Setting tree branches	Screens
Communication settings, page 40	<ul style="list-style-type: none"> • Modbus address • Baud rate • Parity • Language

MicroLogic E Menu Display

The MicroLogic E navigation tree is organized in the following branches:

- Display
 - Metering (instantaneous and demand current, voltage, power, active energy)
 - Trip history
 - Protection settings
- Settings
 - Communication settings
 - Measurement settings
 - Output settings
 - Software version















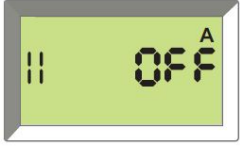

The following table shows the screens of the MicroLogic E display tree.

Display tree branches	Screens
Default screen	Instantaneous current of the most heavily loaded phase
Instantaneous and demand currents	<ul style="list-style-type: none"> • I1: Instantaneous current on phase 1 • I2: Instantaneous current on phase 2 • I3: Instantaneous current on phase 3 • IN: Instantaneous current on neutral ¹ • Ig: Instantaneous ground-fault current (MicroLogic 6.0 E) • $\overline{I1}$: Demand current on phase 1 • $\overline{I2}$: Demand current on phase 2 • $\overline{I3}$: Demand current on phase 3 • \overline{IN}: Demand current on neutral ¹
Instantaneous current maximeters For more information on resetting current maximeters, refer to the detailed topic, page 35.	<ul style="list-style-type: none"> • I1 max: Maximum instantaneous current on phase 1 • I2 max: Maximum instantaneous current on phase 2 • I3 max: Maximum instantaneous current on phase 3 • IN max: Maximum instantaneous current on neutral ¹ • Ig max: Maximum instantaneous ground-fault current (MicroLogic 6.0 E)
Voltages	<ul style="list-style-type: none"> • V1N: Phase-to-neutral voltage (4-wire systems) • V2N: Phase-to-neutral voltage (4-wire systems) • V3N: Phase-to-neutral voltage (4-wire systems) • V12: Phase-to-phase voltage • V23: Phase-to-phase voltage • V31: Phase-to-phase voltage
Power For more information on setting the power sign, refer to the detailed topic, page 43.	<ul style="list-style-type: none"> • P: Instantaneous active power • PF: Power factor • Q: Instantaneous reactive power • S: Instantaneous apparent power • \overline{P}: Demand active power <p>Active power is displayed positively or negatively according to the parameter Power sign.</p>
Active energy For more information on displaying and resetting active energy, refer to the detailed topic, page 36.	<p>Ep is displayed in MWh on one or two screens.</p> <ul style="list-style-type: none"> • Active energy (whole number part) • Active energy (decimal part - if applicable)
Trip history, page 38	The trip history displays the list of the last ten trips.
Protection settings	The protection settings displayed depend on the model of the MicroLogic E trip unit. For more information, refer to Displaying Protection Settings, page 34.
(1) Four-pole circuit breakers and three-pole circuit breakers with external neutral sensor.	

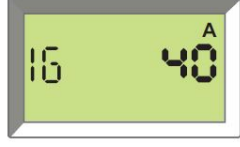
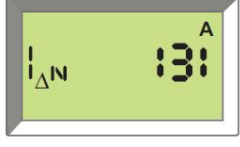
The following table shows the screens of the MicroLogic E setting tree.

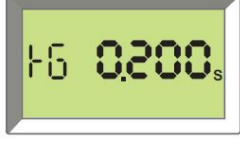
Setting tree branches	Screens
Communication Settings, page 43	<ul style="list-style-type: none">• Modbus address• Baud rate• Parity• Language
Measurement Settings, page 43	<ul style="list-style-type: none">• Interval (window) for demand power calculation• Interval (window) for demand current calculation• Type of network (3-wire or 4-wire) and number of circuit breaker poles (CTs).• Power sign• Quick View display duration
Software version	SW: software version currently installed

Displaying Protection Settings

Protection settings	Availability per MicroLogic trip unit type				Action	Setting display (examples shown are MicroLogic P screens)
	2.0 A 2.0 E	5.0 A 5.0 E	6.0 A 6.0 E	7.0 A		
Long-time current setting I_R	✓	✓	✓	✓	Press  to select Settings menu. The I_R value is displayed first.	
Long-time time delay t_R	✓	✓	✓	✓	Press  to display t_R value.	
Short-time pickup I_{sd}	–	✓	✓	✓	Press  to go on to the short-time I_{sd} value.	
Short-time time delay t_{sd}	–	✓	✓	✓	Press  to go on to the t_{sd} value.	
Instantaneous pickup I_i	–	✓	✓	✓	Press  to go on to the instantaneous I_i value.	
Ground-fault pickup I_g	–	–	✓	–	Press  to go on to the I_g value or...	
Earth-leakage pickup $I_{\Delta n}$	–	–	–	✓	...the $I_{\Delta n}$ value.	
Ground-fault time delay t_g	–	–	✓	–	Press  to go on to the t_g value or...	
Earth-leakage time delay Δt	–	–	–	✓	...the Δt value.	
					Press  to return to the beginning of the menu.	

Resetting Current Maximeters

1. Select the maximum current value to be reset (for example, I2 max.) by pressing  as many times as required to access the I2 max. screen.



2. Reset by pressing and holding  down for 3 to 4 seconds. The old value changes to the present value (the new maximum).



3. Select another value of current to reset or return to the main menu by pressing  as many times as required to select another maximum value to reset or return to the main menu.

Displaying and Resetting Total Active Energy (MicroLogic E)

Displaying Total Active Energy

The total active energy (E_p) consumed since MicroLogic E energizing is displayed on one or two screens:

- The first screen displays the whole number part of total energy in MWh
- The second screen displays the decimal part of total energy in MWh.

Example: display of $E_p = 26.233$ MWh (26233 kWh)

Display of whole number part of total energy in MWh (up to 6 digits)

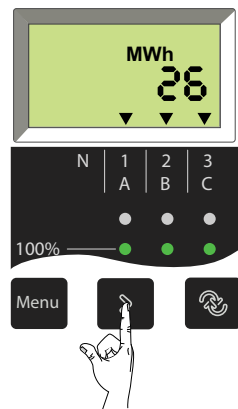

Press  to go to screen for the decimal part.

Display of decimal part of total energy in MWh (up to 3 digits after the decimal preceded by the last digit of the whole number part)





Press  to go to screen for the whole number part.

The total active energy (E_p) is calculated and displayed positively whatever the value of the parameter power sign. The maximum total active energy that can be displayed is 999 999 999 MWh. If the total active energy keeps increasing, the value displayed remains at 999 999 999 MWh.

Resetting Total Active Energy

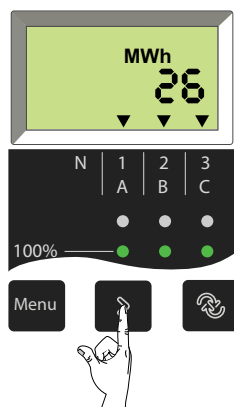
1. Select the active energy screen by pressing  as many times as required to access the total active energy screen (displaying the whole number part of the total active energy).



2. Reset by pressing and holding  down for 3 to 4 seconds. The old value changes to the new value (starting at 0) when the button is released.

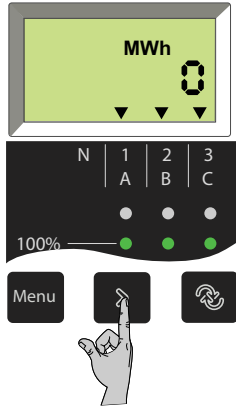

3. Press  to return to the main menu.

Displaying Trip History (MicroLogic E)

Introduction

The MicroLogic E trip history displays the list of the last 10 trips.

For each trip, the following indications are recorded and displayed on three screens:

- Tripping cause
- Date of trip
- Time of trip

Example: Display for the first (most recent) trip of the five trips recorded in the trip history.

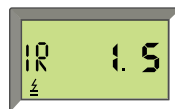

Ir: tripping cause

I: symbol indicating trip history display

1: trip number (1 being the most recent)

5: total number of trips recorded

To display trip history:

1. Press  to scroll through the three screens of each trip.

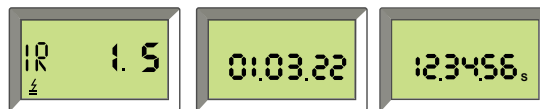



In this example, the most recent trip recorded in the trip history is a trip caused by the long-time protection on 3rd January 2022 at 12.34 and 56 s.

2. Press  again to see the next trip in the history.

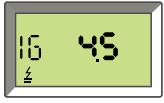

List of Trip Screens for Possible Causes

Cause	Description	Screen display
Ir trip	Long-time protection	
Isd trip	Short-time protection	
Ii trip	Instantaneous protection	
Ig trip	Ground-fault protection	
Ap trip	Auto-protection	

NOTE: Instantaneous protection trips (Ii) are indicated on the trip history screen in the same way as short-time protection trips (Isd). Both are caused by short-circuits.

Trip Date and Time

For each trip history screen, MicroLogic E trip unit will display the date and time of the trip. Every time the 24 Vdc control voltage is energized, date and time restart at January 1st 2000.

The setting of the MicroLogic E trip unit date and time requires the communication option. MicroLogic E date and time can be set manually in one of the following ways:

- By using the FDM121 Front Display Module
- By sending a setting command using the communication network

MicroLogic E date and time can be automatically updated:

- With the IFE Ethernet interface with the following conditions:
 - Ethernet interface is configured in SNTP mode.
 - Ethernet interface receives an update date and time request from the SNTP server.
- With the IFM Modbus-SL interface receiving an update date and time request from the SNTP server





MicroLogic A Settings

Communication Settings

When the BCM ULP communication module is installed, the communication settings must be set.



The communication parameters have default values that can or must be changed according to the needs of the installation or users.

The following table lists the communication parameters and indicates their possible values.

Parameter	Definition	Format (X=digit)	Default value (units)	Default value screen	Possible values
Modbus address	Unique Modbus address of MicroLogic A trip unit on the Modbus network to which it is connected.	XX	47		1 to 47
Baud rate	Number of kbits/s (kbauds) exchanged on the Modbus network. It must be set to the same value for all devices on the network.	XX.X	19.2 (kb)		9.6/19.2
Parity	Used for error checking based on the number of bits in the transmitted data group.	E or n	E		E (Even) n (none)
Language	Work language for the screens	En or Fr	En		En (English) Fr (French)

For more information about installing and setting the BCM ULP communication module, consult the instruction sheet on the Schneider Electric website: [5100512864A](http://www.se.com/5100512864A)

MicroLogic A Trip Unit Setting Procedure

- Briefly press  to scroll through the possible settings for a given parameter.
 - Press and hold  to save the setting and go on to the next parameter.
 - After selecting the language, press and hold  to return to the **Metering** menu.
1. From the **Metering** menu, simultaneously press the two buttons to access the parameter settings for the communication option.

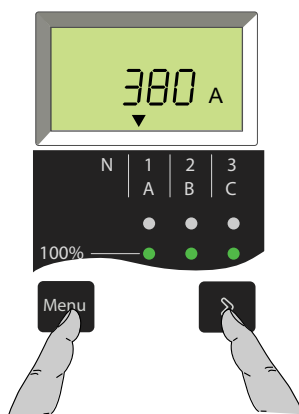

2. Select the desired Modbus address.

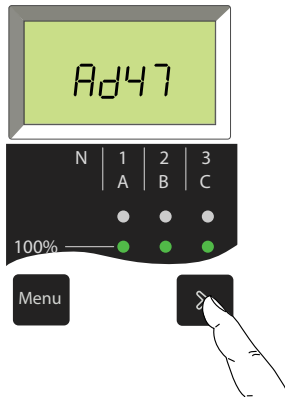

3. Press and hold to save the setting and go on to the next parameter.

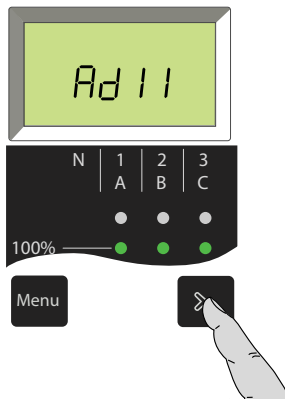

4. Select the desired baud rate.

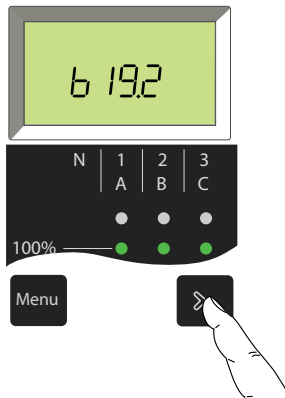

5. Press and hold to save the setting and go on to the next parameter.

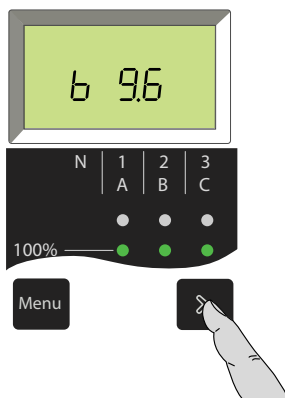

6. Select the desired parity setting.

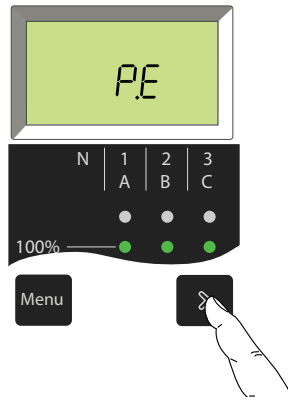

7. Press and hold to save the setting and go on to the next parameter.

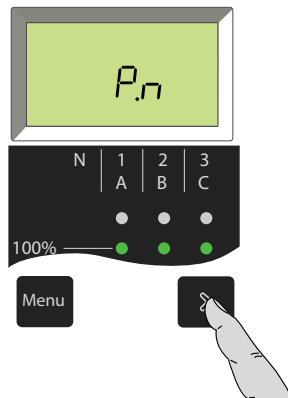

8. Select the desired language.

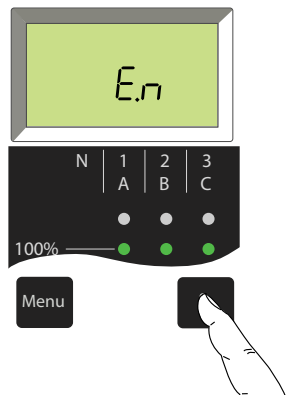

9. Press and hold to return to the **Metering** menu.

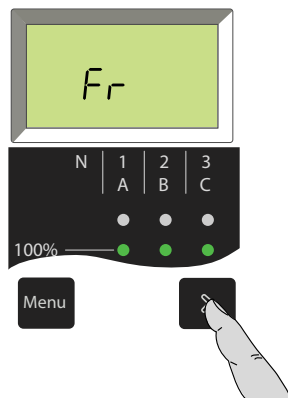

MicroLogic E Settings

Settings



MicroLogic E trip unit has two types of settings:

- Measurement settings
- Communication settings (optional)

The corresponding parameters (type of network, power sign, for example) have default values that can or must be changed according to the needs of the installation or users.

The following tables list these parameters and indicates their possible values. The parameters are displayed in the order indicated in the tables below.

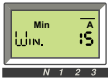
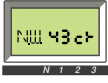

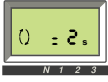

Measurement Settings

Parameter	Definition	Format (X = digit)	Default value (units)	Default screen	Possible values
Interval (window) for demand power calculation	Period of time over which the demand power is calculated.	XX	15 (minutes)		5 to 60 (in 1 minute steps)
Interval (window) for demand current calculation	Period of time over which the demand current is calculated.	XX	15 (minutes)		5 to 60 (in 1 minute steps)
Type of network (3-wire or 4-wire) and number of circuit breaker poles (CTs).	<ul style="list-style-type: none"> • Setting 43 = 4-wire (3ph +N) and 3-pole CB (3 CTs) • Setting 44 = 4-wire (3ph +N) and 4-pole CB (4 CTs) or 3-pole CB (3 CTs) + external CT • Setting 33 = 3-wire (3ph) and 3-pole CB (3 CTs) <p>NOTE: For 3-pole circuit breakers used on 3-wire systems (neutral not distributed), always set this value to 33 to avoid indications of a meaningless phase-to-neutral voltage.</p>	XX	43		43 44 33
Power sign	By default, the MicroLogic E trip unit considers power flowing into the circuit breaker via the top terminals to loads connected to the bottom terminals as positive (top fed).	+ or --	+		+ --
Quick View display duration	Duration of display of each screen in Quick View mode	X	2 (s)		1 to 9

Communication Settings

When the BCM ULP communication module is installed, the communication settings must be set.

The communication module should be set up only after installation. Modification of a setting on a system already in operation may lead to loss of communication.

Parameter	Definition	Format (X=digit)	Default value (units)	Default screen	Possible values
Modbus address	Modbus address of MicroLogic E on the Modbus network to which it is connected.	XX	47		1 to 47
Baud rate	Number of kbits/s (kbauds) exchanged on the Modbus network.	XX.X	19.2 (kb)		9.6/19.2
Parity	Used for error checking based on the number of bits in the transmitted data group.	E or n	E		E (Even) n (none)
Modbus connection	Type of Modbus connection: 4-wire (4) or 2-wire + ULP (ULP)	4 or ULP	4		4 ULP









For more information about installing and setting the BCM ULP communication module, consult the instruction sheet on the Schneider Electric website: 5100512864A

MicroLogic E Setting Procedure



The parameters are divided into two branches on the navigation tree:

- Measurement settings
- Communication settings

Follow this procedure to modify the settings. Examples for Modbus address and output settings are given after the procedure.



- To access the first screen of the communication settings branch, simultaneously press and hold (four seconds)  and  to access the first communication settings screen. The present value is displayed. A closed padlock icon indicates that the setting is locked.
- To unlock and access the setting to be changed, press  to open the padlock. The setting to be changed (or the first digit) will flash, indicating that it is ready to be modified.
- Press  to select the new setting. The possible settings are scrolled in a loop. Each press increments to the next setting or choices in the loop.
- Press  to confirm the new setting. It stops flashing and a closed padlock is displayed.
For a two-digit setting, this operation sets the first digit and the second digit flashes to indicate it is ready to be modified. Proceed as above to change it, that is, press  to modify the second digit then  to confirm it. The digit stops flashing, and a closed padlock is displayed. The new setting is locked.
- Press  to go to the screen for the next parameter in the communication settings branch.

To go to the next branch (measurement settings), press .

NOTE: Within a given branch, the various parameters are organized in a loop. You must scroll through all the parameters of the branch using  to return to the same parameter. To proceed to the next set-up branch (or exit the last branch), press .

Example: Setting the Modbus Address

The Modbus address is a two-digit number identifying the MicroLogic E trip unit in a Modbus network.

1. From the **Metering** menu, simultaneously press  and  for four seconds to access the Modbus address setting screen.

The existing address is displayed (default address 47 or XX). A closed padlock icon indicates that the value is locked.

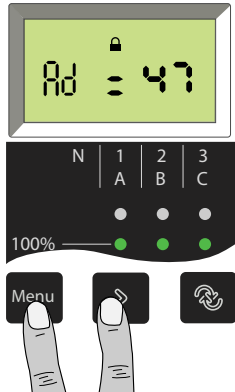

2. Unlock and access the first digit by pressing . It will flash, indicating it is ready to be modified.

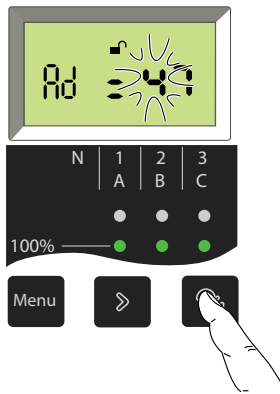

3. Modify the first digit by pressing  repeatedly until the new value for the first digit is displayed. You can scroll through all possible values in a loop.

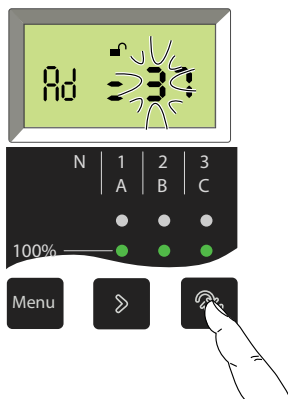

4. Confirm the first digit and access the second digit by pressing  to display the second digit. The first digit will stop flashing and the second digit will start flashing, indicating it is ready to be modified.

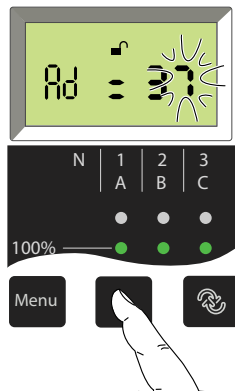

5. Modify the second digit by pressing  repeatedly until the new value for the second digit is displayed. You can scroll through all possible values in a loop, as for the first digit.

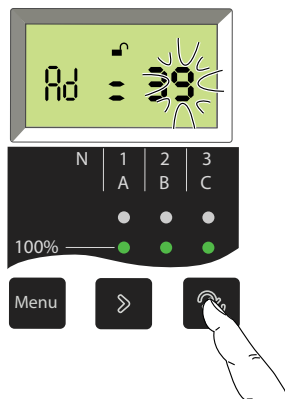

6. Confirm and lock the new setting by pressing  to confirm and lock the new setting. The second digit stops flashing and a closed padlock is displayed. The new setting is locked.

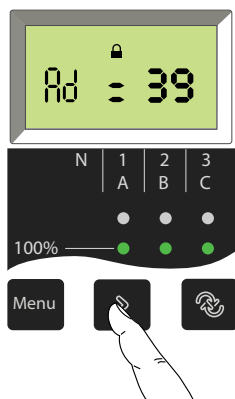

NOTE: The maximum address is 47. If you try to set a higher address, the MicroLogic trip unit will set the address to 47.

7. Display the next setting screen by pressing  again to go on to the next parameter.



Protection Settings for MicroLogic A/E Trip Unit

What's in This Part

Setting Procedure	49
Setting MicroLogic 2.0 A/E Trip Unit.....	50
Setting MicroLogic 5.0 A/E Trip Unit.....	51
Setting MicroLogic 6.0 A/E Trip Unit.....	52
Setting MicroLogic 7.0 A Trip Unit.....	54
Setting the Neutral Protection.....	56

Setting Procedure

1. Open the protective cover.

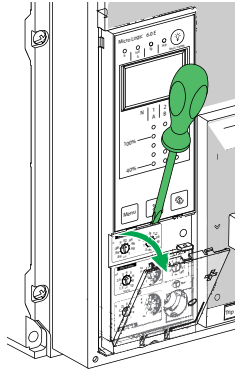

2. Make the necessary settings using the dials. The set value is automatically displayed on the screen in absolute value with the relevant units:
 - Current in amperes (A and kA).
 - Time delays in seconds.

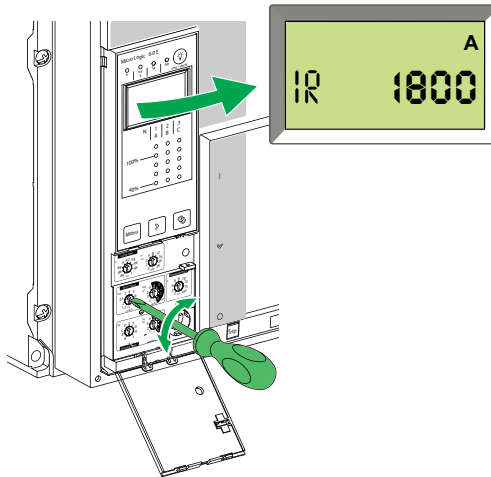

If no information is displayed, refer to [MicroLogic Display](#), page 85.

3. If no further action is taken, the display returns to the main menu for current measurements after a few seconds.
4. Close the protective cover and, if necessary, install a lead seal to protect the settings.

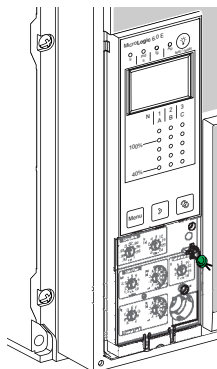

Setting MicroLogic 2.0 A/E Trip Unit

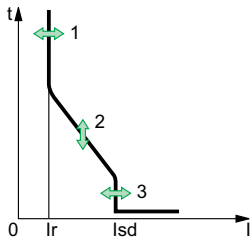

You can set the tripping curve of your MicroLogic 2.0 A/E trip unit to match the needs of your installation using the following parameters:

1. Current setting I_r (long time)
2. Time delay t_r (long time) for $6 \times I_r$
3. Pickup I_{sd} (instantaneous)

Set the Threshold Values

In this example, the rated current I_n of the circuit breaker is 2000 A.

$$I_r = 0.7 \times I_n = 1400 \text{ A}$$

$$I_{sd} = 3 \times I_r = 4200 \text{ A}$$

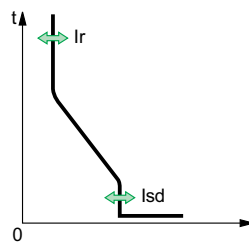
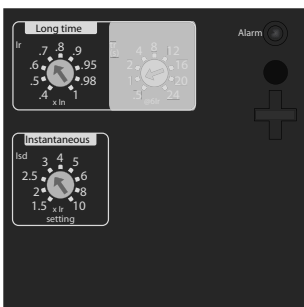

Set the Time Delay

In this example, time delay t_r of the circuit breaker is 1 second.

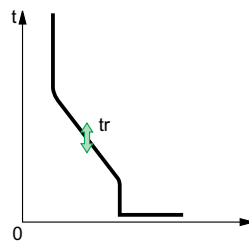
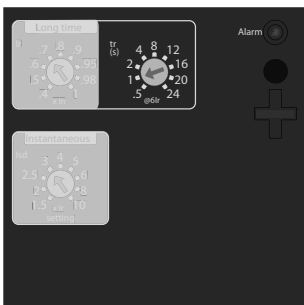

Setting MicroLogic 5.0 A/E Trip Unit

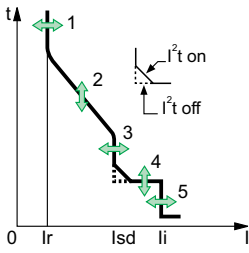

You can set the tripping curve of your MicroLogic 5.0 A/E trip unit to match the needs of your installation using the following parameters:

1. Current setting I_r (long time)
2. Time delay t_r (long time) for $6 \times I_r$
3. Pickup I_{sd} (short time)
4. Time delay t_{sd} (short time)
5. Pickup I_i (instantaneous)

Set the Threshold Values

In this example, the rated current I_n of the circuit breaker is 2000 A.

$I_r = 0.7 \times I_n = 1400 \text{ A}$

$I_{sd} = 2 \times I_r = 2800 \text{ A}$

$I_i = 3 \times I_n = 6000 \text{ A}$

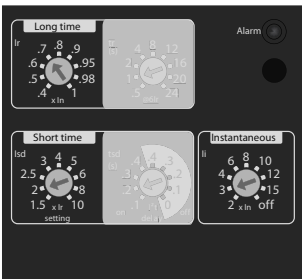

I²t ON curve

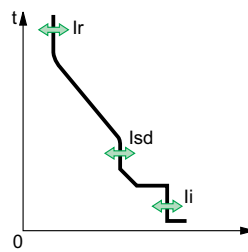

I²t OFF curve

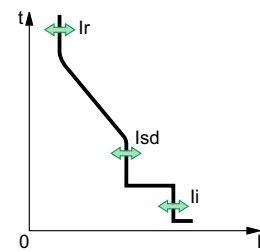

Set the Time Delays

In this example, time delay t_r of the circuit breaker is 1 second and time delay t_{sd} is 0.2 seconds.

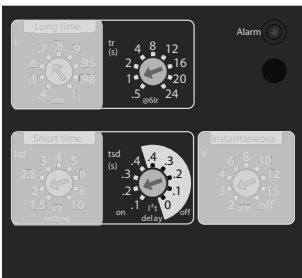

I²t ON curve

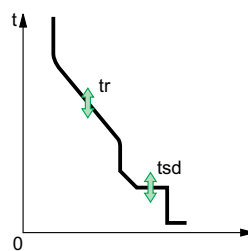

I²t OFF curve

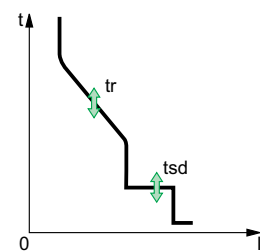

Setting MicroLogic 6.0 A/E Trip Unit

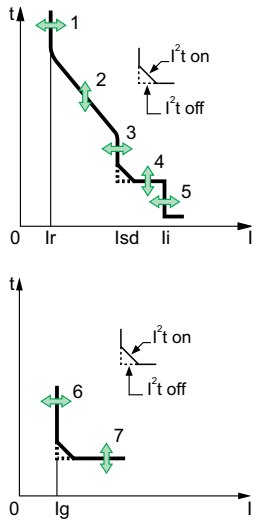

You can set the tripping curve of your MicroLogic 6.0 A/E trip unit to match the needs of your installation using the following parameters:

1. Current setting I_r (long time)
2. Time delay t_r (long time) for $6 \times I_r$
3. Pickup I_{sd} (short time)
4. Time delay t_{sd} (short time)
5. Pickup I_i (instantaneous)
6. Pickup I_g (ground fault)
7. Time delay t_g (ground fault)

Set the Threshold Values

In this example, the rated current I_n of the circuit breaker is 2000 A.

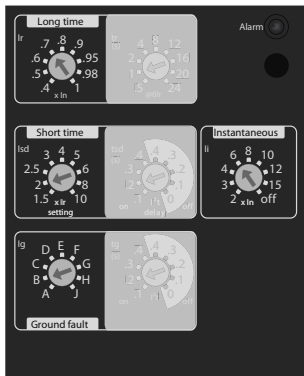

$I_r = 0.7 \times I_n = 1400 \text{ A}$
 $I_{sd} = 2 \times I_r = 2800 \text{ A}$
 $I_i = 3 \times I_n = 6000 \text{ A}$
 $I_g = 640 \text{ A}$

I²t ON curve

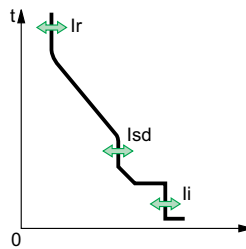

I²t OFF curve

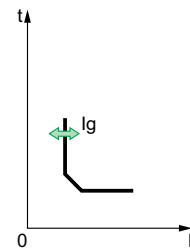
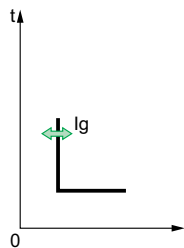
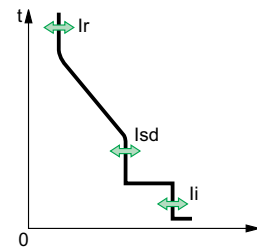

Set the Time Delays

In this example, time delay t_r of the circuit breaker is 1 second, time delay t_{sd} is 0.2 seconds, and time delay t_g is 0.2 seconds.

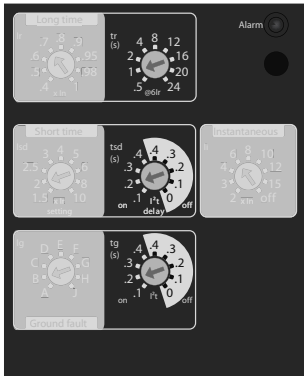

I²t ON curve

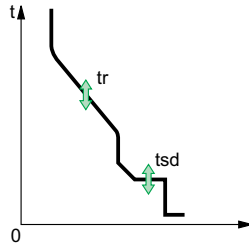

I²t OFF curve

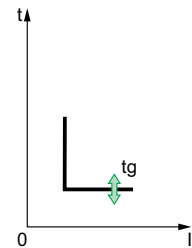
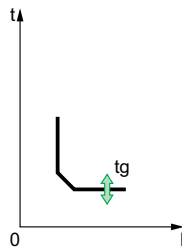
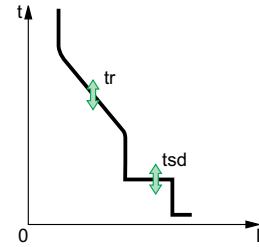

Setting MicroLogic 7.0 A Trip Unit

You can set the tripping curve of your MicroLogic 7.0 A trip unit to match the needs of your installation using the following parameters:

1. Current setting I_r (long time)
2. Time delay t_r (long time) for $6 \times I_r$
3. Pickup I_{sd} (Short time)
4. Time delay t_{sd} (short time)
5. Pickup I_i (instantaneous)
6. Pickup $I_{\Delta n}$ (earth leakage)
7. Time delay Δt (earth leakage)

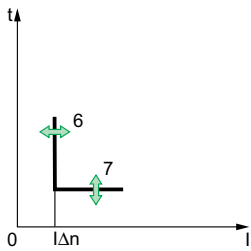
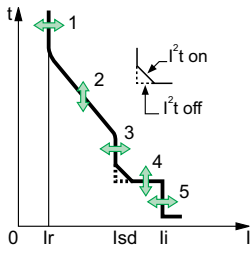

Set the Threshold Values

In this example, the rated current I_n of the circuit breaker is 2000 A.

$I_r = 0.7 \times I_n = 1400 \text{ A}$

$I_{sd} = 2 \times I_r = 2800 \text{ A}$

$I_i = 3 \times I_n = 6000 \text{ A}$

$I_{\Delta n} = 1 \text{ A}$

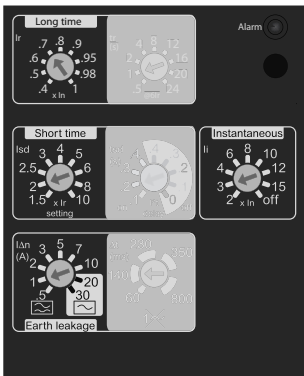

I²t ON curve

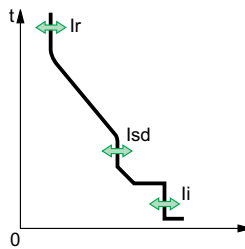

I²t OFF curve

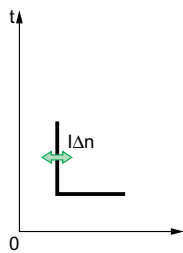
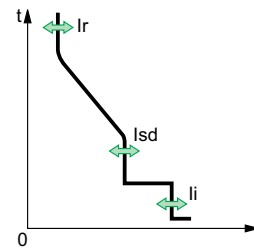

Set the Time Delays

In this example, time delay t_r of the circuit breaker is 1 second, time delay t_{sd} is 0.2 seconds and time delay $\Delta t = 140$ milliseconds

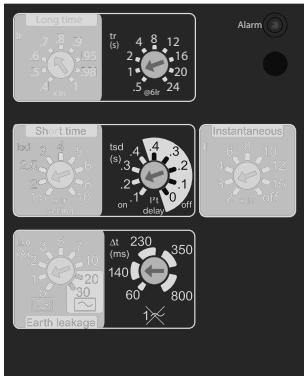

I²t ON curve

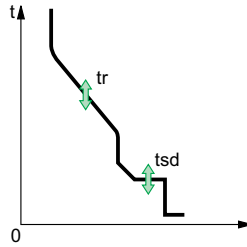

I²t OFF curve

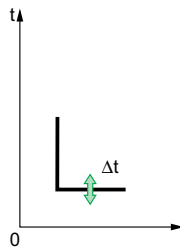
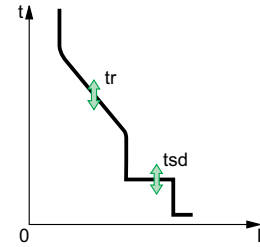

Setting the Neutral Protection

On four-pole circuit breakers, it is possible to select the type of neutral protection for the fourth pole using the three-position dial on the ComPacT NS circuit breaker:

- Neutral unprotected (4P 3D)

NOTE: With the 4P 3D setting, the current in the neutral must not exceed the rated current of the circuit breaker.

- Neutral protection at $0.5 I_n$ (3D + N/2, factory setting)
- Neutral protection at I_n (4P 4D)

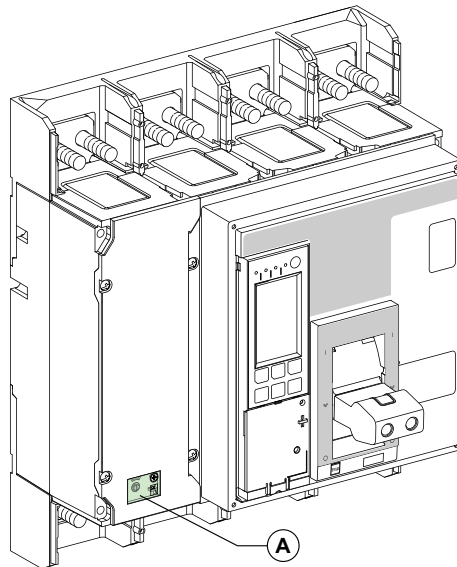

A. Cover for neutral protection three-position dial.

Follow these steps to set the type of neutral protection.

1. Remove the cover of the switch.

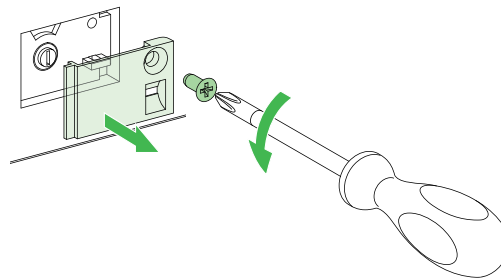

2. Select the protection type.

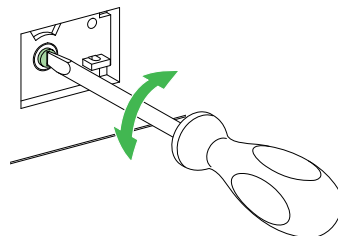

3. Put the cover back in place.

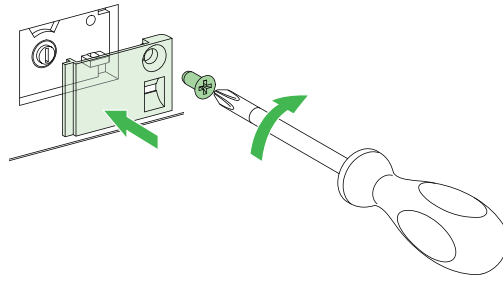

Protection Functions of MicroLogic A/E Trip Unit

What's in This Part

Long-Time Protection	59
Short-Time Protection	60
Instantaneous Protection	61
Ground-Fault Protection on MicroLogic 6.0 A/E Trip Unit	62
Earth-Leakage Protection on MicroLogic 7.0 A Trip Unit	63
Neutral Protection	64

Long-Time Protection

The long-time protection function protects cables (phases and neutral) against overloads. This function is based on true rms measurements.

Thermal Memory

The thermal memory, page 89 continuously accounts for the amount of heat in the cables, both before and after tripping, whatever the value of the current (presence of an overload or not). The thermal memory, page 89 optimizes the long-time protection function of the circuit breaker by taking into account the temperature rise in the cables. The thermal memory, page 89 assumes a cable cooling time of approximately 15 minutes.

Setting the I_r Pickup

The I_r pickup setting values depend on the long-time rating plug inserted in the MicroLogic A/E trip unit. For more information, refer to Long-Time Rating Plug, page 79.

$I_r \text{ pickup} = \text{setting value} \times I_n \text{ rated current.}$

As standard, trip units are equipped with the standard rating plug (0.4–1 x I_n).

Rating plug	Current setting								
Standard	0.4	0.5	0.6	0.7	0.8	0.9	0.95	0.98	1
Low-setting option	0.4	0.45	0.50	0.55	0.60	0.65	0.70	0.75	0.8
High-setting option	0.80	0.82	0.85	0.88	0.90	0.92	0.95	0.98	1
Off-plug	No long-time overcurrent protection (I _r = I _n for I _{sd} setting)								

NOTE: The long-time rating plug must always be removed, page 79 before carrying out insulation or dielectric withstand tests.

When the current is higher than I_{sd} or I_i, only short-time overcurrent protection and instantaneous protection are operational.

Setting the t_r Time Delay

The time delay settings indicated on the rating plugs correspond to the tripping times for an overload of 6 x I_r in cold-state conditions.

The table below gives tripping times according to t_r time delay.

Tripping time (s)	Accuracy	t _r time delay								
		0.5	1	2	4	8	12	16	20	24
at 1.5 x I _r	0 to -30%	12.5	25	50	100	200	300	400	500	600
at 6 x I _r	0 to -20%	0.5	1	2	4	8	12	16	20	24
at 7.2 x I _r	0 to -20%	0.34	0.69	1.38	2.7	5.5	8.3	11	13.8	16.6

Short-Time Protection

- The short-time protection function helps to protect the distribution system against impedant short-circuits.
- The short-time time delay can be used to help ensure selectivity with a downstream circuit breaker.
- This function carries out true rms measurements.
- The I²t ON and I²t OFF options enhance selectivity with downstream protection devices.
- Use of I²t curves with short-time protection:
 - I²t OFF selected: the protection function implements a constant time curve;
 - I²t ON selected: the protection function implements an I²t inverse-time curve up to 10 I_r. Above 10 I_r, the time curve is constant.
- Zone selective interlocking (ZSI).

The short-time and ground-fault protection functions enable time selectivity by delaying the upstream devices to provide the downstream devices the time required to clear the fault. Zone selective interlocking can be used to obtain total selectivity between circuit breakers using external wiring.

For the characteristics and external wiring of the zone selective interlocking function, refer to *Zone Selective Interlocking (ZSI)*, page 82.

Short-Time Pickup I_{sd}

Pickup (accuracy ± 10%)	I _{sd} = I _r x ...	1.5	2	2.5	3	4	5	6	8	10
-------------------------	--	-----	---	-----	---	---	---	---	---	----

Time Delay t_{sd}

t _{sd} time delay (s)	I ² t OFF	0	0.1	0.2	0.3	0.4
	I ² t ON	–	0.1	0.2	0.3	0.4
Tripping time at 10 x I _r (ms) with I ² t ON or I ² t OFF	Maximum resettable time	20	80	140	230	350
	Maximum break time	80	140	200	320	500

Instantaneous Protection

- The instantaneous-protection function helps to protect the distribution system against solid short-circuits. Contrary to the short-time protection function, the time delay for instantaneous protection is not adjustable.

The tripping order is sent to the circuit breaker as soon as current exceeds the set value, with a fixed time delay of 20 milliseconds.

- This function carries out true rms measurements.

Instantaneous Pickup

MicroLogic 2.0 A/E	Pickup (accuracy $\pm 10\%$)	$I_{sd} = I_r \times \dots$	1.5	2	2.5	3	4	5	6	8	10
MicroLogic 5.0 A/E, 6.0 A/E, 7.0 A	Pickup (accuracy $\pm 10\%$)	$I_i = I_n \times \dots$	2	3	4	6	8	10	12	15	OFF

Ground-Fault Protection on MicroLogic 6.0 A/E Trip Unit

- A ground fault in the protection conductors can provoke local temperature rise at the site of the fault or in the conductors.

The purpose of the ground-fault protection function is to eliminate this type of fault.

- There are two types of ground-fault protection, depending on the type of installation.

Type	Description
Residual	<ul style="list-style-type: none"> ◦ The function determines the zero-phase sequence current, i.e. the vector sum of the phase and neutral currents. ◦ It detects ground faults downstream of the circuit breaker.
Source Ground Return	<ul style="list-style-type: none"> ◦ Using a special external sensor, this function directly measures the fault current returning to the transformer via the grounding cable. ◦ It detects ground faults both upstream and downstream of the circuit breaker ◦ The maximum distance between the sensor and the circuit breaker is 10 m (33 ft).

- Ground-fault and neutral protection are independent and can therefore be combined.
- Zone selective interlocking (ZSI).

The short-time and ground-fault protection functions enable time selectivity by delaying the upstream devices to provide the downstream devices the time required to clear the fault. Zone selective interlocking can be used to obtain total selectivity between circuit breakers using external wiring.

For the characteristics and external wiring of the zone selective interlocking function, refer to *Zone Selective Interlocking (ZSI)*, page 82.



Ground-Fault Pickup I_g

I _g Pickup (accuracy ± 10%)	I _n ≤ 400 A	I _g = I _n x...	A	B	C	D	E	F	G	H	I
			0.3	0.3	0.4	0.5	0.6	0.7	0.8	0.9	1
	400 A < I _n ≤ 1200 A	I _g = I _n x...	0.2	0.3	0.4	0.5	0.6	0.7	0.8	0.9	1
	I _n > 1200 A	I _g = ...	500 A	640 A	720 A	800 A	880 A	960 A	1040 A	1120 A	1200 A

Time Delay t_g

t _g Time delay (s)	I _g OFF	0	0.1	0.2	0.3	0.4
	I _g ON	—	0.1	0.2	0.3	0.4
Tripping time (ms) at I _n or at 1200 A with I _g ON or I _g OFF	Maximum resettable time	20	80	140	230	350
	Maximum break time	80	140	200	320	500

Earth-Leakage Protection on MicroLogic 7.0 A Trip Unit

- The earth-leakage protection function primarily protects people against indirect contact because an earth-leakage current can provoke an increase in the potential of the exposed conductive parts.
- The earth-leakage pickup value $I\Delta n$ is displayed directly in amperes and the time delay follows a constant-time curve.
- An external rectangular sensor is required for this function.
- This function is inoperative if the long-time rating plug is not installed.
-  As a type-AC, the circuit breaker is protected against nuisance tripping.
-  As a type-A, the circuit breaker provides DC-component withstand up to 10 A.

Earth-Leakage Pickup Value $I\Delta n$

$I\Delta n$ pickup (A) (accuracy 0 to -20 %)	0.5	1	2	3	5	7	10	20	30
--	-----	---	---	---	---	---	----	----	----

Time Delay Δt

Δt time delay settings (ms) (Maximum resettable time)	60	140	230	350	800
Δt maximum break time (ms)	140	200	320	500	1000

Neutral Protection

Protection of the Neutral Conductor on Four-Pole Circuit Breakers

Protection of the neutral conductor depends on the distribution system. There are three possibilities.

Type of neutral	Description
Neutral unprotected	The distribution system does not require protection of the neutral conductor.
Half neutral protection (at $0.5 I_n$)	<p>The cross-sectional area of the neutral conductor is half that of the phase conductors.</p> <ul style="list-style-type: none"> The long-time current setting I_r for the neutral is equal to half the setting value. The short-time pickup I_{sd} for the neutral is equal to half the setting value. The instantaneous pickup I_{sd} (MicroLogic 2.0 A/E) for the neutral is equal to half the setting value. The instantaneous pickup I_i (MicroLogic 5.0 A/E / 6.0 A/E / 7.0 A) for the neutral is equal to the setting value.
Full neutral protection (at I_n)	<p>The cross-sectional area of the neutral conductor is half that of the phase conductors.</p> <ul style="list-style-type: none"> The long-time current setting I_r for the neutral is equal to the setting value. The short-time pickup I_{sd} for the neutral is equal to the setting value. The instantaneous pickup I_{sd} and I_i for the neutral are equal to the setting value.

Neutral Protection for Three-Pole Devices

Neutral protection is not available on three-pole devices.

Other Functions of MicroLogic A/E Trip Unit

What's in This Part

Measurements	66
Trip History for MicroLogic E Trip Unit	69
Communication Function	70

Measurements

Measurement and Display Possibilities

MicroLogic A trip unit measures instantaneous currents and stores the maximum values in maximeters.

MicroLogic E trip unit measures the same values as the MicroLogic A trip unit, plus voltage, power and energy values.

MicroLogic A/E trip unit measurements can be displayed on:

- The screen of the trip unit (refer to the detailed topic, page 31 for MicroLogic A trip unit, refer to the detailed topic, page 32 for MicroLogic E trip unit)
- An optional FDM121 front display module
- A PC via the Modbus communication (COM) option (refer to the detailed topic, page 70).

The following table indicates MicroLogic A/E trip unit measurement and display possibilities.

Measurements	Micro-Logic A	Micro-Logic E	Displayed on:		
			MicroLogic	FDM121	COM
Instantaneous currents I1, I2, I3, IN, Ig, IΔn	✓	✓	✓	✓	✓
Current maximeters I1max, I2max, I3max, INmax, Igmax, IΔnmax	✓	✓	✓	✓	✓
Demand current $\bar{I}_1, \bar{I}_2, \bar{I}_3, \bar{I}_N$	–	✓	✓	✓	✓
Demand current maximeters (peak demand) I1 max, I2 max, I3 max, IN max	–	✓	–	✓	✓
Phase-to-phase voltages V12, V23, V31 (3-wire and 4-wire systems)	–	✓	✓	✓	✓
Phase-to-neutral voltages V1N, V2N, V3N (4-wire systems)	–	✓	✓	✓	✓
Average voltage Vavg	–	✓	–	✓	✓
Voltage unbalance Vunbal	–	✓	–	✓	✓
Instantaneous powers P, Q, S	–	✓	✓	✓	✓
Power maximeters Pmax, Qmax, Smax	–	✓	–	✓	✓
Demand active power \bar{P}	–	✓	✓	✓	✓
Demand apparent power \bar{S}	–	✓	–	✓	✓
Demand power maximeter (peak demand) \bar{P}_{max}	–	✓	–	✓	✓
Instantaneous power factor PF	–	✓	✓	✓	✓
Active energy Ep	–	✓	✓	✓	✓
Reactive and apparent energy Eq, Es	–	✓	–	✓	✓

If no information is displayed on the screen, refer to MicroLogic Display, page 85.

NOTE:

- The instantaneous currents I1, I2, I3 are also displayed by LEDs on the MicroLogic front face, page 17.
- The display of the neutral current (IN) is available with MicroLogic E trip unit when the parameter **Type of network** has been set to **4-wire 4ct (44)**, page 43.
- For 3-pole circuit breakers used on 4-wire systems (3 phases + neutral), terminal VN on the MicroLogic trip unit must always be connected to the neutral. If this is not done, the phase-to-neutral voltage measurements can be erroneous.

Measurement Definitions

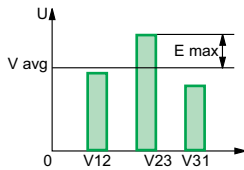
Measurement	Definition
Instantaneous current	The rms value of the instantaneous time current.
Neutral current	Available with a four-pole circuit breaker or three-pole circuit breaker with external neutral sensor.
Current maximeter	Maximum value of the instantaneous time current (refreshed every 500 ms) since MicroLogic installation or last reset.
Demand current	Mean of all instantaneous time current values over a given user-adjustable time interval (for example, 10 minutes). For more information, refer to <i>Calculating Demand Values</i> , page 90.
Voltage	The rms value of the voltage.
Average voltage	Average of the 3 phase-to-phase voltages V12, V23 and V31: $V_{avg} = \frac{V_{12} + V_{23} + V_{31}}{3}$
Voltage unbalance	Voltage unbalance on the most unbalanced phase, displayed as a percentage of Vavg.  <p>MicroLogic Etrip unit measures the maximum difference between the instantaneous time voltage of each phase and Vavg, and calculates the voltage unbalance:</p> $V_{unbal} = \frac{ E_{max} }{3}$
Instantaneous power	P: total active power Q: total reactive power S: total apparent power P, Q and S are rms instantaneous values.
Power maximeter	Maximum value of the instantaneous time power (refreshed every 1 s) since MicroLogic installation or last reset.
Demand power	Mean of all instantaneous time power values over a given user-adjustable time interval (for example, 10 min). For more information, refer to <i>Calculating Demand Values</i> , page 90.

Measurement	Definition
Instantaneous power factor PF	$PF = P / S$
Total energy	Ep: total active energy Eq: total reactive energy Es: total apparent energy

Trip History for MicroLogic E Trip Unit

The trip history of MicroLogic E trip units can be used to analyze circuit breaker tripping, thereby increasing the overall availability of your installation.

The trip history displays the list of the last 10 trips.

For each trip, the following indications are recorded and displayed:

- The tripping cause: Ir, Isd, li, Ig or Auto-protection (Ap) trips
- The date and time of the trip (requires communication option) in order to set Date and Time

List of trip causes:

- Overloads (Ir)
- Short-circuits (Isd or li)
- Ground faults (Ig)
- Auto-protection (Ap)

For more information, refer to [Displaying Trip History](#), page 38.

Communication Function

Modbus Communication Option

The Modbus communication option enables a ComPacT NS circuit breaker to be connected to a supervisor or to any other device with a master Modbus communication channel.

The Modbus communication option consists of the BCM ULP circuit breaker communication module, installed behind the MicroLogic trip unit.

With the communication option, the ComPacT NS circuit breaker can be connected to the following networks:

- An RS-485 serial line network with Modbus protocol via an IFM Modbus-SL interface for one circuit breaker
- An Ethernet network with Modbus TCP/IP protocol via an IFE Ethernet interface for one circuit breaker or an IFE Ethernet switchboard server

For more information, refer to DOCA0220EN *ComPacT NS - Modbus Communication Guide*.

Communication Architecture

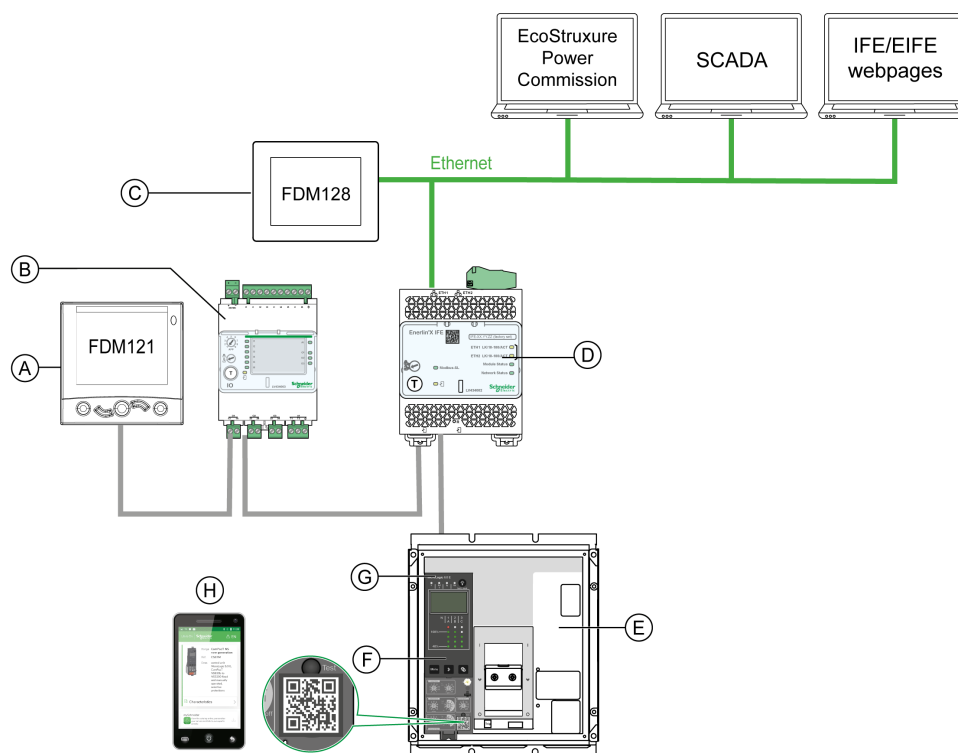

- FDM121 front display module for one circuit breaker
- IO input/output application
- FDM128 Ethernet display for eight devices
- IFE interface
- ComPacT NS circuit breaker
- MicroLogic trip unit
- BCM ULP circuit breaker communication module (installed in ComPacT NS circuit breaker)
- Go2SE landing page

Maintenance of the MicroLogic A/E Trip Unit

What's in This Part

Checking and Replacing the Internal Battery	72
Testing the Ground-Fault and Earth-Leakage Protection Functions	74
Testing the MicroLogic Trip Unit	75

The MicroLogic A/E trip unit can be changed on site. For more information, contact your field service representative.

Checking and Replacing the Internal Battery

Checking the MicroLogic A Internal Battery

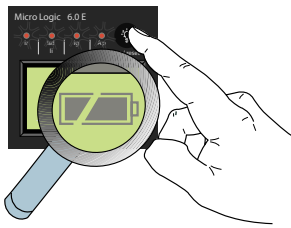

Press and hold  on the trip unit to check the trip cause indication LEDs and the battery. The battery information is displayed if the trip unit is equipped with an external power supply or if the circuit breaker is ON.



Battery charged



Battery half charged



Change battery

NOTE: If no information appears on the screen, check that a battery is installed in the trip unit or connect an auxiliary power supply. For more information about power supplies, refer to *MicroLogic Display*, page 85.

Checking the MicroLogic E Internal Battery

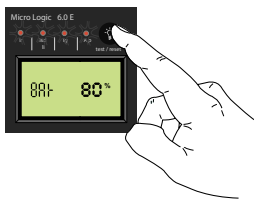

Press and hold down  on the trip unit to check the trip cause indication LEDs and the battery. The battery information is displayed if the trip unit is equipped with an external power supply or if the circuit breaker is ON.

The battery charge level is displayed as a percentage (100 %, 80 %, 60 %, 40 %, 20 % or 0 %).

NOTE: If no information appears on the screen, check that a battery is installed in the trip unit or connect an auxiliary power supply. For more information about power supplies, refer to *MicroLogic Display*, page 85.

Internal Battery

If the MicroLogic A/E battery needs to be changed, order a new battery in its housing cover with the Schneider Electric catalogue number **33593**.

- Lithium battery
- 1/2 AA, 3.6 V, 900 mA/h
- Ambient temperature: -55 °C to 130 °C (-67 °F to 266 °F)

Replacing the Internal Battery

⚡⚠ DANGER

HAZARD OF ELECTRIC SHOCK, EXPLOSION, OR ARC FLASH

- Apply appropriate personal protective equipment (PPE) and follow safe electrical work practices. See NFPA 70E, CSA Z462, NOM 029-STPS or local equivalent.
- This equipment must only be installed and serviced by qualified electrical personnel.
- Turn off all power supplying this equipment before working on or inside this equipment.
- Always use a properly rated voltage sensing device to confirm power is off.
- Put back all devices, doors, and covers before turning on power to this equipment.
- Beware of potential hazards, and carefully inspect the work area for tools and objects that may have been left inside the equipment.

Failure to follow these instructions will result in death or serious injury.

Follow this procedure to replace the internal battery:

1. Remove the circuit breaker front cover as directed in the circuit breaker instruction sheet.
2. Remove the battery and its housing cover: insert a small screwdriver blade into battery housing cover notch and rotate to slide battery housing cover out of trip unit.

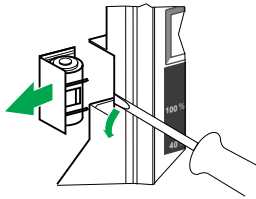

3. Put the new battery and its housing cover back in place.

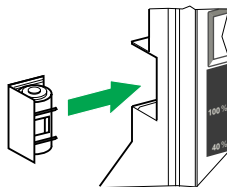

4. Press  to check the new battery.
5. Reinstall the circuit breaker front cover as directed in the circuit breaker instruction sheet.

⚡⚠ DANGER

HAZARD OF ELECTRIC SHOCK, EXPLOSION, OR ARC FLASH

- Put back circuit breaker front cover before energizing circuit breaker to help prevent access to live terminals.
- Do not pinch the wires when reinstalling the front cover.

Failure to follow these instructions will result in death or serious injury.

Testing the Ground-Fault and Earth-Leakage Protection Functions

Proceed as follows to test:

- Ground-fault protection on MicroLogic 6.0 A/E trip units.
 - Earth-leakage protection on MicroLogic 7.0 A trip units.
1. Check that the circuit breaker is closed.
 2. Use a thin screwdriver to briefly push in (< 1 s) the **TEST** button on the front face of the MicroLogic trip unit.

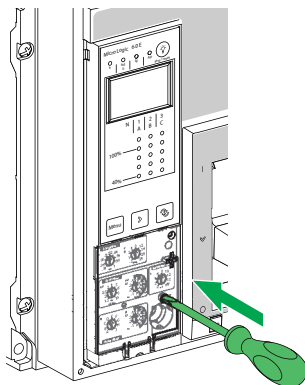

3. The circuit breaker trips.
4. If the circuit breaker does not trip, contact your field service representative.

Testing the MicroLogic Trip Unit

Test the trip unit using EcoStruxure Power Commission software installed on a PC and connected to the MicroLogic trip unit through the Service Interface.

Testing Architecture

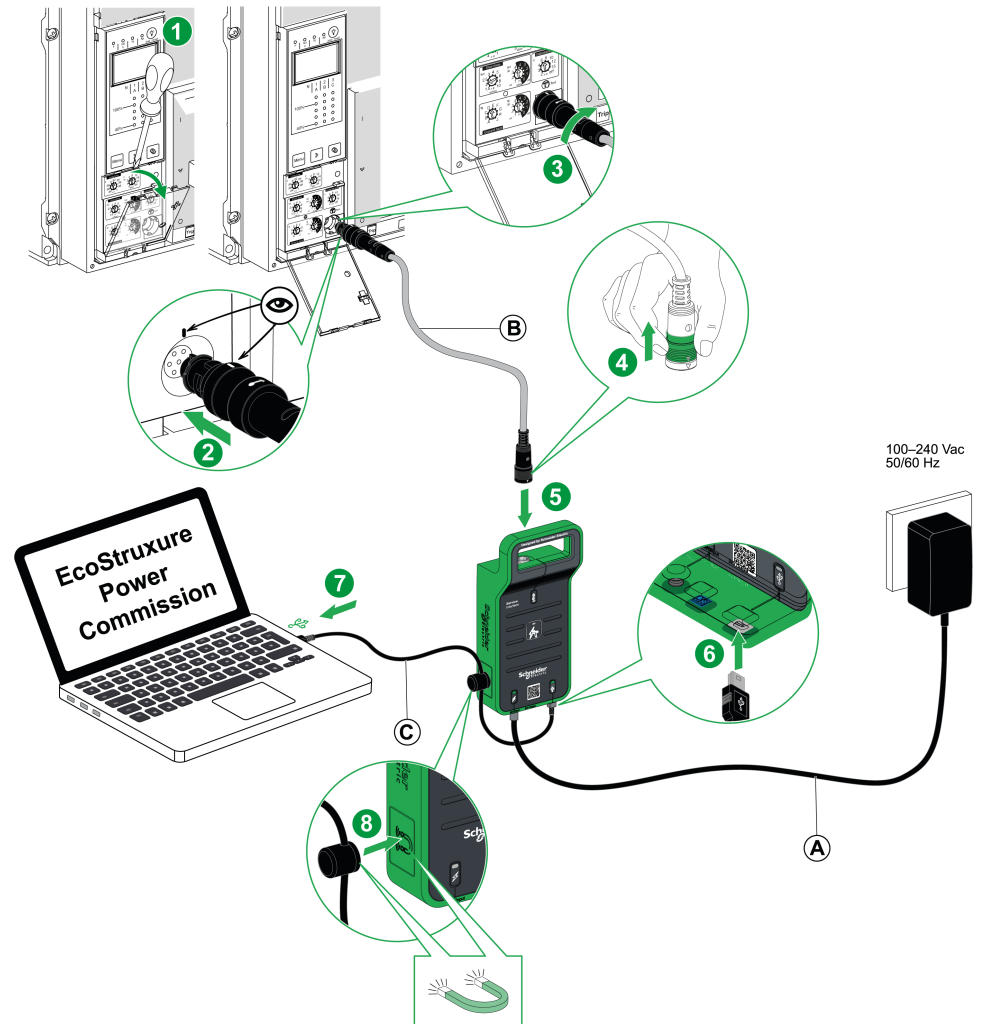

- A. AC/DC power supply
- B. 7-pin cable for ComPacT NS trip units
- C. USB cable with magnet

For more information, refer to *GDE78167 Service Interface - Instruction Sheet*.

Test Functions with EcoStruxure Power Commission Software

EcoStruxure Power Commission software allows you to perform the following actions on a communicating MicroLogic trip unit through the Service Interface:

- Automatic trip curve tests
- Device check up (Force trip test)
- Zone-selective interlocking (ZSI) test
- Preparation for primary injection tests

For more information, refer to *DOCA0170EN Service Interface - User Guide*.

Technical Appendix

What's in This Part

Tripping Curves.....	77
Long-Time Rating Plug	79
Zone Selective Interlocking (ZSI).....	82
MicroLogic Display	85
Power Supply	86
Thermal Memory	89
Calculating Demand Values (MicroLogic E).....	90
Measurement Ranges and Accuracy	92

Tripping Curves

Long-Time and Instantaneous Protection (MicroLogic 2.0 A/E)

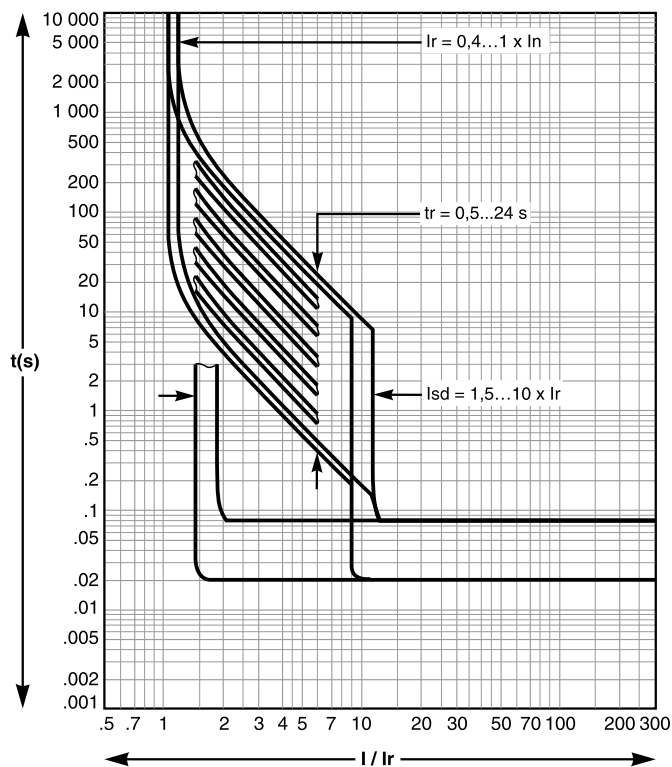

Long-Time, Short-Time and Instantaneous Protection (MicroLogic 5.0 A/E, 6.0 A/E and 7.0 A)

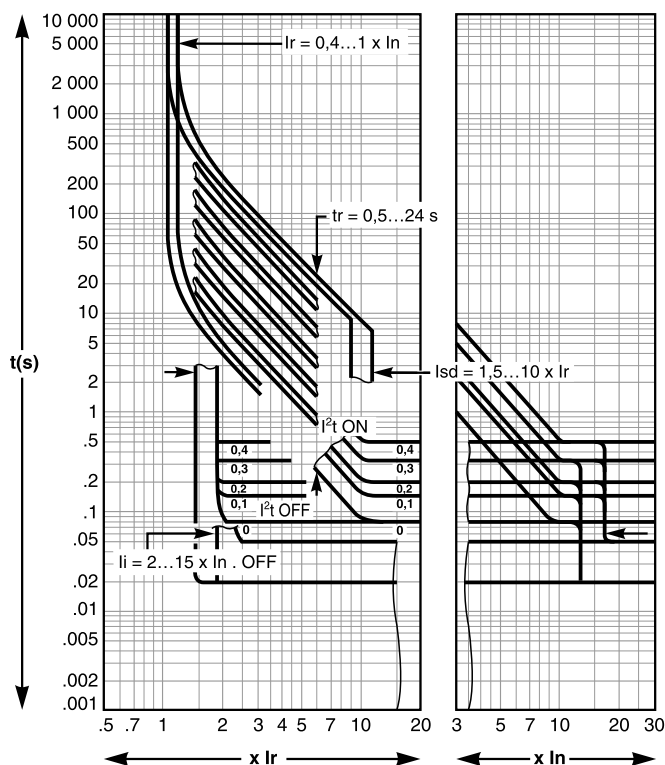

Ground-Fault Protection (MicroLogic 6.0 A/E)

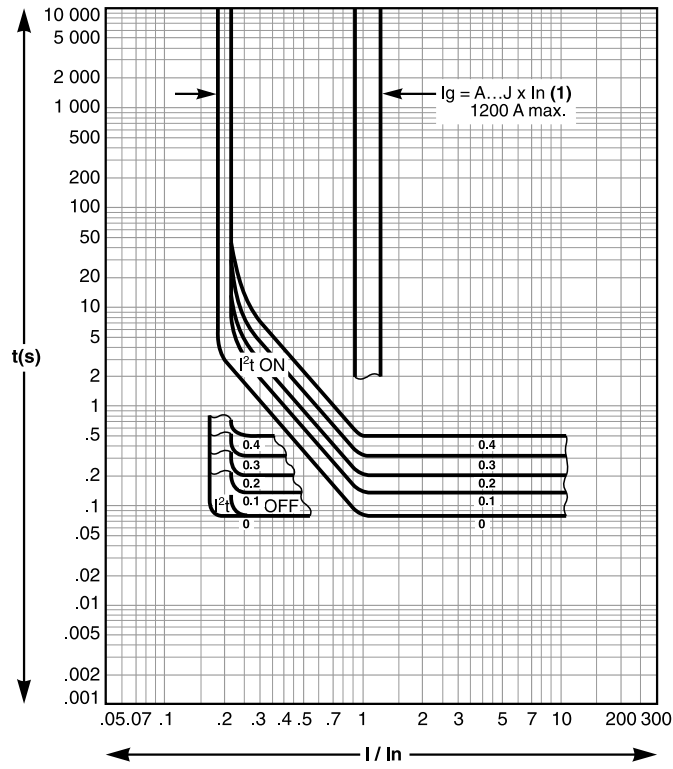

Long-Time Rating Plug

One of four interchangeable long-time rating plugs can be used to limit the long-time pickup setting range for higher accuracy of the long-time protection, page 59.

Selecting the Long-Time Rating Plug

The available rating plugs are listed in the following table:

Part number	Setting range for the I _r value	
C33542	Standard	0.4–1 x I _r
C33543	Low setting	0.4–0.8 x I _r
C33544	High setting	0.8–1 x I _r
C33545	Without long-time protection I _r = I _n for short-time protection setting	

NOTE: If no long-time rating plug is installed, the trip unit continues to operate under the following downgraded conditions:

- The long-time current setting I_r is 0.4.
- The long-time time delay t_r corresponds to the value indicated by the adjustment dial.
- The earth-leakage protection function is disabled.

Replacement Procedure

 **DANGER**

HAZARD OF ELECTRIC SHOCK, EXPLOSION, OR ARC FLASH

- Apply appropriate personal protective equipment (PPE) and follow safe electrical work practices. See NFPA 70E, CSA Z462, NOM 029-STPS or local equivalent.
- This equipment must only be installed and serviced by qualified electrical personnel.
- Turn off all power supplying this equipment before working on or inside this equipment.
- Always use a properly rated voltage sensing device to confirm power is off.
- Put back all devices, doors, and covers before turning on power to this equipment.
- Beware of potential hazards, and carefully inspect the work area for tools and objects that may have been left inside the equipment.

Failure to follow these instructions will result in death or serious injury.

NOTICE

HAZARD OF TRIP UNIT DETERIORATION

Prior to running dielectric strength tests, it is mandatory to:

- Remove the long-time rating plug on MicroLogic E trip unit.
- Disconnect all electrical auxiliaries (for example, MX or MN voltage releases) connected to the device.

Failure to follow these instructions can result in equipment damage.

Follow this procedure to change or remove the rating plug:

1. Open the circuit breaker.
2. Open the protective cover of the trip unit.

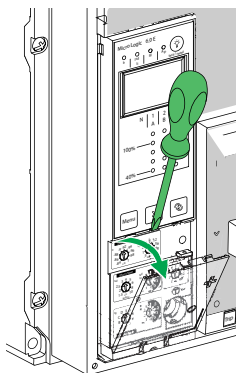

3. Record switch settings.
4. Unscrew the long-time rating plug mounting screw.

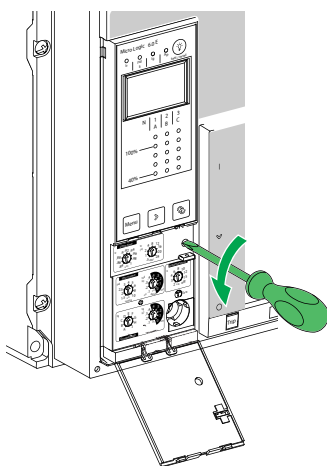

5. Remove the adjustable rating plug.

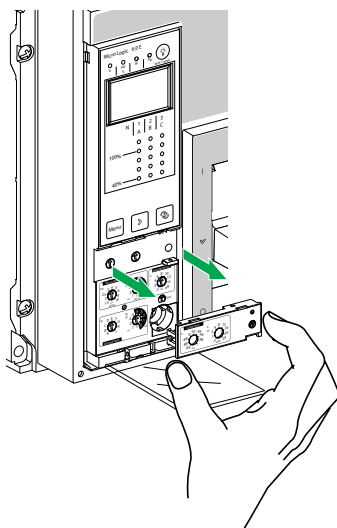

6. Inspect mounting area for debris and contamination.
7. Take out the replacement rating plug.

8. Gently push in the replacement rating plug.

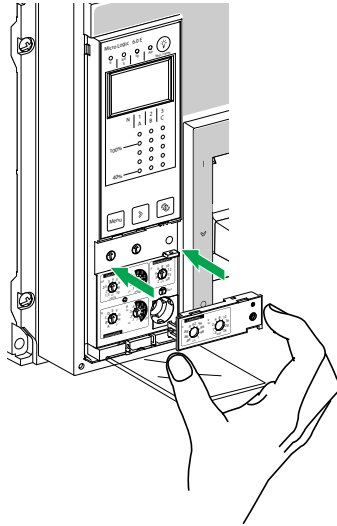

9. Tighten the long-time rating plug mounting screw.
10. Set trip unit settings to values recorded previously or modify settings.

Zone Selective Interlocking (ZSI)

Presentation

Zone-selective interlocking (ZSI), also called zone restraint, is a system designed to reduce the stress on electrical distribution equipment during short-circuit or ground-fault conditions.

ZSI works with a previously coordinated distribution system to limit stress on the system by reducing the time it takes to clear the electrical fault while maintaining system coordination between overcurrent and ground-fault protective devices.

ZSI allows MicroLogic trip units to communicate with each other so that a short-circuit or ground-fault can be isolated and cleared by the nearest upstream circuit breaker with no intentional time delay. Devices in all other areas of the system (including upstream) remain closed to maintain service to unaffected loads.

Without ZSI, a coordinated system results in the circuit breaker closest to the electrical fault clearing it, usually with an intentional delay. With ZSI, the device closest to the electrical fault ignores its preset short-time and ground-fault delays and clears the electrical fault with no intentional delay.

Zone-selective interlocking eliminates intentional delay without sacrificing coordination and it results in faster tripping times. This limits stress on the system by reducing the amount of let-through energy the system is subjected to during an overcurrent.

The coordination of the system must be correctly set up for zone-selective interlocking to work.

Operating Principle

A pilot wire interconnects a number of circuit breakers equipped with MicroLogic trip units, as illustrated in the following diagram.

The trip unit detecting an electrical fault sends a signal upstream and checks for a signal arriving from downstream. If there is a signal from downstream, the circuit breaker remains closed for the full duration of its time delay. If there is no signal from downstream, the circuit breaker opens immediately, regardless of the time delay setting.

- An electrical fault occurs at point A.

Downstream device (2) clears the electrical fault and sends a signal to upstream device (1), which maintains the short-time time delay t_{sd} or the ground-fault time delay t_g to which it is set.

- An electrical fault occurs at point B.

Upstream device (1) detects the electrical fault. In the absence of a signal from a downstream device, the set time delay is not taken into account and the device trips according to the zero setting. If it is connected to a device further upstream, it sends a signal to that device, which delays tripping according to its t_{sd} or t_g setting.

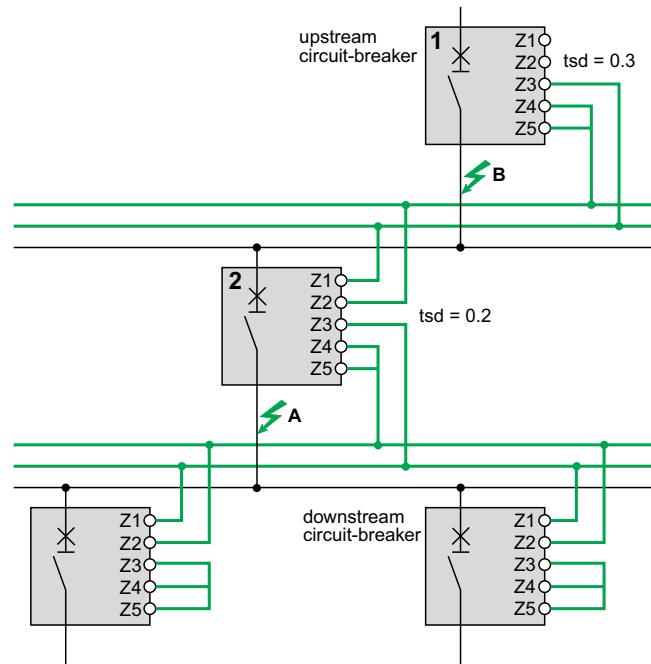

NOTE: On device (1), the tsd and tg time delays must not be set to zero because this would make selectivity impossible.

Connections Between Trip Units

A logic signal (0 or 5 V) can be used for zone selective interlocking between the upstream and downstream circuit breakers equipped with:

- MicroLogic 5.0 A, 6.0 A, 7.0 A.
- MicroLogic 5.0 E, 6.0 E.
- MicroLogic 5.0 P, 6.0 P, 7.0 P.
- MicroLogic 5.0 H, 6.0 H, 7.0 H.

An interface is available for connection to previous generations of trip units.

Wiring

Technical characteristics of wires:

- Maximum impedance: 2.7 Ω / 300 m (1 000 ft)
- Capacity of connectors: 0.4 to 2.5 mm² (AWG 22 to 14)
- Wires: single or multicore
- Maximum length: 3000 m (10 000 ft)
- Limits to device interconnection:
 - The common ZSI - OUT (Z1) and the output ZSI - OUT (Z2) can be connected to a maximum of 10 upstream devices.
 - Maximum of 100 downstream devices may be connected to the common ZSI - IN (Z3) and to an input ZSI - IN CR (Z4) or GF (Z5).

NOTE: Terminals Z1 to Z5 correspond to the identical indications on the circuit-breaker terminal blocks.

NOTE: If the protection function is not used on circuit breakers equipped for ZSI protection, a jumper must be installed to short terminals Z3, Z4 and Z5. If the jumper is not installed, the short-time and ground-fault time delays are set to zero, whatever the position of the adjustment dial.

Test

Check the wiring and operation of zone selective interlocking between a number of circuit breakers by using EcoStruxure Power Commission software installed on a PC and connected to the MicroLogic trip unit through the Service Interface.

For more information, refer to [Testing the MicroLogic A/E Trip Unit](#), page 75.

MicroLogic Display

Presentation

The MicroLogic display operates without an external power supply.

The display goes off if the current drops below $0.2 \times I_n$ (I_n = rated current).

An optional 24 Vdc external power supply may be used to maintain the display of currents even when the current drops below $0.2 \times I_n$.

For more information on connecting an external power supply, refer to the electrical diagrams in [DOCA0221EN ComPacT NS - Circuit Breakers and Switch-Disconnectors - User Guide](#).

Back-Lighting and Maximeter

Display back-lighting is disabled in the following situations:

- Current less than $1 \times I_n$ on one phase
- Current less than $0.4 \times I_n$ on two phases
- Current less than $0.2 \times I_n$ on three phases

The maximeter does not operate for currents under $0.2 \times I_n$.

NOTE: The display back-lighting and the maximeter may be maintained, whatever the current, by adding a 24 Vdc external power supply.

Power Supply

Internal and External Power Supplies

The MicroLogic trip unit is powered by the current through the internal current transformers (CT).

- The standard protection functions of MicroLogic trip units operate with the internal current supply.
- If the load current is higher than 20% of the rated current I_n , the internal current supply provides the power supply for the full functioning of the MicroLogic trip unit. This includes:
 - The MicroLogic HMI, display screen and LEDs
 - The metering functions

To provide a power supply to the MicroLogic trip unit when the load is below 20% of the rated current I_n , and maintain the full functioning of the MicroLogic trip unit, a permanent external 24 Vdc power supply can be used.

External 24 Vdc Power Supply

The 24 Vdc power supply maintains the operation of all functions of the MicroLogic trip unit in all circumstances, even when the circuit breaker is open and not energized.

The 24 Vdc power supply maintains the functions of the MicroLogic trip unit in low load conditions (load below 20%).

NOTICE

LOSS OF DOUBLE INSULATION

- Supply the MicroLogic trip unit with a 24 Vdc SELV (Safety Extra Low Voltage) power supply only, connected to the F1-/F2- terminals. Pay attention to the polarity.
- Do not connect devices which have double insulation to the 24 Vdc SELV power supply which is being used to supply the MicroLogic trip unit. For example, do not use the same 24 Vdc SELV power supply to supply a MicroLogic trip unit for ComPacT NS circuit breakers and a MicroLogic X control unit for MasterPact MTZ circuit breakers.

Failure to follow these instructions will result in a basic/single insulated system.

NOTICE

HAZARD OF EQUIPMENT DAMAGE

- Do not use the same 24 Vdc SELV power supply to supply the MicroLogic trip unit and the other ULP modules connected to the BCM ULP module.
- Do not use the same 24 Vdc SELV power supply to supply more than one MicroLogic trip unit.

Failure to follow these instructions can result in equipment damage.

Recommendations for use of external 24 Vdc SELV power supplies:

- Use separate 24 Vdc power supplies to supply each MicroLogic trip unit. You can use the same 24 Vdc power supply to supply the ULP modules in several Intelligent Modular Units (IMU).
- Use a separate 24 Vdc power supply to supply the MN or MX voltage releases.

Recommended 24 Vdc Power Supply

The following 24 Vdc power supply is recommended for use with ComPacT NS devices. For more information, refer to the *ComPacT NS Catalogue*.

Characteristic	AD power supply
Illustration	
Overvoltage category defined by IEC 60947-1	<ul style="list-style-type: none"> • Category IV per IEC 62477-1 (Vac model) • Category III per IEC 62477-1 (Vdc model) • Category III per UL 61010-1
Input supply voltage AC	<ul style="list-style-type: none"> • 110–130 Vac • 200–240 Vac
Input supply voltage DC	<ul style="list-style-type: none"> • 24–30 Vdc • 48–60 Vdc • 100–125 Vdc
Dielectric withstand	Input/output: <ul style="list-style-type: none"> • 3 kV RMS for 1 minute (110–130 Vac and 200–240 Vac model) • 3 kV RMS for 1 minute (110–125 Vdc model) • 2 kV RMS for 1 minute (24–30 Vdc and 48–60 Vdc model)
Temperature	70 °C (158 °F)
Output current	1 A
Ripple	200 mV peak-peak
Output voltage setting for line loss compensation	22.8–25.2 Vdc

24 Vdc Backup Battery

If the 24 Vdc power supply is interrupted, a 24 Vdc backup battery can be used to maintain the operation of the MicroLogic trip unit. It is installed in series between the MicroLogic trip unit and the 24 Vdc power supply module.

The 24 Vdc backup battery must have the following characteristics (compatible with the MicroLogic trip unit):

- Output voltage 17–28.8 Vdc
 - Cut-off voltage 17 Vdc (24 Vdc backup battery must have a shutdown output voltage in case of low voltage level)
 - Hysteresis > 3 Vdc (to avoid power-on before the voltage is up to 21 Vdc)
- 24 Vdc backup battery should be able to power an Inrush current of 10 A

Internal Battery

When no other power supply is supplying the MicroLogic trip unit, the internal battery powers the trip cause LEDs.

ULP Module Consumption

The same power supply can be used to supply the ULP modules of several intelligent modular units (IMU).

The following table lists the ULP module consumption:

Module	Typical consumption (24 Vdc at 20 °C/68 °F)	Maximum consumption (19.2 Vdc at 60 °C/140 °F)
BCM ULP circuit breaker communication module for MasterPact NT/NW and ComPact NS circuit breakers	40 mA	300 mA
IFE Ethernet interface for one circuit breaker	100 mA	140 mA
IFE Ethernet switchboard server	100 mA	140 mA
IFM Modbus-SL interface or one circuit breaker	21 mA	30 mA
FDM121 front display module for one circuit breaker	21 mA	30 mA

Thermal Memory

Presentation

The thermal memory is the means to take into account temperature rise and cooling caused by changes in the flow of current in the conductors.

These changes may be caused by:

- Repetitive motor starting
- Loads fluctuating near the long-time protection settings
- Repeated circuit-breaker closing on a fault.

Trip units without a thermal memory (contrary to bimetal strip thermal protection) do not react to the above types of overloads because they do not last long enough to cause tripping. However, each overload produces a temperature rise and the cumulative effect can lead to dangerous overheating.

Trip units with a thermal memory record the temperature rise caused by each overload, even those that are very short. This information stored in the thermal memory reduces the tripping time.

MicroLogic Trip Units and Thermal Memory

All MicroLogic trip units are equipped as standard with a thermal memory.

For all protection functions, prior to tripping, the temperature-rise and cooling time constants are equal and depend on the t_r time delay:

- If the time delay is short, the time constant is low.
- If the time delay is long, the time constant is high.

For long-time protection, following tripping, the cooling curve is simulated by the trip unit. Closing of the circuit breaker prior to the end of the time constant (approximately 15 minutes) reduces the tripping time indicated in the tripping curves.

Short-Time Protection and Intermittent Faults

For the short-time protection function, intermittent currents that do not provoke tripping are stored in the MicroLogic memory.

This information is equivalent to the long-time thermal memory and reduces the time delay for the short-time protection.

Following a trip, the short-time t_{sd} time delay is reduced to the value of the minimum setting for 20 seconds.

Ground-Fault Protection and Intermittent Faults

The ground-fault protection implements the same intermittent fault function as the short-time protection.

Calculating Demand Values (MicroLogic E)

Presentation

The MicroLogic E trip unit calculates and displays:

- the demand values of phase and neutral currents,
- the demand value of the total active power.

The maximum (peak) demand current and power values are stored in the memory. All demand values are updated once every minute.

Definition

The demand value of a quantity is its average value over a given period of time. In electrical power systems, it is used especially for the current and power. The demand value should not be confused with the instantaneous value or the average (or mean) value, which often refers to the average (or mean) of the instantaneous values of the 3 phases.

Calculation Interval

The time interval (or window) over which the average is calculated can be of 2 types:

- **Fixed window**

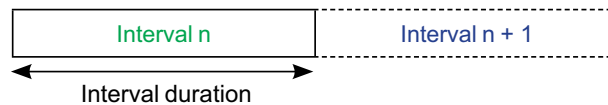

At the end of a fixed metering window:

- the demand value over the window is calculated and updated,
- the new demand value is initialized over a new window, starting from the end of the last window.

- **Sliding window**

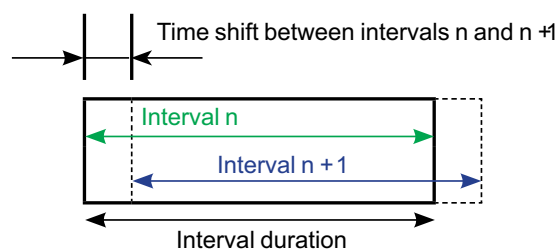

At the end of a sliding window:

- The demand value over the window is calculated and updated.
- The new demand value is initialized over a new window, starting from a given time after the start of the last window (always less than the duration of the window).

The duration of the sliding window can be set separately for current and power demand from 5 to 60 minutes in 1 minute steps (refer to [Measurement Settings](#), page 43). The default setting is 15 minutes.

The time shift between intervals is equal to 1 minute.

Calculation Method

MicroLogic E trip units use the quadratic model to calculate both demand current and demand power.

The quadratic demand calculation model represents the conductor heat rise (thermal image).

The heat rise created by the current $I(t)$ over the time interval T is identical to that created by a constant current I_{th} over the same interval. This current I_{th} represents the thermal effect of the current $I(t)$ over the interval T .

Calculation of the demand value according to the thermal model must be always performed on a sliding window.

NOTE: The thermal demand value is similar to an rms value.

Peak Demand Values

The MicroLogic E trip unit calculates:

- the maximum (peak) demand values of phase and neutral currents since the last reset,
- the maximum (peak) demand values of total active power since the last reset.

The peak demand values can be accessed and/or reset in the following ways:

- Peak demand current: via the MicroLogic trip unit (see the detailed topic, page 32) or the communication option, page 70.
- Peak demand power: via the communication option, page 70.

Measurement Ranges and Accuracy

The accuracy of the current measurements depends on both the value displayed (or transmitted) and the circuit-breaker rating (I_n):

- Below $0.1 \times I_n$, measurements are not significant
- Between $0.1 \times I_n$ and $0.2 \times I_n$, accuracy changes linearly from 4 % to 1.5 %
- Between $0.2 \times I_n$ and $1.2 \times I_n$, accuracy = 1.5 %

The resolution for the current is one Ampere.

The resolution for the voltage is one Volt.

The resolution for power is one kW, kVar, kVA.

The resolution for energy is one kWh, kVarh, kVAh.

Measurement		MicroLogic	Accuracy at 25 °C	Measurement range for specified accuracy
Instantaneous current	I1, I2, I3	A, E	±1.5 %	$0.2 \times I_n \dots 1.2 \times I_n$
	I_N	A, E	±1.5 %	$0.2 \times I_n \dots 1.2 \times I_n$
	I_{\perp} ground	A, E	±10 %	$0.2 \times I_n \dots I_n$
	I_{\perp} earth leakage	A, E	±1.5 %	0 to 30 A
Current maximeters	I1 max, I2 max, I3 max	A, E	±1.5 %	$0.2 \times I_n \dots 1.2 \times I_n$
	I_N max	A, E	±1.5 %	$0.2 \times I_n \dots 1.2 \times I_n$
Demand current	$\overline{I_1}, \overline{I_2}, \overline{I_3}$	A, E	±1.5 %	$0.2 \times I_n \dots 1.2 \times I_n$
	$\overline{I_N}$	A, E	±1.5 %	$0.2 \times I_n \dots 1.2 \times I_n$
Demand current maximeters	$\overline{I_1}$ max, $\overline{I_2}$ max, $\overline{I_3}$ max	A, E	±1.5 %	$0.2 \times I_n \dots 1.2 \times I_n$
	$\overline{I_N}$ max	A, E	±1.5 %	$0.2 \times I_n \dots 1.2 \times I_n$
Phase-to-phase voltages (3 and 4-wire systems)	V12	E	±0.5 %	100 ... 690 V
	V23	E	±0.5 %	100 ... 690 V
	V31	E	±0.5 %	100 ... 690 V
Phase-to-neutral voltages (4-wire systems)	V1N	E	±0.5 %	100 ... 690 V
	V2N	E	±0.5 %	100 ... 690 V
	V3N	E	±0.5 %	100 ... 690 V
Average voltage	Vavg	E	±0.5 %	0 ... 100 %
Voltage unbalance	U unbal	E	±0.5 %	0 ... 100 %
Instantaneous power	P (per phase)	E	±2 %	30...2000 kW
	Q (per phase)	E	±2 %	30...2000 kVar
	S (per phase)	E	±2 %	30...2000 kVA
Power maximeters	P max (per phase)	E	±2 %	30...2000 kW
	Q max (per phase)	E	±2 %	30...2000 kVar
	S max (per phase)	E	±2 %	30...2000 kVA
Demand power	P (per phase)	E	±2 %	30...2000 kW
	S (per phase)	E	±2 %	30...2000 kVA
Demand power maximeters	P max (per phase)	E	±2 %	30...2000 kW
Instantaneous power factor	PF	E	±2 %	0 ... +1

Measurement		MicroLogic	Accuracy at 25 °C	Measurement range for specified accuracy
Total energy	Ep	E	±2 %	-1010 GWh ... +1010 GWh
	Eq	E	±2 %	-1010 GVArh ... +1010 GVArh
	Es	E	±2 %	-1010 GVAh ... +1010 GVAh

Schneider Electric
35 rue Joseph Monier
92500 Rueil Malmaison
France

+ 33 (0) 1 41 29 70 00

www.se.com

As standards, specifications, and design change from time to time,
please ask for confirmation of the information given in this publication.

© 2022 Schneider Electric. All rights reserved.

DOCA0218EN-00