

# TeSys Giga Series

## TeSys Control-Giga Contactors

## TeSys Protect-Giga Electronic Overload Relays

### Installation and User Guide

TeSys offers innovative and connected solutions for motor starters.

Original instructions

DOCA0189EN-06  
11/2025



# Legal Information

The information provided in this document contains general descriptions, technical characteristics and/or recommendations related to products/solutions.

This document is not intended as a substitute for a detailed study or operational and site-specific development or schematic plan. It is not to be used for determining suitability or reliability of the products/solutions for specific user applications. It is the duty of any such user to perform or have any professional expert of its choice (integrator, specifier or the like) perform the appropriate and comprehensive risk analysis, evaluation and testing of the products/solutions with respect to the relevant specific application or use thereof.

The Schneider Electric brand and any trademarks of Schneider Electric SE and its subsidiaries referred to in this document are the property of Schneider Electric SE or its subsidiaries. All other brands may be trademarks of their respective owner.

This document and its content are protected under applicable copyright laws and provided for informative use only. No part of this document may be reproduced or transmitted in any form or by any means (electronic, mechanical, photocopying, recording, or otherwise), for any purpose, without the prior written permission of Schneider Electric.

Schneider Electric does not grant any right or license for commercial use of the document or its content, except for a non-exclusive and personal license to consult it on an "as is" basis.

Schneider Electric reserves the right to make changes or updates with respect to or in the content of this document or the format thereof, at any time without notice.

**To the extent permitted by applicable law, no responsibility or liability is assumed by Schneider Electric and its subsidiaries for any errors or omissions in the informational content of this document, as well as any non-intended use or misuse of the content thereof.**

# Table of Contents

Safety Information .....	5
About the Document .....	6
Precautions.....	9
Introduction to TeSys Giga Series .....	10
TeSys Master Range.....	11
TeSys Control-Giga Contactors.....	12
Overview .....	12
Utilization Categories .....	16
Hardware Description .....	20
Diagnosis Functions .....	23
Control Mode .....	25
TeSys Protect-Giga Electronic Overload Relays .....	28
Overview .....	28
Hardware Description .....	29
Current-Based Protection Functions .....	33
Thermal Overload Protection .....	34
Phase Loss Protection.....	38
Phase Imbalance Protection .....	39
Ground Fault Protection.....	40
Go2SE Landing Page.....	41
Technical Characteristics .....	46
Dimensions .....	47
Weights.....	53
Thermal Dissipation .....	54
Contactors Technical Characteristics.....	55
LC1G250DC Pole Characteristics .....	61
DC Control Module Characteristics.....	64
Overload Relays Technical Characteristics .....	65
Contactor Accessory Technical Characteristics .....	67
Electromagnetic Compatibility.....	68
Short-Circuit Current Ratings (SCCR) .....	69
Installation .....	71
Contactor Customization .....	72
TeSys Giga Contactor Mounting on Plate.....	75
TeSys Giga Electronic Overload Relay Mounting on Plate.....	79
TeSys Giga Contactor Mounting on Retrofit Base .....	81
TeSys Giga Contactor and TeSys Giga Overload Relay Direct Mounting .....	85
TeSys Giga Contactor Assembly with TeSys Giga Overload Relay Separately Mounted.....	92
Identification with Clip-On Marker Holder .....	94
Wiring.....	95
Wiring Precautions.....	96
Power Connections.....	97
Connection with Bars.....	97
Connection with Lugs .....	99
Connection with Box Connectors.....	102
Power Connection Accessories.....	103

Straight Terminal Extensions .....	104
Edgewise Terminal Extensions .....	106
L Side Terminal Extensions .....	108
L Large Terminal Extension .....	109
L Rear Terminal Extension .....	111
Spreaders.....	112
Large Spreaders .....	114
Flexible Terminal Extensions .....	116
Terminal Adapters for Box Connector.....	117
Installation of the Power Connection Accessories .....	119
Bar or Lug Connection .....	119
Installation of the Box Connectors .....	120
Control Connections .....	121
Installation of Accessories .....	123
DC Coupling Bar .....	124
Insulation Accessories.....	126
Terminal Shrouds .....	126
Phase Separator .....	134
Functional Accessories .....	138
Auxiliary Contact Modules.....	138
Remote Wear Diagnostic Module .....	142
Remote Diagnostic Modbus Module .....	146
Applications .....	155
Safety Applications .....	156
Single-Phase Motor Application .....	161
Star-Delta Starters .....	162
Two Contactors Reverser .....	178
Two Contactors Changeover.....	184
Maintenance .....	190
Safety Instructions .....	191
Switching Module Replacement .....	192
Control Module Replacement.....	201
Cybersecurity .....	206
Troubleshooting .....	208

# Safety Information

## Important Information

### NOTICE

Read these instructions carefully, and look at the equipment to become familiar with the device before trying to install, operate, service, or maintain it. The following special messages may appear throughout this documentation or on the equipment to warn of potential hazards or to call attention to information that clarifies or simplifies a procedure.



The addition of this symbol to a “Danger” or “Warning” safety label indicates that an electrical hazard exists which will result in personal injury if the instructions are not followed.



This is the safety alert symbol. It is used to alert you to potential personal injury hazards. Obey all safety messages that follow this symbol to avoid possible injury or death.

<b>⚠ DANGER</b>
<b>DANGER</b> indicates a hazardous situation which, if not avoided, <b>will result in</b> death or serious injury.

<b>⚠ WARNING</b>
<b>WARNING</b> indicates a hazardous situation which, if not avoided, <b>could result in</b> death or serious injury.

<b>⚠ CAUTION</b>
<b>CAUTION</b> indicates a hazardous situation which, if not avoided, <b>could result in</b> minor or moderate injury.

<b>NOTICE</b>
<b>NOTICE</b> is used to address practices not related to physical injury.

### PLEASE NOTE

Electrical equipment should be installed, operated, serviced and maintained only by qualified personnel. No responsibility is assumed by Schneider Electric for any consequences arising out of the use of this material.

A qualified person is one who has skills and knowledge related to the construction, installation, and operation of electrical equipment and has received safety training to recognize and avoid the hazards involved.

# About the Document

## Document Scope

Use this guide to:

- Familiarize yourself with the mechanical and electrical characteristics of the components of TeSys Giga Series:
  - TeSys™ Control-Giga Contactors
  - TeSys™ Protect-Giga Electronic Overload Relays
- Assemble and wire the contactors and overload relays.

## Validity Note

This installation guide is valid for TeSys Control-Giga Contactors and TeSys Protect-Giga Electronic Overload Relays with configurations as mentioned below:

- 3-pole and 4-pole contactors:
  - 10 AC-3 ratings in 3 sizes:
    - 115–150–185–225 A
    - 265–330–400–500 A
    - 630–800 A
  - 1 DC-1 rating in 1 size:
    - 250 A
  - 3 types of contactors:
    - TeSys Giga Contactors - Advanced version
    - TeSys Giga Contactors - Standard version
    - TeSys Giga Contactors - DC Version
- Overload relays: 4 current rating ranges in 3 sizes:
  - 28–115 A and 57–225 A
  - 125–500 A
  - 160–630 A

The availability of some functions described in this guide depends on physical modules installed on the contactors and overload relays.

## Environmental data

For product compliance and environmental information, refer to the Schneider Electric Environmental Data Program.

## Online Information

The information contained in this document is likely to be updated at any time. Schneider Electric strongly recommends that you have the most recent and up-to-date version available on [www.se.com/ww/en/download](http://www.se.com/ww/en/download).

The technical characteristics of the devices described in the present document also appear online. To access the information online, go to the Schneider Electric home page [www.se.com](http://www.se.com).

The technical characteristics presented in this guide should be the same as those that appear online. If you see a difference between the information contained in this guide and online information, use the online information.

For product compliance with environmental directives such as RoHS, REACH, PEP, and EOL, go to [www.se.com/green-premium](http://www.se.com/green-premium).

## Available Languages of the Document

The document is available in these languages:

- English (DOCA0189EN)
- French (DOCA0189FR)
- Spanish (DOCA0189ES)
- German (DOCA0189DE)
- Chinese (DOCA0189ZH)
- Italian (DOCA0189IT)
- Russian (DOCA0189RU)
- Portuguese (DOCA0189PT)

## Related Documentation

Document title	Description	Document number
<i>TeSys Control - Giga Contactors and TeSys Protect - Giga Electronic Overload Relays Catalogue</i>	Describes about the contactors and overload relays	LVCATESG_EN
<i>TeSys Control Giga Series – Contactors – Instruction Sheet</i>	Describes how to install the contactors	GDE2324401
<i>TeSys Protect Giga Series – Electronic Thermal Overload Relays – Instruction Sheet</i>	Describes how to install the overload relays	NNZ5249001
<i>TeSys Control Giga Series – Auxiliary Contacts with Push-in Terminals – Instruction Sheet</i>	Describes how to install the auxiliary contacts with push-in terminals	NNZ5266201
<i>TeSys Control Giga Series – Retrofit Kit for Contactors – Instruction Sheet</i>	Describes how to mount the contactors on plate using the retrofit kit	NNZ4443401
<i>TeSys Control Giga Series – Remote Wear Diagnostic Module – Instruction Sheet</i>	Describes how to mount the remote wear diagnostic module	NNZ4807901
<i>TeSys Control Giga Series – Power Connection Accessories – Instruction Sheet</i>	Describes how to mount the power connection accessories	NNZ4793901
<i>TeSys Control Giga Series - Flexible Terminal Extensions - Instruction Sheet</i>	Describes how to connect a moulded case circuit breaker to a LC1G contactors	NNZ9700101
<i>TeSys Control Giga Series – Cable Memory – Instruction Sheet</i>	Describes how to mount the cable memory	NNZ5141101
<i>TeSys Control Giga Series – Control Module – Instruction Sheet</i>	Describes how to mount the control module	NNZ5142501
<i>TeSys Control Giga Series – Switching Module – Instruction Sheet</i>	Describes how to mount the switching module	NNZ5266601
<i>TeSys Control Giga Series – IP20 Terminal Shrouds for LC1G115-500 Contactors – Instruction Sheet</i>	Describes how to mount IP20 terminal shrouds on LC1G115-500 contactors	NNZ4804701
<i>TeSys Control Giga Series - IP20 Terminal Shrouds for LC1G630-800 Contactors - Instruction Sheet</i>	Describes how to mount IP20 terminal shrouds on LC1G630-800 contactors	JYT9976501
<i>TeSys Control Giga Series – Combination Accessories – Instruction Sheet</i>	Describes how to mount the mechanical interlock and coupling bars	NNZ4813501

Document title	Description	Document number
<i>TeSys Control Giga Series – Phase Separator – Instruction Sheet</i>	Describes how to mount the phase separator	JYT2250601
<i>TeSys Control Giga Series – Push-in Terminal Adapter – Instruction Sheet</i>	Describes how to mount the push-in terminal adapter	NNZ5142001
<i>TeSys Control Giga Series – Remote Diagnosis Modbus Module – Instruction Sheet</i>	Describes how to mount the remote diagnosis modbus module	GEX3750201
<i>TeSys Protect Giga Series – Mounting Base – Instruction Sheet</i>	Describes how to mount the stand alone overload relay on the mounting base	NNZ4806801

## Trademarks

*QR Code* is a registered trademark of DENSO WAVE INCORPORATED in Japan and other countries.

## Precautions

Read and understand the following precautions before performing any procedures in this guide.

### **DANGER**

#### **HAZARD OF ELECTRIC SHOCK, EXPLOSION, OR ARC FLASH**

- Apply appropriate personal protective equipment (PPE) and follow safe electrical work practices. See NFPA 70E, CSA Z462, NOM 029-STPS or local equivalent.
- This equipment must only be installed and serviced by qualified electrical personnel.
- Turn off all power supplying this equipment before working on this equipment.
- Use only the specified voltage when operating this equipment and any associated products.
- Power line circuits must be wired and protected in compliance with local and national regulatory requirements.
- Beware of potential hazards, and carefully inspect the work area for tools and objects that may have been left inside the equipment.

**Failure to follow these instructions will result in death or serious injury.**

## California Proposition 65 Warning

 **WARNING:** This product can expose you to chemicals including Styrene, which is known to the State of California to cause cancer and to Bisphenol A, which is known to the State of California to cause birth defects or other reproductive harm. For more information go to [www.P65Warnings.ca.gov](http://www.P65Warnings.ca.gov).

## Intended Use

The products described in this guide are low voltage switchgears intended for industrial use within industrial or commercial applications.

The product may only be used in compliance with all applicable safety regulations and directives, the specified requirements, and the technical data.

Before using the product, you must perform a hazard analysis and risk assessment of the planned application. Based on the results, appropriate safety related measures must be implemented.

Since the product is used as a component of a machine or process, you must ensure the safety of persons by means of the overall system design.

Operate the product only with the specified cables and accessories. Use only genuine accessories and spare parts. Any use other than the use explicitly permitted is prohibited and can result in unanticipated hazards.

# Introduction to TeSys Giga Series

## What's in This Chapter

TeSys Master Range .....	11
TeSys Control-Giga Contactors .....	12
TeSys Protect-Giga Electronic Overload Relays.....	28
Go2SE Landing Page .....	41

## TeSys Master Range

TeSys is an innovative motor control and management solution from the global market leader. TeSys offers connected, efficient products and solutions for switching and protection of motors and electrical loads in compliance with all major global electrical standards.

# TeSys Control-Giga Contactors

## Overview

TeSys Control-Giga contactors are high power contactors (up to 800 A AC-3 or 1050 A AC-1) for AC/DC motor applications and AC/DC load applications. They can be used up to 1000 Vac power voltage and up to 460 Vdc power voltage.

They are available with 3 main poles or 4 main poles that have the same width and the same pole pitch as the associated Schneider Electric circuit breaker.

They can be supplied either by AC or DC control voltage and has the built-in surge suppressors. They can operate with a wide control voltage band. If they are supplied by DC control voltage, there is no need to respect the polarity.

They embed diagnosis functions as contact wear diagnosis or control voltage diagnosis. They are delivered with one auxiliary contact module of two auxiliary contacts (1 NO + 1 NC) with push-in terminals. The auxiliary NC contact mirrors the state of the main poles and the auxiliary NO contact is mechanically linked to the NC auxiliary contact.

There are three versions of contactors:

- TeSys Giga Contactors – Advanced Version
  - Advanced contactor for general application
  - Advanced contactor for railway application
- TeSys Giga Contactors – Standard Version
  - Standard contactor for general application
  - Standard contactor for railway application
- TeSys Giga Contactors – DC Version

## TeSys Giga Contactors – Advanced Version for General Application

The specific mechanical design of the advanced contactor allows contactor maintenance without removing the power circuit connections.

On advanced contactors, the advanced control module controls the contactor by A1-A2 terminals or by X1-X2-X3 PLC inputs terminals. The X1-X2-X3 terminals directly controls the contactor by high density PLC solid output without an interposing relay.

They can operate with 24-48, 48-130, or 200-500 Vac/Vdc control voltage ranges. All control terminals are removable and use push-in technology. The advanced control module is compatible with the optional Remote Wear Diagnosis (RWD) module.

## TeSys Giga Contactors – Advanced Version for Railway Application S207

Advanced contactors with commercial references ending with S207A are dedicated to railway applications.

The advanced control module controls the contactor by A1-A2 terminals or by X1-X2-X3 PLC inputs terminals. The X1-X2-X3 terminals directly controls the contactor by high density PLC solid output without an interposing relay.

They can operate with 48-130 Vac/Vdc control voltage ranges. All control terminals are removable and use push-in technology. The advanced control module is compatible with the optional Remote Wear Diagnosis (RWD) module.

## Tesys Giga Contactors – Standard Version for General Application

On standard contactors, the standard control module controls the contactor by A1-A2 terminals. They can operate with 48-130, 100-250, 200-500 or 600 Vac/Vdc control voltage ranges. The A1-A2 terminals are removable and use push-in technology.

## Tesys Giga Contactors – Standard Version for Railway Application S207

Standard contactors with commercial references ending with S207N are dedicated to railway applications.

The standard control module controls the contactor by A1-A2 terminals. They can operate with 48-130, 200-500 Vac/Vdc control voltage range only. The A1-A2 terminals are removable and use push-in technology.

## Tesys Giga Contactors – DC Version

Contactors with commercial references containing DC are dedicated to DC applications.

The control module controls the contactor by A1-A2 terminals. They can operate with 24-48, 48-130, 100-250, 200-500 Vac/Vdc control voltage range only. The A1-A2 terminals are removable and use push-in technology.

## Coding Principle

The commercial reference of TeSys Giga contactors is coded with significant features to explain the type of contactor, current ratings at 440 Vac for AC-3 utilization category, control voltage and number of poles.

### Contactors for General Application

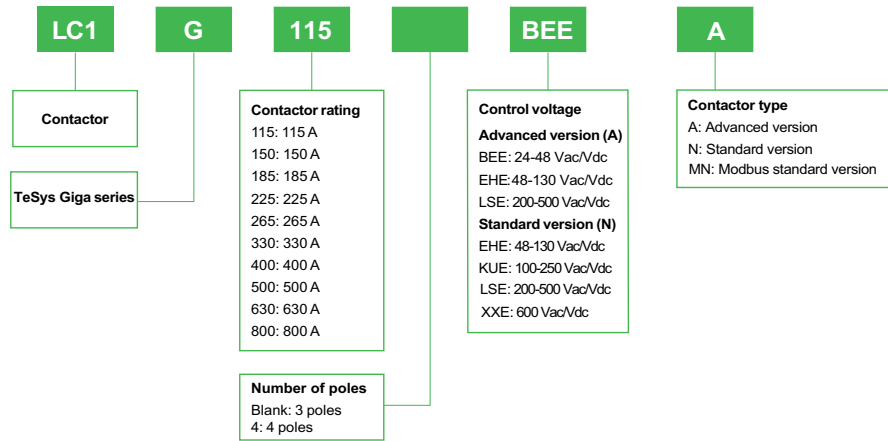

**NOTE:**

- BEE control voltage option is available on advanced contactors LC1G115-500.
- Modbus standard version supports Remote Diagnostic Modbus (RDM) Module. MN option is available for 3-pole contactors with LSE control voltage.

### Contactors for Railway Application

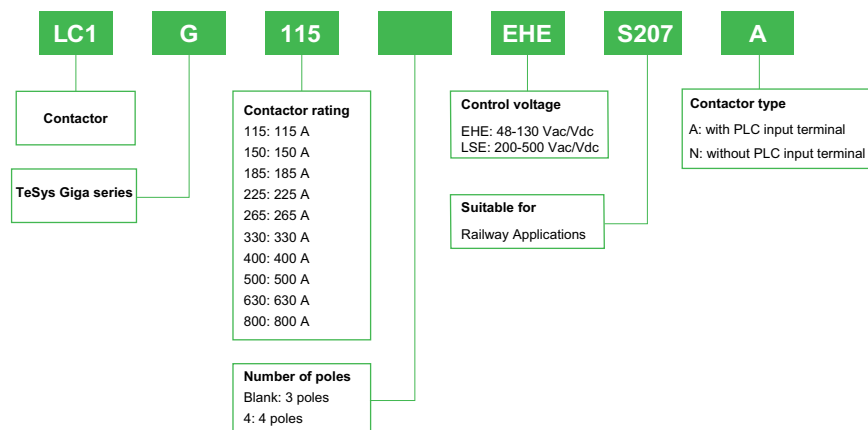

**NOTE:** LSE control voltage option is available for LC1G630-800.

## Contactors for DC Application

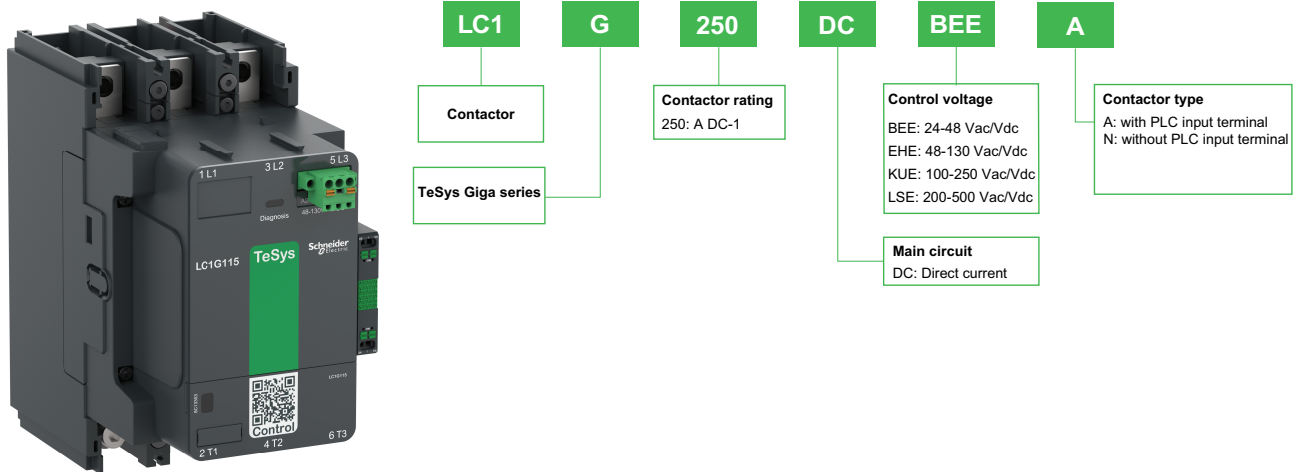

### NOTE:

- PLC input terminal is available on contactors with BEE control voltage.
- Only 3-pole contactors are available.

## Utilization Categories

The contactors are designed to switch AC or DC loads. The IEC 60947-4-1 and UL 60947-4-1 standards define the utilization categories for a contactor.

The table below provides the definition of the AC utilization categories:

Term	Definition
AC-1	Non-inductive or slightly inductive loads, resistance furnaces
AC-2	Slip-ring motors: starting, switching off
AC-3	Squirrel-cage motors: starting, switching off motors during running, reversing
AC-3e	Squirrel-cage motors with higher locked rotor current: starting, switching off motors during running, reversing
AC-4	Squirrel-cage motors: starting, plugging, inching
AC-5a	Switching of electric discharge lamp controls
AC-5b	Switching of incandescent lamps
AC-6a	Switching of transformers
AC-6b	Switching of capacitor banks
AC-7a	Slightly inductive loads in household appliances and similar applications
AC-7b	Motor-loads for household applications
AC-8a	Hermetic refrigerant compressor motor control with manual resetting of overload releases
AC-8b	Hermetic refrigerant compressor motor control with automatic resetting of overload releases

The table below provides the definition of the DC utilization categories:

Term	Definition
DC-1	Non-inductive or slightly inductive loads
DC-3	Shunt-motors: starting, plugging, inching, dynamic breaking of DC motors
DC-5	Series-motors: starting, plugging, inching, dynamic breaking of DC motors

## Motor Ratings per IEC Utilization Categories

The table below indicates the motor ratings compatible with the 3-pole and 4-pole advanced and standard contactors for AC-3, AC-3e, and AC-4 utilization categories.

Contactors	Category	230 Vac	400 Vac	415 Vac	440 Vac	500 Vac	690 Vac	1000 Vac
<b>LC1G115</b>	AC-3	30 kW	55 kW	55 kW	75 kW	75 kW	75 kW	-
<b>LC1G1154</b>	AC-3e	30 kW	55 kW	55 kW	75 kW	75 kW	75 kW	-
	AC-4	30 kW	55 kW	55 kW	65 kW	65 kW	75 kW	-
<b>LC1G150</b>	AC-3	37 kW	75 kW	75 kW	90 kW	90 kW	90 kW	75 kW
<b>LC1G1504</b>	AC-3e	37 kW	75 kW	75 kW	90 kW	90 kW	90 kW	75 kW
	AC-4	37 kW	75 kW	75 kW	80 kW	90 kW	90 kW	75 kW
<b>LC1G185</b>	AC-3	55 kW	90 kW	90 kW	110 kW	110 kW	110 kW	75 kW
<b>LC1G1854</b>	AC-3e	55 kW	90 kW	90 kW	110 kW	110 kW	110 kW	75 kW
	AC-4	55 kW	90 kW	90 kW	100 kW	110 kW	110 kW	75 kW
<b>LC1G225</b>	AC-3	55 kW	110 kW	110 kW	132 kW	132 kW	160 kW	132 kW
<b>LC1G2254</b>	AC-3e	55 kW	110 kW	110 kW	132 kW	132 kW	160 kW	132 kW
	AC-4	55 kW	110 kW	110 kW	129 kW	132 kW	132 kW	110 kW
<b>LC1G265</b>	AC-3	75 kW	132 kW	132 kW	160 kW	160 kW	200 kW	160 kW
<b>LC1G2654</b>	AC-3e	75 kW	132 kW	132 kW	160 kW	160 kW	200 kW	160 kW
	AC-4	75 kW	132 kW	132 kW	150 kW	160 kW	160 kW	160 kW
<b>LC1G330</b>	AC-3	90 kW	160 kW	160 kW	200 kW	200 kW	220 kW	185 kW
<b>LC1G3304</b>	AC-3e	90 kW	160 kW	160 kW	185 kW	200 kW	220 kW	185 kW
	AC-4	90 kW	160 kW	160 kW	185 kW	200 kW	220 kW	185 kW
<b>LC1G400</b>	AC-3	110 kW	200 kW	200 kW	250 kW	250 kW	315 kW	220 kW
<b>LC1G4004/5004</b>	AC-3e	110 kW	200 kW	200 kW	250 kW	250 kW	315 kW	220 kW
	AC-4	110 kW	200 kW	200 kW	220 kW	250 kW	315 kW	220 kW
<b>LC1G500</b>	AC-3	160 kW	250 kW	250 kW	315 kW	355 kW	355 kW	335 kW
<b>LC1G6304</b>	AC-3e	147 kW	250 kW	250 kW	280 kW	315 kW	355 kW	335 kW
	AC-4	150 kW	250 kW	250 kW	295 kW	295 kW	355 kW	280 kW
<b>LC1G630</b>	AC-3	200 kW	335 kW	375 kW	400 kW	400 kW	500 kW	450 kW
<b>LC1G8004</b>	AC-3e	180 kW	315 kW	335 kW	355 kW	375 kW	500 kW	450 kW
	AC-4	180 kW	315 kW	335 kW	355 kW	375 kW	450 kW	355 kW
<b>LC1G800</b>	AC-3	250 kW	450 kW	450 kW	500 kW	500 kW	560 kW	450 kW
	AC-3e	200 kW	335 kW	355 kW	375 kW	425 kW	560 kW	450 kW
	AC-4	200 kW	375 kW	355 kW	375 kW	400 kW	475 kW	400 kW

## Motor Ratings per UL/CSA Standards

The table below indicates the UL/CSA certified motor ratings for the 3-pole and 4-pole advanced and standard contactors according to UL/CSA standards.

Contactors	200-208 V	220-240 V	440-480 V	550-600 V
LC1G115 LC1G1154	30 hp	40 hp	75 hp	100 hp
LC1G150 LC1G1504	40 hp	50 hp	100 hp	125 hp
LC1G185 LC1G1854	50 hp	60 hp	125 hp	150 hp
LC1G225 LC1G2254	60 hp	75 hp	150 hp	150 hp
LC1G265 LC1G2654	75 hp	100 hp	200 hp	200 hp
LC1G330 LC1G3304	100 hp	125 hp	250 hp	300 hp
LC1G400 LC1G4004	125 hp	150 hp	300 hp	400 hp
LC1G500 LC1G5004	150 hp	200 hp	400 hp	450 hp
LC1G630 LC1G6304	250 hp	300 hp	600 hp	700 hp
LC1G800 LC1G8004	300 hp	350 hp	700 hp / 828 FLA	800 hp / 754 FLA

## Loads per IEC Utilization Category and UL/CSA Standards

The table below indicates the loads compatible with the 3-pole and 4-pole advanced and standard contactors for IEC AC-1 utilization category and according to UL/CSA standard.

Contactors	IEC AC-1 utilization category	IEC AC-1 utilization category	UL/CSA general purpose
	Maximum current ( $\theta \leq 40\text{ °C} / 104\text{ °F}$ )	Maximum current ( $\theta \leq 60\text{ °C} / 140\text{ °F}$ )	Continuous current
LC1G115 LC1G1154	250 A	225 A	210 A
LC1G150 LC1G1504	275 A	250 A	230 A
LC1G185 LC1G1854	305 A	275 A	250 A
LC1G225 LC1G2254	330 A	300 A	290 A
LC1G265 LC1G2654	385 A	350 A	340 A
LC1G330 LC1G3304	440 A	400 A	390 A
LC1G400 LC1G4004	550 A	500 A	490 A
LC1G500 LC1G5004	700 A	600 A	630 A
LC1G630 LC1G6304	1050 A	800 A	850 A
LC1G800 LC1G8004	1050 A	800 A	900 A

## Hardware Description

### Advanced and Standard Version Contact

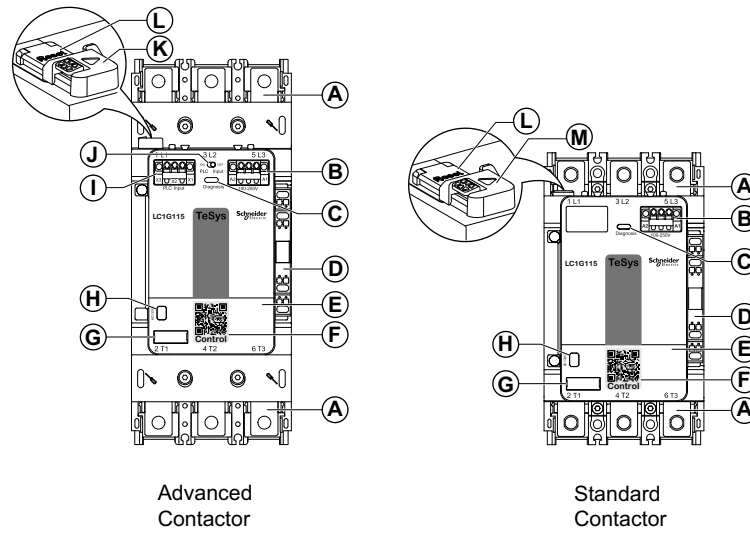

Labels	Description
A	Power connections
B	A1–A2 control module terminal
C	Diagnosis orange LED
D	1 NO + 1 NC auxiliary contacts
E	Marking flap cover
F	QR code
G	Clip-on marker holder
H	ON/OFF status indicator
I	PLC input terminal (X1–X2–X3)
J	PLC input ON/OFF switch
K	Remote wear diagnosis module plug (available on advanced contactor only)
L	Diagnosis reset switch
M	Remote diagnosis Modbus module plug (available on Standard contactors LC1G115–800LSEMN only)

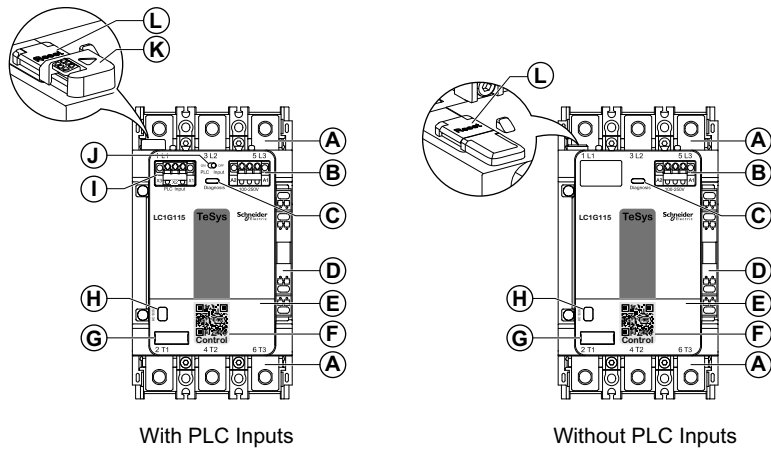
**DC Version Contact**

Labels	Description
A	Power connections
B	A1–A2 control module terminal
C	Diagnosis orange LED
D	1 NO + 1 NC auxiliary contacts
E	Marking flap cover
F	QR code
G	Clip-on marker holder
H	ON/OFF status indicator
I	PLC input terminal (X1–X2–X3)
J	PLC input ON/OFF switch
K	Remote wear diagnosis module plug
L	Diagnosis reset switch

## Diagnosis LED

The below table provides the different LED indication functions:

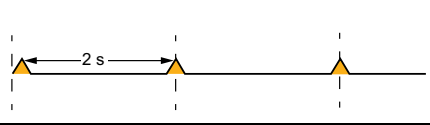
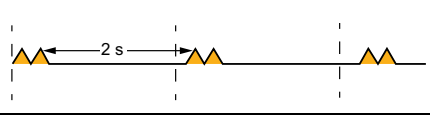
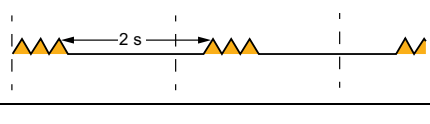
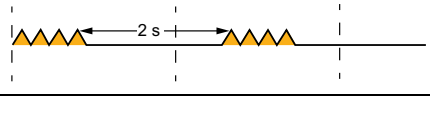
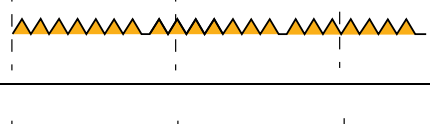
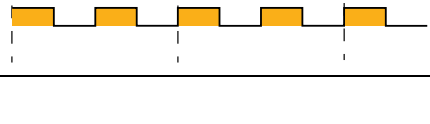
LED indication	Diagnosis indication	Diagnosis function
	The contacts are worn, see Diagnosis Functions, page 23	Diagnosis contact wear
	The control voltage is lower than 80 % of $U_{cmin}$ , see Diagnosis Functions, page 23	Under voltage
	The control voltage is higher than 110 % of $U_{cmax}$ , see Diagnosis Functions, page 23	Over voltage
	The remote wear diagnosis module is not synchronized with the contactor, see Diagnosis Functions, page 23	Remote wear diagnosis module synchronization
	The wear diagnosis reset is in progress, see Switching Module Replacement, page 196	Reset of remote wear diagnosis
	A control module internal malfunction is detected, see Troubleshooting, page 208	Internal functioning

## QR Code

When the QR code on the front face of a TeSys Giga series device is scanned with a smartphone having a QR code reader and connected to the internet, Go2SE Landing Page, page 41 is displayed. The landing page displays some information about the device and a list of menus.

## Diagnosis Functions

### Contact Wear Diagnosis

The contact wear increases every time the contactor breaks the current in the power circuit.

The contact wear algorithm embedded in the control module calculates the remaining service life of the contacts. When the remaining service life of the contacts is below 15%, it is indicated:

- locally by the Diagnosis LED on the front face of the contactor.
- remotely by the optional remote diagnosis Modbus module (LA9GRDMD) when a control module with commercial references ending with LSEMNI is installed. See [Remote Diagnostic Modbus Module](#), page 146.
- remotely by the optional remote wear diagnosis module, option available on advanced contactor only.

With this diagnosis indication, predictive maintenance can be planned for replacing the complete set of switching modules and avoiding breakdown maintenance.

For replacement of the switching modules and resetting the contact wear diagnosis, see [Switching Module Replacement](#), page 196.

### Control Voltage Diagnosis

The control voltage supplying the control module at A1-A2 is monitored.

With a control module with commercial references ending with LSEMNI, the diagnosis indication is available remotely with the optional RDM module. See [Remote Diagnostic Modbus Module](#), page 146

### Under Voltage

If the control voltage supplying the control module at A1-A2 is lower than 80 % of  $U_{cmin}$ , it is indicated by the Diagnosis LED flashing 2 times at repeated intervals.

$U_{cmin}$  is the minimum value of rated control voltage range ( $U_c$ ) of the control module.

Example: for a control module with  $U_c = 48-130 \text{ Vac/Vdc}$ ,  $U_{cmin} = 48 \text{ Vac/Vdc}$ .

If under voltage is detected, see [Troubleshooting](#), page 208.

### Over Voltage

If the control voltage supplying the control module at A1-A2 is higher than 110 % of  $U_{cmax}$ , it is indicated by the Diagnosis LED flashing 3 times at repeated intervals.

$U_{cmax}$  is the maximum value of rated control voltage range ( $U_c$ ) of the control module.

Example: for a control module with  $U_c = 48-130 \text{ Vac/Vdc}$ ,  $U_{cmax} = 130 \text{ Vac/Vdc}$ .

If over voltage is detected, see [Troubleshooting](#), page 208.

### Internal Functioning Diagnosis

The control module checks its correct internal functioning. If an internal malfunction is detected, it is indicated by the Diagnosis LED blinking. See [Troubleshooting](#), page 208

With a control module with commercial references ending with LSEM N, the diagnosis indication is available remotely with the optional RDM module. See Remote Diagnostic Modbus Module, page 146.

## Remote Wear Diagnosis Module Synchronization

The remote wear diagnosis module provides remote indication of the contact wear diagnosis. It is an option for advanced contactors only.

The state of the remote wear diagnosis is not consistent with the state of the contact wear diagnosis function of the control module when:

- the control module has detected that the contacts are worn, but the remote wear diagnosis module is in normal state
- the control module has not detected that the contacts are worn, but the remote wear diagnosis module is in alarm state

In both cases, the state of the remote wear diagnosis module is incorrect. It is indicated by the Diagnosis LED flashing 4 times regularly. See Troubleshooting, page 208.

## Control Module Temperature Diagnosis

Temperature of the control module with commercial references ending with LSEM N is monitored. If the temperature exceeds its operation limit, it can be indicated locally or remotely through the optional RDM module. See Remote Diagnostic Modbus Module, page 146.

## Contactors Operating Times Diagnosis

The control module with commercial references ending with LSEM N can count operating cycles of the contactor and communicates the number of operating cycles remotely through the optional RDM module. See Remote Diagnostic Modbus Module, page 146.

## Control Mode

<b>⚠ WARNING</b>
<b>UNINTENDED EQUIPMENT OPERATION</b>
Size the command components according to the control circuit characteristics.
<b>Failure to follow these instructions can result in death, serious injury, or equipment damage.</b>

## Advanced and DC Contactor with PLC Inputs

### With PLC input switch in the position OFF

A1-A2 control module terminals are used to control the advanced contactor. The control modes and the control wiring are the same as a standard contactor (see Standard contactor for detail)

X1-X2-X3 control module terminals are not used and do not need to be wired.

#### Two-wire mode: maintained command

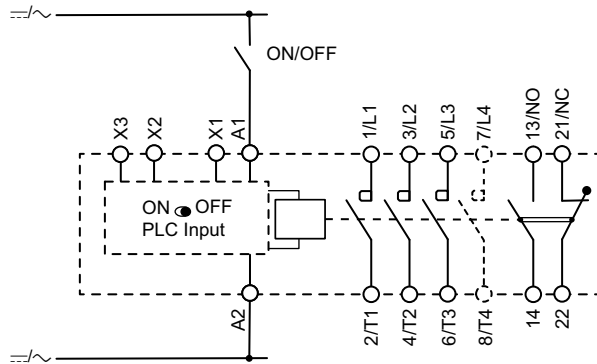

#### Three-wire mode: pulse command

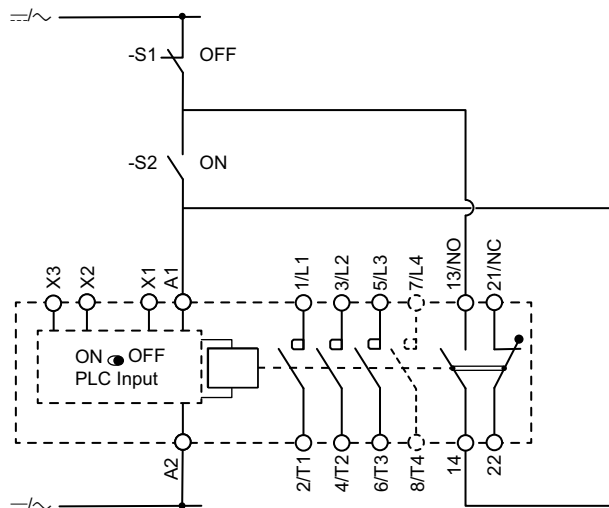

**With PLC input switch in the position ON**

A1-A2 control module terminals are used to supply the electronics and the coil of the control module.

X1-X2-X3 control module terminals are used to close and open the contactor through 24 Vdc control orders.

The poles are closed as soon as the control voltage is supplied to A1-A2 control module terminals and the command on X1 and X3 terminals is ON.

The poles are open as soon as the command on X1 and X3 terminals is OFF or if the control voltage is removed from A1-A2 control module terminals.

Depending on the control circuit wiring diagram, the control mode can be two-wire mode or three-wire mode (see Standard contactor for detail).

**Two-wire mode: maintained command**

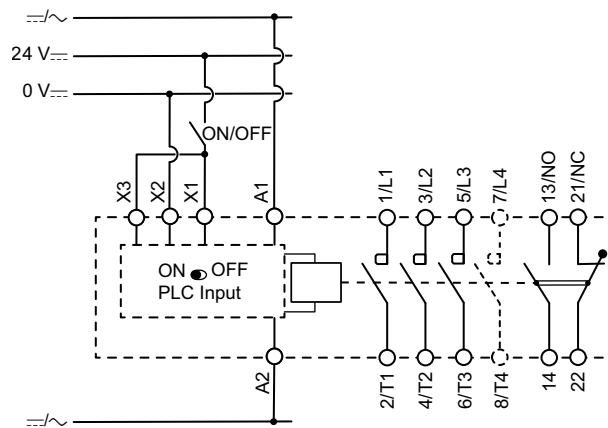

**Three-wire mode: pulse command**

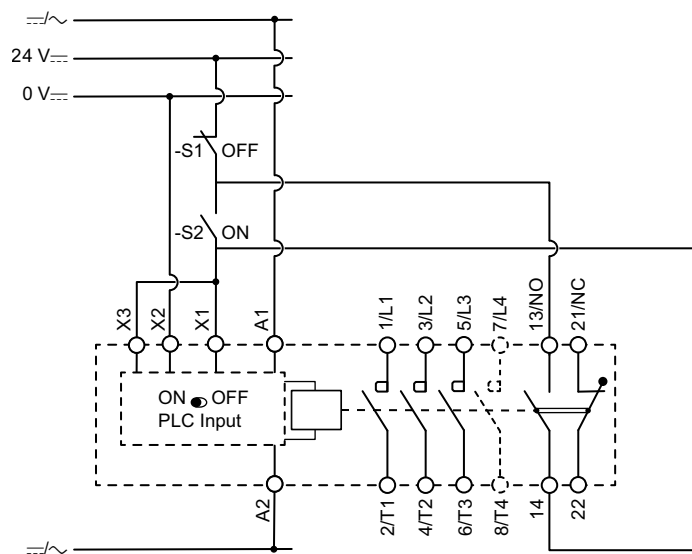

## Standard and DC Contactor without PLC Inputs

Coil voltage supply and control signal are the same signal and use just one channel connected to A1-A2 control module terminals.

The poles are closed as soon as the control voltage is supplied to A1-A2 control module terminals.

The poles are open as soon as the control voltage is removed from A1-A2 control module terminals.

Depending on the control circuit wiring diagram, the control mode has two types:

- Maintained type (two-wire mode)
- Pulse type (three-wire mode)

**Two-wire mode:** The command is maintained type. The poles close and stay closed as soon as the command is ON.

The poles open and stay opened as soon as the command is OFF.

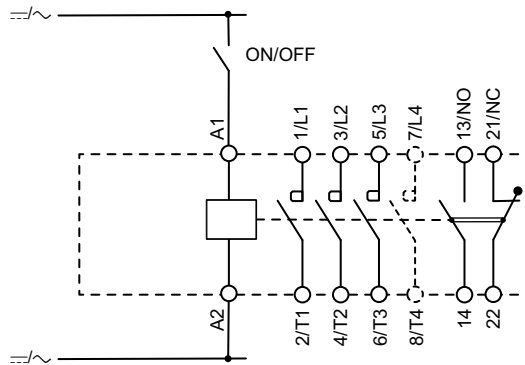

**Three-wire mode:** The commands are pulse type. The use of one NO auxiliary contact and two command components are necessary.

The poles close as soon as there is a pulse command ON. The poles stay closed up to a pulse command OFF.

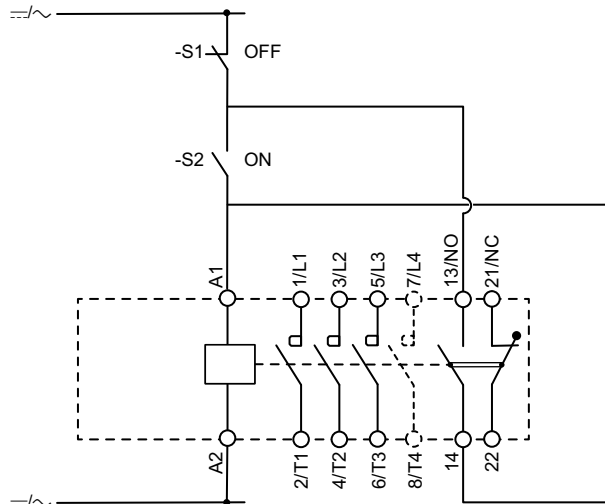

# TeSys Protect-Giga Electronic Overload Relays

## Overview

TeSys Protect-Giga electronic overload relays are self-powered electronic thermal overload relays with thermal memory. They are designed to protect 50/60 Hz three-phase or single-phase asynchronous motors.

The TeSys Giga overload relays can be mounted directly on TeSys Giga contactors of the same size, or mounted standalone.

The overload relays provide the below current-based protection functions:

- Thermal overload protection
- Ground-fault protection
- Phase imbalance protection
- Phase loss protection

The overload relays are not compatible for the DC motor protection.

## Range

The table below describes the range of the TeSys Giga electronic overload relays:

Commercial reference	Ir/FLA setting range	Direct mounting on contactor
LR9G115	28–115 A	LC1G115–225
LR9G225	57–225 A	LC1G115–225
LR9G500	125–500 A	LC1G265–500
LR9G630	160–630 A	LC1G630–800

## Coding Principle

The commercial reference of TeSys Giga overload relays is coded with significant features to explain the type and the ratings of the overload relay.

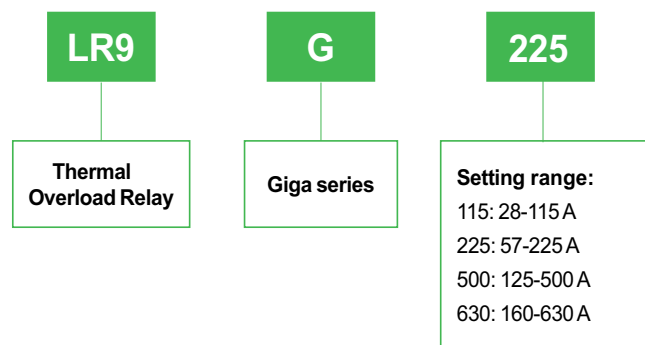

## Hardware Description

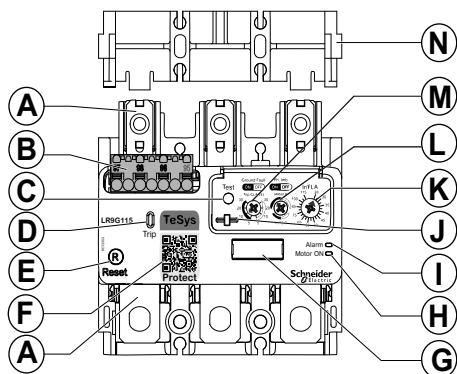

Label	Description
A	Power connections
B	Control terminal
C	Test button
D	Trip indicator
E	Reset button
F	QR code
G	Clip-on marker holder
H	Motor ON green LED
I	Alarm orange LED
J	Sealable cover
K	Ir/FLA setting
L	Overload reset mode setting and phase imbalance activation
M	Trip class setting and ground fault activation
N	Phase separator adaptor

## Motor ON and Alarm LEDs

LED	LED status	Indication
Motor ON	Green steady	The motor is supplied: <ul style="list-style-type: none"> <li>On LR9G115 or LR9G225 relays: the current measured is higher than 25 A</li> <li>On LR9G500 or LR9G630 relays: the current measured is higher than 50 A</li> </ul>
	Green blinking	An overload relay internal malfunction is detected, see <a href="#">Troubleshooting</a> , page 208
	OFF	The motor is not supplied: <ul style="list-style-type: none"> <li>On LR9G115 or LR9G225 relays: the current measured is lower than 25 A</li> <li>On LR9G500 or LR9G630 relays: the current measured is lower than 50 A</li> </ul>
Alarm	Orange steady	Overload alarm: 90% of the motor thermal capacity is reached

## Ir/FLA Setting

The Ir/FLA setting corresponds to the rated current of the motor or full load amp and can be adjusted with a 56-position rotary switch.

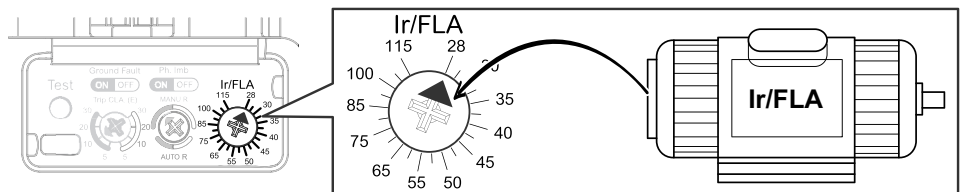



## Overload Reset Mode Setting and Phase Imbalance Activation

The same rotary switch is used:

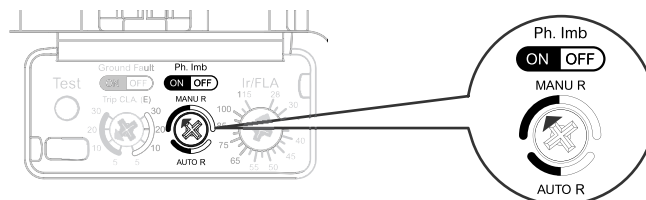
- to enable or disable the automatic reset of the thermal overload protection.
- to enable or disable the phase imbalance protection.



<p>Ph. Imb</p> <p><b>ON</b> OFF</p> <p>MANU R</p> <p>AUTO R</p>	The thermal overload protection automatic reset is disabled and the phase imbalance protection is enabled.
<p>Ph. Imb</p> <p><b>ON</b> OFF</p> <p>MANU R</p> <p>AUTO R</p>	The thermal overload protection automatic reset is disabled and the phase imbalance protection is disabled.

<p>Ph. Imb  <input checked="" type="checkbox"/> ON <input type="checkbox"/> OFF                  MANU R                    AUTO R</p>	<p>The thermal overload protection automatic reset is enabled and the phase imbalance protection is enabled.</p>
<p>Ph. Imb  <input checked="" type="checkbox"/> ON <input type="checkbox"/> OFF                  MANU R                    AUTO R</p>	<p>The thermal overload protection automatic reset is enabled and the phase imbalance protection is disabled.</p>

## Trip Class Setting and Ground Fault Activation

The same rotary switch is used:

- to set the trip class of the thermal overload protection.
- to enable or disable the ground fault protection.

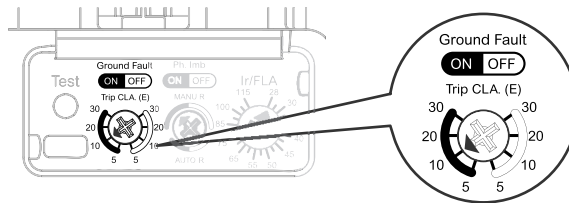

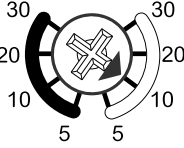
<p>Ground Fault  <input checked="" type="checkbox"/> ON <input type="checkbox"/> OFF                  Trip CLA. (E)  </p>	<p>The ground fault protection is enabled and the thermal overload trip class is set to 10E.</p>
<p>Ground Fault  <input type="checkbox"/> ON <input checked="" type="checkbox"/> OFF                  Trip CLA. (E)  </p>	<p>The ground fault protection is disabled and the thermal overload trip class is set to 10E.</p>

## QR Code

When the QR code on the front face of a TeSys Giga series device is scanned with a smartphone having a QR code reader and connected to the internet, Go2SE Landing Page, page 41 is displayed. The landing page displays some information about the device and a list of menus.

## Wiring Diagram

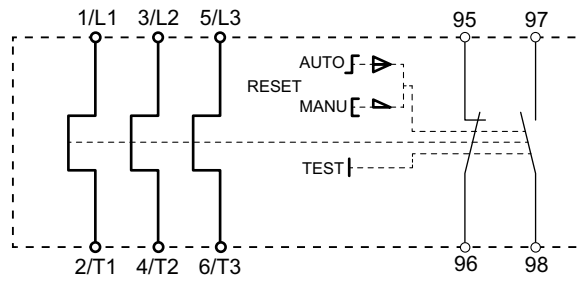

## Current-Based Protection Functions

There are four current-based protection functions provided by the overload relay:

- Thermal overload protection
- Phase loss protection
- Phase imbalance protection
- Ground-fault protection

## Operation

The state of the auxiliary contacts of the overload relay changes, when a protection function triggers a tripping:

- NC 95/96 contact state changes from closed to open.
- NO 97/98 contact state changes from open to closed.

The trip state is latched and is indicated by the trip indicator on the front face of the overload relay. A reset action is required to acknowledge the trip condition and to release the auxiliary contacts.

The auxiliary contacts of the overload relay can be used as follows:

- the NC contact can be used to switch off the contactor and then stop the motor.
- the NO contact can be used to signal remotely the state of the overload relay.

## Trip Reset

The trip state of the overload relay is latched and must be reset. The reset action releases the trip indicator and the auxiliary contacts:

- NC 95/96 contact changes from open to closed.
- NO 97/98 contact changes from closed to open.

Once tripped, the overload relay can always be reset manually. Only trip due to thermal overload protection can be reset automatically. For more information, refer to Thermal Overload Protection, page 34.

To reset the overload relay manually:

- Push the reset button mechanically on the overload relay :
  - On the front face or
  - Using the flexible cable LAD7305
- Or send an electrical remote reset order by using the electrical remote reset accessory LAD703●.

**NOTE:** A trip order always takes priority over a reset action.

## Factory Settings

The overload relays are delivered with the factory settings as follows:

- Thermal overload protection: enabled.
- Ir/FLA threshold: Ir/FLA minimum value.
- Reset mode: Manual.
- Trip class: 10E.
- Phase loss protection: enabled.
- Phase imbalance protection: enabled.
- Ground-fault protection: enabled.

## Thermal Overload Protection

### Overview

The thermal overload protection is used to protect asynchronous motors against thermal overload conforming to the IEC 60947-4-1 and UL 60947-4-1 standards.

The thermal overload protection can be used to protect:

- Three-phase IE1, IE2, IE3, and IE4 asynchronous motors.
- Single-phase asynchronous motors.

The thermal overload condition causes the overheating of the motor. Thermal overload conditions occur:

- During the starting phase when the starting time is too long, or if there is stalling conditions.
- During operation if there is jam condition or any condition that results to increase abnormally the currents flowing in the motor.

For more information on protection of single-phase motors, see [Single-Phase Motor Application](#), page 161.

### Operation

The overload relay calculates the thermal state and thermal capacity of the motor continuously.

- When the motor thermal capacity used exceeds 90%: the Alarm LED on the overload relay turns on steady orange to signal an alarm, indicating that the motor is approaching a thermal overload. The motor will stop shortly, if no action is performed to solve the thermal overload. The thermal overload alarm is cleared by the overload relay when the thermal capacity used falls below 80%.
- When the motor thermal capacity used exceeds 100%: the thermal overload protection triggers a trip and the state of the auxiliary contacts changes.

**NOTE:** The thermal overload protection cannot be disabled.

## Settings

The settings of the thermal overload protection are Ir/FLA threshold and trip class.

- **Ir/FLA threshold**

The Ir/FLA threshold corresponds to the rated current of the motor or full load amp and can be adjusted with a 56-position rotary switch.

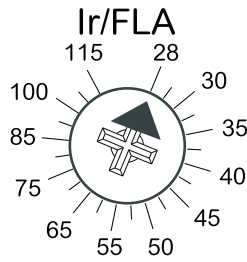

The table below provides the setting range of the Ir/FLA threshold:

Commercial reference	Ir/FLA setting range
LR9G115	28–115 A
LR9G225	57–225 A
LR9G500	125–500 A
LR9G630	160–630 A

- **Trip class**

The trip class allows to adapt the tripping time of the thermal overload protection to the application. Trip classes are defined by the IEC 60947-4-1 and UL 60947-4-1 standards. The trip class can be selected with a rotary switch.

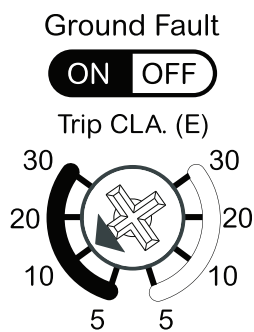

The following table indicates the tripping time ( $T_p$ ) depending on the trip class selected:

Current in the load	Class 5E	Class 10E	Class 20E	Class 30E
$7.2 \times I_r$	$3 \text{ s} < T_p \leq 5 \text{ s}$	$5 \text{ s} < T_p \leq 10 \text{ s}$	$10 \text{ s} < T_p \leq 20 \text{ s}$	$20 \text{ s} < T_p \leq 30 \text{ s}$

## Tripping Curves

The tripping curves of the thermal overload protection indicates the tripping time ( $T_p$ ) for each trip class depending on the current load and the thermal state of the overload relay. The two states are the cold state and the hot state:

- **Cold state:** Thermal state of the overload relay when it was not loaded previously and the thermal capacity used is 0%.
- **Hot state:** Thermal state of the overload relay when it was loaded at setting current and the thermal capacity used is 75%.

**Class 5E**

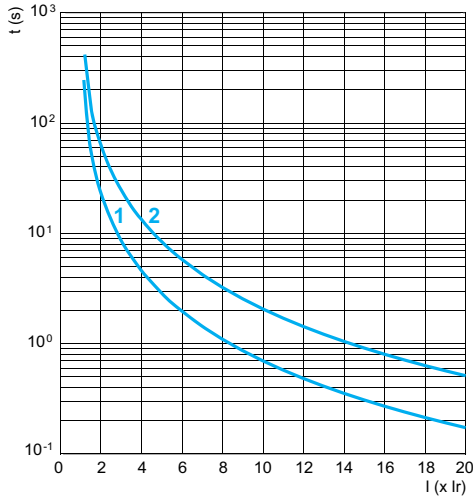

1 Hot State  
2 Cold State

**Class 10E**

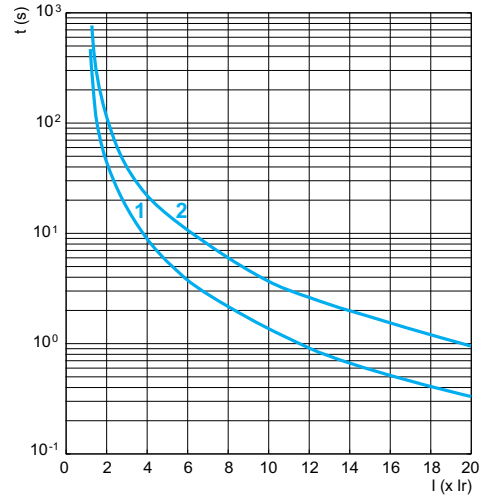

1 Hot State  
2 Cold State

**Class 20E**

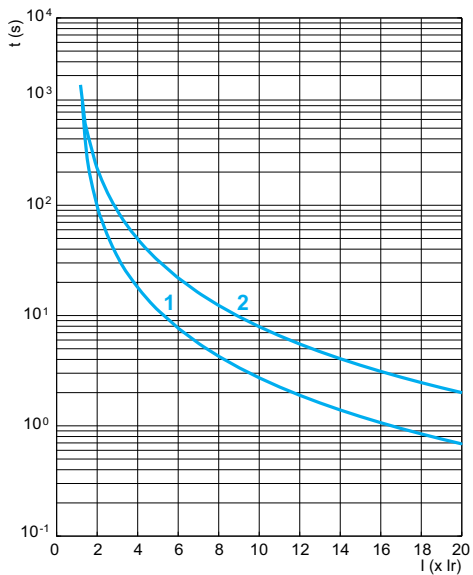

1 Hot State  
2 Cold State

**Class 30E**

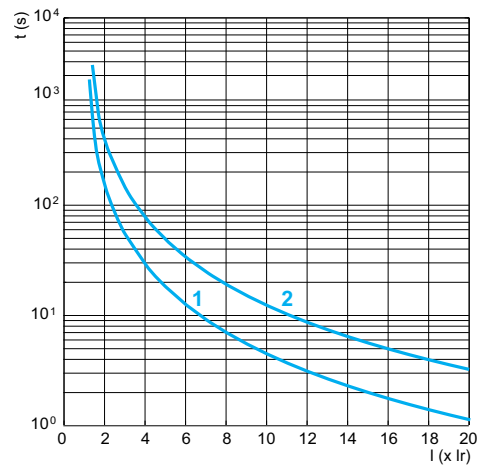

1 Hot State  
2 Cold State

## Manual Reset

The thermal overload protection can be reset manually. For more information, refer to Trip Reset, page 33.

## Automatic Reset

### ⚠ WARNING

#### UNINTENDED EQUIPMENT OPERATION

Before setting to **AUTO R**, ensure that automatic restart of the motor will not result in unsafe conditions.

**Failure to follow these instructions can result in death, serious injury, or equipment damage.**

The automatic reset of the thermal overload protection can be enabled or disabled by using a rotary switch.

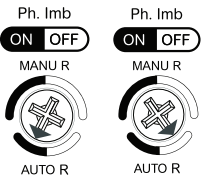
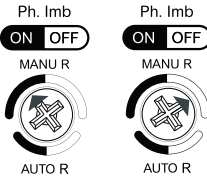
	<p>The thermal overload protection automatic reset is enabled.</p>
	<p>The thermal overload protection automatic reset is disabled.</p>

When the automatic reset is enabled, the thermal overload trip is reset automatically in  $2\pm 1$  minutes.

## Phase Loss Protection

### Overview

The phase loss protection is used to protect three-phase asynchronous motors against phase loss conforming to the IEC 60947-4-1 and UL 60947-4-1 standards.

The phase loss protection can be used to protect three-phase IE1, IE2, IE3, and IE4 asynchronous motors.

Phase loss causes the overheating of the motor. It occurs in case of blown fuses or loose power connection.

### Operation

The overload relay calculates the rms current value in each phase continuously. When the rms current value in one of the three phases is lower than  $0.1 I_r$  and the rms current value in another phase is greater than  $0.8 I_r$ , the overload relay triggers a tripping in  $4 \pm 1$  s.

**NOTE:** The phase loss protection cannot be disabled.

### Manual Reset

The phase loss protection can be reset manually only. For more information, refer to Trip Reset, page 33.

# Phase Imbalance Protection

## Overview

The phase imbalance protection is used to protect asynchronous motors against current phase imbalance conforming to the IEC 60947-4-1 and UL 60947-4-1 standards.

The phase imbalance protection can be used to protect three-phase IE1, IE2, IE3, and IE4 asynchronous motors.

Phase imbalance causes the overheating of the motor. It can occur in case of:

- Long main supply lines.
- Defective contact on the incomer switch.
- Imbalanced network.

## Operation

The overload relay calculates the imbalance current ratio in each phase as given below:

- $li1 = (| I1 - I_{avg} | \times 100) / I_{avg}$
- $li2 = (| I2 - I_{avg} | \times 100) / I_{avg}$
- $li3 = (| I3 - I_{avg} | \times 100) / I_{avg}$

Where  $I_{avg} = (I1 + I2 + I3) / 3$ , and I1, I2, I3 are the current values in L1, L2, L3 phases.

The network imbalance ratio limb is the maximum imbalance current ratio calculated:  $limb = \text{Max} (li1, li2, li3)$ .

When the imbalance ratio limb exceeds 40%, the overload relay triggers a trip in 5 +/- 1 s.

## Settings

The table below indicates the position of the rotary switch used to enable or disable the phase imbalance protection.

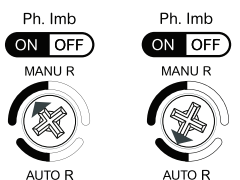
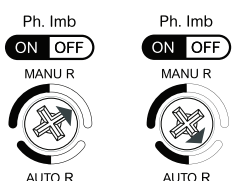
	<p>The phase imbalance protection is enabled.</p>
	<p>The phase imbalance protection is disabled.</p>

## Manual Reset

The phase imbalance protection can be reset manually only. For more information, refer to Trip Reset, page 33.

# Ground Fault Protection

## Overview

The ground-fault protection is used to protect asynchronous motors against ground fault conforming to the IEC 60947-4-1 and UL 60947-4-1 standards.

The protection type is Class A according to UL 60947-4-1 standard.

The ground-fault protection can be used to protect three-phase IE1, IE2, IE3, and IE4 asynchronous motors.

Ground fault occurs when the insulation drops on the load circuit due to vibration or moisture.

## Settings

The table below shows the position of the rotary switch used to enable or disable the ground-fault protection.

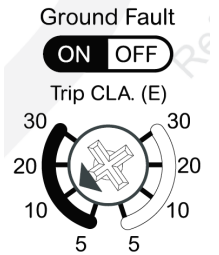
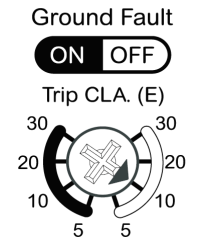
 <p>Ground Fault <b>ON</b> OFF</p> <p>Trip CLA. (E)</p> <p>30 30 20 20 10 10 5 5</p>	<p>The ground fault protection is enabled. <math>I_g = 0.75 I_r</math>.</p>
 <p>Ground Fault <b>ON</b> OFF</p> <p>Trip CLA. (E)</p> <p>30 30 20 20 10 10 5 5</p>	<p>The ground fault protection is disabled.</p>

## Operation

The overload relay calculates the ground current  $I_g$  continuously. When the ground current  $I_g$  exceeds more than 10%, the relay trips in  $1 \pm 20\%$  s.

## Manual Reset

The ground fault protection can be reset manually only. For more information, refer to Trip Reset, page 33.

# Go2SE Landing Page

## Presentation

When the QR code on the front face of a TeSys Giga series device is scanned with a smartphone having a QR code reader and connected to the internet, the Go2SE landing page is displayed.

The landing page displays information about the device and a list of menus.

## Landing Page Description

The landing page is accessible from Android and iOS smartphones. It displays the same list of menus with slight differences in presentation.

The following example shows the landing page displayed on an android smartphone:

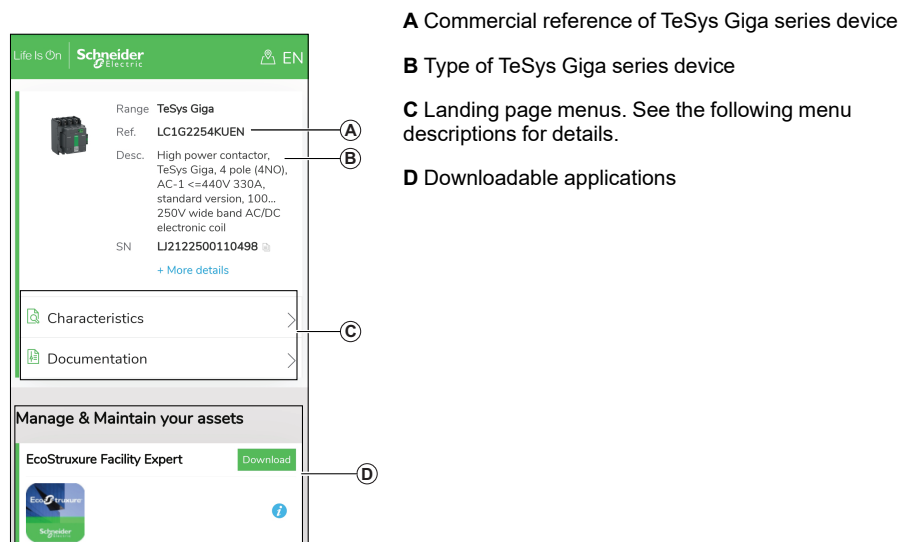

## Characteristics

Selecting this menu gives access to the product datasheet with detailed information about the TeSys Giga series device.

## Documentation

Selecting this menu gives access to the technical documentation related to the product.

## EcoStruxure Facility Expert App

Selecting this application gives access to the EcoStruxure Facility Expert mobile application that can be downloaded on Android and iOS smartphones. For smartphone compatibility, check on your application store.

EcoStruxure Facility Expert mobile application optimizes operations and maintenance, helping to ensure business continuity, and provides insights to service providers or facility managers.

EcoStruxure Facility Expert is a real-time collaborative technology available on mobile devices and PCs that enables managers and maintenance personnel to be connected with facilities and equipment. Information exchange between users is simple and fast.

The QR code on TeSys Giga series device enables managers and maintenance personnel to access the following automatic downloads:

- TeSys Giga series device identifier.
- Technical documentation.
- The maintenance plan for the TeSys Giga series device.

EcoStruxure Facility Expert enables managers and maintenance personnel to access the maintenance plan for TeSys Giga series devices.

EcoStruxure Facility Expert helps maintenance personnel to diagnose issues remotely and manage maintenance efficiently by:

- Providing relevant information on critical assets.
- Sending immediate state of the equipment and detailed information helping for diagnostics.

## mySchneider App

Selecting this application gives access to the Schneider Electric customer care mobile application **mySchneider** app that can be downloaded on Android and iOS smartphones. For smartphone compatibility, check on your application store. The customer care application offers self-service instructions and easy access to expert support and information.

## Schneider Electric Anti-Fake Query

Perform the following procedure to check anti-fake code:

1. Scan the QR code.

The following landing page of the contactor is displayed with the following information.

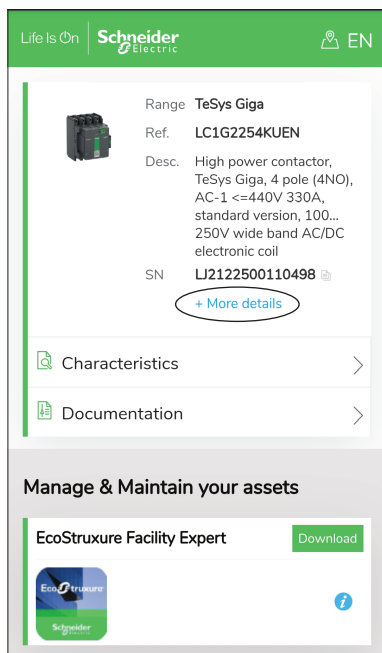

2. Click **More details**.

The following page is displayed.

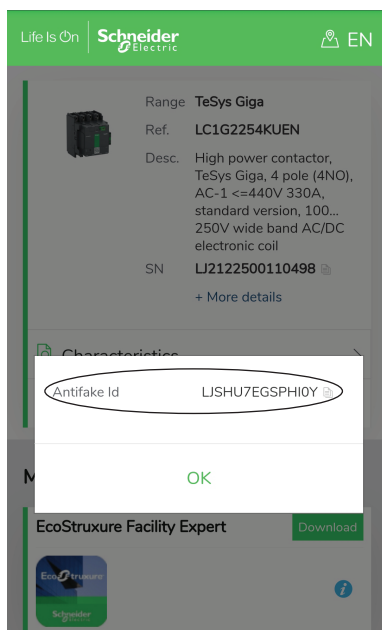

3. Click copy icon to copy the anti-fake code and click **OK** to return to the previous page.

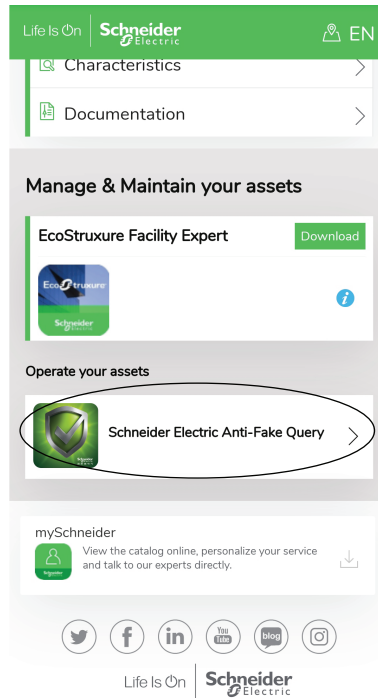

4. Click **Schneider Electric Anti-Fake Query**.  
The following page is displayed.

A screenshot of the 'Schneider Electric Anti-fake' query form. The form is displayed on a white background with a green header. It contains four input fields, each with an asterisk indicating it is required: 'Anti-fake code' with the value 'LJSHU7EGSPHI0Y', 'Customer name' with the placeholder 'Please input your name', 'Mobile NO.' with the placeholder 'Please input your Mobile NO.', and 'Verification code' with the value '7049'. Below the input fields is a prominent green button labeled 'Check Now'.

5. Paste the anti-fake code in the **Anti-fake code** field.
6. Enter your Customer Name and Mobile Number.
7. Type the displayed verification code in the **Verification code** field.
8. Click **Check Now**.

The following page is displayed if the device is a genuine TeSys Giga device.

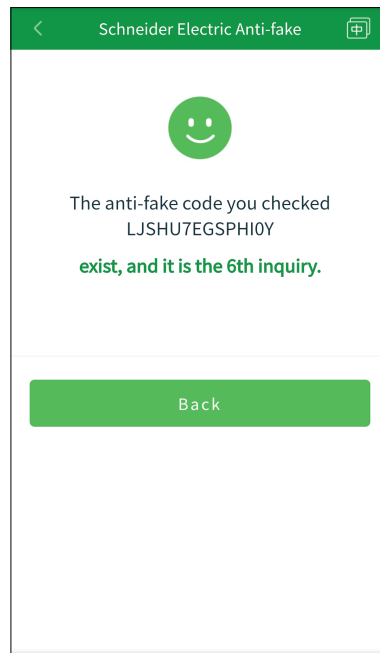

# Technical Characteristics

## What's in This Chapter

Dimensions.....	47
Weights .....	53
Thermal Dissipation.....	54
Contactors Technical Characteristics .....	55
Overload Relays Technical Characteristics .....	65
Contactors Accessory Technical Characteristics .....	67
Electromagnetic Compatibility .....	68
Short-Circuit Current Ratings (SCCR).....	69

# Dimensions

This section describes the dimensions of the TeSys Control-Giga contactors and TeSys Protect-Giga electronic overload relays. The dimensions are provided in millimeters and inches.

## 3-Pole Advanced Contactors

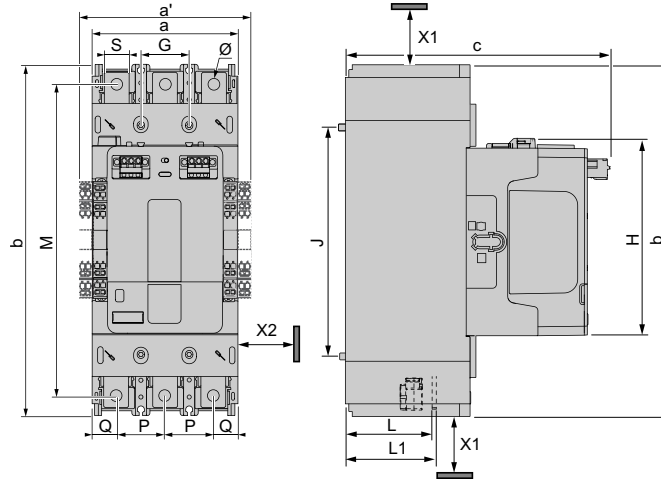

Labels	LC1G115–225	LC1G265–500	LC1G630–800
a	108 mm (4.25 in.)	140 mm (5.51 in.)	211 mm (8.31 in.)
a'	128 mm (5.03 in.)	160 mm (6.29 in.)	211 mm (8.31 in.)
b	255 mm (10.03 in.)	290 mm (11.41 in.)	388.5 mm (15.29 in.)
c	193 mm (7.59 in.)	226 mm (8.90 in.)	266 mm (10.47 in.)
G	35 mm (1.37 in.)	45 mm (1.77 in.)	70 mm (2.75 in.)
J	166 mm (6.53 in.)	187 mm (7.36 in.)	242 mm (9.52 in.)
M	226 mm (8.89 in.)	262 mm (10.31 in.)	349 mm (13.74 in.)
H	145 mm (5.70 in.)	167 mm (6.57 in.)	192 mm (7.56 in.)
L	64 mm (2.52 in.)	73 mm (2.87 in.)	99 mm ( 3.90 in. )
L1	67 mm (2.65 in.)	79 mm (3.11 in.)	107 mm (4.21 in.)
P	35 mm (1.37 in.)	45 mm (1.77 in.)	70 mm (2.75 in.)
Q	19 mm (0.74 in.)	25 mm (0.98 in.)	35.3 mm (1.38 in.)
S	18 mm (0.70 in.)	30 mm (1.18 in.)	48 mm (1.88 in.)
Ø	8.5 mm (0.33 in.)	10.6 mm (0.41 in.)	13 mm (0.51 in.)

**NOTE:** a' is the dimension with 2 auxiliary contact modules on both sides. a' = a for LC1G630–800.

## Clearance Distances

Labels	Definition	Value
X1	Arc flash clearance distance up to 1000 V operating voltage.	40 mm (1.60 in.)
X2	Minimum electrical clearance according to operating voltage inside metallic cabinets and for adjacent installation of contactors.	5 mm (0.19 in.)

## 4-Pole Advanced Contactors

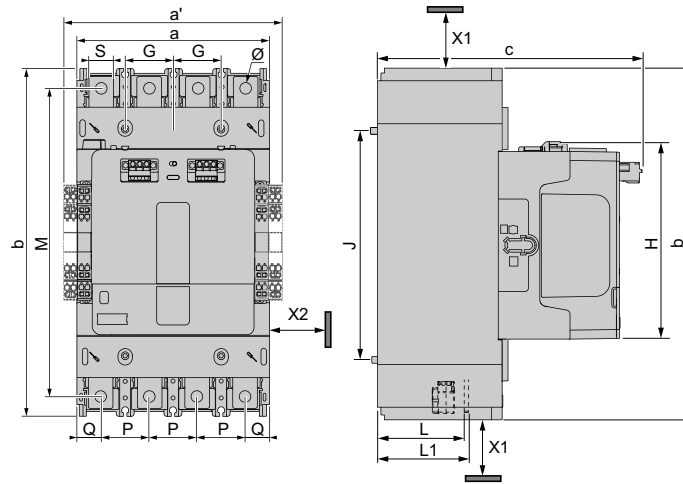

Labels	LC1G1154–2254	LC1G2654–5004	LC1G6304–8004
a	143 mm (5.62 in.)	185 mm (7.28 in.)	281 mm (11.06 in.)
a'	163 mm (6.41 in.)	205 mm (8.07 in.)	281 mm (11.06 in.)
b	255 mm (10.03 in.)	290 mm (11.41 in.)	388.5 mm (15.29 in.)
c	193 mm (7.59 in.)	226 mm (8.90 in.)	266 mm (10.47 in.)
G	35 mm (1.37 in.)	45 mm (1.77 in.)	70 mm (2.75 in.)
J	166 mm (6.53 in.)	187 mm (7.36 in.)	242 mm (9.52 in.)
M	226 mm (8.89 in.)	262 mm (10.31 in.)	349 mm (13.74 in.)
H	145 mm (5.70 in.)	167 mm (6.57 in.)	192 mm (7.55 in.)
L	64 mm (2.52 in.)	73 mm (2.87 in.)	99 mm ( 3.90 in. )
L1	67 mm (2.65 in.)	79 mm (3.11 in.)	107 mm (4.21 in.)
P	35 mm (1.37 in.)	45 mm (1.77 in.)	70 mm (2.75 in.)
Q	19 mm (0.74 in.)	25 mm (0.98 in.)	35.3 mm (1.38 in.)
S	18 mm (0.70 in.)	30 mm (1.18 in.)	48 mm (1.88 in.)
Ø	8.5 mm (0.33 in.)	10.6 mm (0.41 in.)	13 mm (0.51 in.)

**NOTE:** a' is the dimension with 2 auxiliary contact modules on both sides. a' = a for LC1G630–800.

## Clearance Distances

Labels	Definition	Value
X1	Arc flash clearance distance up to 1000 V operating voltage.	40 mm (1.60 in.)
X2	Minimum electrical clearance according to operating voltage inside metallic cabinets and for adjacent installation of contactors.	5 mm (0.19 in.)

### 3-Pole Standard Contactors

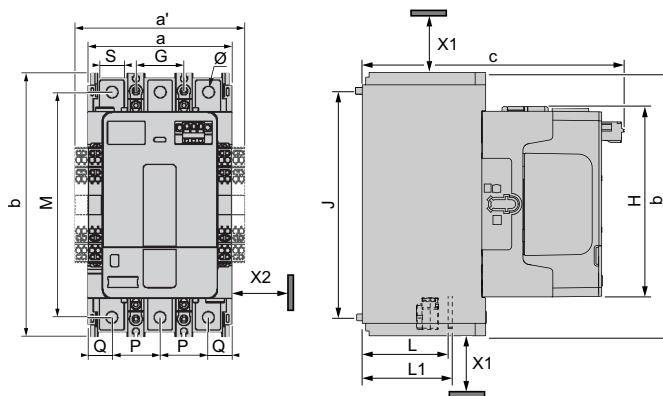

Labels	LC1G115–225	LC1G265–500	LC1G630–800
a	108 mm (4.25 in.)	140 mm (5.51 in.)	210 mm (8.26 in.)
a'	128 mm (5.03 in.)	160 mm (6.29 in.)	210 mm (8.26 in.)
b	193 mm (7.60 in.)	225 mm (8.85 in.)	284 mm (12.75 in.)
c	193 mm (7.59 in.)	226 mm (8.90 in.)	266 mm (10.47 in.)
G	35 mm (1.37 in.)	45 mm (1.77 in.)	70 mm (2.75 in.)
J	166 mm (6.53 in.)	187 mm (7.36 in.)	242 mm (9.52 in.)
M	164 mm (6.45 in.)	197 mm (7.75 in.)	244 mm (9.60 in.)
H	139 mm (5.47 in.)	162 mm (6.38 in.)	187 mm (7.36 in.)
L	67 mm (2.65 in.)	79 mm (3.11 in.)	107 mm (4.21 in.)
L1	70 mm (2.75 in.)	82 mm (3.22 in.)	113 mm (4.45 in.)
P	35 mm (1.37 in.)	45 mm (1.77 in.)	70 mm (2.75 in.)
Q	19 mm (0.74 in.)	25 mm (0.98 in.)	35.3 mm (1.38 in.)
S	18 mm (0.70 in.)	30 mm (1.18 in.)	48 mm (1.88 in.)
Ø	8.5 mm (0.33 in.)	10.6 mm (0.41 in.)	13 mm (0.51 in.)

**NOTE:** a' is the dimension with 2 auxiliary contact modules on both sides. a' = a for LC1G630–800.

### Clearance Distances

Labels	Definition	Value
X1	Arc flash clearance distance up to 1000 V operating voltage.	40 mm (1.60 in.)
X2	Minimum electrical clearance according to operating voltage inside metallic cabinets and for adjacent installation of contactors.	5 mm (0.19 in.)

## 4-Pole Standard Contactors

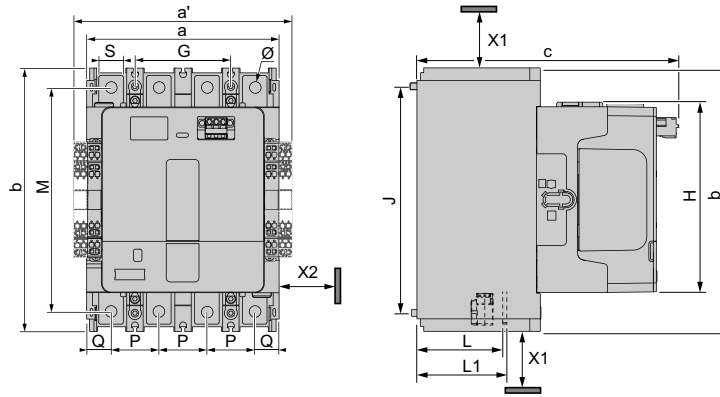

Labels	LC1G1154–2254	LC1G2654–5004	LC1G6304–8004
a	143 mm (5.62 in.)	185 mm (7.28 in.)	281 mm (11.06 in.)
a'	163 mm (6.41 in.)	205 mm (8.07 in.)	281 mm (11.06 in.)
b	193 mm (7.60 in.)	225 mm (8.85 in.)	284 mm (12.75 in.)
c	193 mm (7.59 in.)	226 mm (8.90 in.)	266 mm (10.47 in.)
G	35 mm (1.37 in.)	45 mm (1.77 in.)	70 mm (2.75 in.)
J	166 mm (6.53 in.)	187 mm (7.36 in.)	242 mm (9.52 in.)
M	164 mm (6.45 in.)	197 mm (7.75 in.)	244 mm (9.60 in.)
H	139 mm (5.47 in.)	162 mm (6.38 in.)	187 mm (7.36 in.)
L	67 mm (2.65 in.)	79 mm (3.11 in.)	107 mm (4.21 in.)
L1	70 mm (2.75 in.)	82 mm (3.22 in.)	113 mm (4.45 in.)
P	35 mm (1.37 in.)	45 mm (1.77 in.)	70 mm (2.75 in.)
Q	19 mm (0.74 in.)	25 mm (0.98 in.)	35.3 mm (1.38 in.)
S	18 mm (0.70 in.)	30 mm (1.18 in.)	48 mm (1.88 in.)
Ø	8.5 mm (0.33 in.)	10.6 mm (0.41 in.)	13 mm (0.51 in.)

**NOTE:** a' is the dimension with 2 auxiliary contact modules on both sides. a' = a for LC1G630–800.

## Clearance Distances

Labels	Definition	Value
X1	Arc flash clearance distance up to 1000 V operating voltage.	40 mm (1.60 in.)
X2	Minimum electrical clearance according to operating voltage inside metallic cabinets and for adjacent installation of contactors.	5 mm (0.19 in.)

### 3-Pole DC Contactors

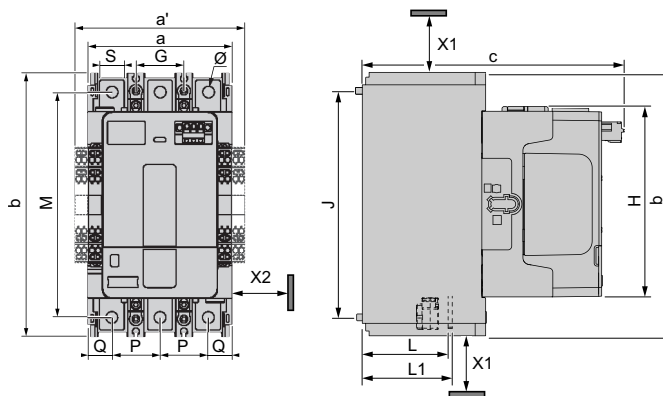

Labels	LC1G250DC
a	108 mm (4.25 in.)
a'	128 mm (5.03 in.)
b	193 mm (7.60 in.)
c	193 mm (7.59 in.)
G	35 mm (1.37 in.)
J	166 mm (6.53 in.)
M	164 mm (6.45 in.)
H	139 mm (5.47 in.)
L	67 mm (2.65 in.)
L1	70 mm (2.75 in.)
P	35 mm (1.37 in.)
Q	19 mm (0.74 in.)
S	18 mm (0.70 in.)
Ø	8.5 mm (0.33 in.)

**NOTE:** a' is the dimension with 2 auxiliary contact modules on both sides.

### Clearance Distances

Labels	Definition	Value
X1	Arc flash clearance distance up to 1000 V operating voltage.	40 mm (1.60 in.)
X2	Minimum electrical clearance according to operating voltage inside metallic cabinets and for adjacent installation of contactors.	5 mm (0.19 in.)

## Overload Relays

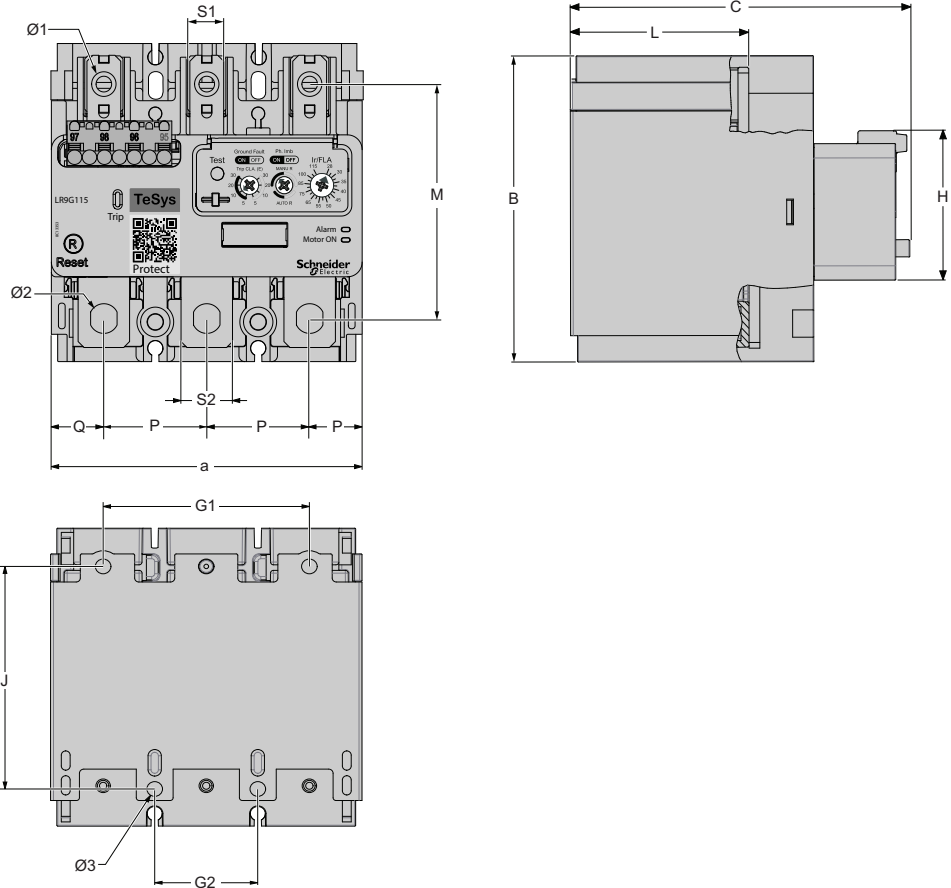

Labels	LR9G115–LR9G225	LR9G500	LR9G630
a	106 mm (4.17 in.)	140 mm (5.51 in.)	210 mm (8.29 in.)
b	109 mm (4.29 in.)	116 mm (4.56 in.)	149 mm (5.83 in.)
c	126 mm (4.96 in.)	139 mm (5.48 in.)	186 mm (7.32 in.)
G1	70 mm (2.75 in.)	119 mm (4.69 in.)	186 mm (7.32 in.)
G2	35 mm (1.37 in.)	45 mm (1.77 in.)	70 mm (2.75 in.)
J	80 mm (3.15 in.)	68 mm (2.67 in.)	86 mm (3.38 in.)
M	78 mm (3.1 in.)	83 mm (3.28 in.)	100 mm (3.93 in.)
H	52 mm (2.06 in.)	47 mm (1.88 in.)	47 mm (1.88 in.)
L	66 mm (2.61 in.)	79 mm (3.11 in.)	107 mm (4.21 in.)
P	35 mm (1.37 in.)	45 mm (1.77 in.)	70 mm (2.75 in.)
Q	18 mm (0.7 in.)	25 mm (0.98 in.)	35 mm (1.37 in.)
S1	11.5 mm (0.45 in.)	22.5 mm (0.88 in.)	22.5 mm (0.88 in.)
S2	17.5 mm (0.68 in.)	30.5 mm (1.20 in.)	50 mm (1.96 in.)
Ø1	8.3 mm (0.32 in.)	10.6 mm (0.41 in.)	13 mm (0.51 in.)
Ø2	9 mm (0.35 in.)	10.6 mm (0.41 in.)	13 mm (0.51 in.)
Ø3	5.3 mm (0.19 in.)	5.3 mm (0.19 in.)	8.5 mm (0.33 in.)

## Weights

This section describes the weights for the TeSys Control-Giga contactors and TeSys Protect-Giga electronic overload relays.

Device	Number of poles	Commercial references	Weight
Advanced contactor	3P	LC1G115-225	5.3 kg (11.68 lb)
		LC1G265-500	9.1 kg (20.06 lb)
		LC1G630-800	19.2 kg (42.33 lb)
	4P	LC1G1154-2254	6.4 kg (14.11 lb)
		LC1G2654-5004	11.3 kg (24.91 lb)
		LC1G630-800	24.2 kg (53.35 lb)
Standard contactor	3P	LC1G115-225	4.8 kg (10.58 lb)
		LC1G265-500	8 kg (17.64 lb)
		LC1G630-800	16.4 kg (36.16 lb)
	4P	LC1G1154-2254	5.8 kg (12.79 lb)
		LC1G2654-5004	9.7 kg (21.38 lb)
		LC1G630-800	21 kg (46.3 lb)
DC contactor	3P	LC1G250DC	4.8 kg (10.58 lb)
Overload relay	3P	LR9G115-225	1.4 kg (3.09 lb)
		LR9G500	2.1 kg (4.63 lb)
		LR9G630	3.4 kg (7.5 lb)

## Thermal Dissipation

This section describes the thermal dissipation characteristics for the contactors and control modules, and thermal overload relays.

### Main Power Lines of Contactors

Contactor	Power dissipation per pole at maximum current with AC-1 load	Power dissipation per pole at maximum current with AC-3/AC-3e load
LC1G115	9 W	2 W
LC1G150	11 W	3 W
LC1G185	14 W	5 W
LC1G225	16 W	8 W
LC1G265	40 W	19 W
LC1G330	52 W	29 W
LC1G400	61 W	32 W
LC1G500	98 W	50 W
LC1G630	88 W	32 W
LC1G800	88 W	51 W

### Contactors Control Modules

Contactor	Heat dissipation for standard control module	Heat dissipation for advanced control module
LC1G115-225	5-6 W	4-5 W
LC1G225-330	6-7 W	5-6 W
LC1G400-500	6-7 W	5-6 W
LC1G630-800	6-7 W	5-6 W

### Overload Relays

Overload relay	Maximum heat dissipation at I <sub>r</sub> Max
LR9G115	1 W
LR9G225	3 W
LR9G500	5 W
LR9G630	8 W

## Contactors Technical Characteristics

The contactors are electrically isolated between the internal electronic circuit and the input/output channels. These limits are described by the environmental characteristics, pole characteristics, and the control module characteristics given below. This equipment meets CE requirements as indicated in the tables.

### Environmental Characteristics

<b>▲ WARNING</b>
<b>UNINTENDED EQUIPMENT OPERATION</b>
Install and operate the contactors according to the conditions described in the environmental characteristics table.
<b>Failure to follow these instructions can result in death, serious injury, or equipment damage.</b>

### TeSys Giga – Contactors for General Applications

The environmental characteristics of the advanced and standard contactors for general applications are listed in the following table:

Environmental Characteristics	LC1G115–225	LC1G265–500	LC1G630–800
Number of poles	3 or 4	3 or 4	3 or 4
Rated insulation voltage (Ui)	1000 V		
Over-voltage category	III		
Degree of pollution	3		
Rated impulse withstand power circuit	8 kV		
Conforming to standards	<ul style="list-style-type: none"> <li>• IEC 60947–4–1</li> <li>• UL 60947–4–1</li> <li>• CAN/CSA-C22.2 No. 60947–4–1</li> <li>• JIS C 8201–4–1</li> <li>• GB/T 14048.4</li> <li>• IEC 60721–3–3 3C3</li> </ul>		
Product certifications	<ul style="list-style-type: none"> <li>• cULus , CCC, CB certification, CE Marking, UKCA Marking</li> <li>• EU-RO-MR, Marine Certification by DNV</li> </ul>		
Degree of protection (Conforming to IEC 60529 and VDE 0106)	IP 2X with TeSys Giga terminal shrouds.		
Climatic withstand	According to IACS E10		
Ambient air temperature around the Giga contactor	Storage	-60 to +80 °C (-76 to 176 °F)	
	Operation	-25 to +60 °C (-13 to 140 °F)	
	Permissible at Uc	-40 to +70 °C (-40 to 158 °F)	
Maximum operating altitude (Without derating)	3000 m (9850 ft)		
Shock resistance 1/2 sine wave = 11 ms (Conforming to IEC 60068-2-27)	contactor open	10 gn	
	contactor close	15 gn	
Vibration resistance 5–300 Hz (Conforming to IEC 60068-2-6)	contactor open	2 gn	
	contactor close	4 gn	

## TeSys Giga – Contactors for Railway Applications

The environmental characteristics of the advanced or standard contactors for railway applications are listed in the following table:

Environmental Characteristics	LC1G115– 225EHES207	LC1G265– 500EHES207	LC1G630– 800EHES207	LC1G630- 800LSES207N
	LC1G1154– 2254EHES207	LC1G2654– 5004EHES207	LC1G6304– 8004EHES207	
Number of poles	3 or 4	3 or 4	3 or 4	3
Rated insulation voltage (Ui)	1000 V			
Over-voltage category	III			
Degree of pollution	3			
Rated impulse withstand power circuit	8 kV			
Conforming to standards	<ul style="list-style-type: none"> <li>• IEC 60947–4–1</li> <li>• UL 60947–4–1</li> <li>• CAN/CSA-C22.2 No. 60947–4–1</li> <li>• JIS C 8201–4–1</li> <li>• EN 45545</li> <li>• IEC 61373</li> <li>• IEC 60077</li> <li>• EN 50155</li> <li>• TB/T 3526-2018</li> <li>• GB 21413-1/2</li> <li>• GB/T 25119</li> <li>• GB/T 21563-2018</li> <li>• GB/T 14048.4</li> </ul>			
Coil voltage	<ul style="list-style-type: none"> <li>• For EHE - 40–130V</li> <li>• For LSE - 200–500V</li> </ul>			
Product certifications	cULus , CCC, CB certification, CE Marking, UKCA Marking			
Degree of protection (Conforming to IEC 60529 and VDE 0106)	IP 2X with TeSys Giga terminal shrouds.			
Climatic withstand	According to IACS E10			
Ambient air temperature around the Giga contactor	Storage	-60 to +80 °C (-76 to 176 °F)		
	Operation	-25 to +60 °C (-13 to 140 °F)		
	Permissible at Uc	-40 to +70 °C (-40 to 158 °F)		
Maximum operating altitude (Without derating)	3000 m (9850 ft)			
Shock resistance 1/2 sine wave = 11 ms (Conforming to IEC 60068-2-27)	contactor open	10 gn		
	contactor close	15 gn		
Vibration resistance 5–300 Hz (Conforming to IEC 60068-2-6)	contactor open	2 gn		
	contactor close	4 gn		

## TeSys Giga – DC Contactors

<b>Environmental Characteristics</b>		<b>LC1G250DC</b>
Utilization category		DC-1
Number of poles		3
Rated insulation voltage (Ui)		1500 V
Over-voltage category		III
Degree of pollution		3
Rated impulse withstand power circuit		12 kV
Conforming to standards		<ul style="list-style-type: none"> <li>• IEC 60947-4-1</li> <li>• UL 60947-4-1</li> <li>• CAN/CSA-C22.2 No. 60947-4-1</li> <li>• GB/T 14048.4</li> <li>• IEC 60721-3-3 3C3</li> </ul>
Product certifications		cULus , CCC, CB certification, CE Marking, UKCA Marking
Ambient air temperature around the Giga contactor	Storage	-60 to +80 °C (-76 to 176 °F)
	Operation	-25 to +60 °C (-13 to 140 °F)
	Permissible at Uc	-40 to +70 °C (-40 to 158 °F)
Maximum operating altitude (Without derating)		3000 m (9850 ft)
Shock resistance 1/2 sine wave = 11 ms (Conforming to IEC 60068-2-27)	contactor open	10 gn
	contactor close	15 gn
Vibration resistance 5–300 Hz (Conforming to IEC 60068-2-6)	contactor open	2 gn
	contactor close	4 gn

## LC1G115–225 Pole Characteristics

Poles Characteristics		LC1G115	LC1G150	LC1G185	LC1G225
Number of poles		3 or 4	3 or 4	3 or 4	3 or 4
Rated operational current (I <sub>e</sub> ) (≤ 440 V)	In AC–3, ≤ 60 °C (140 °F)	115 A	150 A	185 A	225 A
	In AC–3e, ≤ 60 °C (140 °F)	115 A	145 A	177 A	209 A
	In AC–1, ≤ 40 °C (104 °F)	250 A	275 A	305 A	330 A
Rated operational voltage (U <sub>e</sub> )		Up to 1000 V <sup>(1)</sup>			
Rated frequency		50 – 60 Hz			
Frequency operating limits with derating		16 2/3 – 400 Hz Consult your technical support team for application with frequencies other than 50-60 Hz.			
Conventional thermal current (I <sub>th</sub> ) ≤ 40 °C (104 °F)		250 A	275 A	305 A	330 A
Rated making capacity	I rms conforming to IEC 60947–4–1	Making current: 10 x I in AC–3 or 12 x I in AC–4 Making current: 13 x I in AC-3e			
Rated breaking capacity	I rms conforming to IEC 60947–4–1	Making and breaking current: 8 x I in AC–3 or 10 x I in AC–4 Making and breaking current: 8.5 x I in AC-3e			
Maximum permissible current No current flowing for previous 60 minutes, at ≤ 40 °C (104 °F)	For 10 s	1100 A	1200 A	1500 A	1800 A
	For 30 s	640 A	700 A	920 A	1000 A
	For 1 min	520 A	600 A	740 A	850 A
	For 3 min	400 A	450 A	500 A	560 A
	For 10 min	320 A	350 A	400 A	440 A
Short-circuit protection by fuses	Fuses for motor application type aM- U <sub>e</sub> ≤ 440V	125 A	160 A	200 A	250 A
	Fuses for motor application type aM- U <sub>e</sub> ≤ 690V	125 A	160 A	160 A	200 A
	Fuses for general application: type gG- U <sub>e</sub> ≤ 690V	315 A	315 A	315 A	400 A
Average impedance per pole at I <sub>th</sub> and 50 Hz		0.15 mΩ			
<sup>(1)</sup> U <sub>e</sub> ≤ 1000 V for AC-1/ 690 V for AC-3/AC-3e/ AC-4 for LC1G115					

## LC1G265–500 Pole Characteristics

Poles Characteristics		LC1G265	LC1G330	LC1G400	LC1G500
Number of poles		3 or 4	3 or 4	3 or 4	3 or 4
Rated operational current (Ie) (≤ 440 V)	In AC–3, ≤ 60 °C (140 °F)	265 A	330 A	400 A	500 A
	In AC–3e, ≤ 60 °C (140 °F)	255 A	294 A	391 A	3P: 437 A 4P: 391 A
	In AC–1, ≤ 40 °C (104 °F)	385 A	440 A	550 A	700 A
Rated operational voltage (Ue)		Up to 1000 V			
Frequency operating limits with derating		16 2/3 – 400 Hz  Consult your technical support team for application with frequencies other than 50-60 Hz.			
Conventional thermal current (Ith) ≤ 40 °C (104 °F)		385 A	440 A	550 A	700 A
Rated making capacity	I rms conforming to IEC 60947–4–1	Making current: 10 x I in AC–3 or 12 x I in AC–4 Making current: 13 x I in AC-3e			
Rated breaking capacity	I rms conforming to IEC 60947–4–1	Making and breaking current: 8 x I in AC–3 or 10 x I in AC–4 Making and breaking current: 8.5 x I in AC-3e			
Maximum permissible current No current flowing for previous 60 minutes, at ≤ 40 °C (104 °F)	For 10 s	2200 A	2650 A	3600 A	4000 A
	For 30 s	1230 A	1800 A	2400 A	2800 A
	For 1 min	950 A	1300 A	1700 A	2200 A
	For 3 min	620 A	900 A	1200 A	1500 A
	For 10 min	480 A	750 A	1000 A	1200 A
Short-circuit protection by fuses	Fuses for motor application type aM- Ue ≤ 440V	315 A	400 A	500 A	500 A
	Fuses for motor application type aM- Ue ≤ 690V	250 A	250 A	315 A	400 A
	Fuses for general application type gG- Ue ≤ 690V	400 A	500 A	630 A	800 A
Average impedance per pole at Ith and 50 Hz		0.144 mΩ	0.144 mΩ	0.1 mΩ	0.08 mΩ

## LC1G630-800 Pole Characteristics

Poles Characteristics		LC1G630	LC1G800
Number of poles		3 or 4	3 or 4
Rated operational current (Ie) (≤ 440 V)	In AC-3, ≤ 60 °C (140 °F)	630 A	800 A
	In AC-3e, ≤ 60 °C (140 °F)	3P: 555 A 4P: 437 A	3P: 587 A 4P: 555 A
	In AC-1, ≤ 40 °C (104 °F)	1050 A	1050 A
Rated operational voltage (Ue)		Up to 1000 V	
Frequency operating limits with derating		16 2/3 – 400 Hz  Consult your technical support team for application with frequencies other than 50-60 Hz.	
Conventional thermal current (Ith) ≤ 40 °C (104 °F)		1050 A	1050 A
Rated making capacity	I rms conforming to IEC 60947-4-1	Making current: 10 x I in AC-3 or 12 x I in AC-4 Making current: 13 x I in AC-3e	
Rated breaking capacity	I rms conforming to IEC 60947-4-1	Making and breaking current: 8 x I in AC-3 or 10 x I in AC-4 Making and breaking current: 8.5 x I in AC-3e	
Maximum permissible current No current flowing for previous 60 minutes, at ≤ 40 °C (104 °F)	For 10 s	5050 A	5500 A
	For 30 s	4400 A	4600 A
	For 1 min	3400 A	3600 A
	For 3 min	2200 A	2600 A
	For 10 min	1600 A	1700 A
Short-circuit protection by fuses	Fuses for motor application type aM- Ue ≤ 440V	630 A	800 A
	Fuses for motor application type aM- Ue ≤ 690V	500 A	630 A
	Fuses for general application type gG- Ue ≤ 690V	1250 A	1250 A
Average impedance per pole at Ith and 50 Hz		0.065 mΩ	0.065 mΩ

## LC1G250DC Pole Characteristics

Poles Characteristics		LC1G250DC
Number of poles		3
Rated operational current (Ie) (≤ 440 V)	In DC1, ≤ 40 °C (104 °F)	250A, 3 pole in series 200A, 2 pole in series
Rated operational voltage (Ue)		Up to 1500V DC, 3 pole series Up to 1000V DC, 2 pole series
Conventional thermal current (Ith) ≤ 40 °C (104 °F)		250 A
Rated making capacity	I rms conforming to IEC 60947-4-1	Making current: 1.5 x I in DC-1
Rated breaking capacity	I rms conforming to IEC 60947-4-1	Making and breaking current: 1.5 x I in DC-1
Short-circuit protection by fuses	Fuses for aR-	315 A for 250A 250 A for 200A
Average impedance per pole at Ith and 50 Hz		0.17 mΩ

## Advanced Control Module Characteristics

Control Module Characteristics			LC1G115-225	LC1G265-330	LC1G400-500	LC1G630-800	
Rated control circuit voltage $U_c$ ( $U_{cmin}$ - $U_{cmax}$ )			<ul style="list-style-type: none"> <li>• 24–48 Vac/Vdc</li> <li>• 48–130 Vac/Vdc</li> <li>• 200–500 Vac/Vdc</li> </ul> AC: 50/60 Hz			<ul style="list-style-type: none"> <li>• 48–130 Vac/Vdc</li> <li>• 200–500 Vac/Vdc</li> </ul> AC: 50/60 Hz	
Control voltage ( $\leq 60\text{ °C}$ (140 °F))		Operation	0.8 $U_c$ min - 1.1 $U_c$ max				
		Drop-out	0.1 $U_c$ min – 0.45 $U_c$ max				
Inputs compatibility		PLC 24 Vdc type 3 IEC 61131-2	Off-state	0–5 Vdc			
		On-state	11–30 Vdc				
Average consumption at 20 °C (68 °F) and at $U_c$ (3 and 4-pole contactors)	24–48 V control module (BEE)	Inrush	50/60 Hz coil	290 VA	540 VA	490 VA	-
			DC	220 W	380 W	350 W	-
		Sealed	50/60 Hz coil	10 VA	17.9 VA	17.9 VA	-
			DC	5.7 W	6.4 W	6 W	-
	48-130 V control module (EHE)	Inrush	50/60, 400 Hz coil	260 VA	430 VA	450 VA	560 VA
			DC	190 W	360 W	360 W	440 W
		Sealed	50/60, 400 Hz coil	8.9 VA	11.7 VA	11.7 VA	12 VA
			DC	5 W	9 W	8.3 W	8.8 W
	200-500 V control module (LSE)	Inrush	50/60 Hz coil	295 VA	530 VA	535 VA	670
			DC	215 W	300 W	300 W	390 W
		Sealed	50/60 Hz coil	13 VA	16.1 VA	15.4 VA	17 VA
			DC	8 W	9 W	8.6 W	11 W
Operating time		Closing "C"	40-70 ms				
		Opening "O"	15-50 ms				
Mechanical durability at $U_c$ (millions of operating cycles)			8	8	8	5	
Maximum operating rate at ambient temperature $\leq 60\text{ °C}$ (140 °F) (operating cycles per hour)		AC-1	300	300	300	300	
		AC-3/AC-3e	600	600	600	600	
		AC-4	150	150	60	60	
Short-circuit protection		By fuses type gL	24–48 V control module (BEE)	4 A	4 A	4 A	-
			48-130 V control module (EHE)	4 A	4 A	4 A	4 A
			200-500 V control module (LSE)	1 A	1 A	1 A	1 A

## Standard Control Module Characteristics

Control Module Characteristics				LC1G115-225	LC1G265-330	LC1G400-500	LC1G630-800
Rated control circuit voltage $U_c$ ( $U_{cmin}$ - $U_{cmax}$ )				<ul style="list-style-type: none"> <li>48–130 Vac/Vdc</li> <li>100–250 Vac/Vdc</li> <li>200–500 Vac/Vdc</li> </ul> AC: 50/60 Hz			
Control voltage ( $\leq 60\text{ }^\circ\text{C}$ (140 °F))			Operation	0.8 $U_c$ min-1.1 $U_c$ max			
			Drop-out	0.1 $U_c$ min-0.45 $U_c$ max			
Average consumption at 20 °C (68 °F) and at $U_c$ (3 and 4-pole contactors)	48-130 V control module (EHE)	Inrush	50/60 Hz coil	640 VA	780 VA	965 VA	990 VA
			DC	445 W	695 W	760 W	790 W
		Sealed	50/60 Hz coil	17.7 VA	17.6 VA	17.6 VA	17.7
			DC	7.8 W	7.8 W	7.8 W	9.5 W
	100-250 V control module (KUE)	Inrush	50/60 Hz coil	540 VA	700 VA	750 VA	800 VA
			DC	380 W	645 W	660 W	680 W
		Sealed	50/60 Hz coil	12.4 VA	15 VA	15.5 VA	15 VA
			DC	7.8 W	9.1 W	9.3 W	9.5 W
	200-500 V control module (LSE)	Inrush	50/60 Hz coil	295 VA	530 VA	535 VA	670 VA
			DC	215 W	300 W	300 W	390 W
		Sealed	50/60 Hz coil	13 VA	16.1 VA	15.4 VA	17 VA
			DC	8 W	9 W	8.6 W	11 W
Operating time			Closing "C"	40-70 ms			
			Opening "O"	15-50 ms			
Mechanical durability at $U_c$ (millions of operating cycles)				8	8	8	5
Maximum operating rate at ambient temperature $\leq 60\text{ }^\circ\text{C}$ (140 °F) (operating cycles per hour)			AC-1	300	300	300	300
			AC-3/AC-3e	600	600	600	600
			AC-4	150	150	60	60
Short-circuit protection	By fuses type gL	48-130 V control module (EHE)	6 A	6 A	6 A	6 A	
		100-250 V control module (KUE)	2 A	2 A	2 A	2 A	
		200-500 V control module (LSE)	1 A	1 A	1 A	1 A	
		600 V control voltage (XXE)	3 A	3 A	3 A	3 A	

## DC Control Module Characteristics

Control Module Characteristics			LC1G250DC	
Rated control circuit voltage $U_c$ ( $U_{cmin}$ - $U_{cmax}$ )			<ul style="list-style-type: none"> <li>• 24–48 Vac/Vdc</li> <li>• 48–130 Vac/Vdc</li> <li>• 100-250 Vac/Vdc</li> <li>• 200–500 Vac/Vdc</li> </ul> AC: 50/60 Hz	
Control voltage ( $\leq 60\text{ }^\circ\text{C}$ (140 °F))			Operation	0.8 $U_c$ min - 1.1 $U_c$ max
			Drop-out	0.1 $U_c$ min – 0.45 $U_c$ max
Inputs compatibility		PLC 24 Vdc type 3 IEC 61131-2	Off-state	0–5 Vdc
			On-state	11–30 Vdc
Average consumption at 20 °C (68 °F) and at $U_c$ (3 and 4-pole contactors)	24–48 V control module (BEE)	Inrush	50/60 Hz coil	290 VA
			DC	220 W
		Sealed	50/60 Hz coil	10 VA
			DC	5.7 W
	48-130 V control module (EHE)	Inrush	50/60 Hz coil	640 VA
			DC	445 W
		Sealed	50/60 Hz coil	17.7 VA
			DC	7.8 W
	100-250 V control module (KUE)	Inrush	50/60 Hz coil	540 VA
			DC	380 W
		Sealed	50/60 Hz coil	12.4 VA
			DC	7.8 W
	200-500 V control module (LSE)	Inrush	50/60 Hz coil	295 VA
			DC	215 W
		Sealed	50/60 Hz coil	13 VA
			DC	8 W
Operating time			Closing "C"	40-70 ms
			Opening "O"	15-50 ms
Mechanical durability at $U_c$ (millions of operating cycles)				1
Maximum operating rate at ambient temperature $\leq 60\text{ }^\circ\text{C}$ (140 °F) (operating cycles per hour)			DC-1	100
Short-circuit protection		By fuses type gL	24–48 V control module (BEE)	4 A
			48-130 V control module (EHE)	6 A
			100-250 V control module (KUE)	2 A
			200-500 V control module (LSE)	1 A

# Overload Relays Technical Characteristics

## Environmental Characteristics

<b>▲ WARNING</b>
<b>UNINTENDED EQUIPMENT OPERATION</b>
Install and operate overload relays according to the conditions described in the environmental characteristics table.
<b>Failure to follow these instructions can result in death, serious injury, or equipment damage.</b>

Environmental Characteristics		LR9G115–LR9G630
Conforming to standards		<ul style="list-style-type: none"> <li>• IEC 60947–4–1</li> <li>• UL 60947–4–1</li> <li>• CSA C22.2 n° 60947–4–1</li> <li>• GB/T 14048.4</li> </ul>
Product certifications		<ul style="list-style-type: none"> <li>• cULus, CCC, CE Marking, UKCA Marking</li> <li>• EU-RO-MR, Marine Certification by DNV, ATEX</li> </ul>
Degree of protection	Conforming to IEC 60529 and VDE 0106	IP20 with TeSys Giga terminal shrouds.
Climatic withstand		According to IACS E10
Ambient air temperature around the device (conforming to IEC 60255-149)	Storage	–40 to +80 °C ( –40 to 176 °F)
	Normal operation	–25 to +60 °C (–13 to 140 °F)
Maximum operating altitude	Without derating	3000 m (9850 ft)
Shock resistance 1/2 sine wave = 11 ms	Permissible acceleration conforming to IEC 60068–2-27	15 gn
Vibration resistance 5 to 300 Hz	Permissible acceleration conforming to IEC 60068–2-6	6 gn

## Overload Relay Electrical Characteristics

Electrical Characteristics		LR9G115–LR9G630
Rated insulation voltage (Ui)	Conforming to IEC 60947–4–1	1000 V
Rated impulse withstand voltage (Uimp)	Conforming to IEC 60947–4–1	8 kV
Rated operational current (Ie)		28–630 A
Rated frequency		50 – 60 Hz

## Overload Relay Contacts Electrical Characteristics

Electrical Characteristics		LR9G115–LR9G630							
Conventional thermal current		5 A							
Short-circuit protection	By gG or BS fuses or by circuit breaker GB2CD10	6 A							
Maximum sealed power and inrush power consumption of the contactors (occasional operating cycles of contact 95–96)	AC supply	24–480 Vac							
	Sealed	17 VA							
	Inrush	800 VA							
	DC supply	24–250 Vdc							
	Sealed	10 W							
	Inrush	600 W							
Rated operational contact power	AC supply AC-15	<b>V</b>	<b>24</b>	<b>48</b>	<b>120</b>	<b>240</b>	<b>380</b>	<b>480</b>	<b>500</b>
		<b>A</b>	4	4	3	1.5	0.95	0.75	0.72
		<b>VA</b>	96	192	360	360	361	360	360
	DC supply DC-13	<b>V</b>	<b>24</b>	<b>48</b>	<b>125</b>	<b>250</b>	-	-	-
		<b>A</b>	2	0.7	0.22	0.11	-	-	-
		<b>W</b>	48	33.6	27.5	27.5	-	-	-
Maximum operational voltage	AC category AC-15	<b>V</b>	500						
	DC category DC-13	<b>V</b>	250						

# Contactor Accessory Technical Characteristics

## Auxiliary Contacts Electrical Characteristics

Auxiliary contacts electrical characteristics		LAG8N113 / LAG8N203 / LAG8N113P / LAG8N203P
Conventional thermal current		10 A
Short-circuit protection	By gG or BS fuses or by circuit breaker GB2CD16	10 A
Maximum sealed and inrush power consumption of the contactors (occasional operating cycles of contact 95–96)	AC supply	24–600 Vac
	Sealed	17 VA
	Inrush	800 VA
	DC supply	24–500 Vdc
	Sealed	10 W
	Inrush	600 W

## Category AC-15

Operating cycles	V	24	48	115	230	400	500
1 million	VA	60	120	280	560	800	500
2 million	VA	24	48	115	230	400	250
3 million	VA	16	32	80	160	280	150

## Category DC-13

Operating cycles	V	24	48	125	250	440
0.5 million	W	100	100	105	110	88
1 million	W	48	72	54	54	55
2 million	W	24	36	38	38	39
3 million	W	16	24	25	25	33

## Remote Wear Diagnostic Module Characteristics

Electrical characteristics		LA9GRD01 / LA9GRD10				
Conventional thermal current		5 A				
Short-circuit protection	By gG or BS fuses or by circuit breaker GB2CD10	6 A				
Rated operational contact power	AC supply AC-15	V	24	48	120	240
		A	4	4	3	1.5
		VA	96	192	360	360
	DC supply DC-13	V	24	48	125	250
		A	2	0.7	0.22	0.11
		W	48	33.6	27.5	27.5
Maximum operational voltage	AC supply AC-15	V	500			
	DC supply DC-13	V	250			

## Electromagnetic Compatibility

The table below describes the electromagnetic compatibility of the TeSys Control-Giga contactors and TeSys Protect-Giga electronic overload relays:

Phenomenon	Basic standard	Product compliance
Electrostatic discharge	IEC 61000-4-2	Air Discharge: 8 kV + 10% Contact discharge: 6 kV +10%
Radiated electromagnetic field	IEC 61000-4-3	Field strength: 20 V/m +5 V/m Frequency: 80 MHz or 6 GHz
		Field strength: 20 V/m +5 V/m Frequency: 1.0 GHz or 1.4 GHz
		Field strength: 20 V/m +5 V/m Frequency: 1.4 GHz or 2.0 GHz
		Field strength: 20 V/m +5 V/m Frequency: 2.0 GHz or 2.7GHz
		Field strength: 20 V/m +5 V/m Frequency: 2.7 GHz ; 3.0 GHz
		Field strength: 20 V/m +5 V/m Frequency: 3.0 GHz ; 5.9 GHz
		Field strength: 20 V/m +5 V/m Frequency: ISM-GSM
		Fast transient burst
Power DC < 50 V-2 kV +0.5 kV / 5 min		
PLC interface-2 kV +0.5 kV 5 min full level		
Surge immunity	IEC 61000-4-5	Power AC and DC > 50 V (A1 A2)-4 kV +10% CM 12 Ω and 2 kV +10% DM 2 Ω
		Power AC and DC > 50 V (A1 A2)-2 kV +10% CM 12 Ω and 1 kV +10% DM 2 Ω
		PLC interface (X1 X2 X3)-2 kV +10% CM 42 Ω and 1 kV +10% DM 42 Ω
Conducted electromagnetic field	IEC 61000-4-6	Conducted Disturbance [0,15MHz ; 80MHz] ISM frequencies-20 V rms +5 V
Magnetic field	IEC 61000-4-8	300 A/m permanent (1 min)
		1000 A/m impulse (3 s)
Conducted emission	EN 55011	Class A
Radiated emission	EN 55011	Class A

## Short-Circuit Current Ratings (SCCR)

For use in North America, according to UL and CSA standards.

### Minimum Enclosure Size

TeSys Giga device		Minimum enclosure size
Contactor	LC1G115	20 x 12 x 8 in.
	LC1G150	20 x 12 x 8 in.
	LC1G185	20 x 12 x 8 in.
	LC1G225	20 x 12 x 8 in.
	LC1G265	24 x 12 x 10 in.
	LC1G330	24 x 12 x 10 in.
	LC1G400	24 x 12 x 10 in.
	LC1G500	36 x 24 x 10 in.
	LC1G630	48 x 36 x 12 in.
	LC1G800	48 x 36 x 12 in.
Overload relay	LR9G115	14 x 8 x 6 in.
	LR9G225	14 x 8 x 6 in.
	LR9G500	16 x 10 x 6 in.
	LR9G630	20 x 16 x 10 in.

### SCCR for Contactors at 600 V

Contactor	Circuit breaker size	Voltage	Standard Fault SCCR	High-Fault SCCR
LC1G115	300 A	600 V	10 kA	50 kA
LC1G150	300 A	600 V	10 kA	50 kA
LC1G185	300 A	600 V	10 kA	50 kA
LC1G225	400 A	600 V	10 kA	50 kA
LC1G265	500 A	600 V	10 kA	50 kA
LC1G330	600 A	600 V	18 kA	50 kA
LC1G400	600 A	600 V	18 kA	50 kA
LC1G500	600 A	600 V	30 kA	50 kA

## SCCR for Contactors at 480 V

Contactor	Circuit breaker size	Voltage	Standard Fault SCCR	High-Fault SCCR
LC1G115	300 A	480 V	10 kA	100 kA
LC1G150	300 A	480 V	10 kA	100 kA
LC1G185	300 A	480 V	10 kA	100 kA
LC1G225	400 A	480 V	10 kA	100 kA
LC1G265	500 A	480 V	10 kA	100 kA
LC1G330	600 A	480 V	18 kA	100 kA
LC1G400	700 A	480 V	18 kA	65 kA
LC1G500	600 A	480 V	30 kA	65 kA
LC1G630	1000 A	480 V	42 kA	100 kA
LC1G800	1200 A	480 V	42 kA	100 kA

## SCCR for Overload Relays

Overload relay	Circuit breaker size	Voltage	Standard Fault SCCR	High-Fault SCCR
LR9G115	225 A	600 V	10 kA	100 kA
LR9G225	400 A	600 V	18 kA	100 kA
LR9G500	600 A	600 V	30 kA	100 kA
LR9G630	1000 A	480 V	42 kA	100 kA

# Installation

## What's in This Chapter

Contactors Customization.....	72
TeSys Giga Contactor Mounting on Plate .....	75
TeSys Giga Electronic Overload Relay Mounting on Plate .....	79
TeSys Giga Contactor Mounting on Retrofit Base.....	81
TeSys Giga Contactor and TeSys Giga Overload Relay Direct Mounting .....	85
TeSys Giga Contactor Assembly with TeSys Giga Overload Relay Separately Mounted .....	92
Identification with Clip-On Marker Holder.....	94

# Contactor Customization

## Overview

Cable memory connection blocks enable contactor replacement without disconnection of the power connections.

Cable memory connection blocks are installed on 3-pole and 4-pole advanced contactors. They can be installed as an option on 3-pole and 4-pole standard contactors.

Description	Compatible with contactors	Cable memory reference
Cable memory for 3-pole contactors - for holding cables in place when replacing contactor	LC1G115-225	LA9G3101
	LC1G265-500	LA9G3102
	LC1G630-800	LA9G3103
Cable memory for 4-pole contactors - for holding cables in place when replacing contactor	LC1G115-225	LA9G4101
	LC1G265-500	LA9G4102
	LC1G630-800	LA9G4103

This section describes the cable memory connection blocks installation on the standard contactor.

# Cable Memory Connection Blocks Installation on Standard Contactor

1. Place the screwdriver on the contactor power terminals to remove the snap-in nut.
  2. Twist the screwdriver clockwise.
  3. Pull the snap-in nut outwards to remove it.
- NOTE:** Remove all the six nuts in similar way. Keep the lock nuts aside for further use.
4. Place the cable memory connection blocks on the contactor power terminals.
  5. Push inwards to lock it automatically with a click.
  6. Place the lock nut back on the power terminals of the cable memory.
  7. Tighten the screws at the right torque.

Contactor	Torque	Tool	Screws
LC1G115–225	18±1.8 N•m (159±15.9 lb-in)	Allen key	M8
LC1G265–500	35±3.5 N•m (310±31 lb-in)	Inner hexagon	M10
LC1G630–800	58±5.8 N•m (513±51.3 lb-in)	Inner hexagon	M12

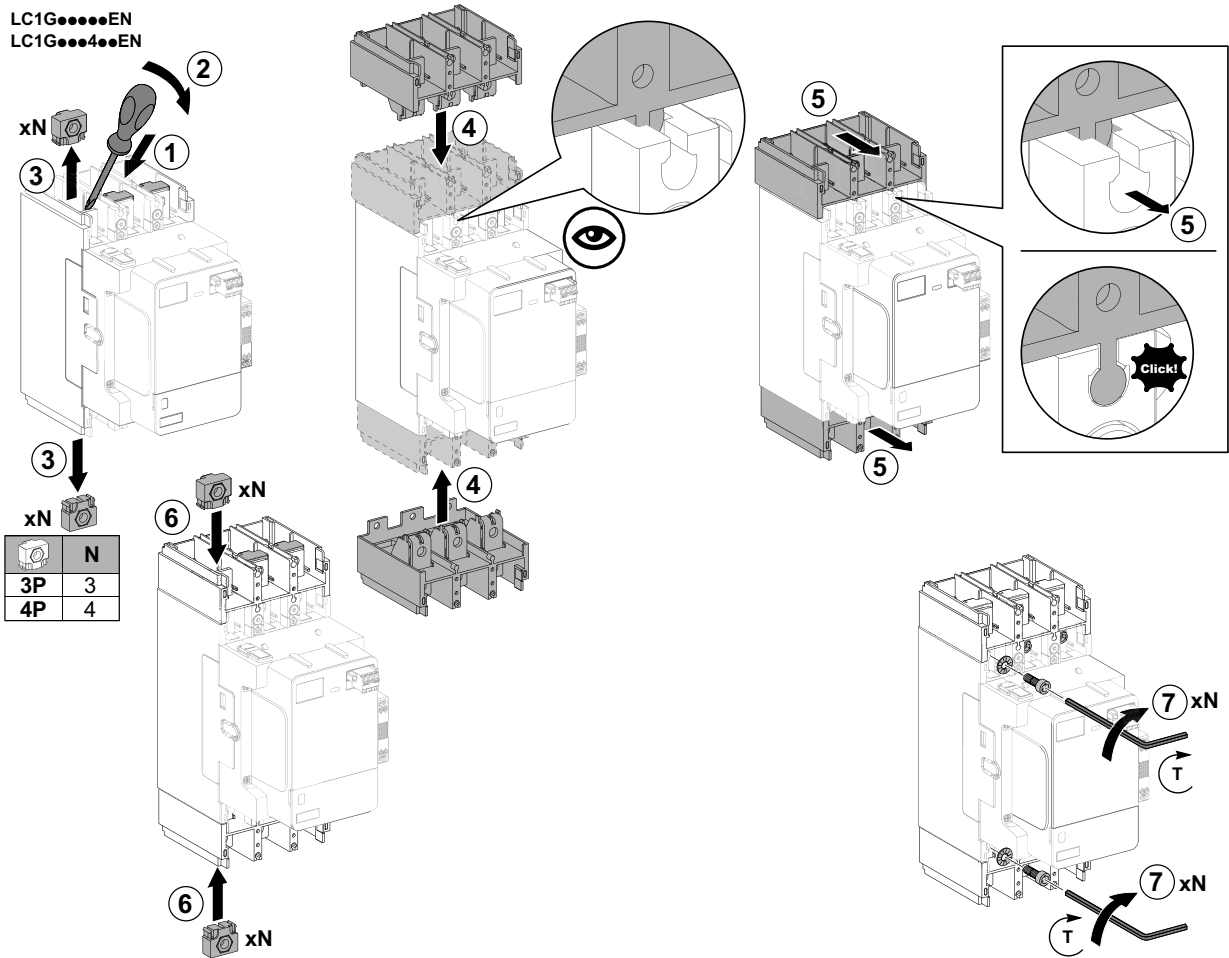

## Cable Memory Connection Block Installation Video

To access a demonstration video about installing the cable memory connection blocks on a standard contactor, you can [click here](#), scan the QR code, or copy and paste the link to your Web browser.

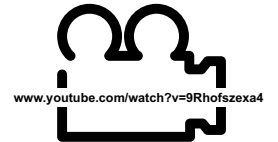

## TeSys Giga Contactor Mounting on Plate

### ⚠ DANGER

#### HAZARD OF ELECTRIC SHOCK, EXPLOSION OR ARC FLASH

Install the contactor so that the minimum clearance to grounded metal is maintained.

**Failure to follow these instructions will result in death or serious injury.**

The contactor can be mounted

- either on a plate drilled with simple holes, using the screws, washers and nuts delivered with the contactors
- or on a plate drilled with threaded holes, using only screws adapted to the threaded holes.

**NOTE:** It is recommended to use a steel plate with minimum thickness of 2 mm (0.08 in.).

## TeSys Giga Contactor Mounting Video

To access a demonstration video about mounting a contactor on plate, you can click [here](#), scan the QR code, or copy and paste the link to your Web browser.

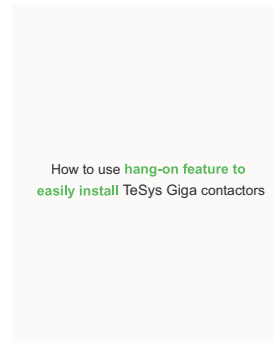

## Mounting LC1G115-250 Contactors on Plate

Perform the following procedure to mount the LC1G115-225 and LC1G250DC contactors on the plate.

1. Drill 4 holes in the plate. Hole diameter: 4.5 to 6 mm (0.17 to 0.23 in.).
2. Insert the two short screws (A) diagonally on the plate and tighten the screws with PH2 screwdriver at the right torque.
3. Place the contactor on the short screw heads.
4. Insert the two long screws (B) diagonally through the contactor and tighten them at the right torque.

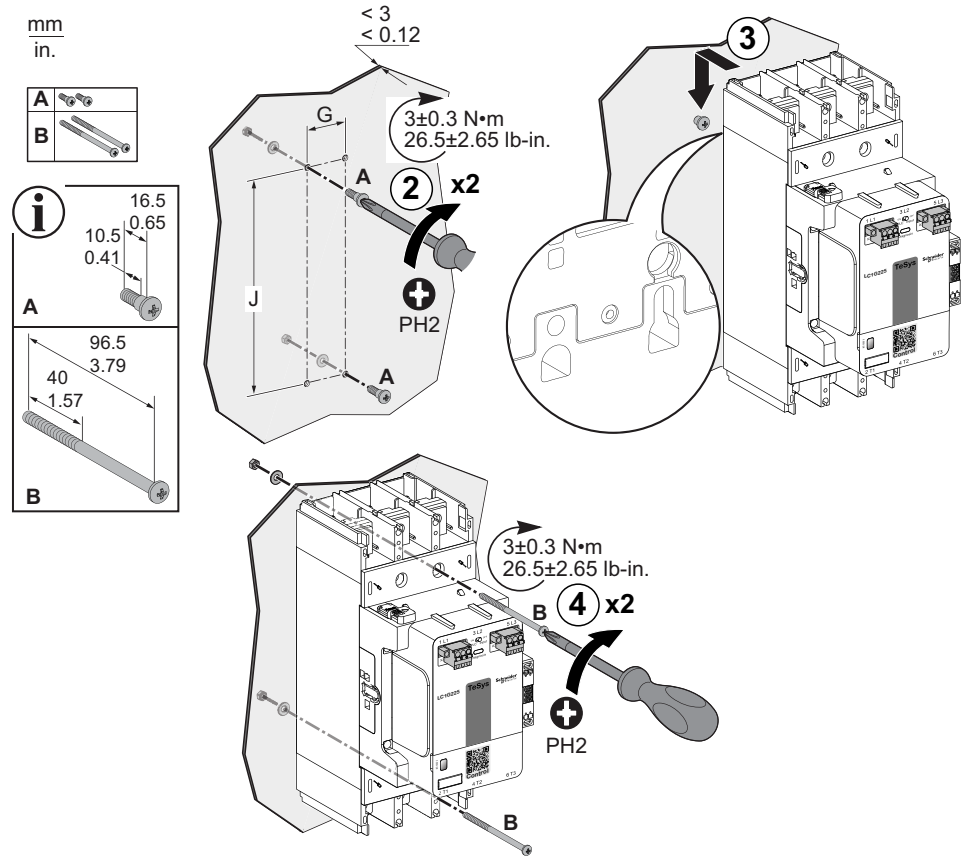

Contactor	Number of poles	G	J	Screws
LC1G115–225	3P	35 mm (1.38 in.)	166 mm (6.53 in.)	M5
	4P	70 mm (2.75 in.)	166 mm (6.53 in.)	M5
LC1G250DC	3P	35 mm (1.38 in.)	166 mm (6.53 in.)	M5

**NOTE:** The four screws with nuts and washers are delivered with contactors.

## Mounting LC1G265-500 Contactors on Plate

Perform the following procedure to mount the LC1G265-500 contactors on the plate.

1. Drill 4 holes in the plate. Maximum hole diameter: 6 mm (0.23 in.).
2. Insert the two short screws (A) diagonally on the plate. The distance between the panel and screw head flat surface shall be between 6 and 14 mm (0.23 and 0.55 in.).
3. Place the contactor on the short screw heads.
4. Tighten the two short screws (A) with PZ2 screwdriver at the right torque.
5. Insert the two long screws (B) diagonally through the contactor and tighten them at the right torque.

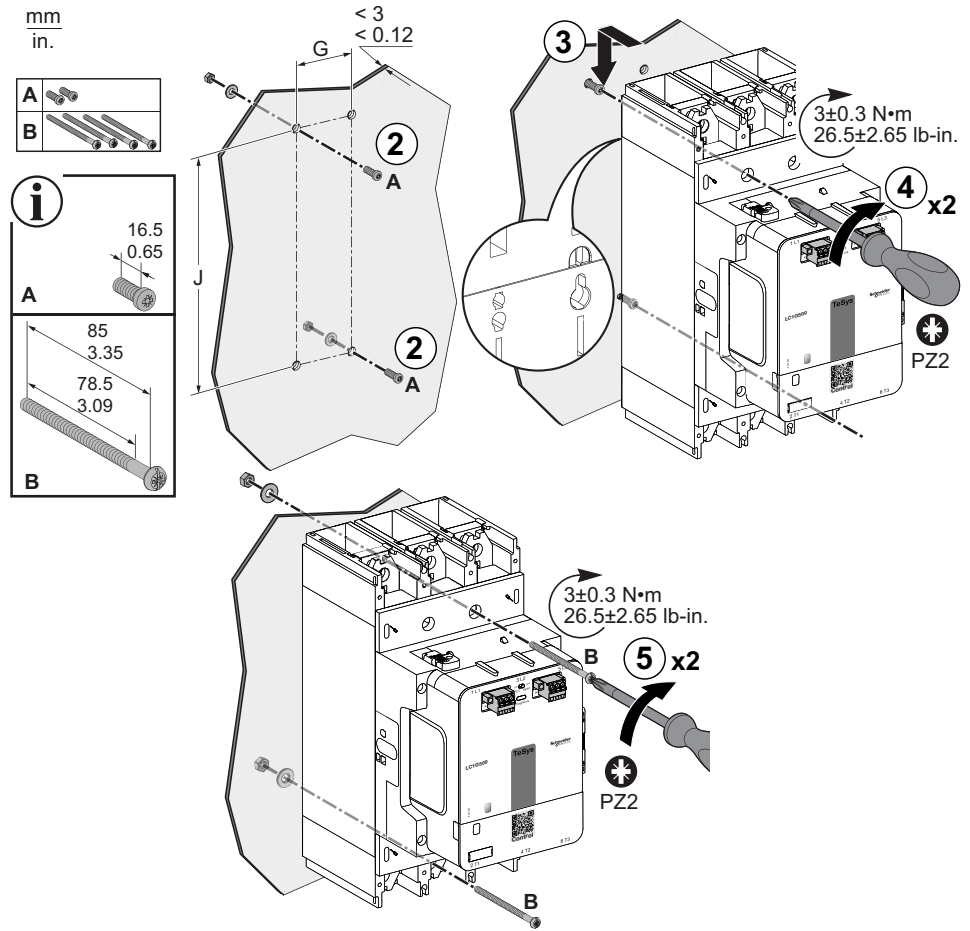

Contactor	Number of poles	G	J	Screws
LC1G265–500	3P	45 mm (1.77 in.)	187 mm (7.36 in.)	M5
	4P	90 mm (3.54 in.)	187 mm (7.36 in.)	M5

**NOTE:** The screws with nuts and washers are delivered with contactors.

**NOTE:** Contactor can also be mounted using four long screws instead of two short screws and two long screws.

## Mounting LC1G630-800 Contactors on Plate

Perform the following procedure to mount the LC1G630-800 contactors on the plate.

1. Drill 4 holes in the plate. Maximum hole diameter: 9 mm (0.35 in.).
2. Insert the two short screws (A) diagonally on the plate. The distance between the panel and screw head flat surface shall be between 16 and 24 mm (0.62 and 0.94 in.).
3. Place the contactor on the short screw heads.
4. Tighten the two short screws (A) with PH3 screwdriver at the right torque.
5. Insert the two long screws (B) diagonally through the contactor and tighten them at the right torque.

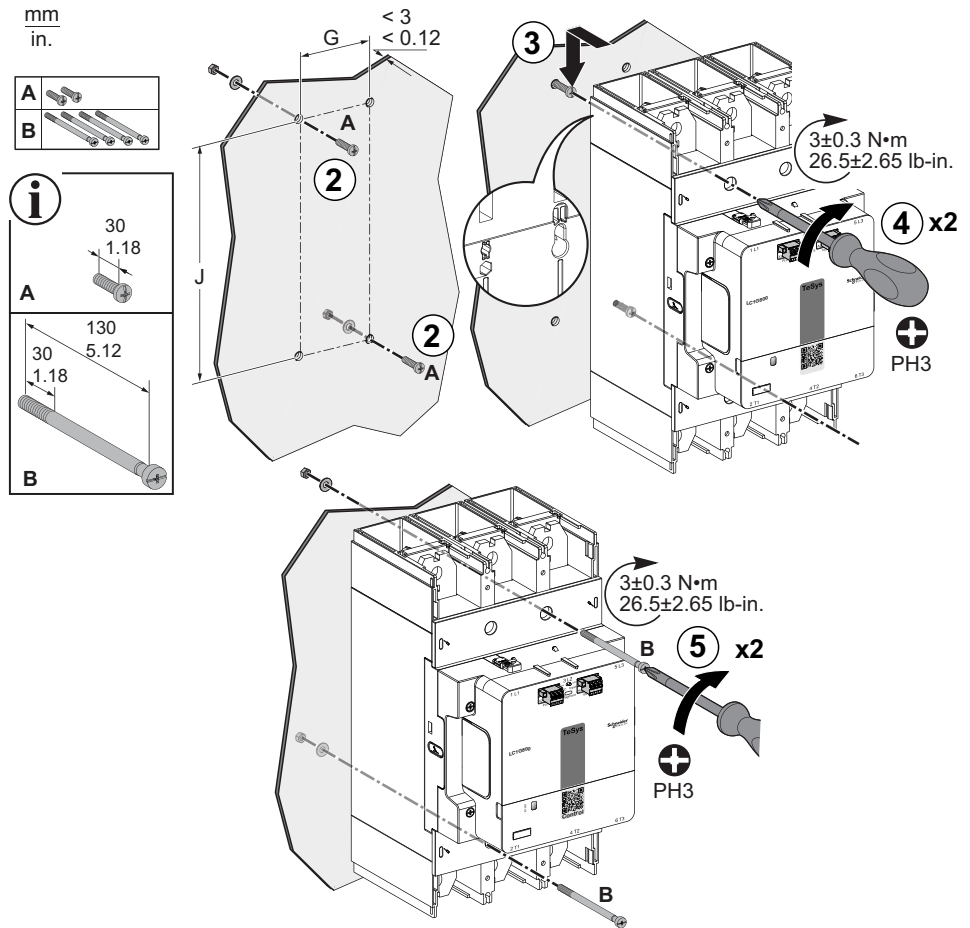

Contactor	Number of poles	G	J	Screws
LC1G630–800	3P	70 mm (2.75 in.)	242 mm (9.52 in.)	M8
	4P	140 mm (5.50 in.)	242 mm (9.52 in.)	M8

**NOTE:** The screws with nuts and washers are delivered with contactors.

**NOTE:** Contactor can also be mounted using four long screws instead of two short screws and two long screws.

# TeSys Giga Electronic Overload Relay Mounting on Plate







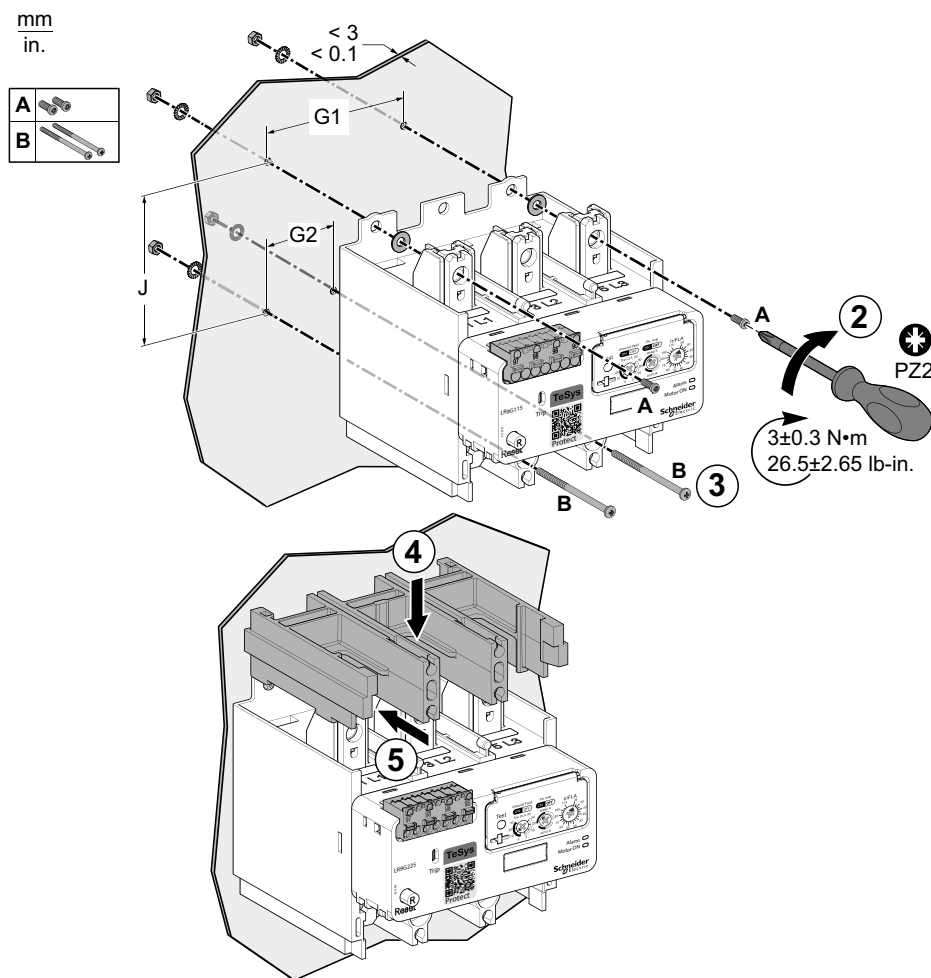

Perform the following procedure to mount the overload relays on the plate.

1. Drill 4 holes in the plate, with respect of the dimensions given.
  - LR9G115-500 - Maximum hole diameter: 6 mm (0.23 in.)
  - LR9G630 - Maximum hole diameter: 9 mm (0.35 in.)
2. Use the two short screws (A) to fix the top side of the overload relay and tighten the screws with PZ2 screwdriver at the right torque.

**NOTE:** For short screws, the screwdriver should be inserted through the power terminal holes to tighten the screws.

3. Use the two long screws (B) to fix the bottom side of the overload relay and tighten them at the right torque
4. Place the phase separator adaptor on the overload relay from the top.
5. Push the adaptor inwards to lock it with a click.



Overload relay	A			B		
	X	Y		X	Y	
LR9G115-225	16 mm (0.63 in.)	16 mm (0.63 in.)	 PZ2	96.5 mm (3.79 in.)	40 mm (1.57 in.)	 PH2
LR9G500	16 mm (0.63 in.)	16 mm (0.63 in.)	 PZ2	85 mm (1.38 in.)	78.5 mm (3.09 in.)	 PZ2
LR9G630	20 mm (0.78 in.)	20 mm (0.78 in.)	 PH3	130 mm (5.12 in.)	30 mm (1.18 in.)	 PH3

Overload relay	G1	G2	J	Screws
LR9G115-225	70 mm (2.75 in.)	35 mm (1.38 in.)	80.10 mm (3.14 in.)	M5
LR9G500	119 mm (4.70 in.)	45 mm (1.8 in.)	68.25 mm (2.75 in.)	M5
LR9G630	186 mm (7.30 in.)	70 mm (2.75 in.)	96.10 mm (3.80 in.)	M8

**NOTE:** The four screws with nuts and washers are delivered with overload relay.

# TeSys Giga Contactor Mounting on Retrofit Base

## Overview

Retrofit bases are designed for integrating TeSys Giga contactors into installations using TeSys F contactors. The retrofit bases help reduce replacement and reinstallation time when you upgrade your system with the new range of TeSys Giga contactors. The bases come in three frame sizes.

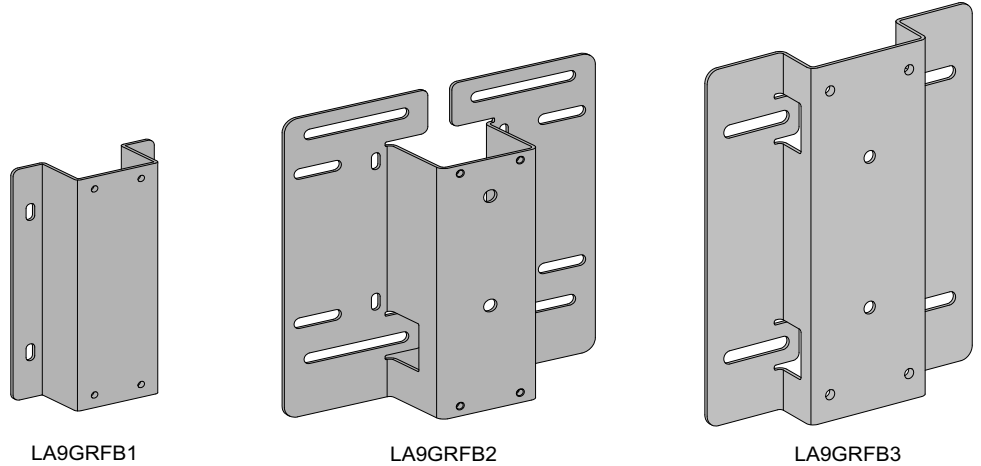

Contactor	Retrofit base
LC1G115-225	LA9GRFB1
LC1G265-500	LA9GRFB2
LC1G630-800	LA9GRFB3

## Mounting Dimensions

$\frac{\text{mm}}{\text{in.}}$  LA9GRFB1: LC1G115-225

TeSys F  
LC1F115-225

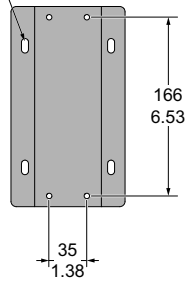

LA9GRFB2: LC1G265-500

TeSys F  
LC1F265-330

TeSys F  
LC1F400-500

TeSys F  
LC1F400-500

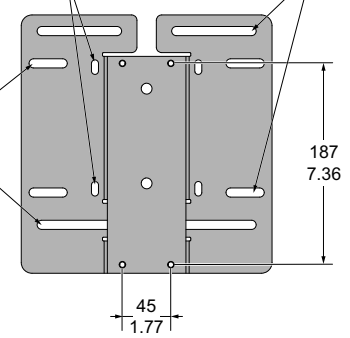

LA9GRFB3: LC1G630-800

TeSys F: LC1F630-800

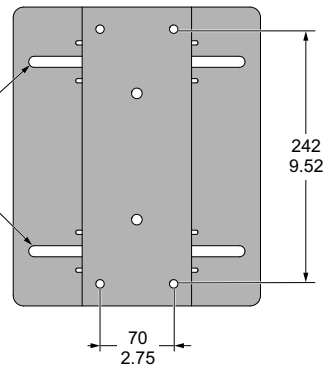

## Retrofit TeSys F with TeSys Giga Contactor Video

To access a demonstration video about retrofitting TeSys F with TeSys Giga contactor, you can click [here](#), scan the QR code, or copy and paste the link to your Web browser.



## Installation Procedure

Perform the following procedure to install a TeSys Giga contactor on the retrofit base.

1. Remove the four mounting screws from the fixing holes of the TeSys F contactor.
2. Remove the TeSys F contactor.
3. Place the retrofit base on the fixing holes of the TeSys F contactor. Use the holes on the retrofit base corresponding to the TeSys F contactor to replace, as indicated on TeSys Giga Contactor Mounting on Retrofit Base, page 81.
4. Insert and tighten the four mounting screws with PZ2 screwdriver at the right torque.

**NOTE:** Use the screws of the TeSys F contactor to install the retrofit base.

5. Insert and tighten the two short screws (A) half way diagonally on the retrofit base.
6. Place the TeSys F contactor on the short screws head.

7. Insert and tighten the long screws (B) with PZ2 screwdriver at the right torque.

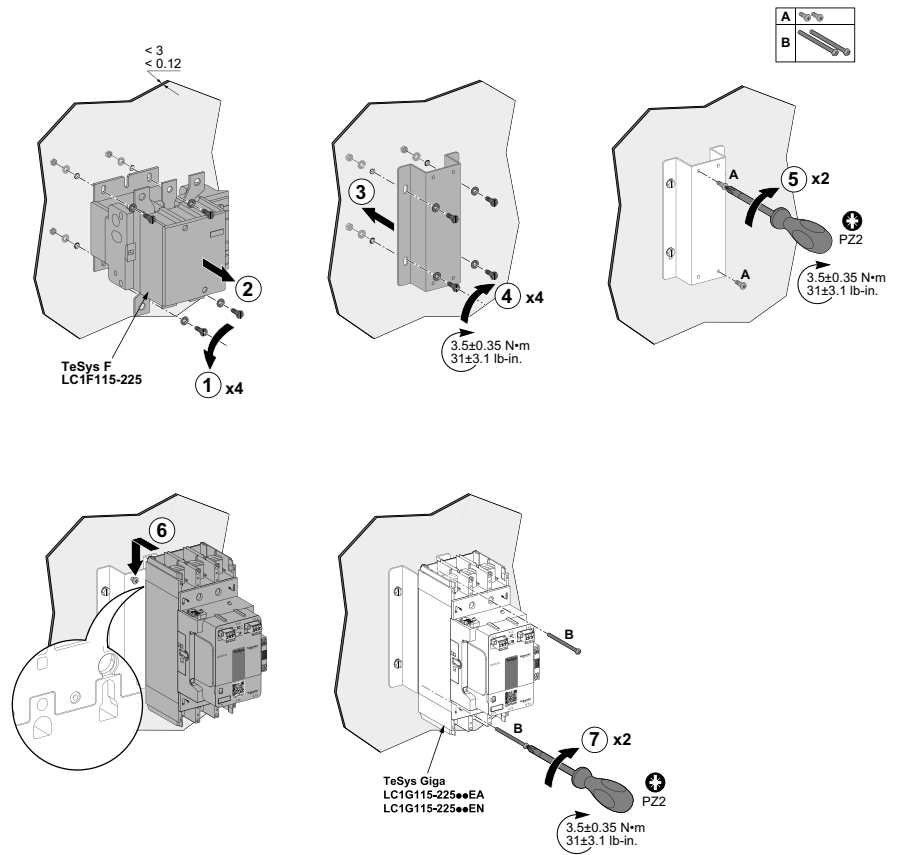

# TeSys Giga Contactor and TeSys Giga Overload Relay Direct Mounting

## Overview

This section describes the assembly of the overload relays directly on the 3-pole advanced or standard contactors. The overload relays are mounted downstream of the contactors.

- LR9G115 and LR9G225 overload relays can be assembled with LC1G115–225 contactors.
- LR9G500 overload relay can be assembled with LC1G265–500 contactors.
- LR9G630 overload relay can be assembled with LC1G630–800 contactors.

## Advanced Contactors Assembled with Overload Relay

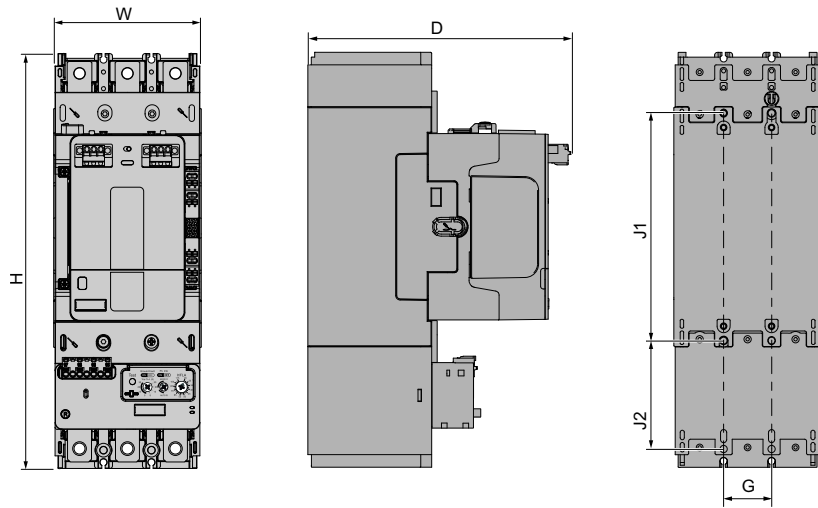

The table below provides the dimension detail for mounting:

Advanced Contactor	Overload relay	W	D	H	G	J1	J2
LC1G115–225	LR9G115–225	108 mm (4.25 in.)	193 mm (7.59 in.)	303 mm (11.92 in.)	35 mm (1.37 in.)	166 mm (6.53 in.)	79.15 mm (3.11 in.)
LC1G265–500	LR9G500	140 mm (5.51 in.)	225 mm (8.85 in.)	341 mm (13.42 in.)	45 mm (1.77 in.)	187 mm (7.36 in.)	92.85 mm (3.65 in.)
LC1G630–800	LR9G630	210 mm (8.26 in.)	265 mm (10.43 in.)	436 mm (17.17 in.)	70 mm (2.75 in.)	242 mm (9.52 in.)	102.18 mm (4.02 in.)

## Standard Contactors Assembled with Overload Relay

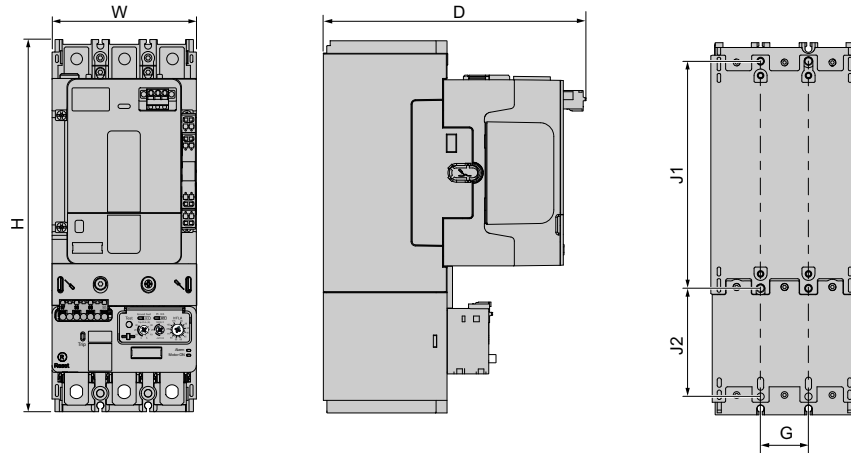

The table below provides the dimension detail for mounting:

Standard Contactor	Overload relay	W	D	H	G	J1	J2
LC1G115-225	LR9G115-225	108 mm (4.25 in.)	193 mm (7.59 in.)	272 mm (10.70 in.)	35 mm (1.37 in.)	166 mm (6.53 in.)	79.15 mm (3.11 in.)
LC1G265-500	LR9G500	140 mm (5.51 in.)	225 mm (8.85 in.)	308.5 mm (12.14 in.)	45 mm (1.77 in.)	187 mm (7.36 in.)	92.85 mm (3.65 in.)
LC1G630-800	LR9G630	210 mm (8.26 in.)	265 mm (10.43 in.)	384 mm (15.12 in.)	70 mm (2.75 in.)	242 mm (9.52 in.)	102.18 mm (4.02 in.)

## Overload Relay Direct Mounting Video

### Direct Mounting on Advanced Contactor

To access a demonstration video about the assembly of an overload relay directly on a 3-pole advanced contactor, you can click [here](#), scan the QR code, or copy and paste the link to your Web browser.

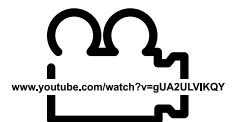
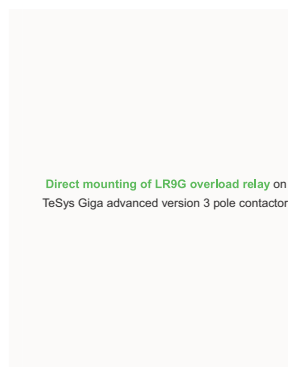

## Direct Mounting on Standard Contactor

To access a demonstration video about the assembly of an overload relay directly on a 3-pole standard contactor, you can click [here](#), scan the QR code, or copy and paste the link to your Web browser.

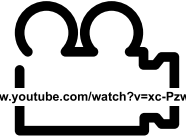
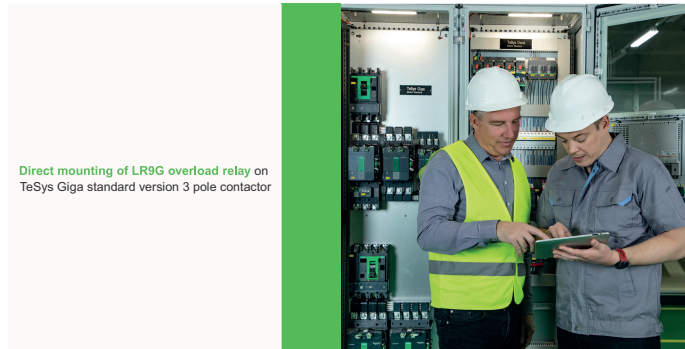

[www.youtube.com/watch?v=xc-Pzw1uG6M](https://www.youtube.com/watch?v=xc-Pzw1uG6M)

## Assembly Procedure

### ⚠ CAUTION

#### HAZARD OF FALLING

Always use the screws to secure the overload relay to the contactor.

**Failure to follow these instructions can result in injury or equipment damage.**

Perform the following procedure to mount the overload relay on the contactor:

**NOTE:** Mount the overload relay together with the contactor before installing the assembly on the plate.

1. **On advanced contactor:** remove the cable memory from the downstream power terminals of the contactor.  
**On standard contactor:** remove the 3 nut holders using a screwdriver from the downstream power terminals of the contactor.
2. Push the phase adaptor outwards.
3. Remove the phase adaptor from the overload relay.
4. Place the overload relay downstream of the contactor .
5. Push the overload relay inwards to lock it automatically with a click.
6. Place the screws at the power terminals of the contactor and tighten them at the right torque.

Contactor	Overload relay	Tool	Torque	Screws
LC1G115-225	LR9G115-225	Allen key	18±1.8 N•m (159±15.9 lb-in)	M8
LC1G265-500	LR9G500	Inner hexagon	35±3.5 N•m (310±31 lb-in)	M10
LC1G630-800	LR9G630	Inner hexagon	58±5.8 N•m (513±51.3 lb-in)	M12

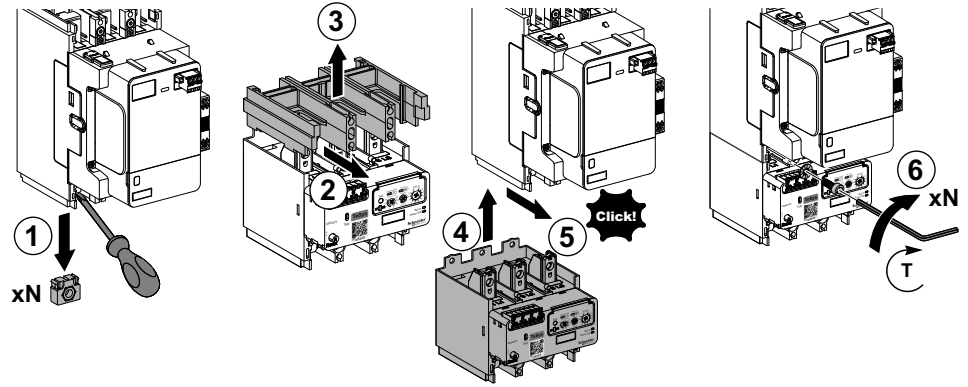

## IP20 Optional Protection Cover

The IP20 protection cover is an optional protection cover which is used to cover the main power terminals between contactor and overload relay when mounted together.

The table below shows the compatibility of the protection cover with contactors and overload relays:

Contactor	Overload relay	IP20 cover reference
LC1G115-225	LR9G115-225	LA9G3704
LC1G265-500	LR9G500	LA9G3705
LC1G630-800	LR9G630	LA9G3706

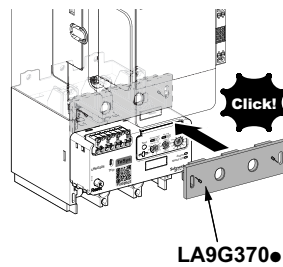

## Assembly Installation of LC1G115–225 Contactor and Overload Relay on Plate

After assembling LC1G115–225 contactor and LR9G115–225 overload relay (see Assembly Procedure, page 87), perform the following procedure to mount the assembly on the plate:

1. Drill 6 holes in the plate. Maximum hole diameter: 6 mm (0.23 in.)
  - NOTE:** To ease the mounting, drilling stencils JYT1902701 can be downloaded from the [www.se.com](http://www.se.com) website.
2. Insert the two short screws (A) half way diagonally on the plate and tighten the screws with PH2 screwdriver at the right torque.
3. Place the contactor and overload relay on the short screw heads.
4. Insert the two long screws (B) diagonally through the contactor and another two screws to fix the overload relay and then tighten them at the right torque.

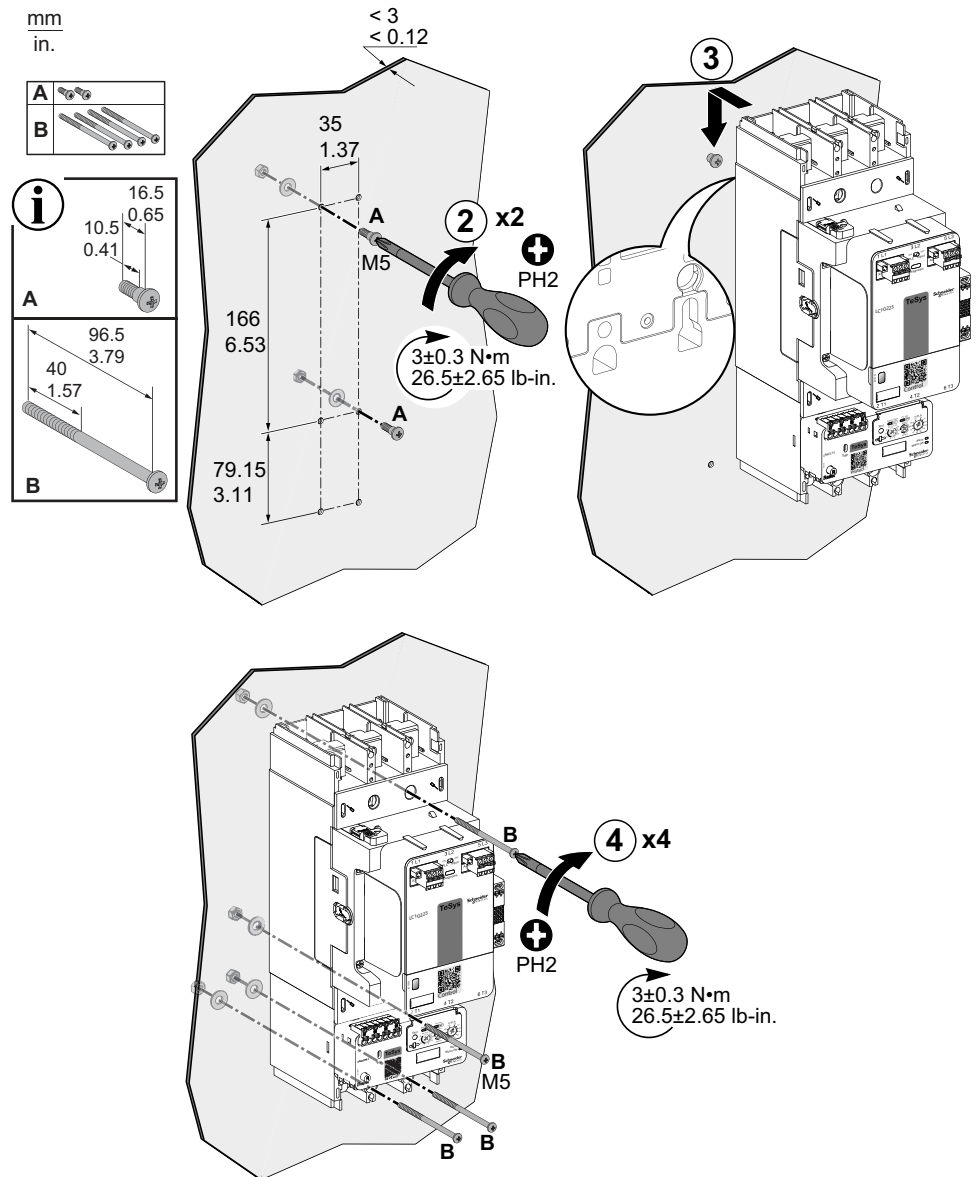

## Assembly Installation of LC1G265–500 Contactor and Overload Relay on Plate

After assembling LC1G265–500 contactor and LR9G500 overload relay (see Assembly Procedure, page 87), perform the following procedure to mount the assembly on the plate:

1. Drill 6 holes in the plate. Maximum hole diameter: 6 mm (0.23 in.)
 

**NOTE:** To ease the mounting, drilling stencils JYT1902701 can be downloaded from the [www.se.com](http://www.se.com) website.
2. Insert the two short screws (A) half way diagonally on the plate.
3. Place the contactor and overload relay on the short screw heads.
4. Tighten the two short screws with PZ2 screwdriver at the right torque.
5. Insert the two long screws (B) diagonally through the contactor and another two screws to fix the overload relay and then tighten them at the right torque.

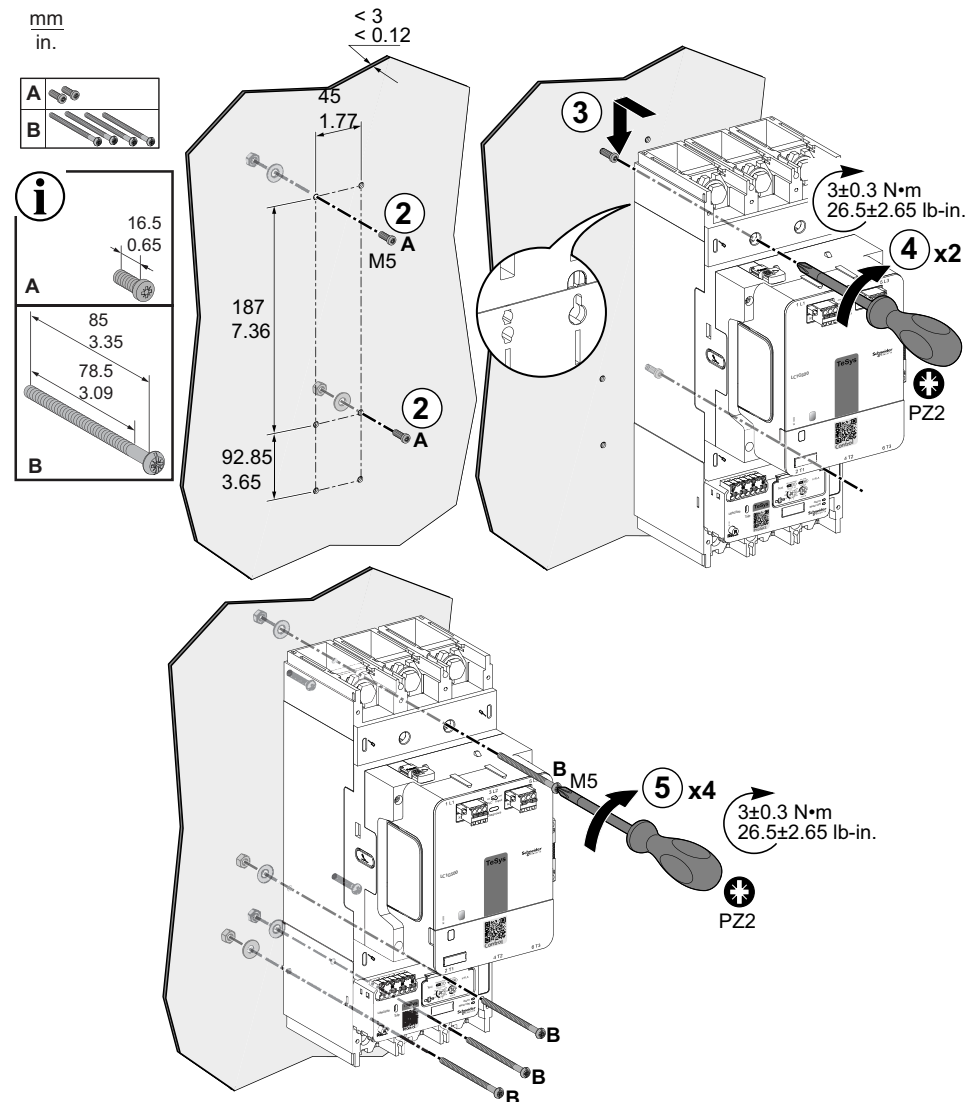

## Assembly Installation of LC1G630–800 Contactor and Overload Relay on Plate

After assembling LC1G630–800 contactor and LR9G630 overload relay (see Assembly Procedure, page 87), perform the following procedure to mount the assembly on the plate:

1. Drill 6 holes in the plate. Maximum hole diameter: 9 mm (0.35 in.)
  - NOTE:** To ease the mounting, drilling stencils JYT1902701 can be downloaded from the [www.se.com](http://www.se.com) website.
2. Insert the two short screws (A) half way diagonally on the plate.
3. Place the contactor and overload relay on the short screw heads.
4. Tighten the two short screws with PH3 screwdriver at the right torque.
5. Insert the two long screws (B) diagonally through the contactor and another two screws to fix the overload relay and then tighten them at the right torque.

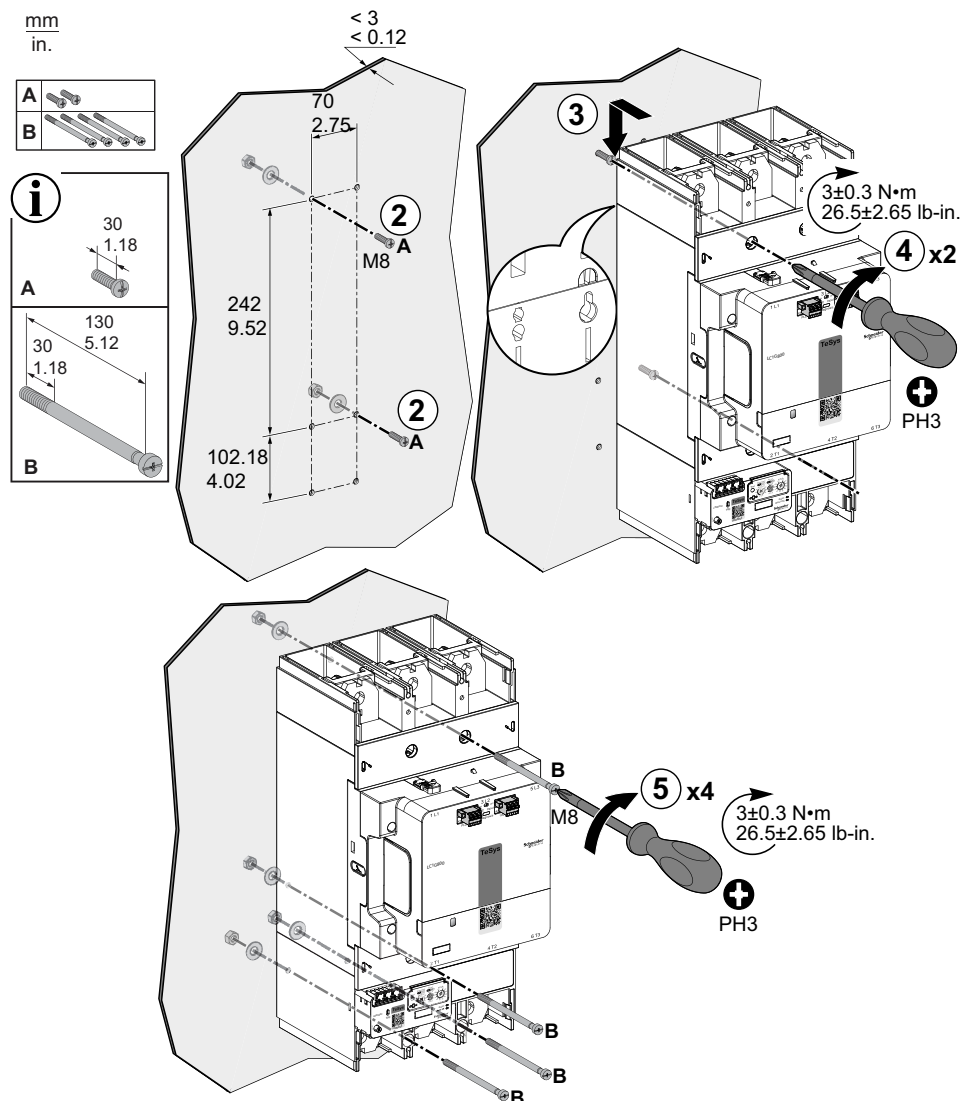

# TeSys Giga Contactor Assembly with TeSys Giga Overload Relay Separately Mounted

## Overview

The mounting base is used for separately mounting of overload relay beneath contactor to align the main power pole connections of the contactor and the overload relay, to allow connection between the contactor and the overload relay with straight bars.

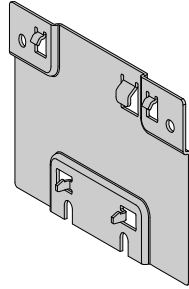

Description	Mounting base reference
Mounting base for alignment of LR9G115-225 with LC1G115-225	LA9G3650
Mounting base for alignment of LR9G500 with LC1G265-330	LA9G3651
Mounting base for alignment of LR9G500 with LC1G400-500	LA9G3652
Mounting base for alignment of LR9G630 with LC1G630-800	LA9G3653

## Installation Procedure

Perform the following procedure to install the mounting base on the overload relay.

1. Push outwards the phase separator adaptor from the overload relay.
2. Remove the phase separator adaptor and keep aside for further use
3. Place the mounting base on the top hooks at the back of the overload relay.
4. Push it inwards to lock the mounting base automatically with the bottom hooks of the overload relay.
5. Place the phase separator adaptor back on the overload relay.
6. Push it inwards to lock it automatically with a click.
7. Connect the overload relay downstream of the contactor using the straight bars.

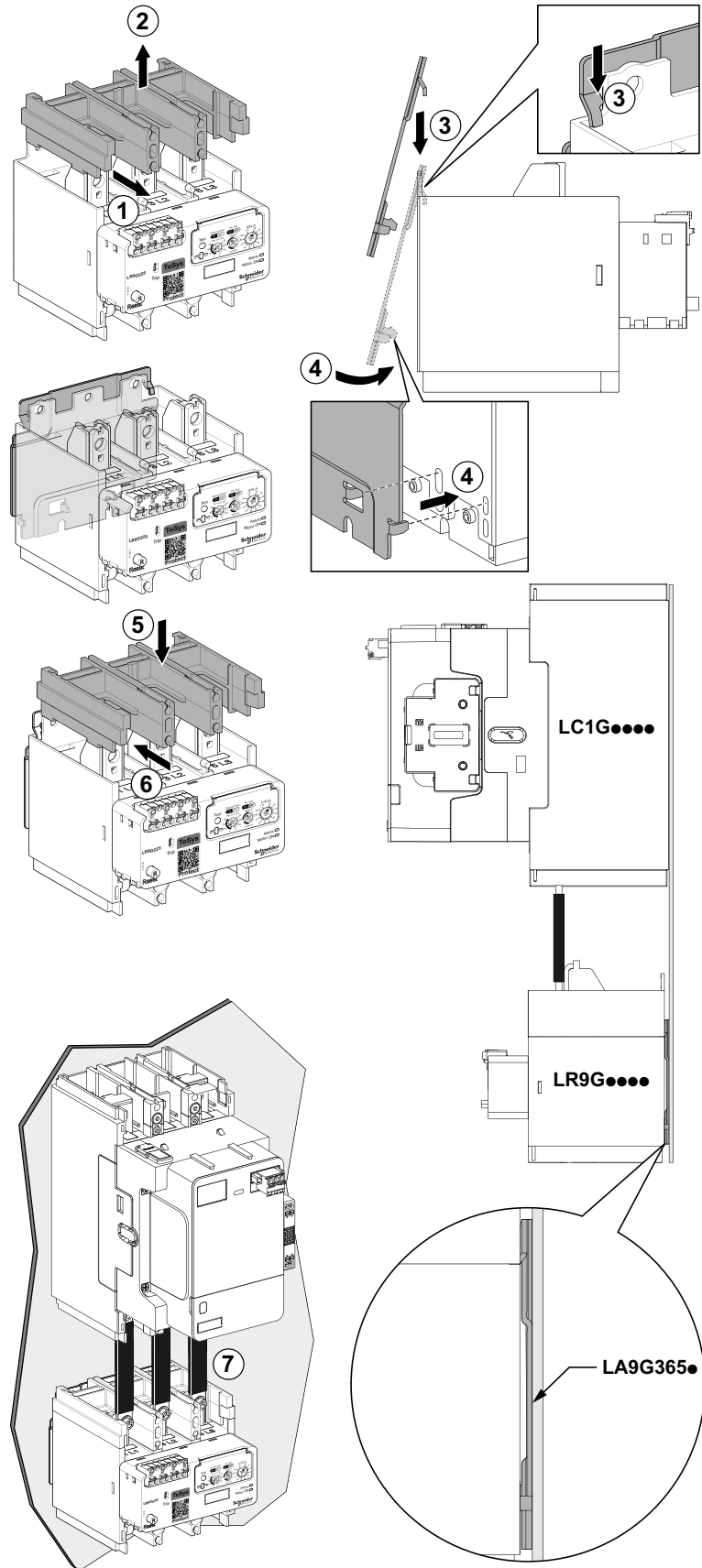

## Identification with Clip-On Marker Holder

There is a clip-on marker holder on the front face of each contactor and overload relay. The dimension of the marker holder is 8 x 18 mm (0.31 x 0.70 in.).

**NOTE:** Spare marker holder can be ordered with the commercial reference LA7D903 (set of 100 marker holders).

Perform the following procedure to identify an equipment with a marker holder.

1. Unclip and remove the marker holder from contactor or overload relay.
2. Write the identification code of the contactor or overload relay on the marker holder.
3. Clip the marker holder back on contactor or overload relay.

# Wiring

## What's in This Chapter

Wiring Precautions .....	96
Power Connections .....	97
Power Connection Accessories .....	103
Control Connections .....	121

## Wiring Precautions

Read and understand the following precautions before wiring the devices.

### **DANGER**

#### **HAZARD OF ELECTRIC SHOCK, EXPLOSION, OR ARC FLASH**

- Apply appropriate personal protective equipment (PPE) and follow safe electrical work practices. See NFPA 70E, CSA Z462, NOM 029-STPS or local equivalent.
- This equipment must only be installed and serviced by qualified electrical personnel.
- Turn off all power supplying this equipment before working on this equipment.
- Use only the specified voltage when operating this equipment and any associated products.
- Power line circuits must be wired and protected in compliance with local and national regulatory requirements.
- Beware of potential hazards, and carefully inspect the work area for tools and objects that may have been left inside the equipment.

**Failure to follow these instructions will result in death or serious injury.**

### **WARNING**

#### **FIRE HAZARD**

- Use only specified wiring cross-section with the equipment and comply with the specified wiring requirements.
- Tighten the connections to the specified torque values.

**Failure to follow these instructions can result in death, serious injury, or equipment damage.**

### **WARNING**

#### **UNINTENDED EQUIPMENT OPERATION**

Always route low level control wiring and power wiring separately.

**Failure to follow these instructions can result in death, serious injury, or equipment damage.**

# Power Connections

## Connection with Bars

### Overview

Bars can be used to connect contactors and overload relays. These are provided by the installer. The bars can be installed both upstream and downstream of contactors and overload relays.

Install a DC coupling bar kit both upstream and downstream of a DC contactor when connecting to the DC power circuit. For information, refer to DC coupling bar kit, page 124.

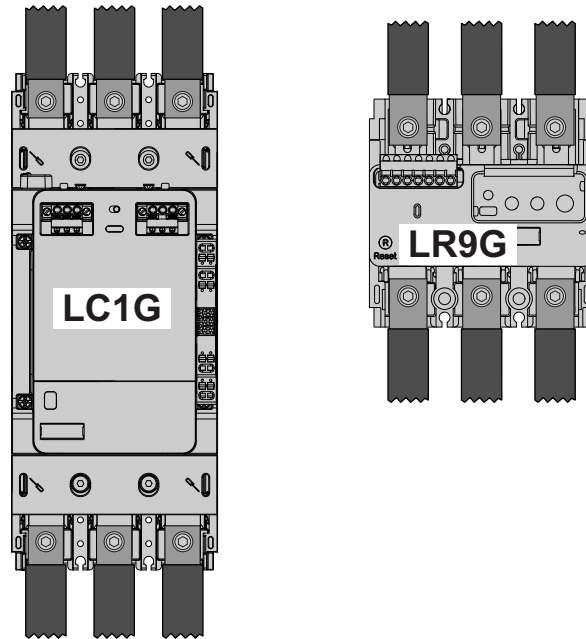

### Dimensions

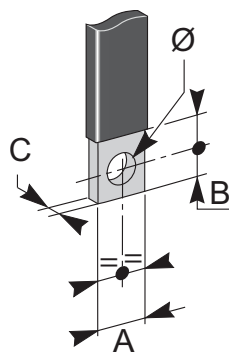

Contactor	Overload relay	A	B	C	Ø
LC1G115-225	LR9G115-225	≤ 25 mm (≤ 0.98 in.)	≤ 10 mm (≤ 0.39 in.)	≤ 6 mm (≤ 0.24 in.)	9 mm (0.35 in.)
LC1G265-500	LR9G500	≤ 32 mm (≤ 1.26 in.)	≤ 15 mm (≤ 0.59 in.)	3 mm ≤...≤ 10 mm (0.12 in. ≤...≤ 0.39 in.)	10.6 mm (0.41 in.)
LC1G630-800	LR9G630	≤ 50 mm (≤ 1.96 in.)	≤ 15 mm (≤ 0.59 in.)	3 mm ≤...≤ 10 mm (0.12 in. ≤...≤ 0.39 in.)	13 mm (0.51 in.)
LC1G250DC	–	≤ 25 mm (≤ 0.98 in.)	≤ 10 mm (≤ 0.39 in.)	≤ 6 mm (≤ 0.24 in.)	9 mm (0.35 in.)

## Bar Installation

Perform the following procedure to install the bars on the power terminals of the contactor or overload relay.

1. Place the bars on the power terminals of the contactor or overload relay.
2. Insert the screws through the bars and the power terminals and tighten the screws at the right torque.

Contactor	Overload Relay	Type of screws	Torque
LC1G115-225	LR9G115-225	Allen key	18±1.8 N•m (159±15.9 lb-in)
LC1G265-500	LR9G500	Inner hexagon	35±3.5 N•m (310±31 lb-in)
LC1G630-800	LR9G630	Inner hexagon	58±5.8 N•m (513±51.3 lb-in)
LC1G250DC	–	Allen key	18±1.8 N•m (159±15.9 lb-in)

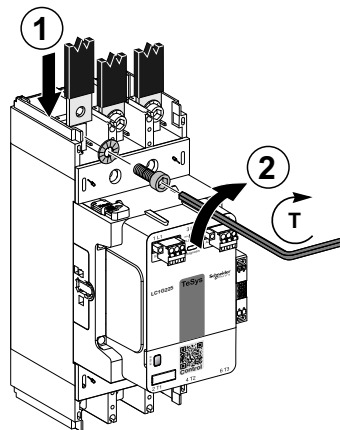

**NOTE:** You can also install two bars for the power connections.

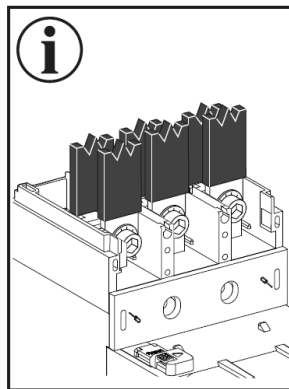

## Connection with Lugs

### Overview

Lugs can be used to connect contactors and overload relays:

- IEC lugs
- Third party lugs

The lugs can be installed both upstream and downstream of contactors and overload relays.

Install a DC coupling bar kit both upstream and downstream of a DC contactor when connecting to the DC power circuit. For information, refer to DC coupling bar kit, page 124.

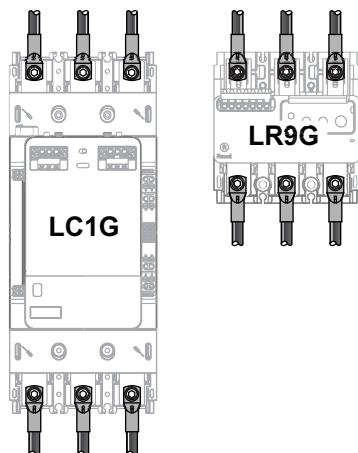

### IEC Lugs

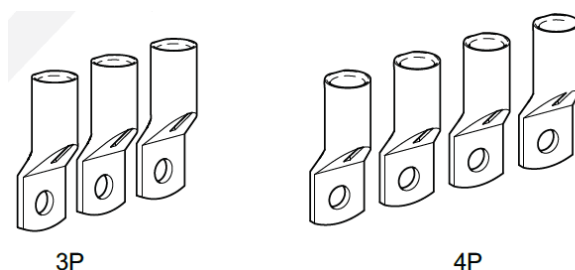

The table below provides the list of the IEC lugs used with the contactors and overload relays:

Contactors	Overload relay	Number of poles	IEC lugs	Cable section
LC1G115–225	LR9G115-225	3P	LV429252	120 mm <sup>2</sup> (4/0 AWG)
LC1G115–225	-	4P	LV429256	
LC1G115–225	LR9G115-225	3P	LV429253	150 mm <sup>2</sup> (4/0 AWG)
LC1G115–225	-	4P	LV429257	
LC1G115–225	LR9G115-225	3P	LV429254	185 mm <sup>2</sup> (5/0 AWG)
LC1G115–225	-	4P	LV429258	
LC1G265–500	LR9G500	3P	LV432500	240 mm <sup>2</sup> (6/0 AWG)
LC1G265–500	-	4P	LV432501	
LC1G265–500	LR9G500	3P	LV432502	300 mm <sup>2</sup> (7/0 AWG)
LC1G265–500	-	4P	LV432503	
LC1G250DC	-	3P	LV429254	185 mm <sup>2</sup> (5/0 AWG)

## Third Party Lugs

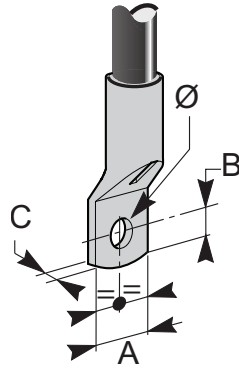

Contactor	Overload relay	A	B	C	Ø
LC1G115-225	LR9G115-225	≤ 25 mm (≤ 0.98 in.)	≤ 10 mm (≤ 0.39 in.)	≤ 6 mm (≤ 0.24 in.)	9 mm (0.35 in.)
LC1G265-500	LR9G500	≤ 32 mm (≤ 1.26 in.)	≤ 15 mm (≤ 0.59 in.)	3 mm ≤ ... ≤ 10 mm (0.12 in. ≤ ... ≤ 0.39 in.)	10.6 mm (0.41 in.)
LC1G630-800	LR9G630	≤ 50 mm (≤ 1.96 in.)	≤ 15 mm (≤ 0.59 in.)	3 mm ≤ ... ≤ 10 mm (0.12 in. ≤ ... ≤ 0.39 in.)	13 mm (0.51 in.)
LC1G250DC	–	≤ 25 mm (≤ 0.98 in.)	≤ 10 mm (≤ 0.39 in.)	≤ 6 mm (≤ 0.24 in.)	9 mm (0.35 in.)

## Lug Installation

Perform the following procedure to install the lugs on the power terminals of the contactor or overload relay.

1. Insert the washer and the screw through the lug hole.
2. Place the lugs on the power terminals of the contactor or overload relay.

## 3. Insert and tighten the screws at the right torque.

Contactor	Overload relay	Type of screws	Torque
LC1G115-225	LR9G115-225	Allen key	18±1.8 N•m (159±15.9 lb-in)
LC1G265-500	LR9G500	Inner hexagon	35±3.5 N•m (310±31 lb-in)
LC1G630-800	LR9G630	Inner hexagon	58±5.8 N•m (513±51.3 lb-in)
LC1G250DC	–	Allen key	18±1.8 N•m (159±15.9 lb-in)

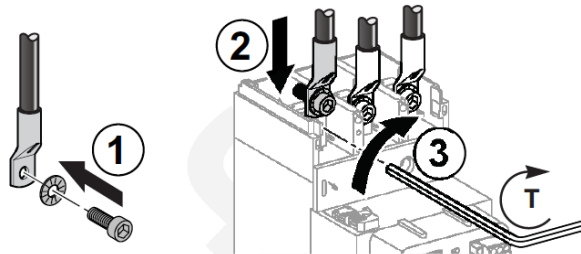

**NOTE:** Two lugs for the power connections can also be installed.

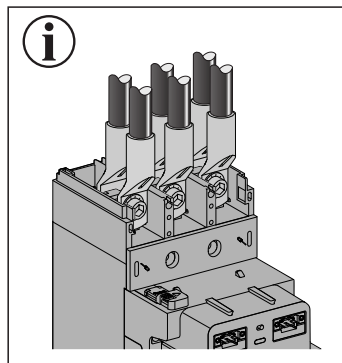

## Connection with Box Connectors

Box connectors can be used to connect contactors and overload relays fitted with the following terminal extensions:

- straight terminal extensions
- spreaders
- terminal adapters for box connectors.

The table below provides the list of the box connectors used with the contactors and overload relays:

Contactor	Overload relay	Terminal extension	Box connector
LC1G115-225	LR9G115-225	Straight terminal extensions LA9G●601	AL250●●●
			DZ2FG●●●
		Spreaders LA9G●611	AL250●●●
			DZ2FG●●●
			DZ2FH●●●
		Terminal adapters for box connectors LA9G●711	AL400●●●
			DZ2FH●●●
			DZ2FJ●●●
LC1G265-500	LR9G500	Spreaders LA9G●612	AL400●●●
			AL600LS52K●
			DZ2FJ●●●
			DZ2FK●●●
		Terminal adapters for box connectors LA9G●712	AL400●●●
			AL600LS52K●
			DZ2FJ●●●
			DZ2FK●●●
LC1G630-800	LR9G630	Terminal adapters for box connectors LA9G●714	AL600●●●
			DZ2FK●●●
			DZ2FL●●●
			Type S

## Power Connection Accessories

The contactors can be connected by using the below power connection accessories:

- Straight terminal extensions
- Edgewise terminal extensions
- L side terminal extensions 3P
- L large terminal extensions 3P
- L rear terminal extensions 3P
- Spreaders
- Large spreaders
- Flexible terminal extensions
- Terminal adapters for box connector

## Straight Terminal Extensions

### Overview

The straight terminal extensions are used to extend the connexion possibilities of the contactor.

The terminal extensions are screwed on the contactor using the screws delivered with the contactor.

The screws delivered with the terminal extensions are used to screw bars or lugs on the terminal extensions.

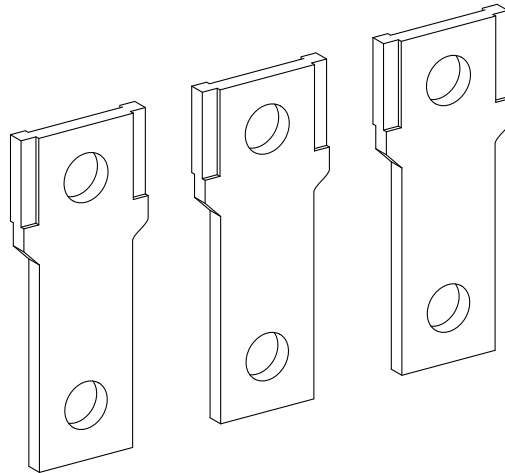

The table below provides the list of the straight terminal extensions:

Contactor	Number of poles	Straight terminal extension
LC1G115-225	3P	LA9G3601
	4P	LA9G4601
LC1G265-500	3P	LA9G3602
	4P	LA9G4602
LC1G630-800	3P	LA9G3603
	4P	LA9G4603

Box connectors can be installed on straight terminal extensions LA9G●601 for LC1G115-225 contactors.

## Dimension

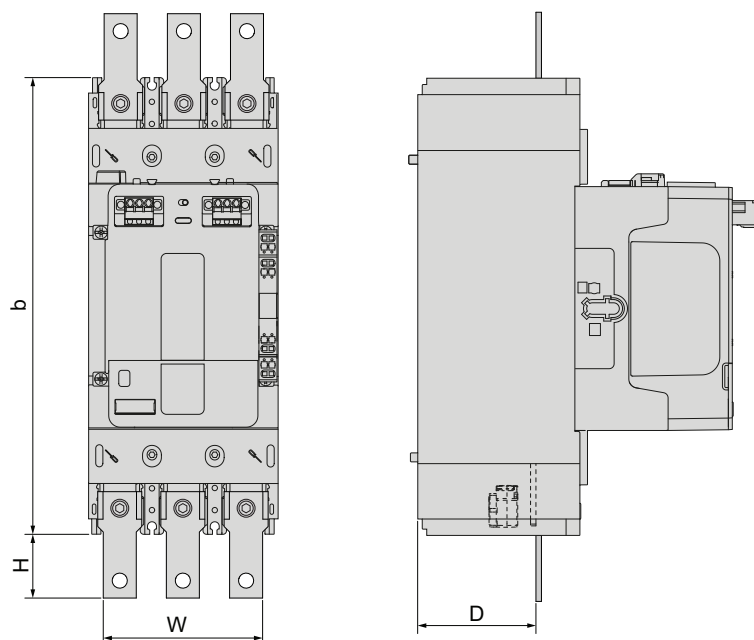

Contactor	Number of poles	W	H	D
LC1G115-225	3P	88 mm ( 3.46 in.)	34.5 mm ( 1.35 in.)	69.5 mm ( 2.73 in.)
	4P	123 mm (4.84 in.)	34.5 mm ( 1.35 in.)	69.5 mm ( 2.73 in.)
LC1G265-500	3P	120 mm ( 4.72 in.)	36 mm ( 1.41 in.)	84 mm ( 3.30 in.)
	4P	165 mm ( 6.49 in.)	36 mm ( 1.41 in.)	84 mm ( 3.30 in.)
LC1G630-800	3P	188 mm ( 7.40 in.)	49.7 mm ( 1.95 in.)	113 mm ( 4.44 in.)
	4P	258 mm ( 10.15 in.)	49.7 mm ( 1.95 in.)	113 mm ( 4.44 in.)

For installation instructions of power connection accessories, see Installation of the Power Connection Accessories, page 119

## Edgewise Terminal Extensions

### Overview

The edgewise terminal extensions are used to extend the connexion possibilities of the contactor.

The terminal extensions are screwed on the contactor using the screws delivered with the contactor.

The screws delivered with the terminal extensions are used to screw bars or lugs on the terminal extensions.

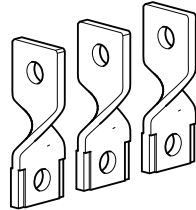

**3P**

The table below provides the list of the edgewise terminal extensions:

Contactor	Number of poles	Edgewise terminal extensions
LC1G115-225	3P	LA9G3631
	4P	LA9G4631
LC1G265-500	3P	LA9G3632
	4P	LA9G4632
LC1G630-800	3P	LA9G3633
	4P	LA9G4633

## Dimension

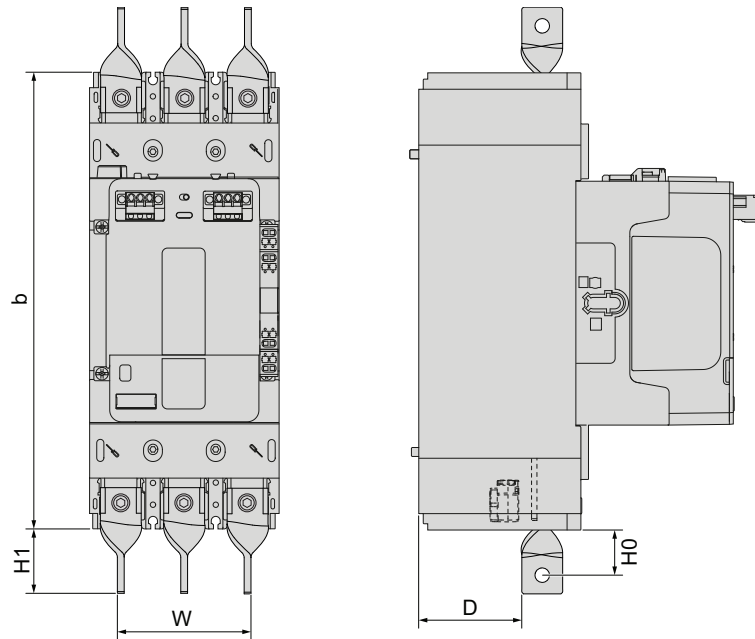

Contactor	Number of poles	W	H0	H1	D
LC1G115-225	3P	94 mm ( 3.70 in.)	27.5 mm ( 1.08 in.)	38.5 mm ( 1.51 in.)	59.5 mm ( 2.34 in.)
	4P	129 mm ( 5.07 in.)	27.5 mm ( 1.08 in.)	38.5 mm ( 1.51 in.)	59.5 mm ( 2.34 in.)
LC1G265-500	3P	120 mm ( 4.72 in.)	64.5 mm ( 2.53 in.)	78.5 mm ( 3.09 in.)	70 mm ( 2.75 in.)
	4P	165 mm ( 6.79 in.)	64.5 mm ( 2.53 in.)	78.5 mm ( 3.09 in.)	70 mm ( 2.75 in.)
LC1G630-800	3P	148 mm ( 5.82 in.)	93 mm ( 3.66 in.)	111 mm ( 4.37 in.)	93 mm ( 3.66 in.)
	4P	218 mm ( 8.58 in.)	93 mm ( 3.66 in.)	111 mm ( 4.37 in.)	93 mm ( 3.66 in.)

For installation instructions of power connection accessories, see Installation of the Power Connection Accessories, page 119.

## L Side Terminal Extensions

### Overview

The L side terminal extensions are used to extend the connection possibilities of 3-pole contactors.

The terminal extensions are screwed on the contactor using the screws delivered with the contactor.

The screws delivered with the terminal extensions are used to screw bars or lugs on the terminal extensions.

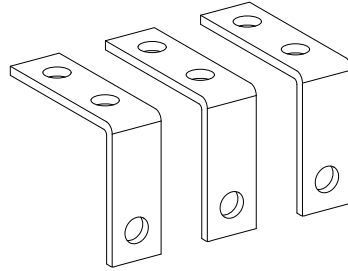

The table below provides the list of L side terminal extensions:

3-pole Contactor	L side terminal extensions
LC1G115-225	LA9G3661
LC1G265-500	LA9G3662
LC1G630-800	LA9G3663

### Dimension

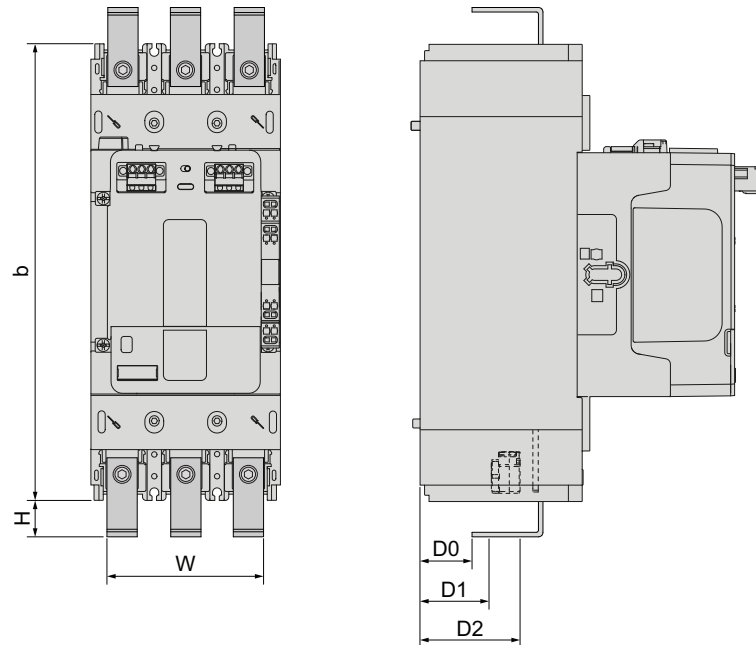

Contactor	Number of poles	W	H	D0	D1	D2
LC1G115-225	3P	88 mm (3.46 in.)	22.5 mm (0.88 in.)	17.5 mm (0.68 in.)	29.5 mm (1.16 in.)	55.5 mm (2.18 in.)
LC1G265-500	3P	120 mm (4.72 in.)	26.5 mm (1.04 in.)	17 mm (0.66 in.)	31 mm (1.22 in.)	63 mm (2.48 in.)
LC1G630-800	3P	188 mm (7.40 in.)	34 mm (1.33 in.)	42 mm (1.65 in.)	60 mm (2.36 in.)	96 mm (3.77 in.)

For installation instructions of power connection accessories, see Installation of the Power Connection Accessories, page 119.

## L Large Terminal Extension

### Overview

The L large terminal extensions are used to extend the connection possibilities of 3-pole contactors.

The terminal extensions are screwed on the contactor using the screws delivered with the contactor.

The screws delivered with the terminal extensions are used to screw bars or lugs on the terminal extensions.

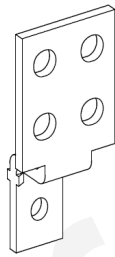

The table below provides the list of L large terminal extensions:

3-pole Contactor	L large terminal extensions
LC1G115-225	LA9G3671
LC1G265-500	LA9G3672
LC1G630-800	LA9G3673

### Dimension

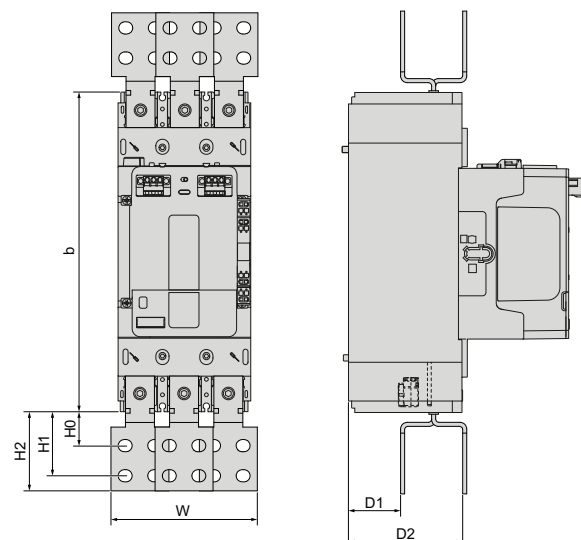

Contactor	Number of poles	W	H0	H1	H2	D1	D2
LC1G115-225	3P	110 mm (4.33 in.)	28.5 mm (1.12 in.)	50.5 mm (1.98 in.)	60.5 mm (2.38 in.)	46.5 mm (3.46 in.)	92.5 mm (3.64 in.)
LC1G265-500	3P	150 mm (5.90 in.)	38.5 mm (1.51 in.)	68.5 mm (2.69 in.)	84.5 mm (3.46 in.)	55 mm (3.32 in.)	111 mm (4.37 in.)
LC1G630-800	3P	240 mm (9.44 in.)	55 mm (2.16 in.)	90 mm (3.54 in.)	113 mm (3.46 in.)	80 mm (3.14 in.)	146 mm (5.74 in.)

For installation instructions of power connection accessories, see Installation of the Power Connection Accessories, page 119.

## L Rear Terminal Extension

### Overview

The L side terminal extensions are used to extend the connection possibilities of 3-pole contactors.

The terminal extensions are screwed on the contactor using the screws delivered with the contactor.

The screws delivered with the terminal extensions are used to screw bars or lugs on the terminal extensions.

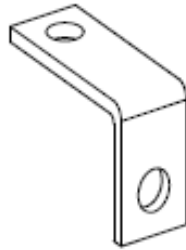

The table below provides the list of L rear terminal extensions:

3-pole Contactor	L rear terminal extensions 3P
LC1G115-225	LA9G3681
LC1G265-500	LA9G3682
LC1G630-800	LA9G3683

### Dimension

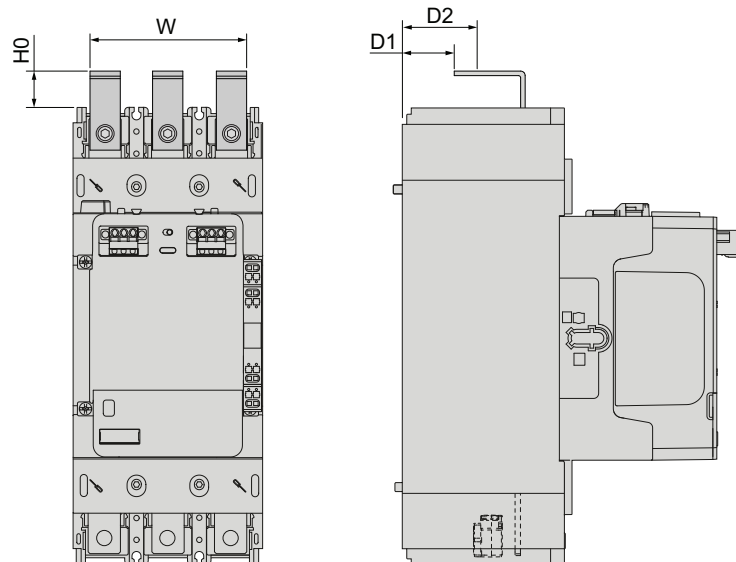

Contactor	Number of poles	W	H0	D1	D2
LC1G115-225	3P	88 mm (3.46 in.)	22.5 mm (0.88 in.)	44.5 mm (1.75 in.)	53.5 mm (2.10 in.)
LC1G265-500	3P	150 mm (5.90 in.)	38.5 mm (1.51 in.)	68.5 mm (2.69 in.)	84.5 mm (3.32 in.)
LC1G630-800	3P	188 mm (7.40 in.)	34 mm (1.33 in.)	73 mm (2.87 in.)	91 mm (3.58 in.)

For installation instructions of power connection accessories, see [Installation of the Power Connection Accessories](#), page 119.

# Spreaders

## Overview

The spreaders are used on contactors:

- to increase the pole pitch of the contactor and align the contactor poles with circuit breaker poles or
- to increase the clearance distance between phases or
- to connect larger bars or lugs.

The spreaders are screwed on the contactor using the screws delivered with the contactor.

The screws delivered with the spreaders are used to screw bars or lugs on the spreaders.

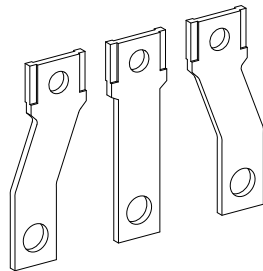

The table below provides the list of spreaders used with contactors:

Contactor	Number of poles	Spreaders
LC1G115-225	3P	LA9G3611
	4P	LA9G4611
LC1G265-500	3P	LA9G3612
	4P	LA9G4612

Box connectors can be installed on spreaders.

## Dimension

Box connectors can be installed on spreaders.

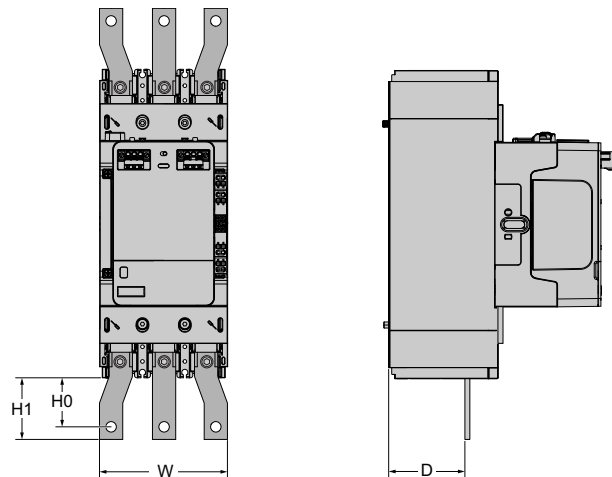

Contactor	Number of poles	W	H0	H1	D
LC1G115-225	3P	108 mm (4.25 in.)	44 mm (1.75 in.)	54.5 mm (2.15 in.)	69.5 mm (2.73 in.)
	4P	153 mm (6.02 in.)	44 mm (1.75 in.)	54.5 mm (2.15 in.)	69.5 mm (2.73 in.)
LC1G265-500	3P	170 mm (6.70 in.)	61 mm (2.40 in.)	73 mm (2.87 in.)	84 mm (3.30 in.)

Contactor	Number of poles	W	H0	H1	D
	4P	240 mm (9.45 in.)	71 mm (2.80 in.)	83 mm (3.26 in.)	84 mm (3.30 in.)

For installation instructions of power connection accessories, see Installation of the Power Connection Accessories, page 119.

## Large Spreaders

### Overview

The large spreaders are used on LC1G400–800 contactors to connect larger bars. They are delivered with phase separators.

The large spreaders are screwed on the contactor using the screws delivered with the contactor.

The screws delivered with the large spreaders are used to screw bars or lugs on the large spreaders.

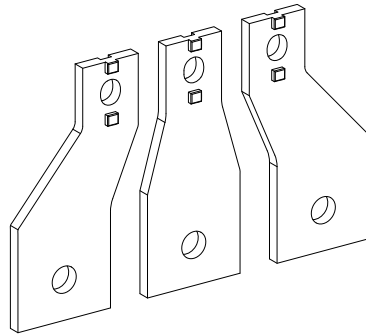

The table below provides the list of large spreaders used with contactors:

Contactor	Number of poles	Spreaders
LC1G400–500	3P	LA9G3613
	4P	LA9G4613
LC1G630–800	3P	LA9G3614
	4P	LA9G4614

### Dimension

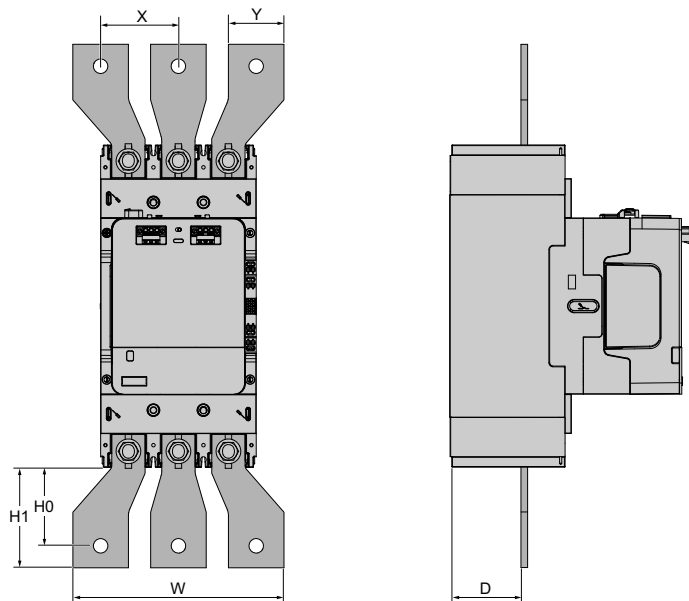

Contactor	Number of poles	X	Y	W	H0	H1	D
LC1G400–500	3P	70 mm (2.75 in.)	55 mm (2.16 in.)	190 mm (7.48 in.)	71 mm (2.79 in.)	91 mm (3.58 in.)	84 mm (3.30 in.)
	4P	70 mm (2.75 in.)	55 mm (2.16 in.)	260 mm (10.23 in.)	71 mm (2.79 in.)	91 mm (3.58 in.)	84 mm (3.30 in.)

Contactor	Number of poles	X	Y	W	H0	H1	D
LC1G630-800	3P	95 mm (3.74 in.)	80 mm (3.15 in.)	270 mm (10.62 in.)	75 mm (2.95 in.)	90 mm (3.54 in.)	107 mm (4.21 in.)
	4P	95 mm (3.74 in.)	80 mm (3.15 in.)	365 mm (14.37 in.)	89.7 mm (3.53 in.)	100 mm (3.93 in.)	107 mm (4.21 in.)

For installation instructions of power connection accessories, see Installation of the Power Connection Accessories, page 119.

## Installation of Phase Separators

1. Place the phase separator on the power terminals of the contactor.
2. Push the phase separator inwards to lock it automatically with a click.

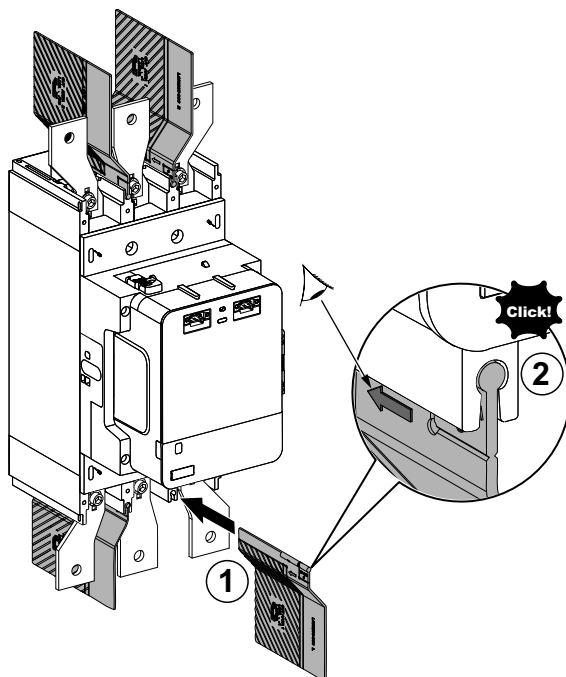

## Flexible Terminal Extensions

Flexible connecting bars can be used to connect TeSys Giga advanced or standard contactors with moulded case circuit breakers mounted in the same plane and orientation.

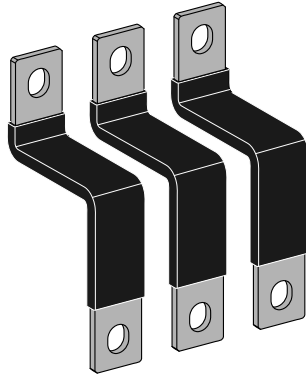

The table below provides the list of flexible terminal extensions used to connect advanced or standard contactors with moulded case circuit breakers:

Contactor	Moulded case circuit breaker	Number of poles	Flexible terminal extensions
LC1G115-225	TeSys Power – Giga Motor Protection Frame 5	3P	LA9G3111
	ComPacT NSX100-250		
	PowerPacT H- / J-Frame		
	ComPacT NSX100-250	4P	LA9G4111
LC1G265-500	TeSys Power – Giga Motor Protection Frame 6	3P	LA9G3112
	ComPacT NSX400-630		
	PowerPacT L-Frame		
	ComPacT NSX400-630	4P	LA9G4112
LC1G630-800	ComPacT NS630b-1600	3P	LA9G3113
	PowerPacT P-Frame		
	ComPacT NS630b-1600	4P	LA9G4113

**NOTE:** To ease the mounting, drilling stencils JYT1902701 can be downloaded from the [www.se.com](http://www.se.com) website.

# Terminal Adapters for Box Connector

## Overview

Terminal adapters for box connectors are used on contactors to connect box connectors.

The terminal adapters are screwed on the contactor using the screws delivered with the contactor.

The screws delivered with the terminal adapters are used to screw box connectors on the terminal adapters.

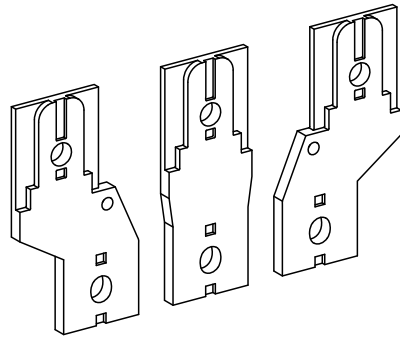

The table below provides the list of the terminal adapters used with contactors:

Contactor	Number of poles	Terminal adapters for box connection
LC1G115-225	3P	LA9G3711
	4P	LA9G4711
LC1G265-500	3P	LA9G3712
	4P	LA9G4712
LC1G630-800	3P	LA9G3714
	4P	LA9G4714

## Dimension

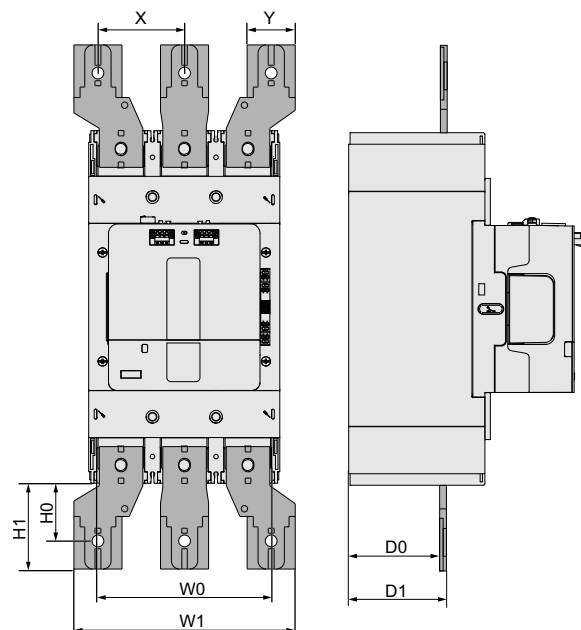

Advanced contactor	Number of poles	X	Y	W0	W1	H0	H1	D0	D1
LC1G115-225	3P	52.5 mm (2.07 in.)	35 mm (1.38 in.)	94 mm (3.7 in.)	140 mm (5.51 in.)	44.3 mm (1.74 in.)	56.5 mm (2.22 in.)	67 mm (2.64 in.)	70 mm (2.75 in.)
	4P	52.5 mm (2.07 in.)	35 mm (1.38 in.)	159 mm (6.26 in.)	192.5 mm (7.58 in.)	52.5 mm (2.07 in.)	64.5 mm (2.54 in.)	67 mm (2.64 in.)	70 mm (2.75 in.)
LC1G265-330	3P	70 mm (2.75 in.)	29.4 mm (1.16 in.)	120 mm (4.72 in.)	169.4 mm (6.67 in.)	43.25 mm (1.7 in.)	55.75 mm (2.19 in.)	79 mm (3.11 in.)	85 mm (3.35 in.)
	4P	70 mm (2.75 in.)	29.4 mm (1.16 in.)	120 mm (4.72 in.)	214.4 mm (8.44 in.)	43.25 mm (1.7 in.)	55.75 mm (2.19 in.)	79 mm (3.11 in.)	85 mm (3.35 in.)
LC1G400	3P	70 mm (2.75 in.)	29.4 mm (1.16 in.)	120 mm (4.72 in.)	169.4 mm (6.67 in.)	43.25 mm (1.7 in.)	55.75 mm (2.19 in.)	79 mm (3.11 in.)	85 mm (3.35 in.)
	4P	70 mm (2.75 in.)	29.4 mm (1.16 in.)	165 mm (6.5 in.)	214.4 mm (8.44 in.)	43.25 mm (1.7 in.)	55.75 mm (2.19 in.)	79 mm (3.11 in.)	85 mm (3.35 in.)
LC1G500	3P	70 mm (2.75 in.)	29.4 mm (1.16 in.)	165 mm (6.5 in.)	169.4 mm (6.67 in.)	43.25 mm (1.7 in.)	55.75 mm (2.19 in.)	79 mm (3.11 in.)	85 mm (3.35 in.)
	4P	70 mm (2.75 in.)	29.4 mm (1.16 in.)	165 mm (6.5 in.)	214.4 mm (8.44 in.)	43.25 mm (1.7 in.)	55.75 mm (2.19 in.)	79 mm (3.11 in.)	85 mm (3.35 in.)
LC1G630-800	3P	95.5 mm (3.76 in.)	29 mm (1.14 in.)	188 mm (7.4 in.)	244 mm (9.6 in.)	67.9 mm (2.67 in.)	94.71 mm (3.73 in.)	107 mm (4.21 in.)	115 mm (4.53 in.)
	4P	87 mm (3.42 in.)	29 mm (1.14 in.)	258 mm (10.16 in.)	314 mm (12.36 in.)	67.9 mm (2.67 in.)	94.71 mm (3.73 in.)	107 mm (4.21 in.)	115 mm (4.53 in.)

Standard contactor	Number of poles	X	Y	W0	W1	H0	H1	D0	D1
LC1G115-225	3P	52.5 mm (2.07 in.)	35 mm (1.38 in.)	88 mm (3.46 in.)	140 mm (5.51 in.)	44.3 mm (1.74 in.)	56.5 mm (2.22 in.)	70 mm (2.75 in.)	73 mm (2.87 in.)
	4P	52.5 mm (2.07 in.)	35 mm (1.38 in.)	123 mm (4.84 in.)	192.5 mm (7.58 in.)	52.5 mm (2.07 in.)	64.5 mm (2.54 in.)	70 mm (2.75 in.)	73 mm (2.87 in.)
LC1G265-330	3P	70 mm (2.75 in.)	29.4 mm (1.16 in.)	120 mm (4.72 in.)	169.4 mm (6.67 in.)	43.25 mm (1.7 in.)	55.75 mm (2.19 in.)	82 mm (3.23 in.)	88 mm (3.46 in.)
	4P	70 mm (2.75 in.)	29.4 mm (1.16 in.)	165 mm (6.5 in.)	214.4 mm (8.44 in.)	43.25 mm (1.7 in.)	55.75 mm (2.19 in.)	83 mm (3.27 in.)	89 mm (3.5 in.)
LC1G400	3P	70 mm (2.75 in.)	29.4 mm (1.16 in.)	120 mm (4.72 in.)	169.4 mm (6.67 in.)	43.25 mm (1.7 in.)	55.75 mm (2.19 in.)	84 mm (3.3 in.)	90 mm (3.54 in.)
	4P	70 mm (2.75 in.)	29.4 mm (1.16 in.)	165 mm (6.5 in.)	214.4 mm (8.44 in.)	43.25 mm (1.7 in.)	55.75 mm (2.19 in.)	82 mm (3.23 in.)	88 mm (3.46 in.)
LC1G500	3P	70 mm (2.75 in.)	29.4 mm (1.16 in.)	120 mm (4.72 in.)	169.4 mm (6.67 in.)	43.25 mm (1.7 in.)	55.75 mm (2.19 in.)	83 mm (3.27 in.)	89 mm (3.5 in.)
	4P	70 mm (2.75 in.)	29.4 mm (1.16 in.)	165 mm (6.5 in.)	214.4 mm (8.44 in.)	43.25 mm (1.7 in.)	55.75 mm (2.19 in.)	84 mm (3.3 in.)	90 mm (3.54 in.)
LC1G630-800	3P	95.5 mm (3.76 in.)	29 mm (1.14 in.)	188 mm (7.4 in.)	244 mm (9.6 in.)	67.9 mm (2.67 in.)	94.71 mm (3.73 in.)	113 mm (4.45 in.)	121 mm (4.76 in.)
	4P	87 mm (3.42 in.)	29 mm (1.14 in.)	258 mm (10.16 in.)	314 mm (12.36 in.)	67.9 mm (2.67 in.)	94.71 mm (3.73 in.)	113 mm (4.45 in.)	121 mm (4.76 in.)

For installation instructions of power connection accessories, see Installation of the Power Connection Accessories, page 119.

## Installation of the Power Connection Accessories

This section describes the installation procedure of straight terminal extensions on the power terminals. The installation procedure is the same for all other power connection accessories.

1. Place the terminal extension on the power terminals.
2. Insert the screw and washer through the hole at the top of the terminal extension.
3. Tighten the screws at the right torque.

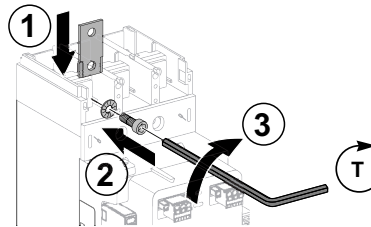

Contactor	Type of screws	Torque
LC1G115-225	Allen key	18±1.8 N•m (159±15.9 lb-in)
LC1G265-500	Inner hexagon	35±3.5 N•m (310±31 lb-in)
LC1G630-800	Inner hexagon	58±5.8 N•m (513±51.3 lb-in)

## Bar or Lug Connection

1. Place the bar or lug of the power circuit on the terminal extension.
2. Connect the terminal extensions to the power circuit using the screws delivered with the terminal extensions.
3. Tighten the screws at the right torque. The torques are the same as the torques to connect the terminal extensions on the contactor.

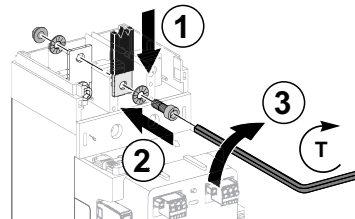

## Installation of the Box Connectors

Box connectors can be used to connect contactors and overload relays fitted with the following terminal extensions:





- straight terminal extensions
  - spreaders
  - terminal adapters for box connectors.
1. Place the box connector on the terminal extension.
  2. Insert the screw and washer through the box connector and hole at the top of the terminal extension.
  3. Tighten the screws at the right torque.
  4. Place the cable of the power circuit in the box connector.
  5. Tighten the box connector screws at the right torque.

For more information on box connector installation and connection, refer to the instruction bulletin supplied with the box connectors.

## Control Connections

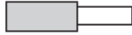
### Contactor Wiring Characteristics





The table below provides wiring characteristics of the push-in terminals blocks of advanced or standard contactors:

Cable type	Stripping length	Number of conductors		Section
Solid Cable	12 mm (0.47 in.)	1 conductor without cable end		0.2–2.5 mm <sup>2</sup> (26–14 AWG)
		2 conductors with suitable dual sleeve		0.5-1.0 mm <sup>2</sup> (20-18 AWG)
Flexible cable	12 mm (0.47 in.)	1 conductor with suitable cable end or sleeve	 	0.25-2.5 mm <sup>2</sup>
		2 conductors with suitable dual sleeve		0.5-1.0 mm <sup>2</sup> (20-18 AWG)
Do not use flexible cable without cable end or sleeve.				

For the contactor wiring diagrams, see Control Mode, page 25

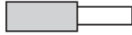
### Overload Relay Wiring Characteristics

The table below provides wiring characteristics of the push-in terminals blocks of overload relays:

Cable type	Stripping length	Number of conductors		Section
Solid Cable	10 mm (0.40 in.)	1 conductor without cable end		0.2–2.5 mm <sup>2</sup> (26–14 AWG)
		2 conductors with suitable dual sleeve		0.5-1.0 mm <sup>2</sup> (20-18 AWG)
Flexible cable	10 mm (0.40 in.)	1 conductor with suitable cable end or sleeve	 	0.2–2.5 mm <sup>2</sup> (26–14 AWG)
		2 conductors with suitable dual sleeve		0.5-1.0 mm <sup>2</sup> (20-18 AWG)
Do not use flexible cable without cable end or sleeve.				

For the overload relay wiring diagram, see Wiring Diagram, page 32.

## Conductor Connection

Insert the conductor in the push-in terminal to connect the conductor.

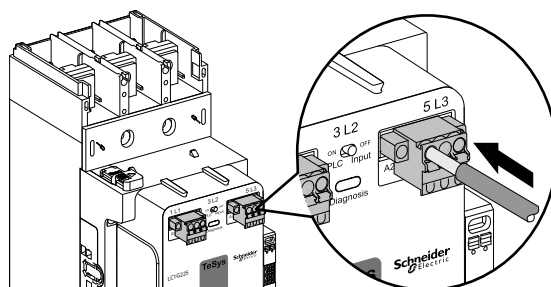

## Removing the Conductor from the Push-in Terminal

1. Push the button below the conductor with a screwdriver to loosen the connection of the conductor from the push-in terminal.
2. Pull the conductor out from the push-in terminal.

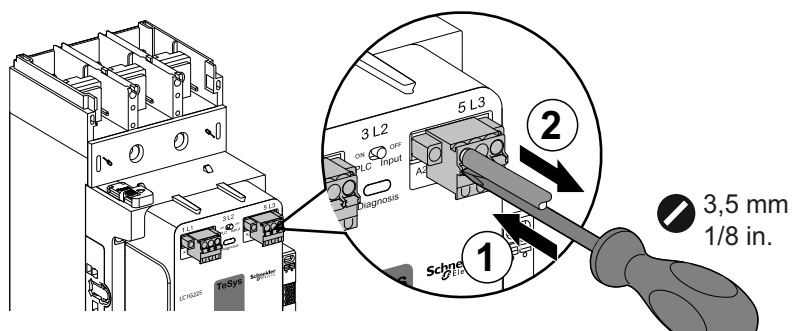

# Installation of Accessories

## What's in This Chapter

DC Coupling Bar .....	124
Insulation Accessories .....	126
Functional Accessories .....	138

# DC Coupling Bar

## Overview

DC coupling bar kit is used to couple the DC contactor windings.

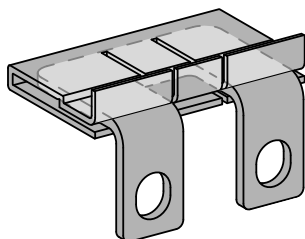

Contactor	Number of poles	DC coupling bar kit
LC1G250DC	3P	LA9GQU601

## Dimensions

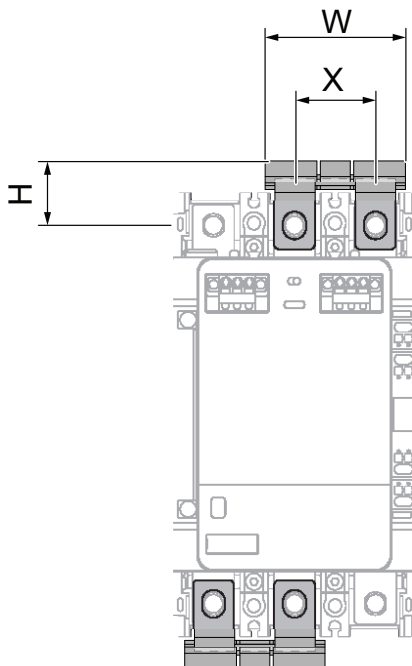

Contactor	Number of poles	W	X	H
LC1G250DC	3P	61 mm (2.40 in.)	34 mm (1.33 in.)	30.7 mm (1.2 in.)

## Power Wiring Diagram

2-pole in series

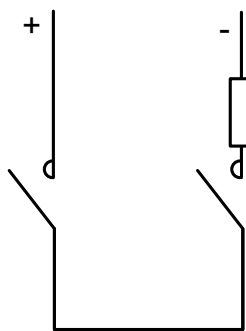

3-pole in series

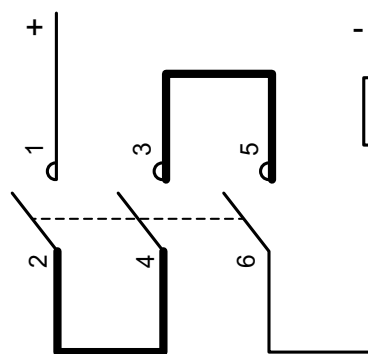

## Installation of DC Coupling Bar kit

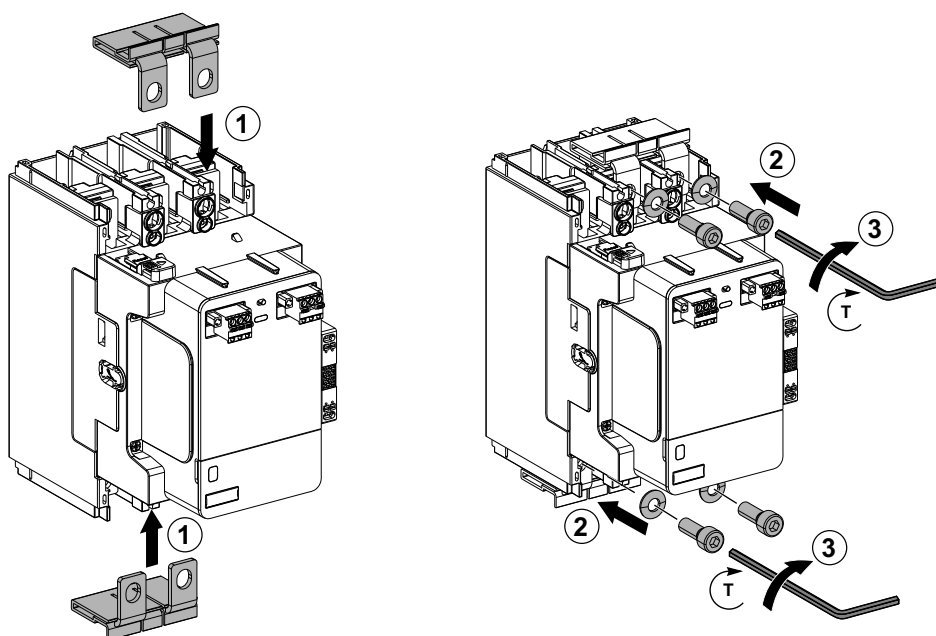

This section describes the installation procedure of DC coupling bar kits on the power terminals of DC contactors.

1. Place the coupling bar beside the power terminals of the contactor.
2. Insert the screws and washers through the coupling bars and power terminals.
3. Tighten the screws at the right torque.

## Insulation Accessories

### Terminal Shrouds

#### ⚠ WARNING

##### HAZARD OF FLASH OVER BETWEEN POLARITIES

Terminal shrouds must be installed if the network voltage is greater than or equal to 690 Vac.

**Failure to follow these instructions can result in death, serious injury, or equipment damage.**

### Overview

The terminal shrouds can be installed on the top and bottom of the power terminals of advanced and standard contactors and overload relays to provide IP20 protection. One terminal shroud is made up of two covers:

- Front cover
- Back cover.

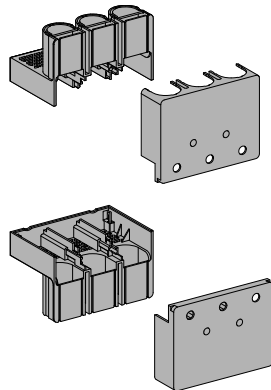

The terminal shrouds must be ordered separately. The table below provides the commercial references of the terminal shrouds. For each commercial reference, one terminal shroud is delivered, for installing either on top and bottom power terminals:

Contactor	Overload relay	Number of poles	Terminal shroud
LC1G115-225	LR9G115-225	3P	LA9G3701
LC1G115-225	-	4P	LA9G4701
LC1G265-500	LR9G500	3P	LA9G3702
LC1G265-500	-	4P	LA9G4702
LC1G630-800	LR9G630	3P	LA9G3703
LC1G630-800	-	4P	LA9G4703

**NOTE:** Either phase separators or terminal shrouds can only be mounted. Phase separators or terminal shrouds are mandatory for operational voltage,  $U_e \geq 690$  V.

## Compatibility

The terminal shrouds can be installed :

- on advanced and standard contactors
- on overload relays
- on top and bottom power connections connected with:
  - bars or lugs
  - coupling bars

**NOTE:** The terminal shrouds cannot be installed on contactors with power connection accessories and spreaders, or with phase separators.

## Overall Dimension

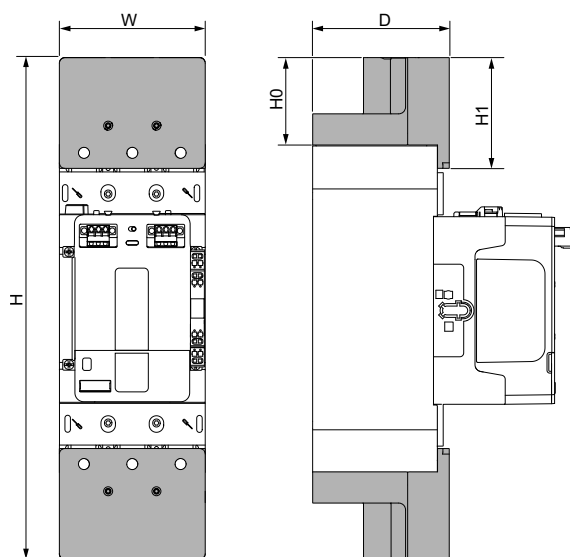

The table below provides the dimension detail and other technical characteristics of the terminal shroud:

Advanced contactor	Number of poles	W	D	H	H0	H1
LC1G115–225	3P	105.1 mm (4.13 in.)	98.5 mm (3.87 in.)	364 mm (14.33 in.)	63.5 mm (2.5 in.)	80.5 mm (3.16 in.)
	4P	140.7 mm (5.53 in.)	98.5 mm (3.87 in.)	364 mm (14.33 in.)	63.5 mm (2.5 in.)	80.5 mm (3.16 in.)
LC1G265–500	3P	140 mm (5.51 in.)	121.5 mm (4.78 in.)	424 mm (16.69 in.)	79.5 mm (3.12 in.)	96.5 mm (3.79 in.)
	4P	185 mm (7.28 in.)	121.5 mm (4.78 in.)	424 mm (16.69 in.)	79.5 mm (3.12 in.)	96.5 mm (3.79 in.)
LC1G630–800	3P	210.6 mm (8.29 in.)	163.5 mm (6.44 in.)	526.8 mm (20.74 in.)	81.75 mm (3.22 in.)	115 mm (4.53 in.)
	4P	280.6 mm (11.05 in.)	163.5 mm (6.44 in.)	526.8 mm (20.74 in.)	81.75 mm (3.22 in.)	115 mm (4.53 in.)

Standard contactor	Number of poles	W	D	H	H0	H1
LC1G115–225	3P	105.1 mm (4.13 in.)	98.5 mm (3.87 in.)	302 mm (11.88 in.)	63.5 mm (2.5 in.)	80.5 mm (3.16 in.)
	4P	140.7 mm (5.53 in.)	98.5 mm (3.87 in.)	302 mm (11.88 in.)	63.5 mm (2.5 in.)	80.5 mm (3.16 in.)
LC1G265–500	3P	140 mm (5.51 in.)	121.5 mm (4.78 in.)	359 mm (14.13 in.)	79.5 mm (3.12 in.)	96.5 mm (3.79 in.)

	4P	185 mm (7.28 in.)	121.5 mm (4.78 in.)	359 mm (14.13 in.)	79.5 mm (3.12 in.)	96.5 mm (3.79 in.)
LC1G630–800	3P	210.6 mm (8.29 in.)	163.5 mm (6.44 in.)	422.3 mm (16.63 in.)	81.75 mm (3.22 in.)	115 mm (4.53 in.)
	4P	280.6 mm (11.05 in.)	163.5 mm (6.44 in.)	422.3 mm (16.63 in.)	81.75 mm (3.22 in.)	115 mm (4.53 in.)

## Terminal Shroud Preparation

Prepare the terminal shrouds for installation by cutting the unnecessary parts on the front cover and the back cover with a tool. The following tables provide information about the preparation required before installation of the terminal shrouds according to the contactor rating.

**NOTE:** When the terminal shrouds are installed on contactor with coupling bars, only the front cover must be prepared. The back cover is not necessary.

### LC1G115-500 contactors

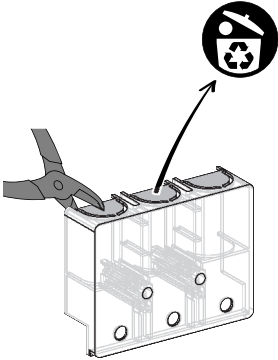
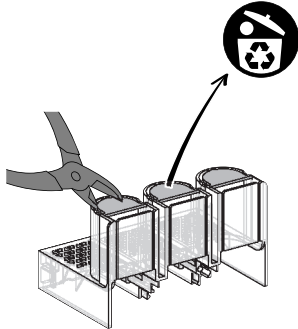
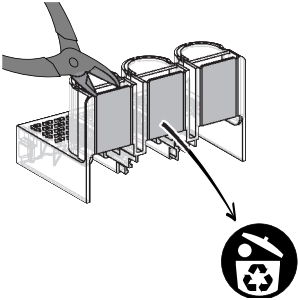
Power connection accessory	Front cover	Back cover
Bars	Nothing to cut	Nothing to cut.
Lugs	<p>If lugs are connected at the front of the contactor terminals, cut the part from top.</p> 	<p>If lugs are connected at the back of the contactor terminals, cut the part from bottom.</p> 
Contactor with cable memory connection blocks	Nothing to cut	<p>Cut the part from middle.</p> 

### LC1G630-800 contactors without cable memory

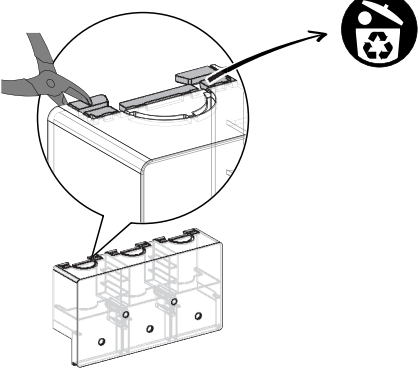
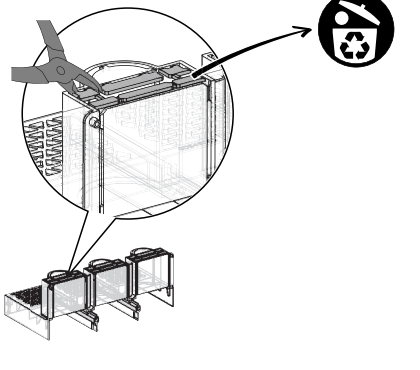
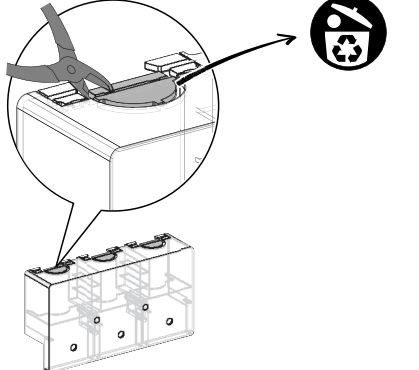
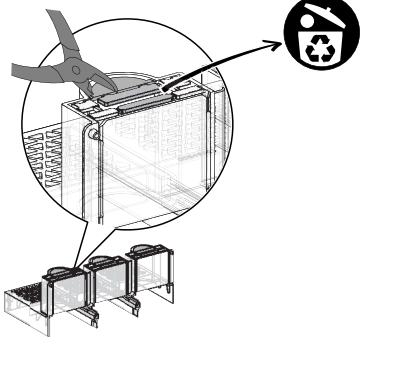
Power connection accessory	Front cover	Back cover
Bars	<p>If lugs are connected at the front of the contactor terminals, cut the part from top.</p> 	<p>If lugs are connected at the back of the contactor terminals, cut the part from bottom.</p> 
Lugs	<p>If lugs are connected at the front of the contactor terminals, cut the part from top.</p> 	<p>If lugs are connected at the back of the contactor terminals, cut the part from bottom.</p> 

### LC1G630-800 contactors with cable memory

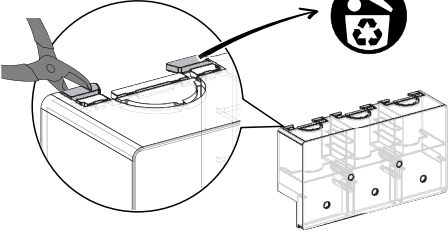
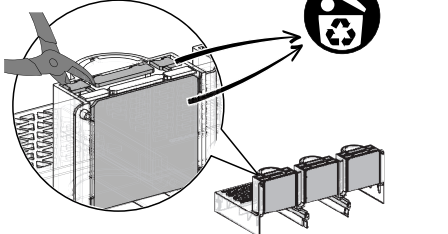
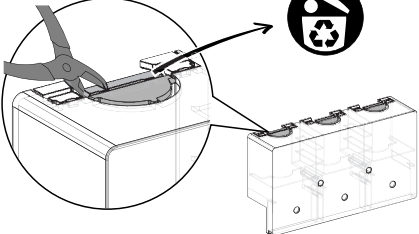
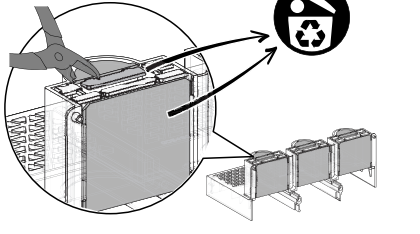
Power connection accessory	Front cover	Back cover
Bars		
Lugs		

## Installation of Terminal Shroud with Bars, Lugs or Terminal Extensions

1. Install the back cover of the terminal shroud on the contactor to lock it automatically with a click.
2. Place and insert the bars inwards through the back cover of the terminal shroud.
3. Place and insert the lugs on the power terminals of the contactor.
4. Insert and tighten the screws at the right torque.

Contactor	Type of screws	Torque
LC1G115-225	Allen key	18±1.8 N•m (159±15.9 lb-in)
LC1G265-500	Inner hexagon	35±3.5 N•m (310±31 lb-in)
LC1G630-800	Inner hexagon	58±5.8 N•m (513±51.3 lb-in)

5. Install the front cover of the terminal shroud.
6. Insert and tighten the screws at the right torque to lock the front cover.

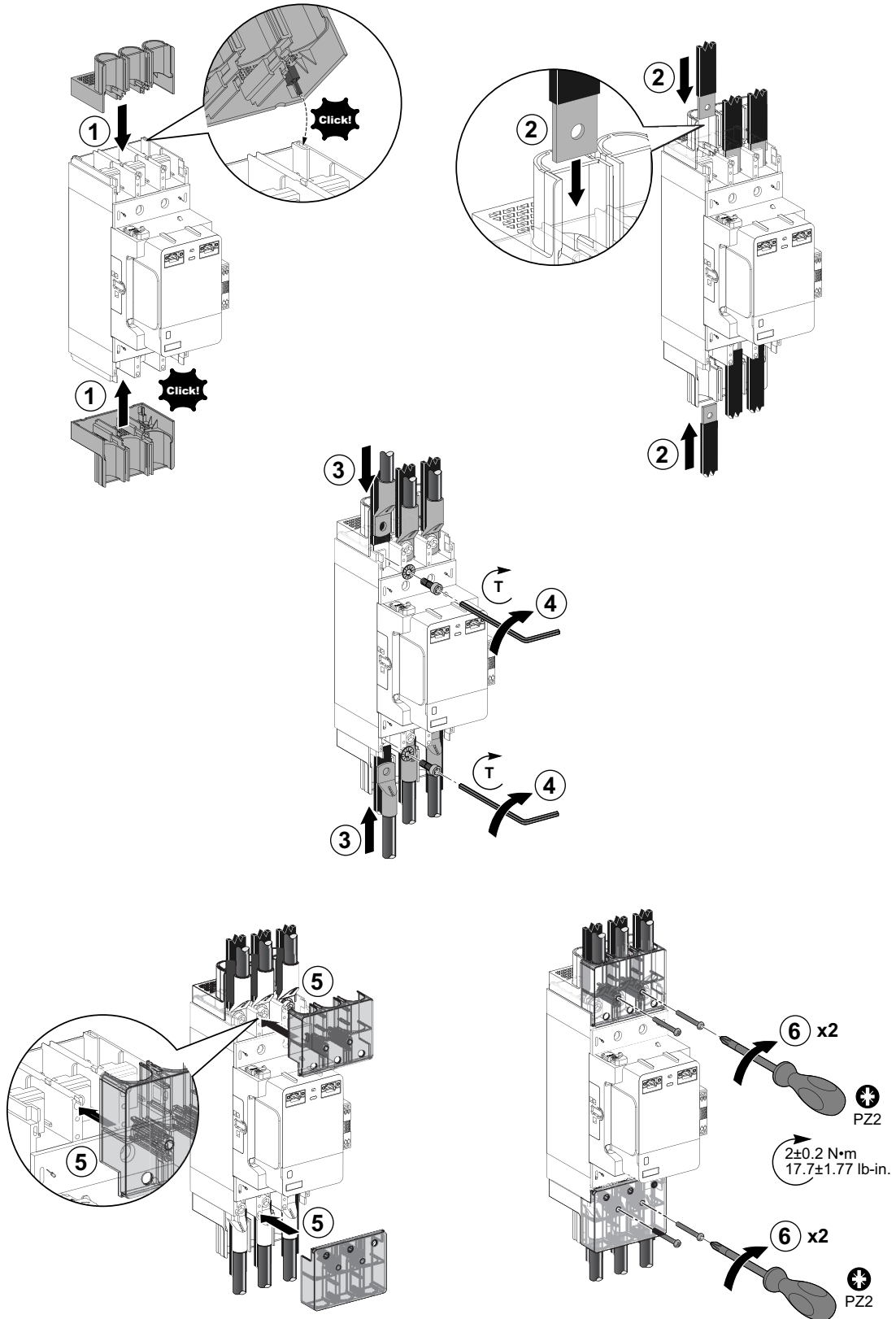

## Installation of Terminal Shroud with Coupling Bars

With coupling bars, the back cover of the terminal shroud cannot be installed. You can use optional lug covers LA9G3707 or LA9G4707 to improve insulation of the coupling bars.

1. Place and insert the coupling bars on the power terminals of the contactor.
2. Place and insert the lugs inwards on the power terminals of the contactor.
3. Insert and tighten the screws at the right torque.

Contactor	Type of screws	Torque
LC1G115-225	Allen key	18±1.8 N•m (159±15.9 lb-in)
LC1G265-500	Inner hexagon	35±3.5 N•m (310±31 lb-in)
LC1G630-800	Inner hexagon	58±5.8 N•m (513±51.3 lb-in)

4. Install the front cover of the terminal shroud.
5. Insert and tighten the screws at the right torque to lock the front cover.

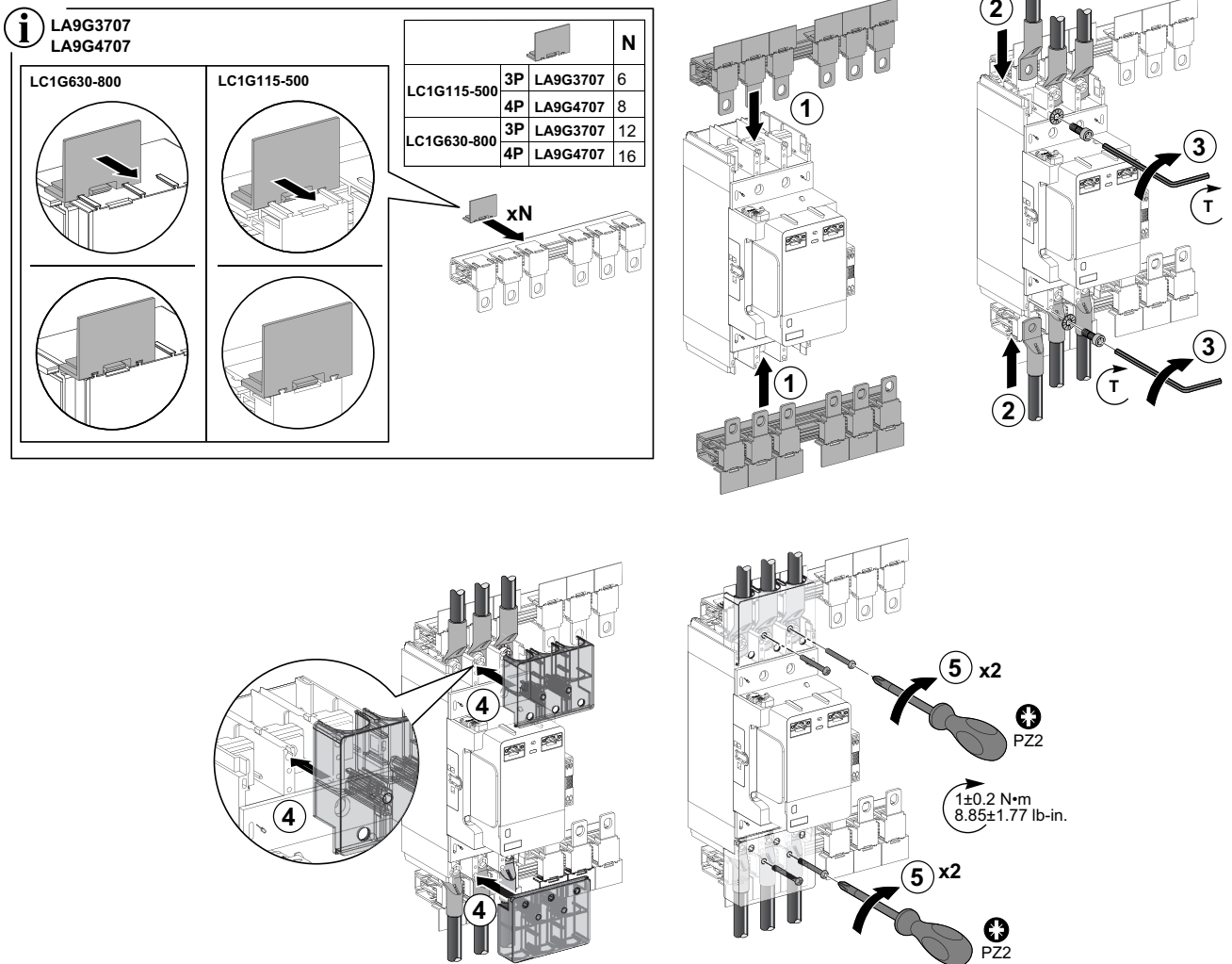

## Phase Separator

### ⚠ WARNING

#### HAZARD OF FLASH OVER BETWEEN POLARITIES

Interphase barriers must be installed if the network voltage is greater than or equal to 690 Vac.

**Failure to follow these instructions can result in death, serious injury, or equipment damage.**

## Overview

The phase separators are installed between the power terminals of the contactor or the overload relay to provide 1000 Vac insulation between phases. They can be installed on the upstream or downstream side of the contactor or overload relay:

- LA9G3801: 2 phase separators.
- LA9G4801: 3 phase separators.

The phase separators are compatible with the power connection accessories, except the large spreaders. Phase separators LA9G3803 or LA9G4803 are delivered with the large spreaders, see *Large Spreaders*, page 114.

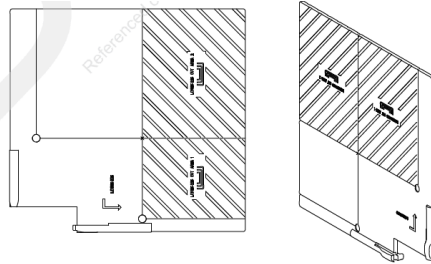

Contactor	Number of poles	Phase separator
LC1G115–800	3P	LA9G3801
	4P	LA9G4801

**NOTE:** Either phase separators or terminal shrouds can only be mounted. Phase separators or terminal shrouds are mandatory for operational voltage,  $U_e \geq 690$  V.

## Overall Dimension

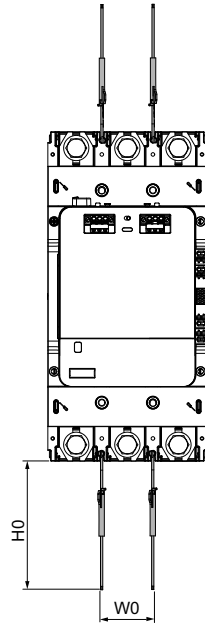
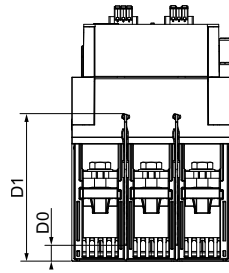

The table below provides the dimension detail and other technical characteristics of the phase separator:

Contactor	Number of poles	W0	H0	D0	D1
LC1G115–250	3P	35 mm (1.37 in.)	110 mm (4.33 in.)	0 mm (0 in.)	116.2 mm (4.57 in.)
	4P	72.5 mm (2.85 in.)	110 mm (4.33 in.)	0 mm (0 in.)	116.2 mm (4.57 in.)
LC1G265–500	3P	45 mm (1.77 in.)	110 mm (4.33 in.)	32 mm (1.25 in.)	113 mm (4.44 in.)
	4P	82.5 mm (3.25 in.)	110 mm (4.33 in.)	0 mm (0 in.)	116.2 mm (4.57 in.)
LC1G630–800	3P	70 mm (2.75 in.)	110 mm (4.33 in.)	32 mm (1.25 in.)	113 mm (4.44 in.)
	4P	107.5 mm (4.23 in.)	110 mm (4.33 in.)	0 mm (0 in.)	116.2 mm (4.57 in.)
LC1G250DC	3P	35 mm (1.37 in.)	110 mm (4.33 in.)	0 mm (0 in.)	116.2 mm (4.57 in.)

## Installation of Phase Separator on Contactors

1. See the direction shown on the phase separator according to the contactor rating to insert it on contactor power terminals.
2. Insert the phase separator in the right direction on the power terminals of the contactor.
3. Push the phase separator inwards to lock it automatically with a click.

LC1G115-225

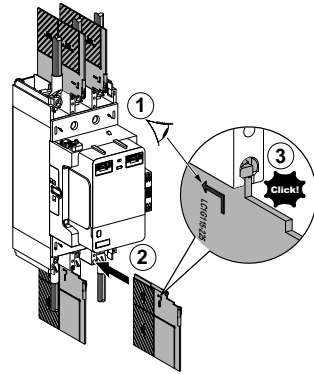

LC1G265-800

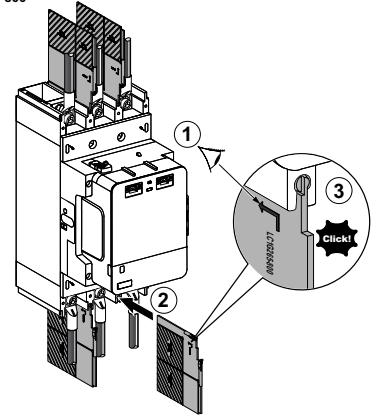

## Installation of Phase Separator on Overload Relays

1. See the direction shown on the phase separator according to the contactor rating corresponding to the rating of the overload relay to insert it on the overload relay power terminals.
2. Insert the phase separator in the right direction on the power terminals of the overload relay.
3. Push the phase separator inwards to lock it automatically with a click.

LR9G115-225

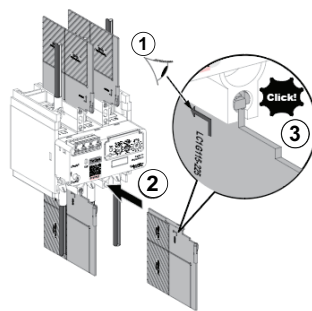

LR9G500-630

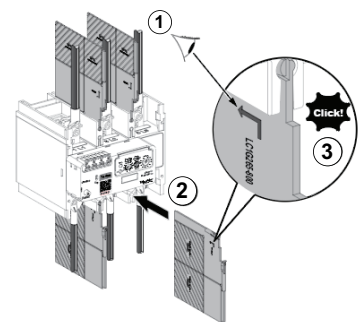

## Installation of Phase Separator with Coupling Bars

1. See the direction shown on the phase separator to cut it according to the contactor rating.
2. Cut the extra part of the phase separator.
3. Insert the phase separator in the right direction on the power terminals of the contactor.
4. Push the phase separator inwards to lock it automatically with a click.

LC1G115-225

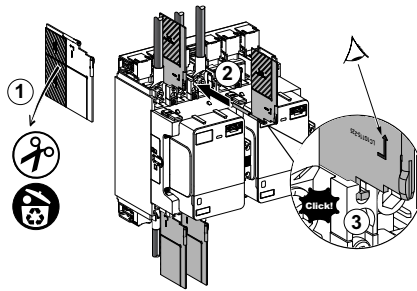

LC1G265-800

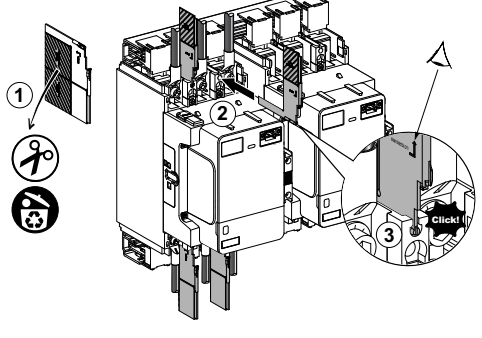

## Functional Accessories

### Auxiliary Contact Modules

#### Overview

Auxiliary contact modules give an indication of the contactor status. It is used for remote visual signaling, alarming, electrical interlocking, and relay activation as required. The auxiliary contact terminals use push-in technology.

There are two types of auxiliary contact modules depending on the contact arrangement:

- 1 NO + 1 NC contacts: LAG8N113 and LAG8N113P with different terminal identification. Each contactor is shipped with one LAG8N113P mounted on the contactor right side.
- 2 NO contacts: LAG8N203 and LAG8N203P with different terminal identification.

The NC auxiliary contacts are mirror of the main pole contact according to IEC 60947-4-1 and UL 60947-4-1 annexure F. The NO and NC auxiliary contacts are mechanically linked according to IEC 60947-5-1 / EN 60947-5-1 and UL 60947-5-1 annexure L.

#### Installation Quantity

Up to four auxiliary contact modules can be mounted on one contactor. All combinations of the auxiliary contact modules are possible with maximum 2 on each side. Between two contactors with mechanical interlock, maximum 2 auxiliary contacts can be mounted with one on each side.

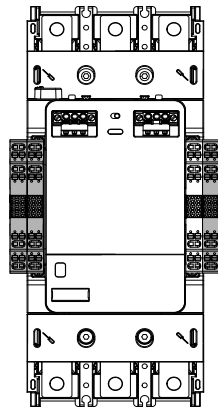

In star-delta application, up to nine auxiliary contact modules can be mounted on three contactors. Refer to the graphic below for the position of these auxiliary contacts modules. For more information on star-delta application, see *Star-Delta Starters*, page 162.

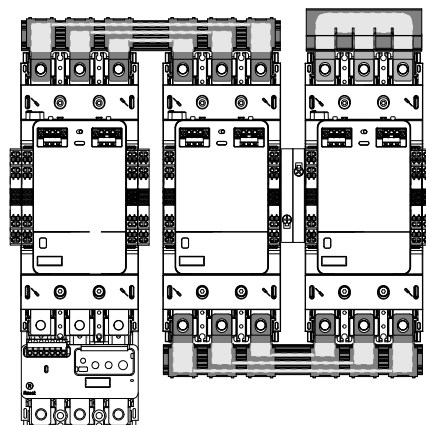

## Auxiliary Contact Module Installation Video

To access a demonstration video about installing auxiliary contact modules on a contactor, you can click here, scan the QR code, or copy and paste the link to your Web browser.



## Installation of the Auxiliary Contact Modules

Make sure that the slider on the auxiliary contact modules should be on the right side before installation.

1. Place the screwdriver on the side of the plastic cover.
2. Push the cover inwards to remove the cover.
3. Place the auxiliary contact modules on the contactor at the fixing holes.
4. Push to lock automatically with a click.

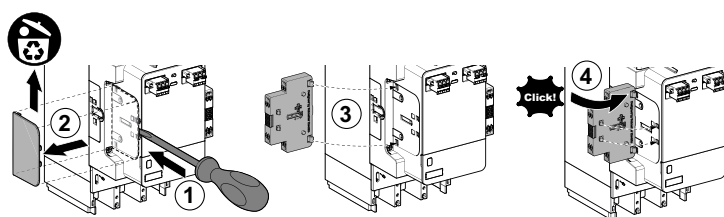
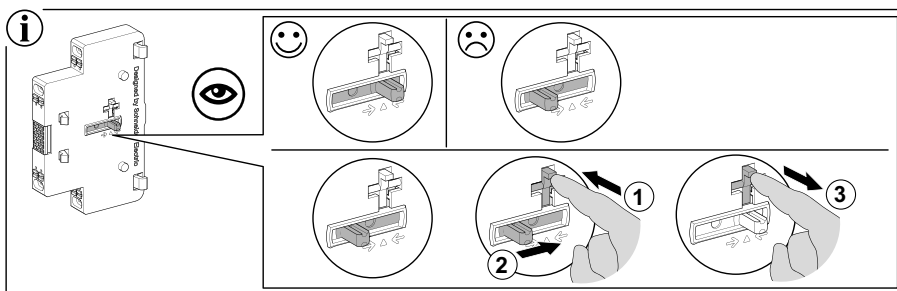

## Removal of the Auxiliary Contact Modules

1. Press the green button on the auxiliary contact modules.
2. Pull out the auxiliary contact modules from the contactor.

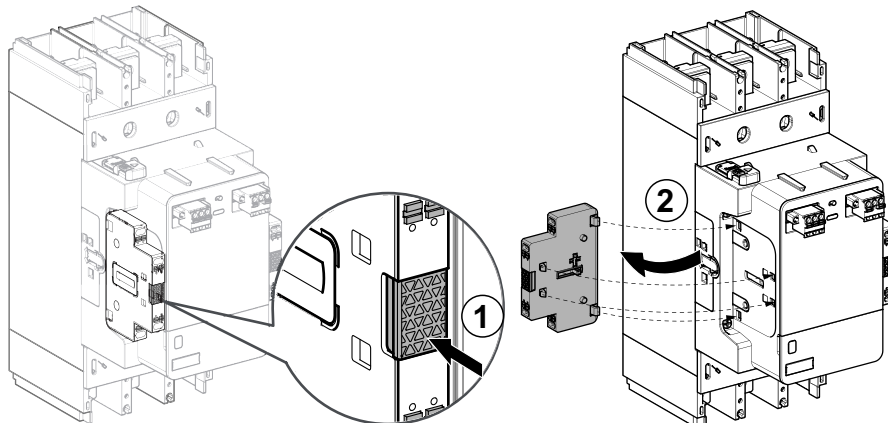

## Conductor Connection

Insert inwards the conductor into the push-in terminal to connect the conductor.

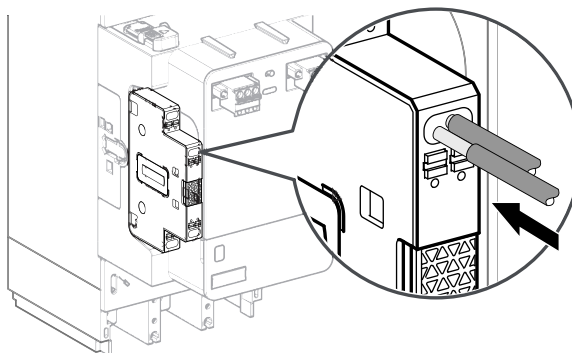

## Removing the Conductor from the Push-in Terminal



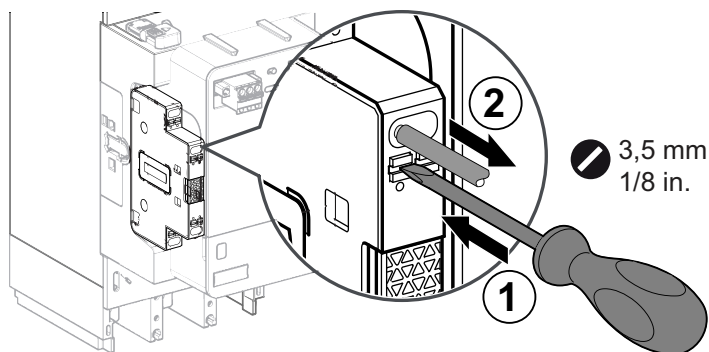

1. Push the button below the conductor with a screwdriver to loosen the connection of the conductor from the push-in terminal.
2. Pull the conductor out from the push-in terminal.

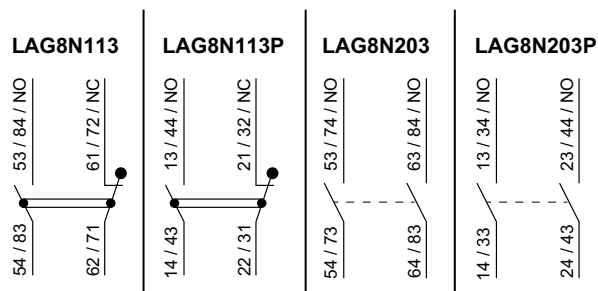

## Wiring Diagrams

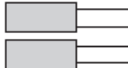

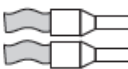
## Wiring Characteristics

Cable type	Stripping length	Number of conductors		Section
Solid cable without cable end	12 mm (0.47 in.)	1 conductor		0.75–2.5 mm <sup>2</sup> (18–14 AWG)
		2 conductors		
Flexible cable with suitable cable end	10 mm (0.40 in.)	1 conductor		0.75–2.5 mm <sup>2</sup> (18–14 AWG)
		2 conductors		
Flexible cable with suitable sleeve	10 mm (0.40 in.)	1 conductor		0.75–2.5 mm <sup>2</sup> (18–14 AWG)
		2 conductors		

## Remote Wear Diagnostic Module

### Overview

The remote wear diagnostic module is used for remote signaling of the wear diagnosis function. It can be installed on advanced contactor only.

The module terminals use push-in technology. There are two types of remote wear diagnostic modules depending on the contact arrangement:

- LA9GRD01: 1 NC contact
- LA9GRD10: 1 NO contact

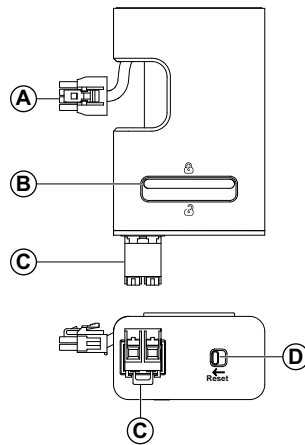

Label	Description
A	Plug to the advanced contactor
B	Unlock button
C	Wear signalization contact terminals
D	Wear diagnosis reset button

### Reset Button

The Reset button has two functions:

- **If wear diagnosis is detected:** switch the Reset button to the left after replacement of the switching modules, to reset the wear diagnosis indication
- **If no wear diagnosis is detected:** you can test the control circuit by changing the position of the Reset button. It will change the position of the contact of the module.

## Remote Wear Diagnostic Module Installation Video

To access a demonstration video about installing the remote wear diagnostic module on a contactor, you can click [here](#), scan the QR code, or copy and paste the link to your Web browser.

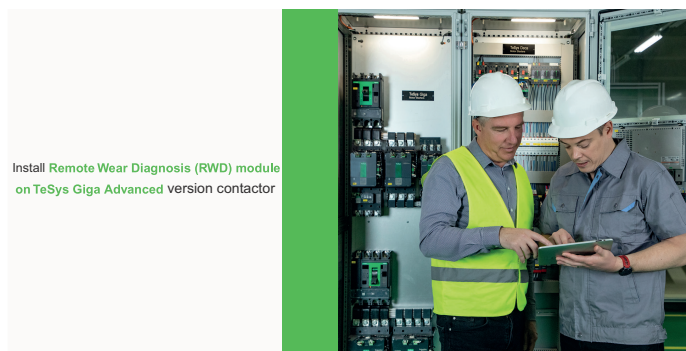

## Installation of Remote Wear Diagnostic Module

1. Press the button of the cap on top of advanced contactor.
2. Pull the cap on top of advanced contactor.
3. Place the remote wear diagnostic module on the contactor and push it inwards to lock it automatically with a click.
4. Connect the cable to lock it automatically with a click.

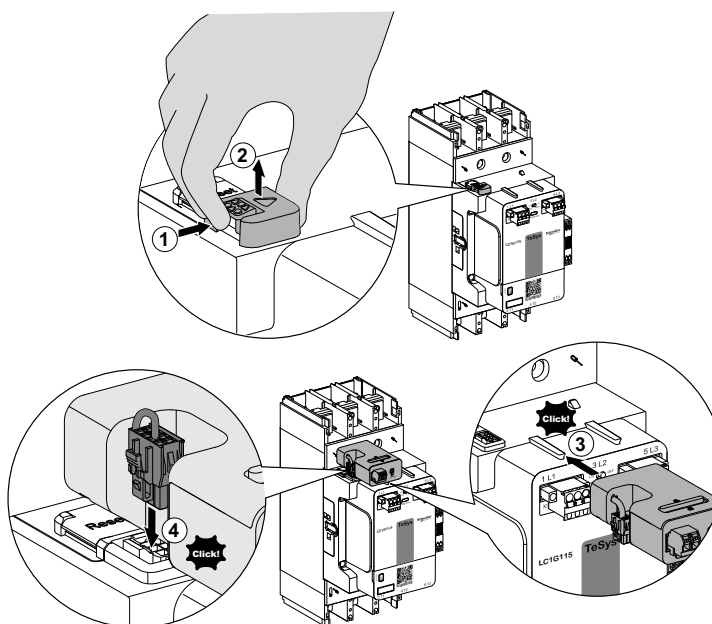

## Removal of Remote Wear Diagnostic Module

1. Remove the cable from remote wear diagnostic module of the advanced contactor.
2. Unlock the remote wear diagnostic module by using the button on the module.
3. Pull outwards to remove the remote wear diagnostic module.

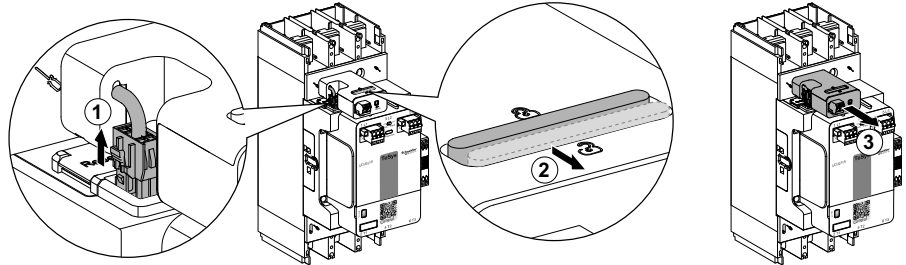

## Conductor Connection

Insert inwards the conductor into the push-in terminal to connect the conductor.

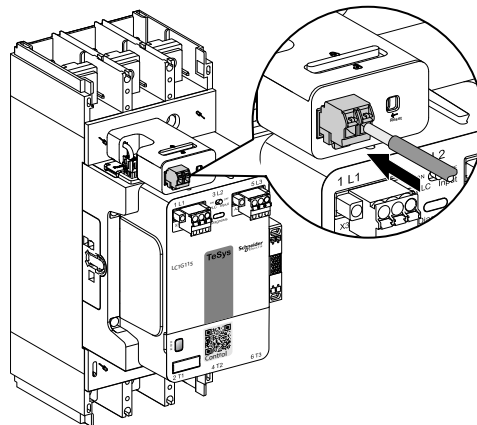

## Removing the Conductor from the Push-in Terminal



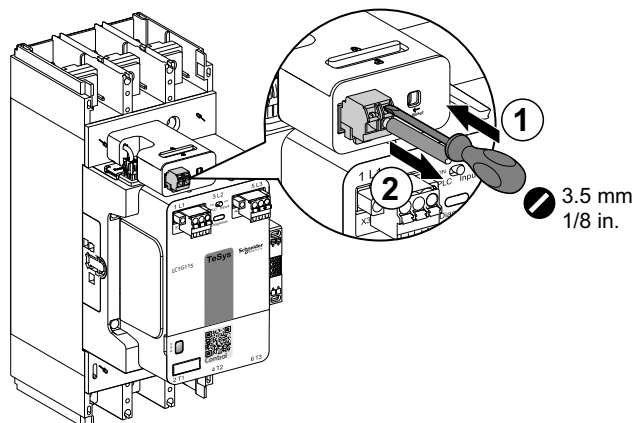

1. Push the button above the conductor with a screwdriver to loosen the connection of the conductor from the push-in terminal.
2. Pull the conductor out from the push-in terminal.

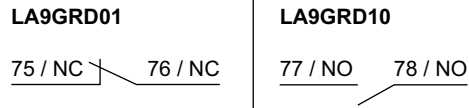

## Wiring Diagrams



## Wiring Characteristics

Cable type	Stripping length	Number of conductors		Section
Solid cable	10 mm (0.40 in.)	1 conductor without cable end		0.2–2.5 mm <sup>2</sup> (26–14 AWG)
		2 conductors with suitable dual sleeve		0.5–1.0 mm <sup>2</sup> (20–18 AWG)
Flexible cable	10 mm (0.47 in.)	1 conductor with suitable cable end or sleeve	 	0.25–2.5 mm <sup>2</sup> (24–14 AWG)
		2 conductors with suitable dual sleeve		0.5–1.0 mm <sup>2</sup> (20–18 AWG)
Do not use flexible cable without cable end or sleeve.				

## Remote Diagnostic Modbus Module

### Overview

Remote Diagnostic Modbus (RDM) module supports Modbus communication and one digital output (DO). It is used to provide diagnosis indications remotely for contactors with a control module with commercial references ending with LSEMN, including:

- main contact wear diagnosis
- coil over-temperature
- coil over-voltage and under-voltage
- control module internal malfunction
- contactor operating times

It can record the latest five diagnosis events. See [Diagnosis Functions](#), page 23.

The table below provides the compatibility of the RDM module with contactors and control modules:

Contactor	Control module	RDM module reference number
LC1G115-225LSEMN	LX1G3QLSEMN	LA9GRDMD
LC1G265-330LSEMN	LX1G3RLSEMN	LA9GRDMD
LC1G400-500LSEMN	LX1G3SLSEMN	LA9GRDMD
LC1G630-800LSEMN	LX1G3TLSEMN	LA9GRDMD

### Hardware Description

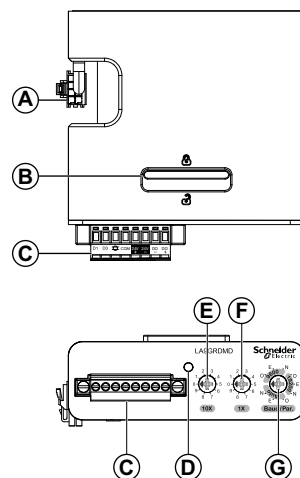

Label	Description
A	Plug to the contactor
B	Unlock trigger
C	Terminal block for digital output, RDM power supply and Modbus communication port
D	LED indicator
E	Modbus address tens-digit knob
F	Modbus address ones-digit knob
G	Baud rate and parity setting knob

## LED Indicator

LED status	Color	Indication
On	Green	Initial idle state after RDM module is powered on. No request received.
	Orange	RDM module is powered on and a Modbus error is detected. See Troubleshooting, page 208 for more details.
	Red	RDM module is not powered and a Modbus error is detected. See Troubleshooting, page 208 for more details.
Blinking	Green and orange	RDM module is powered on, and Modbus communication is ongoing without error.  If a Modbus exception code is returned, see Troubleshooting, page 208 for more details.
Off	-	RDM module is powered off.

## RDM Module Installation and Wiring

### Installation of Remote Diagnosis Modbus Module

1. Press the button of the cap on top of the contactor.
2. Remove the cap. Keep it properly for future use.
3. Place the RDM module on the top of the contactor and push it inwards to lock it automatically with a click.

**NOTE:** Ensure that RDM module is installed along both slots.

4. Connect the cable to lock it automatically with a click.

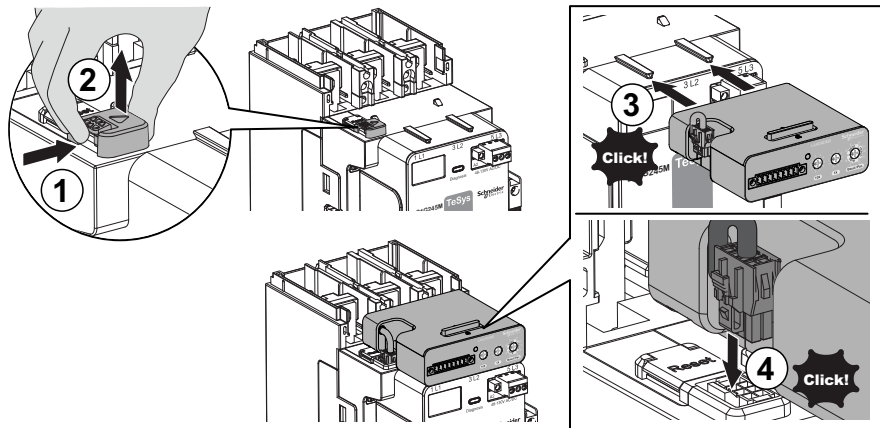

### Removal of Remote Diagnosis Modbus Module

1. Press and hold the button on the side of the plug.
2. Pull out the plug.
3. Toggle the unlock trigger.
4. Pull outwards to remove the RDM module.
5. Put back the top cap.

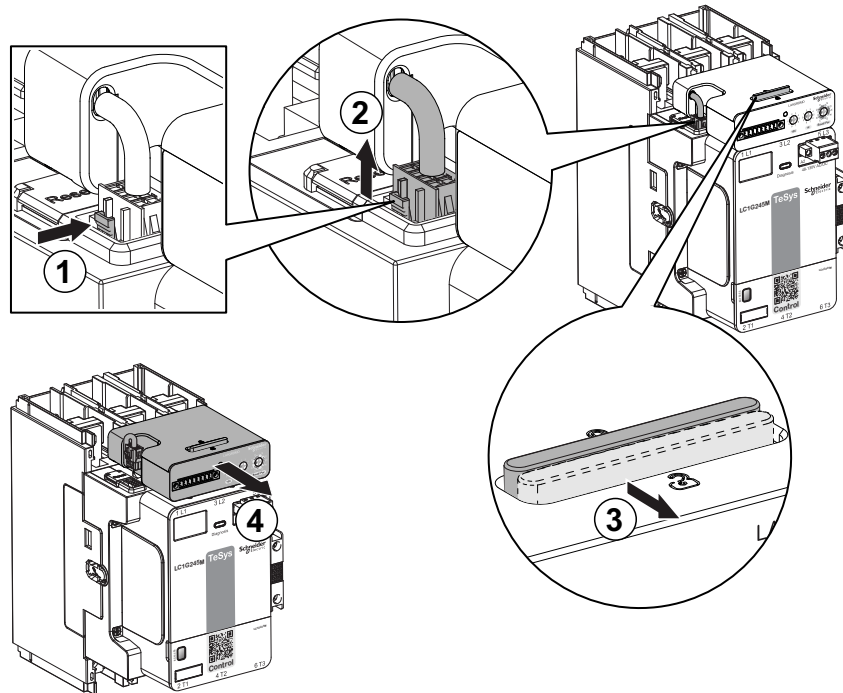

## Conductor Connection

1. Take out the terminal from the packaging box.
2. Insert inwards the conductor into the terminal.
3. Tighten the screws by using a 2.5 mm flathead screwdriver at the right torque (0.2 N.m).
4. Insert the terminal into the RDM module.
5. Tighten the screws at the right torque (0.2 N.m).

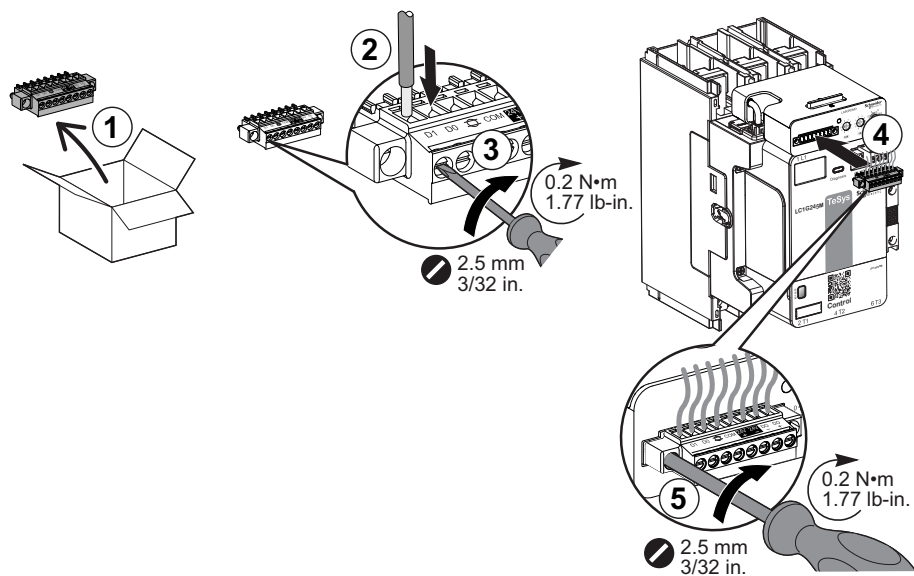

## Conductor Removal

1. Loosen the screws to release the conductor from the terminal by using a 2.5 mm flathead screwdriver at the right torque (0.2 N.m).
2. Pull the conductor out from the terminal.

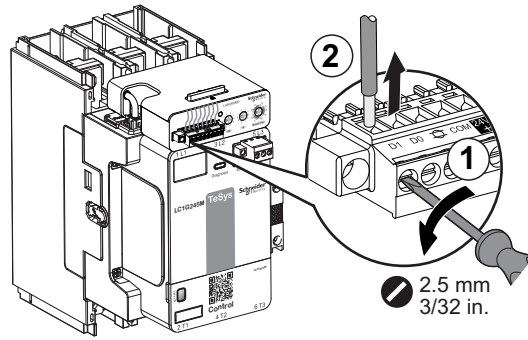

### Wiring Diagram

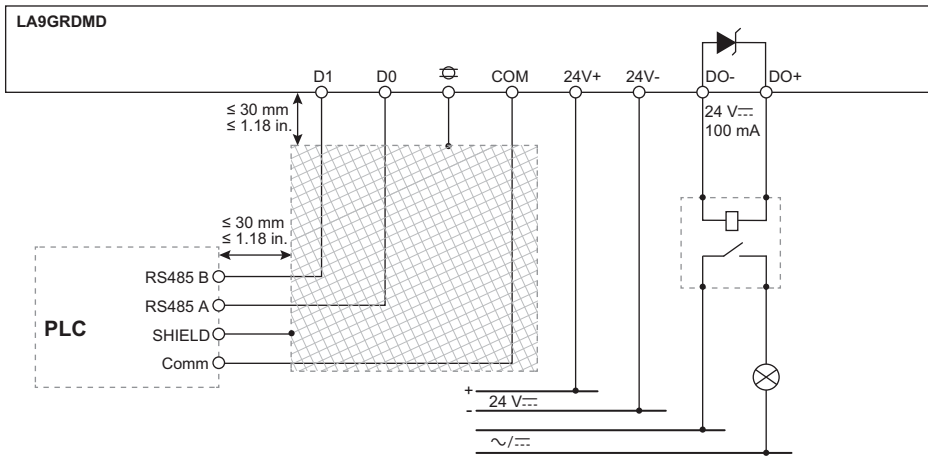



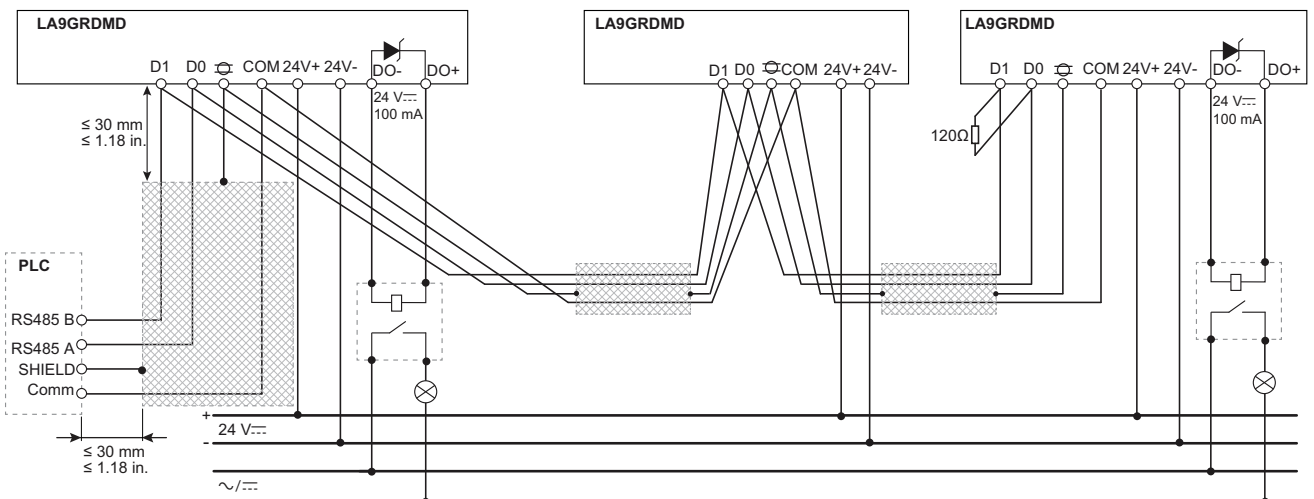

- Use a shielded twisted pair Modbus cable to reduce radiated emissions and improve shielding against external electromagnetic interference.
- A 120 Ω parallel resistor must be connected to D0–D1 when the RDM module is connected at the end of Modbus network.
- The maximum unshielded length of the Modbus cable is 30 mm.

### Modbus Wiring in Daisy Chain Topology

The maximum length of the Modbus cable from the first PLC to the last RDM module is 15 meters. It is suggested to connect no more than 6 RDM modules in the daisy chain to achieve timely and responsive communication. The maximum number of RDM module in the daisy chain is 99.

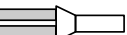

## Wiring Characteristics

Cable type	Stripping length	Number of conductors		Section
Solid cable	6–7 mm	1 conductor without cable end		0.14–1.5 mm <sup>2</sup> 28–14 AWG
		2 conductors with suitable dual end		0.14–0.5 mm <sup>2</sup> 28–20 AWG
Flexible cable		1 conductor with suitable cable end or sleeve	 	0.25–0.5 mm <sup>2</sup> 24–22 AWG
		2 conductors with suitable dual sleeve		0.5 mm <sup>2</sup> 22 AWG
Modbus cable (shielded twisted pair cable)	6–7 mm	-		0.14–1.5 mm <sup>2</sup> 28–14 AWG

**NOTE:**

- Do not use flexible cable without cable end or sleeve.
- Follow the National Electrical Code and local regulations when installing the communication wiring.

For more information about Modbus wiring and application, please refer to "MODBUS over Serial Line Specification & Implementation guide V1.1" on [modbus.org](http://modbus.org).

## Modbus Communication Setting

### General Settings

Item	Setting
Address	1–99
Broadcast	No
Transmission mode	RTU
Baud rate (bps)	Auto <sup>(1)</sup> : auto mode, support Baud rate of 9600, 19200, 38400, 57600, 115200 9600 19200
Parity	O: Odd parity E: Even parity N: None parity
Data bit number	8
Stop bit number	1 <sup>(2)</sup>

<sup>(1)</sup>The first 10 data packages will not be responded when Auto mode is adapting.

<sup>(2)</sup> The stop bit is set to 1 by default for all parity setting.

### Configuring Modbus Address

RDM module supports Modbus addresses from 1 to 99. It can be set using the 2 setting knobs on the module.

The address setting will be effective once the contactor is powered on. If you want to change the address setting, disconnect the power, modify the setting and power on the contactor again.

Follow the steps below to set the Modbus address:

1. Insert a Phillips screwdriver to the setting knob.
2. Turn the knobs to set the tens-digit and ones-digit of the Modbus address.

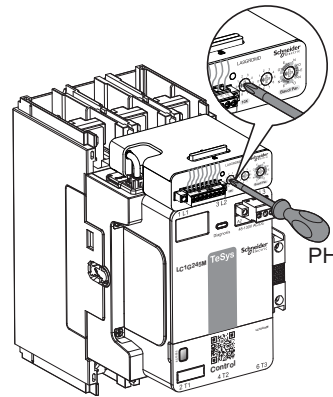

### Configuring Baud Rate and Parity

RDM module supports baud rate up to 115200 bps and setting parity to odd, even or none.

Use the same knob to set the baud rate and parity. The setting will be effective once the contactor is powered on. If you want to change the setting, disconnect the power, modify the setting and power on the contactor again..

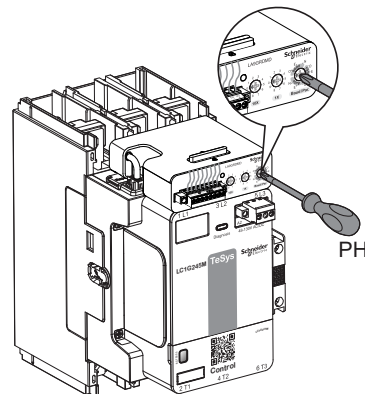

### Modbus Function Code

RDM module supports the following Modbus function codes:

- Read: 03 - Read Holding Registers
- Write: 06 - Write Single Register
- Write: 16 - Write Multiple Registers

### Modbus Exception Code

The following table describes the exception codes handled by RDM module.

Exception code	Name	Description
01 (0x01)	Illegal function	The function code received in the request is not an authorized action for the server.
02 (0x02)	Illegal data address	The data address received by the server is not an authorized address for the server.
03 (0x03)	Illegal data value	The value in the request data field is not an authorized value for the server.
04 (0x04)	Server failure	The server fails to perform a requested action because of an unrecoverable error.

## Digital Output Setting

Digital output for diagnosis indications except for internal malfunction can be set to enabled or disabled. By default, all diagnosis indications except for internal malfunction are disabled. Internal malfunction indication is fixed as enabled.

Set the bit to 1 to enable the digital output of alarms, and set to 0 to disable it. The reserved bits without any diagnosis indication should also be set to 0. The digital output configuration is written to the register 61701 with Modbus function code 06 or 16. See [Modbus Registers](#) for more information.

## Modbus Register Tables

### Table Formats

Register tables have the following columns:

Address	Register	Number of 16-bit registers	R/W	Type	Description
---------	----------	----------------------------	-----	------	-------------

Designation	Description
Address	16-bit register address in hexadecimal. The address is the data used in the Modbus frame.
Register	16-bit register number in decimal. Register = Address + 1. For example, the register 60001 is addressed as 0xEA60.
Number of 16-bit registers	Number of 16-bit registers that need to be read / written to access the complete information.
R/W	Whether the register is read only (R) or read-write (RW).
Type	Coding data type (see Data Types table below).
Description	Information about the register and restrictions that apply.

### Data Types

Name	Description
UINT16	16-bit unsigned integer (1 word)
UINT32	32-bit unsigned integer (2 word)
ASCII	String of 8-bit alphanumeric character

### Register Table

Address	Register	Number of 16-bit registers	R/W	Type	Description
0xEA60	60001	9	R	ASCII	The vendor's name of the product: Schneider Electric
0xEA69	60010	32	R	ASCII	The URL of the vendor: <a href="https://www.se.com/">https://www.se.com/</a>
0xEAC4	60101	8	R	ASCII	Product range name: TeSys Control
0xEADC	60125	8	R	ASCII	Product family name: Motor Starter
0xEB32	60211	1	R	UINT16	Internal numerical identifier of the product: 19800
0xEB33	60212	20	R	ASCII	Serial number of control module. A unique number of each control module delivered.
0xEF11	61202	1	R	UINT16	Status of the contactor: 0: Open 1: Close

Address	Register	Number of 16-bit registers	R/W	Type	Description
0xEF75	61302	1	R	UINT16	<p>Bitmap for diagnosis indication:</p> <p>0: Inactive</p> <p>1: Active</p> <p>Bit definition:</p> <p>bit 0: The remaining service life of contacts is below 15%</p> <p>bit 4: Control voltage estimated value is over the maximum value of rated control voltage range</p> <p>bit 5: Control voltage estimated value is under the minimum value of rated control voltage range</p> <p>bit 7: Control module temperature is over the operation limit</p> <p>Other bits: Reserved</p>
0xEF76	61303	1	R	UINT16	<p>Bitmap for internal malfunction indication:</p> <p>0: Inactive</p> <p>1: Active</p> <p>Bit definition:</p> <p>bit 1: EEPROM error</p> <p>Other bits: Reserved</p>
0xEFDD	61406	1	R	UINT16	The actual control voltage (V)
0xF03C	61501	2	R	UINT32	The number of operations performed by the contactor during its lifetime
0xF0A0	61601	2	R	UINT32	Event record 1 (latest record), see Event Records, page 154
0xF0A2	61603	2	R	UINT32	Event record 2, see Event Records, page 154
0xF0A4	61605	2	R	UINT32	Event record 3, see Event Records, page 154
0xF0A8	61609	2	R	UINT32	Event record 4, see Event Records, page 154
0xF0AA	61611	2	R	UINT32	Event record 5, see Event Records, page 154
0xF105	61702	1	R/W	UINT16	<p>Digital output mapping for diagnosis indication</p> <p>0: Disabled (default)</p> <p>1: Enabled</p> <p>Bit definition:</p> <p>bit 0: The remaining service life of contacts is below 15%</p> <p>bit 1: Control voltage estimated value is over the maximum value of rated control voltage range</p> <p>bit 2: Control voltage estimated value is under the minimum value of rated control voltage range</p> <p>bit 3: Control module temperature is over the operation limit</p> <p>Other bits: Reserved (must be set to 0)</p>
<p><b>NOTE:</b> The RDM module will answer with invalid data 0x8000 if an unused register is read. See Troubleshooting, page 208 for more details.</p>					

## Event Records

The RDM module records the last 5 encountered events. Event record 1 shows the latest event, and event record 5 shows the oldest event. Earlier event records are overwritten by new ones.

Each event record consists of two 16-bit registers:

Event index (UINT8 )	Event type (UINT8)
Event data (UINT16)	

- Register 1 MSB: unique index of each event record. It increases with the occurrence of events, from 0x01 to 0xFF.
- Register 1 LSB: type of events. See the following table.
- Register 2: data related to the event. See the following table.

Type of the event	Data related to the event	Event description
0x01	0xFFFF (N/A)	Wear diagnostic alarm activated
0x02	Voltage RMS in V	Contactors over voltage detected
0x03	Voltage RMS in V	Contactors under voltage detected
0x04	0xFFFF (N/A)	Contactors over temperature detected
0xFF	0xFFFF (N/A)	No event. Default event for event record

## Physical Security of the Device

The following is the important physical security point to keep in mind for installing the device:

For Modbus-RTU accessories which are recognized as having security risks in the industry, physical security measures (such as dedicated pipes) are recommended to protect communication cables from unauthorized access, communication drops, data leakage and tampering, etc.

# Applications

## What's in This Chapter

Safety Applications .....	156
Single-Phase Motor Application .....	161
Star-Delta Starters .....	162
Two Contactors Reverser .....	178
Two Contactors Changeover .....	184

## Safety Applications

TeSys Giga advanced contactors and TeSys Giga standard contactors can be used in safety applications. In such applications they are parts of the safety chain as safety related components and switch off the motor supply performing a Stop Category 0 as defined by IEC 60204-1.

They are controlled by the outputs of a safety PLC or a safety relay or a safety switch and provide a highly reliable monitoring of their status, if needed, thanks to the mirror auxiliary contacts.

Auxiliary contacts give an indication of the contactor status. They can be used for remote visual signalling, alarming, electrical locking, relay activation, etc...

Each contactor is equipped with 1 NO + 1 NC auxiliary contact module as standard. The NC contact of the auxiliary contact module is mirror contact in conformity to IEC 60947-4-1 and it is mechanically linked to reliably represent the state of the main power contacts and wherever auxiliary contact state reliability is essential. The main power contacts and the NC of the auxiliary contact can't be closed at the same time.

Type of connection: push-in type.

The use of a mirror contact wired to an input of the safety PLC or the safety relay and read continuously by the system allows to increase the diagnostic coverage of this subsystem up to 99%.

4 electrical diagrams are possible to perform a Stop Category 0 according to:

- The type of contactor, advanced or standard.
- The control mode of the advanced contactor.

### **⚠ WARNING**

#### **UNINTENDED EQUIPMENT OPERATION**

Size the command components according to the characteristics of the contactor control module.

**Failure to follow these instructions can result in death, serious injury, or equipment damage.**

## Advanced Contactor Without Using the PLC Inputs

The **PLC Input** switch of the advanced contactor is on the OFF position.

In case of safety stop, the poles are open as soon as the control voltage is removed from A1-A2 control module terminals.

The characteristics of the components that controls the contactor must be compatible with the characteristics of the control module.

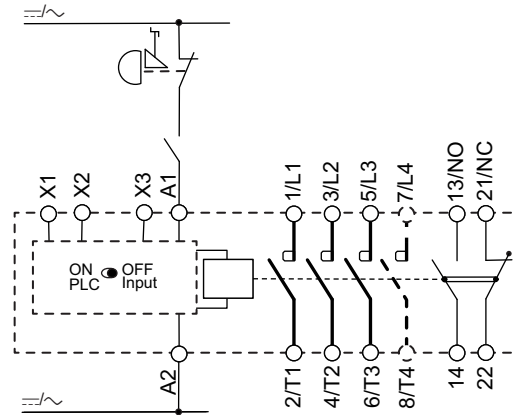

## Advanced Contactor Using the PLC Inputs for Standard Operation and for the Safety Stop

The **PLC Input** switch of the advanced contactor is on the ON position.

A1-A2 control module terminals are used to supply the electronics and the coil of the control module.

X1-X2-X3 control module terminals are used to close and open the contactor in standard operation or safety stop. In case of safety stop, the poles are open as soon as the command on X3 terminals is OFF. The input X3 is fail-safe.

The characteristics of the components that controls the contactor must be compatible with the characteristics of the control module.

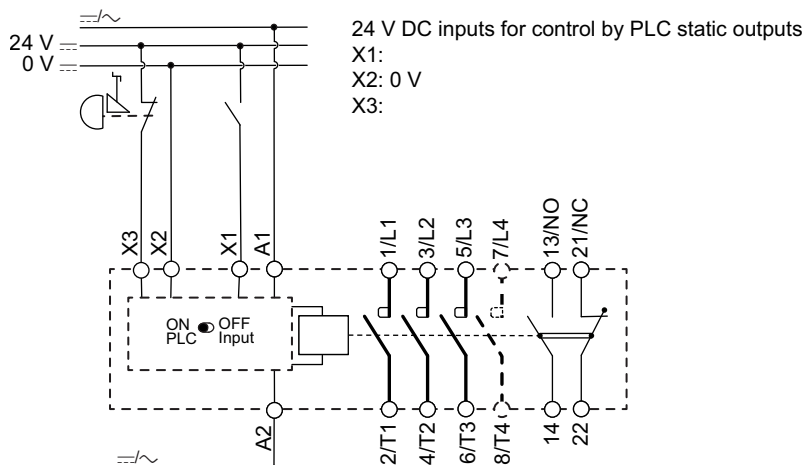

## Advanced Contactor Using the PLC Inputs for Standard Operation and Removing the Control Voltage on A1 A2 in case of Safety Stop

The **PLC Input** switch of the advanced contactor is on the ON position.

A1-A2 control module terminals are used to supply the electronics and the coil of the control module.

X1-X2-X3 control module terminals are used to close and open the contactor in standard operation.

In case of safety stop, the poles are open as soon as the control voltage is removed from A1-A2 control module terminals.

The characteristics of the components that controls the contactor must be compatible with the characteristics of the control module.

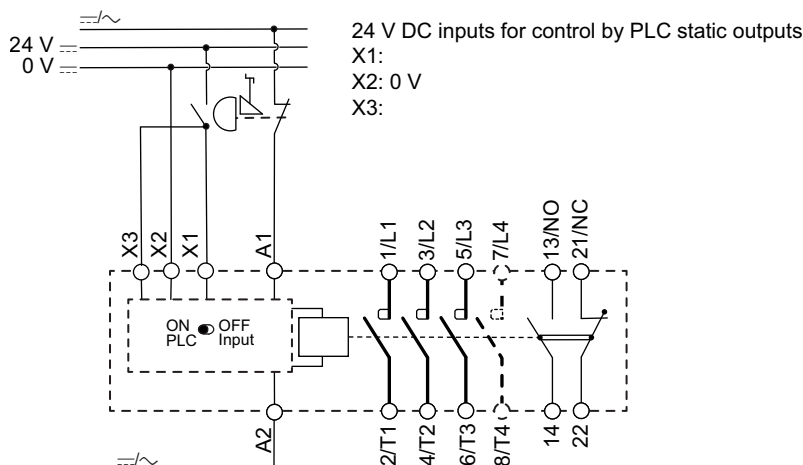

## Standard Contactor

In case of safety stop, the poles are open as soon as the control voltage is removed from A1-A2 control module terminals.

The characteristics of the components that controls the contactor must be compatible with the characteristics of the control module.

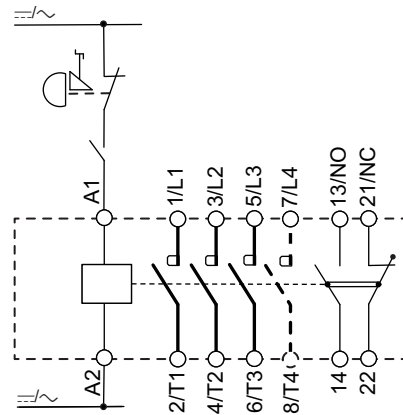

## SIL2 Application Example

SIL2 application example of guard monitoring with

- coded magnetic switches
- safety module
- two advanced contactors using the PLC Inputs for standard operation and for the safety stop

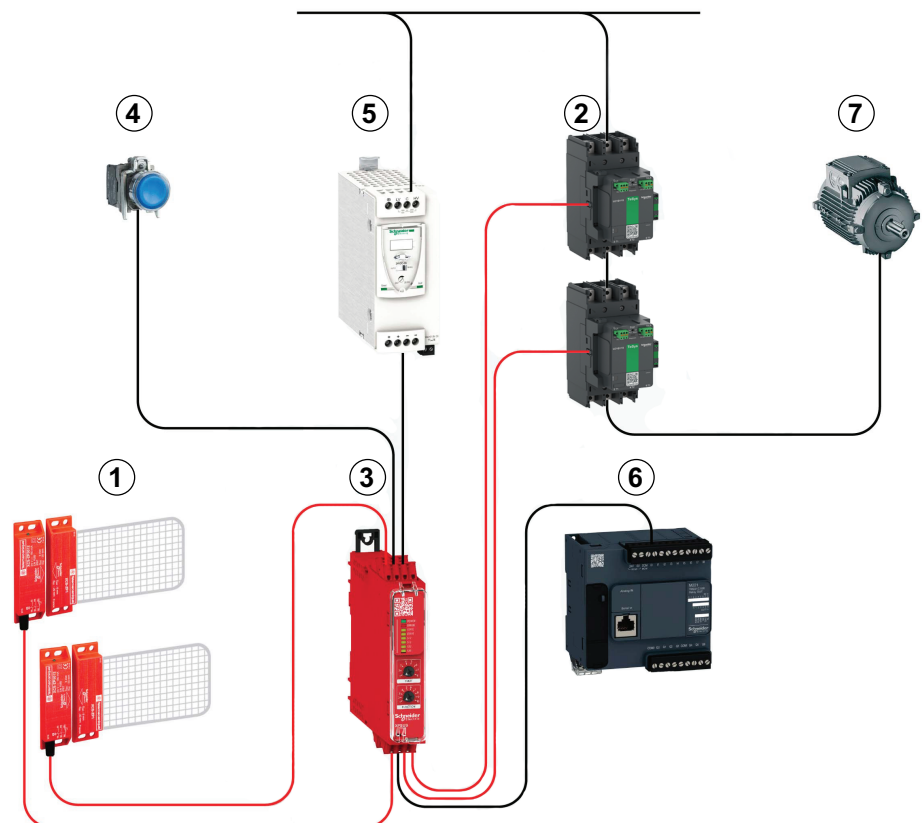

Number	Device	Remarks
1	XCSOMP590L01M12	Two coded magnetic switches with antivalent outputs (one NO, one NC each).
2	LC1G●●●A	Two TeSys Giga advanced contactors  The hardware overview does not show details on the connection between the mirror contacts of the advanced contactors and the safety module.
3	XPSUS12	Safety module
4	Harmony XB4	Push-button for monitored start/restart. This push-button is used to provide the signal to exit the defined safe state of the Safety Chain Solution. It does not start/restart the overall machine or process.
5	ABL●●●	Power supply
6	M221 Logic controller	Digital input connected to status output of safety module
7	Motor	-

For application examples refer to [Safety Chain Solution Guide](#).

## Safety Stop Category 0 Test Procedure

The Safety Stop Category 0 function must be tested at regular intervals, in accordance with standards and local regulation.

In absence of local regulation, Schneider Electric recommends to carry out the Safety Stop Category 0 test procedure once a year.

1. Switch off the power by opening the upstream circuit breaker or switch-disconnector.
2. Close the contactor(s).
3. Push the emergency stop push button.
4. Check that the contactor(s) are open.
5. Check that the NC auxiliary contacts of the contactor(s) (21-22, 31-32, 61-62, 71-72) are closed.
6. Rearm the emergency stop system.
7. Close the contactor(s).
8. Check that the NC auxiliary contacts of the contactor(s) (21-22, 31-32, 61-62, 71-72) are open.

If one of the checks is not successful, refer to [Troubleshooting](#), page 208.

# Single-Phase Motor Application

## Overview

TeSys Giga contactors and TeSys Giga overload relays can be used to control and protect single-phase asynchronous motors.

TeSys Giga overload relay protects single-phase motor from thermal overload. Thermal overload protection must be set according to the application, see Thermal Overload Protection, page 34.

To avoid nuisance tripping, phase imbalance protection (see Phase Imbalance Protection, page 39) and ground-fault protection (see Ground Fault Protection, page 40) must be disabled.

## Wiring Diagram

The single-phase motor must be connected as indicated in the wiring diagrams below.

**Connection to overload relay and contactor assembled**

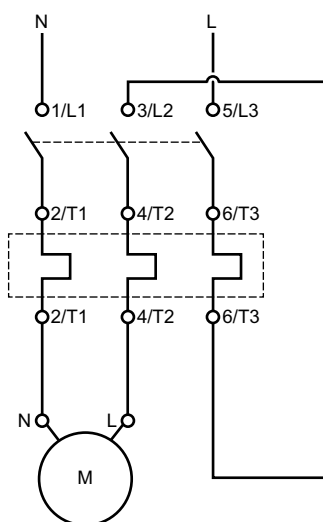

**Connection to standalone overload relay**

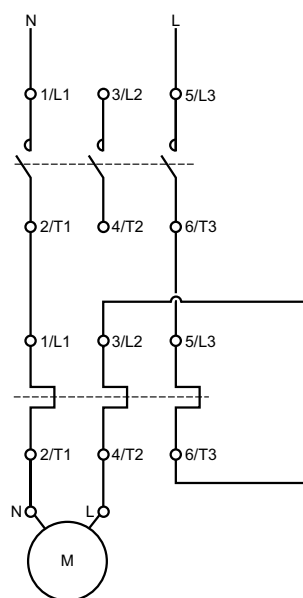

# Star-Delta Starters

## Star-Delta Application Description

Star-delta (or wye-delta) motor starting is used for:

- motors starting on no-load.
- motors having a low load torque.
- motor with load torque increasing with the speed to reduce the stress in the motor and in the distribution network when motor starts.

Examples of this application are fans, compressors with exhaust air and pumps starting with closed valve.

The characteristics of the star-delta starting method are:

- reduction of the starting current.
- reduction of the voltage drop.

This method of starting is applicable to three-phase motors on which all six stator terminals are accessible and whose delta connection voltage corresponds to the main voltage. It requires the combination of three contactors. It helps to start the motor with reduced voltage due to the star connection of the stator windings:

- the starting torque in star connection is reduced to one third of the direct starting torque, that is about 50% of the rated torque.
- the starting current in star connection is about 1.8–2.6 times the rated current.

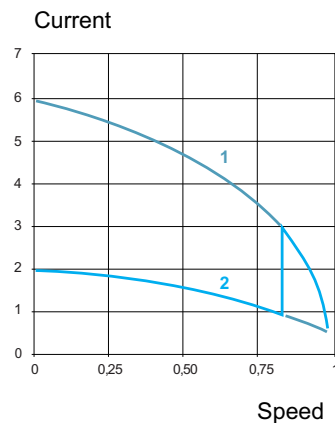

1 Starting in direct delta connection  
2 Starting in star connection

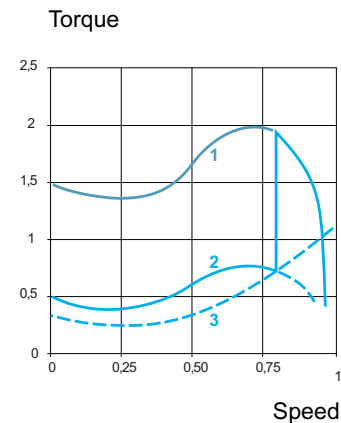

1 Starting in direct delta connection  
2 Starting in star connection  
3 Resistive torque of the machine (specified by the machine manufacturer)

The transition from star to delta connection should occur when the machine has run up to its speed. A too rapid build-up in load torque would cause the stabilized run-up speed to be too low and would therefore eliminate any advantage in this method of starting. This is the case with certain machines whose load torque depends on the machine speed (a characteristic of centrifugal machines, for example).

## Star-Delta Contactors

The star-delta starter requires the combination of three contactors:

- The line contactor (L, KM2)
- The star contactor (Y, KM1)
- The delta contactor ( $\Delta$ , KM3)

The line and delta contactors have the same rating and are rated for the motor  $FLA / \sqrt{3}$ .

The star contactor is rated for the motor  $FLA / 3$ . The size of the star contactor can be

- the same as the size of the line and delta contactors.
- the size under the size of the line and delta contactors.

The star and delta contactors must be mechanically and electrically interlocked to avoid short-circuit during transition of the motor stator connections.

The mechanical interlock depends on the type of the three contactors.

Line and delta contactors	Star contactor	Mechanical interlock	Overload relay
LC1G115-225	LC1G115-225	LA9G970	LR9G115-225
LC1G265-500	LC1G265-500	LA9G970	LR9G500
LC1G630-800	LC1G630-800	LA9G973	LR9G630
LC1G265-500	LC1G115-225	LA9G971	LR9G500
LC1G630-800	LC1G265-500	LA9G972	LR9G630

## Overload Protection of the Star-Delta Starters

The thermal overload protection of the motor in a star-delta starter can be provided by a TeSys Giga overload relay. The overload relay rating is the same as the rating of the line and delta contactors. The  $I_r/FLA$  threshold of the thermal overload protection is set to the motor  $FLA / \sqrt{3}$ .

The thermal overload relay can be

- mounted directly under the line contactor (recommended) or
- mounted standalone and connected between the motor stator terminals and the delta contactor.

For more information on the star-delta starter power circuit and control circuit diagrams, refer to Power Wiring Diagram, page 172 and Control Wiring Diagram, page 176.

## Star-Delta Assembly Video

To access a demonstration video about the assembly of three contactors for a star-delta application, you can click [here](#), scan the QR code, or copy and paste the link to your Web browser.

Assembly of Star-delta starter solution with TeSys Giga contactors



[www.youtube.com/watch?v=2pgK5jOoHEM](http://www.youtube.com/watch?v=2pgK5jOoHEM)

## Mounting Star-Delta Contactors on Plate

Perform the following procedure to mount the star-delta contactors on the plate.

1. Drill 12 holes in the plate, with respect of the dimensions given.

- LC1G115-500 - Maximum hole diameter: 6 mm (0.23 in.)
- LC1G630-800 - Maximum hole diameter: 9 mm (0.35 in.)

**NOTE:** To ease the mounting, drilling stencils JYT1902701 can be downloaded from the [www.se.com](http://www.se.com) website.

**Star-delta starter with three contactors of the same size:**

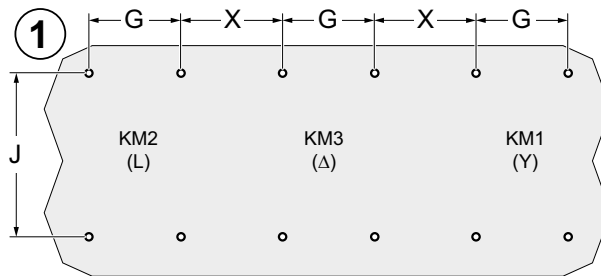

Contactor	G	J	X
LC1G115-225	35 mm (1.38 in.)	166 mm (6.53 in.)	92,7 mm (3.65 in.)
LC1G265-500	45 mm (1.77 in.)	187 mm (7.36 in.)	115 mm (4.53 in.)
LC1G630-800	70 mm (2.75 in.)	242 mm (9.52 in.)	160 mm (6.29 in.)

**Star-delta starter with LC1G265-500 line and delta contactors and LC1G115-225 star contactor.**

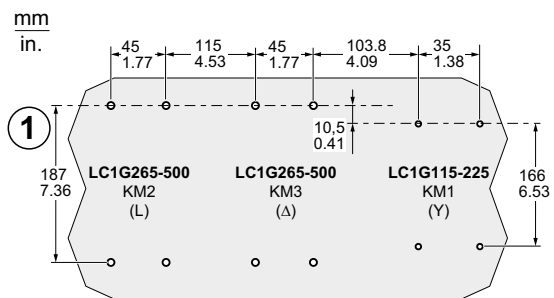

**Star-delta starter with LC1G630-800 line and delta contactors and LC1G265-500 star contactor.**

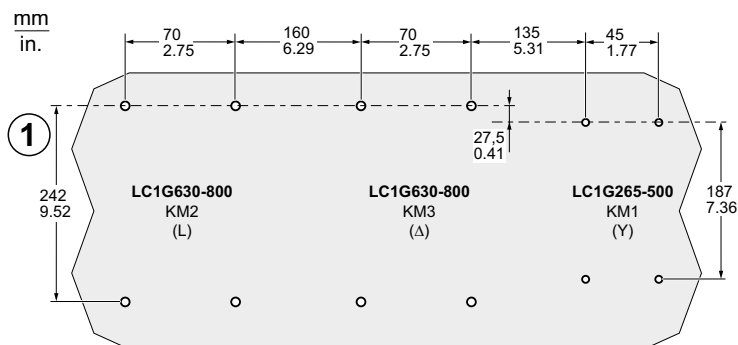

2. Remove the plastic part on the side of the star and delta contactors, where the mechanical interlock will be installed.
3. Discard the plastic part into the bin.

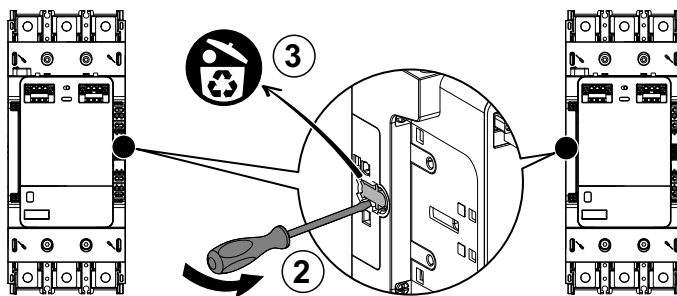

4. Insert the metal slides on the holes of the star and delta contactors.

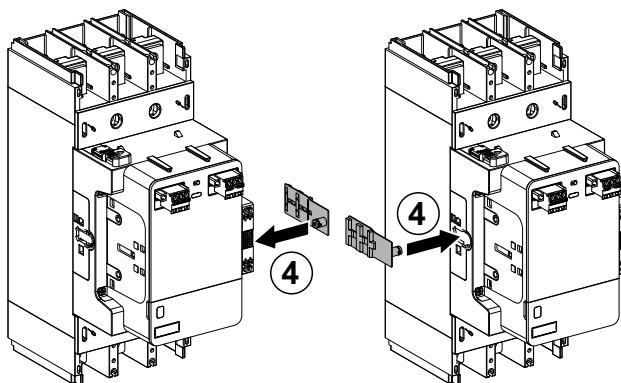

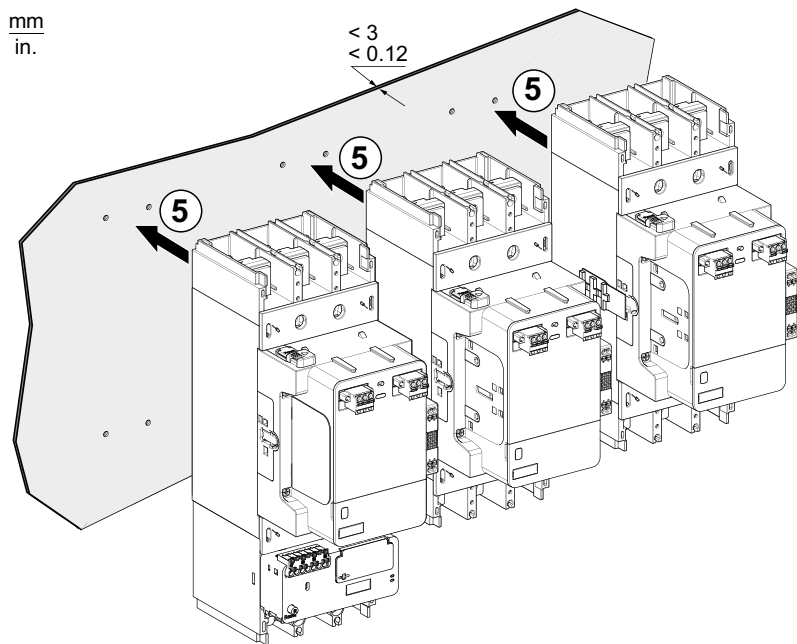

5. Mount each contactor on the plate. Consult the relevant instructions:

- For mounting LC1G115–225 contactors, see Mounting LC1G115-250 Contactors on Plate, page 75
- For mounting LC1G265–800 contactors, see Mounting LC1G265-500 Contactors on Plate, page 76

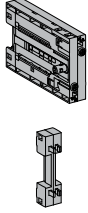
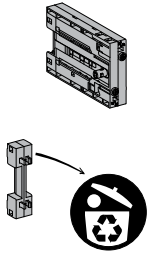
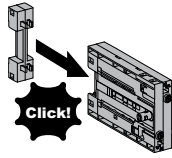
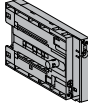
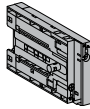
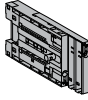

6. Assemble the mechanical interlock LA9G970 between star and delta contactors of the same size according to the size of the contactors.

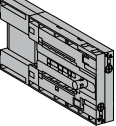
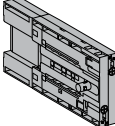
	LC1G115–225	LC1G265–500	LC1G630–800
<b>LA9G970</b> 			-
<b>LA9G971</b> 			-
<b>LA9G972</b> 	-		
<b>LA9G973</b> 	-		

**NOTE:**

- The mechanical interlock LA9G971 and LA9G972 between star and delta contactors of different sizes do not need to be adapted.
- To install the mechanical interlock, maximum 1 auxiliary contact is allowed on each side between star and delta contacts.

7. Insert the mechanical interlock between the star and delta contactors on the metal slides.

8. Tighten the two screws at the right torque to lock the interlock.

mm  
in.

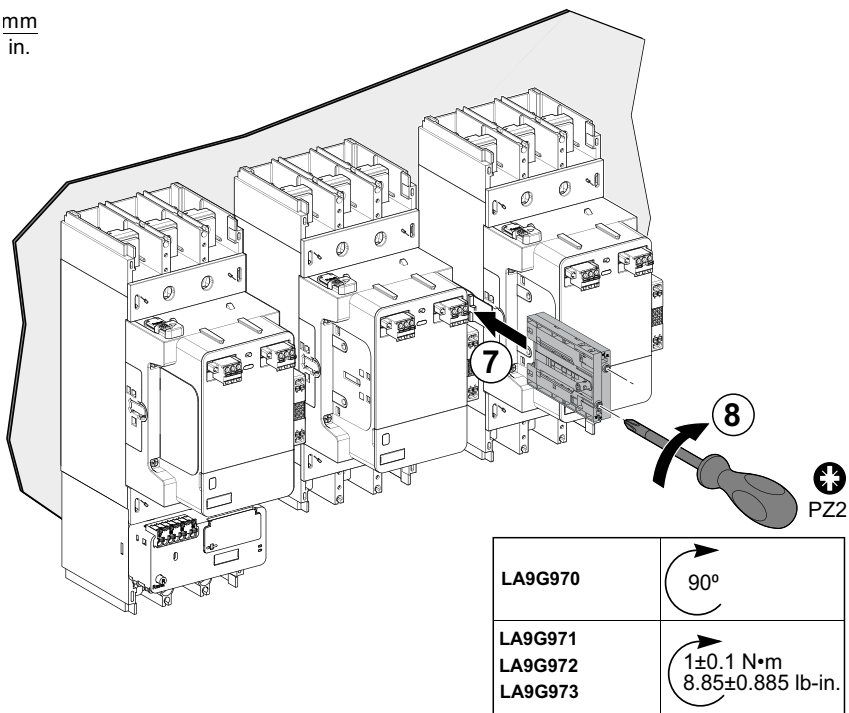

## Power Connection with Star-Delta Connection Kits

### Overview

Star-Delta connection kits can be used for the power connections of the three contactors. These connection kits can be used for contactors with or without cable memory. Check the below table for selection of suitable star-delta connection kits.

Star-delta connection kits are made of three coupling bars:

- the line-delta coupling bar, to couple the line and delta contactors with identical ratings
- the star-delta coupling bar, to couple the star and delta contactors.
- the star coupling bar to couple the motor stator windings.

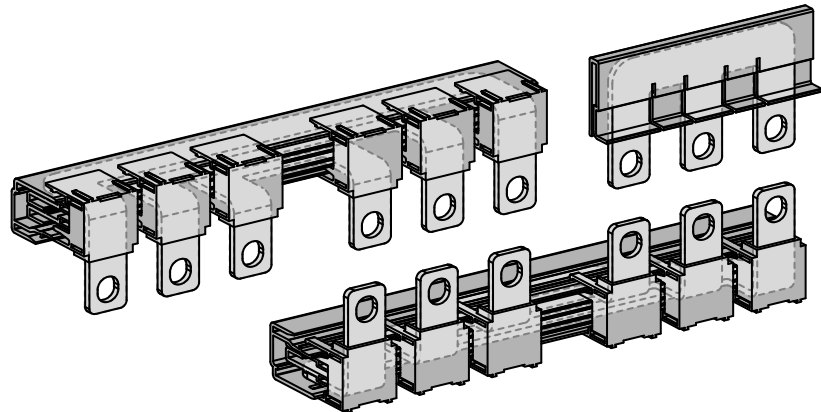

The table below provides the list of the star-delta connection kits:

Contactor version	Line and delta contactors	Star contactor	Star-delta connection kit
Advanced or standard with cable memory	LC1G115-225	LC1G115-225	LA9GQQ330
	LC1G265-500	LC1G265-500	LA9GSS330
	LC1G630-800	LC1G630-800	LA9GTT330
	LC1G265-500	LC1G115-225	LA9GSQ331
	LC1G630-800	LC1G265-500	LA9GTS331
Standard without cable memory	LC1G115-225	LC1G115-225	LA9GQQ330
	LC1G265-500	LC1G265-500	LA9GSS330
	LC1G630-800	LC1G630-800	LA9GTT330
	LC1G265-500	LC1G115-225	LA9GSQ330
	LC1G630-800	LC1G265-500	LA9GTS330

## Dimensions

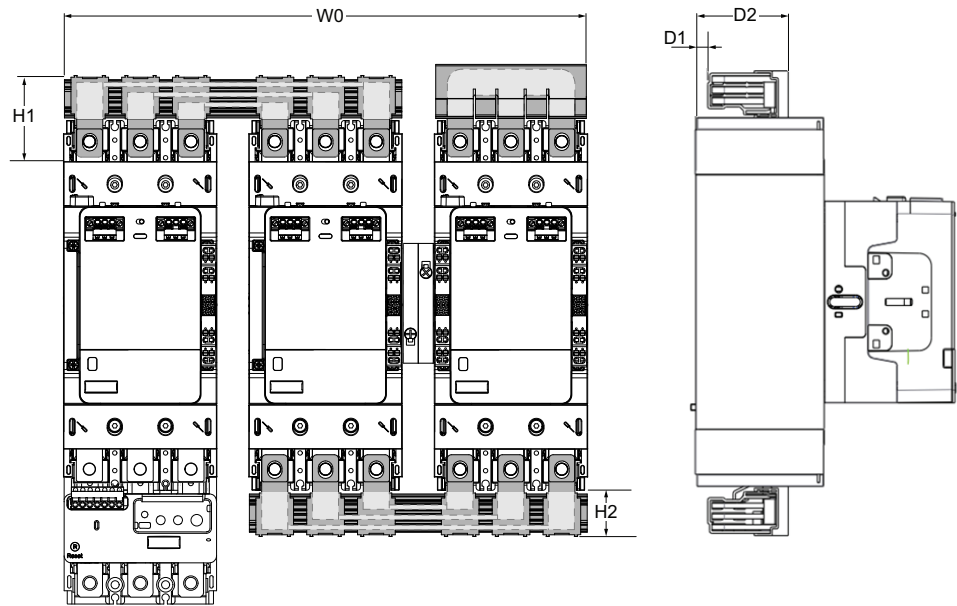

Commercial reference	W0	H1	H2	D1	D2
LA9GQQ330	364 mm (14.33 in.)	31.5 mm (1.24 in.)	31.5 mm (1.24 in.)	23.6 mm (0.92 in.)	68.5 mm (2.69 in.)
LA9GSQ330	428 mm (16.85 in.)	37 mm (1.45 in.)	56.5 mm (2.22 in.)	10 mm (0.39 in.)	75 mm (2.95 in.)
LA9GSS330	460 mm (18.11 in.)	37 mm (1.45 in.)	37 mm (1.45 in.)	10 mm (0.39 in.)	75 mm (2.95 in.)
LA9GTS330	600 mm (23.62 in.)	47.8 mm (1.88 in.)	77.3 mm (3.04 in.)	13.2 mm (0.51 in.)	101 mm (3.97 in.)
LA9GTT330	670 mm (26.37 in.)	47.8 mm (1.88 in.)	47.8 mm 1.88 in.)	13.2 mm (0.51 in.)	101 mm (3.97 in.)
LA9GSQ331	460 mm (18.11 in.)	37 mm (1.45 in.)	56.5 mm (2.22 in.)	10 mm (0.39 in.)	75 mm (2.95 in.)
LA9GTS331	600 mm (23.62 in.)	47.8 mm (1.88 in.)	97 mm (3.81 in.)	13.2 mm (0.51 in.)	101 mm (3.97 in.)

## Power Connection with Star Bar Connection Kit

### Overview

Star bar connection kit is a single star coupling bar to couple the motor stator windings. It is a spare part for the Star-Delta connection kits.

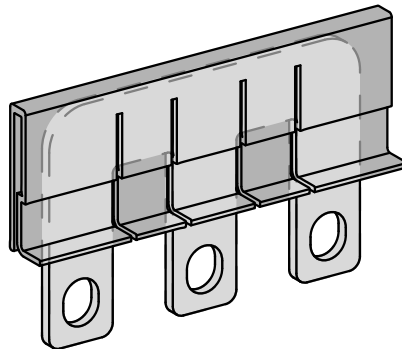

The table below provides the list of the star bar connection kits:

Contactors	Star bar connection kit
LC1G115-225	LA9GQW601
LC1G265-500	LA9GSW601
LC1G630-800	LA9GTW601

### Dimensions

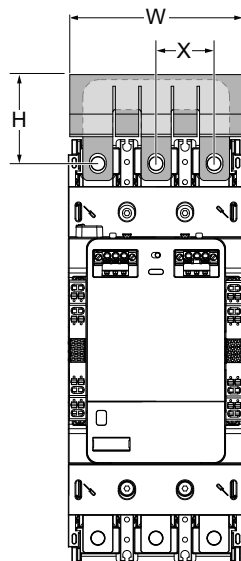

Commercial reference	W	H	X
LA9GQW601	103.7 mm (4.1 in.)	53.25 mm (2.1 in.)	35 mm (1.4 in.)
LA9GSW601	138 mm (5.4 in.)	66.7 mm (2.6 in.)	45mm (1.7 in.)
LA9GTW601	208 mm (8.1 in.)	89 mm (3.5 in.)	70 mm (2.7 in.)

## Power Wiring Diagram

### NOTICE

#### HIGH TRANSIENT CURRENT

Follow scrupulously the wiring diagram and phase sequence.

**Failure to follow can result in high transient current when switching from star to delta connection.**

**Star-delta motor starter with thermal magnetic circuit breaker and contactors**

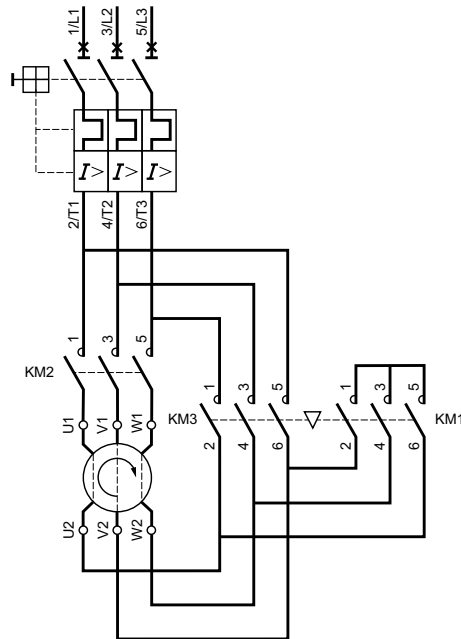

**Star-delta motor starter with magnetic circuit breaker, overload relay, and contactors**

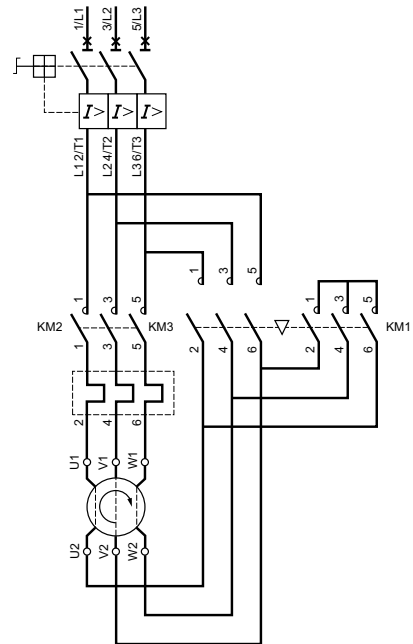

## Installation of the Star-Delta Connection Kits

This section describes the installation procedure of star-delta connection kits on the power terminals of the contactors. Refer to step 9 and 10 for the installation of the star bar connection kit only.

1. Place the line-delta coupling bar beside the upstream power terminals of the line and delta contactors.

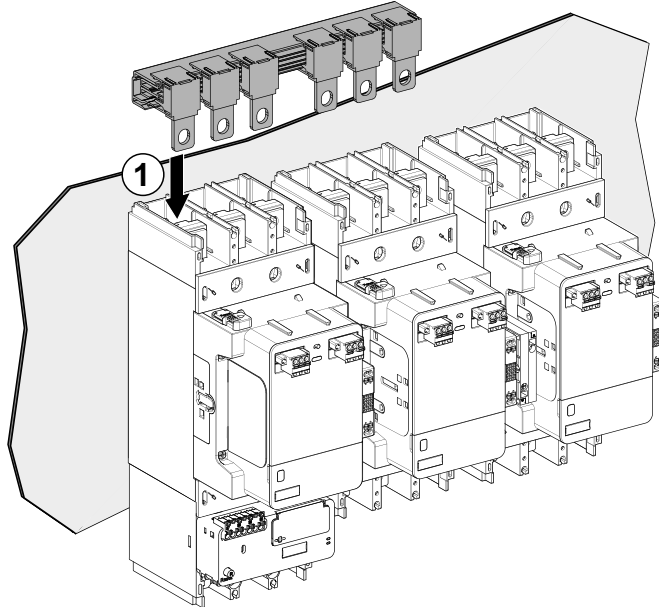

2. Place the bars to connect the line on the upstream power terminals of the line contactor.
3. Insert the screws and washers through the coupling bars and power terminals. Tighten the screws at the right torque.

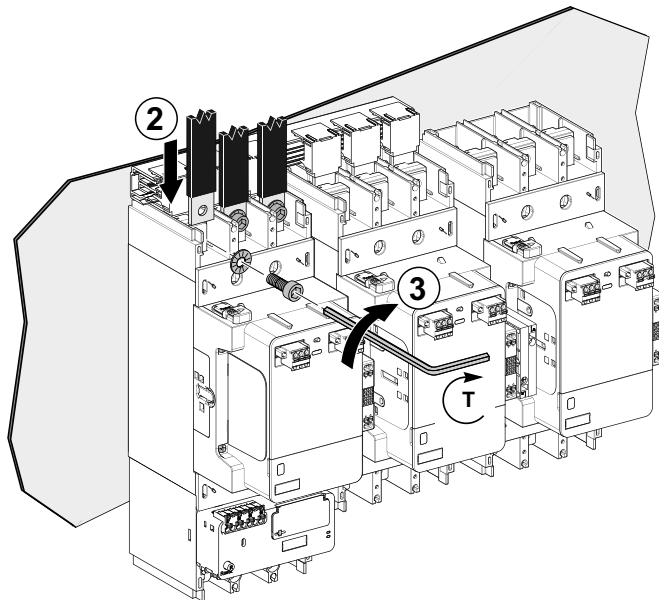

4. Place the bars to connect the motor on the downstream power terminals of the line contactor.
5. Insert the screws and washers through the coupling bars and power terminals. Tighten the screws at the right torque.

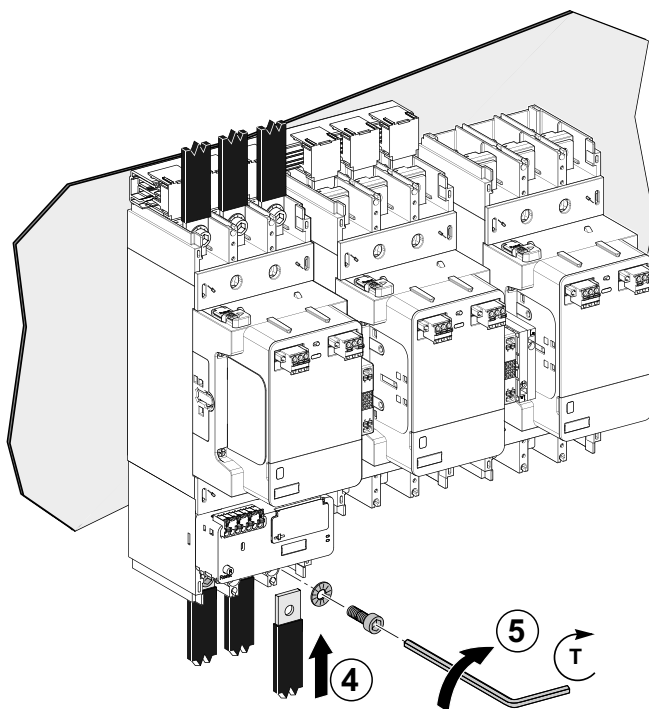

6. Place the star-delta coupling bar beside the downstream power terminals of the star and delta contactors.

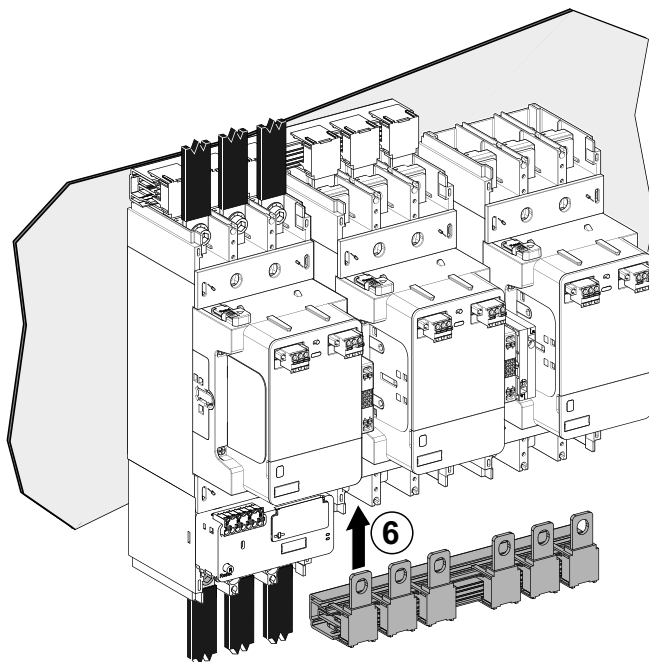

7. Place the bars to connect the motor on the downstream power terminals of the delta contactor.
8. Insert the screws and washers through the coupling bars and power terminals. Tighten the screws at the right torque.

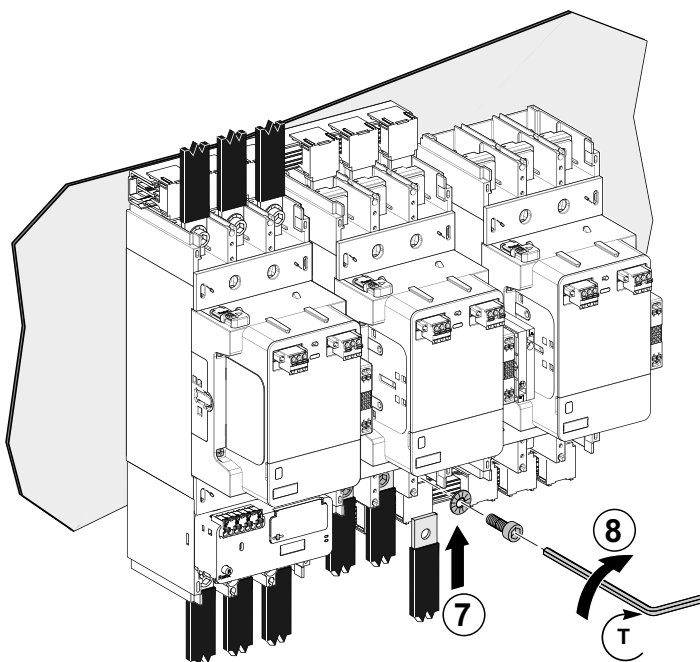

9. Place the star coupling bar beside the upstream power terminals of the star contactor.

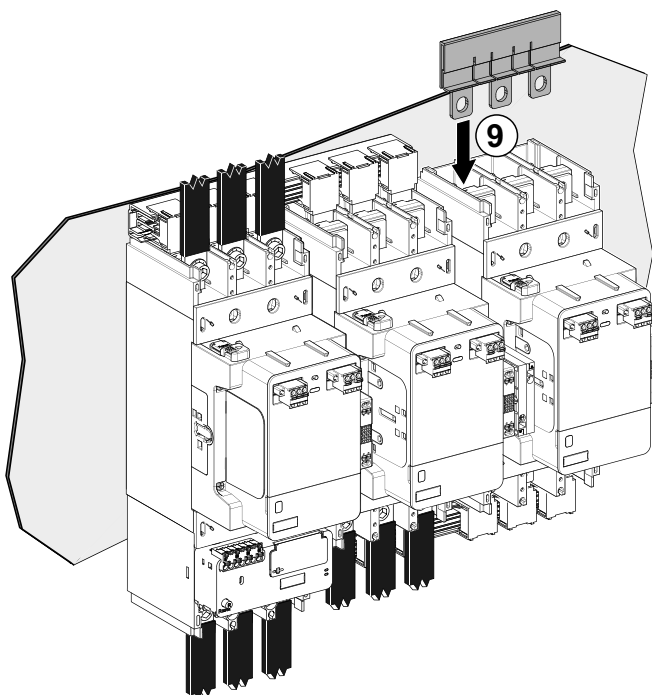

10. Insert the screws and washers through the coupling bars and power terminals. Tighten the screws at the right torque.

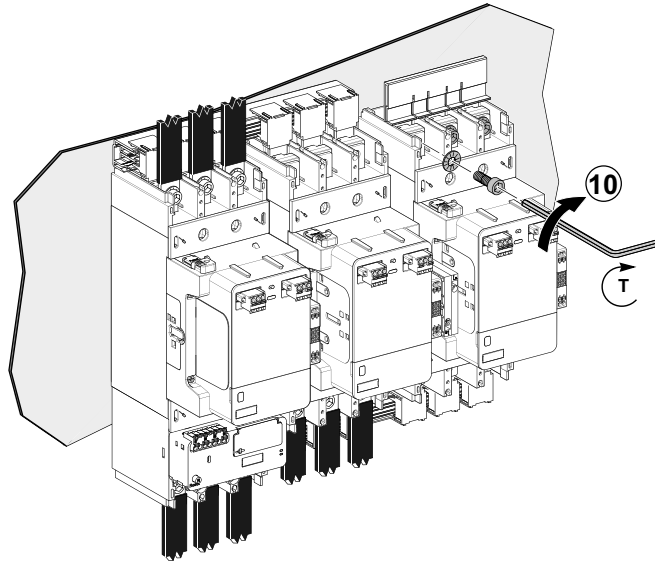

Contactor	Tool	Torque	Screws
LC1G115-225	Allen key	18 ± 1.8 N•m (159 ± 15.9 lb-in)	M8
LC1G265-500	Inner hexagon	35 ± 3.5 N•m (310 ± 31 lb-in)	M10
LC1G630-800	Inner hexagon	58 ± 5.8 N•m (513 ± 51.3 lb-in)	M12

## Control Wiring Diagram

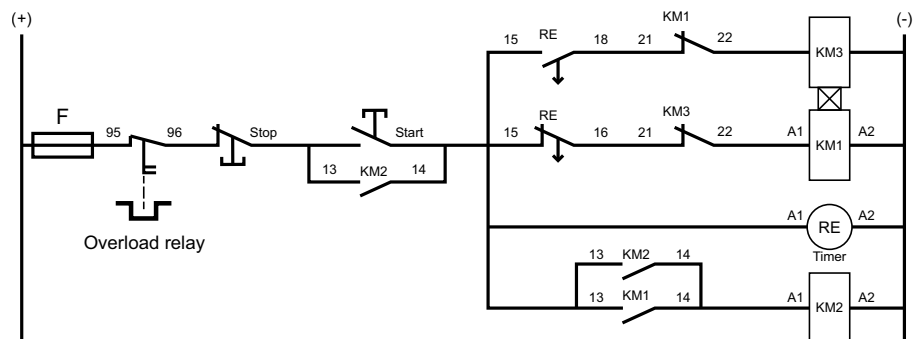

## Timer to Control the Contactors

For the star-delta connection, RE17RMMWS Timer (TMR) can be used to control the contactor up to 250 V.

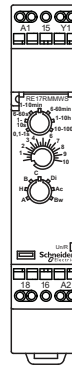

U	12...240 Vdc 1,5 W
U	12...240 Vac 50...60 Hz 3 VA
—	250 Vac / 8 A

# Two Contactors Reverser

## Reverser Application Description

A reverser contactor pair allows the control of a three-phase motor in two directions.

It switches the order of the phases supplying the motor from UVW to UYW:

- Phase rotation is UVW: the motor rotates forward.
- Phase rotation is UYW: the motor rotates reverse.

The two contactors must be mechanically and electrically interlocked to prevent that both contactors are closed in the same time.

## Overload Protection of the Reverser

The thermal overload protection of the motor in a reverser can be provided by a TeSys Giga overload relay. The thermal overload relay rating is the same as the rating of the contactors.

The thermal overload relay can be mounted standalone and connected between the motor stator terminals and the contactors.

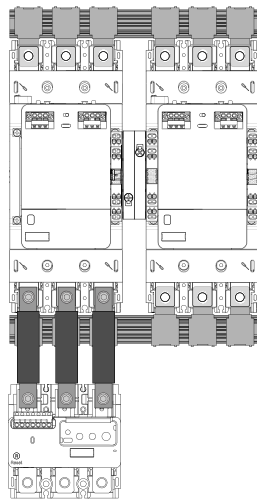

## Reverser Assembly Video

To access a demonstration video about the assembly of two contactors for a reverser application, you can click [here](#), scan the QR code, or copy and paste the link to your Web browser.

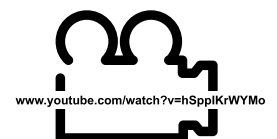
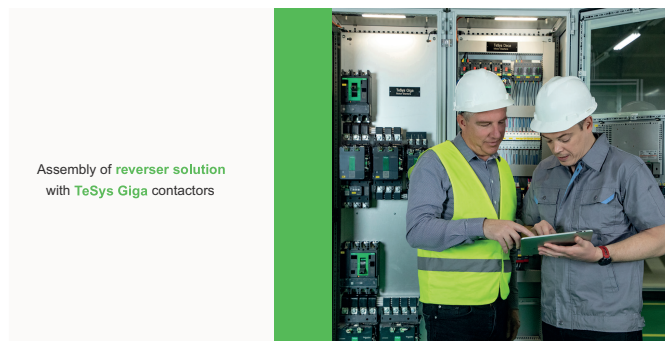

## Mounting Two-Contactor Reverser on Plate

Perform the following procedure to mount a two-contactor reverser with LA9G970 mechanical interlock on the plate.

1. Drill 8 holes in the plate, with respect of the dimensions given.
  - LC1G115-500 - Maximum hole diameter: 6 mm (0.23 in.)
  - LC1G630-800 - Maximum hole diameter: 9 mm (0.35 in.)

**NOTE:** To ease the mounting, drilling stencils JYT1902701 can be downloaded from the [www.se.com](http://www.se.com) website.

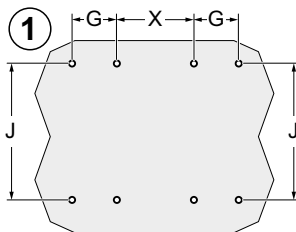

	LC1G115-225	LC1G265-500	LC1G630-800
G	35 mm (1.38 in.)	45 mm (1.77 in.)	70 mm (2.75 in.)
J	166 mm (6.53 in.)	187 mm (7.36 in.)	242 mm (9.52 in.)
X	92.7 mm (3.65 in.)	115 mm (4.53 in.)	160 mm (6.30 in.)

2. Remove the plastic part on the side of the contactor where the mechanical interlock will be installed.
3. Discard the plastic part into the bin.

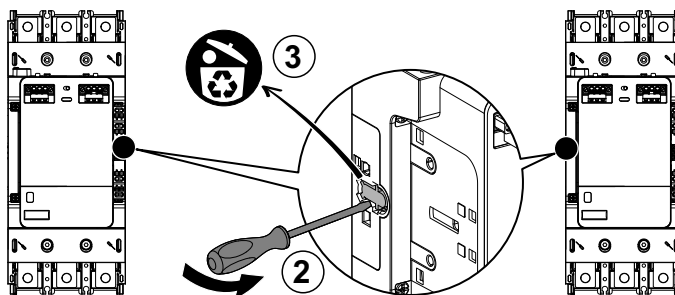

4. Insert the metal slides on the holes of each contactor.

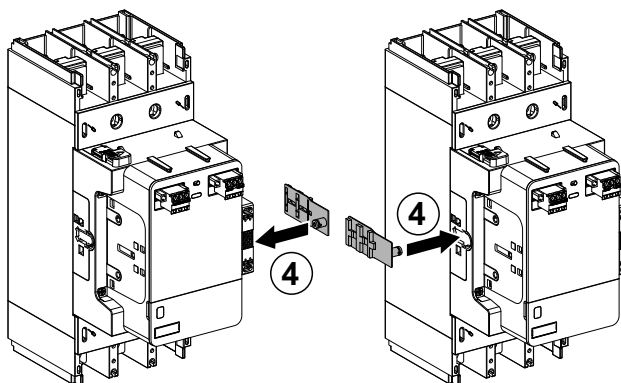

5. Mount each contactor on the plate.

- For mounting LC1G115-225 contactors, see Mounting LC1G115-250 Contactors on Plate, page 75
- For mounting LC1G265-800 contactors, see Mounting LC1G265-500 Contactors on Plate, page 76

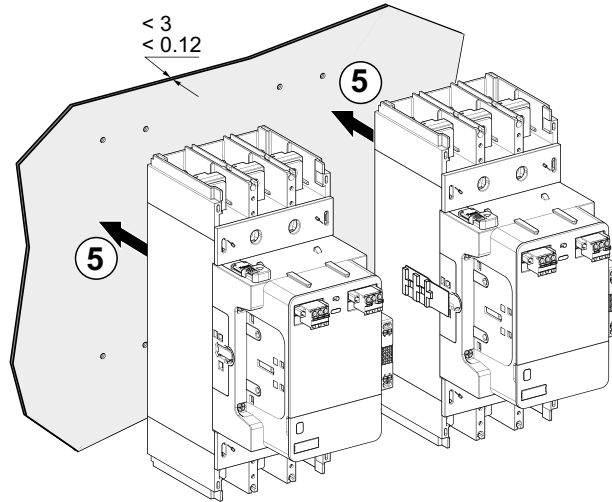

6. Assemble the mechanical interlock according to the rating of the contactors.

	LC1G115-225	LC1G265-500	LC1G630-800
<p><b>LA9G970</b></p>			-
<p><b>LA9G973</b></p>	-		

**NOTE:** To install the mechanical interlock, maximum 1 auxiliary contact is allowed on each side between star and delta contacts.

7. Insert the mechanical interlock between the two contactors on the metal slides.

8. Tighten the two screws at the right torque to lock the interlock.

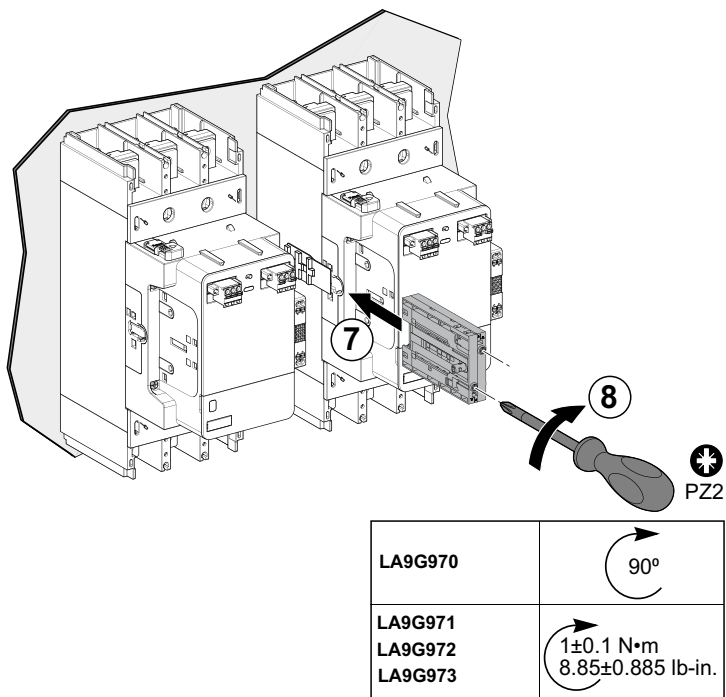

## Power Connection with Reverser Connection Kits

### Overview

Reverser connection kits can be used for the power connection of a 3-pole reverser contactor assembly. These connection kits can be used for contactors with or without cable memory. Check the below table for selection of suitable reverser connection kits.

The top and bottom connection kits are discrete and can't be interchanged.

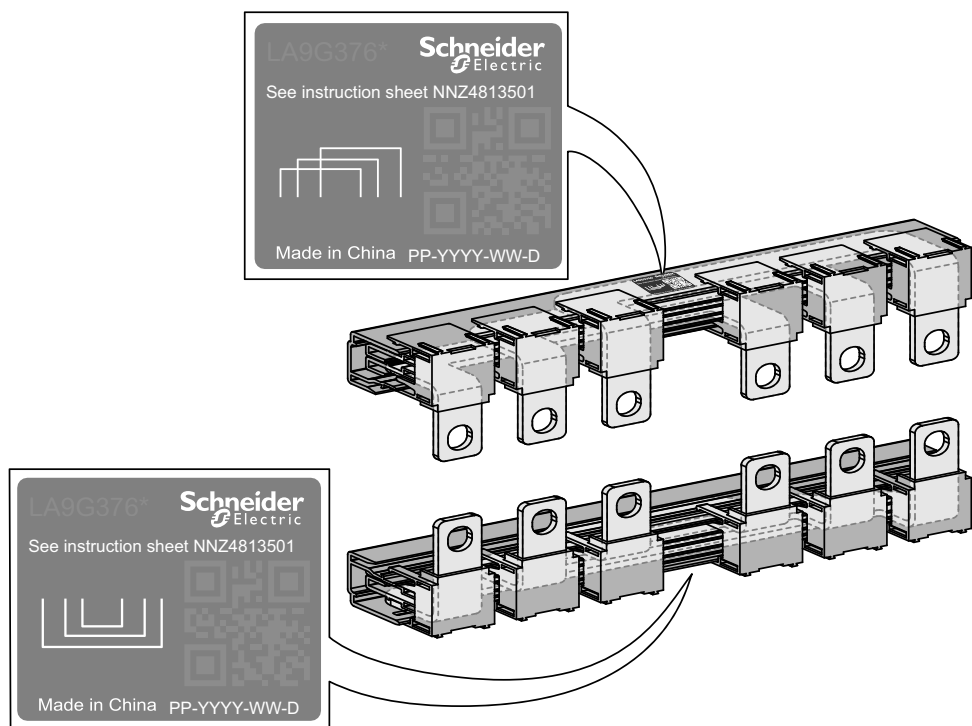

The table below provides the list of the reverser connection kits:

Contactor	Reverser connection kits
LC1G115-225	LA9G3760
LC1G265-500	LA9G3761
LC1G630-800	LA9G3762

## Dimensions

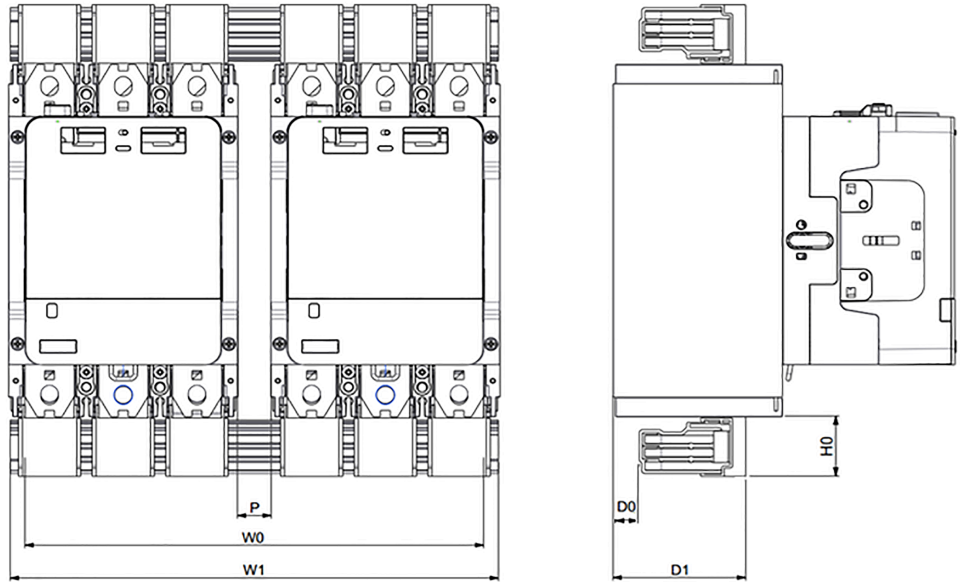

Commercial reference	W0	W1	H0	D0	D1	P
LA9G3760	215.7 mm (8.49 in.)	232.6 mm (9.15 in.)	31.5 mm (1.24 in.)	23.6 mm (0.92 in.)	68.5 mm (2.69 in.)	20 mm (0.78 in.)
LA9G3761	280 mm (11.02 in.)	298 mm (11.73 in.)	38 mm (1.49 in.)	16 mm (0.63 in.)	81 mm (3.18 in.)	20 mm (0.78 in.)
LA9G3762	418.6 mm (16.48 in.)	462.2 mm (18.2 in.)	49 mm (1.93 in.)	29 mm (1.13 in.)	122 mm (4.8 in.)	20 mm (0.78 in.)

## Power Wiring Diagram

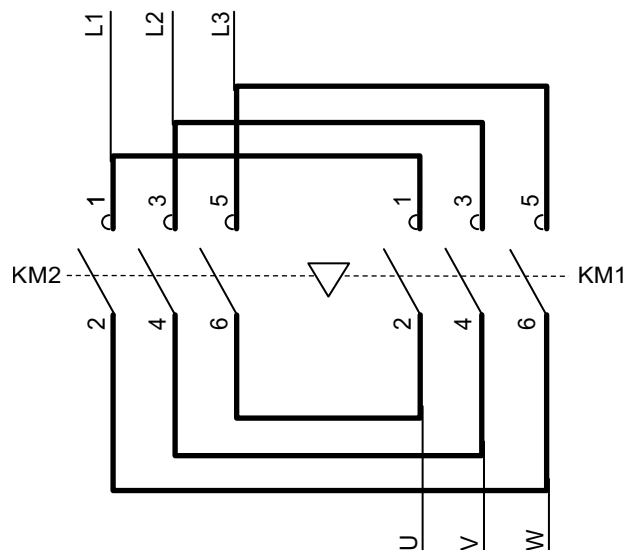

## Installation of the Reverser Connection Kits

This section describes the installation procedure of reverser connection kits on the power terminals of the contactors.

1. Place the coupling bars beside the upstream and downstream power terminals of the contactors.
2. Place the bars to connect the line or the motor on the power terminals of one of the contactors.
3. Insert the screws and washers through the coupling bars and power terminals.
4. Tighten the screws at the right torque.

Contactor	Tool	Torque	Screws
LC1G115-225	Allen key	18 ± 1.8 N•m (159 ± 15.9 lb-in)	M8
LC1G265-500	Inner hexagon	35 ± 3.5 N•m (310 ± 31 lb-in)	M10
LC1G630-800	Inner hexagon	58 ± 5.8 N•m (513 ± 51.3 lb-in)	M12

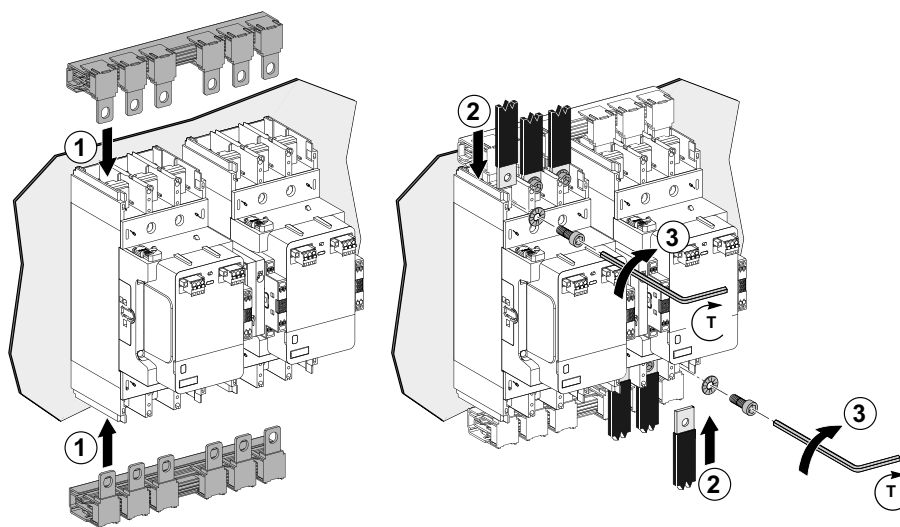

## Control Wiring Diagram with Electrical Interlocking

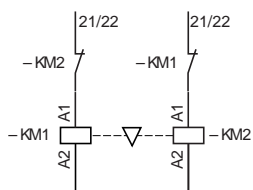

# Two Contactors Changeover

## Changeover Application Description

A changeover contactor pair helps to ensure the continuity of operation of an installation and energy management. It switches between:

- A power supply source M (main) which normally supplies the installation.
- A power supply source S (standby) which can be an incoming line from an additional network or a generating set.

The supply sources are three-phase or three-phase + neutral.

The two contactors must be mechanically and electrically interlocked to prevent any paralleling, even transitory, of the two supplies.

## Changeover Assembly Video

To access a demonstration video about the assembly of two contactors for a changeover application, you can click [here](#), scan the QR code, or copy and paste the link to your Web browser.



## Mounting Two-Contactor Changeover on Plate

Perform the following procedure to mount a two-contactor changeover with LA9G970 mechanical interlock on the plate.

1. Drill 8 holes in the plate, with respect of the dimensions.
  - LC1G115-500 - Maximum hole diameter: 6 mm (0.23 in.)
  - LC1G630-800 - Maximum hole diameter: 9 mm (0.35 in.)

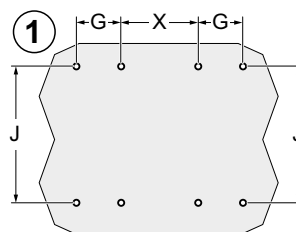

**NOTE:** To ease the mounting, drilling stencils JYT1902701 can be downloaded from the [www.se.com](http://www.se.com) website.

	LC1G115-225		LC1G265-500		LC1G630-800	
	3P	4P	3P	4P	3P	4P
G	35 mm (1.38 in.)	70 mm (2.75 in.)	45 mm (1.77 in.)	90 mm (3.54 in.)	70 mm (2.75 in.)	140 mm (5.51 in.)
J	166 mm (6.53 in.)	166 mm (6.53 in.)	187 mm (7.36 in.)	187 mm (7.36 in.)	242 mm (9.52 in.)	242 mm (9.52 in.)
X	92.7 mm (3.65 in.)	92.7 mm (3.65 in.)	115 mm (4.53 in.)	115 mm (4.53 in.)	160 mm (6.30 in.)	160 mm (6.30 in.)

2. Remove the plastic part on the side of the contactor where the mechanical interlock will be installed.
3. Discard the plastic part into the bin.

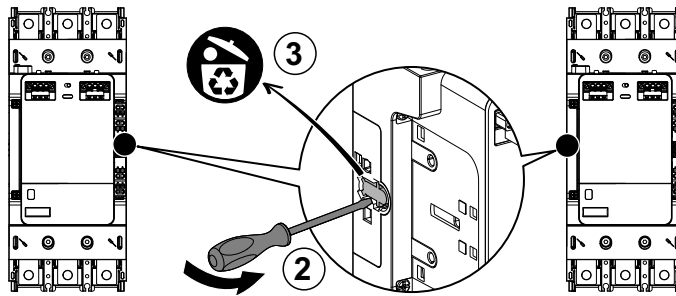

4. Insert the metal slides on the holes of each contactor.

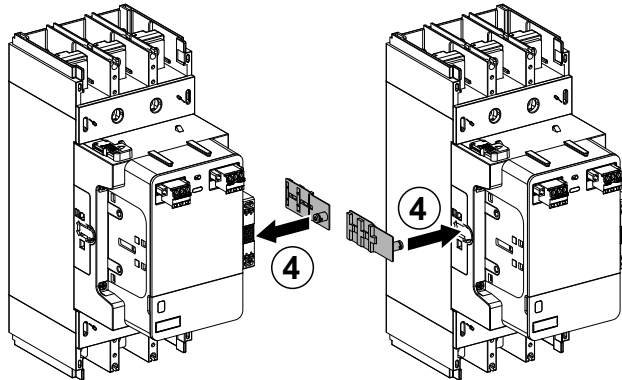

5. Mount each contactor on the plate.
  - For mounting LC1G115-225 contactors, see [Mounting LC1G115-250 Contactors on Plate](#), page 75
  - For mounting LC1G265-800 contactors, see [Mounting LC1G265-500 Contactors on Plate](#), page 76

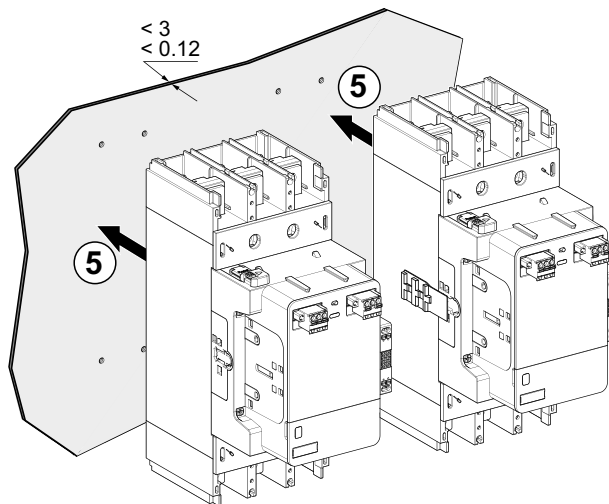

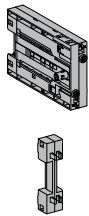
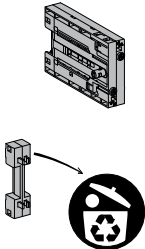
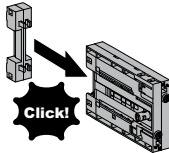
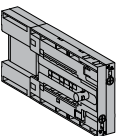
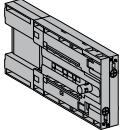

6. Assemble the mechanical interlock according to the rating of the contactors.

	LC1G115–225	LC1G265–500	LC1G630–800
<b>LA9G970</b> 			-
<b>LA9G973</b> 	-	-	

**NOTE:** To install the mechanical interlock, maximum 1 auxiliary contact is allowed on each side between star and delta contacts.

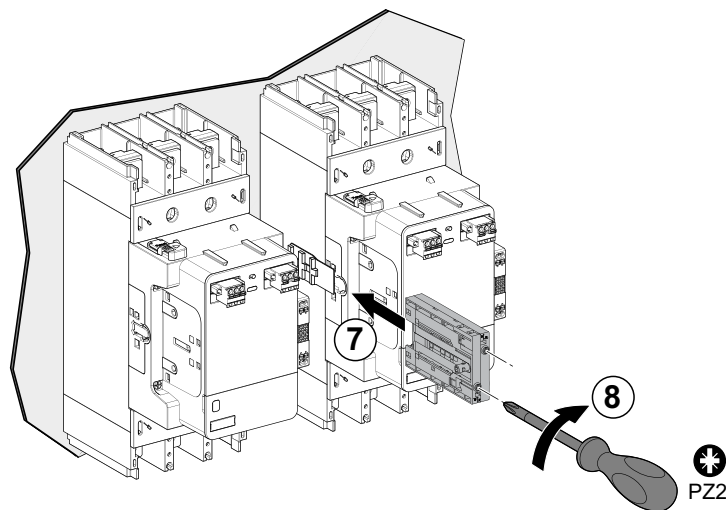
7. Insert the mechanical interlock between the two contactors on the metal slides.
8. Tighten the two screws at the right torque to lock the interlock.

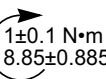

LA9G970	 90°
LA9G971 LA9G972 LA9G973	 1±0.1 N•m 8.85±0.885 lb-in.

## Power Connection with Changeover Connection Kits

### Overview

Changeover connection kits can be used for the power connection of 3-pole or 4-pole two-contactor changeover. If using the connection kits, the two contactors must be fitted with a cable memory or must be without cable memory. This connection can be done only downstream of the contactors.

Changeover connection kits are made of one coupling bar.

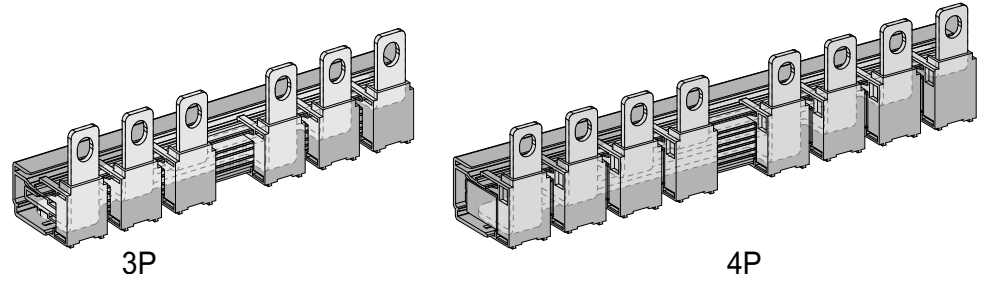

The table below provides the list of the changeover connection kits:

Contactor	Number of poles	Changeover connection kits
LC1G115-225	3P	LA9G3750
	4P	LA9G4750
LC1G265-500	3P	LA9G3751
	4P	LA9G4751
LC1G630-800	3P	LA9G3752
	4P	LA9G4752

## Dimensions

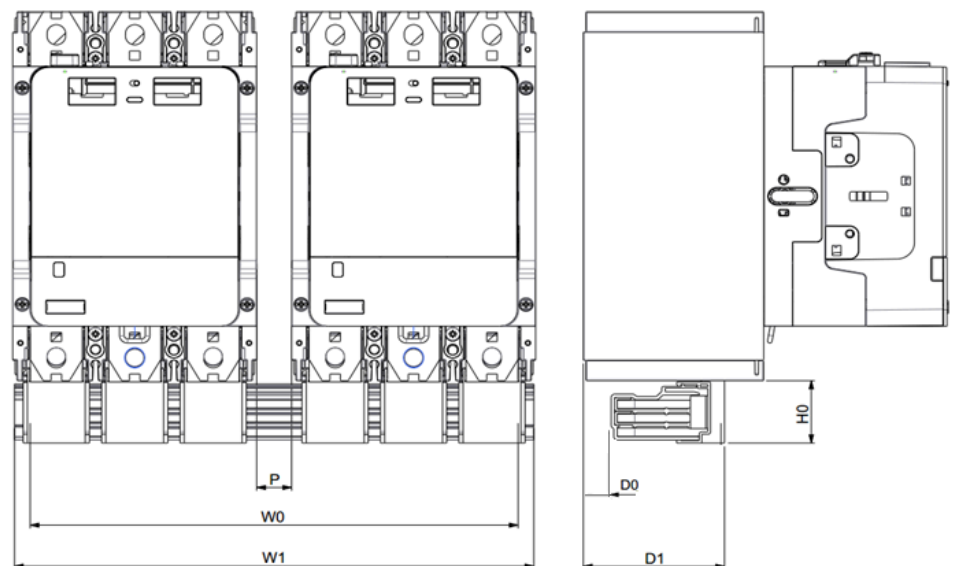

Commercial reference	W0	W1	H0	D0	D1	P
LA9G3750	215.7 mm (8.49 in.)	232.6 mm (9.15 in.)	31.5 mm (1.24 in.)	23.6 mm (0.92 in.)	68.5 mm (2.69 in.)	20 mm (0.78 in.)
LA9G4750	286 mm (11.25 in.)	303 mm (11.92 in.)	39 mm (1.54 in.)	23.6 mm (0.92 in.)	68.5 mm (2.69 in.)	20 mm (0.78 in.)
LA9G3751	280 mm (11.02 in.)	298 mm (11.73 in.)	38 mm (1.49 in.)	16 mm (0.63 in.)	81 mm (3.18 in.)	20 mm (0.78 in.)
LA9G4751	370 mm (14.56 in.)	388 mm (15.27 in.)	49 mm (1.93 in.)	16 mm (0.631 in.)	81 mm (3.18 in.)	20 mm (0.78 in.)
LA9G3752	418.6 mm (16.48 in.)	462.2 mm (18.2 in.)	49 mm (1.49 in.)	29 mm (1.93 in.)	122 mm (4.8 in.)	20 mm (0.78 in.)
LA9G4752	558.6 mm (21.99 in.)	581.2 mm (22.88 in.)	61.5 mm (2.42 in.)	29 mm (1.93 in.)	122 mm (4.8 in.)	20 mm (0.78 in.)

# Power Wiring Diagram

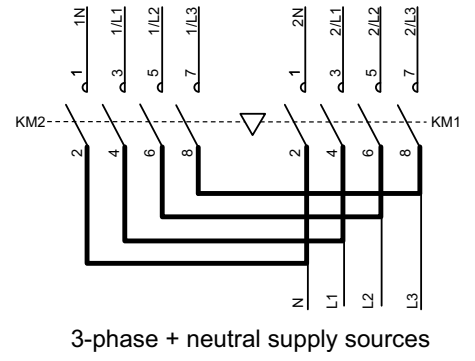
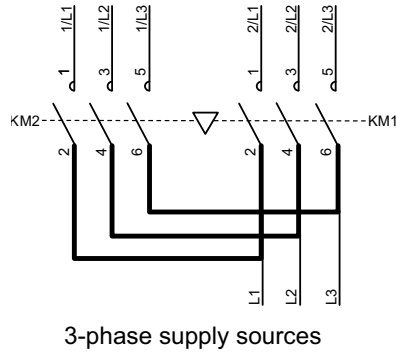

## Installation of the Changeover Connection Kits

This section describes the installation procedure of changeover connection kits on the power terminals of the contactors.

1. Place the coupling bar beside the downstream power terminals of the contactors.
2. Place the bars to connect the line on the downstream power terminals of one of the contactors.
3. Insert the screws and washers through the coupling bar and power terminals.
4. Tighten the screws at the right torque.

Contactactor	Tool	Torque	Screws
LC1G115-225	Allen key	18 ± 1.8 N•m (159 ± 15.9 lb-in)	M8
LC1G265-500	Inner hexagon	35 ± 3.5 N•m (310 ± 31 lb-in)	M10
LC1G630-800	Inner hexagon	58 ± 5.8 N•m (513 ± 51.3 lb-in)	M12

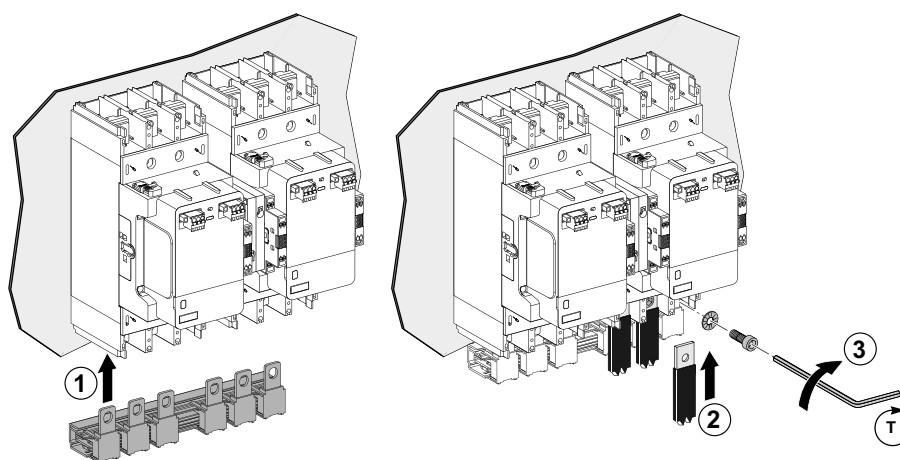

## Control Wiring Diagram with Electrical Interlocking

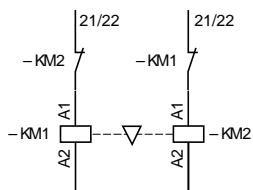

# Maintenance

## What's in This Chapter

Safety Instructions.....	191
Switching Module Replacement.....	192
Control Module Replacement.....	201

## Safety Instructions

### **DANGER**

#### **HAZARD OF ELECTRIC SHOCK, EXPLOSION, OR ARC FLASH**

- Apply appropriate personal protective equipment (PPE) and follow safe electrical work practices. See NFPA 70E, CSA Z462, NOM 029-STPS or local equivalent.
- This equipment must only be installed and serviced by qualified electrical personnel.
- Turn off all power supplying this equipment before working on this equipment.
- Use only the specified voltage when operating this equipment and any associated products.
- Power line circuits must be wired and protected in compliance with local and national regulatory requirements.
- Beware of potential hazards, and carefully inspect the work area for tools and objects that may have been left inside the equipment.

**Failure to follow these instructions will result in death or serious injury.**

# Switching Module Replacement

## Overview

Based on contact wear or as needed, the switching modules can be replaced. The switching modules must be replaced when the contact wear diagnosis function has detected that the contacts are worn. When the contacts are worn, all switching modules must be replaced together.

The switching modules are compatible with advanced and standard contactors.

The table below provides the commercial references of the switching modules:

Contactor	Set of 3 switching modules for 3P contactor	Set of 4 switching modules for 4P contactors
LC1G115–225	LA9G3QA	LA9G4QA
LC1G265–330	LA9G3RA	LA9G4RA
LC1G400–500	LA9G3SA	LA9G4SA
LC1G630–800	LA9G3TA	LA9G4TA

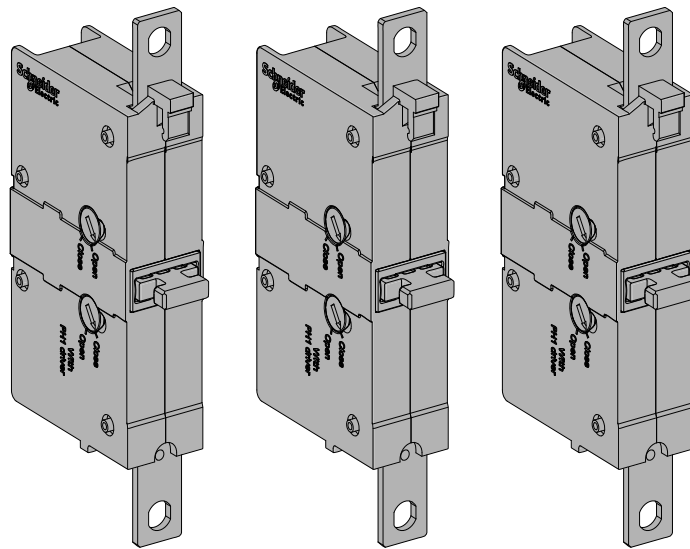

## Switching Module Replacement Video

To access a demonstration video about replacing the switching modules on a contactor, you can click [here](#), scan the QR code, or copy and paste the link to your Web browser.



[www.youtube.com/watch?v=vFCWMN5IxeU](https://www.youtube.com/watch?v=vFCWMN5IxeU)

## Removal of Contactor with Cable Memory

The switching modules of advanced contactors or standard contactors with cable memory can be replaced without power disconnection.

Before replacing the switching modules on a contactor with cable memory:

- Remove the mechanical interlock, if present.
- Remove all auxiliary contact modules.

Perform the following procedure to remove the contactor with cable memory:

1. Unscrew the control terminal blocks.
2. Remove the control terminal blocks.
3. Remove internal power connection screws cover.
4. Unscrew with the right tool to remove the internal power connection screws.
5. Unscrew with an Allen key the four screws fixing the contactor block in the contactor housing.
6. Remove the contactor block from the contactor housing.

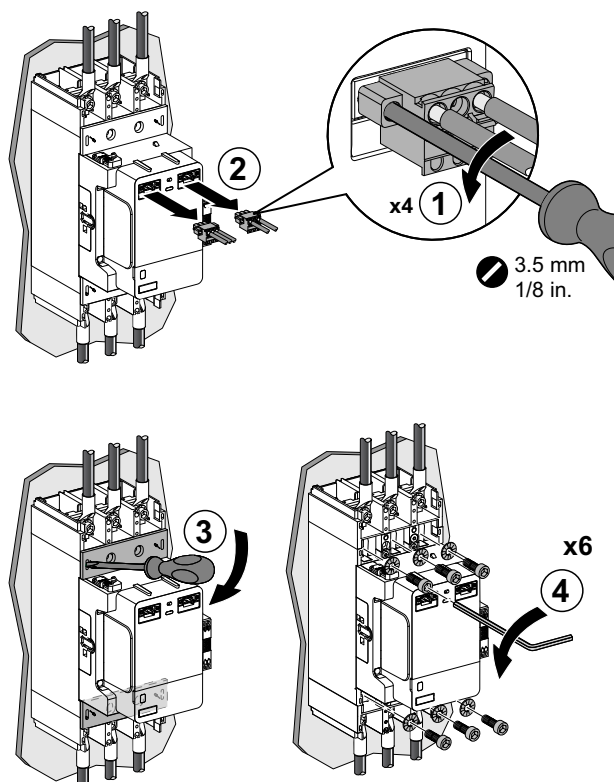

Contactor	Tool	Screws
LC1G115-225	Allen key	M8
LC1G265-500	Inner hexagon	M10
LC1G630-800	Inner hexagon	M12

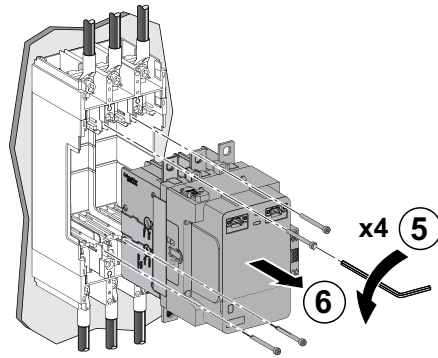

Contactor	Tool	Length of Allen Key (L)	Screws
LC1G115-225	Allen key	≥ 95 mm (≥ 3.74 in.)	M4
LC1G265-500	Allen key	≥ 115 mm (≥ 4.52 in.)	M4
LC1G630-800	Allen key	≥ 115 mm (≥ 4.52 in.)	M6

## Removal of Contactor without Cable Memory

Before replacing the switching modules on a contactor without cable memory:

- Remove the mechanical interlock and coupling bars, if present.
- Remove all auxiliary contact modules.
- Disconnect top and bottom power connections.

Perform the following procedure to remove the contactor without cable memory:

1. Unscrew the control terminal blocks.
2. Remove the control terminal blocks.
3. Disconnect the top and bottom power connections.
4. Free the contactor from the power conductors.
5. Unscrew with an Allen key the 4 screws fixing the contactor block in the contactor housing.
6. Remove the contactor block from the contactor housing.

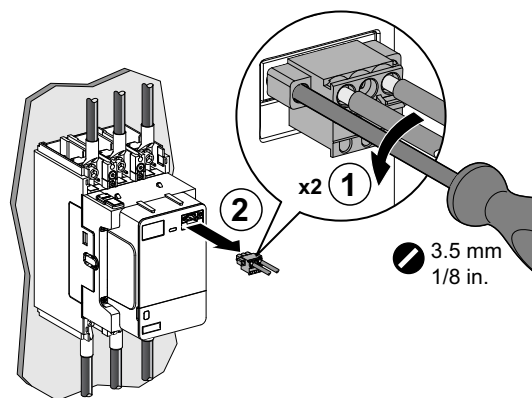

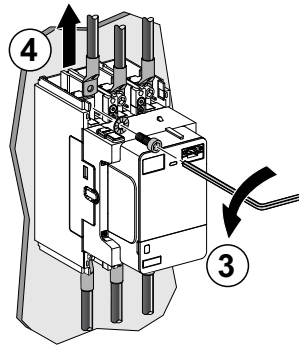

Contactor	Tool	Screws
LC1G115-225	Allen key	M8
LC1G265-500	Inner hexagon	M10
LC1G630-800	Inner hexagon	M12

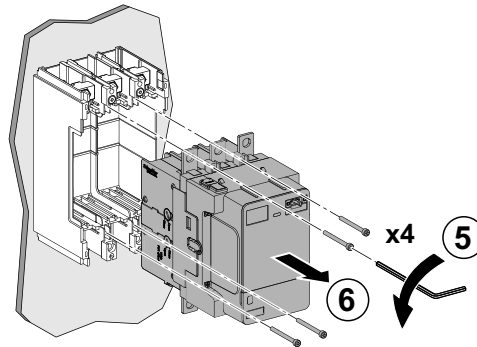

Contactor	Tool	Length of Allen Key (L)	Screws
LC1G115-225	Allen key	≥ 95 mm (≥ 3.74 in.)	M4
LC1G265-500	Allen key	≥ 115 mm (≥ 4.52 in.)	M4
LC1G630-800	Allen key	≥ 115 mm (≥ 4.52 in.)	M6

## Switching Module Replacement

1. Open the flip cover under the control module.
2. Release the switching modules screws (one screw per switching module) using an Allen key.
3. Push up the switching module to unlock and remove it.

**NOTE:** Clean the accessible parts of the contactor and visually check the overall condition of the contactor.

4. Recycle the switching modules.
5. Take out the new switching modules from the box for replacement.
6. Push down the switching modules to lock it on the contactor.
7. Tighten the switching modules screws (one screw per switching module) at the right torque.
8. Put the flip cover back on the control module.
9. Reset the wear diagnosis indication.

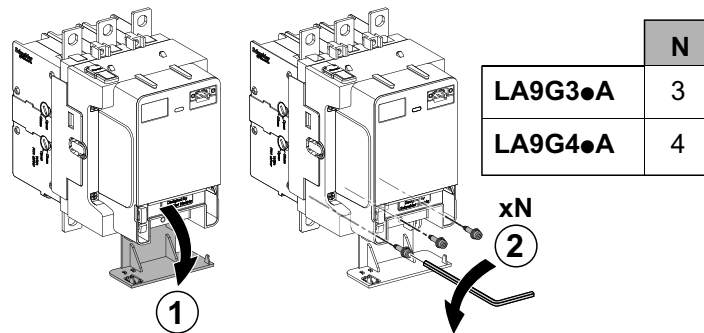

Contactor	Tool	Length of Allen Key (L)	Torque	Screws
LC1G115-225	Allen key	≥ 95 mm (≥ 3.74 in.)	0.8 ± 0.08 N•m (7 ± 0.7 lb-in)	M4
LC1G265-500	Allen key	≥ 115 mm (≥ 4.52 in.)	1 ± 0.1 N•m (8.8 ± 0.88 lb-in)	M4
LC1G630-800	Allen key	≥ 115 mm (≥ 4.52 in.)	3 ± 0.3 N•m (26.5 ± 2.65 lb-in)	M6

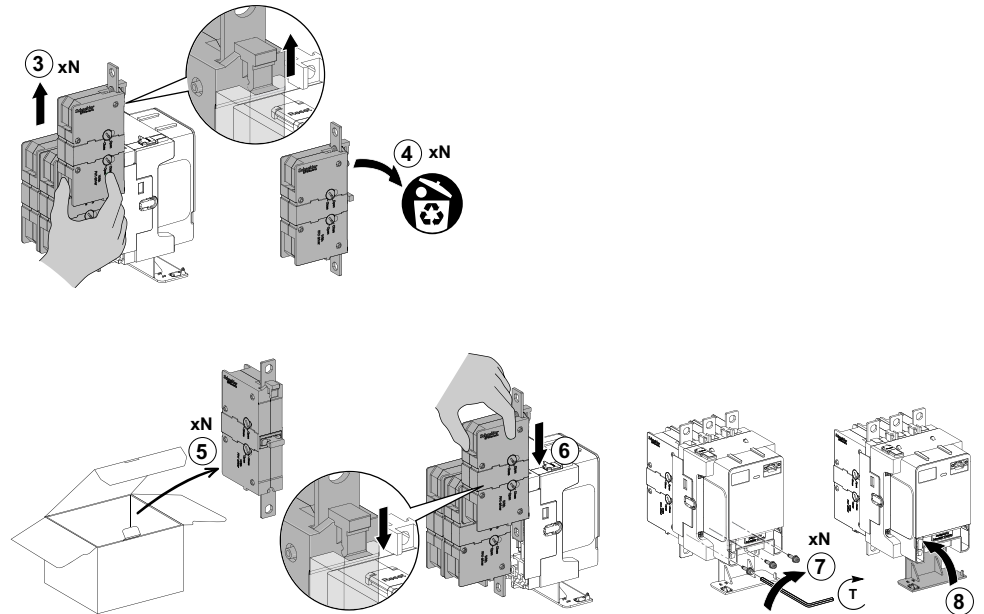

## Wear Diagnosis Reset

### Without Remote Wear Diagnosis Module

To reset the wear diagnosis indication after replacement of the switching modules on contactors without remote wear diagnosis module:

1. Open the cover of the **Reset** switch
2. Change the position of the **Reset** switch on the contactor (from A to B or from B to A).

After reset and after power on A1-A2, the contactor is in reset sequence for 10 s: the diagnosis LED is blinking, and the contactor remains open. It closes after the 10 s.

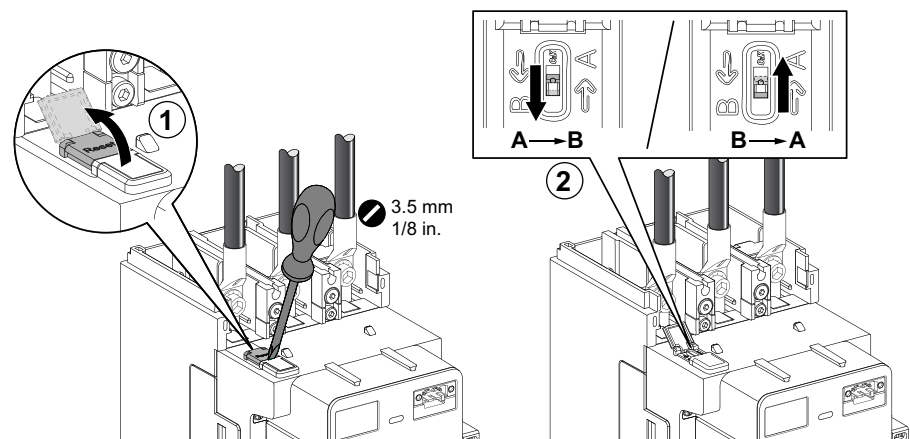

## With Remote Wear Diagnosis Module

On advanced contactors with optional remote wear diagnosis module, the wear diagnosis indication must be reset on remote wear diagnosis module.

After wear detection, the **Reset** button on the remote wear diagnosis module is on the right.

To reset the wear diagnosis indication after replacement of the switching modules, switch the **Reset** button to the left.

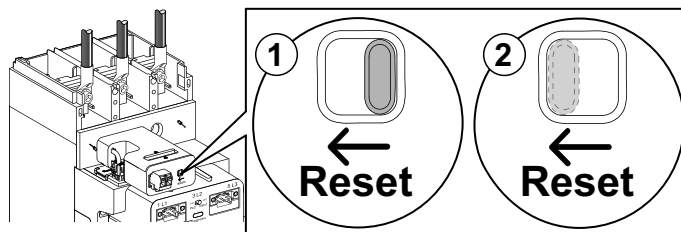

After reset and after power on A1-A2, the contactor is in reset sequence for 10 s: the diagnosis LED is blinking, and the contactor remains open. It closes after the 10 s.

## Re-installation of Contactor with Cable Memory

1. Insert the contactor block in the contactor housing.
2. Tighten the four screws fixing the contactor block in the contactor housing with an Allen key at the right torque.
3. Tighten the internal power connection at the right torque.
4. Put back the internal power connection cover.
5. Put back the control terminal blocks.
6. Tighten the control terminal blocks at the right torque.
7. Put back the auxiliary contact modules.
8. Put back the mechanical interlock, if necessary.

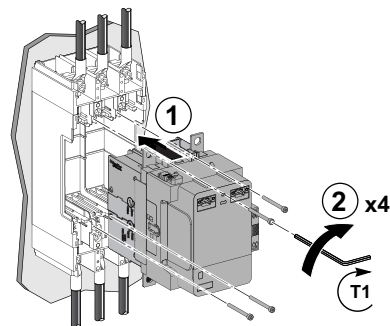

Contactor	Tool	Length of Allen Key (L)	Torque	Screws
LC1G115-225	Allen key	≥ 95 mm (≥ 3.74 in.)	1.5 ± 0.5 N•m (13.2 ± 4.42 lb-in)	M4
LC1G265-500	Allen key	≥ 115 mm (≥ 4.52 in.)	1.5 ± 0.5 N•m (13.2 ± 4.42 lb-in)	M4
LC1G630-800	Allen key	≥ 115 mm (≥ 4.52 in.)	3 ± 0.3 N•m (26.5 ± 2.65 lb-in)	M6

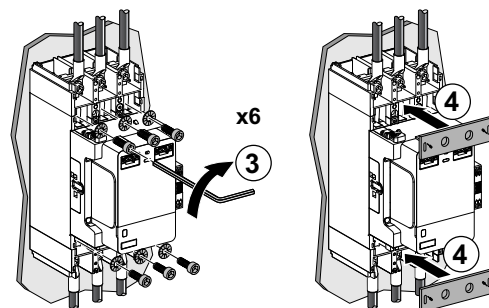

Contactor	Tool	Torque	Screws
LC1G115-225	Allen key	18 ± 1.8 N•m (159 ± 15.9 lb-in)	M8
LC1G265-500	Inner hexagon	35 ± 3.5 N•m (310 ± 31 lb-in)	M10
LC1G630-800	Inner hexagon	58 ± 5.8 N•m (513 ± 51.3 lb-in)	M12

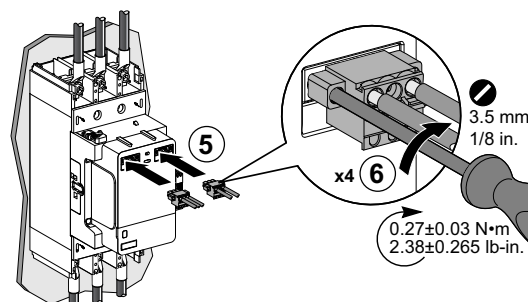

## Re-installation of Contactor without Cable Memory

1. Insert the contactor block in the contactor housing.
2. Tighten the four screws fixing the contactor block in the contactor housing with an Allen key at the right torque.
3. Place the power conductors on the power terminals of the contactor.
4. Re-connect the top and bottom power connections at the right torque.
5. Put back the control terminal blocks.
6. Tighten the control terminal blocks at the right torque.
7. Put back the auxiliary contact modules.
8. Put back the mechanical interlock and coupling bars, if necessary.

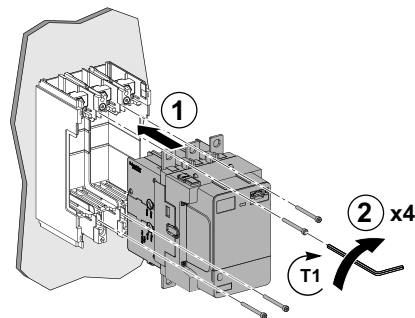

Contactor	Tool	Length of Allen Key (L)	Torque	Screws
LC1G115-225	Allen key	$\geq 95 \text{ mm}$ ( $\geq 3.74 \text{ in.}$ )	$1.5 \pm 0.5 \text{ N}\cdot\text{m}$ ( $13.2 \pm 4.42 \text{ lb-in}$ )	M4
LC1G265-500	Allen key	$\geq 115 \text{ mm}$ ( $\geq 4.52 \text{ in.}$ )	$1.5 \pm 0.5 \text{ N}\cdot\text{m}$ ( $13.2 \pm 4.42 \text{ lb-in}$ )	M4
LC1G630-800	Allen key	$\geq 115 \text{ mm}$ ( $\geq 4.52 \text{ in.}$ )	$3 \pm 0.3 \text{ N}\cdot\text{m}$ ( $26.5 \pm 2.65 \text{ lb-in}$ )	M6

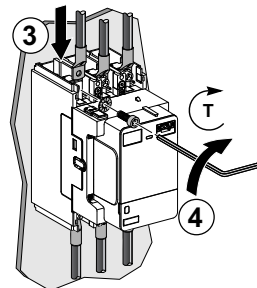

Contactor	Tool	Torque	Screws
LC1G115-225	Allen key	$18 \pm 1.8 \text{ N}\cdot\text{m}$ ( $159 \pm 15.9 \text{ lb-in}$ )	M8
LC1G265-500	Inner hexagon	$35 \pm 3.5 \text{ N}\cdot\text{m}$ ( $310 \pm 31 \text{ lb-in}$ )	M10
LC1G630-800	Inner hexagon	$58 \pm 5.8 \text{ N}\cdot\text{m}$ ( $513 \pm 51.3 \text{ lb-in}$ )	M12

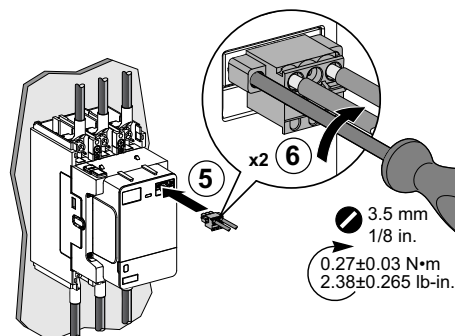

# Control Module Replacement

## Overview

The control module contains the components required to control the contactor poles:

- A fixed magnetic circuit
- a coil winding
- an electronic board

There are two types of the control modules:

- Advanced control module
- Standard control module

The control module can be replaced by a spare control module after detection of an internal malfunction.

## Advanced Control Module

The table below provides the commercial references of the advanced control modules:

Contactor	Control voltage	3P control module	4P control module
LC1G115–225	24–48 Vac/Vdc	LX1G3QBEEA	LX1G4QBEEA
	48–130 Vac/Vdc	LX1G3QEHEA	LX1G4QEHEA
	200–500 Vac/Vdc	LX1G3QLSEA	LX1G4QLSEA
LC1G265–330	24–48 Vac/Vdc	LX1G3RBEEA	LX1G4RBEEA
	48–130 Vac/Vdc	LX1G3REHEA	LX1G4REHEA
	200–500 Vac/Vdc	LX1G3RLSEA	LX1G4RLSEA
LC1G400–500	24–48 Vac/Vdc	LX1G3SBEEA	LX1G4SBEEA
	48–130 Vac/Vdc	LX1G3SEHEA	LX1G4SEHEA
	200–500 Vac/Vdc	LX1G3SLSEA	LX1G4SLSEA
LC1G630–800	48–130 Vac/Vdc	LX1G3TEHEA	LX1G4TEHEA
	200–500 Vac/Vdc	LX1G3TLSEA	LX1G4TLSEA

## Standard Control Module

The table below provides the commercial references of the standard control modules:

Contactor	Control voltage	3P control module	4P control module
LC1G115–225	48–130 Vac/Vdc	LX1G3QEHEH	LX1G4QEHEH
	100–250 Vac/Vdc	LX1G3QKUEN	LX1G4QKUEN
	200–500 Vac/Vdc	LX1G3QLSEMN	-
LC1G265–330	48–130 Vac/Vdc	LX1G3REHEH	LX1G4REHEH
	100–250 Vac/Vdc	LX1G3RKUEN	LX1G4RKUEN
	200–500 Vac/Vdc	LX1G3RLSEMN	-
LC1G400–500	48–130 Vac/Vdc	LX1G3SEHEH	LX1G4SEHEH
	100–250 Vac/Vdc	LX1G3SKUEN	LX1G4SKUEN
	200–500 Vac/Vdc	LX1G3SLSEMN	-
LC1G630–800	48–130 Vac/Vdc	LX1G3TEHEH	LX1G4TEHEH
	100–250 Vac/Vdc	LX1G3TKUEN	LX1G4TKUEN
	200–500 Vac/Vdc	LX1G3TLSEMN	-

## Control Module Replacement Video

To access a demonstration video about replacing the control module on a contactor, you can click [here](#), scan the QR code, or copy and paste the link to your Web browser.

Replace **Control Modules** on  
TeSys Giga contactor





[www.youtube.com/watch?v=pE7waP6SFrg](https://www.youtube.com/watch?v=pE7waP6SFrg)

## Control Module Removal

The control module can be replaced without power disconnection.

Before replacing the control module on a contactor:

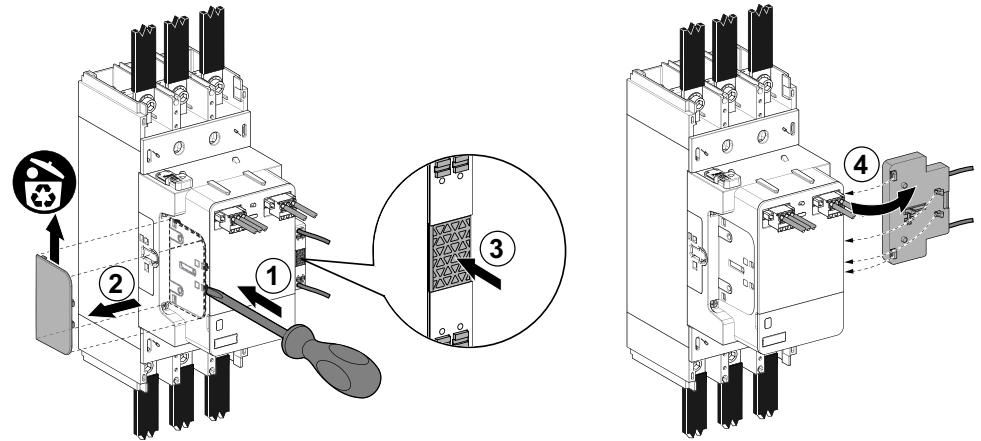
- Remove the plate on the side of the control module, if present
- Remove all auxiliary contact modules.
- On advanced control module, note the position of the **PLC Input** switch



Perform the following procedure to remove the control module:

1. Unscrew the control terminal blocks.
2. Remove the control terminal blocks.
3. Open the flip cover under the control module.
4. Push on the screws fixing the control module on the contactor with a screwdriver.
5. Turn the screws 90° anti-clockwise to unlock the control module.
6. Remove the control module from the contactor.
7. Recycle the control module.

**NOTE:** Clean the accessible parts of the contactor and visually check the overall condition of the contactor.

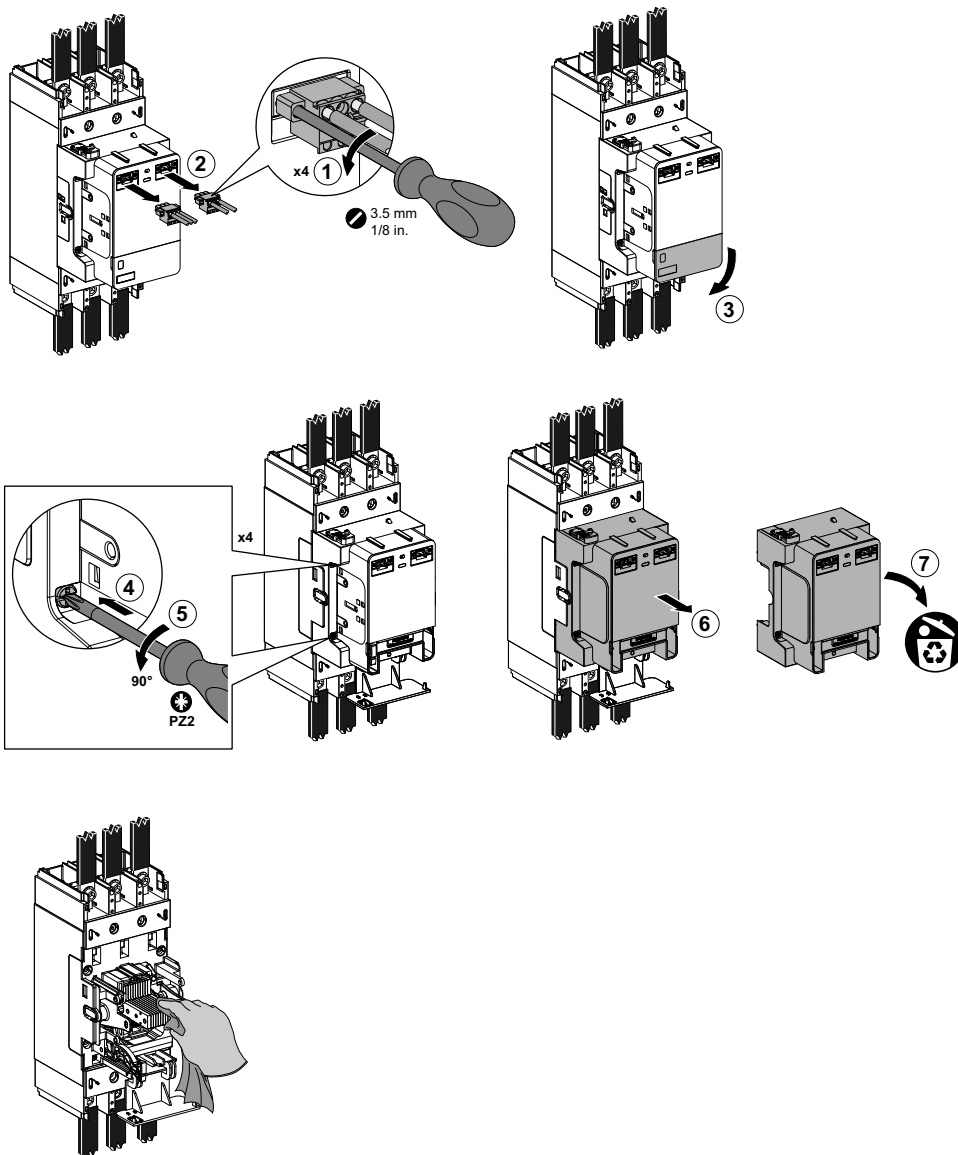

## Control Module Replacement

1. Take out the new control module from the box for replacement.
2. Insert the control module on the contactor.
3. Push on the screws fixing the control module on the contactor with a screwdriver.
4. Turn the screws 90° clockwise to lock the control module.
5. Put the flip cover back on the control module.
6. Put back the control terminal blocks.
7. Tighten the control terminal blocks at the right torque.
8. Put back the auxiliary contact modules.
9. On advanced control module, set the **PLC Input** switch in the same position as on the removed control module.

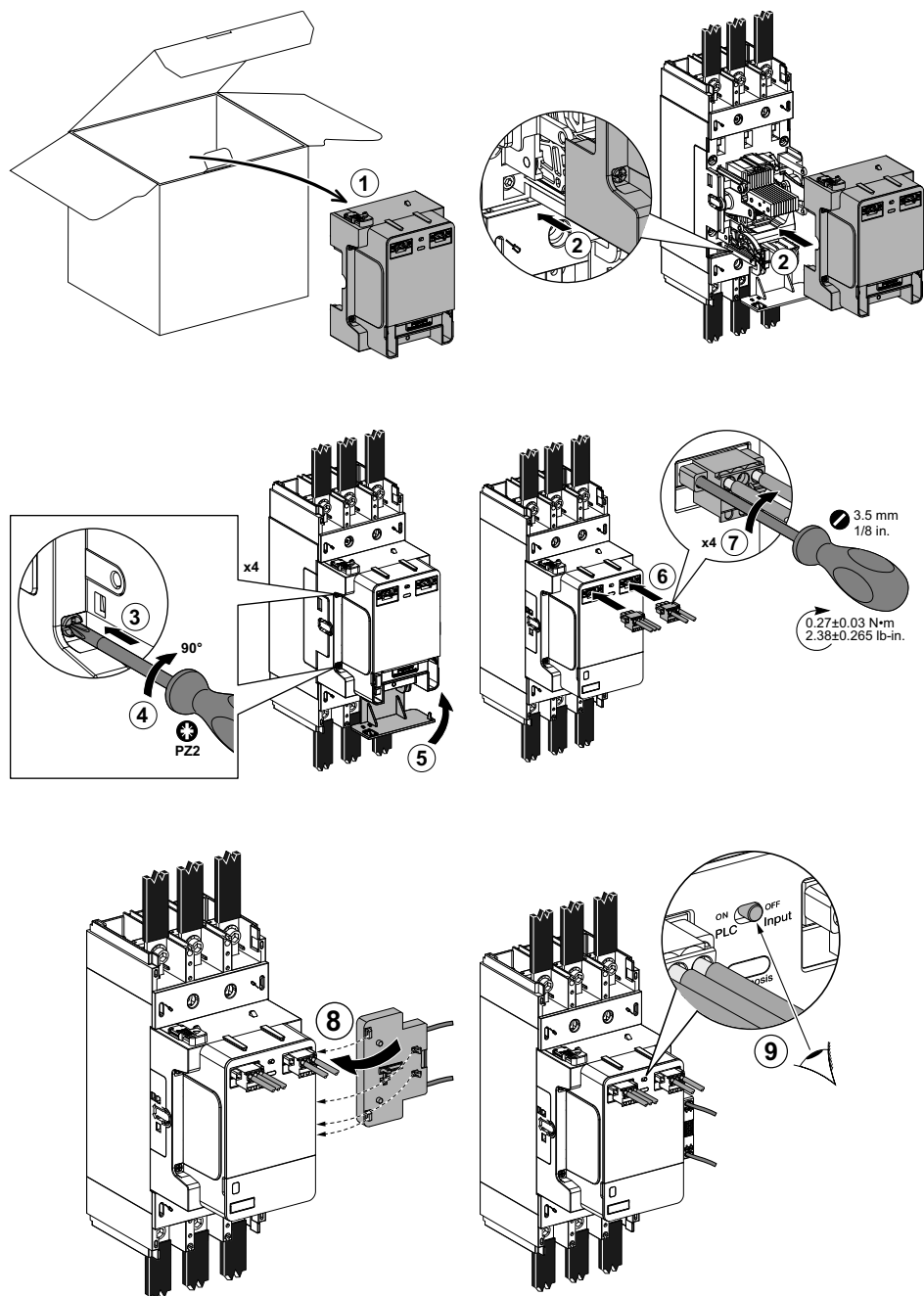

# Cybersecurity

## Introduction

At Schneider Electric, we have always considered cyber security as a key requirement and are committed to providing more reliable, stable, and secure products to minimize potential cyber risks and better protect customer life, property, and the environment.

Cybersecurity aims to protect your systems, communications networks, devices, etc., from possible attacks such as destruction, data tampering, or disclosure of confidential information. In addition to the recommendations in this chapter for TeSys Giga, it is strongly recommended that you follow the Schneider Electric Defense in Depth approach to cybersecurity. In our system technical note "How to reduce vulnerability to cyber attacks?", this method is described. In addition, you can find more useful resources and up-to-date information at Schneider Electric's Cybersecurity Support Portal.

## Schneider Electric Approach on Cybersecurity

Schneider Electric adheres to industries best practice in the development and implementation of control systems. This includes a defense-in-depth approach to secure an industrial control system. This approach places the controllers behind one or more firewalls to restrict access to authorized personnel and protocols only.

### WARNING

#### **UNAUTHENTICATED ACCESS AND SUBSEQUENT UNAUTHORIZED OPERATION**

- Evaluate whether your equipment or complete environment are connected to your critical infrastructure. If so, take appropriate steps in terms of prevention, based on defense-in-depth, before connecting the automation system to any network.
- Limit the number of devices connected to a network inside the company.
- Isolate industrial network from other networks in the company.
- Protect any network against unintended access by using firewalls, VPN, or other, proven security measures.
- Monitor activities within your systems.
- Prevent subject devices from direct access or direct link by unauthorized parties or unauthenticated actions.
- Prepare a recovery plan including backup of your system and process information.

**Failure to follow these instructions can result in death, serious injury, or equipment damage.**

## Equipment Security

Use digital signature technology based on public key infrastructure PKI, to ensure the device firmware believable and integrity, and prevent malicious code injection.

Disable all debug ports when equipment out of factory, to prevent the attacker to read device firmware and configuration of the data in the device.

## Firmware Upgrade

Firmware designed for the device is signed by the Schneider Electric Public Key Infrastructure (PKI) to ensure the integrity and authenticity of the firmware running on the device.

- Register on the Schneider Electric's Cybersecurity Support Portal.
- Contact Schneider Electric technical support or local agent to help you update the device firmware.

## Security Disposal

It is required to destroy the device through a safe channel to ensure that the device is not re-deployed to your operational systems or illegally exploited.

## Vulnerability Reporting and Management

You can access the Schneider Electric Cybersecurity Support Portal to check the vulnerability management policy or report potential cybersecurity vulnerability.

# Troubleshooting

## Installation

Problem description	Probable causes	Solution
Difficult to install the contactor on a plate	Incorrect drilling dimension or not use of hang on function pin or screws	Follow the contactor installation instructions, TeSys Giga Contactor Mounting on Plate, page 75.
Difficult to install the overload relay on a plate	Incorrect drilling dimension	Follow the overload relay installation instructions, TeSys Giga Electronic Overload Relay Mounting on Plate, page 79.
Difficult to install auxiliary contact modules on the contactor	Cannot position well the driving pin or the locating features	Follow the auxiliary contact module installation instructions, Installation of the Auxiliary Contact Modules, page 139.

## Operation

Problem description	Probable causes	Solution
Contactor does not close and the Diagnosis LED on the control module flashes 2 times regularly	The control voltage is lower than 80 % of $U_{cmin}$	Check the control voltage.
Advanced contactor does not close	<b>PLC Input</b> switch status not aligned with control wiring diagram	Check the <b>PLC Input</b> switch status or the control wiring diagram.
Contactor does not close	Error in the wiring of the control circuit	Check the control wiring diagram, Control Mode, page 25.
	The magnetic circuit cannot close due to dust or mechanical issue	Remove the control module, Control Module Replacement, page 205, and clean the accessible parts with a dry cloth.  If the problem persists, contact your Schneider Electric field service representative.
	Poles cannot close due to mechanical issue	Remove the switching modules, Switching Module Replacement, page 196, and clean the accessible parts with a dry cloth. Test manually the switching modules to detect if there is a blocking point.  If the problem persists, replace the switching modules, Switching Module Replacement, page 196.
Overload relay unexpected trip	Error in the protection settings	Check the protection settings, Current-Based Protection Functions, page 33.
	Too high level of vibration on overload relay	Check the vibration environment.
	Huge magnetic field in the environment of the overload relay	Add an external magnetic shield around the overload relay.
Overload relay manual reset does not work	<b>Reset</b> button is not fully pushed	Fully push <b>Reset</b> button again.

## Contactor Switching Modules

Problem description	Probable causes	Solution
Cannot remove switching modules	Still some screws tightened	Check all the screws are untightened.
Difficult to change the switching modules	Sequence to remove cable, auxiliary contact modules, mid frame screw	Follow the switching module replacement instructions, Switching Module Replacement, page 196.

## Contactor Control Module

Problem description	Probable causes	Solution
The Diagnosis LED on the control module blinks continuously	Control module internal malfunction detected	Replace the control module, Control Module Replacement, page 205
The Diagnosis LED on the control module flashes 4 times regularly	Remote wear diagnosis module and contact wear diagnosis function are not synchronized	Change the position of <b>Reset</b> button on the remote wear diagnosis module.

## Overload Relay

Problem description	Probable causes	Solution
Overload relay motor ON LED blinking	Overload relay internal malfunction detected	Replace the overload relay.
The motor is supplied but the overload relay motor ON LED is OFF.	LED is out of order	Replace the overload relay.

Schneider Electric  
35 rue Joseph Monier  
92500 Rueil Malmaison  
France

[www.se.com](http://www.se.com)

As standards, specifications, and design change from time to time, please ask for confirmation of the information given in this publication.

© 2025 Schneider Electric. All rights reserved.

DOCA0189EN-06