

The Schneider Electric logo, consisting of the brand name in a green sans-serif font with a stylized 'E' icon to the right.

Line Series

Canalis™ for EV

Outdoor Charging Infrastructure

Catalogue 2026
Powered by Canalis KS 100 to 400 A

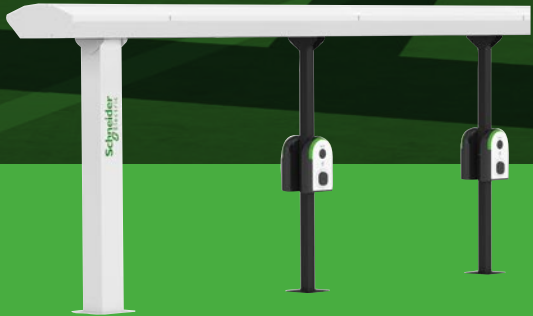

se.com

Life Is On | **Schneider**
Electric



Contents

Presentation

A

Design Guide

B

Description

C

Catalog Numbers and Dimensions

D

Index

E

Electrical mobility challenges for today and tomorrow

A

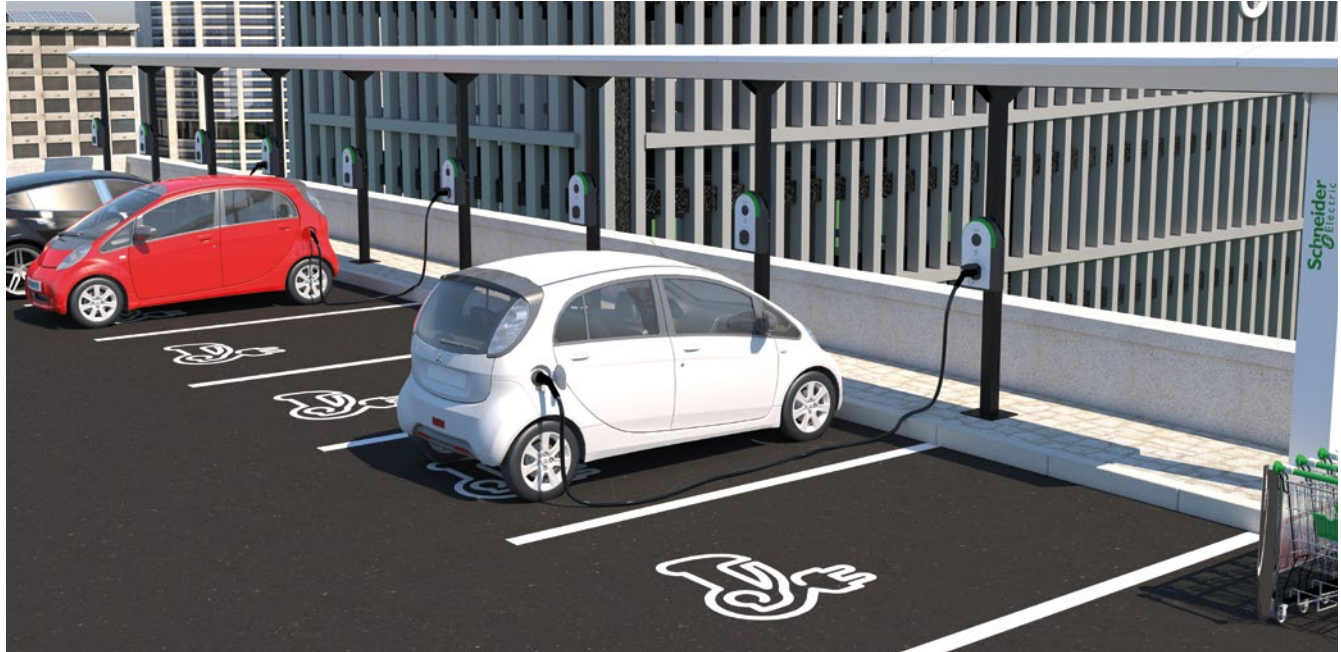

B

C

D

What are the challenges to facilitate the transition to electric mobility?

To promote large-scale adoption of electric vehicles, it is crucial to develop a sufficient network of charging stations

Regulations push investors to prepare for the near future by anticipating the availability of energy, pre-equipment, or the use of scalable solutions.

However, the future remains uncertain, and regulations change quickly. Agility and flexibility are essential to address key challenges.

E

What are the conditions to reach the objectives?

- Reduce the price per charge-point
- Be flexible in the face of the uncertainty
- Add new charge points over time
- Reduce the installation time and cost
- Manage the coordination of numerous activities, respecting a tight schedule.

Canalis, flexible and future ready solution

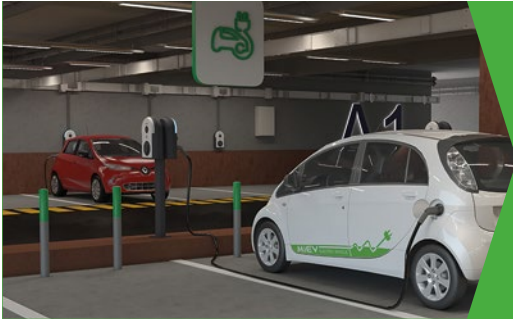

Canalis busbar trunking system

Decentralized EV chargers' electrical distribution with Canalis™ busbar trunking system allows you to save time and cost on installation, and to be ready for future extensions.



Why Canalis is recommended for EV charging infrastructure?

- Maintenance-free with low footprint
- Time and cost savings thanks to fast assembly, fewer cables, no distribution panel
- Flexible and smartly expandable as a modular system and pre-assembled plug-and-play boxes
- Halogen-free and low fire-load
- Optimal for pre-fitting and future expansion

A

B

C

D

E

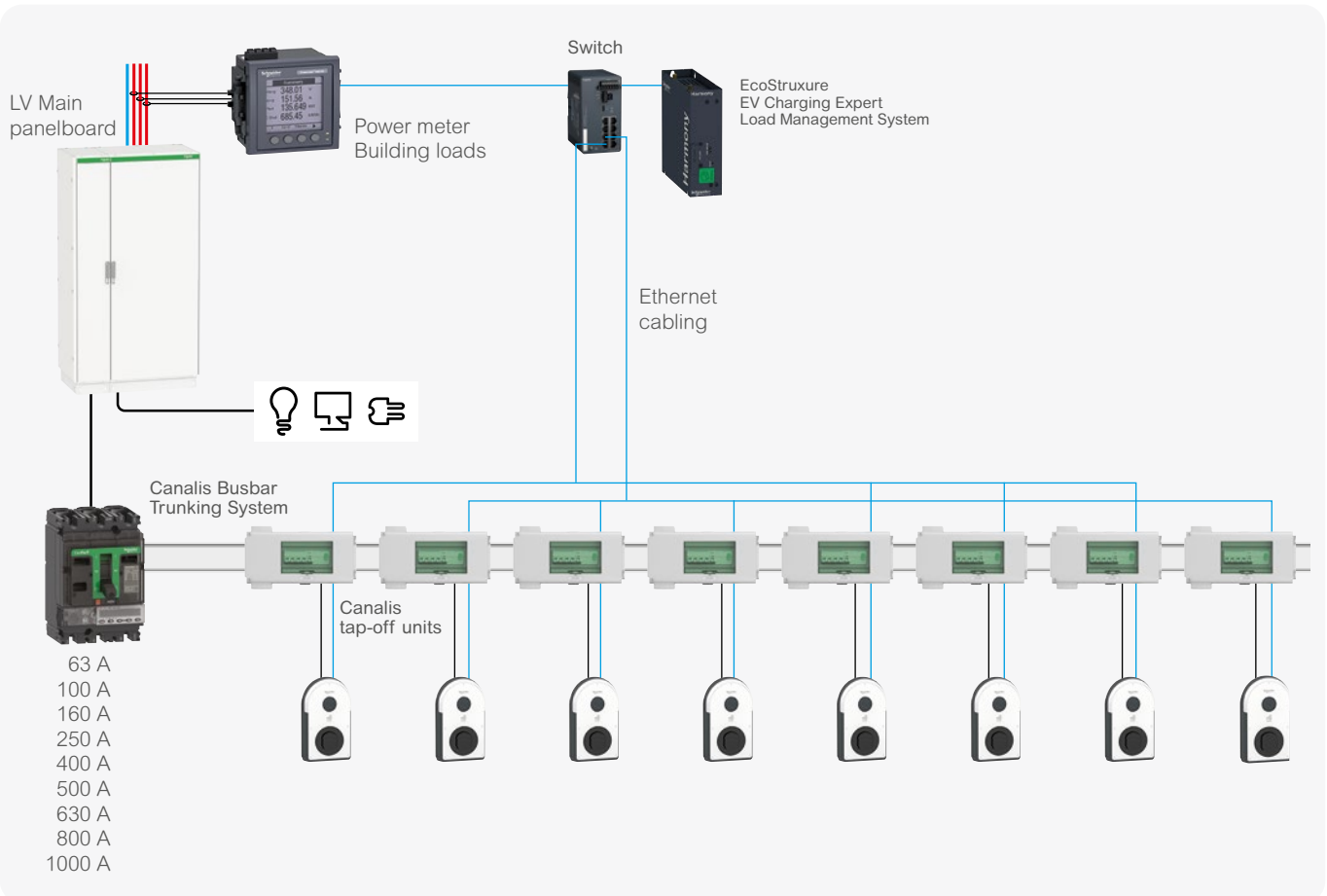

A Canalis innovation for all EV applications

A

The new energy landscape is bringing tremendous opportunities for **electrification** to contribute to **sustainability** goals. Canalis meets the demand for all types of infrastructure

B



Indoor car park



Multi-storey car park



Under PV carport



Outdoor Charging Infrastructure

C

D

Outdoor charging infrastructure

E

The large-scale deployment of charging infrastructure in outdoor car parks is essential to support the transition to electric vehicles.

Busbar trunking system is a suitable solution that is fast to install and expand. It can help you prepare you for future uncertainty.

Canalis for EV is a plug-and-play system, powered by Canalis KS and based on a modular design.

It is composed of prefabricated parts which are available through the distribution network.

Canalis for EV offers several benefits compared to the standard solution through cables.

- **Flexible:** compatible with all chargers, regardless of brand, power, etc.
- **Scalable:** expandable whenever required
- **Simple:** easy to select, easy to order, easy to transport, easy to install, maintain, and extend.



A new concept for outdoor charging stations



A

B

C

D

E

Change for a decentralized distribution...

An environmentally friendly lifecycle

Manufacturing, packing and distribution processes have been designed to limit the environmental impact of our products. In service, KS busbar trunking dissipates less than 0.1% of the total power circulating in the product. At end of life, over 90% of the materials used can be recycled by crushing or dismantling.

...and limit the civil works and the environmental impacts

Light and easy to handle

The canopy and pillar components are designed to be lightweight, allowing for efficient installation by a team of just two people.

Incomparable scalability

The design of this structure allows for scalability at any point during its lifespan.

Easy relocation

The design of this structure allows for relocation at any point during its lifespan.

Options for main Input cables

Incoming cables can be routed from the first pillar or through the canopy if the structure is positioned close to the wall or it can be also planned as central feed unit system.

A modular solution to bring a maximum of possibilities



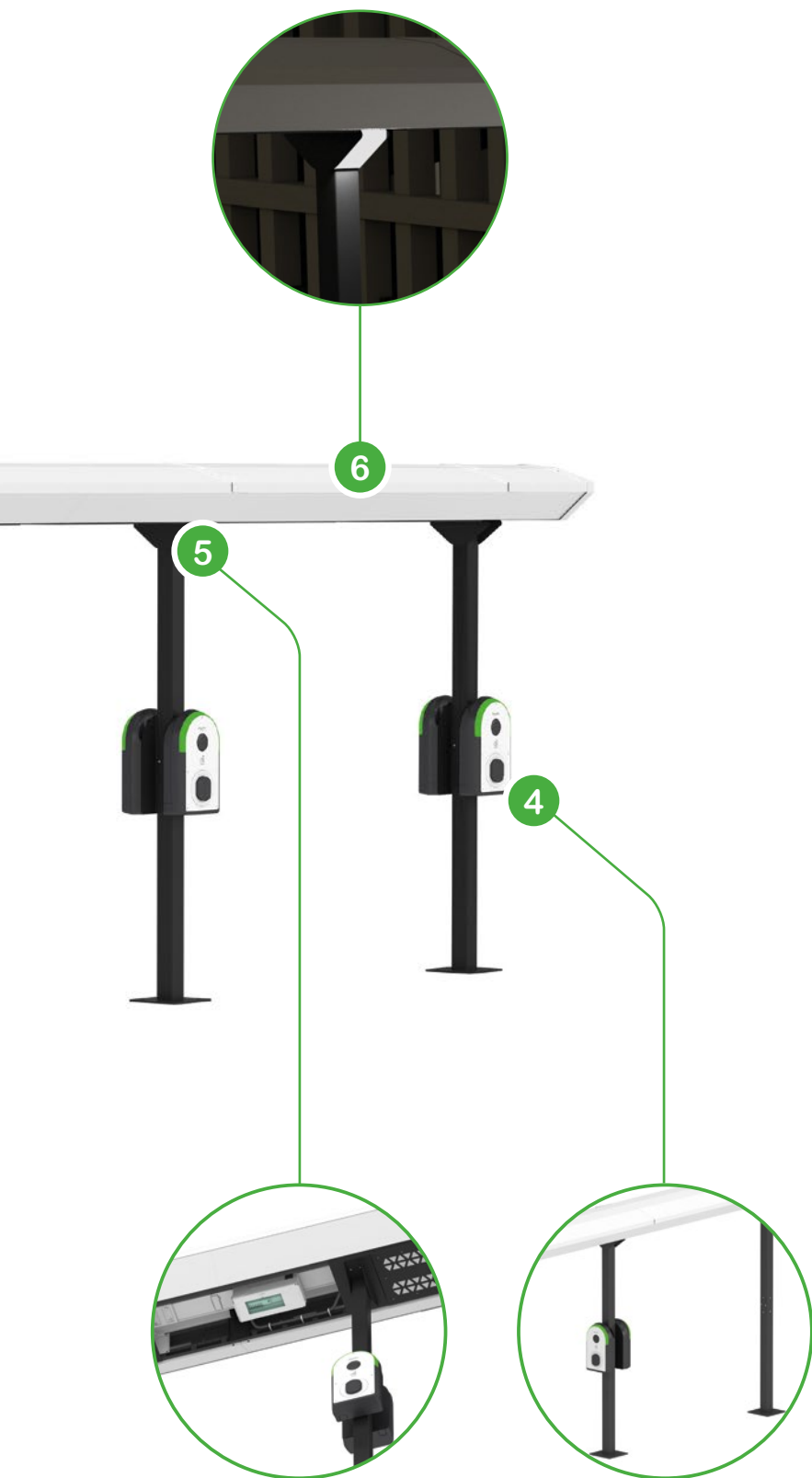

- 1 Chargers are powered by Canalis KS busbar trunking and its tap-off units
- 2 Canalis is fed by cables coming through the feed pillar
- 3 Canalis can be fed from the top when the canopy is next to a building
- 4 The structure is suitable for a large number of chargers, of all types, installed in front or side
- 5 Adapted for all situations, regardless of the parking space size
- 6 The structure can be equipped with lights to help the car connection
- 7 The canopy surface can be used to identify the parking places with numbers, company name, etc.
- 8 The feed pillar can be customized to be equipped with a payment terminal.

A

B

C

D

E

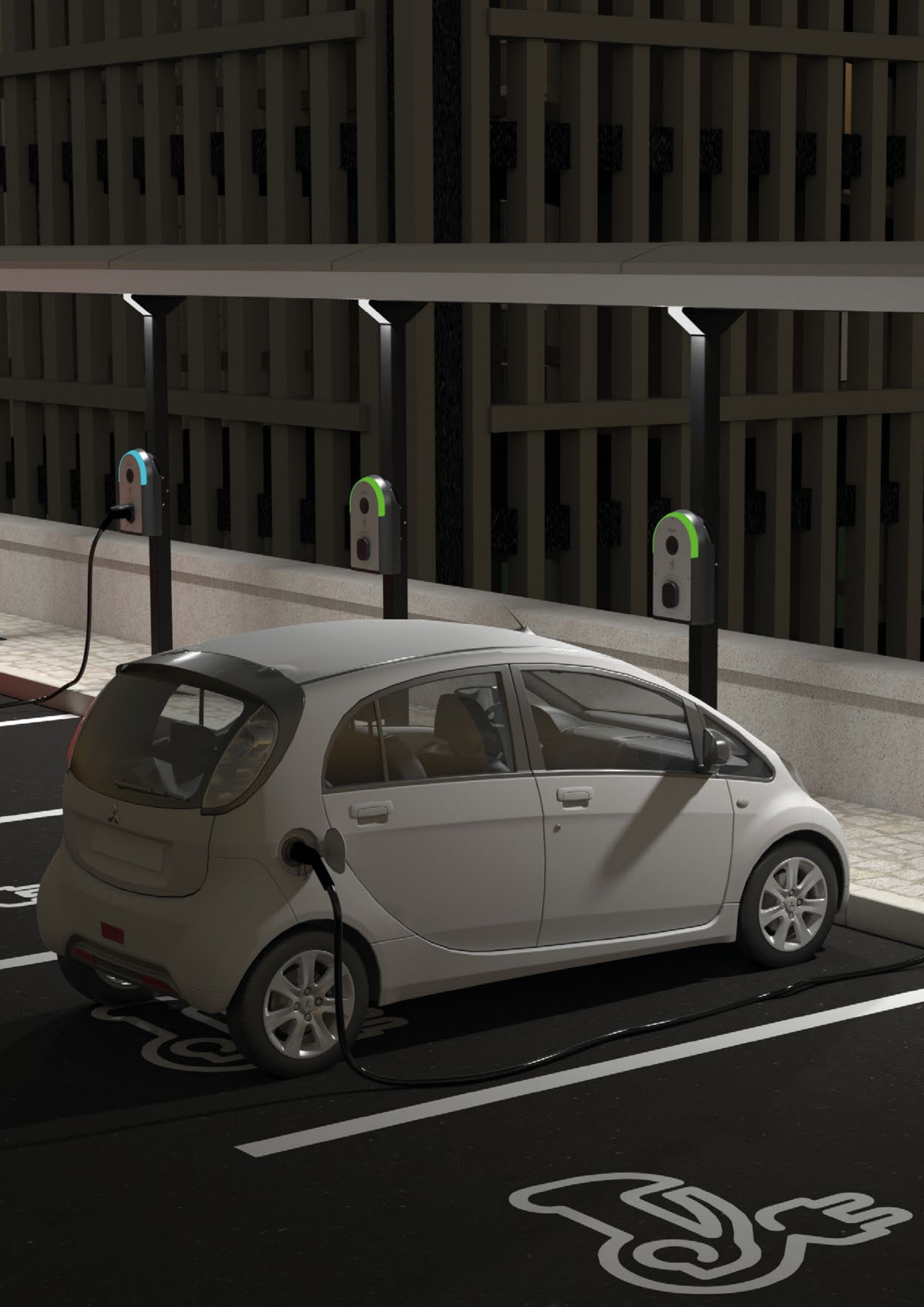

Design Guide

- Identify your needs 12
- Determine your power distribution 13
- Identify the way to fix the pillars on the ground..... 14
- Select the suitable chargers position..... 15
- Define the lenght of the canopy..... 16
- Get your bill of material..... 18
- Use product selectors for a faster calculation 19
- Installation rules and maintenance 20
- Compare architectures 24



A





B

C

D



E

Where to charge?	Parking time	Charging type	Recommended charger type	Main characteristics
 At home (multifamily building)	Up to 8 hours	Low , recharging of the consumption of a daily usage (average 30 kms)	3.6 to 22 kW AC	The total required power is reduced due to the diversity factor and the Load Management System.
 At work	Up to 8 hours	Low , recharging of the consumption from home to work (average 30 kms)	3.6 to 22 kW AC	A lot of parking places can be equipped with AC chargers.
 At shop	2 to 4 hours	Medium	3.6 to 22 kW AC	
 In transit	Less than 10 min	High	250 to 350 kW DC	Fast DC chargers are required

A busbar trunking system is recommended

Determine your power distribution

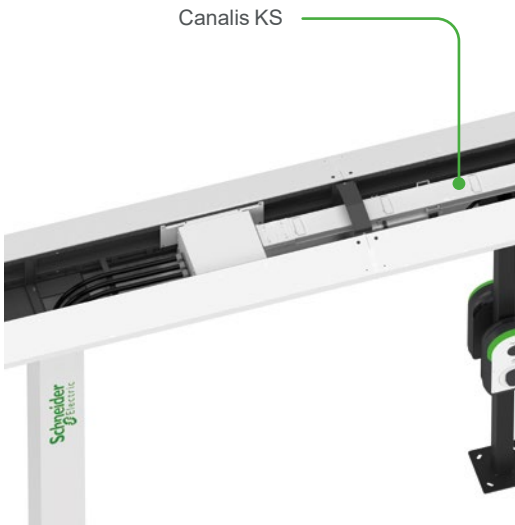

Canalis KS

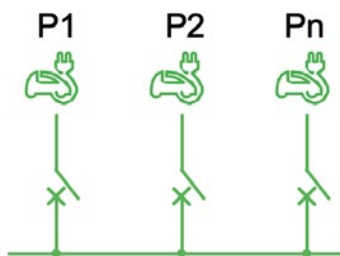

Calculation

In general, the required power is:

$$P = \sum_{i=1}^{nb \text{ of chargers}} P_i \cdot k_i$$

Where P_i is the power of the generic charging point and k_i is a correction coefficient which includes:

- The diversity factor
- The environmental factor
- The reserve for future chargers

Eg: Which Canalis KS to use to connect 16 chargers 11 kW 3P AC?

- Power factor = 1
- Diversity factor = 0.4
- Reserve = 25%
- Ambient temperature max = 45°C Derating factor = 0.81

$$P_i = 16 \times 11 = 176 \text{ kW}$$

$$k_i = 0.4 \times 1.25 = 0.5$$

$$P = 176 \times 0.5 = 88 \text{ kW}$$

$$U = 400 \text{ Volt}$$

$$I_e = P / U / \sqrt{3} = 88000 / 400 / 1.73 = 127 \text{ A}$$

$$I_n = I_e / 0.81 = 156 \text{ A}$$

> Canalis KSA160 is the solution

Environmental factor

High solar radiation and ambient temperature must be considered when sizing the Canalis KS installed under the canopy.

Max ambient temp at max solar radiation (1000W/m ²)	Coefficient to apply
35°C	0.87
40°C	0.84
45°C	0.81
50°C	0.78
55°C	0.74

Why a Load Management System (LMS)?

The charging requirements of electric vehicles can vary considerably depending on the application: powers, quantities of charging stations, charging times, speeds, etc.

Without a load management system, the electrical installation is sized for the full power, including future extensions. Since there is no load management system, all charging points can be used simultaneously, the diversity factor is therefore 1

With a static load management system, the overall dimensioning of the power and the busway is reduced. The electrical installation is sized for the full power, including future extensions, but with a diversity factor of 0.4, and therefore a power limitation of the electric vehicle charging stations to remain below the line capacity. However, this solution does not allow to take advantage of all the power available on site.

With a dynamic load management system that dynamically allocates 100% of the available power of the electrical installation, thus allowing to increase the number of vehicles charged simultaneously when the other loads of the site are not used.

Define your Canalis KS

Based on a diversity factor at 0.4 using a Load Management System, without reserve. Calculated with the maximum solar radiation on earth (1000 W/m²)

Number of chargers 7.4 kW 1P AC		Canalis type			
		KSA100	KSA160	KSA250	KSA400
Maxi ambient temperature	35°C	18	30	48	81
	40°C	18	30	48	78
	45°C	18	30	45	75
	50°C	18	27	45	72
	55°C	15	27	42	69

Number of chargers 11 kW 3P AC		Canalis type			
		KSA100	KSA160	KSA250	KSA400
Maxi ambient temperature	35°C	13	21	33	54
	40°C	13	21	32	52
	45°C	12	20	31	50
	50°C	12	19	30	48
	55°C	11	18	28	46

Number of chargers 22 kW 3P AC		Canalis type			
		KSA100	KSA160	KSA250	KSA400
Maxi ambient temperature	35°C	6	10	16	27
	40°C	6	10	16	26
	45°C	6	10	15	25
	50°C	6	9	15	24
	55°C	5	9	14	23

Identify the way to fix the pillars on the ground

A



B

Without sidewalk



With concrete sidewalk



With grass sidewalk

C

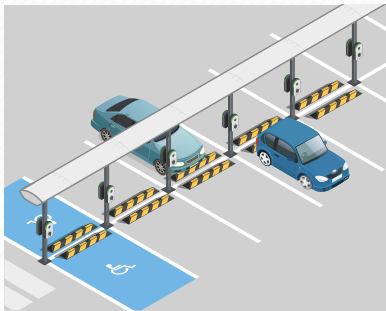

Direct fixing in a poured concrete support



Direct fixing in the concrete of the sidewalk

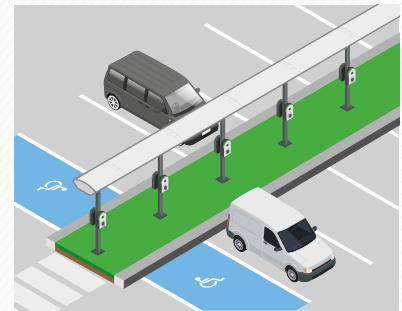

Direct fixing in prefabricated blocks

D

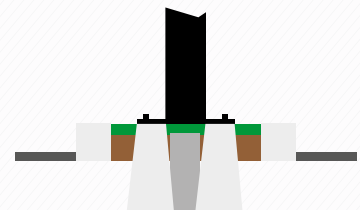
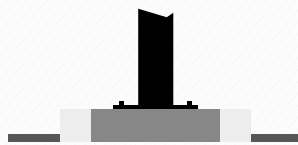
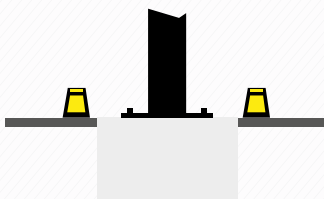

E

Examples of the use of support screws or prefabricated blocks

Screws



Prefabricated blocks



Pillar distance



For installation above the pillar distance of 3.2 m up to 3.5 m order CR number KEV0400BP1000B quantity 1 per 2 car parking places.

Select the suitable chargers position

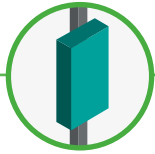

Chargers in front

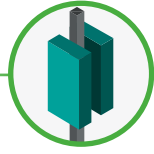

Laterally face-to-face

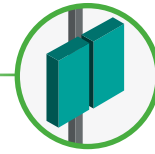

Side-by-side or dual charger sockets

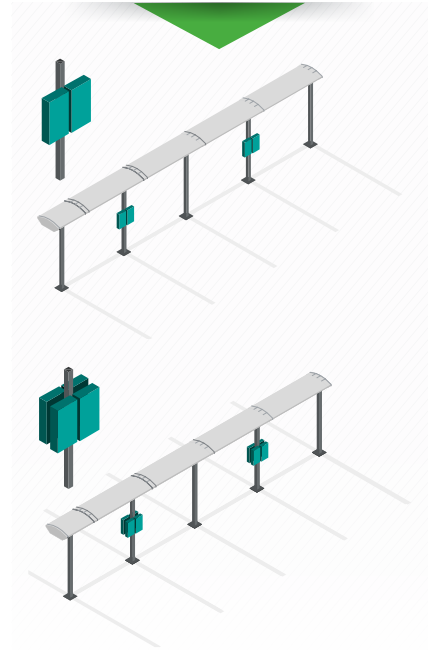
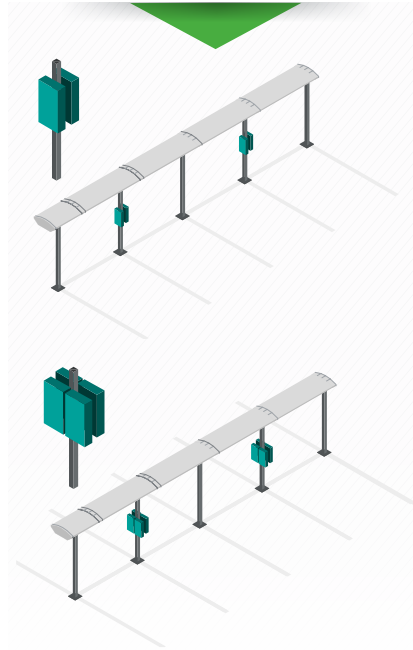
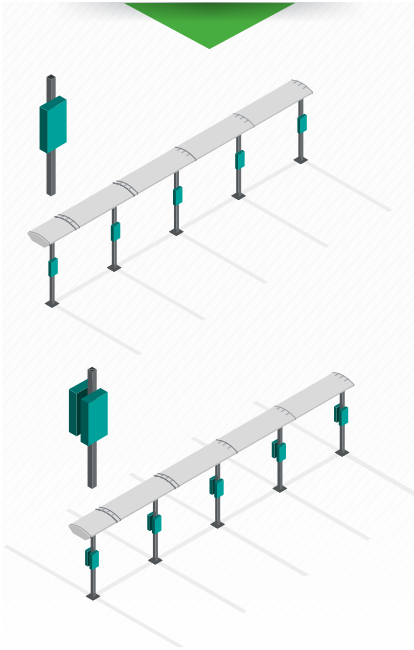

Pillars between cars

Pillars in front of cars

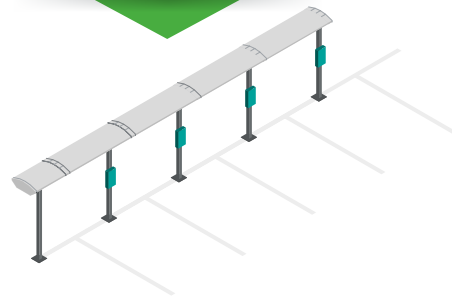
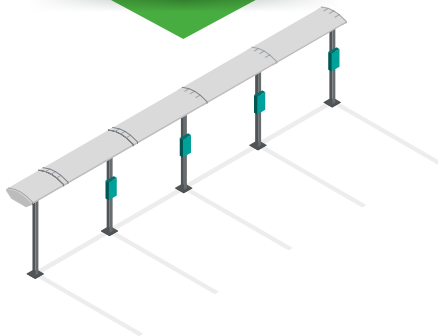

Perpendicular

Angled

Parallel

One side

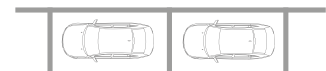
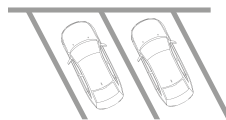
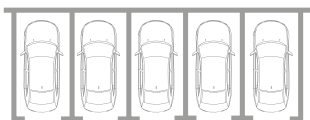

Face to face

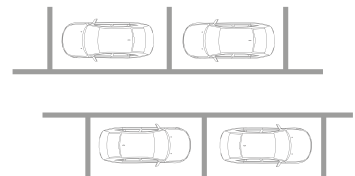
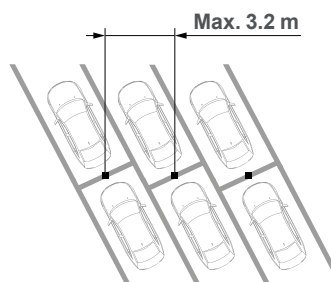
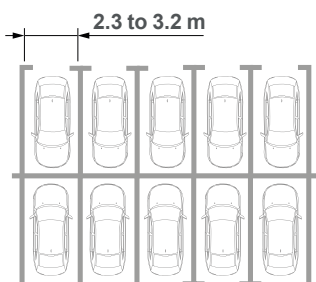

Define the length of the canopy

A

B

C

D

E

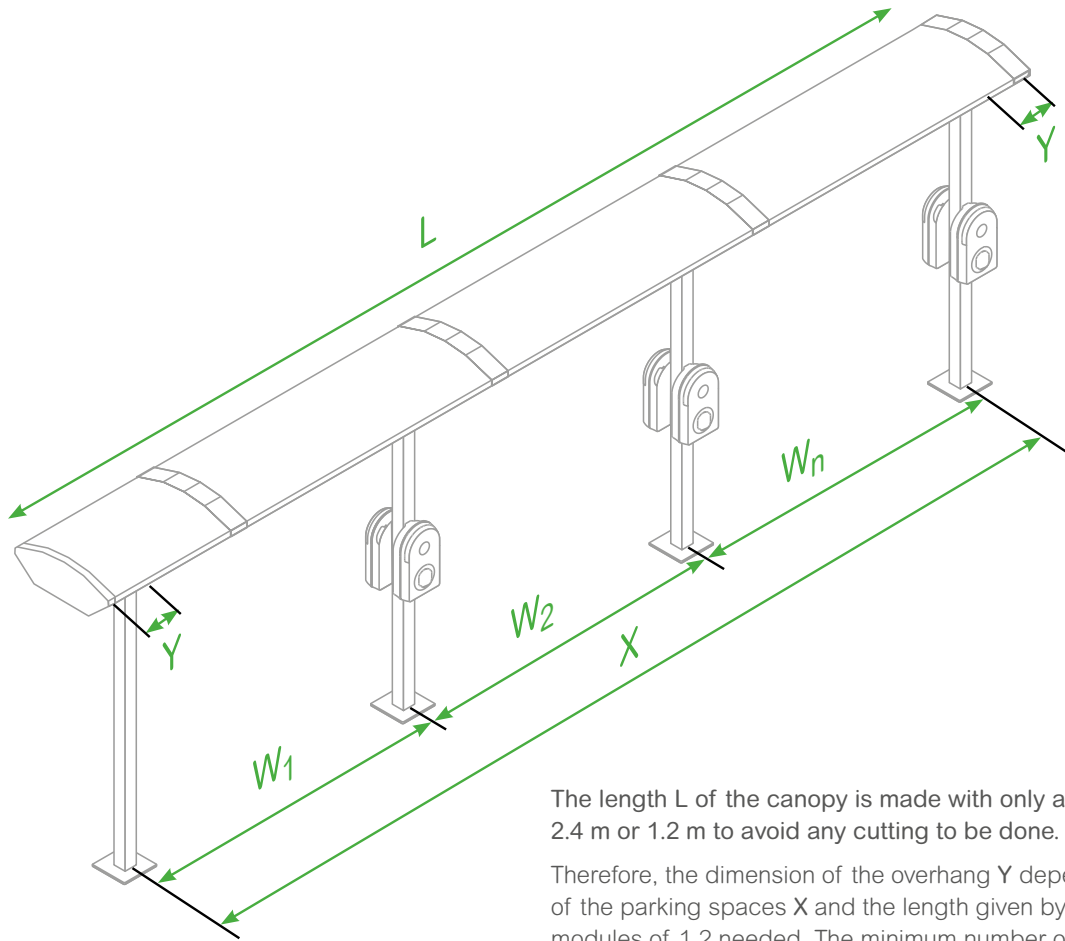

The length L of the canopy is made with only an assembly of parts of 2.4 m or 1.2 m to avoid any cutting to be done.

Therefore, the dimension of the overhang Y depends on the total length of the parking spaces X and the length given by the minimum number of modules of 1.2 needed. The minimum number of modules is calculated to respect two conditions: A minimum overhang of 0.2 m and a maximum of 0.6 m.

If those conditions cannot be fulfilled, the distance of the two last pillars will have to be adjusted.

$$X = W1 + W2 + \dots + Wn$$

$$L = X + 2Y \text{ with } Y \text{ mini} = 0.2 \text{ m and } Y \text{ maxi} = 0.6 \text{ m}$$

Asymmetric extremities is possible - Need to [connect Schneider front office](#)

- Max limit on either side should not cross 600 mm
- Possible for one side with 200 mm and other side with 600 mm or vice versa

Example: 200 mm on Incoming cable pillar side and 600 mm on the EV charger pillar side.



Eg: 10 parking spaces of 2.6 m

$$X = 26 \text{ m}$$

> Minimum number of module of 1.2 m = $\lceil X / 1.2 \rceil + 1 = \lceil 21.6 \rceil + 1 = 22$

> L mini = $22 \times 1.2 = 26.4 \text{ m}$

> $Y = (L-X)/2 \quad Y = (26.4 - 26)/2 = 0.2$

Y is greater than or equal to 0.2 and less than or equal to 0.6, the number of modules of 1.2 m is validated at 22.

Define the length of the canopy

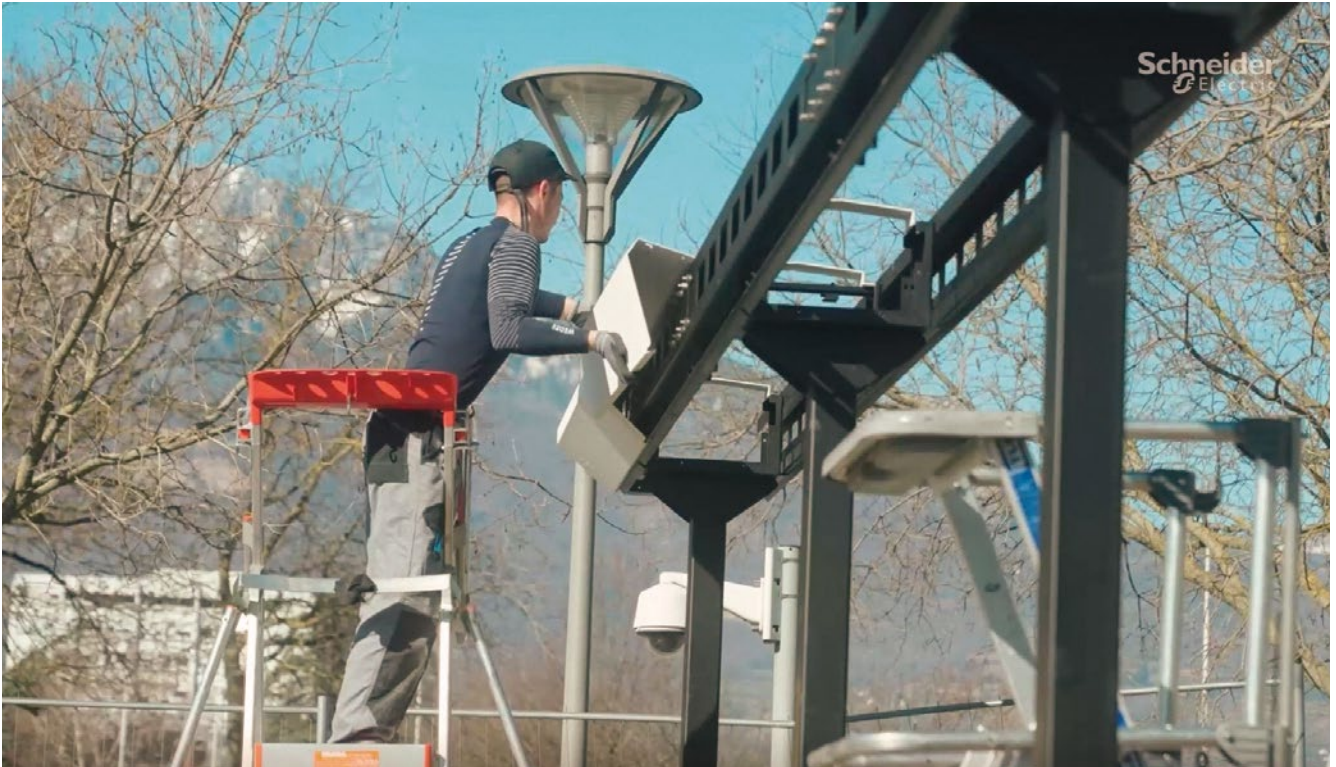

A

B

C

D

E

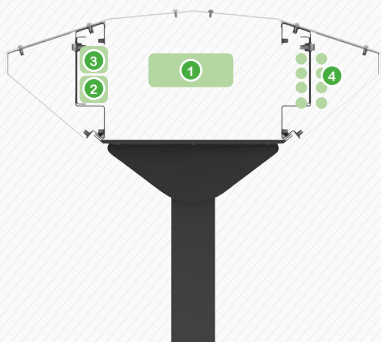

The system provides several areas to transport busbar trunking system or cables, see in the picture examples of available areas

- Size of location 2 and 3 is W 65 mm x H 150 mm
- Area 150 mm² = 4 x 240 sqmm

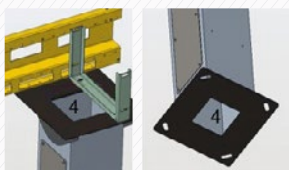

- 1 Canalis KS 100 to 400 A
- 2 Communication cables storage
- 3 Canalis KB 25 to 40 A for lighting
- 4 Other power cables

Calculate the canopy length

	Width of parking spaces				
	2.5 m	2.6 m	2.7 m	2.8 m	
Number of car places one side N⁽¹⁾	6	15.6	16.8	16.8	18
	7	18	19.2	20.4	20.4
	8	21.6	21.6	22.8	22.8
	9	24	24	25.2	26.4
	10	26.4	27.6	27.6	28.8
	11	28.8	30	31.2	31.2
	12	31.2	32.4	33.6	34.8
	13	33.6	34.8	36	37.2
	14	36	37.2	38.4	39.6
	15	38.4	39.6	42	43.2
	16	40.8	43.2	44.4	45.6
	17	43.2	45.6	46.8	48
	18	45.6	48	49.2	51.6
	19	48	50.4	52.8	54
	20	51.6	52.8	55.2	57.6

(1) For face-to-face configuration N is the number of parking spaces on one side only.

Example: To equip 30 parking spaces of 2.6 m facing each other, 15 on each side. N = 15 means L = 39.6

Get your bill of material

A

B

C

D

E

		Length of the canopy (m)																		
Catalog number	Description	8.4	9.6	10.8	12	13.2	14.4	15.6	16.8	18	19.2	20.4	21.6	22.8	24	25.2	26.4	27.6	28.8	
KEV0400CP2400B	CANALIS EV 1 X CHARGER PILLAR 2400 BLACK	N	N	N	N	N	N	N	N	N	N	N	N	N	N	N	N	N	N	N
KEV0400TS1B	CANALIS EV 1 X CHARGER PILLAR SUPPORT BL	N	N	N	N	N	N	N	N	N	N	N	N	N	N	N	N	N	N	N
KEV0400BV1B	CANALIS EV 1 SET OF VENTILATIONS BLACK	N	N	N	N	N	N	N	N	N	N	N	N	N	N	N	N	N	N	N
KEV0400SR2400	CANALIS EV 2 X SIDE RAILS 2400	3	4	4	5	5	6	6	7	7	8	8	9	9	10	10	11	11	12	
KEV0400SR1200	CANALIS EV 2 X SIDE RAILS 1200	1	0	1	0	1	0	1	0	1	0	1	0	1	0	1	0	1	0	
KEV0400SC2400W	CANALIS EV 2 X SIDE CLOSURES 2400 WHITE	3	4	4	5	5	6	6	7	7	8	8	9	9	10	10	11	11	12	
KEV0400SC1200W	CANALIS EV 2 X SIDE CLOSURES 1200 WHITE	1	0	1	0	1	0	1	0	1	0	1	0	1	0	1	0	1	0	
KEV0400TR2400W	CANALIS EV 1 X TOP ROOF 2400 WHITE	3	3	4	4	5	5	6	6	7	7	8	8	9	9	10	10	11	11	
KEV0400TR1200W	CANALIS EV 1 X TOP ROOF 1200 WHITE	1	2	1	2	1	2	1	2	1	2	1	2	1	2	1	2	1	2	
KEV0400CO1W	CANALIS EV 1 X TOP ROOF CONNECTION WHITE	3	4	4	5	5	6	6	7	7	8	8	9	9	10	10	11	11	12	
KEV0400EP2400W	CANALIS EV 1 X FEED PILLAR 2400 WHITE	1	1	1	1	1	1	1	1	1	1	1	1	1	1	1	1	1	1	
KEV0400ES1B	CANALIS EV 1 X FEED PILLAR SUPPORT BLACK	1	1	1	1	1	1	1	1	1	1	1	1	1	1	1	1	1	1	
KEV0400EC1W	CANALIS EV 2 X END CLOSURES WHITE	1	1	1	1	1	1	1	1	1	1	1	1	1	1	1	1	1	1	
KEV0400BP1000B	CANALIS EV 1 X BOTTOM PLATE 1000 BLACK	1	1	1	1	1	1	1	1	1	1	1	1	1	1	1	1	1	1	
KEV0400FP1	CANALIS EV 1 SET OF FIXING PLATES FOR AB	1	1	1	1	1	1	1	1	1	1	1	1	1	1	1	1	1	1	
KEV0400SB1	CANALIS EV 2 X SIDE BRACKETS	1	1	1	1	1	1	1	1	1	1	1	1	1	1	1	1	1	1	
KEV0400FS1	CANALIS EV 1 X INTERMEDIARY FREE SUPPORT	Optionnal																		
KEV0400CS1	CANALIS EV 1 X PRO AC CHARGER SUPPORT	Optionnal																		
KEV0400SE1	CANALIS EV 1 X SUPPORT PLATE	Optionnal																		

N = Number of parking spaces on one side

Use product selectors for a faster calculation

Thanks to our product selectors, design and cost your projects in just a few clicks.

A complete bill of materials including all necessary components, from the structure to the chargers, will be created. With the easy-to-use Canbrass design tool, your 3D drawings and reports will be completed in minutes.

CanCAD and BIMbusway are the plugins that will help you quickly integrate the infrastructure in AutoCAD or Revit into BIM, they are available free of charge on our web platforms.

Product selector



CanBrass

> is a design and costing tool for Canalis busbar trunking runs.

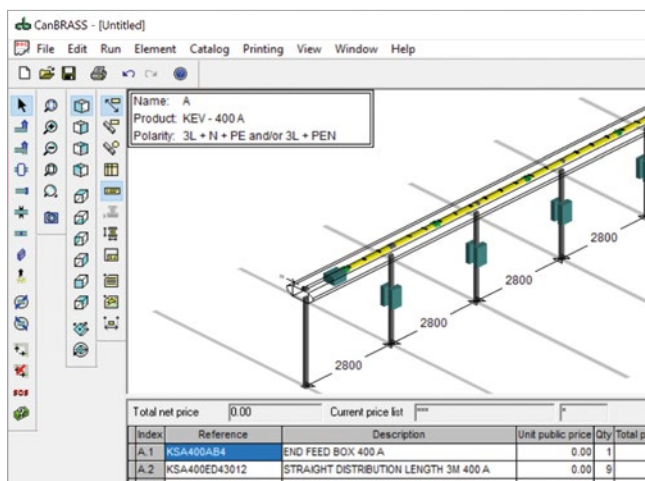

CanCad

> is a Plug-in for Autocad. It allows to easily design and get bill of materials.

BIMBusway

> is a Plug-in for Revit. It allows to easily design and get bill of materials in BIM format.

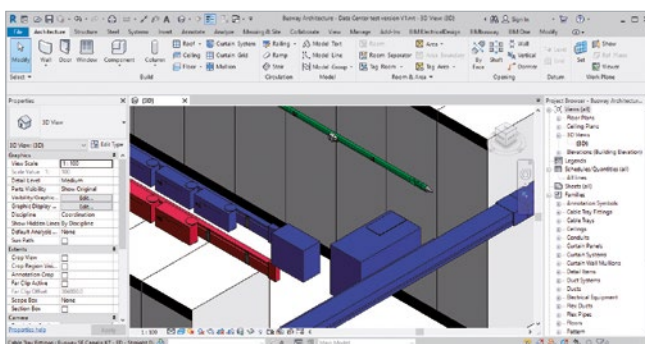

Installation rules and maintenance

A

Installation of the system in its environment

The modular system can match any car space number and width from 2.3 to 3.2 m. The possibility of installing the structure in a dedicated place has to be checked at an earlier stage. The right and left overhangs have to be considered for the total footprint.

The site data will be used by the installer to allow the dimensioning of the blocks necessary for the good stability of the assembly. The geotechnical elements, the seismic context, the snow, and the wind will be taken into consideration during the soil study.

B

Slope should be checked and adjusted accordingly while preparing the foundation.

If the structure is to be installed on a floor which has 1° slope, the alignment from the first to the last foundation point must remain straight and consistently parallel to the 1° slope.

For pillar installation and adjustment refer instruction sheet.

C

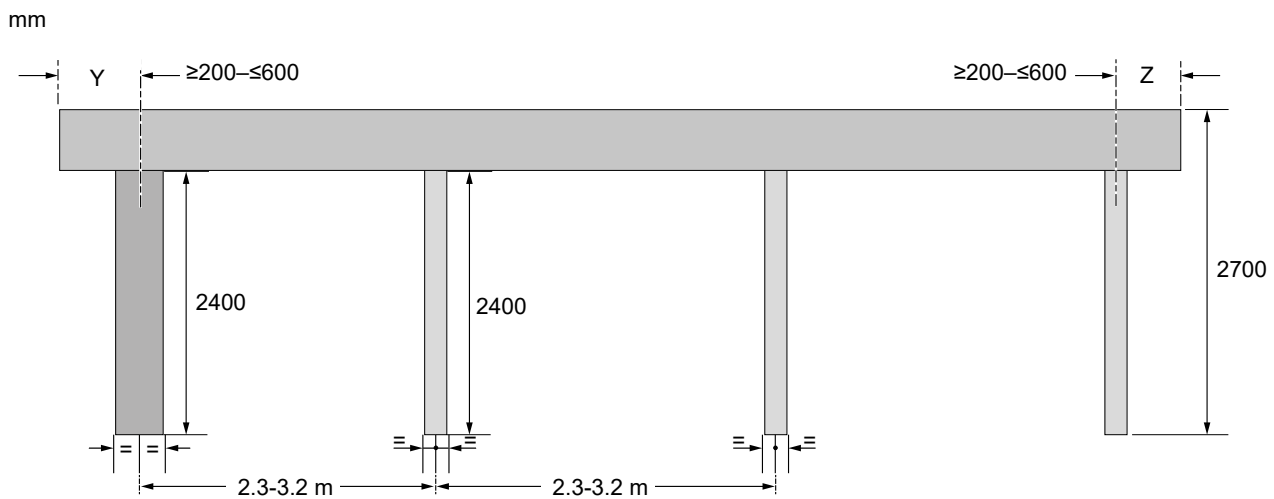

D

E

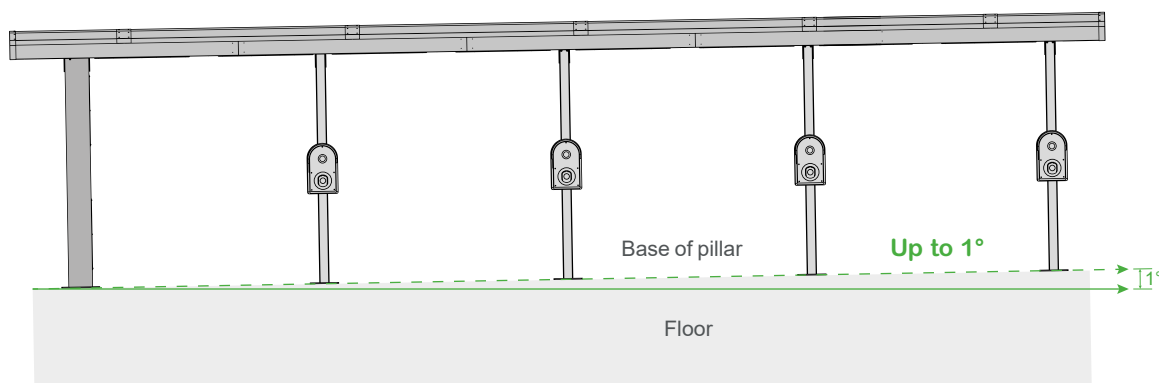

How to protect the system from damages?

In the case of installing the system on a concrete or grass sidewalk, keep a sufficient distance so that a vehicle parked up against the sidewalk does not hit the pillars, chargers and the upper part of the canopy.

In the case of installation on asphalt, provide the necessary wheel stops or protection barriers to avoid impacts from vehicles.

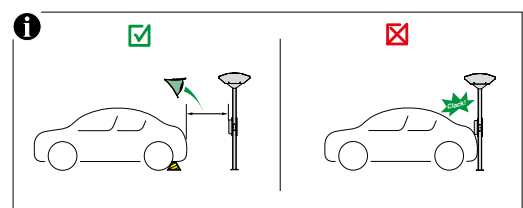

Installation rules and maintenance

What is weight on pillars base and dimensions to consider for foundations specifications?

Weight acting on Pillar Base

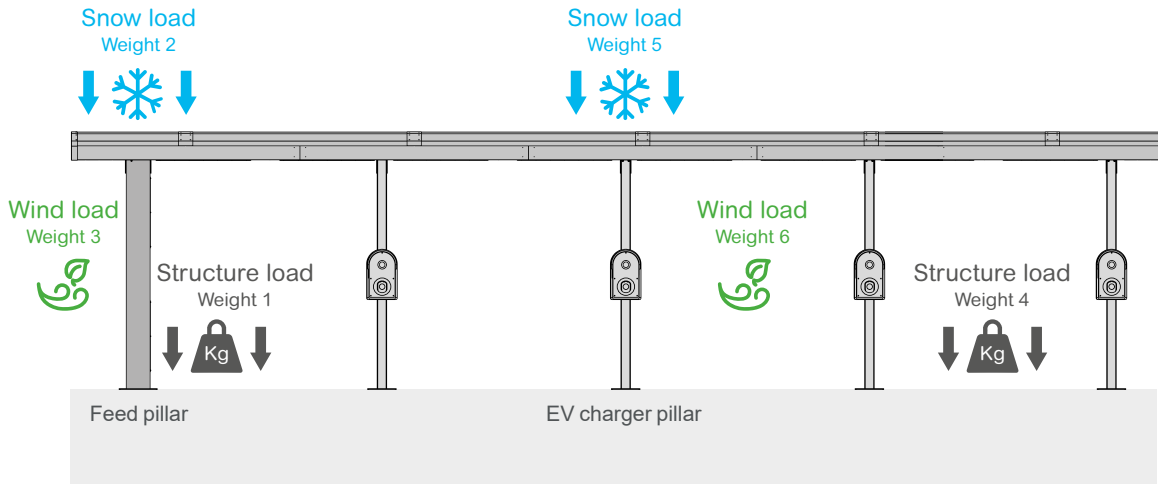

- **Weight 1:** self weight of feed pillar and Canopy on top of it = 200 kg.
- **Weight 2:** snow load should be considered based on region - Max snow load withstand capacity of structure is 90 kg/m².
- **Weight 3:** wind load should be considered based on region - Max wind load withstand capacity of structure is 210 km/hr - Below chart helps to find the weight acting on feed pillar due to wind load.

- **Weight 4:** self weight of pillar, Canopy and Charger = 250 kg.
- **Weight 5:** snow load should be considered based on region - Max snow load withstand capacity of structure is 90 kg/m².
- **Weight 6:** wind load should be considered based on region - Max wind load withstand capacity of structure is 210 km/hr - Below chart helps to find the weight acting on pillar due to wind load.

Weight 3 - On Feed unit pillar: converted to weight

Sl. no	Wind load		Remarks
	km/hr	kg	
1	210	195	Converted km/hr to kg
2	150	105	
3	100	45	

Weight 6 - On Charging pillar: converted to weight

Sl. no	Wind load		Remarks
	km/hr	kg	
1	210	145	Converted km/hr to kg
2	150	78	
3	100	34	

Example: Let's consider a region where the structure is installed with 2.5 m car parking space with snow load of 90 kg/m² with the wind load of 130 km/hr.

Total Weight on foundation (Feed unit pillar):
 weight 1 + weight 2 + weight 3 - 200+90+105 = 395 kgs.

Total Weight on foundation (Charging pillar):
 weight 4 + weight 5 + weight 6 - 250+90+78 = 418 kgs.

Installation rules and maintenance

A

How to ensure a proper grounding of the system?

The system's grounding must be achieved in compliance with the local regulations and laws for EV charging stations and must comply with the standards IEC 61851-1 and IEC 62196.

The recommendation is to ground the bottom bolt of the first pillar of the row to an external protective earth by the applicable standards and local regulations.

The ground electrode wire size is to be determined as per IEC 60364-5-54.

The ground continuity of the canopy parts is achieved by using the proper supplied bolts and washers, and to apply the torque values given in the instruction sheet.

Ground resistance testing must be performed during the commissioning phase and at every periodic maintenance as per IEC 60364 building electrical installations.

Ground resistance measurements should be taken between all fixing hardware.

The measured resistance values on the canopy assembly should be less than 0.1 ohm (Ω).

Additional ground rods must be installed if the ground resistance exceeds the threshold value of (0.1 ohm (Ω)) as defined by applicable standards and local laws.

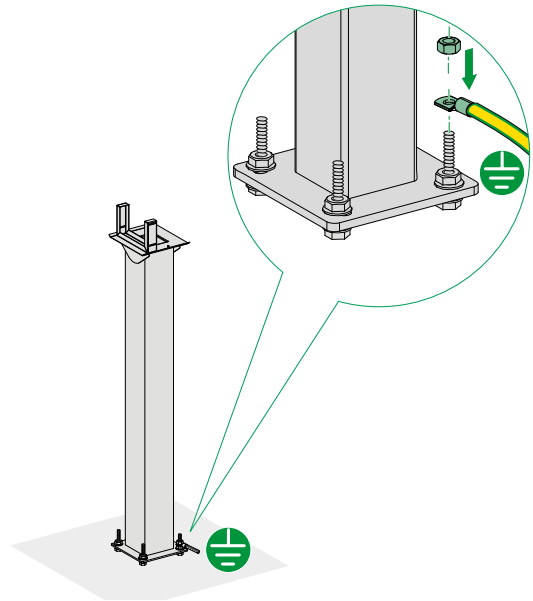

B

C

D

E

Positioning of the chargers (example using ProAC chargers)

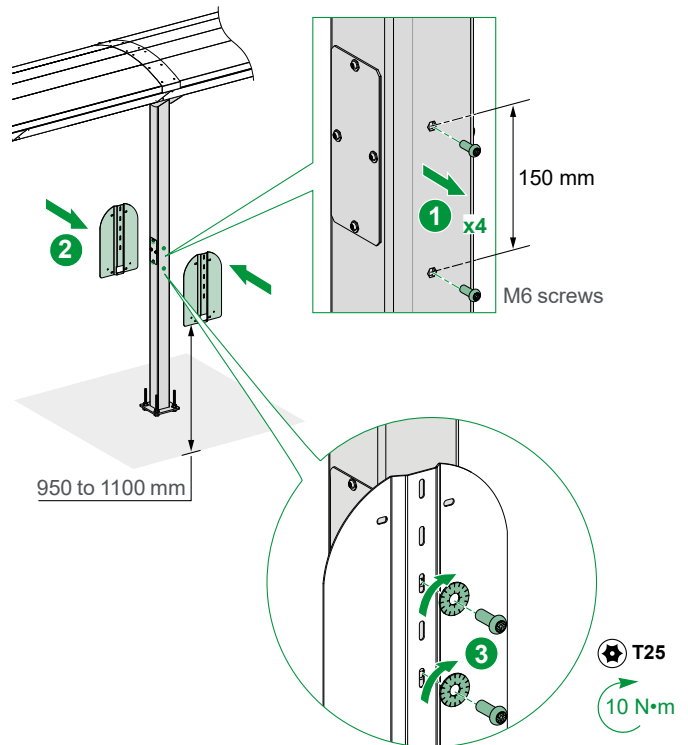

Installation rules and maintenance

Electrical power supplied directly into the canopy

- Feed pillar and its accessories are not required for installation
- EV charger pillar to be used instead of feed pillar
- Distance from Wall face to end cap edge should be minimum 200 mm
- Above 200 mm should be taken into consideration while preparing the foundation
- Hole on the end cap for the cable entry must be done by installer
- Gasket should not get damaged while drilling the end cap

Maintenance

Maintenance of the structure must be carried out once a year. Hardware torques, ventilation mesh cleaning, gaskets, and earthing continuity all need to be inspected during maintenance.

- Only the bottom ventilations are to be removed during maintenance (access to busbar trunking, tap-off units, and end feed units)
- Clean the bottom ventilation with a microfiber cloth, and vacuum cleaner to remove any remaining dust and dirt particles
- Avoid water jet cleaning on the bottom ventilation
- Keep the top of the canopy without accumulation of snow
- In case of replacement of roof parts use the recommended sealant and follow the instructions sheets.

Maintenance of the Canalis KS busbar trunking system has to be done by following the procedure of the respective Canalis KS catalogue DEBU026EN page 230.

A

B

C

D

E

Compare architectures

Power distribution

Centralized distribution with Cables

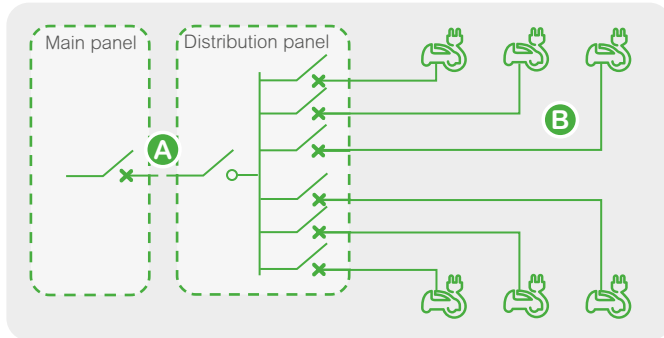

Decentralized distribution with Canalis

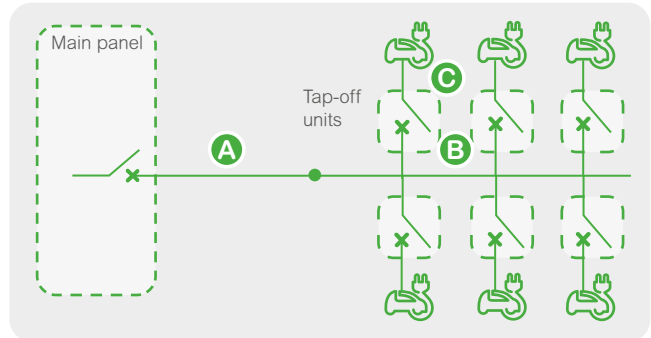

Centralized distribution with Cables	Decentralized distribution with Canalis
<ul style="list-style-type: none"> • Distribution panel + Switch-disconnector 	<ul style="list-style-type: none"> • Not required
<ul style="list-style-type: none"> • Resources = 132 kg of CU 	<ul style="list-style-type: none"> • Resources • 26 kg of AL • 25 kg of CU <p style="text-align: right;">- 62%</p>
<ul style="list-style-type: none"> • Insulation = 117 kg • Fire load = 936 kWh 	<ul style="list-style-type: none"> • Insulation = 17 kg • Fire load = 138 kWh <p style="text-align: right;">- 84%</p>

Studied case:

- Number of parking spaces: 16 (8+8), N = 8
- Parking spaces width: W = 2.5 m
- Chargers power: 22 kW 3P
- Diversity factor: 0.4

Centralized distribution:

- **B** Cable type: U-1000 R2V 5G10 (10 mm²)
- Cables length = $2x(Wx(Nx(N+1)/2)+NxV_1)$ = 297 m including an extra length to the panel and the chargers
V₁ = 4 m

Decentralized distribution:

- **B** Canalis KSA250 length = 18 m
- **C** Cables length = $2xNxV_2$ = 48 m 5G10 (10 mm²)
- with an extra length Canalis to chargers V₂ = 3 m

Chargers powered by Cables in trench

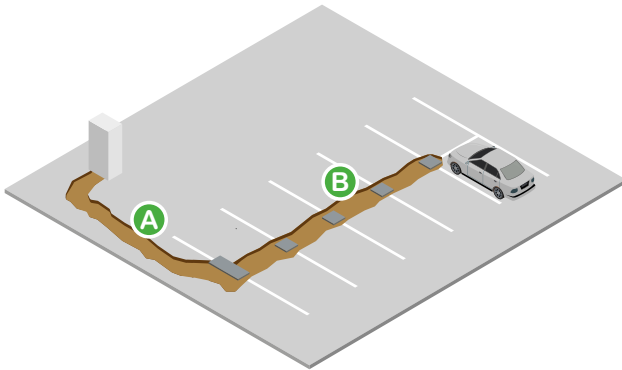

- Dig the main trench A
- Dig the trench B of 1 m x L m
- Install ground conduits + distribution boxes
- Cast concrete bases for the chargers and the switchboard

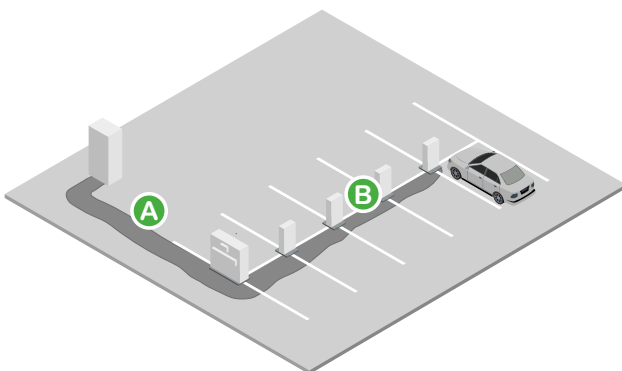

- Redo asphalt of main trench A
- Redo asphalt of the trench B 1 m x L m
- Redo painting
- Evacuate waste

Chargers powered by Canalis outdoor infrastructure

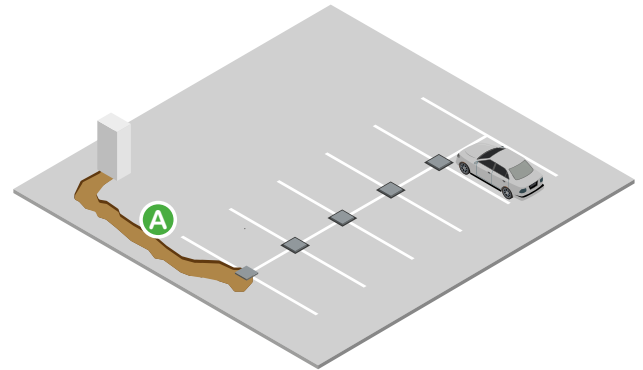

- Dig the main trench A
- Dig rectangle holes in asphalt with limited waste
- Cast concrete base for pillars

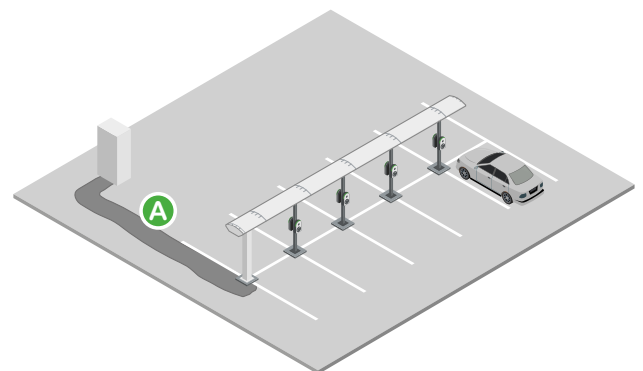

- Redo asphalt of main trench A

A

B

C

D

E



Description

Structure 28
Power distribution 31
Chargers..... 33



Description

Structure

Pillars

A



B

C

Charger Pillar

The charger pillars are made of 2 parts:

- Charger pillar: KEV0400CP2400B
- Charger pillar support: KEV0400TS1B

These parts are made of 4 mm painted steel sheet, color black RAL9005.

Charger pillars are playing two roles: supporting the canopy and supporting the chargers. Pillars can be installed on concrete base or prefabricated casted base thanks to a bottom plate.

The pillar is ready for the installation of the ProAC chargers from Schneider Electric using the charger support KEV0400CS. For other chargers, adaptation plates will have to be fixed with the pattern of insert nuts available on the pillar. Electrical connection from the Canalis tap-off unit internally through the pillar, visit windows are available to facilitate the caballing.

The bolts M12 to M18 to fix the pillars on the concrete bases are not supplied.

The charger support KEV0400CS1 is provided for one EVLink Pro AC charger.

In case of two chargers installed side-by-side or for any other types of chargers a local adaptation will be required.

The support plates must be made of aluminium or stainless steel.

Customised

Charger fixing plate - Material selection should be Aluminium or Stainless steel - chosen for its favourable strength-to-weight ratio, corrosion resistance, and compatibility with electrical installations)

- 20 kg to be considered on each side of pillar to mount the charger
- For 3rd party charger support must be provided based on the size and weight
- To mount two dual chargers on one side, side supports must be provided on pillars to ensure stability such that the weight should be evenly distributed.
- Overall weight of the charger fixing plate including the charger mounted on pillar should be maximum 80 kg.

D

E



End Feed Pillar

The feed pillars are made of 2 parts:

- Feed pillar: KEV0400EP2400W
- Feed pillar support: KEV0400ES1B

These parts are made of 4 mm painted steel sheet, color white RAL9003.

Feed pillars are playing two roles: supporting the canopy and Incoming cable routing. Pillar can be installed on concrete base or prefabricated casted base thanks to a bottom plate. A poka-yoke design controls the right orientation of the feed pillar and its support.

Two visit windows are available to facilitate the caballing.

The bolts M12 to M18 to fix the pillars on the concrete bases are not supplied.

All painted parts passed successfully the 1440 hours salt spray test.





Horizontal structure

The horizontal structure is composed of 3 types of parts:

- Side rails 1200 mm KEV0400SR1200
- Side rails 2400 mm KEV0400SR2400
- A set of two side brackets KEV0400SB1

These parts are made of 2.5 mm painted steel sheet, color black RAL9005.

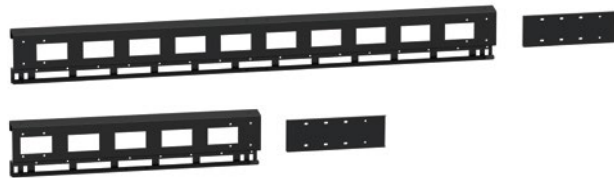

Side closure

The horizontal structure is composed of 3 types of parts:

- Side closure 1200 mm KEV0400SC1200W
- Side closure 2400 mm KEV0400SC2400W

These parts are made of 1 mm painted steel sheet, color white RAL9003.

Space available inside it to route the cable.

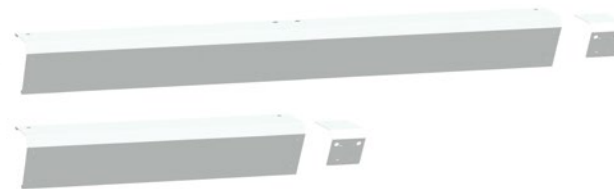

Canopy

The roof is composed of 4 types of parts:

- Top roof 1200 mm KEV0400TR1200W
- Top roof 2400 mm KEV0400TR2400W
- Top roof connection KEV0400CO1W
- A set of two end closures KEV0400EC1W

These parts are made of 1 mm painted steel sheet, color white RAL9003.

The roof connections and the end closure are equipped with foam gasket, however a sealing made a sealant cartridge is mandatory.

For storage reason the sealant is not part of the product provided by Schneider Electric and need to be order locally in a construction material store.



A

B

C

D

E

Description

Structure

Technical specifications

A

Mechanical and environmental characteristics

- Canopy and pillars are manufactured to withstand C5H corrosivity category
- C5H in the context of painting refers to a very high corrosivity category for steel structures, according to the ISO 12944 standard - It can withstand up to 1440 hours Salt spray test to exposed surface.
- All Hardware used are Stainless steel
- Degree of protection IP: suitable for outdoor use
 - IPX6 at Top roof of canopy - Rain and snow is completely blocked from entering the canopy
 - IP43 at bottom of canopy
 - IP4X Bottom of canopy is protected against the entry of solid objects larger than 1 mm
- IPX3 - Bottom of canopy can withstand water spray from any angle up to 60 degrees from vertical
- Impact protection code: IK10 entire structure
- Structure can withstand wind load upto 210 km/hr in any direction
- The structure is designed to withstand snow loads of up to 90 kg/m². (Curve shape of roof avoids accumulation of snow - wind and snow load is important to select foundation and it depends on region of installation).

B

C

D

E

Sealant specifications

- Temperature resistance: - 40°C to +80°C
- UV and weather resistant
- Application on metal surface
- Color: White
- Basic material: Silyl Modified Polymer (SMP)
- Recommended product: Bostik - SIMSON ISR 70-03.

Description

Power distribution

Canalis KS lines - 100 to 400 A

Distribution length

Components of the Classic offer are available in four ratings: 100, 160, 250 and 400 A.

Busbar trunking rated 100 to 400 A may be equipped with tap-off units up to 250 A. Higher rating busbar trunking elements may be equipped with the entire range of tap-off units. All the insulating and plastic materials are halogen-free and have enhanced fire-withstand capabilities (incandescent wire test as per standard IEC 60695-2: 960°C for components in contact with live parts and 650°C for other components).

The degree of protection of the busbar trunking is IP55 for indoor installations. For the sprinkler protection, it is necessary to add a specific sealing kit.

The basic structure of the line is made up of:



Casing, crimp closed, made of hot-galvanised sheet steel

Pre-lacquered RAL 9001 white, this casing, shaped and ribbed by roll-forming, provides excellent resistance to bending and twisting.

Conductors

For the 100 and 160 A rating: silver-plated aluminium/copper bimetal laminate.

For the 250 to 1000 A rating: aluminium bars equipped with silver-plated aluminium/copper bimetal laminate contacts electrically welded at junctions and tap-off points.

Protective conductor (PE)

Sized $\geq 50\%$ with respect to the cross-section of phases. It is connected to the casing at each junction.

Tap-off outlets

From 0.5 to 1 meter on both sides of the trunking.

Mechanical and electrical jointing system

Electrical jointing is ensured by a block with flexible grip contacts made of silver-plated copper. This block equally absorbs the difference in conductor and casing thermal expansion for each length.

For the 100 to 250 A rating, the jointing system ensures automatic and simultaneous jointing of all live conductors and the continuity of the protective earth conductor.

For the 400 A rating, electrical jointing is ensured by a quarter-turn locking mechanism for each conductor.



End feed unit

For KS 100 A trunking, it can be mounted on either side of a straight length. It is equipped with a PG 29 cable gland (equivalent to M32) and supplied with an end cover.

For 250 to 400 A rating, it can be mounted on either side of a straight length. Supplied with an end cover.

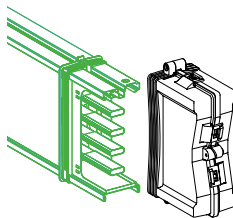

End cover

The end cover protects and isolates the ends of the conductors. It is mounted on the last component. Supplied with all feed units.

Description

Power distribution

Canalis KS Tap-off units - 25 to 100 A

Tap-off units for circuit breakers (not included)

Tap-off unit covers can be lead sealed to prevent circuit breaker switching by unauthorised persons.



KSB32CM55



KSB63SM48



KSB100SM412

Connector for modular devices

Type CM

This connector can be equipped with most modular devices (18 mm wide) of the Acti 9 type:

- rated current: 32 A
- capacity: 5 modules
- with a window in front for visual and physical access to the devices.

Tap-off units, with isolators, for modular devices

Type SM

These tap-off units accept most modular devices of the Acti9 type available in multiples of 18 mm wide modules. They have a window in front for visual and physical access to the devices. Two ratings are available:

- rated current 63 A for eight modules
- rated current 100 A for twelve modules (can accept C120 circuit breakers).

Examples of Canalis KS equipped tap-off units

Canalis KS tap-off unit
KSB63SM48

MCB



RCD

2-pole and 4-pole pre-assembled and pre-cabled kits for 1 x 8-module tap-off unit

- 1 x circuit breaker
- 1 x RCD B-type for electric vehicle applications.



Charging station power	Description of the Protection kit	Included	References		
			MCB	RCD	Kit
7.4	Canalis KS 8 mod. 2P MCB 40 A RCD B EV	Tap-off unit KSB63SM48	A9F07240	A9Z51240	EVK8KS2PB40
11	Canalis KS 8 mod. 4P MCB 25 A RCD B EV		A9F07420	A9Z51425	EVK8KS4PB25
22	Canalis KS 8 mod. 4P MCB 40 A RCD B EV		A9F07440	A9Z51440	EVK8KS4PB40



> ROHS compliant
> Reach compliant
> EoL: End Of Life Process
> Product Environmental Profile compliant

Certification

EVlink Pro AC has been certified according to the IEC 61851-1 ed3.0 standard by the DEKRA certification body

Standards

IEC/EN 61851-1 Ed 3.0
IEC/EN 62196-1 Ed 2.0 - IEC/EN 62196-2 Ed 1.0
IEC 60364-7-722 Ed.2
EMC IEC 61851-21-2
EMC EN 301 489-1 V2.1.1 - EN 301 489-17 V3.1.1
Upgradable to ISO 15118 Plug and Charge
EV Ready

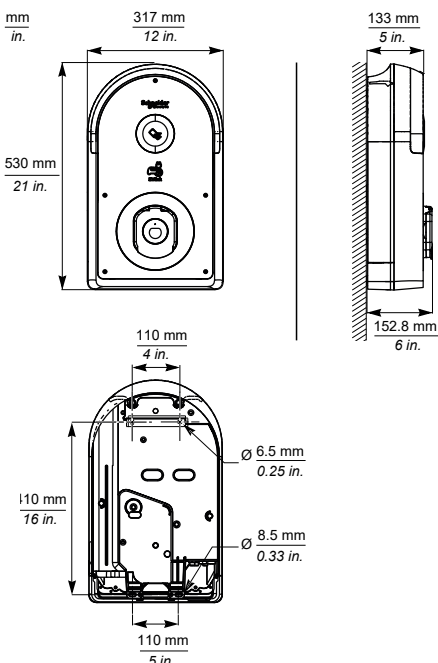

Power supply network

- 220 - 240 V AC single-phase – 50/60 Hz for 7.4 kW charging stations
- 380 - 415 V AC three-phase – 50/60 Hz for 11 and 22 kW charging stations

Earthing system

- TT, TN-S, TN-C-S
- 3 phases versions with embedded RCD (A or B) are not compliant with single phase distribution or 3 x 230 V AC (ph-ph) distribution
- EVlink Pro AC is compatible with IT single-phase network only, and is not compatible with 400 V 3-phase IT network

Rated charging current

- T2S socket outlet with shutters and silver-plated contacts: 16 A to 32 A (factory setting: 32 A)
- TE or TF domestic socket-outlet: 10 A
- T2 attached cable, length 5 meters: 16 A to 32 A
- Socket-outlet on the front

Mechanical and environmental characteristics

- Ingress protection code: suitable for indoor and outdoor use
 - IP55 with T2S socket-outlet
 - IP55 with attached cable
 - IP54 with domestic socket
- Impact protection code: IK10
- Ambient air temperature for operation: -30°C to +50°C (+40°C for EVlink Pro AC with embedded RCD type Asi)
- Ambient air temperature for storage: -40°C to +80°C (+70°C for EVlink Pro AC with embedded RCD type Asi)
- Energy management options:
 - via digital inputs: limited current, postponed/suspended charge,
 - dynamic energy management combined with TIC interface with French utility meter or universal energy meter
- EV presence detection via digital input

Access control modes

- Free access
- User authentication through RFID or NFC badge
 - NFC 13.56 MHz reader compatible with type 1, 2, 4 and 5 badges
 - RFID reader:
 - conforming to ISO/IEC 14443 A and B and ISO/IEC 15693 protocols,
 - compatible with Mifare Ultralight, Mifare Classic, Mifare Plus

Embedded protection and metering

(depending on commercial references)

- Earth leakage protection: RDC-DD 6 mA + RCD type Asi 30 mA or RCD type B-EV
- Undervoltage tripping auxiliary MNx
- MID energy meter
- Metering board and CTs 1% accuracy

Easy to install and commission

- Wall mounting or floor standing
- 1 or 2 charging stations on the same pedestal
- Parameter setting through eSetup app via Bluetooth or EcoStruxure EV Charging Expert

Versatile connection to a supervision

- Wired Ethernet: 2 ports (1 for daisy chain)
- Connection through embedded or external 3G/4G modem as an accessory
- OCPP 1.6 Json Smart Charging interface

Services

- Worldwide customer care center
- Additional 1- or 3-year Warranty Extension
- On-site or remote commissioning support
- Services Plan
- Schneider Electric manufactured spare parts
- Advanced on-site training
- Worldwide network of partners providing on-site installation, commissioning and maintenance services

Description

Chargers

EVlink Pro AC

Charging station commercial references

Commercial references (1) (2) (7)	Type of socket	Domestic socket	Output current	Power kW	Number of phases	Embedded protection	Embedded protection (4)	Protection supplied	Embedded MID meter (6)
EVB3S07NC0	Att T2 (5)	-	32 A	7.1	1PH	RDC-DD 6 mA	MNx	-	-
EVB3S07N40M	T2S	-	32 A	7.4	1PH	RDC-DD 6 mA	MNx	-	Yes
EVB3S07N40EM	T2S	TE	32 A	7.4	1PH	RDC-DD 6 mA	MNx	-	Yes
EVB3S07N4AM	T2S	-	32 A	7.4	1PH	RDC-DD 6 mA + RCD Asi 30 mA	MNx	-	Yes
EVB3S07N4EAM	T2S	TE	32 A	7.4	1PH	RDC-DD 6 mA + RCD Asi 30 mA	MNx	-	Yes
EVB3S07NCAM	Att T2 (5)	-	32 A	7.4	1PH	RDC-DD 6 mA + RCD Asi 30 mA	MNx	-	Yes
EVB3S07N4A	T2S	-	32 A	7.4	1PH	RDC-DD 6 mA + RCD Asi 30 mA	MNx	-	-
EVB3S07N4EA	T2S	TE	32 A	7.4	1PH	RDC-DD 6 mA + RCD Asi 30 mA	MNx	-	-
EVB3S07NCA	Att T2 (5)	-	32 A	7.4	1PH	RDC-DD 6 mA + RCD Asi 30 mA	MNx	-	-
EVB3S07N4E1	T2S	TE	32 A	7.4	1PH	RDC-DD 6mA	-	-	-
EVB3S07N41	T2S	-	32 A	7.4	1PH	RDC-DD 6mA	-	-	-
EVB3S11N4A	T2S	-	16 A	11	3PH	RDC-DD 6 mA + RCD Asi 30 mA	MNx	-	-
EVB3S11NCA	Att T2 (5)	-	16 A	11	3PH	RDC-DD 6 mA + RCD Asi 30 mA	MNx	-	-
EVB3S11N4FB	T2S	TF	16 A	11	3PH	RCD B EV	MNx	-	-
EVB3S22NC0	Att T2 (5)	-	32 A	22	3PH	RDC-DD 6mA	MNx	-	-
EVB3S22N4	T2S	-	32 A	22	3PH	RDC-DD 6 mA	MNx	-	-
EVB3S22N4E	T2S	TE	32 A	22	3PH	RDC-DD 6 mA	MNx	-	-
EVB3S22N4A	T2S	-	32 A	22	3PH	RDC-DD 6 mA + RCD Asi 30 mA	MNx	-	-
EVB3S22NCA	Att T2 (5)	-	32 A	22	3PH	RDC-DD 6 mA + RCD Asi 30 mA	MNx	-	-
EVB3S22N4EA	T2S	TE	32 A	22	3PH	RDC-DD 6 mA+ RCD Asi 30 mA	MNx	-	-
EVB3S22N4B	T2S	-	32 A	22	3PH	RCD B EV	MNx	-	-
EVB3S22NCB	Att T2 (5)	-	32 A	22	3PH	RCD B EV	MNx	-	-
EVB3S22N4EB	T2S	TE	32 A	22	3PH	RCD B EV	MNx	-	-
EVB3S22N4FB	T2S	TF	32 A	22	3PH	RCD B EV	MNx	-	-
EVB3S22N4E1	T2S	TE	32 A	22	3PH	RDC-DD 6mA	-	-	-
EVB3S22N41	T2S	-	32 A	22	3PH	RDC-DD 6mA	-	-	-
EVB3S22N40M	T2S	-	32 A	22	3PH	RDC-DD 6 mA	-	-	Yes
EVB3S22N40EM	T2S	TE	32 A	22	3PH	RDC-DD 6 mA	-	-	Yes
EVB3S22N40FM	T2S	TF	32 A	22	3PH	RDC-DD 6 mA	-	-	Yes
EVB3S22NC0M	Att T2 (5)	-	32 A	22	3PH	RDC-DD 6 mA	-	-	Yes
EVB3S22N40MR (3)	T2S	-	32 A	22	3PH	-	-	RCD B EV+MNx	Yes

1) Cable for T2S charger available as an accessory

(2) Includes 1 RFID badge

(3) Recommended for metallic charger, this specific charging station only measures the power consumption of the electric vehicle

(4) An MNx under voltage tripping auxiliary is mandatory in case of charging station damage following a downstream short circuit

(5) Attached cable with T2 connector

(6) MID certified energy meter, IEC accuracy class 1, B (active)

(7) All 3-phase references can be wired as 1-phase except those with embedded RCDs

Protections with EVlink Pro AC

Description			
Charging	Single-phase		Three-phase
Rated Power - Current	7.4 kW - 32 A (2)		11 kW - 16 A (2) 22 kW - 32 A (2)
Protection			
Circuit breaker (overcurrent) (1)	40 A Curve C		20 A Curve C 40 A Curve C
Delayed start			
Relay	With normally open contact (3)		
Temporary current limitation			
Relay	With normally open contact (3)		

(1) References to be defined and local availability to be checked by Schneider Electric front offices.

(2) With or without domestic socket.

(3) EVlink Pro AC setting can be changed to "normally closed" if necessary, with the eSetup commissioning app.

A

B

C

D

E

GLOBAL

Zones and outlets

ZONES

All zones

1st Floor

1st Floor - North

1st Floor - South

2nd Floor

3rd Floor (VIP)

POWER OUTLETS

All power outlets

PowerMeter1

EXPORT TRANSACTIONS

INFORMATION

DASHBOARD

Station fleet

Stations 23

Cluster power repair

Charge points 39

- available 32
- charging 3
- suspended by EV 1
- suspended by system 1
- faulted 2
- not connected 0
- unavailable 0



Charges

Optimal	0
Reduced	0
Suspended	0

CHARGES

0

charging stations local production

STATIONS

Name	Zone	Connector	Status
Station 17	2nd Floor - North-East	1	available
Station 18	2nd Floor - North-East	1	available
Station 19	2nd Floor - North-East	1	available
Station 20	2nd Floor - North-East	1	available
Station 21	2nd Floor - North-East	1	available
Station 22	2nd Floor - North-East	1	available
Station 23	2nd Floor - North-West	1	charging
Station 24	2nd Floor - North-West	1	available
Station 25	2nd Floor - North-West	1	available
Station 26	2nd Floor - North-West	1	charging

Catalog Numbers and Dimensions

Structure	38
Pillars	38
Canopy	39
Accessories	42
Power distribution	44
Canalis KS line components	44
Canalis KS Tap-off units.....	45



Catalog Numbers and Dimensions

Structure Pillars

EP/ES - End feed pillar and support - White RAL 9003

A



KEV0400ES1B

Height (mm)	Description	Catalogue number	Weight (Kg)
2400	1 end feed pillar	KEV0400EP2400W	82.8
-	1 end feed pillar top support	KEV0400ES1B	4.3

B



KEV0400EP2400W

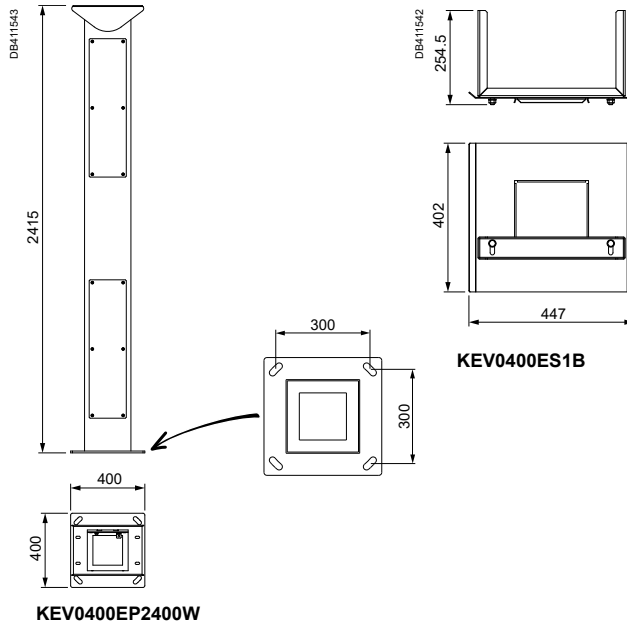

C

D

CP/TS - Charger pillar and supports - Black RAL 9005

E



KEV0400TS1B

Height (mm)	Description	Catalogue number	Weight (Kg)
2400	1 charger pillar	KEV0400CP2400B	74.4
-	1 charger pillar top support	KEV0400TS1B	14.2



KEV0400CP2400B

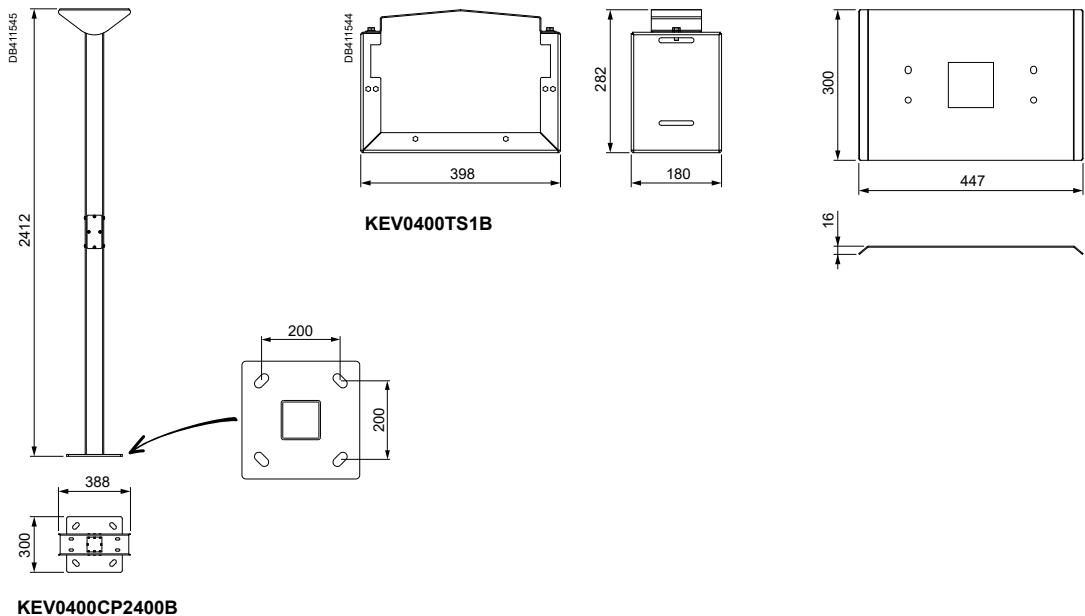

A

B

C

D

E

SR - Side rails



KEV0400SR2400



KEV0400SR1200

Height (mm)	Description	Catalogue number	Weight (Kg)
2400	1 set of 2 side rails L = 2400 (including connection plates and bolts)	KEV0400SR2400	82.2
1200	1 set of 2 side rails L = 1200 (including connection plates and bolts)	KEV0400SR1200	45.5

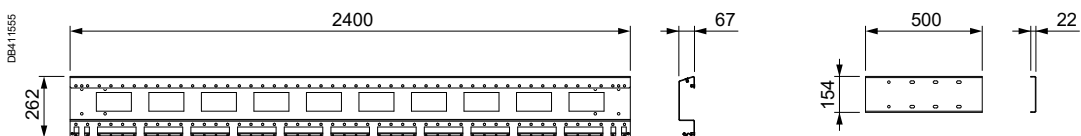

KEV0400SR2400

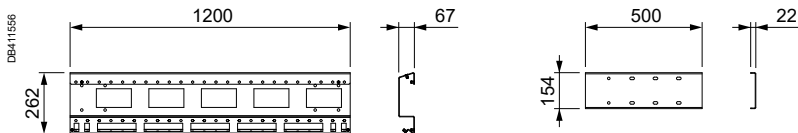

KEV0400SR1200

SC - Side Closure - White RAL 9003



KEV0400SC2400W



KEV0400SC1200W

Height (mm)	Description	Catalogue number	Weight (Kg)
2400	1 set of 2 side rails L = 2400 (including connection plates and bolts)	KEV0400SC2400W	43.6
1200	1 set of 2 side rails L = 1200 (including connection plates and bolts)	KEV0400SC1200W	22.9

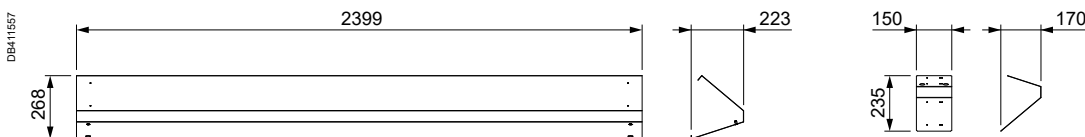

KEV0400SC2400W

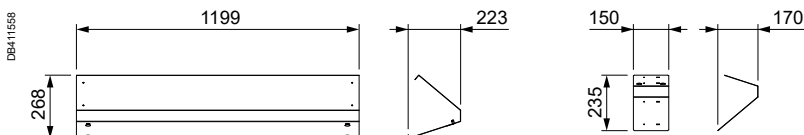

KEV0400SC1200W

Catalog Numbers and Dimensions

Structure

Canopy

TR/CO - Top roof + connection - White RAL 9003

A



Length (mm)	Description	Catalogue number	Weight (Kg)
2400	1 top roof L = 2400	KEV0400TR2400W	18.4
1200	1 top roof L = 1200	KEV0400TR1200W	18.5
-	1 top roof connection including rivets	KEV0400CO1W	3.1

B



C

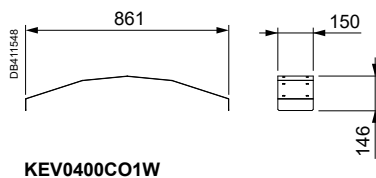
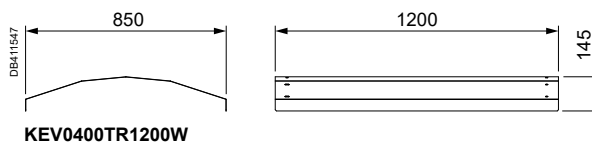
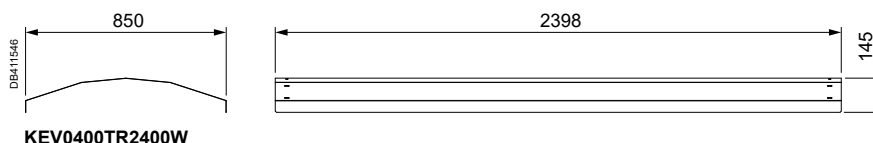

D

EC - End closure - White RAL 9003

E



Description	Catalogue number	Weight (Kg)
1 set of 2 end closures including bolts	KEV0400EC1W	5.3

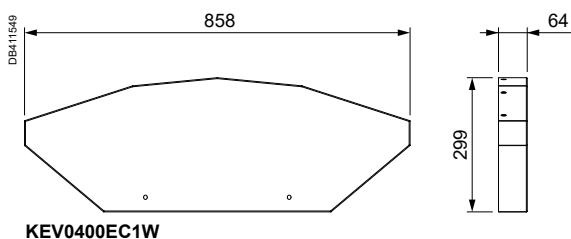

A

B

C

D

E

BV - Bottom ventilation - Black RAL 9005



KEV0400BV1B

Length (mm)	Description	Catalogue number	Weight (Kg)
2400	1 set of 3 overlapping bottom ventilation plates including bolts	100 to 400 A KEV0400BV1B	13.2

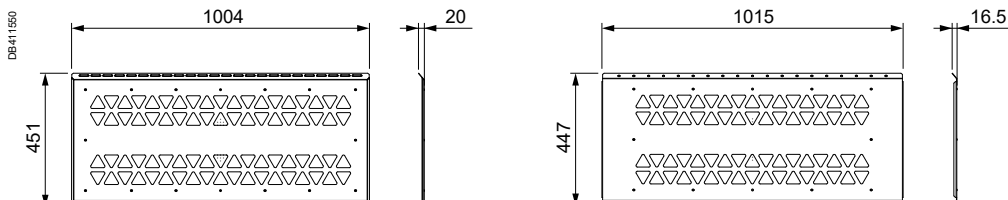

KEV0400BV1B

BP - Adjustable bottom plate - Black RAL 9005



KEV0400BP1000B

Length (mm)	Description	Catalogue number	Weight (Kg)
200 to 1000	1 adjustable bottom plate for extremities including bolts	100 to 400 A KEV0400BP1000B	1.7

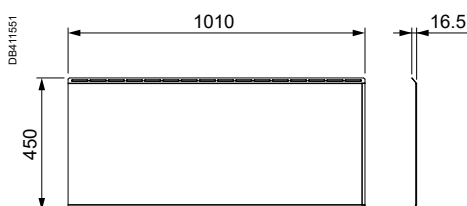

KEV0400BP1000B

SE - Support plate



KEV0400SE1

Description	Catalogue number	Weight (Kg)
1 support plate for Canalis KS bracket	100 to 400 A KEV0400SE1	1.6

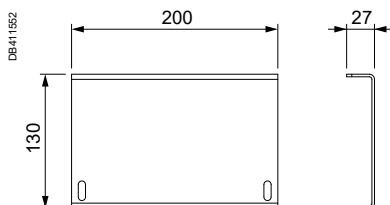

KEV0400SE1

SB - End feed unit fixing plates

KEV0400FP1



KEV0400FP1

Description	Catalogue number	Weight (Kg)
1 set of fixing plates for Canalis KS end feed unit	100 to 400 A KEV0400FP1	5

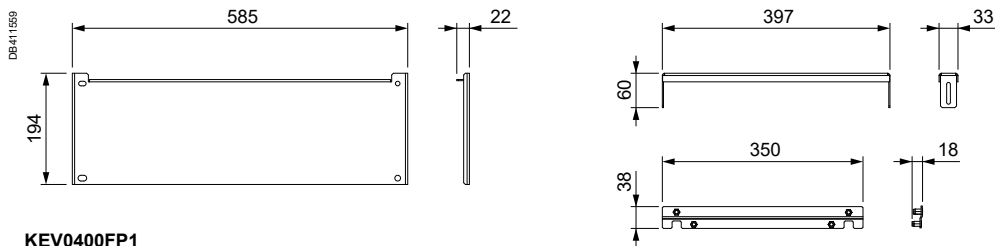

KEV0400FP1

SB - Side bracket

KEV0400SB1



KEV0400SB1

Description	Catalogue number	Weight (Kg)
1 set of 2 side brackets to connect side rails at the extremities	100 to 400 A KEV0400SB1	2.2

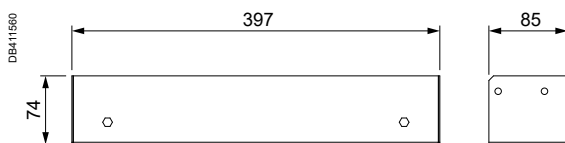

KEV0400SB1

A

B

C

D

E

FS - Intermediary free support



KEV0400FS1

Description	Catalogue number	Weight (Kg)
1 intermediary free support including bolts	100 to 400 A KEV0400FS1	6

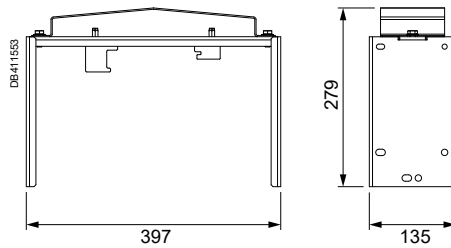

KEV0400FS1

CS - Pro AC Charger support - Black RAL 9005



KEV0400CS1

Description	Catalogue number	Weight (Kg)
1 support for charger pro AC Schneider Electric	100 to 400 A KEV0400CS1	3.1

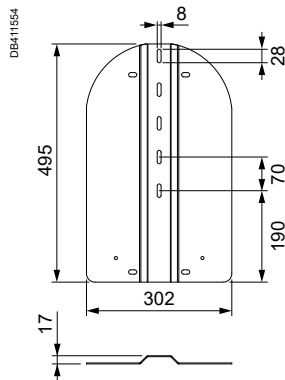

KEV0400CS1



Power distribution

Canalis KS line components

ED - Straight horizontal distribution - IP55 - 3L+N+PE

A



Length (mm)	Outlet nb		Catalogue number			
	Front	Rear	100 A	160 A	250 A	400 A
3000	6	6	KSA100ED43012	KSA160ED43012	KSA250ED43012	KSA400ED43012
2000	4	4	▶	▶	KSA250ED4208	KSA400ED4208

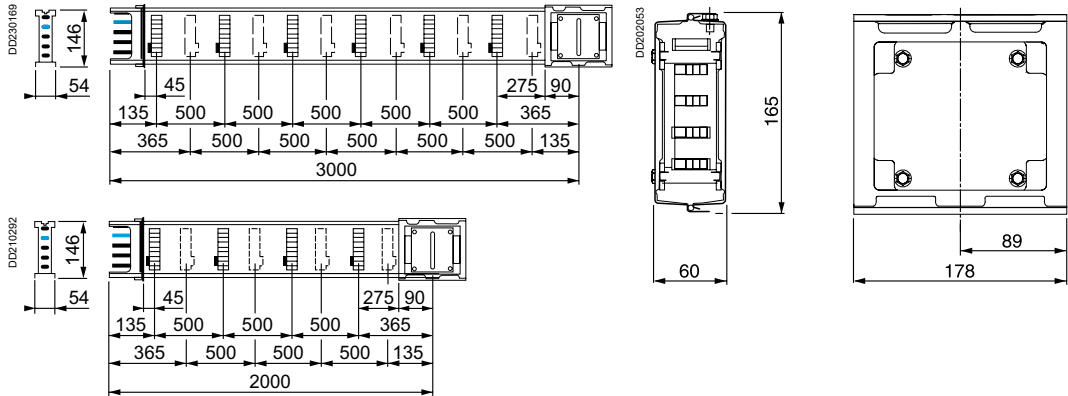

B

C

AB - Cable box feed unit - Right or left mounting - IP55

D



KSA100AB4



KSA250 and 400 AB4

Type	Mounting	Catalogue number			
		100 A	160 A	250 A	400 A
Fixed	Right or left	KSA100AB4	▶	KSA250AB4	KSA400AB4
Additional information					
Connection		Terminals	-	Lugs (M10 screws)	Lugs (M10 screws)
Max. Cable size (mm ²)		max Ø23 mm	-	4 x 240	4 x 300 or 8 x 120

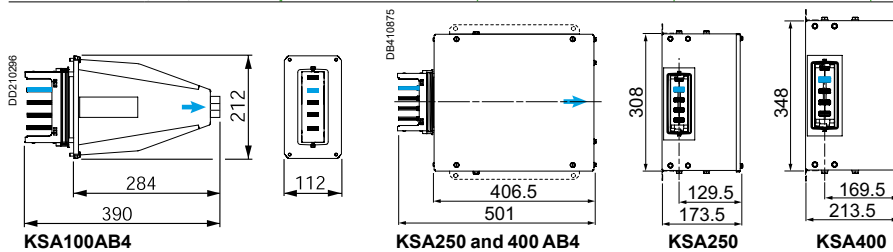

E

EZ - Universal and rear fixing brackets



KSA80EZ5

Catalogue number	
400 A	
KSA80EZ5	
Compatible with	KSA100 to 400
Max load	50 kg
Selling Unit	1
Order in multiples of	10

Maximum recommended distance between fixings is 2 meters.

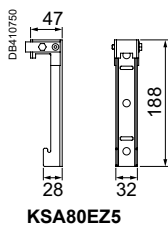

▶ No dedicated reference for this rating. Select the first above available reference

Catalog Numbers and Dimensions

Power distribution

Canalis KS Tap-off units

A

B

C

D

E

CM - Tap-off units without Power sockets



KSB32CM55

Polarity	Catalogue number
3L + N + PE 	32 A KSB32CM55
Nb of modules (18 mm)	5
Compatible with	KSA100 to 1000 and KSC160 to 800

Delivered equipped with a DIN rail.
For 18 mm modular devices.

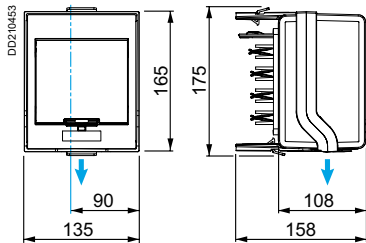

SM - Tap-off units for modular devices



KSB63SM48



KSB100SM412

Polarity	Catalogue number	
3L + N + PE 	63 A KSB63SM48	100 A KSB100SM412

Disconnection by opening the door.
Delivered equipped with a DIN rail.
Silver-plated copper terminals (M6) for Copper compression lugs.

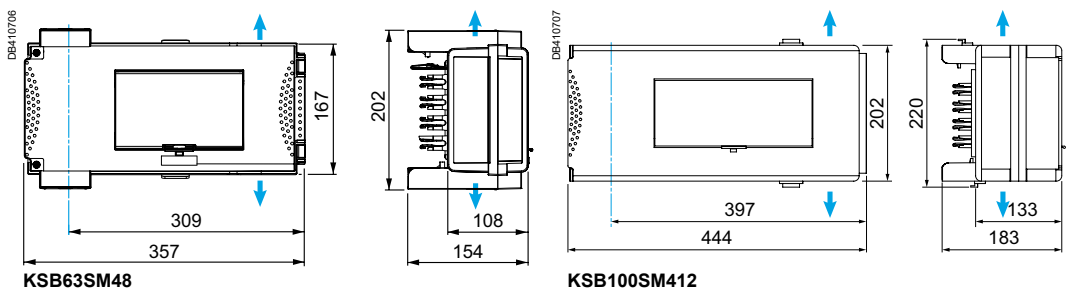



Cat. numbers	Description	Page
KEV - Structure		
KEV0400EP2400W	CANALIS EV 1 X FEED PILLAR 2400 WHITE	34
KEV0400ES1B	CANALIS EV 1 X FEED PILLAR SUPPORT BLACK	34
KEV0400CP2400B	CANALIS EV 1 X CHARGER PILLAR 2400 BLACK	34
KEV0400TS1B	CANALIS EV 1 X CHARGER PILLAR SUPPORT BL	34
KEV0400SR2400	CANALIS EV 2 X SIDE RAILS 2400	35
KEV0400SR1200	CANALIS EV 2 X SIDE RAILS 1200	35
KEV0400SC2400W	CANALIS EV 2 X SIDE CLOSURES 2400 WHITE	35
KEV0400SC1200W	CANALIS EV 2 X SIDE CLOSURES 1200 WHITE	35
KEV0400TR2400W	CANALIS EV 1 X TOP ROOF 2400 WHITE	36
KEV0400TR1200W	CANALIS EV 1 X TOP ROOF 1200 WHITE	36
KEV0400CO1W	CANALIS EV 1 X TOP ROOF CONNECTION WHITE	36
KEV0400EC1W	CANALIS EV 2 X END CLOSURES WHITE	36
KEV0400BP1000B	CANALIS EV 1 X BOTTOM PLATE 1000 BLACK	37
KEV0400BV1B	CANALIS EV 1 SET OF VENTILATIONS BLACK	37
KEV0400FP1	CANALIS EV 1 SET OF FIXING PLATES FOR AB	38
KEV0400SB1	CANALIS EV 2 X SIDE BRACKETS	38
KEV0400FS1	CANALIS EV 1 X INTERMEDIARY FREE SUPPORT	39
KEV0400CS1	CANALIS EV 1 X PRO AC CHARGER SUPPORT	39
KEV0400SE1	CANALIS EV 1 X SUPPORT PLATE	37
KSA/KSB - Canalis line components and tap-off units		
KSA100ED43012	STRAIGHT DISTRIBUTION LENGTH 3M 100 A	40
KSA160ED43012	STRAIGHT DISTRIBUTION LENGTH 3M 160 A	40
KSA250ED43012	STRAIGHT DISTRIBUTION LENGTH 3M 250 A	40
KSA400ED43012	STRAIGHT DISTRIBUTION LENGTH 3M 400 A	40
KSA250ED4208	STRAIGHT DISTRIBUTION LENGTH 2M 250 A	40
KSA400ED4208	STRAIGHT DISTRIBUTION LENGTH 2M 400 A	40
KSA100AB4	END FEED BOX 100 A	40
KSA250AB4	END FEED BOX 250 A	40
KSA400AB4	END FEED BOX 400 A	40
KSA80EZ5	FIXING BRACKET	40
KSB32CM55	CONNECTOR 32A 5 MODULES	41
KSB63SM48	TAP OFF UNIT 63A 8 MODULES	41
KSB100SM412	TAP OFF UNIT 100A 12 MODULES	41

Life Is On | **Schneider**
Electric

Schneider Electric Industries SAS

35, rue Joseph Monier
CS 30323
92506 Rueil Malmaison Cedex
France

RCS Nanterre 954 503 439
Capital social 896 313 776 €
www.se.com

10-2025
DEBU039EN

© 2025 - Schneider Electric. All Rights Reserved.
All trademarks are owned by Schneider Electric Industries SAS or its affiliated companies.