



Line Series

# Canalis KTA 800 - 5000 A

Catalogue 2026

Busbar trunking systems

Aluminium

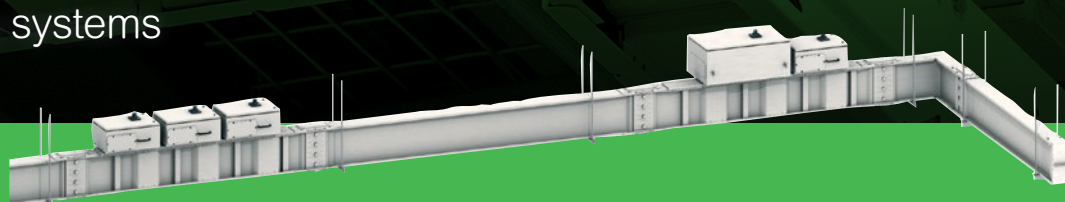

[se.com](https://se.com)

**Schneider**  
Electric



# Environmental Data Program

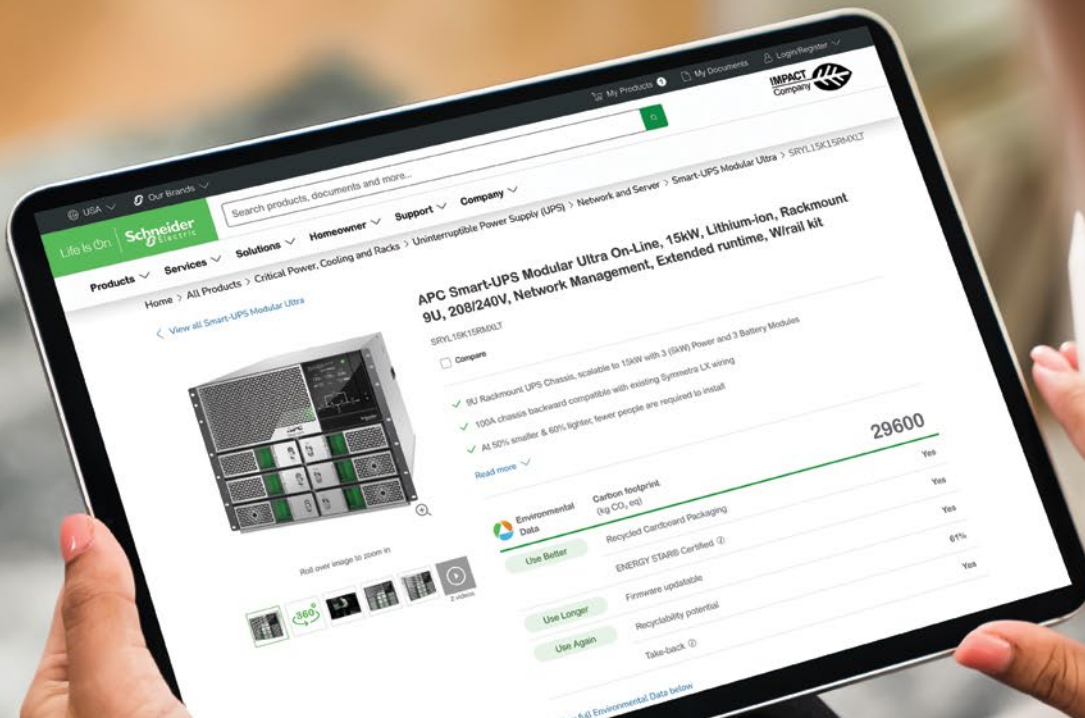

## Next-level transparency for better-informed product choices

The Environmental Data Program is a framework for how we measure, categorize, and compare the environmental attributes and footprint of our products.

Using a rigorous, fact-based methodology, the program provides environmental data from across the product lifecycle.

### Five data categories across the product lifecycle

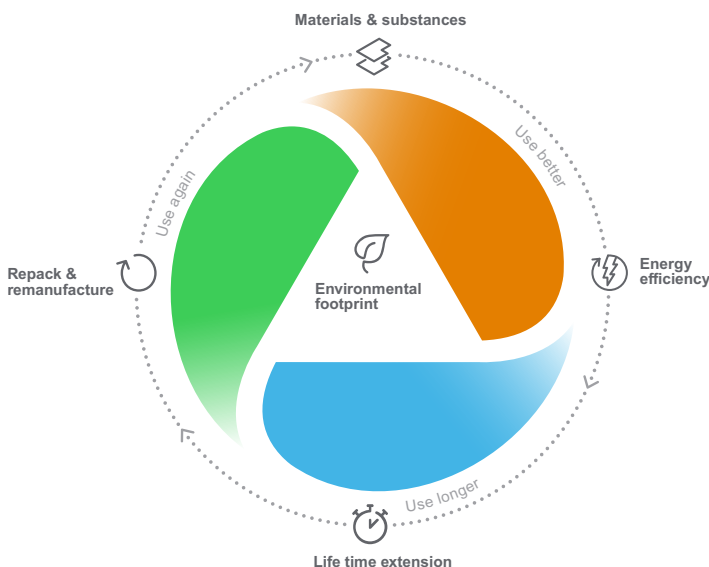

**Use Better:** How sustainable a product is, including environmental footprint, materials and substances, packaging, and energy efficiency.

**Use Longer:** How a product's life time can be effectively extended in terms of repairability and updatability.

**Use Again:** How a product can be reused, from dismantling and remanufacturing to recyclability and manufacturer take back.

With this transparent, verified data, customers and partners are empowered to make conscious environmental choices and accurately evaluate and report on sustainability performance.

All our hardware offers have an associated environmental data available on se.com product pages.



Learn more about the **Environmental Data Program**

# General Contents

## Canalis KTA

Introduction

A

Presentation and description

B

Catalogue numbers and dimensions

C

Design guide

D

Installation guide

E

Recommendations

F

Index

G



# Canalis the ideal offer to match with your needs

P68960-90



+ 70,000

More than 70,000 km of Canalis busbar trunking has been sold around the world.

## A total coordination with the Schneider Electric system

- Canalis is part of a comprehensive offering of Schneider Electric products designed to operate together.
- It guarantees and enhances the safety of people and equipment, and provides installation continuity of service, upgradeability and simplicity.
- This concept covers all low voltage electrical distribution components.
- The result is an optimised electrical installation with even higher performance through full electrical, mechanical and communication compatibility.
- It is perfectly suited to traditional applications (factories, warehouses, etc.) and to the distribution of electrical power from the incoming transformer on through to all types of loads in offices, commercial premises, laboratories, etc.

PD202088-104\_J

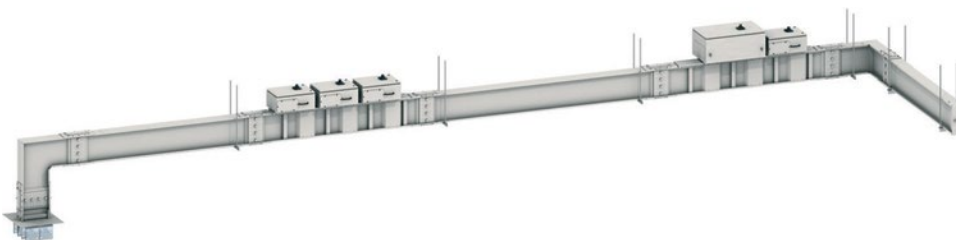

## Canalis KT provides you...

- ... more flexibility.
- ... ease of connection with the "plug and play" transformer and switchboard connections.
- ... more assistance with our teams ready to assist you throughout your project.

- A
- B
- C
- D
- E
- F
- G

## Introduction

# A Canalis installation for every distribution system

Schneider Electric offers different distribution systems to fit all your operating needs.

A

B

C

D

E

F

G

DB410747.eps

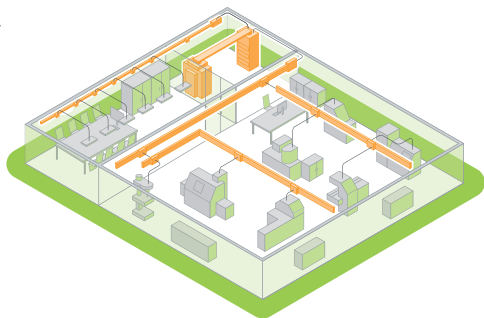

### Decentralized distribution

#### For manufacturing industries

- Mechanical
- Textiles
- Lumber
- Injection moulding
- Electronics
- Pharmaceuticals
- Livestock, etc.

#### Decentralized distribution lets you

- Design installations without layout details
- Upgrade without shutting down production
- Get systems up and running sooner thanks to faster installation
- Generate savings depending on the number of loads.

DD40505.eps

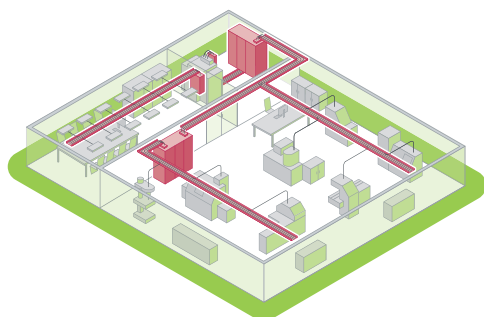

### Centralized distribution

#### For all continuous processes

- Cement plants
- Oil and gas
- Petrochemicals
- Steel
- Paper, etc.

#### Centralized distribution offers

- Continuity of service
- Combined distribution of power, control and monitoring circuits
- Supervision, etc.

DB410746.eps

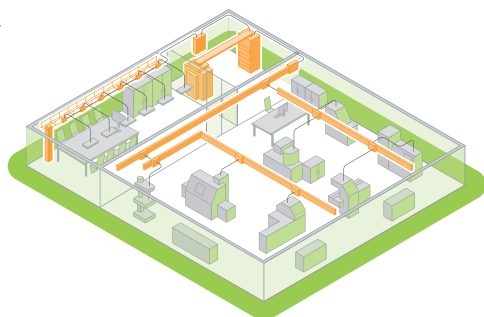

### Combined distribution

Where the advantages of both centralized and decentralized distribution are required.

#### Commercial and service buildings

- Offices
- Stores
- Hospitals
- Exhibition halls, etc.

#### Infrastructures

- Airports
- Telecommunications
- Internet data centres
- Tunnels, etc.

#### Industrial facilities

- Pharmaceuticals
- Food processing, etc.

# The Canalis decentralized distribution concept

## Electrical power available at all points within the installation

Total coordination of the Schneider Electric system provides maximum safety of life and property, continuity of service, upgradeability and ease of installation.

Total coordination is made easy by the tables in the "Design Guide". They help you choose the right combination of circuit breakers and busbar trunking. Product characteristics are verified by calculations and tests carried out in our laboratories.



Exclusive features of the Schneider Electric system

### A competitive installation

Simplicity, upgradeability, safety and continuity of service and operation.

**Savings start as soon as the installation begins.** With multiple tap-off points at regular intervals, Canalis busbar trunking reduces installation costs.

Given the low cost of adding new circuits, savings increase as the number of loads increase, a natural consequence of the growth of your business.

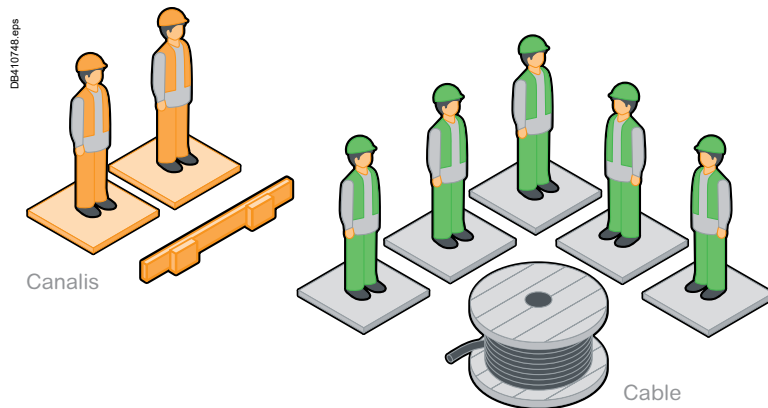

### Comparative investment

of 400 A electric power system equipment.

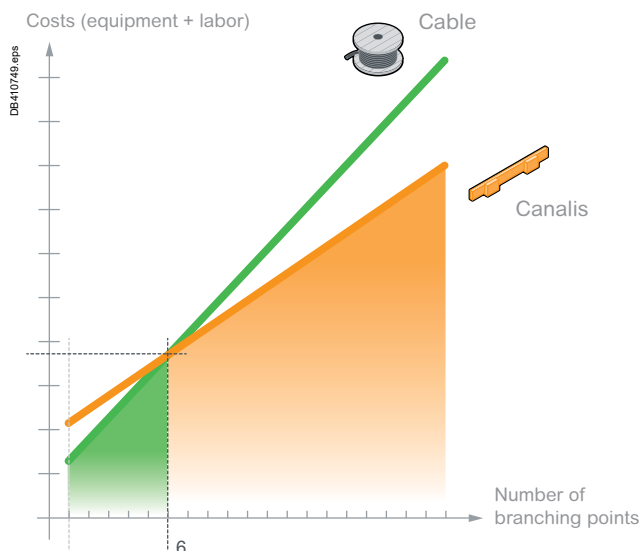

- A
- B
- C
- D
- E
- F
- G

## Introduction

# The Canalis decentralized distribution concept

A

B

C

D

E

F

G

### Upgradeable during operation

In decentralized distribution, evolving operating requirements and costs are integrated right from the start.

- The addition, relocation or replacement of load equipment can be carried out quickly, without de-energizing the supply trunking or shutting down operation.
- The cost of making such changes is greatly reduced:
  - loads are located close to supply points
  - tap-off points are always available
  - tap-units can be reused or new ones added quickly for load.

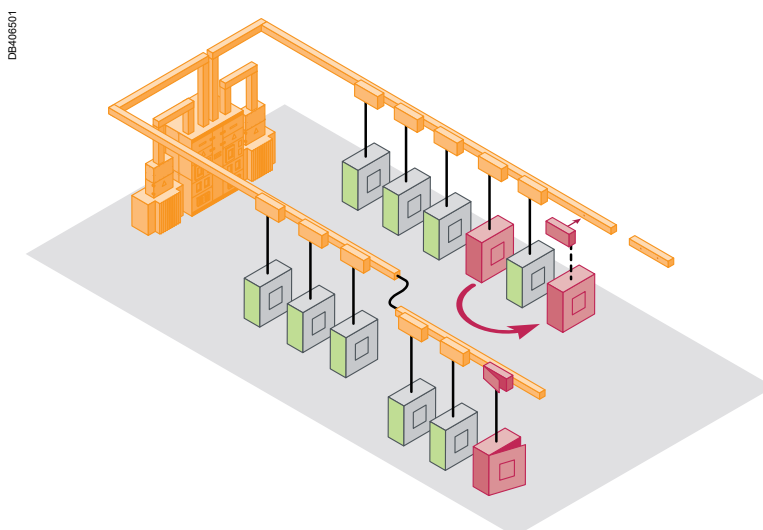

### Reusable in the event of major changes

When making major modifications to your installation, the existing trunking can be easily dismantled and reused.

Power distribution is a major challenge in the construction and refurbishment of commercial, industrial buildings and data centers.

The choice of device is fundamental as it will have an effect on the building's lifecycle. Infrastructures must comply with existing requirements while being flexible, networked and smart. The Canalis concept is undoubtedly the best solution to meet the needs of today and the challenges of tomorrow.

## Simple to estimate

**Designing Canalis installations is straightforward** as there is no need to know the exact location, nor the power rating of the loads to be supplied.

**It is therefore very quick to cost the distribution functions.** Moreover, Canalis's flexibility means you can invest in existing needs without adversely affecting future expansion.

## Practical to recycle

Over the last 20 years, recycling has become a major challenge for industry.

The composition of Canalis ranges **guarantees a 95% recycling rate.**

But the Canalis offers go one better... if a site is being restructured or enlarged, **the products can simply be removed and reinstalled in their new environment.**

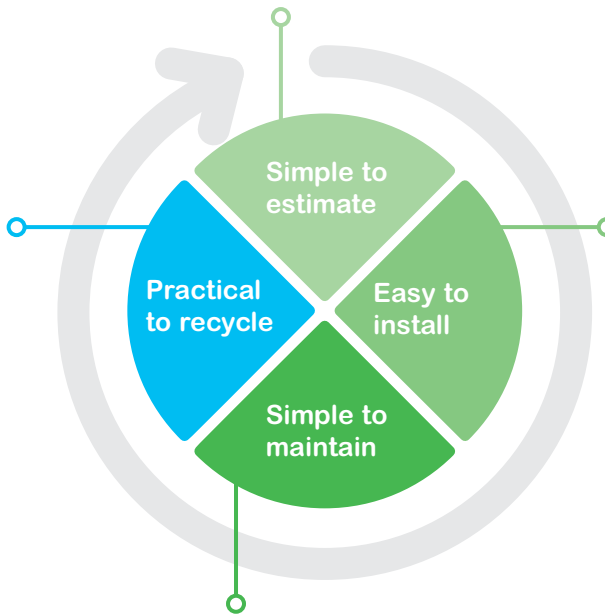

## Easy to install

**The compact nature of Canalis makes it easy to integrate in all parts of the building.**

Since it is based on a decentralized architecture, Canalis can be installed at the same time as the building is being built, which optimizes site construction schedules.

Because of the delayed differentiation linked to the Canalis architecture, new constraints can be taken into account without adding to the installation time.

### Controlling costs

The Canalis ranges are factory-tested, which ensures a very high level of quality on site and considerably improves the success of site acceptance tests.

## Simple to maintain

• **No maintenance is required on the Canalis electrical contacts.**

• The clarity of the Canalis architecture simplifies building maintenance and upgrades:  
> enlarging office space,  
> adding check-outs in a supermarket...

**Decentralized distribution ensures continuity of service;** when associated with a 100% maintained or non-maintained supply, the essential functions are guaranteed:

> maintaining the cold chain in a hypermarket,  
> lighting system in a car park...

- A
- B
- C
- D
- E
- F
- G

## Introduction

# Canalis, in total harmony with the environment

## Safety of life and property

A

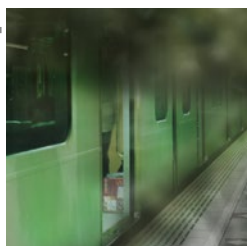

### With Canalis, no toxic emission in case of fire

The busbar trunking has a low combustible load. Its construction uses very little consumable material and is halogen free. In the event of a fire, the busbar trunking does not emit any gas or toxic smoke.

The busbar trunking helps prevent the propagation of a fire through partition walls and floors.

#### Halogen-sensitive applications

- Public buildings (infrastructures, hospitals, schools, etc.).
- Buildings with evacuation difficulties (high-rises, ships, etc.) and service-activity buildings.
- Sensitive processes (production of electronic components, etc.).

### Canalis contains no PVCs

When PVCs burn, they produce large amounts of smoke that can be a serious safety hazard.

#### • Reduced visibility:

- > risk of panic
- > complicates rescue work.

#### • Smoke toxicity:

- > hydrogen chloride gas (highly toxic)
- > carbon monoxide (danger of asphyxiation).

#### Example:

Consequences of a fire in a 100 m<sup>2</sup> office with electrical distribution by cables.

200 kg of cables (i.e. 20 kg of PVC) produces:

- 4400 m<sup>3</sup> of smoke.
- 7.5 m<sup>3</sup> of hydrochloric acid.
- 3.7 kg of corroded steel.

B

C

D

E

F

## Health

G

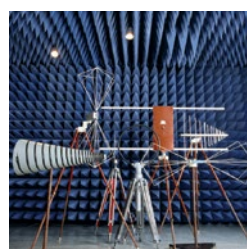

### Canalis reduces the risk of exposure to electromagnetic fields

According to the WHO (World Health Organisation), exposure to electromagnetic fields can be a health hazard starting at levels as low as 0.2 micro-Teslas and could represent a long-term risk of cancer. Some countries have created standards that stipulate limits (e.g. 0.2  $\mu$ T at 1 metre in Sweden).

All electrical conductors generate magnetic fields proportional to the distance between them. The design of Canalis busbar trunking with tightly

spaced conductors in a metal enclosure helps to considerably reduce radiated electromagnetic fields.

The electromagnetic field characteristics of Canalis busbar trunking are well-defined and measurements show that they are far below potentially dangerous levels.

You will find the magnetic induction values of our products on the "Characteristics" pages.

# Canalis, in total harmony with the environment

## Environment



### Canalis is fully recyclable

- Canalis busbar trunking can be reused. Canalis busbar trunking is designed for a long service life and can easily be dismantled, cleaned and reused.
- All packaging materials can be recycled (cardboard or recyclable polyethylene film).
- All Canalis products are designed for safe end-of-life recycling. PVC, on the other hand, requires neutralisation of the hydrochloric acid produced using lime and generates dioxins that are extremely toxic.

**Example:**

1 kg of PVC generates 1 kg of waste.



### Canalis helps conserve natural resources

- The depletion of raw materials (copper, plastics, etc.) is one of our ongoing concerns. For this reason, we have optimised the used of all materials used to make our busbar trunking.
- Reduction of dangerous or polluting materials. We design our products to meet future European directives.
  - Reduction in the weight of insulating materials.
  - Reduction in the use of plastics for improved fire performance: less energy released during combustion, thereby limiting propagation and facilitating extinction (lower calorific value).

## Conservation of natural resources



### Canalis reduces your line losses by 20 %

### Canalis divides your consumption of plastic by a factor of four

The cost of an electrical installation includes the initial investment for the equipment and its installation, the cost of maintenance and the cost of energy losses during operation.

The concept of decentralised distribution is a way to merge all the circuits in one and thus to reduce to the maximum the low cross-section lengths and the weight of insulating materials.

**Example:**

34 m of Canalis KS 250 A trunking equipped with fourteen 4-pole 25 A feeders.

Type of distribution	Insulation	Consumption
<b>DECENTRALISED</b> 	<p>23 kg</p>	<p>1600 Joules</p>
<b>CENTRALISED</b> 	<p>90 kg</p>	<p>2000 Joules</p>

$K_S$ : diversity coefficient = 0.6



# Introduction Canalis®

A

From the transport to the distribution...

Canalis is the core of your installation

B

C

D

E

F

G

DB41145

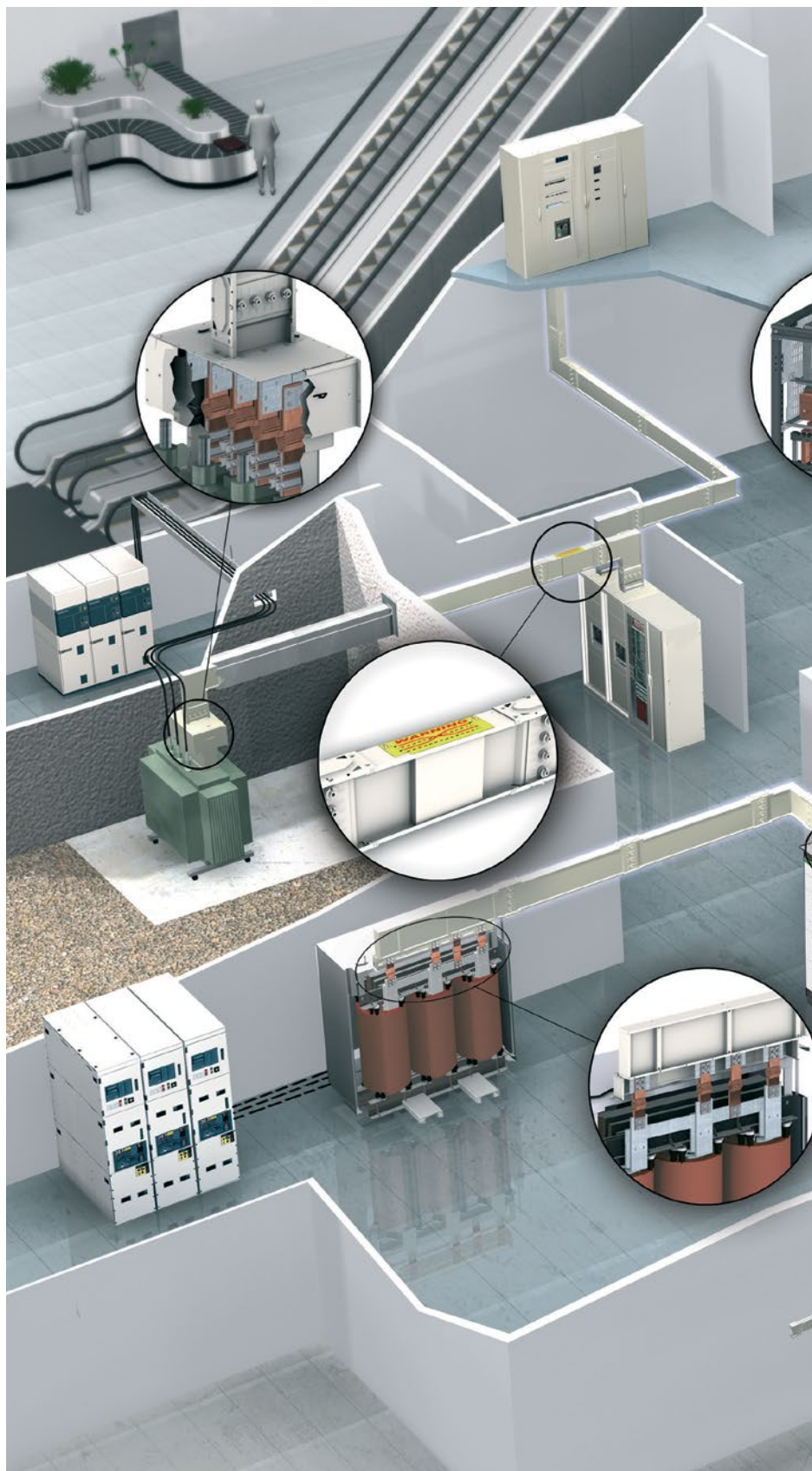

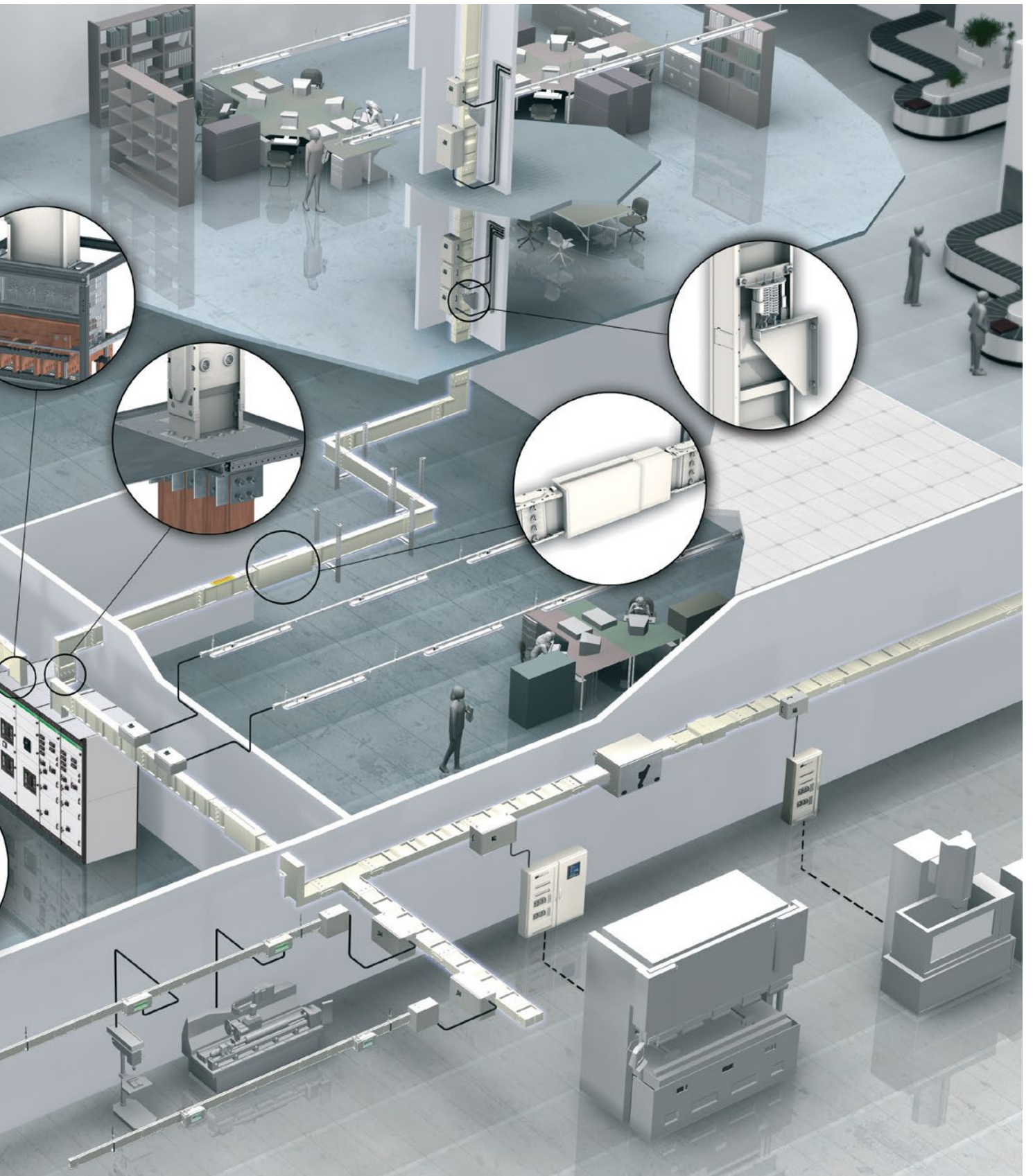

- A
- B
- C
- D
- E
- F
- G

## Introduction

# Canalis KT, a display of advantages

## A compact solution

A



- The compact size of Canalis KT means it takes up very little space in the building:
  - > used as a rising main, it takes up only a minimum of space
  - > used for horizontal distribution, it fits easily into the building's structure (false floors, false ceilings, service shafts, etc).
- Changes in direction have been designed to optimise the space taken up, contrary to an equivalent installation using cables which requires large bending radii.
- Tap-off units, complete with protective devices, are fitted along the entire length of the busbar trunking thus reducing the floor area taken up by the electrical distribution switchboards.

B

C

D

## A simple and economical system



- The design study is easy to perform as it does not require a detailed layout of each load. Equipment choice is pre-determined and optimised.
- Installing the busbar trunking requires 2 or 3 people only, for a time equivalent to that for installing cableways. The time normally needed for laying cables is therefore saved.
- Connection to the MV/LV substation is made using a quick fitting joint block. The tap-off units can be prepared in the workshop thus reducing on-site time. Their connection to the busbar trunking is done in a single plugging-on operation.
- Installing busbar trunking lengths can be done as and when building work progresses, thus optimising on-site work and allowing possible unexpected events to be anticipated in advance.
- It is also important to note that busbar trunking is a factory tested solution, meaning the time needed for inspecting connections is reduced (visual inspection of tightening torque).

E

F

G

## Operating continuity

When working on the electrical installation, the busbar trunking provides immediate readability of the electrical circuit thus allowing the appropriate zone to be quickly identified.

**Tap-off units can be plugged-on and off without the need for a shutdown; service continuity is thus irreproachable.**

# Canalis KT, a display of advantages

## Certified installation



- Busbar trunking temperature rise and short-circuit withstand are known and independent of the installation. Coordination of the Schneider Electric system results in complete control of the electrical network.
  - **Installation standards UTE C 15-105 chapter B.6.2 and IEC 60364 chapter 5.523.6 stipulate that above 4 parallel cables, it is preferable to use busbar trunking.** Paralleling many cables leads to uneven distribution of currents and the risk of abnormal temperature rise.
  - **Seismic certification to IEC 60980, Richter scale >7 and MSK 64 severity 9.**
  - The busbar trunking and tap-off units **are designed to guarantee the safety of personnel and equipment:**
    - > plug-on connections to silver-plated copper bars
    - > bolted connections with tightening torque guaranteed by torque nuts
    - > foolproof system to avoid the risk of assembly errors
    - > IP55 certified splash and dust protection
    - > **sprinkler** resistance test in compliance with Volkswagen specifications (valid only for top-mounted units)
    - > access to live parts have IPxxD protection (1 mm wire diameter).
- Its metal enclosure and high protection degree protect the busbar trunking from all external aggressions (corrosion, rodents, etc).

## A large range of tap-off units

Canalis KS tap-off units are fully compatible with Canalis KT:

- They cover all your requirements:
  - > Canalis KS tap-off units: 63 to 630 A
  - > Canalis KT tap-off units: 400 to 1250 A.
- They offer circuit breaker or fuse protection.

This offer includes tap-off units that can be fitted with the Transparent Ready system:

- They monitor your installation to avoid overloads, thus ensuring service continuity
- They provide metering to allow accurate management of your electrical distribution network (allocation of costs to each consumer).



A

B

C

D

E

F

G

# Introduction

## Canalis is adapted for all types of buildings

### Key points

A

#### Office and hospital buildings

- Fire barrier
- Halogen free
- Small size
- Operating continuity

B

#### Car industry and industrial buildings

- Operating continuity
- Able to be evolved
- Low voltage drops
- Network readability

C

#### Shopping centres, airports and exhibition centres

- Halogen free
- Distribution and metering
- Able to be evolved
- Sprinklers

D

#### Internet Data Centers

- Operating continuity
- High tap-off density
- Able to be evolved
- Network compactness and readability

E

F

G

Gaflly/Imagoe-52478040-300



Imagoe4-300



100144-300



CLIP027569-300



CLP0300696\_RGB\_EA-300

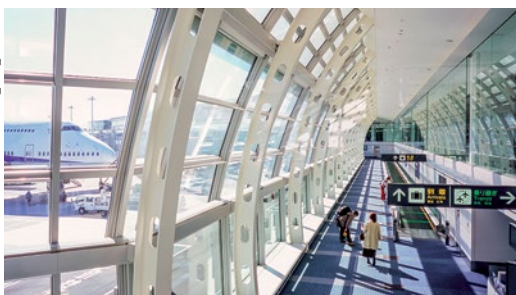

PP396077-68\_L



# Introduction Canalis® Solutions



## Solution for Data Center

- iBusway for Data Center catalogue: **DEBU028EN**
- iBusway for Data Center brochure: **DEBU027EN**

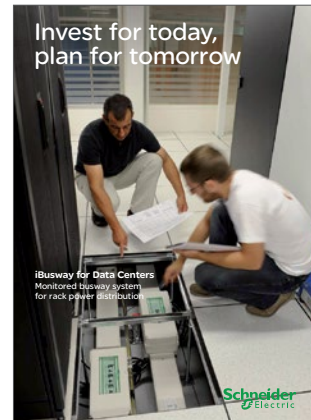
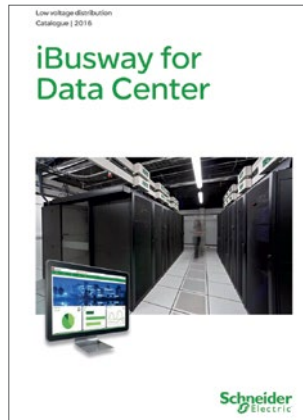

## Solution for lighting management

- iBusway for lighting management: Canalis DALI technical installation guide **DEBU032EN**
- Brochure iBusway for lighting management: **DESWED112002EN**
- Catalogue iBusway for lighting management: **DEBU035EN**

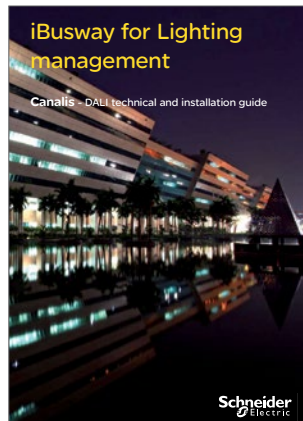

## Application datasheets/Guide

- In cruise ships: **DESWED105014EN**
- In livestock production buildings: **DESWED105010EN**
- In logistic centers: **DESWED105011EN**
- In car parks: **DESWED108011EN**
- In greenhouses: **DESWED105013EN**
- In garages: **DESWED106004EN**
- In hypermarkets: **KD0C98CTAHYEN**
- In automotive industry: **KD0C98CTAAUEN**
- In Photo-Voltaic:  
**For information consult your sales office**



## Design guideline

### Usage of Canalis KT in PV applications



## Introduction

## Canalis, the reference all around the world

## Tertiary

Applications	Name	Lighting and low current		Medium current		High current	Country
		KBA	KBB	KN	KS	KT	
Offices							
	Air France (headquarters)				●		France
	Allianz				●	●	Germany
	Axa	●			●		France
	Chamber of Commerce					●	Luxembourg
	Commerz Bank		●		●		Germany
	Lexel			●	●		Sweden
	Telefónica					●	Spain
	Trade Center	●				●	Spain
	Tour du RDC				●	●	Tunisia
	Turning Torso				●		Sweden
	Vodafone			●			New Zealand
Internet Data Center							
	Banco Commercial Português				●	●	Portugal
	Colt			●		●	France
	Digiplex			●	●		Sweden
	IBM	●		●	●	●	Spain, Italy
	MCI-Worldcom	●		●	●	●	Italy, United Kingdom
Hotels and restaurants							
	Hyatt					●	Tunisia
	Mc Donald's						France
	Soldeo Andorra Hotel				●	●	Spain
Hospitals							
	Children Clinic				●	●	Sweden
	Brussels University Hospital						Belgium
	Derby Hospital				●		United Kingdom
	Oran Hospital			●		●	Algeria
	St Joseph Hospital				●		France
	Stockholm Hospital				●		Sweden
	Val de Grâce Hospital				●		France
	Michalon Hospital				●	●	France
	Manussia Hospital				●		Egypt
Supermarkets and hypermarkets							
	Alcampo	●		●		●	Spain
	Auchan	●	●	●	●	●	World
	B&Q		●	●	●		United Kingdom
	Carrefour	●	●	●	●	●	World
	Coop	●		●	●		Italy
	Fnac	●				●	Spain, France
	Ikea	●		●	●	●	China, Spain, France, Sweden
	Mark & Spencer	●					Belgium, Spain, United Kingdom
	Toys'R Us				●		Spain

## Canalis, the reference all around the world

## Industry

Applications	Name	Lighting and low current		Medium current		High current	Country	
		KBA	KBB	KN	KS	KT		
Car industry								
	BMW	●	●	●	●		Italy	
	Citroën	●	●	●	●	●	China, Spain, France	
	Daewo				●		South Korea	
	Dacia	●	●	●	●	●	Romania	
	Iveco	●		●	●	●	Spain, Italy	
	Peugeot		●	●	●	●	China, Spain, France	
	Nissan	●	●	●	●	●	Spain	
	Renault	●	●	●	●	●	Spain, France, Czech Republic	
	Seat						Spain	
	Valéo	●			●	●	China, France, Italy, Poland	
	Volkswagen		●	●	●		Spain, Germany	
	Other industries							
	Aerospace industry							
	Airbus	●			●	●	Italy	
Food-processing industry								
	Coca-Cola	●				●	Spain, Italy, Belgium	
	Danone	●			●	●	World	
	Pasquier			●	●		France	
Livestock production farms and greenhouses								
	Favier henhouse	●					France	
	Greenhouse		●				Netherlands	
Ceramic industry								
	Esmalglas ceramic	●	●	●	●	●	Spain	
Electricity								
	Legrand	●					France, Turkey	
Watch-making								
	Rolex	●			●	●	Switzerland	
Microelectronics								
	Intel	●	●	●	●		Irelande	
	ST Micro-electronique	●		●	●	●	France	
Lead industry and water treatment								
	Grundfos				●		China	
Industrial technology								
	Bosch	●			●		China	
Telephony								
	Phillips				●		Netherlands	
	Nokia	●			●		Sweden	
Textile industry								
	Louis Vuitton	●		●	●		Spain	
	Delta	●		●			Israel	

A

B

C

D

E

F

G

## Introduction

## Canalis, the reference all around the world

## Infrastructure

Applications	Name	Lighting and low current		Medium current		High current	Country
		KBA	KBB	KN	KS	KT	
Airports							
	Paris Airport	●	●	●	●	●	France
	Cairo Airport				●		Egypt
	Heathrow Airport			●	●	●	United Kingdom
	Hong-Kong Airport					●	China
	Landvetter Airport				●		Sweden
	Arlanda	●			●	●	Sweden
	Satelite Barajas					●	Spain
Marine							
	Chantier de l'Atlantique				●	●	France
	Meyerwerft				●	●	Germany
Undergrounds							
	Guangzhou Underground	●					China
	London Underground		●				United Kingdom
	Madrid Underground	●				●	Spain
	Singapore Underground					●	Singapore
Other infrastructures							
	Alexandria Library				●	●	Egypt
	Centre international d'exposition de Suzhou	●			●		China
	CERN				●	●	Switzerland
	Stade de France				●	●	France

# Introduction Canalis tools and services

## Working together on your solution

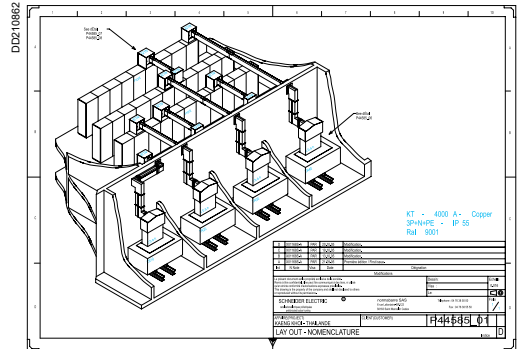

Our teams are available to provide customers with technical assistance throughout the installation of their projects.

### Design of electrical distribution architectures:

- design of decentralized transport and distribution systems
- technical and financial optimization of busbar trunking design projects
- transformer/switchboard link
- installation coordination and discrimination.

### Full installation drawings\*:

- 3D AutoCAD drawings with corresponding parts lists
- 2D drawing with dimensions
- detailed connection drawings.

\*All AutoCADs are available on Traceparts.com  
BIM Models: are available on se.com.

Site supervision and commissioning assistance.

Training for designers and contractors.

## Canalis Busway "Total Solution":

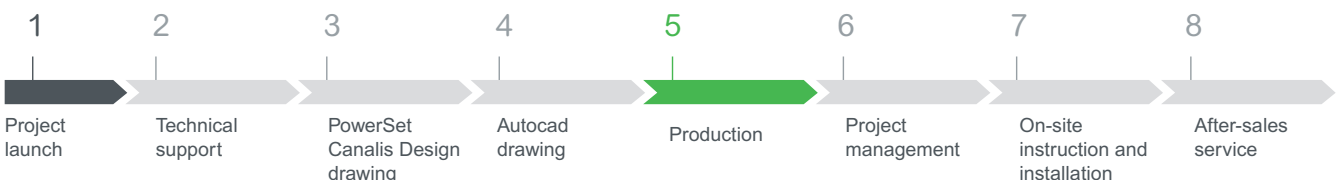

## Introduction

# Canalis tools and services

Empowering you with smart tools



Not only providing experts to support you in your project but also provide you with smart solutions and tools for fully controllable solution.

Through QR codes on packaging, product and JB labellings sticker; customer experience haven't been more easier:

### For Installers

- Easily check delivered products and dispatch it at it's future location for faster installation
- More agile access to product and installation instructions
- Easy and remote Installation tasks progression follow up through facility expert
- Can easily access all information needed for future extension.

### For Facility Manager

- Resilient management of future installation through easily accessing all product and project data
- Agile maintenance management through assigning tasks on facility experts for certain junctions using QR codes and labeling sticker on JB.

## Canalis Busway "Total Solution":

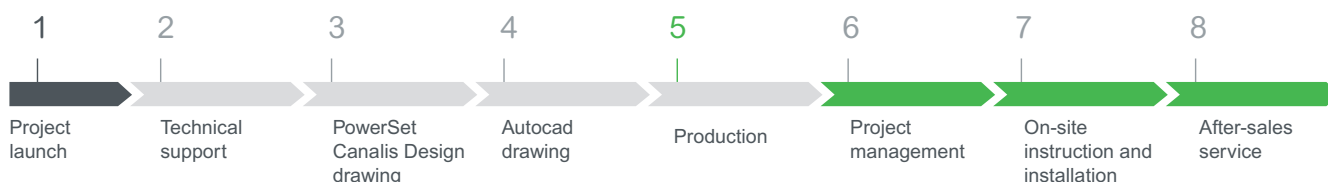

Label Sticker

**Label Sticker**



Description	Cat. no
KT JB Positioning Label Sticker	KTB0100YL1

Label stickers to be stick on joint blocks in site during installation. It ease maintenance management and maintenance people to detect JB position and assign tasks on facility expert (Optional Choice).

Example of label roll (Size: 15 mm x 25 mm)

DB410876

DB413395

Junction  
**1-2**

Junction  
**2-3**

Junction  
**3-4**

..... up to

Junction  
**99-100**

Label image

DB43354

**Canalis®**

**KTA2000LC4A**  
KT 4x2000AL EDGEWISE ELBOW  
СЕКЦИЯ УГЛОВАЯ ВЕРТИКАЛЬНАЯ

**3L+N+PE**  
In = 2000 A  
Ui = 1000 V ~

**IP55**

QR Code

**CE**  
RX-2015-04-14  
Made in Hungary  
Сделано в Венгрии

IEC 61439-6 | EN 61439-6 | **ERC** | **817642-220**

**L1 L2 L3 N PE**

**Schneider Electric**

- A
- B
- C
- D
- E
- F
- G

# Introduction Cantools

A

## Quotation and Design tools

B

C

D

E

F

G

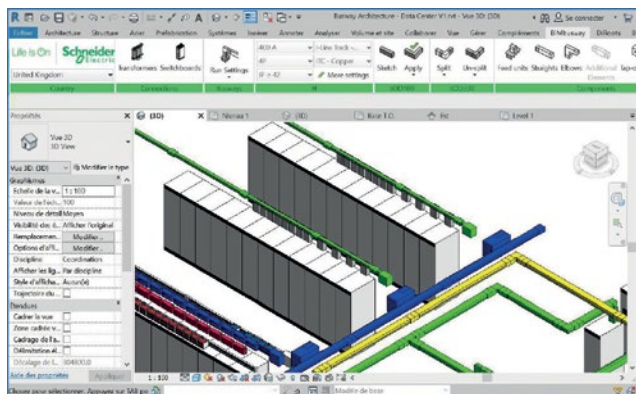

### CanBrass

> is a design and costing tool for Canalis busbar trunking runs.



### CanCad

> is a Plug-in for Autocad. It allows to easily design and get bill of materials.



### BIMBusway

> is a Plug-in for Revit. It allows to easily design and get bill of materials in BIM format.

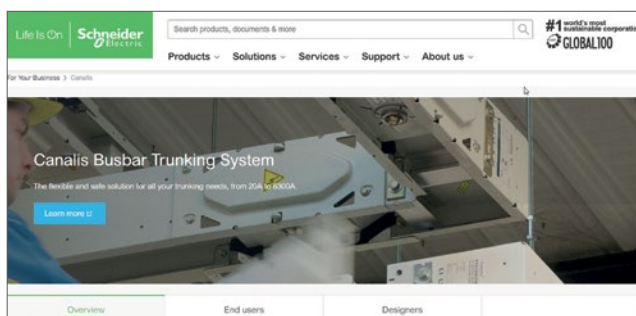

... about Canalis and I-Line ranges

# Presentation and description

Introduction	3
<b>Presentation</b>	<b>24</b>
<b>Panorama of Canalis range</b>	<b>24</b>
Lighting distribution and power distribution	24
<b>Canalis KTA from 800 to 5000 A</b>	<b>26</b>
For horizontal transport and distribution	26
For distribution to different levels	28
<b>Tap-off units from 25 to 1250 A</b>	<b>29</b>
<b>Description</b>	<b>30</b>
<b>General</b>	<b>30</b>
<b>Run sections</b>	<b>32</b>
<b>Other run sections</b>	
<b>Disconnectors and run protective devices</b>	<b>33</b>
<b>Change of direction sections</b>	<b>34</b>
<b>Connection sections</b>	<b>35</b>
<b>Connection accessories</b>	<b>40</b>
<b>Supports and fixings</b>	<b>42</b>
<b>Tap-off units</b>	<b>43</b>
<b>Plug-on tap-off units for circuit breakers</b>	<b>44</b>
<b>Plug-on tap-off units for fuses</b>	<b>45</b>
<b>Fixed tap-off units for circuit breakers</b>	<b>46</b>
Catalogue numbers and dimensions	47
Design guide	143
Installation guide	185
Recommendations	243
Index	248

# Panorama of Canalis range

## Lighting and power distribution

### Canalis KTA

A

B

C

D

E

F

G

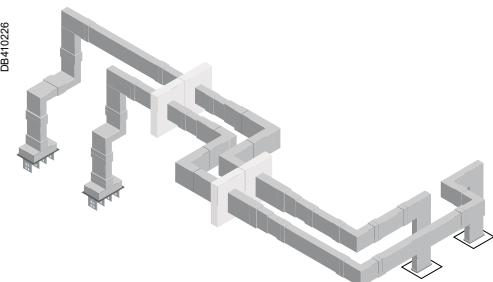
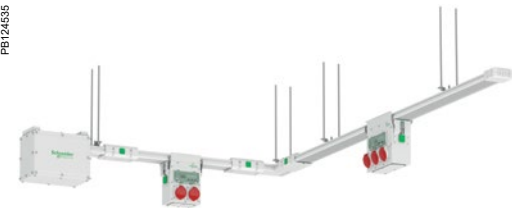
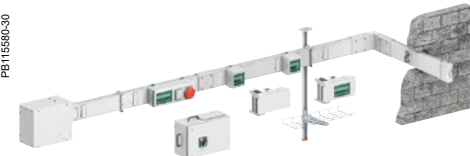

Rated service current	Rated insulation voltage	Color	Line components	
Inc	Ui		Length of components	Number of conductors

### Lighting and low power distribution from 25 to 40 A - IP55

Canalis KBA				
25 A	690 V	Pre-lacquered white (RAL9003)	2 m and 3 m	2 or 4 + PE
40 A				
Canalis KBB				
25 A	690 V	Pre-lacquered white (RAL9003)	2 m and 3 m	Single circuit 2 or 4 + PE Dual circuit 2 + 2 + PE 2 + 4 + PE 4 + 4 + PE
40 A				

### Power distribution from 40 to 160 A - IP55

Canalis KN *				
40 A	500 V	Pre-lacquered white (RAL9001)	2 m and 3 m	3L + N + PE
63 A				
100 A				
160 A				

\* Canalis KN range is available on se.com

### Horizontal and vertical distribution from 100 to 1000 A - IP55

Canalis KS *					
<b>Aluminium:</b> 100 A, 160 A, 250 A, 400 A, 500 A, 630 A, 800 A, 1000 A	<b>Copper:</b> 160 A, 250 A, 400 A, 630 A, 800 A	690 V	Pre-lacquered white (RAL9001)	3 m, 5 m and additional or customized components	3P + N + PE

\* Canalis KS range is available on se.com or catalogue: DEBU026EN

### Horizontal open track distribution from 250 to 630 A - IP42

I-Line Track				
250 A, 400 A, 630 A	690 V	Pre-lacquered white (RAL9003)	Standard 3 m or customized	3L + N + PE

### Power transmission and distribution from 800 to 6300 A - IP55

Canalis KT *					
<b>Aluminium:</b> 800 A, 1000 A, 1250 A, 1600 A, 2000 A, 2500 A, 3200 A, 4000 A, 5000 A	<b>Copper:</b> 1000 A, 1350 A, 1600 A, 2000 A, 2500 A, 3200 A, 4000 A, 5000 A, 6300 A	1000 V	Pre-lacquered white (RAL9001)	2 m and 4 m	3L + PE 3L + N + PE 3L + N + PER

\* Canalis KT range is available on se.com or catalogue: KTA: ref. DEBU021EN / KTC: ref. DEBU024EN

### Power transmission for outdoor and harsh environment from 800 to 6300 A - IP68

Canalis KR *				
800 A, 1000 A, 1250 A, 1350 A, 1600 A, 2000 A, 2500 A, 3200 A, 4000 A, 5000 A, 6300 A	1000 V	Gray (RAL7030)	Up to 3 m	3L 3L + N or 3L + PE or 3L + PEN 3L + N + PE

\* Canalis KR range is available on se.com or catalogue ref. DEBU031EN

# Panorama of Canalis range

## Lighting and power distribution

Branching points			Accessories	
Center to center distance		Protection type		
0.5 m, 1 m on 1 side	L + N + PE or 3L + N + PE (10/16 A) pre-cabled or to be cabled, with phase selection or fixed polarity, with lighting control	With fuses or without protection	> Flexible components > Fixing devices with quick adjustment > Communication bus (DALI, KNX, ASI) > Cable ducts	
0.5 m or 1 m on 1 or 2 sides	L + N + PE or 3L + N + PE (10/16 A) pre-cabled or to be cabled, with phase selection or fixed polarity, with lighting control	With fuses or without protection	> Flexible components > Fixing devices with quick adjustment > Communication bus (DALI, KNX, ASI) > Cable ducts	
0.5 m, 1 m on 1 side	16 A to 63 A (plug-in)	Units for modular circuit breakers, fuses and sockets	> Flexible components > Fixing devices with quick adjustment > Remote control bus > Cable ducts > Installation accessories	
0.5 m or 1 m on each side for horizontal version, and on one side for vertical version	16 A to 400 A (plug-in)	Units for circuit breakers (modular, Compact NSX), fuses, sockets	> Riser ducting offer > Fixing devices with quick adjustment > Cable ducts > Installation accessories > Fire barriers	
Continuous opened channel	16 A to 63 A outputs in tap-off units		> Data Center IT room > Fixing devices with quick adjustment > Installation accessories > Color customization	
0.5 m or 1 m	80 A to 630 A (plug-in) 400 A to 1250 A (bolt-on)	Units for circuit breakers (modular, Compact NSX), fuses, sockets	> Power supply ends > Direction change angles and T-pieces > Fixing devices and fuses	
-	-	-	> Power supply ends > Direction change angles and T-pieces > Fixing devices > Fire resistant elements	

A

B

C

D

E

F

G

# Presentation

## Canalis KTA from 800 to 5000 A For horizontal transport and distribution

### Canalis KTA

#### Run sections

- Rating: 800 to 5000 A.
- Transport sections:
  - fixed lengths: 2 and 4 meters
  - non-standard lengths: 0.5 and 3 meters
- Distribution sections:
  - fixed lengths: 2 and 4 meters.

PD202313\_r



#### Tap-off units

- Plug-in tap-off units:
  - protection by 25 to 630 A fuses
  - protection by 100 to 630 A Compact NSX circuit breakers.
- Fixed tap-off units:
  - protection by 400 to 1250 A Compact NS and NSX circuit breakers
  - protection by 400 to 1000 A fuses.

PD202314\_r2



#### Change-of-direction sections

- Change-of-direction sections adapt to all busbar trunking requirements.
- There are both fixed and made-to-measure lengths.

PD202315\_r

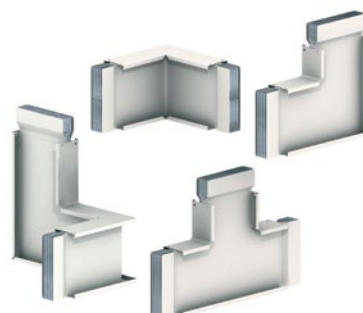

A

B

C

D

E

F

G

PB125376

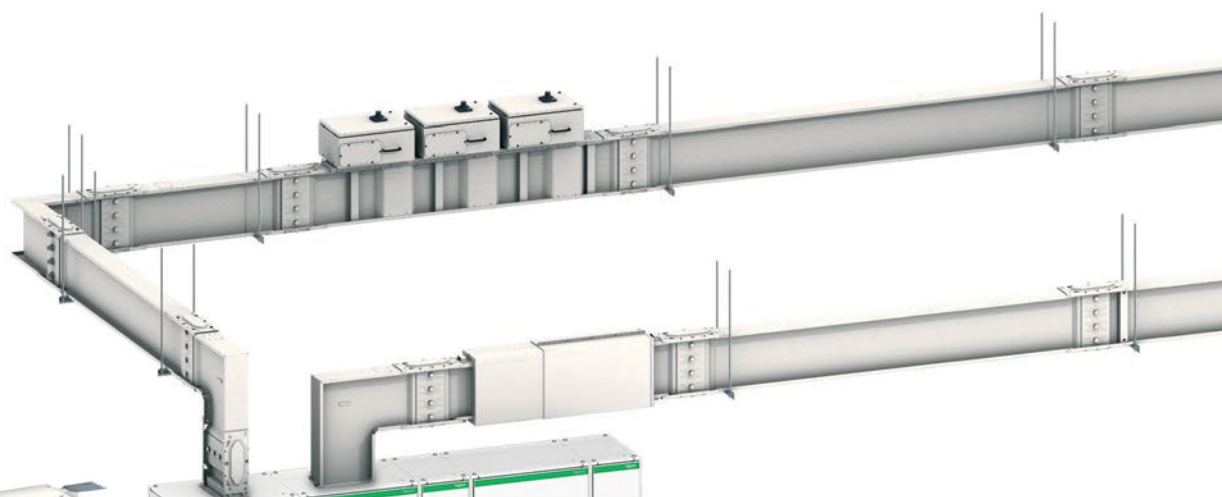

PD202328\_r



# Canalis KTA from 800 to 5000 A

For horizontal transport and distribution

## Interface connections

- Pre-fabricated interfaces connections can be incorporated into:
  - PrismaSeT and Okken switchboards
  - France Transfo dry-type transformers.

PD202431\_L

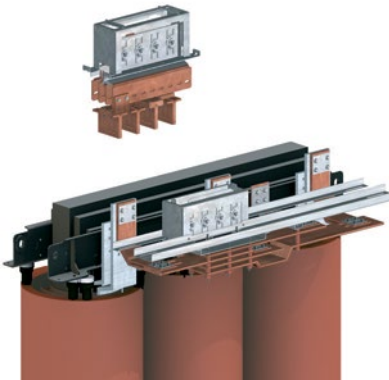

## Universal supply connections

- Supply connections allow the busbar trunking to be connected to the switchboard's busbar or to the transformer.

PD202217\_L

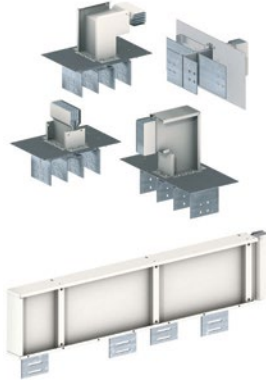

## Horizontal fixing supports

- There are two types of support for installing the busbar trunking horizontally.
- One type of fixing: to fix the busbar trunking to its support.

PD202218\_L

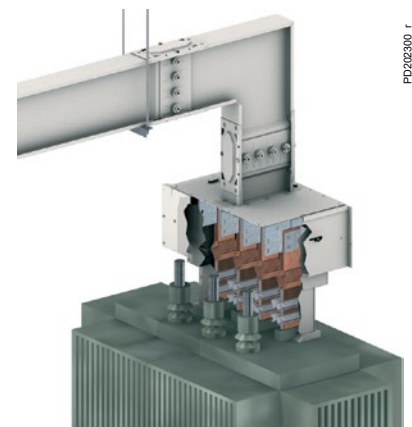
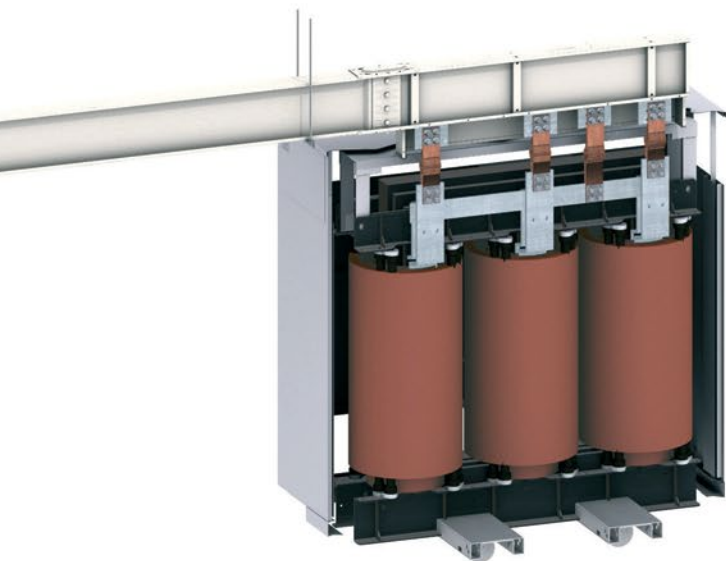
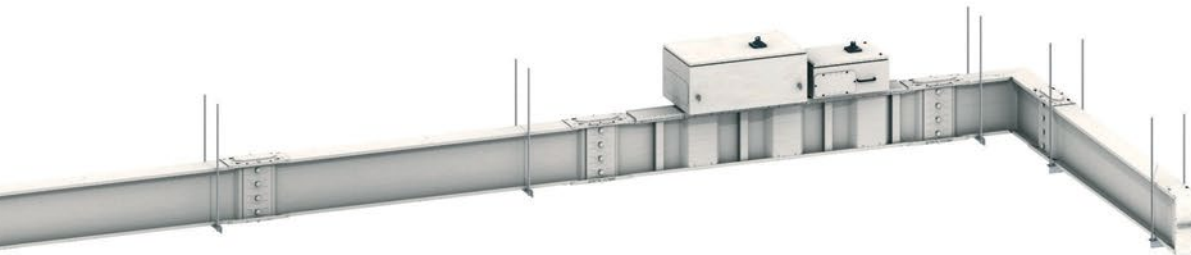
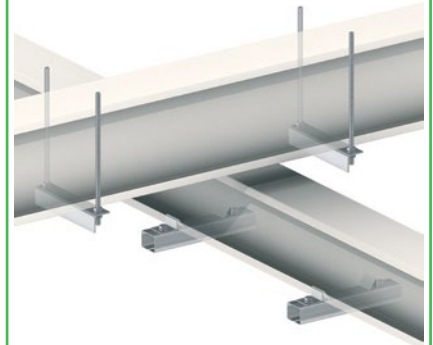

PD202300\_L



## Presentation

# Canalis KTA from 800 to 5000 A

For distribution to different levels

Rising mains

### Canalis KTA

#### Run sections

- Rating: 800 to 5000 A.
- Distribution sections, fixed or made to measure.
- Transport sections for going through floor slabs, made to measure 0.5 to 3 meter lengths.



#### Vertical fixing support

- For installing the busbar trunking vertically, they ensure:
  - height and depth adjustment
  - load sharing
  - absorption of expansions, vibrations, etc.
- They can be fixed either to the floor, the wall or to a bracket.

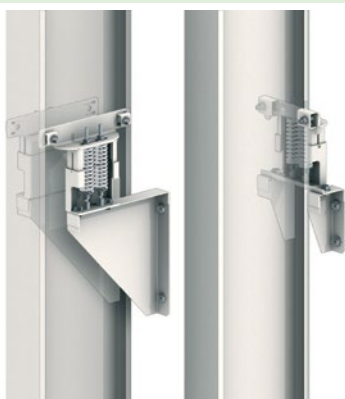





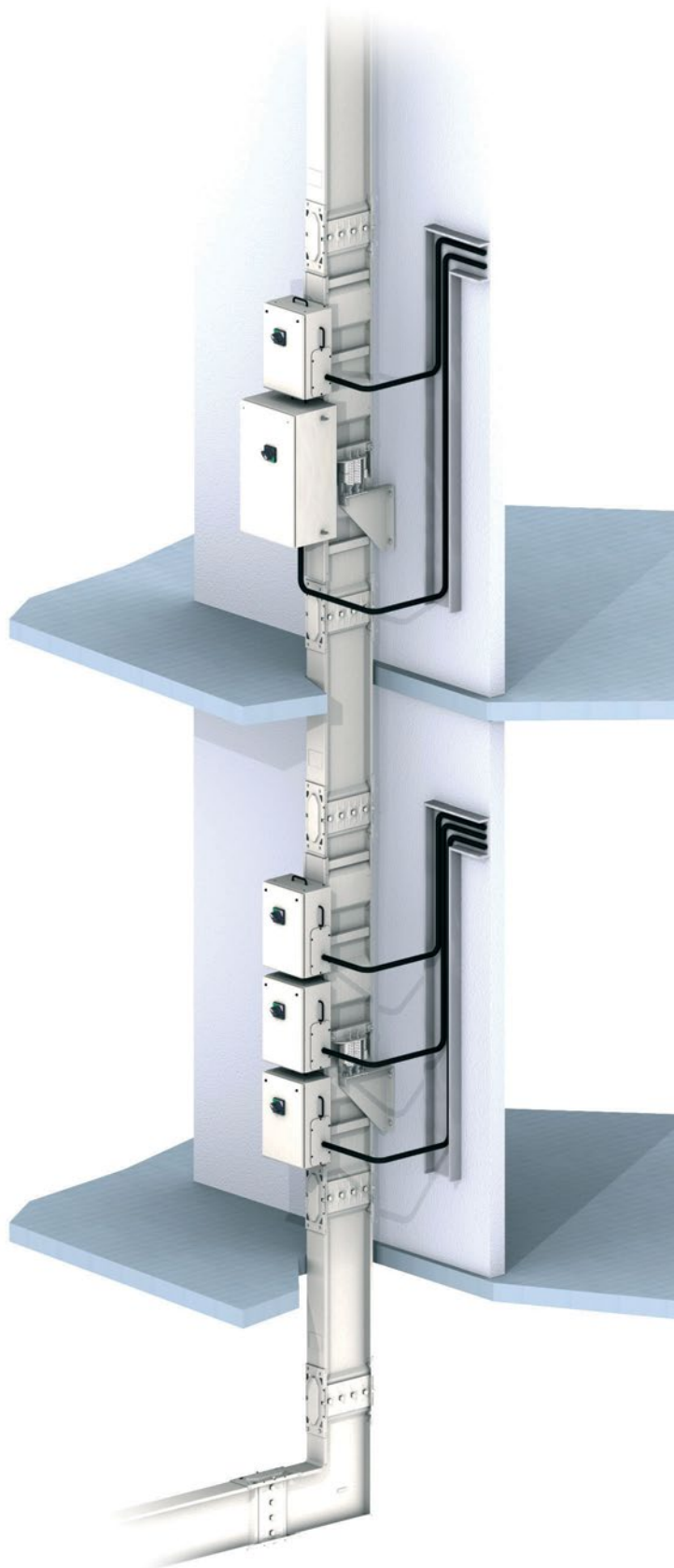













#### Tap-off units

- Plug-in tap-off units:
  - protection by 25 to 630 A fuses
  - protection by 100 to 630 A Compact NSX circuit breakers.
- Fixed tap-off units:
  - protection by 400 to 1250 A Compact NS and NSX circuit breakers
  - protection by 400 to 1000 A fuses.



# Presentation

## Tap-off units from 25 to 1250 A

Rating (A)	Type of protection			
	Modular switchgear	Compact NS and NSX	Fuses	Compact NSX with measurement and metering
<b>Plug-on tap-off units</b>				
25 to 100	 DE 406528 63 A, 8 x 18 mm modules	 PD202150_f For Compact NSX100 circuit breaker	 PD202138_f 25/50 A for NF/DIN fuses 32 A for BS fuses   PD202147_f 63 A for DIN fuses 100 A for NF/DIN fuses 80 A for BS fuses	
	 DB 406529 100 A, 12 x 18 mm modules			
160	 PD202150_f For NG125/160 circuit breaker	 PD202150_f For Compact NSX160 circuit breaker	 PD202233_f 160 A for NF/DIN/BS fuses	
250 to 400		 PD202324_f For Compact NSX250 circuit breaker	 PD202384_f 250/400 A for NF/DIN fuses	Fitted with DIN rail for Powerlogic PM810   PD202324_f For Compact NSX250 circuit breaker
		 PD202325_f For Compact NSX400 circuit breaker		 PD202325_f For Compact NSX400 circuit breaker
630		 PB124589 For Compact NSX630 circuit breaker	 PB124579 630 A for NF/DIN fuses	
<b>Fixed tap-off units</b>				
400 and 630		 PD202326_f For Compact NSX400 and NSX630 circuit breakers	 PD240004_f 400 to 630 A for DIN fuses <sup>(1)</sup>	
800, 1000 and 1250		 PD202327_f For Compact NS800, NS1000 and NS1250 <sup>(1)</sup> circuit breakers	 PD240005_f 800 to 1000 A for DIN fuses <sup>(1)</sup>	

(1) Tap-off units for NS1250 and fuses (from 400 to 1000 A) in IP31 only.



## Canalis KTA

The Canalis KT busbar trunking is intended for high power distribution and transport in industrial, commercial and tertiary buildings. Assembly of prefabricated sections that adapt to all run configurations.

### Run sections

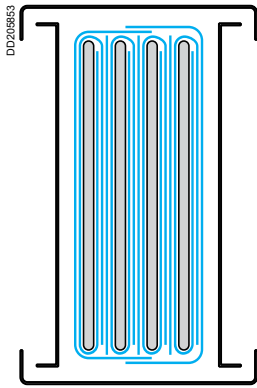

The conductors are sandwiched together inside the metal casing.

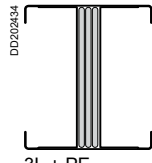
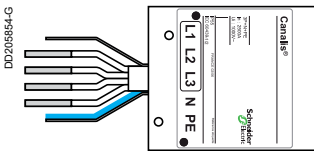

3L + PE

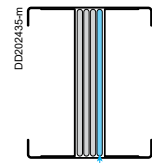

3L + N + PE

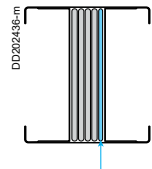

3L + N + PER

- 9 ratings are available, from 800 to 5000 A.
- 4 aluminium live conductors with identical cross-sections (3L + N + PE version).
- Conductors insulated using polyester film, class B 130°C, halogen free.
- Standard busbar trunking is IP55.
- Insulation voltage: 1000 Volts.
- Available polarities: 3L + PE, 3L + N + PE, 3L + N + PER (reinforced PE)

The KT busbar trunking is of compact design and can be installed edgewise, flat or vertically.

This design, allows the busbar trunking to be installed through a floor slab or fire barrier wall.

As standard, the Canalis KT busbar trunking acts as a fire barrier in accordance with IEC 61439-6.

The compact technology allows Canalis KT busbar trunking to withstand high short-circuit currents and is suitable for most electricity distribution applications.

The RAL 9001 pre-lacquered galvanized steel casing provides protection and mechanical fixing of the conductors.

Further, it is used as the PE protective conductor (in accordance with NFC 15100 and IEC 60364).

In its reinforced version 3L + N + PER, the busbar trunking is fitted with an additional internal conductor with a cross-section equal to half that of the phase conductor.

A reinforced version can be supplied on demand. This version has lateral reinforcement (see page "Characteristics").

The Canalis KT busbar trunking is suitable for applications containing harmonics by taking into account the appropriate derating factor. See "Harmonic currents" in the Design guide.

### Tap-off contact

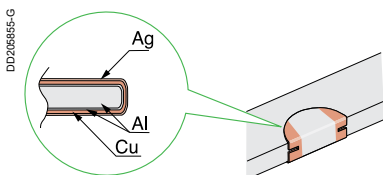

The electrical contact pads of the sections are made from bonded bimetallic aluminium/copper.

The KS plug-on tap-off units are connected to the busbar trunking whilst live (off-load) via spring jaw connections.

Contact zone coating:

- silver-plated copper at jaw contact points
- aluminium / silver-plated copper bimetallic saddle welded to the live conductors.

### Fire rated components

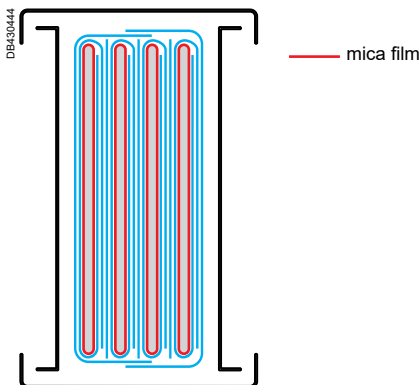

FT, FC and FP components are suitable for applications requiring continuity of service in case of fire. These components have the same cross section as the standard Canalis KT ones and are fully compatible and connectable.

These components comply with IEC 60331-1 and IEC 60331-21 for a duration of 480 minutes at 830°C.

To achieve this performance, the conductors are wrapped in a mica film before being isolated by a polyester film. The plastic parts of the joint blocks are also reinforced to withstand higher temperatures.

A

B

C

D

E

F

G

Joint block

DD205856-G

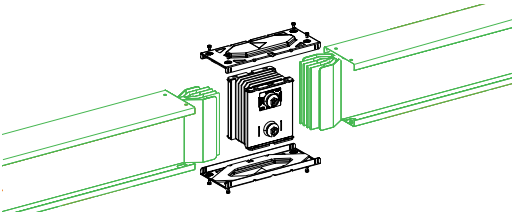

DD205857-G

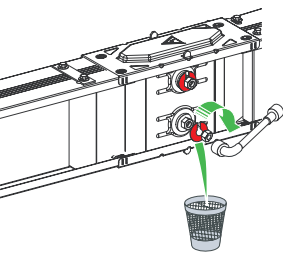

The junction between sections is made using a joint block.

The joint block provides the following:

- electrical junction between live conductors and between PE protective conductors, mechanical link between the two sections.

It provides simultaneous continuity between all conductors.

It is tightened using torque bolt(s) (1 to 4 depending on the rating) with snap-off heads.

The nut head snaps-off, freeing a red washer, when the correct tightening torque is reached.

This operation is checked visually:

- if the red washer is absent: it has been tightened
- if the red washer is visible: it has not been tightened.

This device guarantees the necessary contact pressure between live conductors and is operator independent.

For dismantling or maintenance operations, the nut has a second head. The tightening torque is 6 daN.m.

**All sections (apart from ER and EL feed units) are supplied with their joint block, delivered in a separate parcel.**

**If the run has a feed unit (ER or EL) at each end, an additional joint block must be ordered.**

Phase order

The standard phase order for the busbar trunking is denoted **N321**.

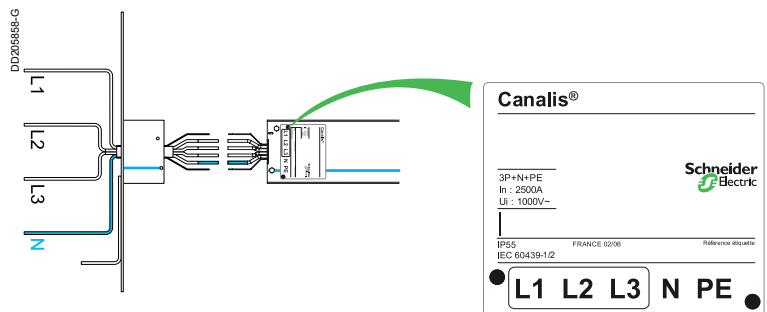

However, this order can be changed to **N123**. A label showing the phase order "N123" is supplied with each element to indicate the change.

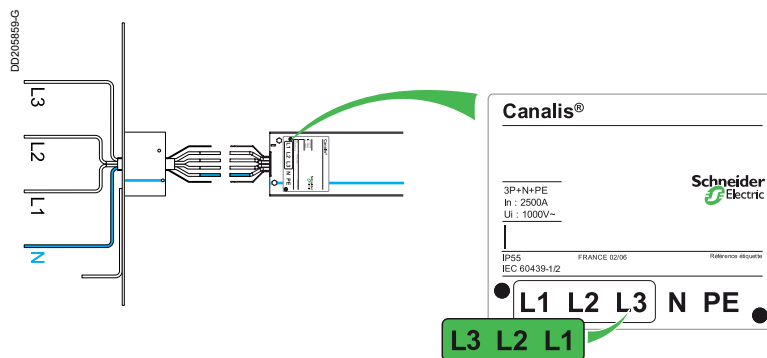

### Canalis KTA

#### Straight sections

A

B

C

D

E

F

G

#### Transport sections - Type ET

Transport the current without tap-off points.

Available in 2 and 4 metre fixed lengths or made to measure from 0.50 to 4 metres.

DD202390

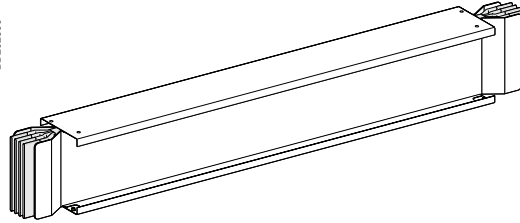

#### Sections with tap-off points for plug-on tap-off units - Type ED

ED run sections are for current distribution.

They use 25 to 630 A KS tap-off units.

These tap-off units can be plugged-on whilst live, but off-load.

Available in fixed 2 and 4 metre lengths with 3 tap-off points on one side or made to measure from 2.5 to 3.5 metre.

DD205660

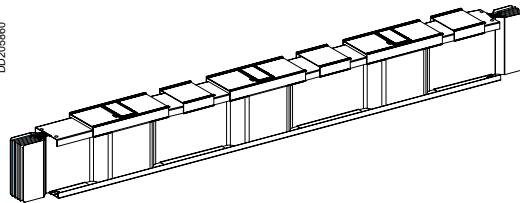

#### Sections with tap-off points for fixed tap-off units - Type EB

EB run sections are for current distribution.

They use specific KT 400 to 1250 A tap-off units.

These tap-off units can only be fitted / removed when the run is not energised.

Available in a 2 metre fixed length with one tap-off point or a 4 metre fixed length with 2 tap-off points.

DD205961

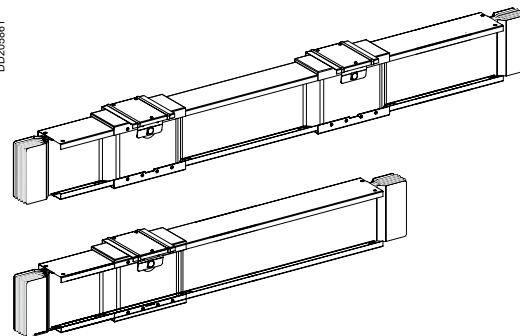

# Other run sections

## Disconnectors and run protective devices

### Other run sections

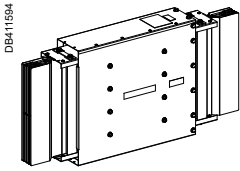

#### Expansion section - Type DB

It controls and absorbs the expansion of Canalis runs and must be used on runs over 30 metres and each time the busbar trunking passes through a building expansion joint. Refer to the installation guide.

Available in a 1 metre length, it can be fitted vertically or horizontally. At its centre it has flexible conductor joints and a sliding case able to absorb the relative movements of each part of the section.

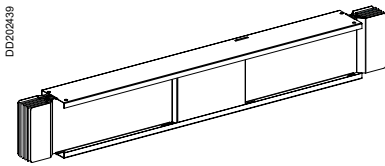

#### Transposition sections - Types TN, TP

Used when the phase order of the switchboard is different to that of the transformer.

Available in a 1 metre length and is the same physical size as a transport section.

- The TN version transposes the neutral.



- The TP type transposes the phases.

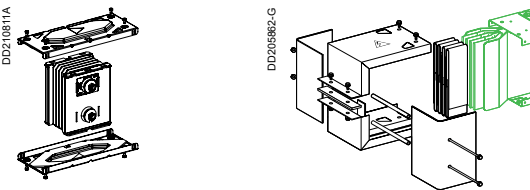

#### Additional joint block - Type YA

If the run has a feed unit (supplied without a joint block) at each end, an additional joint block must be ordered.

Each joint block is supplied with the necessary covers, nuts and bolts.

#### Run end cover - Type FA

The end cover protects and insulates the conductor ends and is fitted to the last section.

### Disconnectors and run protective devices

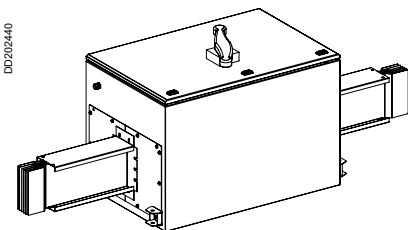

Fitted between 2 flat or edgewise sections, they isolate or protect a busbar trunking part run.

Each assembly is supplied fitted with a 3 or 4-pole device complete with rotary handle.

Supplied with:

- Pre-Wired Auxiliary with connection terminal kit
- lifting rings
- upstream and downstream terminal shields.

Colour: white RAL 9001, 100 % polyester paint on galvanized sheet steel.

Refer to manufacturer's data for switchgear characteristics.

Fitted with a rotary handle, the tap-off unit can only be opened once the device has been switched off.

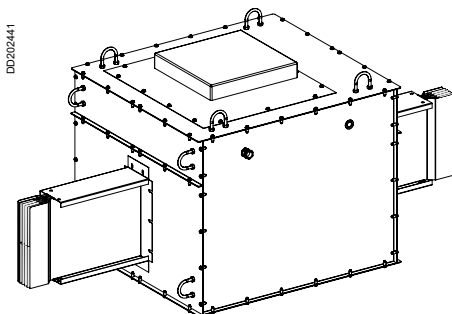

#### Run disconnector tap-off units - Type SL

Type SL for:

- **Compact NS1000 to 1600 A** type NA fixed isolators:
  - unhingeable door
  - 3-point closing (possibility of locking with key lock, not supplied)
- **Interpact INV** isolator, **2000 to 2500 A**:
  - unhingeable door
  - 3-point closing (possibility of locking with key lock, not supplied)
- **Masterpact NW3200 A** type HA fixed isolator supplied with:
  - transparent protection cover
  - adaptation kit for Ronis lock + 1 Ronis lock
  - complete Harting plug, not cabled.

#### Run protection tap-off units - Type PL

Type PL for:

- **Compact NS1000 to 1600 A** type N fixed circuit-breakers:
  - unhingeable door
  - 3-point closing (possibility of locking with key lock, not supplied).

For circuit-breakers greater than 1600 A, consult the sales office.

# Description

## Change of direction sections

### Canalis KTA

#### Simple changes of direction

A

B

C

D

E

F

G

#### Elbows - Types LP and LC

To go up or down, to turn right or left:

- type LP, flat elbow available in fixed or made-to-measure lengths

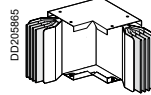

- type LP●C, flat made-to-measure angled elbow

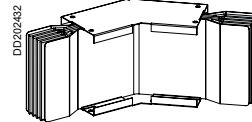

- type LC, edgewise elbow available in fixed or made-to-measure lengths

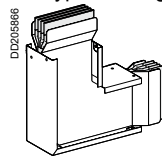

- type LC●C, edgewise made-to-measure angled elbow.

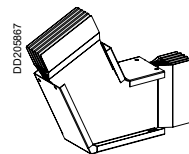

#### Edgewise T junctions - Type TC

To feed runs perpendicular to the main run.

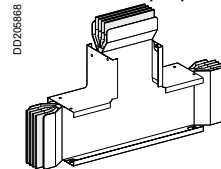

#### Changes of direction

#### Zeds - Types ZP, ZC and CP

3-branch made-to-measure:

- flat or edgewise, to move the run axis upwards, downwards, to the right or to the left without having to bend the busbar trunking:

- type ZP, flat Zed

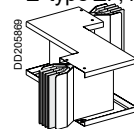

- type ZC, edgewise Zed

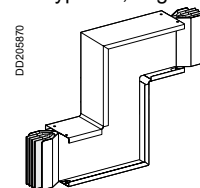

- edgewise / flat, to provide the busbar trunking with a bend:

- Type CP, edgewise and/or flat Zed.

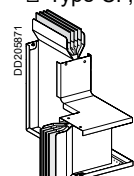

To connect the KTA busbar trunking to different terminals or to transformer, switchboard, generator set, etc. busbars. Canalis offers high performance connection sections which meet all requirements.

These sections provide installation flexibility combined with quick and simple assembly.

Further, the connections are made using torque bolts which provide both ease of installation (use of a standard spanner for tightening to 60 N.m) and a visual check before energising.



### Connections via interface to PrismaSeT, Okken and Trihal

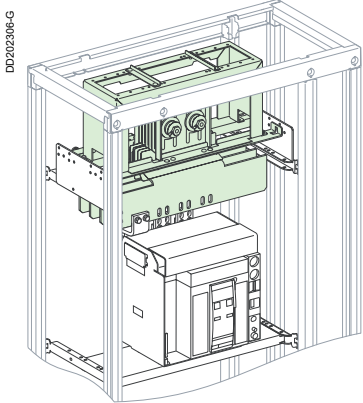

PrismaSeT switchboard.

Direct connection to Trihal transformers and PrismaSeT & Okken switchboards. Supplied factory or panelbuilder assembled and tested to IEC 61439-1 and IEC 61439-6.

Quick and simple connection of the busbar trunking to the interface. Reduced size.

Joint block integrated into the interface. A sealing kit (rating dependent) must be ordered.

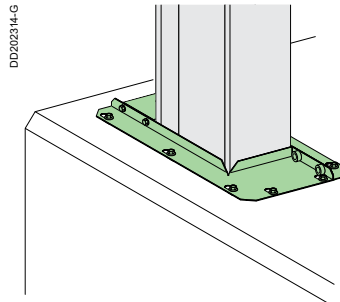

Sealing kit

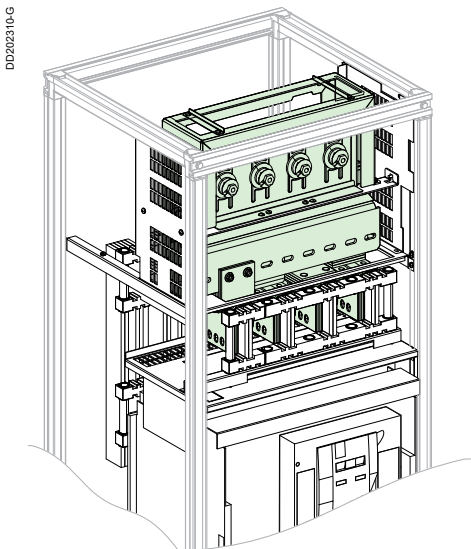

Okken switchboard.

#### PrismaSeT and Okken switchboards

For fixed or draw-out incoming device, front or rear connection:

- Masterpact NW08 to NW50 or NT06 to NT16 circuit-breaker
- Compact NS630b to NS1600 circuit-breaker.

Possibility of switching the phases around.

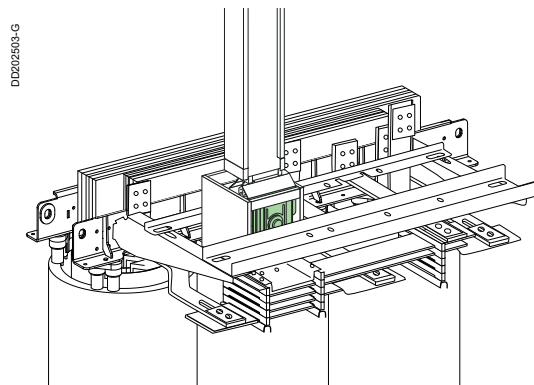

#### France Transfo Trihal dry type transformers

For naturally ventilated or force ventilated transformers.

Protection degree:

- IP00
- IP31.

Secondary voltage: 410 V.

±15 mm adjustment in the 3 axes.

### Canalis KTA

#### Universal connections to switchboards and oil immersed transformers

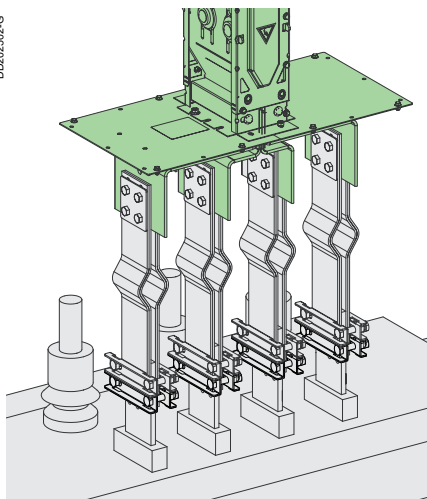
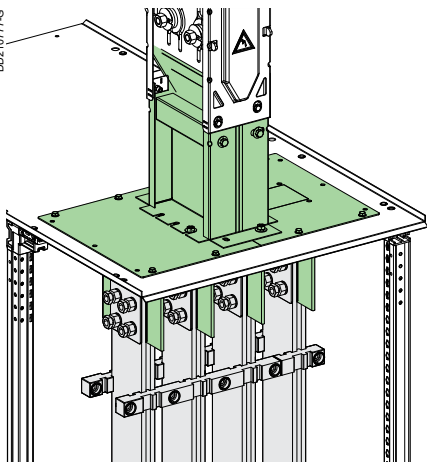

#### Feed units - Type ER

They allow the busbar trunking to be connected to a switchboard's busbar, or to the terminals of an oil immersed transformer, generator set, etc.

They come complete with a mounting plate fitted:

- either directly to the roof of the switchboard
- or via the intermediary of a protective cover.

Vertical or horizontal incoming busbar trunking.

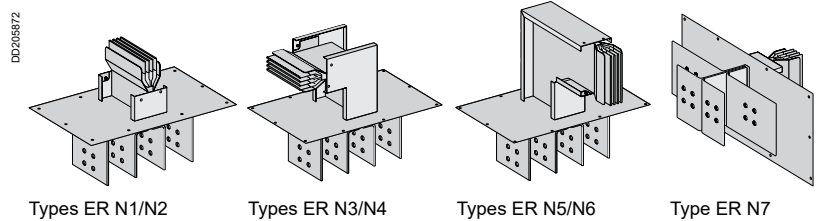

Connection:

- either directly to the busbar
- or by flexible bars and connection plates
- or by braids
- or by cables.

- ER feed units are supplied without a joint block.
- If the run has a feed unit at each end, an additional joint block must be ordered.
- ER N1 to N6 customer connections are tin plated aluminium.
- ER N7 Customer connections are bare copper.

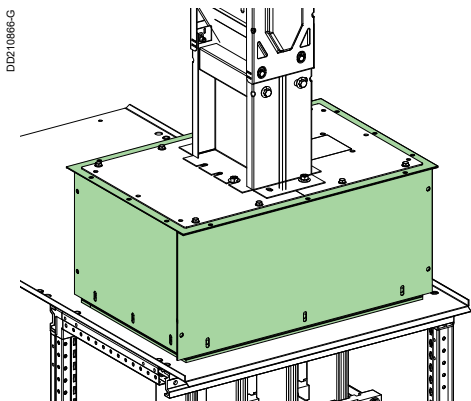

### Protective covers - Types CS, CR, BC

Protects the external part of the connection.

■ Type CS

Height adaptable flexible protective cover adaptable for ER N1 to N6 feed units with a between centres distance of 115 mm.

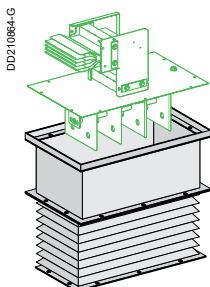

### For a vertical incomer - Types CR1 to CR3

Made-to-measure rigid protective cover for ER N1 to N7 feed units. They are height adjustable by  $\pm 50$  mm.

■ Type CR1 for a horizontal incomer.

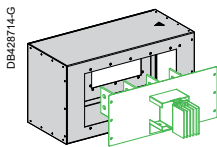

■ Types CR2 and CR3 for a vertical incomer.

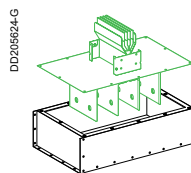
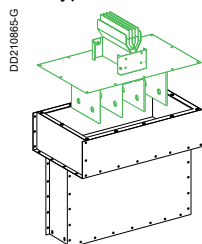

■ Types CR7 and CR8

Protective covers for Minera oil immersed transformers.

Only for ER N1 to N6 feed units with a between centres distance of 150 or 170 mm depending on the rating.

Fit directly onto the BT series transformer tanks.

**Never use with HV porcelaine bushings.**

□ Type CR8 for a vertical incomer.

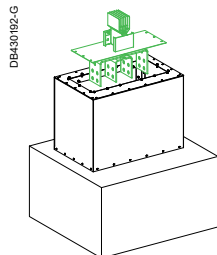

□ Type CR7 for a horizontal incomer.

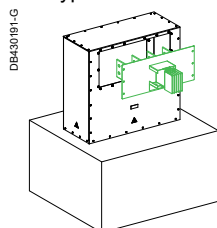

□ Type BC

Protective cover for direct cable connection to ER N1 to N6 feed units with a between centres distance of 115 mm.



### Canalis KTA

#### Universal connections to dry type transformers

A

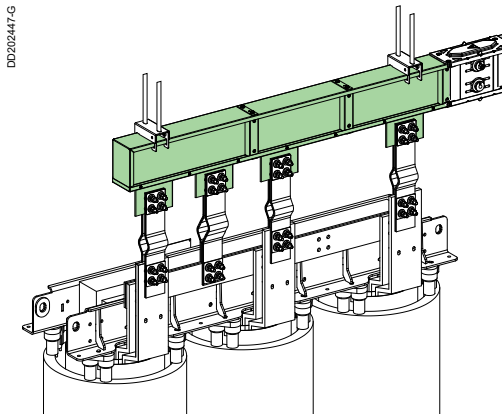

B

C

D

E

F

G

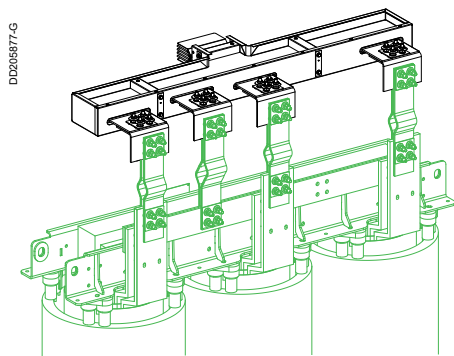

#### Feed units - Type EL

For dry type transformers with the neutral between the phases. They allow optimum connection to the busbar trunking.

The junction with the busbar trunking is achieved:

- either from the side

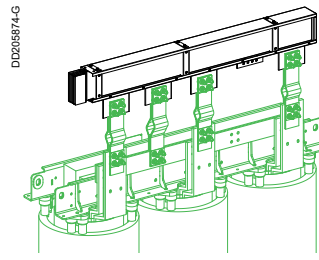

Type EL N1/N2.

- or from the centre.

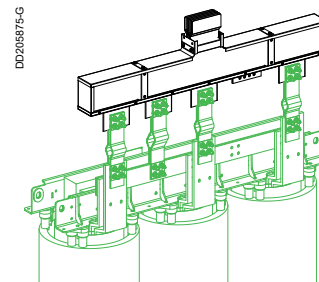

Type EL N3/N4.

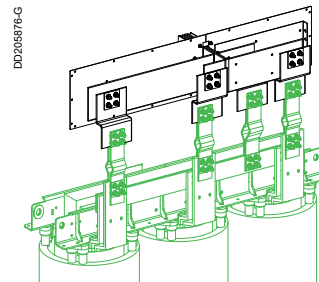

Type EL N5.

They are of similar design to straight transport sections and can be installed edgewise or flat. If installed flat, a set of angle brackets can be ordered.

The following must be specified at the time of order:

- phase order
- distance between phases (a  $\pm 20$  mm lateral adjustment can be made use of on site).

The link between the transformer terminals and the connection section is either by flexible bar connection plates or by braids.

- EL N1 to N4 customer connections are tin plated aluminium.
- ER N5 Customer connections are bare copper.

### Protective covers - Type CR4 to CR6

These protect the connections with an IP31 casing when connecting to a transformer.

They are height adjustable by  $\pm 50$  mm.

#### ■ Type CR4

Protective cover for EL N1 to N4 feed units.  
Edgewise assembly.

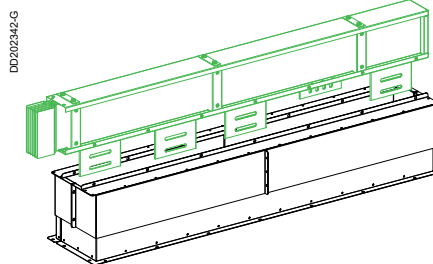

#### ■ Type CR5

Protective cover for EL N1 to N4 feed units.  
Flat assembly.

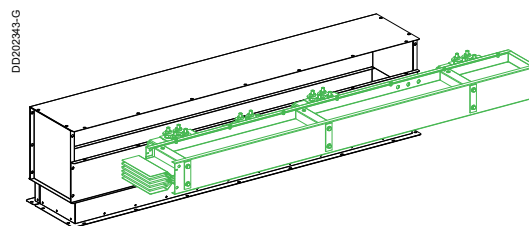

#### ■ Type CR6

Protective cover for EL N5 feed unit.  
Edgewise assembly.

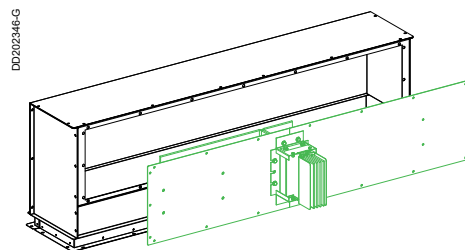

A

B

C

D

E

F

G

### Canalis KTA

#### Accessories for direct connection to the switchboard

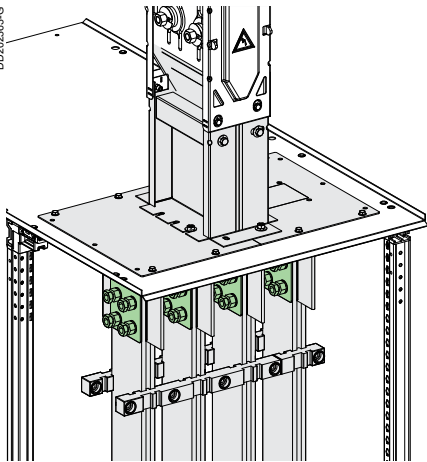

The conductors of ER N1 to N6 feed units are connected directly to the switchboard busbars. YB2 copper spacers are available to compensate differences in thickness between the switchboard bars (10 mm) and the connection part (6 mm).

#### Make-up of kit:

- 8 x 2 mm thick copper spacers
- 16 off M12 x 60 mm bolts, class 8.8
- 16 contact washers
- 16 torque nuts
- 8 steel spacer plates.

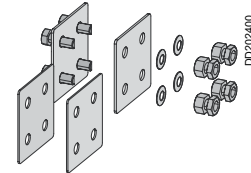

Order a set per feed unit whatever the rating.

#### Switchboard connection accessories using connection plates

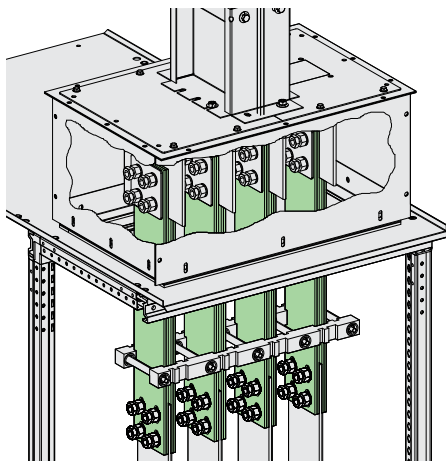

The conductors of ER N1 to N6 feed units are connected via connection plates to the switchboard busbars.

The YC are flexible bars made up of 5 copper sheets of 1 x 100/120 mm or of 5 bimetal aluminium/copper sheets 1.4 x 100/120 mm.

The number of connection plates needed is proportional to the busbar trunking rating.

There are 2 types:

- YC1, uninsulated bar, made-to-measure length of 300 to 600 mm with 4 oblong holes at the ER unit end.

The holes at the opposite side are made to measure to match with the switchboard connections.



- YC5, insulated 600 or 1000 mm long flexible bar, stripped at one end and with 4 oblong holes.

The length of the holes at the switchboard side are to be adapted on-site.



#### Nuts and bolts

The connection plates are fixed to the feed unit using the YB3 nut and bolt kit, made up of:

- 16 off M12 x 60 mm bolts, class 8.8
- 16 contact washers
- 16 torque nuts
- 8 steel spacer plates.

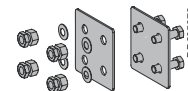

#### Clamps

YS1 clamps enable high short-circuit current levels to be withstood; only for bars with a 115 mm spacing.

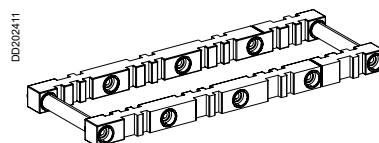

#### Insulation

See page 41.

### Transformer connections - Types YC, YT

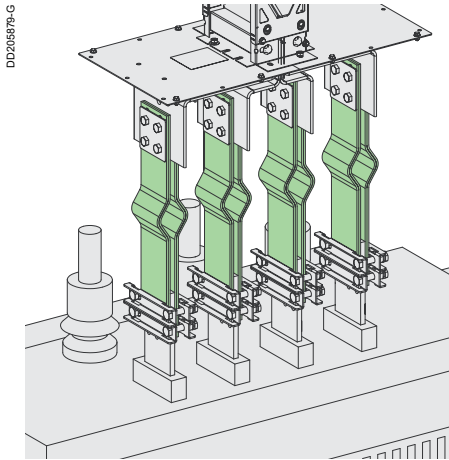

DD202679-G

The feed unit conductors are connected to the transformer bars via connection plates or braids:

- the YC are flexible bars made up of 5 copper sheets 1 x 100/120 mm or of 5 bimetal aluminium/copper sheets 1.4 x 100/120 mm.
- braids, YT type, are copper braids with a 600 mm<sup>2</sup> cross-section.

The number of connection plates needed is proportional to the busbar trunking rating.

#### Connection plates

The YC3 is an uninsulated bar with an expansion kink; it is 250 to 600 mm long and has 4 holes at the ER unit end.

The holes at the opposite side are made-to-measure to match with the transformer connections.

They can be fitted to the transformer side:

- either using bar clamps (no drilling),
- or drilled and bolted (to be carried out on site).



DD202412

YS2 and YS3 bar clamps enable connection without the need to drill the connection plates.

They allow height adjustment.

- Type YS2, bar clamps for 100 mm transformer connection terminals.
  - Type YS3, bar clamps for 120 mm transformer connection terminals.
- Make-up of kit: 1 set of 8 parts.

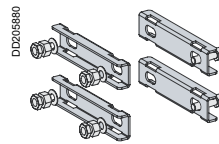

DD205880

#### Braids

Type YT, 400 mm long insulated braid with 4 holes at each end.

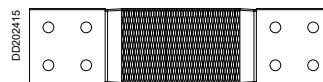

DD202415

The connection plates and braids are fixed to the feed unit using the YB4 nut and bolt kit, made up of:

- 16 off M12 x 80 mm bolts, class 8.8
- 16 contact washers
- 16 torque nuts
- 8 steel spacer plates.

#### Insulation

The YF conduit allows the various conductors of a connection performed with braids or with bare copper foils to be insulated.

Installation is performed after complete assembly of the connection, with scratch fastening for easier setup.

The insulating conduit is formed of a 2-metre plastic duct that can be cut to length as needed.

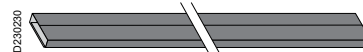

DD230230

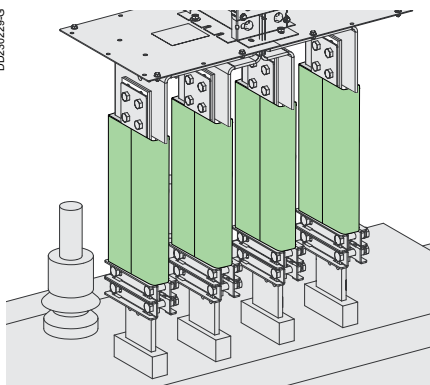

DD230225-G

A

B

C

D

E

F

G

### Canalis KTA

#### Horizontal supports

A

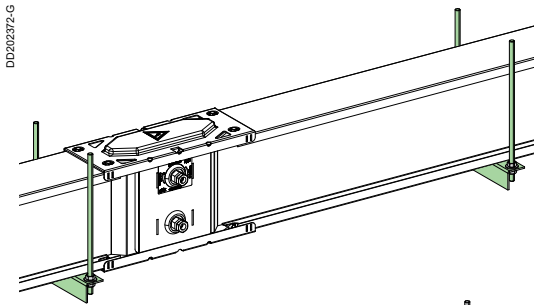

The ZA types allow the busbar trunking to be fixed and adjusted along its length, as well as absorbing its movements.

#### Supports for horizontal sections

- Type ZA1, to support edgewise busbar trunking only, consists of a steel angle bracket and 2 x 2 metre threaded M10 rods.
- The maximum distance between supports is:
  - 3 metres for edgewise busbar trunking
  - 2 metres for flat busbar trunking.
- See installation precautions.

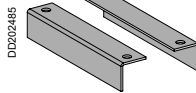

B

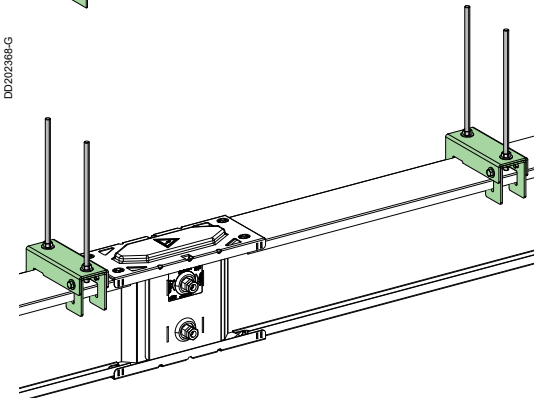

- Type ZA4, to support the busbar trunking from the top.
- These supports are needed to fix edgewise EL N1 to N4 feed units for dry type transformers (rods not supplied).

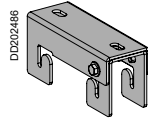

C

D

E

F

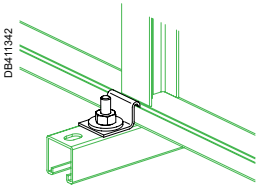

#### Fixing bracket

The ZA3 keeps the busbar trunking in place on its support, without blocking it, in order to allow expansion movements.

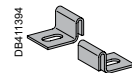

#### Vertical supports

G

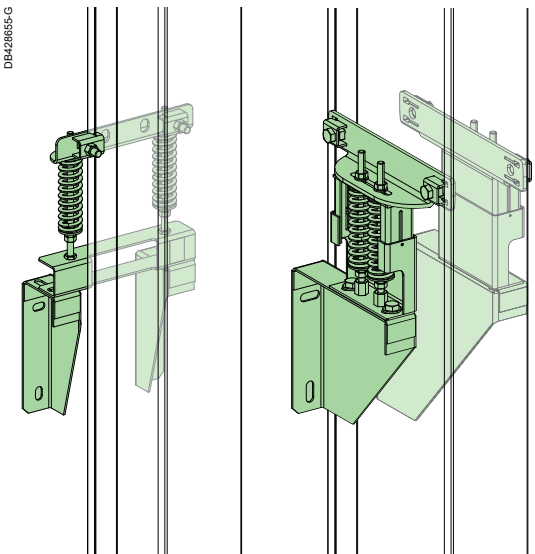

The ZA5 is for supporting vertical sections. They fix sections of a vertical run to the building's structure. This type of fixing support has the following advantages:

- assembly:
  - to a wall
  - to a wall bracket
  - to the floor
- height and depth adjustment
- spring adjustment to ensure distribution of the load at each floor
- avoids the transmission of building forces to the busbar trunking (expansion and vibration).

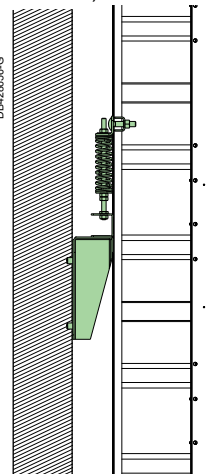

To a wall bracket  
KTB0164ZA5●.

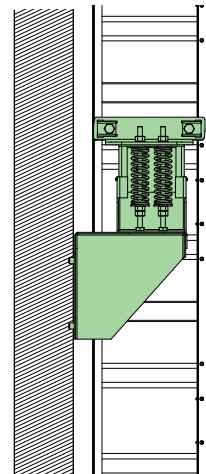

To a wall bracket  
KTB0204ZA5● to  
KTB0404ZA5●.

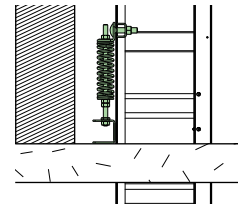

To the floor  
KTB0164ZA51.

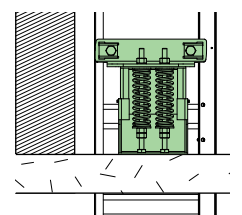

To the floor  
KTB0204ZA51 to  
KTB0404ZA51.

The tap-off units are used to instantly connect loads or secondary runs, and comply with installation standards and regulations (IEC 60364), whatever the earthing system (TT, TNS, TNC or IT).  
When off-load, they can be plugged-on and off and be operated whilst live. Plugging-on and plugging-off automatically opens and closes the tap-off point.

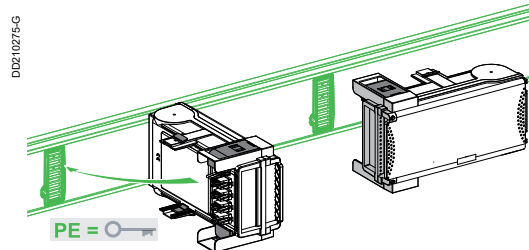

No live part is accessible with the door open. The protection degree is IPXXB (finger protection).  
They are IP55 by construction (no accessory is required).

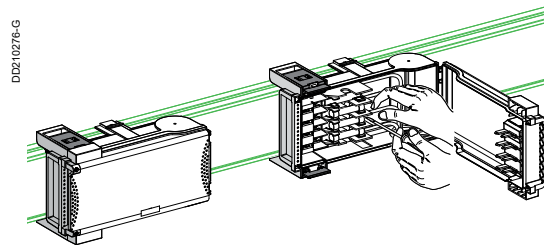

### Safety and operation

Fuse and modular switchgear tap-off units (AC20) are isolated as soon as the tap-off unit door is opened.

**Tap-off unit disconnection by opening or closing the cover should be carried out only if the downstream load is de-energised.**

For circuit breaker tap-off units, there are safety mechanisms to prevent:

- the tap-off unit being plugged-on and plugged-off with the tap-off unit door closed
- the door being closed if the tap-off unit has not been locked onto the busbar trunking
- access to the electrical equipment and connection terminals when live
- the door being opened in the "ON" position for tap-off units fitted with a Compact NS or NSX or NG circuit breaker.

These tap-off units can be fitted with accessories such as:

- door early break contacts
- adapter for lead sealing
- etc.

The sheet steel tap-off units are fitted with a carrying handle.

### Characteristics of tap-off units up to 100 A

- Colour:
  - white (RAL 9001) body and carrying handles
  - transparent green door (similar design to the Kaedra enclosures).
- Material: self-extinguishing, halogen-free insulating plastic (fire resistant and very high temperature withstand).

Other characteristics: cable gland drilling zone, stainless steel screws and the door can be lead sealed.

### Characteristics of tap-off units from 160 to 400 A

- Colour:
  - white (RAL 9001) body
  - black carrying handles (RAL 9005)
  - 100 % polyester paint
- Material: galvanized sheet steel.

Other characteristics:

- unhingeable door (120° opening hinges)
- vertically bevelled polyurethane seals with a double fold for increased rigidity (similar design to the Sarel Spatial 3D enclosures)
- 25 mm grill type gland plates for a maximum access area.

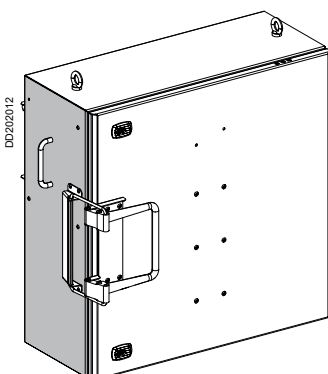
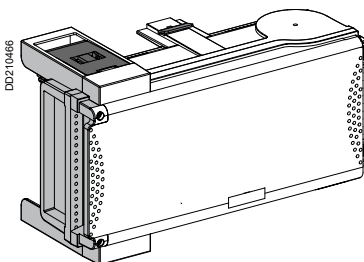

A

B

C

D

E

F

G

## Description

# Plug-on tap-off units for circuit breakers

### Canalis KTA

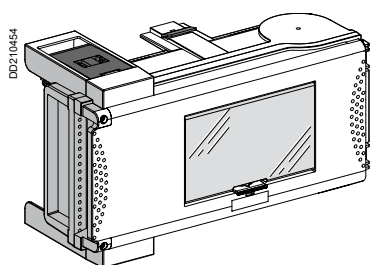

#### Isolator tap-off units for modular switchgear

Most 18 mm Multi 9 modular devices can be fitted into these tap-off units. They have a window on the front face for switchgear control and visualisation.

A transparent shutter ensures the window can be sealed.

Two tap-off ratings are available:

- 63 A nominal current for 8 modules
- 100 A nominal current for 12 modules (accepts C120 circuit breakers).

A

B

C

D

E

F

G

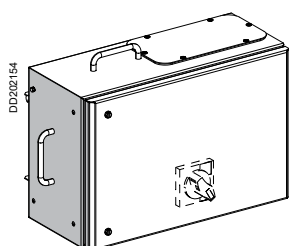

#### Tap-off units for NG type modular switchgear

These tap-off units are fitted with a DIN rail and upstream connections for 18 mm wide modular devices.

The switchgear is operated via a rotary handle which prevents door opening when the circuit breaker is in the "ON" position.

Nominal current: 160 A for a 13-module capacity (accepts NG125 or NG160 fitted with a Vigi unit).

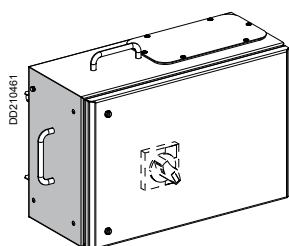

#### Isolator tap-off units for Compact NSX circuit breakers

These tap-off units are fitted with mounting plates and upstream connections for fixed, front-connected 100 to 630 A Compact NSX circuit breakers (N, H or L version) with a rotary handle.

The 400 A tap-off units can only be fitted onto straight lengths with a rating greater than 400 A.

For plug-on circuit breakers, Vigi units, etc, please consult your Schneider Electric contact.

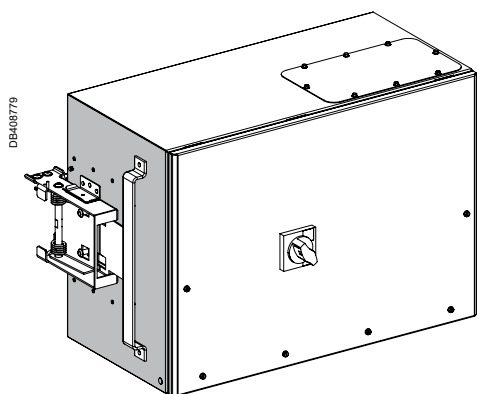

#### Measurement and metering isolator tap-off units

These tap-off units allow sub-metering to re-allocate power consumption costs by consumer and to monitor installations by, for example, following run load levels. The values measured using the Compact NSX TI unit are sent to the measurement unit which then sends the information to a central unit via a bus (see Measurement and metering).

They are fitted with:

- a mounting plate for a Compact NSX250 or 400 A circuit breaker with an extended rotary handle and a Compact NSX current transformer module (TI unit)
- a DIN rail for installing a Powerlogic PM810 measurement unit, a set of terminals, etc.

In severe operating conditions (> 40 °C ambient temperature), we recommend the use of a PM810 without display.

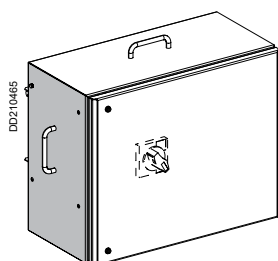

# Plug-on tap-off units for fuses

These tap-off units provide the tap-offs with fuse protection (fuses not supplied).

## Plastic tap-off units

Fitted with carriers for:

- 50 to 100 A cylindrical NF fuses
- 25 to 63 A DIN screwed fuses
- 100 A DIN blade fuses
- 32 to 80 A BS screwed fuses.

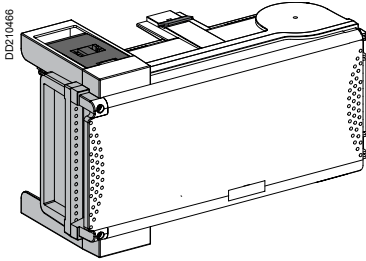

## Steel tap-off units

Fitted with carriers for:

- 160 to 400 A NF/DIN blade fuses
- 160 A BS screwed fuses
- fuses disconnecter 630 A.

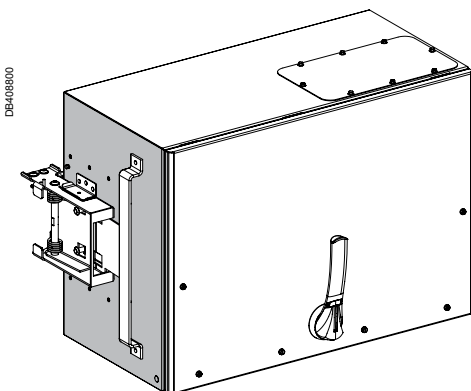
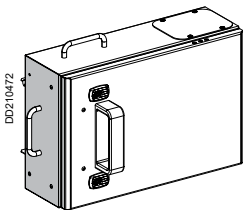
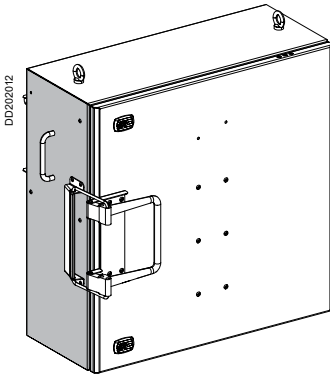

A

B

C

D

E

F

G

## Description

# Fixed tap-off units for circuit breakers

## Canalis KTA

### Safety and operation

The electrical connection is made by plugging-on the tap-off unit into dedicated tap-off point whilst the busbar trunking is de-energised (plugging-off the unit must also be done with the busbar trunking de-energised).

The connection is mechanically tightened using a one-use torque bolt (10 daN.m).

A mechanical foolproof system avoids the risk of incorrect assembly.

The door can only be opened once the load has been isolated (rotary handle).

The bolt can only be tightened or untightened with the door open.

No live part is accessible with the door open, protection degree IP2X.

### Characteristics of tap-off units from 400 to 1250 A

- Colour:
  - white (RAL 9001) body
- Material: galvanized sheet steel.
- Other characteristics:
  - the cables exit laterally through 2 aluminium plates (to be drilled by the installation contractor)
  - cabling space can be increased by using the cable box supplied with the tap-off unit
  - the door is fixed using 6 captive M6 screws and can be completely removed to facilitate cabling.

### Steel tap-off units

These tap-off units are used to supply loads or secondary runs (e.g. medium power distribution using Canalis KS).

They are fitted to specific EB type straight lengths.

They comply with installation standards and regulations, whatever the earthing system (TT, IT, TNS or TNC):

- tap-off units fitted with a mounting plate for Compact NS and NSX 400 / 1250 A, 3 or 4 P:
  - fixed device
  - front connections
  - extended rotary handle.

3 models:

- Compact NSX400/630 A, connection capacity:
  - IP54
  - 3 x 300 mm<sup>2</sup> cables for the phases and neutral (hole diameter = 15 mm)
  - 150 mm<sup>2</sup> for the PE
- Compact NS800/1000 A, connection capacity:
  - IP54
  - 4 x 300 mm<sup>2</sup> cables for the phases and neutral (hole diameter = 15 mm)
  - 200 mm<sup>2</sup> for the PE (cable clamp)
- Compact NS1250 A, connection capacity:
  - IP31
  - 4 x 300 mm<sup>2</sup> cables for the phases and neutral (hole diameter = 15 mm)
  - 200 mm<sup>2</sup> for the PE (cable clamp).

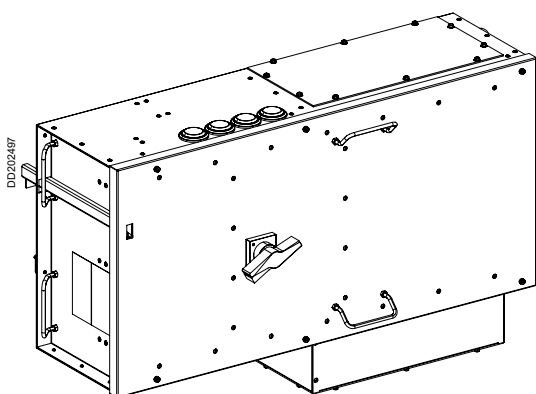
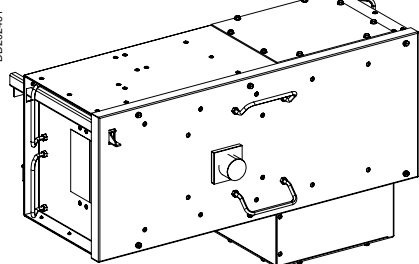

# Catalogue numbers and dimensions

Introduction	3
Presentation and description	23
<b>Catalogue-number coding</b>	<b>48</b>
<b>Canalis KTA 5000 A</b>	<b>49</b>
<b>Run components</b>	<b>50</b>
<b>Additional run components</b>	<b>56</b>
<b>Elbow components for changing direction</b>	<b>60</b>
<b>Zed components for changing direction</b>	<b>66</b>
<b>Fire rated straight feeder lengths</b>	<b>70</b>
<b>Fire rated Jointing units</b>	<b>71</b>
<b>Fire rated flat elbows</b>	<b>72</b>
<b>Fire rated edgewise elbows</b>	<b>73</b>
<b>Canalis interfaces for PrismaSeT LV switchboard</b>	<b>74</b>
<b>Canalis interfaces for Okken LV switchboard</b>	<b>77</b>
<b>Sealing kits</b>	<b>78</b>
<b>Feed units for switchboards and oil immersed transformers</b>	<b>79</b>
<b>Rigid protective covers</b>	<b>86</b>
<b>Adjustable protective covers for Minera immersed transformers</b>	<b>88</b>
<b>Flexible protective covers, Cable boxes</b>	<b>90</b>
<b>Feed units for dry-type transformers</b>	<b>92</b>
<b>Protective covers for dry-type transformers</b>	<b>97</b>
<b>Connection accessories</b>	<b>100</b>
<b>Supports and fixings</b>	<b>106</b>
<b>Accessories</b>	<b>109</b>
Fire-barrier kit	109
<b>Plug-in tap-off units</b>	<b>110</b>
63 to 100 A tap-off units for modular devices	110
160 A tap-off units for modular devices	111
160 to 400 A tap-off units for Compact NSX circuit breakers	112
250 to 400 A tap-off units for Compact NSX circuit breakers	113
630 A tap-off units for Compact NSX circuit breakers	114
50 to 100 A tap-off units for NF fuses	115
100 to 400 A tap-off units for NF fuses	116
25 to 63 A tap-off units for DIN fuses	117
100 to 400 A tap-off units for DIN fuses	118
630 A tap-off units with switch disconnecter for DIN fuses	119
32 to 160 A tap-off units for BS fuses	121
Accessories	122
<b>Bolted tap-off units</b>	<b>123</b>
For Compact NSX/NS circuit breakers	123
With switch-disconnectors for DIN fuses	124
<b>Coupling isolators from 1000 to 2500 A</b>	<b>125</b>
<b>2500 A internal arcing resistant coupling isolator</b>	<b>126</b>
<b>Coupling isolators 3200 A</b>	<b>127</b>
<b>Protection of the run using Compact NS circuit breakers from 1000 à 1600 A</b>	<b>128</b>
<b>Special products</b>	<b>129</b>
<b>Canalis KH substitution by Canalis KT</b>	<b>131</b>
KTA/KHF connection elements	131
Preserved KH tap-off units and substitution table	132
<b>Canalis KH Plug-in tap-off units</b>	<b>135</b>
For Compact NSX circuit breakers	135
With switch-disconnectors for DIN fuses	136
With disconnecter Jean Muller	138
<b>Expansion of a Canalis KH line by means of Canalis KT</b>	<b>139</b>
<b>Expansion of a Canalis KH line by means of Canalis KT with a T-piece tap-off unit</b>	<b>140</b>
<b>Mid KT line power supply with KH tap-off units installed</b>	<b>141</b>
Design guide	143
Installation guide	185
Recommendations	243
Index	248

### Canalis KTA

#### Catalogue-number composition

■ One letter designating the material.

Type	Code
Aluminium	A
Non conducting	B
Copper	C



■ Four digits indicating the rating of the trunking.  
**Important:** for an 800 A rating, indicate "KTA0800".

■ Two letters identifying the type of component.

Type	Code
Cable box	BC
Bolted tap-off unit	CB
Fire-barrier	CF
Edgewise and flat zed	CP
Rigid protective cover	CR
Flexible protective cover	CS
Expansion unit	DB
Tap-off unit for Compact NSX	DC
Distribution length for bolt-on tap-off units	EB
Distribution length for plug-in tap-off units	ED
Distribution length for KH plug-in tap-off units	EH
Feed unit for dry-type transformers	EL
Feed unit	ER
Feeder length	ET
End cover	FA
Bolted tap-off unit for fuses	HF
Connection KH/KT	HT
Edgewise elbow	LC
Flat elbow	LP
PER for PrismaSeT and Okken interfaces	PE
Tap-off unit with protective device	PL
Tap-off unit with fuse disconnectors	SD
Tap-off unit with switch-disconnector	SE
Tap-off unit with isolator	SL/RL
Edgewise tee	TC
Neutral crossover	TN
Phase crossover	TP
Sealing kit	TT
Connection device	YA
Connection torque nut kit	YB
Flexible bar	YC
Bracket	YE
Insulating sheath	YF
Connection plate	YP
Bar supports	YS
Braids	YT
Supports and fixing devices	ZA
Edgewise zed	ZC
Flat zed	ZP

■ One digit indicating the trunking polarity

Polarity	PE protective conductor <sup>(1)</sup>	Short circuit level <sup>(1)</sup>	Code
3L + PE	Standard	Standard <sup>(2)</sup>	3
3L + N + PE	Standard	Standard	4
3L + N + PE	Standard	Reinforced	6 <sup>(3)</sup>
3L + N + PER	In aluminium	Standard	5
3L + N + PER	In copper	Reinforced	7

(1) For further information, see page 144 "Characteristics".

(2) Reinforced version in 2000 and 2500 A.

(3) Reinforced version in 2500 and 3200 A only.

■ Variable number of alphanumeric characters indicating characteristics specific to the component.  
 See the section dealing with the given component.

■ Fire rated components.

Type	Code
Fire rated straight feeder length	FT
Fire rated edgewise elbow	FC
Fire rated flat elbow	FP
Fire rated connection device	FJ

#### Trunking cross section

Rating (A)	800	1000	1250	1600	2000	2500	3200	4000	5000
Number of bar jointing bolts	1	1	1	2	2	2	4	4	4
Bar cross-section (mm)	70 x 6	100 x 6	120 x 6	160 x 6	200 x 6	2 x (120 x 6)	2 x (160 x 6)	2 x (200 x 6)	4 x (120 x 6)
Trunking height H (mm)									

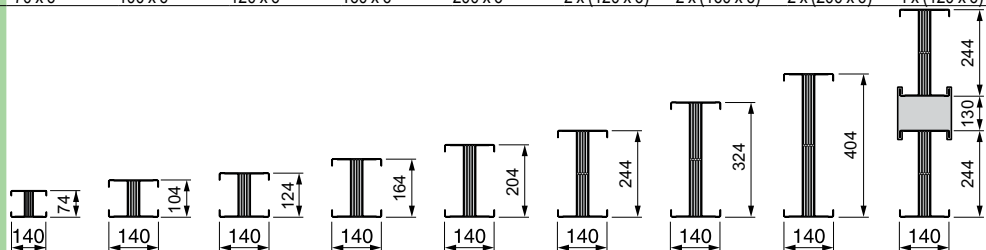

#### Holes for connections (mm)

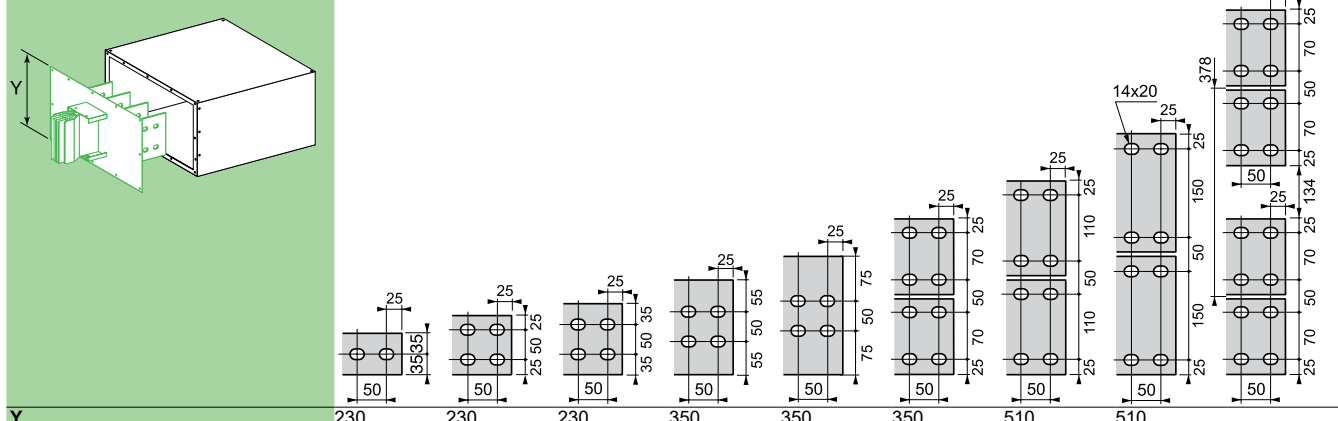

### Canalis KTA

DB411146

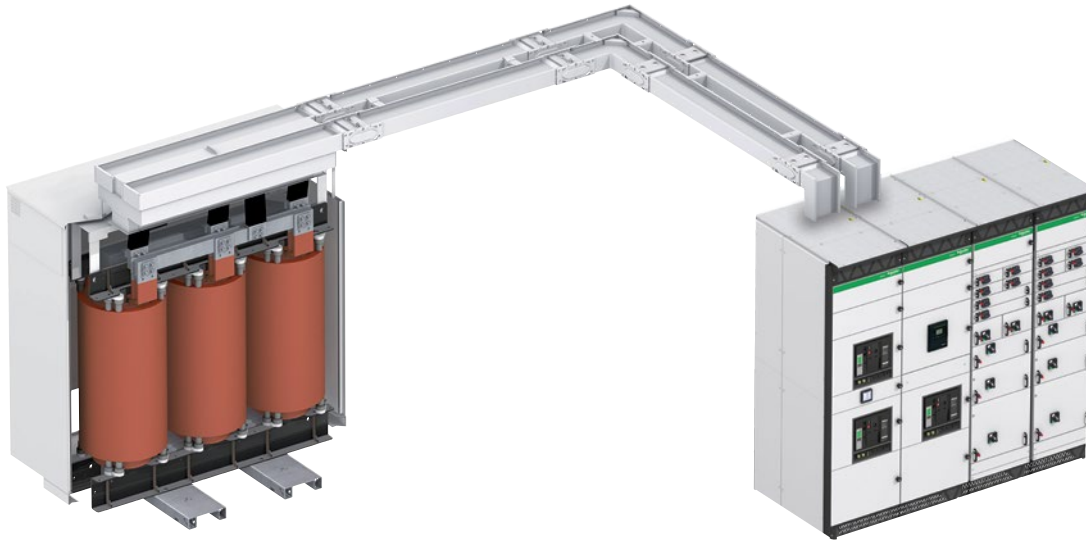

KTA5000 A is made of 2 units KTA2500 A linked together thanks to guide supports GS.  
For KTA5000 A ratings contact sales office for quotation.

DB429011

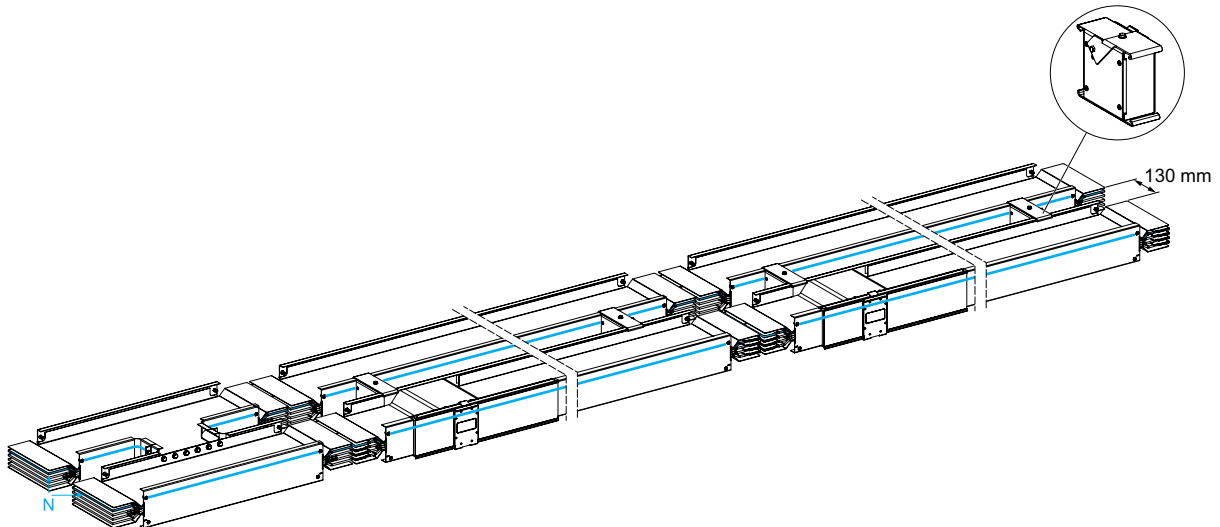

The current has to be re-balanced between the 2 runs in distribution applications.

DB429012-G

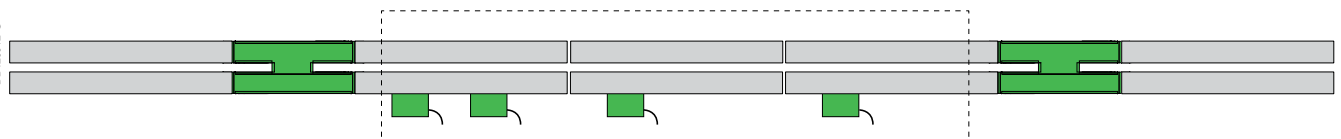

If the total load of a group of tap-off units is above 1600 A, then add bridges (edgewise H units) between the 2 runs.  
Bridges have to be placed before and after the group.



# Run components IP55

## Canalis KTA 800 to 4000

A  
B  
C  
D  
E  
F  
G

### Ordering

Complete the catalogue number by replacing "●●●●" by the rating.

#### Important:

- for the 800 A rating, add a "0" in the catalogue number: **KTA0800**
- add the dimensions of the selected component as a technical comment.

**Example:** the catalogue number of an 800 A feeder length, 3L + N + PE, 2450 mm long, is:

**KTA0800ET42C, L = 2450**

Rating

### ET - Straight feeder lengths

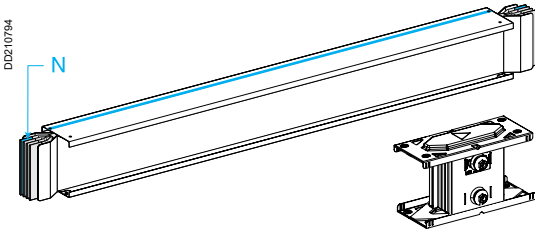

KTA●●●●ET●●●

Type	Length "L" (mm)	Cat. no.		
		3L + PE	3L + N + PE <sup>(2)</sup>	3L + N + PER <sup>(1)</sup>
Fixed	2000	KTA●●●●ET320	KTA●●●●ET420	KTA●●●●ET520
	4000	KTA●●●●ET340	KTA●●●●ET440	KTA●●●●ET540
Made to measure	500 to 1500	KTA●●●●ET31A	KTA●●●●ET41A	KTA●●●●ET51A
	1501 to 1999	KTA●●●●ET32B	KTA●●●●ET42B	KTA●●●●ET52B
	2001 to 2500	KTA●●●●ET32C	KTA●●●●ET42C	KTA●●●●ET52C
	2501 to 3000	KTA●●●●ET33D	KTA●●●●ET43D	KTA●●●●ET53D
	3001 to 3500	KTA●●●●ET33E	KTA●●●●ET43E	KTA●●●●ET53E
	3501 to 3999	KTA●●●●ET33F	KTA●●●●ET43F	KTA●●●●ET53F

(1) To order the 3L + N + PER version with reinforced Isc, replace KTA●●●●ET5●● by KTA●●●●ET7●●.

(2) To order the 3L + N + PE 2500 A and 3200 A version with reinforced Isc, replace KTA2500ET4●● by KTA2500ET6●● and KTA3200ET4●● by KTA3200ET6●●.

KTA●●●●ET●●●

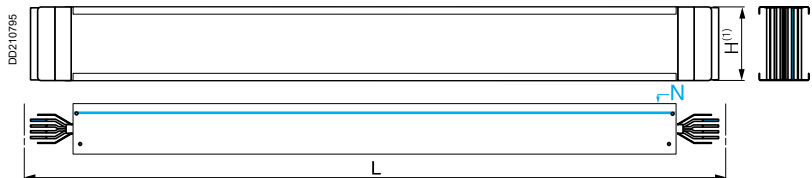

(1) See the "Trunking cross-section" table page 52.

### ED - Straight lengths for KS plug-in tap-off units

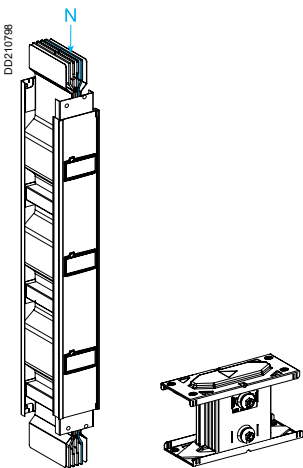

KTA●●●●ED●●●●

Type	Length "L" (mm)	Number of tap-offs	Cat. no.		
			3L + PE	3L + N + PE <sup>(2)</sup>	3L + N + PER <sup>(1)</sup>
Fixed	2000	1	KTA●●●●ED3201	KTA●●●●ED4201	KTA●●●●ED5201
		3	KTA●●●●ED3203	KTA●●●●ED4203	KTA●●●●ED5203
		4000	3	KTA●●●●ED3403	KTA●●●●ED4403
Made to measure	2500 to 3000	1	KTA●●●●ED3301	KTA●●●●ED4301	KTA●●●●ED5301
	3000 to 3001	2	KTA●●●●ED3302	KTA●●●●ED4302	KTA●●●●ED5302
	3001 to 3500	1	KTA●●●●ED3351	KTA●●●●ED4351	KTA●●●●ED5351
	3500	3	KTA●●●●ED3353	KTA●●●●ED4353	KTA●●●●ED5353

(1) To order the 3L + N + PER version with reinforced Isc, replace KTA●●●●ED5●●● by KTA●●●●ED7●●●.

(2) To order the 3L + N + PE 2500 A and 3200 A version with reinforced Isc, replace KTA2500ED4●●● by KTA2500ED6●●● and KTA3200ED4●●● by KTA3200ED6●●●.

KTA●●●●ED●201

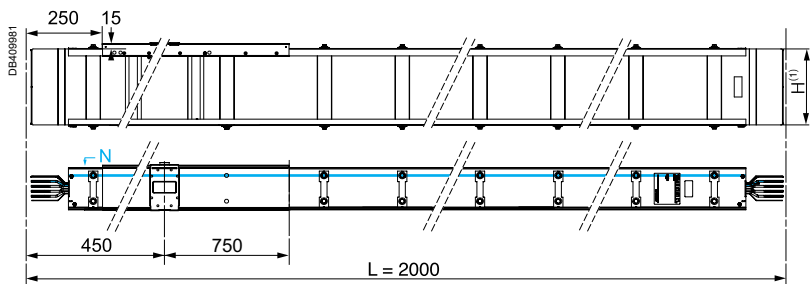

KTA●●●●ED●203

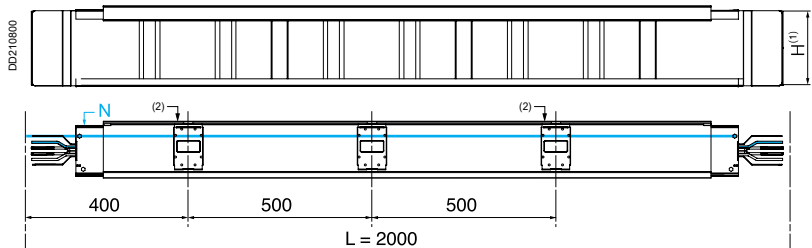

(1) See the "Trunking cross-section" table page 52.

(2) Tap-off units KTB0630●●● can not be installed at this outlet.

### Canalis KTA 800 to 4000

#### Straight lengths for KS plug-in tap-off units

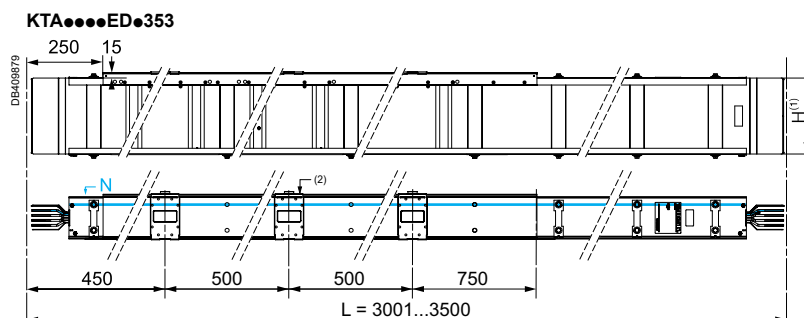
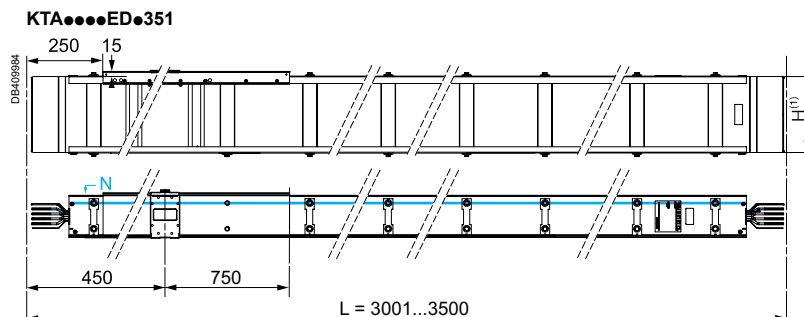
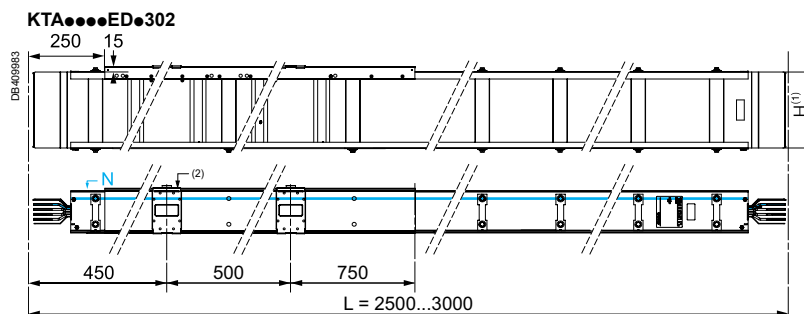
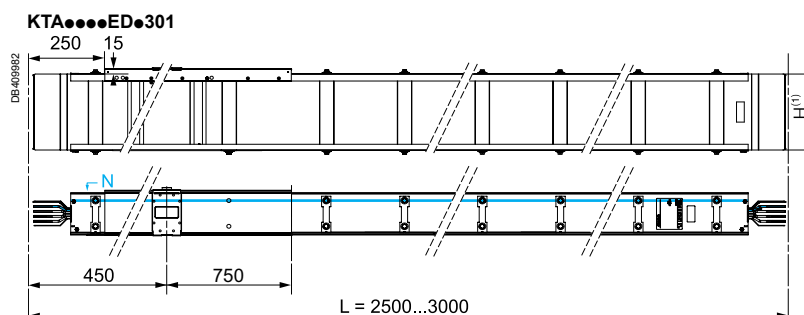
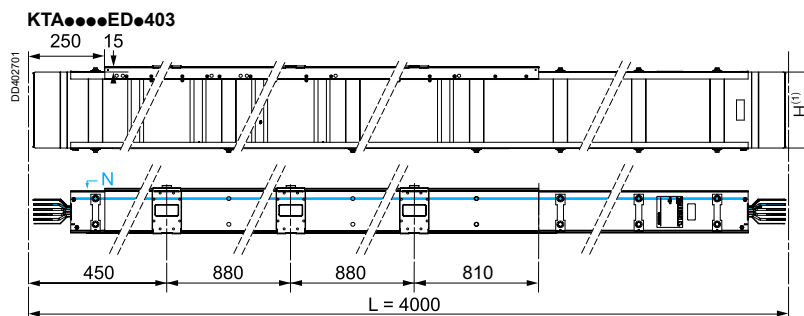

(1) See the "Trunking cross-section" table page 52.  
 (2) Tap-off units KTB0630●●● can not be installed at this outlet.



# Run components IP55

## Canalis KTA 800 to 4000

### EB - Straight lengths for bolted tap-off units

A

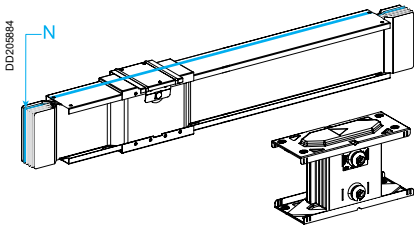

KTA...EB20

B

C

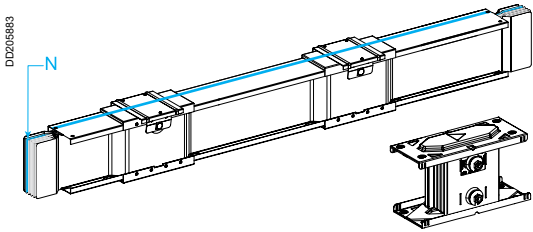

KTA...EB40

D

E

F

G

Type	Length "L" (mm)	Number of tap-offs	Cat. no.		
			3L + PE	3L + N + PE <sup>(2)</sup>	3L + N + PER <sup>(1)</sup>
Fixed	2000	1	KTA...EB320	KTA...EB420	KTA...EB520
	4000	2	KTA...EB340	KTA...EB440	KTA...EB540

(1) To order the 3L + N + PER version with reinforced Isc, replace KTA...EB5... by KTA...EB7....

(2) To order the 3L + N + PE 2500 A and 3200 A version with reinforced Isc, replace KTA2500EB4... by KTA2500EB6... and KTA3200EB4... by KTA3200EB6....

#### KTA...EB20

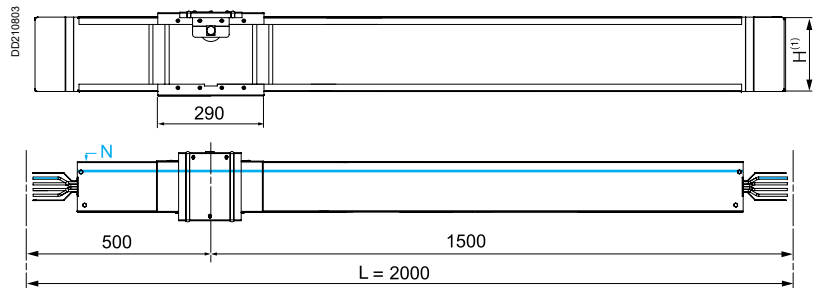

#### KTA...EB40

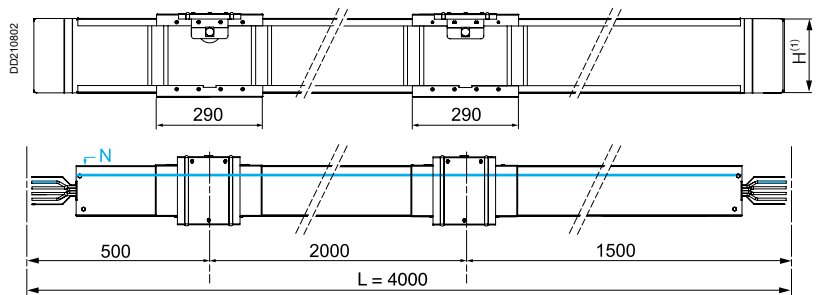

(1) See the "Trunking cross-section" table below.

### Trunking cross-section

Rating (A)	800 <sup>(1)</sup>	1000	1250	1600	2000	2500	3200	4000	5000
Weight (kg/m)									
3L + PE	12	14	16	19	22	25	31	38	50
3L + N + PE	13	16	18	22	26	30	37	45	60
3L + N + PER	15	19	21	26	31	36	46	56	72

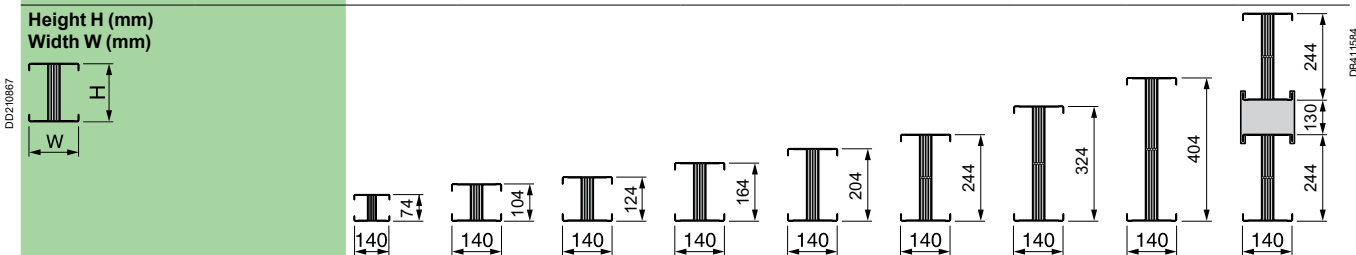

(1) Important: for the 800 A rating, indicate "KTA0800".

### Canalis KTA 800 to 4000

#### Ordering

Complete the catalogue number by replacing the "●●●●" with the rating.

**Important:** in the catalogue number, for a rating of 800 A, add a "0": KTA0800.

**Example:** a transport section 800 A, length 4 m.

Catalogue number for 3L + N + PE: **KTA0800EH440**.

#### EH - Straight lengths for KH plug-in tap-off units

Type	Length "L" (mm)	Number of tap-offs	Cat. no. <sup>(4)</sup>		
			3L+PE	3L + N + PE <sup>(2)</sup>	3L + N + PER <sup>(3)</sup>
Fixed	2000	2	KTA●●●●EH320	KTA●●●●EH420	KTA●●●●EH520
	4000	3	KTA●●●●EH340	KTA●●●●EH440	KTA●●●●EH540

(1) See the "Trunking cross-section" table page 52.

(2) To order the 3L + N + PE 2500 A and 3200 A version with reinforced Isc, replace KTA2500EH4●● by KTA2500EH6●● and KTA3200EH4●● by KTA3200EH6●●.

(3) To order the 3L + N + PER 2500 A and 3200 A version with reinforced Isc, replace KTA2500EH5●● by KTA2500EH7●● and KTA3200EH5●● by KTA3200EH7●●.

(4) Not available for KTA5000.

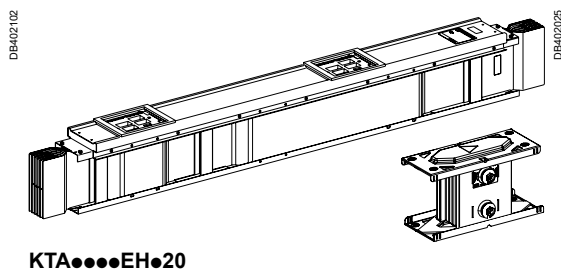

KTA●●●●EH●20

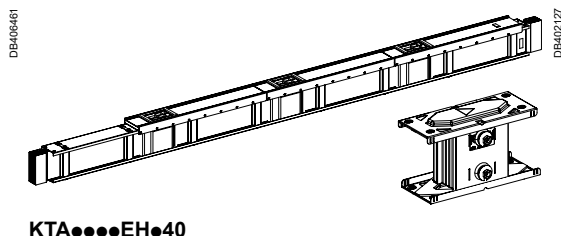
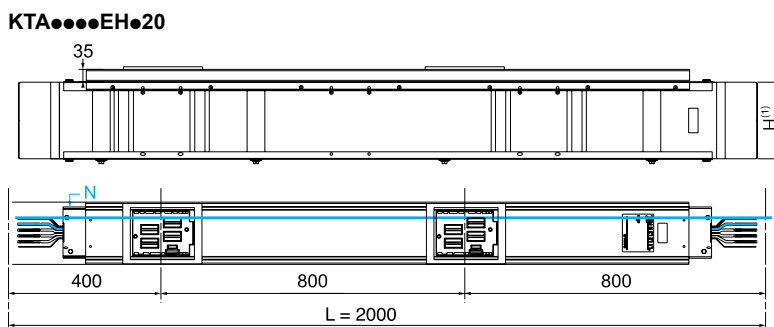

KTA●●●●EH●40

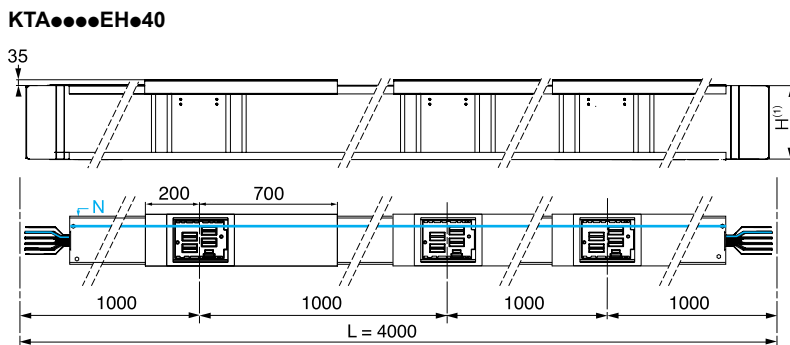

A

B

C

D

E

F

G

# Run components IP55

## Canalis KTA 5000

### ET - Straight feeder lengths

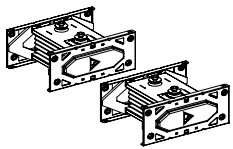
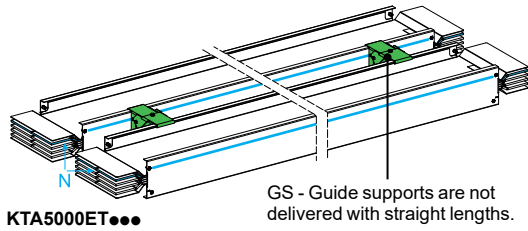

Type	Length "L" (mm)	Cat. no.		
		3L + PE	3L + N + PE	3L + N + PER <sup>(1)</sup>
Fixed	2000	KTA5000ET320	KTA5000ET420	KTA5000ET520
	4000	KTA5000ET340	KTA5000ET440	KTA5000ET540
Made to measure	500 to 1500	KTA5000ET31A	KTA5000ET41A	KTA5000ET51A
	1501 to 1999	KTA5000ET32B	KTA5000ET42B	KTA5000ET52B
	2001 to 2500	KTA5000ET32C	KTA5000ET42C	KTA5000ET52C
	2501 to 3000	KTA5000ET33D	KTA5000ET43D	KTA5000ET53D
	3001 to 3500	KTA5000ET33E	KTA5000ET43E	KTA5000ET53E
	3501 to 3999	KTA5000ET33F	KTA5000ET43F	KTA5000ET53F

(1) To order the 3L+N+PER version with reinforced Isc, replace KTA5000ET5●●● by KTA5000ET7●●●.

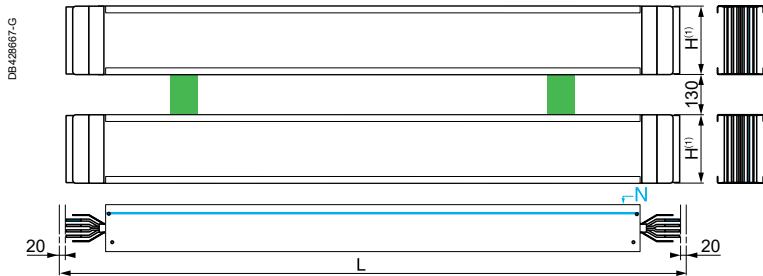

(1) See the "Trunking cross-section" table page 52.

### ED - Straight lengths for KS plug-in tap-off units

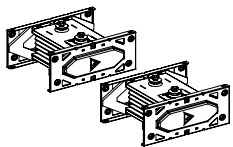
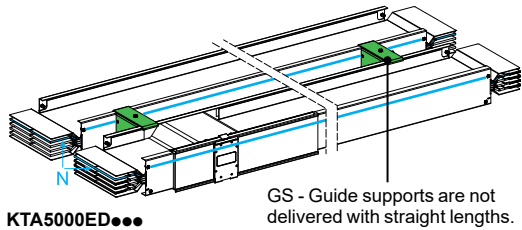

Type	Length "L" (mm)	Number of tap-offs	Cat. no.		
			3L + PE	3L + N + PE <sup>(2)</sup>	3L + N + PER <sup>(1)</sup>
Fixed	2000	3	KTA5000ED3203	KTA5000ED4203	KTA5000ED5203
	4000	3	KTA5000ED3403	KTA5000ED4403	KTA5000ED5403

(1) To order the 3L+N+PER version with reinforced Isc, replace KTA5000ED5●●●3 by KTA5000ED7●●●3.

#### KTA●●●●ED●203

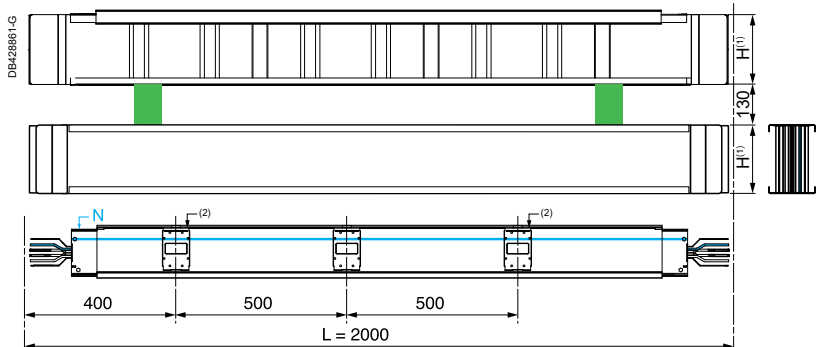

#### KTA●●●●ED●403

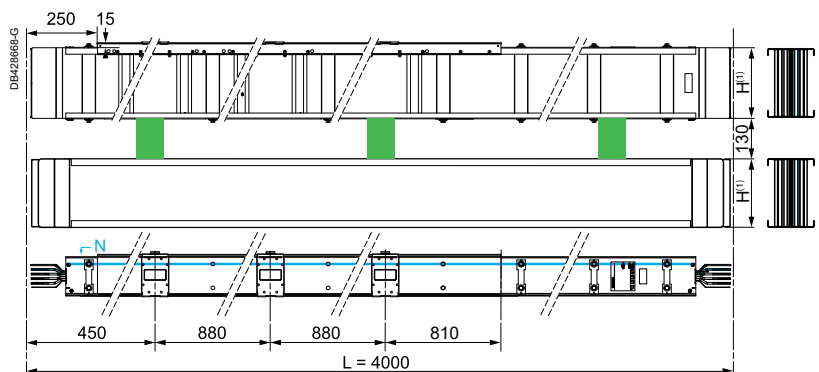

(1) See the "Trunking cross-section" table page 52.

(2) Tap-off units KTB630●●●●●● can not be installed at this outlet.

### Canalis KTA 5000

#### EB - Straight lengths for bolted tap-off units

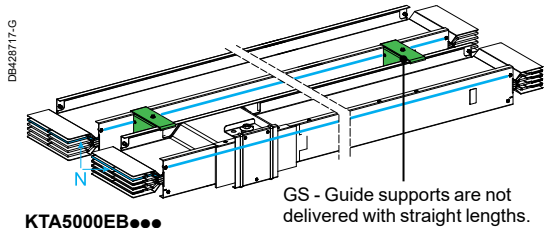

GS - Guide supports are not delivered with straight lengths.

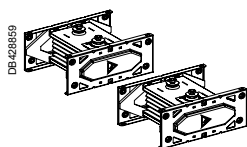

Type	Length "L" (mm)	Number of tap-offs	Cat. no.		
			3L + PE	3L + N + PE	3L + N + PER <sup>(1)</sup>
Fixed	2000	1	KTA5000EB320	KTA5000EB420	KTA5000EB520
	4000	2	KTA5000EB340	KTA5000EB440	KTA5000EB540

(1) To order the 3L + N + PER version with reinforced Isc, replace KTA5000EB5●● by KTA5000EB7●●.

#### KTA5000EB●20

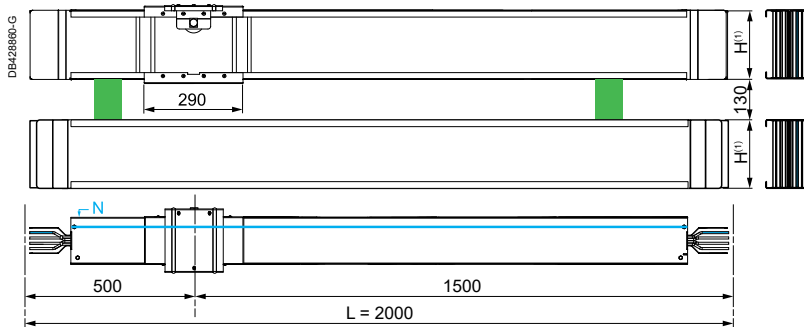

#### KTA5000EB●40

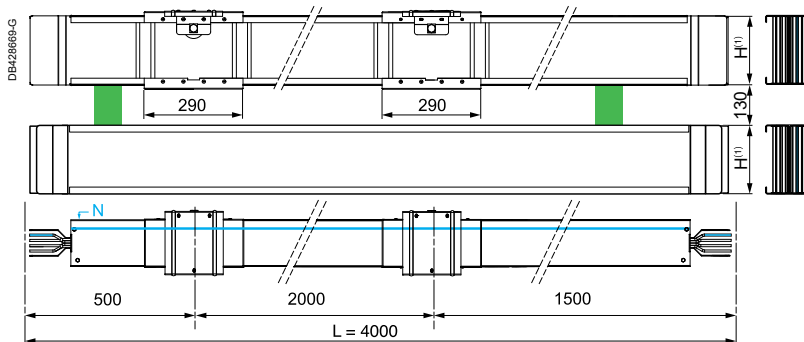

(1) See the "Trunking cross-section" table page 52.



# Additional run components IP55

## Canalis KTA 800 to 4000

A

B

C

D

E

F

G

### Ordering

Complete the catalogue number by replacing "●●●●" by the rating.

#### Important:

- for the 800 A rating, add a "0" in the catalogue number: **KTA0800**
- add the dimensions of the selected component as a technical comment.

**Example:** the catalogue number of a 1250 A neutral crossover length, 3L + N + PE, 1000 mm long, is:

**KTA1250TN410**

Rating

### DB - Straight expansion unit

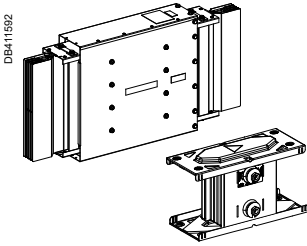

KTA●●●●DB●10

Type	Length "L" (mm)	Cat. no.		
		3L + PE	3L + N + PE <sup>(2)</sup>	3L + N + PER <sup>(1)</sup>
Fixed	1000	KTA●●●●DB310	KTA●●●●DB410	KTA●●●●DB510

(1) To order the 3L + N + PER version with reinforced Isc, replace KTA●●●●DB510 by KTA●●●●DB710.

(2) To order the 3L + N + PE 2500 A and 3200 A version with reinforced Isc, replace KTA2500DB4●● by KTA2500DB6●● and KTA3200DB4●● by KTA3200DB6●●.

KTA●●●●DB●10

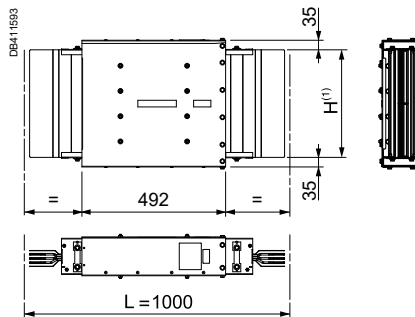

(1) See the "Trunking cross-section" page 58.

### TN - Neutral crossover length

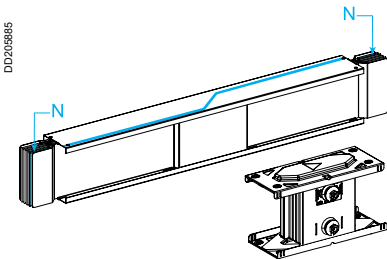

KTA●●●●TN●10

Type	Length "L" (mm)	Cat. no.
		3L + N + PE
Fixed	1000	KTA●●●●TN410
Fixed	1000	KTA●●●●TN610

KTA●●●●TN●10

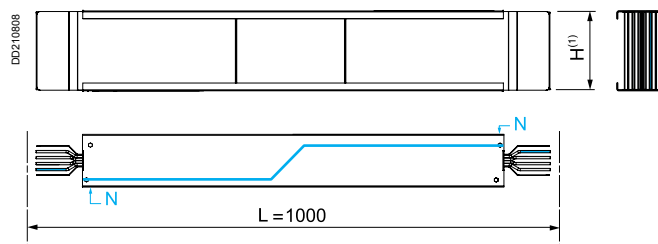

(1) See the "Trunking cross-section" page 58.

### TP - Phase crossover length

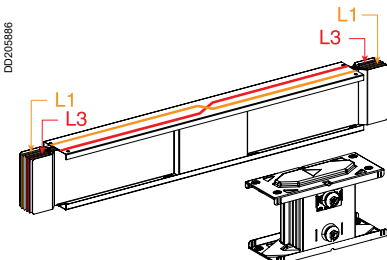

KTA●●●●TP●10

Type	Length "L" (mm)	Cat. no.
		3L + N + PE
Fixed	1000	KTA●●●●TP410
Fixed	1000	KTA●●●●TP610

KTA●●●●TP●10

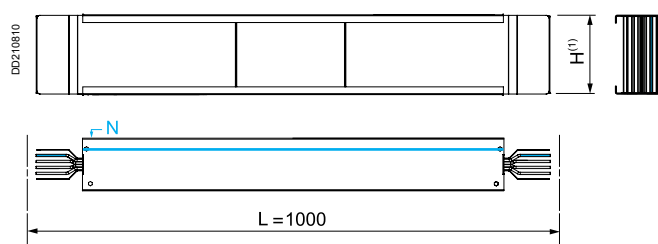

(1) See the "Trunking cross-section" page 58.

### Canalis KTA 5000

#### DB - Straight expansion unit

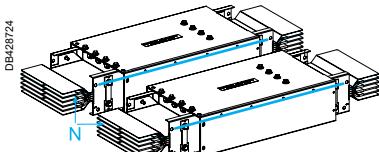

KTA5000DB10

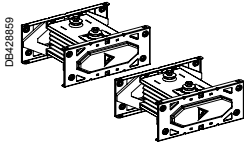

Type	Length "L" (mm)	Cat. no.		
		3L + PE	3L + N + PE	3L + N + PER <sup>(1)</sup>
Fixed	1000	KTA5000DB310	KTA5000DB410	KTA5000DB510

(1) To order the 3L + N + PER version with reinforced Isc, replace KTA5000DB510 by KTA5000DB710.

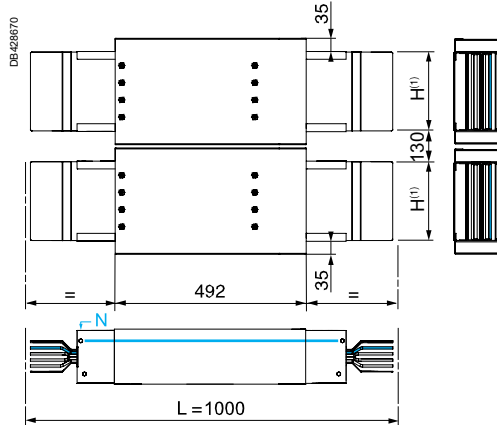

(1) See the "Trunking cross-section" page 58.

#### TN - Neutral crossover length

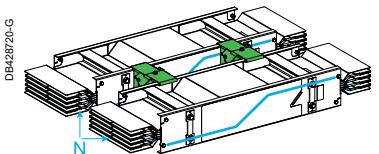

KTA5000TN410

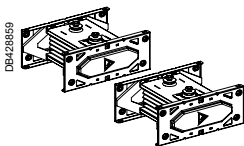

Type	Length "L" (mm)	Cat. no. <sup>(1)</sup>
		3L + N + PE
Fixed	1000	KTA5000TN410

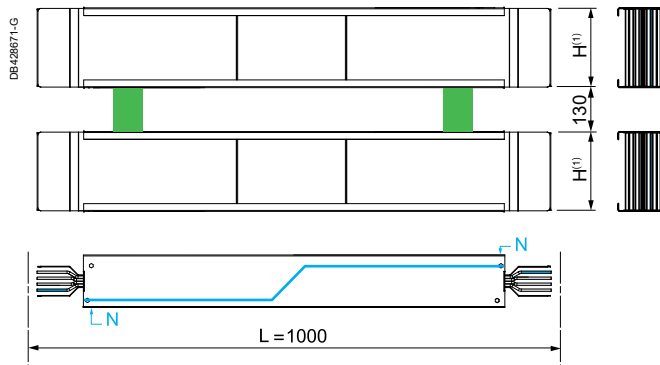

(1) See the "Trunking cross-section" page 58.

#### TP - Phase crossover length

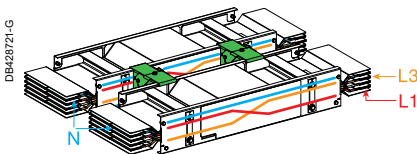

KTA5000TP410

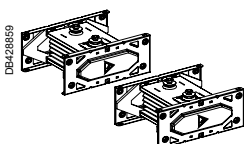

Type	Length "L" (mm)	Cat. no. <sup>(1)</sup>
		3L + N + PE
Fixed	1000	KTA5000TP410

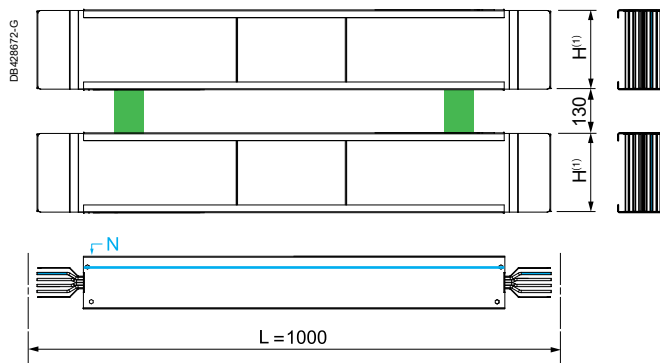

(1) See the "Trunking cross-section" page 58.

# Catalogue numbers and dimensions

## Additional run components

### IP55

#### Canalis KTA 800 to 5000

#### YA - Additional jointing units

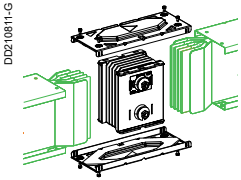

DDZ10811-G

KTA●●●YA●

Type	Cat. no. <sup>(2)</sup>			
	3L + PE	3L + N + PE	3L + N + PER	
Version code <sup>(1)</sup>	3	4 or 6	5	7
Jointing unit <sup>(3)</sup>	KTA●●●YA3	KTA●●●YA●	KTA●●●YA5	KTA●●●YA7

(1) See catalogue-number coding page 48.

(2) References KTA5000YA● are made of 2 references KTA2500YA●.

(3) YA is not applicable for Fire rated busway elements. refer page 71 for fire rated jointing units.

KTA●●●YA●

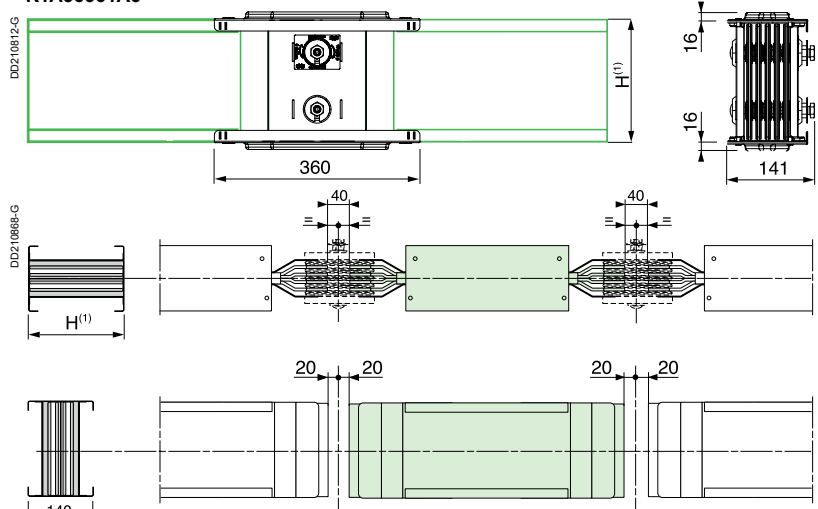

(1) See the "Trunking cross-section" table below.

#### FA - End covers

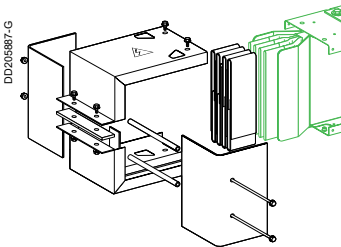

DDZ09887-G

KTB0●●●FA

Type	Rating of the trunking (A)	Height H of the trunking (mm)	Cat. no.
End cover	800	74	KTB0074FA
	1000	104	KTB0104FA
	1250	124	KTB0124FA
	1600	164	KTB0164FA
	2000	204	KTB0204FA
	2500	244	KTB0244FA
	3200	324	KTB0324FA
	4000	404	KTB0404FA
	5000 <sup>(1)(2)</sup>	622	KTB0622FA

KTB0●●●FA

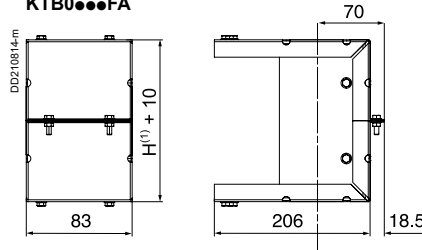

(1) See the "Trunking cross-section" table below.

(2) The reference KTB0622FA is made of 2 references KTB0244FA.

#### Trunking cross-section

Rating (A)	800 <sup>(1)</sup>	1000	1250	1600	2000	2500	3200	4000	5000
Weight (kg/m)									
	3L + PE	12	14	16	19	22	25	31	50
	3L + N + PE	13	16	18	22	26	30	37	60
	3L + N + PER	15	19	21	26	31	36	46	72
Height H (mm)									
Width W (mm)									
		140	140	140	140	140	140	140	140
		74	104	124	164	204	244	324	404
									244
									130
									244

DDZ10887

DB411584

(1) Important: for the 800 A rating, indicate "KTA0800".

### Canalis KTA 5000

#### GS - Guide support

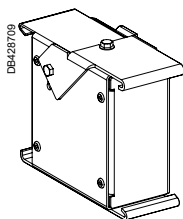

KTA5000GS1

2 guide supports<sup>(1)</sup> are required to linked all KTA2500 elements together in order to create the KTA5000 run.

(1) 3 guide supports are required for 4 m straight length, 1 for straight end feed units ER1. These guide supports carry the label KTA5000 A.

Description	Cat. no.	Weight (kg)
1 guide support	KTA5000GS1	0.6

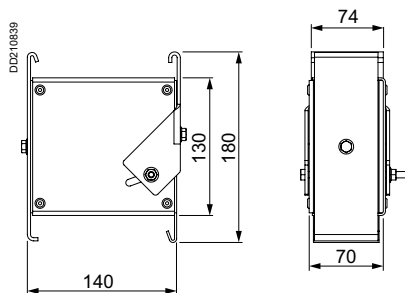

#### HC - Edgewise H

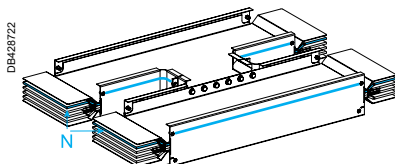

KTA5000HC10

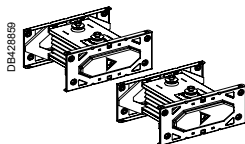

Type	Length "L" (mm)	Cat. no.
		3L + PE      3L + N + PE      3L + N + PER <sup>(1)</sup>
Fixed	1000	KTA5000HC310    KTA5000HC410    KTA5000HC510

(1) To order the 3L + N + PER version with reinforced lsc, replace KTA5000HC510 by KTA5000HC710.

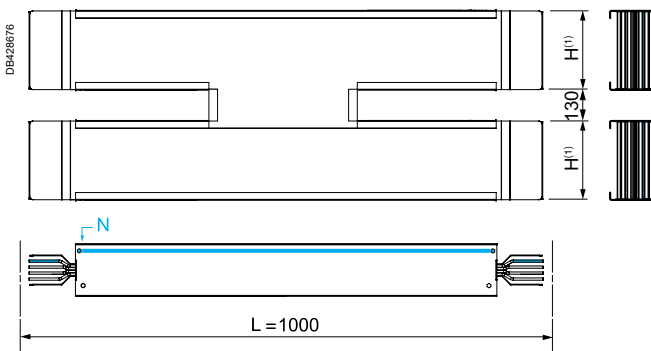

(1) See the "Trunking cross-section" page 58.



# Elbow components for changing direction IP55

## Canalis KTA 800 to 5000

### Ordering

Complete the catalogue number by replacing "●●●●" by the rating.

**Important:**

- for the 800 A rating, add a "0" in the catalogue number: **KTA0800**
- add the dimensions of the selected component as a technical comment.

**Example:** the catalogue number of a 2000 A flat elbow, N1, 3L + N + PE with dimensions A = 300 mm and B = 650 mm is:

**KTA2000LP4B1, A = 300, B = 650.**



### LP - Flat elbows

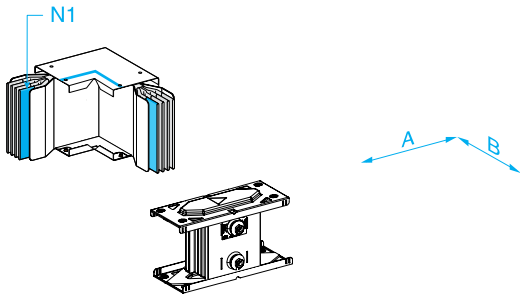

KTA●●●●LP●●1

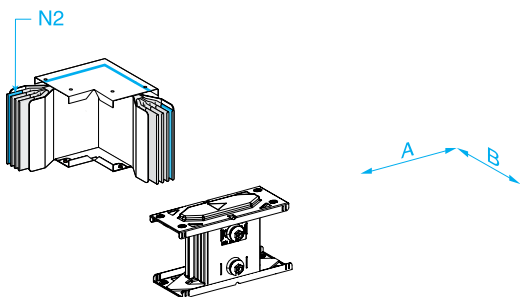

KTA●●●●LP●●2

Type	Position of neutral	Cat. no.		
		3L + PE	3L + N + PE <sup>(2)</sup>	3L + N + PER <sup>(1)</sup>
2 fixed branches	N1	KTA●●●●LP3A1	KTA●●●●LP4A1	KTA●●●●LP5A1
	N2	KTA●●●●LP3A2	KTA●●●●LP4A2	KTA●●●●LP5A2
1 made to measure short branche	N1	KTA●●●●LP3B1	KTA●●●●LP4B1	KTA●●●●LP5B1
	N2	KTA●●●●LP3B2	KTA●●●●LP4B2	KTA●●●●LP5B2
1 made to measure long branche	N1	KTA●●●●LP3D1	KTA●●●●LP4D1	KTA●●●●LP5D1
	N2	KTA●●●●LP3D2	KTA●●●●LP4D2	KTA●●●●LP5D2
2 made to measure branches	N1	KTA●●●●LP3E1	KTA●●●●LP4E1	KTA●●●●LP5E1
	N2	KTA●●●●LP3E2	KTA●●●●LP4E2	KTA●●●●LP5E2

(1) To order the 3L + N + PER version with reinforced Isc, replace KTA●●●●LP5●● by KTA●●●●LP7●●.

(2) To order the 3L + N + PE 2500 A and 3200 A version with reinforced Isc, replace KTA2500LP4●● by KTA2500LP6●● and KTA3200LP4●● by KTA3200LP6●●.

### KTA●●●●LP●●●●

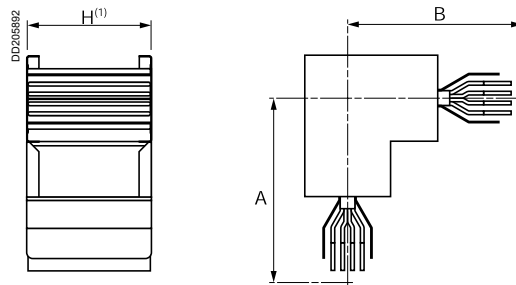

(1) See the "Trunking cross-section" table page 65.

### Dimensions

Type	Rating (A)	Dimensions (mm)	
		A	B
2 fixed branches	800, 1000, 1250	300	300
	1600, 2000, 2500		
	3200, 4000, 5000		
1 made to measure short branche	800, 1000, 1250	300	301 to 799
	1600, 2000, 2500	301 to 799	300
	3200, 4000, 5000		
1 made to measure long branche	800, 1000, 1250	300	800 to 1000
		800 to 1000	300
	1600, 2000, 2500,	300	800 to 1100
		5000	800 to 1100
	3200, 4000	300	800 to 1400
		800 to 1400	300
2 made to measure branches	800, 1000, 1250	301 to 600	301 to 1000
		301 to 1000	301 to 600
	1600, 2000, 2500,	301 to 600	301 to 1100
		5000	301 to 1100
	3200, 4000	301 to 600	301 to 1400
		301 to 1400	301 to 600
5000	301 to 600	301 to 1100	
	301 to 1100	301 to 600	

# Catalogue numbers and dimensions

## Elbow components for changing direction

### IP55

### Canalis KTA 800 to 4000

#### LP.C - Flat elbows with made to measure angles

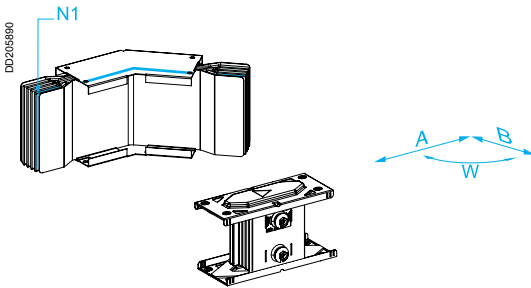

KTA●●●●LP●C1

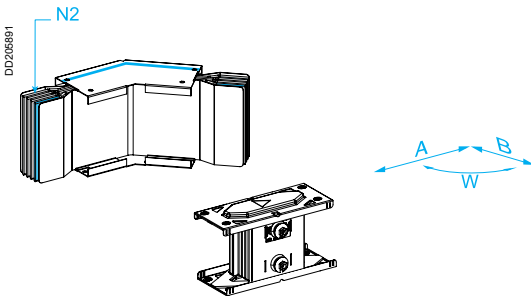

KTA●●●●LP●C2

Type	Position of neutral	Cat. no.		
		3L + PE	3L + N + PE <sup>(2)</sup>	3L + N + PER <sup>(1)</sup>
Made to measure angle	N1	KTA●●●●LP3C1	KTA●●●●LP4C1	KTA●●●●LP5C1
	N2	KTA●●●●LP3C2	KTA●●●●LP4C2	KTA●●●●LP5C2

(1) To order the 3L + N + PER version with reinforced Isc, replace KTA●●●●LP5C● by KTA●●●●LP7C●.

(2) To order the 3L + N + PE 2500 A and 3200 A version with reinforced Isc, replace KTA2500LP4●● by KTA2500LP6●● and KTA3200LP4●● by KTA3200LP6●●.

KTA●●●●LP●C●

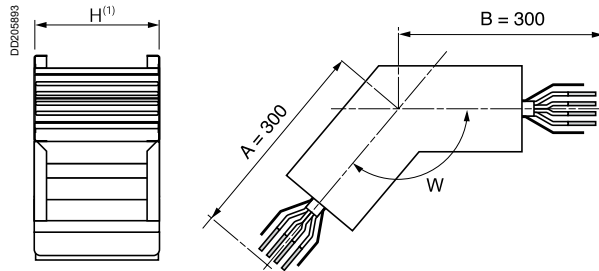

(1) See the "Trunking cross-section" table page 65.

#### Dimensions

Type	Rating (A)	Dimensions (mm)		
		A	B	W
Made to measure	All	300	300	91° to 179°

#### LC - Edgewise elbows

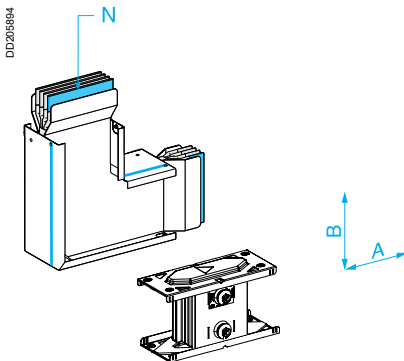

KTA●●●●LC●●

Type	Cat. no.		
	3L + PE	3L + N + PE <sup>(2)</sup>	3L + N + PER <sup>(1)</sup>
2 fixed branches	KTA●●●●LC3A	KTA●●●●LC4A	KTA●●●●LC5A
1 made to measure short branche	KTA●●●●LC3B	KTA●●●●LC4B	KTA●●●●LC5B
1 made to measure long branche	KTA●●●●LC3D	KTA●●●●LC4D	KTA●●●●LC5D
2 made to measure branches	KTA●●●●LC3E	KTA●●●●LC4E	KTA●●●●LC5E

(1) To order the 3L + N + PER version with reinforced Isc, replace KTA●●●●LC5● by KTA●●●●LC7●.

(2) To order the 3L + N + PE 2500 A and 3200 A version with reinforced Isc, replace KTA2500LC4● by KTA2500LC6● and KTA3200LC4● by KTA3200LC6●.

KTA●●●●LC●●

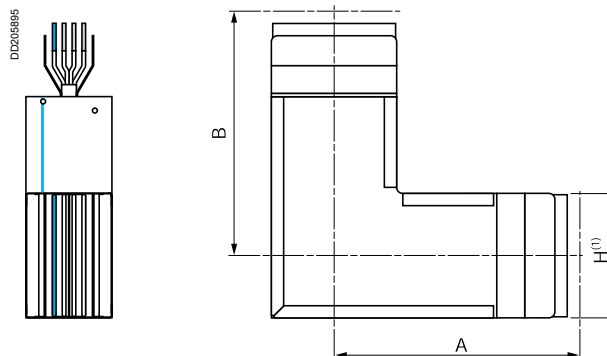

(1) See the "Trunking cross-section" table page 65 and dimensions page 64.

# Elbow components for changing direction IP55

## Canalis KTA 5000

### LP - Elbows

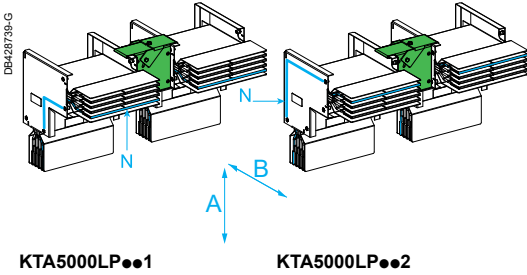

KTA5000LP●●1

KTA5000LP●●2

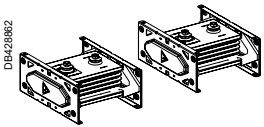

Type	Position of neutral	Cat. no.		
		3L + PE	3L + N + PE	3L + N + PER <sup>(1)</sup>
2 fixed branches	N1	KTA5000LP3A1	KTA5000LP4A1	KTA5000LP5A1
	N2	KTA5000LP3A2	KTA5000LP4A2	KTA5000LP5A2
1 made to measure short branch	N1	KTA5000LP3B1	KTA5000LP4B1	KTA5000LP5B1
	N2	KTA5000LP3B2	KTA5000LP4B2	KTA5000LP5B2
1 made to measure long branch	N1	KTA5000LP3D1	KTA5000LP4D1	KTA5000LP5D1
	N2	KTA5000LP3D2	KTA5000LP4D2	KTA5000LP5D2
2 made to measure branches	N1	KTA5000LP3E1	KTA5000LP4E1	KTA5000LP5E1
	N2	KTA5000LP3E2	KTA5000LP4E2	KTA5000LP5E2

(1) To order the 3L + N + PER version with reinforced Isc, replace KTA5000LP5●● by KTA5000LP7●●.

#### 2 x KTA2500LP●●●

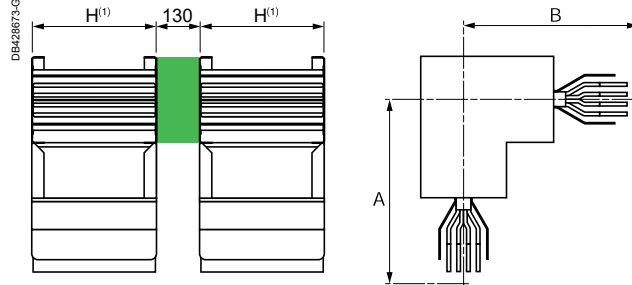

(1) See the "Trunking cross-section" table page 65 and dimensions page 60.

### LP●C - Flat elbows with made to measure angles

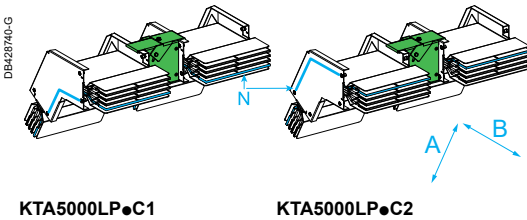

KTA5000LP●C1

KTA5000LP●C2

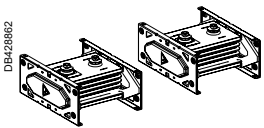

Type	Position of neutral	Cat. no. <sup>(2)</sup>		
		3L + PE	3L + N + PE	3L + N + PER <sup>(1)</sup>
Made to measure angle	N1	KTA5000LP3C1	KTA5000LP4C1	KTA5000LP5C1
	N2	KTA5000LP3C2	KTA5000LP4C2	KTA5000LP5C2

(1) To order the 3L + N + PER version with reinforced Isc, replace KTA5000LP5●● by KTA5000LP7C●.

#### 2 x KTA2500LP●●●

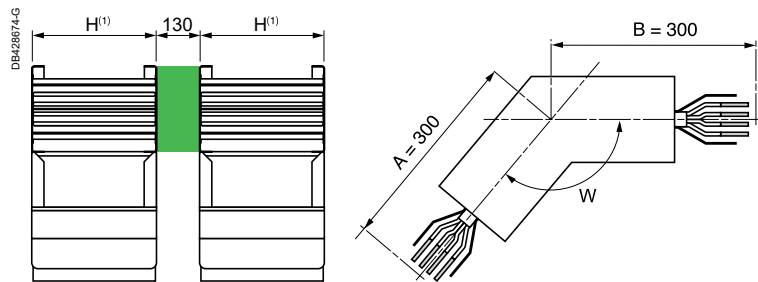

(1) See the "Trunking cross-section" table page 65.

#### Dimensions

Rating (A)	Dimensions (mm)		
	A	B	W
5000	300	300	91° to 179°

# Catalogue numbers and dimensions

## Elbow components for changing direction

### IP55

### Canalis KTA 5000

#### LC - Edgewise elbows

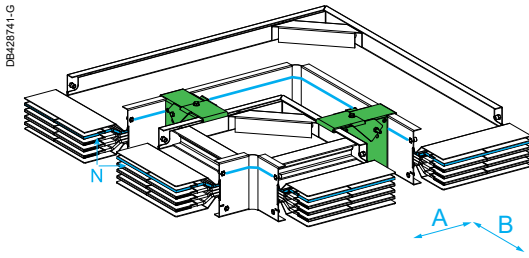

KTA5000LC●●●

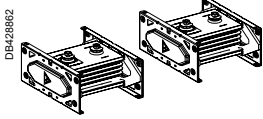

Type	Cat. no. <sup>(2)</sup>		
	3L + PE	3L + N + PE	3L + N + PER <sup>(1)</sup>
2 fixed branches	KTA5000LC3A	KTA5000LC4A	KTA5000LC5A
1 made to measure short branche	KTA5000LC3B	KTA5000LC4B	KTA5000LC5B

(1) To order the 3L + N + PER version with reinforced lsc, replace KTA5000LC5● by KTA5000LC7●.

2 x KTA2500LC●●●

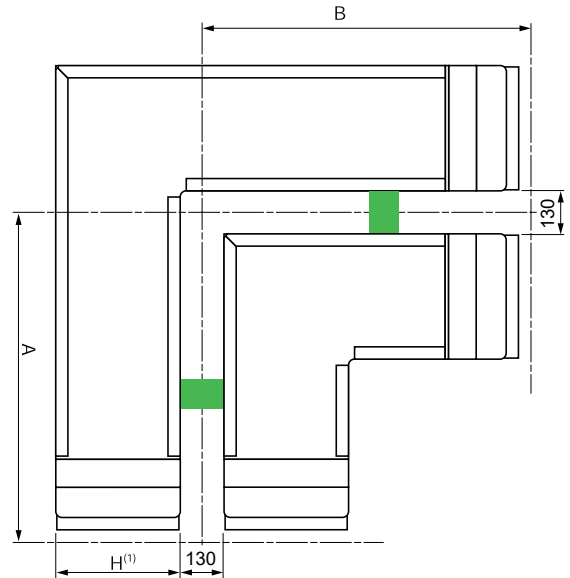

(1) See the "Trunking cross-section" table page 65 and dimensions page 64.



# Elbow components for changing direction

## IP55

### Canalis KTA 800 to 5000

A

B

C

D

E

F

G

#### Dimensions

Type	Rating (A)	Dimensions (mm)	
		A	B
2 fixed branches	800 <sup>(1)</sup>	275	275
	1000	290	290
	1250	300	300
	1600	320	320
	2000	340	340
	2500	360	360
	3200	400	400
	4000	440	440
	5000	548	548
1 made to measure short branche	800 <sup>(1)</sup>	275	276 to 774
		276 to 774	275
	1000	290	291 to 789
		291 to 789	290
	1250	300	301 to 799
		301 to 799	300
	1600	320	321 to 819
		321 to 819	320
	2000	340	341 to 839
		341 to 839	340
	2500	360	361 to 859
		361 to 859	360
	3200	400	401 to 899
		401 to 899	400
	4000	440	441 to 939
	441 to 939	440	
1 made to measure long branche	800 <sup>(1)</sup>	275	775 to 1000
		775 to 1000	275
	1000	290	790 to 1000
		790 to 1000	290
	1250	300	800 to 1000
		800 to 1000	300
	1600	320	820 to 1100
		820 to 1100	320
	2000	340	840 to 1100
		840 to 1100	340
	2500	360	860 to 1100
		860 to 1100	360
	3200	400	900 to 1400
		900 to 1400	400
	2 made to measure branches	800 <sup>(1)</sup>	276 to 745
		276 to 1000	276 to 745
1000		291 to 730	291 to 1000
		291 to 1000	291 to 730
1250		301 to 720	301 to 1000
		301 to 1000	301 to 720
1600		321 to 700	321 to 1100
		321 to 1100	321 to 700
2000		341 to 680	341 to 1100
		341 to 1100	341 to 680
2500		361 to 660	361 to 1100
		361 to 1100	361 to 660
3200		401 to 620	401 to 1400
		401 to 1400	401 to 620
4000		441 to 580	441 to 1400
	441 to 1400	441 to 580	

(1) For the 800 A rating, indicate "KTA0800".

# Catalogue numbers and dimensions

## Elbow components for changing direction

### IP55

### Canalis KTA 800 to 4000

#### TC - Edgewise tee

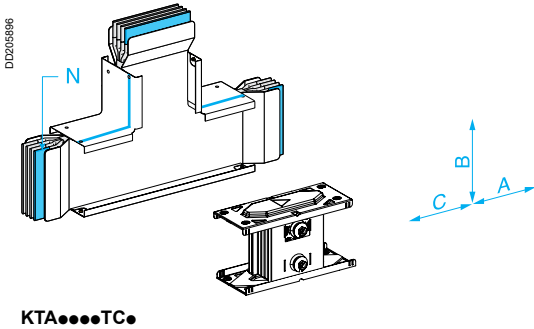

Type	Cat. no. <sup>(3)</sup>		
	3L + PE	3L + N + PE <sup>(2)</sup>	3L + N + PER <sup>(1)</sup>
Fixed	KTA●●●●TC3	KTA●●●●TC4	KTA●●●●TC5

- (1) To order the 3L + N + PER version with reinforced Isc, replace KTA●●●●TC5 by KTA●●●●TC7.
- (2) To order the 3L + N + PE 2500 A and 3200 A version with reinforced Isc, replace KTA2500TC4 by KTA2500TC6 and KTA3200TC4 by KTA3200TC6.
- (3) Not available for KTA5000.

#### KTA●●●●TC●

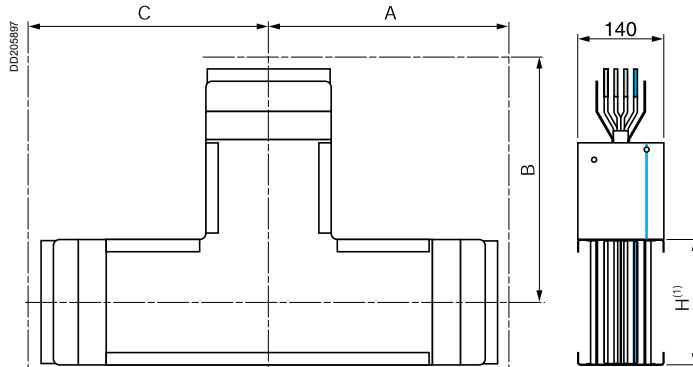

(1) See the "Trunking cross-section" table below.

#### Dimensions

Type	Rating (A)	Dimensions (mm)		
		A	B	C
Fixed	800 <sup>(2)</sup>	275	275	275
	1000	290	290	290
	1250	300	300	300
	1600	320	320	320
	2000	340	340	340
	2500	360	360	360
	3200	400	400	400
	4000	440	440	440

(2) For the 800 A rating, indicate "KTA0800".

#### Trunking cross-section

Rating (A)	800 <sup>(1)</sup>	1000	1250	1600	2000	2500	3200	4000	5000
Weight (kg/m)									
3L + PE	12	14	16	19	22	25	31	38	50
3L + N + PE	13	16	18	22	26	30	37	45	60
3L + N + PER	15	19	21	26	31	36	46	56	72

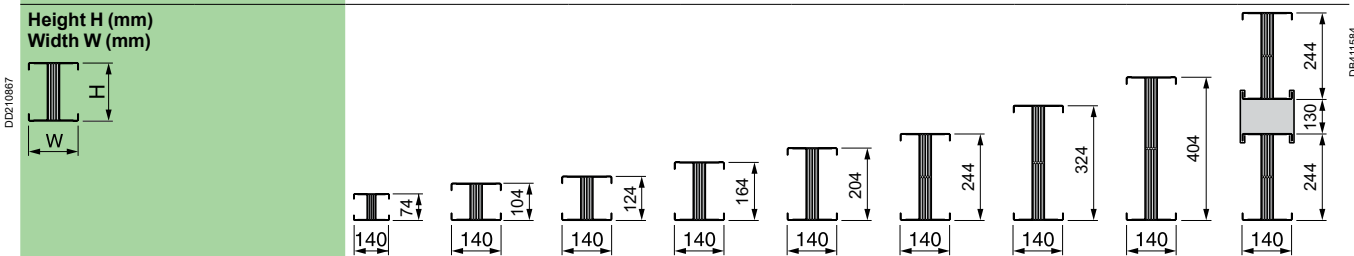

(1) Important: for the 800 A rating, indicate "KTA0800".

# Zed components for changing direction

## IP55

### Canalis KTA 800 to 4000

A

B

C

D

E

F

G

### Ordering

Complete the catalogue number by replacing "●●●●" by the rating.

#### Important:

- for the 800 A rating, add a "0" in the catalogue number: **KTA0800**
- add the dimensions of the selected component as a technical comment.

**Example:** the catalogue number of a 1600 A edgewise zed unit, N2, 3L + N + PE with dimensions A = 300 mm, B = 450 mm, C = 300 mm is:  
**KTA1600ZC42, A = 300, B = 450, C = 300.**

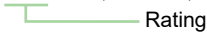

### ZP - Flat zed units

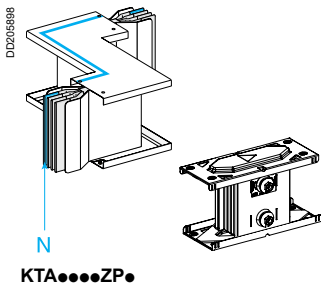

Type	Cat. no. <sup>(3)</sup>		
	3L + PE	3L + N + PE <sup>(2)</sup>	3L + N + PER <sup>(1)</sup>
Made to measure	KTA●●●●ZP3	KTA●●●●ZP4	KTA●●●●ZP5

- (1) To order the 3L + N + PER version with reinforced Isc, replace KTA●●●●ZP5 by KTA●●●●ZP7.  
 (2) To order the 3L + N + PE 2500 A and 3200 A version with reinforced Isc, replace KTA2500ZP4 by KTA2500ZP6 and KTA3200ZP4 by KTA3200ZP6.  
 (3) References KTA5000ZP● are made of 2 references KTA2500ZP●. See details page 67.

#### KTA●●●●ZP●

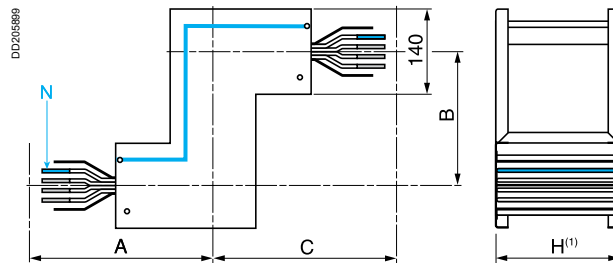

(1) See the "Trunking cross-section" page 68.

#### Dimensions

Rating (A)	Dimensions (mm)		
	A	B	C
All	300	130 to 599	300

### ZC - Edgewise zed units

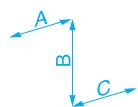
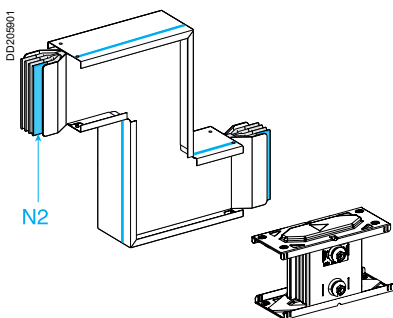
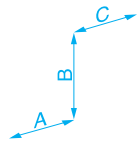
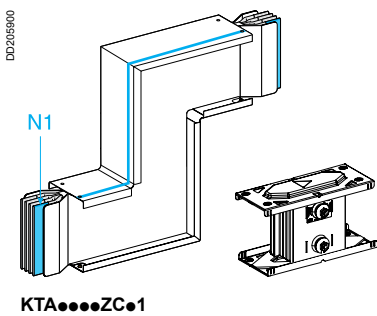

Type	Position of neutral	Cat. no.		
		3L + PE	3L + N + PE <sup>(2)</sup>	3L + N + PER <sup>(1)</sup>
Made to measure	N1	KTA●●●●ZC31	KTA●●●●ZC41	KTA●●●●ZC51
	N2	KTA●●●●ZC32	KTA●●●●ZC42	KTA●●●●ZC52

- (1) To order the 3L + N + PER version with reinforced Isc, replace KTA●●●●ZC5● by KTA●●●●ZC7●.  
 (2) To order the 3L + N + PE 2500 A and 3200 A version with reinforced Isc, replace KTA2500ZC4● by KTA2500ZC6● and KTA3200ZC4● by KTA3200ZC6●.

#### KTA●●●●ZC●●

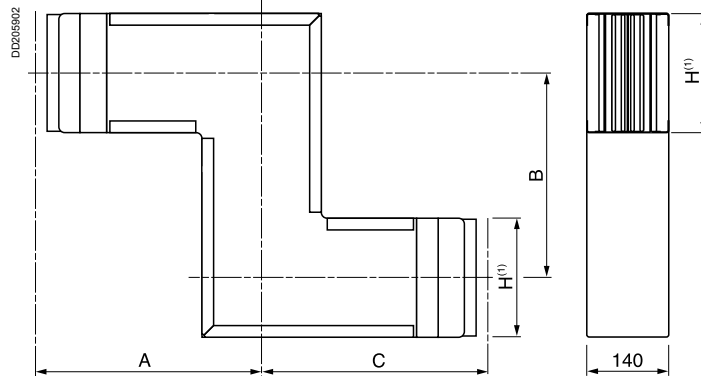

#### Dimensions

Rating (A)	Dimensions (mm)		
	A	B	C
800 <sup>(2)</sup>	275	90 to 549	275
1000	290	90 to 579	290
1250	300	90 to 599	300
1600	320	90 to 639	320
2000	340	90 to 679	340
2500	360	90 to 719	360
3200	400	90 to 799	400
4000	440	90 to 879	440

(1) See the "Trunking cross-section" page 68.  
 (2) For the 800 A rating, indicate "KTA0800".

# Catalogue numbers and dimensions

## Zed components for changing direction

### IP55

### Canalis KTA 5000

#### ZP - Flat zed units

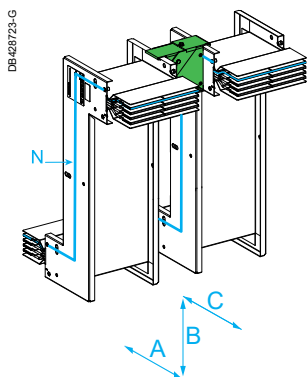

KTA5000ZP●

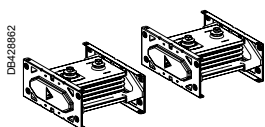

Type	Cat. no.		
	3L + PE	3L + N + PE	3L + N + PER <sup>(1)</sup>
Made to measure	KTA5000ZP3	KTA5000ZP4	KTA5000ZP5

(1) To order the 3L + N + PER version with reinforced lsc, replace KTA5000ZP5 by KTA5000ZP7.

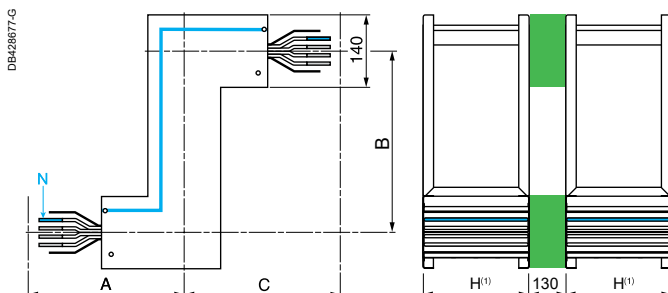

(1) See the "Trunking cross-section" page 68.

Dimensions Rating (A)	Dimensions (mm)		
	A	B	C
5000	300	130 to 599	300

#### ZC - Edgewise zed units

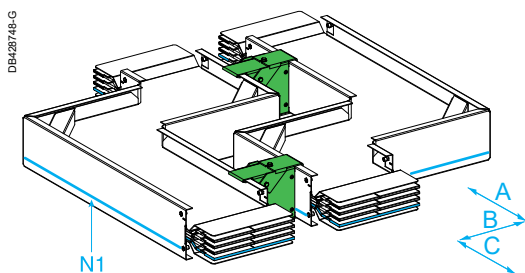

KTA5000ZC1●

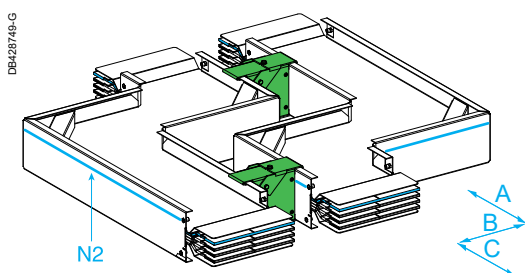

KTA5000ZC2●

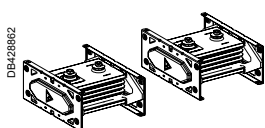

Type	Position of neutral	Cat. no. <sup>(2)</sup>		
		3L + PE	3L + N + PE	3L + N + PER <sup>(1)</sup>
Made to measure	N1	KTA5000ZC31	KTA5000ZC41	KTA5000ZC51
	N2	KTA5000ZC32	KTA5000ZC42	KTA5000ZC52

(1) To order the 3L + N + PER version with reinforced lsc, replace KTA5000ZC5● by KTA5000ZC7●.

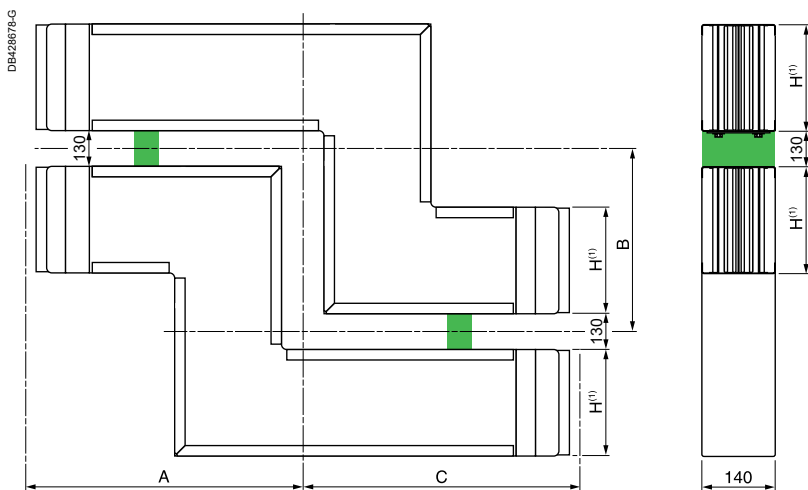

(1) See the "Trunking cross-section" page 68.

Dimensions Rating (A)	Dimensions (mm)		
	A	B	C
5000	548	90 to 719	548

# Zed components for changing direction IP55

## Canalis KTA 800 to 4000

### CP - Edgewise and flat zed units

A  
B  
C  
D  
E  
F  
G

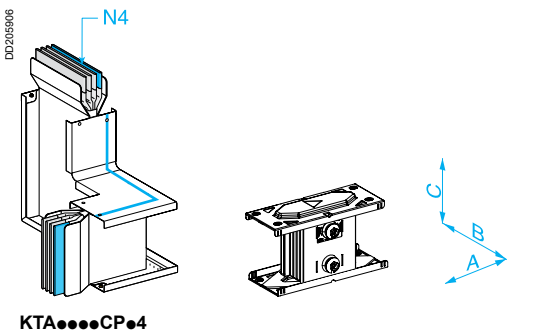
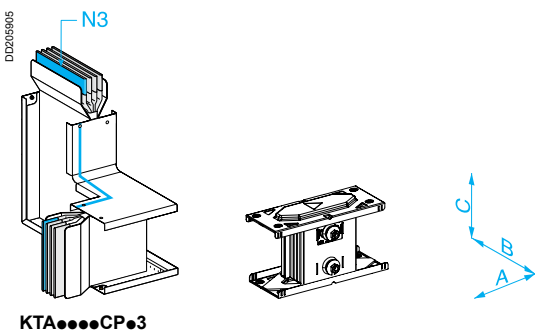
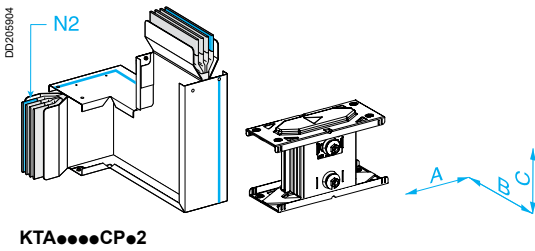
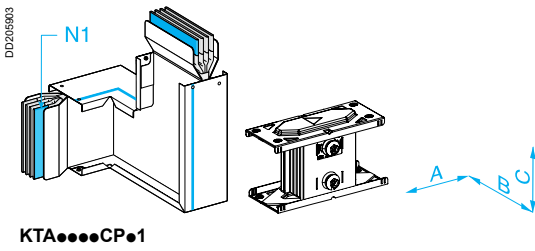

Type	Position of neutral	Cat. no.		
		3L + PE	3L + N + PE <sup>(2)</sup>	3L + N + PER <sup>(1)</sup>
Made to measure	N1	KTA●●●●CP31	KTA●●●●CP41	KTA●●●●CP51
	N2	KTA●●●●CP32	KTA●●●●CP42	KTA●●●●CP52
	N3	KTA●●●●CP33	KTA●●●●CP43	KTA●●●●CP53
	N4	KTA●●●●CP34	KTA●●●●CP44	KTA●●●●CP54

(1) To order the 3L + N + PER version with reinforced Isc, replace KTA●●●●CP5● by KTA●●●●CP7●.  
 (2) To order the 3L + N + PE 2500 A and 3200 A version with reinforced Isc, replace KTA2500CP4● by KTA2500CP6● and KTA3200CP4● by KTA3200CP6●.

#### KTA●●●●CP1 and KTA●●●●CP2

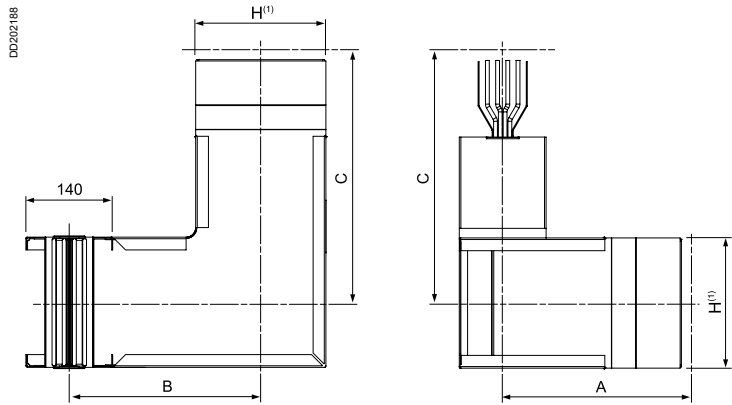

#### KTA●●●●CP3 and KTA●●●●CP4

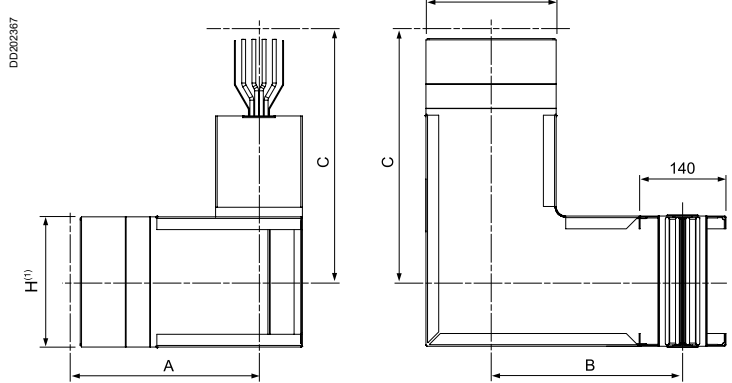

#### Dimensions

Rating (A)	Dimensions (mm)		
	A	B	C
800 <sup>(2)</sup>	300	195 to 574	275
1000	300	210 to 589	290
1250	300	220 to 599	300
1600	300	240 to 619	320
2000	300	260 to 639	340
2500	300	280 to 659	360
3200	300	320 to 699	400
4000	300	360 to 739	440

(1) See the "Trunking cross-section" table below.  
 (2) For the 800 A rating, indicate "KTA0800".

### Trunking cross-section

Rating (A)	800 <sup>(1)</sup>	1000	1250	1600	2000	2500	3200	4000	5000
Weight (kg/m)									
3L + PE	12	14	16	19	22	25	31	38	50
3L + N + PE	13	16	18	22	26	30	37	45	60
3L + N + PER	15	19	21	26	31	36	46	56	72

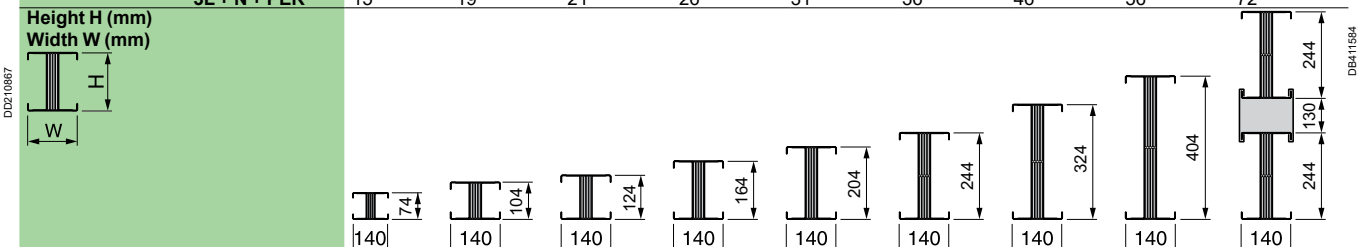

(1) Important: for the 800 A rating, indicate "KTA0800".

# Catalogue numbers and dimensions

## Zed components for changing direction

### IP55

### Canalis KTA 5000

#### CP - Edgewise and flat zed units

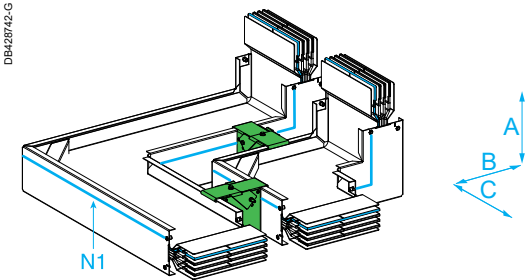

**KTA5000CPe1**

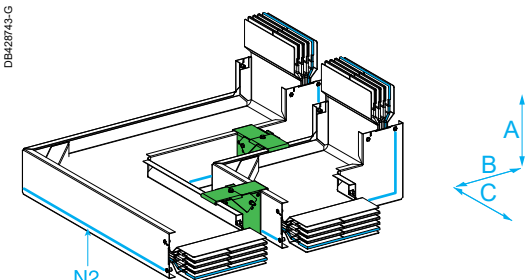

**KTA5000CPe2**

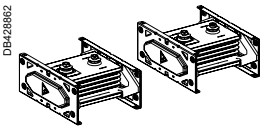

(1) See the "Trunking cross-section" page 68.

#### Dimensions

Rating (A)	Dimensions (mm)		
	A	B	C
5000	300	468 to 847	548

Type	Position of neutral	Cat. no. <sup>(2)</sup>		
		3L + PE	3L + N + PE	3L + N + PER <sup>(1)</sup>
Made to measure	N1	KTA5000CP31	KTA5000CP41	KTA5000CP51
	N2	KTA5000CP32	KTA5000CP42	KTA5000CP52
	N3	KTA5000CP33	KTA5000CP43	KTA5000CP53
	N4	KTA5000CP34	KTA5000CP44	KTA5000CP54

(1) To order the 3L + N + PER version with reinforced Isc, replace KTA5000CP5● by KTA5000CP7●.

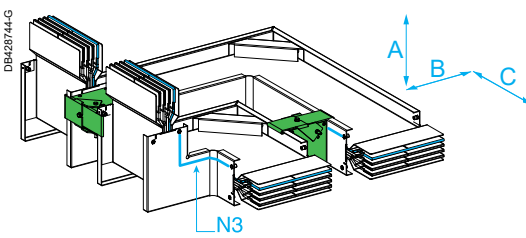
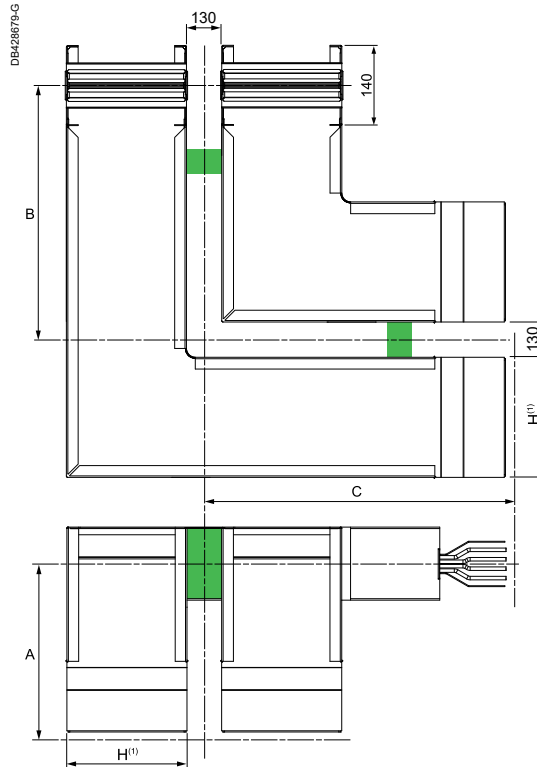

**KTA5000CPe3**

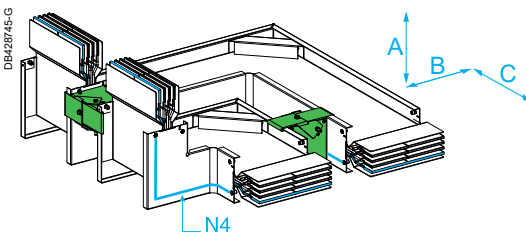

**KTA5000CPe4**

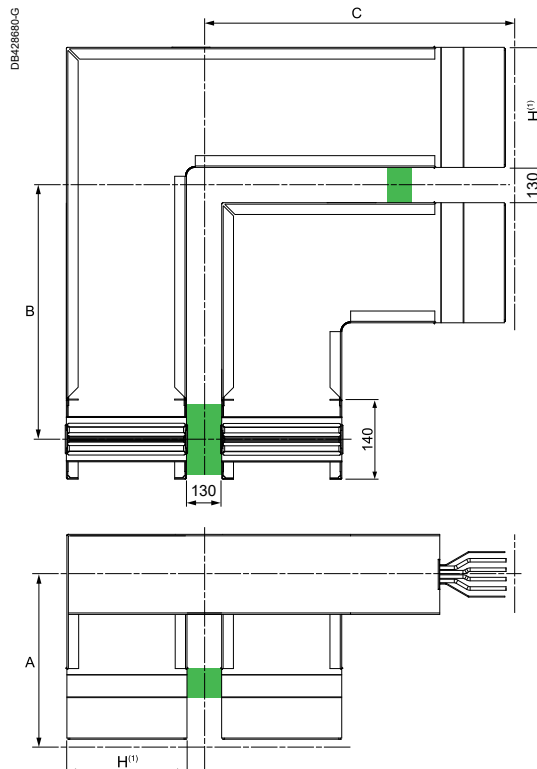
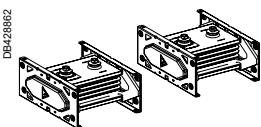

# Catalogue numbers and dimensions

## Fire rated straight feeder lengths

IP55

Compliant with the IEC 60331

Canalis KTA 800 to 4000

### Ordering

Complete the catalogue number by replacing "●●●●" by the rating.

#### Important:

■ for the 800 A rating, add a "0" in the catalogue number: **KTA0800**

■ add the dimensions of the selected component as a technical comment.

**Example:** the catalogue number of an 800 A feeder length, 3L + N + PE, 2450 mm long, is:

**KTA0800FT42C, L = 2450**

Rating

### FT - Fire rated straight feeder lengths

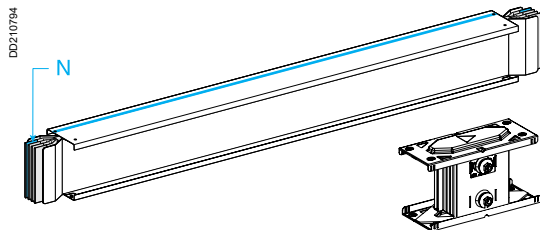

KTA●●●●FT●●●

Type	Length "L" (mm)	Cat. no.		
		3L + PE	3L + N + PE <sup>(2)</sup>	3L + N + PER <sup>(1)</sup>
Fixed	2000	KTA●●●●FT320	KTA●●●●FT420	KTA●●●●FT520
	4000	KTA●●●●FT340	KTA●●●●FT440	KTA●●●●FT540
Made to measure	500 to 1500	KTA●●●●FT31A	KTA●●●●FT41A	KTA●●●●FT51A
	1501 to 1999	KTA●●●●FT32B	KTA●●●●FT42B	KTA●●●●FT52B
	2001 to 2500	KTA●●●●FT32C	KTA●●●●FT42C	KTA●●●●FT52C
	2501 to 3000	KTA●●●●FT33D	KTA●●●●FT43D	KTA●●●●FT53D
	3001 to 3500	KTA●●●●FT33E	KTA●●●●FT43E	KTA●●●●FT53E
	3501 to 3999	KTA●●●●FT33F	KTA●●●●FT43F	KTA●●●●FT53F

(1) To order the 3L + N + PER version with reinforced lsc, replace KTA●●●●FT5●● by KTA●●●●FT7●●.

(2) To order the 3L + N + PE 2500 A and 3200 A version with reinforced lsc, replace KTA2500FT4●● by KTA2500FT6●● and KTA3200FT4●● by KTA3200FT6●●.

KTA●●●●FT●●●

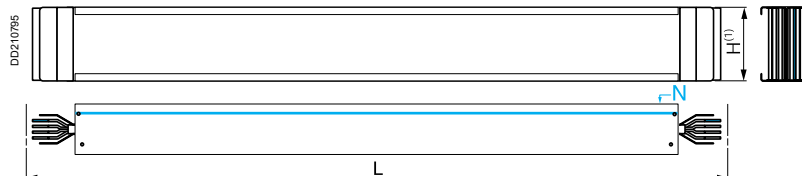

(1) See the "Trunking cross-section" table page 68.

### Canalis KTA 5000

### FT - Fire rated straight feeder lengths

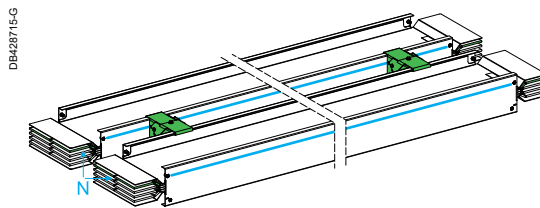

KTA5000FT●●●

Type	Length "L" (mm)	Cat. no.		
		3L + PE	3L + N + PE	3L + N + PER <sup>(1)</sup>
Fixed	2000	KTA5000FT320	KTA5000FT420	KTA5000FT520
	4000	KTA5000FT340	KTA5000FT440	KTA5000FT540
Made to measure	500 to 1500	KTA5000FT31A	KTA5000FT41A	KTA5000FT51A
	1501 to 1999	KTA5000FT32B	KTA5000FT42B	KTA5000FT52B
	2001 to 2500	KTA5000FT32C	KTA5000FT42C	KTA5000FT52C
	2501 to 3000	KTA5000FT33D	KTA5000FT43D	KTA5000FT53D
	3001 to 3500	KTA5000FT33E	KTA5000FT43E	KTA5000FT53E
	3501 to 3999	KTA5000FT33F	KTA5000FT43F	KTA5000FT53F

(1) To order the 3L + N + PER version with reinforced lsc, replace KTA5000FT5●● by KTA5000FT7●●.

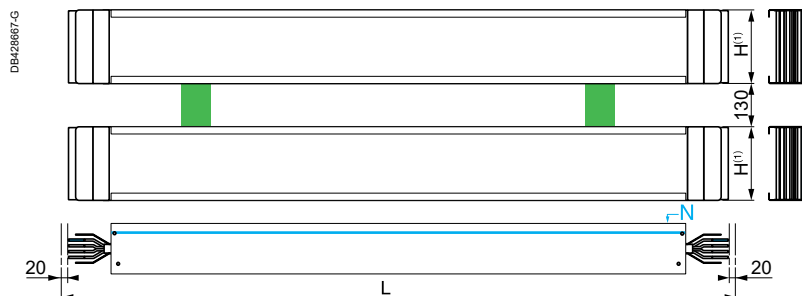
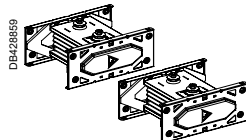

(1) See the "Trunking cross-section" table page 68.

# Catalogue numbers and dimensions

## Fire rated Jointing units

### IP55

Compliant with the IEC 60331

### FJ - Additional fire rated jointing units

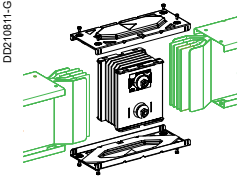

KTA●●●●FJ●

Type	Cat. no. <sup>(2)</sup>			
	3L + PE	3L + N + PE	3L + N + PER	
Version code <sup>(1)</sup>	3	4 or 6	5	7
Jointing unit	KTA●●●●FJ3	KTA●●●●FJ●	KTA●●●●FJ5	KTA●●●●FJ7

(1) See catalogue-number coding page 48.

(2) References KTA5000FJ● are made of 2 references KTA2500FJ●.

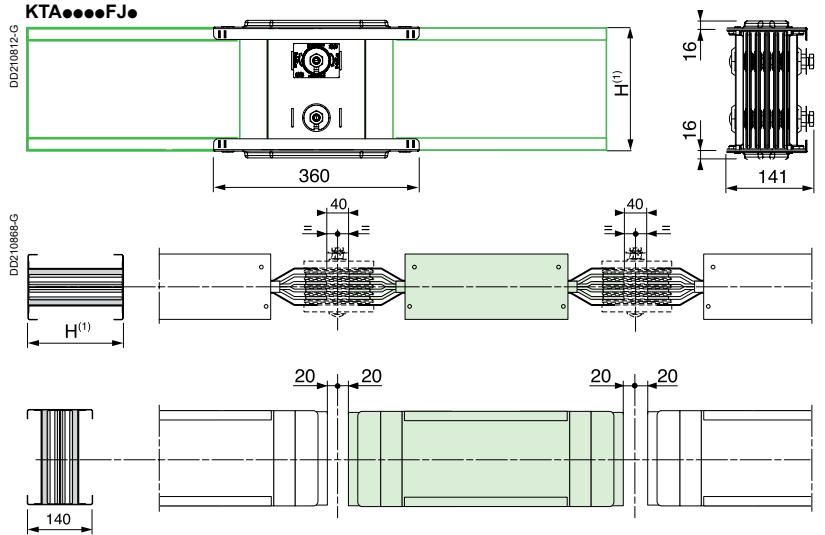

(1) See the "Trunking cross-section" table below.

### Trunking cross-section

Rating (A)	800 <sup>(1)</sup>	1000	1250	1600	2000	2500	3200	4000	5000
Weight (kg/m)									
3L + PE	12	14	16	19	22	25	31	38	50
3L + N + PE	13	16	18	22	26	30	37	45	60
3L + N + PER	15	19	21	26	31	36	46	56	72

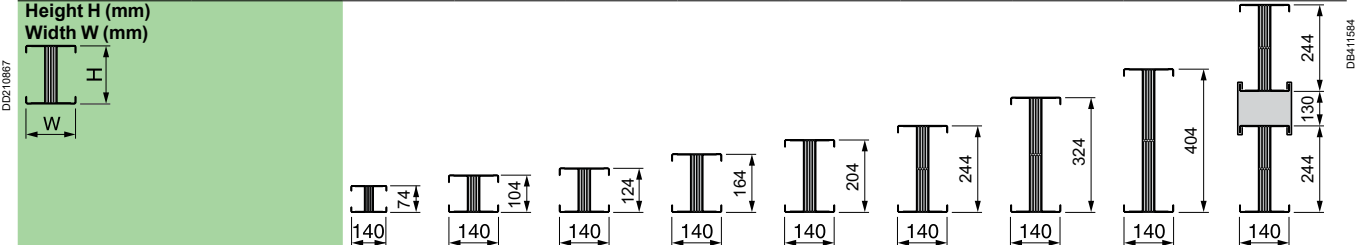

(1) Important: for the 800 A rating, indicate "KTA0800".

# Fire rated flat elbows

IP55

Compliant with the IEC 60331

Canalis KTA 800 to 4000

## Ordering

Complete the catalogue number by replacing "●●●●" by the rating.

### Important:

- for the 800 A rating, add a "0" in the catalogue number: **KTA0800**
- add the dimensions of the selected component as a technical comment.

**Example:** the catalogue number of a 2000 A flat elbow, N1, 3L + N + PE with dimensions A = 300 mm and B = 650 mm is:

**KTA2000FP4B1, A = 300, B = 650.**

Rating

## FP - Fire rated flat elbows

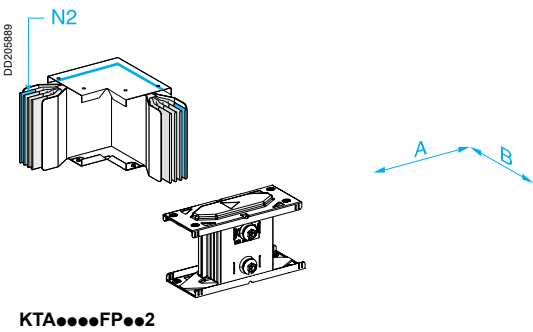
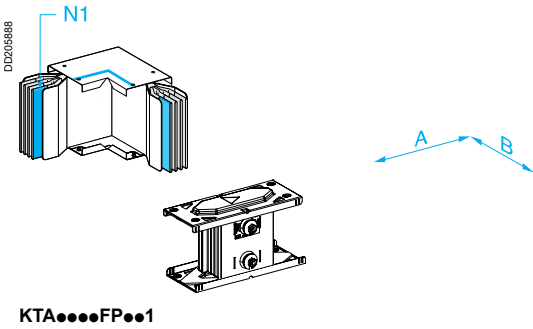

Type	Position of neutral	Cat. no.		
		3L + PE	3L + N + PE <sup>(2)</sup>	3L + N + PER <sup>(1)</sup>
2 fixed branches	N1	KTA...FP3A1	KTA...FP4A1	KTA...FP5A1
	N2	KTA...FP3A2	KTA...FP4A2	KTA...FP5A2
1 made to measure short branche	N1	KTA...FP3B1	KTA...FP4B1	KTA...FP5B1
	N2	KTA...FP3B2	KTA...FP4B2	KTA...FP5B2
1 made to measure long branche	N1	KTA...FP3D1	KTA...FP4D1	KTA...FP5D1
	N2	KTA...FP3D2	KTA...FP4D2	KTA...FP5D2
2 made to measure branches	N1	KTA...FP3E1	KTA...FP4E1	KTA...FP5E1
	N2	KTA...FP3E2	KTA...FP4E2	KTA...FP5E2

(1) To order the 3L + N + PER version with reinforced lsc, replace KTA...FP5... by KTA...FP7....

(2) To order the 3L + N + PE 2500 A and 3200 A version with reinforced lsc, replace KTA2500FP4... by KTA2500FP6... and KTA3200FP4... by KTA3200FP6....

KTA...FP...●●●

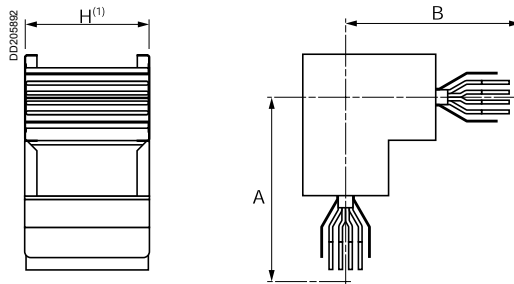

(1) See the "Trunking cross-section" table page 68 and dimensions page 64.

## Canalis KTA 5000

## FP - Fire rated flat elbows

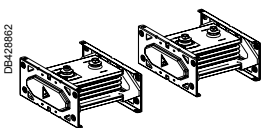
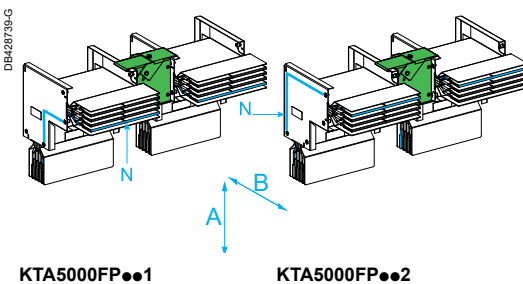

Type	Position of neutral	Cat. no.		
		3L + PE	3L + N + PE	3L + N + PER <sup>(1)</sup>
2 fixed branches	N1	KTA5000FP3A1	KTA5000FP4A1	KTA5000FP5A1
	N2	KTA5000FP3A2	KTA5000FP4A2	KTA5000FP5A2
1 made to measure short branche	N1	KTA5000FP3B1	KTA5000FP4B1	KTA5000FP5B1
	N2	KTA5000FP3B2	KTA5000FP4B2	KTA5000FP5B2
1 made to measure long branche	N1	KTA5000FP3D1	KTA5000FP4D1	KTA5000FP5D1
	N2	KTA5000FP3D2	KTA5000FP4D2	KTA5000FP5D2
2 made to measure branches	N1	KTA5000FP3E1	KTA5000FP4E1	KTA5000FP5E1
	N2	KTA5000FP3E2	KTA5000FP4E2	KTA5000FP5E2

(1) To order the 3L + N + PER version with reinforced lsc, replace KTA5000FP5... by KTA5000FP7....

2 x KTA2500FP...●●●

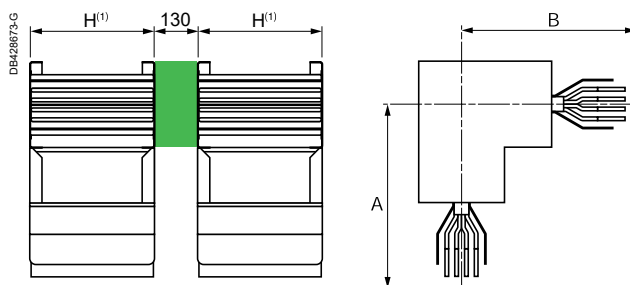

(1) See the "Trunking cross-section" table page 68 and dimensions page 64.

# Catalogue numbers and dimensions

## Fire rated edgewise elbows

### IP55

Compliant with the IEC 60331

### FC - Fire rated edgewise elbows

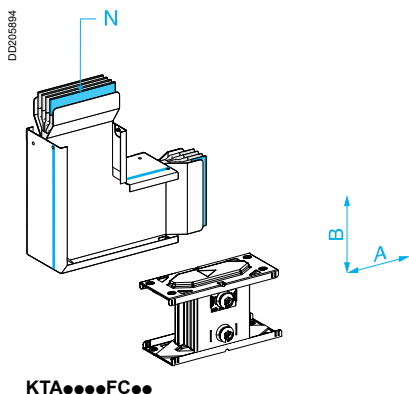

Type	Cat. no.		
	3L + PE	3L + N + PE <sup>(2)</sup>	3L + N + PER <sup>(1)</sup>
2 fixed branches	KTA...FC3A	KTA...FC4A	KTA...FC5A
1 made to measure short branche	KTA...FC3B	KTA...FC4B	KTA...FC5B
1 made to measure long branche	KTA...FC3D	KTA...FC4D	KTA...FC5D
2 made to measure branches	KTA...FC3E	KTA...FC4E	KTA...FC5E

(1) To order the 3L + N + PER version with reinforced lsc, replace KTA...FC5● by KTA...FC7●.  
 (2) To order the 3L + N + PE 2500 A and 3200 A version with reinforced lcc, replace KTA2500FC4● by KTA2500FC6● and KTA3200FC4● by KTA3200FC6●.

KTA...FC...

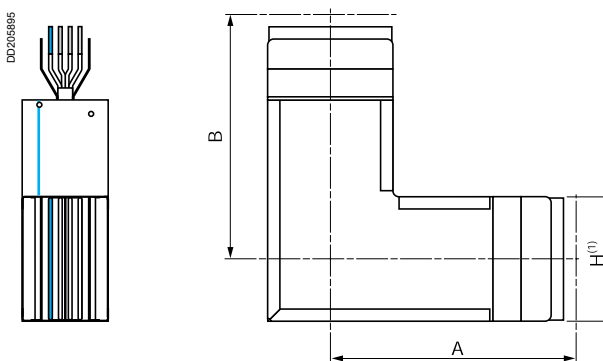

(1) See the "Trunking cross-section" table page 71 and dimensions page 64.

### Canalis KTA 5000

### FC - Fire rated edgewise elbows

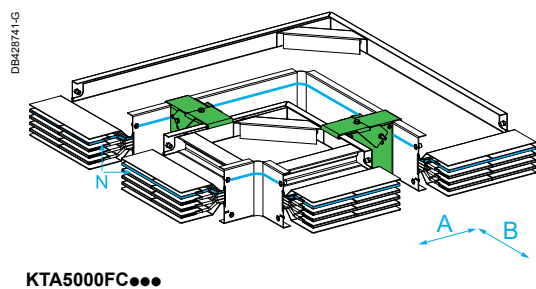

Type	Cat. no. <sup>(2)</sup>		
	3L + PE	3L + N + PE	3L + N + PER <sup>(1)</sup>
2 fixed branches	KTA5000FC3A	KTA5000FC4A	KTA5000FC5A
1 made to measure short branche	KTA5000FC3B	KTA5000FC4B	KTA5000FC5B

(1) To order the 3L + N + PER version with reinforced lsc, replace KTA5000FC5● by KTA5000FC7●.

2 x KTA2500FC...

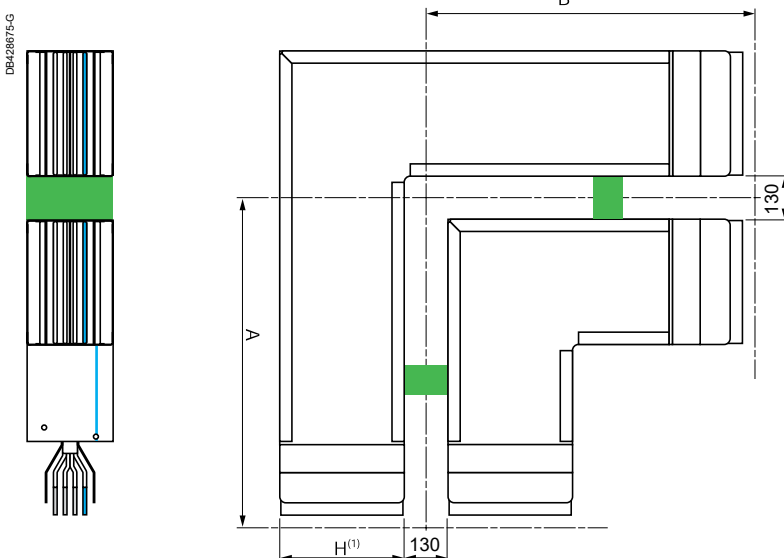
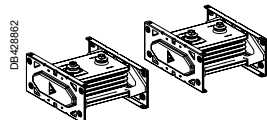

(1) See the "Trunking cross-section" table page 71 and dimensions page 64.

# Canalis interfaces for PrismaSeT LV switchboard

## Canalis KTA 800 to 5000

### Interfaces for Masterpact MTZ2/NW circuit breakers

A

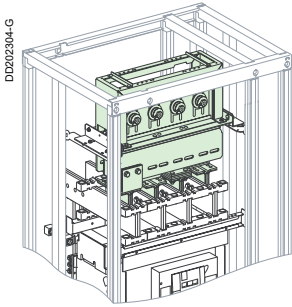

Top direct connection

C

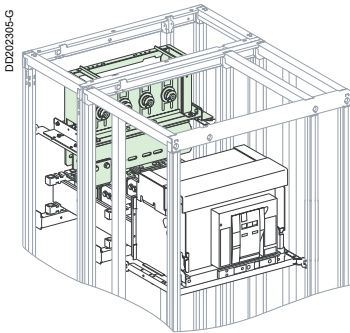

Rear connection

D

E

F

G

Interfaces can be ordered by 2 channels:

- as a Canalis KT product, in this case use the reference in this catalogue eg. **KTB04715**
- as a Prisma product, in this case replace the radical KTB by LVS to find the correct reference eg. **LVS04715**
- for MTZ3/NW63 in this case replace the radical KTB by LVMZ to find the correct reference e.g. **LVMZ1207**.

All accessories are only available as Prisma or Okken references.

All mounting instruction or other documents will be found by using the reference without **LVS** radical.

Circuit breaker	Type of circuit breaker	Canalis polarity	No. of poles of circuit breaker	Connection		Cat. no.
				Top direct	Rear	
MTZ2/ NW 08/16	Fixed or drawout	3L+PE	3P	■	■	KTB04715
		3L+N+PE	4P	■	■	KTB04716
		3L+N+PER	4P	■	■	KTB04716+KTB0164PE1
MTZ2/ NW 20/25	Fixed or drawout	3L+PE	3P	■	■	KTB04725
		3L+N+PE	4P	■	■	KTB04726
		3L+N+PER	4P	■	■	KTB04726+KTB0244PE1
MTZ2/ NW 32	Fixed or drawout	3L+PE	3P	■	■	KTB04735
		3L+N+PE	4P	■	■	KTB04736
		3L+N+PER	4P	■	■	KTB04736+KTB0404PE1
MTZ2/ NW 40	Fixed or drawout	3L+PE	3P		■	KTB04737
		3L+N+PE	4P		■	KTB04738
		3L+N+PER	4P		■	KTB04738+KTB0404PE1
MTZ3/ NW 40b-63	Drawout	3L+PE	3P	■		KTB1207
		3L+N+PE	4P	■		KTB1208
		3L+N+PER	4P	■		KTB1208+KTB0622PE1

For the position in the switchboard, see the "Installation guide".

### Number of modules required in the switchboard

Circuit breaker	Connection	Type of circuit breaker	Number of vertical modules <sup>(1)</sup>
MTZ2/NW 08/16	Top direct	Fixed or drawout	27
	Rear	Fixed	16
		Drawout	17
MTZ2/NW 20/32	Top direct	Fixed or drawout	28
	Rear	Fixed	16
		Drawout	17
MTZ2/NW 40	Rear	Fixed or drawout	36
MTZ3/NW 40b-63	Top direct	Drawout	38

(1) 1 module = 50 mm.

# Catalogue numbers and dimensions

## Canalis interfaces for PrismaSeT LV switchboard

### Canalis KTA 800 to 5000

#### Interfaces for Masterpact MTZ1/NT and Compact NS circuit breakers

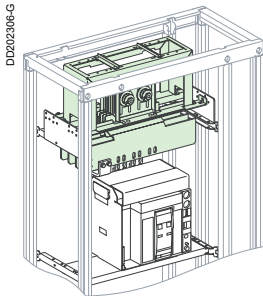

Top direct connection

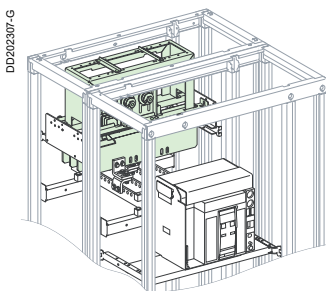

Rear connection

#### Masterpact MTZ1/NT

Circuit breaker	Type of circuit breaker	Canalis polarity	No. of poles of circuit breaker	Connection		Cat. no.
				Top direct	Rear	
MTZ1/NT 06/12	Fixed or drawout	3L+PE	3P	■	■	KTB04703
		3L+N+PE	4P	■	■	KTB04704
		3L+N+PER	4P	■	■	KTB04704+KTB0164PE1
MTZ1/NT 16	Fixed or drawout	3L+PE	3P		■	KTB04703
		3L+N+PE	4P		■	KTB04704
		3L+N+PER	4P		■	KTB04704+KTB0164PE1

For the position in the switchboard, see the "Installation guide".

#### Compact NS

Circuit breaker	Type of circuit breaker	Canalis polarity	No. of poles of circuit breaker	Connection		Cat. no.
				Top direct	Rear	
NS630b/1250	Fixed or drawout	3L+PE	3P	■	■	KTB04703
		3L+N+PE	4P	■	■	KTB04704
		3L+N+PER	4P	■	■	KTB04704+KTB0164PE1
NS1600	Fixed or drawout	3L+PE	3P		■	KTB04703
		3L+N+PE	4P		■	KTB04704
		3L+N+PER	4P		■	KTB04704+KTB0164PE1

For the position in the switchboard, see the "Installation guide".

#### Number of modules required in the switchboard

Circuit breaker	Connection	Type of circuit breaker	Number of vertical modules <sup>(1)</sup>
MTZ1/NT 06/12 NS630b/1250	Top direct	Fixed	17
		Drawout	18
MTZ1/NT 16 NS1600	Rear	Fixed or drawout	16
		Fixed or drawout	16

(1) 1 module = 50 mm.

# Canalis interfaces for PrismaSeT LV switchboard

## Canalis KTA 800 to 5000

### Interface supports and protection covers

- A
- B
- C
- D
- E
- F
- G

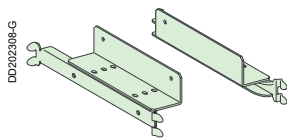

LVS03561

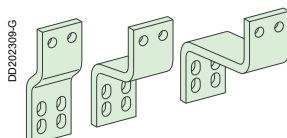

LVS04711  
LVS04712  
LVS04713  
LVS04714

#### Masterpact MTZ2/NW

Circuit breaker	Type of circuit breaker	Connection	Supports	Terminal extension bar supports	Cover
MTZ2/NW 08/32	Fixed or drawout	Top direct	LVS03561	3 x LVS04694	LVS04871 + LVS04861
		Rear	LVS03561	2 x LVS04694	LVS04871 + LVS04863
MTZ2/NW 40	Fixed or drawout	Top direct	LVS03561	-	LVS04871 + LVS04861
		Rear	LVS03561	-	LVS04871 + LVS04863
MTZ3/NW 40b-63	Drawout	Top direct	LVS04739	-	-

#### Masterpact MTZ1/NT

Circuit breaker	Type of circuit breaker	Canalis polarity	Connection	Supports	Canalis / circuit breaker connection	Cover
MTZ1/NT 06/12	Fixed or drawout	3P	Top direct	LVS03561	LVS04712	LVS04871 + LVS04852
			Rear	LVS03561	LVS04713	LVS04871 + LVS04853
		4P	Top direct	LVS03561	LVS04712	LVS04871 + LVS04852
			Rear	LVS03561	LVS04714	LVS04871 + LVS04853
MTZ1/NT 16	Fixed or drawout	3P	Rear	LVS03561	LVS04713	LVS04871 + LVS04854
			4P	Rear	LVS03561	LVS04714

#### Compact NS

Circuit breaker	Type of circuit breaker	Canalis polarity	Connection	Supports	Canalis / circuit breaker connection	Cover
NS630b/1250	Fixed	3P	Top direct	LVS03561	LVS04712	LVS04871 + LVS04851
			Rear	LVS03561	LVS04713	LVS04871 + LVS04853
		4P	Top direct	LVS03561	LVS04712	LVS04871 + LVS04851
			Rear	LVS03561	LVS04714	LVS04871 + LVS04853
	Drawout	3P	Top direct	LVS03561	LVS04711	LVS04871 + LVS04852
			Rear	LVS03561	LVS04713	LVS04871 + LVS04854
		4P	Top direct	LVS03561	LVS04712	LVS04871 + LVS04852
			Rear	LVS03561	LVS04714	LVS04871 + LVS04854
NS1600	Fixed	3P	Rear	LVS03561	LVS04713	LVS04871 + LVS04853
			4P	Rear	LVS03561	LVS04714
	Drawout	3P	Rear	LVS03561	LVS04713	LVS04871 + LVS04854
			4P	Rear	LVS03561	LVS04714

### Arc-chute covers

Circuit breaker	Type of circuit breaker	Canalis polarity	Cat. no.
Masterpact MTZ1/NT	Fixed	3P	47335
		4P	47336
Compact NS	Fixed	3P	33596
		4P	33597

# Catalogue numbers and dimensions

## Canalis interfaces for Okken LV switchboard

### Canalis KTA 800 to 5000

#### Interfaces for Masterpact MTZ2/NW circuit breakers

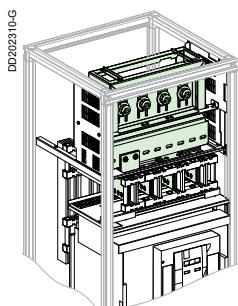

Top direct connection (RDH)

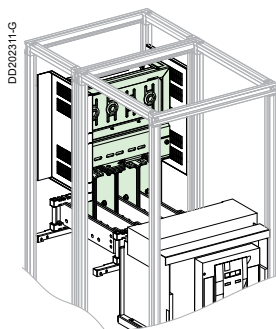

Rear connection (RAR)

Fitting the interface does not change switchboard modularity as fixed by the devices.

Circuit breaker	Type of circuit breaker	Canalis polarity	No. of poles of circuit breaker	Connection		Cat. no.
				Top direct	Rear	
MTZ2/NW 08/16	Drawout	3L+PE	3P	■	■	KTB87811
				■	■	KTB87821
		3L+N+PE	4P	■	■	KTB87812
				■	■	KTB87822
3L+N+PER	4P	■	■	KTB87812+KTB0164PE1		
		■	■	KTB87822+KTB0164PE1		
MTZ2/NW 20/25	Drawout	3L+PE	3P	■	■	KTB87813
				■	■	KTB87823
		3L+N+PE	4P	■	■	KTB87814
				■	■	KTB87824
3L+N+PER	4P	■	■	KTB87814+KTB0244PE1		
		■	■	KTB87824+KTB0244PE1		
MTZ2/NW 32	Drawout	3L+PE	3P	■	■	KTB87815
				■	■	KTB87825
		3L+N+PE	4P	■	■	KTB87816
				■	■	KTB87826
3L+N+PER	4P	■	■	KTB87816+KTB0404PE1		
		■	■	KTB87826+KTB0404PE1		
MTZ2/NW 40	Drawout	3L+PE	3P	■	■	KTB87817
				■	■	KTB87827
		3L+N+PE	4P	■	■	KTB87818
				■	■	KTB87828
3L+N+PER	4P	■	■	KTB87818+KTB0404PE1		
		■	■	KTB87828+KTB0404PE1		
MTZ3/NW 40b	Drawout	3L+PE	3P	■	■	KTB1203
		3L+N+PE	4P	■	■	KTB1204
		3L+N+PER	4P	■	■	KTB1204+KTB0404PE1
MTZ3/NW 50	Drawout	3L+PE	3P	■	■	KTB1207
		3L+N+PE	4P	■	■	KTB1208
		3L+N+PER	4P	■	■	KTB1208+KTB0622PE1

For the position in the switchboard, see the "Installation guide".

#### Interfaces for Masterpact MTZ1/NT circuit breakers

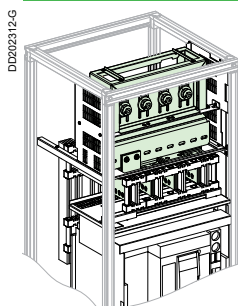

Top direct connection (RDH)

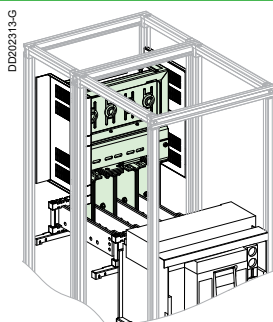

Rear connection (RAR)

Fitting the interface does not change switchboard modularity as fixed by the devices.

Circuit breaker	Type of circuit breaker	Canalis polarity	No. of poles of circuit breaker	Connection		Cat. no.
				Top direct	Rear	
MTZ1/NT 08/16	Drawout	3L+PE	3P	■	■	KTB87811
				■	■	KTB87821
		3L+N+PE	4P	■	■	KTB87812
				■	■	KTB87822
3L+N+PER	4P	■	■	KTB87812+KTB0164PE1		
		■	■	KTB87822+KTB0164PE1		

For the position in the switchboard, see the "Installation guide".

#### Interface supports

Circuit breaker	Type of circuit breaker	Connection	Cat. no.
MTZ2/NW 08/40	Drawout	Top direct	87800
MTZ1/NT 08/16			
MTZ2/NW 08/32 <sup>(1)</sup>	Drawout	Rear	87801
MTZ1/NT 08/16			

(1) Rear connection of the interface to a Masterpact MTZ2/NW 40 circuit breaker, the supports are supplied with the interface.

**Note:** For MTZ3/NW40 breaker with Rear connections interface supports as follows, 1200 mm Depth - Supports are supplied along with the interface. 1400 mm Depth - LVMZ2860X0 reference to be ordered separately.

Designation	Cat. no.
Special tightening wrench bit	87808

■ For 2 superimposed 120x10 bars.  
 ■ This tool is essential to tighten the conversion modules on the junction block's spreaders. It is fitted on a torque wrench.

# Sealing kits IP55

## Canalis KTA 800 to 5000

### TT - Sealing kits for switchboard and Trihal transformer roofs with interface

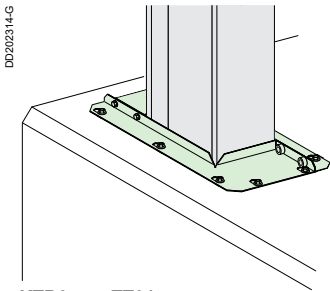

KTBO●●●TT01

Type	Rating of the trunking (A)	Height H of the trunking (mm)	Cat. no.
Sealing kit	800	74	KTB0074TT01
	1000	104	KTB0104TT01
	1250	124	KTB0124TT01
	1600	164	KTB0164TT01
	2000	204	KTB0204TT01
	2500	244	KTB0244TT01
	3200	324	KTB0324TT01
	4000	404	KTB0404TT01

### PE - Reinforced protective earth (PER) for PrismaSeT and Okken interfaces

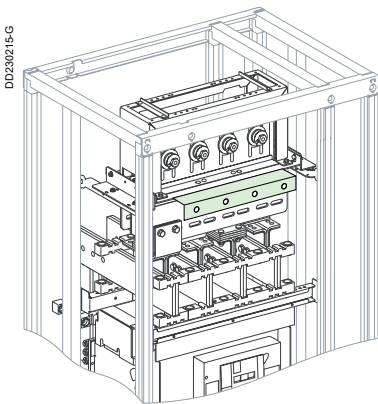

KTBO●●●PE1

Height "H" (mm)	Number of holes	Cat.no.
164	2	KTB0164PE1
244	3	KTB0244PE1
404	4	KTB0404PE1

KTBO●●●PE1

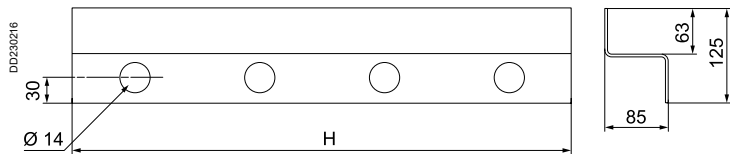

Thickness: 3 mm.

## Canalis KTA 5000

### TT - Sealing kits for switchboard and Trihal transformer roofs with interface

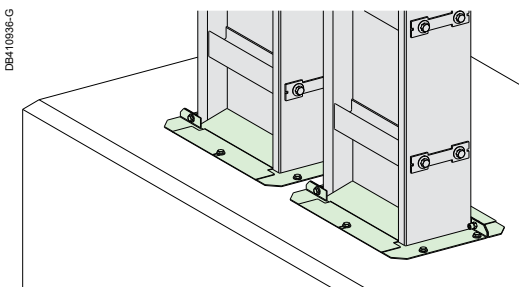

KTBO622TT01

Type	Rating of the trunking (A)	Height H of the trunking (mm)	Cat. no.
Sealing kit	5000	622	KTB0622TT01

### PE - Reinforced protective earth (PER) for PrismaSeT and Okken interfaces

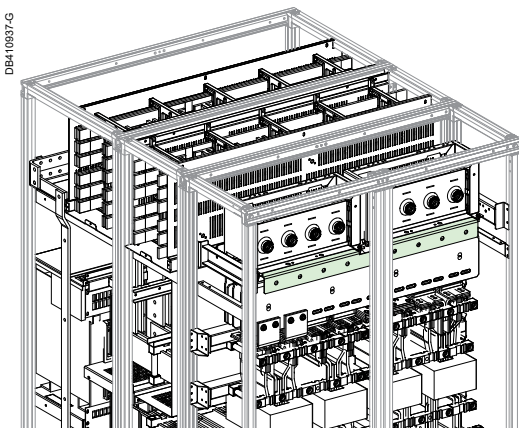

KTBO622PE1

Height "H" (mm)	Number of holes	Cat.no.
622	8	KTB0622PE1

KTBO622PE1

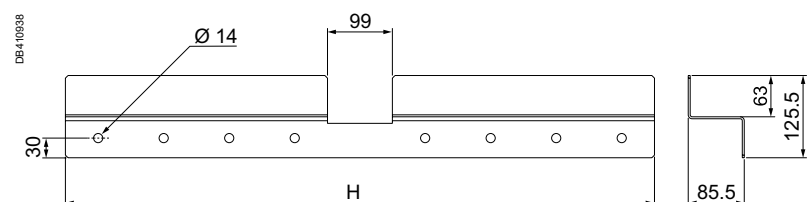

Thickness: 3 mm.

# Catalogue numbers and dimensions

## Feed units for switchboards and oil immersed transformers

### IP55

### Ordering

Complete the catalogue number by replacing "●●●●" by the rating.

#### Important:

- in the catalogue number for the 800 A rating, add a "0": **KTA0800**
- add the dimensions of the selected unit as a technical comment.

**Example:** the catalogue number of a 1250 A made to measure end feed unit, N2, 3L + N + PE, 235 mm long and with between centres J, K and M = 170 mm, is: **KTA1250ER42, A = 235, J = 170, K = 170 and M = 170.**



### ER●1, ER●2 - Straight feed units

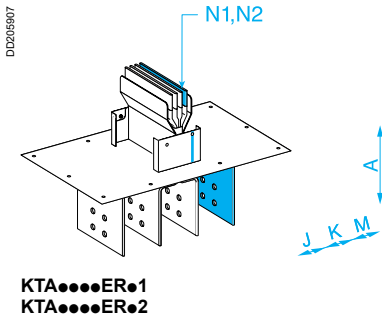

Type	Position of neutral	Cat. no.		
		3L + PE	3L + N + PE <sup>(2)</sup>	3L + N + PER <sup>(1)</sup>
Fixed	N1	KTA●●●●ER31	KTA●●●●ER41	KTA●●●●ER51
Made to measure	N2	KTA●●●●ER32	KTA●●●●ER42	KTA●●●●ER52

- (1) To order the 3L + N + PER version with reinforced Isc, replace KTA●●●●ER5● by KTA●●●●ER7●.
- (2) To order the 3L + N + PE 2500 A and 3200 A version with reinforced Isc, replace KTA2500ER4● by KTA2500ER6● and KTA3200ER4● by KTA3200ER6●.

These end feed units are supplied with a connection kit to create a PEN if needed.

#### KTA●●●●ER●1, KTA●●●●ER●2 3L + N + PE or PER

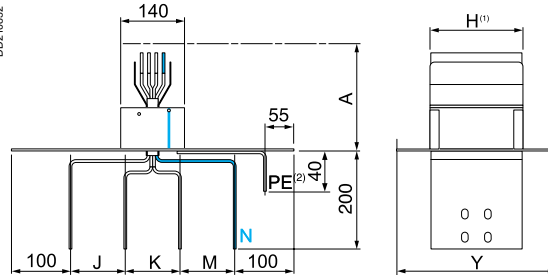

#### 3L + PE

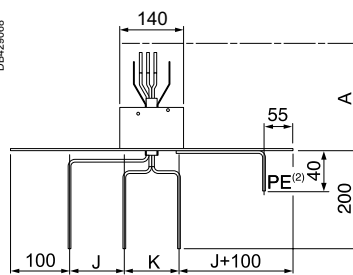

- (1) See the "Trunking cross-section" table in the following page.
- (2) PE drilled diameter = 14 mm pour cables with crimped lugs.

#### Table of dimensions

Rating (A)	Neutral	Dimensions (mm)		
		A	J, K, M	Y
800 <sup>(3)</sup> to 1250	N1	235	115	230
1250	N2	235 to 734	80 to 250	230
1600 to 2500	N1	235	115	350
2500	N2	235 to 734	80 to 250	350
3200 to 4000	N1	235	115	510
4000	N2	235 to 734	80 to 250	510

(3) For the 800 A rating, indicate "KTA0800".

### Dimensions of connection pads

Rating (A)	800	1000	1250	1600	2000	2500	3200	4000	5000
Drilling for connection (mm) Thickness of conductor = 6 mm.									



# Catalogue numbers and dimensions

## Feed units for switchboards and oil immersed transformers

### IP55

### Canalis KTA 800 to 4000

#### ER3, ER4 - Flat elbow feed units

A

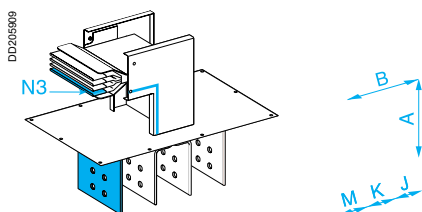

KTA...ER3

B

C

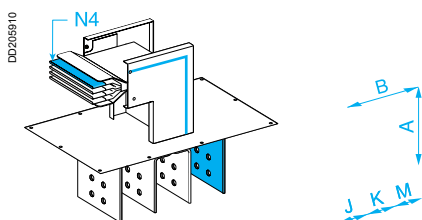

KTA...ER4

D

E

F

G

Type	Position of neutral	Cat. no.		
		3L + PE	3L + N + PE <sup>(2)</sup>	3L + N + PER <sup>(1)</sup>
Made to measure	N3	KTA...ER33	KTA...ER43	KTA...ER53
	N4	KTA...ER34	KTA...ER44	KTA...ER54

(1) To order the 3L + N + PER version with reinforced Isc, replace KTA...ER5 by KTA...ER7.  
 (2) To order the 3L + N + PE 2500 A and 3200 A version with reinforced Isc, replace KTA2500ER4 by KTA2500ER6 and KTA3200ER4 by KTA3200ER6.

KTA...ER3<sup>(3)</sup>, 3L + N + PE or PER KTA...ER4<sup>(3)</sup>, 3L + N + PE or PER

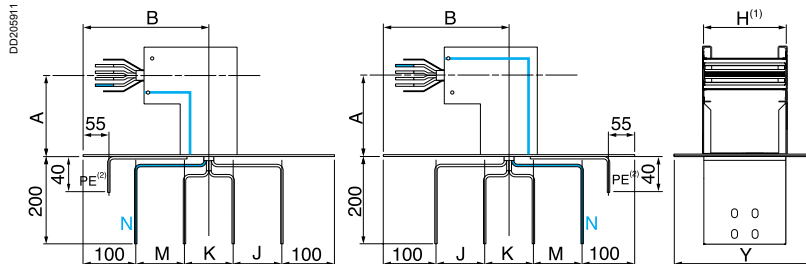

(1) See the "Trunking cross-section" table below.  
 (2) PE drilled diameter = 14 mm pour cables with crimped lugs.  
 (3) 3L + PE version, see page 79.

These end feed units are supplied with a connection kit to create a PEN if needed.

#### Tableau of dimensions

Rating (A)	Neutral	Dimensions (mm)			
		A	B	J, K, M	Y
800 <sup>(4)</sup> to 1250	N3, N4	200 to 534	300	80 to 250	230
1600 to 2500	N3, N4	200 to 534	300	80 to 250	350
3200 to 4000	N3, N4	200 to 534	300	80 to 250	510

(4) For the 800 A rating, indicate "KTA0800".

#### Cut-out drawing for feed units placed directly on the device roof

##### Table of dimensions

Rating (A)	Dimensions (mm)		
	Y	U	V
800 <sup>(1)</sup> to 1250	230	K/2 + J + 80	K/2 + M + 80
1600 to 2500	350	K/2 + J + 80	K/2 + M + 80
3200 to 4000	510	K/2 + J + 80	K/2 + M + 80
5000	350	K/2 + J + 80	K/2 + M + 80

(1) For the 800 A rating, indicate "KTA0800".

For the 3L + PE version, consider M = J to calculate the Y quotation.

##### 800 to 4000 A

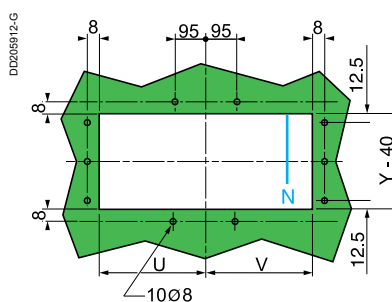

##### 5000 A

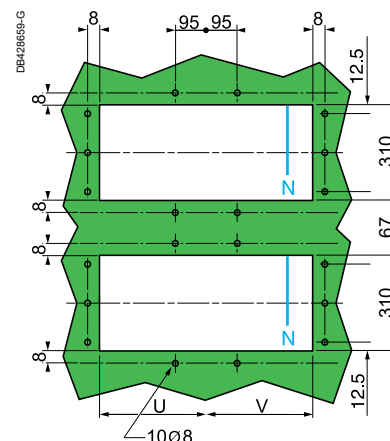

#### Trunking cross-section

Rating (A)	800 <sup>(1)</sup>	1000	1250	1600	2000	2500	3200	4000	5000
Weight (kg/m)	3L + PE	12	14	16	19	22	25	31	50
	3L + N + PE	13	16	18	22	26	30	37	60
	3L + N + PER	15	19	21	26	31	36	46	72

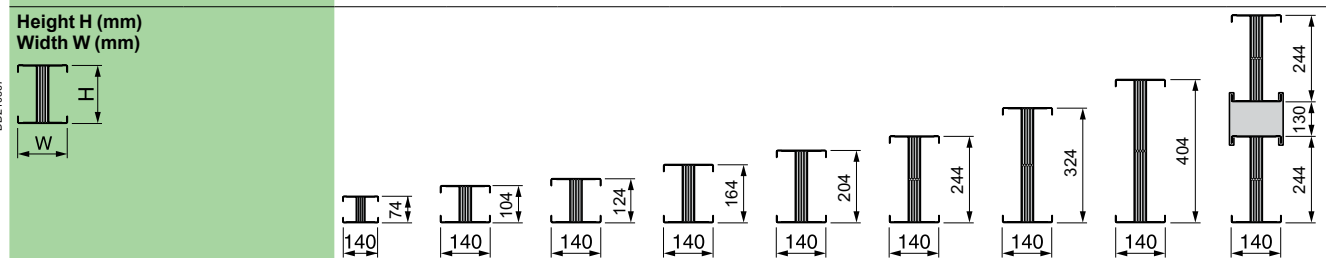

(1) Important: for the 800 A rating, indicate "KTA0800".

# Catalogue numbers and dimensions

## Feed units for switchboards and oil immersed transformers

### IP55

### ER•5, ER•6 - Edgewise elbow feed units

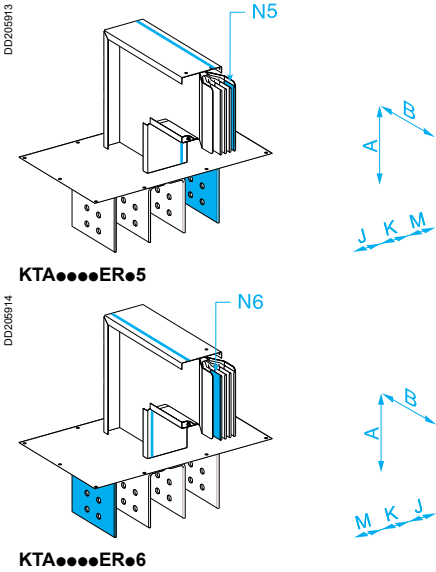

Type	Position of neutral	Cat. no.		
		3L + PE	3L + N + PE <sup>(2)</sup>	3L + N + PER <sup>(1)</sup>
Made to measure	N5	KTA••••ER35	KTA••••ER45	KTA••••ER55
	N6	KTA••••ER36	KTA••••ER46	KTA••••ER56

(1) To order the 3L + N + PER version with reinforced Isc, replace KTA••••ER5• by KTA••••ER7•.  
 (2) To order the 3L + N + PE 2500 A and 3200 A version with reinforced Isc, replace KTA2500ER4• by KTA2500ER6• and KTA3200ER4• by KTA3200ER6•.

KTA••••ER5<sup>(3)</sup>, 3L + N + PE or PER    KTA••••ER6<sup>(3)</sup>, 3L + N + PE or PER

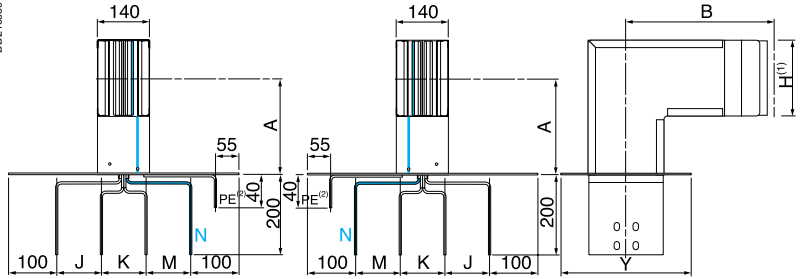

Table of dimensions

Rating (A)	Neutral	Dimensions (mm)			
		A	B	J, K, M	Y
800 <sup>(4)</sup>	N5, N6	175 to 509	275	80 to 250	230
1000	N5, N6	190 to 524	290	80 to 250	230
1250	N5, N6	200 to 534	300	80 to 250	230
1600	N5, N6	220 to 554	320	80 to 250	350
2000	N5, N6	240 to 574	340	80 to 250	350
2500	N5, N6	260 to 594	360	80 to 250	350
3200	N5, N6	300 to 634	400	80 to 250	510
4000	N5, N6	340 to 674	440	80 to 250	510

- (1) See the "Trunking cross-section" table opposite.
- (2) PE drilled diameter = 14 mm pour cables with crimped lugs.
- (3) 3L + PE version, see page 79.
- (4) For the 800 A rating, indicate "KTA0800".

### Cut-out drawing for feed units placed directly on the device

Table of dimensions

Rating (A)	Dimensions (mm)		
	Y	U	V
800 <sup>(1)</sup> to 1250	230	K/2 + J + 80	K/2 + M + 80
1600 to 2500	350	K/2 + J + 80	K/2 + M + 80
3200 to 4000	510	K/2 + J + 80	K/2 + M + 80
5000	350	K/2 + J + 80	K/2 + M + 80

(1) For the 800 A rating, indicate "KTA0800".

For the 3L + PE version, consider M = J to calculate the Y quotation.

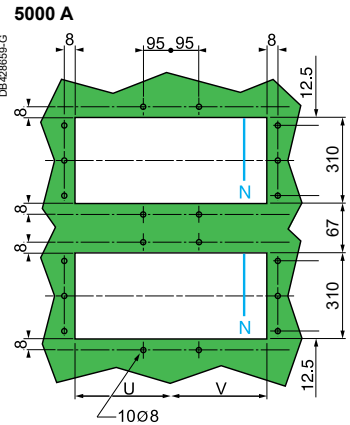
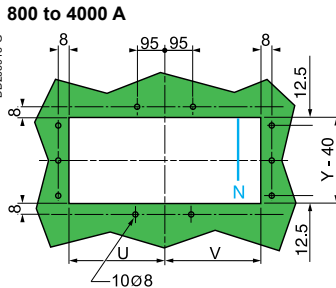

### Dimensions of connection pads

Rating (A)	800	1000	1250	1600	2000	2500	3200	4000	5000
Drilling for connection (mm)									
Thickness of conductor = 6 mm.									

# Catalogue numbers and dimensions

## Feed units for switchboards and oil immersed transformers

IP55

Canalis KTA 5000

### ER•1, ER•2 - Straight feed units

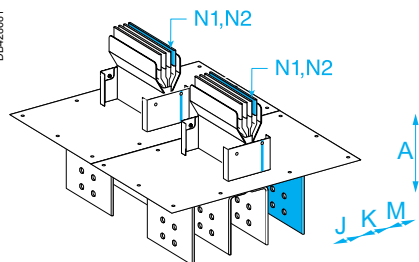

KTA5000ER•1  
KTA5000ER•2

Type	Position of neutral	Cat. no.		
		3L + PE	3L + N + PE	3L + N + PER <sup>(1)</sup>
Fixed	N1	KTA5000ER31	KTA5000ER41	KTA5000ER51
Made to measure	N2	KTA5000ER32	KTA5000ER42	KTA5000ER52

(1) To order the 3L + N + PER version with reinforced Icc, replace KTA5000ER5• by KTA5000ER7•.

**KTA5000ER•1, KTA5000ER•2**  
3L + N + PE or PER

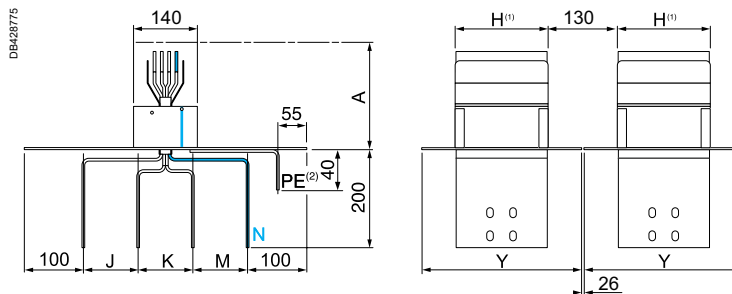

**3L + PE**

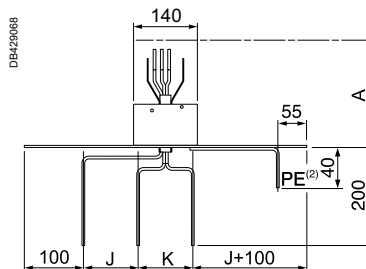

- (1) See the "Trunking cross-section" table page 85.
- (2) PE drilled diameter = 14 mm pour cables with crimped lugs.

**Table of dimensions**

Rating (A)	Neutral	Dimensions (mm)		
		A	J, K, M	Y
5000	N1	235	115	350
	N2	235 to 734	80 to 250	350

# Catalogue numbers and dimensions

## Feed units for switchboards and oil immersed transformers

### IP55

#### ER●3, ER●4 - Flat elbow feed units

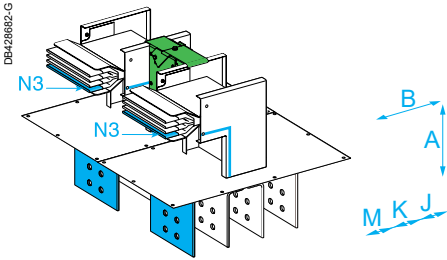

**KTA5000ER3**

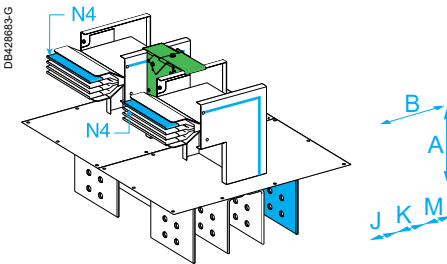

**KTA5000ER4**

Type	Position of neutral	Cat. no.		
		3L + PE	3L + N + PE	3L + N + PER <sup>(1)</sup>
Made to measure	N3	<b>KTA5000ER33</b>	<b>KTA5000ER43</b>	<b>KTA5000ER53</b>
	N4	<b>KTA5000ER34</b>	<b>KTA5000ER44</b>	<b>KTA5000ER54</b>

(1) To order the 3L + N + PER version with reinforced Icc, replace KTA5000ER5● by KTA5000ER7●.

**KTA5000ER●3 <sup>(3)</sup>, 3L + N + PE or PER**

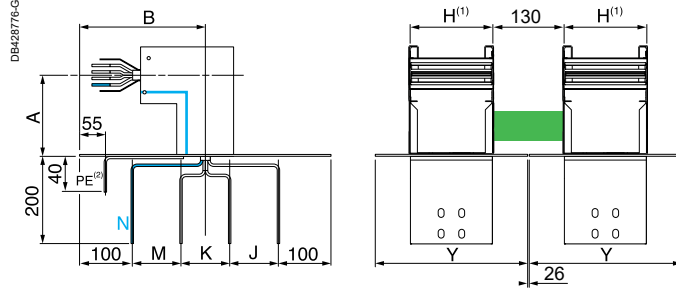

**KTA5000ER●4 <sup>(3)</sup>, 3L + N + PE or PER**

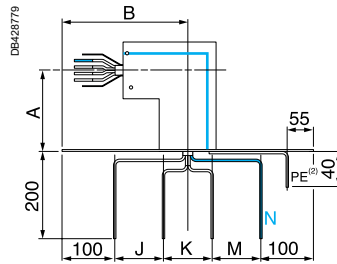

- (1) See the "Trunking cross-section" table page 85.
- (2) PE drilled diameter = 14 mm pour cables with crimped lugs.
- (3) 3L + PE version, see page 79.

**Tableau of dimensions**

Rating (A)	Neutral	Dimensions (mm)			
		A	B	J, K, M	Y
5000	N3, N4	200 to 534	300	80 to 250	350



# Catalogue numbers and dimensions

## Feed units for switchboards and oil immersed transformers

IP55

Canalis KTA 5000

### ER•5, ER•6 - Edgewise elbow feed units

A

DB428684-G

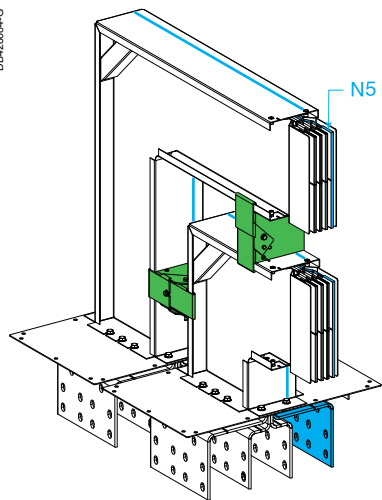

KTA5000ER•5



D

E

DB428685-G

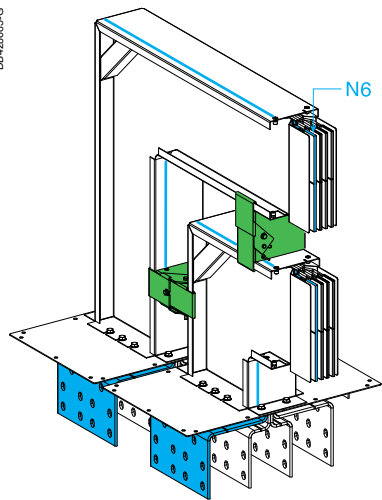

KTA5000ER•6



F

G

Type	Position of neutral	Cat. no.		
		3L + PE	3L + N + PE	3L + N + PER <sup>(1)</sup>
Made to measure	N5	KTA5000ER35	KTA5000ER45	KTA5000ER55
	N6	KTA5000ER36	KTA5000ER46	KTA5000ER56

(1) To order the 3L + N + PER version with reinforced lcc, replace KTA5000ER5• by KTA5000ER7•.

KTA5000ER•5 <sup>(3)</sup>, 3L + N + PE or PER

DB42877-G

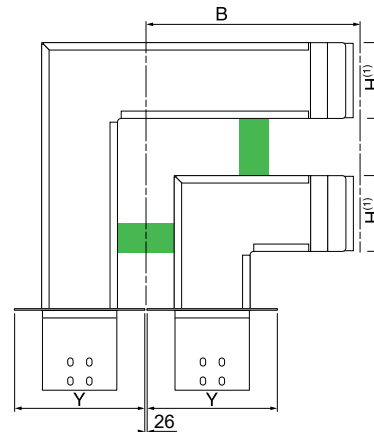
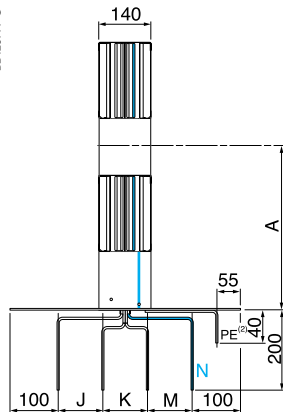

KTA5000ER•6 <sup>(3)</sup>, 3L + N + PE or PER

DB428778

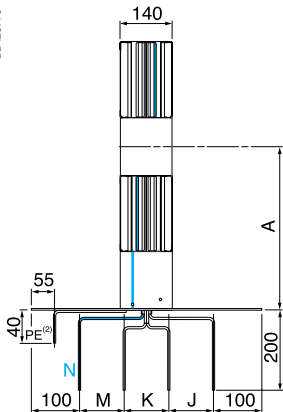

- (1) See the "Trunking cross-section" table page 85.
- (2) PE drilled diameter = 14 mm pour cables with crimped lugs.
- (3) 3L + PE version, see page 79.

#### Table of dimensions

Rating (A)	Neutral	Dimensions (mm)			
		A	B	J, K, M	Y
5000	N3, N4	448 to 782	548	80 to 250	350

# Catalogue numbers and dimensions

## Feed units for switchboards and oil immersed transformers

### IP55

### Canalis KTA 800 to 4000

#### ER7 - Bar feed units, flat outlets

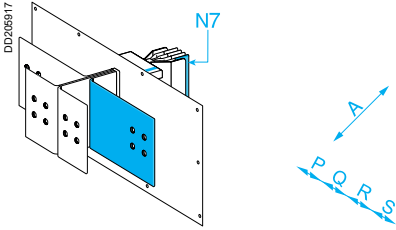

KTA●●●●ER7

Type	Cat. no. <sup>(3)</sup>		
	3L + PE	3L + N + PE <sup>(2)</sup>	3L + N + PER <sup>(1)</sup>
Made to measure	KTA●●●●ER37	KTA●●●●ER47	KTA●●●●ER57

- (1) To order the 3L + N + PER version with reinforced Isc, replace KTA●●●●ER57 by KTA●●●●ER77.
- (2) To order the 3L + N + PE 2500 A and 3200 A version with reinforced Isc, replace KTA2500ER4● by KTA2500ER6● and KTA3200ER4● by KTA3200ER6●.
- (3) Not available for KTA5000.

Connection pad dimensions are identical to those of the feed units.

KTA●●●●ER7  
3L + N + PE or PER

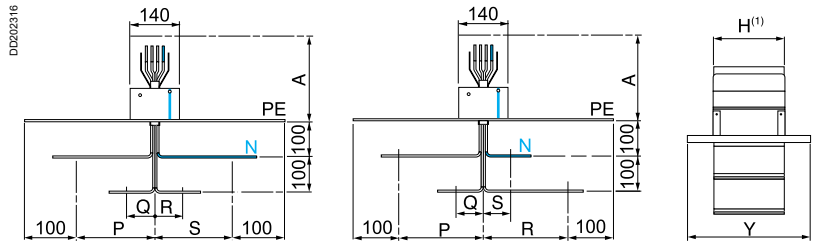

3L + PE

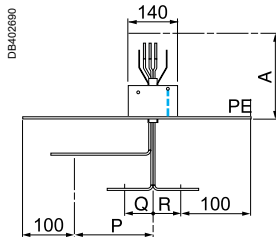

(1) See the "Trunking cross-section" table below.

Table of dimensions

Rating (A)	Dimensions (mm)				
	A	P - Q	S - R or R - S	Q, R, S minimum	Y
800 <sup>(2)</sup> to 1250	235 to 734	160 to 600	160 to 600	80	230
1600 to 2500	235 to 734	160 to 600	160 to 600	80	350
3200 to 4000	235 to 734	160 to 600	160 to 600	80	510

(2) For the 800 A rating, indicate "KTA0800".

#### Cut-out drawing for straight feed units connected directly to the device

Table of dimensions

Rating (A)	Dimensions (mm)		
	Y	U	V
800 <sup>(1)</sup> to 1250	230	U = P + 80	if S > R, V = S + 80
1600 to 2500	350		if R > S, V = R + 80
3200 to 4000	510		

(1) For the 800 A rating, indicate "KTA0800".

For the 3L + PE version, consider S = 0 to calculate the V quotation.

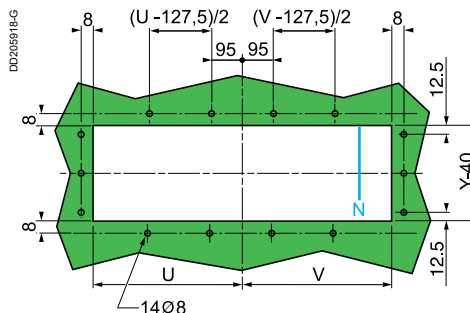

#### Trunking cross-section

Rating (A)	800 <sup>(1)</sup>	1000	1250	1600	2000	2500	3200	4000	5000
Weight (kg/m)									
	3L + PE	12	14	16	19	22	25	31	50
	3L + N + PE	13	16	18	22	26	30	37	60
	3L + N + PER	15	19	21	26	31	36	56	72

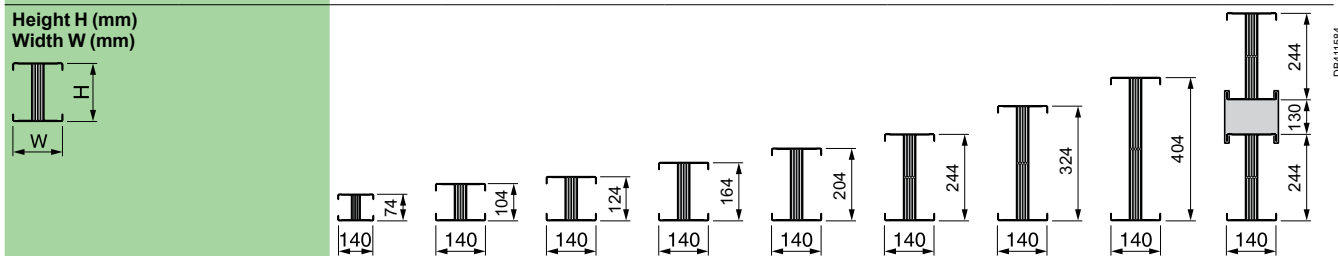

(1) Important: for the 800 A rating, indicate "KTA0800".

# Rigid protective covers IP55

## Canalis KTA 800 to 5000

A

B

C

D

E

F

G

### Ordering

To order a protective cover onto which a feed connector is fitted, the parameters D, G and Z, which depend on the feed connector, must be given.

Example: the catalogue number of a rigid vertical protective cover with dimension Y = 350 mm intended for a feed unit with different between centre dimensions D, G and Z (in mm) is:

**KTB0350CR2, D = 330, G = 450 and Z = 500.**

### CR1 - Rigid horizontal protective covers for feed units ER N1 to N7

**Important:** when ordering a horizontal cover, make sure you indicate dimensions "D, G and Z" with the catalogue number.

Rating (A)	Dimensions "Y" (mm)	Cat. no.	Weight (kg)
800 to 1250	230	<b>KTB0230CR1</b>	12.00
1600 to 2500	350	<b>KTB0350CR1</b>	12.00
3200 to 4000	510	<b>KTB0510CR1</b>	12.00
5000	350	<b>KTB0726CR1</b>	60.00

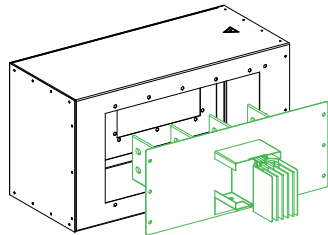

KTB...CR1

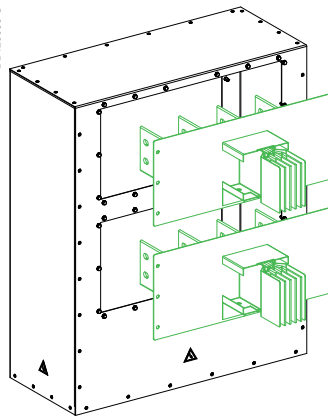

KTB0726CR1

KTB...CR1

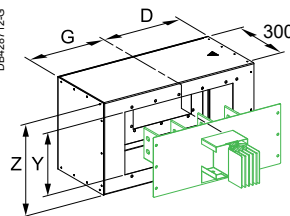

KTB0726CR1

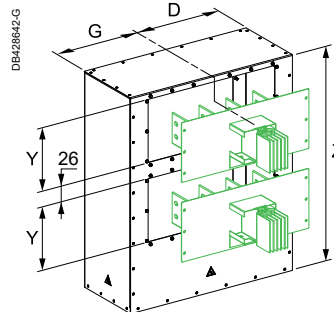

#### Protective cover for ER N1 to N6 straight end feed connectors

Dimensions **D** and **G** are determined by the between centres dimensions (J, K and M) of the end feed connector bars to be protected. The position of the neutral on the feed connector also determines the rule to be used for calculating parameters **D** and **G**.

If the feed connector comes into the cover with the neutral on the right:

$$D = K/2 + M + 100^{(1)}$$

$$G = K/2 + J + 100^{(1)}$$

If the feed connector comes into the cover with the neutral on the left:

$$D = K/2 + J + 100^{(1)}$$

$$G = K/2 + M + 100^{(1)}$$

<sup>(1)</sup> = For calculating 5000A = D & G values.

$$D = K/2 + J + 172.5$$

$$G = K/2 + M + 172.5$$

For the 3L + PE version, consider **M = J** to calculate the **D** and **G** quotations.

#### Table of dimensions

Rating (A)	Dimensions (mm)			
	Y	D	G	Z
800 to 1250	230	220 to 475	220 to 475	310 to 800
1600 to 2500	350	220 to 475	220 to 475	430 to 800
3200 to 4000	510	220 to 475	220 to 475	590 to 800
5000	726	292.5 to 547.5	292.5 to 547.5	790 to 1200

#### Protective cover for ER N7 straight end feed connectors

Dimensions **D** and **G** are determined by the between centres dimensions (P, Q, R and S) of the end feed connector bars to be protected.

Position of the neutral on the feed connector also determines the rule to be used for calculating parameters **D** and **G**.

If the feed connector comes into the cover with the neutral on the right:

$$D = \max(R; S) + 100$$

$$G = \max(P; Q) + 100$$

If the feed connector comes into the cover with the neutral on the left:

$$D = \max(P; Q) + 100$$

$$G = \max(R; S) + 100$$

For the 3L + PE version, consider **S = 0** to calculate the **D** and **G** quotations.

#### Table of dimensions

Rating (A)	Dimensions (mm)			
	Y	D	G	Z
800 to 1250	230	340 to 1000	340 to 1000	310 to 800
1600 to 2500	350	340 to 1000	340 to 1000	430 to 800
3200 to 4000	510	340 to 1000	340 to 1000	590 to 800

# Catalogue numbers and dimensions

## Rigid protective covers

### IP55

### CR2, CR3 - Rigid vertical protective covers for feed units ER N1 to N7

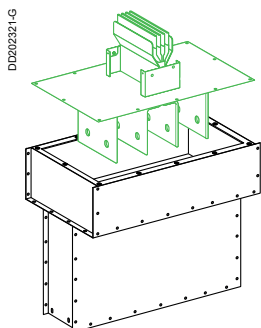

KTB●●●●CR2

**Important:** when ordering a vertical cover, make sure you indicate dimensions "D, G and Z" with the catalogue number.

#### 400 to 800 mm high covers

Rating (A)	Dimensions "Y" (mm)	Cat. no.	Weight (kg)
800 to 1250	230	KTB0230CR2	40.00
1600 to 2500	350	KTB0350CR2	40.00
3200 to 4000	510	KTB0510CR2	40.00

#### KTB●●●●CR2

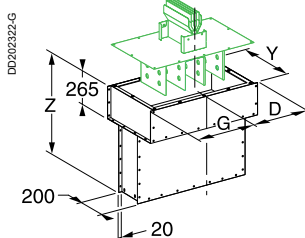

Dimensions **D** and **G** are determined by the between centres dimensions (J, K and M) of the end feed connector bars to be protected.

$D = K/2 + J + 100$   
 $G = K/2 + M + 100$

For the 3L + PE version, consider  $M = J$  to calculate the D and G quotations.

#### Table of dimensions for ER N1 to N6 straight feed units

Rating (A)	Dimensions (mm)			
	Y	D	G	Z
800 to 1250	230	220 to 475	220 to 475	400 to 800
1600 to 2500	350	220 to 475	220 to 475	400 to 800
3200 to 4000	510	220 to 475	220 to 475	400 to 800

#### 100 to 400 mm high covers

Rating (A)	Dimensions "Y" (mm)	Cat. no.	Weight (kg)
800 to 1250	230	KTB0230CR3	17.00
1600 to 2500	350	KTB0350CR3	17.00
3200 to 4000	510	KTB0510CR3	17.00
5000	350	KTB0726CR3	60.00

#### KTB●●●●CR3

#### KTB0726CR3

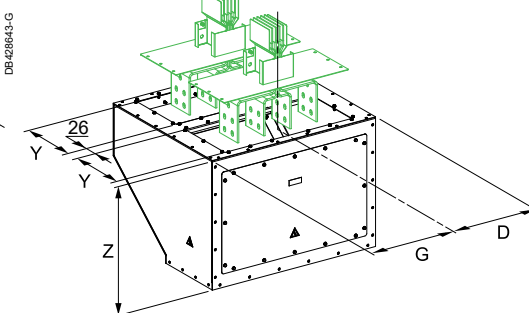
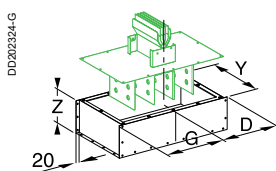

Dimensions **D** and **G** are determined by the between centres dimensions of the end feed connector bars to be protected.

#### Table of dimensions for ER N1 to N6 straight feed units

Rating (A)	Dimensions (mm)			
	Y	D	G	Z
800 to 1250	230	238.5 to 493.5	238.5 to 493.5	100 to 400
1600 to 2500	350	238.5 to 493.5	238.5 to 493.5	100 to 400
3200 to 4000	510	238.5 to 493.5	238.5 to 493.5	100 to 400
5000	350	292.5 to 547.5	292.5 to 547.5	591 to 800

$D = K/2 + J + 118.5^{(1)}$   
 $G = K/2 + M + 118.5^{(1)}$

For the 3L + PE version, consider  $M = J$  to calculate the D and G quotations.

(1) = For calculating 5000 A = D & G values.

$D = K/2 + J + 172.5$   
 $G = K/2 + M + 172.5$

#### Table of dimensions for ER N7 straight feed units

Rating (A)	Dimensions (mm)			
	Y	D	G	Z
800 to 1250	230	220 to 475	220 to 475	100 to 400
1600 to 2500	350	220 to 475	220 to 475	100 to 400
3200 to 4000	510	220 to 475	220 to 475	100 to 400

$D = \max(P; Q) + 100$   
 $G = \max(R; S) + 100$

For the 3L + PE version, consider  $S = 0$  to calculate the D and G quotations.

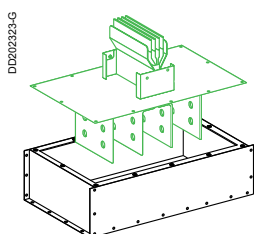

KTB●●●●CR3

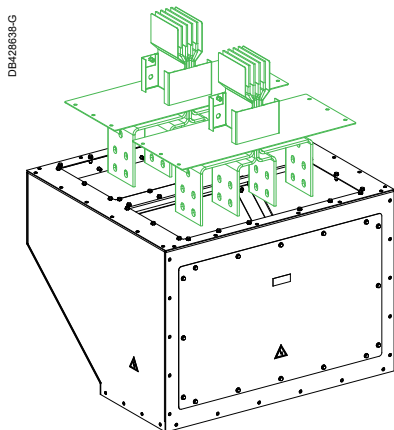

KTB0726CR3

A

B

C

D

E

F

G

# Catalogue numbers and dimensions

## Adjustable protective covers for Minera immersed transformers

### IP55

#### Canalis KTA 800 to 5000

### CR7 - Protective covers for horizontal incomers

These covers are used to connect Canalis KT to Minera transformers. Dimensions are predefined to match with transformer ratings. Refer to the selection guide, see page 236.

Cat. no.	Y (mm)	Z (mm)	X (mm)	A (mm)	B (mm)	C (mm)	Weight (kg)
<b>KTB0230CR71</b>	230	450	320	780	650	256	30
<b>KTB0350CR71</b>	350	510	320	780	650	256	30
<b>KTB0350CR72</b>	350	540	350	780	650	256	30
<b>KTB0350CR73</b>	350	590	400	855	710	276	30
<b>KTB0350CR74</b>	350	590	400	855	710	359	30
<b>KTB0510CR71</b>	510	705	435	855	710	276	30
<b>KTB0510CR72</b>	510	740	470	855	710	359	30
<b>KTB0510CR73</b>	510	780	510	855	710	359	30
<b>KTB0726CR71</b>	350	1025	469	855	710	359	30

A

B

C

D

E

F

G

DB428457-G

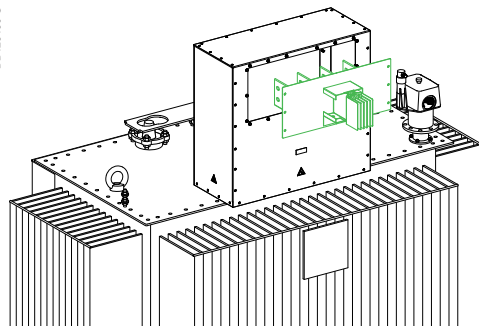

KTB●●●●CR7●

KTB●●●●CR7●

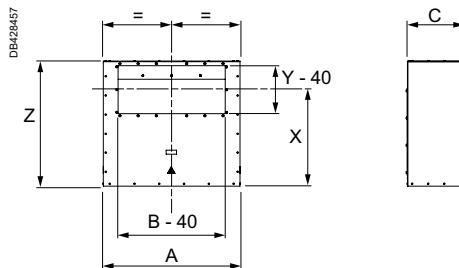

DB428638-G

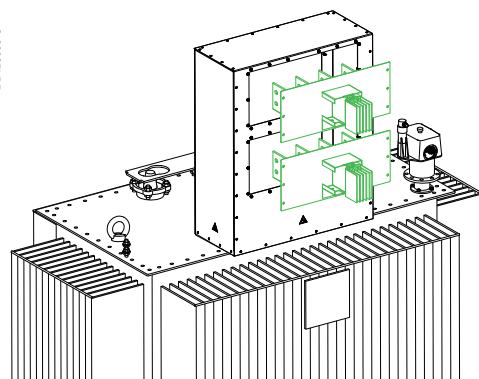

KTB0726CR71

KTB0726CR71

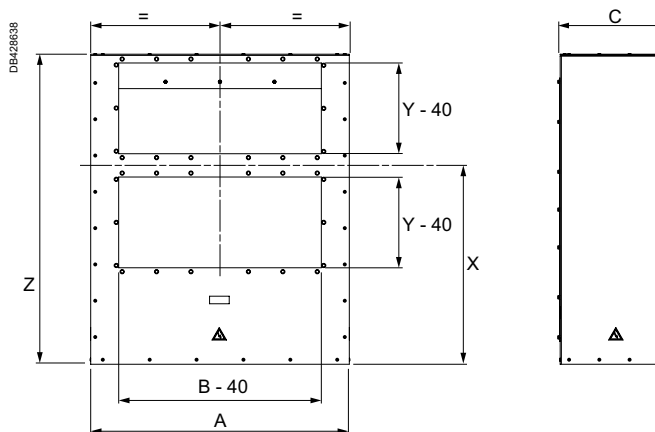

# Catalogue numbers and dimensions

## Adjustable protective covers for Minera immersed transformers

### IP55

#### CR8 - Protective covers for vertical incomers

These covers are used to connect Canalis KT to Minera transformers. Dimensions are predefined to match with transformer ratings. Refer to the selection guide, page 238.

Cat. no.	Y (mm)	Z (mm)	A (mm)	B (mm)	C (mm)	Weight (kg)
<b>KTB0230CR81</b>	230	480	780	650	251	30
<b>KTB0350CR81</b>	350	580	780	650	380	30
<b>KTB0350CR82</b>	350	600	855	710	380	30
<b>KTB0350CR83</b>	350	520	855	710	380	30
<b>KTB0510CR81</b>	510	600	855	710	540	30
<b>KTB0510CR82</b>	510	615	855	710	540	30
<b>KTB0726CR81</b>	350	591	775	710	770	30

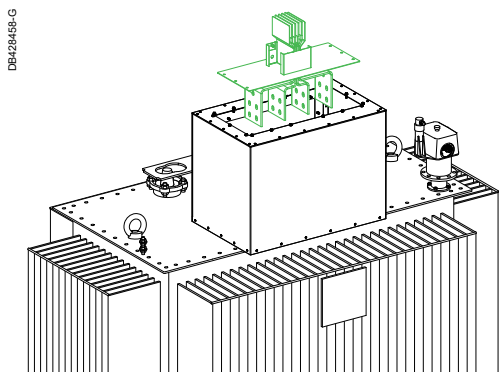

KTB0230CR81

KTB0230CR81

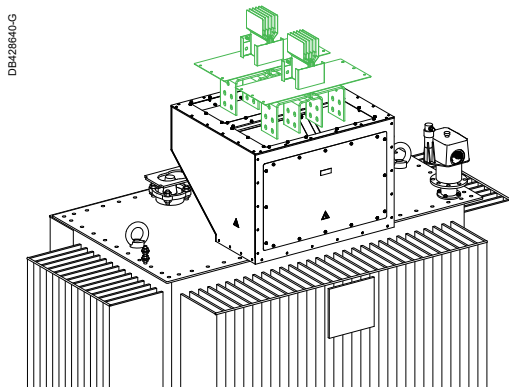
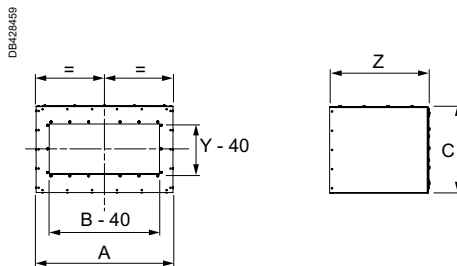

KTB0726CR81

KTB0726CR81

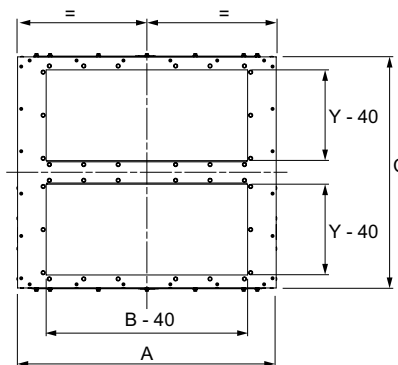
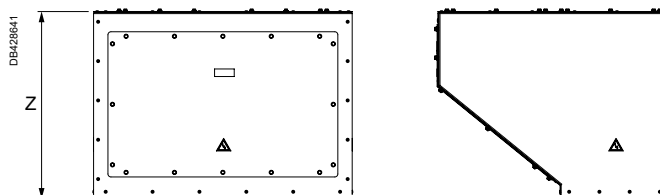

# Flexible protective covers Cable boxes IP55

## Canalis KTA 800 to 4000

### CS - Flexible vertical protective covers for straight feed units

A

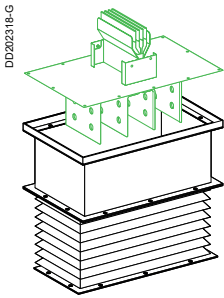

KTB...CS0

Covers for ER N1 to N7 straight feed units with **between centre dimensions = 115 mm**.

Rating (A)	Dimensions "Y" (mm)	Cat. no.	Weight (kg)
800 to 1250	230	<b>KTB0230CS0</b>	15.00
1600 to 2500	350	<b>KTB0350CS0</b>	17.00
3200 to 4000	510	<b>KTB0510CS0</b>	19.00

It is recommended to use insulating sheaths KTB0000YF1 with connection braids KTB0000YT1.

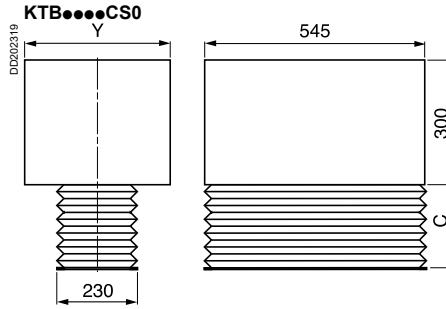

Table of dimensions

Rating (A)	Dimensions (mm)	
	Y	C
800 to 1250	230	200 to 650
1600 to 2500	350	200 to 650
3200 to 4000	510	200 to 650

B

C

D

### Cut-out drawing for fixing the flexible vertical protective cover

E

F

G

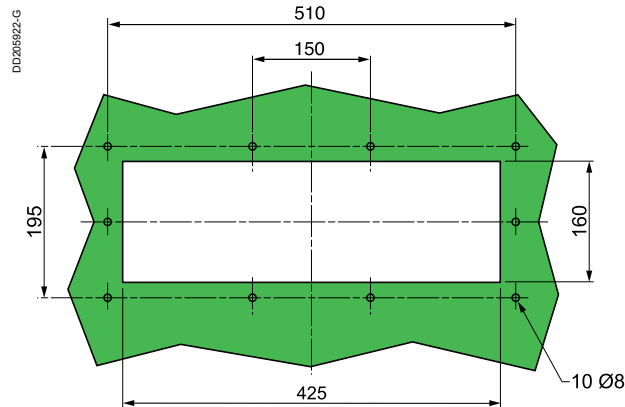

### BC - Cable boxes

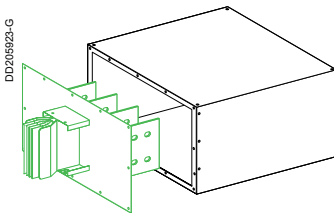

KTB...BC01

Rating (A)	Dimensions "Y" (mm)	Cat. no.	Weight (kg)
800 to 1250	230	<b>KTB0230BC01</b>	15.00
1600 to 2500	350	<b>KTB0350BC01</b>	17.00
3200 to 4000	510	<b>KTB0510BC01</b>	19.00

Cable boxes are only to be used on ER N1 to N6 straight feed units with standard **between centre distances = 115 mm**.

KTB...BC01

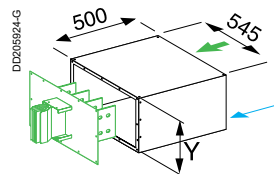

- ← Cable entry.
- ← Aluminium plate to be drilled.

Table of dimensions

Rating (A)	Dimensions (mm)
	Y
800 to 1250	230
1600 to 2500	350
3200 to 4000	510

See table page 85 for connection pad dimensions.

A

B

C

D

E

F

G

# Feed units for dry-type transformers IP55

## Canalis KTA 800 to 4000

### Ordering

Complete the catalogue number by replacing "●●●●" by the rating.

#### Important:

- in the catalogue number for the 800 A rating, add a "0": **KTA0800**
- add the dimensions of the selected unit as a technical comment.

**Example:** the catalogue number of a 3200 A end feed unit, N2, 3L + N + PER, with a between centre distance E = 550 mm, length N = 310 mm and phase order T = 3N21 is:

**KTA3200EL72, E = 550 mm, N = 310 mm and T = 3.**



### EL●1, EL●2 - N1 and N2 feed units for dry-type transformers

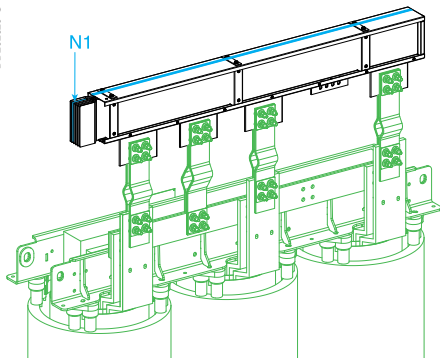

KTA●●●●EL●1

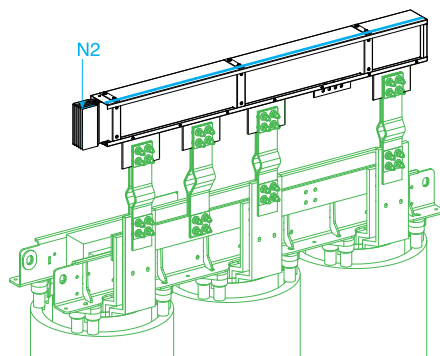

KTA●●●●EL●2

Type	Position of neutral	Cat. no.		
		3L + PE	3L + N + PE <sup>(2)</sup>	3L + N + PER <sup>(1)</sup>
Made to measure	N1	KTA●●●●EL31	KTA●●●●EL41	KTA●●●●EL51
	N2	KTA●●●●EL32	KTA●●●●EL42	KTA●●●●EL52

<sup>(1)</sup> To order the 3L + N + PER version with reinforced Isc, replace KTA●●●●EL5● by KTA●●●●EL7●.

<sup>(2)</sup> To order the 3L + N + PE 2500 A and 3200 A version with reinforced Isc, replace KTA2500EL4● by KTA2500EL6● and KTA3200EL4● by KTA3200EL6●.

For an installation with flat mounted busbar trunking, add angle brackets between the transformer and the feed unit, see page 96.

For fixing supports, see KTB●●●●ZA4 page 106.

#### KTA●●●●EL●1, KTA●●●●EL●2

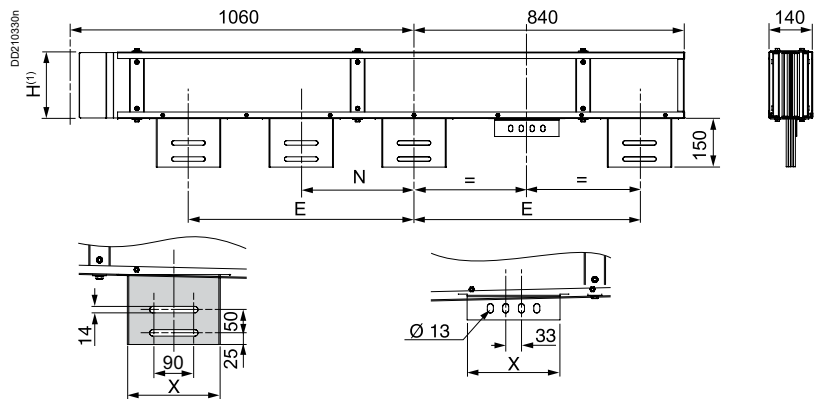

<sup>(1)</sup> See the "Trunking cross-section" table page 99.

#### Table of dimensions

Rating (A)	Neutral	Dimensions (mm)		
		E	N	X
800 to 1250	N1, N2	390 to 700	195 to E - 195	160
1600 to 4000	N1, N2	470 to 700	235 to E - 235	200

### Selecting phase order T

#### Top views

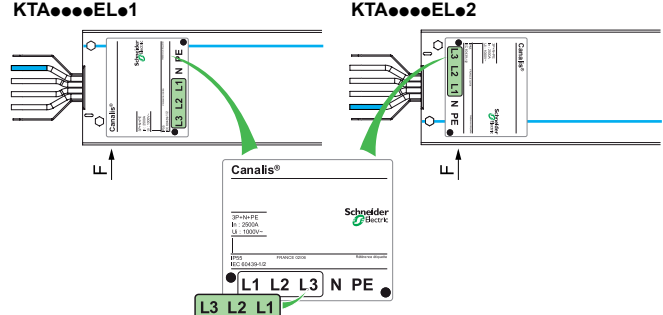
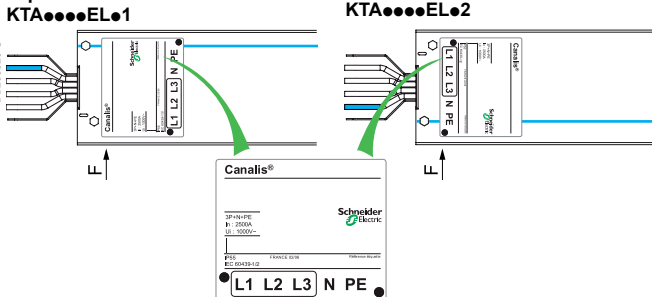

#### Views according to F

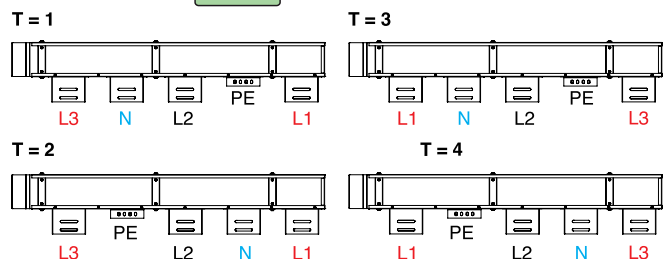
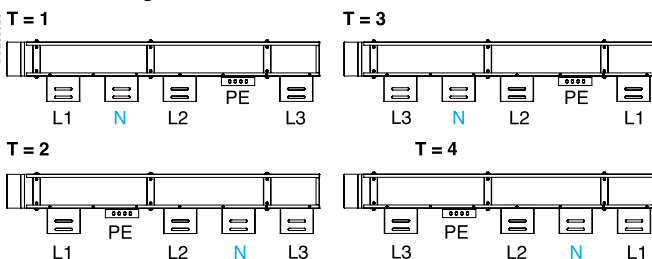

# Catalogue numbers and dimensions

## Feed units for dry-type transformers

### IP55

### Canalis KTA 5000

#### EL<sub>1</sub>, EL<sub>2</sub> - Feed units for dry-type transformers

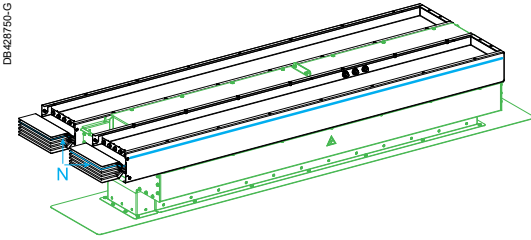

KTA5000EL<sub>1</sub>

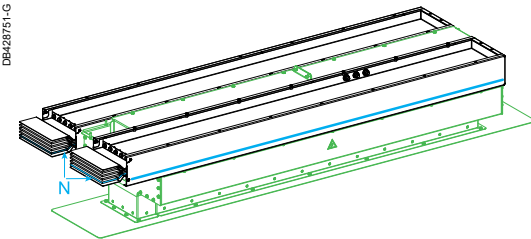

KTA5000EL<sub>2</sub>

Type	Position of neutral	Cat. no.		
		3L + PE	3L + N + PE	3L + N + PER <sup>(1)</sup>
Made to measure	N1	KTA5000EL31	KTA5000EL41	KTA5000EL51
	N2	KTA5000EL32	KTA5000EL42	KTA5000EL52

(1) To order the 3L + N + PER version with reinforced Isc, replace KTA5000EL5<sub>●</sub> by KTA5000EL7<sub>●</sub>.

For an installation with flat mounted busbar trunking, add angle brackets between the transformer and the feed unit, see page 96.  
For fixing supports, see KTB<sub>●●●●</sub>ZA4 page 106.

#### KTA5000EL<sub>1</sub>, KTA5000EL<sub>2</sub>

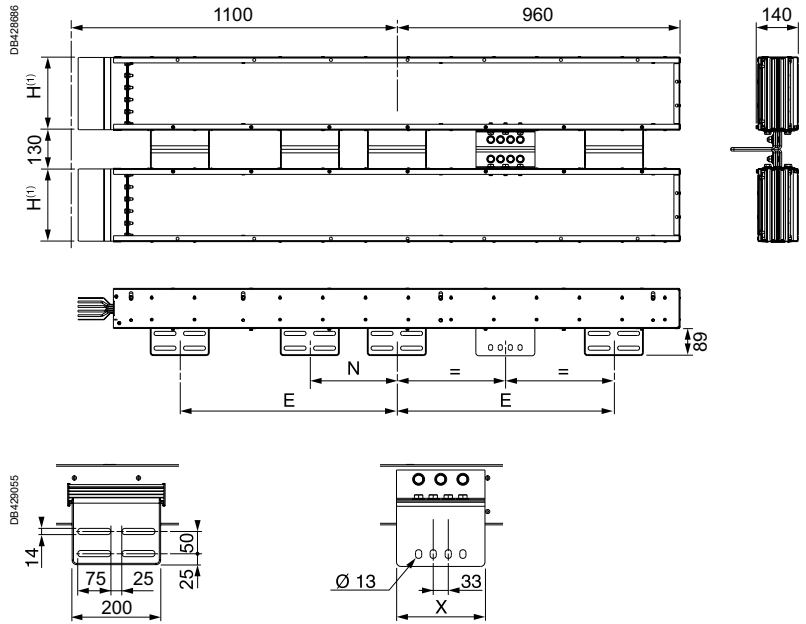

(1) See the "Trunking cross-section" table page 99.

#### Table of dimensions

Rating (A)	Neutral	Dimensions (mm)		
		E	N	X
5000	N1, N2	470 to 736	235 to E - 235	200

### Selecting phase order T

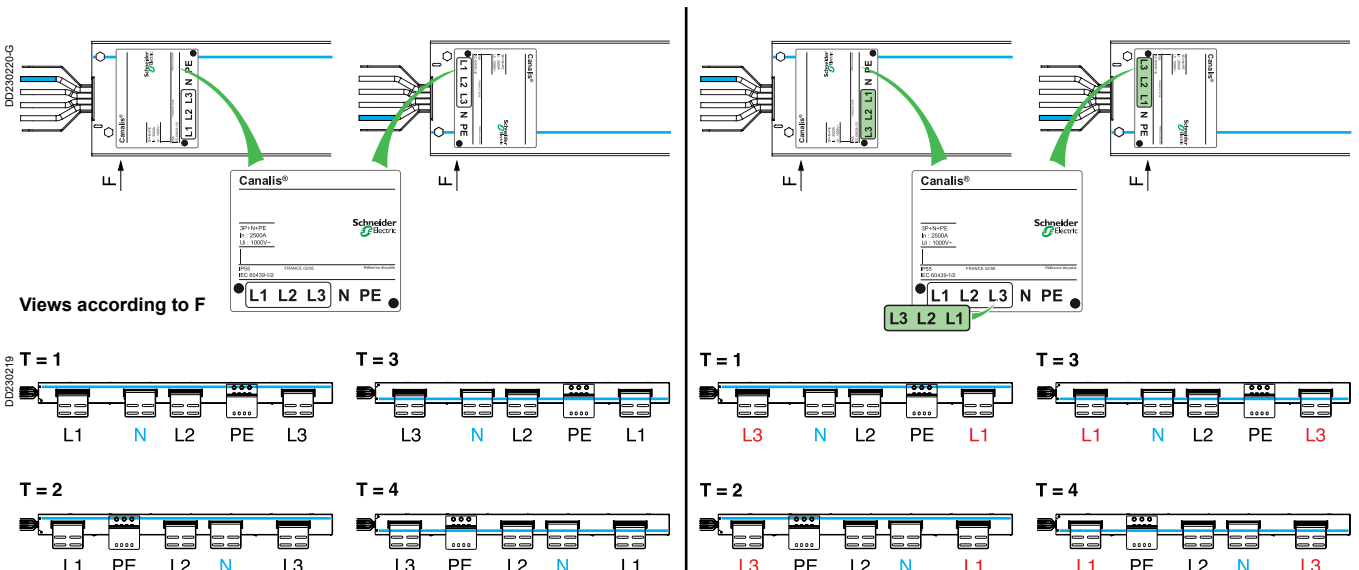

# Feed units for dry-type transformers IP55

## Canalis KTA 800 to 4000

### EL●3, EL●4 - N3 and N4 feed units for dry-type transformers

A

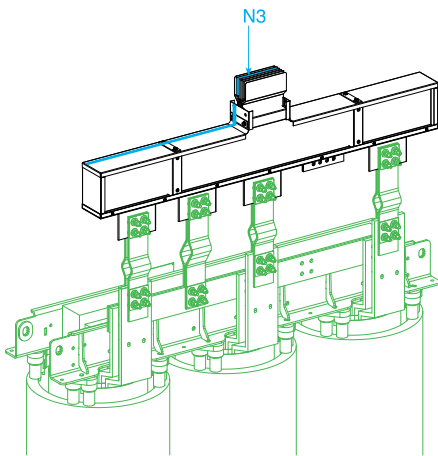

KTA●●●●EL3

B

C

D

E

F

G

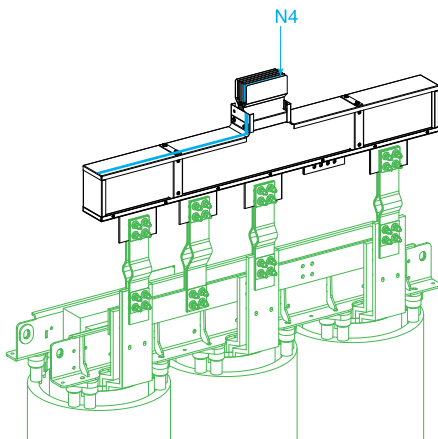

KTA●●●●EL4

Type	Position of neutral	Cat. no.		
		3L + PE	3L + N + PE <sup>(2)</sup>	3L + N + PER <sup>(1)</sup>
Made to measure	N3	KTA●●●●EL33	KTA●●●●EL43	KTA●●●●EL53
	N4	KTA●●●●EL34	KTA●●●●EL44	KTA●●●●EL54

(1) To order the 3L + N + PER version with reinforced Isc, replace KTA●●●●EL5● by KTA●●●●EL7●.

(2) To order the 3L + N + PE 2500 A and 3200 A version with reinforced Isc, replace KTA2500EL4● by KTA2500EL6● and KTA3200EL4● by KTA3200EL6●.

For an installation with flat mounted busbar trunking, add angle brackets between the transformer and the feed unit, see page 96.

For fixing supports, see KTB●●●●ZA4 page 106.

#### KTA●●●●EL3, KTA●●●●EL4

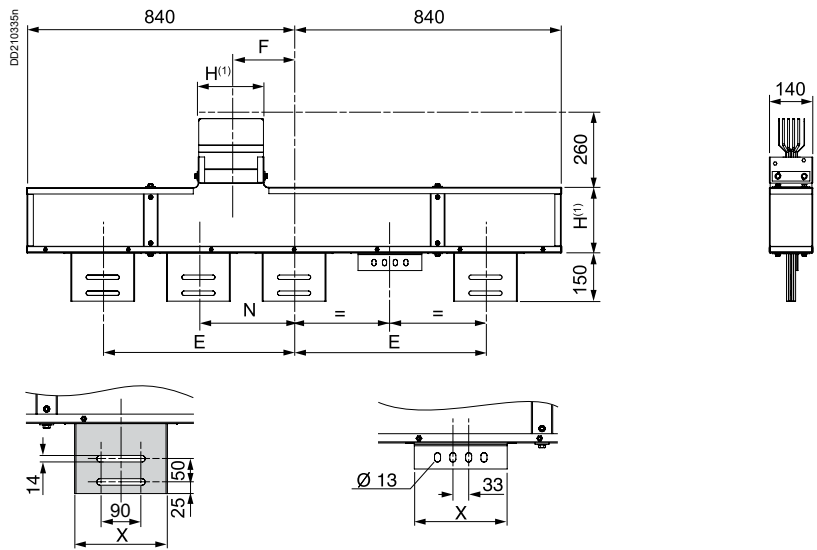

(1) See the "Trunking cross-section" table page 99.

#### Table of dimensions

Rating (A)	Neutral	Dimensions (mm)			
		E	N	F	X
800 to 1250	N3, N4	390 to 700	195 to E - 195	0 to 200	160
1600 to 4000	N3, N4	470 to 700	235 to E - 235	0 to 200	200

### Selecting phase order T

#### Top views

##### KTA●●●●EL3

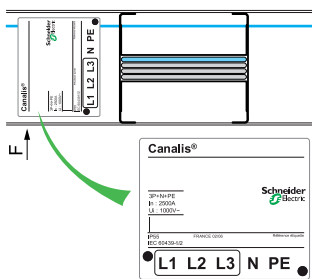

##### KTA●●●●EL4

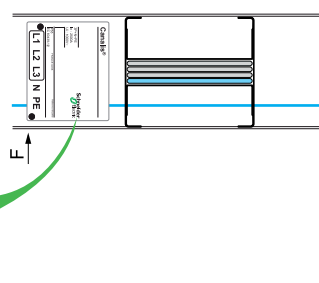

##### KTA●●●●EL3

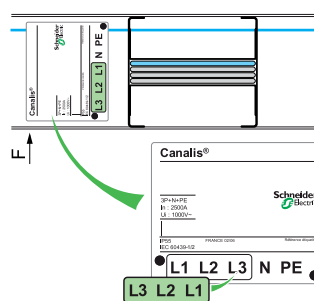

##### KTA●●●●EL4

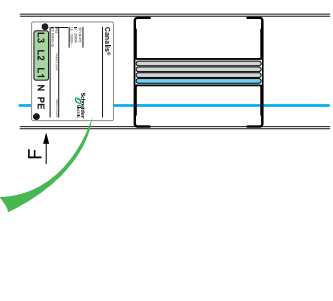

#### Views according to F

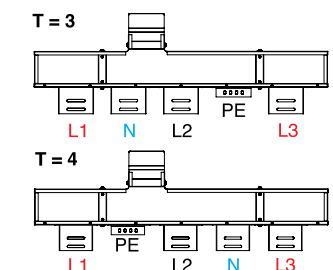
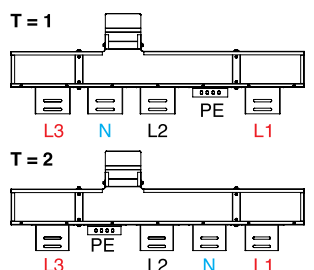
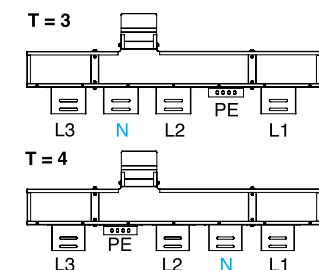
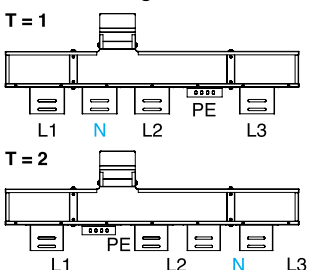

# Catalogue numbers and dimensions

## Feed units for dry-type transformers

### IP55

### Canalis KTA 800 to 5000

#### EL5 - Feed units for dry-type transformers

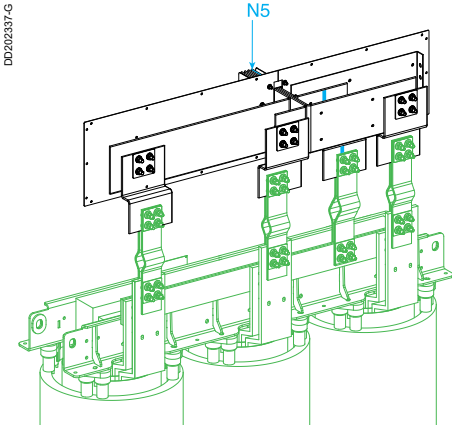

KTA...EL5

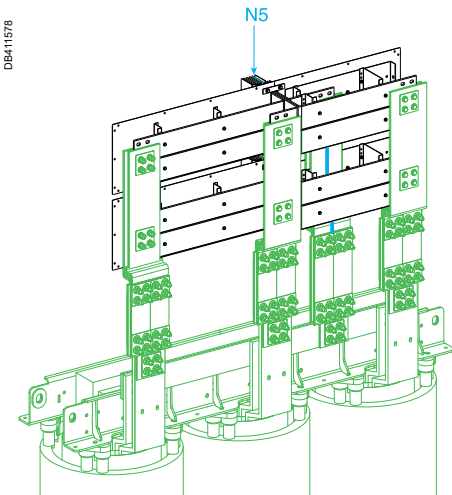

KTA5000EL5

Type	Position of neutral	Cat. no. <sup>(3)</sup>		
		3L + PE	3L + N + PE <sup>(2)</sup>	3L + N + PER <sup>(1)</sup>
Made to measure	N5	KTA...EL35	KTA...EL45	KTA...EL55

(1) To order the 3L + N + PER version with reinforced Isc, replace KTA...EL55 by KTA...EL75.

(2) To order the 3L + N + PE 2500 A and 3200 A version with reinforced Isc, replace KTA2500EL4 by KTA2500EL6 and KTA3200EL4 by KTA3200EL6.

(3) References KTA5000EL5 are made of 2 references KTA2500EL5.

For an installation with flat mounted busbar trunking, add angle brackets between the transformer and the feed unit, see page 96.

These end feed units are supplied with PEN connection kit.

#### KTA...EL5 with a phase order T = 2

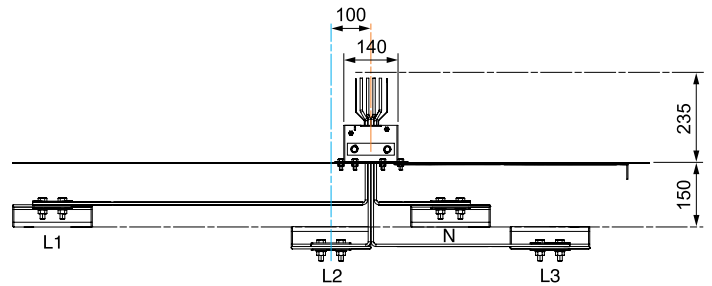
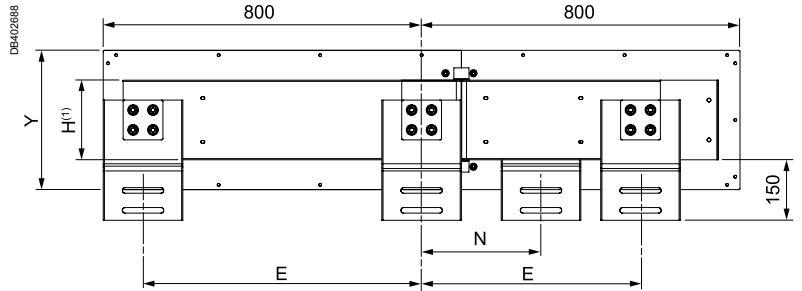

#### KTA...EL5 with a phase order T = 3

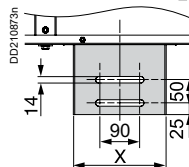
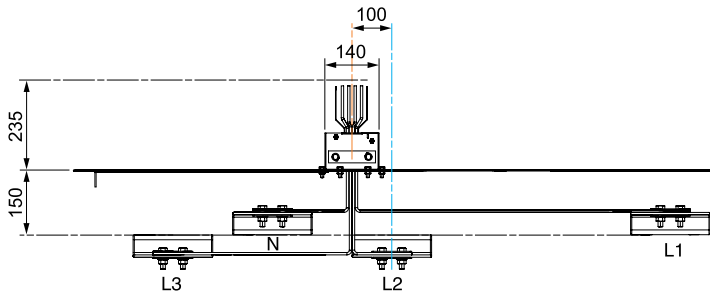
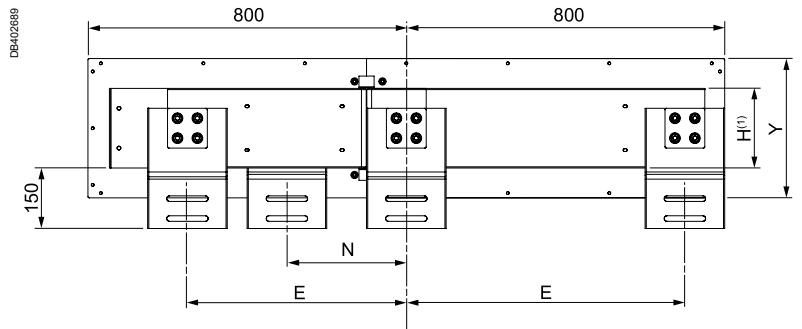

Table of dimensions

Rating (A)	Neutral	Dimensions (mm)			
		Y	E	N	X
800 to 1250	N1, N2	230	390 to 700	195 to E - 195	160
1600 to 2500	N1, N2	350	470 to 700	235 to E - 235	200
3200 to 4000	N1, N2	510	470 to 700	235 to E - 235	200
5000	N5	350	550 to 700	275 to E - 275	200

(1) See the "Trunking cross-section" table page 99.

**Important:** the above designs and markings correspond to a phase order of N321, joint block side. If the phase order on the joint block side is N123, inverse markings L1 and L3 on the transformer side.

# Feed units for dry-type transformers IP55

## Canalis KTA 800 to 4000

### YE - Angle brackets for installing N1 to N5 feed units flat

A

B

C

D

E

F

G

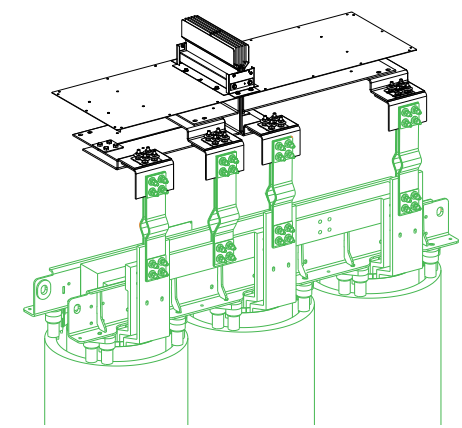
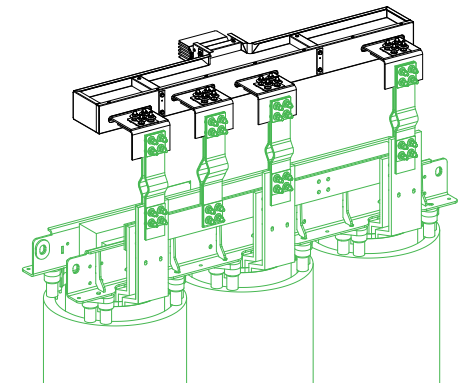
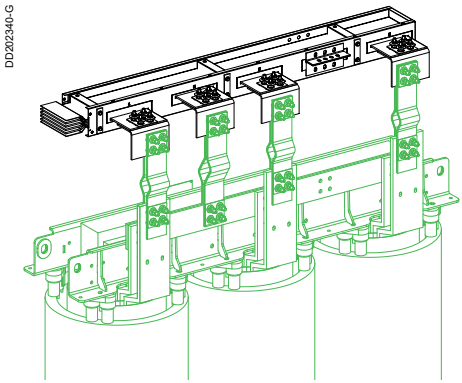

Description	Rating (A)	Phase width "X" (mm)	Cat. no.
4 angle brackets + screws	800 to 1250	160	KTB0000YE1
8 angle brackets + screws	1600 to 2000	200	KTB0000YE21
8 angle brackets + screws	2500	200	KTB0000YE22
12 angle brackets + screws	3200 to 4000	200	KTB0000YE23

KTB0000YE1, KTB0000YE2●

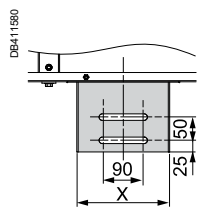
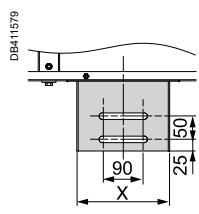
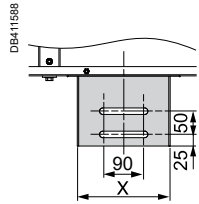

KTB0000YE1/KTB0000YE21

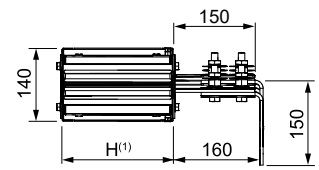

KTB0000YE22

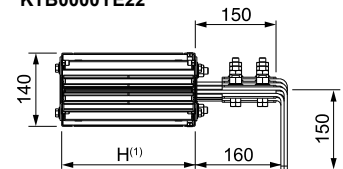

KTB0000YE23

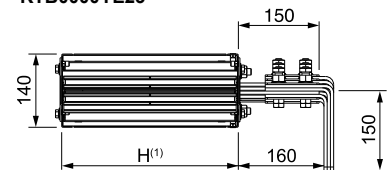

Note: YE angle brackets are made of bare copper.

KTB0000YE1, KTB0000YE21

# Catalogue numbers and dimensions

## Protective covers for dry-type transformers

### IP55

### Ordering

There is no need to add technical comments to the catalogue number ordered.

#### CR4 - Adjustable vertical protective covers for EL, N1 to N4 feed units, edgewise mounting

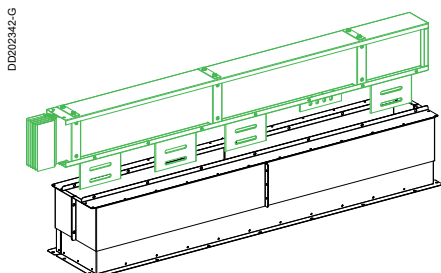

**KTB0000CR4**

Type	Position of neutral	Cat. no.	Weight (kg)
Vertical cover	N1, N2, N3 and N4	<b>KTB0000CR4</b>	24.00

**KTB0000CR4**

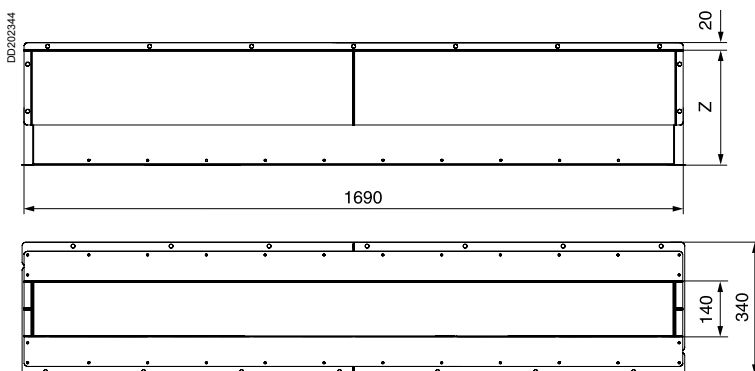
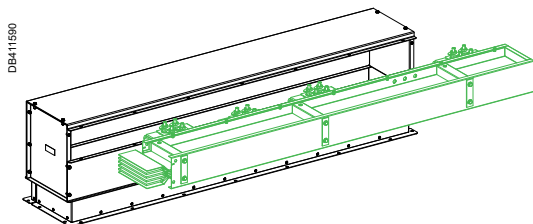

Table of dimensions

Rating (A)	Dimensions Z (mm)	
	Minimum	Maximum
800 to 1250	200	350
1600 to 2500	200	350
3200 to 4000	200	350

#### CR5 - Adjustable horizontal protective covers for EL, N1 to N4 feed units, flat mounting



**KTB0000CR5**

Type	Position of neutral	Cat. no.	Weight (kg)
Horizontal cover	N1, N2, N3 and N4	<b>KTB0000CR5</b>	32.00

**KTB0000CR5**

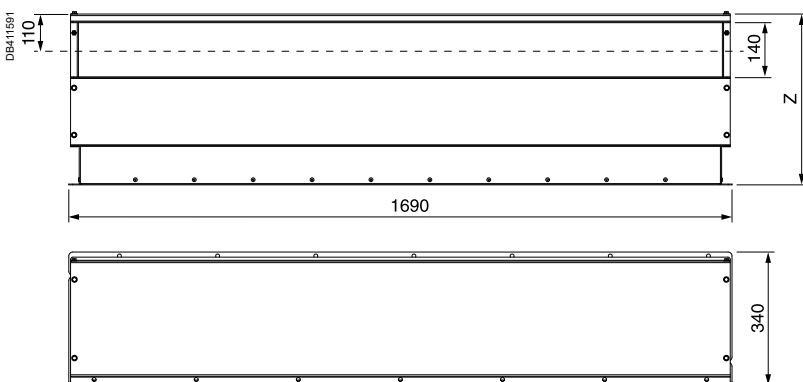

Table of dimensions

Rating (A)	Dimensions Z (mm)	
	Minimum	Maximum
800 to 1250	370	520
1600 to 2500	370	520
3200 to 4000	370	520

# Protective covers for dry-type transformers IP55

## Canalis KTA 800 to 4000

### CR6 - Horizontal protective covers for dry-type transformer N5 feed units

A

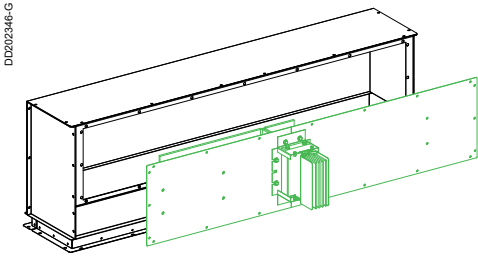

KTB...CR6

B

C

D

E

F

G

Type	Position of neutral	Dimension "Y" (mm)	Cat. no.	Weight (kg)
Horizontal covers	N5	230	KTB0230CR6	38.00
		350	KTB0350CR6	40.00
		510	KTB0510CR6	47.00

#### KTB...CR6

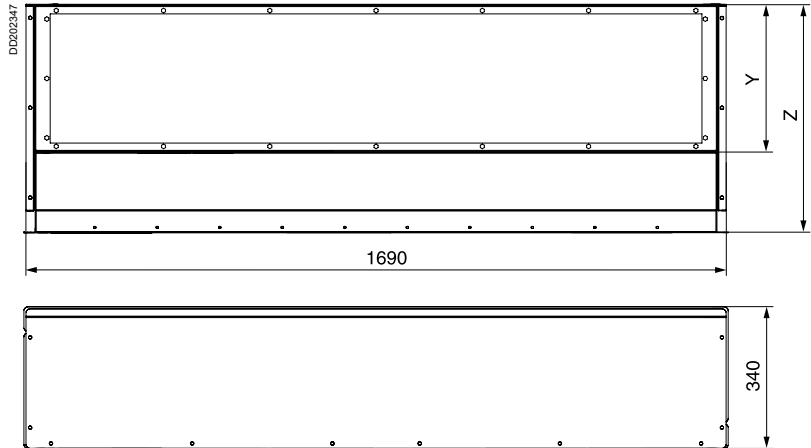
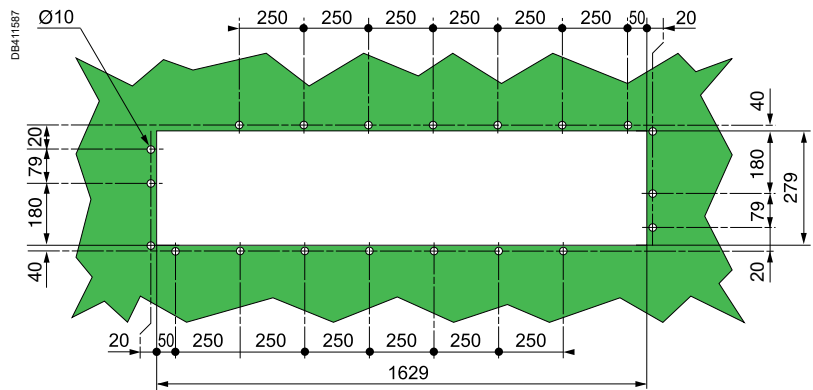

Table of dimensions

Rating (A)	Dimensions (mm)		
	Y	Z	
		Minimum	Maximum
800 to 1250	230	380	530
1600 to 2500	350	500	650
3200 to 4000	510	660	810

### Cut-out drawing for dry-type transformer feed units



View from the top of the transformer.

# Catalogue numbers and dimensions

## Protective covers for dry-type transformers

### IP55

### Canalis KTA 5000

#### CR5 - Adjustable horizontal protective covers for EL, N1 and N2 feed units, flat mounting

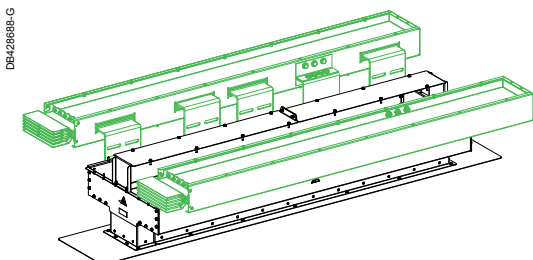

KTB0001CR5

Type	Position of neutral	Cat. no.	Weight (kg)
Horizontal cover	N1, N2	KTB0001CR5	60.00

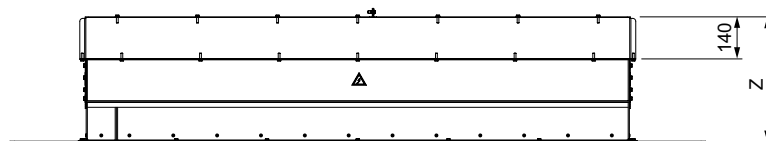
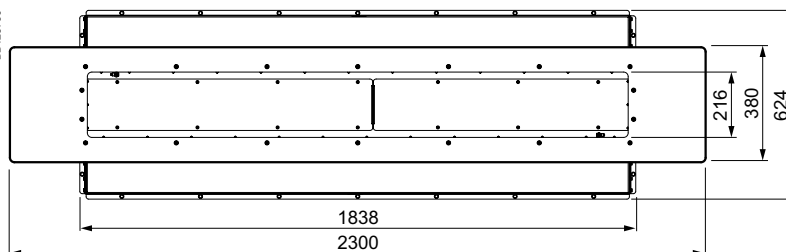
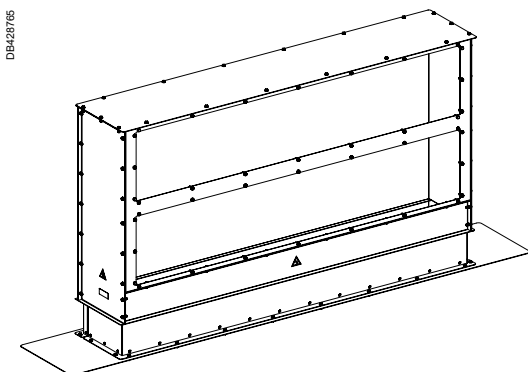

Table of dimensions

Rating (A)	Dimensions Z (mm)	
	Minimum	Maximum
5000	330	480

See "Connection to Trihal cast resin transformers", page 228.

#### CR6 - Adjustable horizontal protective covers for EL, N5 feed units, flat mounting



KTB0001CR6

Type	Cat. no.	Weight (kg)
Horizontal cover	KTB0001CR6	60.00

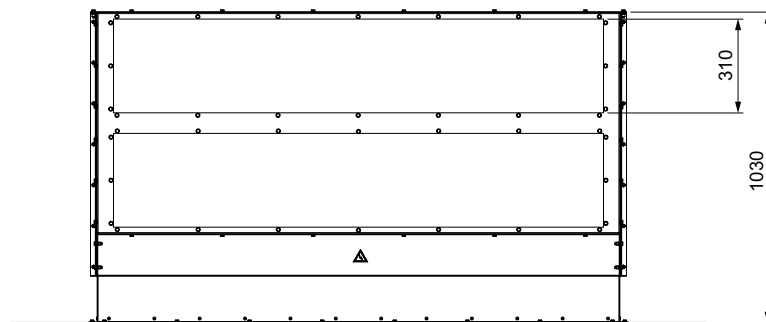
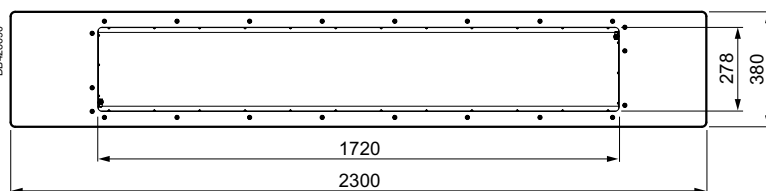

#### Trunking cross-section

Rating (A)	800 <sup>(1)</sup>	1000	1250	1600	2000	2500	3200	4000	5000
Weight (kg/m)									
	3L + PE	12	14	16	19	22	25	31	38
	3L + N + PE	13	16	18	22	26	30	37	45
	3L + N + PER	15	19	21	26	31	36	46	56

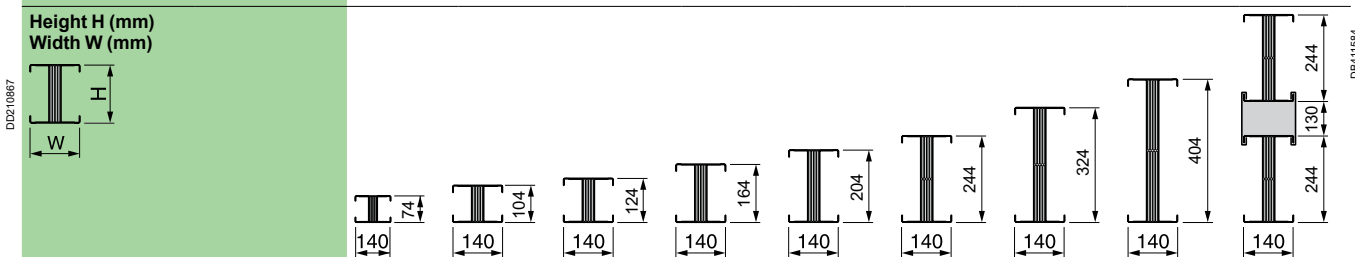

(1) Important: for the 800 A rating, indicate "KTA0800".

### Canalis KTA 800 to 5000

A

#### Ordering

To order YC1 or YC3 flexibles with customized drilled holes at the bottom.

**Example:** total length = 565 mm with a pattern of 4 centred holes 50x50 at 25 mm of the bottom.

**KTB0100YC305B, L=565, A=50, B=25, C=25, D=50, E=2, F=2, Y=25.**

B

To order flexibles without drilled holes at the bottom.

**Example:** total length = 435 mm.

**KTB0100YC305B, L=435, E=0, F=0, Y=25.**

In all cases E, F and Y need to be filled.

C

#### YC1 - Connection plates

Type	Surface treatment	"Width (mm) W"	"Depth (mm) T"	"Length (mm) L"	Cross-section (mm <sup>2</sup> )	Cat. no.	Weight (kg)
Made to measure	Bi-metal aluminium copper <sup>(3)</sup>	100	7	300 to 600	700 <sup>(1)</sup>	<b>KTB0100YC107A</b>	1.6
		120	7	300 to 600	840 <sup>(1)</sup>	<b>KTB0120YC107A</b>	1.9
	Bare copper <sup>(3)</sup>	100	5	300 to 600	500 <sup>(2)</sup>	<b>KTB0100YC105B</b>	2.7
		120	5	300 to 600	600 <sup>(2)</sup>	<b>KTB0120YC105B</b>	3.2

(1) Made of 5 sheets of 1.4 mm (16 % CU, 84 % AL).

(2) Made of 5 sheets 1 mm (100 % CU).

(3) The number of bi-metal aluminium copper connections per phase is the same as bare copper.

**Note:** 2 (100 x 5) bare copper can be replaced by 2 (100 x 7) bi-metal aluminium copper.

D

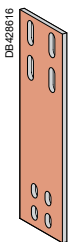

**KTB0100YC107A**  
Bi-metal aluminium copper

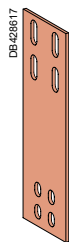

**KTB0100YC105B**  
Bare copper

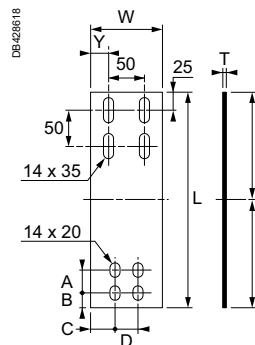

#### Dimensions

##### Dimensions (mm)

L \_\_\_\_\_

A \_\_\_\_\_

B \_\_\_\_\_

C \_\_\_\_\_

D \_\_\_\_\_

E \_\_\_\_\_

F \_\_\_\_\_

Y \_\_\_\_\_

- E = number of vertical holes (bottom pattern)
- F = number of horizontal holes (bottom pattern)

E

F

G

#### YC3 - Connection flexible links with onde

Type	Surface treatment	"Width (mm) W"	"Depth (mm) T"	"Length (mm) L"	Cross-section (mm <sup>2</sup> )	Cat. no.	Weight (kg)
Made to measure	Bi-metal aluminium copper <sup>(3)</sup>	100	7	300 to 600	700 <sup>(1)</sup>	<b>KTB0100YC307A</b>	1.6
		120	7	300 to 600	840 <sup>(1)</sup>	<b>KTB0120YC307A</b>	1.9
	Bare copper <sup>(3)</sup>	100	5	300 to 600	500 <sup>(2)</sup>	<b>KTB0100YC305B</b>	2.7
		120	5	300 to 600	600 <sup>(2)</sup>	<b>KTB0120YC305B</b>	3.2

(1) Made of 5 sheets of 1.4 mm (16 % CU, 84 % AL).

(2) Made of 5 sheets 1 mm (100 % CU).

(3) The number of bi-metal aluminium copper connections per phase is the same as bare copper.

**Note:** 2 (100 x 5) bare copper can be replaced by 2 (100 x 7) bi-metal aluminium copper.

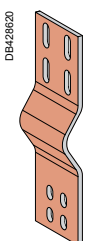

**KTB0100YC307A**  
Bi-metal aluminium copper

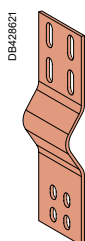

**KTB0100YC305B**  
Bare copper

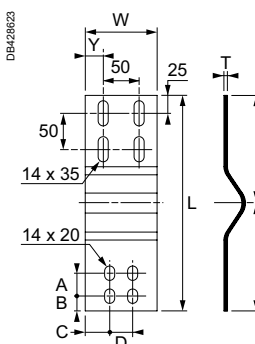

#### Dimensions

##### Dimensions (mm)

L \_\_\_\_\_

A \_\_\_\_\_

B \_\_\_\_\_

C \_\_\_\_\_

D \_\_\_\_\_

E \_\_\_\_\_

F \_\_\_\_\_

Y \_\_\_\_\_

- E = number of vertical holes (bottom pattern)
- F = number of horizontal holes (bottom pattern)

Connection selection guide:  
refer page 232 for cast resin transformer,  
refer page 236 and page 238 for Minera immersed transformer

### YC5 - Connection insulated

Type	Surface treatment	"Width (mm) W"	"Depth (mm) T"	"Length (mm) L"	Cross-section (mm <sup>2</sup> )	Cat. no.	Weight (kg)
Fixed, insulated	Bi-metal aluminium copper <sup>(3)</sup>	100	7	1000	700 <sup>(1)</sup>	<b>KTB0100YC50710A</b>	2.6
		100	7	600	700 <sup>(1)</sup>	<b>KTB0100YC50706A</b>	1.6
	Bare copper <sup>(3)</sup>	100	5	1000	500 <sup>(2)</sup>	<b>KTB0100YC50510B</b>	4.5
		100	5	600	500 <sup>(2)</sup>	<b>KTB0100YC50506B</b>	2.7

(1) Made of 5 sheets of 1.4 mm (16 % CU, 84 % AL).

(2) Made of 5 sheets 1 mm (100 % CU).

(3) The number of bi-metal aluminium copper connections per phase is the same as bare copper.

**Note:** 2 (100 x 5) bare copper can be replaced by 2 (100 x 7) bi-metal aluminium copper.



**KT B0100YC507**  
Insulated, bi-metal aluminium copper



**KT B0100YC505**  
Insulated, bare copper

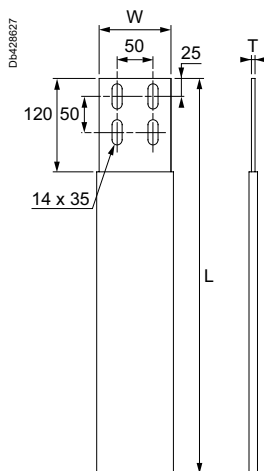

Connection selection guide:  
refer page 232 for cast resin transformer,  
refer page 236 and page 238 for Minera immersed transformer



### Canalis KTA 800 to 5000

#### YT - Braids

A

B

C

D

E

F

G



KTB0000YT1

Description	Cat. no.	Weight (kg)
Connection braid	KTB0000YT1	2.80

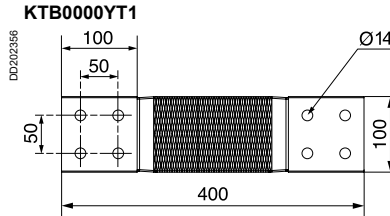

#### Determining the number of braids required

Busbar trunking rating (A)	Braids per phase	
	Number	Cross-section (mm <sup>2</sup> )
1000	1	600
1250	2	1200
1600	2	1200
2000	2	1200
2500	3	1800
3200	3	1800
4000	4	2400
5000	6	3600

Braids	1	1 1	1 2	2 2	3 3
Busbar trunking rating (A)	1000	1250 to 2000	2500 to 3200	4000	5000



### YF - Insulating sheaths

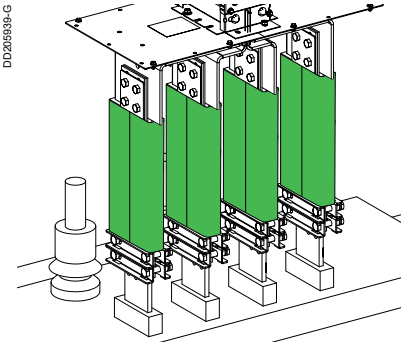

KTB0000YF1

The YF conduit allows the various conductors of a connection performed with braids or with bare copper foils to be insulated. Installation is performed after complete assembly of the connection, with scratch fastening for easier setup. The insulating conduit is formed of a 2-metre plastic duct that can be cut to length as needed.

Désignation	Cat. no.	Weight (kg)
Insulating sheath	KTB0000YF1	1.00

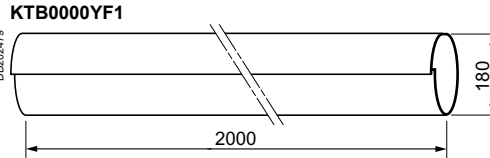

### YB - Spacers and bolts

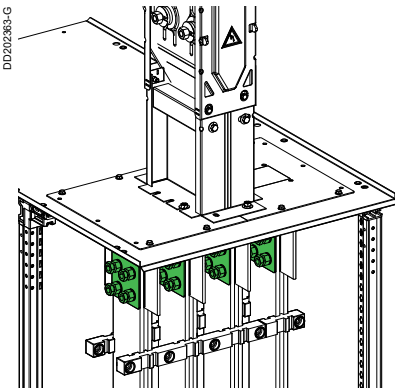

KTB0000YB2

Description		Cat. no.	Weight (kg)
<b>Connection torque nut kit</b>	1 torque nut + 2 flat washers (Ø 60) + 1 elastic washer (Ø 55)	KTB0000YB1	-
<b>Spacers for direct connection</b>	8 x 3 mm galvanized steel plates + 8 x 2 mm copper spacers + 16 x M12 x 60 bolts + washers and nuts	KTB0000YB2	5.50
<b>Spacer plates for connector plate connections</b>	8 x 3 mm galvanized steel plates + 16 x M12 x 60 bolts + washers and nuts	KTB0000YB3	4.00
	8 x 3 mm galvanized steel plates + 16 x M12 X 80 bolts + washers and nuts	KTB0000YB4	4.00
<b>Set of bolts</b>	16 x M10 x 60 bolts + washers and nuts	KTB0000YB5	2.00

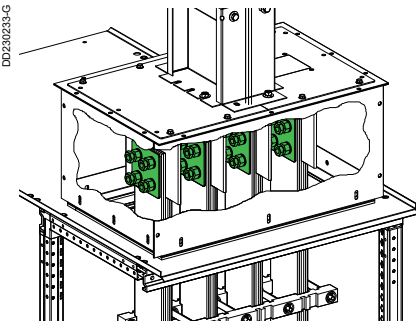

KTB0000YB3

Copper spacer

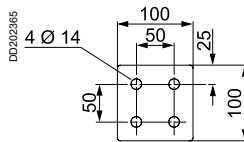

Galvanized steel spacer plates

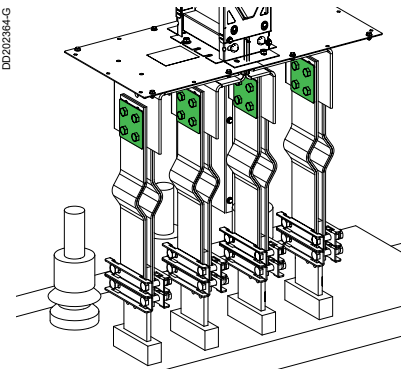
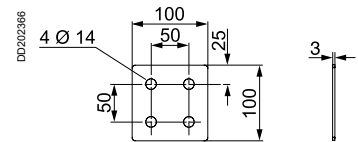

KTB0000YB4

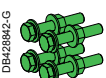

KTB0000YB5

### Canalis KTA 800 to 5000

#### YS - Bar supports

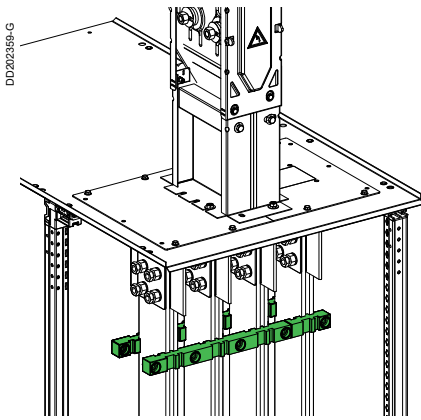

Description	Cat. no.	Weight (kg)
Bar support, 115 mm between centres for bar of 2x5 or 10 mm	KTB0000YS1	2.40

KTB0000YS1

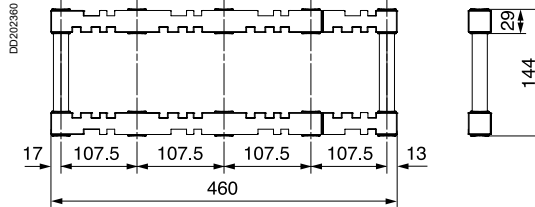

KTB0000YS1

#### YS - Bar clamps

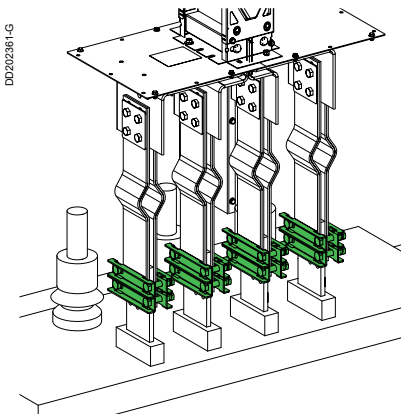

Description	Dimensions of transformer connection terminals (mm)	Cat. no.	Weight (kg)
8 bar clamps	100	KTB0000YS2	6.40
	120	KTB0000YS3	6.40

Each bar clamp includes 2 cross members and associated fixings.

KTB0000YS2

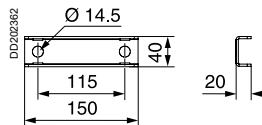

KTB0000YS3

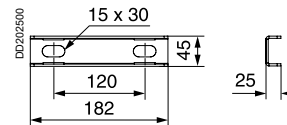

KTB0000YS●

#### YP1 - Connection plate for oil immersed Minera transformer

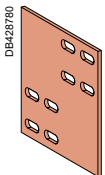

KTB0000YP1●

##### Type YP1

Plates for Minera oil transformer, connection from the top.  
The product reference is for one phase.  
Bolts at the equipments level are not included in the reference.  
See selection table page 239.

A (mm)	B (mm)	H (mm)	W (mm)	X (mm)	Y (mm)	Cat. no.	Weight (kg)
20	28	200	200	28	20	KTB0000YP11	2.1
20	38	200	200	38	20	KTB0000YP12	2.1
20	28	200	260	28	20	KTB0000YP13	2.8
25	25	200	200	25	21	KTB0000YP14	2.1

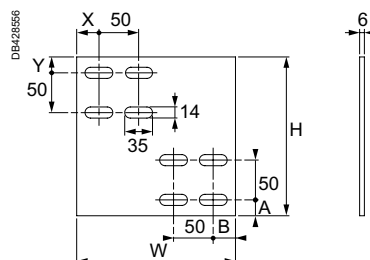

### Canalis KTA 5000

#### YP2 - Connection plates for KTA5000 end feed units

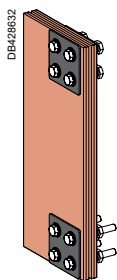

**KTB0000YP21**

#### Type YP21 for ER1 to ER6 horizontal inco

Plates to link connection pads of 2 end feed units KTA2500 (ER1 to ER6) in order to create a KTA5000.

Link to transformer or switchboard has to be connected at the lowest 4 bolts system.

The product reference is for one phase and includes screws, nuts and washers at the busbar trunking side.

Bolts at the transformer or switchboard level are not included in the reference.

	Cat. no.	Weight (kg)
1 set of plates and bolts for 1 phase	<b>KTB0000YP21</b>	21

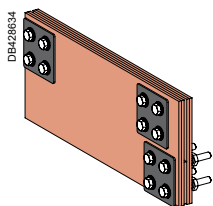
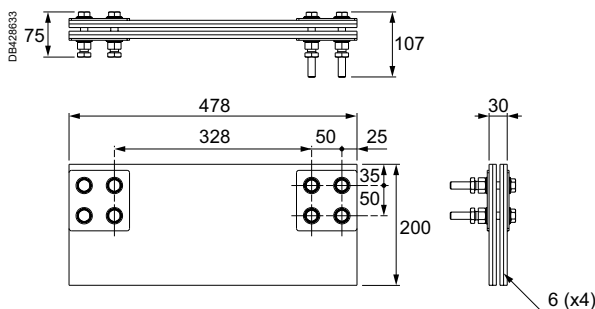

**KTB0000YP22**

#### Type YP22 for ER1 to ER6 vertical inco

Plates to link connection pads of 2 end feed units KTA2500 (ER1 to ER6) in order to create a KTA5000.

The product reference is for one phase and includes screws, nuts and washers at the busbar trunking side.

Bolts at the transformer or switchboard level are not included in the reference.

	Cat. no.	Weight (kg)
1 set of plates and bolts for 1 phase	<b>KTB0000YP22</b>	24.5

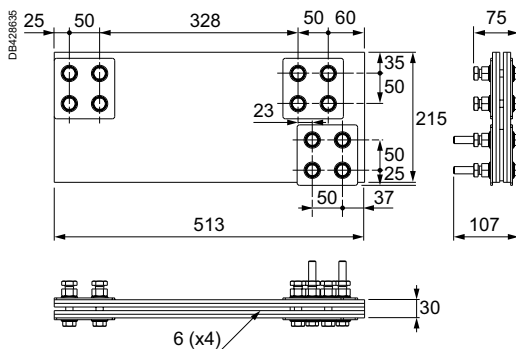

### Canalis KTA

#### ZA1, ZA4 - Supports for edge wise horizontal installation

A

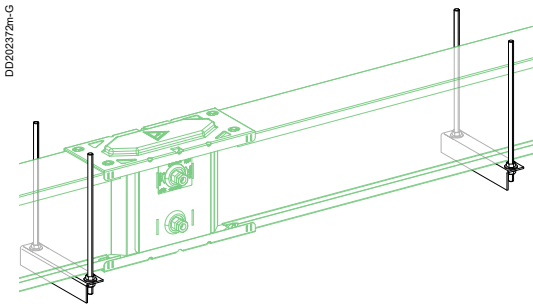

Description	Rating (A)	Busbar trunking height (mm)	Cat. no.	Weight (kg)
1 support from the bottom (threaded rods supplied) <sup>(1)</sup>	-	-	KTB0000ZA1	2.80
Set of 2 supports from the top (threaded rods not supplied)	800	74	KTB0074ZA4	3.20
	1000 to 4000	104 to 404	KTB0404ZA4	3.80

B

C

KTB0000ZA1

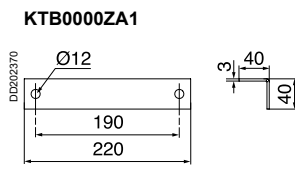

D

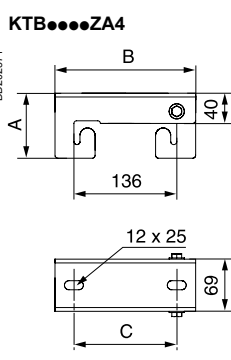
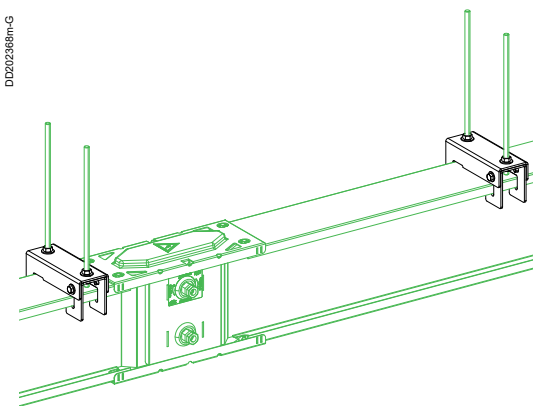

Table of dimensions

Height "H" (mm)	Dimensions (mm)		
	A	B	C
74	74	160	110
104 to 404	86	186	136

E

F

KTB...ZA4

(1) Threaded rods, length = 2 metres, are supplied with the support.

#### ZA3 - Hooks for edge wise horizontal installation

G

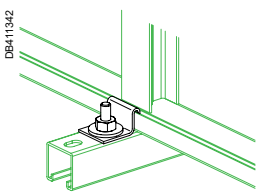

2 fixing grips are needed for each fixing point.

Description	Cat. no.	Weight (kg)
1 set of 8 hooks	KTB0000ZA3	0.60

KTB0000ZA3

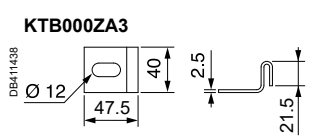

A

B

C

D

E

F

G

### ZA7 - Supports for flat wise horizontal installation (41 x 41)

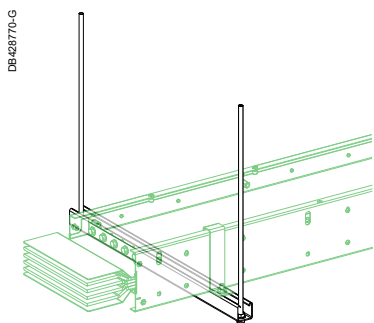

KTB●●●●ZA7

Busbar trunking rating (A)	Busbar trunking height "H" (mm)	Length L (mm)	Cat. no.	Weight (kg)
800 to 1250 <sup>(1)</sup>	74, 104, 124	280	KTB0124ZA7	0.6
1600 to 2000 <sup>(1)</sup>	164, 204	350	KTB0204ZA7	0.7
2500 <sup>(1)</sup>	244	420	KTB0244ZA7	0.9
3200 <sup>(1)</sup>	324	490	KTB0324ZA7	1
4000 <sup>(1)</sup>	404	560	KTB0404ZA7	1.2
5000 <sup>(1)</sup>	622	770	KTB0622ZA7	1.6
To be customized <sup>(2)</sup>	All	3000	KTB0000ZA7	6.5

(1) Threaded rods, length = 2 meters, are supplied with the support.  
 (2) Threaded rods not supplied.

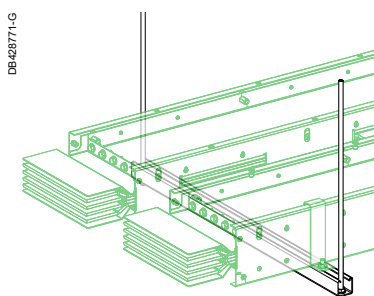

KTB0622ZA7

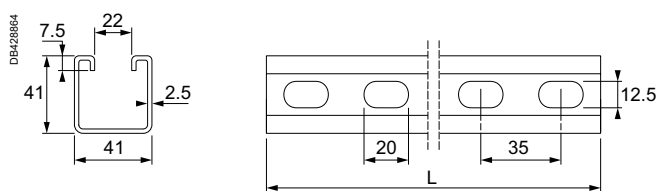

### ZA8 - Bracket for flat wise horizontal installation

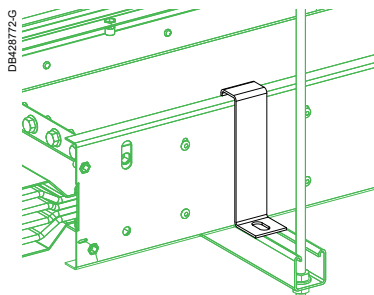

KTB0000ZA8

2 brackets are needed for each fixing point.

Description	Cat. no.	Weight (kg)
1 set of 8 brackets	KTB0000ZA8	0.14

Supplied with a spacer for fixation of KT●●●●ED●●●●.  
 T-bolts are not supplied with this reference.

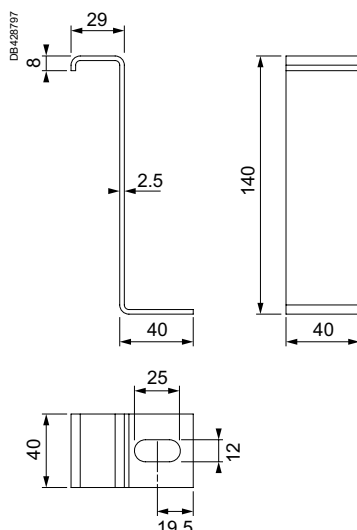

### YB6 - T-Bolts

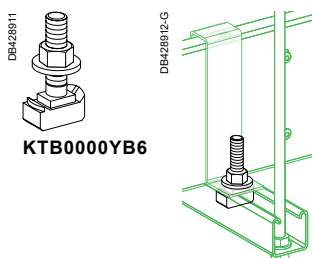

KTB0000YB6

Description	Cat. no.	Weight (kg)
1 box of 50 bolts M10 x 35 for rails 41 x 41	KTB0000YB6	6.0

Includes T-screws, nuts and washers.

### Canalis KTA

#### ZA5 - Vertical supports

- A
- B
- C
- D
- E
- F
- G

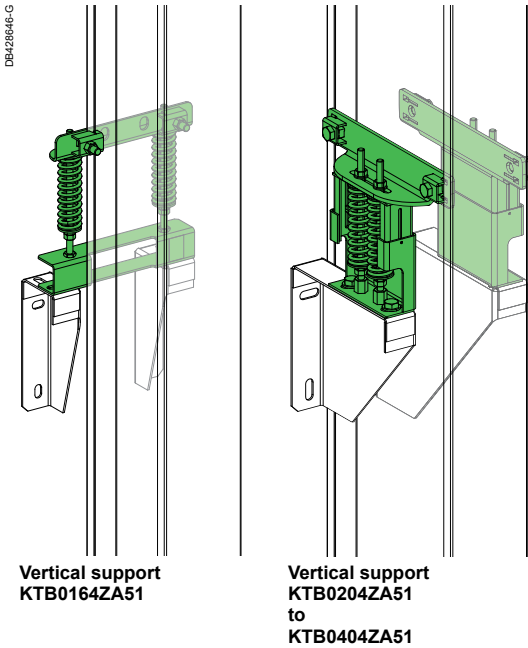

Description	Rating (A)	Busbar trunking height (mm)	Vertical support		Wall bracket	
			Cat. no.	Weight (kg)	Cat. no.	Weight (kg)
Fixings	800 to 1600	74 to 164	KTB0164ZA51	2.1	KTB0164ZA52	2
	2000	204	KTB0204ZA51	6.9	KTB0204ZA52	3.2
	2500	244	KTB0244ZA51	7.1	KTB0244ZA52	3.5
	3200	324	KTB0324ZA51	7.6	KTB0324ZA52	4.2
	4000	404	KTB0404ZA51	8.4	KTB0404ZA52	4.2

For further details, see page 202.

#### KTB0164ZA5●

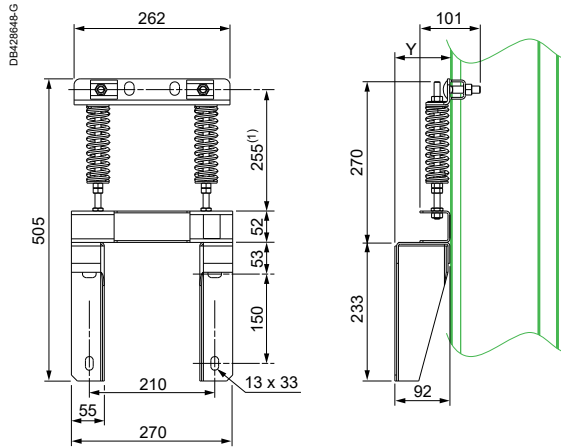

(1) Dimensions with free springs.

#### Table of dimensions

Rating (A)	Dimensions "Y" (mm)
All	50 < Y < 100

#### KTB0204ZA5● to KTB0404ZA5●

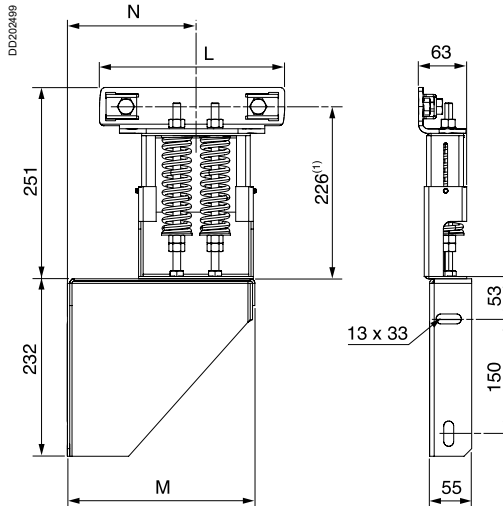

(1) Dimensions with free springs.

#### Table of dimensions

Rating (A)	Dimensions (mm)		
	L	M	N
2000	202	205	152 to 202
2500	240	245	172 to 222
3200	322	325	212 to 262
4000	402	325	252 to 302

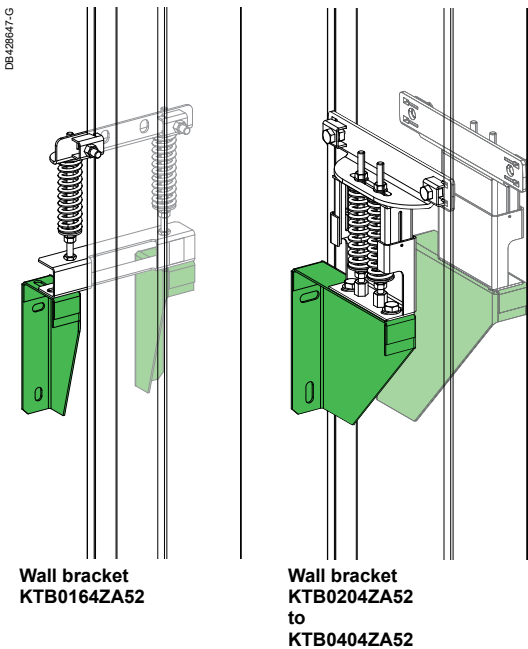

#### Trunking cross-section

Rating (A)	800 <sup>(1)</sup>	1000	1250	1600	2000	2500	3200	4000	5000
Height H (mm)	74	104	124	164	204	244	324	404	244
Width W (mm)	140	140	140	140	140	140	140	140	140

(1) Important: for the 800 A rating, indicate "KTA0800".

#### Canalis KTA 800 to 5000

#### CF - Fire-barrier

DB428803-G

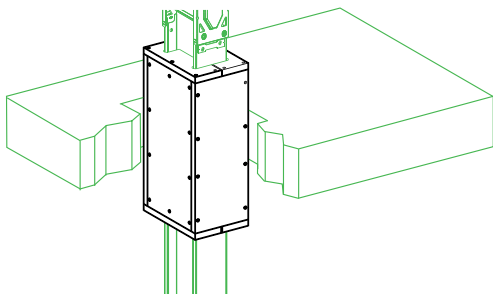

Type	Busbar trunking rating (A)	Busbar trunking height "H" (mm)	Fire barrier length	Cat. no.
Fire-barrier kit	800	74	650	<b>KTB0074CF6</b>
	1000	104	650	<b>KTB0104CF6</b>
	1250	124	650	<b>KTB0124CF6</b>
	1600	164	650	<b>KTB0164CF6</b>
	2000	204	650	<b>KTB0204CF6</b>
	2500	244	650	<b>KTB0244CF6</b>
	3200	324	650	<b>KTB0324CF6</b>
	4000	404	650	<b>KTB0404CF6</b>
	5000	244 X 2	750	<b>KTB0622CF6<sup>(1)</sup></b>

The filler material around the busbar trunking must meet the requirements currently in force to guarantee that the wall and ceiling fire-resistance class (for example DIN 1045 and DIN 1053-1) is maintained.

Filler material not supplied.

(1) This reference includes a sealant cartridge KTB0000SC1.

DB404826

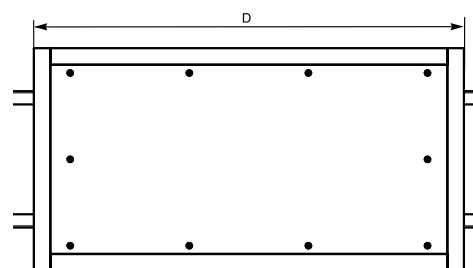
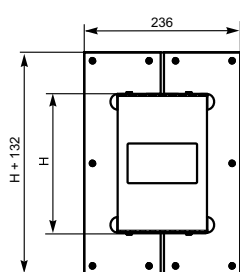

The fire barrier kit can also be made up on site by the installer according to Schneider Electric's drawings and specifications. For further information, consult your sales office.

DB428889-G

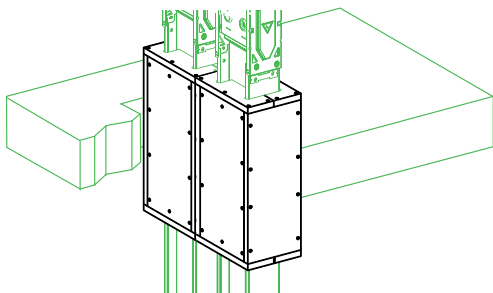

KTB0622CF6

DB428890

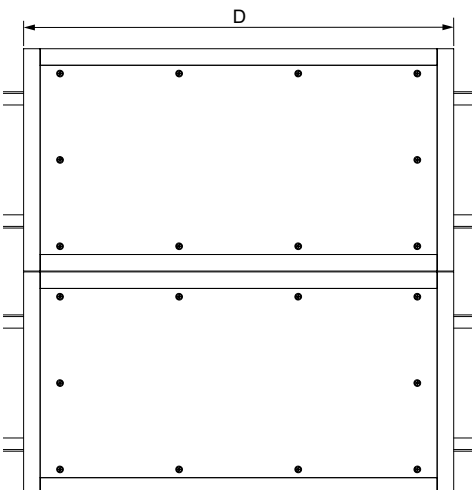
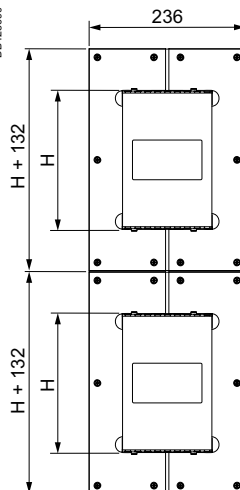

#### SC - Fire-barrier sealant cartridge

DB423006



KTB0000SC1

Type	Cat. no.
Fire-barrier sealant cartridge	<b>KTB0000SC1</b>

# Catalogue numbers and dimensions

## Plug-in tap-off units (for Canalis KT Only)

### For Modular devices

#### Canalis KTA

#### Tap-off units with isolator, not equipped

Disconnection by opening the tap-off unit cover

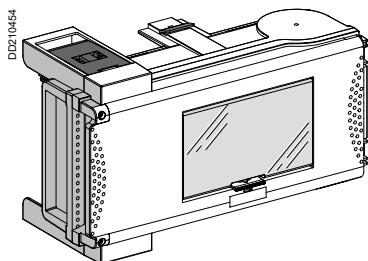

KSB63SM●8,  
KSB100SM●12

Tap-off unit disconnection by opening or closing the cover should be carried out only if the downstream load is de-energised.

System earthing arrangement	Busbar trunking	TT-TNS-TNC-IT <sup>(1)</sup> TNC	
	Tap-off unit	TT-TNS-TNS-IT <sup>(1)</sup> TNC	
Tap-off polarity		3L + N + PE <sup>(2)</sup>	3L + PEN
Tap-off diagram (e.g. circuit breaker protection)			

Rating (A)	Number of 18 mm modules <sup>(3)</sup>	Connection	Max. size (mm <sup>2</sup> )		Cable gland (not supplied)	Cat. no.	Cat. no.	Weight (kg)
			Flexible	Rigid				
63 <sup>(5)</sup>	8	On devices	16	16	ISO 50 max.	<b>KSB63SM48</b>	<b>KSB63SM58</b>	2.40
100 <sup>(5)</sup>	12	On devices	35	35	ISO 63 max.	<b>KSB100SM412</b>	<b>KSB100SM512</b>	5.00

- (1) The neutral must be protected or not distributed (3L + PE) for the IT system.
- (2) Also suitable for tap-off unit 3L + PE (N not distributed, IT system also possible).
- (3) Supplied with blanking plates: 1x5 divisible (8 modules) or 2x5 divisible (12 modules).
- (4) Maximum diameter for a multipolar cable.
- (5) IP55 Rating.

#### KSB63SM●8, KSB100SM●12

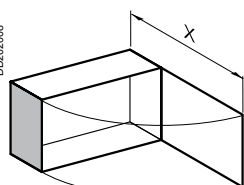

X = 432.5 (KSB63SM●8)  
X = 545.5 (KSB100SM●12)

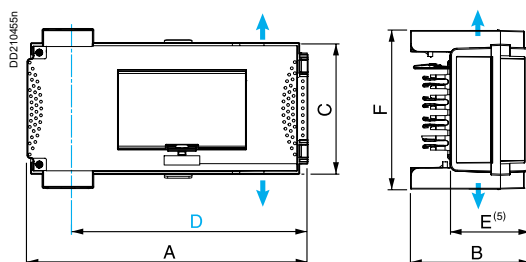

- Cable exit
- Centre line of tap-off outlets

(5) Protruding

Dimensions	Rating (A)	
	63	100
A	357	444
B	158	183
C	167	202
D	309	397
E	108	133
F	202	220

# Catalogue numbers and dimensions

## Plug-in tap-off units

### For Modular devices



#### Tap-off units for NG modular devices, not equipped

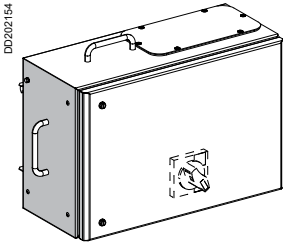

**KSB160SM•13**

The cover of the tap-off unit may be opened or closed only when the circuit breaker is in the Off position.

System earthing arrangement	Busbar trunking	TT-TNS-TNC-IT <sup>(1)</sup> TNC	
	Tap-off unit	TT-TNS-TNS-IT <sup>(1)</sup> TNC	
Tap-off polarity		3L + N + PE <sup>(2)</sup>	3L + PEN
Tap-off diagram (e.g. circuit breaker protection)			

Rating (A)	Type of circuit-breaker	Connection	Max. size (mm <sup>2</sup> )		Cable gland <sup>(3)</sup> (not supplied)	Cat. no.	Cat. no.	Weight (kg)
			Flexible	Rigid				
160 <sup>(5)</sup>	NG125 Rotary handle 19088 <sup>(4)</sup> NG160 Rotary handle 28060 <sup>(4)</sup>	Terminals	50	70	ISO 25 max.	<b>KSB160SM413</b>	<b>KSB160SM513</b>	8.50

- (1) The neutral must be protected or not distributed (3L + PE) for the IT system.
- (2) Also suitable for tap-off unit 3L + PE (N not distributed, IT system also possible).
- (3) Maximum diameter by unipolar cable.
- (4) Not supplied.
- (5) IP55 Rating.

**KSB160SM•13**

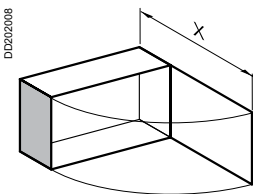

X = 625.5

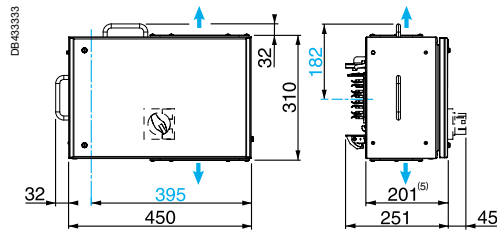

- Cable exit
- Centre line of tap-off outlets
- (5) Protruding

# Catalogue numbers and dimensions

## Plug-in tap-off units

### For Compact NSX circuit breakers

#### Canalis KTA

#### Tap-off units for Compact NSX, fixed, front-connected circuit breakers, not equipped

A

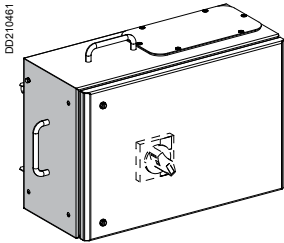

KSB160DC

B

C

D

E

F

G

The cover of the tap-off unit may be opened or closed only when the circuit breaker is in the Off position.

System earthing arrangement	Busbar trunking	TT-TNS-TNC-IT <sup>(1)</sup> TNC
	Tap-off unit	TT-TNS-TNS-IT <sup>(1)</sup> TNC
Tap-off polarity		3L + N + PE <sup>(2)</sup> 3L + PEN
Tap-off diagram (e.g. circuit breaker protection)		

Rating (A)	Type of circuit breaker (Not Supplied)	Connection	Max. size (mm <sup>2</sup> )		Cable gland <sup>(3)</sup> (not supplied)	Cat. no.	Cat. no.	Weight (kg)
			Flexible	Rigid				
160 <sup>(4)</sup>	NSX100 or NSX160 Rotary handle LV429338T	Terminals	50	70	ISO 25 max.	<b>KSB160DC4</b>	<b>KSB160DC5</b>	9.00
250 <sup>(4)</sup>	NSX250 Rotary handle LV429338T	Terminals	70	150	ISO 32 max.	<b>KSB250DC4</b>	<b>KSB250DC5</b>	12.50
400 <sup>(4)</sup>	NSX400 Rotary handle LV429338T	Terminals	150	240	ISO 40 max.	<b>KSB400DC4</b>	<b>KSB400DC5</b>	18.00

- (1) The neutral must be protected or not distributed (3L + PE) for the IT system.
- (2) Also suitable for tap-off unit 3L + PE (N not distributed, IT system also possible).
- (3) Maximum diameter by unipolar cable.
- (4) IP55 Rating.

#### KSB160DC

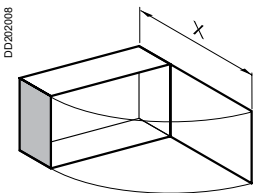

X = 625.5

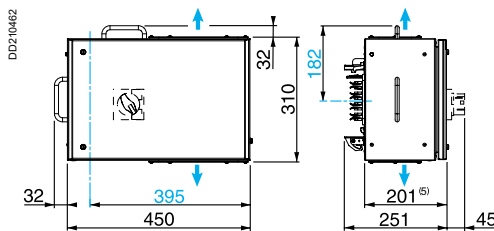

#### KSB250DC

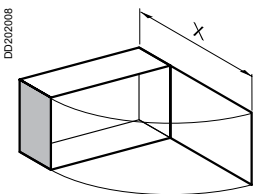

X = 726.5

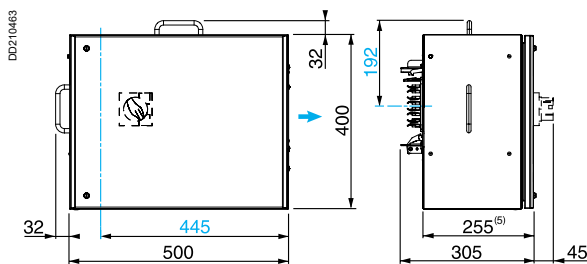

#### KSB400DC

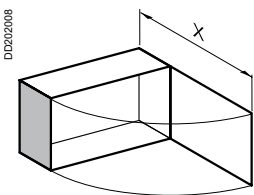

X = 976.5

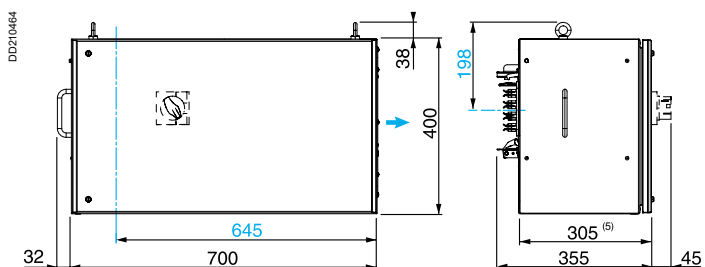

- Cable exit
- Centre line of tap-off outlets
- (5) Protruding

# Plug-in tap-off units

For Compact NSX circuit breakers equipped with metering devices

**Tap-off units for measurements and metering, not equipped**

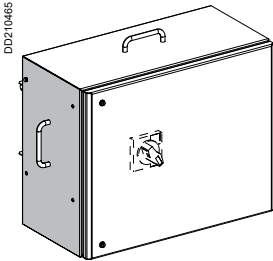

**KSB●●●DC●TRE**

The cover of the tap-off unit may be opened or closed only when the circuit breaker is in the Off position.

System earthing arrangement	Busbar trunking	TT-TNS-TNC-IT <sup>(1)</sup>	TNC
	Tap-off unit	TT-TNS-TNS-IT <sup>(1)</sup>	TNC
Tap-off outlets		3L + N + PE <sup>(2)</sup>	3L + PEN
Tap-off diagram (e.g. circuit breaker protection)			

Rating (A)	Type of circuit breaker (Not supplied)	Connection	Max. size (mm <sup>2</sup> )		Cable gland <sup>(3)</sup> (not supplied)	Cat. no.	Cat. no.	Weight (kg)
			Flexible	Rigid				
250 <sup>(4)</sup>	NSX250 Rotary handle LV429338T	Terminals	70	150	ISO 32 max.	<b>KSB250DC4TRE</b>	<b>KSB250DC5TRE</b>	13.50
400 <sup>(4)</sup>	NSX400 Rotary handle LV432598T	Terminals	150	240	ISO 40 max.	<b>KSB400DC4TRE</b>	<b>KSB400DC5TRE</b>	19.50

- (1) The neutral must be protected or not distributed (3L + PE) for the IT system.
- (2) Also suitable for tap-off unit 3L + PE (N not distributed, IT system also possible).
- (3) Maximum diameter by unipolar cable.
- (4) IP55 Rating.

**KSB250DC●TRE**

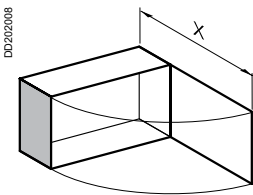

X = 726.5

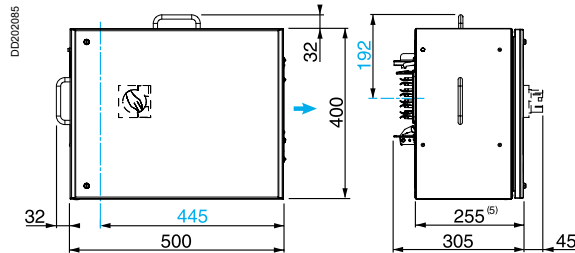

**KSB400DC●TRE**

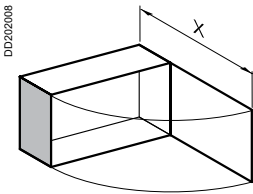

X = 976.5

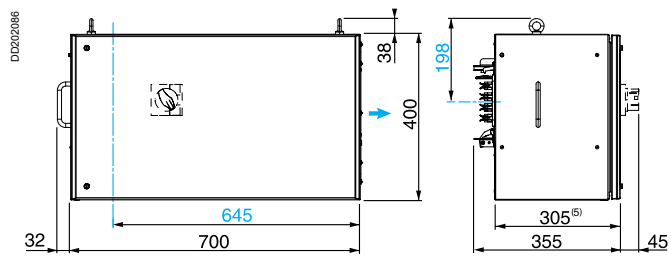

- Cable exit
- Centre line of tap-off outlets
- (5) Protruding



# Catalogue numbers and dimensions

## Plug-in tap-off units (for Canalis KT Only)

### For Compact NSX circuit breakers

#### Canalis KTA

#### DC - Tap-off units for Compact NSX, fixed, front-connected circuit breakers, not equipped

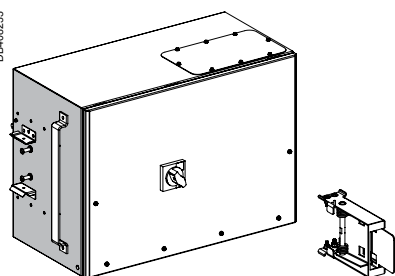

KTB0630DC●

Refer page 50, 51 for the installation of Tap off units on the KT ED outlet of different busway lengths.  
The cover of the tap-off unit may be opened or closed only when the circuit breaker is in the Off position.

System earthing arrangement	Busbar trunking	TT-TNS-TNC-IT <sup>(1)</sup> TNC
	Tap-off unit	TT-TNS-TNS-IT <sup>(1)</sup> TNC
Tap-off polarity		3L + N + PE <sup>(2)</sup> 3L + PEN
Tap-off diagram (e.g. circuit breaker protection)		

Rating (A)	Type of circuit breaker (Not Supplied)	Connection	Max. size (mm <sup>2</sup> ) L or N / PE	Cable gland <sup>(3)</sup> (not supplied)	Cat. no.	Cat. no.	Weight (kg)
630 <sup>(4)(6)(7)</sup>	NSX630 Rotary handle LV432598T	Terminals	2 x 300 / 1 x 150	ISO 70 max.	<b>KTB0630DC4</b>		45
		Terminals	2 x 300 / 1 x 150	ISO 70 max.		<b>KTB0630DC5</b>	46

- (1) The neutral must be protected or not distributed (3L + PE) for the IT system.
  - (2) Also suitable for tap-off unit 3L + PE (N not distributed, IT system also possible).
  - (3) Maximum diameter by unipolar cable.
  - (4) De-rating coefficient to apply: 0.9.
  - (5) The auto clamping system is included in the reference and delivered in the box.
  - (6) To be installed on KT ED type distribution length only.
  - (7) IP55 Rating.
- For an installation on Canalis KT delivered before 2016 contact our help desk for adaptation guidelines.

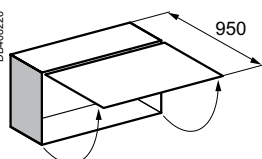

or

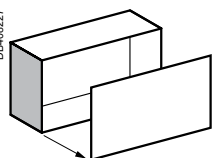

KTB0630DC●

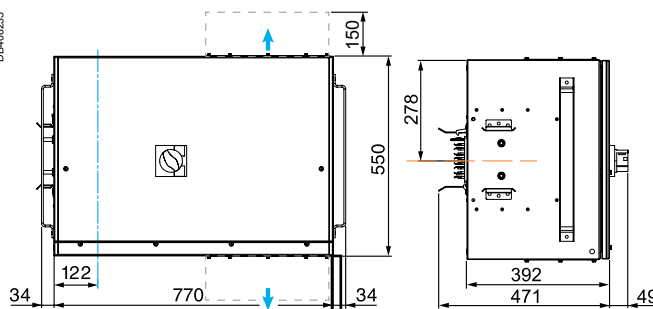

- Cable exit
- Center line of tap-off outlets
- Axis of Canalis KT
- Connection box to be fitted above or below

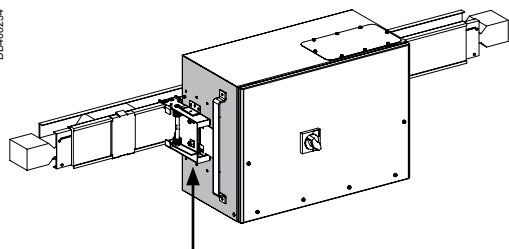

The auto clamping system has to be installed on the KT ED distribution units (5)

Option accessories	Cat. no.
Kit of connection bars	<b>KTB0630ZA01</b>
Connecting box	<b>KTB0630ZA04</b>

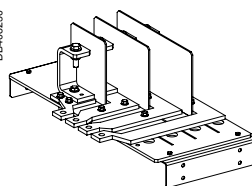

KTB0630ZA01

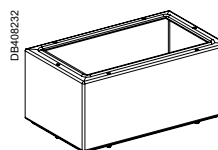

KTB0630ZA04

# Catalogue numbers and dimensions

## Plug-in tap-off units (for Canalis KT Only)

### For NF fuses

#### Tap-off units with isolator for cylindrical fuses

Disconnection by opening the tap-off unit cover

Tap-off unit disconnection by opening or closing the cover should be carried out only if the downstream load is de-energised.

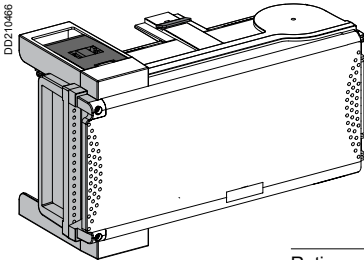

KSB●●●SF●

System earthing arrangement	Busbar trunking		TT-TNS-TNC-IT <sup>(1)</sup> TNC	
	Tap-off unit		TT-TNS-TNS-IT <sup>(1)</sup> TNC	
Tap-off polarity			3L + N + PE <sup>(2)</sup>	3L + PEN
Tap-off diagram (e.g. fuse protection)				

Rating (A)	For fuses (not supplied)	Connection	Max. size (mm <sup>2</sup> )		Cable gland <sup>(3)</sup> (not supplied)	Cat. no.	Cat. no.	Weight (kg)
			Flexible	Rigid				
50 <sup>(4)</sup>	NF 14 x 51 Type gG: 50 A max. Type aM: 50 A max.	Terminals	25	25	ISO 50 max.	<b>KSB50SF4</b>	<b>KSB50SF5</b>	2.40
100 <sup>(4)</sup>	NF 22 x 58 Type gG: 100 A max. Type aM: 100 A max.	Terminals	50	50	ISO 63 max.	<b>KSB100SF4</b>	<b>KSB100SF5</b>	5.00

- (1) The neutral must be not distributed (3L + PE) for the IT system.
- (2) Also suitable for tap-off unit 3L + PE (N not distributed, IT system also possible only if N not distributed).
- (3) Maximum diameter for a multipolar cable.
- (4) IP55 Rating.

#### KSB50SF●, KSB100SF●

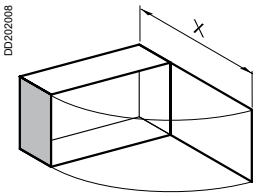

X = 432.5 (KSB50SF●)  
X = 545.5 (KSB100SF●)

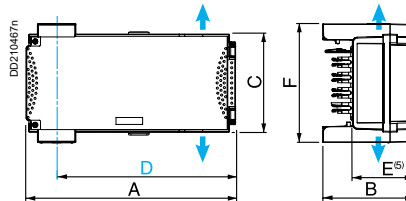

- Cable exit
- Centre line of tap-off outlets
- (5) Protruding

Dimensions	Rating (A)	
	50	100
A	356	444
B	153	178
C	167	202
D	309	397
E	103	128
F	202	220

# Plug-in tap-off units For NF fuses

## Canalis KTA

### Tap-off units with isolator for blade-type fuses

Disconnection by opening the tap-off unit cover

Tap-off unit disconnection by opening or closing the cover should be carried out only if the downstream load is de-energised. It is possible to install an OF contact triggered by cover opening (see the "Accessories" section, page 122).

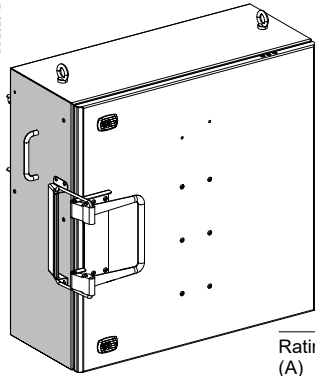

KSB400SE●

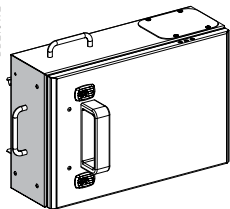

KSB160SE●  
KSB250SE●

System earthing arrangement	Busbar trunking	TT-TNS-TNC-IT <sup>(1)</sup>	TNC
	Tap-off unit	TT-TNS-TNS-IT <sup>(1)</sup>	TNC
Tap-off polarity	3L + N + PE <sup>(2)</sup>		3L + PEN
Tap-off diagram (e.g. fuse protection)			

Rating (A)	For blade-type fuses (not supplied)	Connection	Max. size (mm <sup>2</sup> )		Cable gland (not supplied)	Cat. no.	Cat. no.	Weight (kg)
			Flexible	Rigid				
100 <sup>(6)</sup>	Size 00 Type gG: 100 A max. Type aM: 100 A max.	Terminals	50	50	ISO 63 <sup>(3)</sup> max.	KSB100SE4 <sup>(6)</sup>	KSB100SE5 <sup>(6)</sup>	5.00
160 <sup>(6)</sup>	Size 00 Type gG: 160 A max. Type aM: 160 A max.	Terminals	35	50	ISO 20 <sup>(4)</sup> max.	KSB160SE4	KSB160SE5	11.00
	Size 0 Type gG: 160 A max. Type aM: 160 A max.	Terminals	35	50	ISO 20 <sup>(4)</sup> max.	KSB160SF4	KSB160SF5	11.00
250 <sup>(6)</sup>	Size 1 Type gG: 250 A max. Type aM: 250 A max.	Terminals	150	150	ISO 32 <sup>(4)</sup> max.	KSB250SE4	KSB250SE5	20.00
400 <sup>(6)</sup>	Size 2 Type gG: 400 A max. Type aM: 400 A max.	Terminals	240	240	ISO 40 <sup>(4)</sup> max.	KSB400SE4	KSB400SE5	29.20

- (1) The neutral must be not distributed (3L + PE) for the IT system.
- (2) Also suitable for tap-off unit 3L + PE (N not distributed, IT system also possible only if N not distributed).
- (3) Maximum diameter for a unipolar cable.
- (4) Cable gland for multipolar cable only.
- (5) For 100 A dimensions, see "Tap-off units with insulators for cylindrical fuses", page 115 cat. no. KSB100SF●.
- (6) IP55 Rating.

#### KSB160SE●, KSB250SE●

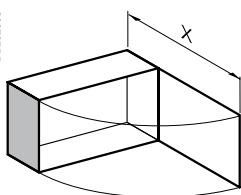

X = 577.5 (KSB160SE●)  
X = 777 (KSB250SE●)

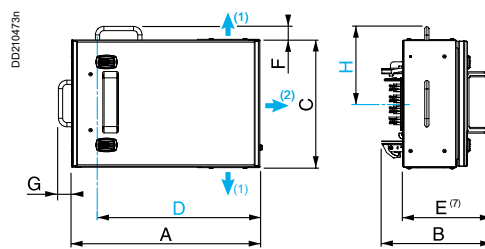

Dimensions	Rating (A)	
	160	250
A	450	600
B	257	308
C	300	400
D	395	548
E	207	258
F	32	32
G	32	32
H	182	192

#### KSB400SE●

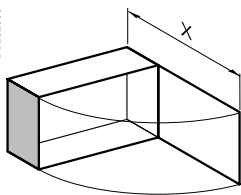

X = 855

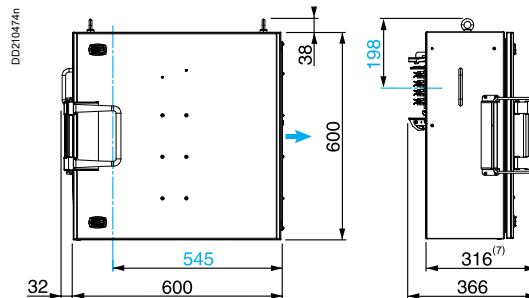

- ➡ Cable exit: (1) exit of KSB160S●●, (2) exit of KSB250SE●
- Centre line of tap-off outlets
- (7) Protruding



#### Tap-off unit with isolator for screw-type fuses

Disconnection by opening the tap-off unit cover

Tap-off unit disconnection by opening or closing the cover should be carried out only if the downstream load is de-energised.

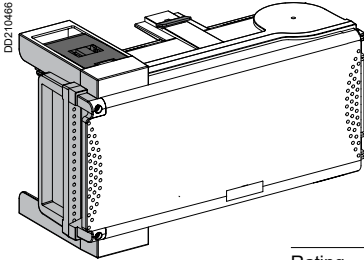

**KSB●●S●●**

System earthing arrangement	Busbar trunking	TT-TNS-TNC-IT <sup>(1)</sup>	TNC
	Tap-off unit	TT-TNS-TNS-IT <sup>(1)</sup>	TNC
Tap-off polarity		3L + N + PE <sup>(2)</sup>	3L + PEN
Tap-off diagram (e.g. fuse protection)			

Rating (A)	For fuses (not supplied)	Connection	Max. size (mm <sup>2</sup> )		Cable gland <sup>(3)</sup> (not supplied)	Cat. no.	Cat. no.	Weight (kg)
			Flexible	Rigid				
25 <sup>(4)</sup>	Diazed E27	Terminals	25	25	ISO 50 max	<b>KSB25SD4</b>	<b>KSB25SD5</b>	2.40
50 <sup>(4)</sup>	Néozed E18	Terminals	25	25	ISO 50 max.	<b>KSB50SN4</b>	<b>KSB50SN5</b>	2.40
63 <sup>(4)</sup>	Diazed E33	Terminals	25	25	ISO 63 max.	<b>KSB63SD4</b>	<b>KSB63SD5</b>	2.40

- (1) The neutral must be not distributed (3L + PE) for the IT system.
- (2) Also suitable for tap-off unit 3L + PE (N not distributed, IT system also possible only if N not distributed).
- (3) Maximum diameter for a multipolar cable.
- (4) IP55 Rating.

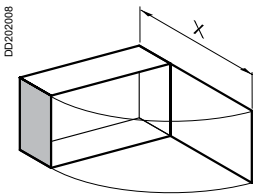

X = 432.5 (KSB25SD●, KSB50SN●)  
X = 545.5 (KSB63SD●)

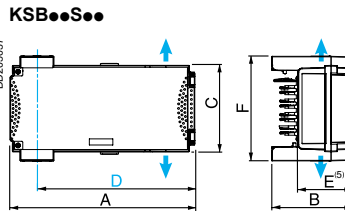

- ➡ Cable exit
- Centre line of tap-off outlets
- (5) Protruding

Dimensions	Rating (A)	
	25 and 50	63
A	356	444
B	153	178
C	167	202
D	309	397
E	103	198
F	202	220

# Plug-in tap-off units For DIN fuses

## Canalis KTA

### Tap-off units with isolator for blade-type fuses

Disconnection by opening the tap-off unit cover

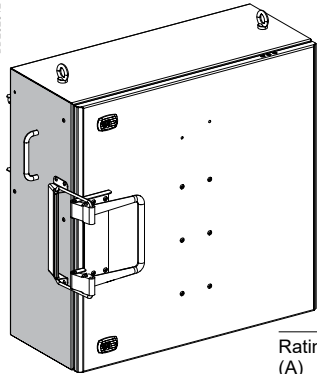

KSB400SE●

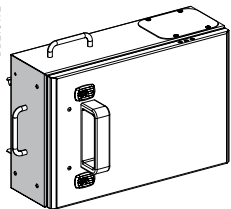

KSB160SE●  
KSB250SE●

Tap-off unit disconnection by opening or closing the cover should be carried out only if the downstream load is de-energised. It is possible to install an OF contact triggered by cover opening (see the "Accessories" section, page 122).

System earthing arrangement	Busbar trunking		TT-TNS-TNC-IT <sup>(1)</sup>		TNC		Weight (kg)
	Tap-off unit		TT-TNS-TNS-IT <sup>(1)</sup>		TNC		
Tap-off polarity	3L + N + PE <sup>(2)</sup>			3L + PEN			
Tap-off diagram (e.g. fuse protection)							
Rating (A)	For blade-type fuses (not supplied)	Connection	Max. size (mm <sup>2</sup> ) Flexible Rigid	Cable gland (not supplied)	Cat. no.	Cat. no.	
100 <sup>(6)</sup>	Size 00 Type gG: 100 A max. Type aM: 100 A max.	Terminals	50 50	ISO 63 <sup>(3)</sup> max.	KSB100SE4 <sup>(6)</sup>	KSB100SE5 <sup>(6)</sup>	5.00
160 <sup>(6)</sup>	Size 00 Type gG: 160 A max. Type aM: 160 A max.	Terminals	35 50	ISO 20 <sup>(4)</sup> max.	KSB160SE4	KSB160SE5	11.00
250 <sup>(6)</sup>	Size 1 Type gG: 250 A max. Type aM: 250 A max.	Terminals	150 150	ISO 32 <sup>(4)</sup> max.	KSB250SE4	KSB250SE5	20.00
400 <sup>(6)</sup>	Size 2 Type gG: 400 A max. Type aM: 400 A max.	Terminals	240 240	ISO 40 <sup>(4)</sup> max.	KSB400SE4	KSB400SE5	29.20

- (1) The neutral must be not distributed (3L + PE) for the IT system.
- (2) Also suitable for tap-off unit 3L + PE (N not distributed, IT system also possible only if N not distributed).
- (3) Maximum diameter for a unipolar cable.
- (4) Cable gland for multipolar cable only.
- (5) For 100 A dimensions, see "Tap-off units with insulators for cylindrical fuses", page 115 cat. no. KSB100SF●.
- (6) IP55 Rating.

#### KSB160SE●, KSB250SE●

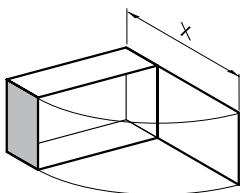

X = 577.5 (KSB160SE●)  
X = 777 (KSB250SE●)

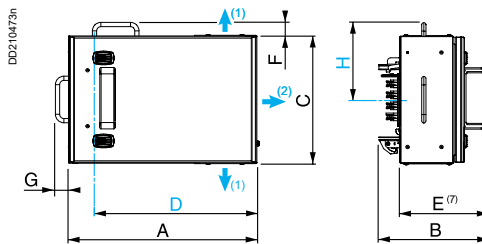

Dimensions	Rating (A)	
	160	250
A	450	600
B	257	308
C	300	400
D	395	548
E	207	258
F	32	32
G	32	32
H	182	192

#### KSB400SE●

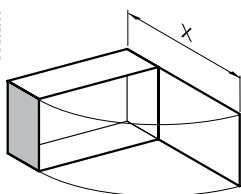

X = 855

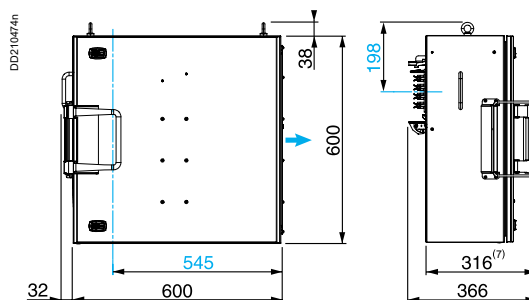

- ➡ Cable exit: (1) exit of KSB160S●●, (2) exit of KSB250SE●
- Centre line of tap-off outlets
- (7) Protruding

# Catalogue numbers and dimensions

## Plug-in tap-off units

### With switch-disconnector for DIN fuses



#### SD - Tap-off units with switch-disconnector

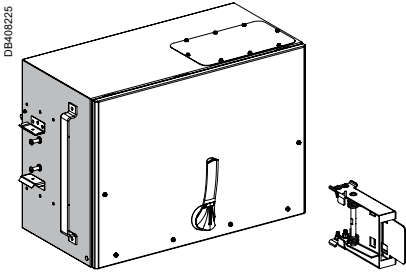

**KTB0630SD●**

Refer page 50, 51 for the installation of Tap off units on the KT ED outlet of different busway lengths.  
The cover of the tap-off unit may be opened or closed only when the switch-disconnector is in the Off position.

System earthing arrangement	Busbar trunking Tap-off unit	TT-TNS-TNC-IT <sup>(1)</sup> TNC					
		TT-TNS-TNS-IT <sup>(1)</sup> TNC	3L + N + PE <sup>(2)</sup>				
Tap-off polarity		3L + N + PE <sup>(2)</sup>	3L + PEN				
Tap-off diagram (e.g. fuse protection)							
Rating (A)	Type of fuses	Connection	Max. size (mm <sup>2</sup> ) L or N / PE	Cable gland <sup>(3)</sup> (not supplied)	Cat. no.	Cat. no.	Weight (kg)
630 <sup>(4)(6)(7)</sup>	DIN size 3	Terminals	2 x 300 / 1 x 150	ISO 70 max.	<b>KTB0630SD4</b>		64
		Terminals	2 x 300 / 1 x 150	ISO 70 max.		<b>KTB0630SD5</b>	68

- (1) The neutral must be protected or not distributed (3L + PE) for the IT system.
  - (2) Also suitable for tap-off unit 3L + PE (N not distributed, IT system also possible).
  - (3) Maximum diameter by unipolar cable.
  - (4) De-rating coefficient to apply: 0.87.
  - (5) The auto clamping system is included in the reference and delivered in the box.
  - (6) To be installed on KT ED type distribution length only.
  - (7) IP55 Rating.
- For an installation on Canalis KT delivered before 2016 contact our help desk for adaptation guidelines.

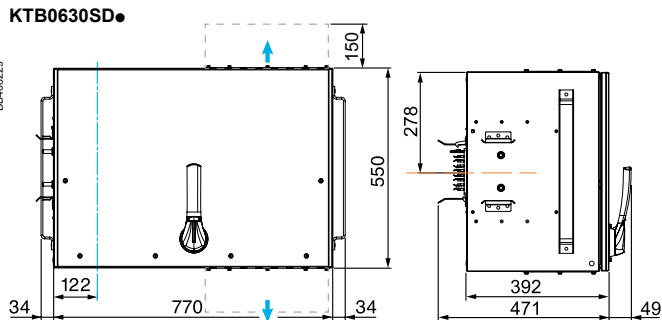
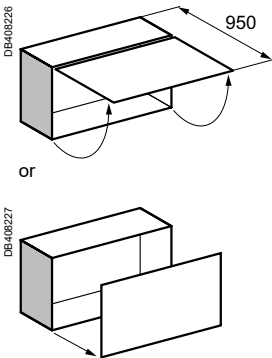

- Cable exit
- Center line of tap-off outlets
- Axis of Canalis KT
- Connection box to be fitted above or below

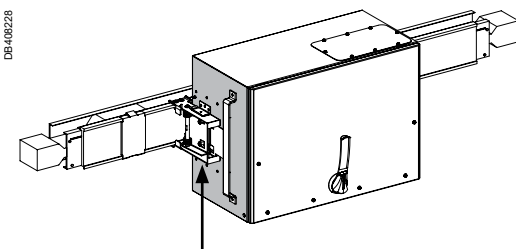

The auto clamping system has to be installed on the KT ED distribution units (5)

Option accessories	Cat. no.
Kit of connection bars	<b>KTB0630ZA02</b>
Extension rotary handle	<b>KTB0630ZA03</b>
Connecting box	<b>KTB0630ZA04</b>

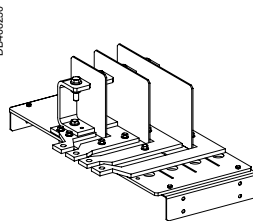

**KTB0630ZA02**

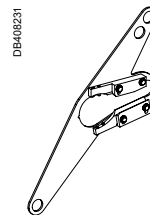

**KTB0630ZA03**

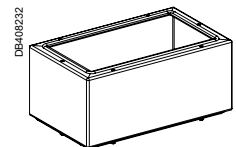

**KTB0630ZA04**

# Plug-in tap-off units

## With switch-disconnector for DIN fuses

### Canalis KTA

#### SE - Tap-off units with switch-disconnector internal arc tested IEC 61-641

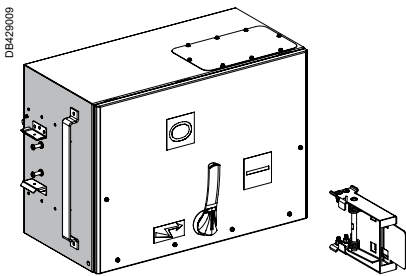

Refer page 50, 51 for the installation of Tap off units on the KT ED outlet of different busway lengths.  
The cover of the tap-off unit may be opened or closed only when the switch-disconnector is in the Off position.  
To be installed on KT ED type distribution length only.

System earthing arrangement	Busbar trunking	TT-TNS-TNC-IT <sup>(1)</sup> TNC
	Tap-off unit	TT-TNS-TNS-IT <sup>(1)</sup> TNC
Tap-off polarity		3L + N + PE <sup>(2)</sup> 3L + PEN
Tap-off diagram (e.g. fuse protection)		

KTB0630SE●

Rating (A)	Type of fuses	Connection	Max. size (mm <sup>2</sup> ) L or N / PE (kg)	Cable gland <sup>(3)</sup> (not supplied)	Cable exit side	Cat. no.	Cat. no.	Weight (kg)
630 <sup>(4)(6)</sup>	DIN size 3	Terminals	2 x 300 / 1 x 150	ISO 70 max.	Right	<b>KTB0630SE4R</b>		72
					Left	<b>KTB0630SE4L</b>		72
					Right		<b>KTB0630SE5R</b>	78
					Left		<b>KTB0630SE5L</b>	78

- (1) The neutral must be protected or not distributed (3L + PE) for the IT system.
  - (2) Also suitable for tap-off unit 3L + PE (N not distributed, IT system also possible).
  - (3) Maximum diameter by unipolar cable.
  - (4) De-rating coefficient to apply: 0.87.
  - (5) The auto clamping system and the kit of connection bars are included in the reference and delivered in the box.
  - (6) IP55 Rating.
- For an installation on Canalis KT delivered before 2016 contact our help desk for adaptation guidelines.

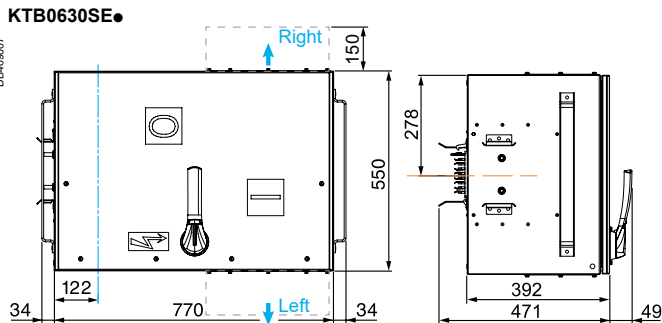
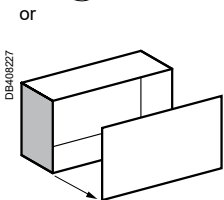
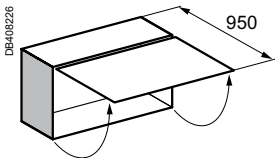

- ➡ Cable exit
- Center line of tap-off outlets
- Axis of Canalis KT
- - - Connection box to be fitted above or below

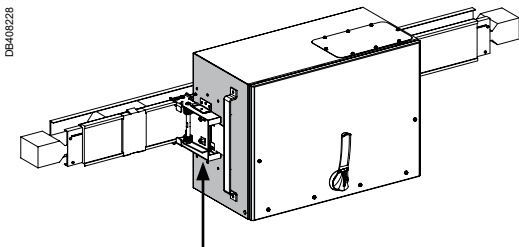

The auto clamping system has to be installed on the KT ED distribution units (5)

Option accessories	Cat. no.
Extension rotary handle	<b>KTB0630ZA03</b>
Connecting box	<b>KTB0630ZA04</b>
Plate with 5 cable glands 24 to 40 mm	<b>KTB0000GP01</b>
Plate with 1 cable clamp 30 to 70 mm	<b>KTB0000GP02</b>
Plate with 2 cable clamps 30 to 70 mm	<b>KTB0000GP03</b>

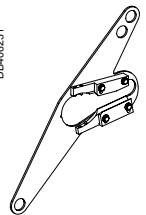

KTB0630ZA03

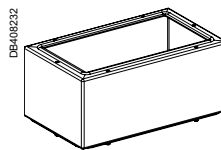

KTB0630ZA04

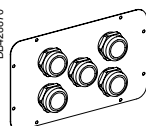

KTB0000GP01

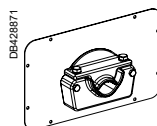

KTB0000GP02

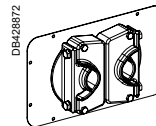

KTB0000GP03

# Catalogue numbers and dimensions

## Plug-in tap-off units

### For BS fuses

A

B

C

D

E

F

G

### Tap-off units for screw-mounted fuses

Disconnection by unplugging the tap-off unit

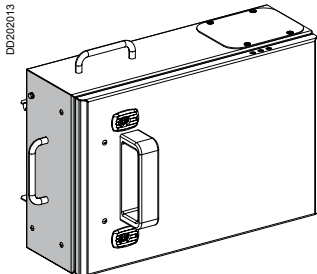

**KSB160SG4**

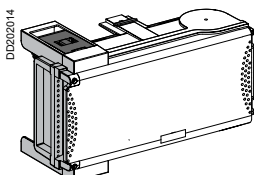

**KSB32SG4, KSB80SG4**

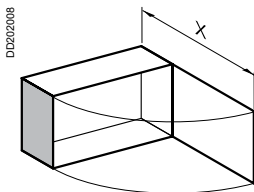

X = 432.5 (KSB32SG4)  
X = 545.5 (KSB80SG4)

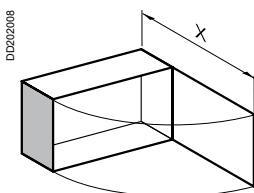

X = 577.5

Tap-off units to be installed on 2 meters elements, only on central outlet. Tap-off unit disconnection by opening or closing the cover should be carried out only if the downstreamload is de-energised.

System earthing arrangement	Busbar trunking	TT-TNS-TNC-IT <sup>(1)</sup>
	Tap-off unit	TT-TNS-TNS-IT <sup>(1)</sup>
Tap-off polarity	3L + N + PE <sup>(2)</sup>	
Tap-off diagram (e.g. fuse protection)		

Rating (A)	For fuses (not supplied)	Connection	Max. size (mm <sup>2</sup> )		Cable gland (not supplied)	Cat. no.	Weight (kg)
			Flexible	Rigid			
32 <sup>(5)</sup>	BS88 A1	Terminals	25	25	ISO 50 <sup>(3)</sup> max	<b>KSB32SG4</b>	2.40
80 <sup>(5)</sup>	BS88 A1 or A3	Terminals	35	50	ISO 63 <sup>(3)</sup> max or ISO 20 <sup>(4)</sup> max	<b>KSB80SG4</b>	5.00
160 <sup>(5)</sup>	BS88 B1 or B2	Terminals	35	50	ISO 20 <sup>(4)</sup> max	<b>KSB160SG4</b>	11.00

- (1) The neutral must be not distributed (3L + PE) for the IT system.
- (2) Also suitable for tap-off unit 3L + PE (N not distributed).
- (3) Maximum diameter for a multipolar cable.
- (4) Maximum diameter for a unipolar cable.
- (5) IP55 Rating.

#### KSB32SG4, KSB80SG4

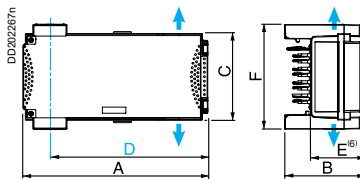

Dimensions	Rating (A)	
	32	80
A	356	444
B	153	178
C	167	202
D	309	397
E	103	128
F	202	220

#### KSB160SG4

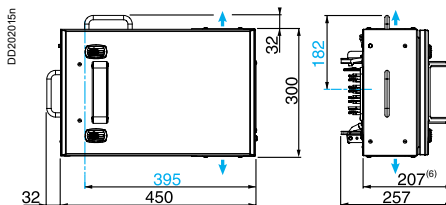

- Cable exit
- Centre line of tap-off outlets
- (6) Protruding

# Accessories for tap-off units from Canalis KS range IP55

## Canalis KTA

### Accessories for all tap-off units for modular devices

Designation	Description	Cat. no.	Weight (kg)
<b>Modular blanking plate</b>	Divisible set of 10 x 5	<b>13940</b>	0.08
<b>Adhesive label<sup>(1)</sup></b>	Set of 12 label-holders (H = 24 mm, W = 180 mm)	<b>LVS08905</b>	-
	Set of 12 labels (H = 24 mm, W = 432 mm)	<b>LVS08903</b>	-
	Set of 12 divisible labels (H = 24 mm, W = 650 mm)	<b>LVS08907</b>	-

(1) Self-adhesive support complete with transparent cover and paper label.

### Accessories for all sheet-metal tap-off units

Designation	For tap-off unit	Order in multiples of	Cat. no.	Weight (kg)
<b>Cover contact (break before opening)</b>	KSB100S● to KSB400S●	1	<b>KSB400ZC1</b>	0.03

A

B

C

D

E

F

G

# Catalogue numbers and dimensions

## Bolted tap-off units

### For Compact NSX/NS circuit breakers

#### CB - Bolted tap-off units for Compact NSX/NS with front connections<sup>(1)</sup>

Rating (A)	Type of circuit breaker <sup>(2)</sup>	Max. connection capacity (mm <sup>2</sup> )		Cat. no.	Weight (kg)		
		Phases and neutral	PE		3L + PE	3L + N + PE 3L + N + PER	3L + PEN
400 <sup>(5)</sup> to 630 <sup>(5)</sup>	NSX400 or NSX630 <sup>(3)</sup> Rotary handle LV432598	3 x 300	150	<b>KTB0630CB3</b>	<b>KTB0630CB4</b>	<b>KTB0630CB5</b>	35.00
800 <sup>(5)</sup> to 1000 <sup>(5)</sup>	NS800 or NS1000 <sup>(4)</sup> Rotary handle 33878	4 x 300	200	<b>KTB1000CB3</b>	<b>KTB1000CB4</b>	<b>KTB1000CB5</b>	45.00
1250 <sup>(6)</sup>	NS1250 Rotary handle 33878	4 x 300	240	<b>KTB1250CB3</b>	<b>KTB1250CB4</b>	<b>KTB1250CB5</b>	50.00

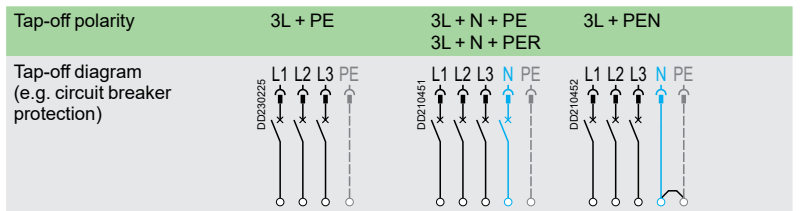

- (1) Installation KTA●●●●EB●●● bolted section only.
- (2) Circuit breaker and rotary handle not supplied.
- (3) De-rating coefficient to apply on NSX630A: 0.94.
- (4) It is recommended a derating factor of 0.93 be applied when using a Compact NS1000 type L circuit breaker.
- (5) IP54 only.
- (6) IP31 only.

#### KTB●●●●CB● from 400 to 1000 A

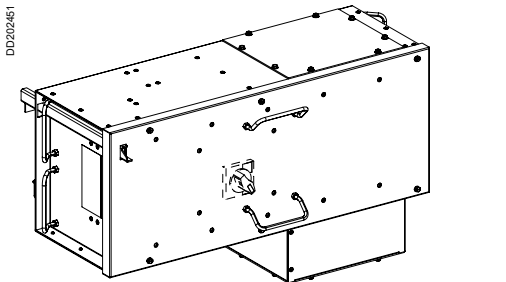

KTB0630CB●

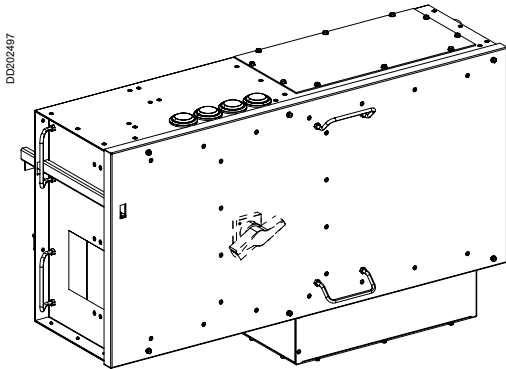

KTB1000CB●

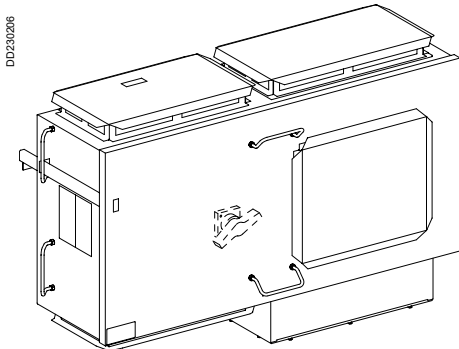

KTB1250CB●

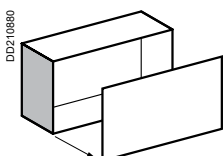

DD210880

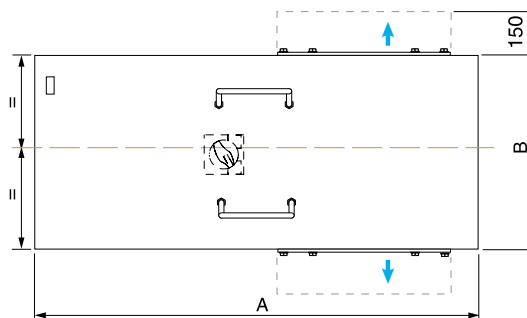
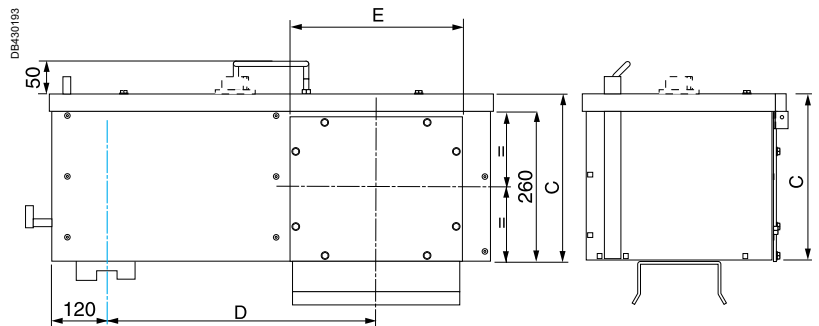

#### Table of dimensions

Dim.	Rating (A)	
	400 to 630	800 to 1000
A	860	1130
B	350	550
C	300	330
D	547	710
E	315	510

#### From 1250 A

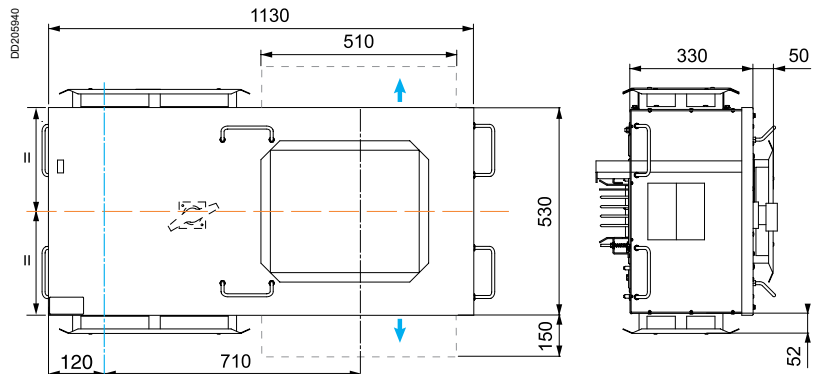

- ➔ Cable exit
- Center line of tap-off outlets
- Axis of Canalis KT
- - - Connection box to be fitted above or below

# Bolted tap-off units

## With switch-disconnectors for DIN fuses

### Canalis KTA

#### HF - Bolted tap-off units with switch-disconnectors<sup>(1)</sup>

A

B

C

D

E

F

G

Rating (A)	DIN fuse size (not supplied) <sup>(2)</sup>	Max. connection capacity (mm <sup>2</sup> )		Cat. no.			Weight (kg)
		Phases and neutral	PE				
630 <sup>(3)(5)</sup>	T3	3 x 300	150	<b>KTB0630HF3</b>	<b>KTB0630HF4</b>	<b>KTB0630HF5</b>	54.00
1000 <sup>(3)(4)(5)</sup>	T4	4 x 300	200	<b>KTB1000HF3</b>	<b>KTB1000HF4</b>	<b>KTB1000HF5</b>	96.00

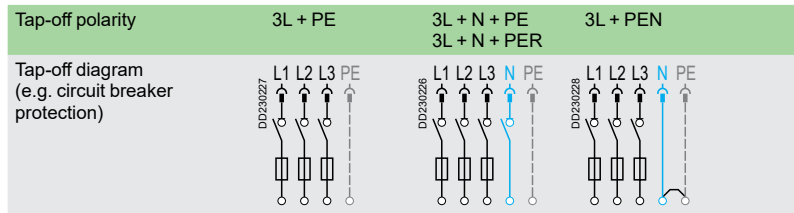

- (1) Installation KTA●●●●EB●●● bolted section only.
- (2) Switch-disconnectors and rotary handle **supplied**.
- (3) Derating coefficient to apply: 0.8.
- (4) KTB1000HF● cannot be installed on EB straight lengths.
- (5) IP31 only.

#### KTB●●●●HF●

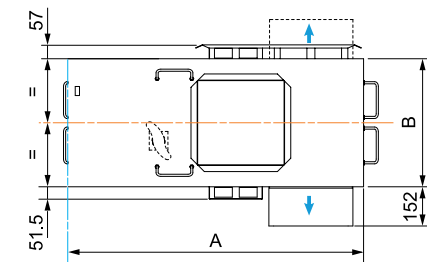
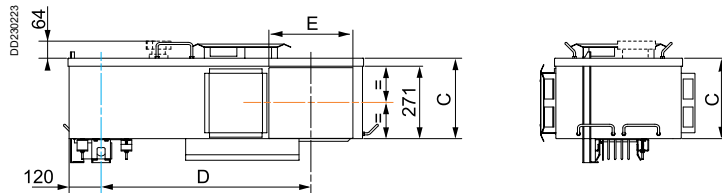

#### Table of dimensions

Dim.	Rating (A)	
	630	1000
A	1108	1438
B	480	690
C	300	330
D	786.5	1010
E	315	510

- Cable exit
- Center line of tap-off outlets
- Axis of Canalis KT
- Connection box to be fitted above or below

DD230200

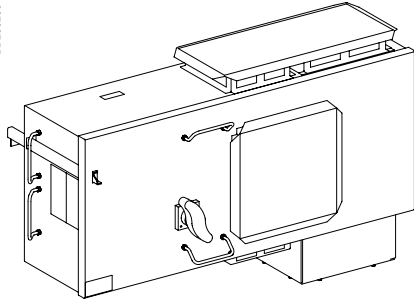

KTB0630HF●

DD230203

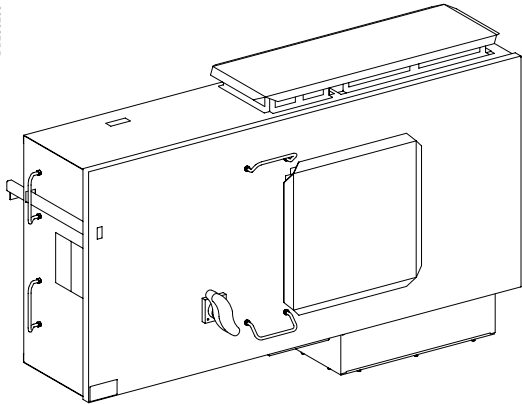

KTB1000HF●

DD210880

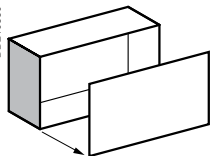

# Catalogue numbers and dimensions

## Coupling isolators from 1000 to 2500 A



### SL - Compact NS type NA coupling isolators

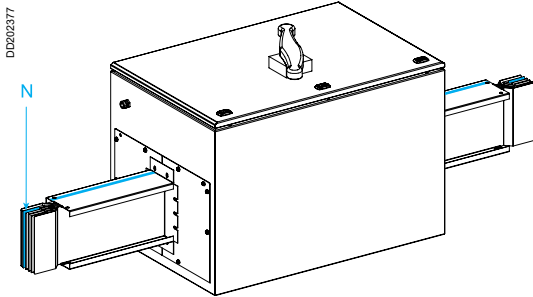

KTA●●●●SL●1

Fits equally on ducting in a flat position, on the edge (door accessible from above or below) or vertically.  
Tap-off unit door locking is achieved using a door key lock.

Rating (A)	Type of isolator (supplied)	Cat. no.			Weight (kg)
		3L + PE	3L + N + PE	3L + N + PER <sup>(1)</sup>	
1000 <sup>(2)</sup>	NS1000 NA	KTA1000SL31	KTA1000SL41	KTA1000SL51	135.00
1250 <sup>(2)</sup>	NS1250 NA	KTA1250SL31	KTA1250SL41	KTA1250SL51	140.00
1600 <sup>(2)</sup>	NS1600 NA	KTA1600SL31	KTA1600SL41	KTA1600SL51	150.00

(1) To order the 3L + N + PER version with reinforced Isc, replace KTA●●●●SL51 by KTA●●●●SL71.  
(2) IP55 Rating.

KTA●●●●SL●1

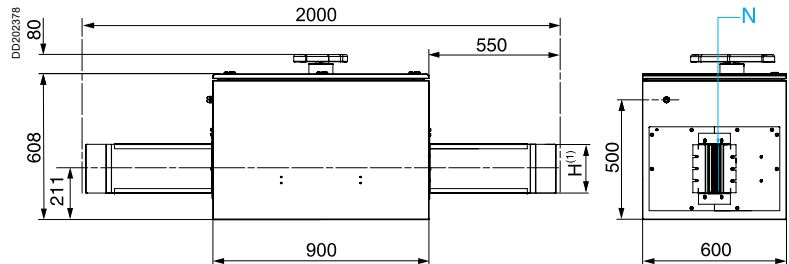
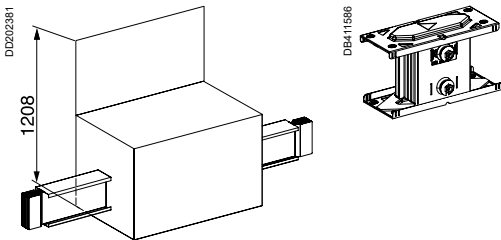

(1) See the "Trunking cross-section" table below.

### SL - Interpact INV coupling isolators

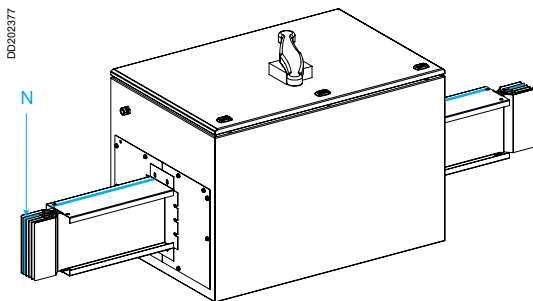

KTA●●●●SL●1

Fits equally on ducting in a flat position, on the edge or vertically.  
Tap-off unit door locking is achieved using a door key lock.

Rating (A)	Type of isolator (supplied)	Cat. no.			Weight (kg)
		3L + PE	3L + N + PE	3L + N + PER	
2000 <sup>(1)</sup>	INV2000	KTA2000SL31	KTA2000SL41	KTA2000SL51	170.00
2500 <sup>(1)</sup>	INV2500	KTA2500SL31	KTA2500SL41	KTA2500SL51	180.00

(1) IP55 Rating.

KTA●●●●SL●1

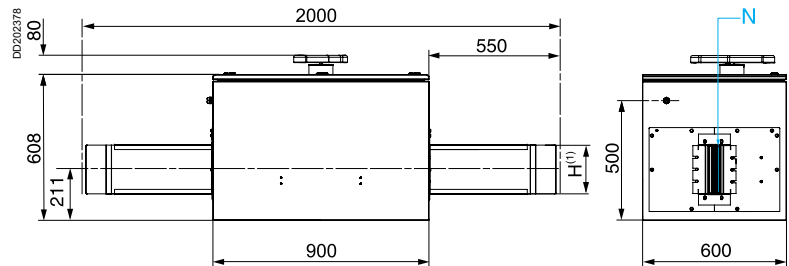
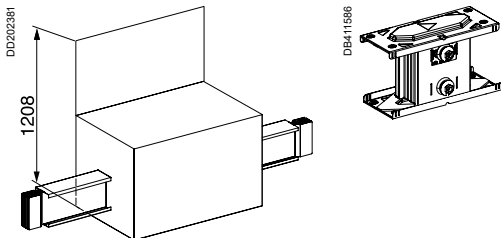

(1) See the "Trunking cross-section" table below.

### Trunking cross-section

Rating (A)	800 <sup>(1)</sup>	1000	1250	1600	2000	2500	3200	4000	5000
Height H (mm)	74	104	124	164	204	244	324	404	244
Width W (mm)	140	140	140	140	140	140	140	140	140

(1) Important: for the 800 A rating, indicate "KTA0800".

# 2500 A internal arcing resistant coupling isolator

## Canalis KTA

### RL - Coupling isolator with Interpact INV

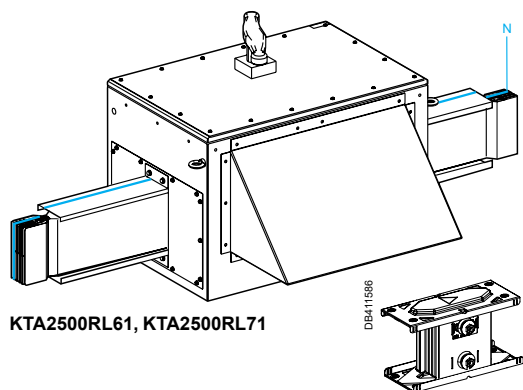

To be installed edgewise on busbar trunking, door accessible from above or below. The enclosure door is fitted with a key lock.

Rating (A)	Type of switch (supplied)	Cat. no.		Weight (kg)
		3L + N + PE	3L + N + PER	
2500 <sup>(1)</sup>	INV 2500 right	KTA2500RL61	KTA2500RL71	300.00
2500 <sup>(1)</sup>	INV 2500 left	KTA2500RL62	KTA2500RL72	300.00

(1) IP55 Rating.

This unit has a short circuit withstand  $I_{cw} = 110 \text{ kA } 0.1 \text{ s}$  and an internal arcing withstand for  $110 \text{ kA } 0.3 \text{ s}$ .

The coupling device can support only one closure at 80 kA.

Switch disconnector inside: Interpact INV ref: 31368 for 3L + PEN, ref: 31369 for 3L + N + PER

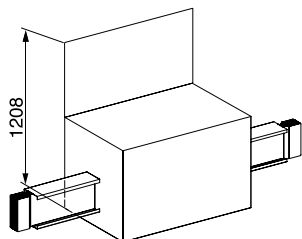
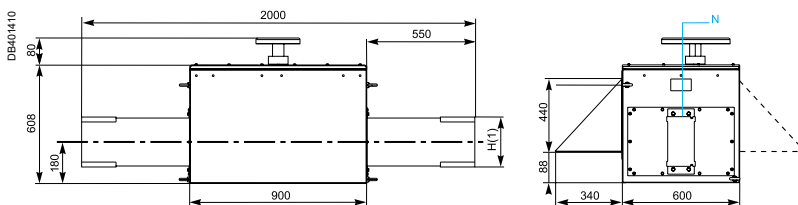
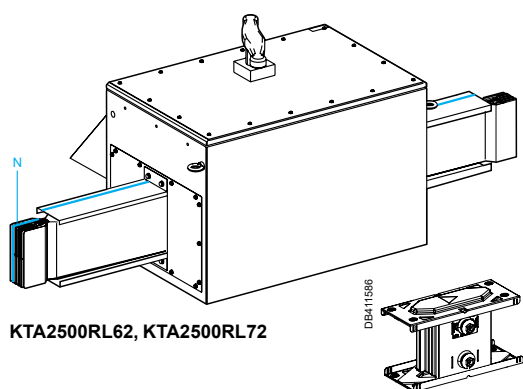

### SL - Masterpact NW coupling isolators

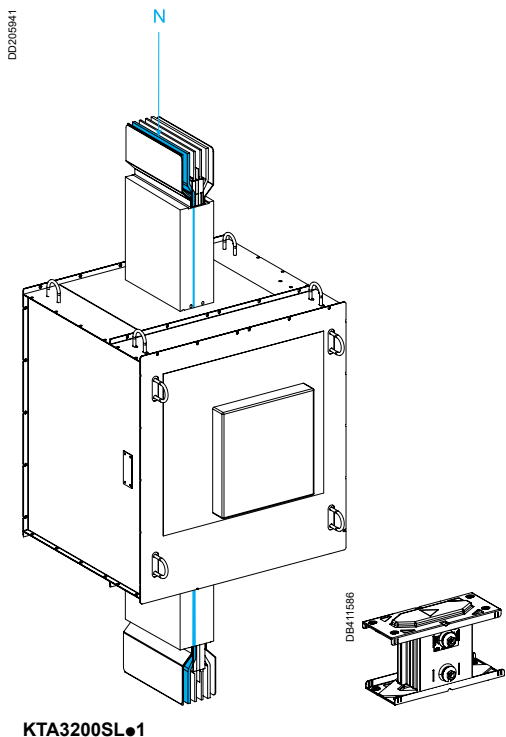

Notice: If the coupling isolator is installed on a **horizontal** busbar trunking the device must be only used as a disconnector and without any accessories (MX, XF, Motor MCH...).

Rating (A)	Type of isolator (supplied)	Cat. no.			Weight (kg)
		3L + PE	3L + N + PE	3L + N + PER <sup>(1)</sup>	
3000 <sup>(2)(3)</sup>	NW3200 HA	<b>KTA3200SL31</b>	<b>KTA3200SL41</b>	<b>KTA3200SL51</b>	320.00

(1) To order the 3L + N + PER version with reinforced Isc, replace KTA●●●SL51 by KTA●●●SL71.

(2) The use of this coupling isolator requires derating the busway run to 3000 A.

(3) IP55 Rating.

#### KTA3200SL•1

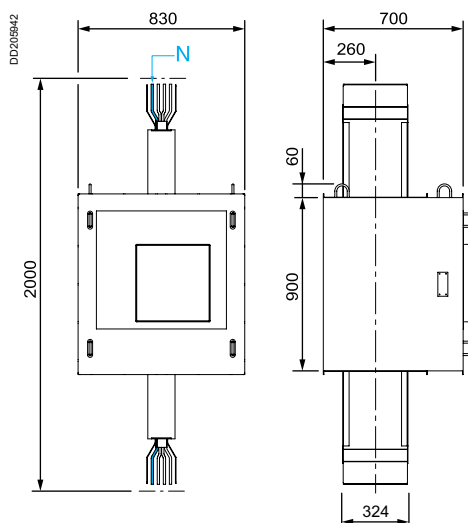

# Protection of the run using Compact NS circuit breakers from 1000 to 1600 A

## Canalis KTA

### PL - Protection of the run using Compact NS circuit breakers

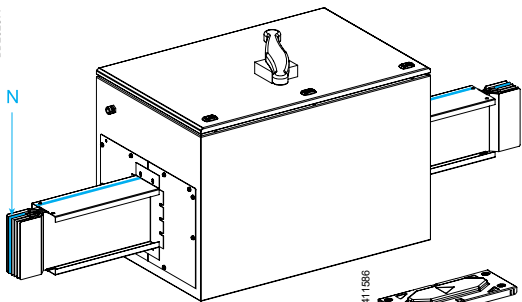

KTA●●●●PL●1

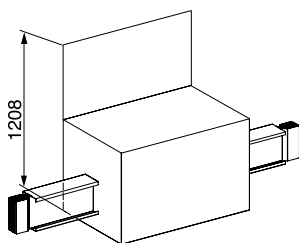

Fits equally on ducting in a flat position, on the edge or vertically. Tap-off unit door locking is achieved using a door key lock.

Rating (A)	Type of isolator <sup>(2)</sup> (supplied)	Cat. no.			Weight (kg)
		3L + PE	3L + N + PE	3L + N + PER <sup>(3)</sup>	
1000 <sup>(4)</sup>	NS1000 N	KTA1000PL31	KTA1000PL41	KTA1000PL51	135.00
1250 <sup>(4)</sup>	NS1250 N	KTA1250PL31	KTA1250PL41	KTA1250PL51	140.00
1600 <sup>(4)</sup>	NS1600 N	KTA1600PL31	KTA1600PL41	KTA1600PL51	150.00

KTA●●●●PL●1

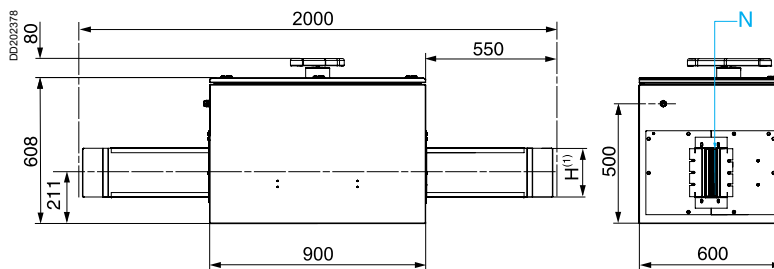

- (1) See the "Trunking cross-section" table below.
- (2) Manual fixed compact NS circuit breakers type N equipped with a Micrologic 2.0 control unit.
- (3) To order the 3L + N + PER version with reinforced Isc, replace KTA●●●●PL51 by KTA●●●●PL71.
- (4) IP55 Rating.

### Protection of a run > 1600 A

To install protection of a run > 1600 A, consult your sales office.

### Trunking cross-section

Rating (A)	800 <sup>(1)</sup>	1000	1250	1600	2000	2500	3200	4000	5000
Height H (mm)									
Width W (mm)									
	140	140	140	140	140	140	140	140	140
	74	104	124	164	204	244	324	404	244
									130
									244

(1) Important: for the 800 A rating, indicate "KTA0800".

For further information about the use and the dimensions, consult your sales office.



### Double skin aluminium enclosure

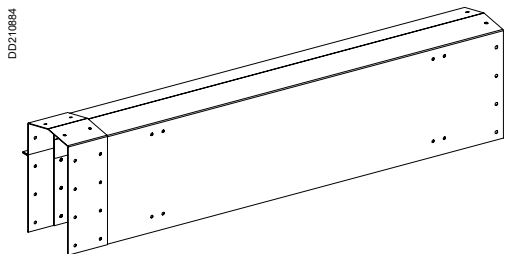

For outdoor applications.

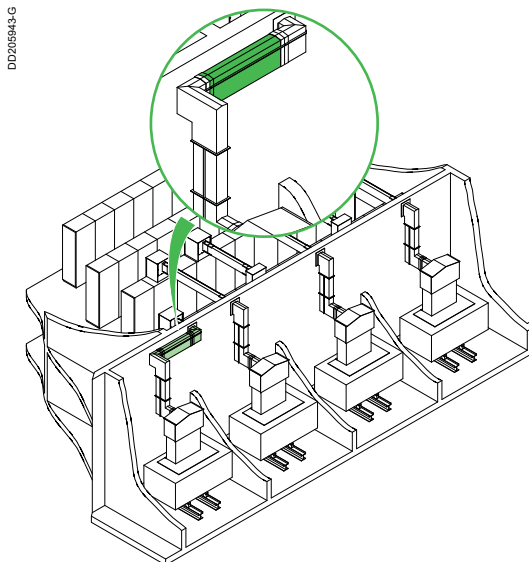

### Reduction sections

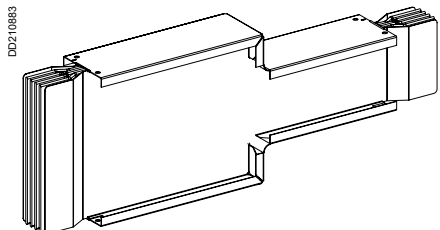

For reducing busbar trunking ratings.  
**NOTE:** must be used in conjunction with appropriate protection.  
 Joint pack is provided as per HB (B to be lowered as mentioned below image) of the reduction section.

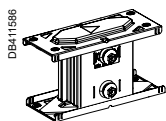

**NOTE:** Bigger rating Junction Block is supplied.

Table of sizes

H <sub>A</sub>	H <sub>B</sub>	74	104	124	164	204	244	324	404
74	74								
104	74								
124	74								
164	74								
204	74								
244	74								
324	74								
404	74								

Available.

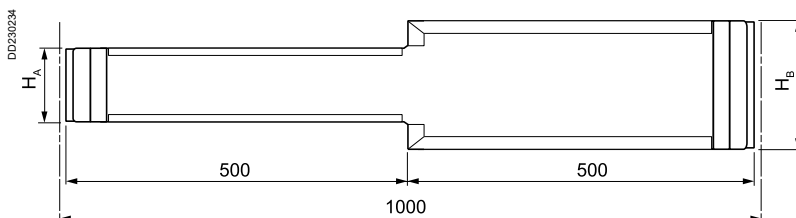

### Edgewise elbow with made to measure angles

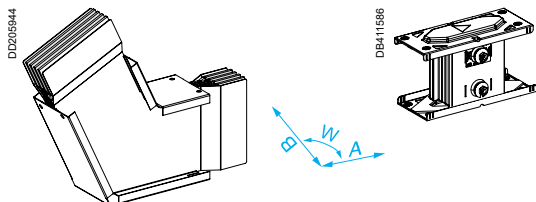

# Special products

## IP55

### Canalis KTA

#### 4-limbed unit

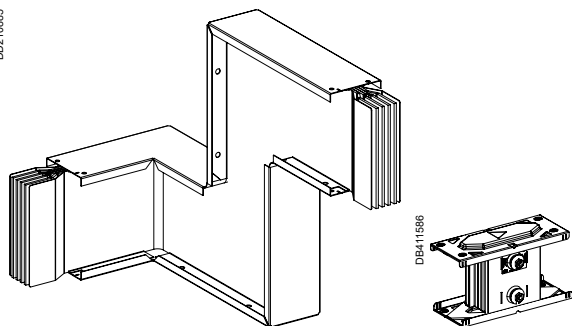

#### Edgewise/flat elbow feed unit

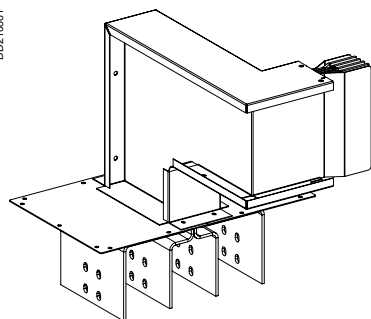

#### On demand

- Surface treatment on conductors for corrosive atmospheres.
- Special colours.
- Seaworthy packaging.
- etc.

# Catalogue numbers and dimensions

## Canalis KH substitution by Canalis KT

### KTA/KHF connection elements

#### Canalis KTA or KHF

#### HT - Connection elements

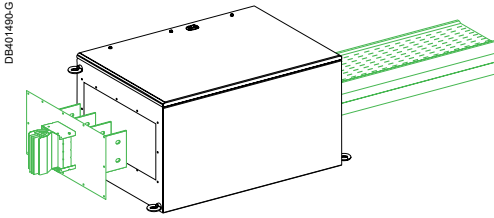

KTB0350HT01

Ratings (A)	Cat. no.			Weight (kg)
	3L + PE	3L + N + PE	3L + N + PER	
See the table below	KTB0350HT01	KTB0350HT01	KTB0350HT01	63.00
	KTB0350HT02	KTB0350HT02	KTB0350HT02	80.00
	-	-	KTB0350HT12	80.00
	KTB0510HT01	KTB0510HT01	KTB0510HT01	88.00
	KTB0510HT02	KTB0510HT02	KTB0510HT02	127.00
	KTB0510HT03	KTB0510HT03	KTB0510HT03	137.00
	-	-	KTB0510HT11	88.00

End feed units (J, K, M = 115) are not included in the reference and must be ordered separately

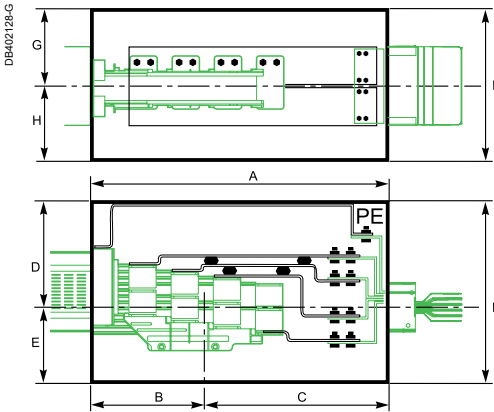

#### Table of dimensions

	A	B	C	D	E	F	G	H	I
KTB0350HT01	850	331.5	518.5	300	300	600	258	208	466
KTB0350HT02	850	331.5	518.5	300	300	600	258	208	466
KTB0350HT12	850	331.5	518.5	300	300	600	258	208	466
KTB0510HT01	890	310	580	300	300	600	329	306	635
KTB0510HT02	890	310	580	300	300	600	329	306	635
KTB0510HT03	890	310	580	300	300	600	329	306	635
KTB0510HT11	890	310	580	300	300	600	329	306	635

KHF type	Rating	L busway	KT type	Rating	H busway	H flange	Connection ref.
KHF14	1000	166	KTA1000	1000	104	230	KTB0350HT01
KHF16	1200	166	KTA1250	1250	124	230	
KHF18	1450	166	KTA1600	1600	164	350	
KHF26	2200	238	KTA2500	2500	244	350	KTB0350HT02
KHF28	2500	238	KTA2500	2500	244	350	
KHF27	2200	310	KTA2500	2500	244	350	
KHF29	2500	310	KTA2500	2500	244	350	KTB0350HT12
KHF36	3000	310	KTA3200	3200	324	510	
KHF38	3500	310	KTA4000	4000	404	510	
KHF39	3500	382	KTA4000	4000	404	510	KTB0510HT01
KHF46	4000	382	KTA4000	4000	404	510	
KHF48	4500	382	KTC5000 <sup>(1)</sup>	5000	404	510	
KHF56	5000	454	KTC5000 <sup>(1)</sup>	5000	404	510	KTB0510HT02
KHF58	5500	454					

(1) See the KTC catalogue for details of the product range.

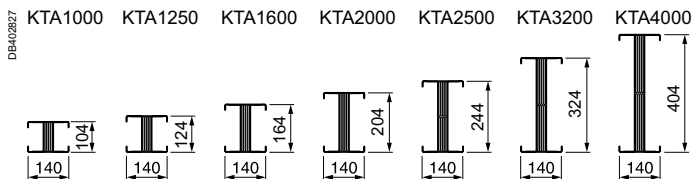

KHF Polarity	KTA Polarity
3L + PE	3L + PE
3L + 1/2N + PE	3L + N + PE
3L + N + PE	3L + N + PE
3L + N + PER <sup>(2)</sup>	3L + N + PER

(2) Version with 120 mm<sup>2</sup> Cu conductor or entire conductor.

# Canalis KH substitution by Canalis KT

## Preserved KH tap-off units and substitution table

### Canalis KTA

#### Plug-in tap-off units

Protection type	Polarity	Rating	Catalogue number	Status	Substituted by	
Isolator and fuse carriers	3L + PE	160	KH016SD13	Removed	KHB0250SE5	
		250	KH025SD13	Removed	KHB0250SE5	
		400	KH040SD13	Removed	KHB0630SE5R or KHB0630SE5L	
		630	KH063SD13	Removed	KHB0630SE5R or KHB0630SE5L	
	3L + N + PE	160	KH016SD14	Removed	KHB0250SE4	
		250	KH025SD14	Removed	KHB0250SE4	
		400	KH040SD14	Removed	KHB0630SE4R or KHB0630SE4L	
		630	KH063SD14	Removed	KHB0630SE4R or KHB0630SE4L	
	3L + PEN	160	KH016SD15	Removed	KHB0250SE5	
		250	KH025SD15	Removed	KHB0250SE5	
		400	KH040SD15	Removed	KHB0630SE5R or KHB0630SE5L	
		630	KH063SD15	Removed	KHB0630SE5R or KHB0630SE5L	
	3L + NP + PE	160	KH063SD1530758	Removed	KHB0630SE5R or KHB0630SE5L	
		250	KH016SD24	Removed	No	
		400	KH025SD24	Removed	No	
		630	KH040SD24	Removed	No	
	Switch and fuse carriers	3L + PE	200	KH020SD33	Removed	KHB0250SE5
			315	KH031SD33	Removed	KHB0630SE5R or KHB0630SE5L
			500	KH050SD33	Removed	KHB0630SE5R or KHB0630SE5L
			630	KH063SD33	Removed	KHB0630SE5R or KHB0630SE5L
3L + N + PE		50	KH005SD34	Removed	KHB0250SE4	
		100	KH010SD34	Removed	KHB0250SE4	
		200	KH020SD34	Removed	KHB0250SE4	
		250	KH025SE341	Removed	KHB0250SE4	
		315	KH031SD34	Removed	KHB0630SE4R or KHB0630SE4L	
		400	KH040SE341	Removed	KHB0630SE4R or KHB0630SE4L	
		500	KH050SD34	Removed	KHB0630SE4R or KHB0630SE4L	
		630	KH063SE341	Removed	KHB0630SE4R or KHB0630SE4L	
3L + PEN		50	KH005SD35	Removed	KHB0250SE5	
		100	KH010SD35	Removed	KHB0250SE5	
		200	KH020SD35	Removed	KHB0250SE5	
		250	KH025SE351	Removed	KHB0250SE5	
		315	KH031SD35	Removed	KHB0630SE5R or KHB0630SE5L	
		400	KH040SE351	Removed	KHB0630SE5R or KHB0630SE5L	
		500	KH050SD35	Removed	KHB0630SE5R or KHB0630SE5L	
		630	KH063SE351	Removed	KHB0630SE5R or KHB0630SE5L	
3L + NP + PE	200	KH020SD44	Removed	No		
	315	KH031SD44	Removed	No		
	500	KH050SD44	Removed	No		
	630	KH063SD44	Removed	No		
Circuit breaker manual	3L + N + PE	160	KH016SD541	Removed	KH025SD541	
		250	KH025SD541	Preserved	-	
		400	KH040SD541	Removed	KH063SD541	
		630	KH063SD541	Preserved	-	
	3L + PEN	160	KH016SD551	Removed	KH025SD551	
		250	KH025SD551	Preserved	-	
		400	KH040SD551	Removed	KH063SD551	
		630	KH063SD551	Preserved	-	
		160	KH016SD542	Removed	No	
		250	KH025SD542	Removed	No	
3L + N + PE	400	KH040SD542	Removed	No		
	630	KH063SD542	Removed	No		
	3L + PEN	160	KH016SD552	Removed	No	
		250	KH025SD552	Removed	No	
400		KH040SD552	Removed	No		
630		KH063SD552	Preserved	No		
Muller Isolator	3L + N + PE	630	KH063SD841	Removed	No	
	3L + PEN	100	KH010SD85	Removed	KHB0250SE5	
		250	KH025SD85	Removed	KHB0250SE5	
		400	KH040SD85	Removed	KHB0630SE5R or KHB0630SE5L	
		630	KH063SD85	Removed	KHB0630SE5R or KHB0630SE5L	
Muller Isolator + Pelha	3L + PEN	400	KH063SD8502	Removed	KHB0630SE5R or KHB0630SE5L	
		630	KH063SD9502	Preserved	-	
Dumeco switch	-	-	KH0SD108919802	Removed	No	
			KH0SD108919803	Removed	No	
			KH0SD108920002	Removed	No	
			KH0SD108922201	Removed	No	
			KH0SD108922202	Removed	No	
			KH0SD107080401	Removed	No	
Other	3L + N + PE	100	KH0SD107076901	Removed	No	
		60	KH0SD107076901	Removed	No	
	3L + PEN	100	KH0SD107080402	Removed	No	
		60	KH0SD107076902	Removed	No	
-	60	KH0SD107076902	Removed	No		
	400	KH0SD1530710	Removed	No		

# Canalis KH substitution by Canalis KT

## Preserved KH tap-off units and substitution table

Bolted tap-off units						
Protection	Polarity	Rating	Catalogue number	Status	Substituted by	
Isolator and fuse carriers	3L + PE	160	KH016SB131	Removed	No	
			KH016SB132	Removed	No	
		250	KH025SB131	Removed	No	
			KH025SB132	Removed	No	
		400	KH040SB131	Removed	No	
			KH040SB132	Removed	No	
		630	KH063SB131	Removed	No	
			KH063SB132	Removed	No	
		1000	KH086SB131	Removed	No	
			KH086SB132	Removed	No	
			KH086SB132	Removed	No	
		3L + N + PE	160	KH016SB141	Removed	No
				KH016SB142	Removed	No
			250	KH025SB141	Removed	No
				KH025SB142	Removed	No
	400		KH040SB141	Removed	No	
			KH040SB142	Removed	No	
	630		KH063SB141	Removed	No	
			KH063SB142	Removed	No	
	1000		KH086SB141	Removed	No	
			KH086SB142	Removed	No	
			KH086SB142	Removed	No	
	3L + PEN		160	KH016SB151	Removed	No
				KH016SB152	Removed	No
			250	KH025SB151	Removed	No
				KH025SB152	Removed	No
		400	KH040SB151	Removed	No	
			KH040SB152	Removed	No	
		630	KH063SB151	Removed	No	
			KH063SB152	Removed	No	
		1000	KH086SB151	Removed	No	
			KH086SB152	Removed	No	
			KH086SB152	Removed	No	
		3L + NP + PE	160	KH016SB241	Removed	No
				KH016SB242	Removed	No
			250	KH025SB241	Removed	No
				KH025SB242	Removed	No
	400		KH040SB241	Removed	No	
			KH040SB242	Removed	No	
	630		KH063SB241	Removed	No	
			KH063SB242	Removed	No	
	1000		KH086SB241	Removed	No	
			KH086SB242	Removed	No	
			KH086SB242	Removed	No	
	Switch and fuse carriers		3L + PE	1000	KH086SB331	Removed
KH086SB332					Removed	No
3P + PE			250	KH025SB331	Removed	No
				KH025SB332	Removed	No
		400	KH040SB331	Removed	No	
			KH040SB332	Removed	No	
		630	KH063SB331	Removed	No	
			KH063SB332	Removed	No	
3P + PEN		1000	KH086SB351	Removed	No	
			KH086SB352	Removed	No	
3L + N + PE		250	KH025SB341	Removed	No	
			KH025SB342	Removed	No	
			KH025SB441	Removed	No	
			KH025SB442	Removed	No	
			400	KH040SB341	Removed	No
				KH040SB342	Removed	No
		KH040SB441		Removed	No	
		KH040SB442		Removed	No	
		630	KH063SB341	Removed	No	
			KH063SB342	Removed	No	
			KH063SB441	Removed	No	
			KH063SB442	Removed	No	
			1000	KH086SB341	Removed	No
				KH086SB342	Removed	No

# Canalis KH substitution by Canalis KT

## Preserved KH tap-off units and substitution table

### Canalis KTA

#### Bolted tap-off units

Protection	Polarity	Rating	Catalogue number	Status	Substituted by	
Switch and fuse carriers (con't)	3L + PEN	250	KH025SB351	Removed	No	
			KH025SB352	Removed	No	
		400	KH040SB351	Removed	No	
			KH040SB352	Removed	No	
		630	KH063SB351	Removed	No	
			KH063SB352	Removed	No	
Circuit breaker manuel	3L + PE	1000	KH086SB5311	Removed	No	
			KH086SB5312	Removed	No	
	3L + N + PE	250	KH025SB5411	Removed	No	
			KH025SB5412	Removed	No	
		400	KH040SB5411	Removed	No	
			KH040SB5412	Removed	No	
		630	KH063SB5411	Removed	No	
			KH063SB5412	Removed	No	
	1000	KH086SB5411	Removed	No		
		KH086SB5412	Removed	No		
	3L + PEN	250	KH025SB5511	Removed	No	
			KH025SB5512	Removed	No	
		400	KH040SB5511	Removed	No	
			KH040SB5512	Removed	No	
		630	KH063SB5511	Removed	No	
			KH063SB5512	Removed	No	
		1000	KH086SB5511	Removed	No	
			KH086SB5512	Removed	No	
	Circuit breaker electrical controle	3P + PEN	250	KH025SB5521	Removed	No
			400	KH040SB5521	Removed	No
630			KH063SB5521	Removed	No	
3L + N + PE		250	KH025SB5421	Removed	No	
			KH025SB5422	Removed	No	
		400	KH040SB5421	Removed	No	
			KH040SB5422	Removed	No	
		630	KH063SB5421	Removed	No	
			KH063SB5422	Removed	No	
3L + PEN		250	KH025SB5522	Removed	No	
			400	KH040SB5522	Removed	No
			630	KH063SB5522	Removed	No
Circuit breaker plug-out	3L + PEN	1000	KH040DD411	Removed	No	
			KH0SB1393108	Removed	No	
			KH0SB1393132	Removed	No	
Others	-	1000	KH0SA345794	Removed	No	
			KH0SB1041086	Removed	No	
		1500	KH0SA1088568	Removed	No	
			2000	KH0SA1088123	Removed	No

# Catalogue numbers and dimensions Canalis KH Plug-in tap-off units For Compact NSX circuit breakers

## Tap-off units for Compact NSX, fixed, front-connected circuit breakers, not equipped

DE402027

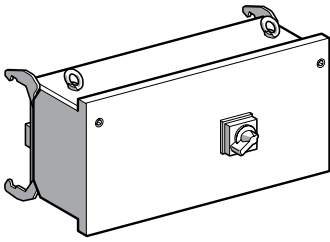

**KH0...SD5...**

The cover of the tap-off unit may be opened or closed only when the circuit breaker is in the Off position.

### Plug-in tap-off units for extended rotary

System earthing arrangement <sup>(1)</sup>		Busbar trunking			
		TT-TNS-TNC-IT	TNC		
		Tap-off unit			
		TT-TNS-TNS-IT	TNC		
Tap-off polarity		3L + N + PE	3L + PEN		
Tap-off diagram (e.g. circuit breaker protection)					
Rating (A)	Type of circuit breaker	Cable capacity (mm <sup>2</sup> )	Cable clamp on (mm)	Cat. no.	Weight (kg)
250 <sup>(2)</sup>	NSX250 N/H/L	1 x 150	30...70	<b>KH025SD541</b> <b>KH025SD551</b>	32.00
630 <sup>(2)</sup>	NSX630 N/H/L	2 x 300	2 x 30...70	<b>KH063SD541</b> <b>KH063SD551</b>	45.00

(1) These units can be fitted either on Canalis KTA or KHF.

(2) IP31 Rating.

DE401483

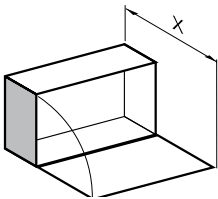

x = 520

DE401483

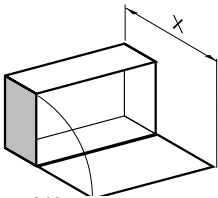

x = 646

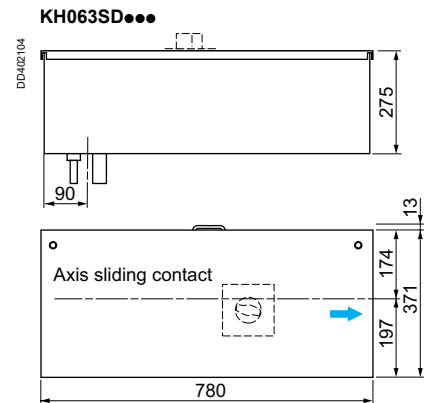
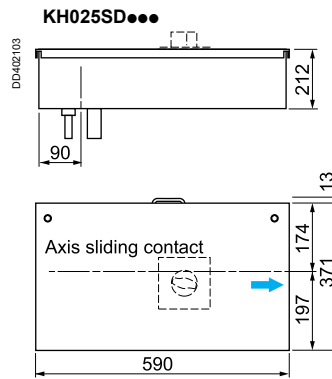

# Catalogue numbers and dimensions

## Canalis KH Plug-in tap-off units

### With switch-disconnectors for DIN fuses

#### Canalis KTA

#### SE - Tap-off units with switch-disconnector internal arc tested IEC 61-641

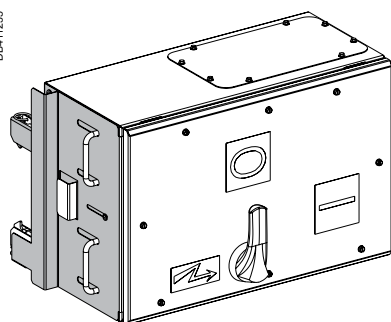

KHB0250SE●

The cover of the tap-off unit may be opened or closed only when the switch-disconnector is in the Off position.  
To be installed on KT EH type or on former KHF or KGF distribution length.

System earthing arrangement	Busbar trunking	TT-TNS-TNC-IT <sup>(1)</sup> TNC
	Tap-off unit	TT-TNS-TNS-IT <sup>(1)</sup> TNC
Tap-off polarity		3L + N + PE <sup>(2)</sup> 3L + PEN
Tap-off diagram (e.g. fuse protection)		

Rating (A)	Type of fuses	Connection	Max. size (mm <sup>2</sup> ) L or N / PE	Cable gland <sup>(3)</sup> (not supplied)	Cable exit side	Cat. no.	Cat. no.	Weight (kg)
250 <sup>(5)</sup>	DIN size 1	Terminals	1 x 150 / 1 x 75	ISO 32 max	Right & Left	<b>KHB0250SE4</b>		38
					Right & Left		<b>KHB0250SE5</b>	40

- (1) The neutral must be protected or not distributed (3L + PE) for the IT system.
- (2) Also suitable for tap-off unit 3L + PE (N not distributed, IT system also possible).
- (3) Maximum diameter by unipolar cable.
- (4) The tap-off unit is delivered with automatic clamps.
- (5) IP55 Rating.

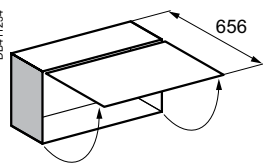

or

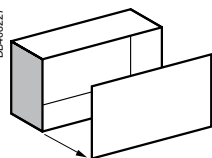

KHB0250SE●

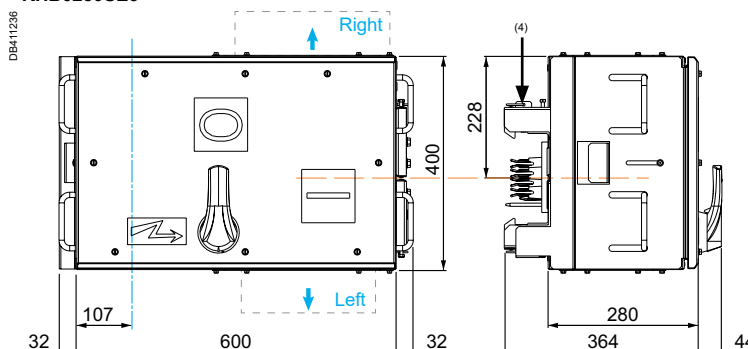

- ➔ Cable exit
- Center line of tap-off outlets
- Axis of Canalis KT
- - - Connection box to be fitted above or below

Option accessories	Cat. no.
Connecting box	<b>KTB0630ZA04</b>
Plate with 5 cable glands 24 to 40 mm	<b>KTB0000GP01</b>
Plate with 1 cable clamp 30 to 70 mm	<b>KTB0000GP02</b>
Plate with 2 cable clamps 30 to 70 mm	<b>KTB0000GP03</b>

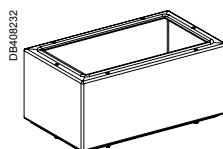

KTB0630ZA04

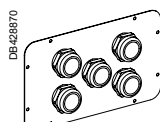

KTB0000GP01

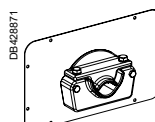

KTB0000GP02

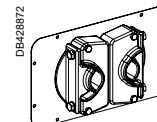

KTB0000GP03

# Catalogue numbers and dimensions

## Canalis KH Plug-in tap-off units

### With switch-disconnectors for DIN fuses



#### SE - Tap-off units with switch-disconnector internal arc tested IEC 61-641

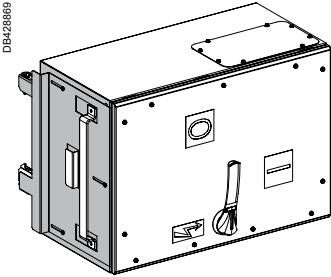

KHB0630SE●

The cover of the tap-off unit may be opened or closed only when the switch-disconnector is in the Off position.  
To be installed on KT EH type or on former KHF or KGF distribution length.

System earthing arrangement	Busbar trunking	TT-TNS-TNC-IT <sup>(1)</sup> TNC
	Tap-off unit	TT-TNS-TNS-IT <sup>(1)</sup> TNC
Tap-off polarity		3L + N + PE <sup>(2)</sup> 3L + PEN
Tap-off diagram (e.g. fuse protection)		

Rating (A)	Type of fuses	Connection	Max. size (mm <sup>2</sup> ) L or N / PE (kg)	Cable gland <sup>(3)</sup> (not supplied)	Cable exit side	Cat. no.	Cat. no.	Weight (kg)
630 <sup>(4)(6)</sup>	DIN size 3	Terminals	2 x 300 / 1 x 150	ISO 70 max.	Right	<b>KHB0630SE4R</b>		72
					Left	<b>KHB0630SE4L</b>		72
					Right		<b>KHB0630SE5R</b>	78
					Left		<b>KHB0630SE5L</b>	78

- (1) The neutral must be protected or not distributed (3L + PE) for the IT system.
- (2) Also suitable for tap-off unit 3L + PE (N not distributed, IT system also possible).
- (3) Maximum diameter by unipolar cable.
- (4) De-rating coefficient to apply: 0.87.
- (5) The tap-off unit is delivered with automatic clamps, the kit of connection bars is included in the reference and delivered in the box.
- (6) IP55 Rating.

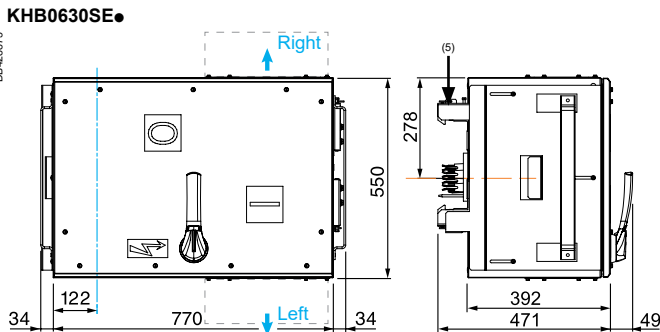
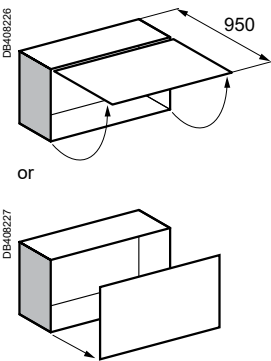

- Cable exit
- Center line of tap-off outlets
- Axis of Canalis KT
- Connection box to be fitted above or below

Option accessories	Cat. no.
Extension rotary handle	<b>KTB0630ZA03</b>
Connecting box	<b>KTB0630ZA04</b>
Plate with 5 cable glands 24 to 40 mm	<b>KTB0000GP01</b>
Plate with 1 cable clamp 30 to 70 mm	<b>KTB0000GP02</b>
Plate with 2 cable clamps 30 to 70 mm	<b>KTB0000GP03</b>

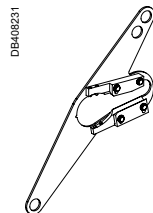

KTB0630ZA03

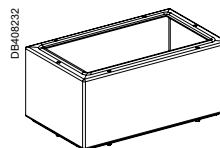

KTB0630ZA04

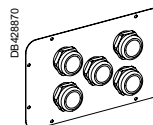

KTB0000GP01

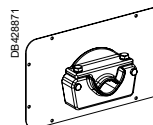

KTB0000GP02

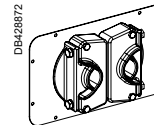

KTB0000GP03

# Catalogue numbers and dimensions

## Canalis KH Plug-in tap-off units

### With disconnecter Jean Muller

#### Canalis KTA

#### Tap-off units with disconnecter internal arc tested IEC 61-641

A

B

C

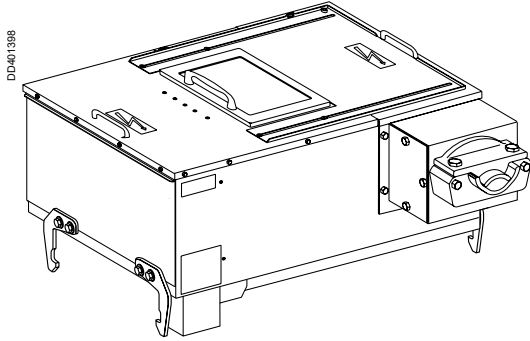

**KH040SD9502**

D

E

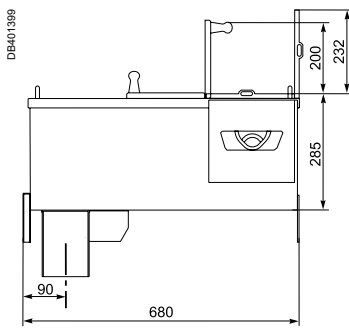

F

G

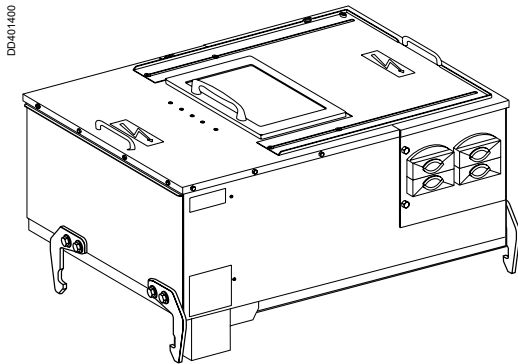

**KH063SD9502**

System earthing arrangement <sup>(1)</sup>	Busbar trunking	TNC			
	Tap-off unit	TNC			
Tap-off polarity	3L + PEN				
Tap-off diagram (e.g. fuse protection)					
lth (A)	Fuse size	Cable capacity (mm <sup>2</sup> )	Cat. no.	Weight (kg)	
400 <sup>(2)</sup>	With MULLER disconnecter	2	1 x 185	<b>KH040SD9502</b>	39.00
630 <sup>(2)</sup>	With MULLER disconnecter	3	2 x 185	<b>KH063SD9502</b>	46.00

(1) These units can be fitted either on Canalis KTA or KHF.  
 (2) IP43 Rating.

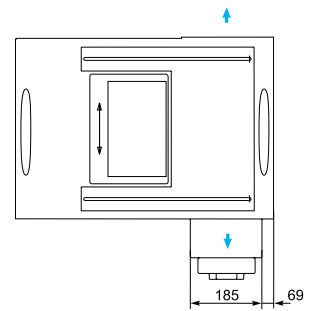
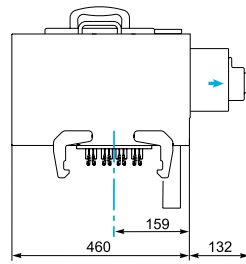

Connecting box is equipped with a 30 to 70 mm aluminium cable clamp.

DB408514

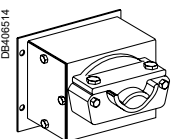

**KH040ZA07**

DB408515

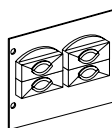

**KH063ZA07**

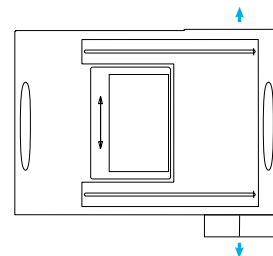
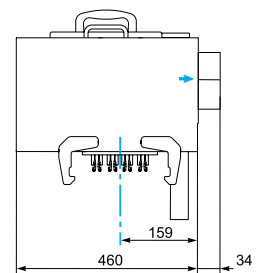
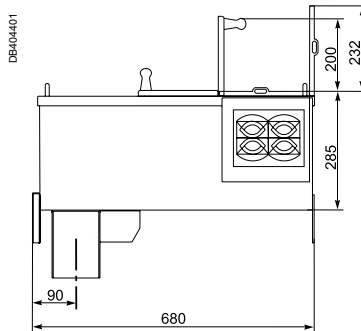

Connecting plate is equipped with 4 plastic cable clamps.

If 2 cables exit are needed, stand alone connecting box can be ordered.

Designation	Cat. no.
Connecting box for KH040SD9502 with a 30 to 70 mm aluminium cable clamp	<b>KH040ZA07</b>
Connecting plate for KH063SD9502 with 4 plastic clamps	<b>KH063ZA07</b>

# Expansion of a Canalis KH line by means of Canalis KT

DB401536

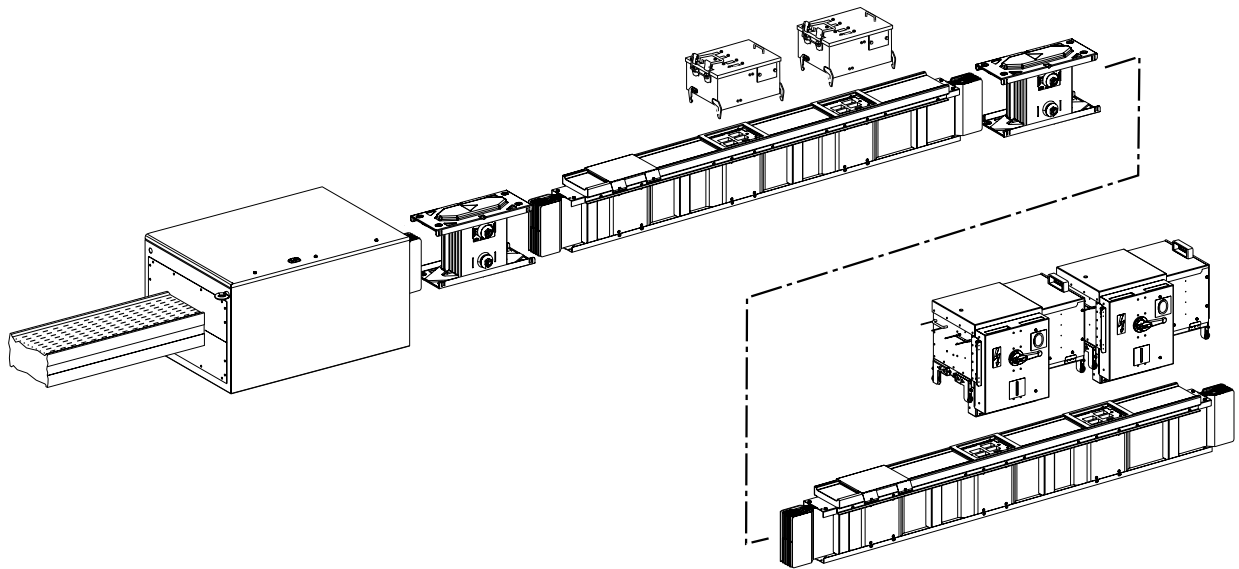

- A
- B
- C
- D
- E
- F
- G

# Expansion of a Canalis KH line by means of Canalis KT with a T-piece tap-off unit

## Canalis KTA

- A
- B
- C
- D
- E
- F
- G

DB401534

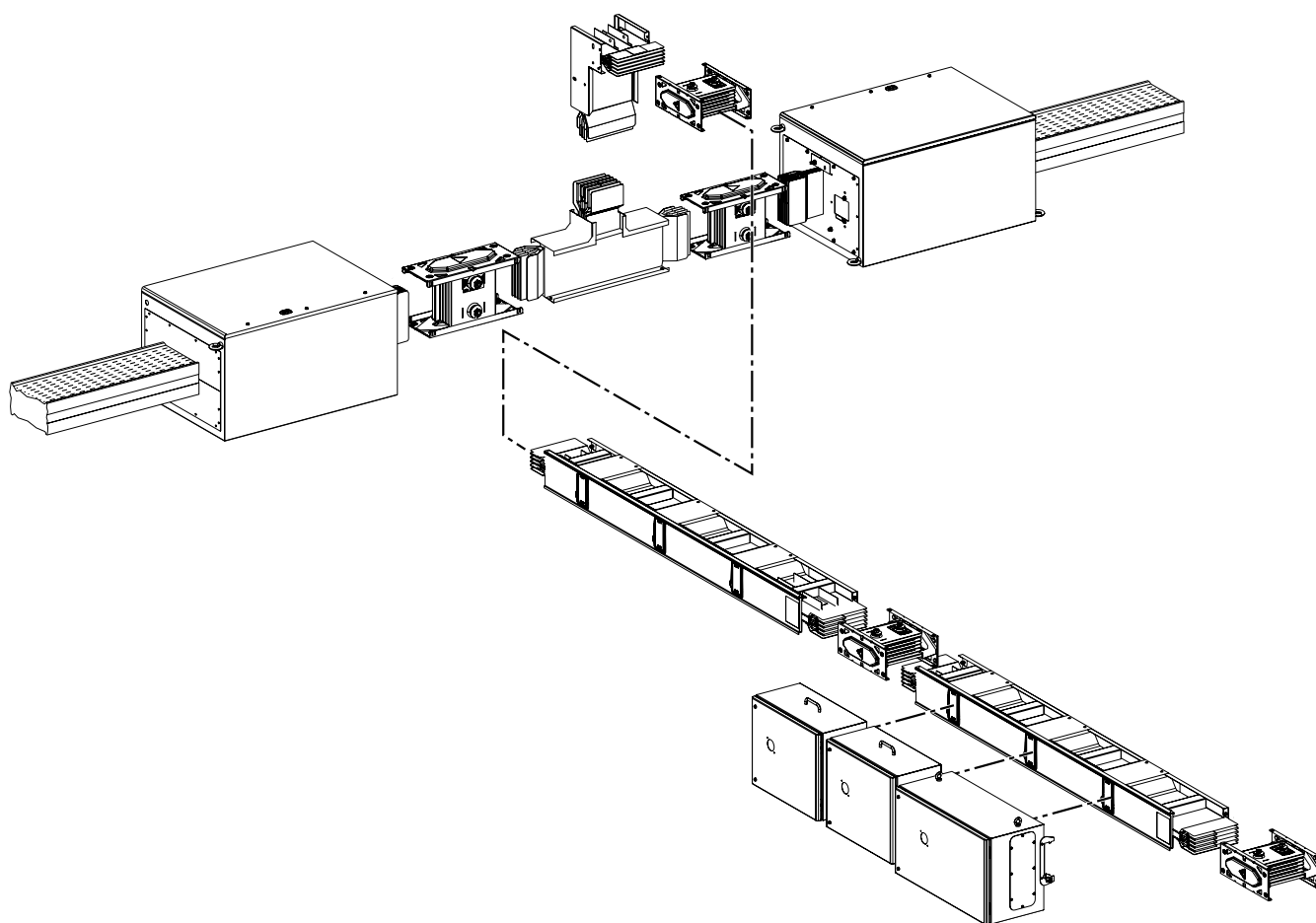

# Mid KT line power supply with KH tap-off units installed

DB401497

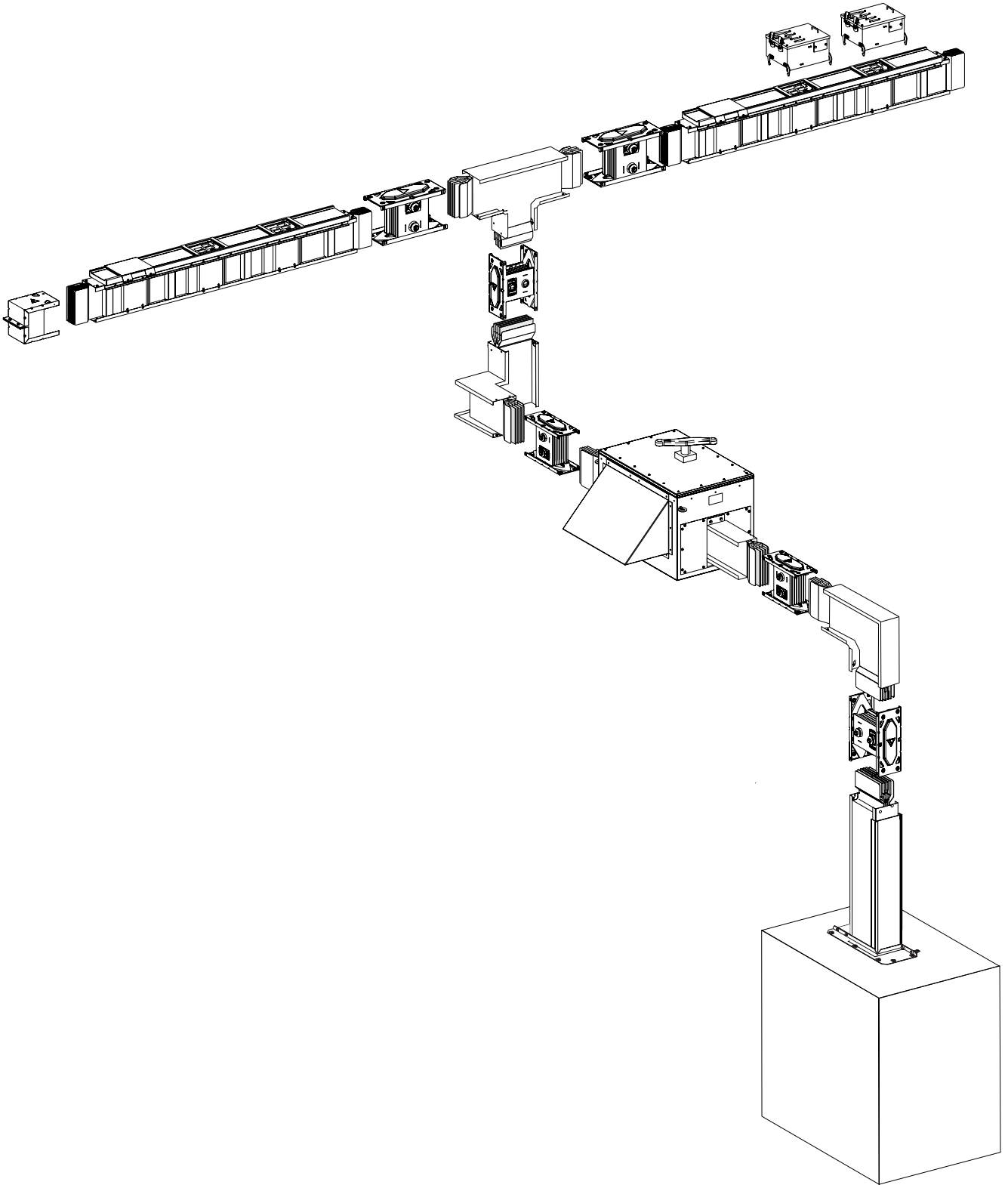

- A
- B
- C
- D
- E
- F
- G

A

B

C

D

E

F

G

# Design guide

Introduction	3
Presentation and description	23
Catalogue numbers and dimensions	47
<b>Characteristics</b>	<b>144</b>
Canalis KTA 3L + PE	144
Canalis KTA 3L + N + PE	145
Canalis KTA 3L + N + PER	146
<b>Other characteristics</b>	<b>148</b>
<b>Determining the rating</b>	<b>150</b>
Providing power distribution using Canalis	150
<b>Sizing the busbar trunking</b>	<b>152</b>
<b>Protection of circuits supplied by several paralleled transformers</b>	<b>154</b>
<b>Coordination</b>	<b>156</b>
Protection of busbar trunking against overloads	156
Protection against short-circuits	158
<b>Circuit breaker / busbar trunking coordination</b>	<b>159</b>
Non-limiting or time-delayed circuit breaker	159
Limiter circuit breaker	160
<b>Protecting busbar trunking with a Compact NS circuit breaker</b>	<b>161</b>
<b>Selection guide</b>	<b>162</b>
<b>Degree of protection</b>	<b>168</b>
<b>Harmonic currents</b>	<b>170</b>
<b>Direct current</b>	<b>172</b>
<b>Frequencies</b>	<b>174</b>
400 Hz	174
<b>Measurements and metering</b>	<b>175</b>
Canalis part of StruxureWare	175
<b>Fire resistance</b>	<b>176</b>
<b>Seismic resistance</b>	<b>178</b>
<b>Testing and commissioning procedure</b>	<b>180</b>
Installation guide	185
Recommendations	243
Index	248

# Characteristics

## Canalis KTA 3L + PE

### Canalis KTA

#### Characteristics of run sections

	Symbol	Unit	Busbar trunking rating (A)								
			800	1000	1250	1600	2000	2500	3200	4000	5000
<b>General characteristics</b>			IEC/EN 61439-6								
Compliance with standards			55								
Protection degree	IP		Any installation (indoors only) is possible for the busbar trunking: edgewise, flat or vertical. See test condition, page 168.								
Shock resistance	IK		08								
Nominal rated current at an ambient temperature of 35°C	I <sub>nc</sub>	A	800	1000	1250	1600	2000	2500	3200	4000	5000
Rated insulation voltage	U <sub>i</sub>	V	1000								
Rated operating voltage	U <sub>e</sub>	V	1000								
Operating frequency	f	Hz	50 / 60 (for 60 to 400 Hz AC or for DC, consult us)								

#### Short-circuit current withstand

##### Standard version 3L + PE

	Symbol	Unit	31	50	50	65	110	113	86	90	120
Allowable rated short-time withstand current (t = 1 s)	I <sub>cw</sub>	kA	31	50	50	65	110	113	86	90	120
Allowable rated peak current	I <sub>pk</sub>	kA	64	110	110	143	242	248	189	198	264
Maximum thermal stress I <sup>2</sup> t (t = 1 s)	I <sup>2</sup> t	A <sup>2</sup> s 10 <sup>6</sup>	961	2500	2500	4225	12100	12769	7396	8100	14400

Ratings 2000 and 2500 A are equipped in standard version with side reinforcements.

#### Conductor characteristics

##### Phase conductors

	Symbol	Unit	0.079	0.057	0.046	0.035	0.028	0.023	0.017	0.014	0.0115
Average resistance at an ambient temperature of 20°C	R <sub>20</sub>	mΩ/m	0.079	0.057	0.046	0.035	0.028	0.023	0.017	0.014	0.0115
Average resistance at I <sub>nc</sub> and at 35°C	R <sub>1</sub>	mΩ/m	0.096	0.069	0.056	0.042	0.034	0.028	0.021	0.017	0.014
Average reactance at I <sub>nc</sub> and at 35°C and at 50 Hz	X <sub>1</sub>	mΩ/m	0.018	0.016	0.015	0.013	0.011	0.008	0.007	0.007	0.004
Average impedance at I <sub>nc</sub> and at 35°C and at 50 Hz	Z <sub>1</sub>	mΩ/m	0.097	0.071	0.058	0.044	0.035	0.029	0.022	0.018	0.0145

##### PE = casing

	Symbol	Unit	0.223	0.198	0.184	0.162	0.144	0.130	0.108	0.094	0.065
Average resistance at an ambient temperature of 20°C		mΩ/m	0.223	0.198	0.184	0.162	0.144	0.130	0.108	0.094	0.065
Casing (equivalent copper cross-section)		mm <sup>2</sup>	109	117	125	137	145	157	163	171	313

#### Fault loop characteristics

Symmetrical components method	Ph/PE at 20°C	Average resistance	R <sub>0 ph/PE</sub>	mΩ/m	0.891	0.752	0.657	0.554	0.479	0.425	0.352	0.300	0.213
		Average reactance	X <sub>0 ph/PE</sub>	mΩ/m	0.762	0.586	0.478	0.364	0.286	0.231	0.170	0.131	0.116
		Average impedance	Z <sub>0 ph/PE</sub>	mΩ/m	1.172	0.953	0.812	0.663	0.558	0.484	0.391	0.328	0.242
Impedance method	At 20°C	Average resistance	Ph/Ph R <sub>b0 ph/ph</sub>	mΩ/m	0.160	0.115	0.097	0.073	0.059	0.051	0.038	0.031	0.026
		Average reactance	Ph/PE R <sub>b0 ph/PE</sub>	mΩ/m	0.585	0.489	0.395	0.318	0.263	0.226	0.179	0.147	0.114
	At I <sub>nc</sub> and at 35°C	Average resistance	Ph/Ph R <sub>b1 ph/ph</sub>	mΩ/m	0.193	0.140	0.120	0.091	0.075	0.066	0.049	0.039	0.033
Average reactance		Ph/PE R <sub>b1 ph/PE</sub>	mΩ/m	0.706	0.595	0.490	0.394	0.333	0.290	0.229	0.188	0.145	
	At I <sub>nc</sub> and at 35°C and at 50 Hz	Average reactance	Ph/Ph X <sub>b ph/ph</sub>	mΩ/m	0.040	0.029	0.024	0.019	0.015	0.013	0.010	0.008	0.007
Average impedance		Ph/PE X <sub>b ph/PE</sub>	mΩ/m	0.426	0.329	0.275	0.212	0.170	0.141	0.106	0.084	0.071	

#### Other characteristics

##### Voltage drop

Line-to-line voltage drop, in volts (V) per 100 metres and per amp (A) at 50 Hz with load spread over the run. For the case of loads concentrated at the end of a run, the voltage drops are double those shown in this table.

This calculation table applies to three-phase loads. For single-phase loads, the voltage drop given in the table is divided by 1.732.

For a cosine φ of		Unit	0.0083	0.0060	0.0049	0.0037	0.0029	0.0024	0.0018	0.0015	0.0012
1	V/100 m/A		0.0083	0.0060	0.0049	0.0037	0.0029	0.0024	0.0018	0.0015	0.0012
0.9	V/100 m/A		0.0081	0.0060	0.0050	0.0038	0.0030	0.0025	0.0019	0.0016	0.00125
0.8	V/100 m/A		0.0076	0.0056	0.0047	0.0036	0.0029	0.0024	0.0018	0.0015	0.0012
0.7	V/100 m/A		0.0069	0.0052	0.0043	0.0034	0.0027	0.0022	0.0017	0.0015	0.0011

##### Average weight

3L + PE	kg/m	12	14	16	19	22	25	31	38	50
		12	14	16	19	22	25	31	38	50

##### Fire load value

	kWh/m	2.1	2.9	3.2	3.9	5.7	6.2	8.9	11.2	12.4
		2.1	2.9	3.2	3.9	5.7	6.2	8.9	11.2	12.4

##### Radiated magnetic field

Radiated magnetic field strength 1 metre from the trunking	B	μT	0.4	0.5	0.75	0.9	1.3	1.6	2.1	3.0	3.8
			0.4	0.5	0.75	0.9	1.3	1.6	2.1	3.0	3.8

### Characteristics of run sections

	Symbol	Unit	Busbar trunking rating (A)								
			800	1000	1250	1600	2000	2500	3200	4000	5000
<b>General characteristics</b>											
Compliance with standards			IEC/EN 61439-6								
Protection degree	IP		55 Any installation (indoors only) is possible for the busbar trunking: edgewise, flat or vertical. See test condition, page 168.								
Shock resistance	IK		08								
Nominal rated current at an ambient temperature of 35°C	Inc	A	800	1000	1250	1600	2000	2500	3200	4000	5000
Rated insulation voltage	Ui	V	1000								
Rated operating voltage	Ue	V	1000								
Operating frequency	f	Hz	50 / 60 (for 60 to 400 Hz AC or for DC, consult us)								

### Short-circuit current withstand

#### Standard version 3L + N + PE

Allowable rated short-time withstand current (t = 1 s)	I <sub>cw</sub>	kA	31	50	50	65	70	80	86	90	120
Allowable rated peak current	I <sub>pk</sub>	kA	64	110	110	143	154	176	189	198	264
Maximum thermal stress I <sup>2</sup> t (t = 1 s)	I <sup>2</sup> t	A <sup>2</sup> s 10 <sup>6</sup>	961	2500	2500	4225	4900	6400	7396	8100	14400

#### Reinforced version 3L + N + PE for 2500 A and 3200 A only

Allowable rated short-time withstand current (t = 1 s)	I <sub>cw</sub>	kA	-	-	-	-	-	113	113	-	-
Allowable rated peak current	I <sub>pk</sub>	kA	-	-	-	-	-	248	248	-	-
Maximum thermal stress	I <sup>2</sup> t	A <sup>2</sup> s 10 <sup>6</sup>	-	-	-	-	-	12769	12769	-	-

### Conductor characteristics

#### Phase conductors

Average resistance at an ambient temperature of 20°C	R <sub>20</sub>	mΩ/m	0.079	0.057	0.046	0.035	0.028	0.023	0.017	0.014	0.0115
Average resistance at Inc and at 35°C	R <sub>1</sub>	mΩ/m	0.096	0.069	0.056	0.042	0.034	0.028	0.021	0.017	0.014
Average reactance at Inc and at 35°C and at 50 Hz	X <sub>1</sub>	mΩ/m	0.018	0.016	0.015	0.013	0.011	0.008	0.007	0.007	0.004
Average impedance at Inc and at 35°C and at 50 Hz	Z <sub>1</sub>	mΩ/m	0.097	0.071	0.058	0.044	0.035	0.029	0.022	0.018	0.0145

#### PE = casing

Average resistance at an ambient temperature of 20°C		mΩ/m	0.223	0.198	0.184	0.162	0.144	0.130	0.108	0.094	0.065
Casing (equivalent copper cross-section)		mm <sup>2</sup>	109	117	125	137	145	157	163	171	313

### Fault loop characteristics

Symmetrical components method	Ph/N at 20°C	Average resistance	R <sub>0 ph/N</sub>	mΩ/m	0.345	0.248	0.209	0.159	0.128	0.111	0.083	0.066	0.056		
		Average reactance	X <sub>0 ph/N</sub>	mΩ/m	0.143	0.103	0.087	0.067	0.054	0.046	0.035	0.028	0.023		
		Average impedance	Z <sub>0 ph/N</sub>	mΩ/m	0.373	0.269	0.226	0.172	0.139	0.120	0.090	0.072	0.060		
	Ph/PE at 20°C	Average resistance	R <sub>0 ph/PE</sub>	mΩ/m	0.891	0.752	0.657	0.554	0.479	0.425	0.352	0.300	0.213		
		Average reactance	X <sub>0 ph/PE</sub>	mΩ/m	0.762	0.586	0.478	0.364	0.286	0.231	0.170	0.131	0.116		
		Average impedance	Z <sub>0 ph/PE</sub>	mΩ/m	1.172	0.953	0.812	0.663	0.558	0.484	0.391	0.328	0.242		
Impedance method	At 20°C	Average resistance	Ph/Ph	R <sub>b0 ph/ph</sub>	mΩ/m	0.160	0.115	0.097	0.073	0.059	0.051	0.038	0.031	0.026	
			Ph/N	R <sub>b0 ph/N</sub>	mΩ/m	0.161	0.115	0.097	0.074	0.059	0.052	0.039	0.031	0.026	
			Ph/PE	R <sub>b0 ph/PE</sub>	mΩ/m	0.585	0.489	0.395	0.318	0.263	0.226	0.179	0.147	0.114	
		At Inc and at 35°C	Average resistance	Ph/Ph	R <sub>b1 ph/ph</sub>	mΩ/m	0.193	0.140	0.120	0.091	0.075	0.066	0.049	0.039	0.033
				Ph/N	R <sub>b1 ph/N</sub>	mΩ/m	0.194	0.140	0.120	0.092	0.075	0.066	0.049	0.039	0.033
				Ph/PE	R <sub>b1 ph/PE</sub>	mΩ/m	0.706	0.595	0.490	0.394	0.333	0.290	0.229	0.188	0.145
	At Inc and at 35°C and at 50 Hz	Average reactance	Ph/Ph	X <sub>b ph/ph</sub>	mΩ/m	0.040	0.029	0.024	0.019	0.015	0.013	0.010	0.008	0.007	
			Ph/N	X <sub>b ph/N</sub>	mΩ/m	0.064	0.047	0.040	0.030	0.024	0.021	0.016	0.013	0.011	
			Ph/PE	X <sub>b ph/PE</sub>	mΩ/m	0.426	0.329	0.275	0.212	0.170	0.141	0.106	0.084	0.071	

### Other characteristics

#### Voltage drop

Line-to-line voltage drop, in volts (V) per 100 metres and per amp (A) at 50 Hz with load spread over the run. For the case of loads concentrated at the end of a run, the voltage drops are double those shown in this table.

This calculation table applies to three-phase loads. For single-phase loads, the voltage drop given in the table is divided by 1.732.

For a cosine φ of	1	V/100 m/A	0.0083	0.0060	0.0049	0.0037	0.0029	0.0024	0.0018	0.0015	0.0012
	0.9	V/100 m/A	0.0081	0.0060	0.0050	0.0038	0.0030	0.0025	0.0019	0.0016	0.00125
	0.8	V/100 m/A	0.0076	0.0056	0.0047	0.0036	0.0029	0.0024	0.0018	0.0015	0.0012
	0.7	V/100 m/A	0.0069	0.0052	0.0043	0.0034	0.0027	0.0022	0.0017	0.0015	0.0011

#### Average weight

3L + N + PE	kg/m	13	16	18	22	26	30	37	45	60
-------------	------	----	----	----	----	----	----	----	----	----

#### Fire load value

	kWh/m	2.5	3.6	4.1	5.9	7.3	8.0	11.5	14.4	16
--	-------	-----	-----	-----	-----	-----	-----	------	------	----

#### Radiated magnetic field

Radiated magnetic field strength 1 metre from the trunking	B	μT	0.4	0.5	0.75	0.9	1.3	1.6	2.1	3.0	3.8
--	---	----	-----	-----	------	-----	-----	-----	-----	-----	-----

## Characteristics

## Canalis KTA 3L + N + PER

With an internal aluminium PE conductor

## Canalis KTA

## Characteristics of run sections

	Symbol	Unit	Busbar trunking rating (A)								
			800	1000	1250	1600	2000	2500	3200	4000	5000
<b>General characteristics</b>			IEC/EN 61439-6								
Compliance with standards			IEC/EN 61439-6								
Protection degree	IP		55								
			Any installation (indoors only) is possible for the busbar trunking: edgewise, flat or vertical. See test condition, page 168.								
Shock resistance	IK		08								
Nominal rated current at an ambient temperature of 35°C	Inc	A	800	1000	1250	1600	2000	2500	3200	4000	5000
Rated insulation voltage	Ui	V	1000								
Rated operating voltage	Ue	V	1000								
Operating frequency	f	Hz	50/60 (for 60 to 400 Hz AC or for DC, consult us)								

## Short-circuit current withstand

	Symbol	Unit	800	1000	1250	1600	2000	2500	3200	4000	5000
Allowable rated short-time withstand current (t = 1 s)	I <sub>cw</sub>	kA	31	50	50	65	70	80	86	90	120
Allowable rated peak current	I <sub>pk</sub>	kA	64	110	110	143	154	176	189	198	264
Maximum thermal stress I <sup>2</sup> t (t = 1 s)	I <sup>2</sup> t	A <sup>2</sup> s 10 <sup>6</sup>	961	2500	2500	4225	4900	6400	7396	8100	14400

## Conductor characteristics

## Phase conductors

	Symbol	Unit	800	1000	1250	1600	2000	2500	3200	4000	5000
Average resistance at an ambient temperature of 20°C	R <sub>20</sub>	mΩ/m	0.079	0.057	0.046	0.035	0.028	0.023	0.017	0.014	0.0115
Average resistance at Inc and at 35°C	R <sub>1</sub>	mΩ/m	0.096	0.069	0.056	0.042	0.034	0.028	0.021	0.017	0.014
Average reactance at Inc and at 35°C and at 50 Hz	X <sub>1</sub>	mΩ/m	0.018	0.016	0.015	0.013	0.011	0.008	0.007	0.007	0.004
Average impedance at Inc and at 35°C and at 50 Hz	Z <sub>1</sub>	mΩ/m	0.097	0.071	0.058	0.044	0.035	0.029	0.022	0.018	0.0145

## PE = internal aluminium protective conductor

	Symbol	Unit	800	1000	1250	1600	2000	2500	3200	4000	5000
Average resistance at an ambient temperature of 20°C		mΩ/m	0.067	0.054	0.047	0.038	0.032	0.029	0.023	0.019	0.014
Aluminium cross-section		mm <sup>2</sup>	210	300	360	480	600	720	960	1200	1440

## Fault loop characteristics

Symmetrical components method	Ph/N at 20°C	Average resistance	R <sub>0 ph/N</sub>	mΩ/m	0.345	0.248	0.209	0.159	0.128	0.111	0.083	0.066	0.056	
		Average reactance	X <sub>0 ph/N</sub>	mΩ/m	0.143	0.103	0.087	0.067	0.054	0.046	0.035	0.028	0.023	0.023
	Average impedance	Z <sub>0 ph/N</sub>	mΩ/m	0.373	0.269	0.226	0.172	0.139	0.120	0.090	0.072	0.060	0.060	
Ph/PE at 20°C	Average resistance	R <sub>0 ph/PE</sub>	mΩ/m	0.506	0.360	0.303	0.230	0.184	0.162	0.120	0.096	0.081	0.081	
	Average reactance	X <sub>0 ph/PE</sub>	mΩ/m	0.236	0.168	0.142	0.108	0.087	0.075	0.057	0.045	0.038	0.038	
	Average impedance	Z <sub>0 ph/PE</sub>	mΩ/m	0.559	0.398	0.334	0.254	0.204	0.178	0.133	0.106	0.090	0.090	
Impedance method	At 20°C	Average resistance	Ph/Ph R <sub>b0 ph/ph</sub>	mΩ/m	0.160	0.115	0.097	0.073	0.059	0.051	0.038	0.031	0.026	0.026
			Ph/N R <sub>b0 ph/N</sub>	mΩ/m	0.161	0.115	0.097	0.074	0.059	0.052	0.039	0.031	0.026	0.026
			Ph/PE R <sub>b0 ph/PE</sub>	mΩ/m	0.183	0.132	0.112	0.085	0.068	0.060	0.045	0.035	0.030	0.030
At Inc and at 35°C	Average resistance	Ph/Ph R <sub>b1 ph/ph</sub>	mΩ/m	0.193	0.140	0.120	0.091	0.075	0.066	0.049	0.039	0.033	0.033	
		Ph/N R <sub>b1 ph/N</sub>	mΩ/m	0.194	0.140	0.120	0.092	0.075	0.066	0.049	0.039	0.033	0.033	
		Ph/PE R <sub>b1 ph/PE</sub>	mΩ/m	0.221	0.160	0.137	0.106	0.087	0.078	0.058	0.037	0.040	0.040	
At Inc and at 35°C and at 50 Hz	Average reactance	Ph/Ph X <sub>b ph/ph</sub>	mΩ/m	0.040	0.029	0.024	0.019	0.015	0.013	0.010	0.008	0.007	0.007	
		Ph/N X <sub>b ph/N</sub>	mΩ/m	0.064	0.047	0.040	0.030	0.024	0.021	0.016	0.013	0.011	0.011	
		Ph/PE X <sub>b ph/PE</sub>	mΩ/m	0.095	0.069	0.058	0.044	0.036	0.031	0.023	0.019	0.016	0.016	

## Other characteristics

## Voltage drop

Line-to-line voltage drop, in volts (V) per 100 metres and per amp (A) at 50 Hz with load spread over the run. For the case of loads concentrated at the end of a run, the voltage drops are double those shown in this table.

This calculation table applies to three-phase loads. For single-phase loads, the voltage drop given in the table is divided by 1.732.

For a cosine φ of		Unit	800	1000	1250	1600	2000	2500	3200	4000	5000
1	V/100 m/A		0.0083	0.0060	0.0049	0.0037	0.0029	0.0024	0.0018	0.0015	0.0012
0.9	V/100 m/A		0.0081	0.0060	0.0050	0.0038	0.0030	0.0025	0.0019	0.0016	0.00125
0.8	V/100 m/A		0.0076	0.0056	0.0047	0.0036	0.0029	0.0024	0.0018	0.0015	0.0012
0.7	V/100 m/A		0.0069	0.0052	0.0043	0.0034	0.0027	0.0022	0.0017	0.0015	0.0011

## Average weight

3L + N + PER	kg/m	800	1000	1250	1600	2000	2500	3200	4000	5000
		15	19	21	26	31	36	46	56	72

## Fire load value

	kWh/m	800	1000	1250	1600	2000	2500	3200	4000	5000
		2.5	3.6	4.1	5.9	7.3	8.0	11.5	14.4	16

## Radiated magnetic field

Radiated magnetic field strength 1 metre from the trunking	B	μT	800	1000	1250	1600	2000	2500	3200	4000	5000
			0.4	0.5	0.75	0.9	1.3	1.6	2.1	3.0	3.8

## Characteristics

## Canalis KTA 3L + N + PER

With an internal copper PE conductor and reinforced l<sub>cw</sub>

## Characteristics of run sections

	Symbol	Unit	Busbar trunking rating (A)								
			800	1000	1250	1600	2000	2500	3200	4000	5000
<b>General characteristics</b>			IEC/EN 61439-6								
Compliance with standards			IEC/EN 61439-6								
Protection degree	IP		55								
			Any installation (indoors only) is possible for the busbar trunking: edgewise, flat or vertical. See test condition, page 168.								
Shock resistance	IK		08								
Nominal rated current at an ambient temperature of 35°C	I <sub>nc</sub>	A	800	1000	1250	1600	2000	2500	3200	4000	5000
Rated insulation voltage	U <sub>i</sub>	V	1000								
Rated operating voltage	U <sub>e</sub>	V	1000								
Operating frequency	f	Hz	50 / 60 (for 60 to 400 Hz AC or for DC, consult us)								

## Short-circuit current withstand

Allowable rated short-time withstand current (t = 1 s)	I <sub>cw</sub>	kA	35	65	65	85	110	113	113	120	120
Allowable rated peak current	I <sub>pk</sub>	kA	73	143	143	187	242	248	248	264	264
Maximum thermal stress	I <sup>2</sup> t	A <sup>2</sup> .s.10 <sup>6</sup>	1225	4225	4225	7225	12100	12769	12769	14400	14400

## Conductor characteristics

## Phase conductors

Average resistance at an ambient temperature of 20°C	R <sub>20</sub>	mΩ/m	0.079	0.057	0.046	0.035	0.028	0.023	0.017	0.014	0.0115
Average resistance at I <sub>nc</sub> and at 35°C	R <sub>1</sub>	mΩ/m	0.096	0.069	0.056	0.042	0.034	0.028	0.021	0.017	0.014
Average reactance at I <sub>nc</sub> and at 35°C and at 50 Hz	X <sub>1</sub>	mΩ/m	0.018	0.016	0.015	0.013	0.011	0.008	0.007	0.007	0.004
Average impedance at I <sub>nc</sub> and at 35°C and at 50 Hz	Z <sub>1</sub>	mΩ/m	0.097	0.071	0.058	0.044	0.035	0.029	0.022	0.018	0.0145

## PE = internal copper protective conductor

Average resistance at an ambient temperature of 20°C		mΩ/m	0.051	0.040	0.035	0.027	0.022	0.019	0.014	0.012	0.010
Copper cross-section		mm <sup>2</sup>	210	300	360	480	600	720	960	1200	1440

## Fault loop characteristics

Symmetrical components method	Ph/N at 20°C	Average resistance	R <sub>0 ph/N</sub>	mΩ/m	0.345	0.248	0.209	0.159	0.128	0.111	0.083	0.066	0.056	
		Average reactance	X <sub>0 ph/N</sub>	mΩ/m	0.143	0.103	0.087	0.067	0.054	0.046	0.035	0.028	0.023	
		Average impedance	Z <sub>0 ph/N</sub>	mΩ/m	0.373	0.269	0.226	0.172	0.139	0.120	0.090	0.072	0.060	
	Ph/PE at 20°C	Average resistance	R <sub>0 ph/PE</sub>	mΩ/m	0.254	0.191	0.165	0.129	0.105	0.090	0.069	0.056	0.045	
		Average reactance	X <sub>0 ph/PE</sub>	mΩ/m	0.111	0.087	0.077	0.062	0.017	0.045	0.035	0.029	0.023	
		Average impedance	Z <sub>0 ph/PE</sub>	mΩ/m	0.277	0.210	0.182	0.143	0.107	0.100	0.077	0.063	0.051	
Impedance method	At 20°C	Average resistance	Ph/Ph	R <sub>b0 ph/ph</sub>	mΩ/m	0.160	0.115	0.097	0.073	0.059	0.051	0.038	0.031	0.026
			Ph/N	R <sub>b0 ph/N</sub>	mΩ/m	0.161	0.115	0.097	0.074	0.059	0.052	0.039	0.031	0.026
			Ph/PE	R <sub>b0 ph/PE</sub>	mΩ/m	0.138	0.101	0.086	0.066	0.053	0.045	0.033	0.028	0.023
	At I <sub>nc</sub> and at 35°C	Average resistance	Ph/Ph	R <sub>b1 ph/ph</sub>	mΩ/m	0.193	0.140	0.120	0.091	0.075	0.066	0.049	0.039	0.033
			Ph/N	R <sub>b1 ph/N</sub>	mΩ/m	0.194	0.140	0.120	0.092	0.075	0.066	0.049	0.039	0.033
			Ph/PE	R <sub>b1 ph/PE</sub>	mΩ/m	0.166	0.123	0.105	0.080	0.067	0.057	0.042	0.036	0.029
	At I <sub>nc</sub> and at 35°C and at 50 Hz	Average reactance	Ph/Ph	X <sub>b ph/ph</sub>	mΩ/m	0.040	0.029	0.024	0.019	0.015	0.013	0.010	0.008	0.007
			Ph/N	X <sub>b ph/N</sub>	mΩ/m	0.064	0.047	0.040	0.030	0.024	0.021	0.016	0.013	0.011
			Ph/PE	X <sub>b ph/PE</sub>	mΩ/m	0.047	0.037	0.032	0.026	0.022	0.019	0.014	0.012	0.010

## Other characteristics

## Voltage drop

Line-to-line voltage drop, in volts (V) per 100 metres and per amp (A) at 50 Hz with load spread over the run. For the case of loads concentrated at the end of a run, the voltage drops are double those shown in this table.

This calculation table applies to three-phase loads. For single-phase loads, the voltage drop given in the table is divided by 1.732.

For a cosine φ of	1	V/100 m/A	0.0083	0.0060	0.0049	0.0037	0.0029	0.0024	0.0018	0.0015	0.0012
	0.9	V/100 m/A	0.0081	0.0060	0.0050	0.0038	0.0030	0.0025	0.0019	0.0016	0.00125
	0.8	V/100 m/A	0.0076	0.0056	0.0047	0.0036	0.0029	0.0024	0.0018	0.0015	0.0012
	0.7	V/100 m/A	0.0069	0.0052	0.0043	0.0034	0.0027	0.0022	0.0017	0.0015	0.0011

## Average weight

3L + N + PER	kg/m	15	19	21	26	31	36	46	56	72
--------------	------	----	----	----	----	----	----	----	----	----

## Fire load value

	kWh/m	2.5	3.6	4.1	5.9	7.3	8.0	11.5	14.4	16
--	-------	-----	-----	-----	-----	-----	-----	------	------	----

## Radiated magnetic field

Radiated magnetic field strength 1 metre from the trunking	B	μT	0.4	0.5	0.75	0.9	1.3	1.6	2.1	3.0	3.8
--	---	----	-----	-----	------	-----	-----	-----	-----	-----	-----

### Canalis KTA

#### Characteristics of run sections

#### Other characteristics

Choice of products when harmonics are present (see "harmonic currents" for more details).

THD ≤ 15 %	15 % < THD ≤ 33 %	THD > 33 %	Busbar trunking	Rating (A)
800	630	500	KTA	800
1000	800	630	KTA	1000
1200	1000	800	KTA	1250
1600	1250	1000	KTA	1600
2000	1600	1250	KTA	2000
2500	2000	1600	KTA	2500
3200	<b>2500</b>	2000	KTA	3200
4000	3200	2500	KTA	4000
5000	4000	3200	KTA	5000

Example. For a total rms current of 2356 A (estimation based on power drawn by loads, including harmonics), the operational current is 2500 A. THD is estimated at 30 %. The appropriate trunking is KTA 3200 A.

#### Allowable current as a function of ambient temperature

Canalis busbar trunking is sized to operate at an ambient air which does not exceed +40°C and its average over a period of 24 h does not exceed +35°C. Above this value, the busbar trunking must be derated.

Where k1 = ambient temperature derating coefficient.

	Symbol	Unit	Ambiant temperature 24 hours average				
			°C	35	40	45	50
Busbar trunking installed indoors	k1	%	k1=1	k1=0.97	k1=0.93	k1=0.90	k1=0.86
Busbar trunking installed outside under an aluminium roof	k1	%	See "Busbar trunking installed outside under an aluminium roof" on page 151.				
Busbar trunking installed in a fire duct	k1	%	Please, see your sales office.				

#### Through-wall fire barrier

Tests performed in accordance with the requirements of NF EN 1363-1 and those specific to EN 1366-3.

	Performance criteria	
	Fire integrity	Thermal insulation
Without external fire barrier	120 mn	30 mn
With external fire barrier	120 mn	120 mn

#### Tap-off unit characteristics

##### General characteristics

	Symbol	Unit	
Protection degree	IP		55
Shock resistance	IK		08
Rated insulation voltage	Ui	V	400 or 500 depending on protection device
Rated operating voltage	Ue	V	
Operating frequency	f	Hz	50/60

#### Derating to apply to the KTA5000

##### Installation type

	Utilisation	
	Transport	Distribution
Edgewise installation	0.96	0.9
Flatwise installation	0.85	0.85

A

B

C

D

E

F

G

# Determining the rating

## Providing power distribution using Canalis

### Canalis KTA

A

B

C

D

E

F

G

#### Apart from extreme atmospheres, Canalis can be installed anywhere!

The order described below is only aimed at presenting the different stages for a simple installation.

For a detailed design, it is necessary to use appropriate tools, approved by control bodies, in compliance with local installation standards.

The **Ecodial** software, edited by Schneider Electric, meets this requirement perfectly.

#### Design order:

- 1 – Define run layouts.
- 2 – Identify external influences.
- 3 – Determine the current rating (Ib).
- 4 – Calculate the nominal current (In) taking into account derating coefficients.
- 5 – Choose the busbar trunking rating.
- 6 – Check the rating with respect to allowable voltage drop.
- 7 – Check busbar trunking overloads.
- 8 – Check the rating with respect to short-circuit withstand current.
- 9 – Choose the source and feeder circuit breakers.

### 1 - Canalis busbar trunking layout

The layout of the distribution runs depends on the position of the loads and where the source is located.

Load protection is placed in the tap-off boxes, at the point of use.

A single and same Canalis busbar trunking supplies a group of loads of different ratings.

Schneider Electric has tools you can use to help you choose the architecture best suited to your application:

- the **Idpro software** to simulate the organisation of your electrical networks
- **application orientated technical guides** (car industry, data centers, shopping centres, etc).

### 2 - Identification of external influences



#### Protection degree

Canalis KT busbar trunking is IP55 and IPxxD by construction.

This protection degree protects the busbar trunking against:

- dust
- penetration by a 1 mm diameter wire
- water projections from all directions.

It can be installed in almost all premises; for more details see the "Determining the protection degree" "Degree of protection", page 168.

Wherever the busbar trunking must pass outside the building, an aluminium roof can be supplied; consult your Schneider Electric distributor for information concerning this option.

#### Corrosive atmosphere

The busbar trunking has been qualified for industrial atmospheres.

For sulphurous atmospheres such as sulphur dioxide (SO<sub>2</sub>) and hydrogen sulphide (H<sub>2</sub>S), there is a suitable Canalis KT solution; consult your Schneider Electric distributor for more information on this option.

**Example:** paper mills, water treatment works, etc.

# Determining the rating

## Providing power distribution using Canalis

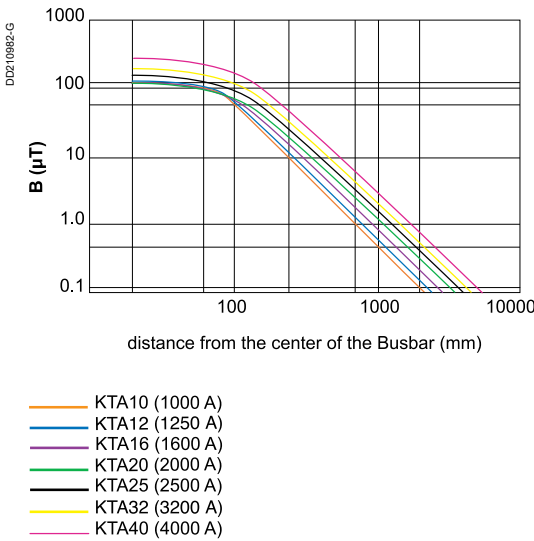

### Radiated electromagnetic fields

According to the WHO (World Health Organisation), exposure to radiated electromagnetic fields above 0.2 micro Tesla can be dangerous causing a risk of cancer over the long term. Some countries have standardised the limit: Sweden = 0.2 µT, at a distance of 1 metre.

All electrical conductors generate a magnetic field, the strength of which is proportional to the distance between them. The Canalis busbar trunking concept (metal casing and conductors near together) helps to considerably reduce radiated electromagnetic fields.

In specific cases where particularly low values are required (computer rooms, hospitals, some offices), it is important to keep in mind the following:

- the induction generated around 3-phase distribution. This is proportional to the current and the distance between the conductors, and inversely proportional to the square of the distance with respect to the busbar trunking and the screening effect of the case
- the induction generated around busbar trunking. This is less than the induction generated around an equivalent cable distribution
- Canalis' steel casing. This attenuates the induction more than an equivalent aluminium casing of the same thickness (screening effect)
- the induction generated around busbar trunking with sandwiched bars. This is particularly low because of the short distance between the bars and the additional attenuation provided by the steel casing.



### 3 - Determining the current rating (Ib)

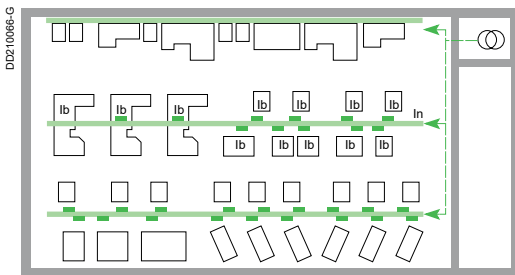

Calculation of the total current (Ib) absorbed by a run is equal to the sum of the currents absorbed by all of the loads.

The loads do not all operate at the same time and, as they are not continuously at full load, a stacking or simultaneity factor Ks has to be taken into account:  
 $I_b = \sum I_b \text{ load} \times K_s$

#### Stacking factor Ks depending on the number of loads according to IEC 61439-1

Application	Number of loads	Ks coefficient
Lighting, heating	-	1
Distribution (mechanic workshop)	2...3	0.9
	4...5	0.8
	6...9	0.7
	10...40	0.6
	40 and over	0.5

**Caution:** for industrial installations, remember to take into account future increases in the number of machines. A 20 % reserve is recommended.

### 4 - Calculating nominal current (In) by applying a derating coefficient

#### Ambient temperature

Canalis busbar trunking is sized to operate at an average ambient temperature of +35°C. Above this value, the busbar trunking must be derated.

**Example:** Canalis KTA1250 A installed inside with an ambient temperature of 45°C:  
 $I_n = 1250 \times 0.93 = 1162 \text{ A}$ .

$$I_n \geq I_b \times k_1 = I_z$$

Where k1 = ambient temperature derating coefficient.

Type of installation	Canalis KT	Ambient temperature 24 hours average (°C)				
		35	40	45	50	55
Busbar trunking installed inside	All	1	0.97	0.93	0.90	0.86
Busbar trunking installed outside under an aluminium roof	All	0.86	0.83	0.80	0.77	0.74
Busbar trunking installed in a fire duct		Please, see your sales office.				

Canalis KTA

5 - Choosing the busbar trunking rating according to the nominal current  $I_n$

Nominal current $I_n$ (A)	Busbar trunking
0 to 800	KTA0800
801 to 1000	KTA1000
1001 to 1250	KTA1250
1251 to 1600	KTA1600
1601 to 2000	KTA2000
2001 to 2500	KTA2500
2501 to 3200	KTA3200
3201 to 4000	KTA4000
4001 to 5000	KTA5000

6 - Checking the rating with respect to allowable voltage drop

The voltage drop between the start and all points of use must not be greater than the values in the table below:

Installation supplied by:	Lighting	Other use
Low voltage public distribution network	3 %	5 %
High voltage distribution network	6 %	8 %

The allowable voltage drop is that which is compatible with correct load operation (refer to manufacturers' guides).

- Read voltage drop in V / 100 m/A for the busbar trunking chosen in accordance with temperature rise.
- Determine the voltage drop for the worst case loads, i.e. those furthest from the source and for the highest current.

If the voltage drop exceeds allowable limits, choose the next rating up. Re-check the voltage drop for the new rating.

Voltage drop, in volts per 100 metres and per amp for 3-phase 50 Hz current with load spread over the run. For loads concentrated at the end of a run (transport), the voltage drops are double those shown in the table below:

Delta U for evenly distributed loads (V/100m/A)									
	KTA08	KTA10	KTA12	KTA16	KTA20	KTA25	KTA32	KTA40	KTA50
Cosine $\varphi = 1$	0.0083	0.0060	0.0049	0.0037	0.0029	0.0024	0.0018	0.0015	0.0012
Cosine $\varphi = 0.9$	0.0081	0.0060	0.0050	0.0038	0.0030	0.0025	0.0019	0.0016	0.00125
Cosine $\varphi = 0.8$	0.0076	0.0056	0.0047	0.0036	0.0029	0.0024	0.0018	0.0015	0.0012
Cosine $\varphi = 0.7$	0.0069	0.0052	0.0043	0.0034	0.0027	0.0022	0.0017	0.0015	0.0011

**Example:** for the KTA1600 A busbar trunking:

$I_b = 1530$  A  
 $I_n = 1600$  A  
 Length  $L = 87$  m  
 Cosine  $\varphi = 0.8$ .

According to the above table, the voltage drop coefficient for 100 metres and per amp is equal to 0.0036 V/100 m/A.

$0.0036 \times 0.87 \times 1530 = 4.79$  V  
 For a voltage = 400 V, in percentages:  
 $4.79 / 400 = 0.0119$  that is to say 1.2 %.



### 7 - Protecting against busbar trunking overloads

To allow for extensions, the busbar trunking is generally protected at its nominal current  $I_{nc}$  (or its allowable current  $I_z$  if the ambient temperature coefficient  $k_1$  is applied).

- Circuit breaker protection:
  - adjust  $I_r$  of the circuit breaker such that:  
 $I_z = I_b \times k_1 \leq I_r \leq I_{nc}$

Circuit breaker protection allows the Canalis busbar trunking to be used at full capacity because the standardised nominal current  $I_n$  of the circuit breaker is  $I_n \leq I_{nc} / K_2$  where  $K_2 = 1$ .

- Protection using gG (gl) fuse:
  - determine the standardised nominal current  $I_n$  of the fuse such that:  $I_n \leq I_{nc} / K_2$  where  $K_2 = 1.1$ .
  - choose the standardised rating  $I_n$  that is equal to or just lower.
 Check the following condition:  $I_n \geq I_b \times k_1 = I_z$ .  
 If this condition is not met, choose the busbar trunking with the next rating up.

**Note:** using gl fuses for protection means reducing the busbar trunking's allowable current.

### 8 - Checking the rating and choice of circuit breaker with respect to short-circuit withstand current

Short-circuit current withstand is shown in the table below.

This value must be greater than the prospective short-circuit current, at all points of the installation.

- Calculate the short-circuit current value at the worst case points.
- Check the chosen rating allows the busbar trunking to cope with this short-circuit current.
- If this is not the case, there are 2 possible solutions:
  - choose a higher rating busbar trunking and re-check
  - provide a peak current limiting protection system upstream of the busbar trunking.

**Warning:** regarding the TNS or TNC earthing system, based on the value of L-PE fault loop impedance and the level of L-PE short-circuit, choose the correct coordination between the protection and the busbar trunking.

Canalis KT is more than sized to cope with short-circuit currents.

Some specific cases require checks to be carried out: transformers in parallel, low rating Canalis installed close to a transformer, etc.

A

B

C

D

E

F

G

# Protection of circuits supplied by several paralleled transformers

Canalis KTA

## 9 - Choosing source and feeder circuit breakers according to the number and rating of the supply transformers

A

B

C

D

E

F

G

The choice of a circuit breaker to protect a circuit depends mainly on the following 2 criteria:

- the nominal current of the source or the loads, which determines the appropriate rating of the device
- the maximum short-circuit current at the point in question, which determines the minimum breaking capacity of the device.

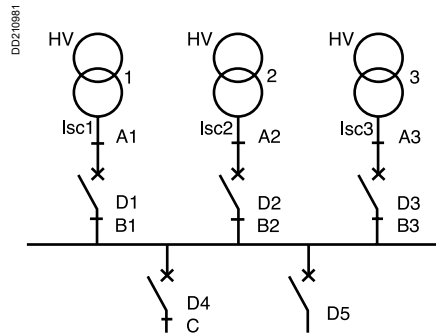

For the case of several parallel transformers<sup>(1)</sup>:

- the source circuit breaker D1 must have a breaking capacity greater than the largest of the 2 following values:
  - either  $I_{sc1}$  (short-circuit at B1)
  - or  $I_{sc2} + I_{sc3}$  (short-circuit at A1)
- the feeder circuit breaker D4 must have a breaking capacity greater than  $I_{sc1} + I_{sc2} + I_{sc3}$ .

The table allows the following to be determined:

- the source circuit breaker, according to the number and rating of the supply transformers (in the case of a single transformer, the table recommends a fixed circuit breaker; in the case of several transformers, the table shows a drawout circuit breaker and a fixed circuit breaker)
- the feeder circuit breaker, according to the sources and the nominal current rating of the feeder (the circuit breakers shown in the table can be replaced by limiter circuit breakers if the cascading technique is to be used with other circuit breakers downstream of the feeder).

(1) To couple several transformers in parallel, the transformers must have the same  $U_{sc}$ , the same transformation ratio, the same coupling and the ratio of the power rating of the 2 transformers must be less than or equal to 2.

### Example:

3 incoming 1250 kVA transformers 20 kV/410 V ( $I_n = 1760$  A).

Feeders: including one 2000 A feeder, one 1600 A feeder and one 1000 A feeder.

What circuit breakers should be fitted at the incomer and for the feeders?

■ Incomer circuit breakers:

either the Drawout Masterpact NW20N1 or the Drawout NS2000N circuit breakers can be chosen. The choice will depend on the options required.

■ Feeder circuit breakers:

the NW20H2 for the 2000 A feeder, the NW16H2 for the 1600 A feeder and the NW10H2 for the 1000 A feeder are to be chosen.

These circuit breakers have the advantage of providing discrimination (full discrimination) with the NW12H1 or NS1250N circuit breakers.

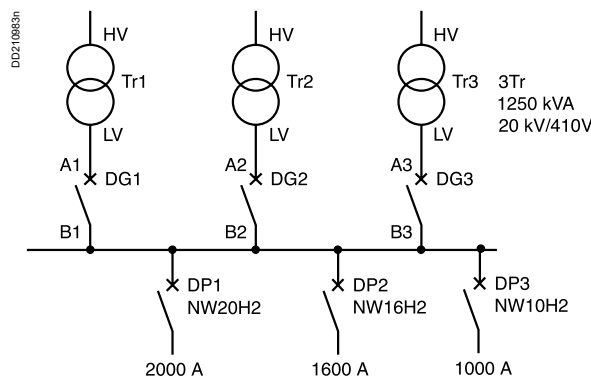

# Protection of circuits supplied by several paralleled transformers

## Calculation assumption:

- the upstream network short-circuit power is not defined
- the transformers are 20 kV / 410 V
- between each transformer and corresponding circuit breaker there is 5 metres of KT busbar trunking
- between a source circuit breaker and a feeder circuit breaker there is 1 metre of bars
- the equipment is installed into a switchboard with an ambient temperature of 40°C.

Transformer				Source min. break. cap. (kA)	Source circuit breaker	Feeder min. break. cap. (kA)	Feeder circuit breaker				
P (kVA)	In (A)	Usc (%)	Isc (kA)				≤ 100 A	160 A	250 A	400 A	630 A
<b>1 transformer</b>											
50	70	4	2	2	NSX100N TM-D / STR22SE	2	NSX100N				
100	141	4	4	4	NSX160N TM-D / STR22SE	4	NSX100N	NSX160N			
160	225	4	6	6	NSX250N TM-D / STR22SE	6	NSX100N	NSX160N	NSX250N		
250	352	4	9	9	NSX400N STR23SE / 53UE	9	NSX100N	NSX160N	NSX250N	NSX400N	
400	563	4	14	14	NSX630N STR23SE / 53UE	14	NSX100N	NSX160N	NSX250N	NSX400N	NSX630N
630	887	4	22	22	NS1000N NT10H1 NW10N1 Micrologic	22	NSX100N	NSX160N	NSX250N	NSX400N	NSX630N
800	1127	6	19	19	NS1250N NT12H1 NW12N1 Micrologic	19	NSX100N	NSX160N	NSX250N	NSX400N	NSX630N
1000	1408	6	23	23	NS1600N NT16H1 NW16N1 Micrologic	23	NSX100N	NSX160N	NSX250N	NSX400N	NSX630N
1250	1760	6	29	29	NW20N1 Micrologic	29	NSX100H	NSX160N	NSX250N	NSX400N	NSX630N
1600	2253	6	38	38	NW25H1 Micrologic	38	NSX100H	NSX160H	NSX250H	NSX400N	NSX630N
2000	2816	6	47	47	NW32H1 Micrologic	47	NSX100H	NSX160H	NSX250H	NSX400H	NSX630H
2500	3521	6	59	59	NW40H1 Micrologic	59	NSX100H	NSX160H	NSX250H	NSX400H	NSX630H
<b>2 transformers</b>											
50	70	4	2	2	NSX100N TM-D / STR22SE	4	NSX100N	NSX160N			
100	141	4	4	4	NSX160N TM-D / STR22SE	7	NSX100N	NSX160N	NSX250N		
160	225	4	6	6	NSX250N TM-D / STR22SE	11	NSX100N	NSX160N	NSX250N	NSX400N	
250	352	4	9	9	NSX400N STR23SE / 53UE	18	NSX100N	NSX160N	NSX250N	NSX400N	NSX630N
400	563	4	14	14	NSX630N STR23SE / 53UE	28	NSX100H	NSX160N	NSX250N	NSX400N	NSX630N
630	887	4	22	22	NS1000N NT10H1 NW10N1 Micrologic	44	NSX100H	NSX160H	NSX250H	NSX400N	NSX630N
800	1127	6	19	19	NS1250N NT12H1 NW12N1 Micrologic	38	NSX100H	NSX160H	NSX250H	NSX400N	NSX630N
1000	1408	6	23	23	NS1600N NT16H1 NW16N1 Micrologic	47	NSX100H	NSX160H	NSX250H	NSX400H	NSX630H
1250	1760	6	29	29	NW20N1 Micrologic	59	NSX100H	NSX160H	NSX250H	NSX400H	NSX630H
1600	2253	6	38	38	NW25H1 Micrologic	75	NSX100L	NSX160L	NSX250L	NSX400L	NSX630L
2000	2816	6	47	47	NW32H1 Micrologic	94	NSX100L	NSX160L	NSX250L	NSX400L	NSX630L
2500	3521	6	59	59	NW40H1 Micrologic	117	NSX100L	NSX160L	NSX250L	NSX400L	NSX630L
<b>3 transformers</b>											
50	70	4	2	4	NSX100N TM-D / STR22SE	5	NSX100N	NSX160N	NSX250N		
100	141	4	4	7	NSX160N TM-D / STR22SE	11	NSX100N	NSX160N	NSX250N	NSX400N	
160	225	4	6	11	NSX250N TM-D / STR22SE	17	NSX100N	NSX160N	NSX250N	NSX400N	NSX630N
250	352	4	9	18	NSX400N STR23SE / 53UE	26	NSX100H	NSX160N	NSX250N	NSX400N	NSX630N
400	563	4	14	28	NSX630N STR23SE / 53UE	42	NSX100H	NSX160H	NSX250H	NSX400N	NSX630N
630	887	4	22	44	NS1000N NT10L1 NW10H1 Micrologic	67	NSX100H	NSX160H	NSX250H	NSX400H	NSX630H
800	1127	6	19	38	NS1250N NT12H1 NW12N1 Micrologic	56	NSX100H	NSX160H	NSX250H	NSX400H	NSX630H
1000	1408	6	23	47	NS1600N NW16H1 Micrologic	70	NSX100H	NSX160H	NSX250H	NSX400H	NSX630H
1250	1760	6	29	59	NS2000N NW20N1 Micrologic	88	NSX100L	NSX160L	NSX250L	NSX400L	NSX630L
1600	2253	6	38	75	NS2500N NW25H2 Micrologic	113	NSX100L	NSX160L	NSX250L	NSX400L	NSX630L
2000	2816	6	47	94	NS3200N NW32H2 Micrologic	141	NSX100L	NSX160L	NSX250L	NSX400L	NSX630L

Usc values as defined in HD 428.

# Coordination

## Protection of busbar trunking against overloads

### Canalis KTA

#### Introduction

A

B

C

D

E

F

G

#### Adequacy between circuit breaker ratings and busbar trunking

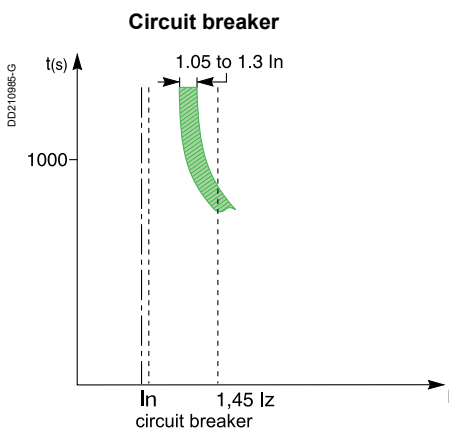
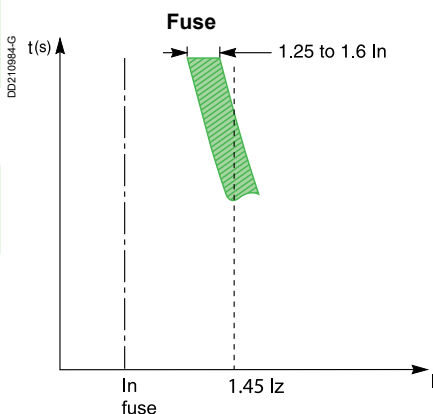

System performance is guaranteed by coordination between the Schneider Electric circuit breaker protection and the distribution spread over the Canalis busbar trunking.

Fully coordinated distributed electrical distribution perfectly meets the requirements of safety, service continuity, system changes and simplicity.

In the following pages, we will explain the advantages of the Schneider Electric system and Schneider Electric circuit breaker protection, as well as the selection guide tables for coordination between the Schneider Electric circuit breakers and the Canalis busbar trunking.

#### The use of Schneider Electric circuit breakers provides:

- protection against overloads and short-circuits;
- coordination between the protective devices and the Canalis busbar trunking:
  - full discrimination from 1 to 6300 A between all the circuit breakers of the Schneider Electric ranges
  - cascading:
    - reinforcement of the small and medium power busbar trunking short-circuit protective devices. This enables all short-circuit levels to be covered
    - protection of tap-offs using standard circuit breakers: this is achieved whatever the position of the tap-off unit on the Canalis busbar trunking
- the use of standard circuit breakers makes for simpler design whilst respecting a high level of dependability
- fault location is quick and easy
- resetting is easy once the fault has been cleared by the site operator.

In order to take into consideration thermal overload protection of busbar trunking, the different technologies of the protection switchgear and the maximum overload operating currents must be considered.

By design, the thermal adjustment of a circuit breaker is more accurate.

- $I_z = I_b \times k_1 \times k_2$
- $I_b$ : current rating
- $I_z$ : allowable busbar trunking current
- $k_1$ : temperature derating coefficient
- $k_2$ : derating coefficient linked to the type of switchgear:
  - fuse  $k_2 = 1.1$
  - circuit breaker  $k_2 = 1$ .
- $I_z = I_b \times k_1$ .
- $I_n = I$  standardised fuse or circuit breaker.

#### Example:

For a current rating  $I_b = 1900$  A in an ambient temperature of  $35^\circ\text{C}$ :

- fuse protection:
  - $I_z = I_b \times k_1 \times k_2 = 1900 \times 1 \times 1.1 = 2090$  A
  - The correct choice of busbar trunking is the KTA25 ( $I_z = 2500$  A)

- circuit breaker protection:
  - $I_z = I_b \times k_1 \times k_2 = 1900 \times 1 \times 1 = 1900$  A
  - The correct choice of busbar trunking is the KTA20 ( $I_z = 2000$  A),

A difference of 20 % in the measurement of operating currents results in an over-rating of the busbar trunking of 10 % if it is protected by fuses.

#### Explanations

- Calibration of thermal asymptotes:
  - the distribution fuse is calibrated to operate for overloads of between 1.25 and 1.6 times its nominal current ( $I_n$  fuse)
  - the circuit breaker is calibrated to operate for overloads of between 1.05 and 1.3 times (1.2 for circuit breakers with electronic protection) its setting current ( $I_r$  which is a function of circuit breaker  $I_n$ ).
- Maximum operating current:
  - the maximum limit for this current is set by installation standards (IEC 364, NFC 15-100, etc) at 1.45 times the allowable current of the busbar trunking.

# Protection of busbar trunking against overloads

## Thermal setting accuracy

- A fuse is for a fixed rating, a change in the current to be protected requires a change of fuse.  
The spacing between 2 fuse ratings is around 25 %.  
The typical ratings are conform to the numbers of the "Renard" series.

**Example:** 40 - 50 - 63 - 80 - 100 - 125 - 160 - 200 - etc.

- The circuit breaker provides the possibility of fine adjustment:

- 5 % for circuit breakers fitted with standard thermal-magnetic trip units
- 3 % for circuit breakers fitted with electronic trip units.

A circuit breaker with a nominal rating of 100 A can be easily set to the following values:

$I_r = 100 \text{ A}, 95 \text{ A}, 90 \text{ A}, 85 \text{ A}, 80 \text{ A}.$

**Example:**

A circuit breaker with a nominal rating of 1600 A set at 1440 A would be used to protect a KTA1600 ( $I_{nc} = 1440 \text{ A}$ ) busbar trunking used in an ambient temperature of 50°C ( $k_1 = 0.9$ ).

## Setting range of circuit breakers fitted with electronic trip units

Circuit breakers fitted with electronic trip units have the following setting ranges:

- thermal protection  $I_r$  adjustable from 0.4  $I_n$  to  $I_n$
- short-circuit protection adjustable from 2  $I_r$  to 10  $I_r$

**Example:**

A 250 A circuit breaker (NS250N fitted with an STR22SE) can easily have the following settings:

- thermal protection from 100 to 250 A
- short-circuit protection from 200 to 2500 A.

### Advantages

This provides great flexibility for:

- modifications (flexibility), extensions (installation changes): the protective devices easily adapt to the load to be protected and to the earthing system (protection of personnel and equipment)
- maintenance, the use of this type of device considerably reduces the stocks of maintenance components.

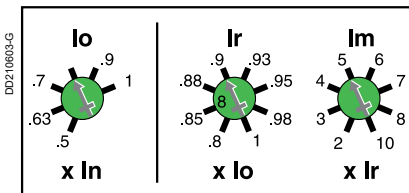

Example of setting possibilities.



# Coordination

## Protection against short-circuits

### Canalis KTA

#### Busbar trunking characteristics

A

B

C

#### Circuit breaker characteristics

D

#### Circuit breaker / busbar trunking system characteristics

E

F

G

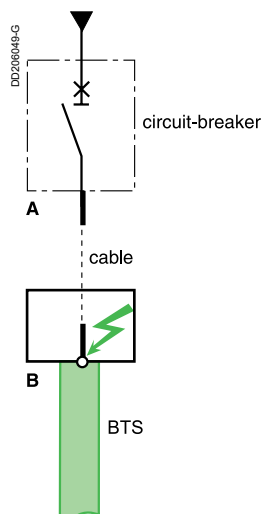
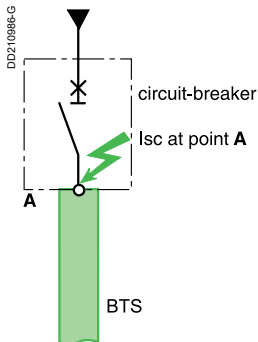

The busbar trunking must meet all of the rules detailed in IEC 61439-1 and IEC 61439-6.

The sizing of busbar trunking for short-circuits is determined by the following characteristics:

- the allowable rated peak current I<sub>pk</sub> (kA).

This characteristic represents the busbar trunking's instantaneous electrodynamic withstand limits. The peak current value is often the most restrictive instantaneous characteristic for the protective device

- the maximum short-time withstand rms current I<sub>cw</sub> (kArms/s).

This characteristic represents the allowable temperature rise limit of the conductors during a given time period (0.1 to 1s)

- the thermal stress in A<sup>2</sup>s.

This characteristic represents the instantaneous thermal stress withstand of the busbar trunking. In general, if the short-circuit generates fault conditions compatible with the first two characteristics, this constraint is "automatically satisfied".

The circuit breaker must satisfy the requirements of product construction standards (IEC 60947-2, etc) and installation standards (IEC 60364 or those in force in the country concerned), i.e. have a breaking capacity I<sub>cu</sub><sup>(1)</sup> greater than the prospective short-circuit current I<sub>sc</sub> at the point where it is installed.

(1) Installation standard IEC 60364 and construction standards specify the breaking capacity of a circuit breaker as being:

- the ultimate breaking capacity, I<sub>cu</sub>, if it is not coordinated with an upstream protective device,
- the reinforced breaking capacity (cascading) if there is coordination with the upstream protective device.

When the busbar trunking is directly protected, the circuit breaker must be chosen as follows:

- I<sub>cu</sub> of the circuit breaker ≥ prospective I<sub>sc</sub> at point A
- I<sub>pk</sub> of the busbar trunking ≥ prospective asymmetrical or limited I<sub>sc</sub> at point A
- busbar trunking thermal withstand I<sub>cw</sub> ≥ thermal stress through the busbar trunking.

When the busbar trunking is protected downstream of a cable, the circuit breaker must be chosen as follows:

- I<sub>cu</sub> of the circuit breaker ≥ prospective I<sub>sc</sub> at point A
- I<sub>pk</sub> of the busbar trunking ≥ prospective asymmetrical or limited I<sub>sc</sub> at point B
- busbar trunking thermal withstand I<sub>cw</sub> ≥ thermal stress through the busbar trunking.

# Circuit breaker/busbar trunking coordination

## Non-limiting or time-delayed circuit breaker

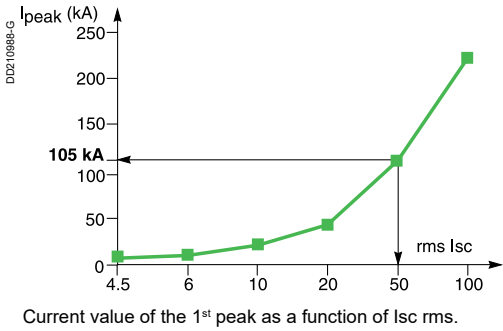

This is applicable for non-limiting circuit breakers (instantaneous or time-delayed) and time-delayed limiting circuit breakers. These are mainly air circuit breakers ( $\geq 800$  A).

This type of circuit breaker is used for time discrimination and is therefore often associated with KT type busbar trunking.

It must be checked that the busbar trunking can handle the peak fault current to which it may be subjected and the thermal withstand during any time delay. The allowable peak current ( $I_{peak}$ ) of the busbar trunking must be greater than the peak current value of the prospective asymmetrical short-circuit current ( $I_{sc\ asym}$ ) at A.

The asymmetrical short-circuit current value is obtained by multiplying the symmetrical short-circuit current value ( $I_{sc}$ ) by a standardised asymmetrical coefficient ( $k$ ).

It is the first value of the 1<sup>st</sup> transient asymmetrical peak of the short-circuit which is taken into account.

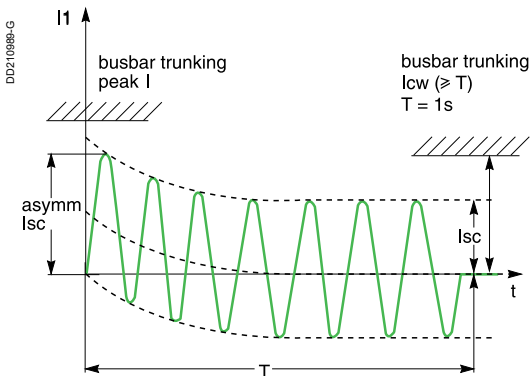

Transient and established conditions of a short duration short-circuit.

### Standardised table for calculating asymmetrical short-circuit values

I <sub>sc</sub> : prospective symmetrical short-circuit value	Asymmetrical coefficient
kA (rms value)	k
$4,5 \leq I \leq 6$	1.5
$6 < I \leq 10$	1.7
$10 < I \leq 20$	2.0
$20 < I \leq 50$	2.1
$50 < I$	2.2

### Example:

For a circuit with a prospective short-circuit current of 50 kA rms, the 1<sup>st</sup> peak reaches 105 kA (50 kA x 2.1), see figure opposite.

The short-time withstand value ( $I_{cw}$ ) of the busbar trunking must be greater than the current flowing through the installation during the duration of the short-circuit ( $I_{sc}$ ) (duration T - total breaking time - including any time delay).

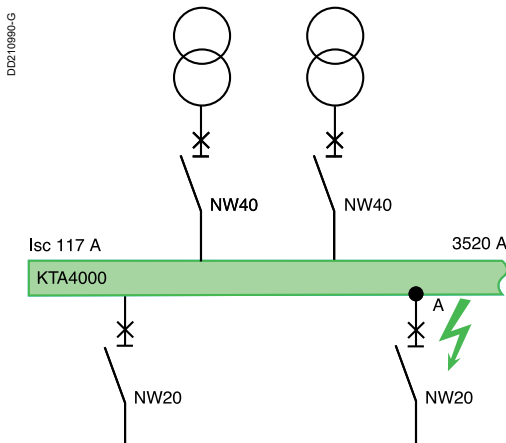

At point A, the prospective short-circuit current is 117 kArms.

To meet this constraint, a reinforced KTA4000 is needed because:  $I_{cw\ KTA4000} > I_{sc\ prospective\ at\ point\ A}$ .

The  $I_{cw}$  or  $I_{pk}$  values of standard or reinforced KTA trunking allow the easy construction of circuits with time discrimination, even with high short-circuit values.



# Circuit breaker/busbar trunking coordination

## Limiter circuit breaker

### Canalis KTA

This is mainly applicable to the protection of busbar trunking using moulded case circuit breakers ( $\leq 1600$  A). This type of circuit breaker is used for energy discrimination and is therefore often associated with Canalis KTA.

Here, it has to be checked that the busbar trunking can cope with the peak current ( $I_{pk}$ ) limited by the protective device and the corresponding thermal stress ( $A^2s$ ):

- the peak current ( $I_{peak}$ ), once limited by the circuit breaker, must be less than the allowable peak current value of the busbar trunking
- the thermal stress, once limited by the circuit breaker, must be less than the allowable thermal stress of the busbar trunking.

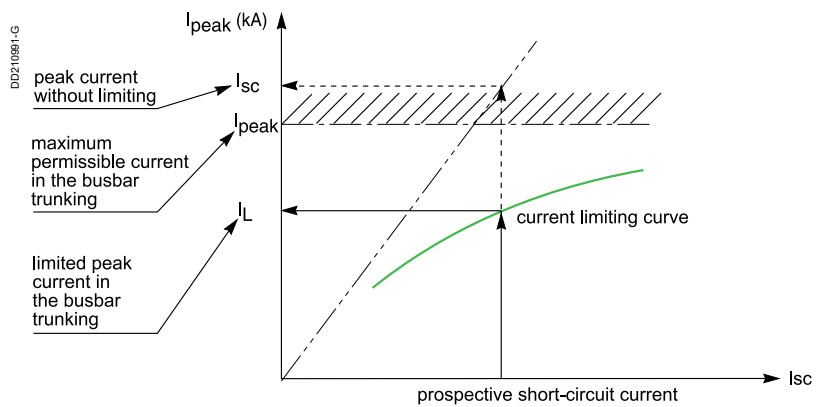

Checking peak I withstand of the busbar trunking.

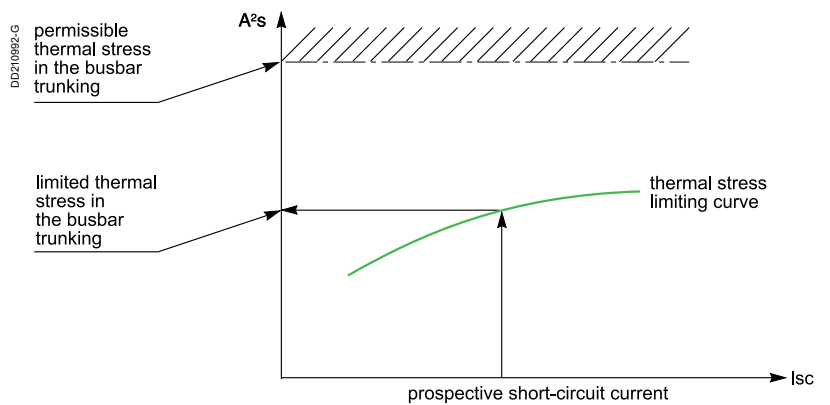

Checking  $A^2s$  withstand of the busbar trunking.



# Protecting busbar trunking with a Compact NS circuit breaker

## Limiting capacity

Compact NS circuit breakers are high current limiting circuit breakers. The limiting capacity of a circuit breaker is its capacity to only allow a limited current (IL) to flow in the event of a short-circuit. This limited current being less than the prospective asymmetrical peak short-circuit current (Isc). This greatly reduces the electrodynamic and thermal constraints on the installation to be protected.

## Applying limiting capacity to busbar trunking protection

Even if this combination is less frequent than for KS busbar trunking, some KT ratings can benefit from the association with a limiter circuit breaker.

### High power installation

If the circuit breaker's limiting capacity is not taken into account:

- the prospective short-circuit current value (Isc) at point A would be 121 kA
- KTA1600 would be the appropriate choice of busbar trunking.

If the limiting capacity of the Compact NS1000L is taken into account, the limited Ipk is 50 kA < 110 kA of the KTA1000 busbar trunking.

Because of the high limiting capacity of the Compact NS1000L, a KTA1000 busbar trunking can be installed into a prospective short-circuit current at point A of 150 kA rms or 300 kA.

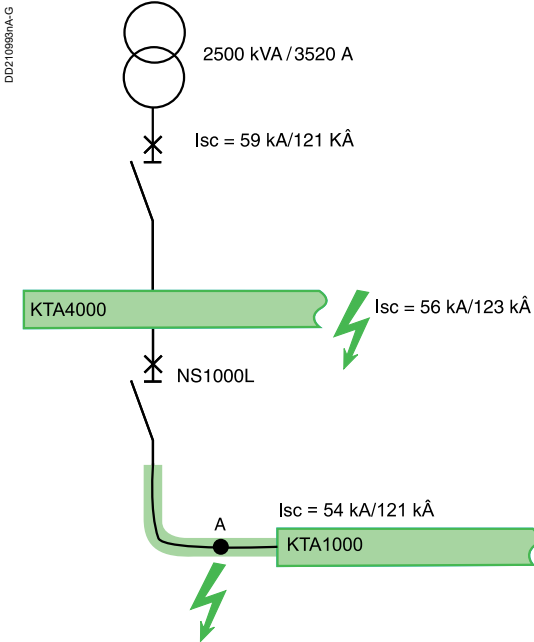

### Canalis KTA

The selection guide below will, according to the prospective short-circuit current of the installation, allow you to determine the type of circuit breaker needed to fully protect the busbar trunking.

**Example:** for an installation with a prospective I<sub>sc</sub> of 150 kA, the circuit breaker needed to protect a KTA1250 A busbar trunking is a **NS100L** or **NT10L1** (the rating depends on the circuit's nominal current).

#### For a voltage of 380/415 V

Type of Canalis busbar trunking		KTA0800					
Isc max kArms		30 kA	50 kA	65 kA	85 kA	100 kA	150 kA
Type of circuit breaker	Compact NSX	NSX630F (≥ 36 kA)	NSX630N/H/S/L	NSX630H/S/L	NSX630S/L	NSX630S/L	NSX630L
	Compact NS	NS630bN <b>NS800N</b> NS1000N				NS630bL <b>NS800L</b> NS1000L	NS630bLB <b>NS800LB</b>
	Masterpact MTZ1	MTZ1 06 H1/H2/H3/L1 <b>MTZ1 08 H1/H2/H3/L1</b> MTZ1 10 H1/H2/H3/L1	MTZ1 06 L1 <b>MTZ1 08 L1</b> MTZ1 10 L1				
	Masterpact MTZ2	<b>MTZ2 08 N1/H1/H2/L1</b> MTZ2 10 N1/H1/H2/L1					
	Masterpact NT	NT06 H1 <b>NT08 H1</b> NT10 H1				NT06 L1 <b>NT08 L1</b> NT10 L1	
	Masterpact NW	<b>NW08H1</b> NW10H1					
Type of Canalis busbar trunking		KTA0800 Reinforced short-circuit level					
Isc max kArms		30 kA	50 kA	65 kA	85 kA	100 kA	150 kA
Type of circuit breaker	Compact NSX	NSX630F (≥ 36 kA)	NSX630N/H/S/L	NSX630H/S/L	NSX630S/L	NSX630S/L	NSX630L
	Compact NS	NS630bN <b>NS800N</b> NS1000N				NS630bL <b>NS800L</b> NS1000L	NS630bLB <b>NS800LB</b>
	Masterpact MTZ1	MTZ1 06 H1/H2/H3/L1 <b>MTZ1 08 H1/H2/H3/L1</b> MTZ1 10 H1/H2/H3/L1	MTZ1 06 L1 <b>MTZ1 08 L1</b> MTZ1 10 L1				
	Masterpact MTZ2	<b>MTZ2 08 N1/H1/H2/L1</b> MTZ2 10 N1/H1/H2/L1					
	Masterpact NT	NT06 H1 <b>NT08 H1</b> NT10 H1				NT06 L1 <b>NT08 L1</b> NT10 L1	
	Masterpact NW	<b>NW08H1</b> NW10H1					
Type of Canalis busbar trunking		KTA1000					
Isc max kArms		42 kA	50 kA	65 kA	85 kA	100 kA	150 kA
Type of circuit breaker	Compact NS		NS800N <b>NS1000N</b> NS1250N				NS800L <b>NS1000L</b>
	Masterpact MTZ1	MTZ1 08 H1/H2/H3/L1 <b>MTZ1 10 H1/H2/H3/L1</b> MTZ1 12 H1/H2/H3	MTZ1 08 H2/H3/L1 <b>MTZ1 10 H2/H3/L1</b> MTZ1 12 H2/H3	MTZ1 08 L1 <b>MTZ1 10 L1</b>			
	Masterpact MTZ2	MTZ2 08 N1/H1/H2/L1 <b>MTZ2 10 N1/H1/H2/L1</b> MTZ2 12 N1/H1/H2/L1	MTZ2 08 H1/H2/L1 <b>MTZ2 10 H1/H2/L1</b> MTZ2 12 H1/H2/L1				
	Masterpact NT	NT08H1 <b>NT10H1</b> NT12H1	NT08H2 <b>NT10H2</b> NT12H2				NT08L1 <b>NT10L1</b>
	Masterpact NW	NW08N1 <b>NW10N1</b> NW12N1	NW08H1 <b>NW10H1</b> NW12H1				
Type of Canalis busbar trunking		KTA1000 Reinforced short-circuit level					
Isc max kArms		42 kA	50 kA	65 kA	85 kA	100 kA	150 kA
Type of circuit breaker	Compact NS		NS800N <b>NS1000N</b> NS1250N	NS800H <b>NS1000H</b> NS1250H			NS800L <b>NS1000L</b>
	Masterpact MTZ1	MTZ1 08 H1/H2/H3/L1 <b>MTZ1 10 H1/H2/H3/L1</b> MTZ1 12 H1/H2/H3	MTZ1 08 H2/H3/L1 <b>MTZ1 10 H2/H3/L1</b> MTZ1 12 H2/H3	MTZ1 08 H3/L1 <b>MTZ1 10 H3/L1</b> MTZ1 12 H3	MTZ1 08 L1 <b>MTZ1 10 L1</b>		
	Masterpact MTZ2	MTZ2 08 N1/H1/H2/L1 <b>MTZ2 10 N1/H1/H2/L1</b> MTZ2 12 N1/H1/H2/L1	MTZ2 08 H1/H2/L1 <b>MTZ2 10 H1/H2/L1</b> MTZ2 12 H1/H2/L1		MTZ2 08 L1 <b>MTZ2 10 L1</b> MTZ2 12 L1		
	Masterpact NT	NT08H1 <b>NT10H1</b> NT12H1	NT08H2 <b>NT10H2</b> NT12H2				NT08L1 <b>NT10L1</b>
	Masterpact NW	NW08N1 <b>NW10N1</b> NW12N1		NW08H1 <b>NW10H1</b> NW12H1	NW08L1 <b>NW10L1</b> NW12L1		

Type of Canalis busbar trunking		KTA1250					
Isc max kArms		42 kA	50 kA	65 kA	85 kA	100 kA	150 kA
Type of circuit breaker	Compact NS		NS1000N NS1250N NS1600N				NS1000L
	Masterpact MTZ1	MTZ1 10 H1/H2/H3/L1 MTZ1 12 H1/H2/H3 MTZ1 16 H1/H2/H3	MTZ1 10 H2/H3/L1 MTZ1 12 H2/H3 MTZ1 16 H2/H3	MTZ1 10 L1			
	Masterpact MTZ2	MTZ2 10 N1/H1/H2/L1 MTZ2 12 N1/H1/H2/L1 MTZ2 16 N1/H1/H2/L1	MTZ2 10 H1/H2/L1 MTZ2 12 H1/H2/L1 MTZ2 16 H1/H2/L1				
	Masterpact NT	NT10H1 NT12H1 NT16H1	NT10H2 NT12H2 NT16H2				NT10L1
	Masterpact NW	NW10N1 NW12N1 NW16N1	NW10H1 NW12H1 NW16H1				
Type of Canalis busbar trunking		KTA1250 Reinforced short-circuit level					
Isc max kArms		42 kA	50 kA	65 kA	85 kA	100 kA	150 kA
Type of circuit breaker	Compact NS		NS1000N NS1250N NS1600N	NS1000H NS1250H NS1600H			NS1000L
	Masterpact MTZ1	MTZ1 10 H1/H2/H3/L1 MTZ1 12 H1/H2/H3 MTZ1 16 H1/H2/H3	MTZ1 10 H2/H3/L1 MTZ1 12 H2/H3 MTZ1 16 H2/H3	MTZ1 10 H3/L1 MTZ1 12 H3 MTZ1 16 H3	MTZ1 10 L1		
	Masterpact MTZ2	MTZ2 10 N1/H1/H2/L1 MTZ2 12 N1/H1/H2/L1 MTZ2 16 N1/H1/H2/L1	MTZ2 10 H1/H2/L1 MTZ2 12 H1/H2/L1 MTZ2 16 H1/H2/L1		MTZ2 10 L1 MTZ2 12 L1 MTZ2 16 L1		
	Masterpact NT	NT10H1 NT12H1 NT16H1	NT10H2 NT12H2 NT16H2				NT10L1
	Masterpact NW	NW10N1 NW12N1 NW16N1		NW10H1 NW12H1 NW16H1	NW10L1 NW12L1 NW16L1		
Type of Canalis busbar trunking		KTA1600					
Isc max kArms		42 kA	50 kA	65 kA	85 kA	100 kA	150 kA
Type of circuit breaker	Compact NS		NS1250N NS1600N	NS1250H NS1600H NS1600bN NS2000N			
	Masterpact MTZ1	MTZ1 12 H1/H2/H3 MTZ1 16 H1/H2/H3	MTZ1 12 H2/H3 MTZ1 16 H2/H3	MTZ1 12 H3 MTZ1 16 H3			
	Masterpact MTZ2	MTZ2 12 N1/H1/H2/L1 MTZ2 16 N1/H1/H2/L1 MTZ2 20 N1/H1/H2/H3/L1	MTZ2 12 H1/H2/L1 MTZ2 16 H1/H2/L1 MTZ2 20 H1/H2/H3/L1		MTZ2 12 L1 MTZ2 16 L1 MTZ2 20 L1		
	Masterpact NT	NT12H1 NT16H1	NT12H2 NT16H2				
	Masterpact NW	NW12N1 NW16N1 NW20H1		NW12H1 NW16H1 NW20H1		NW12L1 NW16L1 NW20L1	
Type of Canalis busbar trunking		KTA1600 PER Reinforced short-circuit level					
Isc max kArms		42 kA	50 kA	65 kA	85 kA	100 kA	150 kA
Type of circuit breaker	Compact NS		NS1250N	NS1250H NS1600H NS1600bN NS2000N	NS1600bH NS2000H		
	Masterpact MTZ1	MTZ1 12 H1/H2/H3 MTZ1 16 H1/H2/H3	MTZ1 12 H2/H3 MTZ1 16 H2/H3	MTZ1 12 H3 MTZ1 16 H3			
	Masterpact MTZ2	MTZ2 12 N1/H1/H2/L1 MTZ2 16 N1/H1/H2/L1 MTZ2 20 N1/H1/H2/H3/L1	MTZ2 12 H1/H2/L1 MTZ2 16 H1/H2/L1 MTZ2 20 H1/H2/H3/L1		MTZ2 12 H2/L1 MTZ2 16 H2/L1 MTZ2 20 H2/H3/L1	MTZ2 12 L1 MTZ2 16 L1 MTZ2 20 L1	
	Masterpact NT	NT12H1 NT16H1	NT12H2 NT16H2				
	Masterpact NW	NW12N1 NW16N1		NW12H1 NW16H1 NW20H1	NW12H2 NW16H2 NW20H2		NW12L1 NW16L1 NW20L1
Type of Canalis busbar trunking		KTA2000					
Isc max kArms		42 kA	50 kA	65 kA	85 kA	100 kA	150 kA
Type of circuit breaker	Compact NS			NS1600bN NS2000N			
	Masterpact MTZ1	MTZ1 16 H1/H2/H3	MTZ1 16 H2/H3	MTZ1 16 H3			
	Masterpact MTZ2	MTZ2 16 N1/H1/H2/L1 MTZ2 20 N1/H1/H2/H3/L1 MTZ2 25 H1/H2/H3	MTZ2 16 H1/H2/L1 MTZ2 20 H1/H2/H3/L1		MTZ2 16 L1 MTZ2 20 L1		
	Masterpact NT	NT16H1	NT16H2				
Masterpact NW	NW16N1 NW20H1 NW25H1		NW16H1 NW20H1 NW25H1		NW 16 L1 NW20L1		



### Canalis KTA

Type of Canalis busbar trunking		KTA2000 Reinforced short-circuit level					
Isc max kArms		42 kA	50 kA	65 kA	85 kA	100 kA	150 kA
Type of circuit breaker	Compact NS			NS1600bN <b>NS2000N</b>	NS1600bH <b>NS2000H</b>		
	Masterpact MTZ1	MTZ1 16 H1/H2/H3	MTZ1 16 H2/H3	MTZ1 16 H3			
	Masterpact MTZ2	MTZ2 16 N1/H1/H2/L1 <b>MTZ2 20 N1/H1/H2/H3/L1</b>	MTZ2 16 H1/H2/L1 <b>MTZ2 20 H1/H2/H3/L1</b>		MTZ2 16 H2/L1 <b>MTZ2 20 H2/H3/L1</b>		MTZ2 16 L1 <b>MTZ2 20 L1</b>
	Masterpact NT	NT16H1	NT16H2				
Masterpact NW	NW16N1 <b>NW20H1</b> NW25H1			NW16H1 <b>NW20H1</b> NW25H1		NW16H2 <b>NW20H2</b> NW25H2	NW16L1 <b>NW20L1</b>
Type of Canalis busbar trunking		KTA2500					
Isc max kArms		42 kA	50 kA	65 kA	80 kA	100 kA	150 kA
Type of circuit breaker	Masterpact MTZ2	MTZ2 20 H1/H2/H3/L1 <b>MTZ2 25 H1/H2/H3</b>			MTZ2 20 H2/H3/L1 <b>MTZ2 25 H2/H3</b>	MTZ2 20 L1	MTZ2 20 L1
	Masterpact NW	MTZ2 32 H1/H2/H3			NW20H1 <b>NW25H1</b> NW32H1	NW20H2 <b>NW25H2</b> NW32H2	NW20L1 <b>NW25L1</b> NW32L1
Type of Canalis busbar trunking		KTA2500 Reinforced short-circuit level					
Isc max kArms		42 kA	50 kA	65 kA	80 kA	100 kA	110 kA
Type of circuit breaker	Masterpact MTZ2	MTZ2 20 H1/H2/H3/L1 <b>MTZ2 25 H1/H2/H3</b>			MTZ2 20 H2/H3/L1 <b>MTZ2 25 H2/H3</b>	MTZ2 20 L1	MTZ2 20 H3/L1 <sup>(1)</sup> <b>MTZ2 25 H3</b> MTZ2 32 H3
	Masterpact NW	MTZ2 32 H1/H2/H3			NW20H1 <b>NW25H1</b> NW32H1	NW20H2 <b>NW25H2</b> NW32H2	NW20L1 (150 kA) <b>NW25H3</b> NW32H3
Type of Canalis busbar trunking		KTA3200					
Isc max kArms		42 kA	50 kA	65 kA	85 kA	100 kA	110 kA
Type of circuit breaker	Masterpact MTZ2	MTZ2 25 H1/H2/H3 <b>MTZ2 32 H1/H2/H3</b>			MTZ2 25 H2/H3 <b>MTZ2 32 H2/H3</b>		
	Masterpact MTZ3	MTZ3 40 H1/H2/H3			MTZ2 40 H2/H3		
	Masterpact NW	MTZ3 40 H1/H2			NW25H1 <b>NW32H1</b> NW40H1	NW25H2 <b>NW32H2</b> NW40H2 NW40bH1	
Type of Canalis busbar trunking		KTA3200 Reinforced short-circuit level					
Isc max kArms		42 kA	50 kA	65 kA	85 kA	100 kA	110 kA
Type of circuit breaker	Masterpact MTZ2	MTZ2 25 H1/H2/H3 <b>MTZ2 32 H1/H2/H3</b>			MTZ2 25 H2/H3 <b>MTZ2 32 H2/H3</b>		MTZ2 25 H3 <b>MTZ2 32 H3</b> MTZ2 40 H3
	Masterpact MTZ3	MTZ3 40 H1/H2/H3			MTZ2 40 H2/H3		MTZ2 40 H3
	Masterpact NW	MTZ3 40 H1/H2			NW25H1 <b>NW32H1</b> NW40H1	NW25H2 <b>NW32H2</b> NW40H2 NW40bH1	NW32H3 NW40H3 NW40bH2
Type of Canalis busbar trunking		KTA4000					
Isc max kArms		42 kA	50 kA	65 kA	90 kA	100 kA	110 kA
Type of circuit breaker	Masterpact MTZ2	MTZ2 32 H1/H2/H3 <b>MTZ2 40 H1/H2/H3</b>			MTZ2 32 H2/H3 <b>MTZ2 40 H2/H3</b>		
	Masterpact MTZ3	MTZ3 40 H1/H2/H3					
	Masterpact NW	MTZ3 50 H1/H2			NW32H1 <b>NW40H1</b> NW40bH1 NW50H1	NW32H2 <b>NW40H2</b> NW40bH1 NW50H1	
Type of Canalis busbar trunking		KTA4000 Reinforced short-circuit level					
Isc max kArms		42 kA	50 kA	65 kA	90 kA	100 kA	120 kA
Type of circuit breaker	Masterpact MTZ2	MTZ2 32 H1/H2/H3 <b>MTZ2 40 H1/H2/H3</b>			MTZ2 32 H2/H3 <b>MTZ2 40 H2/H3</b>		MTZ2 32 H3 <b>MTZ2 40 H3</b>
	Masterpact MTZ3	MTZ3 40 H1/H2/H3					MTZ3 40 H2 MTZ3 50 H2
	Masterpact NW	MTZ3 50 H1/H2			NW32H1 <b>NW40H1</b> NW40bH1 NW50H1	NW32H2 <b>NW40H2</b> NW40bH1 NW50H1	NW32H3 <b>NW40H3</b> NW40bH2 NW50H2
Type of Canalis busbar trunking		KTA5000 / KTA 5000 Reinforced short-circuit level					
Isc max kArms		42 kA	50 kA	65 kA	90 kA	100 kA	120 kA
Type of circuit breaker	Masterpact MTZ2		MTZ2 32 H1/H2/H3 MTZ2 40 H1/H2/H3		MTZ2 32 H2/H3 MTZ2 40 H2/H3		MTZ2 32 H3 MTZ2 40 H3
	Masterpact MTZ3		MTZ3 40 H1/H2 MTZ3 50 H1/H2				MTZ3 40 H2 MTZ3 50 H2

(1) L1 up to 150 kA.

For a voltage of 660 / 690 V

Type of Canalis busbar trunking		KTA1000						
Isc max kArms		25 kA	30 kA	42 kA	50 kA	65 kA	75 kA	100 kA
Type of circuit breaker	Compact NS		NS800N <b>NS1000N</b> NS1250N	NS800H <b>NS1000H</b> NS1250H			NS800LB	
	Masterpact MTZ1	MTZ1 08 H1/H2/L1 <b>MTZ1 10 H1/H2/L1</b> MTZ1 12 H1/H2	MTZ1 08 H1/H2 <b>MTZ1 10 H1/H2</b>					
	Masterpact MTZ2	MTZ2 08 N1/H1/H2/L1 <b>MTZ2 10 N1/H1/H2/L1</b> MTZ2 12 N1/H1/H2/L1			MTZ2 08 H1/H2/L1 <b>MTZ2 10 H1/H2/L1</b> MTZ2 12 H1/H2/L1			
	Masterpact NT			NT08H1/H2 <b>NT10H1/H2</b> NT12H1/H2				
	Masterpact NW			NW08N1 <b>NW10N1</b> NW12N1	NW08H1 <b>NW10H1</b> NW12H1			

Type of Canalis busbar trunking		KTA1000 Reinforced short-circuit level						
Isc max kArms		25 kA	30 kA	42 kA	50 kA	65 kA	75 kA	100 kA
Type of circuit breaker	Compact NS		NS800N <b>NS1000N</b> NS1250N	NS800H <b>NS1000H</b> NS1250H			NS800LB	
	Masterpact MTZ1	MTZ1 08 H1/H2/L1 <b>MTZ1 10H1/H2/L1</b> MTZ1 12 H1/H2	MTZ1 08 H1/H2 <b>MTZ1 10H1/H2</b>					
	Masterpact MTZ2	MTZ2 8 N1/H1/H2/L1 <b>MTZ2 10 N1/H1/H2/L1</b> MTZ2 12 N1/H1/H2/L1			MTZ2 8 H1/H2/L1 <b>MTZ2 10 H1/H2/L1</b> MTZ2 12 H1/H2/L1	MTZ2 8 H/L1 <b>MTZ2 10 L1</b> MTZ2 12 L1		
	Masterpact NT			NT08H1/H2 NT10H1/H2 NT12H1/H2				
	Masterpact NW			NW08N1 <b>NW10N1</b> NW12N1		NW08H1 <b>NW10H1</b> NW12H1		

Type of Canalis busbar trunking		KTA1250						
Isc max kArms		25 kA	30 kA	42 kA	50 kA	65 kA	75 kA	100 kA
Type of circuit breaker	Compact NS		NS1000N NS1250N NS1600N	NS1000H NS1250H NS1600H				
	Masterpact MTZ1	MTZ1 08 H1/H2/L1 MTZ1 12 H1/H2 MTZ1 16 H1/H2	MTZ1 08 H1/H2		NS1600bN			
	Masterpact MTZ2	MTZ2 10 N1/H1/H2/L1 MTZ2 12 N1/H1/H2/L1 MTZ2 16 N1/H1/H2/L1			MTZ2 10 H1/H2/L1 MTZ2 12 H1/H2/L1 MTZ2 16 H1/H2/L1			
	Masterpact NT			NT10H1/H2 NT12H1/H2 NT16H1/H2				
	Masterpact NW			NW10N1 NW12N1 NW16N1	NW10H1 NW12H1 NW16H1			

Type of Canalis busbar trunking		KTA1250 Reinforced short-circuit level						
Isc max kArms		25 kA	30 kA	42 kA	50 kA	65 kA	75 kA	100 kA
Type of circuit breaker	Compact NS		NS1000N NS1250N NS1600N	NS1000H NS1250H NS1600H				
	Masterpact MTZ1	MTZ1 08 H1/H2/L1 <b>MTZ1 12 H1/H2</b> MTZ1 16 H1/H2	MTZ1 08 H1/H2		NS1600bN	NS1600bN		
	Masterpact MTZ2	MTZ2 10 N1/H1/H2/L1 <b>MTZ2 12 N1/H1/H2/L1</b> MTZ2 16 N1/H1/H2/L1			MTZ2 10 H1/H2/L1 <b>MTZ2 12 H1/H2/L1</b> MTZ2 16 H1/H2/L1		MTZ2 10 L1 <b>MTZ2 12 L1</b> MTZ2 16 L1	
	Masterpact NT			NT10H1/H2 NT12H1/H2 NT16H1/H2				
	Masterpact NW			NW10N1 NW12N1 NW16N1	NW10H1 NW12H1 NW16H1	NW10H1 NW12H1 NW16H1	NW10L1 NW12L1 NW16L1	



### Canalis KTA

Type of Canalis busbar trunking		KTA1600						
Isc max kArms		25 kA	30 kA	42 kA	50 kA	65 kA	85 kA	100 kA
Type of circuit breaker	Compact NS		NS1250N NS1600N	NS1250H NS1600H		NS1600bN NS2000N		
	Masterpact MTZ1	MTZ1 12 H1/H2 MTZ1 16 H1/H2						
	Masterpact MTZ2	MTZ2 12 N1/H1/H2/L1 <b>MTZ2 16 N1/H1/H2/L1</b> MTZ2 20 N1/H1/H2/H3/L1			MTZ2 12 H1/H2/L1 <b>MTZ2 16 H1/H2/L1</b> MTZ2 20 H1/H2/H3/L1		MTZ2 12 L1 <b>MTZ2 16 L1</b> MTZ2 20 L1	
	Masterpact NT			NT12H1/H2 <b>NT16H1/H2</b>				
	Masterpact NW			NW12N1 <b>NW16N1</b>		NW12H1 <b>NW16H1</b> NW20H1	NW12L1 (≤ 75 kA) <b>NW16L1 (≤ 75 kA)</b> NW20L1 (≤ 75 kA)	
Type of Canalis busbar trunking		KTA1600 Reinforced short-circuit level						
Isc max kArms		25 kA	30 kA	42 kA	50 kA	65 kA	85 kA	100 kA
Type of circuit breaker	Compact NS		NS1250N NS1600N	NS1250H NS1600H		NS1600bN NS2000N		
	Masterpact MTZ1	MTZ1 12 H1/H2 MTZ1 16 H1/H2						
	Masterpact MTZ2	MTZ2 12 N1/H1/H2/L1 <b>MTZ2 16 N1/H1/H2/L1</b> MTZ2 20 N1/H1/H2/H3/L1			MTZ2 12 H1/H2/L1 <b>MTZ2 16 H1/H2/L1</b> MTZ2 20 H1/H2/H3/L1		MTZ2 12 H2/L1 MTZ2 16 H2/L1 MTZ2 20 H2/H3/L1	MTZ2 12 L1 <b>MTZ2 16 L1</b> MTZ2 20 L1
	Masterpact NT			NT12H1/H2 <b>NT16H1/H2</b>				
	Masterpact NW			NW12N1 <b>NW16N1</b>		NW12H1 <b>NW16H1</b> NW20H1	NW12H2 (≤ 75 kA) <b>NW16H2 (≤ 75 kA)</b> NW20H2 (≤ 75 kA)	NW12L1 <b>NW16L1</b> NW20L1
Type of Canalis busbar trunking		KTA2000						
Isc max kArms		25 kA	30 kA	42 kA	50 kA	65 kA	85 kA	100 kA
Type of circuit breaker	Compact NS		NS1600N	NS1600H		NS1600bN NS2000N NS2500N		
	Masterpact MTZ1	MTZ1 16 H1/H2						
	Masterpact MTZ2	MTZ2 16 N1/H1/H2/L1 <b>MTZ2 20 N1/H1/H2/H3/L1</b> MTZ2 25 H1/H2/H3			MTZ2 16 H1/H2/L1 <b>MTZ2 20 H1/H2/H3/L1</b>		MTZ2 16 L1 <b>MTZ2 20 L1</b>	
	Masterpact NT			NT16H1/H2				
	Masterpact NW			NW16N1		NW16H1 <b>NW20H1</b> NW25H1		NW16L1 <b>NW20L1</b>
Type of Canalis busbar trunking		KTA2000 Reinforced short-circuit level						
Isc max kArms		25 kA	30 kA	42 kA	50 kA	65 kA	85 kA	100 kA
Type of circuit breaker	Compact NS		NS1600N	NS1600H		NS1600bN NS2000N NS2500N		
	Masterpact MTZ1	MTZ1 16 H1/H2						
	Masterpact MTZ2	MTZ2 16 N1/H1/H2/L1 <b>MTZ2 20 N1/H1/H2/H3/L1</b> MTZ2 25 H1/H2/H3			MTZ2 16 H1/H2/L1 <b>MTZ2 20 H1/H2/H3/L1</b>		MTZ2 16 L1 MTZ2 20 H2/H3/L1 MTZ2 25 H2/H3	MTZ2 16 L1 <b>MTZ2 20 H3/L1</b> MTZ2 25 H3
	Masterpact NT			NT16H1/H2				
	Masterpact NW			NW16N1		NW16H1 <b>NW20H1</b> NW25H1	NW16H2 (≤ 75 kA) <b>NW20H2 (≤ 75 kA)</b> NW25H2 (≤ 75 kA)	NW16L1 <b>NW20H3</b> NW25H3
Type of Canalis busbar trunking		KTA2500						
Isc max kArms		25 kA	30 kA	42 kA	50 kA	65 kA	80 kA	100 kA
Type of circuit breaker	Compact NS					NS2000N NS2500N NS3200N		
	Masterpact MTZ1	MTZ1 16 H1/H2						
	Masterpact MTZ2	MTZ2 20 N1/H1/H2/H3/L1 <b>MTZ2 25 H1/H2/H3</b> MTZ2 32 H1/H2/H3			MTZ2 20 H1/H2/H3/L1		MTZ2 20 H2/H3/L1 MTZ2 25 H2/H3 MTZ2 32 H2/H3	MTZ2 20 L1
	Masterpact NT			NT16H1/H2				
	Masterpact NW					NW20H1 <b>NW25H1</b> NW32H1	NW20H2 <b>NW25H2</b> NW32H2	NW20L1

Type of Canalis busbar trunking		KTA2500 Reinforced short-circuit level							
Isc max kArms		25 kA	30 kA	42 kA	50 kA	65 kA	85 kA	100 kA	
Type of circuit breaker	Compact NS					NS2000N NS2500N NS3200N			
	Masterpact MTZ1	MTZ1 16 H1/H2							
	Masterpact MTZ2	MTZ2 20 N1/H1/H2/H3/L1			MTZ2 20 H1/H2/H3/L1		MTZ2 20 H2/H3/L1	MTZ2 20 H3/L1	MTZ2 20 H3/L1
		<b>MTZ2 25 H1/H2/H3</b> MTZ2 32 H1/H2/H3							
	Masterpact NT			NT16H1/H2					
Masterpact NW						NW20H1 <b>NW25H1</b> NW32H1	NW20H2 (≤ 80 kA) <b>NW25H2 (≤ 80 kA)</b> NW32H2 (≤ 80 kA)	NW20H3 <b>NW25H3</b> NW32H3	
Type of Canalis busbar trunking		KTA3200							
Isc max kArms		25 kA	30 kA	42 kA	50 kA	65 kA	85 kA	100 kA	
Type of circuit breaker	Compact NS					NS2500N NS3200N			
	Masterpact MTZ2	<b>MTZ2 32 H1/H2/H3</b> MTZ2 40 H1/H2/H3						<b>MTZ2 32 H2/H3</b> MTZ2 40 H2/H3	
	Masterpact MTZ3	MTZ3 40 H1/H2							
	Masterpact NW					NW25H1 <b>NW32H1</b> NW40H1	NW25H2 <b>NW32H2</b> NW40H2 NW40b H1/H2		
Type of Canalis busbar trunking		KTA3200 Reinforced short-circuit level							
Isc max kArms		25 kA	30 kA	42 kA	50 kA	65 kA	85 kA	100 kA	
Type of circuit breaker	Compact NS					NS2500N NS3200N			
	Masterpact MTZ2	<b>MTZ2 32 H1/H2/H3</b> MTZ2 40 H1/H2/H3						<b>MTZ2 32 H2/H3</b> MTZ2 40 H2/H3	<b>MTZ2 32 H3</b> MTZ2 40 H3
	Masterpact MTZ3	MTZ3 40 H1/H2							
	Masterpact NW					NW25H1 <b>NW32H1</b> NW40H1	NW25H2 <b>NW32H2</b> NW40H2	NW25H3 <b>NW32H3</b> NW40H3 NW40bH1/2	
Type of Canalis busbar trunking		KTA4000							
Isc max kArms		25 kA	30 kA	42 kA	50 kA	65 kA	85 kA	100 kA	
Type of circuit breaker	Compact NS					NS3200N			
	Masterpact MTZ2	MTZ2 32 H1/H2/H3 MTZ2 40 H1/H2/H3						MTZ2 32 H2/H3 MTZ2 40 H2/H3	
	Masterpact MTZ3	<b>MTZ3 40 H1/H2</b> MTZ3 50 H1/H2							
	Masterpact NW					NW32H1 <b>NW40H1</b>	NW32H2 <b>NW40H2</b> <b>NW40bH1/H2</b> NW50 H1/H2		
Type of Canalis busbar trunking		KTA4000 Reinforced short-circuit level							
Isc max kArms		25 kA	30 kA	42 kA	50 kA	65 kA	85 kA	100 kA	
Type of circuit breaker	Compact NS					NS3200N			
	Masterpact MTZ2	MTZ2 32 H1/H2/H3 MTZ2 40 H1/H2/H3						MTZ2 32 H2/H3 MTZ2 40 H2/H3	MTZ2 32 H3 MTZ2 40 H3
	Masterpact MTZ3	<b>MTZ3 40 H1/H2</b> MTZ3 50 H1/H2							
	Masterpact NW					NW32H1 <b>NW40H1</b>	NW32H2 <b>NW40H2</b>	NW32H3 <b>NW40H3</b> <b>NW40bH1/H2</b> NW50H1/H2	
Type of Canalis busbar trunking		KTA5000							
Isc max kArms		25 kA	30 kA	42 kA	50 kA	65 kA	85 kA	100 kA	
Type of circuit breaker	Masterpact MTZ2					MTZ2 32 H1/H2/H3 MTZ2 40 H1/H2/H3	MTZ2 32 H2/H3 MTZ2 40 H2/H3	MTZ2 32 H3 MTZ2 40 H3	
	Masterpact MTZ3					MTZ3 40 H1/H2 <b>MTZ3 50 H1/H2</b> MTZ3 63 H1/H2			



### Canalis KTA

A

Standard IEC 60364-5-51 categorises a large number of external influences to which electrical installations can be subjected, for instance the presence of water, solid objects, shocks, vibrations and corrosive substances. The importance of these influences depends on the installation conditions. For example, the presence of water can vary from a few drops to total immersion.

### Degree of protection IP

B

Standard IEC 60529 (February 2001) indicates the degree of protection provided by electrical equipment enclosures against accidental direct contact with live parts and against the ingress of solid foreign objects or water.

This standard does not apply to protection against the risk of explosion or conditions such as humidity, corrosive gases, fungi or vermin.

The IP code comprises 2 characteristic numerals and may include an additional letter when the actual protection of persons against direct contact with live parts is better than that indicated by the first numeral.

The first numeral characterises the protection of the equipment against penetration of solid objects and the protection of people. The second numeral characterises the protection of the equipment against penetration of water with harmful effects.

#### Remarks concerning the degree of protection IP

The degree of protection IP must always be read and understood numeral by numeral and not as a whole.

For example, an IP31 enclosure is suitable for an environment that requires a minimum degree of protection IP21. However an IP30 wall-mount enclosure is not suitable.

The degrees of protection indicated in this catalogue are valid for the enclosures as presented. However, the indicated degree of protection is guaranteed only when the installation and device mounting are carried out in accordance with professional standard practice.

#### Additional letter

Protection of persons against direct contact with live parts.

The additional letter is used only if the actual protection of persons is higher than that indicated by the first characteristic numeral of the IP code.

If only the protection of persons is of interest, the two characteristic numerals are replaced by the letter "X", e.g. IPxxB.

### Degree of protection IK

G

Standard IEC 62-262 defines a coding system (IK code) indicating the degree of protection provided by electrical equipment enclosures against external mechanical impact.

Installation standard IEC 60-364 provides a cross-reference between the various degrees of protection and the environmental conditions classification, relating to the selection of equipment according to external factors.

#### IK code●●

The IK code comprises 2 characteristic numerals (e.g. IK05).

Practical guide UTE C 15-103 shows, in the form of tables, the characteristics required for electrical equipment (including minimum degrees of protection), according to the locations in which they are installed.

### Meaning of the numerals and letters representing the degree of protection IP.

The Canalis KTA busbar trunking products are designed to provide **IP55D** and **IK08** protection.

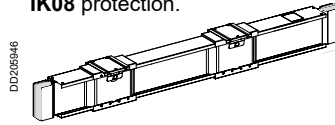

1<sup>st</sup> characteristic numeral: corresponds to protection of equipment against penetration of solid objects and protection of persons against direct contact with live parts.

Protection of equipment	Protection of persons	
Non-protected.	Non-protected.	<b>0</b>
Protected against the penetration of solid objects having a diameter greater than or equal to 50 mm.	Protected against direct contact with the back of the hand (accidental contact).	<b>1</b> DD210014 Ø 50 mm
Protected against the penetration of solid objects having a diameter greater than or equal to 12.5 mm.	Protected against direct finger contact.	<b>2</b> DD210015 Ø 12,5 mm
Protected against the penetration of solid objects having a diameter greater than or equal to 2.5 mm.	Protected against direct contact with a 2.5 mm diameter tool.	<b>3</b> DD210016 Ø 2,5 mm
Protected against the penetration of solid objects having a diameter greater than 1 mm.	Protected against direct contact with a 1 mm diameter wire.	<b>4</b> DD210017 Ø 1 mm
Dust protected (no harmful deposits).	Protected against direct contact with a 1 mm diameter wire.	<b>5</b> DD210018
Dust tight.	Protected against direct contact with a 1 mm diameter wire.	<b>6</b> DD210019

2<sup>nd</sup> characteristic numeral: corresponds to protection of equipment against penetration of water with harmful effects.

Protection of equipment	
Non-protected.	<b>0</b>
Protected against vertical dripping water (condensation).	<b>1</b> DD210006
Protected against dripping water at an angle of up to 15°.	<b>2</b> DD210007 15°
Protected against rain at an angle of up to 60°.	<b>3</b> DD210008 60°
Protected against splashing water in all directions.	<b>4</b> DD210009
Protected against water jets in all directions. Test duration: 1 mn/m <sup>2</sup> casing	<b>5</b> DD210010
Protected against powerful jets of water and waves.	<b>6</b> DD210011
Protected against the effects of temporary immersion.	<b>7</b> DD210012 1m
Protected against the effects of prolonged immersion under specified conditions.	<b>8</b> DD210013 m

### Additional letter

Corresponds to protection of persons against direct contact with live parts.

<b>A</b>	With the back of the hand.
<b>B</b>	With the finger.
<b>C</b>	With a 2.5 mm diameter tool
<b>D</b>	With a 1 mm diameter tool

### Degrees of protection IK against mechanical impact

The IK code comprises 2 characteristic numerals corresponding to a value of impact energy, in joules.

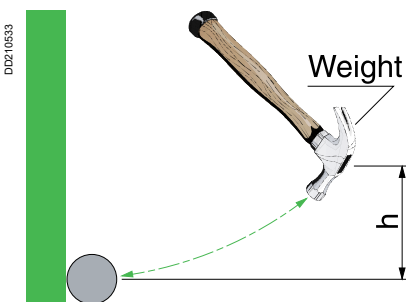

	Weight (kg)	Height (cm)	Energy (J)
00	Non-protected		
01	0.20	7.50	0.15
02		10	0.20
03		17.50	0.35
04		25	0.50
05		35	0.70
06	0.50	20	1
07		40	2
<b>08</b>	<b>1.70</b>	<b>30</b>	<b>5</b>
09	5	20	10
10		40	20

### Canalis KTA

#### Origin of harmonic currents

A

B

C

D

E

F

G

#### Estimating THD (total harmonic distortion)

Harmonic currents are caused by non-linear loads connected to distribution systems, i.e. by loads that draw current with a waveform different than that of the voltage that supplies them.

The most common non-linear loads are equipment including rectifiers, fluorescent lighting and computer hardware.

In installations with a distributed neutral, non-linear loads may cause significant overloads in the neutral conductor due to the presence of third-order harmonics.

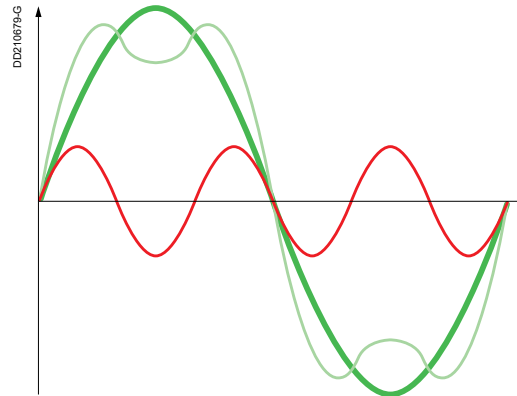

**Harmonic order**  
The order is the ratio between the harmonic frequency  $f_n$  and the fundamental frequency (generally the power frequency, 50 or 60 Hz):  
 $n = f_n / f_1$

By definition, the fundamental  $f_1$  is order 1 (H1).

Third-order harmonics (H3) have a frequency of 150 Hz (when  $f_1 = 50$  Hz).

The presence of third-order harmonics depends on the applications involved. It is necessary to carry out an in-depth study on each non-linear load to determine the level of H3:

$$ih3 (\%) = 100 \times i3 / i1$$

- $i3$  = rms current of H3
- $i1$  = rms current of the fundamental

Assuming that H3 is preponderant among harmonics, the THD is close to the value of H3 ( $ih3(\%)$ ).

There are two decisive factors:

- the types of connected devices:
  - disturbing loads: fluorescent lighting, computer hardware, rectifiers, arc furnaces, etc.
  - non-disturbing loads: heating, motors, pumps, etc.
- the ratio between the two types of disturbing loads.

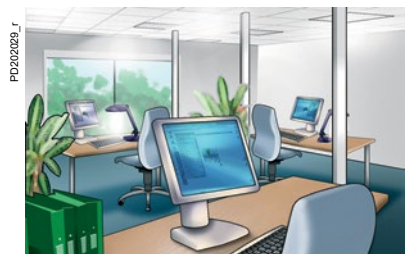

#### Workshops

Mix of disturbing loads (computers, UPSs, fluorescent lighting) and non-disturbing loads (motors, pumps, heating).

Low probability of harmonics  
**THD ≤ 15 %.**

#### Offices

Numerous disturbing loads (computers, UPSs, fluorescent lighting).

High probability of harmonics  
**15 % < THD ≤ 33 %.**

### Effects of harmonics on Canalis busbar trunking

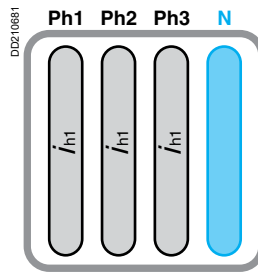

Fundamental frequency:  $i_{h1}$  (50 Hz)

No current in the neutral.  
The conductors are correctly sized.

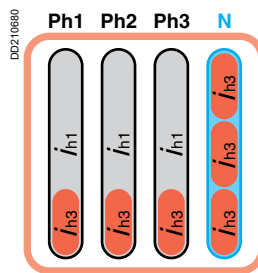

Fundamental frequency:  $i_{h1}$  (50 Hz) and 33 % of H3

Abnormal temperature rise in the conductors caused by current at a higher frequency in the phases (skin effect) and current in the neutral caused by summing of the H3 harmonics.

### The only effective solution

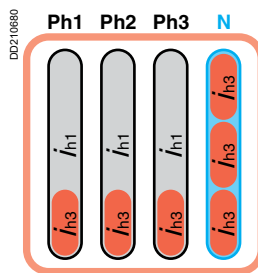

Fundamental frequency:  $i_{h1}$  (50 Hz) and 33 % H3



Reduce the current density in ALL conductors by using appropriately sized trunking.

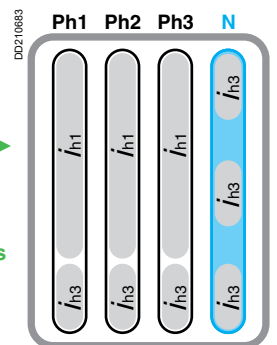

### Busbar-trunking selection

THD ≤ 15 %	15 % < THD ≤ 33 %	THD > 33 %	Busbar trunking	Rating (A)
800	630	500	KTA	800
1000	800	630	KTA	1000
1250	1000	800	KTA	1250
1600	1250	1000	KTA	1600
2000	1600	1250	KTA	2000
2500	2000	1600	KTA	2500
3200	<b>2500</b>	2000	KTA	3200
4000	3200	2500	KTA	4000

**Example:** for a total rms current of 2356 A (estimation based on power drawn by loads, including harmonics), the operational current is **2500 A**. THD is estimated at 30 %. The appropriate trunking is KTA 3200 A.

### For more information on harmonics

See the Cahier Technique publications on the Schneider Electric web site: [www.se.com](http://www.se.com)

### Canalis KTA

#### Determining the DC current value

A

B

C

D

E

F

G

#### Thermal effect

##### Rule

The total power dissipated as heat must remain constant in the duct:  
 $P_{ac} = P_{dc}$

Where:

- the power dissipated as heat:  $P_{ac} = 3 \times R \times I_{ac}^2$  where:
  - R= resistance of a conductor
  - $I_{ac}$  = conductor rms current
- the dissipated power for 4 conductors:  $P_{dc} = 4 \times R \times I_{dc}^2$  where:
  - $I_{dc}$  = direct current.

#### Selection table

##### ■ 1 source

Case of 2 conductors in parallel for the + and 2 conductor in parallel for the - (only 1 circuit in the busbar trunking):

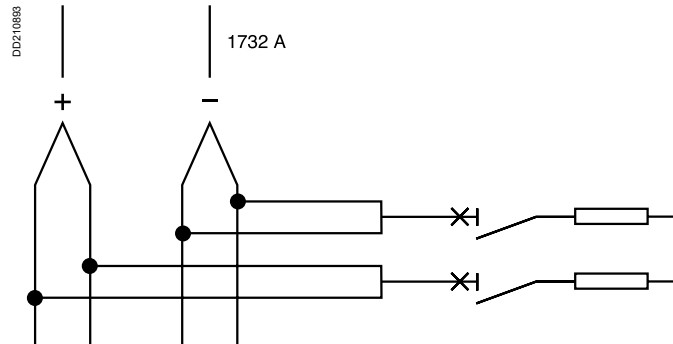

##### ■ 2 sources

Case of 1 conductor for the + and 1 conductor for the - (2 circuits possible in the same busbar trunking):

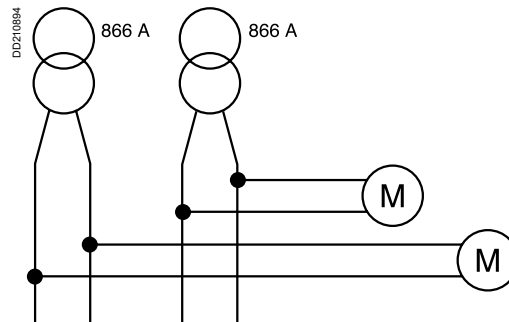

Busbar trunking rating (A)	1 source	2 sources
800	1386	693
1000	1732	866
1250	2165	1083
1600	2771	1385
2000	3464	1732
2500	4330	2165
3200	5542	2771
4000	6928	3464
5000	8660	4330

### Protection

With DC, there is no zero crossing point of the voltage and current to facilitate arc extinction in the protective device.

The arcing time is longer and the energy that has to be absorbed is higher than for AC.

The voltage of the DC arc must rise to the source voltage very quickly in order to "put out" the short-circuit current.

"Shortened" electrical equation:  $U_{network} = R \times I_{sc} + U_{arc}$  where:

- $I_{sc} = (U_{network} - U_{arc}) / R$
- $I_{sc} = 0$  when  $U_{arc} = U_{network}$ .

### Use with specific switchgear

A quick rise in arcing voltage can be achieved by using series fuses, one fuse on the + and one fuse on the – of each circuit.

For some current rating and fuse characteristics, the placing of two fuses in series on each polarity may be specified (highly inductive circuit).

In some cases, two fuses must be placed in parallel for each polarity.

### Saline environment

For use in a saline environment, storage and installation precautions must be followed.

Please contact your sales office.

A

B

C

D

E

F

G

**Canalis KTA**

**KT busbar trunking derating at 400 Hz**

Values at 35 °C.  
 Application of a derating coefficient at 400 Hz combined with that for temperature derating.

Busbar trunking derating								
	KTA08	KTA10	KTA12	KTA16	KTA20	KTA25	KTA32	KTA40
In (A)	688	851	1014	1327	1635	2024	2394	3162
Coefficient K at 400 Hz	0.86	0.85	0.84	0.83	0.82	0.81	0.80	0.79

**Voltage drop**

3-phase voltage drop, in millivolts per metre and per amp 400 Hz with load spread over the run.  
 For a concentration of load at the end of a run (transport), the voltage drops are double those shown in the table below.

$\Delta U$ evenly spread (mV. A. m)								
	KTA08	KTA10	KTA12	KTA16	KTA20	KTA25	KTA32	KTA40
Cos $\Phi$ = 1.0	0.079	0.068	0.057	0.044	0.038	0.033	0.025	0.020
Cos $\Phi$ = 0.9	0.12	0.109	0.096	0.079	0.067	0.054	0.045	0.039
Cos $\Phi$ = 0.8	0.13	0.121	0.108	0.089	0.076	0.060	0.051	0.045

**Conductor characteristics**

Conductor impedance								
	KTA08	KTA10	KTA12	KTA16	KTA20	KTA25	KTA32	KTA40
Average ohmic resistance of phase and neutral conductors at In <sup>(1)</sup> Rb1ph (m $\Omega$ /m)	0.092	0.079	0.066	0.051	0.044	0.039	0.029	0.023
Average resistance at In and rated F(Hz) <sup>(1)</sup> Xph (m $\Omega$ /m)	0.14	0.128	0.120	0.104	0.088	0.064	0.059	0.056

(1) In line with the CENELEC RO.64.013 document.

A

B

C

D

E

F

G

# Measurements and metering Canalis part of StruxureWare

## Loads monitored by a power meter in tap-off units

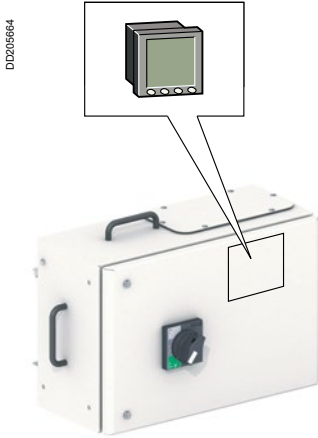

DD205947-G

Canalis offers measurement and metering units that can be mounted on both Canalis KS and KT trunking ranges, available in two ratings (250 A and 400 A). They are equipped with mounting plates designed to receive a PowerLogic PM810UMG Power Meter, a Compact NSx circuit breaker and the associated current transformers.

Data are collected by a Modbus serial communication bus and converted in Ethernet TCP/IP through an EGX gateway. Provided informations can easily be used in a supervision system.

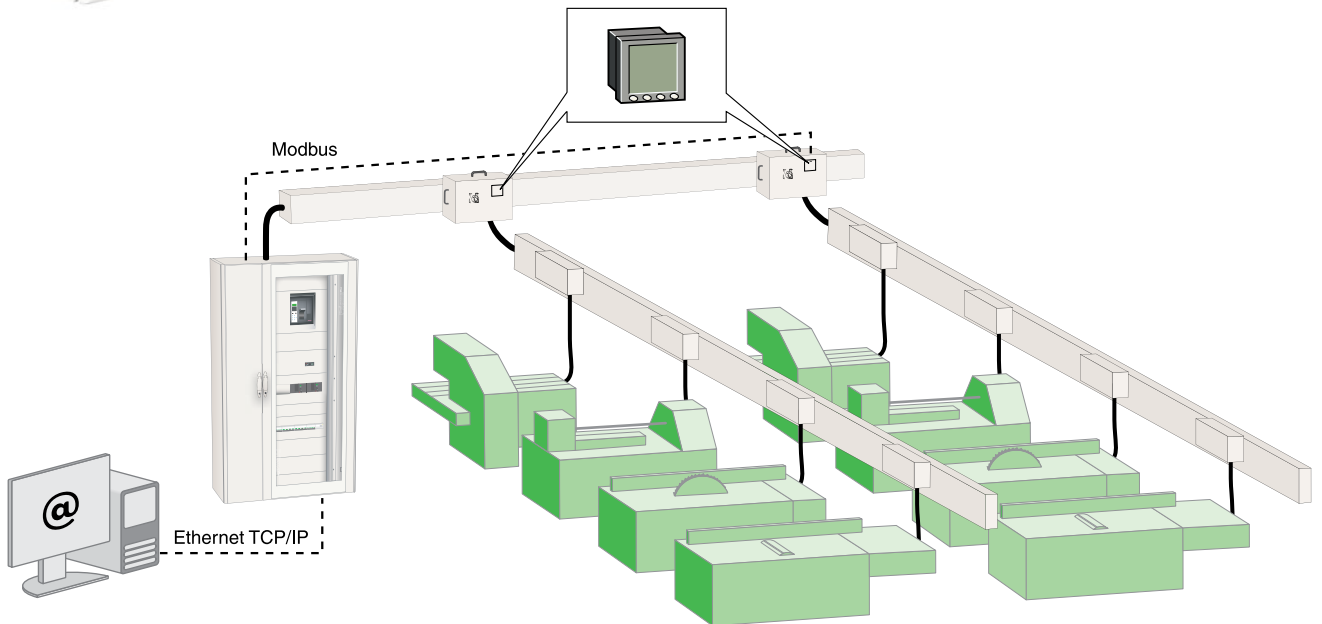

## Data acquisition in distributed architectures

When busbar trunking is located upstream of a secondary trunking line, the measurement devices should be installed in the tap-off units.

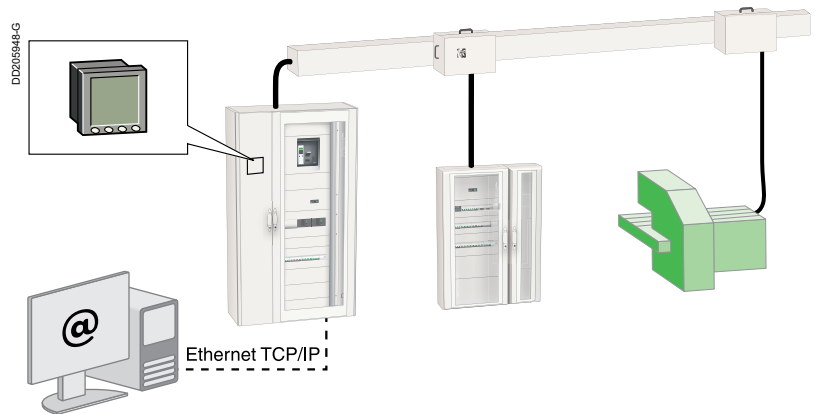

- A
- B
- C
- D**
- E
- F
- G

Canalis KTA

A

As required by standards, Canalis KT busbar trunking complies with:

- 1 - material resistance to abnormal temperatures,
- 2 - flame propagation resistance,
- 3 - fire barrier function when going through a partition wall,
- 4 - conservation of all circuits for 1h30 in an insulating sheath.

Definition of tests

B

### 1 - Insulating material resistance test to abnormal temperatures

**Objective**

To check a material will not be suspected as being the origin of a secondary fire outbreak.

As defined in standards § 8.1.3 IEC 61439-1 and IEC 60695-2-10 and 2-13.

**Method**

Application of an incandescent wire for 30 seconds on the insulating materials in contact with live parts.

**Result criteria**

The specimen is considered to have passed the incandescent wire test if:

- if there is no visible flame and no sustained incandescence
- the specimen's flames and incandescence go out within 30 seconds of the incandescent wire being removed.

C

D

### 2 - Flame propagation resistance test

**Objective**

To check a busbar trunking will not create secondary fire outbreaks.

As defined in standards § 10.101 IEC 61439-6 and IEC 60332 part 3.

**Method**

- Application of a flame for 40 minutes on a straight length of busbar trunking whose centre is located 2.5 metres from the edge of the burner.

**Result criteria**

The specimen is considered to have passed the test if:

- combustion does not occur
- the maximum extent of the burned part (external and internal) of the busbar trunking does not go beyond 2.5 metres above the lower edge of the burner.

E

F

G

### 3 - Fire barrier test through a partition wall

#### Objective

To check a busbar trunking will not propagate a fire from one room to another by crossing a fire barrier wall for 60, 120, 180, or 240 minutes.

As defined in standard EN 1366-3; EN 1363-1; ISO 834; DIN 4102 part 9.

#### Method

The fire barrier busbar trunking section to be tested is placed in an oven which executes a standardised temperature-time curve.

#### Result criteria

The specimen is considered to have passed the test if:

- there are no flames behind the fire barrier
- there is no smoke or gas behind the fire barrier (not requested by the standard; can appear as a remark in the test report)
- the temperature rise of the casing behind the fire barrier does not exceed 180°C.

### 4 - Conservation of all circuits in fire conditions test

#### Objective

To check all the busbar trunking's electrical circuits are preserved in fire conditions.

As defined in standard DIN 4102 part 12.

#### Method

Its entire length inserted, the busbar trunking is taken as a specimen in an insulating sheath.

#### Result criteria

The specimen is considered to have passed the test if:

- conductor continuity is preserved
- there is no short-circuit between conductors.

A

B

C

D

E

F

G

Canalis KTA

- A
- B
- C
- D
- E
- F
- G

Seismic zones worldwide

- zone 4
- zone 3
- zone 2
- zone 1
- zone 0

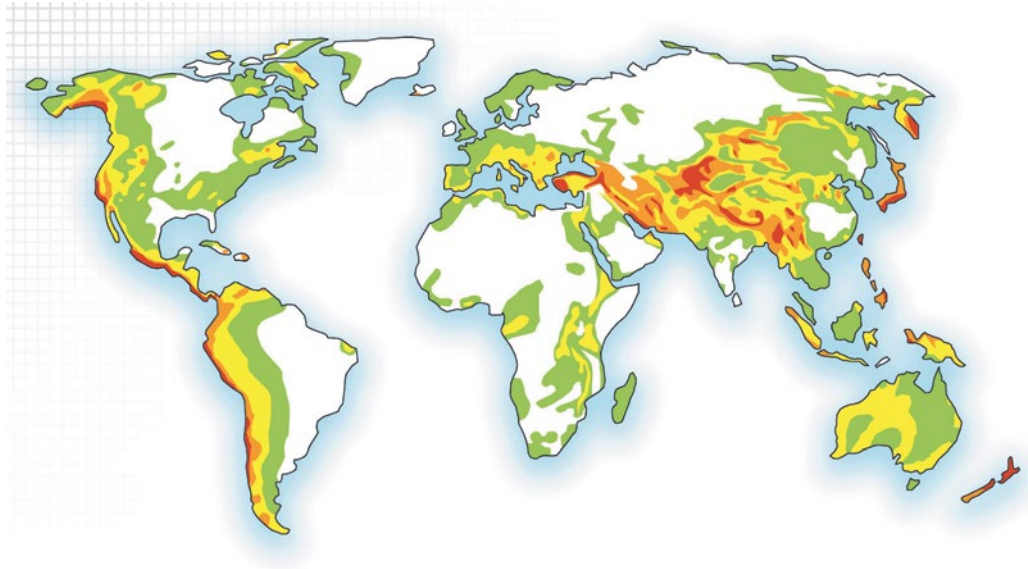

Canalis KT is seismic certified in accordance with the protocol described in IEC 60980 and a seismic level equivalent to >7 on the Richter scale and severity 9 on the international MSK- 64 scale. The spectrum used for testing is the one specified for civil engineering and nuclear applications in GOST 17516.1-90.

Spectrum according to GOST

GOST nuclear market spectra

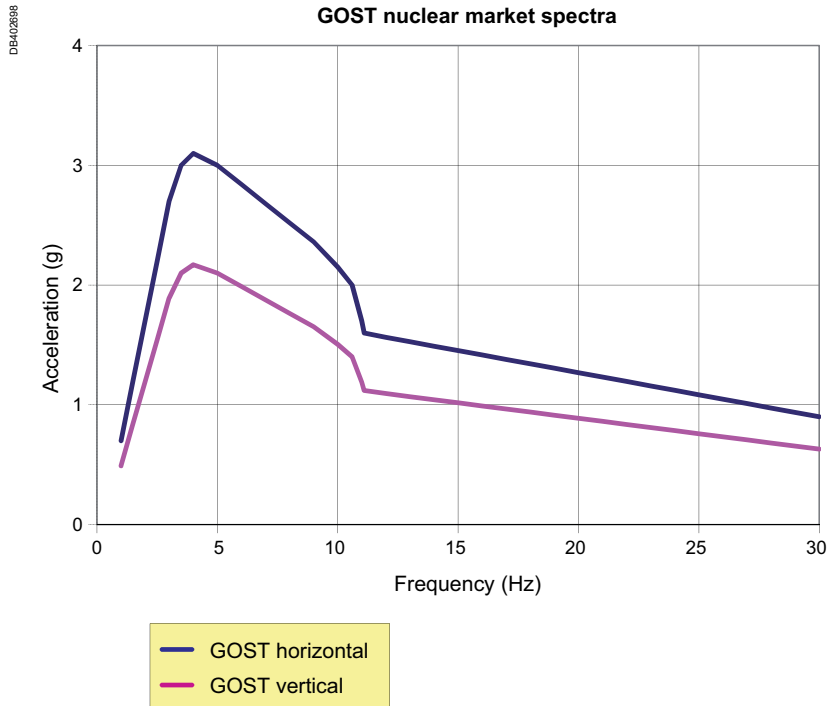

### Installation and support

Supports for conventional applications can be used for seismic applications by following the recommendations below:

■ For flexible support

Use supports and rods, with a minimum length of 1000 mm and additional clamping as per the following diagram.

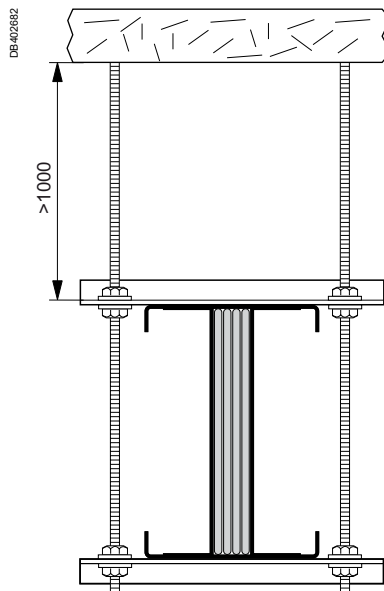

Safety limit: 250 mm round the busbar trunking (amplitude noted during testing).

■ For rigid support

Use of conventional mechanically welded consoles with rigid busbar trunking fastening.

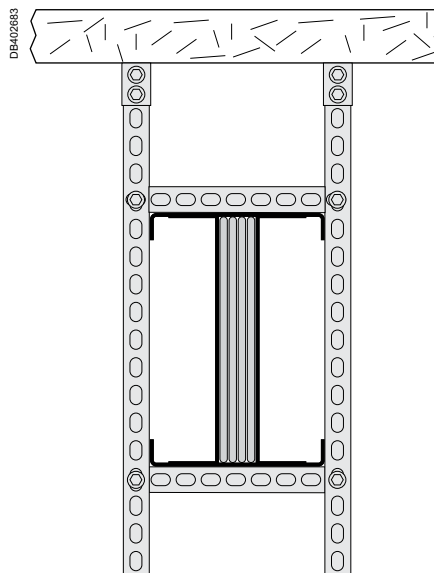

For both cases:

- its conventional fixing centre distances are maintained (3 m edgewise, 2 m flat)
- the levels achieved are applicable for horizontal, edgewise or flat or vertical installations.



# Testing and commissioning procedure

## Canalis KTA

A

B

C

D

E

F

G

### Equipment checking, positioning and identification

All the operations described below are given for indication only. Under no circumstances can they be used to substitute the installation company's own procedures and engage Schneider Electric's responsibility.

#### Scope

High power busbar trunking, transformer-switchboard links.

#### Required tools

- Multimeter.
- 500 V megger.
- Roto-phase.

#### Prerequisites

- If need be, the old equipment has been removed from the premises.
- The new equipment has been manoeuvred into the premises where it is to be installed by the installation contractor.
- The equipment has been installed by the installation contractor in accordance with manufacturer's recommendations.
- The equipment's installation diagram, connection diagram and assembly results sheet are available for the commissioning engineer.

#### De-energising the installation and making it safe

The works manager is responsible for worksite safety and must ensure the installation is de-energised and made safe in accordance with safety rules before any inspection or measurement is performed.

After the installation contractor has positioned, assembled and connected the busbar trunking in accordance with the supplied installation, assembly and connection diagrams, and using the recommended tools and handling equipment, the following characteristics must:

- be noted,
- be checked for compliance with respect to the details shown on the drawing.

Brand:	-	Busbar trunking rating:	-
Equipment type:	-	Serial number:	-
Reference:	-	Date of manufacture:	-
Transformer power:	-	Source circuit breaker (busbar trunking protection):	-

#### General visual inspection

The equipment has been chosen according to its electrical environment (rating and protection adapted to operating conditions). The following points do not require checking.

#### Points concerning reception, storage and handling

No signs of:

- shock (which may deteriorate internal insulation: conductor insulation on straight lengths or at the tap-off points or joint blocks)
- humidity or oxidation (equipment stored outside should have been covered with a plastic sheet, sheltered from humidity, dirt and dust)
- firm's label defining the product's characteristics.

# Testing and commissioning procedure

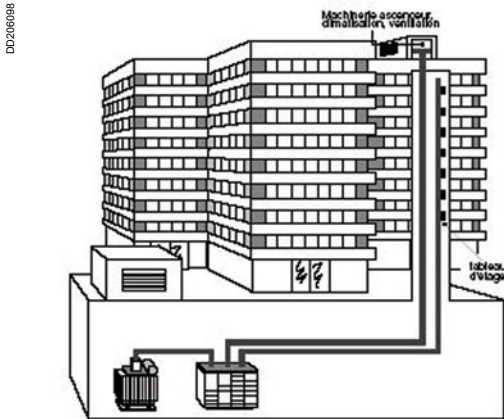

## Points concerning installation and fittings

Assembly compliance with the specifications of the installation drawing, service instructions and the catalogue:

- no busbar trunking twisting
- positioning and distance of the busbar trunking with respect to the building
- fixings, compliance of the between centres distance of the equipment for flat or edgewise, horizontal or vertical distribution
- clamps, not fully blocked to allow movement due to longitudinal forces
- presence of expansion sections if necessary.

## Checking power connections

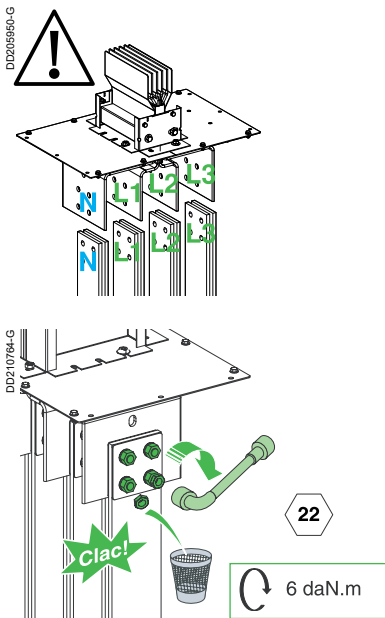

## General visual inspection

Check the number of connection parts and their cross-sections for each conductor (see "Installation guide").

Check insulation distances between 2 conductors and between conductors and metal panels.

Check the tightening torque of bolts not fitted with torque nuts. For bolts fitted with torque nuts, check the head has broken-off.

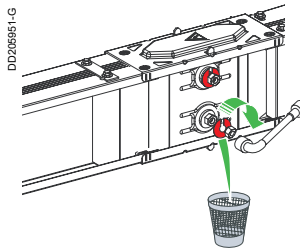

Check the bolt length exceeding the nut ; some bolts may have been removed and then put back, but left untightened.

Mark each tightened nut using indelible varnish. As well as a means of self-inspection to ensure correct tightening torque, it also allows any untightening to be identified.

Class 8-8 nuts and bolts (M8 on LV switchboard side, see "Commissioning Guide for Schneider Electric LV Switchboards").

Bolt	Tightening torque
HM16	16 daN.m
HM14	12 daN.m
HM12	7 daN.m
HM10	5 daN.m

The results of all these checks must be noted on the results sheet by the installation contractor.

## Checking insulation between live conductors

These measurements and checks can only be performed if:

- each link is disconnected by an isolating device,
- each link is disconnected from the upstream transformer, with the main circuit breaker upstream of the LV switchboard unplugged and in the open position.

**Test means:** 500 V DC megger (DC to avoid capacitive currents)

**Measurements:** 6 measurements between live conductors (between phases and then between each phase and neutral).

**LV circuit insulation value,** according to IEC 60364-6 (and 61.3.3) standard:

- rated voltage < 500 V      U test DC = 500 V      Ri ≥ 1 MΩ
- rated voltage > 500 V      U test DC = 1000 V      Ri ≥ 1 MΩ.

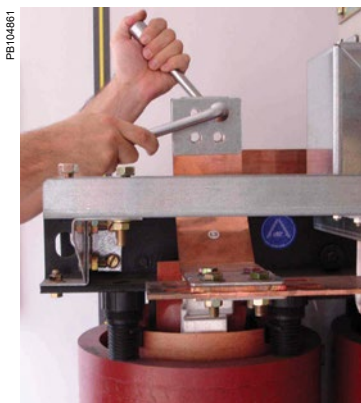

# Testing and commissioning procedure

## Canalis KTA

### Checking the earth network and locks

A

B

C

D

E

F

G



#### Earth network

##### General visual inspection

Check:

- the galvanised steel casing sides are earthed (note: this depends on the earthing system)
- connection quality
- cable cross-section
- there are no loose metal parts (washers, screws) in the tap-off units.

**Note:** the results of these checks must have already been noted on the results sheet by the installation contractor.

##### Checking insulation between live conductors and earth

Following this check, each link must be reconnected to the upstream transformer (use the 2<sup>nd</sup> available 6 daN.m torque bolt heads).

**Test means:** 500 V DC megger (DC to avoid capacitive currents)

**Measurements:** between each phase or neutral <sup>(1)</sup> and earth (the casing if it is connected to earth).

**LV circuit insulation value,** according to IEC 60364-6 (and 61.3.3) standard:

- rated voltage < 500 V    U test DC = 500 V    Ri ≥ 1 MΩ
- rated voltage > 500 V    U test DC = 1000 V    Ri ≥ 1 MΩ.

(1) No neutral insulation if the earthing system is such that the neutral is connected to or used as the earth.

**Caution:** in this case, once the transformer has been reconnected (star secondary), the phase-earth measurement is the winding resistance.

#### PE protective circuit equipotential

**Reference:** IEC 61439-1:

Check PE protective circuit continuity by visual inspection and random continuity testing.

The previously performed "phases-PE" insulation test must have been compliant.

**Test means:** ohmmeter.

#### Locks

To protect personnel by not allowing access to live parts through the use of locks. Only concerns key operated safety locks.

### Checking connections and auxiliary testing

Check not relevant to busbar trunking.

# Testing and commissioning procedure

## De-energised equipment operating tests

### Checking source circuit breaker protection settings

Compliance check in accordance with the installation drawing specifications:

- I<sub>max</sub> thermal
- I<sub>n</sub> magnetic.

**Note:** this check is only to be performed if the busbar trunking is commissioned at the same time as the transformer: the source circuit breaker protection setting checks are related to transformer commissioning.

Check not relevant if the transformer has already been commissioned.

**If this check is successful, the busbar trunking can be commissioned and the energised operating tests performed with the appropriate protective equipment**

## Commissioning and energised equipment operating tests

**Note: commissioning can only be carried out by personnel with appropriate authorisations.**

Preliminary operation: energising the off-load transformer.

**Closing the source circuit breaker.**

### Checking phase order

Objective: to detect, in order to correct, an inversion of the phases or neutral amongst the busbar trunking's 4 incoming and outgoing connections with respect to the transformer output.

**Test means:** roto-phase or 3-phase harmonic analyser.

If busbar trunking energising is successful, a progressive start-up of the factory must be requested to definitively validate commissioning.

**If unsuccessful, the previous checks must be carried out again to try and locate the fault. Before undertaking this, the equipment must once again be made safe.**

### Final putting into service test

This test is performed once the busbar trunking has been energised.

The progressive start-up of loads will highlight any undesirable phenomena due to the increased average load.

#### Real life operating test

Once the high power busbar trunking has been energised, the other busbar trunking must be gradually put into service starting with those furthest from the load, then each load itself, those with high pull-in currents, then the lighting, contactors, heating, motors, etc.

There must not be excessive vibration, and no sparkovers should be observed.

The test simply consists of checking correct busbar trunking operation according to:

- the average number of machines in operation
- the load variation of each individual load
- the simultaneous operation of machines (superimposing of peaks).

If everything is in order, the busbar trunking is declared "in-service". Testing is completed.

A

B

C

D

E

F

G

A

B

C

D

E

F

G

# Installation guide

Introduction	3
Presentation and description	23
Catalogue numbers and dimensions	47
Design guide	143
<b>Layout advice</b>	<b>186</b>
Run optimisation	186
Positioning and supports	189
Anticipate unexpected worksite problems	192
Tips for determining dimensions at the worksite	193
<b>Horizontal distribution</b>	<b>196</b>
Positioning the tap-off units	196
Tap-off units	197
Checking and compensating for expansion	198
<b>Rising mains</b>	<b>202</b>
General	202
Positioning the busbar trunking without external fire barrier	203
Positioning the tap-off units	204
Positioning of supports	205
Positioning the external fire barriers	206
Installation with feed via a cable box or direct onto the switchboard	207
<b>Panorama of connection solutions</b>	<b>210</b>
<b>Connection to LV switchboards</b>	<b>212</b>
Selection guide	212
By Canalis interface	214
By universal feed unit	220
By feed and connection plates	222
<b>Connection to cast resin transformers</b>	<b>226</b>
Selection guide	226
<b>Connection to Trihal Dry type transformers</b>	<b>228</b>
Selection guide	228
<b>Connection to Trihal cast resin transformers</b>	<b>229</b>
By Canalis interface	229
<b>Connection to cast resin transformers</b>	<b>231</b>
By universal feed and connection plates	231
<b>Connection to Minera immersed transformers</b>	<b>236</b>
Horizontal selection guide	236
Vertical selection guide	238
<b>Connection to oil immersed transformers</b>	<b>240</b>
By feed and connection plates or braids	240
Recommendations	243
Index	248

Canalis KTA

PowerSet Canalis Design software

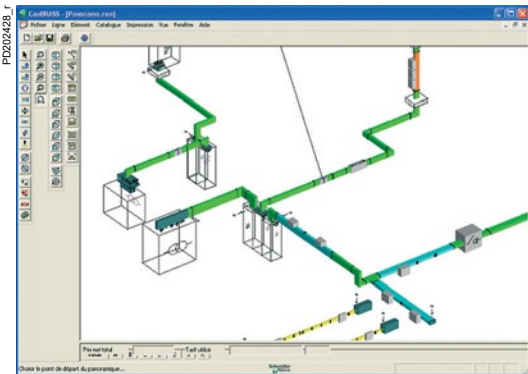

**PowerSet Canalis Design** software can be used to design the busbar trunking line. The easy-to-use program creates a graphic model of the line, determines the length and draws up the list of Canalis KT parts to order.

The Canalis KT line is easy to specify simply by indicating the required dimensions. However, it is strongly advised to use the shortest and simplest path possible between the transformer and the switchboard.

It is important to carefully plan the layout of the transformer and switchboard in order to use:

- the maximum number of standard components rather than made-to-measure components
- the minimum number of components for changing direction
- straight made-to-measure components rather than made-to-measure components for changing direction.

Advice

Before defining your busbar trunking run, it is recommended you pay particular attention to the various parameters which could be detrimental to the installation.

**Obstacles that obstruct the busbar trunking such as beams, pipes, etc.**

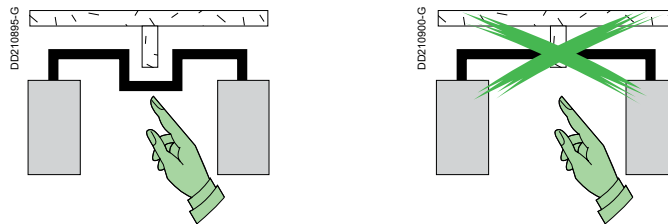

**Badly positioned places for going through walls and floors.**

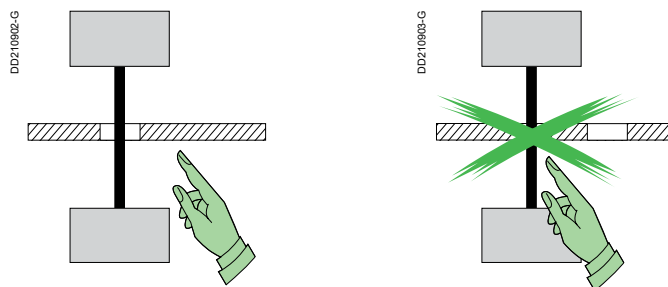

**Joint positions in the middle of a partition wall.**

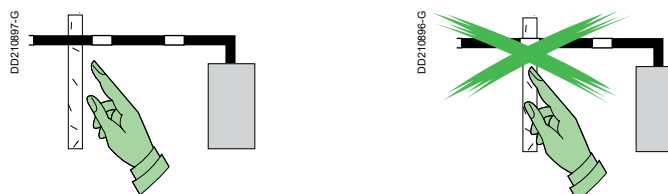

- A
- B
- C
- D
- E
- F
- G

**Insufficient ceiling height.**

If the busbar trunking must be installed edgewise between a transformer and switchboard, ensure the ceiling height is sufficient for fitting the joint blocks from the top.

Reserve a space between the busbar trunking and the ceiling equal to 100 mm (variable depending on the rating, see "Catalogue numbers and dimensions").

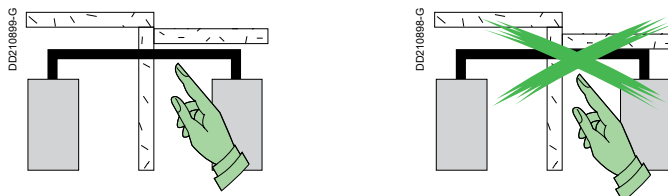

**Going through a floor to bottom feed a switchboard on the next floor.**

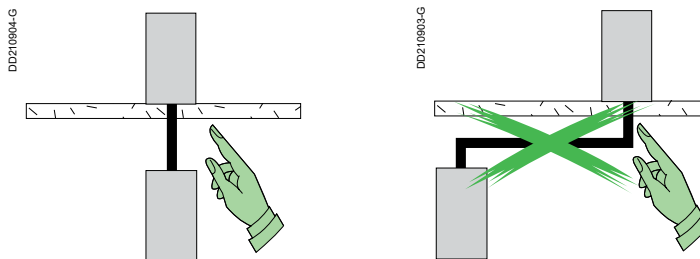

**Difference in floor levels of 2 rooms.**

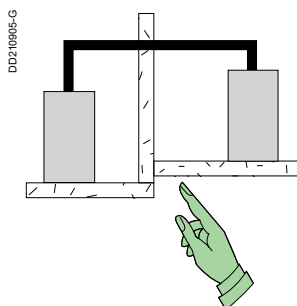

Also make sure that as the work progresses other tradesmen do not carry out installations that could hinder your initial layout.



Canalis KTA

Examples of link optimisation

A

B

C

D

E

F

G

**Example 1**

Reducing the number of changes of direction by modifying the switchboard or transformer layout.

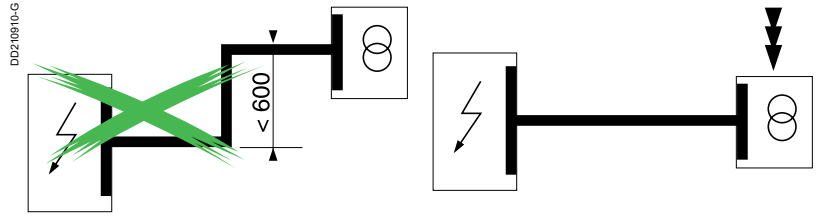

**Example 2**

Use of 2 standard elbows in place of a made to measure zed by increasing dimension "L".

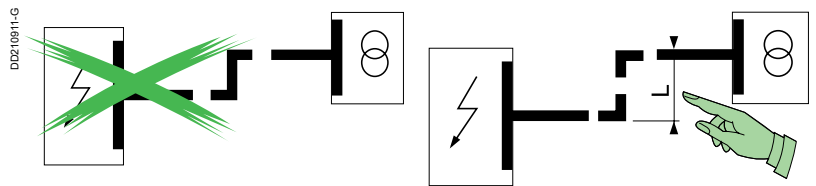

**Modification of the busbar trunking height**

By slightly increasing dimension "Z", replace a made to measure elbow feed connector with a standard feed connector and standard elbow section.

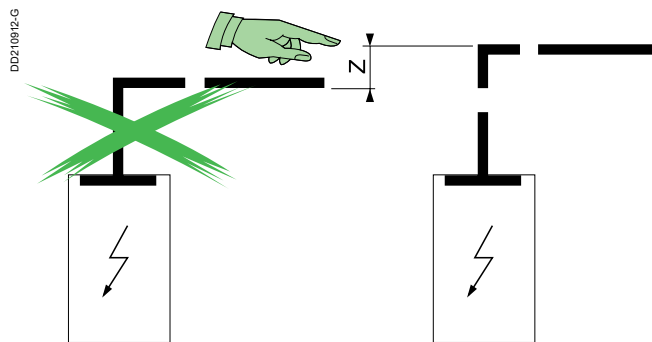

Neutral position

When choosing the layout of the electrical installation, it is important care is taken when positioning the neutral between the transformer and the switchboard. If the neutral position is different to that planned, it is recommended the transformer is moved, if possible, to align the neutral with respect to the switchboard's neutral. When it is not possible to move the transformer, it is recommended the phase order in the switchboard is inverted. If this cannot be done, use the phase and neutral transposition section.

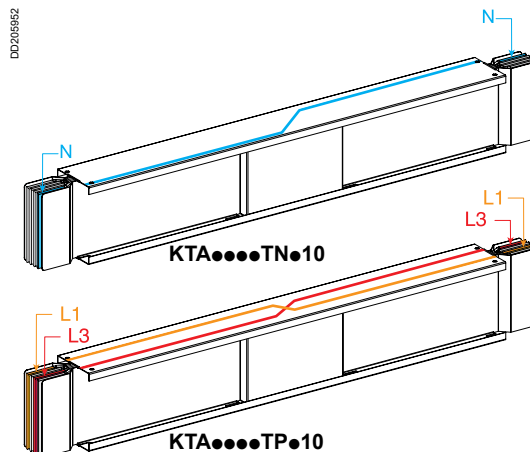

# Installation guide

## Layout advice

### Positioning and supports

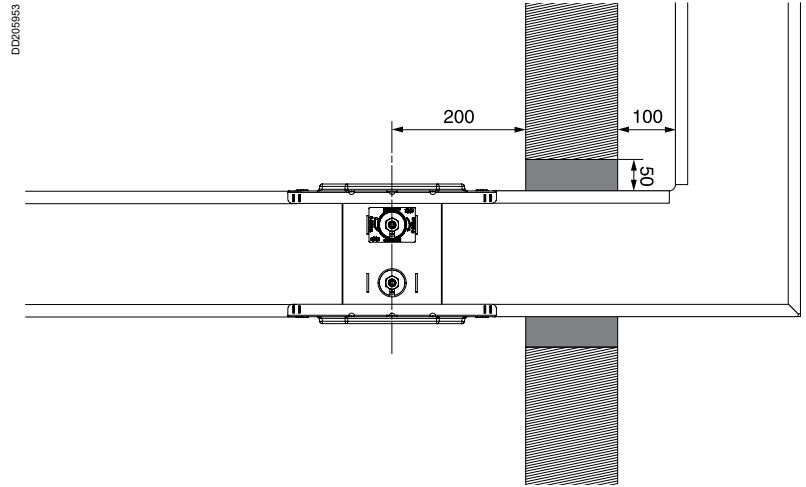

**Edgewise passage through partition wall**

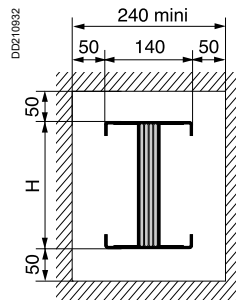

**Flat passage through partition wall**

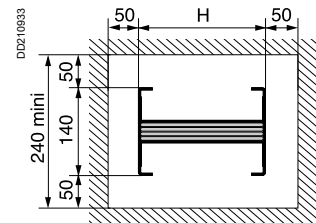

<b>Rating (A)</b>	800	1000	1250	1600	2000	2500	3200	4000	5000
<b>Height H (mm)</b>	74	104	124	164	204	244	324	404	2 x 244 + 130

**Edgewise passage through partition wall for 5000**

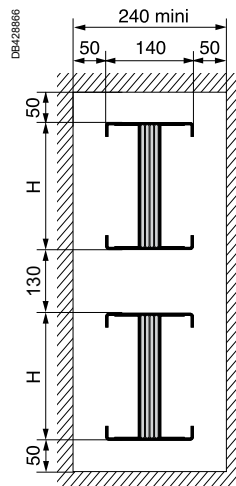

**Flat passage through partition wall for 5000**

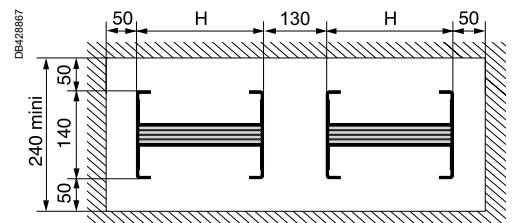

- A
- B
- C
- D
- E**
- F
- G

#### Canalis KTA

A

#### Edgewise horizontal installation

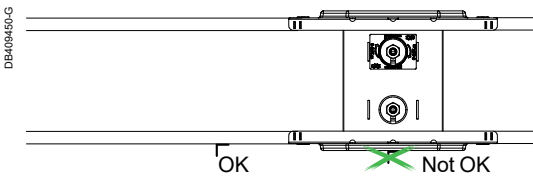

A support point as close as possible to the connections is needed because transformers, generator sets and switchboards must not support the weight of the busbar trunking. In some industries, for service continuity reasons, transformers may be replaced quickly. The busbar trunking must be able to support itself.

The maximum recommended distance between supports is 3 metres. In all cases, provide for 2 supports for 4 metre sections. For clamping busbar trunking to support brackets, see page 200.

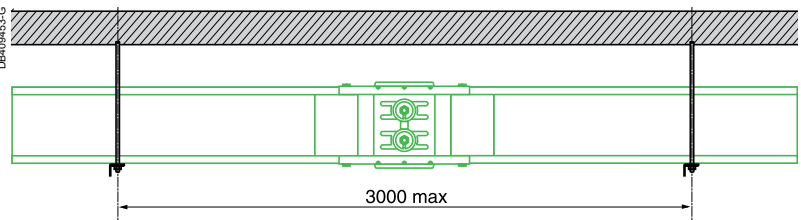

B

C

#### Flat horizontal installation

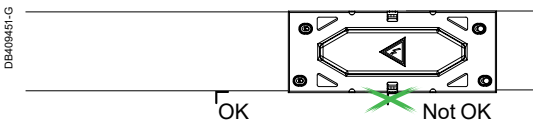

The recommended distance between supports is 2 metres. In addition, a support must be placed at 400 mm maximum from the joint block axis. For clamping busbar trunking to support brackets, see page 200.

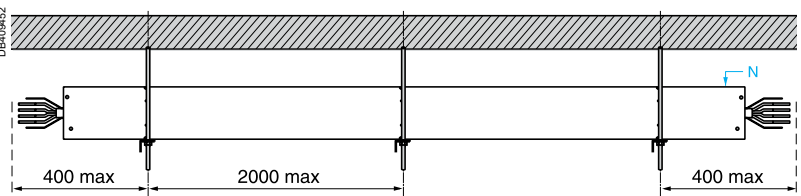

D

E

#### Example of spreading out supports

##### Supporting of LC elbow with a vertical branch

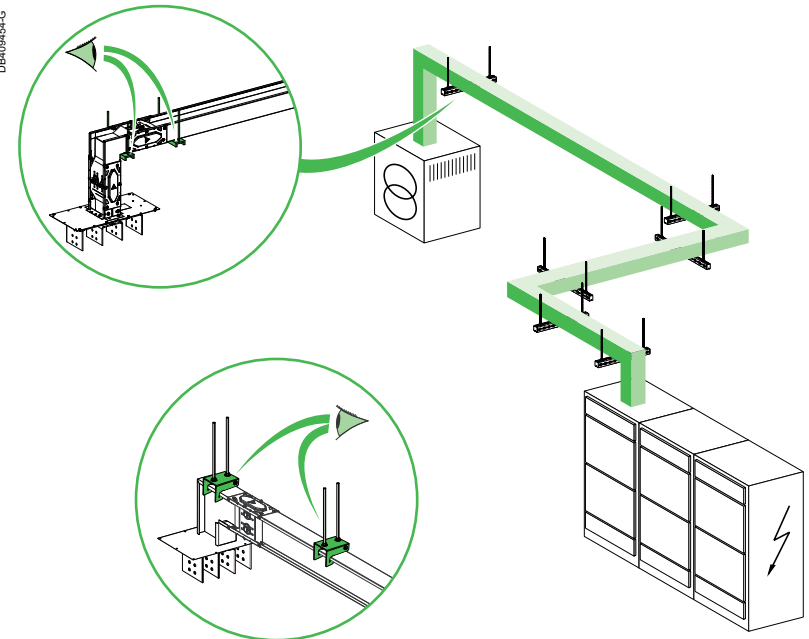
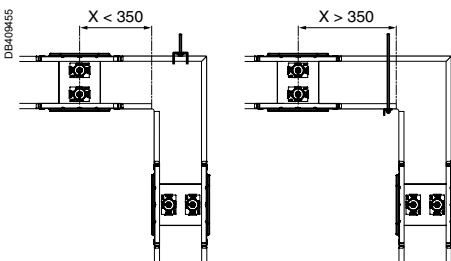

##### Supporting of LP elbow with a vertical branch

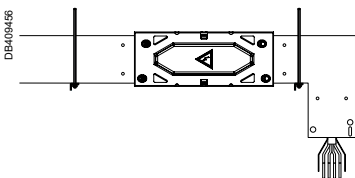

##### Supporting of LC elbows and TC tees (top view)

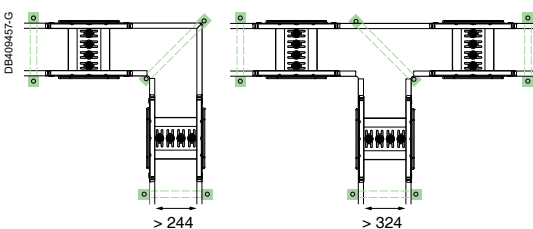

#### Rules to follow

- An element must never be left unsupported.
- For easier leveling, always use two supports for each element wherever possible.
- A bracket must never coincide with a junction block.
- The capacity of fixing brackets in terms of supporting is at least the weight of the busbar trunking system plus 90 kg, in accordance with IEC 61439-6.
- Terminals must be fixed by its own brackets not be supported by transformers or switchboards.
- Vertical branches must be always supported the closer as possible to the elbow angle.
- Elbows and zeds must be supported individually.
- Supports must be installed close to junctions.

# Installation guide

## Layout advice

### Positioning and supports

#### Defining the layout, dimensions to be provided

The position of the joint block with respect to the transformer axes and switchboard edges (defined in the "Installation guide").

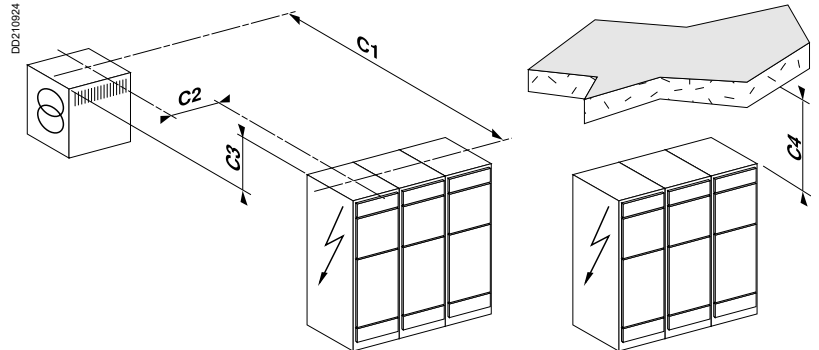

#### Distance of the busbar trunking from the wall

##### Edgewise installation

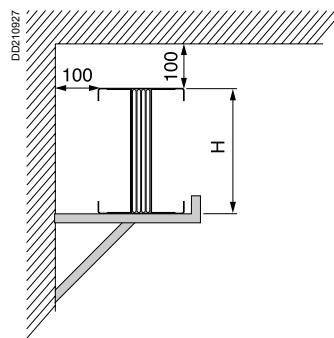

##### Flat installation

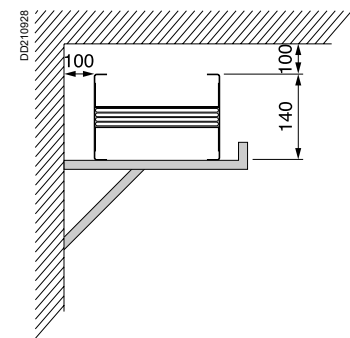

Rating (A)	800	1000	1250	1600	2000	2500	3200	4000	5000
Height H (mm)	74	104	124	164	204	244	324	404	2 x 244 + 130

#### Distance between busbar trunking (without tap-off units)

##### Edgewise installation

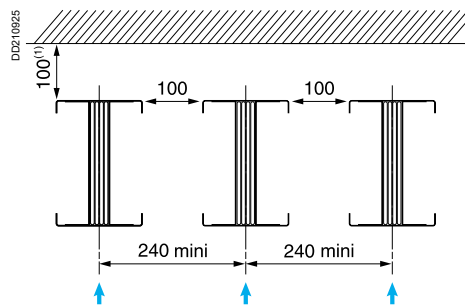

(1) Provide 2 times the height if the joint block must be fitted from the top.  
 → Direction of fitting joint blocks.

##### Flat installation

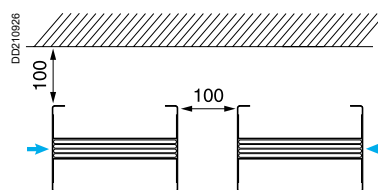

→ Direction of fitting joint blocks.

# Installation guide

## Layout advice

### Anticipate unexpected worksite problems

#### Canalis KTA

#### Undecided section

- A
- B
- C
- D
- E
- F
- G

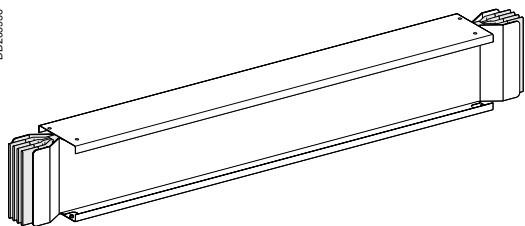

This section will be ordered after the gap to be filled has been measured at the end of the job. To optimise its delivery to site, prefer a straight section with a length of less than 2 metres rather than made to measure elbows.

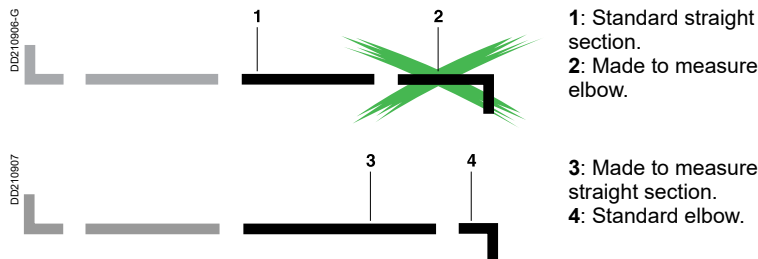

On the drawing, provide a minimum dimension of 700 mm to guarantee an adjustment of  $\pm 200$  mm on-site. The minimum length of straight sections being equal to 500 mm.

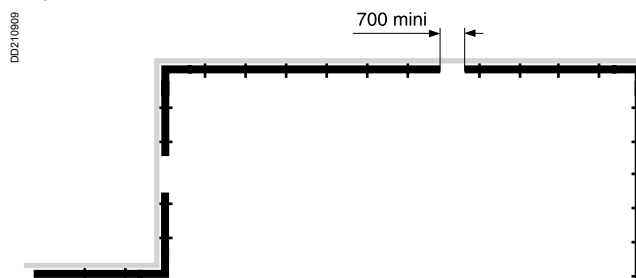

#### Layout recommendations for adjustable or undecided sections

In order to provide for the place needed for undecided section, install the elbows and the sections attached to the elbows in each angle (support each assembly using 2 supports on each straight section).

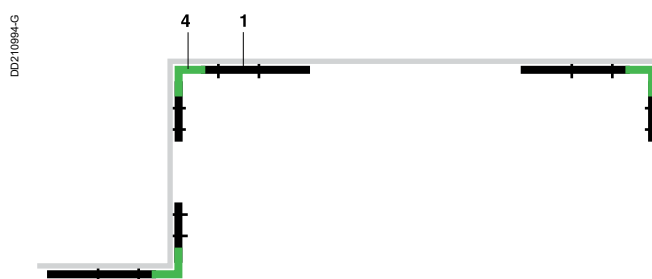

And then complete the layout with standard and made to measure straight sections.

# Tips for determining dimensions at the worksite

## Straight section

The nominal length "L" of a straight section is measured from the axis of the joint block to the other axis of the joint block, in millimetres (the joint block axis is located 20 mm from the end of the bars).

Dimension L of the standard or made to measure section =  $x - 40$  mm.

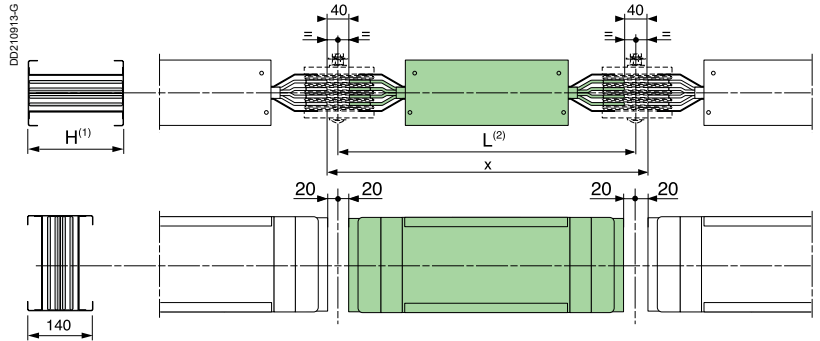

- (1) For the different busbar trunking heights, see page 191.
  - (2) See "Run sections" in "Catalogue numbers and Dimensions".
- x: measured dimension.

**Example:**  $x = 1860$  mm hence  $L = 1860 - 40 = 1820$  mm.

## Change-of-directions

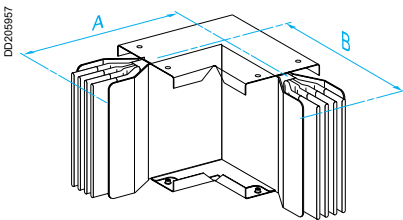

A and B: see "Changes of direction" in "Catalogue numbers and Dimensions".

## Flat elbows

The nominal length of each branch is measured from the axis of the joint block to the axis of the other branch, in millimetres. The joint block axis is located 20 mm from the end of the bars.

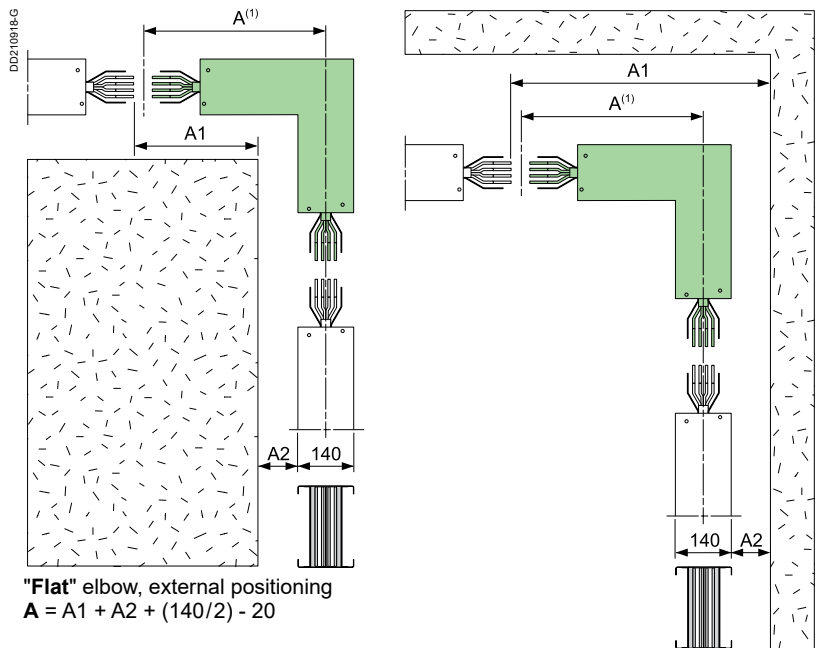

"Flat" elbow, external positioning  
 $A = A1 + A2 + (140/2) - 20$

"Flat" elbow, internal positioning  
 $A = A1 - A2 - (140/2) - 20$

(1) See "Changes of direction" in "Catalogue numbers and Dimensions".

# Layout advice

Tips for determining dimensions at the worksite

## Canalis KTA

A

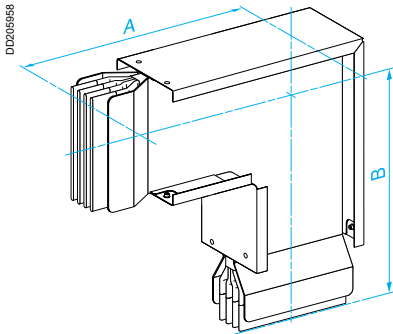

A and B: see "Changes of direction" in "Catalogue numbers and Dimensions".

B

C

D

E

F

G

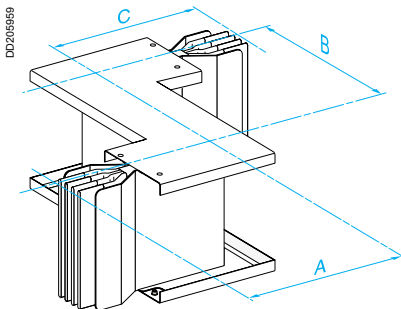

A, B and C: see "Changes of direction" in "Catalogue numbers and Dimensions".

## Edgewise elbows

The nominal length of each branch is measured from the axis of the joint block to the axis of the other branch, in millimetres. The joint block axis is located 20 mm from the end of the bars.

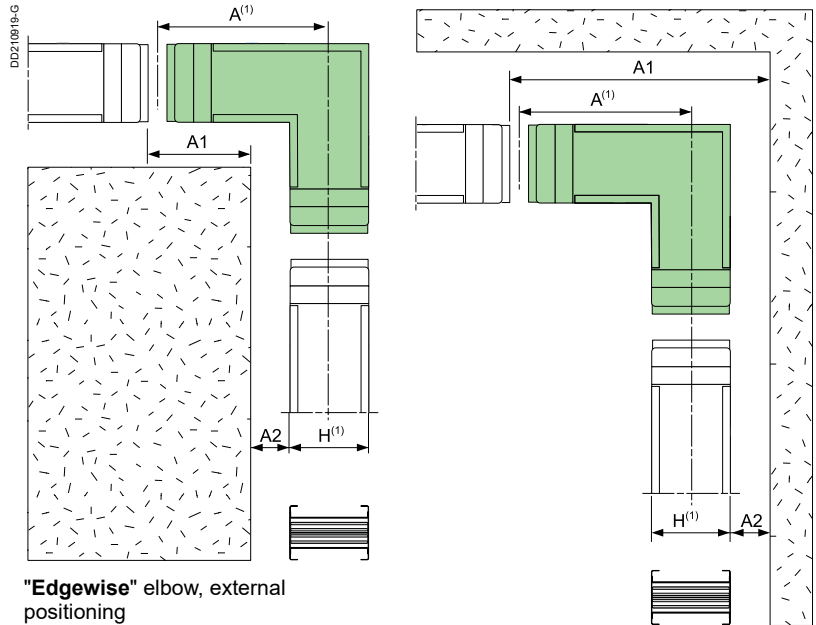

"Edgewise" elbow, external positioning

$$A = A1 + A2 + (H/2) - 20$$

"Edgewise" elbow, internal positioning

$$A = A1 - A2 - (H/2) - 20$$

(1) See "Changes of direction" in "Catalogue numbers and Dimensions".

## Flat Zed

The nominal length of each branch is measured from the axis of the joint block to the axis of the other branch, in millimetres. The joint block axis is located 20 mm from the end of the bars.

The nominal length of the intermediary branch(es) is measured from the axis of one branch to the axis of another.

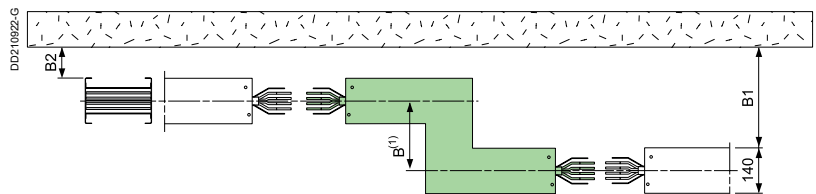

$$B = B1 - B2$$

(1) See "Changes of direction" in "Catalogue numbers and Dimensions".

# Tips for determining dimensions at the worksite

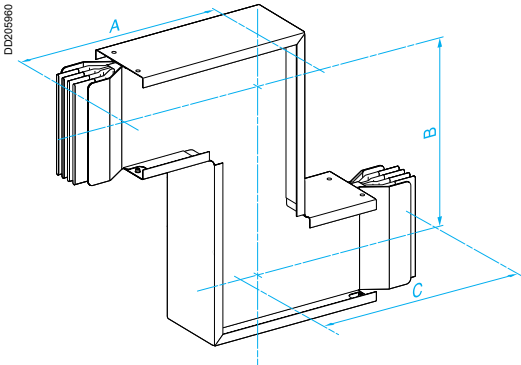

A, B and C: see "Changes of direction" in "Catalogue numbers and Dimensions".

## Edgewise Zed

The nominal length of each branch is measured from the axis of the joint block to the axis of the other branch, in millimetres. The joint block axis is located 20 mm from the end of the bars.

The nominal length of the intermediary branch(es) is measured from the axis of one branch to the axis of another.

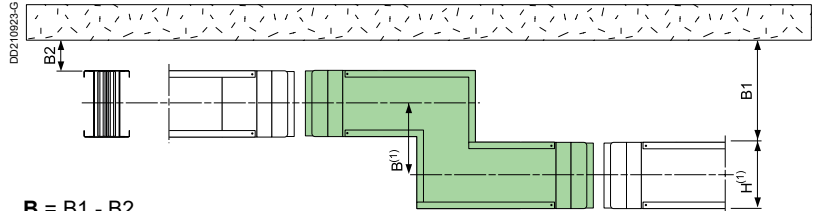

$B = B1 - B2$

(1) See "Changes of direction" in "Catalogue numbers and Dimensions".

## Definition of final section parameters

Reminder: the final section should preferably be a straight section. Take into account the neutral position when choosing the section.

### Tools

Tape measure



Spirit level



Lead line



Stick



Ruler



Laser or infra-red reader



### Their use

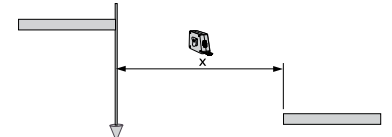
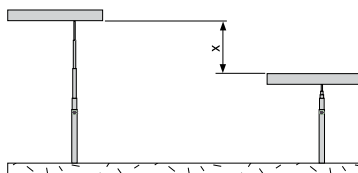
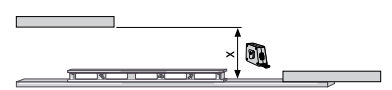
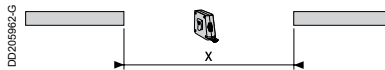

A

B

C

D

E

F

G

# Horizontal distribution

## Positioning the tap-off units

### Canalis KTA

It is possible to combine the following in the same installation:

- straight transport sections with straight sections containing fixed or plug-on tap-off points
- straight sections of different lengths
- straight sections with different numbers of fixed or plug-on tap-off points
- ...



### Positioning the tap-off units on the busbar trunking

Several configurations are possible. Some examples:

- on a 2000 mm straight section with plug-on tap-off points (KTA●●●●ED●20):
- 3 x 160 A circuit breaker tap-off units:

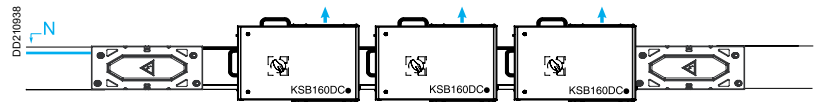

- 1 x 400 A circuit breaker tap-off unit and 1 x 160 A circuit breaker tap-off unit,

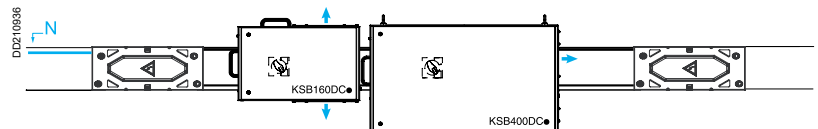

- 3 x 160 A fuse tap-off units:

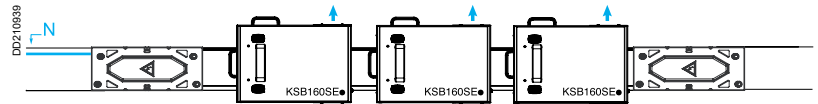

- on a 4000 mm straight section with plug-on tap-off points (KTA●●●●ED●40):
- 1 x 400 A circuit breaker tap-off unit, 1 x 250 A circuit breaker tap-off unit and 1 x 160 A circuit breaker tap-off unit:

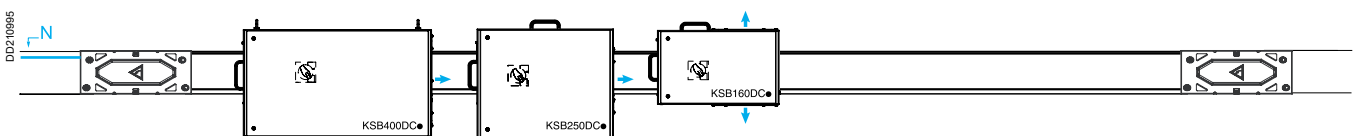

- 1 x 400 A fuse tap-off unit, 1 x 250 A fuse tap-off unit and 1 x 160 A fuse tap-off unit:

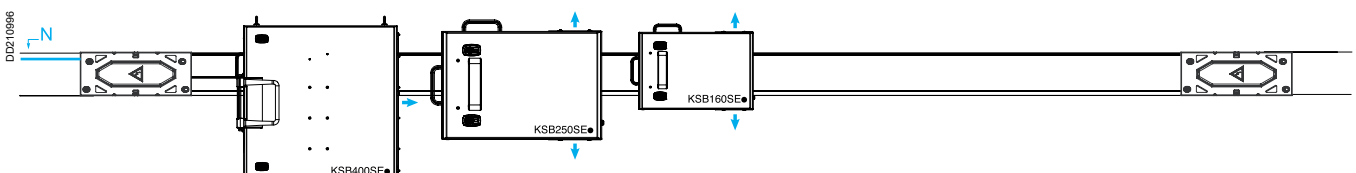

- on a 4000 mm straight section with fixed tap-off points (KTA●●●●EB●40):
- 1 x 400 to 630 A fixed tap-off unit and 1 x 800 to 1000 A fixed tap-off unit:

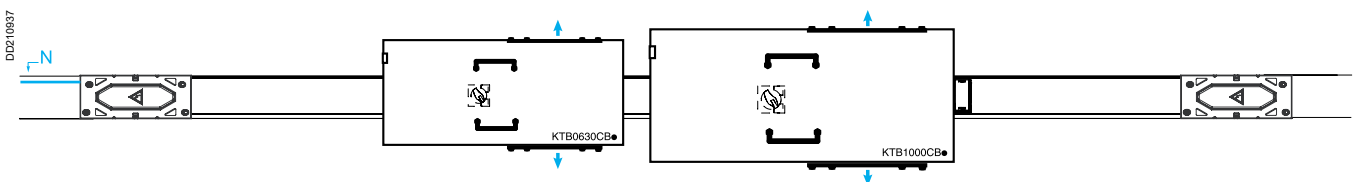

→ Cable exit.

A

B

C

D

E

F

G

# Installation guide

## Horizontal distribution

### Tap-off units

When the tap-off units have to be distributed along the length of the busbar trunking, use 2 metre sections and alternate the tap-off point positions.

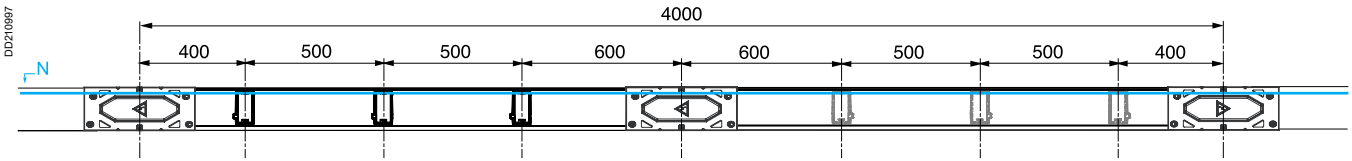

### Recommendations for installing 2 parallel busbar trunking runs

For an installation with tap-off units, provide for a between centres distance that takes into account the minimum dimension of 100 mm and the dimensions A and B of the tap-off units.

Type	Cat. no.	Dimensions (mm)	
		A	B
Circuit breaker tap-off units	KSB160DC●	160	150
	KSB250DC●	240	160
	KSB400DC●	240	160
Fuse tap-off units	KTB0630CB●	175	175
	KTB1000CB●	275	275
	KSB160SE●	150	150
	KSB250SE●	250	160
	KSB400SE●	440	160

### Tap-off unit door opening

Provide for a minimum distance of 1000 mm between the busbar trunking and the ceiling to allow for the opening of tap-off unit doors.

Type	Cat. no.	Dimensions (mm)	
		X	E <sup>(1)</sup>
Circuit breaker tap-off units	KSB160DC●	625.5	246
	KSB250DC●	726.5	300
	KSB400DC●	976.5	350
Fuse tap-off units	KSB160SE●	577.5	207
	KSB250SE●	777	258
	KSB400SE●	855	316

(1) With the handle.

### Installing an isolator or run protective device

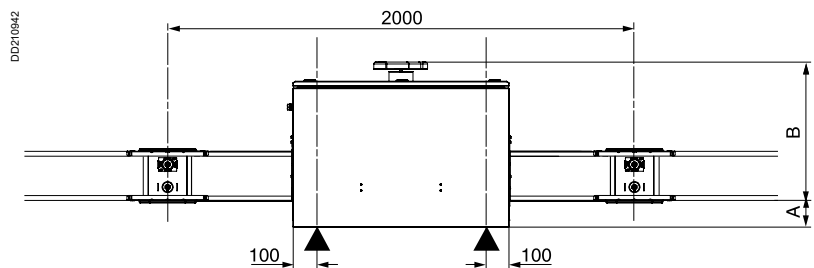

Rating (A)	Dimensions (mm)	
	A	B
1000	159	529
1250	149	539
1600	129	559
2000	109	579
2500	89	599
3200	98	662

# Horizontal distribution

## Checking and compensating for expansion

### Canalis KTA

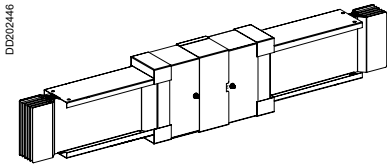

Expansion poses a problem when:

- the runs are made up of long straight sections
- when the busbar trunking passes through an expansion joint between two buildings.

### Long part runs

Electrical busbar trunking can be subjected to a multitude of load variations during its service life (e.g. day/night, summer/winter) which cause temperature rise differences and thus variable expansions.

To absorb expansion in a Canalis KT busbar trunking, a specific section must be used: **the expansion section**.

### Horizontal runs without tap-off units

If the busbar trunking length is greater than 30 metres, provide for expansion sections and appropriate blocking means. The ends and, in some cases, the centre of part runs must be blocked in order to direct the extensions towards the expansion sections.

### Layout of expansion sections and blocking means for the following busbar trunking lengths:

- 0 to 30 metres:



- 31 to 60 metres:

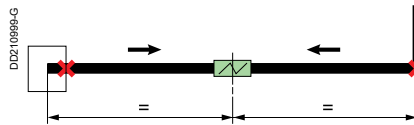

- 61 to 90 metres:

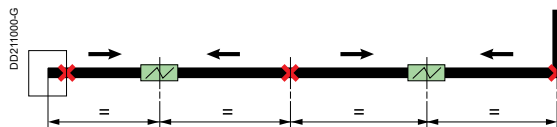

- 91 to 120 metres:

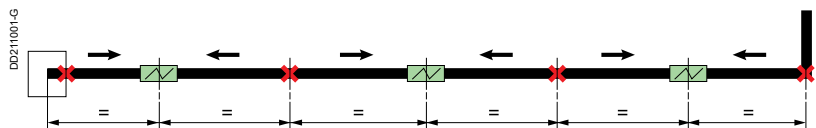

- Blocked fixing supports
- Expansion section
- Direction of expansion

A

B

C

D

E

F

G

# Horizontal distribution

## Checking and compensating for expansion

### Horizontal runs with tap-off units

Layout of expansion sections and blocking means for the following busbar trunking lengths:

■ 0 to 30 metres:

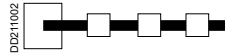

■ 31 to 60 metres:

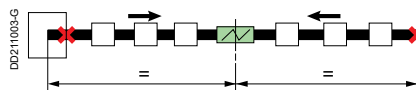

■ 61 to 120 metres:

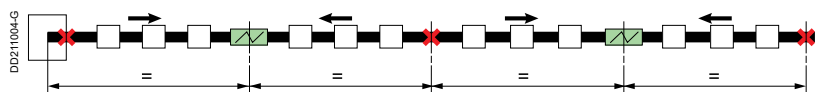

- Blocked fixing supports
- Expansion section
- Direction of expansion
- Tap-off unit

### Transformer/switchboard links

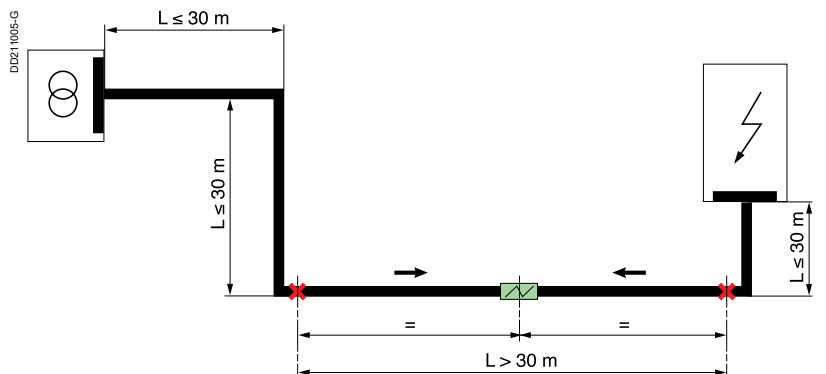

- Blocked fixing supports
- Expansion section
- Direction of expansion



# Horizontal distribution

## Checking and compensating for expansion

### Canalis KTA

A

B

C

D

E

F

G

#### Rules for fixing busbar trunking to the supports

For correct system operation, the expansion of the part run in question must be directed towards the expansion section.

This implies:

- the busbar trunking must be free from all longitudinal movement on its supports
- the expansion section must be blocked on the opposite side to that by which it is pushed.

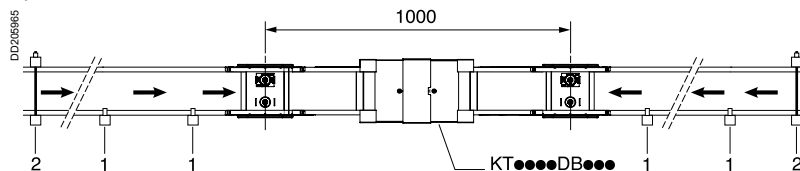

- 1 Free fixings
- 2 Blocked fixings
- Direction of expansion

#### Installation of free fixings

##### Edgewise assembly

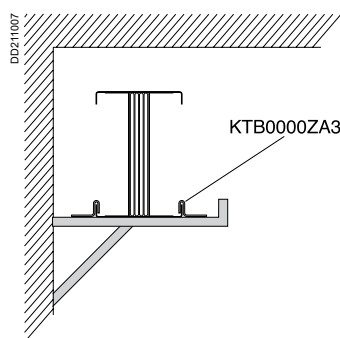

##### Flat assembly

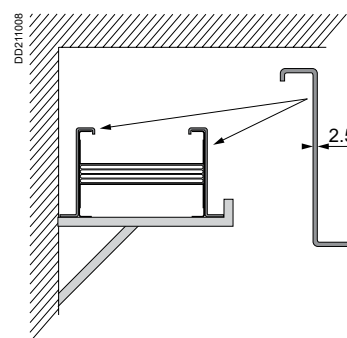

#### Installation of blocked fixings

##### Edgewise assembly

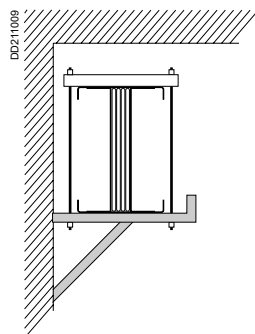

##### Flat assembly

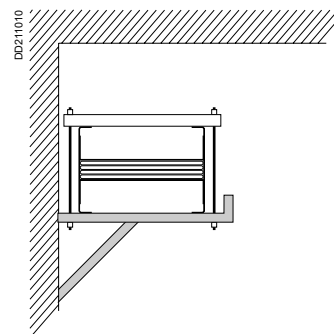

# Installation guide

## Horizontal distribution

### Checking and compensating for expansion

#### Passing through a joint between 2 buildings

Here, the expansion section allows the busbar trunking to absorb the forces due to the relative movement between the 2 buildings.

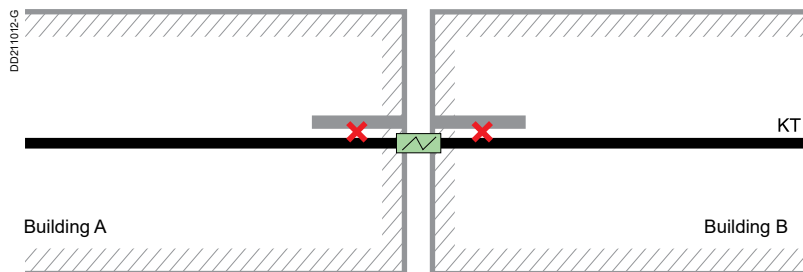

✗ Blocked fixing supports

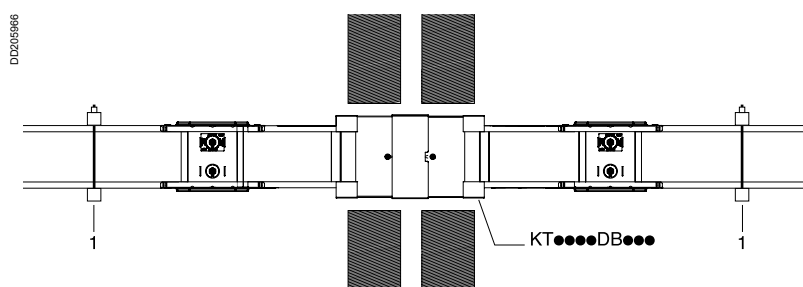

1 Blocked fixings

#### Installation of blocked fixings

##### Edgewise assembly

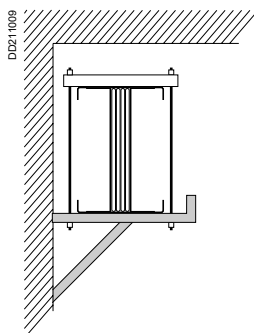

##### Flat assembly

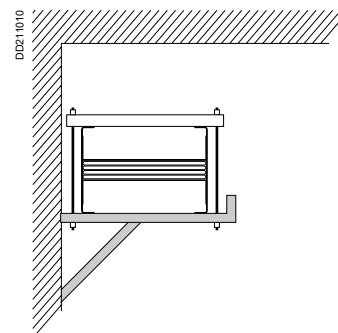

- A
- B
- C
- D
- E
- F
- G

#### Canalis KTA

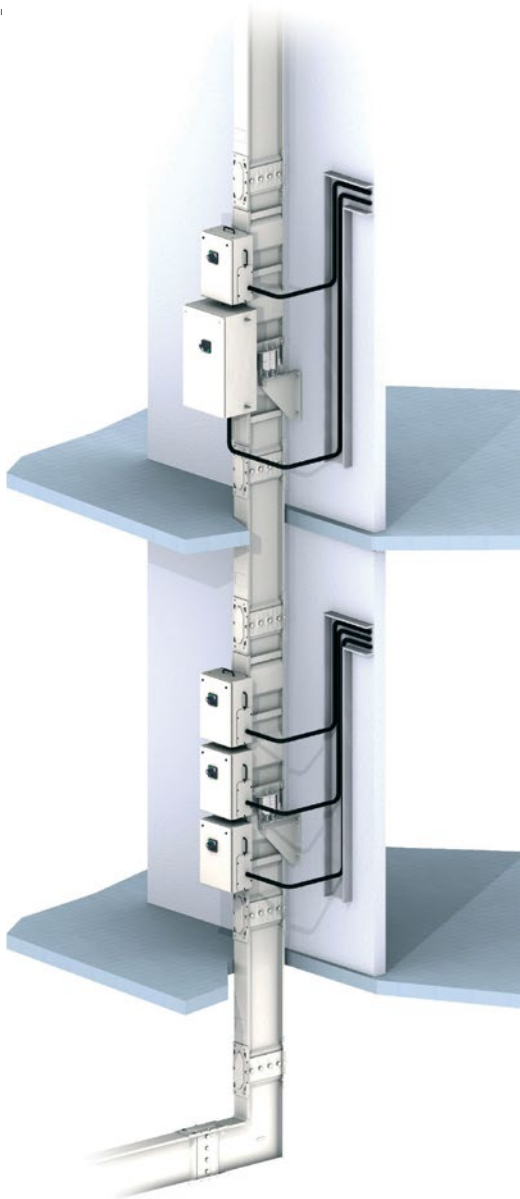

Canalis KT enables power distribution to each floor of multi-storey buildings (office buildings, hotels, hospitals, etc).

In this application, Canalis KT retains all its construction principles:

Vertically mounted, the protection degree of the KT busbar trunking is IP55 as standard.

### Installing a rising main

#### 1 Installation principle

Installation at each floor of:

- a 2 metre distribution section
- a made to measure transport section to go through the floor slab
- a busbar trunking support
- up to 3 x 160 A tap-off units or a 250 or 400 A tap-off unit and a 160 A tap-off unit.

#### 2 Installation feed

The installation feed is achieved using either a cable box or by direct connection to an electrical distribution switchboard.

#### 3 Busbar trunking supports

The supports fix the vertical run section to the building structure. a floor slab support. It can be fixed to either the wall, to a wall bracket or directly to the floor. This type of fixing support has the following advantages:

- fitting to either the wall, to a wall bracket or directly to the floor
- height adjustment to make up for positioning errors
- depth adjustment from 50 to 100 mm
- spring adjustment to ensure distribution of the load at each floor
- absorption of building stresses with respect to the busbar trunking (expansion, vibration, etc) thanks to the springs.

#### 4 Tap-off units

All Canalis KS tap-off units can be mounted vertically on the Canalis KT without the risk of interference with the supports.

# Positioning the busbar trunking without external fire barrier

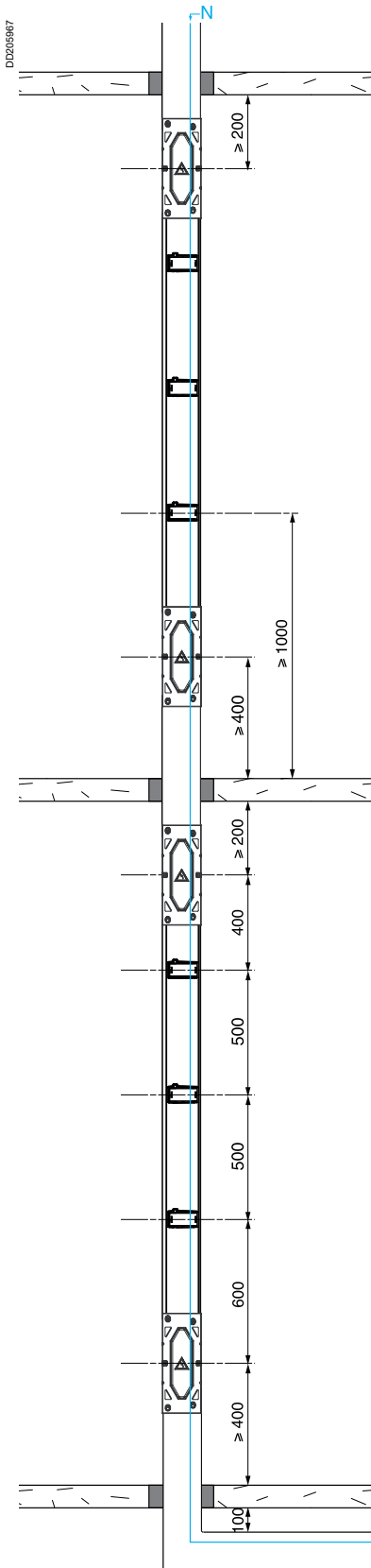

### Positioning the neutral

The busbar trunking must be positioned with the neutral on the right.

### Positioning the joint block

It is important the joint block is not positioned in the floor slab.

We recommend you provide for a distance of:

- 400 mm between the floor slab and the joint block axis to be able to install a support to the wall or wall bracket to facilitate the re-filling of the hole and to cope with possible building faults (e.g. screed not indicated on the drawings). Provide 500 mm for a floor fixing
- 200 mm between the upper joint block and the ceiling to allow the busbar trunking to be boxed-in when filling-in the hole with plaster or concrete.

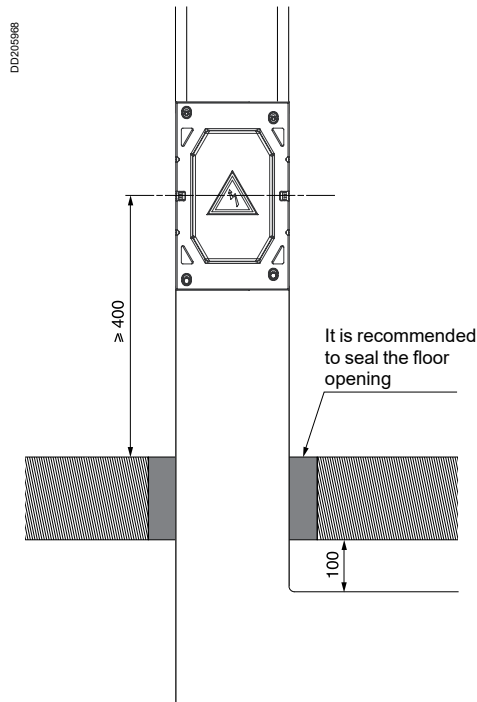

### Positioning the tap-offs

The run sections are fitted with 3 tap-off points. Spaced at 500 mm intervals, they provide a high density of tap-offs per floor.

#### Edgewise passage through partition wall

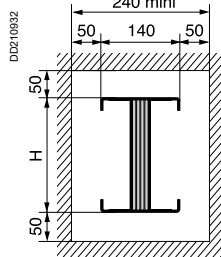

#### Flat passage through partition wall

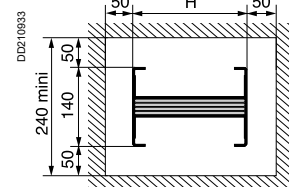

Rating (A)	800	1000	1250	1600	2000	2500	3200	4000
Height H (mm)	74	104	124	164	204	244	324	404



# Installation guide

## Rising mains

### Positioning the tap-off units

#### Canalis KTA

- A
- B
- C
- D
- E
- F
- G

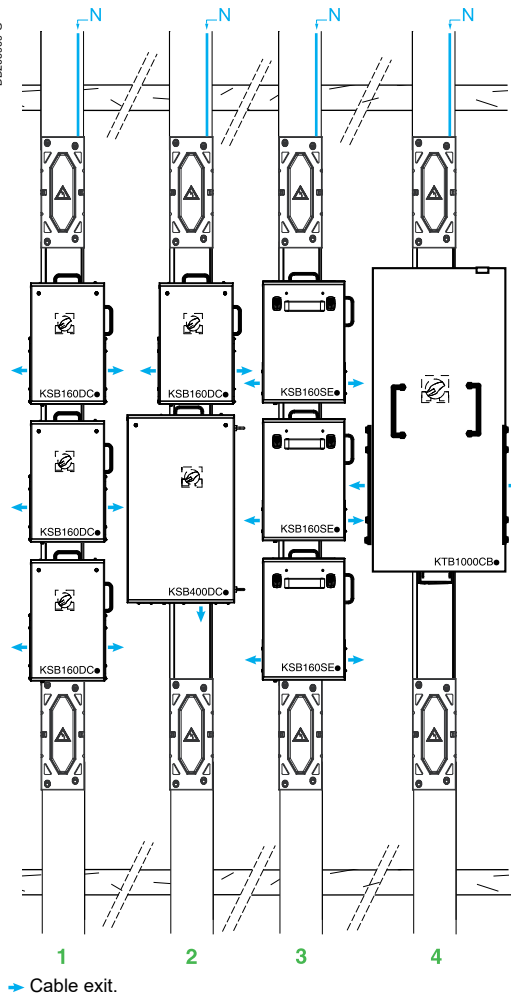

#### Positioning the tap-off units on the busbar trunking

Several configurations are possible.

Some examples:

- 1 - 3 x 160 A circuit breaker tap-off units
- 2 - 1 x 400 A circuit breaker tap-off unit and 1 x 160 A circuit breaker tap-off unit
- 3 - 3 x 160 A fuse tap-off units
- 4 - 1 x 800 to 1000 A bolted tap-off unit

#### Cable exit

R = 12 x Ø of cable

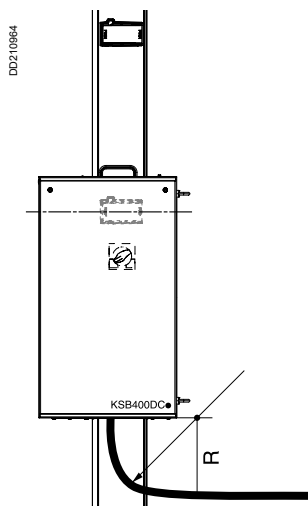

#### Recommendations for installing 2 rising mains in parallel

For an installation with tap-off units, provide for a between centres distance that takes into account the minimum dimension of 100 mm and the dimensions A and B of the tap-off units.

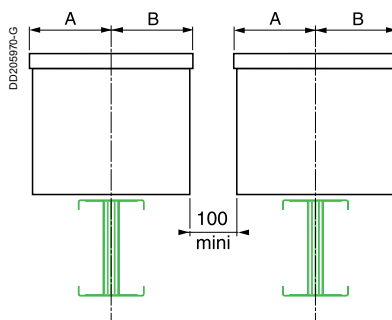

Type	Cat. no	Dimensions (mm)	
		A	B
Circuit breaker tap-off units	KSB160DC●	160	150
	KSB250DC●	240	160
	KSB400DC●	240	160
	KTB0630CB●	175	175
	KTB1000CB●	275	275
Fuse tap-off units	KTB0630DC●	275	275
	KSB160SE●	150	150
	KSB250SE●	250	160
	KSB400SE●	440	160
	KTB0630SD●	275	275

#### Tap-off unit door opening

If installed in a technical room, provide for a minimum distance of 1000 mm between the busbar trunking and the wall in order to be able to open the doors of the tap-off units.

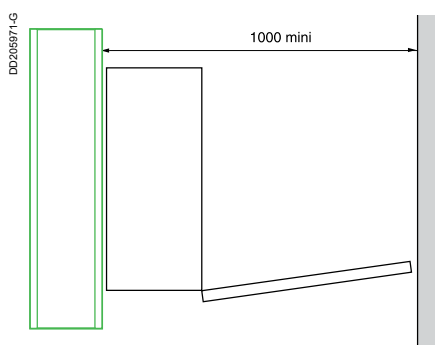

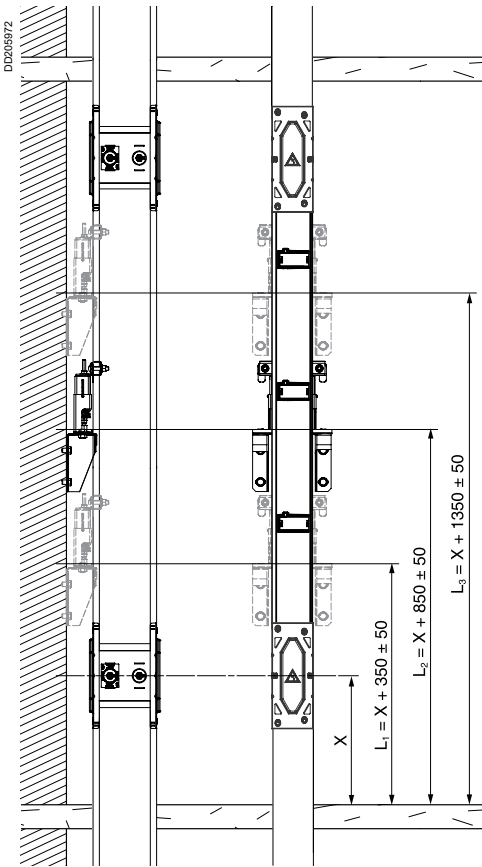

$X \geq 400$ .

Spring hangers vertical supports KTB...ZA5 are designed for buildings with an average gap between floors of 3 to 4 meters between each floor.  
 - If these distance is punctually reduced or increased (Max 5 meters with no more than 1 element without support in between) additional supports should then be added to fit a good column consistency. The average distance between supports should stay between 3 to 4 meters.  
 - Also, a distribution element with high rating tap offs (630 A and more) should have a spring hanger on its length.

2 fixing systems are available:  
 ■ a rear wall fixing system for 800 A to 1600 A busbar trunking  
 ■ a side wall fixing system for 2000 A to 4000 A busbar trunking.

### Wall support

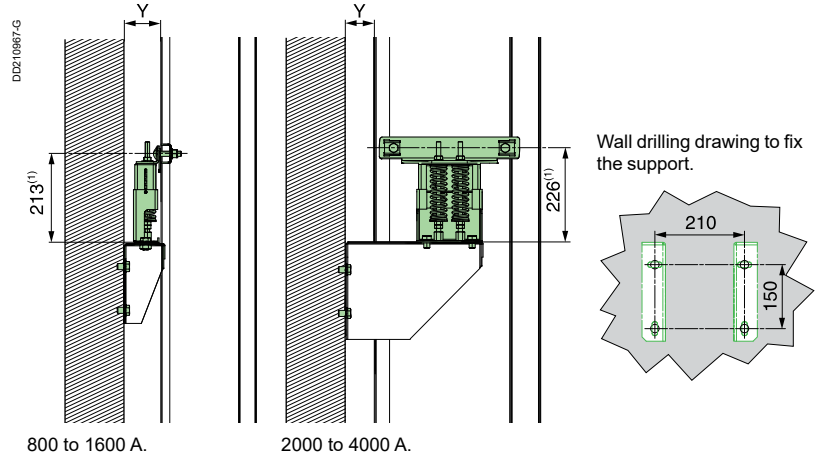

800 to 1600 A.

2000 to 4000 A.

(1) Dimensions with free springs.  
 Y: 50 mm minimum to 100 mm maximum

### Wall bracket support (if $Y > 100$ mm)

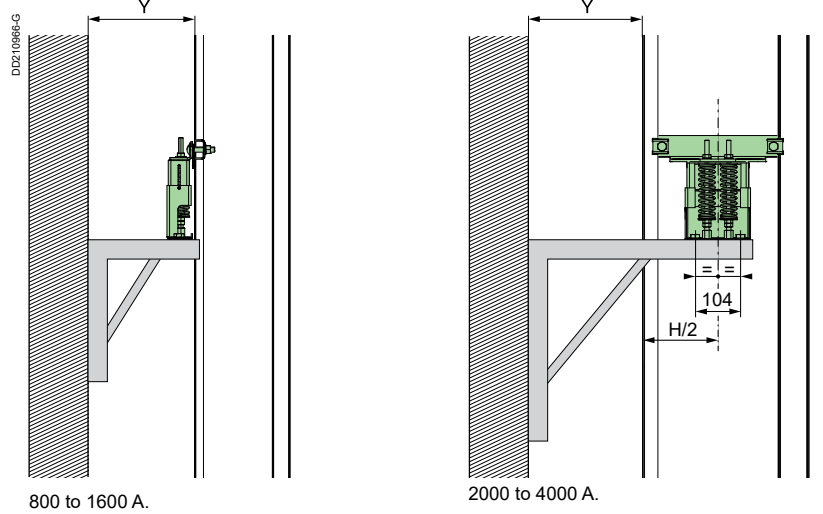

800 to 1600 A.

2000 to 4000 A.

Rating (A)	2500	3200	4000	5000
Height H (mm)	204	244	324	404

### Floor support

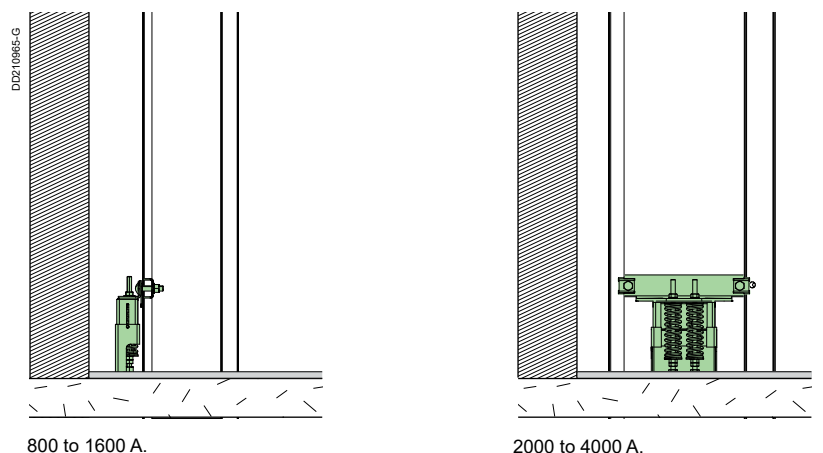

800 to 1600 A.

2000 to 4000 A.



# Installation guide

## Rising mains

### Positioning the external fire barriers

#### Canalis KTA

The filler material around the busbar trunking must meet the requirements currently in force to guarantee that the wall and ceiling fire-resistance class (for example DIN 1045 and DIN 1053-1) is maintained. Filler material not supplied.

A

B

C

D

E

F

G

Vertical mounting

Horizontal mounting

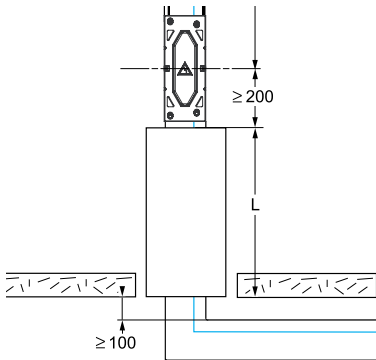
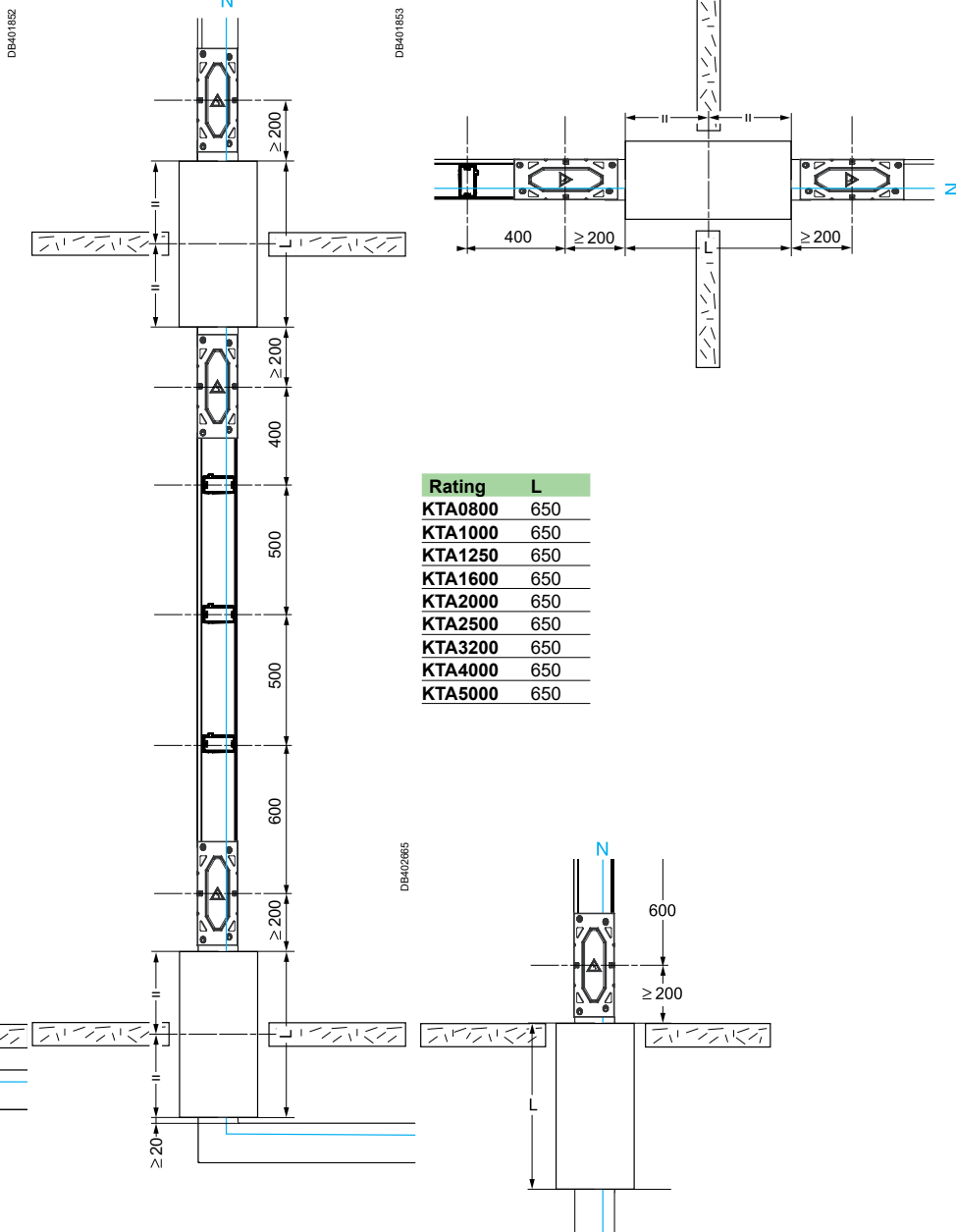

Edgewise passage through partition wall

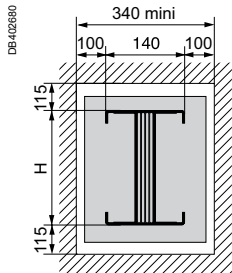

Flat passage through partition wall

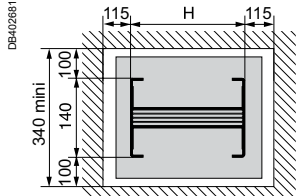

Distances to comply

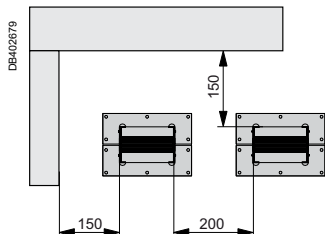
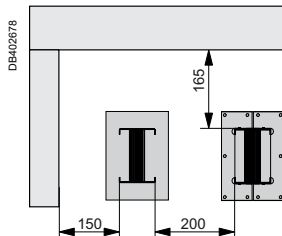

### Installation with feed via a cable box or direct onto the switchboard

2 possibilities:

- installation with feed direct to the switchboard
- installation with feed via a cable box.

#### Installation with feed via a cable box.

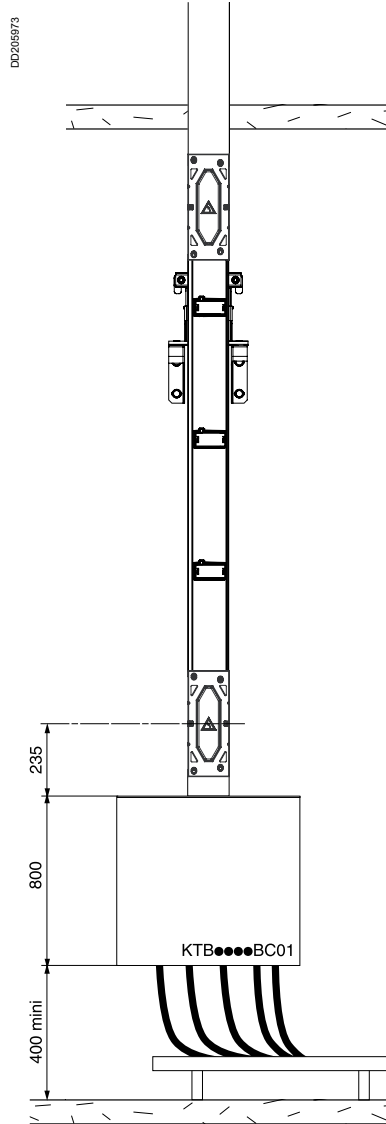

A

B

C

D

E

F

G

# Installation guide

## Rising mains

Installation with feed via a cable box or direct onto the switchboard

### Canalis KTA

Installation with feed direct to the switchboard

A

B

C

D

E

F

G

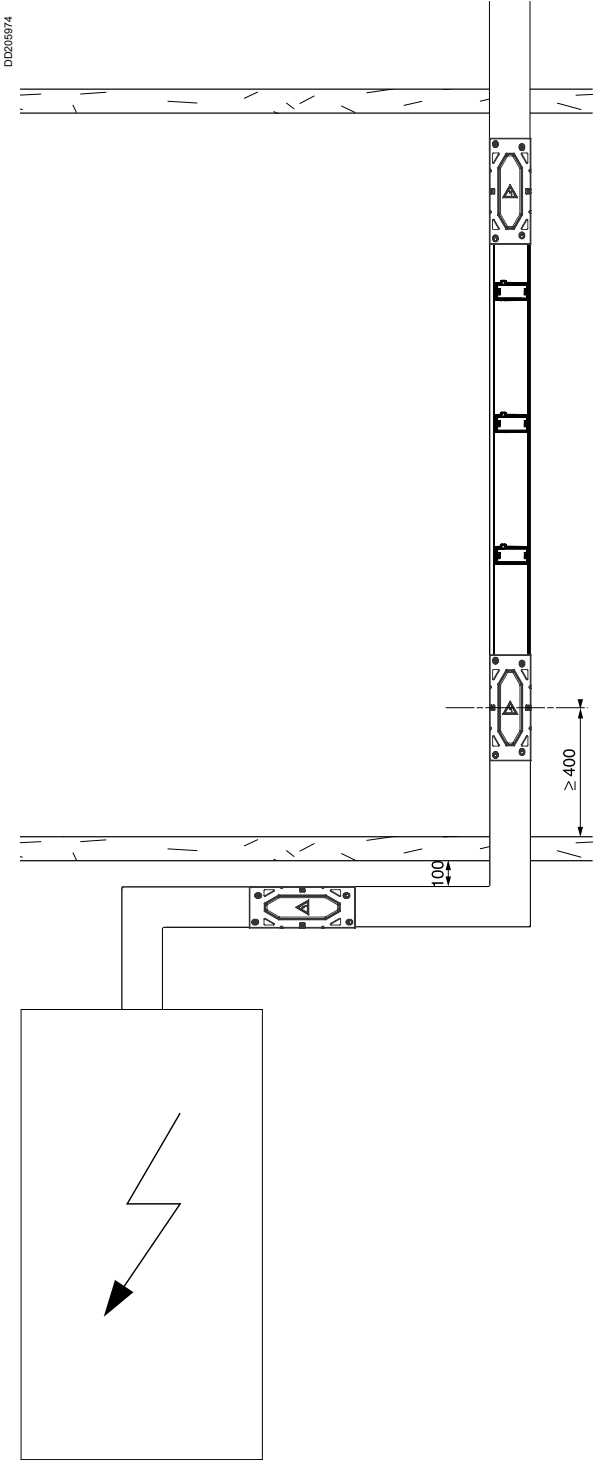

A

B

C

D

E

F

G

### Canalis KTA

#### The Schneider Electric system

The comprehensive Schneider Electric system makes it simple to design a complete transformer/Canalis KT/switchboard installation. Using dedicated interfaces, the trunking connects directly to the dry-type transformer and the switchboard for:

- tested and standardised connections
- fast and flexible installation
- shorter lead times.

#### Advantages

- No design work for the connections.
- Simplified layout design:
  - pre-defined position of the jointing unit
  - simplified routing (only three dimensions required)
  - smaller size (no additional covers required).
- Transformer and switchboard supplied with connections already mounted.
- Short lead times and fewer catalogue numbers for connections.
- Adaptable on the worksite:
  - transformer end: ±15 mm adjustments along all three axes
  - switchboard end: phases can be inverted.
- Continuity of service:
  - transformer can be replaced in less than one hour
  - transformer, trunking and switchboard designed to be used together.
- Safety:
  - trunking fully tested in compliance with IEC 61439-1 and 61439-6
  - compliance with standards and installation rules
  - excellent fire-withstand capability.
- Comfort:
  - low level of electromagnetic radiation
  - no noise.

#### Compatibility between Trihal transformers/Canalis KT/PrismaSeT or Okken switchboards

Trihal transformers					PrismaSeT or Okken switchboards							
Rating	Naturally ventilated (AN) dry-type transformers le max.	Forced ventilated (AF) dry-type transformers, 25% overload accepted le max.	Interfaces		NS-MTZ1/NT-MTZ2/NW circuit breakers				NS-MTZ2/NW circuit breakers			MTZ2/NW circuit breakers
				Junctions	800 A	1000 A	1250 A	1600 A	2000 A	2500 A	3200 A	4000 A
					08/16				20/25	32	40	
					H164				H244	H404	H404	
630 kVA	887 A	1109 A	n°1	H124	KTA1000, KTA1250	KTA1000, KTA1250	KTA1000, KTA1250	KTA1000, KTA1250	-	-	-	-
800 kVA	1126 A	1408 A	n°2	H164	KTA1250, KTA1600	KTA1250, KTA1600	KTA1250, KTA1600	KTA1250, KTA1600	KTA1600	KTA1600	-	-
1000 kVA	1408 A	1760 A	n°3	H204	KTA1600	KTA1600	KTA1600	KTA1600	KTA1600, KTA2000	KTA1600, KTA2000	-	-
1250 kVA	1760 A	2200 A	n°4	H244	-	-	-	-	KTA2000, KTA2500	KTA2000, KTA2500	-	-
1600 kVA	2253 A	2816 A	n°5	H324	-	-	-	-	KTA2500	KTA2500	KTA3200	KTA3200
2000 kVA	2813 A	3516 A	n°6	H404	-	-	-	-	-	-	KTA3200, KTA4000	KTA3200, KTA4000
2500 kVA	3520 A	4400 A	n°7	H404	-	-	-	-	-	-	KTA4000	KTA4000

(1) The compatibilities indicated correspond to the electrical connection possibilities; in all cases, coordination between circuit breaker and electrical busbar trunking must be checked.

Connection to a dry-type transformer using a dedicated interface, see page 228.

Connection to an LV switchboard using a dedicated interface, see page 214.

PB125377

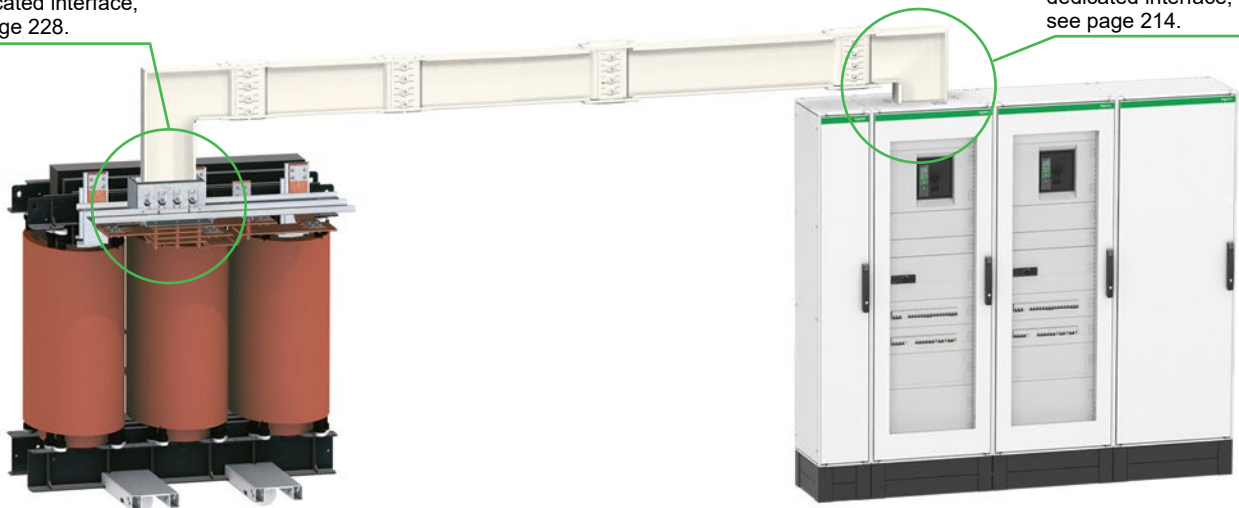

# Installation guide Panorama of connection solutions

Universal connection to a dry-type transformer, see page 231.

Connection to an LV switchboard using a dedicated interface, see page 214.



Universal connection to an oil-filled transformer, see page 240.

Universal connection to an LV switchboard, see page 220.



- A
- B
- C
- D
- E**
- F
- G

# Connection to LV switchboards

## Selection guide

### Canalis KTA

This guide may be used to:

- select the connection best suited to your installation (incoming direction, trunking installed flat or edgewise, different phase order)
- check the total height of the connection with respect to the ceiling, i.e. dimension  $Z_0 + Z_2$  (100 mm minimum clearance required between top of connection and ceiling)
- optimise the connection by ensuring that  $(Z_0 + Z_1)_{\text{switchboard}} = (Z_0 + Z_1)_{\text{transformer}}$  to avoid having to use elbows and zed units
- position the fixing devices used to support the trunking.

Type of connection	Connection with an interface		Direct connection
	SB1	SB2	Without protective covers SB3
$Z_0$	see page 214	see page 214	As per manufacturing drawings
$Z_1$ minimum	74	82	138
maximum	-	-	472
$Z_2$	$Z_1 + 140$	$Z_1 + H$	$Z_1 + H$
Phase order can be changed	■	■	
Mounting in workshop	■	■	
Exit through front or rear	■		■
Exit through left or right side		■	
Edgewise installation		■	■
Flat installation	■		



#### Trunking cross-section

Rating (A)	800 <sup>(1)</sup>	1000	1250	1600	2000	2500	3200	4000	5000
Height H (mm) Width W (mm)									

(1) Important: for the 800 A rating, indicate "KTA0800".

SB4	SB5	SB6	With protective covers SB7						
As per manufacturing drawings	As per manufacturing drawings	As per manufacturing drawings	As per manufacturing drawings						
473	130	465	<table border="1"> <tr> <td>H = 74 to 124 mm</td> <td>195 - H/2</td> </tr> <tr> <td>H = 164 to 244 mm</td> <td>255 - H/2</td> </tr> <tr> <td>H = 324 to 404 mm</td> <td>355 - H/2</td> </tr> </table>	H = 74 to 124 mm	195 - H/2	H = 164 to 244 mm	255 - H/2	H = 324 to 404 mm	355 - H/2
H = 74 to 124 mm	195 - H/2								
H = 164 to 244 mm	255 - H/2								
H = 324 to 404 mm	355 - H/2								
-	464	-	-						
$Z_1 + H$	$Z_1 + 140$	$Z_1 + 140$	<table border="1"> <tr> <td>H = 74 or 104 or 124 mm</td> <td><math>Z_1 + H/2 + 115</math></td> </tr> <tr> <td>H = 164 or 204 or 244 mm</td> <td><math>Z_1 + H/2 + 175</math></td> </tr> <tr> <td>H = 324 or 404 mm</td> <td><math>Z_1 + H/2 + 255</math></td> </tr> </table>	H = 74 or 104 or 124 mm	$Z_1 + H/2 + 115$	H = 164 or 204 or 244 mm	$Z_1 + H/2 + 175$	H = 324 or 404 mm	$Z_1 + H/2 + 255$
H = 74 or 104 or 124 mm	$Z_1 + H/2 + 115$								
H = 164 or 204 or 244 mm	$Z_1 + H/2 + 175$								
H = 324 or 404 mm	$Z_1 + H/2 + 255$								
■		■	■						
■	■	■	■						
■	■	■	■						

## Installation guide

# Connection to LV switchboards By Canalis interface

### Canalis KTA



Switchboards can be equipped with connections for Canalis KT. Joining with the switchboard is via a standard run component (straight length, elbow, etc.) and a jointing unit (identical to those used between line components). The trunking enters the switchboard via the top (roof).

Switchboard connections are available from 800 to 4000 A.

Type of switchboard	Rating of trunking (A)	Type of circuit breaker	Type of connection
PrismaSeT	800 to 1600	Compact NS	Top direct and rear
		Masterpact MTZ1/NT	Top direct and rear
	800 to 3200	Masterpact MTZ2/NW	Top direct and rear
	4000	Masterpact MTZ2/NW	Rear
Okken	800 to 4000	Masterpact MTZ2/NW	Top direct and rear
	5000	Masterpact MTZ3/NW40b-50	Rear

**Connections are tested and qualified under normal operating conditions in terms of temperature rise ( $\Delta\theta$ ) and short-circuit currents (Isc).**

The panel builder receives and connects the Canalis KT interface in the workshop. The phase order at the interface output can be adapted if necessary (this information must be forwarded to the panel builder).

The switchboard is then delivered to the site and the trunking can be rapidly connected using a simple jointing unit with torque nuts to ensure the correct tightening torque.

### Compatibility between Canalis KT and the interface in the switchboard<sup>(1)(2)</sup>

Canalis KT				Circuit breakers in Okken and PrismaSeT switchboards								
Cat. no.	Rating (A)	Height (mm)	Sealing kit	NS - MTZ1/NT - MTZ2/NW			NS - MTZ2/NW			MTZ2/NW	MTZ3/NW	
				800 and 1000 A	1250 A	1600 A	2000 A	2500 A	3200 A	4000 A	5000 A	
				Interface 08/16			Interface 20/25			Interface 32	Interface 40	Interface 40b-63
				H164 <sup>(3)</sup>			H244 <sup>(3)</sup>			H404 <sup>(3)</sup>	H404 <sup>(3)</sup>	H622 <sup>(3)(4)</sup>
<b>KTA1000</b>	1000	104	KTB0104TT01									
<b>KTA1250</b>	1250	124	KTB0124TT01									
<b>KTA1600</b>	1600	164	KTB0164TT01									
<b>KTA2000</b>	2000	204	KTB0204TT01									
<b>KTA2500</b>	2500	244	KTB0244TT01									
<b>KTA3200</b>	3200	324	KTB0324TT01									
<b>KTA4000</b>	4000	404	KTB0404TT01									
<b>KTA5000</b>	5000	622	KTB0622TT01									

(1) The compatibilities indicated correspond to the electrical connection possibilities; in all cases, coordination between circuit breaker and electrical busbar trunking must be checked.

(2) Coordination with a dry-type transformer, see the "Transformer" section, page 228.

(3) Height of the jointing unit in millimetres.

(4) Connection only to Okken interface.

The prefabricated connections installed in the switchboard are designed to operate without derating and can therefore operate at the rated circuit breaker current.

### Phase order

Using the dedicated interface, it is possible to change the phase order if it is different between the trunking and the switchboard.

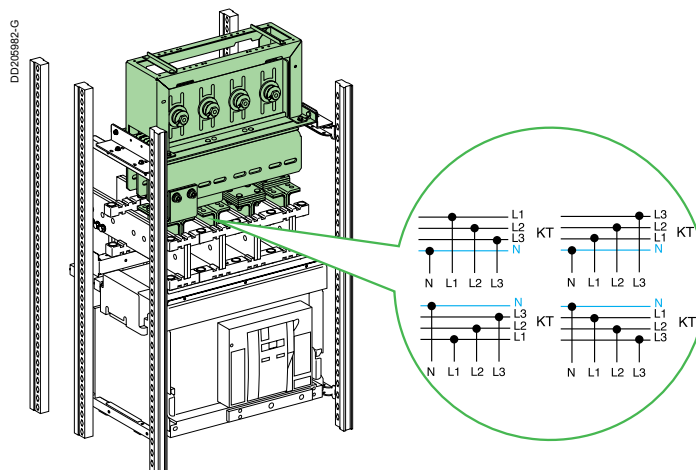

# Installation guide

## Connection to LV switchboards

### By Canalis interface

### Connection to Okken switchboards

### Top direct connection (TDC)

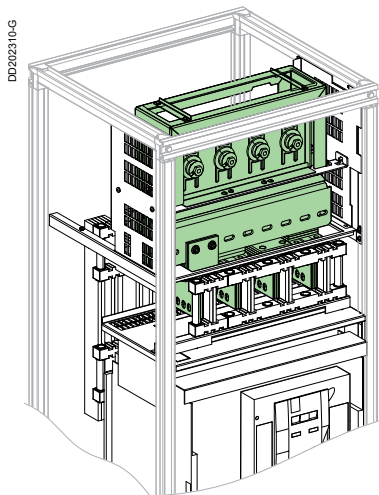

#### To 800 to 4000 A Masterpact MT22/NW circuit breakers

- Enclosure 600 or 1000 mm deep, access through the front.

#### Position of the jointing unit

Circuit breaker	Dimensions (mm)		
	A	B	C
Drawout, 3P/4P <sup>(1)</sup>			
MT22/NW 08/16	175	325	156
MT22/NW 20/25	175	325	156
MT22/NW 32	175	325	156
MT22/NW 40	175	325	156

(1) To order, see "Catalogue numbers", page 77.

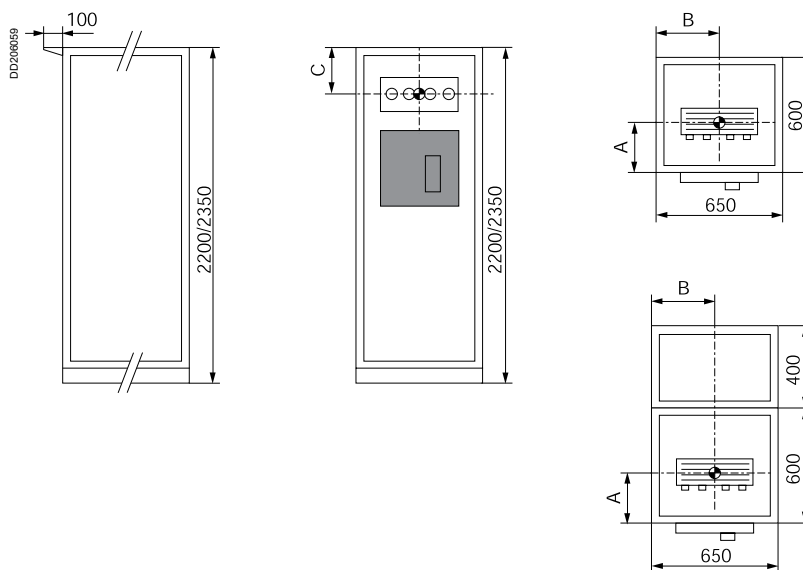

⊕ Reference point



# Connection to LV switchboards

## By Canalis interface

### Connection to Okken switchboards

#### Canalis KTA

#### Rear connection (RC)

- A
- B
- C
- D
- E
- F
- G

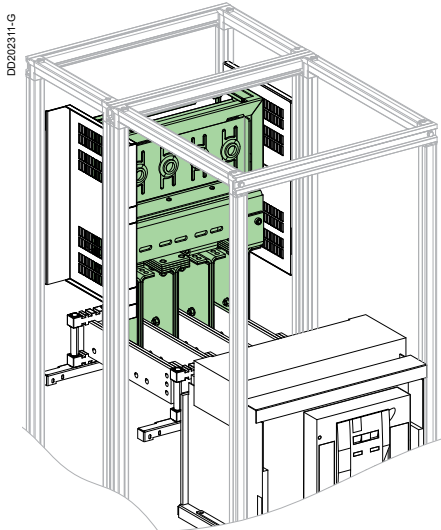

**To 800 to 5000 A Masterpact MTZ2/NW circuit breakers**  
 ■ Enclosure 1000, 1200 or 1400 mm deep, access through the rear.

#### Position of the jointing unit

Circuit breaker	Dimensions (mm)							
	A			B		C		
	Depth (mm)			Width (mm)		Height (mm)		
	1000	1200	1400	650	1150	2350	2200	
Drawout, 3P/4P <sup>(1)</sup> , top position	MTZ2/NW 08/16	825	-	-	363	-	317	-
	MTZ2/NW 20/25	825	-	-	363	-	317	-
	MTZ2/NW 32	825	-	-	363	-	317	-
	MTZ2 (3/4P)/ NW40 (3P)	-	953	1196	363	-	156	-
	NW40 (4P)	-	953	1196	363	-	381	-
	MTZ3 NW40b (SHBB only)	800	1033	1200	-	575	174	174
Drawout, 3P/4P <sup>(1)</sup> , medium position	MTZ2/NW 08/16	825	-	-	363	-	942	-
	MTZ2/NW 20/25	825	-	-	363	-	942	-
	MTZ2/NW 32	825	-	-	363	-	942	-
	MTZ2 (3/4P)/ NW40 (3P)	-	953	1196	363	-	881	-
Drawout, 3P/4P <sup>(1)</sup> , bottom position	NW40 (4P)	-	953	1196	363	-	1008	-
	115-3 NW40	-	953	1196	363	-	881	-
	115-4 NW40	-	953	1196	363	-	1006	-
	MTZ2/NW 08/16	-	-	1225	363	-	1417	-
	MTZ2/NW 20/25	-	-	1225	363	-	1417	-
	MTZ2/NW 32	-	-	1225	363	-	1417	-
MTZ3 NW40b	800	964	1200	-	575	2065	1913	
MTZ3 NW50	800	964	1200	-	575	2068	1915	

(1) To order, see "Catalogue numbers", page 77.

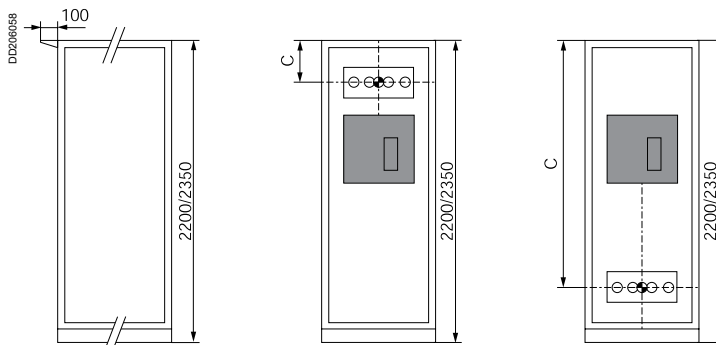

Top views  
Depth: 1000 mm

Top connection

Depth: 1200 mm

Bottom connection

Depth: 1400 mm

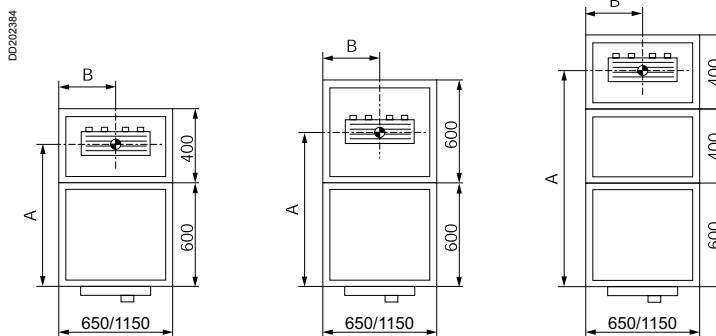

☉ Reference point

#### Bottom connection

For installations with connections through the bottom, please consult us.

# Connection to LV switchboards

By Canalis interface

Connection to PrismaSeT switchboards

## Top direct connection (TDC)

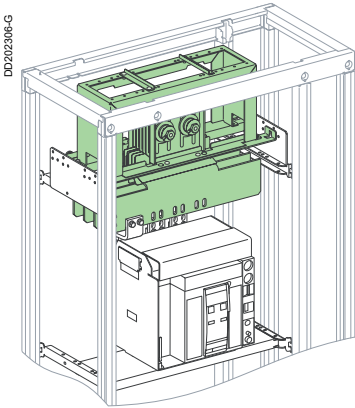

**To a Compact NS1250 or Masterpact MTZ1/NT 1600 circuit breakers**  
 ■ Enclosure 400 mm deep, access through the front.

### Position of the jointing unit

Circuit breaker		Dimensions <sup>(1)</sup> (mm)		
		A	B	C
Fixed, 3P/4P <sup>(2)</sup>	NS800/1250	260	325	173
	MTZ1/NT 06/16	260	325	173
Drawout, 3P/4P <sup>(2)</sup>	NS800/1250	260	325	198
	or 06/MTZ1/NT 16			

(1) Dimensions measured from switchboard framework.  
 (2) To order, see "Catalogue numbers", page 75.

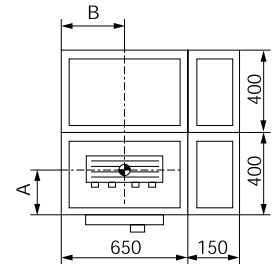
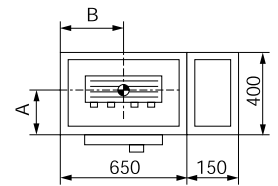
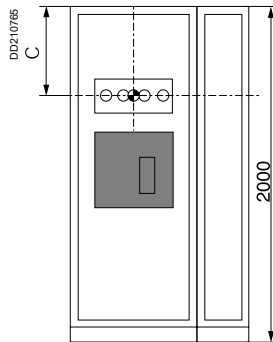

Reference point

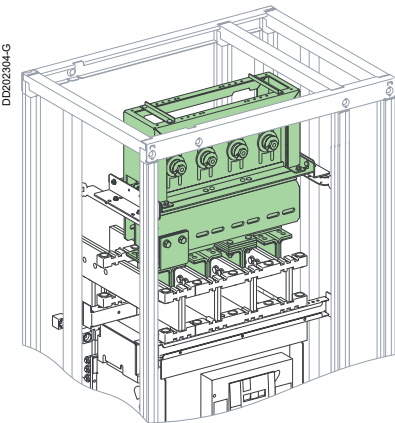

**To 800 to 5000 A Masterpact MTZ2/MTZ3/NW circuit breakers**  
 ■ Enclosure 600 mm deep, access through the front.

### Position of the jointing unit

Circuit breaker		Dimensions <sup>(1)</sup> (mm)		
		A	B	C
Fixed, 3P/4P <sup>(2)</sup>	MTZ2/NW 08/16	185	325	254
	MTZ2/NW 20/25	185	325	304
	MTZ2/NW 32	185	325	279
Drawout, 3P/4P <sup>(2)</sup>	MTZ2/NW 08/16	185	343	179
	MTZ2/NW 20/25	185	343	196
	MTZ2/NW 32	185	343	214
	MTZ3/NW40b-63 A	555	600	174

(1) Dimensions measured from switchboard framework.  
 (2) To order, see "Catalogue numbers", page 74.

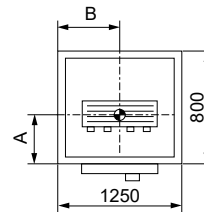
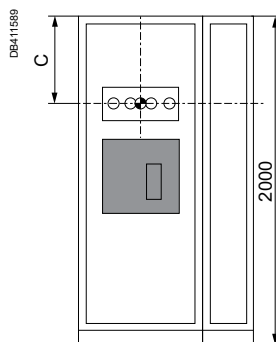

For MTZ3/NW40b-63

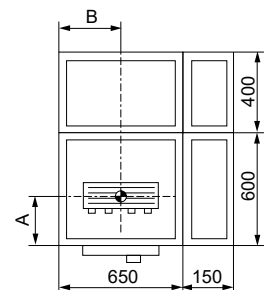
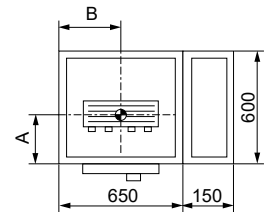

Reference point



## Installation guide

## Connection to LV switchboards

## By Canalis interface

## Connection to PrismaSeT switchboards

## Canalis KTA

## Rear connection (RC)

A

B

C

D

E

F

G

DD202307-G

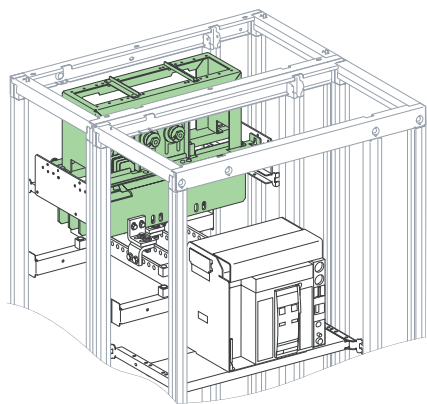

## To a Compact NS1600 or Masterpact MTZ1/NT 1600 circuit breakers

- Two enclosures combined:
- 1 enclosure, 400 mm deep, for the circuit breaker
- 1 enclosure, 400 mm deep, for the Canalis KT/switchboard interface.

## Position of the jointing unit

Circuit breaker		Dimensions <sup>(1)</sup> (mm)		
		A	B	C
Fixed, 3P/4P <sup>(2)</sup>	NS800/1600 or MTZ1/NT 06/16	638	325	219
Drawout, 3P/4P <sup>(2)</sup>	NS800/1600 or MTZ1/NT 06/16	638	325	269

(1) Dimensions measured from switchboard framework.

(2) To order, see "Catalogue numbers", page 75.

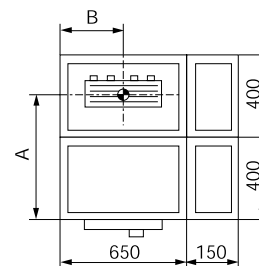
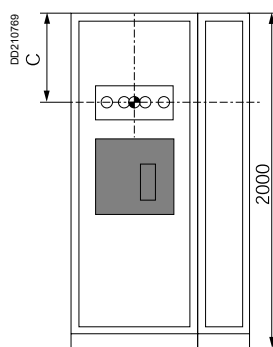

Reference point

## To 800 to 4000 A Masterpact MTZ2/NW circuit breakers

- Two enclosures combined:
- 1 enclosure, 600 mm deep, for the circuit breaker
- 1 enclosure, 400 mm deep, for the Canalis KT/switchboard interface.

## Position of the jointing unit

Circuit breaker		Dimensions <sup>(1)</sup> (mm)		
		A	B	C
Fixed, 3P/4P <sup>(2)</sup>	MTZ2/NW 08/16	815	325	279
	MTZ2/NW 20/25	815	325	279
	MTZ2/NW 32	815	325	279
	MTZ2/NW 40	790	325	422
Drawout, 3P/4P <sup>(2)</sup>	MTZ2/NW 08/16	815	307	279
	MTZ2/NW 20/25	815	307	279
	MTZ2/NW 32	815	307	239
	MTZ2/NW 40	790	325	422

(1) Dimensions measured from switchboard framework.

(2) To order, see "Catalogue numbers", page 74.

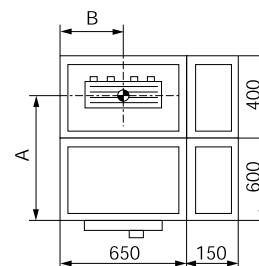
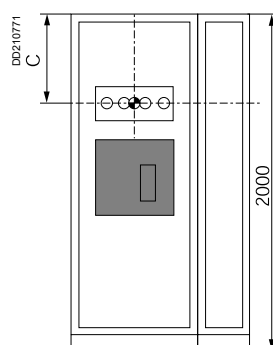

Reference point

# Connection to LV switchboards

By Canalis interface

Connection to Okken and PrismaSeT switchboards

## Sealing kit

The sealing kit must be ordered with the KT trunking. The size of the trunking determines that of the sealing kit. For the different types of kit, see the "Catalogue numbers and dimensions" pages. The kit includes a drilling and cut-out drawing for the switchboard roof.

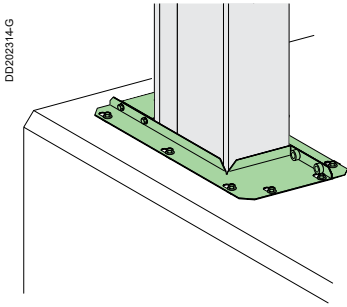

KTB0●●●●TT01

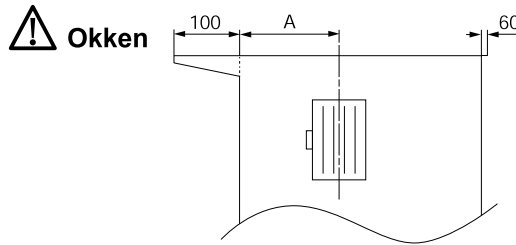
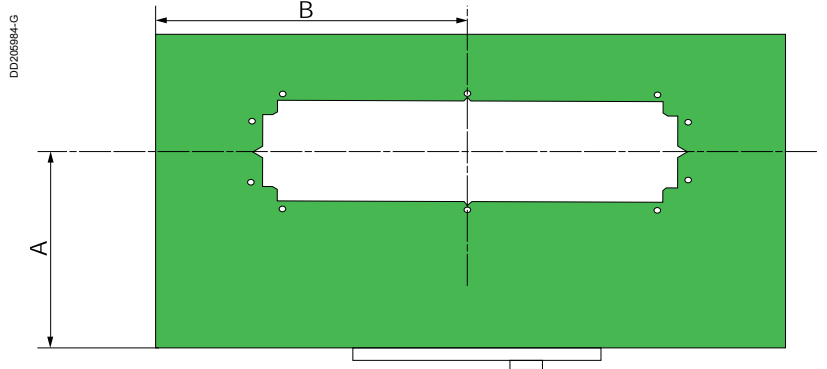
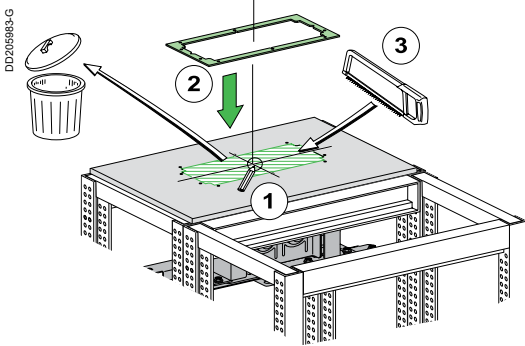

## Cut-out drawing (for all the ratings)

It is advised to cut out the switchboard roof in the workshop. **Important:** the dimensions are measured from switchboard framework.

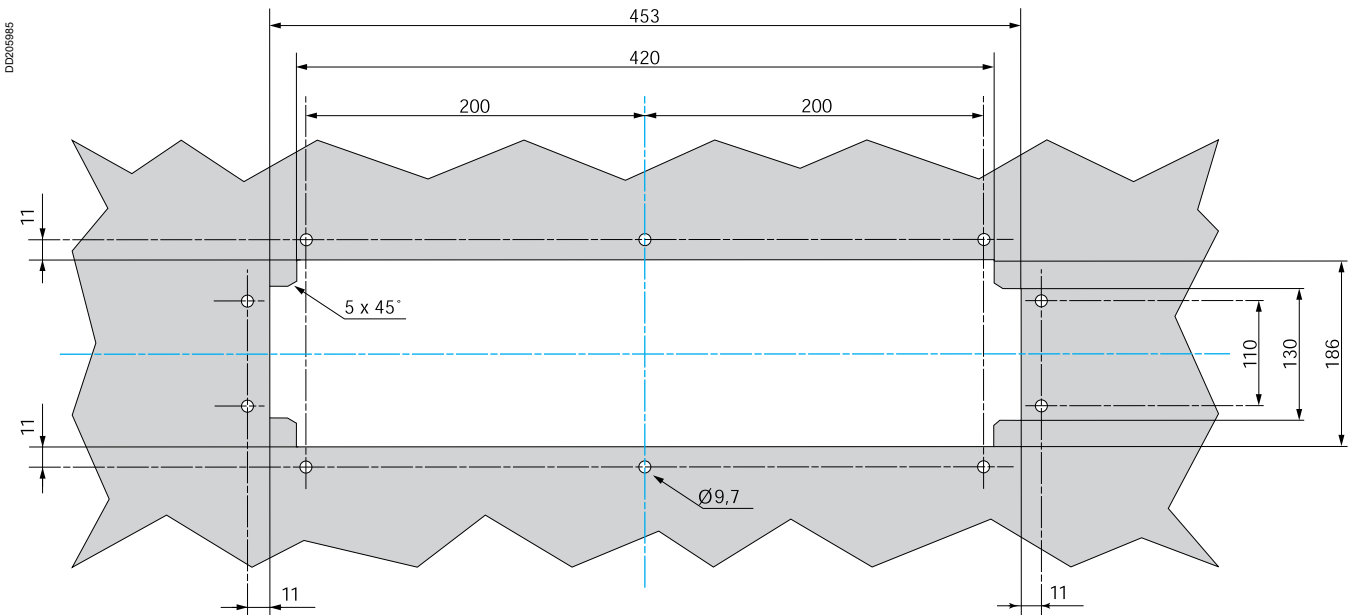

— — — Centre lines.



# Installation guide

## Connection to LV switchboards

### By universal feed unit

#### Canalis KTA



Busbars in switchboard  
(recommended distance between centres = 115 mm)

Canalis KT can be connected to switchboards via a universal connector. To simplify the work, it is advised to fit the switchboard busbars with a **distance between centres of 115 mm**.

Joining with the switchboard is via a straight or elbow universal feed unit with a straight or flat outlet.

Connections are made using torque nuts offering both ease of use and the possibility of a visual check before energising.

#### Enclosure depth depending on the rating of the trunking

Rating of trunking (A)	Depth Y of universal feed unit plate (mm)	Minimum depth X of switchboard (mm)
1000 to 1250	230	400
1600 to 2500	350	400
3200 to 4000	510	600

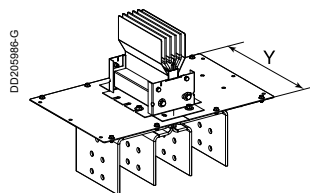

KTA●●●●ER●●

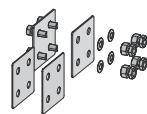

KTA0000YB2

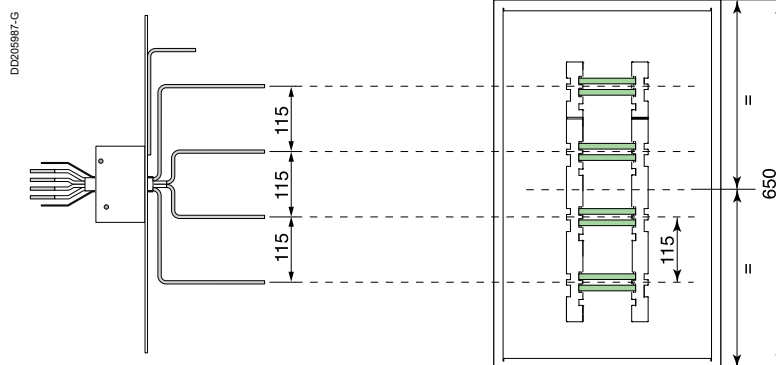
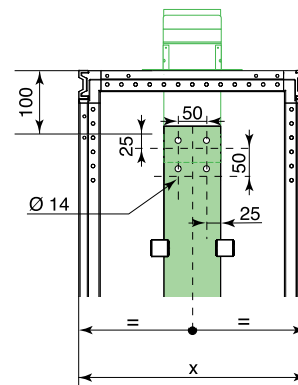

#### Phase order

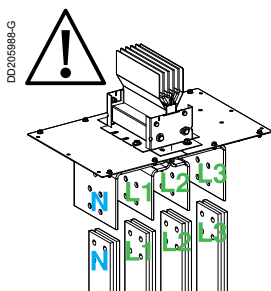

If the order of the phases in the trunking and the switchboard is different, it is advised to invert the phases in the switchboard. If that is not possible, use the phase and neutral crossover components. For more information, see the "Description" section, page 33 and "Catalogue numbers and dimensions" section, page 56.

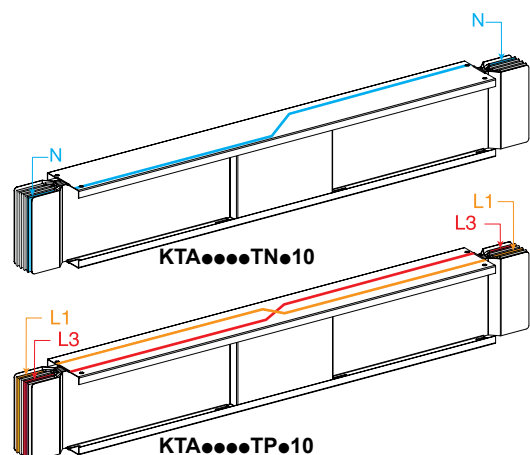

# Installation guide

## Connection to LV switchboards

### By universal feed unit

#### Cut-out drawing

It is advised to cut out the switchboard roof in the workshop.

**Cut-out for universal feeder unit, with distance between centres = 115 mm**

Rating of trunking (A)	Depth Y of universal feed unit plate (mm)
1000 à 1250	230
1600 à 2500	350
3200 à 4000	510

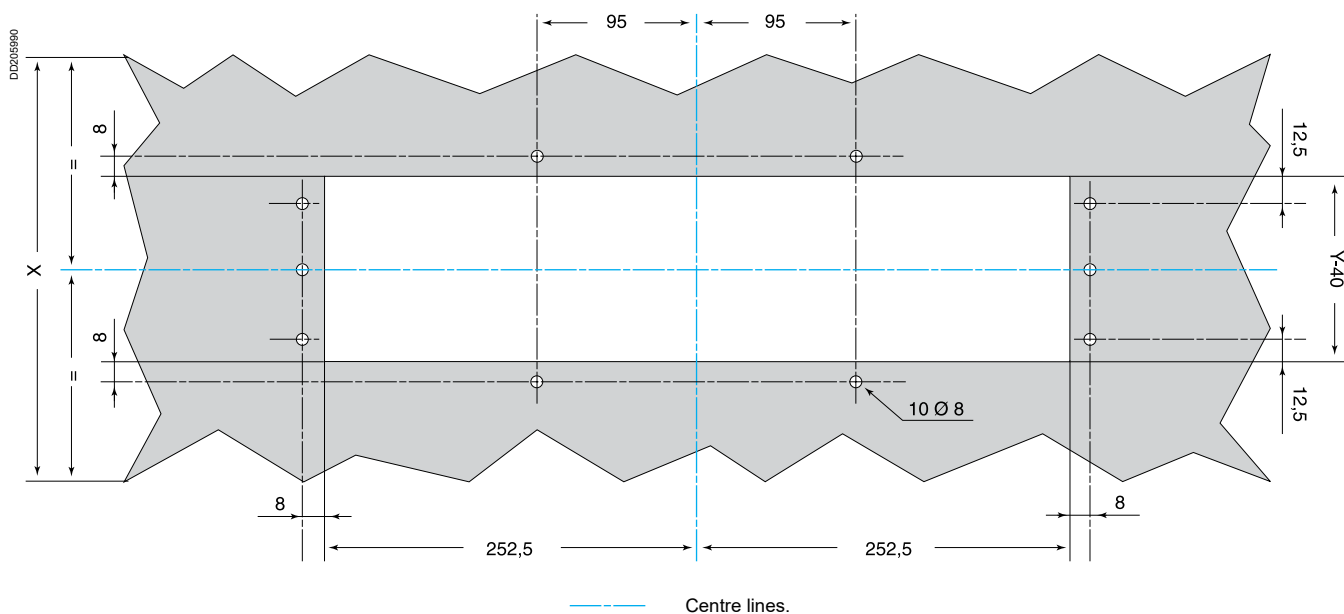

# Connection to LV switchboards

## By feed and connection plates

### Canalis KTA

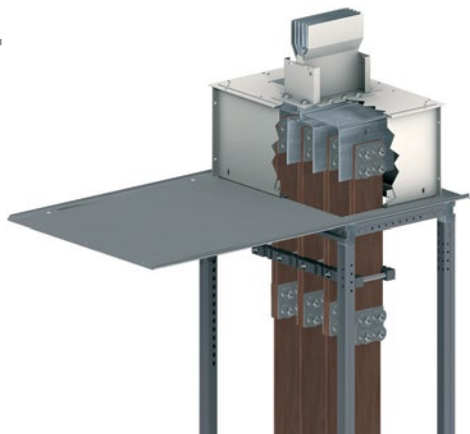

Universal feed unit  
(recommended distance between centres = 115 mm)

Connection plates are flexible copper bars, insulated or not, and drilled at one or both ends. They are supplied with bolts, washers and torque nuts for connection to straight or elbow universal feed units.

To simplify the work, it is advised to universal feed units with a **distance between centres of 115 mm**.

#### Enclosure depth depending on the rating of the trunking

Rating of trunking (A)	Depth Y of universal feed unit plate (mm)	Minimum depth X of switchboard (mm)
1000 to 1250	230	400
1600 to 2500	350	400
3200 to 4000	510	600

Vertical incomer

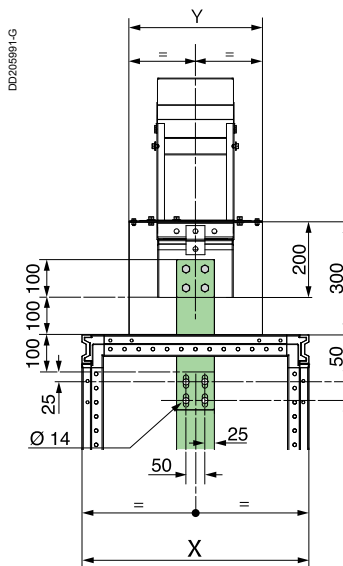

Horizontal incomer

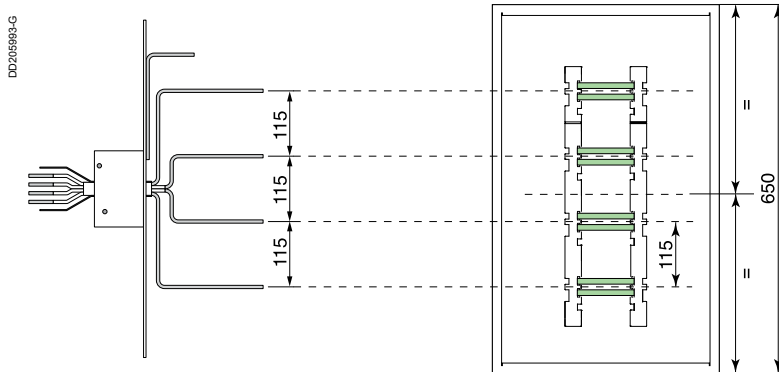
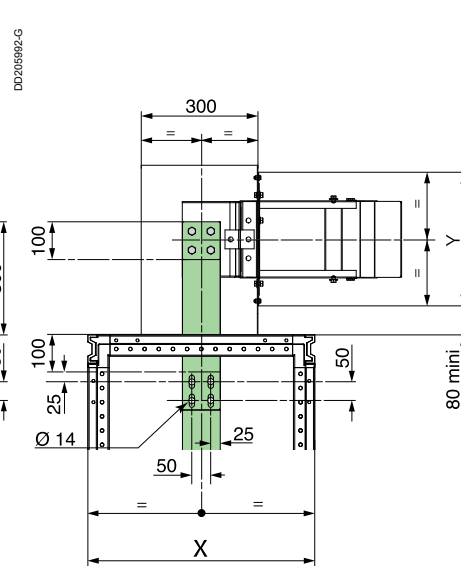

KTA●●●●ER●●

A

B

C

D

E

F

G

# Connection to LV switchboards By feed and connection plates

## Selection of connection plates

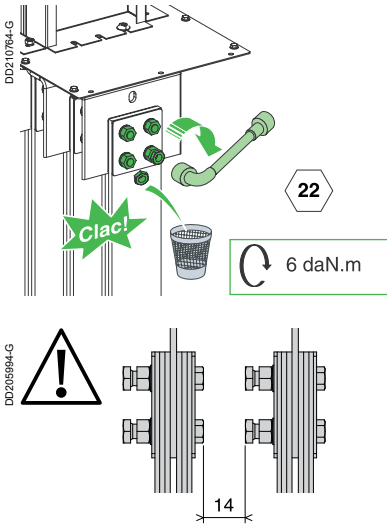

The required number of connection plates is indicated in the table below.

Busbar trunking rating (A)	Bare copper connection plates per phase	
	Number <sup>(1)</sup>	Section (mm <sup>2</sup> )
1000	2 (100 x 5)	1000
1250	2 (100 x 5)	1000
1600	2 (100 x 5)	1000
2000	3 (100 x 5)	1500
2500	3 (100 x 5)	1500
3200	4 (100 x 5)	2000
4000	5 (100 x 5)	2500
5000	6 (120 x 5)	3600

Connection plates	DD210786-G	DD210787-G	DD210788-G	DD210789-G	DD208057-G
	1 1	1 2	2 2	2 3	3 3
Busbar trunking rating (A)	1000 to 1600	2000 to 2500	3200	4000	5000

(1) The number of bimetal aluminium copper connections per phase is the same as bare copper ones.

Note: 2 (100 x 5) bare copper can be replaced by 2 (100 x 7) bimetal aluminium copper.

## Short-circuit withstand

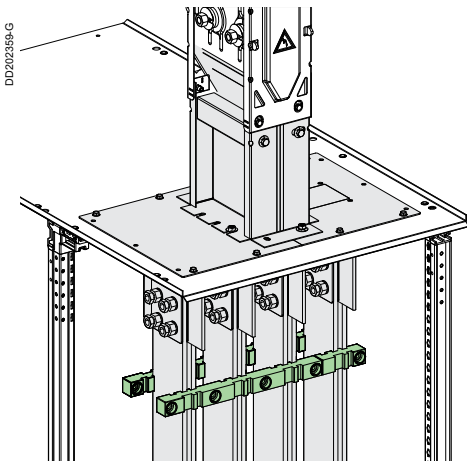

## Short-circuit withstand table

Short-time withstand current (I <sub>cw</sub> )	Maximum distance between support centres X (mm)
≤ 43 kA	400
43 kA ≤ I <sub>cw</sub> ≤ 50 kA	225
50 kA ≤ I <sub>cw</sub> ≤ 100 kA	150

## Vertical incomer

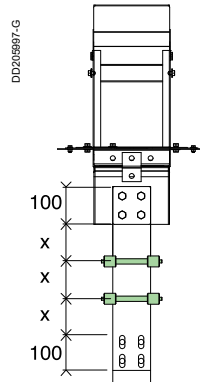

## Horizontal incomer

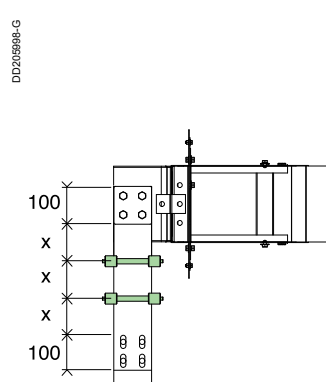

## Phase order

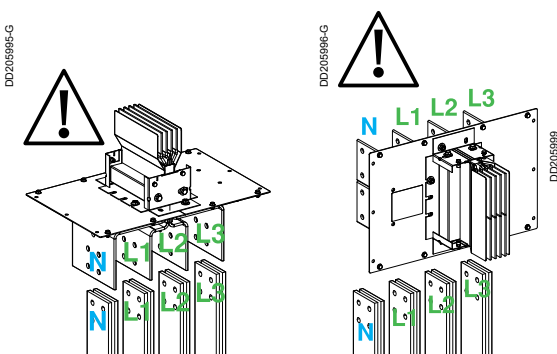

If the order of the phases in the trunking and the switchboard is different, it is advised to invert the phases in the switchboard. If that is not possible, use the phase and neutral crossover components.

For more information, see the "Description" section, page 33 and "Catalogue numbers and dimensions" section, page 56.

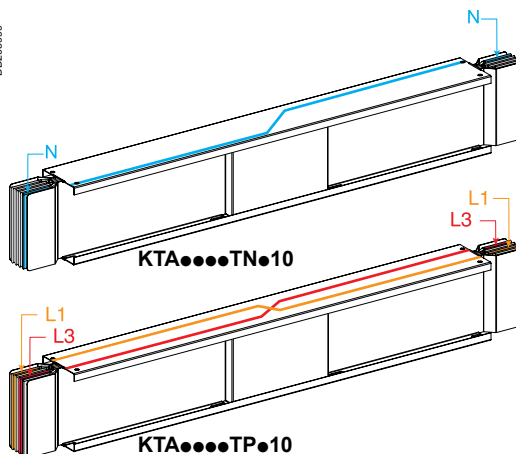

# Installation guide

## Connection to LV switchboards

### By feed and connection plates

#### Canalis KTA

#### Dimensions of protective covers

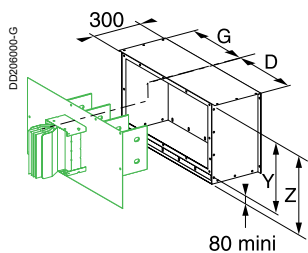

KTB●●●●CR1

#### Horizontal incomer

Rigid horizontal cover KTB●●●●CR1 for ER straight outlet feed connectors type N1 to N6

Rating (A)	Dimensions (mm)			
	Y	D	G	Z
800 to 1250	230	220 to 475	220 to 475	310 to 800
1600 to 2500	350	220 to 475	220 to 475	430 to 800
3200 to 4000	510	220 to 475	220 to 475	590 to 800

#### Cut-out drawing

It is advised to cut out the switchboard roof in the workshop..

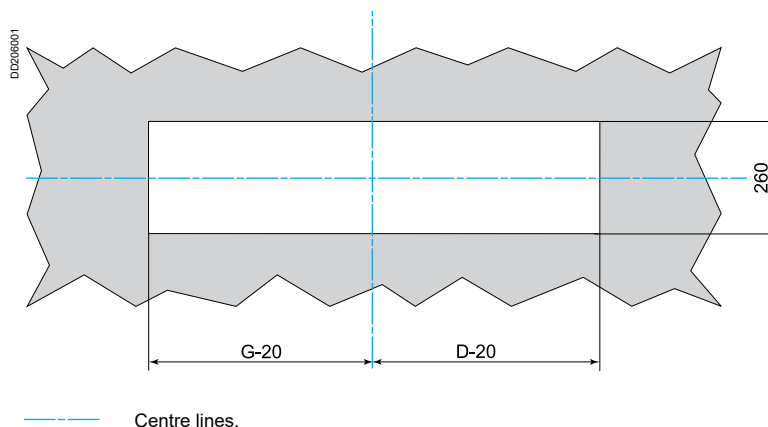

A

B

C

D

E

F

G

# Connection to LV switchboards By feed and connection plates

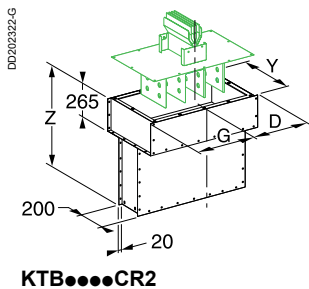

**KTB...CR2**

### Cut-out drawing

It is advised to cut out the switchboard roof in the workshop.

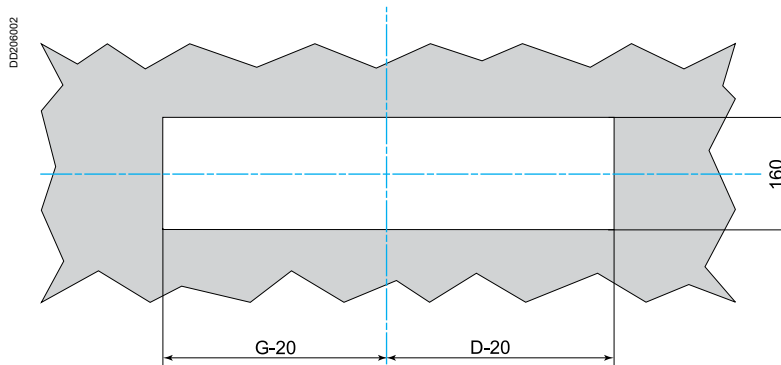

--- Centre lines.

**Rigid vertical cover KTB...CR3 (100 to 400 mm height) for ER straight outlet feed connectors type N1 to N6**

Rating (A)	Dimensions (mm)			
	Y	D	G	Z
800 to 1250	230	220 to 475	220 to 475	400 to 800
1600 to 2500	350	220 to 475	220 to 475	400 to 800
3200 to 4000	510	220 to 475	220 to 475	400 to 800

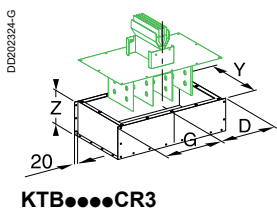

**KTB...CR3**

### Cut-out drawing

It is advised to cut out the switchboard roof in the workshop.

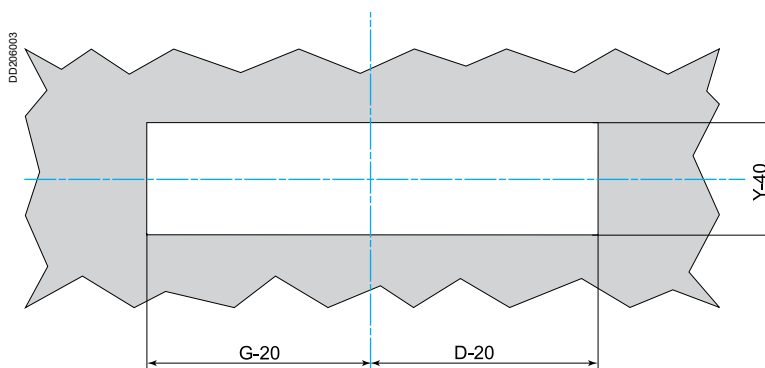

--- Centre lines.



# Connection to cast resin transformers

## Selection guide

### Canalis KTA

This guide will allow you to:

- choose the connection best suited to your layout (incoming direction, flat or edgewise busbar trunking, possibility of adjusting phase order)
- check the total height of the link with respect to the premises' ceiling height, dimension  $Z_0 + Z_2$  (plan for 100 mm minimum between the upper point of the link and the ceiling)
- optimise your link whilst respecting the following rule:  
 $(Z_0 + Z_1)_{\text{switchboard}} = (Z_0 + Z_1)_{\text{transformer}}$  to avoid multiple elbows to change levels
- position the sections for the busbar trunking supports.

A

B

C

D

E

F

G

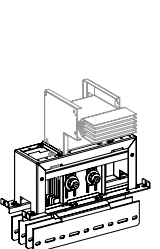
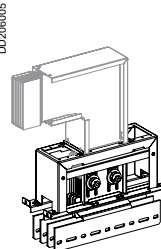
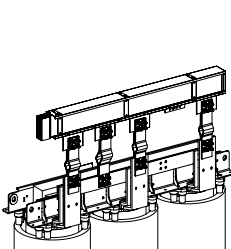
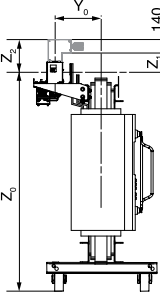
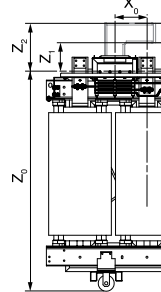
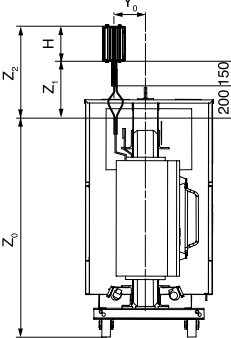
Type of connection	Connection with interface to Trihal transformers		Universal connection
	TS1	TS2	TS3
			
			
$Z_0$	See page 228	See page 228	According to manufacturer's drawing
$Z_1$ minimum	230	238	350
$Z_1$ maximum	-	-	350
$Z_2$	$Z_1 + 140$	$Z_1 + H$	$Z_1 + H$
Selecting phase order	Fixed	Fixed	At time of order
Front or rear exit	■		
Right or left exit		■	■
Edgewise layout		■	■
Flat layout	■		

# Installation guide

## Connection to cast resin transformers

### Selection guide



#### Trunking cross-section

Rating (A)	800 <sup>(1)</sup>	1000	1250	1600	2000	2500	3200	4000	5000
<div style="display: flex; align-items: center;"> <div style="writing-mode: vertical-rl; transform: rotate(180deg); font-size: 8px; margin-right: 5px;">DD210867</div> </div>									

(1) Important: for the 800 A rating, indicate "KTA0800".

TS4	TS5	TS6	TS7	TS8						
<div style="display: flex; align-items: center;"> <div style="writing-mode: vertical-rl; transform: rotate(180deg); font-size: 8px; margin-right: 5px;">DD208007</div> </div>	<div style="display: flex; align-items: center;"> <div style="writing-mode: vertical-rl; transform: rotate(180deg); font-size: 8px; margin-right: 5px;">DD208008</div> </div>	<div style="display: flex; align-items: center;"> <div style="writing-mode: vertical-rl; transform: rotate(180deg); font-size: 8px; margin-right: 5px;">DD208009</div> </div>	<div style="display: flex; align-items: center;"> <div style="writing-mode: vertical-rl; transform: rotate(180deg); font-size: 8px; margin-right: 5px;">DD208010</div> </div>	<div style="display: flex; align-items: center;"> <div style="writing-mode: vertical-rl; transform: rotate(180deg); font-size: 8px; margin-right: 5px;">DD208011</div> </div>						
According to manufacturer's drawing	According to manufacturer's drawing	According to manufacturer's drawing	According to manufacturer's drawing	According to manufacturer's drawing						
280	350	280	350	-						
280 <sup>(1)</sup>	350 <sup>(1)</sup>	280 <sup>(1)</sup>	350 <sup>(1)</sup>	-						
420 <sup>(1)</sup>	Z <sub>1</sub> + H	420 <sup>(1)</sup>	<table style="width: 100%; border-collapse: collapse;"> <tr> <td style="width: 50%;">H = 74 or 104 or 124 mm</td> <td style="width: 50%;">Z<sub>1</sub> + H/2 + 115</td> </tr> <tr> <td>H = 164 or 204 or 244 mm</td> <td>Z<sub>1</sub> + H/2 + 175</td> </tr> <tr> <td>H = 324 or 404 mm</td> <td>Z<sub>1</sub> + H/2 + 255</td> </tr> </table>	H = 74 or 104 or 124 mm	Z <sub>1</sub> + H/2 + 115	H = 164 or 204 or 244 mm	Z <sub>1</sub> + H/2 + 175	H = 324 or 404 mm	Z <sub>1</sub> + H/2 + 255	500 <sup>(1)</sup>
H = 74 or 104 or 124 mm	Z <sub>1</sub> + H/2 + 115									
H = 164 or 204 or 244 mm	Z <sub>1</sub> + H/2 + 175									
H = 324 or 404 mm	Z <sub>1</sub> + H/2 + 255									
At time of order	At time of order	At time of order	At time of order	At time of order						
■		■	■							
		■								
■			■							

(1) To use standard connection plates L = 406 mm in accordance with our recommendations.

# Connection to Trihal cast resin transformers By Canalis interface

## Canalis KTA

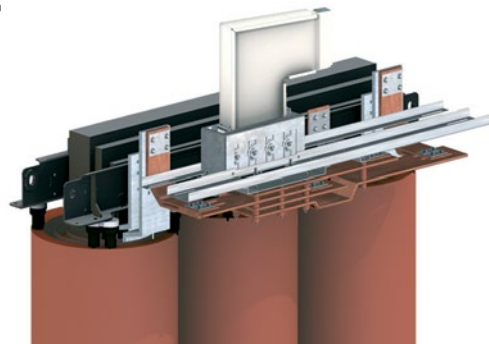

The Trihal dry-type transformers are supplied with a specific interface tested to receive the Canalis KT busbar trunking. Joining with the switchboard is achieved using a standard run section (straight, elbow section, etc) and a joint block identical to that for connecting run elements.

The Canalis KT/dry type transformer interface, which is fitted to the transformer, is designed to accept the transformer's 25 % overload in the case of forced ventilation.

**The connections are tested and qualified in normal operating conditions with respect to temperature rise ( $\Delta\theta$ ) and short-circuits (Isc).**

The busbar trunking is quickly connected to the dry-type transformer using a simple joint block with torque nuts, guaranteeing tightening torque.

**Table of compatibility between Canalis KT and the connection interface for naturally ventilated (AN) dry-type transformers.**

Dry-type transformer				Canalis KTA	
Rating (kVA)	I nominal <sup>(1)</sup> (A)	Interface		Cross-section	Type
		Type	Junction Rating (A)		
630	887	1	H124 1250	140 x 104	KTA1000
800	1126	2	H164 1600	140 x 124	KTA1250
1000	1408	3	H204 2000	140 x 164	KTA1600
1250	1760	4	H244 2500	140 x 204	KTA2000
1600	2253	5	H324 3200	140 x 244	KTA2500
2000	2816	6	H404 4000	140 x 324	KTA3200
2500	3520	7	H404 5000	140 x 404	KTA4000

(1) I is given as an indication only and is calculated with U - 410 V.

**Table of compatibility between Canalis KT and the connection interface for forced ventilated (AF) dry-type transformers.**

Dry-type transformer				Canalis KTA	
Rating (kVA)	I nominal <sup>(1)</sup> (A)	Interface		Cross-section	Type
		Type	Junction Rating (A)		
630	1108	1	H124 1250	140 x 124	KTA1250
800	1407	2	H164 1600	140 x 164	KTA1600
1000	1760	3	H204 2000	140 x 204	KTA2000
1250	2253	4	H244 2500	140 x 244	KTA2500
1600	2816	5	H324 3200	140 x 324	KTA3200
2000	3520	6	H404 4000	140 x 404	KTA4000

(1) I is given as an indication only and is calculated with U - 410 V.

If, for reasons of busbar trunking operating conditions or performance requirements, you have to use a rating other than those defined in the above tables, consult us.

## Phase order

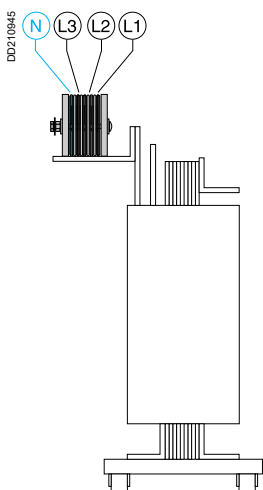

If the phase order of the busbar trunking is different to that of the switchboard's busbars, it is recommended a phase inversion is carried out in the switchboard. If this cannot be done, use the phase and neutral transposition section. For more information, see the "Description" section, page 33 and "Catalogue numbers and dimensions" section, page 56.

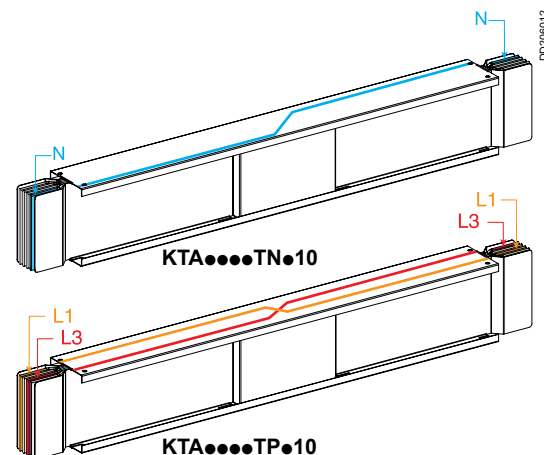

# Connection to Trihal cast resin transformers By Canalis interface

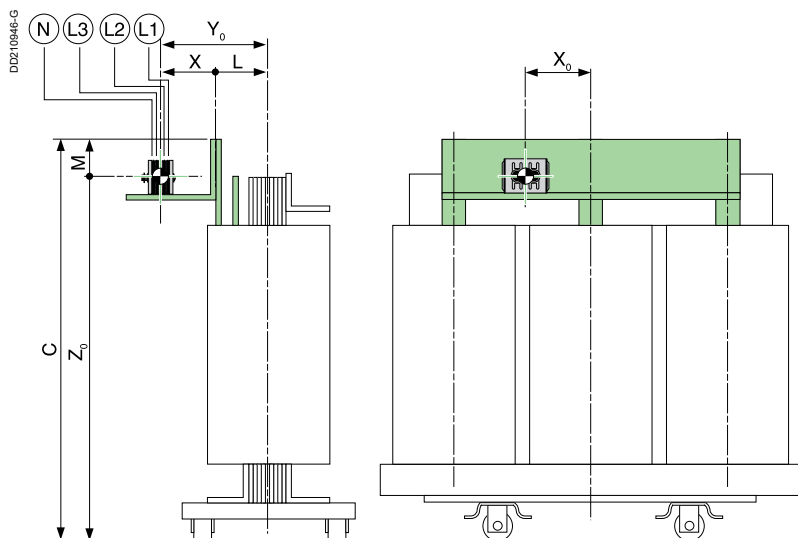

Reference point

## Dimensions

### Dimensions X, M and X<sub>0</sub>

Dimensions (mm)	Transformer power (kVA)						
	630	800	1000	1250	1600	2000	2500
X	147	150	170	147	150	170	153
M	100	100	108	93	124	144	149
X <sub>0</sub>	233	215	265	245	300	300	322.5
Interface type	1	2	3	4	5	6	7

### Dimensions Y<sub>0</sub> and Z<sub>0</sub>

$$Y_0 = X + L$$

$$Z_0 = C - M$$

Dimensions C and L are different according to country standards.

### French standard

FT no.235627 rev. 3 - Primary voltage: 20 kV - Insulation voltage: 24 kV  
-Secondary voltage: 410 V

Dimensions (mm)	Transformer power (kVA)						
	630	800	1000	1250	1600	2000	2500
C	1614	1744	1749	1929	2089	2209	2297
L	220	225	240	240	240	257	275

### German standard

FT no.235763 rev. 0 - Primary voltage: 20 kV - Insulation voltage: 24 kV -  
Secondary voltage: 400 V

Dimensions (mm)	Transformer power (kVA)						
	630	800	1000	1250	1600	2000	2500
C	1734	1744	1749	2019	1979	2199	2279
L	210	220	225	245	255	255	265

### Spanish standard

FT no.235515 rev. 3 - Primary voltage: 20 kV - Insulation voltage: 24 kV -  
Secondary voltage: 420 V

Dimensions (mm)	Transformer power (kVA)					
	630	800	1000	1250	1600	2000
C	1614	1744	1879	1929	1979	2194
L	220	225	215	245	250	245

### Belgian standard

FT no.235820 rev. 0 - Primary voltage: 15 kV - Insulation voltage: 17.5 kV -  
Secondary voltage: 400 V

Dimensions (mm)	Transformer power (kVA)						
	630	800	1000	1250	1600	2000	2500
C	1484	1564	1694	1844	2054	2149	2164
L	215	210	215	225	230	255	235

# Connection to Trihal cast resin transformers

By Canalis interface

## Canalis KTA

### Sealing kit

The sealing kit must be ordered with the KT busbar trunking. The busbar trunking size defines the sealing kit size. For the different types of kit, see «Catalogue numbers / Dimensions». The kit includes a drilling and cut-out template for the dry-type transformer panels.

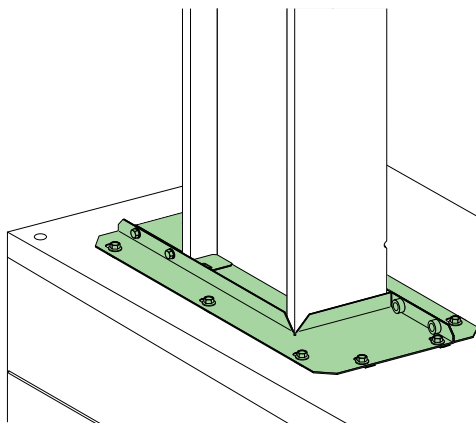

KTB0...TT01

### Cut-out drawing

It is recommended that the cutting-out of the transformer panels is done in the workshop.

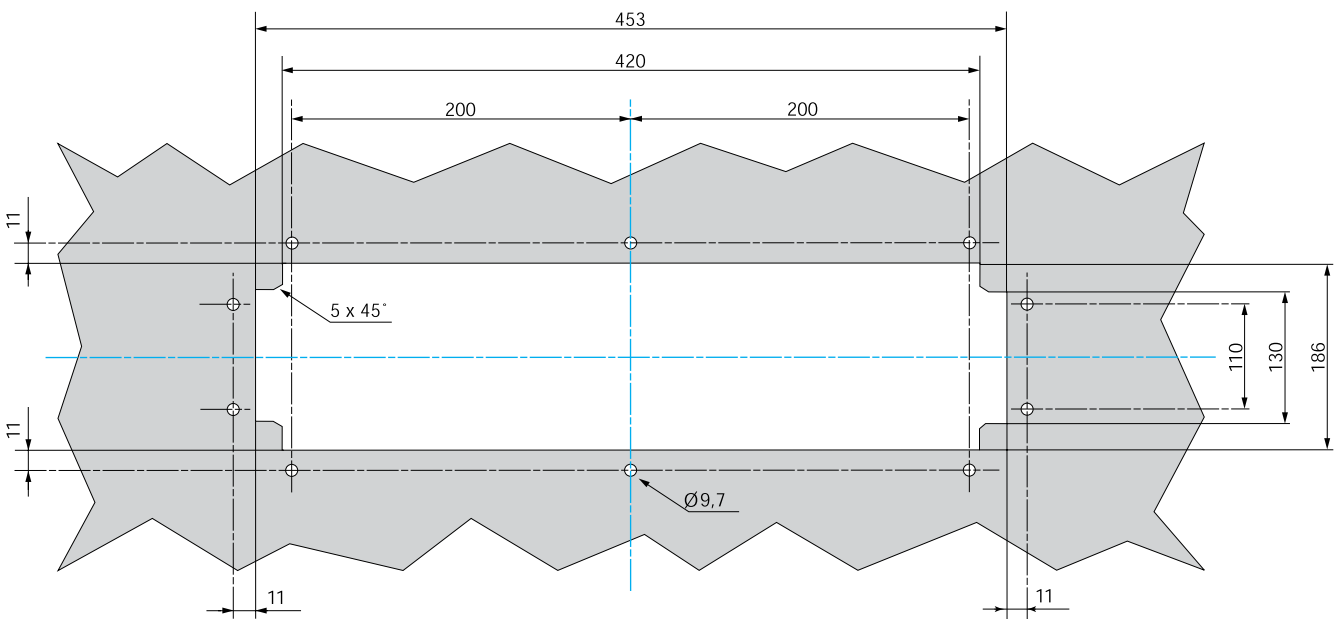

— Junction axis.

# Connection to cast resin transformers By universal feed and connection plates

PD020330\_1

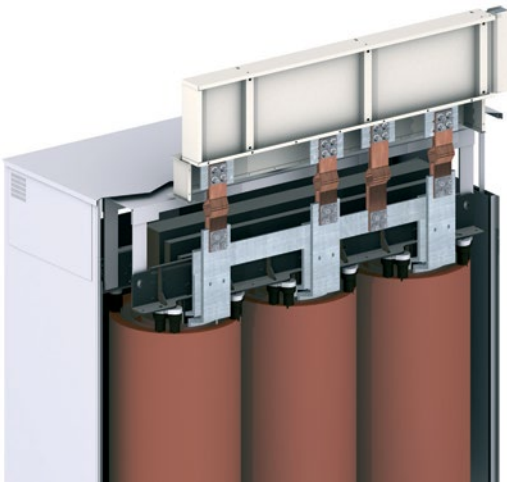

Canalis KT can be connected to cast resin transformers using a universal feed. The connection is made using a flexible busbar (connection plates or braids) to avoid transmitting vibrations and expansions. The connection plates are made up of either insulated or non-insulated flexible copper bars, drilled at one or both ends. A nut and bolt kit allows connection to the feed. The connections use torque-head bolts which provide both ease of installation and visual inspection of correct tightening before energising.

If the transformer is supplied with panels, provide for an additional cover to maintain the protection degree.

### Choice of Canalis KT busbar trunking rating according to transformer power.

Transformer Power (kVA)	I nominal <sup>(1)</sup> (A)	KTA rating at nominal power <sup>(2)</sup> (A)
630	887	1000
800	1126	1250
1000	1408	1600
1250	1760	2000
1600	2253	2500
2000	2816	3200
2500	3520	4000

(1) I is given as an indication only and is calculated with U = 410 V and at transformer nominal setting, without forced ventilation.

(2) The busbar trunking rating is defined for normal operating conditions.

### Recommended configurations for short-circuit withstand (connection plate L = 400 mm)

#### TS3 and TS5 universal connection, edgewise mounting

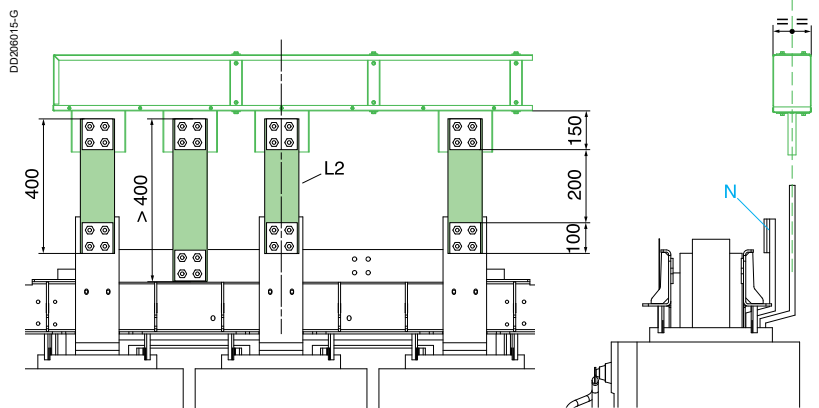

KTA●●●●EL●1 or KTA●●●●EL●2 or KTA●●●●EL●3 or KTA●●●●EL●4

#### TS4 and TS6 universal connection, flat mounting (using angle brackets)

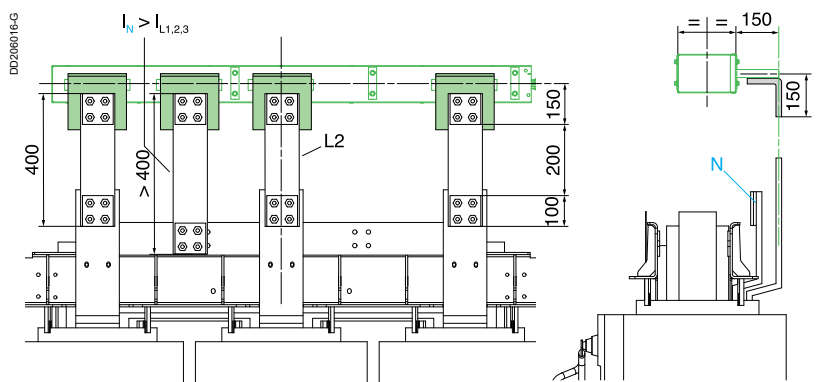

KTA●●●●EL●1 or KTA●●●●EL●2 or KTA●●●●EL●3 or KTA●●●●EL●4 with angle bracket KTB0000YE1



# Connection to cast resin transformers

## By universal feed and connection plates

### Canalis KTA

- A
- B
- C
- D
- E
- F
- G

TS7 universal connection, edgewise mounting

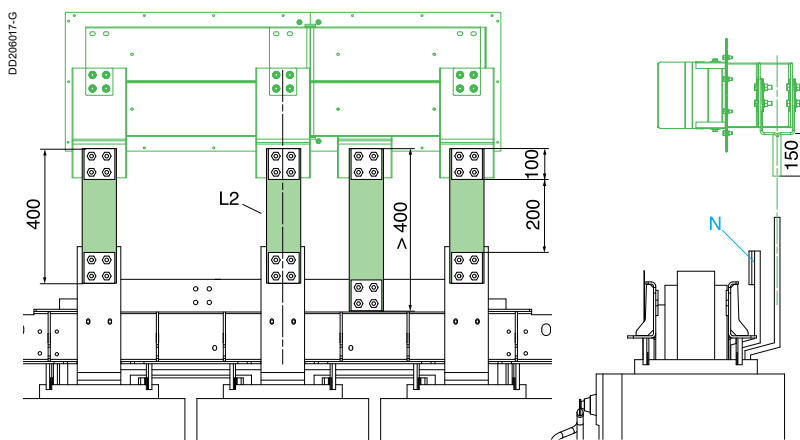

KTA●●●●EL●5

TS7 universal connection, flat mounting (using angle brackets)

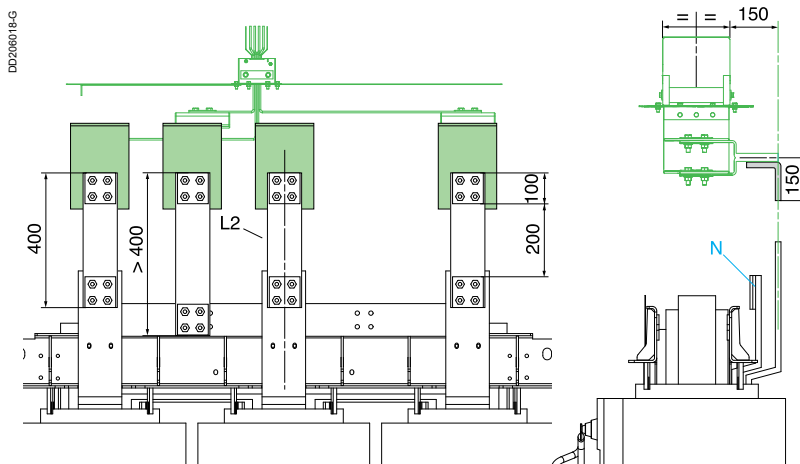

KTA●●●●EL●5 with angle bracket KTB0000YE

### Definition of connection plates

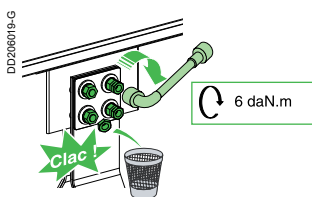

The number of connection plates is defined in the table below:

Busbar trunking rating (A)	Bare copper connection plates per phase	
	Number <sup>(1)</sup>	Cross-section (mm <sup>2</sup> )
1000	2 (100 x 5)	1000
1250	2 (100 x 5)	1000
1600	2 (100 x 5)	1000
2000	3 (100 x 5)	1500
2500	3 (100 x 5)	1500
3200	4 (100 x 5)	2000
4000	5 (100 x 5)	2500
5000	12 (YC5 - 100 x 5)	5000

Connection plates	DD210786-G	DD210787-G	DD210788-G	DD210789-G	DB429105-G
	1 1	1 2	2 2	2 3	2x3 2x3
Busbar trunking rating (A)	1000 to 1600	2000 to 2500	3200	4000	5000

(1) The number of bimetal aluminium copper connections per phase is the same as bare copper ones.

Note: 2 (100 x 5) bare copper can be replaced by 2 (100 x 7) bimetal aluminium copper.

# Connection to cast resin transformers

## By universal feed and connection plates

### Phase order

Phase selection is made when the feed is ordered. Phase L2 is fixed and can therefore be used as a reference for installing the feed on the transformer.

#### The different phase selection possibilities (T)

- Dedicated feeds N1 to N4,

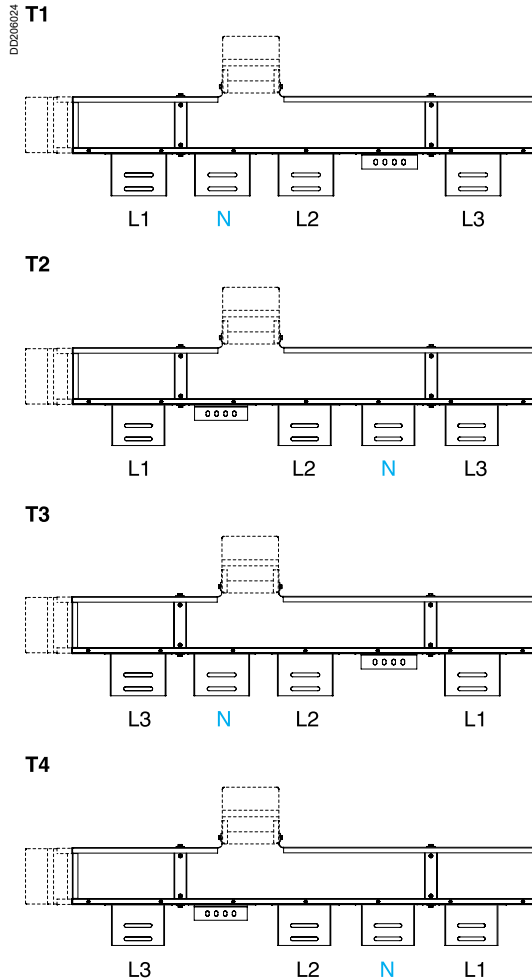

**Important:** the drawings and references above correspond to a phase order of N321, joint block side. If the phase order on the joint block side is N123, inverse T=1 with T=3 and T=2 with T=4.

- Feed with flat bars N5.

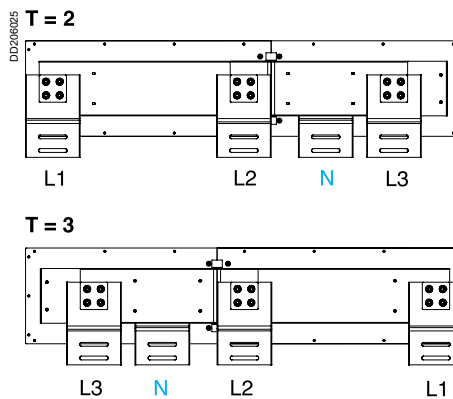

**Important:** the drawings and references above correspond to a phase order of N321, joint block side. If the phase order on the joint block side is N123, inverse L1 and L3 on the transformer side marking.



# Connection to cast resin transformers

## By universal feed and connection plates

### Canalis KTA

#### Dimensions of protective covers

A

B

C

D

**E**

F

G

#### Vertical protection covers for dry-type transformer feeds N1, N2, N3 and N4

Rating (A)	Dimensions (mm)		
	Y	Z	
		Minimum	Maximum
800 to 1250	230	200	350
1600 to 2500	350	200	350
3200 to 4000	510	200	350

#### KTB0000CR4

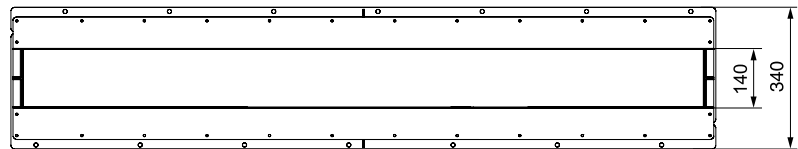
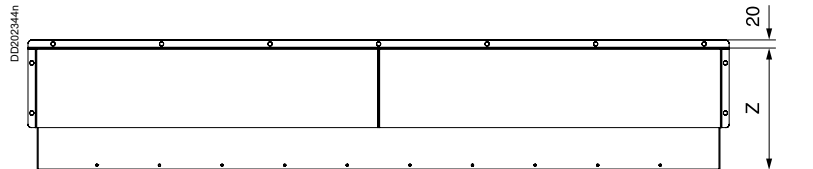

#### Horizontal protection covers for dry-type transformer feeds N1, N2, N3 and N4

Rating (A)	Dimensions (mm)		
	Y	Z	
		Minimum	Maximum
800 to 1250	230	330	480
1600 to 2500	350	330	480
3200 to 4000	510	330	480

#### KTB0000CR5

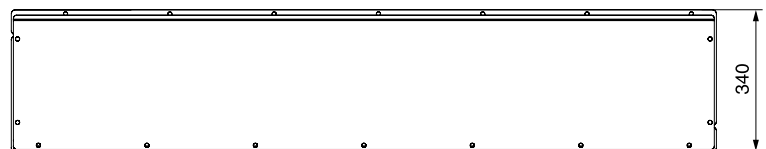
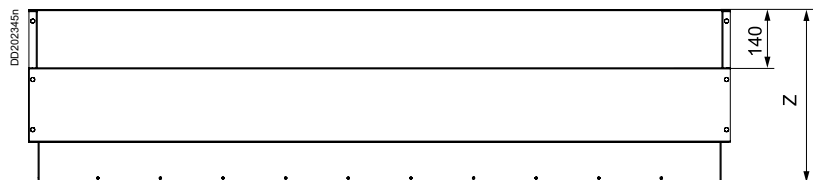

# Connection to cast resin transformers

## By universal feed and connection plates

### Horizontal protection cover for dry-type transformer feed N5

Rating (A)	Dimensions (mm)		
	Y	Z Minimum	Z Maximum
800 to 1250	230	380	530
1600 to 2500	350	500	650
3200 to 4000	510	660	810

### KTB●●●●CR6

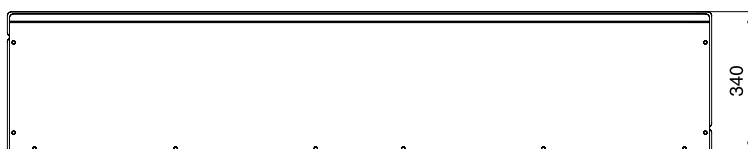
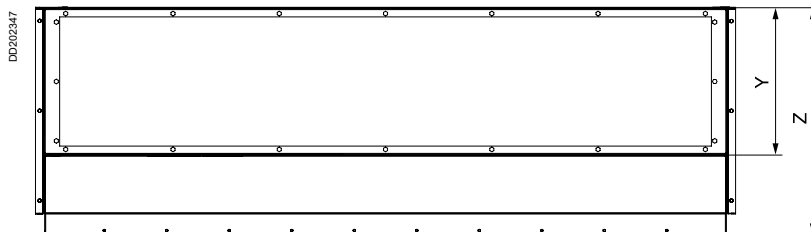

### Cut-out drawing for dry-type transformer panels

It is recommended that the cutting-out of the transformer panels is done in the workshop.

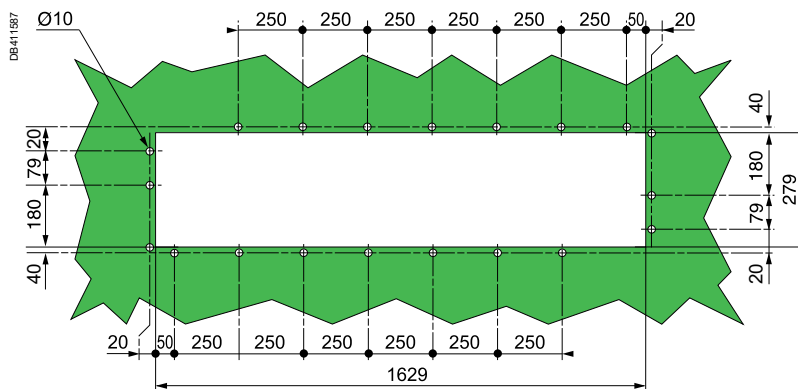

View from the top of the transformer.



# Connection to Minera immersed transformers

## Horizontal selection guide

### Canalis KTA

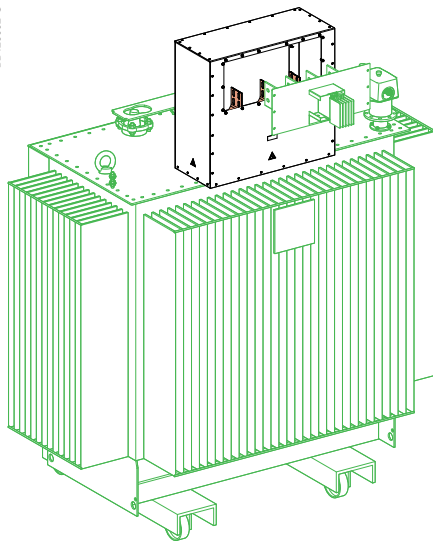

Canalis KT is easily connectable to Minera transformers. A pre-designed interface including cover, flexible links and bolts is installed in place of the cable box delivered (or not) with the transformer. This solution that connects end feed units ER1 to ER6, make the design simple and fast.

- Position of the flange is given by the table 1.
- Products that compose the interface are given in the table 2.

The dimensions D and X are given by the Table 1.  $D_0$  and  $Z_0$  must be taken from the transformer documentation. The interface is always centered in the middle of the transformer indifferently for the 3P or 4P versions.

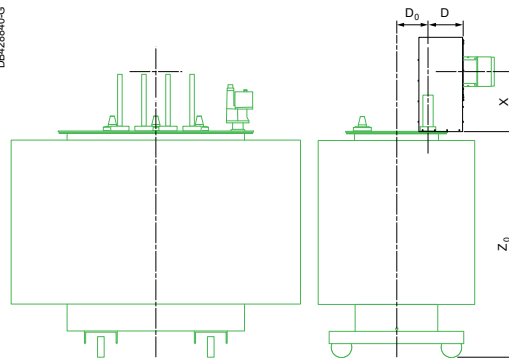

### KTA Minera interfaces composition - horizontal incomer

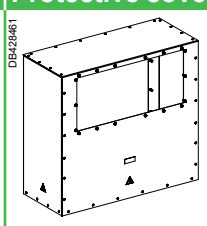
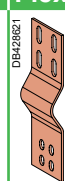
Type	Protective covers		Flexible links reference and quantity							
	Catalogue number	D (mm)	Z (mm)	Polarity	KTB0100YC307A (dimensions in mm)					
										
					L = 320 A = 32 B = 60 C = 34 D = 32 E = 2 F = 2 Y = 25	L = 320 A = 32 B = 30 C = 34 D = 32 E = 2 F = 2 Y = 25	L = 350 A = 32 B = 31 C = 15 D = 32 E = 2 F = 2 Y = 25	L = 350 A = 32 B = 31 C = 53 D = 32 E = 2 F = 2 Y = 25	L = 320 A = 32 B = 40 C = 15 D = 32 E = 2 F = 2 Y = 25	L = 320 A = 32 B = 40 C = 53 D = 32 E = 2 F = 2 Y = 25
KTA H1	KTB0230CR71	150	320	3P 4P	6 8					
KTA H2	KTB0350CR71	150	320	3P 4P	6 8					
KTA H3	KTB0350CR72	150	350	3P 4P		6 8				
KTA H4	KTB0350CR72	150	350	3P 4P		9 12				
KTA H5	KTB0350CR73	150	400	3P 4P			6 7	3 5		
KTA H6	KTB0510CR71	150	435	3P 4P					6 8	6 8
KTA H7	KTB0510CR72	180	470	3P 4P						
KTA H8	KTB0510CR72	180	470	3P 4P						
KTA H9	KTB0510CR73	180	510	3P 4P						
KTA H10	KTB0726CR71	180	469	3P 4P						

Interface details, see page 88.



# Connection to Minera immersed transformers

## Vertical selection guide

### Canalis KTA

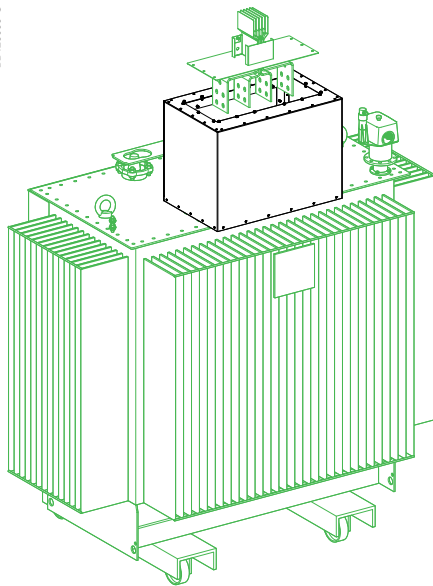

Canalis KT is easily connectable to Minera transformers.

A pre-designed interface including cover, flexible links and bolts is installed in place of the cable box delivered (or not) with the transformer.

This solution that connects end feed units ER1 to ER6, make the design simple and fast.

- Position of the flange is given by the table 1
- Products that compose the interface are given in the table 2.

The dimensions D and Z are given by the Table 1.

$D_0$  and  $Z_0$  must be taken from the transformer documentation.

The interface is always centered in the middle of the transformer indifferently for the 3P or 4P versions.

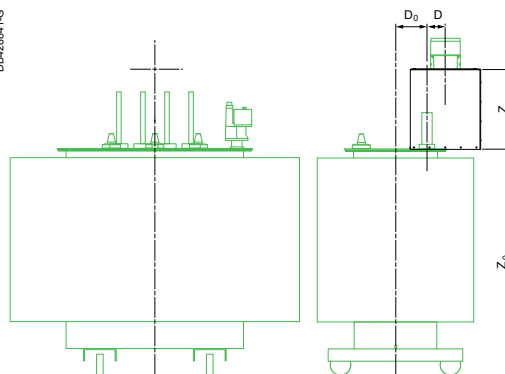

### KTA Minera interfaces composition - vertical in comer

Type	Protective covers			Flexible links reference and quantity								
	Catalogue number	D (mm)	Z (mm)	Polarity	KTB0100YC307A (dimensions in mm)					KTB0120YC307A (dimensions in mm)		
					L = 320	L = 320	L = 320	L = 320	L = 320	L = 320	L = 320	L = 340
					A = 32	A = 32	A = 32	A = 32	A = 32	A = 32	A = 50	A = 50
					B = 50	B = 50	B = 60	B = 60	B = 60	B = 32	B = 32	B = 20
					C = 15	C = 53	C = 34	C = 15	C = 53	C = 35	C = 35	C = 35
					D = 32	D = 32	D = 32	D = 32	D = 32	D = 50	D = 50	D = 50
					E = 2	E = 2	E = 2	E = 2	E = 2	E = 2	E = 2	E = 2
					F = 2	F = 2	F = 2	F = 2	F = 2	F = 2	F = 2	F = 2
					Y = 31	Y = 19	Y = 25	Y = 25	Y = 25	Y = 35	Y = 35	Y = 35
KTA V1	KTB0230CR81	106	480	3P	3	3						
				4P	4	4						
KTA V2	KTB0350CR81	106	580	3P			6					
				4P			8					
KTA V3	KTB0350CR81	106	580	3P			9					
				4P			12					
KTA V4	KTB0350CR82	126	600	3P				6	3			
				4P				7	5			
KTA V5	KTB0510CR81	126	600	3P				6	6			
				4P				8	8			
KTA V6	KTB0510CR82	179	615	3P						12		
				4P						16		
KTA V7	KTB0510CR82	179	615	3P						15		
				4P						20		
KTA V8	KTB0510CR82	179	615	3P							15	
				4P							20	
KTA V9	KTB0726CR81	179	591	3P							21	
				4P							28	

Interface details, see page 89.



# Installation guide

## Connection to oil immersed transformers

### By feed and connection plates or braids

#### Canalis KTA

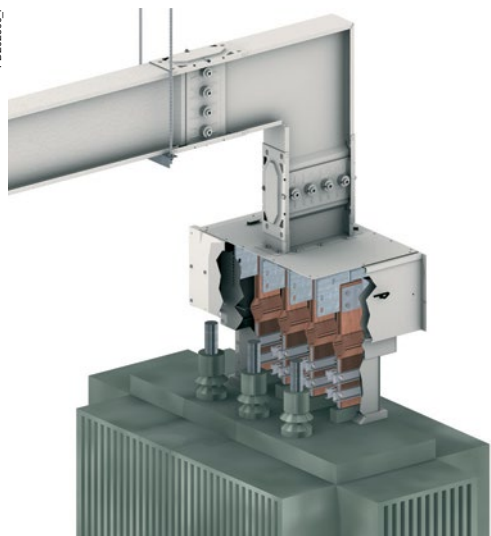

Connection to an oil immersed transformer is made using flexible bars (connection plates) to avoid transmitting transformer vibrations to the busbar trunking and to limit the stress on connection terminals.

#### Choice of busbar trunking

Dry-type transformer		Canalis KT aluminium busbar trunking	
Rating (kVA)	I nominal <sup>(1)</sup> (A)	Rating (A)	Cross-section
500	704	800	140 x 74
630	887	1000	140 x 104
800	1126	1250	140 x 124
1000	1408	1600	140 x 164
1250	1760	2000	140 x 204
1600	2253	2500	140 x 244
2000	2816	3200	140 x 324
2500	3520	4000	140 x 404

(1) I is given as an indication only and is calculated with U - 410 V.

**Note:** if, for reasons of busbar trunking operating conditions or performance requirements, you have to use a rating other than those defined in the above tables, consult us.

#### Protective cover width

Busbar trunking rating (A)	Dimensions "Y" of the feed
1000 to 1250	230
1600 to 2500	350
3000 to 4000	510

#### Recommended configurations for short-circuit withstand (connection plate L = 400 mm)

##### Vertical incomer

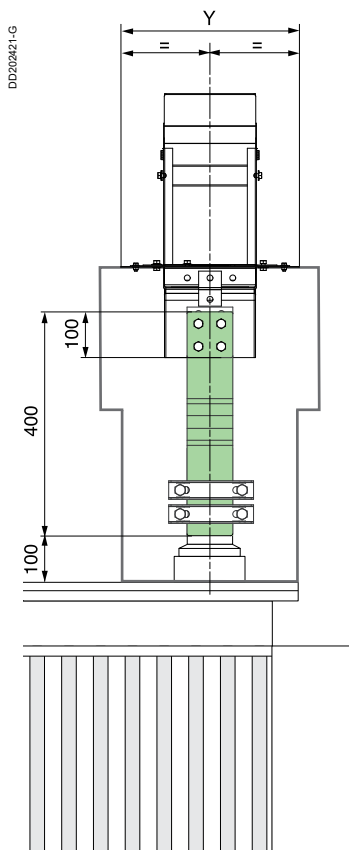

##### Horizontal incomer

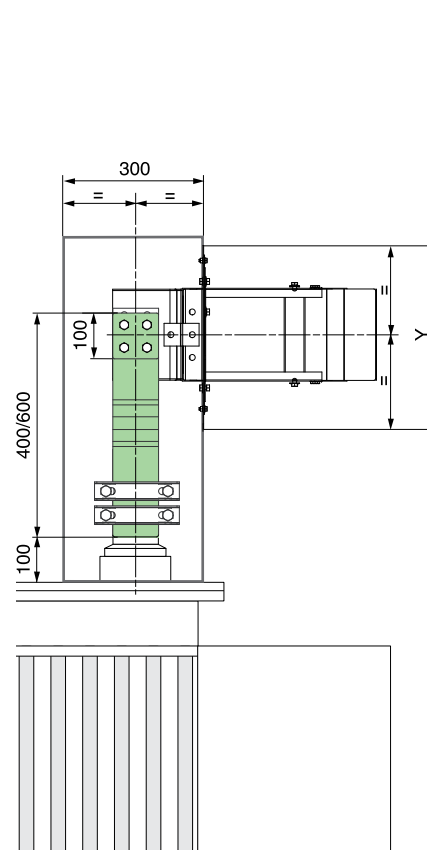

# Connection to oil immersed transformers By feed and connection plates or braids

## Several connection possibilities

With connection plates with kink and bar clamp

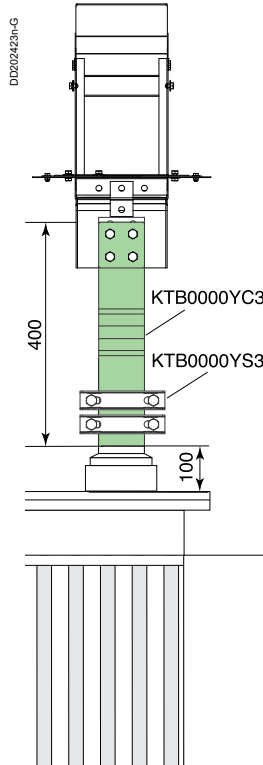

With connection plates with kink to be drilled

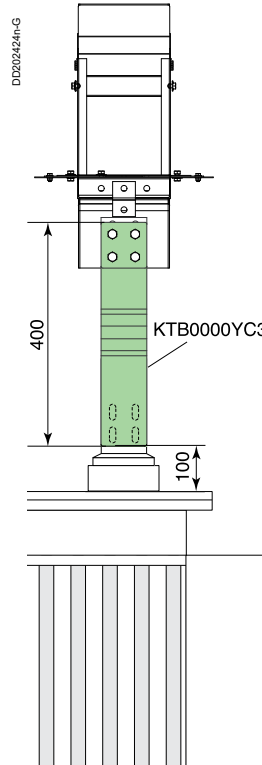

With drilled connection plates (KTB0000YC4) or braids

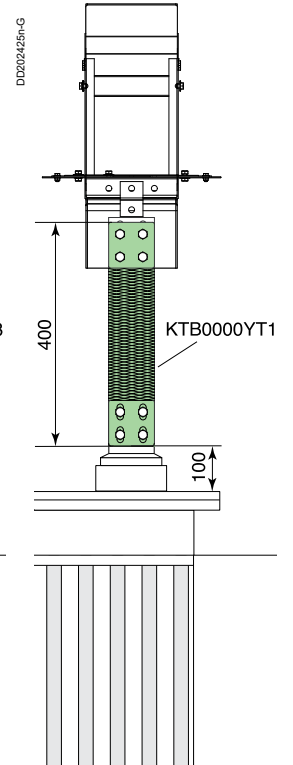

## Phase order

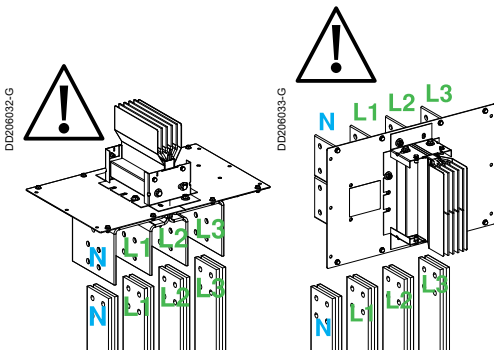

If the phase order of the busbar trunking is different to that of the switchboard's busbars, it is recommended a phase inversion is carried out in the switchboard. If this cannot be done, use the phase and neutral transposition section. For more information, see the "Description" section, page 33 and "Catalogue numbers and dimensions" section, page 56.

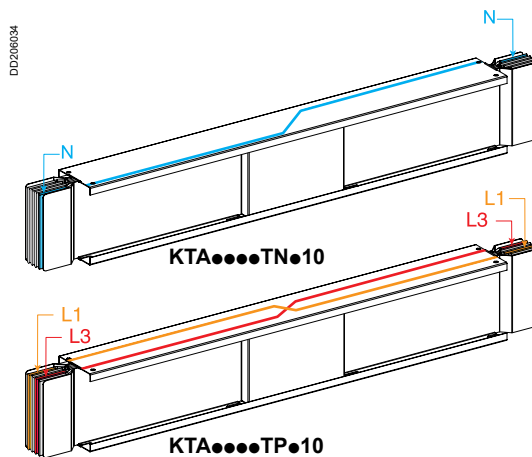

# Installation guide

## Connection to oil immersed transformers

### By feed and connection plates or braids

#### Canalis KTA

#### Definition of connection plates

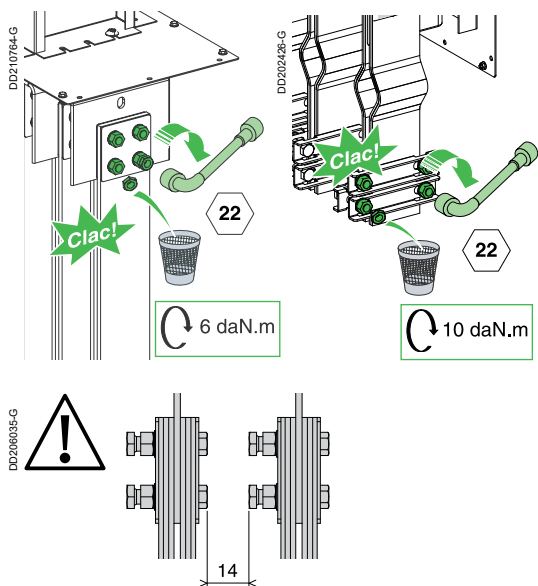

The number of connection plates is defined in the table below:

Busbar trunking rating (A)	Bare copper connection plates per phase	
	Number	Section (mm <sup>2</sup> )
1000	2 (100 x 5)	1000
1250	2 (100 x 5)	1000
1600	2 (100 x 5)	1000
2000	3 (100 x 5)	1500
2500	3 (100 x 5)	1500
3200	4 (100 x 5)	2000
4000	5 (100 x 5)	2500
5000	8 (120 x 5)	4800

Connection plates	1000 to 1600	2000 to 2500	3200	4000	5000
DD210786-G	1 1	1 2	2 2	2 3	4 4
DD210787-G					
DD210788-G					
DD210789-G					
DB428865-G					
Busbar trunking rating (A)					

#### Definition of braids



The number of braids is defined in the table below:

Busbar trunking rating (A)	Braids per phase	
	Number	Cross-section (mm <sup>2</sup> )
1000	1	600
1250	2	1200
1600	2	1200
2000	2	1200
2500	3	1800
3200	3	1800
4000	4	2400
5000	6	3000

Braids	1000	1250 to 2000	2500 to 3200	4000	5000
DD205835-G	1	1 1	1 2	2 2	3 3
DD205836-G					
DD205837-G					
DD205838-G					
DB428865-G					
Busbar trunking rating (A)					

#### Connection to porcelain bushings

Connection terminals of the type defined below must be used. These are available in the transformer manufacturers' catalogues.

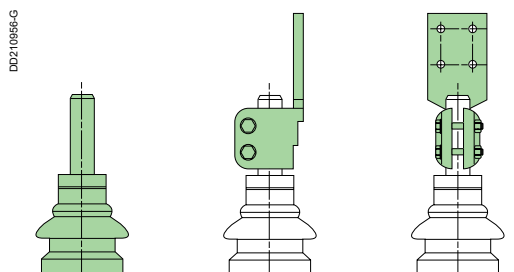

#### Cover

The transformers can be supplied with or without a low voltage cover. This cover is not used in our solutions.

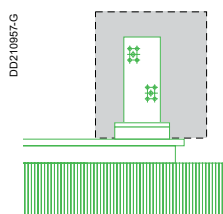

# Recommendations

Introduction	3
Presentation and description	23
Catalogue numbers and dimensions	47
Design guide	143
Installation guide	185
<b>Reception, handling and storage</b>	<b>244</b>
<b>Maintenance</b>	<b>246</b>
Run sections	246
<b>Recycling</b>	<b>247</b>
Index	248

# Reception, handling and storage

## Canalis KTA

A

This document contains practical information, lays out the general recommendations (as a complement to the installation regulations) and specifies the basic instructions that must be respected when handling and storing Schneider Electric Canalis busbar trunking system.

B

The purchaser's engineering, installation and operating staff must become acquainted with this document and become familiar with the appearance and characteristics of each of the Canalis busbar trunking system's components. Appropriate planning and coordination between the different job functions is indispensable for ensuring an efficient installation of the equipment.

C

Each Canalis busbar trunking system is carefully inspected and packaged at the assembly plant.

The entire system is checked both structurally and electrically.

At the end of inspection, the busbar trunking system is prepared for shipping.

Each section is packed to guarantee easy handling before its installation.

The catalogue number is written on each shipping unit.

D

### Warning

#### RISK OF ELECTRIC SHOCK, BURNS OR EXPLOSION

- Protect the equipment against all contact with water, salt, concrete and other corrosive surroundings both before and during installation.
- Outdoor equipment is not resistant to bad weather until after it has been fully and correctly installed.
- Do not sit or walk on the equipment.

If these instructions are not respected, the equipment may deteriorate leading to a risk of serious or mortal injury.

E

F

## Reception

Upon reception, check the information on the shipping note corresponds to the equipment received to ensure all of the order has been received and shipped. Complaints concerning missing components or other errors must be sent in writing to Schneider Electric SAS within 30 days from the date the shipping item was received. If no complaint has been received within 30 days from the date the shipping item was received, Schneider Electric SAS will no longer be responsible for repairs or replacements that may be required.

Upon reception, check the various units of the busbar trunking system immediately to identify any damage that has occurred during transport.

If there is observed or suspected damage, file a claim immediately with the carrier and inform the nearest Schneider Electric office.

G

## Handling

Handle Canalis products with the greatest of care to avoid damaging the internal components of the system and to avoid changing the external appearance of the various parts, as well as the bar ends (connection terminals).

The busbar trunking must be constantly supported by independent means, in such a way its weight is not resting on the top of the transformers or distribution switchboards.

The distance between these support means must not exceed 3 metres.

Avoid exposing the busbar trunking to twisting, embossing or impacts, and all other actions likely to causing damage.

Ensure the handling equipment available at the site of installation is suitable for handling busbar trunking. In particular, check the lifting capacity of the crane or the other lifting equipment to be used.

# Reception, handling and storage

Take great care when unpacking the equipment:

- use a nail-head puller when unpacking wooden crates
- if hauling the busbar trunking with a crane, use Nylon slings to spread the weight of the unit being lifted
- if using cables, insert a spacing means to avoid damaging the busbar trunking
- if using a forklift truck, position the busbar trunking on the forks in such a way the weight is evenly distributed.

**1** - Cut the strapping holding the packaging case using suitable cutting tools.

**2** - Use suitable tools to remove the strengthened steel packaging at each end of the busbar trunking.

Take care not to damage the steel box so as not to damage the busbar trunking. Avoid the use of objects with sharp edges when lifting the busbar trunking.

**3** - Dispose of all used packaging in an appropriate way.

Never drag the busbar trunking along the floor. Do not use the end bars to lift sections of the busbar trunking.

## Protection against humidity during storage

If the busbar trunking is not installed and commissioned immediately, leave it in the original Canalis packaging and store it in a clean and dry place at a uniform temperature.

The busbar trunking must not be stored outside. However, if outside storage is necessary, cover the busbar trunking in such a way as to protect it from bad weather and to avoid contact with the elements.

Temporary electrical heating must be provided for underneath the covering means to prevent condensation.

The supplied heat must be of suitable temperature and uniformly distributed underneath the covering means.

Outdoor busbar trunking is not resistant to bad weather until after it has been fully and correctly installed.

During installation, take particular care to protect rising mains from humidity arising from unfinished roofs, walls and other similar elements.

Deserts can provide at least 2 specific situations for KT storage from standard other locations:

- sand pollution.
- significant thermal variations nights/days that can create condensation due to the colder busduct KT compared from atmosphere when it is humid (this risk should be evaluated from local context).

About sand: When the products are not installed but in their standard transport packings, we can't completely guaranty the protection against sand/wind to not reach the products.

As it's important to keep all electrical contacts clean from any foreign body and abrasion, our products must be protected from sand during storage period before and during installation.

The optionnal sea-packaging with wood boxes is including a waterproof system, it allows to keep the products protected against the 2 above risks.

A

B

C

D

E

F

G

# Recommendations

## Maintenance

### Run sections

#### Canalis KTA

A

B

C

**A basic maintenance must be performed for any type of applications, under any conditions**

D

E

F

**A more specific maintenance must be performed when the busbar trunking system feeds critical applications or in case of unfavourable environmental conditions**

G

#### Recommended periodical maintenance procedures

Electrical equipment should be installed, operated, serviced, and maintained only by qualified personnel.

No responsibility is assumed by Schneider Electric for any arising out of the use of this material.

A qualified person is one who has skills and knowledge related to the construction and operation of electrical equipment and its installation, and has received safety training to recognize and avoid the hazards involved.

The frequency and the level of the maintenance depend of the criticality of the application and the environmental conditions.

These recommendations regard the busbar trunking system. For all devices fitted in tap-off units, the manufacturer's recommendations must be complied with.

#### Every year inspect the external appearance of busbar trunking lengths, accessories and supports.

Check if there is no:

- deformation, damage or dirt
- dislocation, bending, misalignment and other abnormality of the connecting covers, hangers and plug-in units
- junction blocks or terminals discoloured, corroded or pitted, or show signs it has been exposed to high temperatures
- change in the environment that can affect the busway operation such as water, moisture, high temperature, corrosive gas, immoderate vibration, dust, air circulation, new hot air source.

#### Every year inspect the external appearance of tap-off units.

- Remove dust, water and oil deposits, and all other conductive bodies from the sensitive zones.

The contact between busbar trunking and tap-off boxes does not need specific maintenance: Busbar trunking contacts consist of sprung silver plated contact jaws to ensure optimum contact quality.

#### In event of electrical default, fire, water leakage, earthquake or any important change an immediate inspection must be carried out.

Critical applications means: needs of high level of continuity of service such as hospital secured power distribution, data centre IT or cooling power supply or with a high load factor.

Unfavourable conditions are: high ambient temperature, high level of humidity, environment with a lot of dust, vibrations or similar.

#### Every year achieve a basic maintenance as described in the above chapter.

#### Every year check is there is no abnormal temperature.

- If the busbar trunking is accessible, carry out infrared temperature measurements on all the electrical connections ( junction blocks, terminal connections, tap-off units).
- If the busbar trunking is not accessible, install a thermal monitoring system which will communicate temperatures to a remote supervision.

These operations are relevant only if the busbar trunking has reached a stabilized temperature and if the measure of current has been done.

#### Notice

A periodic thermal monitoring allows tracking and detecting abnormal drifts. In case of abnormal results, check with a torque wrench, all the connections.

Type	Torque (N.m)
Junction block bolts	60 ± 10%

If these values decrease significantly over time, consult Schneider Electric for a deeper analysis.

If needed concerned material must be replaced with new factory mounted products. Consult your local Schneider Electric office for all replacements.

Before re-energising the busbar trunking, carry out an insulation resistance test in compliance with the instructions given in the "Testing and commissioning procedure" section.

After having performed all the necessary inspections and repairs mentioned above, it may be desirable to carry out infrared temperature measurements on all the electrical connections.



DB409482

## Recycling busbar trunking



**Example:** 1 kg of PVC generates 1 kg of waste.

Canalis busbar trunking can be reused. Canalis busbar trunking is designed for a long service life and can easily be dismantled, cleaned and reused.

All packaging materials can be recycled (cardboard or recyclable polyethylene film).

All Canalis products are designed for safe end-of-life recycling. PVC, on the other hand, requires neutralisation of the hydrochloric acid produced using lime and generates dioxins that are extremely toxic.

### Canalis helps conserve natural resources

The depletion of raw materials (copper, plastics, etc.) is one of our ongoing concerns.

For this reason, we have optimised the used of all materials used to make our busbar trunking.

- Reduction of dangerous or polluting materials. We design our products to meet future European directives.
- Reduction in the weight of insulating materials.
- Reduction in the use of plastics for improved fire performance: less energy released during combustion, thereby limiting propagation and facilitating extinction (lower calorific value).

A

B

C

D

E

F

G

## Index of catalogue numbers

Cat. no.	Designations	Pages
<b>13000</b>		
13940	BLANKING PLATES, SET OF 10X5 MODULES FORR KAEDRA	122
<b>30000</b>		
33596	ARC-CHUTE COVER, FIXED NS, 3P	76
33597	ARC-CHUTE COVER, FIXED NS, 4P	76
<b>40000</b>		
47335	ARC-CHUTE COVER, FIXED NT, 3P	76
47336	ARC-CHUTE COVER, FIXED NT, 4P	76
<b>80000</b>		
87800	DBA 115 INSTALLATION KIT FOR KT BBT 800/4000A TDC	77
87801	DBA 115 INSTALLATION KIT FOR KT BBT 800/3200A RC	77
87808	SPECIAL TIGHTENING WRENCH BIT	77
<b>KHO</b>		
KH025SD541	KH BOX PLUG IN 3L N PE NSX250	135
KH025SD551	KH BOX PLUG IN 3L PEN NSX250	135
KH040SD9502	KH BOX PLUG IN 3L PEN SECT PEHLA 400 T2	138
KH040ZA07	CONNECTING BOX FOR KH040SD9502	138
KH063SD541	KH BOX PLUG IN 3L N PE NSX630	135
KH063SD551	KH BOX PLUG IN 3L PEN NSX630	135
KH063SD9502	KH BOX PLUG IN 3L PEN SECT PEHLA 630 T3	138
KH063ZA07	CONNECTING PLATE FOR KH063SD9502	138
<b>KHB</b>		
KHB0250SE4	KH PLUGIN 250A FUS 3LN ADV L & R	136
KHB0250SE5	KH PLUGIN 250A FUS 3LPEN ADV L & R	136
KHB0630SE4L	KH PLUGIN 630A FUS 3LN ADV L	137
KHB0630SE4R	KH PLUGIN 630A FUS 3LN ADV R	137
KHB0630SE5L	KH PLUGIN 630A FUS 3LPEN ADV L	137
KHB0630SE5R	KH PLUGIN 630A FUS 3LPEN ADV R	137
<b>KSB</b>		
KSB25SD4	TAP-OFF UNIT 25 A FUSE E27	117
KSB25SD5	TAP-OFF UNIT 25 A FUSE E27	117
KSB32SG4	CONNECTOR 32 A FUSE BS88A1	121
KSB50SF4	TAP-OFF UNIT 50 A FUSE 14X51	115
KSB50SF5	TAP-OFF UNIT 50 A FUSE 14X51	115
KSB50SN4	TAP-OFF UNIT 50 A FUSE E18	117
KSB50SN5	TAP-OFF UNIT 50 A FUSE E18	117
KSB63SD4	TAP-OFF UNIT 63 A FUSE E33	117
KSB63SD5	TAP-OFF UNIT 63 A FUSE E33	117
KSB63SM48	TAP-OFF UNIT 63 A 8 MODULES	110
KSB63SM58	TAP-OFF UNIT 63 A 8 MODULES	110
KSB80SG4	TAP-OFF UNIT 80 A FUSE BS88A1	121
KSB100SE4	TAP-OFF UNIT 100 A FUSE T00	116, 118
KSB100SE5	TAP-OFF UNIT 100 A FUSE T00	116, 118
KSB100SF4	TAP-OFF UNIT 100 A FUSE 22X58	115
KSB100SF5	TAP-OFF UNIT 100 A FUSE 22X58	115
KSB100SM412	TAP-OFF UNIT 100 A 12 MODULES	110
KSB100SM512	TAP-OFF UNIT 100 A 12 MODULES	110
KSB160DC4	TAP-OFF UNIT 160 A COMPACT NS	112
KSB160DC5	TAP-OFF UNIT 160 A COMPACT NS	112
KSB160SE4	TAP-OFF UNIT 160 A FUSE T00	116, 118
KSB160SE5	TAP-OFF UNIT 160 A FUSE T00	116, 118
KSB160SF4	TAP-OFF UNIT 160 A FUSE T0	116
KSB160SF5	TAP-OFF UNIT 160 A FUSE T0	116

Cat. no.	Designations	Pages
KSB160SG4	TAP-OFF UNIT 160 A FUSE BS88	121
KSB160SM413	TAP-OFF UNIT NG 160 A	111
KSB160SM513	TAP-OFF UNIT NG 160 A	111
KSB250DC4	TAP-OFF UNIT 250 A COMPACT NS	112
KSB250DC4TRE	TAP-OFF UNIT 250 A COMPACT NS TRE	113
KSB250DC5	TAP-OFF UNIT 250 A COMPACT NS	112
KSB250DC5TRE	TAP-OFF UNIT 250 A COMPACT NS TRE	113
KSB250SE4	TAP-OFF UNIT 250 A FUSE T1	116, 118
KSB250SE5	TAP-OFF UNIT 250 A FUSE T1	116, 118
KSB400DC4	TAP-OFF UNIT 400 A COMPACT NS	112
KSB400DC4TRE	TAP-OFF UNIT 400 A COMPACT NS TRE	113
KSB400DC5	TAP-OFF UNIT 400 A COMPACT NS	112
KSB400DC5TRE	TAP-OFF UNIT 400 A COMPACT NS TRE	113
KSB400SE4	TAP-OFF UNIT 400 A FUSE T2	116, 118
KSB400SE5	TAP-OFF UNIT 400 A FUSE T2	116, 118
KSB400ZC1	TAP-OFF UNIT DOOR MICROSWITCH 400 A	122
<b>KTA0800</b>		
KTA0800CP31	KT 3X800AL FLAT EDGEWISE N1	68
KTA0800CP32	KT 3X800AL FLAT EDGEWISE N2	68
KTA0800CP33	KT 3X800AL FLAT EDGEWISE N3	68
KTA0800CP34	KT 3X800AL FLAT EDGEWISE N4	68
KTA0800CP41	KT 4X800AL FLAT EDGEWISE N1	68
KTA0800CP42	KT 4X800AL FLAT EDGEWISE N2	68
KTA0800CP43	KT 4X800AL FLAT EDGEWISE N3	68
KTA0800CP44	KT 4X800AL FLAT EDGEWISE N4	68
KTA0800CP51	KT 5X800AL FLAT EDGEWISE N1	68
KTA0800CP52	KT 5X800AL FLAT EDGEWISE N2	68
KTA0800CP53	KT 5X800AL FLAT EDGEWISE N3	68
KTA0800CP54	KT 5X800AL FLAT EDGEWISE N4	68
KTA0800CP71	KT 5X800AL FLAT EDGEWISE N1	68
KTA0800CP72	KT 5X800AL FLAT EDGEWISE N2	68
KTA0800CP73	KT 5X800AL FLAT EDGEWISE N3	68
KTA0800CP74	KT 5X800AL FLAT EDGEWISE N4	68
KTA0800DB310	KT 3X800AL EXPANSION UNIT	56
KTA0800DB410	KT 4X800AL EXPANSION UNIT	56
KTA0800DB510	KT 5X800AL EXPANSION UNIT	56
KTA0800DB710	KT 5X800AL EXPANSION UNIT	56
KTA0800EB320	KT 3X800AL BOLT ON LENGTH 2M	52
KTA0800EB340	KT 3X800AL BOLT ON LENGTH 4M	52
KTA0800EB420	KT 4X800AL BOLT ON LENGTH 2M	52
KTA0800EB440	KT 4X800AL BOLT ON LENGTH 4M	52
KTA0800EB520	KT 5X800AL BOLT ON LENGTH 2M	52
KTA0800EB540	KT 5X800AL BOLT ON LENGTH 4M	52
KTA0800EB720	KT 5X800AL BOLT ON LENGTH 2M	52
KTA0800EB740	KT 5X800AL BOLT ON LENGTH 4M	52
KTA0800ED3201	KT 1X800AL PLUG-IN LENGTH 2M	50
KTA0800ED3203	KT 3X800AL PLUG-IN LENGTH 2M	50
KTA0800ED3301	KT 1X800AL PLUG-IN LENGTH	50
KTA0800ED3302	KT 2X800AL PLUG-IN LENGTH	50
KTA0800ED3351	KT 1X800AL PLUG-IN LENGTH	50
KTA0800ED3353	KT 3X800AL PLUG-IN LENGTH	50
KTA0800ED3403	KT 3X800AL PLUG-IN LENGTH 4M	50
KTA0800ED4201	KT 1X800AL PLUG-IN LENGTH 2M	50
KTA0800ED4203	KT 4X800AL PLUG-IN LENGTH 2M	50
KTA0800ED4301	KT 1X800AL PLUG-IN LENGTH	50
KTA0800ED4302	KT 2X800AL PLUG-IN LENGTH	50
KTA0800ED4351	KT 1X800AL PLUG-IN LENGTH	50
KTA0800ED4353	KT 3X800AL PLUG-IN LENGTH	50
KTA0800ED4403	KT 4X800AL PLUG-IN LENGTH 4M	50
KTA0800ED5201	KT 1X800AL PLUG-IN LENGTH 2M	50
KTA0800ED5203	KT 5X800AL PLUG-IN LENGTH 2M	50
KTA0800ED5301	KT 1X800AL PLUG-IN LENGTH	50

## Index of catalogue numbers

Cat. no.	Designations	Pages	Cat. no.	Designations	Pages
KTA0800ED5302	KT 2X800AL PLUG-IN LENGTH	50	KTA0800ER76	KT 5X800AL FEED UNIT ER N6	81
KTA0800ED5351	KT 1X800AL PLUG-IN LENGTH	50	KTA0800ER77	KT 5X800AL FEED UNIT ER N7	85
KTA0800ED5353	KT 3X800AL PLUG-IN LENGTH	50	KTA0800ET31A	KT 3X800AL FEEDER LENGTH	50
KTA0800ED5403	KT 5X800AL PLUG-IN LENGTH 4M	50	KTA0800ET320	KT 3X800AL FEEDER LENGTH 2M	50
KTA0800ED7201	KT 1X800AL PLUG-IN LENGTH 2M	50	KTA0800ET32B	KT 3X800AL FEEDER LENGTH	50
KTA0800ED7203	KT 5X800AL PLUG-IN LENGTH 2M	50	KTA0800ET32C	KT 3X800AL FEEDER LENGTH	50
KTA0800ED7301	KT 1X800AL PLUG-IN LENGTH	50	KTA0800ET33D	KT 3X800AL FEEDER LENGTH	50
KTA0800ED7302	KT 2X800AL PLUG-IN LENGTH	50	KTA0800ET33E	KT 3X800AL FEEDER LENGTH	50
KTA0800ED7351	KT 1X800AL PLUG-IN LENGTH	50	KTA0800ET33F	KT 3X800AL FEEDER LENGTH	50
KTA0800ED7353	KT 3X800AL PLUG-IN LENGTH	50	KTA0800ET340	KT 3X800AL FEEDER LENGTH 4M	50
KTA0800ED7403	KT 5X800AL PLUG-IN LENGTH 4M	50	KTA0800ET41A	KT 4X800AL FEEDER LENGTH	50
KTA0800EH320	KT 3X800AL KH PLUG-IN LENGTH 2M	53	KTA0800ET420	KT 4X800AL FEEDER LENGTH 2M	50
KTA0800EH340	KT 3X800AL KH PLUG-IN LENGTH 4M	53	KTA0800ET42B	KT 4X800AL FEEDER LENGTH	50
KTA0800EH420	KT 4X800AL KH PLUG-IN LENGTH 2M	53	KTA0800ET42C	KT 4X800AL FEEDER LENGTH	50
KTA0800EH440	KT 4X800AL KH PLUG-IN LENGTH 4M	53	KTA0800ET43D	KT 4X800AL FEEDER LENGTH	50
KTA0800EH520	KT 5X800AL KH PLUG-IN LENGTH 2M	53	KTA0800ET43E	KT 4X800AL FEEDER LENGTH	50
KTA0800EH540	KT 5X800AL KH PLUG-IN LENGTH 4M	53	KTA0800ET43F	KT 4X800AL FEEDER LENGTH	50
KTA0800EL31	KT 3X800AL FEED UNIT EL N1	92	KTA0800ET440	KT 4X800AL FEEDER LENGTH 4M	50
KTA0800EL32	KT 3X800AL FEED UNIT EL N2	92	KTA0800ET51A	KT 5X800AL FEEDER LENGTH	50
KTA0800EL33	KT 3X800AL FEED UNIT EL N3	94	KTA0800ET520	KT 5X800AL FEEDER LENGTH 2M	50
KTA0800EL34	KT 3X800AL FEED UNIT EL N4	94	KTA0800ET52B	KT 5X800AL FEEDER LENGTH	50
KTA0800EL35	KT 3X800AL FEED UNIT EL N5	95	KTA0800ET52C	KT 5X800AL FEEDER LENGTH	50
KTA0800EL41	KT 4X800AL FEED UNIT EL N1	92	KTA0800ET53D	KT 5X800AL FEEDER LENGTH	50
KTA0800EL42	KT 4X800AL FEED UNIT EL N2	92	KTA0800ET53E	KT 5X800AL FEEDER LENGTH	50
KTA0800EL43	KT 4X800AL FEED UNIT EL N3	94	KTA0800ET53F	KT 5X800AL FEEDER LENGTH	50
KTA0800EL44	KT 4X800AL FEED UNIT EL N4	94	KTA0800ET540	KT 5X800AL FEEDER LENGTH 4M	50
KTA0800EL45	KT 4X800AL FEED UNIT EL N5	95	KTA0800ET71A	KT 5X800AL FEEDER LENGTH	50
KTA0800EL51	KT 5X800AL FEED UNIT EL N1	92	KTA0800ET720	KT 5X800AL FEEDER LENGTH 2M	50
KTA0800EL52	KT 5X800AL FEED UNIT EL N2	92	KTA0800ET72B	KT 5X800AL FEEDER LENGTH	50
KTA0800EL53	KT 5X800AL FEED UNIT EL N3	94	KTA0800ET72C	KT 5X800AL FEEDER LENGTH	50
KTA0800EL54	KT 5X800AL FEED UNIT EL N4	94	KTA0800ET73D	KT 5X800AL FEEDER LENGTH	50
KTA0800EL55	KT 5X800AL FEED UNIT EL N5	95	KTA0800ET73E	KT 5X800AL FEEDER LENGTH	50
KTA0800EL71	KT 5X800AL FEED UNIT EL N1	92	KTA0800ET73F	KT 5X800AL FEEDER LENGTH	50
KTA0800EL72	KT 5X800AL FEED UNIT EL N2	92	KTA0800ET740	KT 5X800AL FEEDER LENGTH 4M	50
KTA0800EL73	KT 5X800AL FEED UNIT EL N3	94	KTA0800FC3A	KT 3X800AL EDGEWISE ELBOW	73
KTA0800EL74	KT 5X800AL FEED UNIT EL N4	94	KTA0800FC3B	KT 3X800AL EDGEWISE ELBOW	73
KTA0800EL75	KT 5X800AL FEED UNIT EL N5	95	KTA0800FC3D	KT 3X800AL EDGEWISE ELBOW	73
KTA0800ER31	KT 3X800AL FEED UNIT ER N1	79	KTA0800FC3E	KT 3X800AL EDGEWISE ELBOW	73
KTA0800ER32	KT 3X800AL FEED UNIT ER N2	79	KTA0800FC4A	KT 4X800AL EDGEWISE ELBOW	73
KTA0800ER33	KT 3X800AL FEED UNIT ER N3	80	KTA0800FC4B	KT 4X800AL EDGEWISE ELBOW	73
KTA0800ER34	KT 3X800AL FEED UNIT ER N4	80	KTA0800FC4D	KT 4X800AL EDGEWISE ELBOW	73
KTA0800ER35	KT 3X800AL FEED UNIT ER N5	81	KTA0800FC4E	KT 4X800AL EDGEWISE ELBOW	73
KTA0800ER36	KT 3X800AL FEED UNIT ER N6	81	KTA0800FC5A	KT 5X800AL EDGEWISE ELBOW	73
KTA0800ER37	KT 3X800AL FEED UNIT ER N7	85	KTA0800FC5B	KT 5X800AL EDGEWISE ELBOW	73
KTA0800ER41	KT 4X800AL FEED UNIT ER N1	79	KTA0800FC5D	KT 5X800AL EDGEWISE ELBOW	73
KTA0800ER42	KT 4X800AL FEED UNIT ER N2	79	KTA0800FC5E	KT 5X800AL EDGEWISE ELBOW	73
KTA0800ER43	KT 4X800AL FEED UNIT ER N3	80	KTA0800FC7A	KT 5X800AL EDGEWISE ELBOW	73
KTA0800ER44	KT 4X800AL FEED UNIT ER N4	80	KTA0800FC7B	KT 5X800AL EDGEWISE ELBOW	73
KTA0800ER45	KT 4X800AL FEED UNIT ER N5	81	KTA0800FC7D	KT 5X800AL EDGEWISE ELBOW	73
KTA0800ER46	KT 4X800AL FEED UNIT ER N6	81	KTA0800FC7E	KT 5X800AL EDGEWISE ELBOW	73
KTA0800ER47	KT 4X800AL FEED UNIT ER N7	85	KTA0800FJ3	KT 3X800AL JUNCTION BLOC FIRE RATED	71
KTA0800ER51	KT 5X800AL FEED UNIT ER N1	79	KTA0800FJ4	KT 4X800AL JUNCTION BLOC FIRE RATED	71
KTA0800ER52	KT 5X800AL FEED UNIT ER N2	79	KTA0800FJ5	KT 5X800AL JUNCTION BLOC FIRE RATED	71
KTA0800ER53	KT 5X800AL FEED UNIT ER N3	80	KTA0800FJ6	KT 4X800AL JUNCTION BLOC FIRE RATED	71
KTA0800ER54	KT 5X800AL FEED UNIT ER N4	80	KTA0800FJ7	KT 5X800AL JUNCTION BLOC FIRE RATED	71
KTA0800ER55	KT 5X800AL FEED UNIT ER N5	81	KTA0800FP3A1	KT 3X800AL FLAT ELBOW N1 FIRE	72
KTA0800ER56	KT 5X800AL FEED UNIT ER N6	81	KTA0800FP3A2	KT 3X800AL FLAT ELBOW N2 FIRE	72
KTA0800ER57	KT 5X800AL FEED UNIT ER N7	85	KTA0800FP3B1	KT 3X800AL FLAT ELBOW N1 FIRE	72
KTA0800ER71	KT 5X800AL FEED UNIT ER N1	79	KTA0800FP3B2	KT 3X800AL FLAT ELBOW N2 FIRE	72
KTA0800ER72	KT 5X800AL FEED UNIT ER N2	79	KTA0800FP3D1	KT 3X800AL FLAT ELBOW N1 FIRE	72
KTA0800ER73	KT 5X800AL FEED UNIT ER N3	80	KTA0800FP3D2	KT 3X800AL FLAT ELBOW N2 FIRE	72
KTA0800ER74	KT 5X800AL FEED UNIT ER N4	80	KTA0800FP3E1	KT 3X800AL FLAT ELBOW N1 FIRE	72
KTA0800ER75	KT 5X800AL FEED UNIT ER N5	81	KTA0800FP3E2	KT 3X800AL FLAT ELBOW N2 FIRE	72

A

B

C

D

E

F

G

## Index of catalogue numbers

Cat. no.	Designations	Pages
<b>KTA0800FP4A1</b>	KT 4X800AL FLAT ELBOW N1 FIRE	72
<b>KTA0800FP4A2</b>	KT 4X800AL FLAT ELBOW N2 FIRE	72
<b>KTA0800FP4B1</b>	KT 4X800AL FLAT ELBOW N1 FIRE	72
<b>KTA0800FP4B2</b>	KT 4X800AL FLAT ELBOW N2 FIRE	72
<b>KTA0800FP4D1</b>	KT 4X800AL FLAT ELBOW N1 FIRE	72
<b>KTA0800FP4D2</b>	KT 4X800AL FLAT ELBOW N2 FIRE	72
<b>KTA0800FP4E1</b>	KT 4X800AL FLAT ELBOW N1 FIRE	72
<b>KTA0800FP4E2</b>	KT 4X800AL FLAT ELBOW N2 FIRE	72
<b>KTA0800FP5A1</b>	KT 5X800AL FLAT ELBOW N1 FIRE	72
<b>KTA0800FP5A2</b>	KT 5X800AL FLAT ELBOW N2 FIRE	72
<b>KTA0800FP5B1</b>	KT 5X800AL FLAT ELBOW N1 FIRE	72
<b>KTA0800FP5B2</b>	KT 5X800AL FLAT ELBOW N2 FIRE	72
<b>KTA0800FP5D1</b>	KT 5X800AL FLAT ELBOW N1 FIRE	72
<b>KTA0800FP5D2</b>	KT 5X800AL FLAT ELBOW N2 FIRE	72
<b>KTA0800FP5E1</b>	KT 5X800AL FLAT ELBOW N1 FIRE	72
<b>KTA0800FP5E2</b>	KT 5X800AL FLAT ELBOW N2 FIRE	72
<b>KTA0800FP7A1</b>	KT 5X800AL FLAT ELBOW N1 FIRE	72
<b>KTA0800FP7A2</b>	KT 5X800AL FLAT ELBOW N2 FIRE	72
<b>KTA0800FP7B1</b>	KT 5X800AL FLAT ELBOW N1 FIRE	72
<b>KTA0800FP7B2</b>	KT 5X800AL FLAT ELBOW N2 FIRE	72
<b>KTA0800FP7D1</b>	KT 5X800AL FLAT ELBOW N1 FIRE	72
<b>KTA0800FP7D2</b>	KT 5X800AL FLAT ELBOW N2 FIRE	72
<b>KTA0800FP7E1</b>	KT 5X800AL FLAT ELBOW N1 FIRE	72
<b>KTA0800FP7E2</b>	KT 5X800AL FLAT ELBOW N2 FIRE	72
<b>KTA0800FT31A</b>	KT 3X800AL FEEDER LENGTH FIRE	70
<b>KTA0800FT320</b>	KT 3X800AL FEEDER LENGTH FIRE 2M	70
<b>KTA0800FT32B</b>	KT 3X800AL FEEDER LENGTH FIRE	70
<b>KTA0800FT32C</b>	KT 3X800AL FEEDER LENGTH FIRE	70
<b>KTA0800FT33D</b>	KT 3X800AL FEEDER LENGTH FIRE	70
<b>KTA0800FT33E</b>	KT 3X800AL FEEDER LENGTH FIRE	70
<b>KTA0800FT33F</b>	KT 3X800AL FEEDER LENGTH FIRE	70
<b>KTA0800FT340</b>	KT 3X800AL FEEDER LENGTH FIRE 4M	70
<b>KTA0800FT41A</b>	KT 4X800AL FEEDER LENGTH FIRE	70
<b>KTA0800FT420</b>	KT 4X800AL FEEDER LENGTH FIRE 2M	70
<b>KTA0800FT42B</b>	KT 4X800AL FEEDER LENGTH FIRE	70
<b>KTA0800FT42C</b>	KT 4X800AL FEEDER LENGTH FIRE	70
<b>KTA0800FT43D</b>	KT 4X800AL FEEDER LENGTH FIRE	70
<b>KTA0800FT43E</b>	KT 4X800AL FEEDER LENGTH FIRE	70
<b>KTA0800FT43F</b>	KT 4X800AL FEEDER LENGTH FIRE	70
<b>KTA0800FT440</b>	KT 4X800AL FEEDER LENGTH FIRE 4M	70
<b>KTA0800FT51A</b>	KT 5X800AL FEEDER LENGTH FIRE	70
<b>KTA0800FT520</b>	KT 5X800AL FEEDER LENGTH FIRE 2M	70
<b>KTA0800FT52B</b>	KT 5X800AL FEEDER LENGTH FIRE	70
<b>KTA0800FT52C</b>	KT 5X800AL FEEDER LENGTH FIRE	70
<b>KTA0800FT53D</b>	KT 5X800AL FEEDER LENGTH FIRE	70
<b>KTA0800FT53E</b>	KT 5X800AL FEEDER LENGTH FIRE	70
<b>KTA0800FT53F</b>	KT 5X800AL FEEDER LENGTH FIRE	70
<b>KTA0800FT540</b>	KT 5X800AL FEEDER LENGTH FIRE 4M	70
<b>KTA0800FT71A</b>	KT 5X800AL FEEDER LENGTH FIRE	70
<b>KTA0800FT720</b>	KT 5X800AL FEEDER LENGTH FIRE 2M	70
<b>KTA0800FT72B</b>	KT 5X800AL FEEDER LENGTH FIRE	70
<b>KTA0800FT72C</b>	KT 5X800AL FEEDER LENGTH FIRE	70
<b>KTA0800FT73D</b>	KT 5X800AL FEEDER LENGTH FIRE	70
<b>KTA0800FT73E</b>	KT 5X800AL FEEDER LENGTH FIRE	70
<b>KTA0800FT73F</b>	KT 5X800AL FEEDER LENGTH FIRE	70
<b>KTA0800FT740</b>	KT 5X800AL FEEDER LENGTH FIRE 4M	70
<b>KTA0800LC3A</b>	KT 3X800AL EDGEWISE ELBOW	61
<b>KTA0800LC3B</b>	KT 3X800AL EDGEWISE ELBOW	61
<b>KTA0800LC3D</b>	KT 3X800AL EDGEWISE ELBOW	61
<b>KTA0800LC3E</b>	KT 3X800AL EDGEWISE ELBOW	61
<b>KTA0800LC4A</b>	KT 4X800AL EDGEWISE ELBOW	61
<b>KTA0800LC4B</b>	KT 4X800AL EDGEWISE ELBOW	61
<b>KTA0800LC4D</b>	KT 4X800AL EDGEWISE ELBOW	61

Cat. no.	Designations	Pages
<b>KTA0800LC4E</b>	KT 4X800AL EDGEWISE ELBOW	61
<b>KTA0800LC5A</b>	KT 5X800AL EDGEWISE ELBOW	61
<b>KTA0800LC5B</b>	KT 5X800AL EDGEWISE ELBOW	61
<b>KTA0800LC5D</b>	KT 5X800AL EDGEWISE ELBOW	61
<b>KTA0800LC5E</b>	KT 5X800AL EDGEWISE ELBOW	61
<b>KTA0800LC7A</b>	KT 5X800AL EDGEWISE ELBOW	61
<b>KTA0800LC7B</b>	KT 5X800AL EDGEWISE ELBOW	61
<b>KTA0800LC7D</b>	KT 5X800AL EDGEWISE ELBOW	61
<b>KTA0800LC7E</b>	KT 5X800AL EDGEWISE ELBOW	61
<b>KTA0800LP3A1</b>	KT 3X800AL FLAT ELBOW N1	60
<b>KTA0800LP3A2</b>	KT 3X800AL FLAT ELBOW N2	60
<b>KTA0800LP3B1</b>	KT 3X800AL FLAT ELBOW N1	60
<b>KTA0800LP3B2</b>	KT 3X800AL FLAT ELBOW N2	60
<b>KTA0800LP3C1</b>	KT 3X800AL FLAT ELBOW N1	61
<b>KTA0800LP3C2</b>	KT 3X800AL FLAT ELBOW N2	61
<b>KTA0800LP3D1</b>	KT 3X800AL FLAT ELBOW N1	60
<b>KTA0800LP3D2</b>	KT 3X800AL FLAT ELBOW N2	60
<b>KTA0800LP3E1</b>	KT 3X800AL FLAT ELBOW N1	60
<b>KTA0800LP3E2</b>	KT 3X800AL FLAT ELBOW N2	60
<b>KTA0800LP4A1</b>	KT 4X800AL FLAT ELBOW N1	60
<b>KTA0800LP4A2</b>	KT 4X800AL FLAT ELBOW N2	60
<b>KTA0800LP4B1</b>	KT 4X800AL FLAT ELBOW N1	60
<b>KTA0800LP4B2</b>	KT 4X800AL FLAT ELBOW N2	60
<b>KTA0800LP4C1</b>	KT 4X800AL FLAT ELBOW N1	61
<b>KTA0800LP4C2</b>	KT 4X800AL FLAT ELBOW N2	61
<b>KTA0800LP4D1</b>	KT 4X800AL FLAT ELBOW N1	60
<b>KTA0800LP4D2</b>	KT 4X800AL FLAT ELBOW N2	60
<b>KTA0800LP4E1</b>	KT 4X800AL FLAT ELBOW N1	60
<b>KTA0800LP4E2</b>	KT 4X800AL FLAT ELBOW N2	60
<b>KTA0800LP5A1</b>	KT 5X800AL FLAT ELBOW N1	60
<b>KTA0800LP5A2</b>	KT 5X800AL FLAT ELBOW N2	60
<b>KTA0800LP5B1</b>	KT 5X800AL FLAT ELBOW N1	60
<b>KTA0800LP5B2</b>	KT 5X800AL FLAT ELBOW N2	60
<b>KTA0800LP5C1</b>	KT 5X800AL FLAT ELBOW N1	61
<b>KTA0800LP5C2</b>	KT 5X800AL FLAT ELBOW N2	61
<b>KTA0800LP5D1</b>	KT 5X800AL FLAT ELBOW N1	60
<b>KTA0800LP5D2</b>	KT 5X800AL FLAT ELBOW N2	60
<b>KTA0800LP5E1</b>	KT 5X800AL FLAT ELBOW N1	60
<b>KTA0800LP5E2</b>	KT 5X800AL FLAT ELBOW N2	60
<b>KTA0800LP7A1</b>	KT 5X800AL FLAT ELBOW N1	60
<b>KTA0800LP7A2</b>	KT 5X800AL FLAT ELBOW N2	60
<b>KTA0800LP7B1</b>	KT 5X800AL FLAT ELBOW N1	60
<b>KTA0800LP7B2</b>	KT 5X800AL FLAT ELBOW N2	60
<b>KTA0800LP7C1</b>	KT 5X800AL FLAT ELBOW N1	61
<b>KTA0800LP7C2</b>	KT 5X800AL FLAT ELBOW N2	61
<b>KTA0800LP7D1</b>	KT 5X800AL FLAT ELBOW N1	60
<b>KTA0800LP7D2</b>	KT 5X800AL FLAT ELBOW N2	60
<b>KTA0800LP7E1</b>	KT 5X800AL FLAT ELBOW N1	60
<b>KTA0800LP7E2</b>	KT 5X800AL FLAT ELBOW N2	60
<b>KTA0800TC3</b>	KT 3X800AL TEE ON EDGE	65
<b>KTA0800TC4</b>	KT 4X800AL TEE ON EDGE	65
<b>KTA0800TC5</b>	KT 5X800AL TEE ON EDGE	65
<b>KTA0800TC7</b>	KT 5X800AL TEE ON EDGE	65
<b>KTA0800TN410</b>	KT 4X800AL NEUTRAL PERMUTA	56
<b>KTA0800TN610</b>	KT 4X800AL NEUTRAL PERMUTA	56
<b>KTA0800TP410</b>	KT 4X800AL PHASES PERMUTA	56
<b>KTA0800TP610</b>	KT 4X800AL PHASES PERMUTA	56
<b>KTA0800YA3</b>	KT 3X800AL JUNCTION BLOC	58
<b>KTA0800YA4</b>	KT 4X800AL JUNCTION BLOC	58
<b>KTA0800YA5</b>	KT 5X800AL JUNCTION BLOC	58
<b>KTA0800YA6</b>	KT 4X800AL JUNCTION BLOC	58
<b>KTA0800YA7</b>	KT 5X800AL JUNCTION BLOC	58
<b>KTA0800ZC31</b>	KT 3X800AL EDGEWISE ZED N1	66

## Index of catalogue numbers

Cat. no.	Designations	Pages	Cat. no.	Designations	Pages
<b>KTA0800ZC32</b>	KT 3X800AL EDGEWISE ZED N2	66	<b>KTA1000ED7203</b>	KT 5X1000AL PLUG-IN LENGTH 2M	50
<b>KTA0800ZC41</b>	KT 4X800AL EDGEWISE ZED N1	66	<b>KTA1000ED7301</b>	KT 1X1000AL PLUG-IN LENGTH	50
<b>KTA0800ZC42</b>	KT 4X800AL EDGEWISE ZED N2	66	<b>KTA1000ED7302</b>	KT 2X1000AL PLUG-IN LENGTH	50
<b>KTA0800ZC51</b>	KT 5X800AL EDGEWISE ZED N1	66	<b>KTA1000ED7351</b>	KT 1X1000AL PLUG-IN LENGTH	50
<b>KTA0800ZC52</b>	KT 5X800AL EDGEWISE ZED N2	66	<b>KTA1000ED7353</b>	KT 3X1000AL PLUG-IN LENGTH	50
<b>KTA0800ZC71</b>	KT 5X800AL EDGEWISE ZED N1	66	<b>KTA1000ED7403</b>	KT 5X1000AL PLUG-IN LENGTH 4M	50
<b>KTA0800ZC72</b>	KT 5X800AL EDGEWISE ZED N2	66	<b>KTA1000EH320</b>	KT 3X1000AL KH PLUG-IN LENGTH 2M	53
<b>KTA0800ZP3</b>	KT 3X800AL ZED ON FLAT	66	<b>KTA1000EH340</b>	KT 3X1000AL KH PLUG-IN LENGTH 4M	53
<b>KTA0800ZP4</b>	KT 4X800AL ZED ON FLAT	66	<b>KTA1000EH420</b>	KT 4X1000AL KH PLUG-IN LENGTH 2M	53
<b>KTA0800ZP5</b>	KT 5X800AL ZED ON FLAT	66	<b>KTA1000EH440</b>	KT 4X1000AL KH PLUG-IN LENGTH 4M	53
<b>KTA0800ZP7</b>	KT 5X800AL ZED ON FLAT	66	<b>KTA1000EH520</b>	5X1000AL KH PLUG-IN LENGTH 2M	53
<b>KTA1000</b>			<b>KTA1000EH540</b>	5X1000AL KH PLUG-IN LENGTH 4M	53
<b>KTA1000CP31</b>	KT 3X1000AL FLAT EDGEWISE N1	68	<b>KTA1000EL31</b>	KT 3X1000AL FEED UNIT EL N1	92
<b>KTA1000CP32</b>	KT 3X1000AL FLAT EDGEWISE N2	68	<b>KTA1000EL32</b>	KT 3X1000AL FEED UNIT EL N2	92
<b>KTA1000CP33</b>	KT 3X1000AL FLAT EDGEWISE N3	68	<b>KTA1000EL33</b>	KT 3X1000AL FEED UNIT EL N3	94
<b>KTA1000CP34</b>	KT 3X1000AL FLAT EDGEWISE N4	68	<b>KTA1000EL34</b>	KT 3X1000AL FEED UNIT EL N4	94
<b>KTA1000CP41</b>	KT 4X1000AL FLAT EDGEWISE N1	68	<b>KTA1000EL35</b>	KT 3X1000AL FEED UNIT EL N5	95
<b>KTA1000CP42</b>	KT 4X1000AL FLAT EDGEWISE N2	68	<b>KTA1000EL41</b>	KT 4X1000AL FEED UNIT EL N1	92
<b>KTA1000CP43</b>	KT 4X1000AL FLAT EDGEWISE N3	68	<b>KTA1000EL42</b>	KT 4X1000AL FEED UNIT EL N2	92
<b>KTA1000CP44</b>	KT 4X1000AL FLAT EDGEWISE N4	68	<b>KTA1000EL43</b>	KT 4X1000AL FEED UNIT EL N3	94
<b>KTA1000CP51</b>	KT 5X1000AL FLAT EDGEWISE N1	68	<b>KTA1000EL44</b>	KT 4X1000AL FEED UNIT EL N4	94
<b>KTA1000CP52</b>	KT 5X1000AL FLAT EDGEWISE N2	68	<b>KTA1000EL45</b>	KT 4X1000AL FEED UNIT EL N5	95
<b>KTA1000CP53</b>	KT 5X1000AL FLAT EDGEWISE N3	68	<b>KTA1000EL51</b>	KT 5X1000AL FEED UNIT EL N1	92
<b>KTA1000CP54</b>	KT 5X1000AL FLAT EDGEWISE N4	68	<b>KTA1000EL52</b>	KT 5X1000AL FEED UNIT EL N2	92
<b>KTA1000CP71</b>	KT 5X1000AL FLAT EDGEWISE N1	68	<b>KTA1000EL53</b>	KT 5X1000AL FEED UNIT EL N3	94
<b>KTA1000CP72</b>	KT 5X1000AL FLAT EDGEWISE N2	68	<b>KTA1000EL54</b>	KT 5X1000AL FEED UNIT EL N4	94
<b>KTA1000CP73</b>	KT 5X1000AL FLAT EDGEWISE N3	68	<b>KTA1000EL55</b>	KT 5X1000AL FEED UNIT EL N5	95
<b>KTA1000CP74</b>	KT 5X1000AL FLAT EDGEWISE N4	68	<b>KTA1000EL71</b>	KT 5X1000AL FEED UNIT EL N1	92
<b>KTA1000DB310</b>	KT 3X1000AL EXPANSION UNIT	56	<b>KTA1000EL72</b>	KT 5X1000AL FEED UNIT EL N2	92
<b>KTA1000DB410</b>	KT 4X1000AL EXPANSION UNIT	56	<b>KTA1000EL73</b>	KT 5X1000AL FEED UNIT EL N3	94
<b>KTA1000DB510</b>	KT 5X1000AL EXPANSION UNIT	56	<b>KTA1000EL74</b>	KT 5X1000AL FEED UNIT EL N4	94
<b>KTA1000DB710</b>	KT 5X1000AL EXPANSION UNIT	56	<b>KTA1000EL75</b>	KT 5X1000AL FEED UNIT EL N5	95
<b>KTA1000EB320</b>	KT 3X1000AL BOLT ON LENGTH 2M	52	<b>KTA1000ER31</b>	KT 3X1000AL FEED UNIT ER N1	79
<b>KTA1000EB340</b>	KT 3X1000AL BOLT ON LENGTH 4M	52	<b>KTA1000ER32</b>	KT 3X1000AL FEED UNIT ER N2	79
<b>KTA1000EB420</b>	KT 4X1000AL BOLT ON LENGTH 2M	52	<b>KTA1000ER33</b>	KT 3X1000AL FEED UNIT ER N3	80
<b>KTA1000EB440</b>	KT 4X1000AL BOLT ON LENGTH 4M	52	<b>KTA1000ER34</b>	KT 3X1000AL FEED UNIT ER N4	80
<b>KTA1000EB520</b>	KT 5X1000AL BOLT ON LENGTH 2M	52	<b>KTA1000ER35</b>	KT 3X1000AL FEED UNIT ER N5	81
<b>KTA1000EB540</b>	KT 5X1000AL BOLT ON LENGTH 4M	52	<b>KTA1000ER36</b>	KT 3X1000AL FEED UNIT ER N6	81
<b>KTA1000EB720</b>	KT 5X1000AL BOLT ON LENGTH 2M	52	<b>KTA1000ER37</b>	KT 3X1000AL FEED UNIT ER N7	85
<b>KTA1000EB740</b>	KT 5X1000AL BOLT ON LENGTH 4M	52	<b>KTA1000ER41</b>	KT 4X1000AL FEED UNIT ER N1	79
<b>KTA1000ED3201</b>	KT 1X1000AL PLUG-IN LENGTH 2M	50	<b>KTA1000ER42</b>	KT 4X1000AL FEED UNIT ER N2	79
<b>KTA1000ED3203</b>	KT 3X1000AL PLUG-IN LENGTH 2M	50	<b>KTA1000ER43</b>	KT 4X1000AL FEED UNIT ER N3	80
<b>KTA1000ED3301</b>	KT 1X1000AL PLUG-IN LENGTH	50	<b>KTA1000ER44</b>	KT 4X1000AL FEED UNIT ER N4	80
<b>KTA1000ED3302</b>	KT 2X1000AL PLUG-IN LENGTH	50	<b>KTA1000ER45</b>	KT 4X1000AL FEED UNIT ER N5	81
<b>KTA1000ED3351</b>	KT 1X1000AL PLUG-IN LENGTH	50	<b>KTA1000ER46</b>	KT 4X1000AL FEED UNIT ER N6	81
<b>KTA1000ED3353</b>	KT 3X1000AL PLUG-IN LENGTH	50	<b>KTA1000ER47</b>	KT 4X1000AL FEED UNIT ER N7	85
<b>KTA1000ED3403</b>	KT 3X1000AL PLUG-IN LENGTH 4M	50	<b>KTA1000ER51</b>	KT 5X1000AL FEED UNIT ER N1	79
<b>KTA1000ED4201</b>	KT 1X1000AL PLUG-IN LENGTH 2M	50	<b>KTA1000ER52</b>	KT 5X1000AL FEED UNIT ER N2	79
<b>KTA1000ED4203</b>	KT 4X1000AL PLUG-IN LENGTH 2M	50	<b>KTA1000ER53</b>	KT 5X1000AL FEED UNIT ER N3	80
<b>KTA1000ED4301</b>	KT 1X1000AL PLUG-IN LENGTH	50	<b>KTA1000ER54</b>	KT 5X1000AL FEED UNIT ER N4	80
<b>KTA1000ED4302</b>	KT 2X1000AL PLUG-IN LENGTH	50	<b>KTA1000ER55</b>	KT 5X1000AL FEED UNIT ER N5	81
<b>KTA1000ED4351</b>	KT 1X1000AL PLUG-IN LENGTH	50	<b>KTA1000ER56</b>	KT 5X1000AL FEED UNIT ER N6	81
<b>KTA1000ED4353</b>	KT 3X1000AL PLUG-IN LENGTH	50	<b>KTA1000ER57</b>	KT 5X1000AL FEED UNIT ER N7	85
<b>KTA1000ED4403</b>	KT 4X1000AL PLUG-IN LENGTH 4M	50	<b>KTA1000ER71</b>	KT 5X1000AL FEED UNIT ER N1	79
<b>KTA1000ED5201</b>	KT 1X1000AL PLUG-IN LENGTH 2M	50	<b>KTA1000ER72</b>	KT 5X1000AL FEED UNIT ER N2	79
<b>KTA1000ED5203</b>	KT 5X1000AL PLUG-IN LENGTH 2M	50	<b>KTA1000ER73</b>	KT 5X1000AL FEED UNIT ER N3	80
<b>KTA1000ED5301</b>	KT 1X1000AL PLUG-IN LENGTH	50	<b>KTA1000ER74</b>	KT 5X1000AL FEED UNIT ER N4	80
<b>KTA1000ED5302</b>	KT 2X1000AL PLUG-IN LENGTH	50	<b>KTA1000ER75</b>	KT 5X1000AL FEED UNIT ER N5	81
<b>KTA1000ED5351</b>	KT 1X1000AL PLUG-IN LENGTH	50	<b>KTA1000ER76</b>	KT 5X1000AL FEED UNIT ER N6	81
<b>KTA1000ED5353</b>	KT 3X1000AL PLUG-IN LENGTH	50	<b>KTA1000ER77</b>	KT 5X1000AL FEED UNIT ER N7	85
<b>KTA1000ED5403</b>	KT 5X1000AL PLUG-IN LENGTH 4M	50	<b>KTA1000ET31A</b>	KT 3X1000AL FEEDER LENGTH	50
<b>KTA1000ED7201</b>	KT 1X1000AL PLUG-IN LENGTH 2M	50	<b>KTA1000ET320</b>	KT 3X1000AL FEEDER LENGTH 2M	50
			<b>KTA1000ET32B</b>	KT 3X1000AL FEEDER LENGTH	50

## Index of catalogue numbers

Cat. no.	Designations	Pages	Cat. no.	Designations	Pages
<b>A</b>					
KTA1000ET32C	KT 3X1000AL FEEDER LENGTH	50	KTA1000FP4D2	KT 4X1000AL FLAT ELBOW N2 FIRE	72
KTA1000ET33D	KT 3X1000AL FEEDER LENGTH	50	KTA1000FP4E1	KT 4X1000AL FLAT ELBOW N1 FIRE	72
KTA1000ET33E	KT 3X1000AL FEEDER LENGTH	50	KTA1000FP4E2	KT 4X1000AL FLAT ELBOW N2 FIRE	72
KTA1000ET33F	KT 3X1000AL FEEDER LENGTH	50	KTA1000FP5A1	KT 5X1000AL FLAT ELBOW N1 FIRE	72
KTA1000ET340	KT 3X1000AL FEEDER LENGTH 4M	50	KTA1000FP5A2	KT 5X1000AL FLAT ELBOW N2 FIRE	72
<b>B</b>			KTA1000FP5B1	KT 5X1000AL FLAT ELBOW N1 FIRE	72
KTA1000ET41A	KT 4X1000AL FEEDER LENGTH	50	KTA1000FP5B2	KT 5X1000AL FLAT ELBOW N2 FIRE	72
KTA1000ET420	KT 4X1000AL FEEDER LENGTH 2M	50	KTA1000FP5D1	KT 5X1000AL FLAT ELBOW N1 FIRE	72
KTA1000ET42B	KT 4X1000AL FEEDER LENGTH	50	KTA1000FP5D2	KT 5X1000AL FLAT ELBOW N2 FIRE	72
KTA1000ET42C	KT 4X1000AL FEEDER LENGTH	50	KTA1000FP5E1	KT 5X1000AL FLAT ELBOW N1 FIRE	72
KTA1000ET43D	KT 4X1000AL FEEDER LENGTH	50	KTA1000FP5E2	KT 5X1000AL FLAT ELBOW N2 FIRE	72
KTA1000ET43E	KT 4X1000AL FEEDER LENGTH	50	KTA1000FP7A1	KT 5X1000AL FLAT ELBOW N1 FIRE	72
<b>C</b>			KTA1000FP7A2	KT 5X1000AL FLAT ELBOW N2 FIRE	72
KTA1000ET43F	KT 4X1000AL FEEDER LENGTH	50	KTA1000FP7B1	KT 5X1000AL FLAT ELBOW N1 FIRE	72
KTA1000ET440	KT 4X1000AL FEEDER LENGTH 4M	50	KTA1000FP7B2	KT 5X1000AL FLAT ELBOW N2 FIRE	72
KTA1000ET51A	KT 5X1000AL FEEDER LENGTH	50	KTA1000FP7D1	KT 5X1000AL FLAT ELBOW N1 FIRE	72
KTA1000ET520	KT 5X1000AL FEEDER LENGTH 2M	50	KTA1000FP7D2	KT 5X1000AL FLAT ELBOW N2 FIRE	72
KTA1000ET52B	KT 5X1000AL FEEDER LENGTH	50	KTA1000FP7E1	KT 5X1000AL FLAT ELBOW N1 FIRE	72
KTA1000ET52C	KT 5X1000AL FEEDER LENGTH	50	KTA1000FP7E2	KT 5X1000AL FLAT ELBOW N2 FIRE	72
KTA1000ET53D	KT 5X1000AL FEEDER LENGTH	50	KTA1000FP7E3	KT 5X1000AL FEEDER LENGTH FIRE	70
KTA1000ET53E	KT 5X1000AL FEEDER LENGTH	50	KTA1000FT31A	KT 3X1000AL FEEDER LENGTH FIRE 2M	70
KTA1000ET53F	KT 5X1000AL FEEDER LENGTH	50	KTA1000FT320	KT 3X1000AL FEEDER LENGTH FIRE	70
KTA1000ET540	KT 5X1000AL FEEDER LENGTH 4M	50	KTA1000FT32B	KT 3X1000AL FEEDER LENGTH FIRE	70
KTA1000ET71A	KT 5X1000AL FEEDER LENGTH	50	KTA1000FT32C	KT 3X1000AL FEEDER LENGTH FIRE	70
KTA1000ET720	KT 5X1000AL FEEDER LENGTH 2M	50	KTA1000FT33D	KT 3X1000AL FEEDER LENGTH FIRE	70
KTA1000ET72B	KT 5X1000AL FEEDER LENGTH	50	KTA1000FT33E	KT 3X1000AL FEEDER LENGTH FIRE	70
KTA1000ET72C	KT 5X1000AL FEEDER LENGTH	50	KTA1000FT33F	KT 3X1000AL FEEDER LENGTH FIRE	70
KTA1000ET73D	KT 5X1000AL FEEDER LENGTH	50	KTA1000FT340	KT 3X1000AL FEEDER LENGTH FIRE 4M	70
KTA1000ET73E	KT 5X1000AL FEEDER LENGTH	50	KTA1000FT41A	KT 4X1000AL FEEDER LENGTH FIRE	70
KTA1000ET73F	KT 5X1000AL FEEDER LENGTH	50	KTA1000FT420	KT 4X1000AL FEEDER LENGTH FIRE 2M	70
KTA1000ET740	KT 5X1000AL FEEDER LENGTH 4M	50	KTA1000FT42B	KT 4X1000AL FEEDER LENGTH FIRE	70
<b>D</b>			KTA1000FT42C	KT 4X1000AL FEEDER LENGTH FIRE	70
KTA1000FC3A	KT 3X1000AL EDGEWISE ELBOW	73	KTA1000FT43D	KT 4X1000AL FEEDER LENGTH FIRE	70
KTA1000FC3B	KT 3X1000AL EDGEWISE ELBOW	73	KTA1000FT43E	KT 4X1000AL FEEDER LENGTH FIRE	70
KTA1000FC3D	KT 3X1000AL EDGEWISE ELBOW	73	KTA1000FT43F	KT 4X1000AL FEEDER LENGTH FIRE	70
KTA1000FC3E	KT 3X1000AL EDGEWISE ELBOW	73	KTA1000FT440	KT 4X1000AL FEEDER LENGTH FIRE 4M	70
KTA1000FC4A	KT 4X1000AL EDGEWISE ELBOW	73	KTA1000FT51A	KT 5X1000AL FEEDER LENGTH FIRE	70
KTA1000FC4B	KT 4X1000AL EDGEWISE ELBOW	73	KTA1000FT520	KT 5X1000AL FEEDER LENGTH FIRE 2M	70
KTA1000FC4D	KT 4X1000AL EDGEWISE ELBOW	73	KTA1000FT52B	KT 5X1000AL FEEDER LENGTH FIRE	70
KTA1000FC4E	KT 4X1000AL EDGEWISE ELBOW	73	KTA1000FT52C	KT 5X1000AL FEEDER LENGTH FIRE	70
<b>E</b>			KTA1000FT53D	KT 5X1000AL FEEDER LENGTH FIRE	70
KTA1000FC5A	KT 5X1000AL EDGEWISE ELBOW	73	KTA1000FT53E	KT 5X1000AL FEEDER LENGTH FIRE	70
KTA1000FC5B	KT 5X1000AL EDGEWISE ELBOW	73	KTA1000FT53F	KT 5X1000AL FEEDER LENGTH FIRE	70
KTA1000FC5D	KT 5X1000AL EDGEWISE ELBOW	73	KTA1000FT540	KT 5X1000AL FEEDER LENGTH FIRE 4M	70
KTA1000FC5E	KT 5X1000AL EDGEWISE ELBOW	73	KTA1000FT71A	KT 5X1000AL FEEDER LENGTH FIRE	70
KTA1000FC7A	KT 5X1000AL EDGEWISE ELBOW	73	KTA1000FT720	KT 5X1000AL FEEDER LENGTH FIRE 2M	70
KTA1000FC7B	KT 5X1000AL EDGEWISE ELBOW	73	KTA1000FT72B	KT 5X1000AL FEEDER LENGTH FIRE	70
KTA1000FC7D	KT 5X1000AL EDGEWISE ELBOW	73	KTA1000FT72C	KT 5X1000AL FEEDER LENGTH FIRE	70
KTA1000FC7E	KT 5X1000AL EDGEWISE ELBOW	73	KTA1000FT73D	KT 5X1000AL FEEDER LENGTH FIRE	70
<b>F</b>			KTA1000FT73E	KT 5X1000AL FEEDER LENGTH FIRE	70
KTA1000FJ3	KT 3X1000AL JUNCTION BLOC FIRE RATED	71	KTA1000FT73F	KT 5X1000AL FEEDER LENGTH FIRE	70
KTA1000FJ4	KT 4X1000AL JUNCTION BLOC FIRE RATED	71	KTA1000FT740	KT 5X1000AL FEEDER LENGTH FIRE 4M	70
KTA1000FJ5	KT 5X1000AL JUNCTION BLOC FIRE RATED	71	<b>G</b>		
KTA1000FJ6	KT 4X1000AL JUNCTION BLOC FIRE RATED	71	KTA1000LC3A	KT 3X1000AL EDGEWISE ELBOW	61
KTA1000FJ7	KT 5X1000AL JUNCTION BLOC FIRE RATED	71	KTA1000LC3B	KT 3X1000AL EDGEWISE ELBOW	61
KTA1000FP3A1	KT 3X1000AL FLAT ELBOW N1 FIRE	72	KTA1000LC3D	KT 3X1000AL EDGEWISE ELBOW	61
KTA1000FP3A2	KT 3X1000AL FLAT ELBOW N2 FIRE	72	KTA1000LC3E	KT 3X1000AL EDGEWISE ELBOW	61
KTA1000FP3B1	KT 3X1000AL FLAT ELBOW N1 FIRE	72	KTA1000LC4A	KT 4X1000AL EDGEWISE ELBOW	61
KTA1000FP3B2	KT 3X1000AL FLAT ELBOW N2 FIRE	72	KTA1000LC4B	KT 4X1000AL EDGEWISE ELBOW	61
KTA1000FP3D1	KT 3X1000AL FLAT ELBOW N1 FIRE	72	KTA1000LC4D	KT 4X1000AL EDGEWISE ELBOW	61
KTA1000FP3D2	KT 3X1000AL FLAT ELBOW N2 FIRE	72	KTA1000LC4E	KT 4X1000AL EDGEWISE ELBOW	61
KTA1000FP3E1	KT 3X1000AL FLAT ELBOW N1 FIRE	72	KTA1000LC5A	KT 5X1000AL EDGEWISE ELBOW	61
KTA1000FP3E2	KT 3X1000AL FLAT ELBOW N2 FIRE	72	KTA1000LC5B	KT 5X1000AL EDGEWISE ELBOW	61
KTA1000FP4A1	KT 4X1000AL FLAT ELBOW N1 FIRE	72	KTA1000LC5D	KT 5X1000AL EDGEWISE ELBOW	61
KTA1000FP4A2	KT 4X1000AL FLAT ELBOW N2 FIRE	72	KTA1000LC5E	KT 5X1000AL EDGEWISE ELBOW	61
KTA1000FP4B1	KT 4X1000AL FLAT ELBOW N1 FIRE	72			
KTA1000FP4B2	KT 4X1000AL FLAT ELBOW N2 FIRE	72			
KTA1000FP4D1	KT 4X1000AL FLAT ELBOW N1 FIRE	72			

## Index of catalogue numbers

Cat. no.	Designations	Pages	Cat. no.	Designations	Pages
KTA1000LC7A	KT 5X1000AL EDGEWISE ELBOW	61	KTA1000YA6	KT 4X1000AL JUNCTION BLOC	58
KTA1000LC7B	KT 5X1000AL EDGEWISE ELBOW	61	KTA1000YA7	KT 5X1000AL JUNCTION BLOC	58
KTA1000LC7D	KT 5X1000AL EDGEWISE ELBOW	61	KTA1000ZC31	KT 3X1000AL EDGEWISE ZED N1	66
KTA1000LC7E	KT 5X1000AL EDGEWISE ELBOW	61	KTA1000ZC32	KT 3X1000AL EDGEWISE ZED N2	66
KTA1000LP3A1	KT 3X1000AL FLAT ELBOW N1	60	KTA1000ZC41	KT 4X1000AL EDGEWISE ZED N1	66
KTA1000LP3A2	KT 3X1000AL FLAT ELBOW N2	60	KTA1000ZC42	KT 4X1000AL EDGEWISE ZED N2	66
KTA1000LP3B1	KT 3X1000AL FLAT ELBOW N1	60	KTA1000ZC51	KT 5X1000AL EDGEWISE ZED N1	66
KTA1000LP3B2	KT 3X1000AL FLAT ELBOW N2	60	KTA1000ZC52	KT 5X1000AL EDGEWISE ZED N2	66
KTA1000LP3C1	KT 3X1000AL FLAT ELBOW N1	61	KTA1000ZC71	KT 5X1000AL EDGEWISE ZED N1	66
KTA1000LP3C2	KT 3X1000AL FLAT ELBOW N2	61	KTA1000ZC72	KT 5X1000AL EDGEWISE ZED N2	66
KTA1000LP3D1	KT 3X1000AL FLAT ELBOW N1	60	KTA1000ZP3	KT 3X1000AL ZED ON FLAT	66
KTA1000LP3D2	KT 3X1000AL FLAT ELBOW N2	60	KTA1000ZP4	KT 4X1000AL ZED ON FLAT	66
KTA1000LP3E1	KT 3X1000AL FLAT ELBOW N1	60	KTA1000ZP5	KT 5X1000AL ZED ON FLAT	66
KTA1000LP3E2	KT 3X1000AL FLAT ELBOW N2	60	KTA1000ZP7	KT 5X1000AL ZED ON FLAT	66
KTA1000LP4A1	KT 4X1000AL FLAT ELBOW N1	60			
KTA1000LP4A2	KT 4X1000AL FLAT ELBOW N2	60	<b>KTA1250</b>		
KTA1000LP4B1	KT 4X1000AL FLAT ELBOW N1	60	KTA1250CP31	KT 3X1250AL FLAT EDGEWISE N1	68
KTA1000LP4B2	KT 4X1000AL FLAT ELBOW N2	60	KTA1250CP32	KT 3X1250AL FLAT EDGEWISE N2	68
KTA1000LP4C1	KT 4X1000AL FLAT ELBOW N1	61	KTA1250CP33	KT 3X1250AL FLAT EDGEWISE N3	68
KTA1000LP4C2	KT 4X1000AL FLAT ELBOW N2	61	KTA1250CP34	KT 3X1250AL FLAT EDGEWISE N4	68
KTA1000LP4D1	KT 4X1000AL FLAT ELBOW N1	60	KTA1250CP41	KT 4X1250AL FLAT EDGEWISE N1	68
KTA1000LP4D2	KT 4X1000AL FLAT ELBOW N2	60	KTA1250CP42	KT 4X1250AL FLAT EDGEWISE N2	68
KTA1000LP4E1	KT 4X1000AL FLAT ELBOW N1	60	KTA1250CP43	KT 4X1250AL FLAT EDGEWISE N3	68
KTA1000LP4E2	KT 4X1000AL FLAT ELBOW N2	60	KTA1250CP44	KT 4X1250AL FLAT EDGEWISE N4	68
KTA1000LP5A1	KT 5X1000AL FLAT ELBOW N1	60	KTA1250CP51	KT 5X1250AL FLAT EDGEWISE N1	68
KTA1000LP5A2	KT 5X1000AL FLAT ELBOW N2	60	KTA1250CP52	KT 5X1250AL FLAT EDGEWISE N2	68
KTA1000LP5B1	KT 5X1000AL FLAT ELBOW N1	60	KTA1250CP53	KT 5X1250AL FLAT EDGEWISE N3	68
KTA1000LP5B2	KT 5X1000AL FLAT ELBOW N2	60	KTA1250CP54	KT 5X1250AL FLAT EDGEWISE N4	68
KTA1000LP5C1	KT 5X1000AL FLAT ELBOW N1	61	KTA1250CP71	KT 5X1250AL FLAT EDGEWISE N1	68
KTA1000LP5C2	KT 5X1000AL FLAT ELBOW N2	61	KTA1250CP72	KT 5X1250AL FLAT EDGEWISE N2	68
KTA1000LP5D1	KT 5X1000AL FLAT ELBOW N1	60	KTA1250CP73	KT 5X1250AL FLAT EDGEWISE N3	68
KTA1000LP5D2	KT 5X1000AL FLAT ELBOW N2	60	KTA1250CP74	KT 5X1250AL FLAT EDGEWISE N4	68
KTA1000LP5E1	KT 5X1000AL FLAT ELBOW N1	60	KTA1250DB310	KT 3X1250AL EXPANSION UNIT	56
KTA1000LP5E2	KT 5X1000AL FLAT ELBOW N2	60	KTA1250DB410	KT 4X1250AL EXPANSION UNIT	56
KTA1000LP7A1	KT 5X1000AL FLAT ELBOW N1	60	KTA1250DB510	KT 5X1250AL EXPANSION UNIT	56
KTA1000LP7A2	KT 5X1000AL FLAT ELBOW N2	60	KTA1250DB710	KT 5X1250AL EXPANSION UNIT	56
KTA1000LP7B1	KT 5X1000AL FLAT ELBOW N1	60	KTA1250EB320	KT 3X1250AL BOLT ON LENGTH 2M	52
KTA1000LP7B2	KT 5X1000AL FLAT ELBOW N2	60	KTA1250EB340	KT 3X1250AL BOLT ON LENGTH 4M	52
KTA1000LP7C1	KT 5X1000AL FLAT ELBOW N1	61	KTA1250EB420	KT 4X1250AL BOLT ON LENGTH 2M	52
KTA1000LP7C2	KT 5X1000AL FLAT ELBOW N2	61	KTA1250EB440	KT 4X1250AL BOLT ON LENGTH 4M	52
KTA1000LP7D1	KT 5X800AL FLAT ELBOW N1	60	KTA1250EB520	KT 5X1250AL BOLT ON LENGTH 2M	52
KTA1000LP7D2	KT 5X800AL FLAT ELBOW N2	60	KTA1250EB540	KT 5X1250AL BOLT ON LENGTH 4M	52
KTA1000LP7E1	KT 5X800AL FLAT ELBOW N1	60	KTA1250EB720	KT 5X1250AL BOLT ON LENGTH 2M	52
KTA1000LP7E2	KT 5X800AL FLAT ELBOW N2	60	KTA1250EB740	KT 5X1250AL BOLT ON LENGTH 4M	52
KTA1000PL31	KT 3X1000AL LINE PROTECTOR NS	128	KTA1250ED3201	KT 1X1250AL PLUG-IN LENGTH 2M	50
KTA1000PL41	KT 4X1000AL LINE PROTECTOR NS	128	KTA1250ED3203	KT 3X1250AL PLUG-IN LENGTH 2M	50
KTA1000PL51	KT 5X1000AL LINE PROTECTOR NS	128	KTA1250ED3301	KT 1X1250AL PLUG-IN LENGTH	50
KTA1000PL71	KT 5X1000AL LINE PROTECTOR NS	128	KTA1250ED3302	KT 2X1250AL PLUG-IN LENGTH	50
KTA1000SL31	KT 3X1000AL ISOLATOR UNIT NA	125	KTA1250ED3351	KT 1X1250AL PLUG-IN LENGTH	50
KTA1000SL41	KT 4X1000AL ISOLATOR UNIT NA	125	KTA1250ED3353	KT 3X1250AL PLUG-IN LENGTH	50
KTA1000SL51	KT 5X1000AL ISOLATOR UNIT NA	125	KTA1250ED3403	KT 3X1250AL PLUG-IN LENGTH 4M	50
KTA1000SL71	KT 5X1000AL ISOLATOR UNIT NA	125	KTA1250ED4201	KT 1X1250AL PLUG-IN LENGTH 2M	50
KTA1000TC3	KT 3X1000AL TEE ON EDGE	65	KTA1250ED4203	KT 4X1250AL PLUG-IN LENGTH 2M	50
KTA1000TC4	KT 4X1000AL TEE ON EDGE	65	KTA1250ED4301	KT 1X1250AL PLUG-IN LENGTH	50
KTA1000TC5	KT 5X1000AL TEE ON EDGE	65	KTA1250ED4302	KT 2X1250AL PLUG-IN LENGTH	50
KTA1000TC7	KT 5X1000AL TEE ON EDGE	65	KTA1250ED4351	KT 1X1250AL PLUG-IN LENGTH	50
KTA1000TN410	KT 4X1000AL NEUTRAL PERMUTA	56	KTA1250ED4353	KT 3X1250AL PLUG-IN LENGTH	50
KTA1000TN610	KT 4X1000AL NEUTRAL PERMUTA	56	KTA1250ED4403	KT 4X1250AL PLUG-IN LENGTH 4M	50
KTA1000TP410	KT 4X1000AL PHASES PERMUTA	56	KTA1250ED5201	KT 1X1250AL PLUG-IN LENGTH 2M	50
KTA1000TP610	KT 4X1000AL PHASES PERMUTA	56	KTA1250ED5203	KT 5X1250AL PLUG-IN LENGTH 2M	50
KTA1000YA3	KT 3X1000AL JUNCTION BLOC	58	KTA1250ED5301	KT 1X1250AL PLUG-IN LENGTH	50
KTA1000YA4	KT 4X1000AL JUNCTION BLOC	58	KTA1250ED5302	KT 2X1250AL PLUG-IN LENGTH	50
KTA1000YA5	KT 5X1000AL JUNCTION BLOC	58	KTA1250ED5351	KT 1X1250AL PLUG-IN LENGTH	50

## Index of catalogue numbers

Cat. no.	Designations	Pages
<b>KTA1250ED5353</b>	KT 3X1250AL PLUG-IN LENGTH	50
<b>KTA1250ED5403</b>	KT 5X1250AL PLUG-IN LENGTH 4M	50
<b>KTA1250ED7201</b>	KT 1X1250AL PLUG-IN LENGTH 2M	50
<b>KTA1250ED7203</b>	KT 5X1250AL PLUG-IN LENGTH 2M	50
<b>KTA1250ED7301</b>	KT 1X1250AL PLUG-IN LENGTH	50
<b>KTA1250ED7302</b>	KT 2X1250AL PLUG-IN LENGTH	50
<b>KTA1250ED7351</b>	KT 1X1250AL PLUG-IN LENGTH	50
<b>KTA1250ED7353</b>	KT 3X1250AL PLUG-IN LENGTH	50
<b>KTA1250ED7403</b>	KT 5X1250AL PLUG-IN LENGTH 4M	50
<b>KTA1250EH320</b>	KT 3X1250AL KH PLUG-IN LENGTH 2M	53
<b>KTA1250EH340</b>	KT 3X1250AL KH PLUG-IN LENGTH 4M	53
<b>KTA1250EH420</b>	KT 4X1250AL KH PLUG-IN LENGTH 2M	53
<b>KTA1250EH440</b>	KT 4X1250AL KH PLUG-IN LENGTH 4M	53
<b>KTA1250EH520</b>	KT 5X1250AL KH PLUG-IN LENGTH 2M	53
<b>KTA1250EH540</b>	KT 5X1250AL KH PLUG-IN LENGTH 4M	53
<b>KTA1250EL31</b>	KT 3X1250AL FEED UNIT EL N1	92
<b>KTA1250EL32</b>	KT 3X1250AL FEED UNIT EL N2	92
<b>KTA1250EL33</b>	KT 3X1250AL FEED UNIT EL N3	94
<b>KTA1250EL34</b>	KT 3X1250AL FEED UNIT EL N4	94
<b>KTA1250EL35</b>	KT 3X1250AL FEED UNIT EL N5	95
<b>KTA1250EL41</b>	KT 4X1250AL FEED UNIT EL N1	92
<b>KTA1250EL42</b>	KT 4X1250AL FEED UNIT EL N2	92
<b>KTA1250EL43</b>	KT 4X1250AL FEED UNIT EL N3	94
<b>KTA1250EL44</b>	KT 4X1250AL FEED UNIT EL N4	94
<b>KTA1250EL45</b>	KT 4X1250AL FEED UNIT EL N5	95
<b>KTA1250EL51</b>	KT 5X1250AL FEED UNIT EL N1	92
<b>KTA1250EL52</b>	KT 5X1250AL FEED UNIT EL N2	92
<b>KTA1250EL53</b>	KT 5X1250AL FEED UNIT EL N3	94
<b>KTA1250EL54</b>	KT 5X1250AL FEED UNIT EL N4	94
<b>KTA1250EL55</b>	KT 5X1250AL FEED UNIT EL N5	95
<b>KTA1250EL71</b>	KT 5X1250AL FEED UNIT EL N1	92
<b>KTA1250EL72</b>	KT 5X1250AL FEED UNIT EL N2	92
<b>KTA1250EL73</b>	KT 5X1250AL FEED UNIT EL N3	94
<b>KTA1250EL74</b>	KT 5X1250AL FEED UNIT EL N4	94
<b>KTA1250EL75</b>	KT 5X1250AL FEED UNIT EL N5	95
<b>KTA1250ER31</b>	KT 3X1250AL FEED UNIT ER N1	79
<b>KTA1250ER32</b>	KT 3X1250AL FEED UNIT ER N2	79
<b>KTA1250ER33</b>	KT 3X1250AL FEED UNIT ER N3	80
<b>KTA1250ER34</b>	KT 3X1250AL FEED UNIT ER N4	80
<b>KTA1250ER35</b>	KT 3X1250AL FEED UNIT ER N5	81
<b>KTA1250ER36</b>	KT 3X1250AL FEED UNIT ER N6	81
<b>KTA1250ER37</b>	KT 3X1250AL FEED UNIT ER N7	85
<b>KTA1250ER41</b>	KT 4X1250AL FEED UNIT ER N1	79
<b>KTA1250ER42</b>	KT 4X1250AL FEED UNIT ER N2	79
<b>KTA1250ER43</b>	KT 4X1250AL FEED UNIT ER N3	80
<b>KTA1250ER44</b>	KT 4X1250AL FEED UNIT ER N4	80
<b>KTA1250ER45</b>	KT 4X1250AL FEED UNIT ER N5	81
<b>KTA1250ER46</b>	KT 4X1250AL FEED UNIT ER N6	81
<b>KTA1250ER47</b>	KT 4X1250AL FEED UNIT ER N7	85
<b>KTA1250ER51</b>	KT 5X1250AL FEED UNIT ER N1	79
<b>KTA1250ER52</b>	KT 5X1250AL FEED UNIT ER N2	79
<b>KTA1250ER53</b>	KT 5X1250AL FEED UNIT ER N3	80
<b>KTA1250ER54</b>	KT 5X1250AL FEED UNIT ER N4	80
<b>KTA1250ER55</b>	KT 5X1250AL FEED UNIT ER N5	81
<b>KTA1250ER56</b>	KT 5X1250AL FEED UNIT ER N6	81
<b>KTA1250ER57</b>	KT 5X1250AL FEED UNIT ER N7	85
<b>KTA1250ER71</b>	KT 5X1250AL FEED UNIT ER N1	79
<b>KTA1250ER72</b>	KT 5X1250AL FEED UNIT ER N2	79
<b>KTA1250ER73</b>	KT 5X1250AL FEED UNIT ER N3	80
<b>KTA1250ER74</b>	KT 5X1250AL FEED UNIT ER N4	80
<b>KTA1250ER75</b>	KT 5X1250AL FEED UNIT ER N5	81
<b>KTA1250ER76</b>	KT 5X1250AL FEED UNIT ER N6	81
<b>KTA1250ER77</b>	KT 5X1250AL FEED UNIT ER N7	85

Cat. no.	Designations	Pages
<b>KTA1250ET31A</b>	KT 3X1250AL FEEDER LENGTH	50
<b>KTA1250ET320</b>	KT 3X1250AL FEEDER LENGTH 2M	50
<b>KTA1250ET32B</b>	KT 3X1250AL FEEDER LENGTH	50
<b>KTA1250ET32C</b>	KT 3X1250AL FEEDER LENGTH	50
<b>KTA1250ET33D</b>	KT 3X1250AL FEEDER LENGTH	50
<b>KTA1250ET33E</b>	KT 3X1250AL FEEDER LENGTH	50
<b>KTA1250ET33F</b>	KT 3X1250AL FEEDER LENGTH	50
<b>KTA1250ET340</b>	KT 3X1250AL FEEDER LENGTH 4M	50
<b>KTA1250ET41A</b>	KT 4X1250AL FEEDER LENGTH	50
<b>KTA1250ET420</b>	KT 4X1250AL FEEDER LENGTH 2M	50
<b>KTA1250ET42B</b>	KT 4X1250AL FEEDER LENGTH	50
<b>KTA1250ET42C</b>	KT 4X1250AL FEEDER LENGTH	50
<b>KTA1250ET43D</b>	KT 4X1250AL FEEDER LENGTH	50
<b>KTA1250ET43E</b>	KT 4X1250AL FEEDER LENGTH	50
<b>KTA1250ET43F</b>	KT 4X1250AL FEEDER LENGTH	50
<b>KTA1250ET440</b>	KT 4X1250AL FEEDER LENGTH 4M	50
<b>KTA1250ET51A</b>	KT 5X1250AL FEEDER LENGTH	50
<b>KTA1250ET520</b>	KT 5X1250AL FEEDER LENGTH 2M	50
<b>KTA1250ET52B</b>	KT 5X1250AL FEEDER LENGTH	50
<b>KTA1250ET52C</b>	KT 5X1250AL FEEDER LENGTH	50
<b>KTA1250ET53D</b>	KT 5X1250AL FEEDER LENGTH	50
<b>KTA1250ET53E</b>	KT 5X1250AL FEEDER LENGTH	50
<b>KTA1250ET53F</b>	KT 5X1250AL FEEDER LENGTH	50
<b>KTA1250ET540</b>	KT 5X1250AL FEEDER LENGTH 4M	50
<b>KTA1250ET71A</b>	KT 5X1250AL FEEDER LENGTH	50
<b>KTA1250ET720</b>	KT 5X1250AL FEEDER LENGTH 2M	50
<b>KTA1250ET72B</b>	KT 5X1250AL FEEDER LENGTH	50
<b>KTA1250ET72C</b>	KT 5X1250AL FEEDER LENGTH	50
<b>KTA1250ET73D</b>	KT 5X1250AL FEEDER LENGTH	50
<b>KTA1250ET73E</b>	KT 5X1250AL FEEDER LENGTH	50
<b>KTA1250ET73F</b>	KT 5X1250AL FEEDER LENGTH	50
<b>KTA1250ET740</b>	KT 5X1250AL FEEDER LENGTH 4M	50
<b>KTA1250FC3A</b>	KT 3X1250AL EDGEWISE ELBOW	73
<b>KTA1250FC3B</b>	KT 3X1250AL EDGEWISE ELBOW	73
<b>KTA1250FC3D</b>	KT 3X1250AL EDGEWISE ELBOW	73
<b>KTA1250FC3E</b>	KT 3X1250AL EDGEWISE ELBOW	73
<b>KTA1250FC4A</b>	KT 4X1250AL EDGEWISE ELBOW	73
<b>KTA1250FC4B</b>	KT 4X1250AL EDGEWISE ELBOW	73
<b>KTA1250FC4D</b>	KT 4X1250AL EDGEWISE ELBOW	73
<b>KTA1250FC4E</b>	KT 4X1250AL EDGEWISE ELBOW	73
<b>KTA1250FC5A</b>	KT 5X1250AL EDGEWISE ELBOW	73
<b>KTA1250FC5B</b>	KT 5X1250AL EDGEWISE ELBOW	73
<b>KTA1250FC5D</b>	KT 5X1250AL EDGEWISE ELBOW	73
<b>KTA1250FC5E</b>	KT 5X1250AL EDGEWISE ELBOW	73
<b>KTA1250FC7A</b>	KT 5X1250AL EDGEWISE ELBOW	73
<b>KTA1250FC7B</b>	KT 5X1250AL EDGEWISE ELBOW	73
<b>KTA1250FC7D</b>	KT 5X1250AL EDGEWISE ELBOW	73
<b>KTA1250FC7E</b>	KT 5X1250AL EDGEWISE ELBOW	73
<b>KTA1250FJ3</b>	KT 3X1250AL JUNCTION BLOC FIRE RATED	71
<b>KTA1250FJ4</b>	KT 4X1250AL JUNCTION BLOC FIRE RATED	71
<b>KTA1250FJ5</b>	KT 5X1250AL JUNCTION BLOC FIRE RATED	71
<b>KTA1250FJ6</b>	KT 4X1250AL JUNCTION BLOC FIRE RATED	71
<b>KTA1250FJ7</b>	KT 5X1250AL JUNCTION BLOC FIRE RATED	71
<b>KTA1250FP3A1</b>	KT 3X1250AL FLAT ELBOW N1 FIRE	72
<b>KTA1250FP3A2</b>	KT 3X1250AL FLAT ELBOW N2 FIRE	72
<b>KTA1250FP3B1</b>	KT 3X1250AL FLAT ELBOW N1 FIRE	72
<b>KTA1250FP3B2</b>	KT 3X1250AL FLAT ELBOW N2 FIRE	72
<b>KTA1250FP3D1</b>	KT 3X1250AL FLAT ELBOW N1 FIRE	72
<b>KTA1250FP3D2</b>	KT 3X1250AL FLAT ELBOW N2 FIRE	72
<b>KTA1250FP3E1</b>	KT 3X1250AL FLAT ELBOW N1 FIRE	72
<b>KTA1250FP3E2</b>	KT 3X1250AL FLAT ELBOW N2 FIRE	72
<b>KTA1250FP4A1</b>	KT 4X1250AL FLAT ELBOW N1 FIRE	72
<b>KTA1250FP4A2</b>	KT 4X1250AL FLAT ELBOW N2 FIRE	72

## Index of catalogue numbers

Cat. no.	Designations	Pages	Cat. no.	Designations	Pages
KTA1250FP4B1	KT 4X1250AL FLAT ELBOW N1 FIRE	72	KTA1250LC5B	KT 5X1250AL EDGEWISE ELBOW	61
KTA1250FP4B2	KT 4X1250AL FLAT ELBOW N2 FIRE	72	KTA1250LC5D	KT 5X1250AL EDGEWISE ELBOW	61
KTA1250FP4D1	KT 4X1250AL FLAT ELBOW N1 FIRE	72	KTA1250LC5E	KT 5X1250AL EDGEWISE ELBOW	61
KTA1250FP4D2	KT 4X1250AL FLAT ELBOW N2 FIRE	72	KTA1250LC7A	KT 5X1250AL EDGEWISE ELBOW	61
KTA1250FP4E1	KT 4X1250AL FLAT ELBOW N1 FIRE	72	KTA1250LC7B	KT 5X1250AL EDGEWISE ELBOW	61
KTA1250FP4E2	KT 4X1250AL FLAT ELBOW N2 FIRE	72	KTA1250LC7D	KT 5X1250AL EDGEWISE ELBOW	61
KTA1250FP5A1	KT 5X1250AL FLAT ELBOW N1 FIRE	72	KTA1250LC7E	KT 5X1250AL EDGEWISE ELBOW	61
KTA1250FP5A2	KT 5X1250AL FLAT ELBOW N2 FIRE	72	KTA1250LP3A1	KT 3X1250AL FLAT ELBOW N1	60
KTA1250FP5B1	KT 5X1250AL FLAT ELBOW N1 FIRE	72	KTA1250LP3A2	KT 3X1250AL FLAT ELBOW N2	60
KTA1250FP5B2	KT 5X1250AL FLAT ELBOW N2 FIRE	72	KTA1250LP3B1	KT 3X1250AL FLAT ELBOW N1	60
KTA1250FP5D1	KT 5X1250AL FLAT ELBOW N1 FIRE	72	KTA1250LP3B2	KT 3X1250AL FLAT ELBOW N2	60
KTA1250FP5D2	KT 5X1250AL FLAT ELBOW N2 FIRE	72	KTA1250LP3C1	KT 3X1250AL FLAT ELBOW N1	61
KTA1250FP5E1	KT 5X1250AL FLAT ELBOW N1 FIRE	72	KTA1250LP3C2	KT 3X1250AL FLAT ELBOW N2	61
KTA1250FP5E2	KT 5X1250AL FLAT ELBOW N2 FIRE	72	KTA1250LP3D1	KT 3X1250AL FLAT ELBOW N1	60
KTA1250FP7A1	KT 5X1250AL FLAT ELBOW N1 FIRE	72	KTA1250LP3D2	KT 3X1250AL FLAT ELBOW N2	60
KTA1250FP7A2	KT 5X1250AL FLAT ELBOW N2 FIRE	72	KTA1250LP3E1	KT 3X1250AL FLAT ELBOW N1	60
KTA1250FP7B1	KT 5X1250AL FLAT ELBOW N1 FIRE	72	KTA1250LP3E2	KT 3X1250AL FLAT ELBOW N2	60
KTA1250FP7B2	KT 5X1250AL FLAT ELBOW N2 FIRE	72	KTA1250LP4A1	KT 4X1250AL FLAT ELBOW N1	60
KTA1250FP7D1	KT 5X1250AL FLAT ELBOW N1 FIRE	72	KTA1250LP4A2	KT 4X1250AL FLAT ELBOW N2	60
KTA1250FP7D2	KT 5X1250AL FLAT ELBOW N2 FIRE	72	KTA1250LP4B1	KT 4X1250AL FLAT ELBOW N1	60
KTA1250FP7E1	KT 5X1250AL FLAT ELBOW N1 FIRE	72	KTA1250LP4B2	KT 4X1250AL FLAT ELBOW N2	60
KTA1250FP7E2	KT 5X1250AL FLAT ELBOW N2 FIRE	72	KTA1250LP4C1	KT 4X1250AL FLAT ELBOW N1	61
KTA1250FT31A	KT 3X1250AL FEEDER LENGTH FIRE	70	KTA1250LP4C2	KT 4X1250AL FLAT ELBOW N2	61
KTA1250FT320	KT 3X1250AL FEEDER LENGTH FIRE 2M	70	KTA1250LP4D1	KT 4X1250AL FLAT ELBOW N1	60
KTA1250FT32B	KT 3X1250AL FEEDER LENGTH FIRE	70	KTA1250LP4D2	KT 4X1250AL FLAT ELBOW N2	60
KTA1250FT32C	KT 3X1250AL FEEDER LENGTH FIRE	70	KTA1250LP4E1	KT 4X1250AL FLAT ELBOW N1	60
KTA1250FT33D	KT 3X1250AL FEEDER LENGTH FIRE	70	KTA1250LP4E2	KT 4X1250AL FLAT ELBOW N2	60
KTA1250FT33E	KT 3X1250AL FEEDER LENGTH FIRE	70	KTA1250LP5A1	KT 5X1250AL FLAT ELBOW N1	60
KTA1250FT33F	KT 3X1250AL FEEDER LENGTH FIRE	70	KTA1250LP5A2	KT 5X1250AL FLAT ELBOW N2	60
KTA1250FT340	KT 3X1250AL FEEDER LENGTH FIRE 4M	70	KTA1250LP5B1	KT 5X1250AL FLAT ELBOW N1	60
KTA1250FT41A	KT 4X1250AL FEEDER LENGTH FIRE	70	KTA1250LP5B2	KT 5X1250AL FLAT ELBOW N2	60
KTA1250FT420	KT 4X1250AL FEEDER LENGTH FIRE 2M	70	KTA1250LP5C1	KT 5X1250AL FLAT ELBOW N1	61
KTA1250FT42B	KT 4X1250AL FEEDER LENGTH FIRE	70	KTA1250LP5C2	KT 5X1250AL FLAT ELBOW N2	61
KTA1250FT42C	KT 4X1250AL FEEDER LENGTH FIRE	70	KTA1250LP5D1	KT 5X1250AL FLAT ELBOW N1	60
KTA1250FT43D	KT 4X1250AL FEEDER LENGTH FIRE	70	KTA1250LP5D2	KT 5X1250AL FLAT ELBOW N2	60
KTA1250FT43E	KT 4X1250AL FEEDER LENGTH FIRE	70	KTA1250LP5E1	KT 5X1250AL FLAT ELBOW N1	60
KTA1250FT43F	KT 4X1250AL FEEDER LENGTH FIRE	70	KTA1250LP5E2	KT 5X1250AL FLAT ELBOW N2	60
KTA1250FT440	KT 4X1250AL FEEDER LENGTH FIRE 4M	70	KTA1250LP7A1	KT 5X1250AL FLAT ELBOW N1	60
KTA1250FT51A	KT 5X1250AL FEEDER LENGTH FIRE	70	KTA1250LP7A2	KT 5X1250AL FLAT ELBOW N2	60
KTA1250FT520	KT 5X1250AL FEEDER LENGTH FIRE 2M	70	KTA1250LP7B1	KT 5X1250AL FLAT ELBOW N1	60
KTA1250FT52B	KT 5X1250AL FEEDER LENGTH FIRE	70	KTA1250LP7B2	KT 5X1250AL FLAT ELBOW N2	60
KTA1250FT52C	KT 5X1250AL FEEDER LENGTH FIRE	70	KTA1250LP7C1	KT 5X1250AL FLAT ELBOW N1	61
KTA1250FT53D	KT 5X1250AL FEEDER LENGTH FIRE	70	KTA1250LP7C2	KT 5X1250AL FLAT ELBOW N2	61
KTA1250FT53E	KT 5X1250AL FEEDER LENGTH FIRE	70	KTA1250LP7D1	KT 5X1250AL FLAT ELBOW N1	60
KTA1250FT53F	KT 5X1250AL FEEDER LENGTH FIRE	70	KTA1250LP7D2	KT 5X1250AL FLAT ELBOW N2	60
KTA1250FT540	KT 5X1250AL FEEDER LENGTH FIRE 4M	70	KTA1250LP7E1	KT 5X1250AL FLAT ELBOW N1	60
KTA1250FT71A	KT 5X1250AL FEEDER LENGTH FIRE	70	KTA1250LP7E2	KT 5X1250AL FLAT ELBOW N2	60
KTA1250FT720	KT 5X1250AL FEEDER LENGTH FIRE 2M	70	KTA1250PL31	KT 3X1250AL LINE PROTECTOR NS	128
KTA1250FT72B	KT 5X1250AL FEEDER LENGTH FIRE	70	KTA1250PL41	KT 4X1250AL LINE PROTECTOR NS	128
KTA1250FT72C	KT 5X1250AL FEEDER LENGTH FIRE	70	KTA1250PL51	KT 5X1250AL LINE PROTECTOR NS	128
KTA1250FT73D	KT 5X1250AL FEEDER LENGTH FIRE	70	KTA1250PL71	KT 5X1250AL LINE PROTECTOR NS	128
KTA1250FT73E	KT 5X1250AL FEEDER LENGTH FIRE	70	KTA1250SL31	KT 3X1250AL ISOLATOR UNIT NA	125
KTA1250FT73F	KT 5X1250AL FEEDER LENGTH FIRE	70	KTA1250SL41	KT 4X1250AL ISOLATOR UNIT NA	125
KTA1250FT740	KT 5X1250AL FEEDER LENGTH FIRE 4M	70	KTA1250SL51	KT 5X1250AL ISOLATOR UNIT NA	125
KTA1250LC3A	KT 3X1250AL EDGEWISE ELBOW	61	KTA1250SL71	KT 5X1250AL ISOLATOR UNIT NA	125
KTA1250LC3B	KT 3X1250AL EDGEWISE ELBOW	61	KTA1250TC3	KT 3X1250AL TEE ON EDGE	65
KTA1250LC3D	KT 3X1250AL EDGEWISE ELBOW	61	KTA1250TC4	KT 4X1250AL TEE ON EDGE	65
KTA1250LC3E	KT 3X1250AL EDGEWISE ELBOW	61	KTA1250TC5	KT 5X1250AL TEE ON EDGE	65
KTA1250LC4A	KT 4X1250AL EDGEWISE ELBOW	61	KTA1250TC7	KT 5X1250AL TEE ON EDGE	65
KTA1250LC4B	KT 4X1250AL EDGEWISE ELBOW	61	KTA1250TN410	KT 4X1250AL NEUTRAL PERMUTA	56
KTA1250LC4D	KT 4X1250AL EDGEWISE ELBOW	61	KTA1250TN610	KT 4X1250AL NEUTRAL PERMUTA	56
KTA1250LC4E	KT 4X1250AL EDGEWISE ELBOW	61	KTA1250TP410	KT 4X1250AL PHASES PERMUTA	56
KTA1250LC5A	KT 5X1250AL EDGEWISE ELBOW	61	KTA1250TP610	KT 4X1250AL PHASES PERMUTA	56

A

B

C

D

E

F

G

## Index of catalogue numbers

Cat. no.	Designations	Pages	Cat. no.	Designations	Pages
<b>KTA1250YA3</b>	KT 3X1250AL JUNCTION BLOC	58	<b>KTA1600ED5301</b>	KT 1X1600AL PLUG-IN LENGTH	50
<b>KTA1250YA4</b>	KT 4X1250AL JUNCTION BLOC	58	<b>KTA1600ED5302</b>	KT 2X1600AL PLUG-IN LENGTH	50
<b>KTA1250YA5</b>	KT 5X1250AL JUNCTION BLOC	58	<b>KTA1600ED5351</b>	KT 1X1600AL PLUG-IN LENGTH	50
<b>KTA1250YA6</b>	KT 4X1250AL JUNCTION BLOC	58	<b>KTA1600ED5353</b>	KT 3X1600AL PLUG-IN LENGTH	50
<b>KTA1250YA7</b>	KT 5X1250AL JUNCTION BLOC	58	<b>KTA1600ED5403</b>	KT 5X1600AL PLUG-IN LENGTH 4M	50
<b>KTA1250ZC31</b>	KT 3X1250AL EDGEWISE ZED N1	66	<b>KTA1600ED7201</b>	KT 1X1600AL PLUG-IN LENGTH 2M	50
<b>KTA1250ZC32</b>	KT 3X1250AL EDGEWISE ZED N2	66	<b>KTA1600ED7203</b>	KT 5X1600AL PLUG-IN LENGTH 2M	50
<b>KTA1250ZC41</b>	KT 4X1250AL EDGEWISE ZED N1	66	<b>KTA1600ED7301</b>	KT 1X1600AL PLUG-IN LENGTH	50
<b>KTA1250ZC42</b>	KT 4X1250AL EDGEWISE ZED N2	66	<b>KTA1600ED7302</b>	KT 2X1600AL PLUG-IN LENGTH	50
<b>KTA1250ZC51</b>	KT 5X1250AL EDGEWISE ZED N1	66	<b>KTA1600ED7351</b>	KT 1X1600AL PLUG-IN LENGTH	50
<b>KTA1250ZC52</b>	KT 5X1250AL EDGEWISE ZED N2	66	<b>KTA1600ED7353</b>	KT 3X1600AL PLUG-IN LENGTH	50
<b>KTA1250ZC71</b>	KT 5X1250AL EDGEWISE ZED N1	66	<b>KTA1600ED7403</b>	KT 5X1600AL PLUG-IN LENGTH 4M	50
<b>KTA1250ZC72</b>	KT 5X1250AL EDGEWISE ZED N2	66	<b>KTA1600EH320</b>	KT 3X1600AL KH PLUG-IN LENGTH 2M	53
<b>KTA1250ZP3</b>	KT 3X1250AL ZED ON FLAT	66	<b>KTA1600EH340</b>	KT 3X1600AL KH PLUG-IN LENGTH 4M	53
<b>KTA1250ZP4</b>	KT 4X1250AL ZED ON FLAT	66	<b>KTA1600EH420</b>	KT 4X1600AL KH PLUG-IN LENGTH 2M	53
<b>KTA1250ZP5</b>	KT 5X1250AL ZED ON FLAT	66	<b>KTA1600EH440</b>	KT 4X1600AL KH PLUG-IN LENGTH 4M	53
<b>KTA1250ZP7</b>	KT 5X1250AL ZED ON FLAT	66	<b>KTA1600EH520</b>	KT 5X1600AL KH PLUG-IN LENGTH 2M	53
			<b>KTA1600EH540</b>	KT 5X1600AL KH PLUG-IN LENGTH 4M	53
			<b>KTA1600EL31</b>	KT 3X1600AL FEED UNIT EL N1	92
<b>KTA1600</b>			<b>KTA1600EL32</b>	KT 3X1600AL FEED UNIT EL N2	92
<b>KTA1600CP31</b>	KT 3X1600AL FLAT EDGEWISE N1	68	<b>KTA1600EL33</b>	KT 3X1600AL FEED UNIT EL N3	94
<b>KTA1600CP32</b>	KT 3X1600AL FLAT EDGEWISE N2	68	<b>KTA1600EL34</b>	KT 3X1600AL FEED UNIT EL N4	94
<b>KTA1600CP33</b>	KT 3X1600AL FLAT EDGEWISE N3	68	<b>KTA1600EL35</b>	KT 3X1600AL FEED UNIT EL N5	95
<b>KTA1600CP34</b>	KT 3X1600AL FLAT EDGEWISE N4	68	<b>KTA1600EL41</b>	KT 4X1600AL FEED UNIT EL N1	92
<b>KTA1600CP41</b>	KT 4X1600AL FLAT EDGEWISE N1	68	<b>KTA1600EL42</b>	KT 4X1600AL FEED UNIT EL N2	92
<b>KTA1600CP42</b>	KT 4X1600AL FLAT EDGEWISE N2	68	<b>KTA1600EL43</b>	KT 4X1600AL FEED UNIT EL N3	94
<b>KTA1600CP43</b>	KT 4X1600AL FLAT EDGEWISE N3	68	<b>KTA1600EL44</b>	KT 4X1600AL FEED UNIT EL N4	94
<b>KTA1600CP44</b>	KT 4X1600AL FLAT EDGEWISE N4	68	<b>KTA1600EL45</b>	KT 4X1600AL FEED UNIT EL N5	95
<b>KTA1600CP51</b>	KT 5X1600AL FLAT EDGEWISE N1	68	<b>KTA1600EL51</b>	KT 5X1600AL FEED UNIT EL N1	92
<b>KTA1600CP52</b>	KT 5X1600AL FLAT EDGEWISE N2	68	<b>KTA1600EL52</b>	KT 5X1600AL FEED UNIT EL N2	92
<b>KTA1600CP53</b>	KT 5X1600AL FLAT EDGEWISE N3	68	<b>KTA1600EL53</b>	KT 5X1600AL FEED UNIT EL N3	94
<b>KTA1600CP54</b>	KT 5X1600AL FLAT EDGEWISE N4	68	<b>KTA1600EL54</b>	KT 5X1600AL FEED UNIT EL N4	94
<b>KTA1600CP71</b>	KT 5X1600AL FLAT EDGEWISE N1	68	<b>KTA1600EL55</b>	KT 5X1600AL FEED UNIT EL N5	95
<b>KTA1600CP72</b>	KT 5X1600AL FLAT EDGEWISE N2	68	<b>KTA1600EL71</b>	KT 5X1600AL FEED UNIT EL N1	92
<b>KTA1600CP73</b>	KT 5X1600AL FLAT EDGEWISE N3	68	<b>KTA1600EL72</b>	KT 5X1600AL FEED UNIT EL N2	92
<b>KTA1600CP74</b>	KT 5X1600AL FLAT EDGEWISE N4	68	<b>KTA1600EL73</b>	KT 5X1600AL FEED UNIT EL N3	94
<b>KTA1600DB310</b>	KT 3X1600AL EXPANSION UNIT	56	<b>KTA1600EL74</b>	KT 5X1600AL FEED UNIT EL N4	94
<b>KTA1600DB410</b>	KT 4X1600AL EXPANSION UNIT	56	<b>KTA1600EL75</b>	KT 5X1600AL FEED UNIT EL N5	95
<b>KTA1600DB510</b>	KT 5X1600AL EXPANSION UNIT	56	<b>KTA1600ER31</b>	KT 3X1600AL FEED UNIT ER N1	79
<b>KTA1600DB710</b>	KT 5X1600AL EXPANSION UNIT	56	<b>KTA1600ER32</b>	KT 3X1600AL FEED UNIT ER N2	79
<b>KTA1600EB320</b>	KT 3X1600AL BOLT ON LENGTH 2M	52	<b>KTA1600ER33</b>	KT 3X1600AL FEED UNIT ER N3	80
<b>KTA1600EB340</b>	KT 3X1600AL BOLT ON LENGTH 4M	52	<b>KTA1600ER34</b>	KT 3X1600AL FEED UNIT ER N4	80
<b>KTA1600EB420</b>	KT 4X1600AL BOLT ON LENGTH 2M	52	<b>KTA1600ER35</b>	KT 3X1600AL FEED UNIT ER N5	81
<b>KTA1600EB440</b>	KT 4X1600AL BOLT ON LENGTH 4M	52	<b>KTA1600ER36</b>	KT 3X1600AL FEED UNIT ER N6	81
<b>KTA1600EB520</b>	KT 5X1600AL BOLT ON LENGTH 2M	52	<b>KTA1600ER37</b>	KT 3X1600AL FEED UNIT ER N7	85
<b>KTA1600EB540</b>	KT 5X1600AL BOLT ON LENGTH 4M	52	<b>KTA1600ER41</b>	KT 4X1600AL FEED UNIT ER N1	79
<b>KTA1600EB720</b>	KT 5X1600AL BOLT ON LENGTH 2M	52	<b>KTA1600ER42</b>	KT 4X1600AL FEED UNIT ER N2	79
<b>KTA1600EB740</b>	KT 5X1600AL BOLT ON LENGTH 4M	52	<b>KTA1600ER43</b>	KT 4X1600AL FEED UNIT ER N3	80
<b>KTA1600ED3201</b>	KT 1X1600AL PLUG-IN LENGTH 2M	50	<b>KTA1600ER44</b>	KT 4X1600AL FEED UNIT ER N4	80
<b>KTA1600ED3203</b>	KT 3X1600AL PLUG-IN LENGTH 2M	50	<b>KTA1600ER45</b>	KT 4X1600AL FEED UNIT ER N5	81
<b>KTA1600ED3301</b>	KT 1X1600AL PLUG-IN LENGTH	50	<b>KTA1600ER46</b>	KT 4X1600AL FEED UNIT ER N6	81
<b>KTA1600ED3302</b>	KT 2X1600AL PLUG-IN LENGTH	50	<b>KTA1600ER47</b>	KT 4X1600AL FEED UNIT ER N7	85
<b>KTA1600ED3351</b>	KT 1X1600AL PLUG-IN LENGTH	50	<b>KTA1600ER51</b>	KT 5X1600AL FEED UNIT ER N1	79
<b>KTA1600ED3353</b>	KT 3X1600AL PLUG-IN LENGTH	50	<b>KTA1600ER52</b>	KT 5X1600AL FEED UNIT ER N2	79
<b>KTA1600ED3403</b>	KT 3X1600AL PLUG-IN LENGTH 4M	50	<b>KTA1600ER53</b>	KT 5X1600AL FEED UNIT ER N3	80
<b>KTA1600ED4201</b>	KT 1X1600AL PLUG-IN LENGTH 2M	50	<b>KTA1600ER54</b>	KT 5X1600AL FEED UNIT ER N4	80
<b>KTA1600ED4203</b>	KT 4X1600AL PLUG-IN LENGTH 2M	50	<b>KTA1600ER55</b>	KT 5X1600AL FEED UNIT ER N5	81
<b>KTA1600ED4301</b>	KT 1X1600AL PLUG-IN LENGTH	50	<b>KTA1600ER56</b>	KT 5X1600AL FEED UNIT ER N6	81
<b>KTA1600ED4302</b>	KT 2X1600AL PLUG-IN LENGTH	50	<b>KTA1600ER57</b>	KT 5X1600AL FEED UNIT ER N7	85
<b>KTA1600ED4351</b>	KT 1X1600AL PLUG-IN LENGTH	50	<b>KTA1600ER71</b>	KT 5X1600AL FEED UNIT ER N1	79
<b>KTA1600ED4353</b>	KT 3X1600AL PLUG-IN LENGTH	50	<b>KTA1600ER72</b>	KT 5X1600AL FEED UNIT ER N2	79
<b>KTA1600ED4403</b>	KT 4X1600AL PLUG-IN LENGTH 4M	50	<b>KTA1600ER73</b>	KT 5X1600AL FEED UNIT ER N3	80
<b>KTA1600ED5201</b>	KT 1X1600AL PLUG-IN LENGTH 2M	50	<b>KTA1600ER74</b>	KT 5X1600AL FEED UNIT ER N4	80
<b>KTA1600ED5203</b>	KT 5X1600AL PLUG-IN LENGTH 2M	50			

## Index of catalogue numbers

Cat. no.	Designations	Pages	Cat. no.	Designations	Pages
KTA1600ER75	KT 5X1600AL FEED UNIT ER N5	81	KTA1600FP3E2	KT 3X1600AL FLAT ELBOW N2 FIRE	72
KTA1600ER76	KT 5X1600AL FEED UNIT ER N6	81	KTA1600FP4A1	KT 4X1600AL FLAT ELBOW N1 FIRE	72
KTA1600ER77	KT 5X1600AL FEED UNIT ER N7	85	KTA1600FP4A2	KT 4X1600AL FLAT ELBOW N2 FIRE	72
KTA1600ET31A	KT 3X1600AL FEEDER LENGTH	50	KTA1600FP4B1	KT 4X1600AL FLAT ELBOW N1 FIRE	72
KTA1600ET320	KT 3X1600AL FEEDER LENGTH 2M	50	KTA1600FP4B2	KT 4X1600AL FLAT ELBOW N2 FIRE	72
KTA1600ET32B	KT 3X1600AL FEEDER LENGTH	50	KTA1600FP4D1	KT 4X1600AL FLAT ELBOW N1 FIRE	72
KTA1600ET32C	KT 3X1600AL FEEDER LENGTH	50	KTA1600FP4D2	KT 4X1600AL FLAT ELBOW N2 FIRE	72
KTA1600ET33D	KT 3X1600AL FEEDER LENGTH	50	KTA1600FP4E1	KT 4X1600AL FLAT ELBOW N1 FIRE	72
KTA1600ET33E	KT 3X1600AL FEEDER LENGTH	50	KTA1600FP4E2	KT 4X1600AL FLAT ELBOW N2 FIRE	72
KTA1600ET33F	KT 3X1600AL FEEDER LENGTH	50	KTA1600FP5A1	KT 5X1600AL FLAT ELBOW N1 FIRE	72
KTA1600ET340	KT 3X1600AL FEEDER LENGTH 4M	50	KTA1600FP5A2	KT 5X1600AL FLAT ELBOW N2 FIRE	72
KTA1600ET41A	KT 4X1600AL FEEDER LENGTH	50	KTA1600FP5B1	KT 5X1600AL FLAT ELBOW N1 FIRE	72
KTA1600ET420	KT 4X1600AL FEEDER LENGTH 2M	50	KTA1600FP5B2	KT 5X1600AL FLAT ELBOW N2 FIRE	72
KTA1600ET42B	KT 4X1600AL FEEDER LENGTH	50	KTA1600FP5D1	KT 5X1600AL FLAT ELBOW N1 FIRE	72
KTA1600ET42C	KT 4X1600AL FEEDER LENGTH	50	KTA1600FP5D2	KT 5X1600AL FLAT ELBOW N2 FIRE	72
KTA1600ET43D	KT 4X1600AL FEEDER LENGTH	50	KTA1600FP5E1	KT 5X1600AL FLAT ELBOW N1 FIRE	72
KTA1600ET43E	KT 4X1600AL FEEDER LENGTH	50	KTA1600FP5E2	KT 5X1600AL FLAT ELBOW N2 FIRE	72
KTA1600ET43F	KT 4X1600AL FEEDER LENGTH	50	KTA1600FP7A1	KT 5X1600AL FLAT ELBOW N1 FIRE	72
KTA1600ET440	KT 4X1600AL FEEDER LENGTH 4M	50	KTA1600FP7A2	KT 5X1600AL FLAT ELBOW N2 FIRE	72
KTA1600ET51A	KT 5X1600AL FEEDER LENGTH	50	KTA1600FP7B1	KT 5X1600AL FLAT ELBOW N1 FIRE	72
KTA1600ET520	KT 5X1600AL FEEDER LENGTH 2M	50	KTA1600FP7B2	KT 5X1600AL FLAT ELBOW N2 FIRE	72
KTA1600ET52B	KT 5X1600AL FEEDER LENGTH	50	KTA1600FP7D1	KT 5X1600AL FLAT ELBOW N1 FIRE	72
KTA1600ET52C	KT 5X1600AL FEEDER LENGTH	50	KTA1600FP7D2	KT 5X1600AL FLAT ELBOW N2 FIRE	72
KTA1600ET53D	KT 5X1600AL FEEDER LENGTH	50	KTA1600FP7E1	KT 5X1600AL FLAT ELBOW N1 FIRE	72
KTA1600ET53E	KT 5X1600AL FEEDER LENGTH	50	KTA1600FP7E2	KT 5X1600AL FLAT ELBOW N2 FIRE	72
KTA1600ET53F	KT 5X1600AL FEEDER LENGTH	50	KTA1600FT31A	KT 3X1600AL FEEDER LENGTH FIRE	70
KTA1600ET540	KT 5X1600AL FEEDER LENGTH 4M	50	KTA1600FT320	KT 3X1600AL FEEDER LENGTH FIRE 2M	70
KTA1600ET71A	KT 5X1600AL FEEDER LENGTH	50	KTA1600FT32B	KT 3X1600AL FEEDER LENGTH FIRE	70
KTA1600ET720	KT 5X1600AL FEEDER LENGTH 2M	50	KTA1600FT32C	KT 3X1600AL FEEDER LENGTH FIRE	70
KTA1600ET72B	KT 5X1600AL FEEDER LENGTH	50	KTA1600FT33D	KT 3X1600AL FEEDER LENGTH FIRE	70
KTA1600ET72C	KT 5X1600AL FEEDER LENGTH	50	KTA1600FT33E	KT 3X1600AL FEEDER LENGTH FIRE	70
KTA1600ET73D	KT 5X1600AL FEEDER LENGTH	50	KTA1600FT33F	KT 3X1600AL FEEDER LENGTH FIRE	70
KTA1600ET73E	KT 5X1600AL FEEDER LENGTH	50	KTA1600FT340	KT 3X1600AL FEEDER LENGTH FIRE 4M	70
KTA1600ET73F	KT 5X1600AL FEEDER LENGTH	50	KTA1600FT41A	KT 4X1600AL FEEDER LENGTH FIRE	70
KTA1600ET740	KT 5X1600AL FEEDER LENGTH 4M	50	KTA1600FT420	KT 4X1600AL FEEDER LENGTH FIRE 2M	70
KTA1600FC3A	KT 3X1600AL EDGEWISE ELBOW	73	KTA1600FT42B	KT 4X1600AL FEEDER LENGTH FIRE	70
KTA1600FC3B	KT 3X1600AL EDGEWISE ELBOW	73	KTA1600FT42C	KT 4X1600AL FEEDER LENGTH FIRE	70
KTA1600FC3D	KT 3X1600AL EDGEWISE ELBOW	73	KTA1600FT43D	KT 4X1600AL FEEDER LENGTH FIRE	70
KTA1600FC3E	KT 3X1600AL EDGEWISE ELBOW	73	KTA1600FT43E	KT 4X1600AL FEEDER LENGTH FIRE	70
KTA1600FC4A	KT 4X1600AL EDGEWISE ELBOW	73	KTA1600FT43F	KT 4X1600AL FEEDER LENGTH FIRE	70
KTA1600FC4B	KT 4X1600AL EDGEWISE ELBOW	73	KTA1600FT440	KT 4X1600AL FEEDER LENGTH FIRE 4M	70
KTA1600FC4D	KT 4X1600AL EDGEWISE ELBOW	73	KTA1600FT51A	KT 5X1600AL FEEDER LENGTH FIRE	70
KTA1600FC4E	KT 4X1600AL EDGEWISE ELBOW	73	KTA1600FT520	KT 5X1600AL FEEDER LENGTH FIRE 2M	70
KTA1600FC5A	KT 5X1600AL EDGEWISE ELBOW	73	KTA1600FT52B	KT 5X1600AL FEEDER LENGTH FIRE	70
KTA1600FC5B	KT 5X1600AL EDGEWISE ELBOW	73	KTA1600FT52C	KT 5X1600AL FEEDER LENGTH FIRE	70
KTA1600FC5D	KT 5X1600AL EDGEWISE ELBOW	73	KTA1600FT53D	KT 5X1600AL FEEDER LENGTH FIRE	70
KTA1600FC5E	KT 5X1600AL EDGEWISE ELBOW	71	KTA1600FT53E	KT 5X1600AL FEEDER LENGTH FIRE	70
KTA1600FC7A	KT 5X1600AL EDGEWISE ELBOW	71	KTA1600FT53F	KT 5X1600AL FEEDER LENGTH FIRE	70
KTA1600FC7B	KT 5X1600AL EDGEWISE ELBOW	71	KTA1600FT540	KT 5X1600AL FEEDER LENGTH FIRE 4M	70
KTA1600FC7D	KT 5X1600AL EDGEWISE ELBOW	71	KTA1600FT71A	KT 5X1600AL FEEDER LENGTH FIRE	70
KTA1600FC7E	KT 5X1600AL EDGEWISE ELBOW	71	KTA1600FT720	KT 5X1600AL FEEDER LENGTH FIRE 2M	70
KTA1600FJ3	KT 3X1600AL JUNCTION BLOC FIRE RATED	73	KTA1600FT72B	KT 5X1600AL FEEDER LENGTH FIRE	70
KTA1600FJ4	KT 4X1600AL JUNCTION BLOC FIRE RATED	73	KTA1600FT72C	KT 5X1600AL FEEDER LENGTH FIRE	70
KTA1600FJ5	KT 5X1600AL JUNCTION BLOC FIRE RATED	73	KTA1600FT73D	KT 5X1600AL FEEDER LENGTH FIRE	70
KTA1600FJ6	KT 4X1600AL JUNCTION BLOC FIRE RATED	73	KTA1600FT73E	KT 5X1600AL FEEDER LENGTH FIRE	70
KTA1600FJ7	KT 5X1600AL JUNCTION BLOC FIRE RATED	73	KTA1600FT73F	KT 5X1600AL FEEDER LENGTH FIRE	70
KTA1600FP3A1	KT 3X1600AL FLAT ELBOW N1 FIRE	72	KTA1600FT740	KT 5X1600AL FEEDER LENGTH FIRE 4M	70
KTA1600FP3A2	KT 3X1600AL FLAT ELBOW N2 FIRE	72	KTA1600LC3A	KT 3X1600AL EDGEWISE ELBOW	61
KTA1600FP3B1	KT 3X1600AL FLAT ELBOW N1 FIRE	72	KTA1600LC3B	KT 3X1600AL EDGEWISE ELBOW	61
KTA1600FP3B2	KT 3X1600AL FLAT ELBOW N2 FIRE	72	KTA1600LC3D	KT 3X1600AL EDGEWISE ELBOW	61
KTA1600FP3D1	KT 3X1600AL FLAT ELBOW N1 FIRE	72	KTA1600LC3E	KT 3X1600AL EDGEWISE ELBOW	61
KTA1600FP3D2	KT 3X1600AL FLAT ELBOW N2 FIRE	72	KTA1600LC4A	KT 4X1600AL EDGEWISE ELBOW	61
KTA1600FP3E1	KT 3X1600AL FLAT ELBOW N1 FIRE	72	KTA1600LC4B	KT 4X1600AL EDGEWISE ELBOW	61

A

B

C

D

E

F

G

## Index of catalogue numbers

Cat. no.	Designations	Pages
<b>KTA1600LC4D</b>	KT 4X1600AL EDGEWISE ELBOW	61
<b>KTA1600LC4E</b>	KT 4X1600AL EDGEWISE ELBOW	61
<b>KTA1600LC5A</b>	KT 5X1600AL EDGEWISE ELBOW	61
<b>KTA1600LC5B</b>	KT 5X1600AL EDGEWISE ELBOW	61
<b>KTA1600LC5D</b>	KT 5X1600AL EDGEWISE ELBOW	61
<b>KTA1600LC5E</b>	KT 5X1600AL EDGEWISE ELBOW	61
<b>KTA1600LC7A</b>	KT 5X1600AL EDGEWISE ELBOW	61
<b>KTA1600LC7B</b>	KT 5X1600AL EDGEWISE ELBOW	61
<b>KTA1600LC7D</b>	KT 5X1600AL EDGEWISE ELBOW	61
<b>KTA1600LC7E</b>	KT 5X1600AL EDGEWISE ELBOW	61
<b>KTA1600LP3A1</b>	KT 3X1600AL FLAT ELBOW N1	60
<b>KTA1600LP3A2</b>	KT 3X1600AL FLAT ELBOW N2	60
<b>KTA1600LP3B1</b>	KT 3X1600AL FLAT ELBOW N1	60
<b>KTA1600LP3B2</b>	KT 3X1600AL FLAT ELBOW N2	60
<b>KTA1600LP3C1</b>	KT 3X1600AL FLAT ELBOW N1	61
<b>KTA1600LP3C2</b>	KT 3X1600AL FLAT ELBOW N2	61
<b>KTA1600LP3D1</b>	KT 3X1600AL FLAT ELBOW N1	60
<b>KTA1600LP3D2</b>	KT 3X1600AL FLAT ELBOW N2	60
<b>KTA1600LP3E1</b>	KT 3X1600AL FLAT ELBOW N1	60
<b>KTA1600LP3E2</b>	KT 3X1600AL FLAT ELBOW N2	60
<b>KTA1600LP4A1</b>	KT 4X1600AL FLAT ELBOW N1	60
<b>KTA1600LP4A2</b>	KT 4X1600AL FLAT ELBOW N2	60
<b>KTA1600LP4B1</b>	KT 4X1600AL FLAT ELBOW N1	60
<b>KTA1600LP4B2</b>	KT 4X1600AL FLAT ELBOW N2	60
<b>KTA1600LP4C1</b>	KT 4X1600AL FLAT ELBOW N1	61
<b>KTA1600LP4C2</b>	KT 4X1600AL FLAT ELBOW N2	61
<b>KTA1600LP4D1</b>	KT 4X1600AL FLAT ELBOW N1	60
<b>KTA1600LP4D2</b>	KT 4X1600AL FLAT ELBOW N2	60
<b>KTA1600LP4E1</b>	KT 4X1600AL FLAT ELBOW N1	60
<b>KTA1600LP4E2</b>	KT 4X1600AL FLAT ELBOW N2	60
<b>KTA1600LP5A1</b>	KT 5X1600AL FLAT ELBOW N1	60
<b>KTA1600LP5A2</b>	KT 5X1600AL FLAT ELBOW N2	60
<b>KTA1600LP5B1</b>	KT 5X1600AL FLAT ELBOW N1	60
<b>KTA1600LP5B2</b>	KT 5X1600AL FLAT ELBOW N2	60
<b>KTA1600LP5C1</b>	KT 5X1600AL FLAT ELBOW N1	61
<b>KTA1600LP5C2</b>	KT 5X1600AL FLAT ELBOW N2	61
<b>KTA1600LP5D1</b>	KT 5X1600AL FLAT ELBOW N1	60
<b>KTA1600LP5D2</b>	KT 5X1600AL FLAT ELBOW N2	60
<b>KTA1600LP5E1</b>	KT 5X1600AL FLAT ELBOW N1	60
<b>KTA1600LP5E2</b>	KT 5X1600AL FLAT ELBOW N2	60
<b>KTA1600LP7A1</b>	KT 5X1600AL FLAT ELBOW N1	60
<b>KTA1600LP7A2</b>	KT 5X1600AL FLAT ELBOW N2	60
<b>KTA1600LP7B1</b>	KT 5X1600AL FLAT ELBOW N1	60
<b>KTA1600LP7B2</b>	KT 5X1600AL FLAT ELBOW N2	60
<b>KTA1600LP7C1</b>	KT 5X1600AL FLAT ELBOW N1	61
<b>KTA1600LP7C2</b>	KT 5X1600AL FLAT ELBOW N2	61
<b>KTA1600LP7D1</b>	KT 5X1600AL FLAT ELBOW N1	60
<b>KTA1600LP7D2</b>	KT 5X1600AL FLAT ELBOW N2	60
<b>KTA1600LP7E1</b>	KT 5X1600AL FLAT ELBOW N1	60
<b>KTA1600LP7E2</b>	KT 5X1600AL FLAT ELBOW N2	60
<b>KTA1600PL31</b>	KT 3X1600AL LINE PROTECTOR NS	128
<b>KTA1600PL41</b>	KT 4X1600AL LINE PROTECTOR NS	128
<b>KTA1600PL51</b>	KT 5X1600AL LINE PROTECTOR NS	128
<b>KTA1600PL71</b>	KT 5X1600AL LINE PROTECTOR NS	128
<b>KTA1600SL31</b>	KT 3X1600AL ISOLATOR UNIT NA	125
<b>KTA1600SL41</b>	KT 4X1600AL ISOLATOR UNIT NA	125
<b>KTA1600SL51</b>	KT 5X1600AL ISOLATOR UNIT NA	125
<b>KTA1600SL71</b>	KT 5X1600AL ISOLATOR UNIT NA	125
<b>KTA1600TC3</b>	KT 3X1600AL TEE ON EDGE	65
<b>KTA1600TC4</b>	KT 4X1600AL TEE ON EDGE	65
<b>KTA1600TC5</b>	KT 5X1600AL TEE ON EDGE	65
<b>KTA1600TC7</b>	KT 5X1600AL TEE ON EDGE	65
<b>KTA1600TN410</b>	KT 4X1600AL NEUTRAL PERMUTA	56

Cat. no.	Designations	Pages
<b>KTA1600TN610</b>	KT 4X1600AL NEUTRAL PERMUTA	56
<b>KTA1600TP410</b>	KT 4X1600AL PHASES PERMUTA	56
<b>KTA1600TP610</b>	KT 4X1600AL PHASES PERMUTA	56
<b>KTA1600YA3</b>	KT 3X1600AL JUNCTION BLOC	58
<b>KTA1600YA4</b>	KT 4X1600AL JUNCTION BLOC	58
<b>KTA1600YA5</b>	KT 5X1600AL JUNCTION BLOC	58
<b>KTA1600YA6</b>	KT 4X1600AL JUNCTION BLOC	58
<b>KTA1600YA7</b>	KT 5X1600AL JUNCTION BLOC	58
<b>KTA1600ZC31</b>	KT 3X1600AL EDGEWISE ZED N1	66
<b>KTA1600ZC32</b>	KT 3X1600AL EDGEWISE ZED N2	66
<b>KTA1600ZC41</b>	KT 4X1600AL EDGEWISE ZED N1	66
<b>KTA1600ZC42</b>	KT 4X1600AL EDGEWISE ZED N2	66
<b>KTA1600ZC51</b>	KT 5X1600AL EDGEWISE ZED N1	66
<b>KTA1600ZC52</b>	KT 5X1600AL EDGEWISE ZED N2	66
<b>KTA1600ZC71</b>	KT 5X1600AL EDGEWISE ZED N1	66
<b>KTA1600ZC72</b>	KT 5X1600AL EDGEWISE ZED N2	66
<b>KTA1600ZP3</b>	KT 3X1600AL ZED ON FLAT	66
<b>KTA1600ZP4</b>	KT 4X1600AL ZED ON FLAT	66
<b>KTA1600ZP5</b>	KT 5X1600AL ZED ON FLAT	66
<b>KTA1600ZP7</b>	KT 5X1600AL ZED ON FLAT	66

**KTA2000**

<b>KTA2000CP31</b>	KT 3X2000AL FLAT EDGEWISE N1	68
<b>KTA2000CP32</b>	KT 3X2000AL FLAT EDGEWISE N2	68
<b>KTA2000CP33</b>	KT 3X2000AL FLAT EDGEWISE N3	68
<b>KTA2000CP34</b>	KT 3X2000AL FLAT EDGEWISE N4	68
<b>KTA2000CP41</b>	KT 4X2000AL FLAT EDGEWISE N1	68
<b>KTA2000CP42</b>	KT 4X2000AL FLAT EDGEWISE N2	68
<b>KTA2000CP43</b>	KT 4X2000AL FLAT EDGEWISE N3	68
<b>KTA2000CP44</b>	KT 4X2000AL FLAT EDGEWISE N4	68
<b>KTA2000CP51</b>	KT 5X2000AL FLAT EDGEWISE N1	68
<b>KTA2000CP52</b>	KT 5X2000AL FLAT EDGEWISE N2	68
<b>KTA2000CP53</b>	KT 5X2000AL FLAT EDGEWISE N3	68
<b>KTA2000CP54</b>	KT 5X2000AL FLAT EDGEWISE N4	68
<b>KTA2000CP71</b>	KT 5X2000AL FLAT EDGEWISE N1	68
<b>KTA2000CP72</b>	KT 5X2000AL FLAT EDGEWISE N2	68
<b>KTA2000CP73</b>	KT 5X2000AL FLAT EDGEWISE N3	68
<b>KTA2000CP74</b>	KT 5X2000AL FLAT EDGEWISE N4	68
<b>KTA2000DB310</b>	KT 3X2000AL EXPANSION UNIT	56
<b>KTA2000DB410</b>	KT 4X2000AL EXPANSION UNIT	56
<b>KTA2000DB510</b>	KT 5X2000AL EXPANSION UNIT	56
<b>KTA2000DB710</b>	KT 5X2000AL EXPANSION UNIT	56
<b>KTA2000EB320</b>	KT 3X2000AL BOLT ON LENGTH 2M	52
<b>KTA2000EB340</b>	KT 3X2000AL BOLT ON LENGTH 4M	52
<b>KTA2000EB420</b>	KT 4X2000AL BOLT ON LENGTH 2M	52
<b>KTA2000EB440</b>	KT 4X2000AL BOLT ON LENGTH 4M	52
<b>KTA2000EB520</b>	KT 5X2000AL BOLT ON LENGTH 2M	52
<b>KTA2000EB540</b>	KT 5X2000AL BOLT ON LENGTH 4M	52
<b>KTA2000EB720</b>	KT 5X2000AL BOLT ON LENGTH 2M	52
<b>KTA2000EB740</b>	KT 5X2000AL BOLT ON LENGTH 4M	52
<b>KTA2000ED3201</b>	KT 1X2000AL PLUG-IN LENGTH 2M	50
<b>KTA2000ED3203</b>	KT 3X2000AL PLUG-IN LENGTH 2M	50
<b>KTA2000ED3301</b>	KT 1X2000AL PLUG-IN LENGTH	50
<b>KTA2000ED3302</b>	KT 2X2000AL PLUG-IN LENGTH	50
<b>KTA2000ED3351</b>	KT 1X2000AL PLUG-IN LENGTH	50
<b>KTA2000ED3353</b>	KT 3X2000AL PLUG-IN LENGTH	50
<b>KTA2000ED3403</b>	KT 3X2000AL PLUG-IN LENGTH 4M	50
<b>KTA2000ED4201</b>	KT 1X2000AL PLUG-IN LENGTH 2M	50
<b>KTA2000ED4203</b>	KT 4X2000AL PLUG-IN LENGTH 2M	50
<b>KTA2000ED4301</b>	KT 1X2000AL PLUG-IN LENGTH	50
<b>KTA2000ED4302</b>	KT 2X2000AL PLUG-IN LENGTH	50
<b>KTA2000ED4351</b>	KT 1X2000AL PLUG-IN LENGTH	50
<b>KTA2000ED4353</b>	KT 3X2000AL PLUG-IN LENGTH	50

## Index of catalogue numbers

Cat. no.	Designations	Pages	Cat. no.	Designations	Pages
KTA2000ED4403	KT 4X2000AL PLUG-IN LENGTH 4M	50	KTA2000ER72	KT 5X2000AL FEED UNIT ER N2	79
KTA2000ED5201	KT 1X2000AL PLUG-IN LENGTH 2M	50	KTA2000ER73	KT 5X2000AL FEED UNIT ER N3	80
KTA2000ED5203	KT 5X2000AL PLUG-IN LENGTH 2M	50	KTA2000ER74	KT 5X2000AL FEED UNIT ER N4	80
KTA2000ED5301	KT 1X2000AL PLUG-IN LENGTH	50	KTA2000ER75	KT 5X2000AL FEED UNIT ER N5	81
KTA2000ED5302	KT 2X2000AL PLUG-IN LENGTH	50	KTA2000ER76	KT 5X2000AL FEED UNIT ER N6	81
KTA2000ED5351	KT 1X2000AL PLUG-IN LENGTH	50	KTA2000ER77	KT 5X2000AL FEED UNIT ER N7	85
KTA2000ED5353	KT 3X2000AL PLUG-IN LENGTH	50	KTA2000ET31A	KT 3X2000AL FEEDER LENGTH	50
KTA2000ED5403	KT 5X2000AL PLUG-IN LENGTH 4M	50	KTA2000ET320	KT 3X2000AL FEEDER LENGTH 2M	50
KTA2000ED7201	KT 1X2000AL PLUG-IN LENGTH 2M	50	KTA2000ET32B	KT 3X2000AL FEEDER LENGTH	50
KTA2000ED7203	KT 5X2000AL PLUG-IN LENGTH 2M	50	KTA2000ET32C	KT 3X2000AL FEEDER LENGTH	50
KTA2000ED7301	KT 1X2000AL PLUG-IN LENGTH	50	KTA2000ET33D	KT 3X2000AL FEEDER LENGTH	50
KTA2000ED7302	KT 2X2000AL PLUG-IN LENGTH	50	KTA2000ET33E	KT 3X2000AL FEEDER LENGTH	50
KTA2000ED7351	KT 1X2000AL PLUG-IN LENGTH	50	KTA2000ET33F	KT 3X2000AL FEEDER LENGTH	50
KTA2000ED7353	KT 3X2000AL PLUG-IN LENGTH	50	KTA2000ET340	KT 3X2000AL FEEDER LENGTH 4M	50
KTA2000ED7403	KT 5X2000AL PLUG-IN LENGTH 4M	50	KTA2000ET41A	KT 4X2000AL FEEDER LENGTH	50
KTA2000EH320	KT 3X2000AL KH PLUG-IN LENGTH 2M	53	KTA2000ET420	KT 4X2000AL FEEDER LENGTH 2M	50
KTA2000EH340	KT 3X2000AL KH PLUG-IN LENGTH 4M	53	KTA2000ET42B	KT 4X2000AL FEEDER LENGTH	50
KTA2000EH420	KT 4X2000AL KH PLUG-IN LENGTH 2M	53	KTA2000ET42C	KT 4X2000AL FEEDER LENGTH	50
KTA2000EH440	KT 4X2000AL KH PLUG-IN LENGTH 4M	53	KTA2000ET43D	KT 4X2000AL FEEDER LENGTH	50
KTA2000EH520	KT 5X2000AL KH PLUG-IN LENGTH 2M	53	KTA2000ET43E	KT 4X2000AL FEEDER LENGTH	50
KTA2000EH540	KT 5X2000AL KH PLUG-IN LENGTH 4M	53	KTA2000ET43F	KT 4X2000AL FEEDER LENGTH	50
KTA2000EL31	KT 3X2000AL FEED UNIT EL N1	92	KTA2000ET440	KT 4X2000AL FEEDER LENGTH 4M	50
KTA2000EL32	KT 3X2000AL FEED UNIT EL N2	92	KTA2000ET51A	KT 5X2000AL FEEDER LENGTH	50
KTA2000EL33	KT 3X2000AL FEED UNIT EL N3	94	KTA2000ET520	KT 5X2000AL FEEDER LENGTH 2M	50
KTA2000EL34	KT 3X2000AL FEED UNIT EL N4	94	KTA2000ET52B	KT 5X2000AL FEEDER LENGTH	50
KTA2000EL35	KT 3X2000AL FEED UNIT EL N5	95	KTA2000ET52C	KT 5X2000AL FEEDER LENGTH	50
KTA2000EL41	KT 4X2000AL FEED UNIT EL N1	92	KTA2000ET53D	KT 5X2000AL FEEDER LENGTH	50
KTA2000EL42	KT 4X2000AL FEED UNIT EL N2	92	KTA2000ET53E	KT 5X2000AL FEEDER LENGTH	50
KTA2000EL43	KT 4X2000AL FEED UNIT EL N3	94	KTA2000ET53F	KT 5X2000AL FEEDER LENGTH	50
KTA2000EL44	KT 4X2000AL FEED UNIT EL N4	94	KTA2000ET540	KT 5X2000AL FEEDER LENGTH 4M	50
KTA2000EL45	KT 4X2000AL FEED UNIT EL N5	95	KTA2000ET71A	KT 5X2000AL FEEDER LENGTH	50
KTA2000EL51	KT 5X2000AL FEED UNIT EL N1	92	KTA2000ET720	KT 5X2000AL FEEDER LENGTH 2M	50
KTA2000EL52	KT 5X2000AL FEED UNIT EL N2	92	KTA2000ET72B	KT 5X2000AL FEEDER LENGTH	50
KTA2000EL53	KT 5X2000AL FEED UNIT EL N3	94	KTA2000ET72C	KT 5X2000AL FEEDER LENGTH	50
KTA2000EL54	KT 5X2000AL FEED UNIT EL N4	94	KTA2000ET73D	KT 5X2000AL FEEDER LENGTH	50
KTA2000EL55	KT 5X2000AL FEED UNIT EL N5	95	KTA2000ET73E	KT 5X2000AL FEEDER LENGTH	50
KTA2000EL71	KT 5X2000AL FEED UNIT EL N1	92	KTA2000ET73F	KT 5X2000AL FEEDER LENGTH	50
KTA2000EL72	KT 5X2000AL FEED UNIT EL N2	92	KTA2000ET740	KT 5X2000AL FEEDER LENGTH 4M	50
KTA2000EL73	KT 5X2000AL FEED UNIT EL N3	94	KTA2000FC3A	KT 3X2000AL EDGEWISE ELBOW	73
KTA2000EL74	KT 5X2000AL FEED UNIT EL N4	94	KTA2000FC3B	KT 3X2000AL EDGEWISE ELBOW	73
KTA2000EL75	KT 5X2000AL FEED UNIT EL N5	95	KTA2000FC3D	KT 3X2000AL EDGEWISE ELBOW	73
KTA2000ER31	KT 3X2000AL FEED UNIT ER N1	79	KTA2000FC3E	KT 3X2000AL EDGEWISE ELBOW	73
KTA2000ER32	KT 3X2000AL FEED UNIT ER N2	79	KTA2000FC4A	KT 4X2000AL EDGEWISE ELBOW	73
KTA2000ER33	KT 3X2000AL FEED UNIT ER N3	80	KTA2000FC4B	KT 4X2000AL EDGEWISE ELBOW	73
KTA2000ER34	KT 3X2000AL FEED UNIT ER N4	80	KTA2000FC4D	KT 4X2000AL EDGEWISE ELBOW	73
KTA2000ER35	KT 3X2000AL FEED UNIT ER N5	81	KTA2000FC4E	KT 4X2000AL EDGEWISE ELBOW	73
KTA2000ER36	KT 3X2000AL FEED UNIT ER N6	81	KTA2000FC5A	KT 5X2000AL EDGEWISE ELBOW	73
KTA2000ER37	KT 3X2000AL FEED UNIT ER N7	85	KTA2000FC5B	KT 5X2000AL EDGEWISE ELBOW	73
KTA2000ER41	KT 4X2000AL FEED UNIT ER N1	79	KTA2000FC5D	KT 5X2000AL EDGEWISE ELBOW	73
KTA2000ER42	KT 4X2000AL FEED UNIT ER N2	79	KTA2000FC5E	KT 5X2000AL EDGEWISE ELBOW	73
KTA2000ER43	KT 4X2000AL FEED UNIT ER N3	80	KTA2000FC7A	KT 5X2000AL EDGEWISE ELBOW	73
KTA2000ER44	KT 4X2000AL FEED UNIT ER N4	80	KTA2000FC7B	KT 5X2000AL EDGEWISE ELBOW	73
KTA2000ER45	KT 4X2000AL FEED UNIT ER N5	81	KTA2000FC7D	KT 5X2000AL EDGEWISE ELBOW	73
KTA2000ER46	KT 4X2000AL FEED UNIT ER N6	81	KTA2000FC7E	KT 5X2000AL EDGEWISE ELBOW	73
KTA2000ER47	KT 4X2000AL FEED UNIT ER N7	85	KTA2000FJ3	KT 3X2000AL JUNCTION BLOC FIRE RATED	71
KTA2000ER51	KT 5X2000AL FEED UNIT ER N1	79	KTA2000FJ4	KT 4X2000AL JUNCTION BLOC FIRE RATED	71
KTA2000ER52	KT 5X2000AL FEED UNIT ER N2	79	KTA2000FJ5	KT 5X2000AL JUNCTION BLOC FIRE RATED	71
KTA2000ER53	KT 5X2000AL FEED UNIT ER N3	80	KTA2000FJ6	KT 4X2000AL JUNCTION BLOC FIRE RATED	71
KTA2000ER54	KT 5X2000AL FEED UNIT ER N4	80	KTA2000FJ7	KT 5X2000AL JUNCTION BLOC FIRE RATED	71
KTA2000ER55	KT 5X2000AL FEED UNIT ER N5	81	KTA2000FP3A1	KT 3X2000AL FLAT ELBOW N1 FIRE	72
KTA2000ER56	KT 5X2000AL FEED UNIT ER N6	81	KTA2000FP3A2	KT 3X2000AL FLAT ELBOW N2 FIRE	72
KTA2000ER57	KT 5X2000AL FEED UNIT ER N7	85	KTA2000FP3B1	KT 3X2000AL FLAT ELBOW N1 FIRE	72
KTA2000ER71	KT 5X2000AL FEED UNIT ER N1	79	KTA2000FP3B2	KT 3X2000AL FLAT ELBOW N2 FIRE	72

A

B

C

D

E

F

G

## Index of catalogue numbers

Cat. no.	Designations	Pages	Cat. no.	Designations	Pages
<b>A</b>					
KTA2000FP3D1	KT 3X2000AL FLAT ELBOW N1 FIRE	72	KTA2000LC3E	KT 3X2000AL EDGEWISE ELBOW	61
KTA2000FP3D2	KT 3X2000AL FLAT ELBOW N2 FIRE	72	KTA2000LC4A	KT 4X2000AL EDGEWISE ELBOW	61
KTA2000FP3E1	KT 3X2000AL FLAT ELBOW N1 FIRE	72	KTA2000LC4B	KT 4X2000AL EDGEWISE ELBOW	61
KTA2000FP3E2	KT 3X2000AL FLAT ELBOW N2 FIRE	72	KTA2000LC4D	KT 4X2000AL EDGEWISE ELBOW	61
KTA2000FP4A1	KT 4X2000AL FLAT ELBOW N1 FIRE	72	KTA2000LC4E	KT 4X2000AL EDGEWISE ELBOW	61
KTA2000FP4A2	KT 4X2000AL FLAT ELBOW N2 FIRE	72	KTA2000LC5A	KT 5X2000AL EDGEWISE ELBOW	61
KTA2000FP4B1	KT 4X2000AL FLAT ELBOW N1 FIRE	72	KTA2000LC5B	KT 5X2000AL EDGEWISE ELBOW	61
KTA2000FP4B2	KT 4X2000AL FLAT ELBOW N2 FIRE	72	KTA2000LC5D	KT 5X2000AL EDGEWISE ELBOW	61
KTA2000FP4D1	KT 4X2000AL FLAT ELBOW N1 FIRE	72	KTA2000LC5E	KT 5X2000AL EDGEWISE ELBOW	61
KTA2000FP4D2	KT 4X2000AL FLAT ELBOW N2 FIRE	72	KTA2000LC7A	KT 5X2000AL EDGEWISE ELBOW	61
KTA2000FP4E1	KT 4X2000AL FLAT ELBOW N1 FIRE	72	KTA2000LC7B	KT 5X2000AL EDGEWISE ELBOW	61
KTA2000FP4E2	KT 4X2000AL FLAT ELBOW N2 FIRE	72	KTA2000LC7D	KT 5X2000AL EDGEWISE ELBOW	61
KTA2000FP5A1	KT 5X2000AL FLAT ELBOW N1 FIRE	72	KTA2000LC7E	KT 5X2000AL EDGEWISE ELBOW	61
KTA2000FP5A2	KT 5X2000AL FLAT ELBOW N2 FIRE	72	KTA2000LP3A1	KT 3X2000AL FLAT ELBOW N1	60
KTA2000FP5B1	KT 5X2000AL FLAT ELBOW N1 FIRE	72	KTA2000LP3A2	KT 3X2000AL FLAT ELBOW N2	60
KTA2000FP5B2	KT 5X2000AL FLAT ELBOW N2 FIRE	72	KTA2000LP3B1	KT 3X2000AL FLAT ELBOW N1	60
KTA2000FP5D1	KT 5X2000AL FLAT ELBOW N1 FIRE	72	KTA2000LP3B2	KT 3X2000AL FLAT ELBOW N2	60
KTA2000FP5D2	KT 5X2000AL FLAT ELBOW N2 FIRE	72	KTA2000LP3C1	KT 3X2000AL FLAT ELBOW N1	61
KTA2000FP5E1	KT 5X2000AL FLAT ELBOW N1 FIRE	72	KTA2000LP3C2	KT 3X2000AL FLAT ELBOW N2	61
KTA2000FP5E2	KT 5X2000AL FLAT ELBOW N2 FIRE	72	KTA2000LP3D1	KT 3X2000AL FLAT ELBOW N1	60
KTA2000FP7A1	KT 5X2000AL FLAT ELBOW N1 FIRE	72	KTA2000LP3D2	KT 3X2000AL FLAT ELBOW N2	60
KTA2000FP7A2	KT 5X2000AL FLAT ELBOW N2 FIRE	72	KTA2000LP3E1	KT 3X2000AL FLAT ELBOW N1	60
KTA2000FP7B1	KT 5X2000AL FLAT ELBOW N1 FIRE	72	KTA2000LP3E2	KT 3X2000AL FLAT ELBOW N2	60
KTA2000FP7B2	KT 5X2000AL FLAT ELBOW N2 FIRE	72	KTA2000LP4A1	KT 4X2000AL FLAT ELBOW N1	60
KTA2000FP7D1	KT 5X2000AL FLAT ELBOW N1 FIRE	72	KTA2000LP4A2	KT 4X2000AL FLAT ELBOW N2	60
KTA2000FP7D2	KT 5X2000AL FLAT ELBOW N2 FIRE	72	KTA2000LP4B1	KT 4X2000AL FLAT ELBOW N1	60
KTA2000FP7E1	KT 5X2000AL FLAT ELBOW N1 FIRE	72	KTA2000LP4B2	KT 4X2000AL FLAT ELBOW N2	60
KTA2000FP7E2	KT 5X2000AL FLAT ELBOW N2 FIRE	72	KTA2000LP4C1	KT 4X2000AL FLAT ELBOW N1	61
KTA2000FT31A	KT 3X2000AL FEEDER LENGTH FIRE	70	KTA2000LP4C2	KT 4X2000AL FLAT ELBOW N2	61
KTA2000FT320	KT 3X2000AL FEEDER LENGTH FIRE 2M	70	KTA2000LP4D1	KT 4X2000AL FLAT ELBOW N1	60
KTA2000FT32B	KT 3X2000AL FEEDER LENGTH FIRE	70	KTA2000LP4D2	KT 4X2000AL FLAT ELBOW N2	60
KTA2000FT32C	KT 3X2000AL FEEDER LENGTH FIRE	70	KTA2000LP4E1	KT 4X2000AL FLAT ELBOW N1	60
KTA2000FT33D	KT 3X2000AL FEEDER LENGTH FIRE	70	KTA2000LP4E2	KT 4X2000AL FLAT ELBOW N2	60
KTA2000FT33E	KT 3X2000AL FEEDER LENGTH FIRE	70	KTA2000LP5A1	KT 5X2000AL FLAT ELBOW N1	60
KTA2000FT33F	KT 3X2000AL FEEDER LENGTH FIRE	70	KTA2000LP5A2	KT 5X2000AL FLAT ELBOW N2	60
KTA2000FT340	KT 3X2000AL FEEDER LENGTH FIRE 4M	70	KTA2000LP5B1	KT 5X2000AL FLAT ELBOW N1	60
KTA2000FT41A	KT 4X2000AL FEEDER LENGTH FIRE	70	KTA2000LP5B2	KT 5X2000AL FLAT ELBOW N2	60
KTA2000FT420	KT 4X2000AL FEEDER LENGTH FIRE 2M	70	KTA2000LP5C1	KT 5X2000AL FLAT ELBOW N1	61
KTA2000FT42B	KT 4X2000AL FEEDER LENGTH FIRE	70	KTA2000LP5C2	KT 5X2000AL FLAT ELBOW N2	61
KTA2000FT42C	KT 4X2000AL FEEDER LENGTH FIRE	70	KTA2000LP5D1	KT 5X2000AL FLAT ELBOW N1	60
KTA2000FT43D	KT 4X2000AL FEEDER LENGTH FIRE	70	KTA2000LP5D2	KT 5X2000AL FLAT ELBOW N2	60
KTA2000FT43E	KT 4X2000AL FEEDER LENGTH FIRE	70	KTA2000LP5E1	KT 5X2000AL FLAT ELBOW N1	60
KTA2000FT43F	KT 4X2000AL FEEDER LENGTH FIRE	70	KTA2000LP5E2	KT 5X2000AL FLAT ELBOW N2	60
KTA2000FT440	KT 4X2000AL FEEDER LENGTH FIRE 4M	70	KTA2000LP7A1	KT 5X2000AL FLAT ELBOW N1	60
KTA2000FT51A	KT 5X2000AL FEEDER LENGTH FIRE	70	KTA2000LP7A2	KT 5X2000AL FLAT ELBOW N2	60
KTA2000FT520	KT 5X2000AL FEEDER LENGTH FIRE 2M	70	KTA2000LP7B1	KT 5X2000AL FLAT ELBOW N1	60
KTA2000FT52B	KT 5X2000AL FEEDER LENGTH FIRE	70	KTA2000LP7B2	KT 5X2000AL FLAT ELBOW N2	60
KTA2000FT52C	KT 5X2000AL FEEDER LENGTH FIRE	70	KTA2000LP7C1	KT 5X2000AL FLAT ELBOW N1	61
KTA2000FT53D	KT 5X2000AL FEEDER LENGTH FIRE	70	KTA2000LP7C2	KT 5X2000AL FLAT ELBOW N2	61
KTA2000FT53E	KT 5X2000AL FEEDER LENGTH FIRE	70	KTA2000LP7D1	KT 5X2000AL FLAT ELBOW N1	60
KTA2000FT53F	KT 5X2000AL FEEDER LENGTH FIRE	70	KTA2000LP7D2	KT 5X2000AL FLAT ELBOW N2	60
KTA2000FT540	KT 5X2000AL FEEDER LENGTH FIRE 4M	70	KTA2000LP7E1	KT 5X2000AL FLAT ELBOW N1	60
KTA2000FT71A	KT 5X2000AL FEEDER LENGTH FIRE	70	KTA2000LP7E2	KT 5X2000AL FLAT ELBOW N2	60
KTA2000FT720	KT 5X2000AL FEEDER LENGTH FIRE 2M	70	KTA2000SL31	KT 3X2000AL ISOLATOR UNIT INV	125
KTA2000FT72B	KT 5X2000AL FEEDER LENGTH FIRE	70	KTA2000SL41	KT 4X2000AL ISOLATOR UNIT INV	125
KTA2000FT72C	KT 5X2000AL FEEDER LENGTH FIRE	70	KTA2000SL51	KT 5X2000AL ISOLATOR UNIT INV	125
KTA2000FT73D	KT 5X2000AL FEEDER LENGTH FIRE	70	KTA2000TC3	KT 3X2000AL TEE ON EDGE	65
KTA2000FT73E	KT 5X2000AL FEEDER LENGTH FIRE	70	KTA2000TC4	KT 4X2000AL TEE ON EDGE	65
KTA2000FT73F	KT 5X2000AL FEEDER LENGTH FIRE	70	KTA2000TC5	KT 5X2000AL TEE ON EDGE	65
KTA2000FT740	KT 5X2000AL FEEDER LENGTH FIRE 4M	70	KTA2000TC7	KT 5X2000AL TEE ON EDGE	65
KTA2000LC3A	KT 3X2000AL EDGEWISE ELBOW	61	KTA2000TN410	KT 4X2000AL NEUTRAL PERMUTA	56
KTA2000LC3B	KT 3X2000AL EDGEWISE ELBOW	61	KTA2000TN610	KT 4X2000AL NEUTRAL PERMUTA	56
KTA2000LC3D	KT 3X2000AL EDGEWISE ELBOW	61	KTA2000TP410	KT 4X2000AL PHASES PERMUTA	56

## Index of catalogue numbers

Cat. no.	Designations	Pages	Cat. no.	Designations	Pages
<b>KTA2000TP610</b>	KT 4X2000AL PHASES PERMUTA	56	<b>KTA2500ED4203</b>	KT 4X2500AL PLUG-IN LENGTH 2M	50
<b>KTA2000YA3</b>	KT 3X2000AL JUNCTION BLOC	58	<b>KTA2500ED4301</b>	KT 1X2500AL PLUG-IN LENGTH	50
<b>KTA2000YA4</b>	KT 4X2000AL JUNCTION BLOC	58	<b>KTA2500ED4302</b>	KT 2X2500AL PLUG-IN LENGTH	50
<b>KTA2000YA5</b>	KT 5X2000AL JUNCTION BLOC	58	<b>KTA2500ED4351</b>	KT 1X2500AL PLUG-IN LENGTH	50
<b>KTA2000YA6</b>	KT 4X2000AL JUNCTION BLOC	58	<b>KTA2500ED4353</b>	KT 3X2500AL PLUG-IN LENGTH	50
<b>KTA2000YA7</b>	KT 5X2000AL JUNCTION BLOC	58	<b>KTA2500ED4403</b>	KT 4X2500AL PLUG-IN LENGTH 4M	50
<b>KTA2000ZC31</b>	KT 3X2000AL EDGEWISE ZED N1	66	<b>KTA2500ED5201</b>	KT 1X2500AL PLUG-IN LENGTH 2M	50
<b>KTA2000ZC32</b>	KT 3X2000AL EDGEWISE ZED N2	66	<b>KTA2500ED5203</b>	KT 5X2500AL PLUG-IN LENGTH 2M	50
<b>KTA2000ZC41</b>	KT 4X2000AL EDGEWISE ZED N1	66	<b>KTA2500ED5301</b>	KT 1X2500AL PLUG-IN LENGTH	50
<b>KTA2000ZC42</b>	KT 4X2000AL EDGEWISE ZED N2	66	<b>KTA2500ED5302</b>	KT 2X2500AL PLUG-IN LENGTH	50
<b>KTA2000ZC51</b>	KT 5X2000AL EDGEWISE ZED N1	66	<b>KTA2500ED5351</b>	KT 1X2500AL PLUG-IN LENGTH	50
<b>KTA2000ZC52</b>	KT 5X2000AL EDGEWISE ZED N2	66	<b>KTA2500ED5353</b>	KT 3X2500AL PLUG-IN LENGTH	50
<b>KTA2000ZC71</b>	KT 5X2000AL EDGEWISE ZED N1	66	<b>KTA2500ED5403</b>	KT 5X2500AL PLUG-IN LENGTH 4M	50
<b>KTA2000ZC72</b>	KT 5X2000AL EDGEWISE ZED N2	66	<b>KTA2500ED6201</b>	KT 1X2500AL PLUG-IN LENGTH 2M	50
<b>KTA2000ZP3</b>	KT 3X2000AL ZED ON FLAT	66	<b>KTA2500ED6203</b>	KT 4X2500AL PLUG-IN LENGTH 2M	50
<b>KTA2000ZP4</b>	KT 4X2000AL ZED ON FLAT	66	<b>KTA2500ED6301</b>	KT 1X2500AL PLUG-IN LENGTH	50
<b>KTA2000ZP5</b>	KT 5X2000AL ZED ON FLAT	66	<b>KTA2500ED6302</b>	KT 2X2500AL PLUG-IN LENGTH	50
<b>KTA2000ZP7</b>	KT 5X2000AL ZED ON FLAT	66	<b>KTA2500ED6351</b>	KT 1X2500AL PLUG-IN LENGTH	50
			<b>KTA2500ED6353</b>	KT 3X2500AL PLUG-IN LENGTH	50
			<b>KTA2500ED6403</b>	KT 4X2500AL PLUG-IN LENGTH 4M	50
<b>KTA2500</b>			<b>KTA2500ED7201</b>	KT 1X2500AL PLUG-IN LENGTH 2M	50
<b>KTA2500CP31</b>	KT 3X2500AL FLAT EDGEWISE N1	68	<b>KTA2500ED7203</b>	KT 5X2500AL PLUG-IN LENGTH 2M	50
<b>KTA2500CP32</b>	KT 3X2500AL FLAT EDGEWISE N2	68	<b>KTA2500ED7301</b>	KT 1X2500AL PLUG-IN LENGTH	50
<b>KTA2500CP33</b>	KT 3X2500AL FLAT EDGEWISE N3	68	<b>KTA2500ED7302</b>	KT 2X2500AL PLUG-IN LENGTH	50
<b>KTA2500CP34</b>	KT 3X2500AL FLAT EDGEWISE N4	68	<b>KTA2500ED7351</b>	KT 1X2500AL PLUG-IN LENGTH	50
<b>KTA2500CP41</b>	KT 4X2500AL FLAT EDGEWISE N1	68	<b>KTA2500ED7353</b>	KT 3X2500AL PLUG-IN LENGTH	50
<b>KTA2500CP42</b>	KT 4X2500AL FLAT EDGEWISE N2	68	<b>KTA2500ED7403</b>	KT 5X2500AL PLUG-IN LENGTH 4M	50
<b>KTA2500CP43</b>	KT 4X2500AL FLAT EDGEWISE N3	68	<b>KTA2500EH320</b>	KT 3X2500AL KH PLUG-IN LENGTH 2M	53
<b>KTA2500CP44</b>	KT 4X2500AL FLAT EDGEWISE N4	68	<b>KTA2500EH340</b>	KT 3X2500AL KH PLUG-IN LENGTH 4M	53
<b>KTA2500CP51</b>	KT 5X2500AL FLAT EDGEWISE N1	68	<b>KTA2500EH420</b>	KT 4X2500AL KH PLUG-IN LENGTH 2M	53
<b>KTA2500CP52</b>	KT 5X2500AL FLAT EDGEWISE N2	68	<b>KTA2500EH440</b>	KT 4X2500AL KH PLUG-IN LENGTH 4M	53
<b>KTA2500CP53</b>	KT 5X2500AL FLAT EDGEWISE N3	68	<b>KTA2500EH520</b>	KT 5X2500AL KH PLUG-IN LENGTH 2M	53
<b>KTA2500CP54</b>	KT 5X2500AL FLAT EDGEWISE N4	68	<b>KTA2500EH540</b>	KT 5X2500AL KH PLUG-IN LENGTH 4M	53
<b>KTA2500CP61</b>	KT 4X2500AL FLAT EDGEWISE N1	68	<b>KTA2500EH620</b>	KT 4X2500AL KH PLUG-IN LENGTH 2M	53
<b>KTA2500CP62</b>	KT 4X2500AL FLAT EDGEWISE N2	68	<b>KTA2500EH640</b>	KT 4X2500AL KH PLUG-IN LENGTH 4M	53
<b>KTA2500CP63</b>	KT 4X2500AL FLAT EDGEWISE N3	68	<b>KTA2500EH720</b>	KT 5X2500AL KH PLUG-IN LENGTH 2M	53
<b>KTA2500CP64</b>	KT 4X2500AL FLAT EDGEWISE N4	68	<b>KTA2500EH740</b>	KT 5X2500AL KH PLUG-IN LENGTH 4M	53
<b>KTA2500CP71</b>	KT 5X2500AL FLAT EDGEWISE N1	68	<b>KTA2500EL31</b>	KT 3X2500AL FEED UNIT EL N1	92
<b>KTA2500CP72</b>	KT 5X2500AL FLAT EDGEWISE N2	68	<b>KTA2500EL32</b>	KT 3X2500AL FEED UNIT EL N2	92
<b>KTA2500CP73</b>	KT 5X2500AL FLAT EDGEWISE N3	68	<b>KTA2500EL33</b>	KT 3X2500AL FEED UNIT EL N3	94
<b>KTA2500CP74</b>	KT 5X2500AL FLAT EDGEWISE N4	68	<b>KTA2500EL34</b>	KT 3X2500AL FEED UNIT EL N4	94
<b>KTA2500DB310</b>	KT 3X2500AL EXPANSION UNIT	56	<b>KTA2500EL35</b>	KT 3X2500AL FEED UNIT EL N5	95
<b>KTA2500DB410</b>	KT 4X2500AL EXPANSION UNIT	56	<b>KTA2500EL41</b>	KT 4X2500AL FEED UNIT EL N1	92
<b>KTA2500DB510</b>	KT 5X2500AL EXPANSION UNIT	56	<b>KTA2500EL42</b>	KT 4X2500AL FEED UNIT EL N2	92
<b>KTA2500DB610</b>	KT 4X2500AL EXPANSION UNIT	56	<b>KTA2500EL43</b>	KT 4X2500AL FEED UNIT EL N3	94
<b>KTA2500DB710</b>	KT 5X2500AL EXPANSION UNIT	56	<b>KTA2500EL44</b>	KT 4X2500AL FEED UNIT EL N4	94
<b>KTA2500EB320</b>	KT 3X2500AL BOLT ON LENGTH 2M	52	<b>KTA2500EL45</b>	KT 4X2500AL FEED UNIT EL N5	95
<b>KTA2500EB340</b>	KT 3X2500AL BOLT ON LENGTH 4M	52	<b>KTA2500EL51</b>	KT 5X2500AL FEED UNIT EL N1	92
<b>KTA2500EB420</b>	KT 4X2500AL BOLT ON LENGTH 2M	52	<b>KTA2500EL52</b>	KT 5X2500AL FEED UNIT EL N2	92
<b>KTA2500EB440</b>	KT 4X2500AL BOLT ON LENGTH 4M	52	<b>KTA2500EL53</b>	KT 5X2500AL FEED UNIT EL N3	94
<b>KTA2500EB520</b>	KT 5X2500AL BOLT ON LENGTH 2M	52	<b>KTA2500EL54</b>	KT 5X2500AL FEED UNIT EL N4	94
<b>KTA2500EB540</b>	KT 5X2500AL BOLT ON LENGTH 4M	52	<b>KTA2500EL55</b>	KT 5X2500AL FEED UNIT EL N5	95
<b>KTA2500EB620</b>	KT 4X2500AL BOLT ON LENGTH 2M	52	<b>KTA2500EL61</b>	KT 4X2500AL FEED UNIT EL N1	92
<b>KTA2500EB640</b>	KT 4X2500AL BOLT ON LENGTH 4M	52	<b>KTA2500EL62</b>	KT 4X2500AL FEED UNIT EL N2	92
<b>KTA2500EB720</b>	KT 5X2500AL BOLT ON LENGTH 2M	52	<b>KTA2500EL63</b>	KT 4X2500AL FEED UNIT EL N3	94
<b>KTA2500EB740</b>	KT 5X2500AL BOLT ON LENGTH 4M	52	<b>KTA2500EL64</b>	KT 4X2500AL FEED UNIT EL N4	94
<b>KTA2500ED3201</b>	KT 1X2500AL PLUG-IN LENGTH 2M	50	<b>KTA2500EL65</b>	KT 4X2500AL FEED UNIT EL N5	95
<b>KTA2500ED3203</b>	KT 3X2500AL PLUG-IN LENGTH 2M	50	<b>KTA2500EL71</b>	KT 5X2500AL FEED UNIT EL N1	92
<b>KTA2500ED3301</b>	KT 1X2500AL PLUG-IN LENGTH	50	<b>KTA2500EL72</b>	KT 5X2500AL FEED UNIT EL N2	92
<b>KTA2500ED3302</b>	KT 2X2500AL PLUG-IN LENGTH	50	<b>KTA2500EL73</b>	KT 5X2500AL FEED UNIT EL N3	94
<b>KTA2500ED3351</b>	KT 1X2500AL PLUG-IN LENGTH	50	<b>KTA2500EL74</b>	KT 5X2500AL FEED UNIT EL N4	94
<b>KTA2500ED3353</b>	KT 3X2500AL PLUG-IN LENGTH	50	<b>KTA2500EL75</b>	KT 5X2500AL FEED UNIT EL N5	95
<b>KTA2500ED3403</b>	KT 3X2500AL PLUG-IN LENGTH 4M	50	<b>KTA2500ER31</b>	KT 3X2500AL FEED UNIT ER N1	79
<b>KTA2500ED4201</b>	KT 1X2500AL PLUG-IN LENGTH 2M	50			

## Index of catalogue numbers

Cat. no.	Designations	Pages	Cat. no.	Designations	Pages
<b>A</b>					
KTA2500ER32	KT 3X2500AL FEED UNIT ER N2	79	KTA2500ET63E	KT 4X2500AL FEEDER LENGTH	50
KTA2500ER33	KT 3X2500AL FEED UNIT ER N3	80	KTA2500ET63F	KT 4X2500AL FEEDER LENGTH	50
KTA2500ER34	KT 3X2500AL FEED UNIT ER N4	80	KTA2500ET640	KT 4X2500AL FEEDER LENGTH 4M	50
KTA2500ER35	KT 3X2500AL FEED UNIT ER N5	81	KTA2500ET71A	KT 5X2500AL FEEDER LENGTH	50
KTA2500ER36	KT 3X2500AL FEED UNIT ER N6	81	KTA2500ET720	KT 5X2500AL FEEDER LENGTH 2M	50
KTA2500ER37	KT 3X2500AL FEED UNIT ER N7	85	KTA2500ET72B	KT 5X2500AL FEEDER LENGTH	50
<b>B</b>			KTA2500ET72C	KT 5X2500AL FEEDER LENGTH	50
KTA2500ER41	KT 4X2500AL FEED UNIT ER N1	79	KTA2500ET73D	KT 5X2500AL FEEDER LENGTH	50
KTA2500ER42	KT 4X2500AL FEED UNIT ER N2	79	KTA2500ET73E	KT 5X2500AL FEEDER LENGTH	50
KTA2500ER43	KT 4X2500AL FEED UNIT ER N3	80	KTA2500ET73F	KT 5X2500AL FEEDER LENGTH	50
KTA2500ER44	KT 4X2500AL FEED UNIT ER N4	80	KTA2500ET740	KT 5X2500AL FEEDER LENGTH 4M	50
KTA2500ER45	KT 4X2500AL FEED UNIT ER N5	81	KTA2500FC3A	KT 3X2500AL EDGEWISE ELBOW	73
KTA2500ER46	KT 4X2500AL FEED UNIT ER N6	81	KTA2500FC3B	KT 3X2500AL EDGEWISE ELBOW	73
KTA2500ER47	KT 4X2500AL FEED UNIT ER N7	85	KTA2500FC3D	KT 3X2500AL EDGEWISE ELBOW	73
<b>C</b>			KTA2500FC3E	KT 3X2500AL EDGEWISE ELBOW	73
KTA2500ER51	KT 5X2500AL FEED UNIT ER N1	79	KTA2500FC4A	KT 4X2500AL EDGEWISE ELBOW	73
KTA2500ER52	KT 5X2500AL FEED UNIT ER N2	79	KTA2500FC4B	KT 4X2500AL EDGEWISE ELBOW	73
KTA2500ER53	KT 5X2500AL FEED UNIT ER N3	80	KTA2500FC4D	KT 4X2500AL EDGEWISE ELBOW	73
KTA2500ER54	KT 5X2500AL FEED UNIT ER N4	80	KTA2500FC4E	KT 4X2500AL EDGEWISE ELBOW	73
KTA2500ER55	KT 5X2500AL FEED UNIT ER N5	81	KTA2500FC5A	KT 5X2500AL EDGEWISE ELBOW	73
KTA2500ER56	KT 5X2500AL FEED UNIT ER N6	81	KTA2500FC5B	KT 5X2500AL EDGEWISE ELBOW	73
KTA2500ER57	KT 5X2500AL FEED UNIT ER N7	85	KTA2500FC5D	KT 5X2500AL EDGEWISE ELBOW	73
<b>D</b>			KTA2500FC5E	KT 5X2500AL EDGEWISE ELBOW	73
KTA2500ER61	KT 4X2500AL FEED UNIT ER N1	79	KTA2500FC6A	KT 4X2500AL EDGEWISE ELBOW	73
KTA2500ER62	KT 4X2500AL FEED UNIT ER N2	79	KTA2500FC6B	KT 4X2500AL EDGEWISE ELBOW	73
KTA2500ER63	KT 4X2500AL FEED UNIT ER N3	80	KTA2500FC6D	KT 4X2500AL EDGEWISE ELBOW	73
KTA2500ER64	KT 4X2500AL FEED UNIT ER N4	80	KTA2500FC6E	KT 4X2500AL EDGEWISE ELBOW	73
KTA2500ER65	KT 4X2500AL FEED UNIT ER N5	81	KTA2500FC7A	KT 5X2500AL EDGEWISE ELBOW	73
KTA2500ER66	KT 4X2500AL FEED UNIT ER N6	81	KTA2500FC7B	KT 5X2500AL EDGEWISE ELBOW	73
KTA2500ER67	KT 4X2500AL FEED UNIT ER N7	85	KTA2500FC7D	KT 5X2500AL EDGEWISE ELBOW	73
KTA2500ER71	KT 5X2500AL FEED UNIT ER N1	79	KTA2500FC7E	KT 5X2500AL EDGEWISE ELBOW	73
KTA2500ER72	KT 5X2500AL FEED UNIT ER N2	79	KTA2500FJ3	KT 3X2500AL JUNCTION BLOC FIRE RATED	71
KTA2500ER73	KT 5X2500AL FEED UNIT ER N3	80	KTA2500FJ4	KT 4X2500AL JUNCTION BLOC FIRE RATED	71
KTA2500ER74	KT 5X2500AL FEED UNIT ER N4	80	KTA2500FJ5	KT 5X2500AL JUNCTION BLOC FIRE RATED	71
KTA2500ER75	KT 5X2500AL FEED UNIT ER N5	81	KTA2500FJ6	KT 4X2500AL JUNCTION BLOC FIRE RATED	71
KTA2500ER76	KT 5X2500AL FEED UNIT ER N6	81	KTA2500FJ7	KT 5X2500AL JUNCTION BLOC FIRE RATED	71
KTA2500ER77	KT 5X2500AL FEED UNIT ER N7	85	KTA2500FP3A1	KT 3X2500AL FLAT ELBOW N1 FIRE	72
<b>E</b>			KTA2500FP3A2	KT 3X2500AL FLAT ELBOW N2 FIRE	72
KTA2500ET31A	KT 3X2500AL FEEDER LENGTH	50	KTA2500FP3B1	KT 3X2500AL FLAT ELBOW N1 FIRE	72
KTA2500ET320	KT 3X2500AL FEEDER LENGTH 2M	50	KTA2500FP3B2	KT 3X2500AL FLAT ELBOW N2 FIRE	72
KTA2500ET32B	KT 3X2500AL FEEDER LENGTH	50	KTA2500FP3D1	KT 3X2500AL FLAT ELBOW N1 FIRE	72
KTA2500ET32C	KT 3X2500AL FEEDER LENGTH	50	KTA2500FP3D2	KT 3X2500AL FLAT ELBOW N2 FIRE	72
KTA2500ET33D	KT 3X2500AL FEEDER LENGTH	50	KTA2500FP3E1	KT 3X2500AL FLAT ELBOW N1 FIRE	72
KTA2500ET33E	KT 3X2500AL FEEDER LENGTH	50	KTA2500FP3E2	KT 3X2500AL FLAT ELBOW N2 FIRE	72
KTA2500ET33F	KT 3X2500AL FEEDER LENGTH	50	KTA2500FP4A1	KT 4X2500AL FLAT ELBOW N1 FIRE	72
KTA2500ET340	KT 3X2500AL FEEDER LENGTH 4M	50	KTA2500FP4A2	KT 4X2500AL FLAT ELBOW N2 FIRE	72
KTA2500ET41A	KT 4X2500AL FEEDER LENGTH	50	KTA2500FP4B1	KT 4X2500AL FLAT ELBOW N1 FIRE	72
KTA2500ET420	KT 4X2500AL FEEDER LENGTH 2M	50	KTA2500FP4B2	KT 4X2500AL FLAT ELBOW N2 FIRE	72
KTA2500ET42B	KT 4X2500AL FEEDER LENGTH	50	KTA2500FP4D1	KT 4X2500AL FLAT ELBOW N1 FIRE	72
KTA2500ET42C	KT 4X2500AL FEEDER LENGTH	50	KTA2500FP4D2	KT 4X2500AL FLAT ELBOW N2 FIRE	72
KTA2500ET43D	KT 4X2500AL FEEDER LENGTH	50	KTA2500FP4E1	KT 4X2500AL FLAT ELBOW N1 FIRE	72
KTA2500ET43E	KT 4X2500AL FEEDER LENGTH	50	KTA2500FP4E2	KT 4X2500AL FLAT ELBOW N2 FIRE	72
KTA2500ET43F	KT 4X2500AL FEEDER LENGTH	50	KTA2500FP5A1	KT 5X2500AL FLAT ELBOW N1 FIRE	72
KTA2500ET440	KT 4X2500AL FEEDER LENGTH 4M	50	KTA2500FP5A2	KT 5X2500AL FLAT ELBOW N2 FIRE	72
KTA2500ET51A	KT 5X2500AL FEEDER LENGTH	50	KTA2500FP5B1	KT 5X2500AL FLAT ELBOW N1 FIRE	72
KTA2500ET520	KT 5X2500AL FEEDER LENGTH 2M	50	KTA2500FP5B2	KT 5X2500AL FLAT ELBOW N2 FIRE	72
KTA2500ET52B	KT 5X2500AL FEEDER LENGTH	50	KTA2500FP5D1	KT 5X2500AL FLAT ELBOW N1 FIRE	72
KTA2500ET52C	KT 5X2500AL FEEDER LENGTH	50	KTA2500FP5D2	KT 5X2500AL FLAT ELBOW N2 FIRE	72
KTA2500ET53D	KT 5X2500AL FEEDER LENGTH	50	KTA2500FP5E1	KT 5X2500AL FLAT ELBOW N1 FIRE	72
KTA2500ET53E	KT 5X2500AL FEEDER LENGTH	50	KTA2500FP5E2	KT 5X2500AL FLAT ELBOW N2 FIRE	72
KTA2500ET53F	KT 5X2500AL FEEDER LENGTH	50	KTA2500FP6A1	KT 4X2500AL FLAT ELBOW N1 FIRE	72
KTA2500ET540	KT 5X2500AL FEEDER LENGTH 4M	50	KTA2500FP6A2	KT 4X2500AL FLAT ELBOW N2 FIRE	72
KTA2500ET61A	KT 4X2500AL FEEDER LENGTH	50	KTA2500FP6B1	KT 4X2500AL FLAT ELBOW N1 FIRE	72
KTA2500ET620	KT 4X2500AL FEEDER LENGTH 2M	50			
KTA2500ET62B	KT 4X2500AL FEEDER LENGTH	50			
KTA2500ET62C	KT 4X2500AL FEEDER LENGTH	50			
KTA2500ET63D	KT 4X2500AL FEEDER LENGTH	50			

## Index of catalogue numbers

Cat. no.	Designations	Pages	Cat. no.	Designations	Pages
KTA2500FP6B2	KT 4X2500AL FLAT ELBOW N2 FIRE	72	KTA2500LC5D	KT 5X2500AL EDGEWISE ELBOW	61
KTA2500FP6D1	KT 4X2500AL FLAT ELBOW N1 FIRE	72	KTA2500LC5E	KT 5X2500AL EDGEWISE ELBOW	61
KTA2500FP6D2	KT 4X2500AL FLAT ELBOW N2 FIRE	72	KTA2500LC6A	KT 4X2500AL EDGEWISE ELBOW	61
KTA2500FP6E1	KT 4X2500AL FLAT ELBOW N1 FIRE	72	KTA2500LC6B	KT 4X2500AL EDGEWISE ELBOW	61
KTA2500FP6E2	KT 4X2500AL FLAT ELBOW N2 FIRE	72	KTA2500LC6D	KT 4X2500AL EDGEWISE ELBOW	61
KTA2500FP7A1	KT 5X2500AL FLAT ELBOW N1 FIRE	72	KTA2500LC6E	KT 4X2500AL EDGEWISE ELBOW	61
KTA2500FP7A2	KT 5X2500AL FLAT ELBOW N2 FIRE	72	KTA2500LC7A	KT 5X2500AL EDGEWISE ELBOW	61
KTA2500FP7B1	KT 5X2500AL FLAT ELBOW N1 FIRE	72	KTA2500LC7B	KT 5X2500AL EDGEWISE ELBOW	61
KTA2500FP7B2	KT 5X2500AL FLAT ELBOW N2 FIRE	72	KTA2500LC7D	KT 5X2500AL EDGEWISE ELBOW	61
KTA2500FP7D1	KT 5X2500AL FLAT ELBOW N1 FIRE	72	KTA2500LC7E	KT 5X2500AL EDGEWISE ELBOW	61
KTA2500FP7D2	KT 5X2500AL FLAT ELBOW N2 FIRE	72	KTA2500LP3A1	KT 3X2500AL FLAT ELBOW N1	60
KTA2500FP7E1	KT 5X2500AL FLAT ELBOW N1 FIRE	72	KTA2500LP3A2	KT 3X2500AL FLAT ELBOW N2	60
KTA2500FP7E2	KT 5X2500AL FLAT ELBOW N2 FIRE	72	KTA2500LP3B1	KT 3X2500AL FLAT ELBOW N1	60
KTA2500FT31A	KT 3X2500AL FEEDER LENGTH FIRE	70	KTA2500LP3B2	KT 3X2500AL FLAT ELBOW N2	60
KTA2500FT320	KT 3X2500AL FEEDER LENGTH FIRE 2M	70	KTA2500LP3C1	KT 3X2500AL FLAT ELBOW N1	61
KTA2500FT32B	KT 3X2500AL FEEDER LENGTH FIRE	70	KTA2500LP3C2	KT 3X2500AL FLAT ELBOW N2	61
KTA2500FT32C	KT 3X2500AL FEEDER LENGTH FIRE	70	KTA2500LP3D1	KT 3X2500AL FLAT ELBOW N1	60
KTA2500FT33D	KT 3X2500AL FEEDER LENGTH FIRE	70	KTA2500LP3D2	KT 3X2500AL FLAT ELBOW N2	60
KTA2500FT33E	KT 3X2500AL FEEDER LENGTH FIRE	70	KTA2500LP3E1	KT 3X2500AL FLAT ELBOW N1	60
KTA2500FT33F	KT 3X2500AL FEEDER LENGTH FIRE	70	KTA2500LP3E2	KT 3X2500AL FLAT ELBOW N2	60
KTA2500FT340	KT 3X2500AL FEEDER LENGTH FIRE 4M	70	KTA2500LP4A1	KT 4X2500AL FLAT ELBOW N1	60
KTA2500FT41A	KT 4X2500AL FEEDER LENGTH FIRE	70	KTA2500LP4A2	KT 4X2500AL FLAT ELBOW N2	60
KTA2500FT420	KT 4X2500AL FEEDER LENGTH FIRE 2M	70	KTA2500LP4B1	KT 4X2500AL FLAT ELBOW N1	60
KTA2500FT42B	KT 4X2500AL FEEDER LENGTH FIRE	70	KTA2500LP4B2	KT 4X2500AL FLAT ELBOW N2	60
KTA2500FT42C	KT 4X2500AL FEEDER LENGTH FIRE	70	KTA2500LP4C1	KT 4X2500AL FLAT ELBOW N1	61
KTA2500FT43D	KT 4X2500AL FEEDER LENGTH FIRE	70	KTA2500LP4C2	KT 4X2500AL FLAT ELBOW N2	61
KTA2500FT43E	KT 4X2500AL FEEDER LENGTH FIRE	70	KTA2500LP4D1	KT 4X2500AL FLAT ELBOW N1	60
KTA2500FT43F	KT 4X2500AL FEEDER LENGTH FIRE	70	KTA2500LP4D2	KT 4X2500AL FLAT ELBOW N2	60
KTA2500FT440	KT 4X2500AL FEEDER LENGTH FIRE 4M	70	KTA2500LP4E1	KT 4X2500AL FLAT ELBOW N1	60
KTA2500FT51A	KT 5X2500AL FEEDER LENGTH FIRE	70	KTA2500LP4E2	KT 4X2500AL FLAT ELBOW N2	60
KTA2500FT520	KT 5X2500AL FEEDER LENGTH FIRE 2M	70	KTA2500LP5A1	KT 5X2500AL FLAT ELBOW N1	60
KTA2500FT52B	KT 5X2500AL FEEDER LENGTH FIRE	70	KTA2500LP5A2	KT 5X2500AL FLAT ELBOW N2	60
KTA2500FT52C	KT 5X2500AL FEEDER LENGTH FIRE	70	KTA2500LP5B1	KT 5X2500AL FLAT ELBOW N1	60
KTA2500FT53D	KT 5X2500AL FEEDER LENGTH FIRE	70	KTA2500LP5B2	KT 5X2500AL FLAT ELBOW N2	60
KTA2500FT53E	KT 5X2500AL FEEDER LENGTH FIRE	70	KTA2500LP5C1	KT 5X2500AL FLAT ELBOW N1	61
KTA2500FT53F	KT 5X2500AL FEEDER LENGTH FIRE	70	KTA2500LP5C2	KT 5X2500AL FLAT ELBOW N2	61
KTA2500FT540	KT 5X2500AL FEEDER LENGTH FIRE 4M	70	KTA2500LP5D1	KT 5X2500AL FLAT ELBOW N1	60
KTA2500FT61A	KT 4X2500AL FEEDER LENGTH FIRE	70	KTA2500LP5D2	KT 5X2500AL FLAT ELBOW N2	60
KTA2500FT620	KT 4X2500AL FEEDER LENGTH FIRE 2M	70	KTA2500LP5E1	KT 5X2500AL FLAT ELBOW N1	60
KTA2500FT62B	KT 4X2500AL FEEDER LENGTH FIRE	70	KTA2500LP5E2	KT 5X2500AL FLAT ELBOW N2	60
KTA2500FT62C	KT 4X2500AL FEEDER LENGTH FIRE	70	KTA2500LP6A1	KT 4X2500AL FLAT ELBOW N1	60
KTA2500FT63D	KT 4X2500AL FEEDER LENGTH FIRE	70	KTA2500LP6A2	KT 4X2500AL FLAT ELBOW N2	60
KTA2500FT63E	KT 4X2500AL FEEDER LENGTH FIRE	70	KTA2500LP6B1	KT 4X2500AL FLAT ELBOW N1	60
KTA2500FT63F	KT 4X2500AL FEEDER LENGTH FIRE	70	KTA2500LP6B2	KT 4X2500AL FLAT ELBOW N2	60
KTA2500FT640	KT 4X2500AL FEEDER LENGTH FIRE 4M	70	KTA2500LP6C1	KT 4X2500AL FLAT ELBOW N1	61
KTA2500FT71A	KT 5X2500AL FEEDER LENGTH FIRE	70	KTA2500LP6C2	KT 4X2500AL FLAT ELBOW N2	61
KTA2500FT720	KT 5X2500AL FEEDER LENGTH FIRE 2M	70	KTA2500LP6D1	KT 4X2500AL FLAT ELBOW N1	60
KTA2500FT72B	KT 5X2500AL FEEDER LENGTH FIRE	70	KTA2500LP6D2	KT 4X2500AL FLAT ELBOW N2	60
KTA2500FT72C	KT 5X2500AL FEEDER LENGTH FIRE	70	KTA2500LP6E1	KT 4X2500AL FLAT ELBOW N1	60
KTA2500FT73D	KT 5X2500AL FEEDER LENGTH FIRE	70	KTA2500LP6E2	KT 4X2500AL FLAT ELBOW N2	60
KTA2500FT73E	KT 5X2500AL FEEDER LENGTH FIRE	70	KTA2500LP7A1	KT 5X2500AL FLAT ELBOW N1	60
KTA2500FT73F	KT 5X2500AL FEEDER LENGTH FIRE	70	KTA2500LP7A2	KT 5X2500AL FLAT ELBOW N2	60
KTA2500FT740	KT 5X2500AL FEEDER LENGTH FIRE 4M	70	KTA2500LP7B1	KT 5X2500AL FLAT ELBOW N1	60
KTA2500LC3A	KT 3X2500AL EDGEWISE ELBOW	61	KTA2500LP7B2	KT 5X2500AL FLAT ELBOW N2	60
KTA2500LC3B	KT 3X2500AL EDGEWISE ELBOW	61	KTA2500LP7C1	KT 5X2500AL FLAT ELBOW N1	61
KTA2500LC3D	KT 3X2500AL EDGEWISE ELBOW	61	KTA2500LP7C2	KT 5X2500AL FLAT ELBOW N2	61
KTA2500LC3E	KT 3X2500AL EDGEWISE ELBOW	61	KTA2500LP7D1	KT 5X2500AL FLAT ELBOW N1	60
KTA2500LC4A	KT 4X2500AL EDGEWISE ELBOW	61	KTA2500LP7D2	KT 5X2500AL FLAT ELBOW N2	60
KTA2500LC4B	KT 4X2500AL EDGEWISE ELBOW	61	KTA2500LP7E1	KT 5X2500AL FLAT ELBOW N1	60
KTA2500LC4D	KT 4X2500AL EDGEWISE ELBOW	61	KTA2500LP7E2	KT 5X2500AL FLAT ELBOW N2	60
KTA2500LC4E	KT 4X2500AL EDGEWISE ELBOW	61	KTA2500RL61	KT 4X2500AL ISOLATOR UNIT INV VW R	126
KTA2500LC5A	KT 5X2500AL EDGEWISE ELBOW	61	KTA2500RL62	KT 4X2500AL ISOLATOR UNIT INV VW L	126
KTA2500LC5B	KT 5X2500AL EDGEWISE ELBOW	61	KTA2500RL71	KT 5X2500AL ISOLATOR UNIT INV VW R	126

A

B

C

D

E

F

G

## Index of catalogue numbers

Cat. no.	Designations	Pages
<b>KTA2500RL72</b>	KT 5X2500AL ISOLATOR UNIT INV VW L	126
<b>KTA2500SL31</b>	KT 3X2500AL ISOLATOR UNIT INV	125
<b>KTA2500SL41</b>	KT 4X2500AL ISOLATOR UNIT INV	125
<b>KTA2500SL51</b>	KT 5X2500AL ISOLATOR UNIT INV	125
<b>KTA2500TC3</b>	KT 3X2500AL TEE ON EDGE	65
<b>KTA2500TC4</b>	KT 4X2500AL TEE ON EDGE	65
<b>KTA2500TC5</b>	KT 5X2500AL TEE ON EDGE	65
<b>KTA2500TC6</b>	KT 4X2500AL TEE ON EDGE	65
<b>KTA2500TC7</b>	KT 5X2500AL TEE ON EDGE	65
<b>KTA2500TN410</b>	KT 4X2500AL NEUTRAL PERMUTA	56
<b>KTA2500TN610</b>	KT 4X2500AL NEUTRAL PERMUTA	56
<b>KTA2500TP410</b>	KT 4X2500AL PHASES PERMUTA	56
<b>KTA2500TP610</b>	KT 4X2500AL PHASES PERMUTA	56
<b>KTA2500YA3</b>	KT 3X2500AL JUNCTION BLOC	58
<b>KTA2500YA4</b>	KT 4X2500AL JUNCTION BLOC	58
<b>KTA2500YA5</b>	KT 5X2500AL JUNCTION BLOC	58
<b>KTA2500YA6</b>	KT 4X2500AL JUNCTION BLOC	58
<b>KTA2500YA7</b>	KT 5X2500AL JUNCTION BLOC	58
<b>KTA2500ZC31</b>	KT 3X2500AL EDGEWISE ZED N1	66
<b>KTA2500ZC32</b>	KT 3X2500AL EDGEWISE ZED N2	66
<b>KTA2500ZC41</b>	KT 4X2500AL EDGEWISE ZED N1	66
<b>KTA2500ZC42</b>	KT 4X2500AL EDGEWISE ZED N2	66
<b>KTA2500ZC51</b>	KT 5X2500AL EDGEWISE ZED N1	66
<b>KTA2500ZC52</b>	KT 5X2500AL EDGEWISE ZED N2	66
<b>KTA2500ZC61</b>	KT 4X2500AL EDGEWISE ZED N1	66
<b>KTA2500ZC62</b>	KT 4X2500AL EDGEWISE ZED N2	66
<b>KTA2500ZC71</b>	KT 5X2500AL EDGEWISE ZED N1	66
<b>KTA2500ZC72</b>	KT 5X2500AL EDGEWISE ZED N2	66
<b>KTA2500ZP3</b>	KT 3X2500AL ZED ON FLAT	66
<b>KTA2500ZP4</b>	KT 4X2500AL ZED ON FLAT	66
<b>KTA2500ZP5</b>	KT 5X2500AL ZED ON FLAT	66
<b>KTA2500ZP6</b>	KT 5X2500AL ZED ON FLAT	66
<b>KTA2500ZP7</b>	KT 5X2500AL ZED ON FLAT	66

**KTA3200**

<b>KTA3200CP31</b>	KT 3X3200AL FLAT EDGEWISE N1	68
<b>KTA3200CP32</b>	KT 3X3200AL FLAT EDGEWISE N2	68
<b>KTA3200CP33</b>	KT 3X3200AL FLAT EDGEWISE N3	68
<b>KTA3200CP34</b>	KT 3X3200AL FLAT EDGEWISE N4	68
<b>KTA3200CP41</b>	KT 4X3200AL FLAT EDGEWISE N1	68
<b>KTA3200CP42</b>	KT 4X3200AL FLAT EDGEWISE N2	68
<b>KTA3200CP43</b>	KT 4X3200AL FLAT EDGEWISE N3	68
<b>KTA3200CP44</b>	KT 4X3200AL FLAT EDGEWISE N4	68
<b>KTA3200CP51</b>	KT 5X3200AL FLAT EDGEWISE N1	68
<b>KTA3200CP52</b>	KT 5X3200AL FLAT EDGEWISE N2	68
<b>KTA3200CP53</b>	KT 5X3200AL FLAT EDGEWISE N3	68
<b>KTA3200CP54</b>	KT 5X3200AL FLAT EDGEWISE N4	68
<b>KTA3200CP61</b>	KT 4X3200AL FLAT EDGEWISE N1	68
<b>KTA3200CP62</b>	KT 4X3200AL FLAT EDGEWISE N2	68
<b>KTA3200CP63</b>	KT 4X3200AL FLAT EDGEWISE N3	68
<b>KTA3200CP64</b>	KT 4X3200AL FLAT EDGEWISE N4	68
<b>KTA3200CP71</b>	KT 5X3200AL FLAT EDGEWISE N1	68
<b>KTA3200CP72</b>	KT 5X3200AL FLAT EDGEWISE N2	68
<b>KTA3200CP73</b>	KT 5X3200AL FLAT EDGEWISE N3	68
<b>KTA3200CP74</b>	KT 5X3200AL FLAT EDGEWISE N4	68
<b>KTA3200DB310</b>	KT 3X3200AL EXPANSION UNIT	56
<b>KTA3200DB410</b>	KT 4X3200AL EXPANSION UNIT	56
<b>KTA3200DB510</b>	KT 5X3200AL EXPANSION UNIT	56
<b>KTA3200DB610</b>	KT 4X3200AL EXPANSION UNIT	56
<b>KTA3200DB710</b>	KT 5X3200AL EXPANSION UNIT	56
<b>KTA3200EB320</b>	KT 3X3200AL BOLT ON LENGTH 2M	52
<b>KTA3200EB340</b>	KT 3X3200AL BOLT ON LENGTH 4M	52

Cat. no.	Designations	Pages
<b>KTA3200EB420</b>	KT 4X3200AL BOLT ON LENGTH 2M	52
<b>KTA3200EB440</b>	KT 4X3200AL BOLT ON LENGTH 4M	52
<b>KTA3200EB520</b>	KT 5X3200AL BOLT ON LENGTH 2M	52
<b>KTA3200EB540</b>	KT 5X3200AL BOLT ON LENGTH 4M	52
<b>KTA3200EB620</b>	KT 4X3200AL BOLT ON LENGTH 2M	52
<b>KTA3200EB640</b>	KT 4X3200AL BOLT ON LENGTH 4M	52
<b>KTA3200EB720</b>	KT 5X3200AL BOLT ON LENGTH 2M	52
<b>KTA3200EB740</b>	KT 5X3200AL BOLT ON LENGTH 4M	52
<b>KTA3200ED3201</b>	KT 1X3200AL PLUG-IN LENGTH 2M	50
<b>KTA3200ED3203</b>	KT 3X3200AL PLUG-IN LENGTH 2M	50
<b>KTA3200ED3301</b>	KT 1X3200AL PLUG-IN LENGTH	50
<b>KTA3200ED3302</b>	KT 2X3200AL PLUG-IN LENGTH	50
<b>KTA3200ED3351</b>	KT 1X3200AL PLUG-IN LENGTH	50
<b>KTA3200ED3353</b>	KT 3X3200AL PLUG-IN LENGTH	50
<b>KTA3200ED3403</b>	KT 3X3200AL PLUG-IN LENGTH 4M	50
<b>KTA3200ED4201</b>	KT 1X3200AL PLUG-IN LENGTH 2M	50
<b>KTA3200ED4203</b>	KT 4X3200AL PLUG-IN LENGTH 2M	50
<b>KTA3200ED4301</b>	KT 1X3200AL PLUG-IN LENGTH	50
<b>KTA3200ED4302</b>	KT 2X3200AL PLUG-IN LENGTH	50
<b>KTA3200ED4351</b>	KT 1X3200AL PLUG-IN LENGTH	50
<b>KTA3200ED4353</b>	KT 3X3200AL PLUG-IN LENGTH	50
<b>KTA3200ED4403</b>	KT 4X3200AL PLUG-IN LENGTH 4M	50
<b>KTA3200ED5201</b>	KT 1X3200AL PLUG-IN LENGTH 2M	50
<b>KTA3200ED5203</b>	KT 5X3200AL PLUG-IN LENGTH 2M	50
<b>KTA3200ED5301</b>	KT 1X3200AL PLUG-IN LENGTH	50
<b>KTA3200ED5302</b>	KT 2X3200AL PLUG-IN LENGTH	50
<b>KTA3200ED5351</b>	KT 1X3200AL PLUG-IN LENGTH	50
<b>KTA3200ED5353</b>	KT 3X3200AL PLUG-IN LENGTH	50
<b>KTA3200ED5403</b>	KT 5X3200AL PLUG-IN LENGTH 4M	50
<b>KTA3200ED6201</b>	KT 1X3200AL PLUG-IN LENGTH 2M	50
<b>KTA3200ED6203</b>	KT 4X3200AL PLUG-IN LENGTH 2M	50
<b>KTA3200ED6301</b>	KT 1X3200AL PLUG-IN LENGTH	50
<b>KTA3200ED6302</b>	KT 2X3200AL PLUG-IN LENGTH	50
<b>KTA3200ED6351</b>	KT 1X3200AL PLUG-IN LENGTH	50
<b>KTA3200ED6353</b>	KT 3X3200AL PLUG-IN LENGTH	50
<b>KTA3200ED6403</b>	KT 4X3200AL PLUG-IN LENGTH 4M	50
<b>KTA3200ED7201</b>	KT 1X3200AL PLUG-IN LENGTH 2M	50
<b>KTA3200ED7203</b>	KT 5X3200AL PLUG-IN LENGTH 2M	50
<b>KTA3200ED7301</b>	KT 1X3200AL PLUG-IN LENGTH	50
<b>KTA3200ED7302</b>	KT 2X3200AL PLUG-IN LENGTH	50
<b>KTA3200ED7351</b>	KT 1X3200AL PLUG-IN LENGTH	50
<b>KTA3200ED7353</b>	KT 3X3200AL PLUG-IN LENGTH	50
<b>KTA3200ED7403</b>	KT 5X3200AL PLUG-IN LENGTH 4M	50
<b>KTA3200EH320</b>	KT 3X3200AL KH PLUG-IN LENGTH 2M	53
<b>KTA3200EH340</b>	KT 3X3200AL KH PLUG-IN LENGTH 4M	53
<b>KTA3200EH420</b>	KT 4X3200AL KH PLUG-IN LENGTH 2M	53
<b>KTA3200EH440</b>	KT 4X3200AL KH PLUG-IN LENGTH 4M	53
<b>KTA3200EH520</b>	KT 5X3200AL KH PLUG-IN LENGTH 2M	53
<b>KTA3200EH540</b>	KT 5X3200AL KH PLUG-IN LENGTH 4M	53
<b>KTA3200EH620</b>	KT 4X3200AL KH PLUG-IN LENGTH 2M	53
<b>KTA3200EH640</b>	KT 4X3200AL KH PLUG-IN LENGTH 4M	53
<b>KTA3200EH720</b>	KT 5X3200AL KH PLUG-IN LENGTH 2M	53
<b>KTA3200EH740</b>	KT 5X3200AL KH PLUG-IN LENGTH 4M	53
<b>KTA3200EL31</b>	KT 3X3200AL FEED UNIT EL N1	92
<b>KTA3200EL32</b>	KT 3X3200AL FEED UNIT EL N2	92
<b>KTA3200EL33</b>	KT 3X3200AL FEED UNIT EL N3	94
<b>KTA3200EL34</b>	KT 3X3200AL FEED UNIT EL N4	94
<b>KTA3200EL35</b>	KT 3X3200AL FEED UNIT EL N5	95
<b>KTA3200EL41</b>	KT 4X3200AL FEED UNIT EL N1	92
<b>KTA3200EL42</b>	KT 4X3200AL FEED UNIT EL N2	92
<b>KTA3200EL43</b>	KT 4X3200AL FEED UNIT EL N3	94
<b>KTA3200EL44</b>	KT 4X3200AL FEED UNIT EL N4	94
<b>KTA3200EL45</b>	KT 4X3200AL FEED UNIT EL N5	95

## Index of catalogue numbers

Cat. no.	Designations	Pages	Cat. no.	Designations	Pages
KTA3200EL51	KT 5X3200AL FEED UNIT EL N1	92	KTA3200ET43E	KT 4X3200AL FEEDER LENGTH	50
KTA3200EL52	KT 5X3200AL FEED UNIT EL N2	92	KTA3200ET43F	KT 4X3200AL FEEDER LENGTH	50
KTA3200EL53	KT 5X3200AL FEED UNIT EL N3	94	KTA3200ET440	KT 4X3200AL FEEDER LENGTH 4M	50
KTA3200EL54	KT 5X3200AL FEED UNIT EL N4	94	KTA3200ET51A	KT 5X3200AL FEEDER LENGTH	50
KTA3200EL55	KT 5X3200AL FEED UNIT EL N5	95	KTA3200ET520	KT 5X3200AL FEEDER LENGTH 2M	50
KTA3200EL61	KT 4X3200AL FEED UNIT EL N1	92	KTA3200ET52B	KT 5X3200AL FEEDER LENGTH	50
KTA3200EL62	KT 4X3200AL FEED UNIT EL N2	92	KTA3200ET52C	KT 5X3200AL FEEDER LENGTH	50
KTA3200EL63	KT 4X3200AL FEED UNIT EL N3	94	KTA3200ET53D	KT 5X3200AL FEEDER LENGTH	50
KTA3200EL64	KT 4X3200AL FEED UNIT EL N4	94	KTA3200ET53E	KT 5X3200AL FEEDER LENGTH	50
KTA3200EL65	KT 4X3200AL FEED UNIT EL N5	95	KTA3200ET53F	KT 5X3200AL FEEDER LENGTH	50
KTA3200EL71	KT 5X3200AL FEED UNIT EL N1	92	KTA3200ET540	KT 5X3200AL FEEDER LENGTH 4M	50
KTA3200EL72	KT 5X3200AL FEED UNIT EL N2	92	KTA3200ET61A	KT 4X3200AL FEEDER LENGTH	50
KTA3200EL73	KT 5X3200AL FEED UNIT EL N3	94	KTA3200ET620	KT 4X3200AL FEEDER LENGTH 2M	50
KTA3200EL74	KT 5X3200AL FEED UNIT EL N4	94	KTA3200ET62B	KT 4X3200AL FEEDER LENGTH	50
KTA3200EL75	KT 5X3200AL FEED UNIT EL N5	95	KTA3200ET62C	KT 4X3200AL FEEDER LENGTH	50
KTA3200ER31	KT 3X3200AL FEED UNIT ER N1	79	KTA3200ET63D	KT 4X3200AL FEEDER LENGTH	50
KTA3200ER32	KT 3X3200AL FEED UNIT ER N2	79	KTA3200ET63E	KT 4X3200AL FEEDER LENGTH	50
KTA3200ER33	KT 3X3200AL FEED UNIT ER N3	80	KTA3200ET63F	KT 4X3200AL FEEDER LENGTH	50
KTA3200ER34	KT 3X3200AL FEED UNIT ER N4	80	KTA3200ET640	KT 4X3200AL FEEDER LENGTH 4M	50
KTA3200ER35	KT 3X3200AL FEED UNIT ER N5	81	KTA3200ET71A	KT 5X3200AL FEEDER LENGTH	50
KTA3200ER36	KT 3X3200AL FEED UNIT ER N6	81	KTA3200ET720	KT 5X3200AL FEEDER LENGTH 2M	50
KTA3200ER37	KT 3X3200AL FEED UNIT ER N7	85	KTA3200ET72B	KT 5X3200AL FEEDER LENGTH	50
KTA3200ER41	KT 4X3200AL FEED UNIT ER N1	79	KTA3200ET72C	KT 5X3200AL FEEDER LENGTH	50
KTA3200ER42	KT 4X3200AL FEED UNIT ER N2	79	KTA3200ET73D	KT 5X3200AL FEEDER LENGTH	50
KTA3200ER43	KT 4X3200AL FEED UNIT ER N3	80	KTA3200ET73E	KT 5X3200AL FEEDER LENGTH	50
KTA3200ER44	KT 4X3200AL FEED UNIT ER N4	80	KTA3200ET73F	KT 5X3200AL FEEDER LENGTH	50
KTA3200ER45	KT 4X3200AL FEED UNIT ER N5	81	KTA3200ET740	KT 5X3200AL FEEDER LENGTH 4M	50
KTA3200ER46	KT 4X3200AL FEED UNIT ER N6	81	KTA3200FC3A	KT 3X3200AL EDGEWISE ELBOW	73
KTA3200ER47	KT 4X3200AL FEED UNIT ER N7	85	KTA3200FC3B	KT 3X3200AL EDGEWISE ELBOW	73
KTA3200ER51	KT 5X3200AL FEED UNIT ER N1	79	KTA3200FC3D	KT 3X3200AL EDGEWISE ELBOW	73
KTA3200ER52	KT 5X3200AL FEED UNIT ER N2	79	KTA3200FC3E	KT 3X3200AL EDGEWISE ELBOW	73
KTA3200ER53	KT 5X3200AL FEED UNIT ER N3	80	KTA3200FC4A	KT 4X3200AL EDGEWISE ELBOW	73
KTA3200ER54	KT 5X3200AL FEED UNIT ER N4	80	KTA3200FC4B	KT 4X3200AL EDGEWISE ELBOW	73
KTA3200ER55	KT 5X3200AL FEED UNIT ER N5	81	KTA3200FC4D	KT 4X3200AL EDGEWISE ELBOW	73
KTA3200ER56	KT 5X3200AL FEED UNIT ER N6	81	KTA3200FC4E	KT 4X3200AL EDGEWISE ELBOW	73
KTA3200ER57	KT 5X3200AL FEED UNIT ER N7	85	KTA3200FC5A	KT 5X3200AL EDGEWISE ELBOW	73
KTA3200ER61	KT 4X3200AL FEED UNIT ER N1	79	KTA3200FC5B	KT 5X3200AL EDGEWISE ELBOW	73
KTA3200ER62	KT 4X3200AL FEED UNIT ER N2	79	KTA3200FC5D	KT 5X3200AL EDGEWISE ELBOW	73
KTA3200ER63	KT 4X3200AL FEED UNIT ER N3	80	KTA3200FC5E	KT 5X3200AL EDGEWISE ELBOW	73
KTA3200ER64	KT 4X3200AL FEED UNIT ER N4	80	KTA3200FC6A	KT 4X3200AL EDGEWISE ELBOW	73
KTA3200ER65	KT 4X3200AL FEED UNIT ER N5	81	KTA3200FC6B	KT 4X3200AL EDGEWISE ELBOW	73
KTA3200ER66	KT 4X3200AL FEED UNIT ER N6	81	KTA3200FC6D	KT 4X3200AL EDGEWISE ELBOW	73
KTA3200ER67	KT 4X3200AL FEED UNIT ER N7	85	KTA3200FC6E	KT 4X3200AL EDGEWISE ELBOW	73
KTA3200ER71	KT 5X3200AL FEED UNIT ER N1	79	KTA3200FC7A	KT 5X3200AL EDGEWISE ELBOW	73
KTA3200ER72	KT 5X3200AL FEED UNIT ER N2	79	KTA3200FC7B	KT 5X3200AL EDGEWISE ELBOW	73
KTA3200ER73	KT 5X3200AL FEED UNIT ER N3	80	KTA3200FC7D	KT 5X3200AL EDGEWISE ELBOW	73
KTA3200ER74	KT 5X3200AL FEED UNIT ER N4	80	KTA3200FC7E	KT 5X3200AL EDGEWISE ELBOW	73
KTA3200ER75	KT 5X3200AL FEED UNIT ER N5	81	KTA3200FJ3	KT 3X3200AL JUNCTION BLOC FIRE RATED	71
KTA3200ER76	KT 5X3200AL FEED UNIT ER N6	81	KTA3200FJ4	KT 4X3200AL JUNCTION BLOC FIRE RATED	71
KTA3200ER77	KT 5X3200AL FEED UNIT ER N7	85	KTA3200FJ5	KT 5X3200AL JUNCTION BLOC FIRE RATED	71
KTA3200ET31A	KT 3X3200AL FEEDER LENGTH	50	KTA3200FJ6	KT 4X3200AL JUNCTION BLOC FIRE RATED	71
KTA3200ET320	KT 3X3200AL FEEDER LENGTH 2M	50	KTA3200FJ7	KT 5X3200AL JUNCTION BLOC FIRE RATED	71
KTA3200ET32B	KT 3X3200AL FEEDER LENGTH	50	KTA3200FP3A1	KT 3X3200AL FLAT ELBOW N1 FIRE	72
KTA3200ET32C	KT 3X3200AL FEEDER LENGTH	50	KTA3200FP3A2	KT 3X3200AL FLAT ELBOW N2 FIRE	72
KTA3200ET33D	KT 3X3200AL FEEDER LENGTH	50	KTA3200FP3B1	KT 3X3200AL FLAT ELBOW N1 FIRE	72
KTA3200ET33E	KT 3X3200AL FEEDER LENGTH	50	KTA3200FP3B2	KT 3X3200AL FLAT ELBOW N2 FIRE	72
KTA3200ET33F	KT 3X3200AL FEEDER LENGTH	50	KTA3200FP3D1	KT 3X3200AL FLAT ELBOW N1 FIRE	72
KTA3200ET340	KT 3X3200AL FEEDER LENGTH 4M	50	KTA3200FP3D2	KT 3X3200AL FLAT ELBOW N2 FIRE	72
KTA3200ET41A	KT 4X3200AL FEEDER LENGTH	50	KTA3200FP3E1	KT 3X3200AL FLAT ELBOW N1 FIRE	72
KTA3200ET420	KT 4X3200AL FEEDER LENGTH 2M	50	KTA3200FP3E2	KT 3X3200AL FLAT ELBOW N2 FIRE	72
KTA3200ET42B	KT 4X3200AL FEEDER LENGTH	50	KTA3200FP4A1	KT 4X3200AL FLAT ELBOW N1 FIRE	72
KTA3200ET42C	KT 4X3200AL FEEDER LENGTH	50	KTA3200FP4A2	KT 4X3200AL FLAT ELBOW N2 FIRE	72
KTA3200ET43D	KT 4X3200AL FEEDER LENGTH	50	KTA3200FP4B1	KT 4X3200AL FLAT ELBOW N1 FIRE	72

A

B

C

D

E

F

G



## Index of catalogue numbers

Cat. no.	Designations	Pages	Cat. no.	Designations	Pages
KTA3200LP6D2	KT 4X3200AL FLAT ELBOW N2	60	KTA4000CP74	KT 5X4000AL FLAT EDGEWISE N4	68
KTA3200LP6E1	KT 4X3200AL FLAT ELBOW N1	60	KTA4000DB310	KT 3X4000AL EXPANSION UNIT	56
KTA3200LP6E2	KT 4X3200AL FLAT ELBOW N2	60	KTA4000DB410	KT 4X4000AL EXPANSION UNIT	56
KTA3200LP7A1	KT 5X3200AL FLAT ELBOW N1	60	KTA4000DB510	KT 5X4000AL EXPANSION UNIT	56
KTA3200LP7A2	KT 5X3200AL FLAT ELBOW N2	60	KTA4000DB710	KT 5X4000AL EXPANSION UNIT	56
KTA3200LP7B1	KT 5X3200AL FLAT ELBOW N1	60	KTA4000EB320	KT 3X4000AL BOLT ON LENGTH 2M	52
KTA3200LP7B2	KT 5X3200AL FLAT ELBOW N2	60	KTA4000EB340	KT 3X4000AL BOLT ON LENGTH 4M	52
KTA3200LP7C1	KT 5X3200AL FLAT ELBOW N1	61	KTA4000EB420	KT 4X4000AL BOLT ON LENGTH 2M	52
KTA3200LP7C2	KT 5X3200AL FLAT ELBOW N2	61	KTA4000EB440	KT 4X4000AL BOLT ON LENGTH 4M	52
KTA3200LP7D1	KT 5X3200AL FLAT ELBOW N1	60	KTA4000EB520	KT 5X4000AL BOLT ON LENGTH 2M	52
KTA3200LP7D2	KT 5X3200AL FLAT ELBOW N2	60	KTA4000EB540	KT 5X4000AL BOLT ON LENGTH 4M	52
KTA3200LP7E1	KT 5X3200AL FLAT ELBOW N1	60	KTA4000EB720	KT 5X4000AL BOLT ON LENGTH 2M	52
KTA3200LP7E2	KT 5X3200AL FLAT ELBOW N2	60	KTA4000EB740	KT 5X4000AL BOLT ON LENGTH 4M	52
KTA3200SL31	KT 3X3200AL ISOLATOR UNIT NW	127	KTA4000ED3201	KT 1X4000AL PLUG-IN LENGTH 2M	50
KTA3200SL41	KT 4X3200AL ISOLATOR UNIT NW	127	KTA4000ED3203	KT 3X4000AL PLUG-IN LENGTH 2M	50
KTA3200SL51	KT 5X3200AL ISOLATOR UNIT NW	127	KTA4000ED3301	KT 1X4000AL PLUG-IN LENGTH	50
KTA3200SL71	KT 5X3200AL ISOLATOR UNIT NW	127	KTA4000ED3302	KT 2X4000AL PLUG-IN LENGTH	50
KTA3200TC3	KT 3X3200AL TEE ON EDGE	65	KTA4000ED3351	KT 1X4000AL PLUG-IN LENGTH	50
KTA3200TC4	KT 4X3200AL TEE ON EDGE	65	KTA4000ED3353	KT 3X4000AL PLUG-IN LENGTH	50
KTA3200TC5	KT 5X3200AL TEE ON EDGE	65	KTA4000ED3403	KT 3X4000AL PLUG-IN LENGTH 4M	50
KTA3200TC6	KT 4X3200AL TEE ON EDGE	65	KTA4000ED4201	KT 1X4000AL PLUG-IN LENGTH 2M	50
KTA3200TC7	KT 5X3200AL TEE ON EDGE	65	KTA4000ED4203	KT 4X4000AL PLUG-IN LENGTH 2M	50
KTA3200TN410	KT 4X3200AL NEUTRAL PERMUTA	56	KTA4000ED4301	KT 1X4000AL PLUG-IN LENGTH	50
KTA3200TN610	KT 4X3200AL NEUTRAL PERMUTA	56	KTA4000ED4302	KT 2X4000AL PLUG-IN LENGTH	50
KTA3200TP410	KT 4X3200AL PHASES PERMUTA	56	KTA4000ED4351	KT 1X4000AL PLUG-IN LENGTH	50
KTA3200TP610	KT 4X3200AL PHASES PERMUTA	56	KTA4000ED4353	KT 3X4000AL PLUG-IN LENGTH	50
KTA3200YA3	KT 3X3200AL JUNCTION BLOC	58	KTA4000ED4403	KT 4X4000AL PLUG-IN LENGTH 4M	50
KTA3200YA4	KT 4X3200AL JUNCTION BLOC	58	KTA4000ED5201	KT 1X4000AL PLUG-IN LENGTH 2M	50
KTA3200YA5	KT 5X3200AL JUNCTION BLOC	58	KTA4000ED5203	KT 5X4000AL PLUG-IN LENGTH 2M	50
KTA3200YA6	KT 4X3200AL JUNCTION BLOC	58	KTA4000ED5301	KT 1X4000AL PLUG-IN LENGTH	50
KTA3200YA7	KT 5X3200AL JUNCTION BLOC	58	KTA4000ED5302	KT 2X4000AL PLUG-IN LENGTH	50
KTA3200ZC31	KT 3X3200AL EDGEWISE ZED N1	66	KTA4000ED5351	KT 1X4000AL PLUG-IN LENGTH	50
KTA3200ZC32	KT 3X3200AL EDGEWISE ZED N2	66	KTA4000ED5353	KT 3X4000AL PLUG-IN LENGTH	50
KTA3200ZC41	KT 4X3200AL EDGEWISE ZED N1	66	KTA4000ED5403	KT 5X4000AL PLUG-IN LENGTH 4M	50
KTA3200ZC42	KT 4X3200AL EDGEWISE ZED N2	66	KTA4000ED7201	KT 1X4000AL PLUG-IN LENGTH 2M	50
KTA3200ZC51	KT 5X3200AL EDGEWISE ZED N1	66	KTA4000ED7203	KT 5X4000AL PLUG-IN LENGTH 2M	50
KTA3200ZC52	KT 5X3200AL EDGEWISE ZED N2	66	KTA4000ED7301	KT 1X4000AL PLUG-IN LENGTH	50
KTA3200ZC61	KT 4X3200AL EDGEWISE ZED N1	66	KTA4000ED7302	KT 2X4000AL PLUG-IN LENGTH	50
KTA3200ZC62	KT 4X3200AL EDGEWISE ZED N2	66	KTA4000ED7351	KT 1X4000AL PLUG-IN LENGTH	50
KTA3200ZC71	KT 5X3200AL EDGEWISE ZED N1	66	KTA4000ED7353	KT 3X4000AL PLUG-IN LENGTH	50
KTA3200ZC72	KT 5X3200AL EDGEWISE ZED N2	66	KTA4000ED7403	KT 5X4000AL PLUG-IN LENGTH 4M	50
KTA3200ZP3	KT 3X3200AL ZED ON FLAT	66	KTA4000EH320	KT 3X4000AL KH PLUG-IN LENGTH 2M	53
KTA3200ZP4	KT 4X3200AL ZED ON FLAT	66	KTA4000EH340	KT 3X4000AL KH PLUG-IN LENGTH 4M	53
KTA3200ZP5	KT 5X3200AL ZED ON FLAT	66	KTA4000EH420	KT 4X4000AL KH PLUG-IN LENGTH 2M	53
KTA3200ZP6	KT 4X3200AL ZED ON FLAT	66	KTA4000EH440	KT 4X4000AL KH PLUG-IN LENGTH 4M	53
KTA3200ZP7	KT 4X3200AL ZED ON FLAT	66	KTA4000EH520	KT 5X4000AL KH PLUG-IN LENGTH 2M	53
			KTA4000EH540	KT 5X4000AL KH PLUG-IN LENGTH 4M	53
<b>KTA4000</b>			KTA4000EL31	KT 3X4000AL FEED UNIT EL N1	92
KTA4000CP31	KT 3X4000AL FLAT EDGEWISE N1	68	KTA4000EL32	KT 3X4000AL FEED UNIT EL N2	92
KTA4000CP32	KT 3X4000AL FLAT EDGEWISE N2	68	KTA4000EL33	KT 3X4000AL FEED UNIT EL N3	94
KTA4000CP33	KT 3X4000AL FLAT EDGEWISE N3	68	KTA4000EL34	KT 3X4000AL FEED UNIT EL N4	94
KTA4000CP34	KT 3X4000AL FLAT EDGEWISE N4	68	KTA4000EL35	KT 3X4000AL FEED UNIT EL N5	95
KTA4000CP41	KT 4X4000AL FLAT EDGEWISE N1	68	KTA4000EL41	KT 4X4000AL FEED UNIT EL N1	92
KTA4000CP42	KT 4X4000AL FLAT EDGEWISE N2	68	KTA4000EL42	KT 4X4000AL FEED UNIT EL N2	92
KTA4000CP43	KT 4X4000AL FLAT EDGEWISE N3	68	KTA4000EL43	KT 4X4000AL FEED UNIT EL N3	94
KTA4000CP44	KT 4X4000AL FLAT EDGEWISE N4	68	KTA4000EL44	KT 4X4000AL FEED UNIT EL N4	94
KTA4000CP51	KT 5X4000AL FLAT EDGEWISE N1	68	KTA4000EL45	KT 4X4000AL FEED UNIT EL N5	95
KTA4000CP52	KT 5X4000AL FLAT EDGEWISE N2	68	KTA4000EL51	KT 5X4000AL FEED UNIT EL N1	92
KTA4000CP53	KT 5X4000AL FLAT EDGEWISE N3	68	KTA4000EL52	KT 5X4000AL FEED UNIT EL N2	92
KTA4000CP54	KT 5X4000AL FLAT EDGEWISE N4	68	KTA4000EL53	KT 5X4000AL FEED UNIT EL N3	94
KTA4000CP71	KT 5X4000AL FLAT EDGEWISE N1	68	KTA4000EL54	KT 5X4000AL FEED UNIT EL N4	94
KTA4000CP72	KT 5X4000AL FLAT EDGEWISE N2	68	KTA4000EL55	KT 5X4000AL FEED UNIT EL N5	95
KTA4000CP73	KT 5X4000AL FLAT EDGEWISE N3	68	KTA4000EL71	KT 5X4000AL FEED UNIT EL N1	92

## Index of catalogue numbers

Cat. no.	Designations	Pages	Cat. no.	Designations	Pages
<b>KTA4000EL72</b>	KT 5X4000AL FEED UNIT EL N2	92	<b>KTA4000ET740</b>	KT 5X4000AL FEEDER LENGTH 4M	50
<b>KTA4000EL73</b>	KT 5X4000AL FEED UNIT EL N3	94	<b>KTA4000FC3A</b>	KT 3X4000AL EDGEWISE ELBOW	73
<b>KTA4000EL74</b>	KT 5X4000AL FEED UNIT EL N4	94	<b>KTA4000FC3B</b>	KT 3X4000AL EDGEWISE ELBOW	73
<b>KTA4000EL75</b>	KT 5X4000AL FEED UNIT EL N5	95	<b>KTA4000FC3D</b>	KT 3X4000AL EDGEWISE ELBOW	73
<b>KTA4000ER31</b>	KT 3X4000AL FEED UNIT ER N1	79	<b>KTA4000FC3E</b>	KT 3X4000AL EDGEWISE ELBOW	73
<b>KTA4000ER32</b>	KT 3X4000AL FEED UNIT ER N2	79	<b>KTA4000FC4A</b>	KT 4X4000AL EDGEWISE ELBOW	73
<b>KTA4000ER33</b>	KT 3X4000AL FEED UNIT ER N3	80	<b>KTA4000FC4B</b>	KT 4X4000AL EDGEWISE ELBOW	73
<b>KTA4000ER34</b>	KT 3X4000AL FEED UNIT ER N4	80	<b>KTA4000FC4D</b>	KT 4X4000AL EDGEWISE ELBOW	73
<b>KTA4000ER35</b>	KT 3X4000AL FEED UNIT ER N5	81	<b>KTA4000FC4E</b>	KT 4X4000AL EDGEWISE ELBOW	73
<b>KTA4000ER36</b>	KT 3X4000AL FEED UNIT ER N6	81	<b>KTA4000FC5A</b>	KT 5X4000AL EDGEWISE ELBOW	73
<b>KTA4000ER37</b>	KT 3X4000AL FEED UNIT ER N7	85	<b>KTA4000FC5B</b>	KT 5X4000AL EDGEWISE ELBOW	73
<b>KTA4000ER41</b>	KT 4X4000AL FEED UNIT ER N1	79	<b>KTA4000FC5D</b>	KT 5X4000AL EDGEWISE ELBOW	73
<b>KTA4000ER42</b>	KT 4X4000AL FEED UNIT ER N2	79	<b>KTA4000FC5E</b>	KT 5X4000AL EDGEWISE ELBOW	73
<b>KTA4000ER43</b>	KT 4X4000AL FEED UNIT ER N3	80	<b>KTA4000FC7A</b>	KT 5X4000AL EDGEWISE ELBOW	73
<b>KTA4000ER44</b>	KT 4X4000AL FEED UNIT ER N4	80	<b>KTA4000FC7B</b>	KT 5X4000AL EDGEWISE ELBOW	73
<b>KTA4000ER45</b>	KT 4X4000AL FEED UNIT ER N5	81	<b>KTA4000FC7D</b>	KT 5X4000AL EDGEWISE ELBOW	73
<b>KTA4000ER46</b>	KT 4X4000AL FEED UNIT ER N6	81	<b>KTA4000FC7E</b>	KT 5X4000AL EDGEWISE ELBOW	73
<b>KTA4000ER47</b>	KT 4X4000AL FEED UNIT ER N7	85	<b>KTA4000FJ3</b>	KT 3X4000AL JUNCTION BLOC FIRE RATED	71
<b>KTA4000ER51</b>	KT 5X4000AL FEED UNIT ER N1	79	<b>KTA4000FJ4</b>	KT 4X4000AL JUNCTION BLOC FIRE RATED	71
<b>KTA4000ER52</b>	KT 5X4000AL FEED UNIT ER N2	79	<b>KTA4000FJ5</b>	KT 5X4000AL JUNCTION BLOC FIRE RATED	71
<b>KTA4000ER53</b>	KT 5X4000AL FEED UNIT ER N3	80	<b>KTA4000FJ6</b>	KT 4X4000AL JUNCTION BLOC FIRE RATED	71
<b>KTA4000ER54</b>	KT 5X4000AL FEED UNIT ER N4	80	<b>KTA4000FJ7</b>	KT 5X4000AL JUNCTION BLOC FIRE RATED	71
<b>KTA4000ER55</b>	KT 5X4000AL FEED UNIT ER N5	81	<b>KTA4000FP3A1</b>	KT 3X4000AL FLAT ELBOW N1 FIRE	72
<b>KTA4000ER56</b>	KT 5X4000AL FEED UNIT ER N6	81	<b>KTA4000FP3A2</b>	KT 3X4000AL FLAT ELBOW N2 FIRE	72
<b>KTA4000ER57</b>	KT 5X4000AL FEED UNIT ER N7	85	<b>KTA4000FP3B1</b>	KT 3X4000AL FLAT ELBOW N1 FIRE	72
<b>KTA4000ER71</b>	KT 5X4000AL FEED UNIT ER N1	79	<b>KTA4000FP3B2</b>	KT 3X4000AL FLAT ELBOW N2 FIRE	72
<b>KTA4000ER72</b>	KT 5X4000AL FEED UNIT ER N2	79	<b>KTA4000FP3D1</b>	KT 3X4000AL FLAT ELBOW N1 FIRE	72
<b>KTA4000ER73</b>	KT 5X4000AL FEED UNIT ER N3	80	<b>KTA4000FP3D2</b>	KT 3X4000AL FLAT ELBOW N2 FIRE	72
<b>KTA4000ER74</b>	KT 5X4000AL FEED UNIT ER N4	80	<b>KTA4000FP3E1</b>	KT 3X4000AL FLAT ELBOW N1 FIRE	72
<b>KTA4000ER75</b>	KT 5X4000AL FEED UNIT ER N5	81	<b>KTA4000FP3E2</b>	KT 3X4000AL FLAT ELBOW N2 FIRE	72
<b>KTA4000ER76</b>	KT 5X4000AL FEED UNIT ER N6	81	<b>KTA4000FP4A1</b>	KT 4X4000AL FLAT ELBOW N1 FIRE	72
<b>KTA4000ER77</b>	KT 5X4000AL FEED UNIT ER N7	85	<b>KTA4000FP4A2</b>	KT 4X4000AL FLAT ELBOW N2 FIRE	72
<b>KTA4000ET31A</b>	KT 3X4000AL FEEDER LENGTH	50	<b>KTA4000FP4B1</b>	KT 4X4000AL FLAT ELBOW N1 FIRE	72
<b>KTA4000ET320</b>	KT 3X4000AL FEEDER LENGTH 2M	50	<b>KTA4000FP4B2</b>	KT 4X4000AL FLAT ELBOW N2 FIRE	72
<b>KTA4000ET32B</b>	KT 3X4000AL FEEDER LENGTH	50	<b>KTA4000FP4D1</b>	KT 4X4000AL FLAT ELBOW N1 FIRE	72
<b>KTA4000ET32C</b>	KT 3X4000AL FEEDER LENGTH	50	<b>KTA4000FP4D2</b>	KT 4X4000AL FLAT ELBOW N2 FIRE	72
<b>KTA4000ET33D</b>	KT 3X4000AL FEEDER LENGTH	50	<b>KTA4000FP4E1</b>	KT 4X4000AL FLAT ELBOW N1 FIRE	72
<b>KTA4000ET33E</b>	KT 3X4000AL FEEDER LENGTH	50	<b>KTA4000FP4E2</b>	KT 4X4000AL FLAT ELBOW N2 FIRE	72
<b>KTA4000ET33F</b>	KT 3X4000AL FEEDER LENGTH	50	<b>KTA4000FP5A1</b>	KT 5X4000AL FLAT ELBOW N1 FIRE	72
<b>KTA4000ET340</b>	KT 3X4000AL FEEDER LENGTH 4M	50	<b>KTA4000FP5A2</b>	KT 5X4000AL FLAT ELBOW N2 FIRE	72
<b>KTA4000ET41A</b>	KT 4X4000AL FEEDER LENGTH	50	<b>KTA4000FP5B1</b>	KT 5X4000AL FLAT ELBOW N1 FIRE	72
<b>KTA4000ET420</b>	KT 4X4000AL FEEDER LENGTH 2M	50	<b>KTA4000FP5B2</b>	KT 5X4000AL FLAT ELBOW N2 FIRE	72
<b>KTA4000ET42B</b>	KT 4X4000AL FEEDER LENGTH	50	<b>KTA4000FP5D1</b>	KT 5X4000AL FLAT ELBOW N1 FIRE	72
<b>KTA4000ET42C</b>	KT 4X4000AL FEEDER LENGTH	50	<b>KTA4000FP5D2</b>	KT 5X4000AL FLAT ELBOW N2 FIRE	72
<b>KTA4000ET43D</b>	KT 4X4000AL FEEDER LENGTH	50	<b>KTA4000FP5E1</b>	KT 5X4000AL FLAT ELBOW N1 FIRE	72
<b>KTA4000ET43E</b>	KT 4X4000AL FEEDER LENGTH	50	<b>KTA4000FP5E2</b>	KT 5X4000AL FLAT ELBOW N2 FIRE	72
<b>KTA4000ET43F</b>	KT 4X4000AL FEEDER LENGTH	50	<b>KTA4000FP7A1</b>	KT 5X4000AL FLAT ELBOW N1 FIRE	72
<b>KTA4000ET440</b>	KT 4X4000AL FEEDER LENGTH 4M	50	<b>KTA4000FP7A2</b>	KT 5X4000AL FLAT ELBOW N2 FIRE	72
<b>KTA4000ET51A</b>	KT 5X4000AL FEEDER LENGTH	50	<b>KTA4000FP7B1</b>	KT 5X4000AL FLAT ELBOW N1 FIRE	72
<b>KTA4000ET520</b>	KT 5X4000AL FEEDER LENGTH 2M	50	<b>KTA4000FP7B2</b>	KT 5X4000AL FLAT ELBOW N2 FIRE	72
<b>KTA4000ET52B</b>	KT 5X4000AL FEEDER LENGTH	50	<b>KTA4000FP7D1</b>	KT 5X4000AL FLAT ELBOW N1 FIRE	72
<b>KTA4000ET52C</b>	KT 5X4000AL FEEDER LENGTH	50	<b>KTA4000FP7D2</b>	KT 5X4000AL FLAT ELBOW N2 FIRE	72
<b>KTA4000ET53D</b>	KT 5X4000AL FEEDER LENGTH	50	<b>KTA4000FP7E1</b>	KT 5X4000AL FLAT ELBOW N1 FIRE	72
<b>KTA4000ET53E</b>	KT 5X4000AL FEEDER LENGTH	50	<b>KTA4000FP7E2</b>	KT 5X4000AL FLAT ELBOW N2 FIRE	72
<b>KTA4000ET53F</b>	KT 5X4000AL FEEDER LENGTH	50	<b>KTA4000FT31A</b>	KT 3X4000AL FEEDER LENGTH FIRE	70
<b>KTA4000ET540</b>	KT 5X4000AL FEEDER LENGTH 4M	50	<b>KTA4000FT320</b>	KT 3X4000AL FEEDER LENGTH FIRE 2M	70
<b>KTA4000ET71A</b>	KT 5X4000AL FEEDER LENGTH	50	<b>KTA4000FT32B</b>	KT 3X4000AL FEEDER LENGTH FIRE	70
<b>KTA4000ET720</b>	KT 5X4000AL FEEDER LENGTH 2M	50	<b>KTA4000FT32C</b>	KT 3X4000AL FEEDER LENGTH FIRE	70
<b>KTA4000ET72B</b>	KT 5X4000AL FEEDER LENGTH	50	<b>KTA4000FT33D</b>	KT 3X4000AL FEEDER LENGTH FIRE	70
<b>KTA4000ET72C</b>	KT 5X4000AL FEEDER LENGTH	50	<b>KTA4000FT33E</b>	KT 3X4000AL FEEDER LENGTH FIRE	70
<b>KTA4000ET73D</b>	KT 5X4000AL FEEDER LENGTH	50	<b>KTA4000FT33F</b>	KT 3X4000AL FEEDER LENGTH FIRE	70
<b>KTA4000ET73E</b>	KT 5X4000AL FEEDER LENGTH	50	<b>KTA4000FT340</b>	KT 3X4000AL FEEDER LENGTH FIRE 4M	70
<b>KTA4000ET73F</b>	KT 5X4000AL FEEDER LENGTH	50	<b>KTA4000FT41A</b>	KT 4X4000AL FEEDER LENGTH FIRE	70

## Index of catalogue numbers

Cat. no.	Designations	Pages	Cat. no.	Designations	Pages
KTA4000FT420	KT 4X4000AL FEEDER LENGTH FIRE 2M	70	KTA4000LP5C1	KT 5X4000AL FLAT ELBOW N1	61
KTA4000FT42B	KT 4X4000AL FEEDER LENGTH FIRE	70	KTA4000LP5C2	KT 5X4000AL FLAT ELBOW N2	61
KTA4000FT42C	KT 4X4000AL FEEDER LENGTH FIRE	70	KTA4000LP5D1	KT 5X4000AL FLAT ELBOW N1	60
KTA4000FT43D	KT 4X4000AL FEEDER LENGTH FIRE	70	KTA4000LP5D2	KT 5X4000AL FLAT ELBOW N2	60
KTA4000FT43E	KT 4X4000AL FEEDER LENGTH FIRE	70	KTA4000LP5E1	KT 5X4000AL FLAT ELBOW N1	60
KTA4000FT43F	KT 4X4000AL FEEDER LENGTH FIRE	70	KTA4000LP5E2	KT 5X4000AL FLAT ELBOW N2	60
KTA4000FT440	KT 4X4000AL FEEDER LENGTH FIRE 4M	70	KTA4000LP7A1	KT 5X4000AL FLAT ELBOW N1	60
KTA4000FT51A	KT 5X4000AL FEEDER LENGTH FIRE	70	KTA4000LP7A2	KT 5X4000AL FLAT ELBOW N2	60
KTA4000FT520	KT 5X4000AL FEEDER LENGTH FIRE 2M	70	KTA4000LP7B1	KT 5X4000AL FLAT ELBOW N1	60
KTA4000FT52B	KT 5X4000AL FEEDER LENGTH FIRE	70	KTA4000LP7B2	KT 5X4000AL FLAT ELBOW N2	60
KTA4000FT52C	KT 5X4000AL FEEDER LENGTH FIRE	70	KTA4000LP7C1	KT 5X4000AL FLAT ELBOW N1	61
KTA4000FT53D	KT 5X4000AL FEEDER LENGTH FIRE	70	KTA4000LP7C2	KT 5X4000AL FLAT ELBOW N2	61
KTA4000FT53E	KT 5X4000AL FEEDER LENGTH FIRE	70	KTA4000LP7D1	KT 5X4000AL FLAT ELBOW N1	60
KTA4000FT53F	KT 5X4000AL FEEDER LENGTH FIRE	70	KTA4000LP7D2	KT 5X4000AL FLAT ELBOW N2	60
KTA4000FT540	KT 5X4000AL FEEDER LENGTH FIRE 4M	70	KTA4000LP7E1	KT 5X4000AL FLAT ELBOW N1	60
KTA4000FT71A	KT 5X4000AL FEEDER LENGTH FIRE	70	KTA4000LP7E2	KT 5X4000AL FLAT ELBOW N2	60
KTA4000FT720	KT 5X4000AL FEEDER LENGTH FIRE 2M	70	KTA4000TC3	KT 3X4000AL TEE ON EDGE	65
KTA4000FT72B	KT 5X4000AL FEEDER LENGTH FIRE	70	KTA4000TC4	KT 4X4000AL TEE ON EDGE	65
KTA4000FT72C	KT 5X4000AL FEEDER LENGTH FIRE	70	KTA4000TC5	KT 5X4000AL TEE ON EDGE	65
KTA4000FT73D	KT 5X4000AL FEEDER LENGTH FIRE	70	KTA4000TC7	KT 5X4000AL TEE ON EDGE	65
KTA4000FT73E	KT 5X4000AL FEEDER LENGTH FIRE	70	KTA4000TN410	KT 4X4000AL NEUTRAL PERMUTA	56
KTA4000FT73F	KT 5X4000AL FEEDER LENGTH FIRE	70	KTA4000TN610	KT 4X4000AL NEUTRAL PERMUTA	56
KTA4000FT740	KT 5X4000AL FEEDER LENGTH FIRE 4M	70	KTA4000TP410	KT 4X4000AL PHASES PERMUTA	56
KTA4000LC3A	KT 3X4000AL EDGEWISE ELBOW	61	KTA4000TP610	KT 4X4000AL PHASES PERMUTA	56
KTA4000LC3B	KT 3X4000AL EDGEWISE ELBOW	61	KTA4000YA3	KT 3X4000AL JUNCTION BLOC	58
KTA4000LC3D	KT 3X4000AL EDGEWISE ELBOW	61	KTA4000YA4	KT 4X4000AL JUNCTION BLOC	58
KTA4000LC3E	KT 3X4000AL EDGEWISE ELBOW	61	KTA4000YA5	KT 5X4000AL JUNCTION BLOC	58
KTA4000LC4A	KT 4X4000AL EDGEWISE ELBOW	61	KTA4000YA6	KT 4X4000AL JUNCTION BLOC	58
KTA4000LC4B	KT 4X4000AL EDGEWISE ELBOW	61	KTA4000YA7	KT 5X4000AL JUNCTION BLOC	58
KTA4000LC4D	KT 4X4000AL EDGEWISE ELBOW	61	KTA4000ZC31	KT 3X4000AL EDGEWISE ZED N1	66
KTA4000LC4E	KT 4X4000AL EDGEWISE ELBOW	61	KTA4000ZC32	KT 3X4000AL EDGEWISE ZED N2	66
KTA4000LC5A	KT 5X4000AL EDGEWISE ELBOW	61	KTA4000ZC41	KT 4X4000AL EDGEWISE ZED N1	66
KTA4000LC5B	KT 5X4000AL EDGEWISE ELBOW	61	KTA4000ZC42	KT 4X4000AL EDGEWISE ZED N2	66
KTA4000LC5D	KT 5X4000AL EDGEWISE ELBOW	61	KTA4000ZC51	KT 5X4000AL EDGEWISE ZED N1	66
KTA4000LC5E	KT 5X4000AL EDGEWISE ELBOW	61	KTA4000ZC52	KT 5X4000AL EDGEWISE ZED N2	66
KTA4000LC7A	KT 5X4000AL EDGEWISE ELBOW	61	KTA4000ZC71	KT 5X4000AL EDGEWISE ZED N1	66
KTA4000LC7B	KT 5X4000AL EDGEWISE ELBOW	61	KTA4000ZC72	KT 5X4000AL EDGEWISE ZED N2	66
KTA4000LC7D	KT 5X4000AL EDGEWISE ELBOW	61	KTA4000ZP3	KT 3X4000AL ZED ON FLAT	66
KTA4000LC7E	KT 5X4000AL EDGEWISE ELBOW	61	KTA4000ZP4	KT 4X4000AL ZED ON FLAT	66
KTA4000LP3A1	KT 3X4000AL FLAT ELBOW N1	60	KTA4000ZP5	KT 5X4000AL ZED ON FLAT	66
KTA4000LP3A2	KT 3X4000AL FLAT ELBOW N2	60	KTA4000ZP7	KT 5X4000AL ZED ON FLAT	66
KTA4000LP3B1	KT 3X4000AL FLAT ELBOW N1	60			
KTA4000LP3B2	KT 3X4000AL FLAT ELBOW N2	60	<b>KTA5000</b>		
KTA4000LP3C1	KT 3X4000AL FLAT ELBOW N1	61	KTA5000CP31	KT 3X5000AL FLAT EDGEWISE N1	69
KTA4000LP3C2	KT 3X4000AL FLAT ELBOW N2	61	KTA5000CP32	KT 3X5000AL FLAT EDGEWISE N2	69
KTA4000LP3D1	KT 3X4000AL FLAT ELBOW N1	60	KTA5000CP33	KT 3X5000AL FLAT EDGEWISE N3	69
KTA4000LP3D2	KT 3X4000AL FLAT ELBOW N2	60	KTA5000CP34	KT 3X5000AL FLAT EDGEWISE N4	69
KTA4000LP3E1	KT 3X4000AL FLAT ELBOW N1	60	KTA5000CP41	KT 4X5000AL FLAT EDGEWISE N1	69
KTA4000LP3E2	KT 3X4000AL FLAT ELBOW N2	60	KTA5000CP42	KT 4X5000AL FLAT EDGEWISE N2	69
KTA4000LP4A1	KT 4X4000AL FLAT ELBOW N1	60	KTA5000CP43	KT 4X5000AL FLAT EDGEWISE N3	69
KTA4000LP4A2	KT 4X4000AL FLAT ELBOW N2	60	KTA5000CP44	KT 4X5000AL FLAT EDGEWISE N4	69
KTA4000LP4B1	KT 4X4000AL FLAT ELBOW N1	60	KTA5000CP51	KT 5X5000AL FLAT EDGEWISE N1	69
KTA4000LP4B2	KT 4X4000AL FLAT ELBOW N2	60	KTA5000CP52	KT 5X5000AL FLAT EDGEWISE N2	69
KTA4000LP4C1	KT 4X4000AL FLAT ELBOW N1	61	KTA5000CP53	KT 5X5000AL FLAT EDGEWISE N3	69
KTA4000LP4C2	KT 4X4000AL FLAT ELBOW N2	61	KTA5000CP54	KT 5X5000AL FLAT EDGEWISE N4	69
KTA4000LP4D1	KT 4X4000AL FLAT ELBOW N1	60	KTA5000CP71	KT 5X5000AL FLAT EDGEWISE N1	69
KTA4000LP4D2	KT 4X4000AL FLAT ELBOW N2	60	KTA5000CP72	KT 5X5000AL FLAT EDGEWISE N2	69
KTA4000LP4E1	KT 4X4000AL FLAT ELBOW N1	60	KTA5000CP73	KT 5X5000AL FLAT EDGEWISE N3	69
KTA4000LP4E2	KT 4X4000AL FLAT ELBOW N2	60	KTA5000CP74	KT 5X5000AL FLAT EDGEWISE N4	69
KTA4000LP5A1	KT 5X4000AL FLAT ELBOW N1	60	KTA5000DB310	KT 3X5000AL EXPANSION UNIT	57
KTA4000LP5A2	KT 5X4000AL FLAT ELBOW N2	60	KTA5000DB410	KT 4X5000AL EXPANSION UNIT	57
KTA4000LP5B1	KT 5X4000AL FLAT ELBOW N1	60	KTA5000DB510	KT 5X5000AL EXPANSION UNIT	57
KTA4000LP5B2	KT 5X4000AL FLAT ELBOW N2	60	KTA5000DB710	KT 5X5000AL EXPANSION UNIT	57

## Index of catalogue numbers

Cat. no.	Designations	Pages	Cat. no.	Designations	Pages
<b>KTA5000EB320</b>	KT 3X5000AL BOLT ON LENGTH 2M	55	<b>KTA5000ET42C</b>	KT 4X5000AL FEEDER LENGTH	54
<b>KTA5000EB340</b>	KT 3X5000AL BOLT ON LENGTH 4M	55	<b>KTA5000ET43D</b>	KT 4X5000AL FEEDER LENGTH	54
<b>KTA5000EB420</b>	KT 4X5000AL BOLT ON LENGTH 2M	55	<b>KTA5000ET43E</b>	KT 4X5000AL FEEDER LENGTH	54
<b>KTA5000EB440</b>	KT 4X5000AL BOLT ON LENGTH 4M	55	<b>KTA5000ET43F</b>	KT 4X5000AL FEEDER LENGTH	54
<b>KTA5000EB520</b>	KT 5X5000AL BOLT ON LENGTH 2M	55	<b>KTA5000ET440</b>	KT 4X5000AL FEEDER LENGTH 4M	54
<b>KTA5000EB540</b>	KT 5X5000AL BOLT ON LENGTH 4M	55	<b>KTA5000ET51A</b>	KT 5X5000AL FEEDER LENGTH	54
<b>KTA5000EB720</b>	KT 5X5000AL BOLT ON LENGTH 2M	55	<b>KTA5000ET520</b>	KT 5X5000AL FEEDER LENGTH 2M	54
<b>KTA5000EB740</b>	KT 5X5000AL BOLT ON LENGTH 4M	55	<b>KTA5000ET52B</b>	KT 5X5000AL FEEDER LENGTH	54
<b>KTA5000ED3203</b>	KT 3X5000AL PLUG-IN LENGTH 2M	54	<b>KTA5000ET52C</b>	KT 5X5000AL FEEDER LENGTH	54
<b>KTA5000ED3403</b>	KT 3X5000AL PLUG-IN LENGTH 4M	54	<b>KTA5000ET53D</b>	KT 5X5000AL FEEDER LENGTH	54
<b>KTA5000ED4203</b>	KT 4X5000AL PLUG-IN LENGTH 2M	54	<b>KTA5000ET53E</b>	KT 5X5000AL FEEDER LENGTH	54
<b>KTA5000ED4403</b>	KT 4X5000AL PLUG-IN LENGTH 4M	54	<b>KTA5000ET53F</b>	KT 5X5000AL FEEDER LENGTH	54
<b>KTA5000ED5203</b>	KT 5X5000AL PLUG-IN LENGTH 2M	54	<b>KTA5000ET540</b>	KT 5X5000AL FEEDER LENGTH 4M	54
<b>KTA5000ED5403</b>	KT 5X5000AL PLUG-IN LENGTH 4M	54	<b>KTA5000ET71A</b>	KT 5X5000AL FEEDER LENGTH	54
<b>KTA5000ED7203</b>	KT 5X5000AL PLUG-IN LENGTH 2M	54	<b>KTA5000ET720</b>	KT 5X5000AL FEEDER LENGTH 2M	54
<b>KTA5000ED7403</b>	KT 5X5000AL PLUG-IN LENGTH 4M	54	<b>KTA5000ET72B</b>	KT 5X5000AL FEEDER LENGTH	54
<b>KTA5000EL31</b>	KT 3X5000AL FEED UNIT EL N1	93	<b>KTA5000ET72C</b>	KT 5X5000AL FEEDER LENGTH	54
<b>KTA5000EL32</b>	KT 3X5000AL FEED UNIT EL N2	93	<b>KTA5000ET73D</b>	KT 5X5000AL FEEDER LENGTH	54
<b>KTA5000EL35</b>	KT 3X5000AL FEED UNIT EL N5	93	<b>KTA5000ET73E</b>	KT 5X5000AL FEEDER LENGTH	54
<b>KTA5000EL41</b>	KT 4X5000AL FEED UNIT EL N1	93	<b>KTA5000ET73F</b>	KT 5X5000AL FEEDER LENGTH	54
<b>KTA5000EL42</b>	KT 4X5000AL FEED UNIT EL N2	93	<b>KTA5000ET740</b>	KT 5X5000AL FEEDER LENGTH 4M	54
<b>KTA5000EL45</b>	KT 4X5000AL FEED UNIT EL N5	93	<b>KTA5000FC3A</b>	KT 3X5000AL EDGEWISE ELBOW	73
<b>KTA5000EL51</b>	KT 5X5000AL FEED UNIT EL N1	93	<b>KTA5000FC3B</b>	KT 3X5000AL EDGEWISE ELBOW	73
<b>KTA5000EL52</b>	KT 5X5000AL FEED UNIT EL N2	93	<b>KTA5000FC4A</b>	KT 4X5000AL EDGEWISE ELBOW	73
<b>KTA5000EL55</b>	KT 5X5000AL FEED UNIT EL N5	95	<b>KTA5000FC4B</b>	KT 4X5000AL EDGEWISE ELBOW	73
<b>KTA5000EL71</b>	KT 5X5000AL FEED UNIT EL N1	93	<b>KTA5000FC5A</b>	KT 5X5000AL EDGEWISE ELBOW	73
<b>KTA5000EL72</b>	KT 5X5000AL FEED UNIT EL N2	93	<b>KTA5000FC5B</b>	KT 5X5000AL EDGEWISE ELBOW	73
<b>KTA5000EL75</b>	KT 5X5000AL FEED UNIT EL N5	95	<b>KTA5000FC7A</b>	KT 5X5000AL EDGEWISE ELBOW	73
<b>KTA5000ER31</b>	KT 3X5000AL FEED UNIT ER N1	79, 82	<b>KTA5000FC7B</b>	KT 5X5000AL EDGEWISE ELBOW	73
<b>KTA5000ER32</b>	KT 3X5000AL FEED UNIT ER N2	79, 82	<b>KTA5000FJ3</b>	KT 3X5000AL JUNCTION BLOC FIRE RATED	71
<b>KTA5000ER33</b>	KT 3X5000AL FEED UNIT ER N3	83	<b>KTA5000FJ4</b>	KT 4X5000AL JUNCTION BLOC FIRE RATED	71
<b>KTA5000ER34</b>	KT 3X5000AL FEED UNIT ER N4	83	<b>KTA5000FJ5</b>	KT 5X5000AL JUNCTION BLOC FIRE RATED	71
<b>KTA5000ER35</b>	KT 3X5000AL FEED UNIT ER N5	84	<b>KTA5000FJ6</b>	KT 4X5000AL JUNCTION BLOC FIRE RATED	71
<b>KTA5000ER36</b>	KT 3X5000AL FEED UNIT ER N6	84	<b>KTA5000FJ7</b>	KT 5X5000AL JUNCTION BLOC FIRE RATED	71
<b>KTA5000ER41</b>	KT 4X5000AL FEED UNIT ER N1	79, 82	<b>KTA5000FP3A1</b>	KT 3X5000AL FLAT ELBOW N1 FIRE	72
<b>KTA5000ER42</b>	KT 4X5000AL FEED UNIT ER N2	79, 82	<b>KTA5000FP3A2</b>	KT 3X5000AL FLAT ELBOW N2 FIRE	72
<b>KTA5000ER43</b>	KT 4X5000AL FEED UNIT ER N3	83	<b>KTA5000FP3B1</b>	KT 3X5000AL FLAT ELBOW N1 FIRE	72
<b>KTA5000ER44</b>	KT 4X5000AL FEED UNIT ER N4	83	<b>KTA5000FP3B2</b>	KT 3X5000AL FLAT ELBOW N2 FIRE	72
<b>KTA5000ER45</b>	KT 4X5000AL FEED UNIT ER N5	84	<b>KTA5000FP3D1</b>	KT 5X5000AL FLAT ELBOW N1 FIRE	72
<b>KTA5000ER46</b>	KT 4X5000AL FEED UNIT ER N6	84	<b>KTA5000FP3D2</b>	KT 3X5000AL FLAT ELBOW N2 FIRE	72
<b>KTA5000ER51</b>	KT 5X5000AL FEED UNIT ER N1	79, 82	<b>KTA5000FP3E1</b>	KT 5X5000AL FLAT ELBOW N1 FIRE	72
<b>KTA5000ER52</b>	KT 5X5000AL FEED UNIT ER N2	79, 82	<b>KTA5000FP3E2</b>	KT 3X5000AL FLAT ELBOW N2 FIRE	72
<b>KTA5000ER53</b>	KT 5X5000AL FEED UNIT ER N3	83	<b>KTA5000FP4A1</b>	KT 4X5000AL FLAT ELBOW N1 FIRE	72
<b>KTA5000ER54</b>	KT 5X5000AL FEED UNIT ER N4	83	<b>KTA5000FP4A2</b>	KT 4X5000AL FLAT ELBOW N2 FIRE	72
<b>KTA5000ER55</b>	KT 5X5000AL FEED UNIT ER N5	84	<b>KTA5000FP4B1</b>	KT 4X5000AL FLAT ELBOW N1 FIRE	72
<b>KTA5000ER56</b>	KT 5X5000AL FEED UNIT ER N6	84	<b>KTA5000FP4B2</b>	KT 4X5000AL FLAT ELBOW N2 FIRE	72
<b>KTA5000ER71</b>	KT 5X5000AL FEED UNIT ER N1	79, 82	<b>KTA5000FP4D1</b>	KT 5X5000AL FLAT ELBOW N1 FIRE	72
<b>KTA5000ER72</b>	KT 5X5000AL FEED UNIT ER N2	79, 82	<b>KTA5000FP4D2</b>	KT 4X5000AL FLAT ELBOW N2 FIRE	72
<b>KTA5000ER73</b>	KT 5X5000AL FEED UNIT ER N3	83	<b>KTA5000FP4E1</b>	KT 5X5000AL FLAT ELBOW N1 FIRE	72
<b>KTA5000ER74</b>	KT 5X5000AL FEED UNIT ER N4	83	<b>KTA5000FP4E2</b>	KT 4X5000AL FLAT ELBOW N2 FIRE	72
<b>KTA5000ER75</b>	KT 5X5000AL FEED UNIT ER N5	84	<b>KTA5000FP5A1</b>	KT 5X5000AL FLAT ELBOW N1 FIRE	72
<b>KTA5000ER76</b>	KT 5X5000AL FEED UNIT ER N6	84	<b>KTA5000FP5A2</b>	KT 5X5000AL FLAT ELBOW N2 FIRE	72
<b>KTA5000ET31A</b>	KT 3X5000AL FEEDER LENGTH	54	<b>KTA5000FP5B1</b>	KT 5X5000AL FLAT ELBOW N1 FIRE	72
<b>KTA5000ET320</b>	KT 3X5000AL FEEDER LENGTH 2M	54	<b>KTA5000FP5B2</b>	KT 5X5000AL FLAT ELBOW N2 FIRE	72
<b>KTA5000ET32B</b>	KT 3X5000AL FEEDER LENGTH	54	<b>KTA5000FP5D1</b>	KT 5X5000AL FLAT ELBOW N1 FIRE	72
<b>KTA5000ET32C</b>	KT 3X5000AL FEEDER LENGTH	54	<b>KTA5000FP5D2</b>	KT 5X5000AL FLAT ELBOW N2 FIRE	72
<b>KTA5000ET33D</b>	KT 3X5000AL FEEDER LENGTH	54	<b>KTA5000FP5E1</b>	KT 5X5000AL FLAT ELBOW N1 FIRE	72
<b>KTA5000ET33E</b>	KT 3X5000AL FEEDER LENGTH	54	<b>KTA5000FP5E2</b>	KT 5X5000AL FLAT ELBOW N2 FIRE	72
<b>KTA5000ET33F</b>	KT 3X5000AL FEEDER LENGTH	54	<b>KTA5000FP7A1</b>	KT 5X5000AL FLAT ELBOW N1 FIRE	72
<b>KTA5000ET340</b>	KT 3X5000AL FEEDER LENGTH 4M	54	<b>KTA5000FP7A2</b>	KT 5X5000AL FLAT ELBOW N2 FIRE	72
<b>KTA5000ET41A</b>	KT 4X5000AL FEEDER LENGTH	54	<b>KTA5000FP7B1</b>	KT 5X5000AL FLAT ELBOW N1 FIRE	72
<b>KTA5000ET420</b>	KT 4X5000AL FEEDER LENGTH 2M	54	<b>KTA5000FP7B2</b>	KT 5X5000AL FLAT ELBOW N2 FIRE	72
<b>KTA5000ET42B</b>	KT 4X5000AL FEEDER LENGTH	54	<b>KTA5000FP7D1</b>	KT 5X5000AL FLAT ELBOW N1 FIRE	72



## Index of catalogue numbers

Cat. no.	Designations	Pages
<b>KT B0000YE22</b>	KT L PLATE 200 X 2	96
<b>KT B0000YE23</b>	KT L PLATE 200 X 3	96
<b>KT B0000YF1</b>	KT INSULATING SHEATH	103
<b>KT B0000YP11</b>	CANALIS KT CONNECTION PLATE N1	104
<b>KT B0000YP12</b>	CANALIS KT CONNECTION PLATE N2	104
<b>KT B0000YP13</b>	CANALIS KT CONNECTION PLATE N3	104
<b>KT B0000YP14</b>	CANALIS KT CONNECTION PLATE N4	104
<b>KT B0000YP21</b>	KT CONNECTION PLATE HORI ER1 TO ER6	105
<b>KT B0000YP22</b>	KT CONNECTION PLATE VERT ER1 TO ER6	105
<b>KT B0000YS1</b>	KT SUPPORT FOR BARS DBA115	104
<b>KT B0000YS2</b>	KT CLAMP 100	104
<b>KT B0000YS3</b>	KT CLAMP 120	104
<b>KT B0000YT1</b>	KT BRAID 600MM2 L400 8	102
<b>KT B0000ZA1</b>	KT HORI FIXING BRACKED	106
<b>KT B0000ZA3</b>	KT FIXING GRIP	106
<b>KT B0000ZA7</b>	CANALIS KT FLAT WISE SUPPORT 3M	107
<b>KT B0000ZA8</b>	KT FLAT WISE FIXING GRIP	107
<b>KT B0001CR5</b>	KT VERT COVER FEED EL N1 TO N2	99
<b>KT B0001CR6</b>	KT HORI COVER FEED EL N1 TO N2	99
<b>KT B0074CF6</b>	KT FIRE BARRIER KIT H74 L650	109
<b>KT B0074FA</b>	KT END COVER H74	58
<b>KT B0074TT01</b>	KT KT ROOF PLATE H74	78
<b>KT B0074ZA4</b>	KT HORI TOP BRACKED H74	106
<b>KT B0100YC105B</b>	CANALIS KT LINK CU STRAIGHT 100 X MTM	100
<b>KT B0100YC107A</b>	CANALIS KT LINK BI STRAIGHT 100 X MTM	100
<b>KT B0100YC305B</b>	CANALIS KT LINK CU WAVY 100 X MTM	100
<b>KT B0100YC307A</b>	CANALIS KT LINK BI WAVY 100 X MTM	100
<b>KT B0100YC50506B</b>	CANALIS KT LINK CU INSULATED 100 X 600	101
<b>KT B0100YC50510B</b>	CANALIS KT LINK CU INSULATED 100 X 1000	101
<b>KT B0100YC50706A</b>	CANALIS KT LINK BI INSULATED 100 X 600	101
<b>KT B0100YC50710A</b>	CANALIS KT LINK BI INSULATED 100 X 1000	101
<b>KT B0104CF6</b>	KT FIRE BARRIER KIT H104 L650	109
<b>KT B0104FA</b>	KT END COVER H104	58
<b>KT B0104TT01</b>	KT KT ROOF PLATE H104	78
<b>KT B0120YC105B</b>	CANALIS KT LINK CU STRAIGHT 120 X MTM	100
<b>KT B0120YC107A</b>	CANALIS KT LINK BI STRAIGHT 120 X MTM	100
<b>KT B0120YC305B</b>	CANALIS KT LINK CU WAVY 120 X MTM	100
<b>KT B0120YC307A</b>	CANALIS KT LINK BI WAVY 120 X MTM	100
<b>KT B0124CF6</b>	KT FIRE BARRIER KIT H124 L650	109
<b>KT B0124FA</b>	KT END COVER H124	58
<b>KT B0124TT01</b>	KT KT ROOF PLATE H124	78
<b>KT B0124ZA7</b>	CANALIS KT FLAT WISE SUPPORT H124	107
<b>KT B0164CF6</b>	KT FIRE BARRIER KIT H164 L650	109
<b>KT B0164FA</b>	KT END COVER H164	58
<b>KT B0164PE1</b>	KT END COVER H164	74, 75, 77, 78
<b>KT B0164TT01</b>	KT KT ROOF PLATE H164	78
<b>KT B0164ZA51</b>	CANALIS KT VERTICAL SUPPORT H74A164	108
<b>KT B0164ZA52</b>	CANALIS KT WALL BRACKET H74A164	108
<b>KT B0204CF6</b>	KT FIRE BARRIER KIT H204 L650	109
<b>KT B0204FA</b>	KT END COVER H204	58
<b>KT B0204TT01</b>	KT KT ROOF PLATE H204	78
<b>KT B0204ZA51</b>	CANALIS KT VERTICAL SUPPORT H204	108
<b>KT B0204ZA52</b>	CANALIS KT WALL BRACKET H204	108
<b>KT B0204ZA7</b>	CANALIS KT FLAT WISE SUPPORT H204	107
<b>KT B0230BC01</b>	KT CABLES BOX Y230	90
<b>KT B0230CR1</b>	KT HORI COVER FEED ER Y230	86
<b>KT B0230CR2</b>	KT HIGH VERT COVER FEED Y230	87
<b>KT B0230CR3</b>	KT LOW VERT COVER FEED Y230	87
<b>KT B0230CR6</b>	KT HORI COVER FEED EL N5 Y230	98
<b>KT B0230CR71</b>	CANALIS KT HORI COVER FOR OIL TR Y230 N1	88
<b>KT B0230CR81</b>	CANALIS KT VERT COVER FOR OIL TR Y230 N1	89

Cat. no.	Designations	Pages
<b>KT B0230CS0</b>	KT FLEXIBLE COVER Y230 E115	90
<b>KT B0244CF6</b>	KT FIRE BARRIER KIT H244 L650	109
<b>KT B0244FA</b>	KT END COVER H244	58
<b>KT B0244PE1</b>	KT END COVER H244	74, 77, 78
<b>KT B0244TT01</b>	KT KT ROOF PLATE H244	78
<b>KT B0244ZA51</b>	CANALIS KT VERTICAL SUPPORT H244	108
<b>KT B0244ZA52</b>	CANALIS KT WALL BRACKET H244	108
<b>KT B0244ZA7</b>	CANALIS KT FLAT WISE SUPPORT H244	107
<b>KT B0324CF6</b>	KT FIRE BARRIER KIT H324 L650	109
<b>KT B0324FA</b>	KT END COVER H324	58
<b>KT B0324TT01</b>	KT KT ROOF PLATE H324	78
<b>KT B0324ZA51</b>	CANALIS KT VERTICAL SUPPORT H324	108
<b>KT B0324ZA52</b>	CANALIS KT WALL BRACKET H324	108
<b>KT B0324ZA7</b>	CANALIS KT FLAT WISE SUPPORT H324	107
<b>KT B0350BC01</b>	KT CABLES BOX Y350	90
<b>KT B0350CR1</b>	KT HORI COVER FEED ER Y350	86
<b>KT B0350CR2</b>	KT HIGH VERT COVER FEED Y350	87
<b>KT B0350CR3</b>	KT LOW VERT COVER FEED Y350	87
<b>KT B0350CR6</b>	KT HORI COVER FEED EL N5 Y350	98
<b>KT B0350CR71</b>	CANALIS KT HORI COVER FOR OIL TR Y350 N1	88
<b>KT B0350CR72</b>	CANALIS KT HORI COVER FOR OIL TR Y350 N2	88
<b>KT B0350CR73</b>	CANALIS KT HORI COVER FOR OIL TR Y350 N3	88
<b>KT B0350CR74</b>	CANALIS KT HORI COVER FOR OIL TR Y350 N4	88
<b>KT B0350CR81</b>	CANALIS KT VERT COVER FOR OIL TR Y350 N1	89
<b>KT B0350CR82</b>	CANALIS KT VERT COVER FOR OIL TR Y350 N2	89
<b>KT B0350CR83</b>	CANALIS KT VERT COVER FOR OIL TR Y350 N3	89
<b>KT B0350CS0</b>	KT FLEXIBLE COVER Y350 E115	90
<b>KT B0350HT01</b>	KT CONNECTION KHF KGF Y350 N1	131
<b>KT B0350HT02</b>	KT CONNECTION KHF KGF Y350 N2	131
<b>KT B0350HT12</b>	KT CONNECTION KHF27/29 Y350	131
<b>KT B0404CF6</b>	KT FIRE BARRIER KIT H404 L650	109
<b>KT B0404FA</b>	KT END COVER H404	58
<b>KT B0404PE1</b>	KT END COVER H404	74, 77, 78
<b>KT B0404TT01</b>	KT KT ROOF PLATE H404	78
<b>KT B0404ZA4</b>	KT HORI TOP BRACKED H104 A 404	106
<b>KT B0404ZA51</b>	CANALIS KT VERTICAL SUPPORT H404	108
<b>KT B0404ZA52</b>	CANALIS KT WALL BRACKET H404	108
<b>KT B0404ZA7</b>	CANALIS KT FLAT WISE SUPPORT H404	107
<b>KT B04703</b>	CANALIS INTERFACE, 1600 A, 3P	75
<b>KT B04704</b>	CANALIS INTERFACE, 1600 A, 4P	75
<b>KT B04715</b>	CANALIS CONNECTION, 1600 A, NW, 3P	74
<b>KT B04716</b>	CANALIS CONNECTION, 1600 A, NW, 4P	74
<b>KT B04725</b>	CANALIS CONNECTION, 2500 A, NW, 3P	74
<b>KT B04726</b>	CANALIS CONNECTION, 2500 A, NW, 4P	74
<b>KT B04735</b>	CANALIS CONNECTION, 3200 A, NW, 3P	74
<b>KT B04736</b>	CANALIS CONNECTION, 3200 A, NW, 4P	74
<b>KT B04737</b>	CANALIS CONNECTION, 4000 A, NW, 3P	74
<b>KT B04738</b>	CANALIS CONNECTION, 4000 A, NW, 4P	74
<b>KT B0510BC01</b>	KT CABLES BOX Y510	90
<b>KT B0510CR1</b>	KT HORI COVER FEED ER Y510	86
<b>KT B0510CR2</b>	KT HIGH VERT COVER FEED Y510	87
<b>KT B0510CR3</b>	KT LOW VERT COVER FEED Y510	87
<b>KT B0510CR6</b>	KT HORI COVER FEED EL N5 Y510	98
<b>KT B0510CR71</b>	CANALIS KT HORI COVER FOR OIL TR Y510 N1	88
<b>KT B0510CR72</b>	CANALIS KT HORI COVER FOR OIL TR Y510 N2	88
<b>KT B0510CR73</b>	CANALIS KT HORI COVER FOR OIL TR Y510 N3	88

## Index of catalogue numbers

Cat. no.	Designations	Pages	Cat. no.	Designations	Pages
<b>KTB0510CR81</b>	CANALIS KT VERT COVER FOR OIL TR Y510 N1	89	<b>KTB87816</b>	DBA 115 CONNECTING BLOCK FOR KT BBT 3200A 4P TDC	77
<b>KTB0510CR82</b>	CANALIS KT VERT COVER FOR OIL TR Y510 N2	89	<b>KTB87817</b>	DBA 115 CONNECTING BLOCK FOR KT BBT 4000A 3P TDC	77
<b>KTB0510CS0</b>	KT FLEXIBLE COVER Y510 E115	90	<b>KTB87818</b>	DBA 115 CONNECTING BLOCK FOR KT BBT 4000A 4P TDC	77
<b>KTB0510HT01</b>	KT CONNECTION KHF KGF Y510 N1	131	<b>KTB87821</b>	DBA 115 CONNECTING BLOCK FOR KT BBT 800/1600A 3P RC	77
<b>KTB0510HT02</b>	KT CONNECTION KHF KGF Y510 N2	131	<b>KTB87822</b>	DBA 115 CONNECTING BLOCK FOR KT BBT 800/1600A 4P RC	77
<b>KTB0510HT03</b>	KT CONNECTION KHF KGF Y510 N3	131	<b>KTB87823</b>	DBA 115 CONNECTING BLOCK FOR KT BBT 2000/2500A 3P RC	77
<b>KTB0510HT11</b>	KT CONNECTION KHF37/39 Y510	131	<b>KTB87824</b>	DBA 115 CONNECTING BLOCK FOR KT BBT 2000/2500A 4P RC	77
<b>KTB0622CF6</b>	KT FIRE BARRIER KIT H622 L750	109	<b>KTB87825</b>	DBA 115 CONNECTING BLOCK FOR KT BBT 3200A 3P RC	77
<b>KTB0622FA</b>	KT END COVER H622	58	<b>KTB87826</b>	DBA 115 CONNECTING BLOCK FOR KT BBT 3200A 4P RC	77
<b>KTB0622PE1</b>	KT REINFORCED PROTECTIVE EARTH H622	74, 77, 78	<b>KTB87827</b>	DBA 115 CONNECTING BLOCK FOR KT BBT 4000A 3P RC	77
<b>KTB0622TT01</b>	KT KT ROOF PLATE H622	78	<b>KTB87828</b>	DBA 115 CONNECTING BLOCK FOR KT BBT 4000A 4P RC	77
<b>KTB0622ZA7</b>	CANALIS KT FLAT WISE SUPPORT H622	107			
<b>KTB0630CB3</b>	KT FIXED TAP-OFF 3L PE NS630	123	<b>LVS</b>		
<b>KTB0630CB4</b>	KT FIXED TAP-OFF 3L N PE NS630	123	<b>LVS03561</b>	CANALIS SUPPORT	76
<b>KTB0630CB5</b>	KT FIXED TAP-OFF 3L PEN NS630	123	<b>LVS04694</b>	CONNECTION SUPPORT, 115 MM BETWEEN CENTRES	76
<b>KTB0630DC4</b>	KT PLUGIN 630A NSX 3L N	114	<b>LVS04711</b>	CANALIS CONNECTION FOR FRONT-CONNECTED NS-NT, 3P	76
<b>KTB0630DC5</b>	KT PLUGIN 630A NSX 3L PEN	114	<b>LVS04712</b>	CANALIS CONNECTION FOR FRONT-CONNECTED NS-NT, 4P	76
<b>KTB0630HF3</b>	KT COFF 3L PE FUS SWITCH 630	124	<b>LVS04713</b>	CANALIS CONNECTION FOR REAR-CONNECTED NS-NT, 3P	76
<b>KTB0630HF4</b>	KT COFF 3L N PE FUS SWITCH 630	124	<b>LVS04714</b>	CANALIS CONNECTION FOR REAR-CONNECTED NS-NT, 4P	76
<b>KTB0630HF5</b>	KT COFF 3L PEN FUS SWITCH 630	124	<b>LVS04739</b>	CANALIS SUPPORT FOR MTZ3/NW40B-63	76
<b>KTB0630SD4</b>	KT PLUGIN 630A FUS 3LN	119	<b>LVS04851</b>	FRONT CONNECTION COVER FOR VERTICAL FIXED NS1600	76
<b>KTB0630SD5</b>	KT PLUGIN 630A FUS 3LPEN	119	<b>LVS04852</b>	FRONT CONNECTION COVER FOR VERTICAL FIXED NS1600-NT	76
<b>KTB0630SE4L</b>	KT PLUGIN 630A FUS 3LN ADV L	120	<b>LVS04853</b>	REAR CONNECTION COVER FOR VERTICAL FIXED NS1600	76
<b>KTB0630SE4R</b>	KT PLUGIN 630A FUS 3LN ADV R	120	<b>LVS04854</b>	REAR CONNECTION COVER FOR VERTICAL FIXED NS1600-NT	76
<b>KTB0630SE5L</b>	KT PLUGIN 630A FUS 3LPEN ADV L	120	<b>LVS04861</b>	FRONT CONNECTION COVER FOR NW	76
<b>KTB0630SE5R</b>	KT PLUGIN 630A FUS 3LPEN ADV R	120	<b>LVS04863</b>	REAR CONNECTION COVER FOR NW	76
<b>KTB0630ZA01</b>	KT CONNECTION BARS KIT 630 NSX	114	<b>LVS04871</b>	CANALIS COVER	76
<b>KTB0630ZA02</b>	KT CONNECTION BARS KIT 630 FUSE	119	<b>LVS08903</b>	12 ADHESIVE LABEL HOLDERS, H=24 MM, W=432 MM	122
<b>KTB0630ZA03</b>	KT ROTARY HANDLE FOR FUSES	119, 120, 137	<b>LVS08905</b>	12 ADHESIVE LABEL HOLDERS, H=24 MM, W=180 MM	122
<b>KTB0630ZA04</b>	KT CONNECTING BOX	114, 119, 120, 136, 137	<b>LVS08907</b>	12 ADHESIVE LABEL HOLDERS, H=24 MM, W=650 MM	122
<b>KTB0726CR1</b>	KT HORI COVER FEED ER Y726	86			
<b>KTB0726CR3</b>	KT LOW VERT COVER FEED Y726	87			
<b>KTB0726CR71</b>	KT HORI COVER FEED ER Y726	88			
<b>KTB0726CR81</b>	KT LOW VERT COVER FEED Y726	89			
<b>KTB1000CB3</b>	KT FIXED TAP-OFF 3L PE NS1000	123			
<b>KTB1000CB4</b>	KT FIXED TAP-OFF 3L N PE NS1000	123			
<b>KTB1000CB5</b>	KT FIXED TAP-OFF 3L PEN NS1000	123			
<b>KTB1000HF3</b>	KT COFF 3L PE FUS SWITCH 1000	124			
<b>KTB1000HF4</b>	KT COFF 3L N PE FUS SWITCH 1000	124			
<b>KTB1000HF5</b>	KT COFF 3L PEN FUS SWITCH 1000	124			
<b>KTB1203</b>	DBA 230 CONNECTING BLOCK FOR KT BBT 5000 A 3P RC CANALIS	77			
<b>KTB1204</b>	DBA 230 CONNECTING BLOCK FOR KT BBT 5000 A 4P RC CANALIS	77			
<b>KTB1207</b>	DBA 230 CONNECTING BLOCK FOR KT BBT 6300 A 3P RC CANALIS	74, 77			
<b>KTB1208</b>	DBA 230 CONNECTING BLOCK FOR KT BBT 6300 A 4P RC CANALIS	74, 77			
<b>KTB1250CB3</b>	KT COFF BOULO 3L PE NS 1250	123			
<b>KTB1250CB4</b>	KT COFF BOULO 3L N PE NS 1250	123			
<b>KTB1250CB5</b>	KT COFF BOULO 3L PEN NS 1250	123			
<b>KTB87811</b>	DBA 115 CONNECTING BLOCK FOR KT BBT 800/1600A 3P TDC	77			
<b>KTB87812</b>	DBA 115 CONNECTING BLOCK FOR KT BBT 800/1600A 4P TDC	77			
<b>KTB87813</b>	DBA 115 CONNECTING BLOCK FOR KT BBT 2000/2500A 3P TDC	77			
<b>KTB87814</b>	DBA 115 CONNECTING BLOCK FOR KT BBT 2000/2500A 4P TDC	77			
<b>KTB87815</b>	DBA 115 CONNECTING BLOCK FOR KT BBT 3200A 3P TDC	77			

A

B

C

D

E

F

G







[Learn more about Canalis KT online](#)

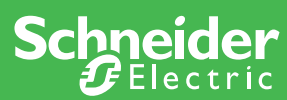

**Schneider Electric Industries SAS**

35, rue Joseph Monier  
CS 30323  
92506 Rueil Malmaison Cedex  
France

RCS Nanterre 954 503 439  
Capital social 896 313 776 €  
[www.se.com](http://www.se.com)

04-2026  
DEBU021EN

© 2026 - Schneider Electric. All Rights Reserved.  
All trademarks are owned by Schneider Electric Industries SAS or its affiliated companies.