

# Wilco

# CLIPSAL®

by Schneider Electric

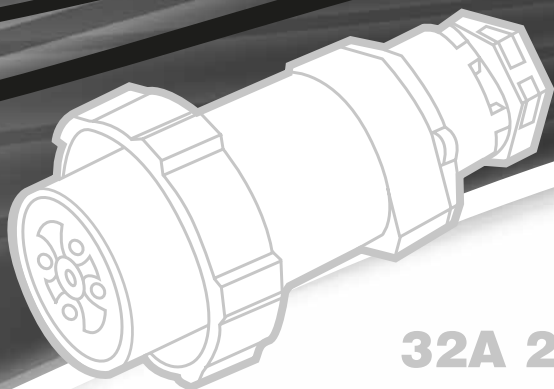

## WIPXXXRB Series 32A 250V/500V Models Installation Instructions

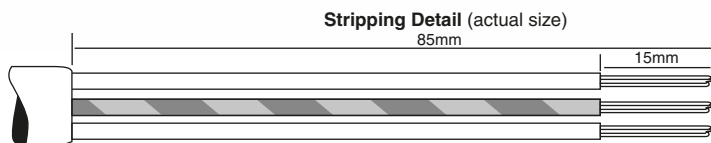
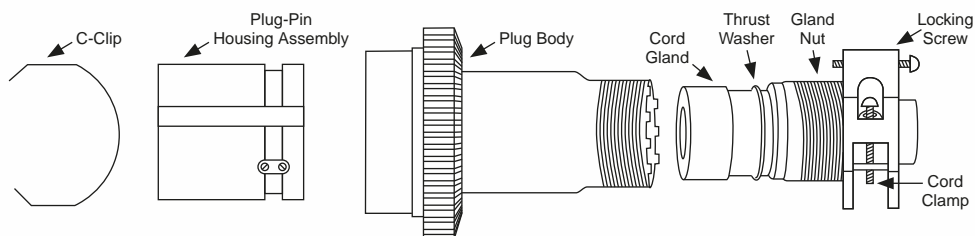

### Instructions

1. Unscrew gland nut with complete gland assembly intact. Loosen cord clamp.
2. Depending on flexible cord size, remove the required internal segments of the cord gland to achieve a close fit around the outside diameter of the flexible cord. This is important to maintain the IP rating.
3. Place hand over pin surround. Lever out c-clip, being careful not to lose spring clip.

## Instructions continued

4. Remove plug-pin housing assembly from plug body.
5. Strip flexible cord as shown, pass through gland nut, cable gland and plug body.
6. Place appropriate conductors into plug-pin housing assembly terminals and tighten screws to secure bare conductors and ensure good electrical contact. Check Earth is connected to E terminal.
7. Pull excess cord in plug cover until pin housing assembly seats itself in cover. Re-insert c-clip spring.
8. Screw gland nut tight to ensure IP rating is maintained.
9. To lock gland nut in place, terminate locking screw into recess provided.
10. Tighten clamp onto cord.

This product is designed to effectively clamp and seal on cable outside diameters as listed. Other devices such as cable glands, flexible conduit adaptors, etc. may be used but they will need to have the thread form (as shown below) to suit the product.

Cat. No.	Description	Max Cable O.D. (mm)	Min Cable I.D. (mm)	Alt. Entry Thread Form (mm)
WIP132RB	3 Pin 32A, 250V	21.5	14.5	M40 x 1.5
WIP432RB	4 Pin 32A, 500V	21.5	14.5	M40 x 1.5
WIP532RB	5 Pin 32A, 500V	21.5	14.5	M40 x 1.5

Schneider Electric (Australia) Pty Ltd

[clipsal.com](http://clipsal.com)

Contact us: [clipsal.com/feedback](http://clipsal.com/feedback)

National Customer Care Enquiries:

**Tel 1300 2025 25**

**Fax 1300 2025 56**

Schneider Electric (Australia) Pty Ltd reserves the right to change specifications, modify designs and discontinue items without incurring obligation and whilst every effort is made to ensure that descriptions, specifications and other information in this catalogue are correct, no warranty is given in respect thereof and the company shall not be liable for any error therein.

© 2011 Schneider Electric. All Rights Reserved.  
Trademarks are owned by Schneider Electric Industries SAS or its affiliated companies.