



# CLIPSAL®

by Schneider Electric

## Clipper Light for Ceiling Fan Models:

ACES36\*\*, ACES36J\*\*, ACES48\*\*, ACES48J\*\*, ACES56\*\*, ACES56J\*\*, 4HS1200\*\*, 4HS1400\*\*.

# Light Kit Installation Instructions

## Clipper Light Kit

There are a large variety of lamp dimensions on the market. The following instructions are structured to ensure correct lamp orientation and minimise the potential for rattles and noises. The following job must be completed by a qualified electrician.

**Note:** Ensure power is OFF or DISCONNECTED when installing or replacing lamps.

### STEP 1:

Unscrew the plastic nipple from the bottom of the motor housing. Pull out the light wires from the motor housing for connection with the light kit.

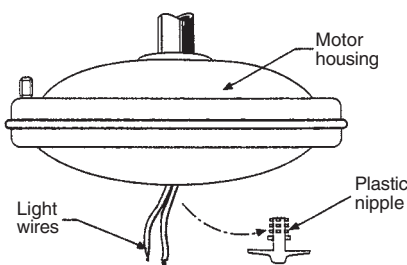

### STEP 2:

Insert the light wires with sleeving through the adaptor and screw the adaptor into the motor shaft.

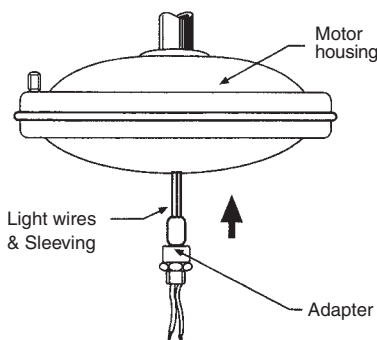

### STEP 3:

Secure the light kit and the motor together by tightening firmly the star washer and the hexagonal nut provided.

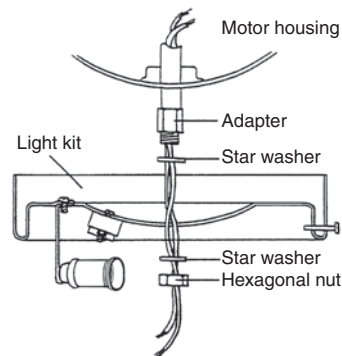

### STEP 4:

Thread the wires through the fibreglass sleeve provided.

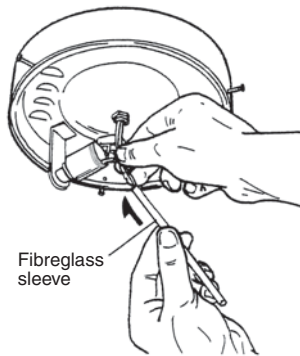

### STEP 5:

Connect the wires to the terminal block.

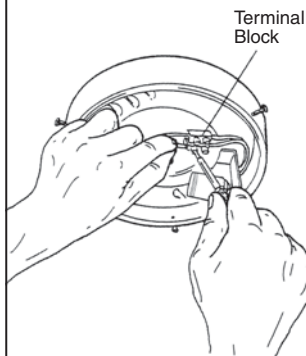

### STEP 6:

Secure a light bulb into the lampholder. CAUTION: Max. 60W (incandescent) / max. 15W (CFL).

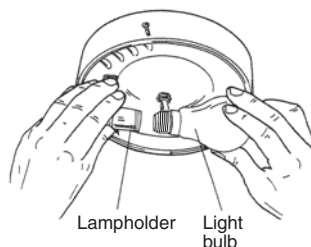

### STEP 7:

Assemble the glass shade onto the light kit by tightening the three thumb screws. CAUTION: Do not use pliers to tighten the thumb screws. Overtightening of the thumb screws may crack the glass shade.

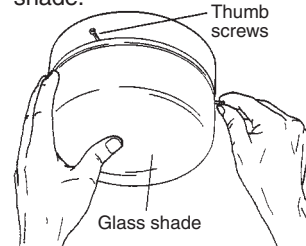

Clipsal Australia Pty Ltd

A member of Schneider Electric

Contact us: [clipsal.com/feedback](http://clipsal.com/feedback)

National Customer Care Enquiries:

Tel 1300 2025 25 Fax 1300 2025 56

[clipsal.com](http://clipsal.com)

Clipsal Australia Pty Ltd reserves the right to change specifications, modify designs and discontinue items without incurring obligation and whilst every effort is made to ensure that descriptions, specifications and other information in this catalogue are correct, no warranty is given in respect thereof and the company shall not be liable for any error therein.

© Clipsal Australia Pty Ltd. The identified trademarks and copyrights are the property of Clipsal Australia Pty Ltd unless otherwise noted.