



THROUGH-WALL KIT

Models 6412, 6512, 6612

INSTALLATION INSTRUCTIONS

INSTALL AS FOLLOWS:

1. Follow Wall/Ceiling Exhaust fan installation instructions.
2. Remove all parts from the packaging.
3. Locate an external (outdoor side) wall or soffit to place the grille surround ensuring that the area is free from obstruction and is between two joists.
4. Place aluminium ducting on location chosen and draw an outline around the duct. Alternatively, use this card as a template for marking appropriate hole size.
5. Cut out the outline using a suitable tool.
6. Feed the aluminium ducting through the hole and secure to the fan unit motor housing (which has to be detached from wall or ceiling). Re-attach fan unit to wall or ceiling.
7. Pull the aluminium ducting gently to meet the outlet end of the grille surround.
8. Cut the ducting to length and secure to the outlet of the grille surround using a suitable means of clamping.
9. Carefully remove angled fixed grille from the centre of grille surround using a suitable tool.
10. Fix grille surround to the chosen location using the screws and wall plugs provided or by other suitable means and seal if required.
11. Replace angled fixed grille 'A' or alternatively fit gravity louvres 'B' (wall mounting only) onto the grille surround.

NOTES:

1. Make sure wherever possible that the flexible ducting is kept straight and as taut as possible, maintaining wherever possible swept along radius bends, as this will improve the performance of the unit.
2. PDL Industries Ltd does not bear any responsibility if Model 6412, 6512 or 6612 Through Wall Kits are fitted to another manufacturers fan in reference to performance or its warranty.
3. Precautions must be taken to avoid the back-flow of gases into the room from the open flue of gas or other open-fire appliances.

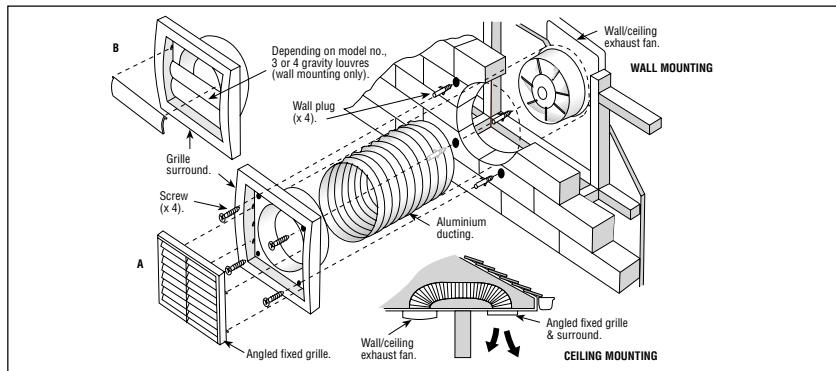

THROUGH-WALL-KIT-PDL-080703-L



This product is guaranteed for a period of two years from the date of purchase against defects in workmanship and materials (excluding broken elements in radiant heaters and lamps in fan/heat/light units). Defects will be rectified by replacement of the product purchased except where, in Schneider Electric's discretion, minor adjustments can be undertaken instead of replacement.

Where a product is replaced it shall be guaranteed for the balance of the original guarantee period. Schneider Electric will replace a product that is no longer available with another product to a value and with features Schneider Electric considers appropriate.

Defects occurring in the following instances are expressly excluded from this guarantee:

1. Power Surges;
2. Incorrect installation;
3. Electromagnetic interference;
4. Misuse, abuse, modification, or tampering with the product;

Schneider Electric is not responsible for the installation or removal of the product, freight forwarding charges, losses or damage in transit, or associated expenses.

If your Schneider Electric product fails to operate satisfactorily, please return it to the point where it was purchased.

To enable Schneider Electric to honour this guarantee you will need to produce satisfactory proof of purchase and this guarantee card.

Service outside the guarantee will be at your cost. Schneider Electric does not undertake that repair facilities or spare parts will be available for this product.

IMPORTANT: PLEASE RETAIN THIS GUARANTEE CARD

NAME: _____

ADDRESS: _____

POST CODE: _____

PURCHASED FROM: _____

SUBURB: _____

DATE OF PURCHASE: _____

NAME OF PRODUCT: _____

MODEL No: _____



New Zealand Head Office: PO Box 15 355, Auckland, New Zealand
 Telephone +64-9-829 0490, Fax +64-9-829 0491
 www.schneider-electric.co.nz

Australia Head Office: Locked Bag 5500, Baulkham Hills Business Centre,
 NSW 2153, Australia
 Telephone +61-2-9851 2800, Fax +61-2-9629 8540
 www.schneider-electric.com.au



TWO YEAR WARRANTY