

FITTING AND WIRING PDL 6312 TIMER ACCESSORY (Not included)

1. Remove the cover on the fan motor unit bracket.
2. Remove 2 motor wires from terminal block and re-connect to electronic board as shown in Wiring Diagram 2.
3. Connect the remaining electronic board and mains supply wires to terminal block and trigger switch as shown in Wiring Diagram 2. Ensure mains supply cable is fixed with the cable fastener.
4. Position electronic board into the motor unit bracket slots.
5. The timer can be pre-set from 3 to 20 minutes by adjusting the trimmer (**only adjust with all supply circuits switched off**).
6. Replace the cover on the fan motor unit bracket.

NOTE: The fan will automatically start up 20 seconds after light or trigger switch is on and will continue to operate for the time pre-set after the light or trigger switch is turned off. (Max. load of timer is 150W).

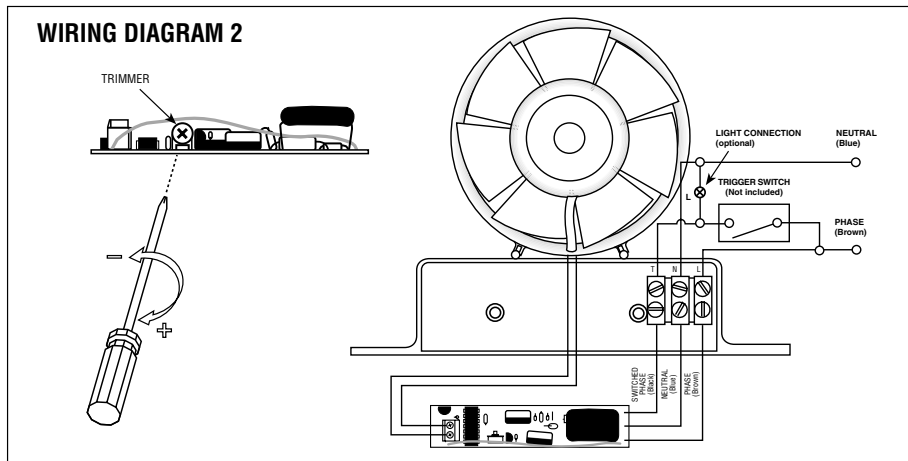

PDL EXHAUST FAN RANGE

IN-LINE EXHAUST FANS

6401 4" IN-LINE EXHAUST FAN

6501 5" IN-LINE EXHAUST FAN

6601 6" IN-LINE EXHAUST FAN

WALL/CEILING EXHAUST FANS

6402 4" WALL/CEILING EXHAUST FAN

6502 5" WALL/CEILING EXHAUST FAN

6602 6" WALL/CEILING EXHAUST FAN

ACCESSORIES (not included)

6412 4" THROUGH WALL KIT

– Includes: Square grille surround, Angled fixed grille, Gravity Louvres, Aluminium Ducting (115mm compacted, 320mm extended).

6512 5" THROUGH WALL KIT

– Includes: Square grille surround, Angled fixed grille, Gravity Louvres, Aluminium Ducting (115mm compacted, 320mm extended).

6612 6" THROUGH WALL KIT

– Includes: Square grille surround, Angled fixed grille, Gravity Louvres, Aluminium Ducting (115mm compacted, 320mm extended).

6312 ELECTRONIC TIMER (FOR IN-LINE EXHAUST FANS ONLY)

– Adjustable time : 3 to 20 minutes, Max Load : 150W

6322 ELECTRONIC TIMER (FOR WALL/CEILING EXHAUST FANS ONLY)

– Adjustable time : 3 to 20 minutes, Max Load : 150W

SPARES

GRILLES

6401G 4" IN-LINE ROUND GRILLE

6501G 5" IN-LINE ROUND GRILLE

6601G 6" IN-LINE ROUND GRILLE

DUCTING

6401D 4" IN-LINE DUCTING 3m

6501D 5" IN-LINE DUCTING 4m

6601D 6" IN-LINE DUCTING 6m

MOTORS

6401M 4" IN-LINE MOTOR

6501M 5" IN-LINE MOTOR

6601M 6" IN-LINE MOTOR



IN-LINE EXHAUST FANS

Models 6401, 6501, 6601

OPERATING INSTRUCTIONS

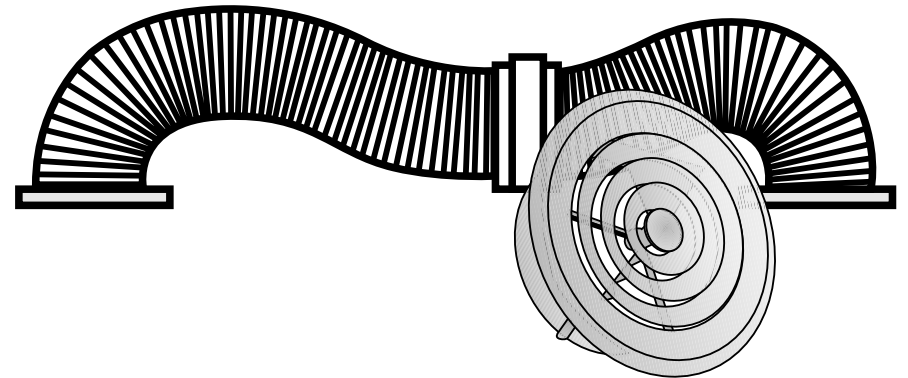

GENERAL INFORMATION

- Precautions must be taken to avoid the back-flow of gases into the room from the open flue of gas or other open-fire appliances.
- This fan should not be used for the extraction of combustible gases or vapour.
- **WARNING:** Before obtaining access to terminals, **all** supply circuits must be disconnected.
- The appliance is not intended for use by young or infirm persons without supervision.
- Young children should be supervised to ensure that they do not play with the appliance.
- Ensure that a suitable disconnection switch is installed in the fixed wiring, in accordance with the local wiring rules and regulations.
- **Do not install within 120cm of a stove.**

SPECIFICATIONS

	MODEL		
	6401	6501	6601
Ducting Diameter(mm/inches)	100/4"	120/5"	150/6"
Duty At Free Discharge (m ³ /h)	85	130	230
Nominal Air Flow Pressure (mmH2O)	0.65	0.30	0.80
Voltage	230-240 Volts	230-240 Volts	230-240 Volts
Frequency	50Hz	50Hz	50Hz
Wattage	11	15	29
Sound Pressure Level At 1.5m db (A)	44	46	50
Insulation Class	II	II	II
Protection	IPX2	IPX2	IPX2
Max Running Temperature	40°C	40°C	40°C

INSTALLATION INSTRUCTIONS

INSTALLATION (NB: the fan motor unit must only be mounted indoors)

1. Remove all parts from packaging.
2. Determine and locate positions to place the inlet grille (indoor ceiling), outlet grille (outdoor soffit) and motor unit (joist inside the ceiling). Ensure the grille areas are free from obstruction and between 2 studs or joists. NB: The shortest possible distance between the grilles is recommended for optimum performance.
3. Inside the roof ceiling, mount the motor unit to a joist using screws provided, ensuring it is held firmly to reduce vibrations. **Ensure the airflow direction label is pointing towards the outlet grille.**
4. To ensure ducting will be fully retained, stick one piece of foam tape around both circumferences of the duct at each end of motor unit (see Figure 1).
5. Drill two small witness holes to mark each position in ceiling and outdoor soffit (for inlet and outlet grilles).
6. Attach flexible ducting to inlet side of motor unit duct (completely over foam tape). Secure with one of the straps provided.
7. Stretch out a good, adequate length of the flexible ducting to reach the marked inlet grille hole position and cut. **Ensure there is adequate length of flexible ducting to reach both grilles prior to cutting.**
8. Attach remaining flexible ducting to outlet side of motor unit duct (completely over foam tape). Secure with one of the straps provided.
9. Stretch out the flexible ducting to reach near the marked outlet grille hole position and cut.
10. From the inside, locate marked hole position in ceiling for the inlet grille to be fitted and cut hole:

Model	Cut hole diameter	Alternatively, use this card as a template for marking appropriate hole size.
6401	119mm	
6501	144mm	
6601	169mm	



11. To ensure ducting will be fully retained, stick one piece of foam tape around the circumference of the duct at the end of the inlet grille surround (see Figure 1).
12. Reach into inlet ceiling hole and pull flexible ducting through. Attach flexible ducting to inlet grille surround duct (completely over foam tape). Secure with one of the straps provided.
13. Carefully un-clip centre grille from the grille surround. Insert the inlet grille surround into the ceiling hole.
14. Secure the grille surround by turning the 3 clamp screws clockwise until the surround is flush against the surface. Do not over-tighten the screws.
15. Clip centre grille back into the inlet grille surround.
16. Repeat steps 10 to 15 for mounting the outlet grille to the outdoor soffit.

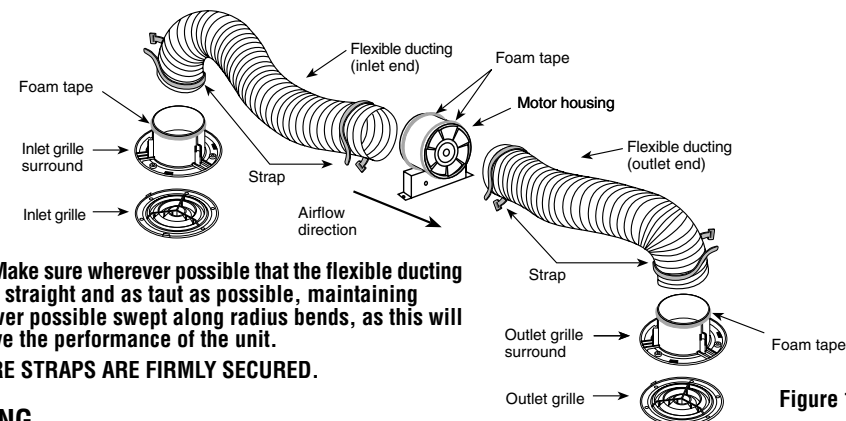

Note: Make sure wherever possible that the flexible ducting is kept straight and as taut as possible, maintaining wherever possible swept along radius bends, as this will improve the performance of the unit.

ENSURE STRAPS ARE FIRMLY SECURED.

WIRING

Note: All wiring must be securely fixed and the supply cable must be a minimum of 1mm² in section and maximum cable outside diameter is to be 7mm. All wiring must comply with the current regulations.

IMPORTANT: Switch off mains supply before making any electrical connections.

STANDARD MODELS (Wiring Diagram 1)

1. Remove the cover on the fan motor unit bracket.
2. Check that the wiring from the motor is held firmly in the terminal block.
3. Connect the mains supply as shown in Wiring Diagram 1, ensuring mains supply cable is fixed with cable fastener.
4. Replace the cover on the fan motor unit bracket.

