



PDL BOOSTER SWITCH

Installation and consumer operating instructions for Cat 548BS Booster Switch

FEATURES

Your PDL Cat 548BS Booster Switch is designed to operate only when a voltage across the line terminals is present. This makes it ideal for use with a solar water heating system to provide a boost of electric heat when water usage exceeds the capabilities of the system.

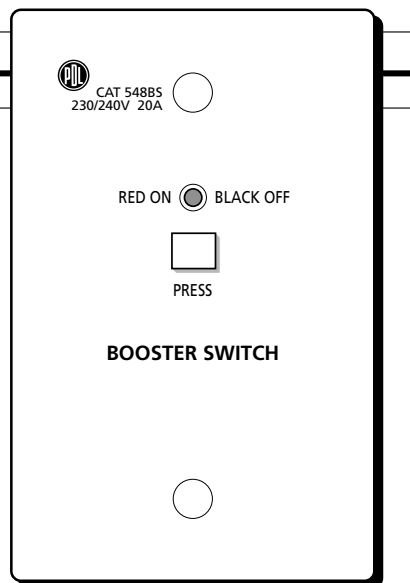

IMPORTANT NOTES

- The 548BS is a voltage held switching relay which drops out the output voltage across the LOAD terminals when the input voltage across the LINE terminals has been removed and does not reinstate it until the start button has been pushed.
- It is normal for the front panel to be slightly warm during use.
- Ensure MCB or HRC fuses rated at 20A max. are installed in your distribution board to prevent damage to your booster switch.
- The 548BS includes double pole switching

CLEANING INSTRUCTIONS

Use a clean damp cloth to wipe down unit.

INSTALLATION INSTRUCTIONS

Before wiring, ensure the supply is disconnected at the distribution board and study the diagram below before commencing work. Be careful not to connect the supply to any terminal other than indicated in the diagram and on the product. Ensure the unit is wired in compliance with local wiring regulations.

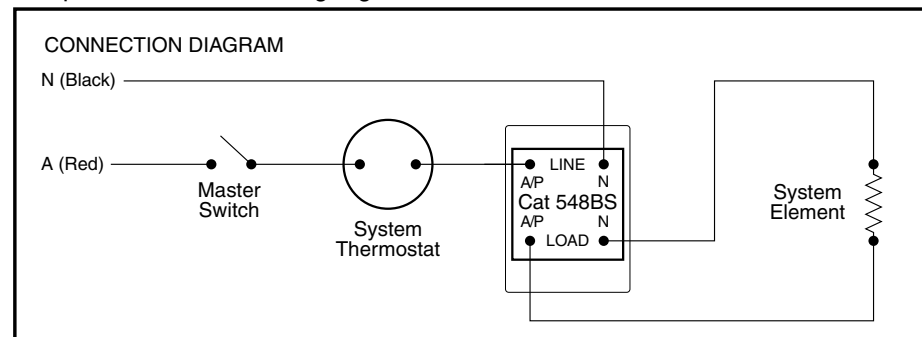

Note: Ensure correct earthing is used throughout the circuit.

SPECIFICATIONS

Mounting centres	84mm
Rating	230 - 240V a.c. 50Hz
Rated current	20A
Maximum load	4800W
Power consumption	1.60W at 240V
Type Tested to AS/NZS3100	

PRODUCT WARRANTY / 12 MONTHS

The 548BS Booster Switch has a 12 month warranty from the date of purchase providing the unit is installed according to these instructions, local wiring regulations and Codes of Practice. This warranty is void on any unit which has been tampered with, damaged by accident, improper operation or incorrect installation.

This guarantee is in addition to, and does not in any way affect the rights under the Consumer Guarantees Act 1993, if the ACT applies to the supply of this product and you are not acquiring the product for a business use. If the ACT applies and any term is inconsistent with the terms or requirements of the ACT that term shall be invalid without affecting the remaining terms of the warranty.

Note: Under the CGA 1993, Schneider Electric advises that this product does not contain user serviceable components thus spare parts and repair facilities are not available.

In the event of a warranty claim, the product must be returned to the point of purchase or direct to Australia/New Zealand distributors together with the proof of purchase.



PDL

New Zealand Head Office: PO Box 15 355, Auckland, New Zealand
Telephone +64-9-829 0490, Fax +64-9-829 0491
www.schneider-electric.co.nz

Australia Head Office: Locked Bag 5500, Baulkham Hills Business Centre,
NSW 2153, Australia
Telephone +61-2-9851 2800, Fax +61-2-9629 8340
www.schneider-electric.com.au

