

Altivar Soft Starter ATS430

ATS22 to ATS430 Modernization Manual

BQT74917.01

09/2025



Legal Information

The information provided in this document contains general descriptions, technical characteristics and/or recommendations related to products/solutions.

This document is not intended as a substitute for a detailed study or operational and site-specific development or schematic plan. It is not to be used for determining suitability or reliability of the products/solutions for specific user applications. It is the duty of any such user to perform or have any professional expert of its choice (integrator, specifier or the like) perform the appropriate and comprehensive risk analysis, evaluation and testing of the products/solutions with respect to the relevant specific application or use thereof.

The Schneider Electric brand and any trademarks of Schneider Electric SE and its subsidiaries referred to in this document are the property of Schneider Electric SE or its subsidiaries. All other brands may be trademarks of their respective owner.

This document and its content are protected under applicable copyright laws and provided for informative use only. No part of this document may be reproduced or transmitted in any form or by any means (electronic, mechanical, photocopying, recording, or otherwise), for any purpose, without the prior written permission of Schneider Electric.

Schneider Electric does not grant any right or license for commercial use of the document or its content, except for a non-exclusive and personal license to consult it on an "as is" basis.

Schneider Electric reserves the right to make changes or updates with respect to or in the content of this document or the format thereof, at any time without notice.

To the extent permitted by applicable law, no responsibility or liability is assumed by Schneider Electric and its subsidiaries for any errors or omissions in the informational content of this document, as well as any non-intended use or misuse of the content thereof.

Table of Contents

Safety Information.....	5
About the document	7
Modernization Procedure Overview.....	15
Inventory of the existing ATS22	16
Compare Characteristics.....	17
Step 1 : Check supply specifications and compliance with ATS430 characteristics	18
Step 2: Check information related to mechanical installation :.....	19
Step 3: Check power drawing and wiring	21
Step 4: Check power installation	22
Step 5: Check control wiring	23
Step 6: Check thermal monitoring method	24
Step 7: Check the ATS22 configuration of the basic parameters	25
Step 8: Check the ATS22 configuration of the expert parameters	27
Step 9: Check your Communication Method and Configuration	29
Install the new product ATS430	30
Step 10: Mechanical installation	31
Step 11: Power Wiring.....	35
Step 12: Control Wiring	37
Step 13: Application diagram	38
Step 14: Layout of control terminals	40
Step 15: Check basic ATS430 software parameters	42
Step 16: Check expert ATS430 software parameters.....	45
Step 17: Check ATS430 software add-on functionalities or monitoring versus ATS22.....	55
Step 18: Start and monitor application	56
Step 19: HMI monitoring and Diagnostic	57
Additional Support	58
Glossary	60

Safety Information

Important Information

Read these instructions carefully, and look at the equipment to become familiar with the device before trying to install, operate, service, or maintain it. The following special messages may appear throughout this documentation or on the equipment to warn of potential hazards or to call attention to information that clarifies or simplifies a procedure.



The addition of this symbol to a “Danger” or “Warning” safety label indicates that an electrical hazard exists which will result in personal injury if the instructions are not followed.



This is the safety alert symbol. It is used to alert you to potential personal injury hazards. Obey all safety messages that follow this symbol to avoid possible injury or death.

DANGER

DANGER indicates a hazardous situation which, if not avoided, **will result in death or serious injury**.

WARNING

WARNING indicates a hazardous situation which, if not avoided, **could result in death or serious injury**.

CAUTION

CAUTION indicates a hazardous situation which, if not avoided, **could result in minor or moderate injury**.

NOTICE

NOTICE is used to address practices not related to physical injury.

Please Note

Electrical equipment should be installed, operated, serviced, and maintained only by qualified personnel. No responsibility is assumed by Schneider Electric for any consequences arising out of the use of this material.

A qualified person is one who has skills and knowledge related to the construction and operation of electrical equipment and its installation, and has received safety training to recognize and avoid the hazards involved.

Qualification of Personnel

Only appropriately trained persons who are familiar with and understand the contents of this manual and all other pertinent product documentation are authorized to work on and with this product. In addition, these persons must have received safety training to recognize and avoid hazards involved. These persons must have sufficient technical training, knowledge and experience and be able to foresee and detect potential hazards that may be caused by using the product, by changing the settings and by the mechanical, electrical and electronic equipment of the entire system in which the product is used. All persons working on and with the product must be fully familiar with all applicable standards, directives, and accident prevention regulations when performing such work.

Intended Use

This product is intended for industrial use according to this manual.

The product may only be used in compliance with all applicable safety standard and local regulations and directives, the specified requirements and the technical data. The product must be installed outside the hazardous ATEX zone. Prior to using the product, you must perform a risk assessment in view of the planned application. Based on the results, the appropriate safety measures must be implemented. Since the product is used as a component in an entire system, you must ensure the safety of persons by means of the design of this entire system (for example, machine design). Any use other than the use explicitly permitted is prohibited and can result in hazards.

About the document

Document Scope

The purpose of this document is:

- to give you mechanical and electrical information to replace the ATS22 with an ATS430,
- to show you how to configure ATS430 according to ATS22 configuration,
- to highlight the firmware and communication differences between ATS22 and ATS430 that impact the replacement.

Validity Note

Original instructions and information given in the present document have been written in English (before optional translation).

This documentation is valid for the Altivar Soft Starter ATS430.

The characteristics of the products described in this document are intended to match the characteristics that are available on www.se.com. As part of our corporate strategy for constant improvement, we may revise the content over time to enhance clarity and accuracy. If you see a difference between the characteristics in this document and the characteristics on www.se.com, consider www.se.com to contain the latest information.

Product Related Information

Read and understand these instructions before performing any procedure with this soft starter.

DANGER

HAZARD OF ELECTRIC SHOCK, EXPLOSION, OR ARC FLASH

- Only appropriately trained persons who are familiar with and fully understand the contents of the present manual and all other pertinent product documentation and who have received all necessary training to recognize and avoid hazards involved are authorized to work on and with this equipment.
- Installation, adjustment, repair and maintenance must be performed by qualified personnel.
- Verify compliance with all local and national electrical code requirements as well as all other applicable regulations with respect to grounding of all equipment.
- Only use properly rated, electrically insulated tools and measuring equipment.
- Do not touch unshielded components or terminals with voltage present.
- Prior to performing any type of work on the equipment, block the motor shaft to prevent rotation.
- Insulate both ends of unused conductors of the motor cable.

Failure to follow these instructions will result in death or serious injury.

DANGER

HAZARD OF ELECTRIC SHOCK, EXPLOSION, OR ARC FLASH

Before performing work on the equipment:

- Use all required personal protective equipment (PPE).
- Disconnect all power, including external control power that may be present. Take into account that the circuit breaker or main switch does not de-energize all circuits.
- Place a "Do Not Turn On" label on all power switches related to the equipment.
- Lock all power switches in the open position.
- Verify the absence of voltage using a properly rated voltage sensing device.

Before applying voltage to the equipment:

- Verify that the work has been completed and that the entire installation cannot cause hazards.
- If the mains input terminals and the motor output terminals have been grounded and short-circuited, remove the ground and the short circuits on the mains input terminals and the motor output terminals.
- Verify proper grounding of all equipment.
- Verify that all protective equipment such as covers, doors, grids is installed and/or closed.

Failure to follow these instructions will result in death or serious injury.

DANGER

HAZARD OF ELECTRIC SHOCK, EXPLOSION, OR ARC FLASH

- Never operate energized switch with door open.
- Turn off switch before removing or installing fuses or making load side connections.
- Do not use renewable link fuses in fused switches.

Failure to follow these instructions will result in death or serious injury.

Damaged products or accessories may cause electric shock or unanticipated equipment operation.

DANGER

ELECTRIC SHOCK OR UNANTICIPATED EQUIPMENT OPERATION

Do not use damaged products or accessories.

Failure to follow these instructions will result in death or serious injury.

Contact your local Schneider Electric sales office if you detect any damage whatsoever.

This equipment has been designed to operate outside of any hazardous location. Only install this equipment in zones known to be free of a hazardous atmosphere.

DANGER

POTENTIAL FOR EXPLOSION

Install and use this equipment in non-hazardous locations only.

Failure to follow these instructions will result in death or serious injury.

Your application consists of a whole range of different interrelated mechanical, electrical, and electronic components, the device being just one part of the application. The device by itself is neither intended to nor capable of providing the entire functionality to meet all safety-related requirements that apply to your application. Depending on the application and the corresponding risk assessment to be conducted by you, a whole variety of additional equipment is required such as, but not limited to, external monitoring devices, guards, etc.

As a designer/manufacturer of machines, you must be familiar with and observe all standards that apply to your machine. You must conduct a risk assessment and determine the appropriate Performance Level (PL) and/or Safety Integrity Level (SIL) and design and build your machine in compliance with all applicable standards. In doing so, you must consider the interrelation of all components of the machine. In addition, you must provide instructions for use that enable the user of your machine to perform any type of work on and with the machine such as operation and maintenance in a safe manner.

The present document assumes that you are fully aware of all normative standards and requirements that apply to your application. Since the device cannot provide all safety-related functionality for your entire application, you must ensure that the required Performance Level and/or Safety Integrity Level is reached by installing all necessary additional equipment.

▲ WARNING

INSUFFICIENT PERFORMANCE LEVEL/SAFETY INTEGRITY LEVEL AND/OR UNINTENDED EQUIPMENT OPERATION

- Conduct a risk assessment according to EN ISO 12100 and all other standards that apply to your application.
- Use redundant components and/or control paths for all critical control functions identified in your risk assessment.
- Implement all monitoring functions required to avoid any type of hazard identified in your risk assessment, for example, slipping or falling loads.
- Verify that the service life of all individual components used in your application is sufficient for the intended service life of your overall application.
- Perform extensive commissioning tests for all potential error situations to verify the effectiveness of the safety-related functions and monitoring functions implemented, for example, but not limited to, speed monitoring by means of encoders, short circuit monitoring for all connected equipment, correct operation of brakes and guards.
- Perform extensive commissioning tests for all potential error situations to verify that the load can be brought to a safe stop under all conditions.

Failure to follow these instructions can result in death, serious injury, or equipment damage.

Product may perform unexpected movements because of incorrect wiring, incorrect settings, incorrect data or other errors.

▲ WARNING

UNANTICIPATED EQUIPMENT OPERATION

- Carefully install the wiring in accordance with the EMC requirements.
- Do not operate the product with unknown or unsuitable settings or data.
- Perform a comprehensive commissioning test.

Failure to follow these instructions can result in death, serious injury, or equipment damage.

⚠ WARNING

LOSS OF CONTROL

- The designer of any control scheme must consider the potential failure modes of control paths and, for critical control functions, provide a means to achieve a safe state during and after a path failure. Examples of critical control functions are emergency stop, overtravel stop, power outage and restart.
- Separate or redundant control paths must be provided for critical control functions.
- System control paths may include communication links. Consideration must be given to the implications of unanticipated transmission delays or failures of the link.
- Observe all accident prevention regulations and local safety guidelines (1).
- Each implementation of the product must be individually and thoroughly tested for proper operation before being placed into service.

Failure to follow these instructions can result in death, serious injury, or equipment damage.

(1) For USA: Additional information, refer to NEMA ICS 1.1 (latest edition), Safety Guidelines for the Application, Installation and Maintenance of Solid State Control.

Machines, controllers, and related equipment are usually integrated into networks. Unauthorized persons and malware may gain access to the machine as well as to other devices on the network/fieldbus of the machine and connected networks via insufficiently secure access to software and networks.

⚠ WARNING

UNAUTHORIZED ACCESS TO THE MACHINE VIA SOFTWARE AND NETWORKS

- In your hazard and risk analysis, consider all hazards that result from access to and operation on the network/fieldbus and develop an appropriate cyber security concept.
- Verify that the hardware infrastructure and the software infrastructure into which the machine is integrated as well as all organizational measures and rules covering access to this infrastructure consider the results of the hazard and risk analysis and are implemented according to best practices and standards covering IT security and cyber security (such as: ISO/IEC 27000 series, Common Criteria for Information Technology Security Evaluation, ISO/IEC 15408, IEC 62351, ISA/IEC 62443, NIST Cybersecurity Framework, Information Security Forum - Standard of Good Practice for Information Security, SE recommended Cybersecurity Best Practices*).
- Verify the effectiveness of your IT security and cyber security systems using appropriate, proven methods.

Failure to follow these instructions can result in death, serious injury, or equipment damage.

(*) : SE Recommended Cybersecurity Best Practices can be downloaded on SE.com.

⚠ WARNING

LOSS OF CONTROL

Perform a comprehensive commissioning test to verify that communication monitoring properly detects communication interruptions.

Failure to follow these instructions can result in death, serious injury, or equipment damage.

WARNING

RADIO INTERFERENCE

- In a domestic environment (B environment), this product may cause radio interference in which case supplementary mitigation measures may be required.

Failure to follow these instructions can result in death, serious injury, or equipment damage.

NOTICE

DESTRUCTION DUE TO INCORRECT MAINS VOLTAGE

Before switching on and configuring the product, verify that it is approved for the mains voltage.

Failure to follow these instructions can result in equipment damage.

General Cybersecurity Information

In recent years, the growing number of networked machines and production plants has seen a corresponding increase in the potential for cyber threats, such as unauthorized access, data breaches, and operational disruptions. You must, therefore, consider all possible cybersecurity measures to help protect assets and systems against such threats.

To help keep your Schneider Electric products secure and protected, it is in your best interest to implement the cybersecurity best practices as described in the [Cybersecurity Best Practices](#) document.

Schneider Electric provides additional information and assistance:

- [Subscribe to the Schneider Electric security newsletter.](#)
- [Visit the Cybersecurity Support Portal web page to:](#)
 - [Find Security Notifications.](#)
 - [Report vulnerabilities and incidents.](#)
- [Visit the Schneider Electric Cybersecurity and Data Protection Posture web page to:](#)
 - [Access the cybersecurity posture.](#)
 - [Learn more about cybersecurity in the cybersecurity academy.](#)
 - [Explore the cybersecurity services from Schneider Electric.](#)

Environmental Data

The Environmental Data Program is a framework for how we measure, categorize, and compare the environmental attributes and footprint of our products.

Using a rigorous, fact-based methodology, the program provides environmental data from across the product lifecycle.

Five data categories across the product lifecycle

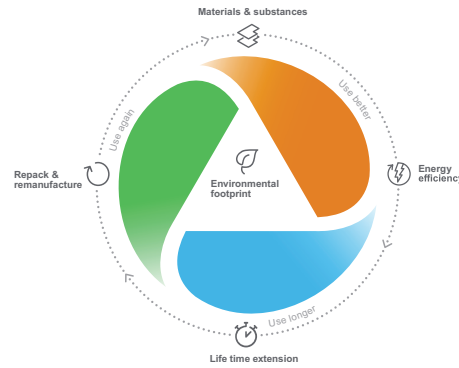

Use Better: How sustainable a product is, including environmental footprint, materials and substances, packaging, and energy efficiency.

Use Longer: How a product's life time can be effectively extended in terms of reparability and updatability.

Use Again: How a product can be reused, from dismantling and remanufacturing to recyclability and manufacturer take back.

With this transparent, verified data, customers and partners are empowered to make conscious environmental choices and accurately evaluate and report on sustainability performance.

All our hardware offers have an associated environmental data available on se.com product pages.

Refer to Environmental Data Program for more information.

Related Documents

Use your tablet or your PC to quickly access detailed and comprehensive information on all our products on www.se.com.

The internet site provides the information you need for products and solutions:

- The whole catalog for detailed characteristics and selection guides,
- The CAD files to help design your installation, available in over 20 different file formats,
- All software and firmware to maintain your installation up to date,
- A large quantity of White Papers, Environment documents, Application solutions, Specifications... to gain a better understanding of our electrical systems and equipment or automation,
- And finally all the User Guides related to your drive, listed below:

To find documents online, visit the Schneider Electric download center (www.se.com/ww/en/download/).

Catalog

Title of documentation	Reference number
Catalog: Altivar Soft Starter ATS430	DIA2ED2240602EN (English) DIA2ED2240602FR (French)

Documentations

Title of documentation	Reference number
ATS430 Getting Started	PKR63383 (English), PKR63384 (French) PKR63385 (Spanish), PKR63386 (Italian) PKR63387 (German), PKR63388 (Chinese) PKR63389 (Portuguese), PKR63390 (Turkish)
ATS430 Getting Started Manual Annex for UL	PKR63391 (English)
ATS430 User Manual	PKR63392 (English), PKR63393 (French) PKR63394 (Spanish), PKR63395 (Italian) PKR63396 (German), PKR63397 (Chinese) PKR63398 (Portuguese), PKR63399 (Turkish)
ATS22 User Manual	BBV51330 (English), BBV51329 (French)
ATS430 Embedded Modbus RTU Manual	PKR63401 (English)
ATS430 Communication Parameter Addresses	PKR63400 (English)
Recommended Cybersecurity Best Practices	CS-Best-Practices-2019–340 (English)

You can download these technical publications and other technical information from our website at www.se.com/en/download.

Videos

Title of documentation	Reference number
Video: Getting Started with ATS430	FAQ000263199 (English)

Software

Title of documentation	Catalog number
SoMove: FDT	SoMove FDT (English, French, German, Spanish, Italian, Chinese)
ATS430: DTM	ATS430 DTM Library EN (English – to be installed first) ATS430 DTM Lang FR (French) ATS430 DTM Lang SP (Spanish) ATS430 DTM Lang IT (Italian) ATS430 DTM Lang DE (German) ATS430 DTM Lang CN (Chinese)

Information on Non-Inclusive or Insensitive Terminology

As a responsible, inclusive company, Schneider Electric is constantly updating its communications and products that contain non-inclusive or insensitive terminology.

However, despite these efforts, our content may still contain terms that are deemed inappropriate by some customers.

Terminology used in this document

The technical terms, terminology, and the corresponding descriptions in this manual normally use the terms or definitions in the relevant standards.

In the area of soft starters this includes, but is not limited to, terms such as **error**, **error message**, **failure**, **fault**, **fault reset**, **protection**, **safe state**, **safety function**, **warning**, **warning message**, and so on.

Among others, these standards include:

- ISO 13849-1 & 2 Safety of machinery - safety related parts of control systems
- IEC 61158 series: Industrial communication networks - Fieldbus specifications
- IEC 61784 series: Industrial communication networks - Profiles
- IEC 60204-1: Safety of machinery - Electrical equipment of machines – Part 1: General requirements
- IEC 60947–1 Low–Voltage Switchgear and Control Gear – General rules
- IEC 60947–4-2 Semiconductor Motor controllers, Starters and Soft Starters
- IEC 62443: Security for industrial automation and control systems

In addition, the term **zone of operation** is used in conjunction with the description of specific hazards, and is defined as it is for a **hazard zone** or **danger zone** in the EC Machinery Directive (2006/42/EC) and in ISO 12100.

Also see the glossary at the end of this manual.

Contact us

Select your country on www.se.com/contact.

Schneider Electric Industries SAS

Head Office

35, rue Joseph Monier

92500 Rueil-Malmaison

France

Modernization Procedure Overview

Step	Action
1	<p>Make the inventory of the existing ATS22 installation:</p> <ul style="list-style-type: none"> Note the ATS22 commercial reference to replace by the ATS430 Note the installed ATS22 options and accessories: <p>For more information refer to Inventory of the existing ATS22, page 16.</p>
2	<p>Select the ATS430 commercial reference to replace the ATS22:</p> <ul style="list-style-type: none"> Select the soft starter reference with the ATS430 catalog or selector on se.com Select the display terminal and remote mounting kit to match the required IP protection degree
3	<p>Uninstall the ATS22 and install the ATS430:</p> <ul style="list-style-type: none"> Consider the differences between ATS22 and ATS430 Install the new display terminal and the remote mounting kit if used <p>For more information refer to Step 10: Mechanical installation , page 31.</p>
4	<p>Wire the ground, supply mains and motor supply of the newly installed ATS430:</p> <ul style="list-style-type: none"> Consider the differences between ATS22 and ATS430 <p>For more information refer to Step 11: Power Wiring, page 35.</p>
5	<p>Wire the control terminals of the newly installed ATS430:</p> <ul style="list-style-type: none"> Refer to the correspondence table between ATS22 and ATS430 control terminals <p>For more information refer to Step 12: Control Wiring, page 37 and Step 14: Layout of control terminals, page 40.</p>
6	<p>Before switching On, refer to “Checking Installation” in the ATS430 User Manual PKR63392.</p>
7	<p>Initialize the ATS430:</p> <ul style="list-style-type: none"> Set the language and date Set the cybersecurity policy of the ATS430 <p>This menu is displayed when the ATS430 is supplied for the first time.</p> <p>For more information refer to “First Power-Up” in the ATS430 User Manual PKR63392.</p>
8	<p>Configure your ATS430 in accordance with the previous configuration of the ATS22 and to your needs.</p> <p>For more information refer to Step 7, page 25, Step 8, page 27, Step 15, page 42 and Step 16, page 45.</p> <p>This concludes the substitution from the ATS22 to the ATS430.</p>

Inventory of the existing ATS22

What's in This Part

Compare Characteristics	17
Step 1 : Check supply specifications and compliance with ATS430 characteristics.....	18
Step 2: Check information related to mechanical installation :	19
Step 3: Check power drawing and wiring	21
Step 4: Check power installation.....	22
Step 5: Check control wiring	23
Step 6: Check thermal monitoring method	24
Step 7: Check the ATS22 configuration of the basic parameters.....	25
Step 8: Check the ATS22 configuration of the expert parameters	27
Step 9: Check your Communication Method and Configuration	29

Compare Characteristics

Before changing or demounting your ATS22, please consider the characteristics of the ATS430.

Refer to the catalog for each range to confirm the latest values.

	ATS22	ATS430
Ue Power supply voltage	Q - 230/440 Vac	–
	S6 - 208 / 600 Vac	S6 -208 / 600 Vac
	S6U - 208 / 600 Vac	–
Tolerance	-15...+10%	-15...+10%
Power supply frequency	50...60 Hz	50...60 Hz
Tolerance	+/- 10%	+/- 20%
Us control supply voltage	Q - 230 Vac	–
	S6 - 230 Vac	S6 - 110...230 Vac
	S6U - 110 Vac	–
Tolerance	–	-15...+10%
Nb of Sizes	5	5
Calibres	15 (17-590A)	15 (17-590A)
Current Limit	–	500% Ie (700% rated motor current)
Achilles L2 certification	No	Yes
Time stamp with RTC	No	Yes
Environmental specifications		
Ambient Temp w/o derating	- 10°C (14°F) to 40°C (104°F)	- 25°C (-13°F) to 40°C (104°F)
Ambient Temp with derating	up to 60°C (140°F) by 2.2 % each ° over 40° C (104°F)	up to 60 °C (140 °F) by 1% each °C (1.8 °F)
Altitude wo derating	0-1000m (0...3300ft)	0-2000m (0-6600ft)
Altitude with derating	1000 to 2000m (3300...6600ft) by 2 % each 100m	2000 to 4800m(6600...15700ft) by 1 % each 100m
Degree of protection	IP20 for ATS22D17...C11	IP20 for ATS430D17S6 to C11S6
	IP00 for ATS22C14...C59	IP00 for ATS430C14S6 to C59S6
Vibration resistance IEC 60721-3-3	1.5 mm/0.06 in. from 2 to 13 Hz / 1 gn from 13 to 200 Hz	1.5 mm/0.06 in. from 2 to 13 Hz / 1 gn from 13 to 200 Hz
Shock resistance IEC 60068-2-27	15 gn for 11 ms	15 gn for 11 ms
Maximum ambient pollution degree IEC 60664-1	Degree 2	Level 3
Maximum relative humidity IEC 60068-2-3	95% non-condensing, no dripping water	5...95% without condensation or dripping water
Operating position	Install the ATS22 vertically, within ± 10° (other positions are not allowed)	Vertical at ± 30°
mounted side-by-side	the free space must be ≥ 50 mm (1.95 in.) / top-Bottom S ≥ 100 mm (4 in)	the free space must be ≥ 10 mm (0.4 in.) / top-Bottom S ≥ 100 mm (4 in)
Operating position	Install the ATS22 vertically, within ± 10° (other positions are not allowed)	Vertical at ± 30°

Step 1 : Check supply specifications and compliance with ATS430 characteristics

Note the values of the main parameters of your ATS22 :

Parameter	ATS22 Value
Nominal current	_____ A
Nominal power	_____ kW or HP
Mains supply voltage	_____ V
Frequency	_____ Hz
Control supply voltage	_____ V
Starting time	_____ s
Number of starts per hour	_____

Refer to the "Selection" chapter in the ATS22 User Manual, page 13 for more information.

Step 2: Check information related to mechanical installation :

Check environmental specification and compliance with the ATS430 characteristics :

Note the values of ATS22:

Loss of cubicle components at nominal point	_____	W
Minimum flow rate for cubicle ventilation	_____	m ³ /h
Internal power loss of the soft starter	_____	W
Main circuit power loss of the soft starter	_____	W
Additional fans	Yes	No
	Number if "Yes" : _____	

Refer to "Fans" section in the ATS22 Catalog DIA2ED2140606EN

Check installation in the cubicle :

Note the values of ATS22 :

Mounting position : Vertical / Inclined / Special	_____	
Size	_____	mm ²
Footprint	_____	mm ²
Depth	_____	mm
Weight	_____	kg
Free space around your ATS22	_____	mm ²

Refer to the "Dimensions and weights" chapter in the ATS22 User Manual, page 13 for more information.

Handling the soft starter:

A handling device must be used to handle references from ATS22C21*** to ATS22C59***, therefore they are supplied with lifting holes.

Anticipate tools and handling means.

Refer to the "Receiving and handling" chapter in the ATS22 User Manual, page 13 for more information.

Accessories installed:

Verify if the accessories in the list below are used with your ATS22:

Accessory	✓
Remote display terminal	
Communication cables	
Terminal protections	

Refer to "Options: dialog and configuration tools" section in the ATS22 Catalog
DIA2ED2140606EN

Step 3: Check power drawing and wiring

Check the current:

- Motor cabling (Star or Delta connection) :
NOTE: Inside delta connection is not available for Altivar Soft Starter ATS430.
- Upstream Protections
- Line contactor calibration
- Earth connection diagram (TN, TT, IT, other ..)
- Measured Cos Phi of the battery and the installed battery :% ;
kVAR
- Power supply with power generator (No/Yes)

Step 4: Check power installation

Check the current values of ATS22:

Parameter	Value
Main supply	_____ V
Mains supply wiring section	_____ mm ²
Motor and ground connection section	_____ mm ²
Bus bar and hole fixations quotation	_____ mm
Cables length compatibility with ATS430	

Step 5: Check control wiring

CL1/CL2 supply :

- ATS22xxxQ and ATS22xxxS6 are supplied with 230 Vac.
- ATS22xxxS6U is supplied with 110 Vac.

Inputs supply :

- ATS22xxxQ and ATS22xxxS6 inputs are supplied with 24 Vdc.
- ATS22xxxS6U inputs are supplied with 110 Vac.

Then check the following:

To check	Note
Control command method (2 or 3 wires)	
External control supply implementation and protection (110Vac or 230Vac)	
Optional Display Terminal mounting and wiring	Reference:

Refer to the “Wiring” section in the ATS22 User Manual, page 13 for more information on :

- Inputs/Outputs characteristics and wiring
- Layout of control terminal

Step 6: Check thermal monitoring method

Check PTC Characteristics and wiring if used. Refer to “Thermal Protection” in the ATS22 User Manual, page 13 for more information.

Step 7: Check the ATS22 configuration of the basic parameters

Parameter	ATS22 Value
Advanced mode LAC : On or Off	_____
Motor and application parameters:	
In	_____
IcL	_____
ILT (1)	_____
UIn	_____
Application basic settings:	
Acc	_____
Dec	_____
T90 or Tq0	_____
Command control management	
Stopping method : dEC or Edc	_____
Start-stop control : SSC	_____
I/O Configuration	
LI1	_____
LI2	_____
R1	_____
R2	_____
Thermal protection	
ItH	_____
PtC	_____

(1): About [**Current Limit**] **ILT** : The factory setting is set to 400%. On ATS22 the [**Current Limit**] setting was 350%. Verify that the setting will be compliant with your application.



Depending on the application, set the [**Current Limit**] parameter to allow the starting process in good condition.

Prepare a software backup or print the modified parameters using SoMove:

SoMove allows to print in pdf or Excel format the complete list of your ATS22 parameters.

Choose Excel format to have a short list of modified parameters.

In SoMove, the modified parameters are marked with a “pencil” icon, example below :

Code	Long Label	Current Value	Modified	Default Value
▼ Configuration				
IcL	Soft starter rated current	17 A		17 A
dLIA	Connection type	In line connection		In line connection
UIn	Line voltage	400 V		400 V
In	Motor rated current	12 A		15 A
Cod	Setting lock	Not locked		Not locked
LAC	Advanced mode	On		Off
▶ Settings				

- To export in Excel format in SoMove, click on **File > Export > Export To Excel File**

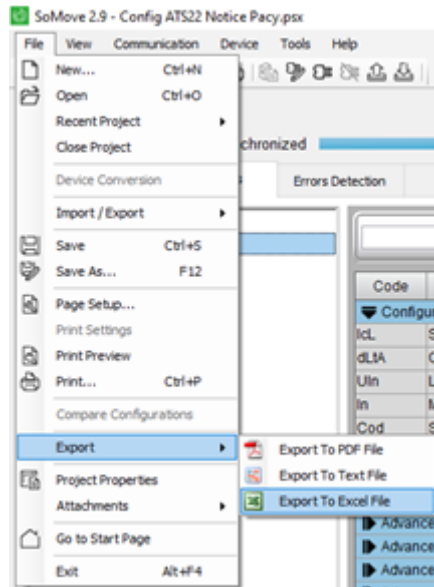

- Save the Excel file and use Data filter on the complete line of Title parameters to display only the modified parameters.

Step 8: Check the ATS22 configuration of the expert parameters

Applications / Environnement

Applications / Environnement	Supported by				Notes
	ATS22	Parameter	ATS430	Parameter	
Connection Inside the Delta motor connection	Yes for Q version	dLtA	No	—	Use a smaller ATS caliber than the motor current
Bypass embedded	Yes	—	Yes	—	—
Phases controlled	3	—	2	—	—
Normal duty	Yes	—	Yes	—	—
Optional fan Kit	Yes	—	No	—	Embedded on ATS430, optional for frame sizes ATS22D17 to C17. Refer to "Mounting - Fan option" in the ATS22 User Manual, page 13.
External 24Vdc control supply	No	—	Yes	—	Optional with ATS430, allows to supply HMI and communication card if Mains A1/A2 is not supplied.
Torque Control	Yes	—	Yes	—	—
Voltage Control	Yes	—	Yes	—	—
Soft Stopping	Yes	—	Yes	—	—
Electrical Braking	No	—	No	—	—
Number of starts	Yes	Snb	Yes.	TBS	Limiting the number of soft starts and soft stops during an adjustable period of time.
2 nd set for the 5 motor parameters	Yes	SEt2	No	—	Second motor on same Soft Starter
Undercurrent threshold	Yes	Uld	Yes	LUL	—
Overcurrent threshold	Yes	Old	Yes	LOC	—
Unbalance threshold	Yes	Ubd	Yes	CURT	Unbalanced main supply
Ground leakage current	Yes, adjustable threshold	Grdd	Yes, non-adjustable threshold	—	—
Phase sequence (123 or 132)	Yes	PHr	Yes	PHR	Mobile machine
Phase loss detection	Yes	PHL	Yes	PHP & PHL	Main supply by trolley or mobile connectors
Under voltage threshold	Yes	USd	Yes	USD	Weak power grid or generator
Over voltage threshold	Yes	oSd	Yes	OSD	Strong power grid or generator
PTC probes motor monitoring	Yes	PtC	Yes	TH1S	Internal motor protections
Overload protection	Yes	ItH	Yes	ODLA	Process monitoring
Firmware upgrades	No	—	Yes	FWUP	—
Cybersecurity governance	No	—	Yes	CYBS	—
Save & Restore parameters with the display terminal	No	—	Yes	SLF	—
RTC Management	No	—	Yes	—	—
Access security features Achilles Level 2	No	—	Yes	CYBS	—
Secure event logging	No	—	Yes	CYBS	—

	Available for ATS22 and ATS430
	Available on ATS430 only
	Not available on ATS430 or Different than ATS22

Inputs / Outputs:

Functions	Supported by			
	ATS22	Parameter	ATS430	Parameter
Start: for a 3-wire control	Yes	—	Yes	—
Run: for a 2-wire control	Yes	—	Yes	—
2nd set of parameters	Yes	SEt2	No	
External detected fault	Yes	EtF	Yes	ETF
Remote reset	Yes	rSt	Yes	RSF
Fan management	Yes	FAn	No	
Trip inhibition	Yes	Fi	Yes	INH
Forced local command	Yes	LiL	Yes	FLO
Stopped - Relay is energized at stop	Yes	StPd	NA	—
Not stopped - Relay is not energized at stop and is energized at all other times	Yes	nStP	NA	—
Starting - Relay is energized during the start process until the bypass contactor is closed	Yes	Strt	NA	—
Running - Relay is energized when the bypass contactor is closed	Yes	run	NA	—
Ready - Relay is energized when the soft starter is ready to be started (mains is connected, no trip and the maximum number of starts (Snb) is not reached)	Yes	rdY	NA	—
Trip - Relay is de-energized in case of trip	Yes	triP	Yes	FLT
Mains Contactor : Relay is de-energized in case of trip and at the end of deceleration ramp and when run command is not present.	No	—	Yes	LLC
Alarm - Relay is de-energized upon alarm, Overload alarm: thermal state of overload protection is above	Yes	ALr	NA	—
Setting lock	Yes	Cod	No (Covered by cybersecurity features)	—
Advanced mode	Yes	LAC	Yes	LAC
Secure event log	No	—	Yes	—
Fan diagnostic	No	—	Yes	FAN
Soft starter self test	Yes	tESt	No	—
Soft starter software version	Yes	udP	Yes	VIF
Back to factory settings	Yes	FCS	Yes	FCS
Reset of trip history and counters	No	—	Yes	RFLT
Energy dashboards	No	—	Yes	—
Alarm groups	No	—	Yes	AGP1

	Available for ATS22 and ATS430
	Available on ATS430 only
	Not available on ATS430 or Different than ATS22

Step 9: Check your Communication Method and Configuration

Physical connection:

Reminder that the ATS22 allows 2-wire connection to RS485 bus. Refer to the diagram and characteristics in the “Connection to RS485 bus” section in the ATS22 User Manual, page 13.

Parameters:

Check serial link parameters settled according to your PLC configuration :

Code	Parameter	ATS22 Value
Add	Modbus adress	
tbr	Modbus baudrate	
For	Modbus format	
tto	Modbus time out	

Refer to “Advanced communication menu” section in the ATS22 User Manual, page 13.

Install the new product ATS430

What's in This Part

Step 10: Mechanical installation	31
Step 11: Power Wiring	35
Step 12: Control Wiring.....	37
Step 13: Application diagram.....	38
Step 14: Layout of control terminals	40
Step 15: Check basic ATS430 software parameters	42
Step 16: Check expert ATS430 software parameters.....	45
Step 17: Check ATS430 software add-on functionalities or monitoring versus ATS22	55
Step 18: Start and monitor application.....	56
Step 19: HMI monitoring and Diagnostic	57

Step 10: Mechanical installation

Check environmental specifications and compliance with the ATS430 characteristics

Check installation in the enclose

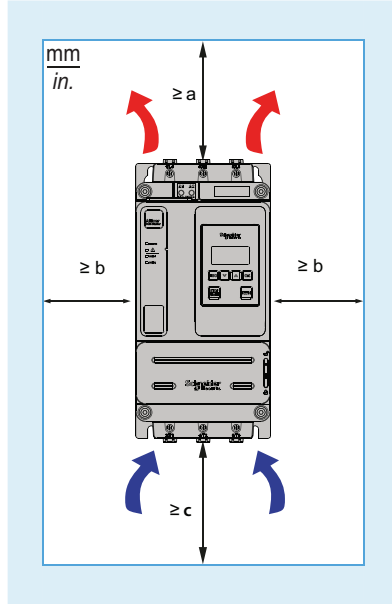

Install the ATS430 vertically, within $\pm 10^\circ$ (ATS22 was $\pm 30^\circ$)(other positions are not allowed).

NOTE: For the soft starters mounted side-by-side, the free space must be ≥ 10 mm (1.95 in.).

Handling and fastening method

A difference between ATS430 and ATS22 footprints is possible. Here is an example:

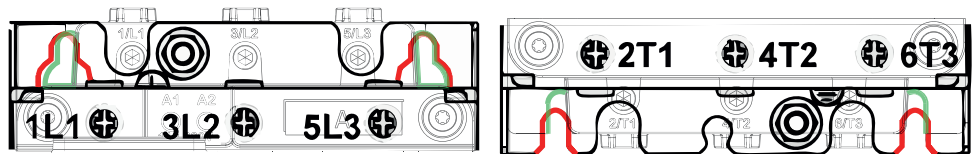

- **Red highlight:** ATS22
- **Green highlight:** ATS430

The tables below show these differences:

ATS430 — General Mechanical Information

References	Size	Height		Width		Depth		Weight (loss compare to ATS22)		Lifting lugs	Packaging
		mm	in	mm	in	mm	in	kg	lb		
ATS430D17S6	A	273 (+8)	10.7 (+0.31)	130	(5)	169	6.6	2.9 (-2.60)	6.4 (-5.73)	No	Cardboard box
ATS430D32S6	A	273 (+8)	10.7 (+0.31)	130	(5)	169	6.6	2.9 (-2.60)	6.4 (-5.73)	No	Cardboard box
ATS430D47S6	A	273 (+8)	10.7 (+0.31)	130	(5)	194 (+25)	7.6 (+0.98)	3.4 (-2.10)	7.5 (-4.63)	No	Cardboard box
ATS430D62S6	B	290 (-5)	11.4 (-0.2)	160 (+15)	6.3 (+0.58)	231 (+22)	9 (+0.86)	6.4 (-1.40)	14.1 (-3.08)	No	Cardboard box
ATS430D75S6	B	290 (-5)	11.4 (-0.2)	160 (+15)	6.3 (+0.58)	231 (+22)	9 (+0.86)	6.6 (-1.20)	14.5 (-2.64)	No	Cardboard box
ATS430D88S6	B	290 (-5)	11.4 (-0.2)	160 (+15)	6.3 (+0.58)	231 (+22)	9 (+0.86)	6.6 (-1.20)	14.5 (-2.64)	No	Cardboard box
ATS430C11S6	B	290 (-66)	11.4 (-2.58)	160 (+10)	6.3 (+0.4)	231 (+2)	9 (+0.07)	6.6 (-5.60)	14.5 (-12.34)	No	Cardboard box
ATS430C14S6	C	356	14.01	160 (+10)	6.3 (+0.4)	232 (+3)	9 (+0.11)	8.6 (-3.60)	18.9 (-7.93)	No	Cardboard box
ATS430C17S6	C	356	14.01	160 (+10)	6.3 (+0.4)	232 (+3)	9 (+0.11)	8.6 (-3.60)	18.9 (-7.93)	No	Cardboard box
ATS430C21S6	D	443 (+18)	17.44 (+0.7)	206	8.07	262 (-37)	10.4 (-1.45)	16.5 (-4.00)	36.4 (-8.82)	Yes	Pallet
ATS430C25S6	D	443 (+18)	17.44 (+0.7)	206	8.07	262 (-37)	10.4 (-1.45)	16.5 (-4.00)	36.4 (-8.82)	Yes	Pallet
ATS430C32S6	D	443 (+18)	17.44 (+0.7)	206	8.07	262 (-37)	10.4 (-1.45)	16.5 (-4.00)	36.4 (-8.82)	Yes	Pallet
ATS430C41S6	D	443 (+18)	17.44 (+0.7)	206	8.07	262 (-37)	10.4 (-1.45)	16.5 (-4.00)	36.4 (-8.82)	Yes	Pallet
ATS430C48S6	E	455	17.82	304	11.91	297 (-42)	11.65 (-1.64)	24.5 (-8.50)	54.01 (-18.74)	Yes	Pallet
ATS430C59S6	E	455	17.82	304	11.91	297 (-42)	11.65 (-1.64)	24.6 (-8.40)	54.23 (-18.52)	Yes	Pallet

NOTE:
+ : ATS430 is a higher value than ATS22
- : ATS430 is a lower value than ATS22

ATS430 — Fixation and holes

References	Distance between holes (standard)				Distance between holes (with fans)				Holes (Standard)				
	Horizontal		Vertical		Horizontal		Vertical		Diameters screws		4 screws	Ground section	
	mm	in	mm	in	mm	in	mm	in	mm	in			
ATS430D17S6	100	3.91	250	9.7	100	3.91	250	9.7	7	0.27	4 * M6	2 *M6	
ATS430D32S6	100	3.91	250	9.7	100	3.91	250	9.7	7	0.27	4 * M6	2 *M6	
ATS430D47S6	100	3.91	250	9.7	100	3.91	250	9.7	7	0.27	4 * M6	2 *M6	
ATS430D62S6	130 (+15)	5 (+0.58)	252 (-24)	9.87 (-0.94)	130 (+15)	5 (+0.58)	252 (-24)	9.87 (-0.94)	7	0.27	4 * M6	2 *M6	
ATS430D75S6	130 (+15)	5 (+0.58)	252 (-24)	9.87 (-0.94)	130 (+15)	5 (+0.58)	252 (-24)	9.87 (-0.94)	7	0.27	4 * M6	2 *M6	
ATS430D88S6	130 (+15)	5 (+0.58)	252 (-24)	9.87 (-0.94)	130 (+15)	5 (+0.58)	252 (-24)	9.87 (-0.94)	7	0.27	4 * M6	2 *M6	
ATS430C11S6	130 (+10)	5 (+0.4)	252 (-79)	9.87 (-3.09)	130 (+10)	5 (+0.4)	252 (-79)	9.87 (-3.09)	7	0.27	4 * M6	2 *M6	
ATS430C14S6	130 (+10)	5 (+0.4)	333 (+2)	13.04 (+0.07)	130 (+10)	5 (+0.4)	333 (+2)	13.04 (+0.07)	7	0.27	4 * M6	2 *M6	
ATS430C17S6	130 (+10)	5 (+0.4)	333 (+2)	13.04 (+0.07)	130 (+10)	5 (+0.4)	333 (+2)	13.04 (+0.07)	7	0.27	4 * M6	2 *M6	
ATS430C21S6	175 (+18)	6.85 (+0.7)	423 (+27)	16.57 (+1.05)	175 (+18)	6.85 (+0.7)	423 (+27)	16.57 (+1.05)	9	0.36	4 * M8	2*M8	
ATS430C25S6	175 (+18)	6.85 (+0.7)	423 (+27)	16.57 (+1.05)	175 (+18)	6.85 (+0.7)	423 (+27)	16.57 (+1.05)	9	0.36	4 * M8	2*M8	
ATS430C32S6	175 (+18)	6.85 (+0.7)	423 (+27)	16.57 (+1.05)	175 (+18)	6.85 (+0.7)	423 (+27)	16.57 (+1.05)	9	0.36	4 * M8	2*M8	
ATS430C41S6	175 (+18)	6.85 (+0.7)	423 (+27)	16.57 (+1.05)	175 (+18)	6.85 (+0.7)	423 (+27)	16.57 (+1.05)	9	0.36	4 * M8	2*M8	
ATS430C48S6	264	10.34	426	16.7	264	10.34	426	16.7	9	0.36	4 * M8	2*M10	
ATS430C59S6	264	10.34	426	16.7	264	10.34	426	16.7	9	0.36	4 * M8	2*M10	
NOTE:													
+ : ATS430 is a higher value than ATS22													
- : ATS430 is a lower value than ATS22													





Installing Door Mounting Kit

The ATS430 has an embedded Display Terminal

The VW3A1111 Graphic Display Terminal and the VW3A1113 Plain Text Display Terminal are available as options to replace the embedded Display Terminal.

Door mounting kits are available as options to mount the display terminal on the door of the enclosure.

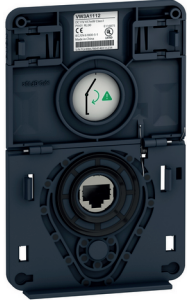
Refer to the following table to choose a display terminal and its door mounting kit.

Door Mounting Kit protection degree	Display terminal	Door mounting kit
IP43	VW3A1113 Plain Text Display Terminal Available as option 	VW3A1114 door mounting kit. Available as option  Refer to the instruction sheet EAV91355.
IP65	VW3A1111 Graphic Display Terminal Available as option 	VW3A1112 door mounting kit. Available as option  Refer to the instruction sheet EAV76406.
Select one of the following RJ45 cables to connect the remote mounting kit to the soft starter: <ul style="list-style-type: none"> • 1 meter: VW3A1104R10 • 3 meters: VW3A1104R30 Not included with the remote kit		

Step 11: Power Wiring

Power Wiring

		1/L1 3/L2 5/L3 and 2/T1 4/T2 6/T3 power supply and output to motor					
		Minimum required wire cross section (a)(b)		Tightening torque		Strip length	
References	Frame Size	mm ²	AWG	Nm	lb-in	mm	in
ATS430D17S6	A	2.5	12 (10)	5	44.25	17	0.66
ATS430D32S6	A	6	8	5	44.25	17	0.66
ATS430D47S6	A	10	8 (6)	5	44.25	17	0.66
ATS430D62S6	B	16	6 (4)	9	79.65	17	0.66
ATS430D75S6	B	25	4 (3)	9	79.65	17	0.66
ATS430D88S6	B	25 (-10)	3 (2)	9	79.65	17	0.66
ATS430C11S6	B	35	1 (1/0)	9	79.65	17	0.66

NOTE: Green: ATS22 data or difference with ATS430.

For Current level (100% of the soft starter rating)

(a) The cable gauge affects the IP protection degree. IP20 protection degree requires a minimum cable gauge of 16 mm² (4 AWG) and end caps. If this condition is not met, the IP protection degree is IP10.

(b) The cross section cable values are given for one cable per cages. The good behavior of the ATS430 is not assured with more than one cable per cages.

NOTE: Do not access to the power bars when the supply mains is On.

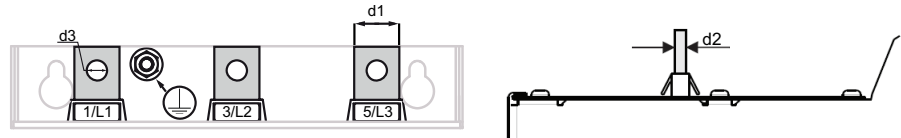

Power Wiring — Bar

		1/L1 3/L2 5/L3 and 2/T1 4/T2 6/T3 power supply and output to motor									
		Wire cross section (a) (b)		Tightening torque		d1		d2		d3	
References	Size	mm ²	AWG	Nm	lb-in	mm	in	mm	in	mm	in
ATS430C14S6	C	50	2/0	12	106.2	20	0.78	3 (-2)	0.11 (-0.07)	9	0.35
ATS430C17S6	C	70	3/0 (4/0)	12	106.2	20	0.78	3 (-2)	0.11 (-0.07)	9	0.35
ATS430C21S6	D	95	4/0 (350 kcmil)	44	389.4	30	1.17	5	0.19	13,5	0.52
ATS430C25S6	D	120	250 (350 kcmil)	44	389.4	30	1.17	5	0.19	13,5	0.52
ATS430C32S6	D	185	400 (2x3/0)	44	389.4	30	1.17	5	0.19	13,5	0.52
ATS430C41S6	D	240	2x250	44	389.4	30	1.17	5	0.19	13,5	0.52

Power Wiring — Bar (Continued)

		1/L1 3/L2 5/L3 and 2/T1 4/T2 6/T3 power supply and output to motor									
		Wire cross section (a) (b)		Tightening torque		d1		d2		d3	
References	Size	mm ²	AWG	Nm	lb-in	mm	in	mm	in	mm	in
		(2x150)									
ATS430C48S6	E	2x150	2x250 (2x350 kcmil)	44	389.4	40	1.56	5	0.19	13,5	0.52
ATS430C59S6	E	2x185	2x350 (2x500 kcmil)	44	389.4	40	1.56	5	0.19	13,5	0.52

NOTE: Green: ATS22 data or difference with ATS430.

For Current level (100% of the soft starter rating)

(a) The cable gauge affects the IP protection degree. IP20 protection degree requires a minimum cable gauge of 16 mm² (4 AWG) and end caps. If this condition is not met, the IP protection degree is IP10.

(b) The cross section cable values are given for one cable per cages. The good behavior of the ATS430 is not assured with more than one cable per cages.

Ground Connection Characteristics

References	Size	Section		Tightening Torque		Screw size
		mm ²	AWG	Nm	lb-in	
ATS430D17S6	A	10	8	5	44.25	M6
ATS430D32S6						
ATS430D47S6						
ATS430D62S6	B	16	6	5	44.25	M6
ATS430D75S6						
ATS430D88S6						
ATS430C11S6	C	35	3	5	44.25	M6
ATS430C14S6						
ATS430C17S6						
ATS430C21S6	D	150	250 kcmil	12	106.2	M8
ATS430C25S6						
ATS430C32S6						
ATS430C41S6	E	185	350 kcmil	24	212.41	M10
ATS430C48S6						
ATS430C59S6						

Step 12: Control Wiring

To control the motor, the ATS430 must be supplied in 110...230 Vac via the left upper terminals A1 and A2 on the power bloc.

NOTE: A1 A2 terminals are in the upper side of the ATS430. The wiring may be adapted compared to CL1/CL2 of ATS22 where the terminals were in the bottom control connector.

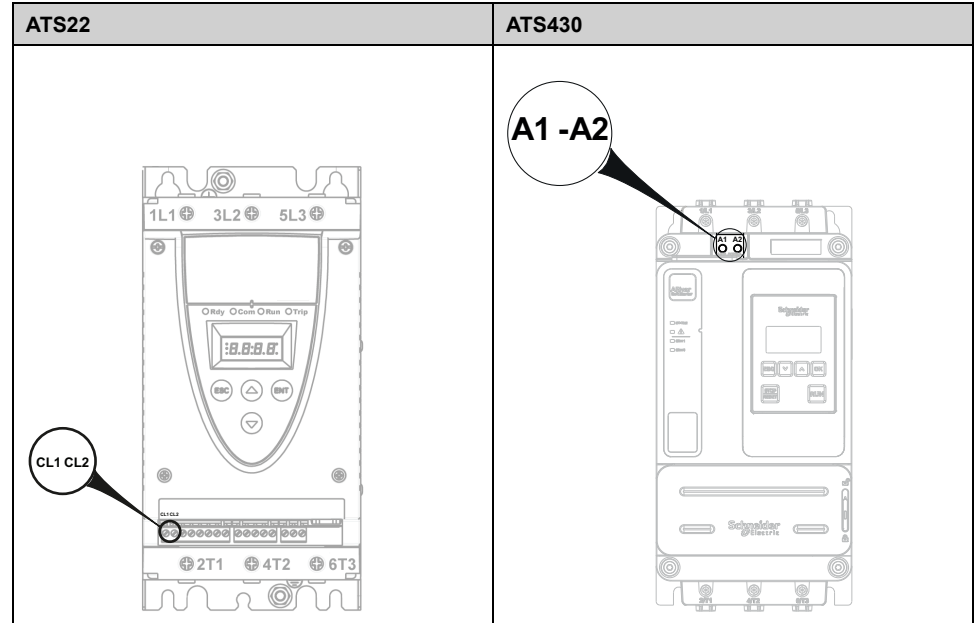

To maintain communication with the soft starter when A1 and A2 are absent, the ATS430 control part may be supplied in 24 Vdc via the terminal +24.

- U_{min} : 19 Vdc
- $U_{nominal}$: 24 Vdc
- U_{max} : 30 Vdc
- I_{max} : 200 mA

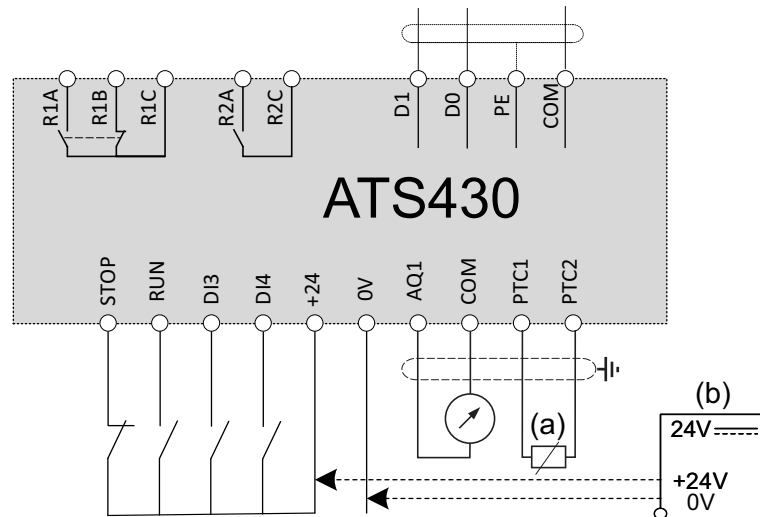

- (a): 2 wire PTC
- (b): optional

Step 13: Application diagram

Diagram

This “almost identical” diagram was proposed in ATS22 range. For other diagrams, refer to the ATS22 User Manual, page 13.

The ATS430 is managed by Stop and Run command inputs in 3 wires control mode.

With this diagram, the ATS430 :

- May manage the braking phase when the user stops the equipment by pressing S4. Mains contactor is maintained on Start/Stop commands.
- Is starting with S5 button validation.
- May restart automatically depending on the ATS430 mode management.
- Stop in freewheel mode when error is detected, Emergency stop **S1** is pressed, or mains supply is interrupted.

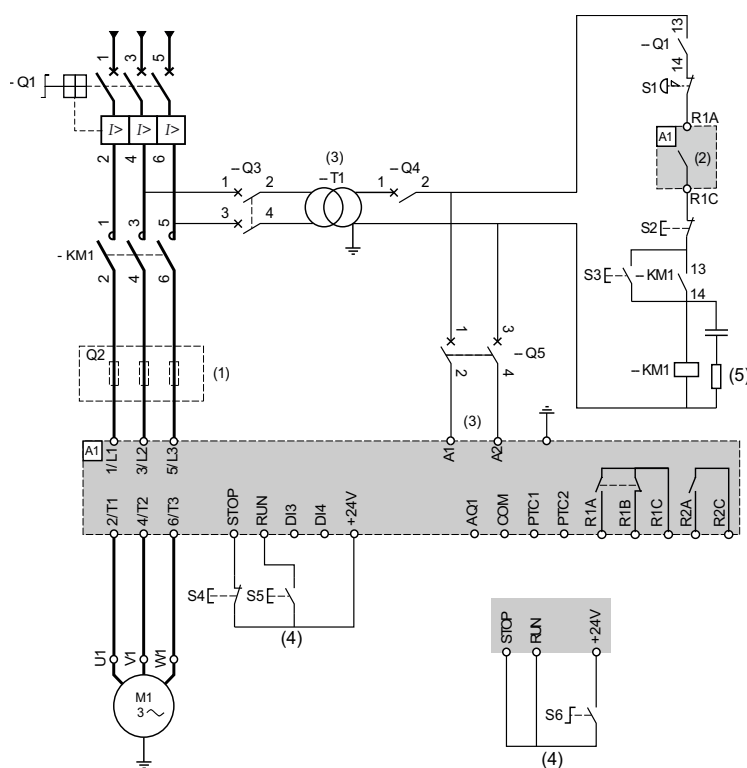

- (1) Installation of additional fast-acting fuses is mandatory to upgrade to type 2 coordination according to IEC 60947–4–2.
- (2) Take into account the electrical characteristics of the relays, refer to the ATS430 User Manual, page 13.
- (3) The transformer must supply 110...230 Vac –15%...+10%, 50/60Hz.
- (4) 3–wire control and 2–wire control. Refer to the ATS430 User Manual, page 13.
- (5) To select the appropriate voltage surge suppressor refer to the ATS430 User Manual, page 13.

Designation	Component	Description
Q1	Circuit breaker	Short circuit protection device for the motor
Q2	Circuit breaker	Short circuit protection device for the primary of the transformer
Q3	Fast acting fuses	Short circuit protection device of the soft starter to be used only when type 2 coordination
Q4	Circuit breaker	Short circuit protection device for the secondary of the transformer
Q5	Circuit breaker	Short circuit protection device for the control part of the soft starter
KM1	Contacteur	Line contactor

Designation	Component	Description
S1	Emergency Stop push-button	Emergency Stop to de-energized KM1 line contactor
S2	Normally close push-button	Power OFF
S3	Normally open push-button	Power ON
S4	Normally close contact push-button	STOP command for 3-wire control
S5	Normally open contact push-button	RUN command for 3-wire control
S6	Selector switch, 2 positions, stay-put, normally open contact	RUN/STOP command for 2-wire control

Relays information

Differences with: <ul style="list-style-type: none"> • ATS22 diagram : r1 nStP the relay is not activated at standstill and is activated in all other cases • ATS22 diagram : r2 trIP Trip relay is de-energized upon trip • ATS430 diagram : R1 relay is affected to [Operating State Fault] <p>NOTE: If the ATS22 diagram is used to implement a new ATS430, connect the 2 wires R2A – R2C on ATS22 to R1A – R1C on ATS430. Modify the machine drawing consequently.</p>		
ATS430 configuration	R1 = [Operating State Fault]	R1 is closed when the soft starter is supplied and no error is detected. R1 is opened when an error is detected or when the soft starter control supply A1/A2 is lost. (factory setting)
	R2 = NO	

Reset information

<p>NOTE: In the Warning Handling menu, [Product restart] set to Yes allows to reset the ATS430 by pressing and holding the OK button on the display terminal for 2 seconds. The Restart function performs a Fault Reset and then restarts the device. During this Restart procedure, the device goes through the same steps as if it had been switched off and on again. Depending on the wiring and the configuration of the device, this may result in immediate and unanticipated operation.</p>
<p>NOTE: After an error is triggered, if you need to reset the ATS430 by an external contact, go to :</p> <ul style="list-style-type: none"> • DI3 & DI4 assignement in [Input/Output] menu • Or [Complete settings] ➔ [Error/Warn handling] ➔ [Fault Reset Assign]
<p>NOTE: In 3 wires control mode, applying a Run order when [Fault Reset Assign] is set to [Not Assigned] will reset the soft starter. A second Run order is necessary to restart the motor.</p>

Step 14: Layout of control terminals

ATS22

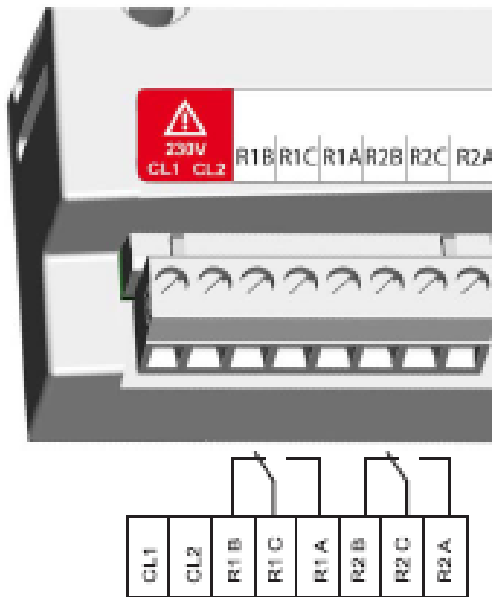

ATS430

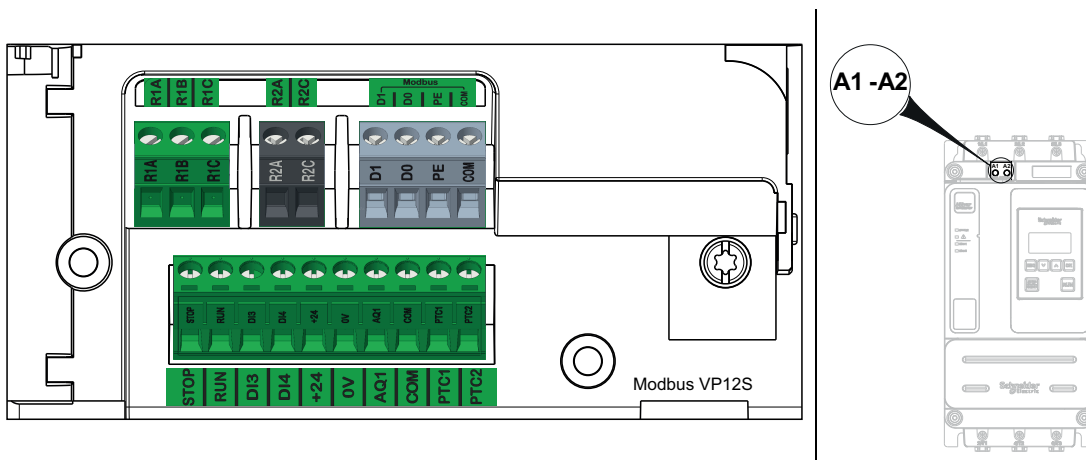

The corresponding terminals with ATS22 are :

	ATS430	ATS22
Logic inputs	STOP	LI1
	RUN	LI2
	DI3	LI3
	DI4	LI4
DC Supply	+24	24V
	0V	Com
Analog Output	AQ1	Non-equivalent terminal in ATS22
I/O common	COM	Com

	ATS430	ATS22
Motor thermal probes	PTC1	PTC1
	PTC2	PTC2
Control Supply	A1-A2	CL1-CL2

AQ1 is a analog output with 0-10V or 0-20mA allows to monitor a configurable signal as :

- **[Not Configured]: *Not configured.***
- **[Motor Current]: *Motor current.***
- **[Mot Mech Pwr %]: *Motor power in %.***
- **[Mot Thermal]: *Motor thermal state.***
- **[Power Factor]: *Power factor.***
- **[Motor Torque]: *Motor torque.***
- **[Reactive Power]: *Reactive Electrical input power.***

Step 15: Check basic ATS430 software parameters

Select languages

The device contains some languages than can be selected through **[Language]** in **[My preferences]** menu.

- English (default)
- Chinese
- French
- German
- Italian
- Korean
- Russian
- Spanish
- Traditional Chinese
- Turkish

When using the graphical terminal display, there are 2 additional available languages: Polish and Brazilian.

It is possible to upload additional languages.

Plain text display terminal	Graphic display Terminal	
The soft starter shall be upgraded (firmware update) with specific firmware which has to be prepared with adequate languages.	1.	Download the latest version of language files here: Languages_Drives_VW3A1111
	2.	Save the downloaded file on your computer.
	3.	Unzip the file and follow the instructions of the ReadMe text file.

Set date and time

This menu provides the parameters to set date and time. This information is used for the time stamping of all logged data.

Access path: **[Device Management] → [Date & Time]**

HMI label	Setting	Factory setting
[Set Date/Time] <i>DTO</i>	–	–
<p>Date and time information should be available (time server available and configured and the internal battery is functional) at soft starter power up to enable the time stamping of the logged data.</p> <p>Setting [Set Date/Time] gives access to the parameter [Time Zone], which can be used to set the offset between reference time and local time (by 15mn step).</p> <p>NOTE: The time is displayed in the top right-hand corner of the display terminal.</p>		
[Time Format] <i>TIMEF</i>	–	[24h]
<p>This parameter can be used to choose a time format to display on log file:</p> <ul style="list-style-type: none"> [24h]: Hour is displayed in a 24h format. [12h]: Hour is displayed in a 12h format. 		
[Date Format] <i>DATEF</i>	–	[yyyy/mm/dd]
<p>This parameter can be used to choose a date format to display on log file:</p> <ul style="list-style-type: none"> [yyyy/mm/dd]: Date is displayed as yyyy/mm/dd. [dd/mm/yyyy]: Date is displayed as dd/mm/yyyy. [mm/dd/yyyy]: Date is displayed as mm/dd/yyyy. [dd/mm/yy]: Date is displayed as dd/mm/yy. [dd/mm]: Date is displayed as dd/mm. 		

Duplicate basics ATS22 settings

Here under the basic settings of the ATS430.

NOTE: ATS430 connection inside delta is not available.

In Simply Start Menu :



Code	Long Label	Saved Value	Default Value	Min Value	Max Value
IN	Nominal current	233 A	233 A	100 A	250 A
ILT	Motor limiting current	400 %	400 %	150 %	535 %
ACC	Acceleration ramp time	15 s	15 s	1 s	180 s
T00	Initial starting torque	20 %	20 %	0 %	100 %
STT	Type of stop	Freewheel	Freewheel		

Report the ATS22 settings in the same parameters of the ATS430.

In Motor parameters Menu :



Code	Long Label	Saved Value	Default Value	Min Value
IN	Nominal current	233 A	233 A	100 A
ILT	Motor limiting current	400 %	400 %	150 %
ULN	Mains voltage	400 V	400 V	170 V
FRC	Mains frequency	Auto detection of mains frequency	Auto detection of mains frequency	

Check the **[Motor Nom Current]**.

This parameter is used to adjust the name plate value of the nominal current for the considered line or delta connection of the motor.

Be aware of 230 Vac delta / 400 Vac star motors and 400 Vac delta / 630 Vac star motors. To access to this menu, the **[Access Level]** needs to be set to **[Standard]** or to **[Expert]**.

Step 16: Check expert ATS430 software parameters

Mains Contactor Command

(Is not available for ATS22).

This menu provides the parameters to manage a line contactor upstream the soft starter. Refer to Step 13: Application diagram, page 38.

Access path: **[Complete settings] → [Mains contactor cmd]**

HMI label	Setting	Factory setting
[Mains Contactor] LLC	[Not Assigned] NO , [R1] or [R2]	[Not Assigned] NO

Mains contactor control

This parameter sets the external mains supply contactor command. The soft starter can command an external contactor placed upstream in the main supply via the relay R1 or R2, allowing to close or open the mains supply of the soft starter with a relay command.

If the function **[Mains Contactor]** LLC is set to R1, a factory settings will reset R1 to **[Operating State Fault]** and could apply, depending on the wiring diagram, voltage on the mains supply inputs via the mains contactor.

 **DANGER**

UNINTENDED PRESENCE OF VOLTAGE ON THE MAINS SUPPLY INPUTS

- Verify that restoring to factory setting when **[Mains Contactor]** LLC is set to R1 does not result in unsafe conditions.
- In case of doubt, prefer to set the parameter **[Mains Contactor]** LLC to another relay output.

Failure to follow these instructions will result in death or serious injury.

The relay command is based on the Run / Stop commands and the detected errors:

- The external contactor command is activated by a Run or Pre-heating command
- The mains contactor output is deactivated:
 - At the end of a deceleration or when the motor switches to freewheel after a Stop command.
 - When an error is detected.

NOTE: when line contactor is configured, the run command is considered in **NLP** state.

[Device Lock] LES	–	[Not Assigned] NO
--------------------------	---	--------------------------

Device lock assignment

This parameter sets a digital input, or a virtual input via the CMD word, to lock the device. When this input is activated (Low level on digital inputs, high level on virtual inputs), the relay assigned to **[Mains Contactor]** is forced to open, which opens the mains contactor and stops the motor in freewheel.

To restart the motor, deactivate the digital input command and apply a new Run order.

- **[Not Assigned]**: No input assigned.
- **[DI●]** : Digital input DI● assigned.
- **[CD●●]** : Assigned to line channel.

This parameter can be accessed if **[Mains Contactor]** is set to **[R1]** or **[R2]**.

[Device Lock] does not affect the emergency stop switch.

NOTE: Can be use as an external input not link to emergency chain (to lock or) unauthorize the starting procedure or to order a free wheel stop.

Start and Stop : Enhance the motor control

(Is not available for ATS22).

Start profile and Stop profile are set in the **[Simply start]** menu. Additional features can be set :

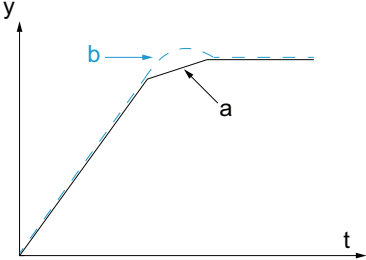
HMI label	Setting	Factory setting
[Torque Limit] <small>TLI</small> 	10...200% of nominal torque or [No]	[No]
<p>Torque limit</p> <p>This parameter:</p> <ul style="list-style-type: none"> • Set the final torque of the torque-controlled acceleration when [Control Mode] it set to [Torque Control]. • Limit the torque reference to avoid regenerative behavior in applications with high inertia. • Can be used for constant starting torque if [Init Starting Torque] = [Torque Limit] and if the application load is compliant. <div style="display: flex; align-items: flex-start;"> <div style="flex: 1;">  </div> <div style="flex: 1; margin-left: 20px;"> <ul style="list-style-type: none"> • y: Motor speed • t: Time (s) • a: No generative mode with appropriate <small>TLI</small> • b: Generative mode without appropriate <small>TLI</small> </div> </div> <p>This parameter can be accessed if [Control Mode] is set to [Torque Control].</p> <p>NOTE: Set the final torque of the torque-controlled acceleration or limit the torque reference to avoid regenerative behavior in applications with high inertia as press, pumpjack or nodding donkey, centrifugal machines.</p>		

Torque / Voltage Control : Enhance the motor control

(Is not available for ATS22).

Expert point of view : Torque control is specified for pumps, fans with belts, circular saws and limits: Jerk when the motor starts, Hammering effect, Sliding effect.

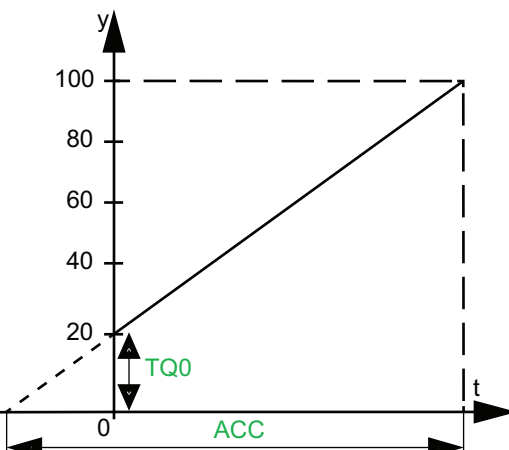
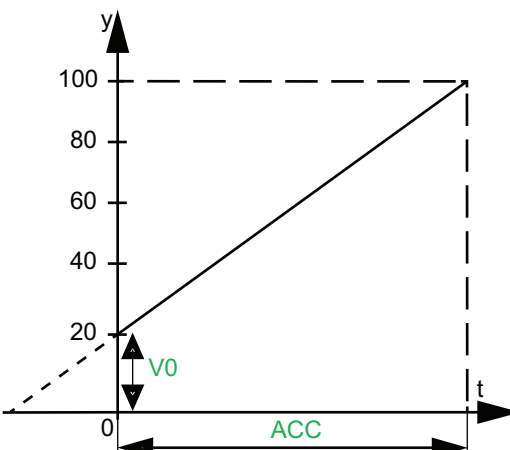
Description	Setting range	Factory setting
[Control Mode] <i>CLP</i>	[Torque Control] <i>TC</i> or [Voltage Control] <i>VC</i>	[Torque Control] <i>TC</i>
<p>Control mode</p> <ul style="list-style-type: none"> [Torque Control]: Activate torque control. [Voltage Control]: Activate voltage control. 		
<p>Acceleration with torque control:</p>  <ul style="list-style-type: none"> y: Reference torque as % of nominal torque t: Time (s) <i>TQ0</i>: Initial starting torque <i>ACC</i>: Acceleration ramp time <p>More information about Initial starting torque and Acceleration ramp time in the ATS430 User Manual, page 13.</p>	<p>Acceleration with voltage control:</p>  <ul style="list-style-type: none"> y: Reference voltage as % of nominal voltage t: Time (s) <i>V0</i>: Initial starting voltage <i>ACC</i>: Acceleration ramp time 	
[Init Starting Voltage] <i>V0</i>	25%...49% of [Mains Voltage] <i>ULN</i>	49%
<p>Initial starting voltage</p> <p>Set [Init Starting Voltage] level between 25% and 49% of [Mains Voltage]. The set value must be high enough to create a torque superior to the resistive torque.</p> <p>This parameter is visible if [Control Mode] is set to [Voltage Control].</p> <p>The function [Boost] can be used to provide a boost at the start to overcome a mechanical hard point. More information about Voltage boost level in the ATS430 User Manual, page 13.</p>		

Voltage Boost : Enhance the motor control



(Is not available for ATS22).

Description	Setting range	Factory setting
[Boost] <i>BST</i>	50%...100% of [Mains Voltage] <i>ULN</i>	50%
<p>Voltage boost level</p> <p>Setting the value of this parameter too high can cause overcurrent and trigger error such as [Overcurrent].</p> <p>NOTE: This function can be used to provide a boost at the start to overcome a mechanical hard point. The voltage boost can be used in torque control and voltage control. The voltage boost function apply a level of the nominal voltage [Mains Voltage] between 50% and 100% for 100 ms.</p> <p>NOTE: Compared to ATS22, [Boost] set a time of the pulse (fixed to 80% of [Mains Voltage]), for ATS430 [Boost] set a percent of [Mains Voltage] with 100ms fixed time.</p>		



Command Channel : Enhance the ATS430 commands

(Was different with ATS22 settings).

HMI label	Setting	Factory setting
[Control Mode] <i>CHCF</i>	—	[Standard Profile] <i>STD</i>
<p>Control mode configuration</p> <ul style="list-style-type: none"> Set [Control Mode] to [Standard Profile] to use the latest evolutions of the embedded Modbus. The [Standard Profile] is based on CIA402. Set [Control Mode] to [I/O profile] to mirror the use of the terminal, by allowing to use 1 bit of command register to activate a function. 		
<h3>⚠ WARNING</h3>		
<p>UNANTICIPATED EQUIPMENT OPERATION</p> <p>Disabling [I/O profile] <i>IO</i> resets the device to the factory settings.</p> <ul style="list-style-type: none"> Verify that restoring the factory settings is compatible with the type of wiring used. <p>Failure to follow these instructions can result in death, serious injury, or equipment damage.</p>		

HMI label	Setting	Factory setting
[Command Switching]  CCS	–	[Cmd channel 1] CD1
<p>Command switching</p> <div style="border: 1px solid black; padding: 10px; text-align: center;"> <p>⚠ WARNING</p> <p>UNANTICIPATED EQUIPMENT OPERATION</p> <p>This parameter can cause unintended movements, for example, inversion of the direction of rotation of the motor, sudden acceleration or stops.</p> <ul style="list-style-type: none"> • Verify that the setting of this parameter does not cause unintended movements. • Verify that the setting of this parameter does not result in unsafe conditions. <p>Failure to follow these instructions can result in death, serious injury, or equipment damage.</p> </div> <p>This parameter sets which channel takes the command of the soft starter.</p> <ul style="list-style-type: none"> • [Cmd channel 1] : Command channel defined via Command channel 1 assign (in this case, switching between [Cmd channel 1] and [Cmd channel 2] is not possible). • [Cmd channel 2] : Command channel defined via Command channel 2 assign (in this case, switching between [Cmd channel 1] and [Cmd channel 2] is not possible). • [DI3] : Command channel switching assigned to digital input DI3, this setting assign also [DI3 assignment] to [Cmd switching] • [DI4] : Command channel switching assigned to digital input DI4, this setting assign also [DI4 assignment] to [Cmd switching] • [Cy••] : Command channel switching assigned to line channel. <p>When assigned to a digital input:</p> <ul style="list-style-type: none"> • [Cmd channel 1] active at low level • [Cmd channel 2] active at high level 		
[Cmd channel 1] CD1	–	[Terminal] TER
<p>Command channel 1 assign</p> <p>This parameter sets the active command channel for [Cmd channel 1].</p> <ul style="list-style-type: none"> • [Terminal]: command with the digital inputs • [HMI]: command with the display terminal • [Embd Mdb]: command with the embedded Modbus 		
[Cmd channel 2]  CD2	–	[Embd Mdb] MDB
<p>Command channel 2 assign</p> <p>This parameter sets the active command channel for [Cmd channel 2].</p> <ul style="list-style-type: none"> • [Terminal]: command with the digital inputs • [HMI]: command with the display terminal • [Embd Mdb]: command with the embedded Modbus 		

HMI label	Setting	Factory setting
[Copy Ch1-Ch2]  COP	—	[No] NO
<p>Copy Ch.1-Ch.2</p> <p>This parameter copies the channel command configuration.</p> <ul style="list-style-type: none"> • [No]: No copy. • [Command]: Copy the command words from channel 1 to channel 2 in [Standard Profile] and in both directions in [I/O profile]. <p>When a remote display terminal is used and a communication interruption is detected with it, the embedded display terminal becomes active.</p> <p>If the transition to HMI command is done with the product in running state, and the parameter [Copy Ch1-Ch2] is set to [Command], the product may continue in running state and the STOP button will only be accessible on the embedded display terminal.</p>		
⚠ WARNING		
<p>LOSS OF CONTROL</p> <p>Verify that in case of communication interruption with the remote display terminal, the STOP button of the embedded display terminal is easily accessible or that an integrated and functioning emergency stop push-button is within reach.</p> <p>Failure to follow these instructions can result in death, serious injury, or equipment damage.</p>		
⚠ WARNING		
<p>UNANTICIPATED EQUIPMENT OPERATION</p> <p>This parameter can cause unintended movements, for example, inversion of the direction of rotation of the motor, sudden acceleration or stops.</p> <ul style="list-style-type: none"> • Verify that the setting of this parameter does not cause unintended movements. • Verify that the setting of this parameter does not result in unsafe conditions. <p>Failure to follow these instructions can result in death, serious injury, or equipment damage.</p>		
<p>NOTE: A command cannot be copied from a channel on terminals.</p>		

HMI label	Setting	Factory setting
[Forced Local Assign]  FLO	–	[Not Assigned] NO
<p>Forced local assignment</p> <p>This parameter forces the local channel set by [Forced Local Chan].</p> <p>[Forced Local Assign] is active when a high level is applied to the set digital input. When the forced local channel is activated, the soft starter is stopped following the type of stop set by [Type of stop] if a Run command is not active on the forced channel and all the parameter write requests coming from fieldbus are rejected.</p> <p>NOTE: [Forced Local] is not compatible with [Control Mode] set to [I/O profile].</p> <p>[Forced Local Assign] is active when a high level is applied to the set digital input.</p> <ul style="list-style-type: none"> • [Not Assigned] : No digital input set • [DI3] : Forced local assignment set to digital input DI3 on high level, this setting assign also [DI3 assignment] to [Forced Local] • [DI4] : Forced local assignment set to digital input DI4 on high level, this setting assign also [DI4 assignment] to [Forced Local] <p>The assigned digital input is set to [Forced Local].</p>		
[Forced Local Chan]  FLOC	–	[Terminal] TER
<p>Forced Local channel assignment</p> <p>This parameter set which local channel is forced at the activation of the digital input set in [Forced Local Chan].</p> <ul style="list-style-type: none"> • [Terminal] : Forced local channel are the digital inputs • [HMI] : Forced local channel is forced on the display terminal <p>This parameter is visible only if [Forced Local Assign] is configured. When a remote display terminal is used and a communication interruption is detected with it, the embedded display terminal becomes active.</p> <p>If the parameter [Forced Local Chan] is set to [Terminal] and the active command channel becomes the HMI at the exit of the forced local mode while the product is in running state, the product stays in this state and the STOP button will only be accessible on the embedded display terminal.</p>		
<p>⚠ WARNING</p>		
<p>LOSS OF CONTROL</p> <p>Verify that in case of communication interruption with the remote display terminal, the STOP button of the embedded display terminal is easily accessible or that an integrated and functioning emergency stop push-button is within reach</p> <p>Failure to follow these instructions can result in death, serious injury, or equipment damage.</p>		
[Time-out forc. local]  FLOT	0.1...30.0 s	10.0 s
<p>Time-out forc. local</p> <p>Timeout to confirm a new channel command after forced local deactivation.</p> <p>This parameter is visible only if [Forced Local Assign] is configured.</p> <p>At exit of forced local, in case of communication interruption, the active channel remains the forced channel until [Time-out forc. local] is expired. Without any new command coming from the channel command, the device will trigger [Mdb Com Interrupt] error.</p>		

This function can be used to set the command channel of the ATS430 (by a fieldbus, embedded modbus, terminal or optional HMI). The different settings manage the behavior of the multiplexer of the different channels and manage the switching from one channel to another or forced local (orders by the wiring terminal) mode.

Compared to ATS22, the ATS430 provides more advanced communication features.

[I/O profile] is not consistent with ATS22 serial link management. The original PLC program may be update and adapted to manage the substitution of ATS22 versus ATS430 Soft starter.

NOTE: To command the soft starter by the communication channel, **STOP** must be wired to +24V. (Stop active).

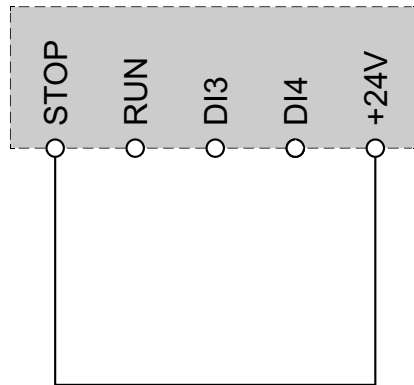

Command word

Bit	ATS22		ATS430	
	Function	Comment	Function	Comment
Bit 0	RUN/STOP	Write "1" (On) to RUN Write "0" (oFF) to STOP, in configured stop (DEC parameter)	Switch	Bit at 1 -> On
Bit 1	Reserved		Enable / Disable voltage	Bit at 1 -> Enable
Bit 2			Quick Stop	Bit at 0-> Activate
Bit 3	Trip reset	Write "1" to reset	Operation Run command	Bit at 1 -> Enable
Bit 4	Reserved		Reserved	
Bit 5				
Bit 6				
Bit 7			Error reset request	Active on rising edge
Bit 8			Halt command	Bit at 0 ->Request not sent Bit at 1 -> Stop following [Type of stop]
Bit 9			Reserved	
Bit 10	Freewheel stop	Write "1" to set freewheel deceleration, linked with bit 0		
Bit 11	2nd set of parameters	Write "1" to enable second set of parameters	Manufacturer specific assignable	
Bit 12	Reserved			
Bit 13				
Bit 14			Decelerated stop order	Bit at 1-> Activate NOTE: The Bit can be set to an other function (factory setting).
Bit 15	Forced local command	Write "1" (On) forces local command	Manufacturer specific assignable	

Input/Output Assignment

(Was different with ATS22 settings).

Access path: [Input/Output]

Description	Setting range	Factory setting
[DI3 assignment] L3A [DI4 assignment] L4A	–	[No] NO [No] NO
<p>DI3 assignment & DI4 assignment</p> <p>Those parameters assign a function to the digital inputs DI3 and DI4.</p> <p>Only one function can be assigned to [DI3 assignment] or [DI4 assignment] at any moment. If you assign a new function to an already assigned digital input, the previous function assigned to this digital input will be deactivated.</p> <p>Unless specified otherwise, the following assignments are active when a high level is applied.</p> <ul style="list-style-type: none"> • [No]: Digital input not assigned. • [Fault Reset]: Resets the device to clear a detected error after removing its cause. • [External Error]: Allows the device to trigger an external user error (level, pressure, ...). The external error can trigger on a high or low level, set by [Ext Error Condition]. Automatic assignment: [Ext Error assign] set to digital input. • [Cmd switching] : Sets the active command channel ([Cmd channel 1] active at low level or [Cmd channel 2] active at high level). This function can be assigned only via the parameter [Command Switching] in the menu [Complete settings] → [Command channel]. This function cannot be assigned via the menu [Input/Output]. If [Command Switching] is assigned to a digital input, it is necessary to remove first this assignation via the parameter before assigning the digital input to a new function. • [Forced Local]: Forces the local channel set by [Forced Local Chan]. Automatic assignment: [Forced Local Assign] set to digital input. • [Disable Error Detect]: Inhibits error detection. The soft starter records the detected errors but doesn't stop running. Automatic assignment: [Disable Error Detect] set to digital input. • [Device Lock]: Forces open the relay assigned to [Mains Contactor]. Active on low level. Automatic assignment: [Device Lock] set to digital input. • [Preheating]: Starts the preheating. Automatic assignment: [Preheating Assign] set to digital input. • [Boost]: Starts the preheating. Automatic assignment: [Boost Assign] set to digital input. 		

Step 17: Check ATS430 software add-on functionalities or monitoring versus ATS22

ATS430 allows to define more functionalities than ATS22 :

- Analogic output to display a signal on analogic screen in 0-10V or 0/4-20mA with scaling management.
- The R2 relay to inform the PLC or electric sequence of the ATS430 states.

Step 18: Start and monitor application

Due to the 2 phases control on ATS430, the performance of the motor starting may be different compared to ATS22, in case of using the same settings.

If the starting is a strong criteria of the application, the settings of **[Current Limit]** and **[Init Starting Torque]** of the ATS430 may need to be adjusted/increased. In this case the circuit breaker magnetic protection may need to be adjusted.

Step 19: HMI monitoring and Diagnostic

For more information, refer to the ATS430 User Manual, page 13.

Additional Support

Electronic product data sheet

Scan the QR code in front of the soft starter to get the product data sheet.

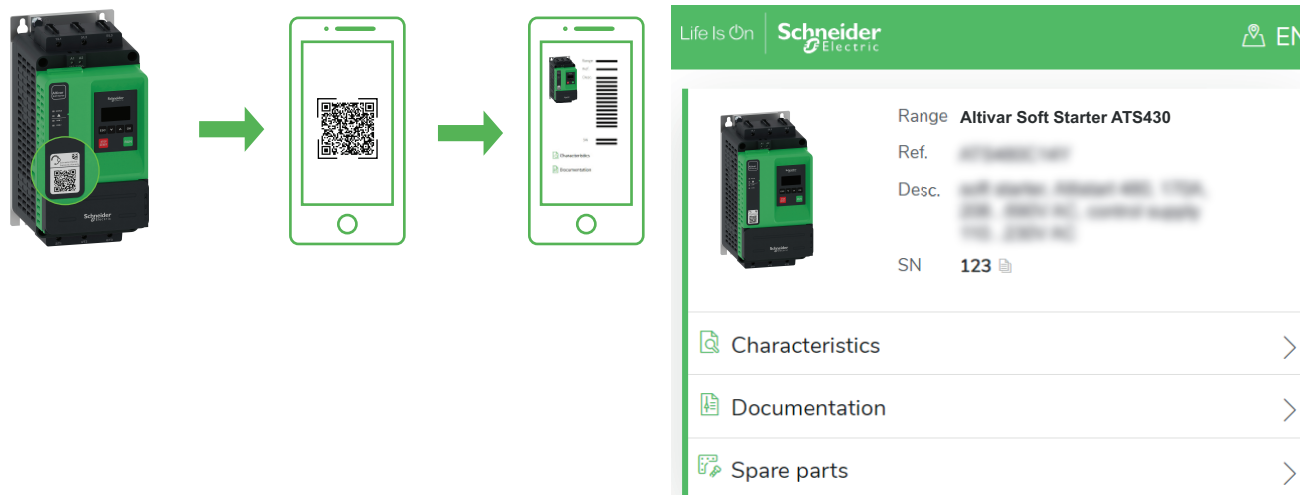

Scanning the QR Code gives you access to :

- Product ID Card : Product range, Reference, short description and a Serial Number (Use the serial number to retrieve the product's manufacturing date).
About the Serial Number, refer to Manufacturing Date, page 59.
- The product characteristics : Main characteristics, environment, packing units, sustainability...
- Documentation : Technical Guidance at Glance (Presentation, Dimensions, Mounting, Wiring, Commissioning...) and Product Documentation (User guide, Instructions sheets, Certificates, How To videos...)
- Spare parts for your product

Manufacturing Date

Use the serial number on the nameplate of the soft starter to retrieve its manufacturing date.

The four digits before the 2 characters of the serial number provide respectively the year and the week of manufacture.

In the example below **HL2422110100130** the manufacturing date is year 2024, week 22.



HL2422110100130

Customer Care Center

For additional support, you can contact our Customer Care Center on: www.se.com/CCC

Glossary

D

Display terminal:

The Display Terminal is a local control unit plugged on the soft starter.

E

Error :

Discrepancy between a detected (computed, measured, or signaled) value or condition and the specified or theoretically correct value or condition.

F

Factory setting:

Machine status in factory settings when the product was shipped.

Fault Reset:

A function used to restore the soft starter to an operational state after a detected error is cleared by removing the cause of the error so that the error is no longer active.

Fault:

Fault is an operating state. If the monitoring functions detect an error, a transition to this operating state is triggered, depending on the error class. A "Fault reset" is required to exit this operating state after the cause of the detected error has been removed.

M

Monitoring function:

Monitoring functions acquire a value continuously or cyclically (for example, by measuring) in order to check whether it is within permissible limits. Monitoring functions are used for error detection.

N

NC contact:

Normally Closed contact

NO contact:

Normally Open contact

P

Parameter:

Device data and values that can be read and set (to a certain extent) by the user.

PTC:

Positive Temperature Coefficient. PTC thermistor probes integrated in the motor or application to measure its temperature

W

Warning:

If the term is used outside the context of safety instructions, a warning alerts to a potential error that was detected by a monitoring function. A warning does not cause a transition of the operating state.

Schneider Electric
35 rue Joseph Monier
92500 Rueil Malmaison
France

+ 33 (0) 1 41 29 70 00

www.se.com

As standards, specifications, and design change from time to time, please ask for confirmation of the information given in this publication.

© 2025 Schneider Electric. All rights reserved.

BQT74917.01