

Panel cut-out / Découpe du panneau / Montageausschnitt / Plano de soporte / Sezione del pannello / 面板截图

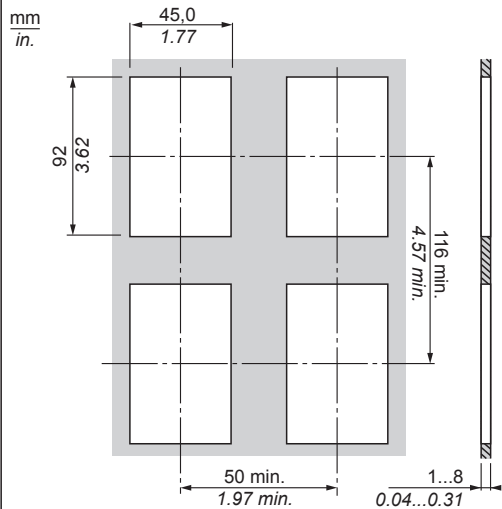

Installing multiple controllers horizontally (no waterproof)
 Installation de plusieurs contrôleurs à l'horizontale (non étanche)
 Installieren mehrerer Steuerungen horizontal (nicht wasserdicht)
 Instalación horizontal de varios controladores (no impermeable)
 Installazione orizzontale di controller multipli (non a tenuta)
 水平安装多个控制器 (无防水功能)

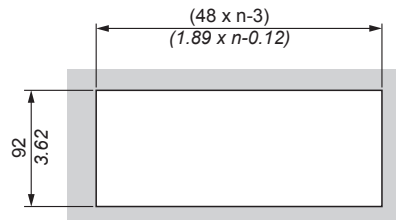

Wiring / Cablage / Verdrahtung / Cableado / Cablaggio / 接线

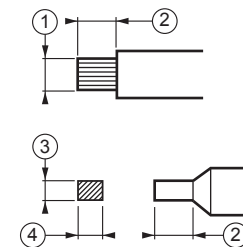

- ① 0.1 mm²...1.25 mm²
AWG28...AWG16
- ② 5...6 mm
0.20...0.24 in
- ③ 2 x 1.5 mm max.
- ④ 0.08 x 0.06 in max.

- en** Electrical equipment should be installed, operated, serviced, and maintained only by qualified personnel. No responsibility is assumed by Schneider Electric for any consequences arising out of the use of this material.
- fr** Les équipements électriques doivent être installés, exploités et entretenus par un personnel qualifié. Schneider Electric n'assume aucune responsabilité des conséquences éventuelles découlant de l'utilisation de cette documentation.
- de** Elektrische Geräte dürfen nur von Fachpersonal installiert, betrieben, gewartet und instand gesetzt werden. Schneider Electric haftet nicht für Schäden, die aufgrund der Verwendung dieses Materials entstehen.
- es** Sólo el personal de servicio cualificado podrá instalar, utilizar, reparar y mantener el equipo eléctrico. Schneider Electric no asume las responsabilidades que pudieran surgir como consecuencia de la utilización de este material.
- it** Le apparecchiature elettriche devono essere installate, usate e riparate solo da personale qualificato. Schneider Electric non assume nessuna responsabilità per qualunque conseguenza derivante dall'uso di questo materiale.
- zh** 电气设备的安装、操作、维修和维护工作仅限于合格人员执行。对于使用本资料所引发的任何后果, Schneider Electric 概不负责。

⚠ DANGER / DANGER / GEFAHR / PELIGRO / PERICOLO / 危险

<p>HAZARD OF ELECTRIC SHOCK, EXPLOSION OR ARC FLASH</p> <ul style="list-style-type: none"> Remove all power from the Controller. Unplug the power cable from both the Controller and the power supply. Always use a properly rated voltage sensing device to confirm power is off. Use only the specified voltage when operating the Controller. <p>Failure to follow these instructions will result in death or serious injury.</p>	<p>RISQUE D'ELECTROCUTION, D'EXPLOSION OU D'ARC ELECTRIQUE</p> <ul style="list-style-type: none"> Retirez toute alimentation du contrôleur. Débranchez le câble d'alimentation du contrôleur et de l'alimentation. Utilisez toujours un appareil adapté pour vérifier que l'alimentation est coupée. Utilisez uniquement la tension indiquée lors du fonctionnement du contrôleur. <p>Le non-respect de ces instructions provoquera la mort ou des blessures graves.</p>	<p>STROMSCHLAG-, EXPLOSIONS- ODER LICHTBOGENGEFAHR</p> <ul style="list-style-type: none"> Trennen Sie die Steuerung von der Stromversorgung. Ziehen Sie das Stromkabel vom Controller ab, und ziehen Sie es aus der Netzsteckdose. Verwenden Sie immer einen geeigneten Spannungsprüfer, um auf Spannungsfreiheit zu überprüfen. Verwenden Sie bei der Inbetriebnahme der Steuerung nur die vorgegebene Spannung. <p>Die Nichtbeachtung dieser Anweisungen führt zu Tod oder schwerer Körperverletzung.</p>
<p>RIESGO DE ELECTROCUCIÓN, EXPLOSIÓN O ARCO ELÉCTRICO</p> <ul style="list-style-type: none"> Retire cualquier fuente de alimentación del controlador. Desconecte el cable de alimentación del controlador y de la fuente de alimentación. Utilice siempre un dispositivo de medición de tensión adecuado para confirmar que no haya alimentación. Utilice únicamente la tensión especificada cuando maneje el controlador. <p>Si no se siguen estas instrucciones provocará lesiones graves o incluso la muerte.</p>	<p>RISCHIO DI SCOSSA ELETTRICA, DI ESPLOSIONE O DI OFTALMIA DA FLASH</p> <ul style="list-style-type: none"> Mettere il Controller fuori tensione. Staccare il cavo di alimentazione sia sul Controller sia sull'alimentatore. Utilizzare sempre un volmetro per confermare che l'alimentazione sia esclusa. Utilizzare solo la tensione nominale specificata per il funzionamento del Controller. <p>Il mancato rispetto di queste istruzioni provocherà morte o gravi infortuni.</p>	<p>存在电击、爆炸或电弧闪烁危险</p> <ul style="list-style-type: none"> 断开控制器的所有电源。 从控制器和电源上拔下电源电缆。 始终使用合适的额定电压感应设备, 以确认电源已关闭。 在操作控制器时, 只使用指定电压。 <p>不按照上述规定操作会导致严重的人员伤亡。</p>

Wiring / Cablage /
Verdrahtung / Cableado /
Cablaggio / 接线

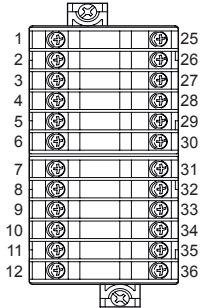

REG 96PUN2RHU,
REG 96PUN2LRHU,
REG 96PUN2LJHU

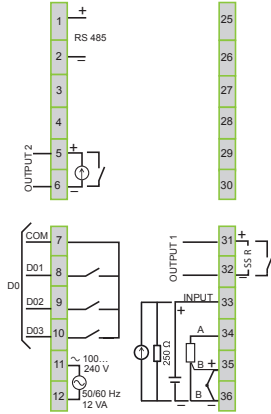

REG 96PUN2RLU,
REG 96PUN2LRLU,
REG 96PUN2LJLU

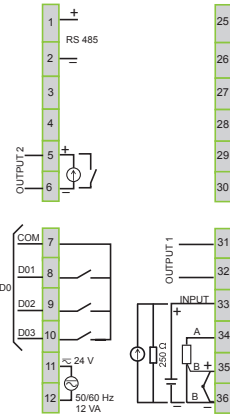

REG 96PUN1RHU,
REG 96PUN1LHU,
REG 96PUN1JHU

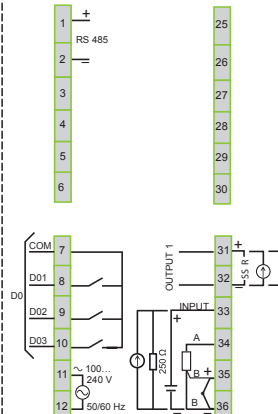

REG 96PUN1RLU,
REG 96PUN1LLU,
REG 96PUN1JLU

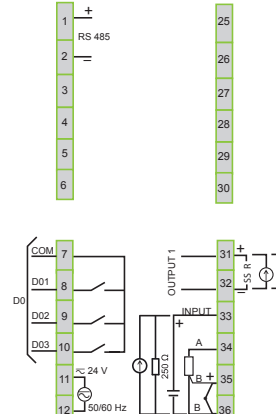

REG 96PUNL1RHU,
REG 96PUNL1LHU

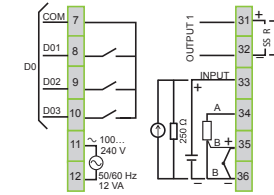

en Temperature Controllers

Part number	Power supply	Input	Output 1	Output 2	Modbus	Alarm
REG 96PUN1RHU	100-240VAC	Universal	Relay	-	X	3
REG 96PUNL1RHU			Relay	-	-	3
REG 96PUN1LHU			SSR	-	X	3
REG 96PUNL1LHU			SSR	-	-	3
REG 96PUN1JHU			4-20mA	-	X	3
REG 96PUN2RHU			Relay	Relay	X	3
REG 96PUN2LRHU	24VDC/VAC	Universal	SSR	Relay	X	3
REG 96PUN2LJHU			SSR	4-20mA	X	3
REG 96PUN1RLU			Relay	-	X	3
REG 96PUN1LLU			SSR	-	X	3
REG 96PUN1JLU			4-20mA	-	X	3
REG 96PUN2RLU			Relay	Relay	X	3
REG 96PUN2LRLU	SSR	Relay	X	3		
REG 96PUN2LJLU	SSR	4-20mA	X	3		
REG 96PCOV	Terminal block cover					

Connecting to a programmable controller / Raccordement à un automate programmable /
Anschließen an eine programmierbare Steuerung / Conexión a un controlador programable /
Connessione a un controller programmabile / 连接到可编程控制器

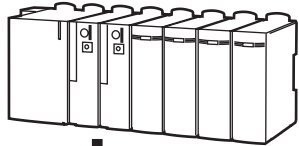

Programmable controller / Automate programmable /
Programmierbare Steuerung / Controlador programable /
Controller programmabile / 可编程控制器

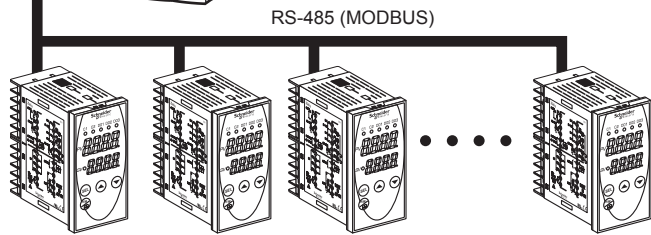

Refer to EIO0000001299 User Guide for setting / Consultez le Manuel utilisateur EIO0000001302 pour la configuration /
Vgl. EIO0000001305 Benutzerhandbuch für die Einstellung / Consulte el manual del usuario EIO0000001334 para obtener información
sobre los ajustes / Per le impostazioni fare riferimento alla Guida utente EIO0000001331 / 有关设置, 请参阅《EIO0000001337 用户指南》

Connecting to a PC / Raccordement à un PC / Anschließen an einen PC /
Conexión a un PC / Connessione a un PC / 连接到 PC

