

# SpaceLogic Room Controllers

SER8350/SE8350 Application Guide  
Fan Coil Unit (FCU)  
Firmware release version 2.6



## TABLE OF CONTENTS

OVERVIEW.....	3
SER8350 3-SPEED FAN.....	10
SER8350 ECM FAN .....	29
SE8350 3-SPEED FAN .....	46
SE8350 ECM FAN.....	65
SE8350 MIXED VOLTAGE.....	85
APPENDIX A - VC3000 RELAY PACK WIRING .....	91
APPENDIX B - OPTIONAL NETWORK SET-UP .....	92
APPENDIX C - WIRELESS SENSORS .....	92
APPENDIX D - SCHEMATIC OF CONTROLLERS OCCUPANCY SEQUENCE OF OPERATION WITHOUT DOOR SENSOR .....	93
APPENDIX E - DEPLOYMENT.....	94

# Overview

## SER8350 AND VC3000 LINE-VOLTAGE FAN COIL TERMINAL EQUIPMENT CONTROLLERS AND RELAY PACKS

This new cost-effective solution for upgrading line-voltage fan coil unit thermostats requires only two components; the SER8350 Terminal Equipment Controller and the VC3000 Relay Pack. This solution allows existing line voltage wiring between the fan coil unit and temperature controller to be re-used, thereby reducing overall costs and installation time.

The VC3000 Relay Pack features an onboard universal voltage power supply and line-voltage relays which directly drive fractional horsepower fan motors and valves. This eliminates the need to install and wire costly pilot relays and transformers. The Relay Pack is not required for the SE8350 models.

Commercial and Hospitality Interface (Local Override and Degrees C/F Selection)						
	Part Number	Description	Humidity	PIR Sensor	ZigBee on-board	Communication 0
	SER8350A0BXX	BACnet® fan coil terminal equipment controller	Yes	No	No. See note below*	BACnet MS/TP or Modbus RTU
	SER8350A5BXX	BACnet® fan coil terminal equipment controller	Yes	Yes	No. See note below*	BACnet MS/TP or Modbus RTU
	SER8350A5BXXP	BACnet® fan coil terminal equipment controller	Yes	Yes	Yes	BACnet MS/TP or Modbus RTU

\*Note: ZigBee Pro plug-in module is available

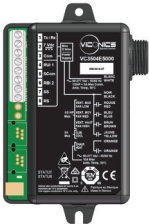
Transformer Relay Packs for Fan Coil Units	
Part Number	Description
 VC3500E5000	Transformer relay pack, 3 fan speed and 2 valve relay outputs
VC3504E5000	Transformer relay pack, 3 fan speed and 2 valve relay outputs, 4 inputs
VC3514E5000	Transformer relay pack, 3 fan speed and 2 valve relay outputs, 4 inputs, 1 occupancy output
VC3400E5000	Transformer relay pack, 3 fan speed and 1 valve relay outputs, 1 smart Vdc output
VC3404E5000	Transformer relay pack, 3 fan speed and 1 valve relay outputs, 1 smart Vdc output, 4 inputs
VC3300E5000	Transformer relay pack, 3 fan speed relay outputs

## SER8350 TERMINAL IDENTIFICATION AND FUNCTION

Terminal Identification	All SER8350 Terminal Equipment Controller
Terminal 4	Tx / Rx Communication
Terminal 5	Power Hot 7 Vdc
Terminal 6	Power Common
Terminal 12	ECM 0-10 Vdc output
Terminal 13	BACnet +
Terminal 14	BACnet -
Terminal 16	BI 1 ( Configurable )
Terminal 17	BI 2 ( Configurable )
Terminal 18	Scm

**NOTE:** never use any terminal on Room Controller not mentioned in above table.

COMMUNICATION WIRING TO VC3000 RELAY PACK

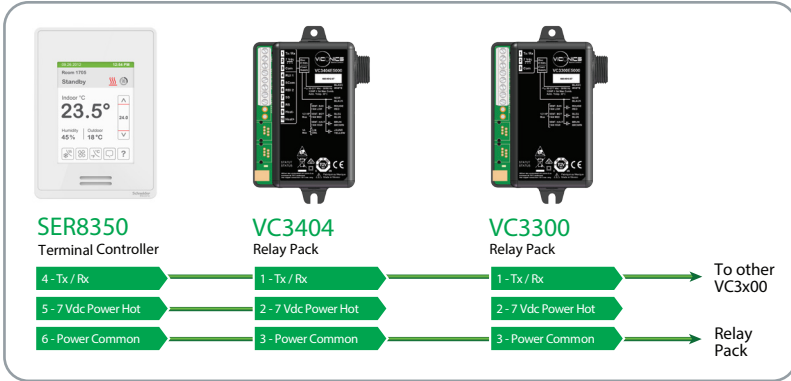

Only **ONE** Relay Pack with remote monitoring inputs (VC3404, VC3504 or VC3514) can be used for a single SER8350 Room Controller. All other Relay Packs must be **without** remote monitoring inputs (VC3300, VC3400 or VC3500).

A maximum of 10 Relay Packs can be used for a single SER8350 Room Controller.

The Relay Packs can be arranged in any order.

From SER8350 to the first VC3000 Relay Pack:

- Uses existing or new field wires
- A minimum of 3 wires are required
- Solid or Stranded, Shield is not necessary
- Distance between the two units must not exceed 15 m (49 ft)
- Wire gauge depends on available distance:
  - ≤ 10 m (33 ft): AWG 16-18 (1.31 - 0.823 mm<sup>2</sup>)
  - > 10 m (33 ft): AWG 16 (1.31 mm<sup>2</sup>)

From the first VC3000 Relay Pack to all other VC3000 Relay Packs:

- Uses existing or new field wires
- 2 required wires AWG 16-18 (1.31 - 0.823 mm<sup>2</sup>):
  - Tx/Rx (1)
  - Power Common (3)
- Solid or Stranded, Shield is not necessary

BACnet® Communication Shielded Wiring (if required)



• **NOTE:** See SER8350 BACnet® integration manual for more details

NOTE

- Only one VC3404 , VC3504 or VC3514 Relay Pack with remote monitoring inputs can be used for a single SER8350 Room Controller.

Network Wiring Topology

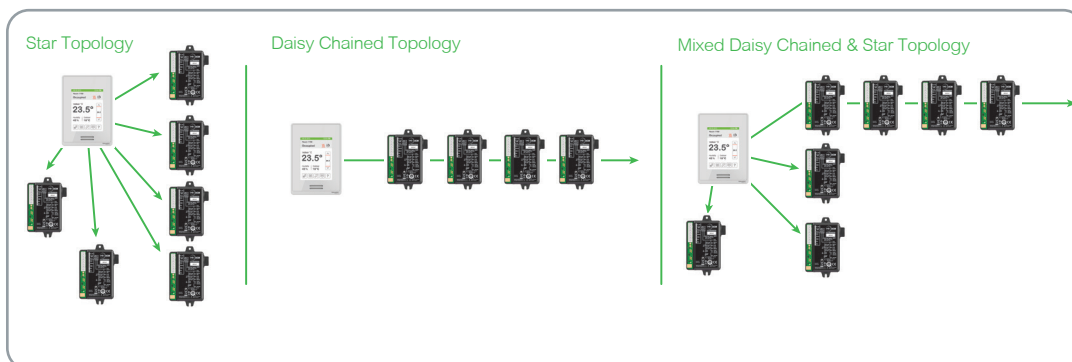

## SE8350 LOW-VOLTAGE 24 VAC FAN COIL TERMINAL EQUIPMENT CONTROLLERS

This new cost-effective solution for upgrading low-voltage fan coil unit thermostats requires only the SE8350 Terminal Equipment Controller.

The SE8350 Terminal Equipment Controller can also be used along with a VC2300 Relay Pack for mixed-voltage solutions, when control of both line-voltage and low-voltage end devices is required.

Commercial and Hospitality Interface (Local Override and Degrees C/F Selection)						
	Part Number	Description	Humidity	PIR Sensor	ZigBee on-board	Communication
	SE8350U0BXX	BACnet® fan coil terminal equipment controller	Yes	No	No. See note below*	BACnet MS/TP or Modbus RTU
	SE8350U5BXX	BACnet® fan coil terminal equipment controller	Yes	Yes	No. See note below*	BACnet MS/TP or Modbus RTU
	SE8350U5BXXP	BACnet® fan coil terminal equipment controller	Yes	Yes	Yes	BACnet MS/TP or Modbus RTU

\*Note: ZigBee Pro plug-in module is available

Mixed-voltage Relay Packs for SE8350		
	Part Number	Description
	VC2300E5000	3 on/off outputs, 220/240 VAC 3 speed

## SE8350 TERMINAL IDENTIFICATION AND FUNCTION

## Terminal identification for 3-Speed Fan System

Fan Type - 3-Speed				
Control Type	On/Off	Floating	Analog	
1- BO1	Not used	Not used	Not used	
2- BO2	Fan-L	Fan-L	Fan-L	
3- BO3	Fan-M	Fan-M	Fan-M	
4- BO4	Fan-H	Fan-H	Fan-H	
5- RC / 24 V~ Hot	24 V~ Hot	24 V~ Hot	24 V~ Hot	
6- C / 24 V~ Com	24 V~ Com	24 V~ Com	24 V~ Com	
7- RH	Aux Heat	Aux Heat	Aux Heat	
8- BO8	Aux Heat	Aux Heat	Aux Heat	
9- UO9	Normally Close Cool Valve	Close Cool Valve	Not used	
10- UO10	Normally Close Heat Valve	Close Heat Valve	Not used	
11- UO11	Normally Open Cool Valve	Open Cool Valve	Analog Heat Valve	Analog Cool Valve *
12- UO12	Normally Open Heat Valve	Open Heat Valve	Analog Cool Valve	Analog Heat Valve **
13- RS485 +	BACnet MS/TP or Modbus (+)			
14- RS485 -	BACnet MS/TP or Modbus (-)			
15- RS485 Ref	BACnet MS/TP or Modbus (Ref) (do not wire shield to this terminal)			
16- UI16	UI16 Function			
17- UI17	UI17 Function			
18- Scom	Common			
19- UI19	UI19 Function			
20- UI20	Remote Room Sensor			
21- Scom	Common			
22- UI22	Remote Supply Sensor			
23- UI23	Not used			
24- UI24	Not used			

**NOTE:**

The Analog control terminations are reversed when used in a 4 pipe mixed application (one analog valve and one On/Off or Floating valve):

\* : The "Analog Cool Valve" output moves to terminal UO11 when:

- "No. of pipes" is set to 4
- "Ctrl. type out1" is set to "0-10V DA" or "0-10V RA"
- "Ctrl. type out2" is set to "On/Off" or "Floating"

\*\* : The "Analog Heat Valve" output moves to terminal UO12 when:

- "No. of pipes" is set to 4
- "Ctrl. type out1" is set to "On/Off" or "Floating"
- "Ctrl. type out2" is set to "0-10V DA" or "0-10V RA"

## Terminal identification for ECM Fan System

Fan Type - ECM				
Control Type	On/Off	Floating	Analog	
1- BO1	Normally Close Heat Valve	Close Heat valve	Not used	
2- BO2	Not used	Not used	Not used	
3- BO3	Not used	Not used	Not used	
4- BO4	ECM Fan Start	ECM Fan Start	ECM Fan Start	
5- RC / 24 V~ Hot	24 V~ Hot	24 V~ Hot	24 V~ Hot	
6- C / 24 V~ Com	24 V~ Com	24 V~ Com	24 V~ Com	
7- RH	Aux Heat	Aux Heat	Aux Heat	
8- BO8	Aux Heat	Aux Heat	Aux Heat	
9- UO9	Normally Close Cool Valve	Close Cool Valve	Not used	
10- UO10	Analog ECM Fan	Analog ECM Fan	Analog ECM Fan	
11- UO11	Normally Open Cool Valve	Open Cool Valve	Analog Heat valve	Analog Cool Valve *
12- UO12	Normally Open Heat Valve	Open Heat Valve	Analog Cool Valve	Analog Heat Valve **
13- RS485 +	BACnet MS/TP or Modbus (+)			
14- RS485 -	BACnet MS/TP or Modbus (-)			
15- RS485 Ref	BACnet MS/TP or Modbus (Ref) (do not wire shield to this terminal)			
16- UI16	UI16 Function			
17- UI17	UI17 Function			
18- Scom	Common			
19- UI19	UI19 Function			
20- UI20	Remote Room Sensor			
21- Scom	Common			
22- UI22	Remote Supply Sensor			
23- UI23	Not used			
24- UI24	Not used			

**NOTE:**

The Analog control terminations are reversed when used in a 4 pipe mixed application (one analog valve and one On/Off or Floating valve):

\* : The "Analog Cool Valve" output moves to terminal UO11 when:

- "No. of pipes" is set to 4
- "Ctrl. type out1" is set to "0-10V DA" or "0-10V RA"
- "Ctrl. type out2" is set to "On/Off" or "Floating"



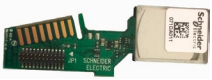

\*\* : The "Analog Heat Valve" output moves to terminal UO12 when:

- "No. of pipes" is set to 4
- "Ctrl. type out1" is set to "On/Off" or "Floating"
- "Ctrl. type out2" is set to "0-10V DA" or "0-10V RA"

## SER8350/SE8350 WIRELESS MODULES AND ACCESORIES

Wireless Communication Modules		
	Part Number	Description
	VCM8000V5045P* Release 24	ZigBee Pro extended profile retrofit communication module.
	VCM8001V5045*	CO2 detection sensor retrofit module.

\* **Note:** Only one of the two modules can be plugged in at one time.

Wireless Accessories		
	Part Number	Description
	SED-CO2-G-5045	Wireless CO2 sensor with room temperature and humidity
	SED-TRH-G-5045	Wireless sensor with room temperature and humidity
	SED-MTH-G-5045	Wireless motion/temperature/humidity sensor
	SED-WDC-G-5045	Wireless window/door sensor
	SED-WLS-G-5045	Wireless water leakage sensor

\* **Note:** Requires embedded ZigBee or a VCM8000V5045P.

**SpaceLogic  
SER8350 3-Speed  
Fan**

## SER8350

## 1, 2 OR 3-SPEED FAN APPLICATIONS

System	Fan	Cooling	Heating	Other
4 pipes	3 Speed	2 positions valve	2 positions valve	Motion detect
2 pipes	3 Speed	2 positions valve	Heating SSR	Dehumidification
2 pipes	3 Speed	2 positions valve	Changeover sensor	Motion detect
2 pipes	3 Speed	2 positions valve	Changeover sensor	Fresh air damper
4 pipes	Two 3 speed	2 positions valve	2 positions valve	Two VC3000 relay packs
2 pipes	3 Speed	2 positions valve	Changeover sensor	Window sensor
4 pipes	3 Speed	2 positions valve	2 positions valve	Door and motion detect

See Appendix A for VC3000 relay pack wiring.

SER8350 WITH VC3500 RELAY: HEATING/COOLING 4-PIPE FAN COIL UNIT WITH 3-SPEED FAN AND 2-POSITION VALVES

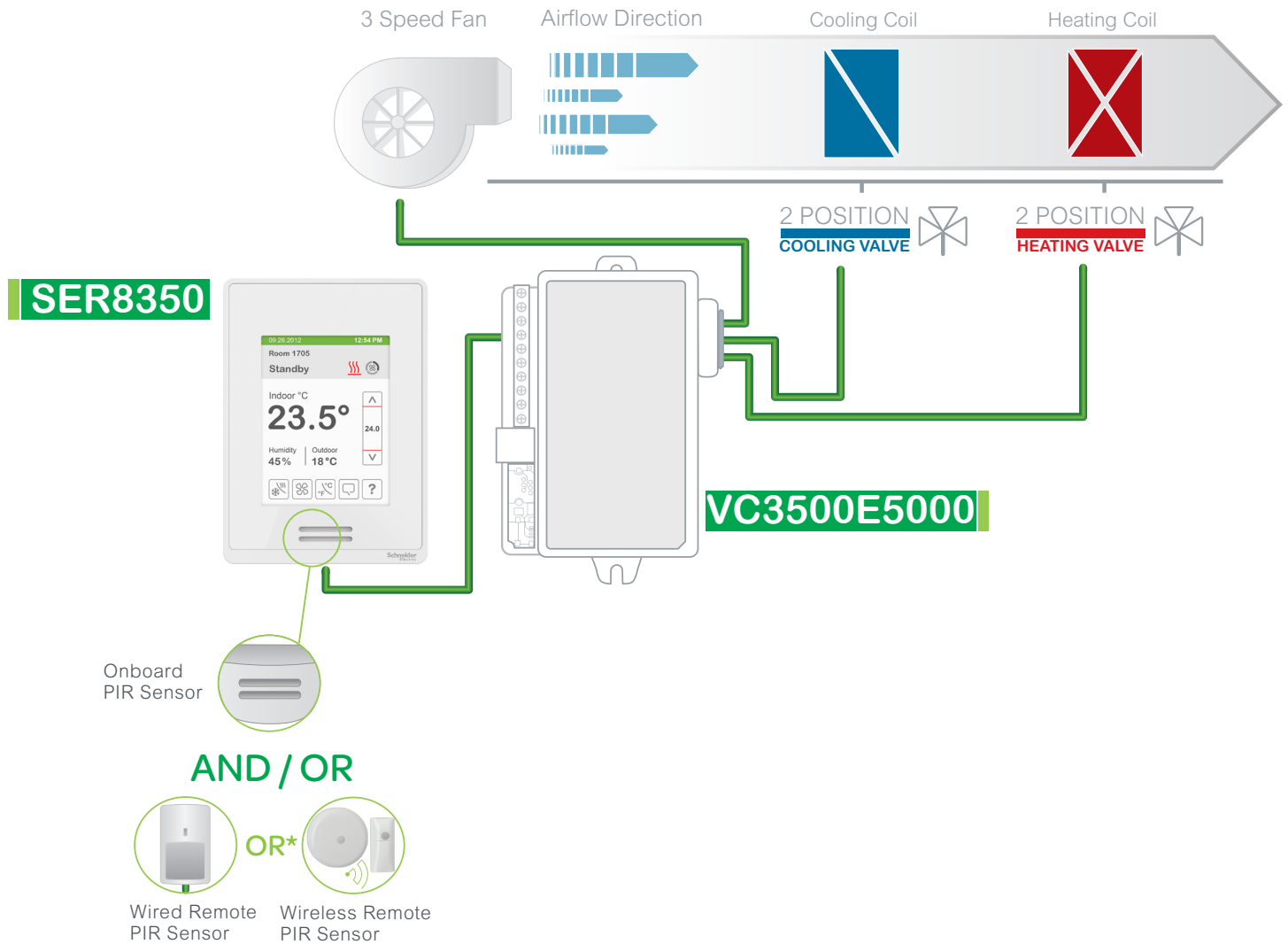

Configuration Parameter Name	Configuration Settings
Fan type	3 speed
Fan menu	L-M-H-A
Fan cont. heat.	On
BI1 config	Motion NO or Motion NC (remote PIR sensor only)
BI2 config	Door Dry
Pulsed heating	Off
No. of pipes	4
Operation sequence	Cool/Heat

\* Wired remote sensor cannot be used at the same time as wireless remote sensor(s).

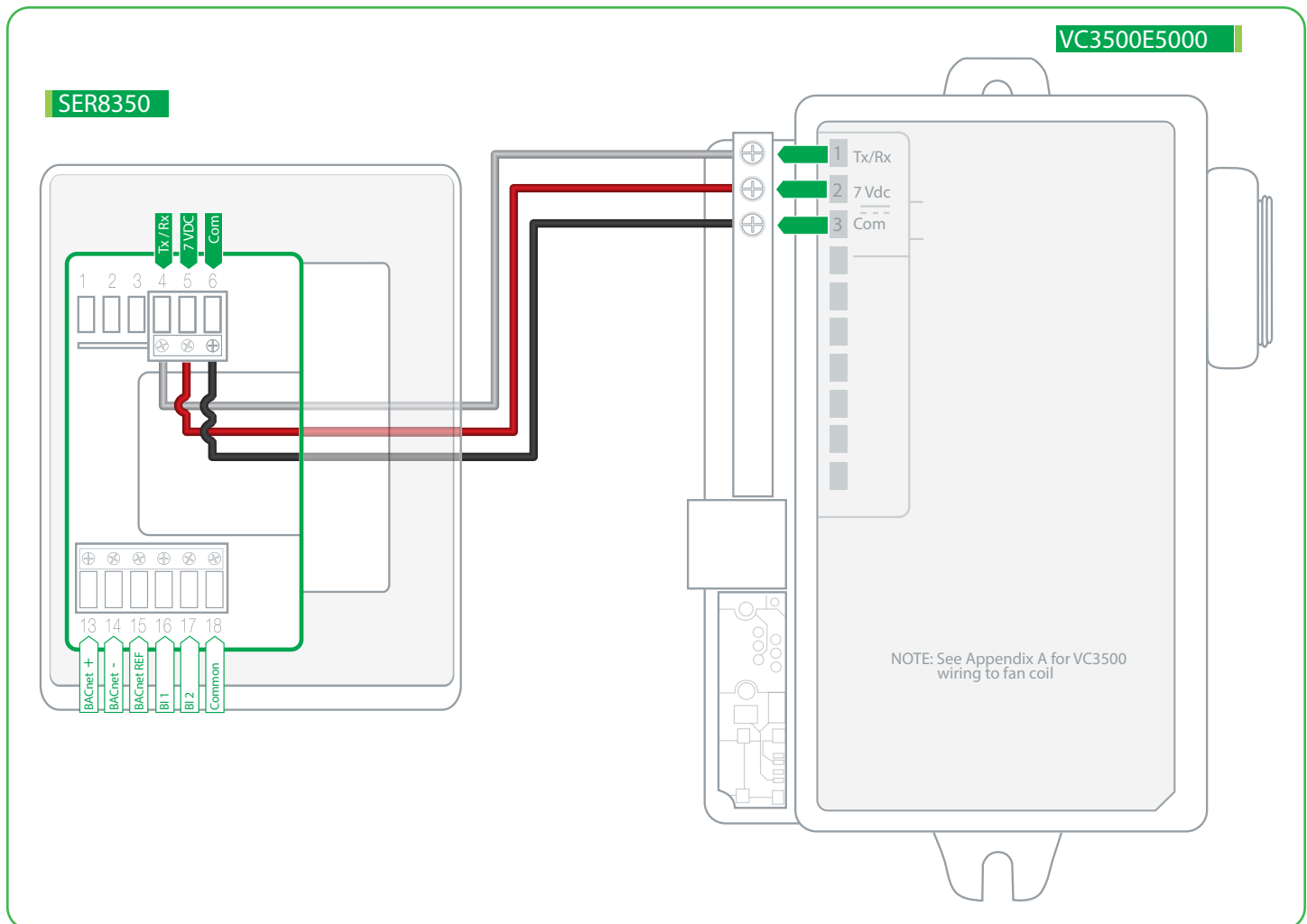

## Sequence of Operation and Wiring

### Occupied Mode

Setpoints revert to those defined by occupied cooling and heating.

### Stand-by Mode (only available when PIR motion detector sensor is used)

Setpoints revert to those defined by stand-by cooling and heating.

### Unoccupied Mode

Setpoints revert to those defined by unoccupied heating and cooling.

### Occupied Override Mode

System reverts to occupied mode for duration determined by "ToccTime" parameter.

### On Call for Cool

Cooling valve opens to maintain room temperature. Heating valve closed.

### On Call for Heat

Heating valve opens to maintain room temperature. Cooling valve closed.

### Wireless Door Switch and Motion

Wireless door switch automatically toggles occupancy to standby. Motion will switch to occupied as long as the door stays closed

## Options

- Wireless adapter modules are available. (see Appendix B for network wiring).
- Can be configured for 2-pipe systems (without changeover).
- Binary inputs can be configured to control occupancy via door or window contact, remote motion sensor, or remote night setback.

## 3 Speed Fan Operation

### System Off

Brown, blue and red wires are not energized

### System On: (Fan modes)

- Low: red wire is energized
- Med: blue wire is energized
- High: brown wire is energized.
- Auto: When there is no demand, brown, blue and red wires are not energized. On demand, system will automatically switch "on" low (red), medium (blue) or high (brown) speed.

SER8350 WITH VC3404 RELAY: COOLING AND ELECTRIC HEAT 2-PIPE FAN COIL UNIT WITH 3-SPEED FAN, DEHUMIDIFICATION AND 2-POSITION VALVES

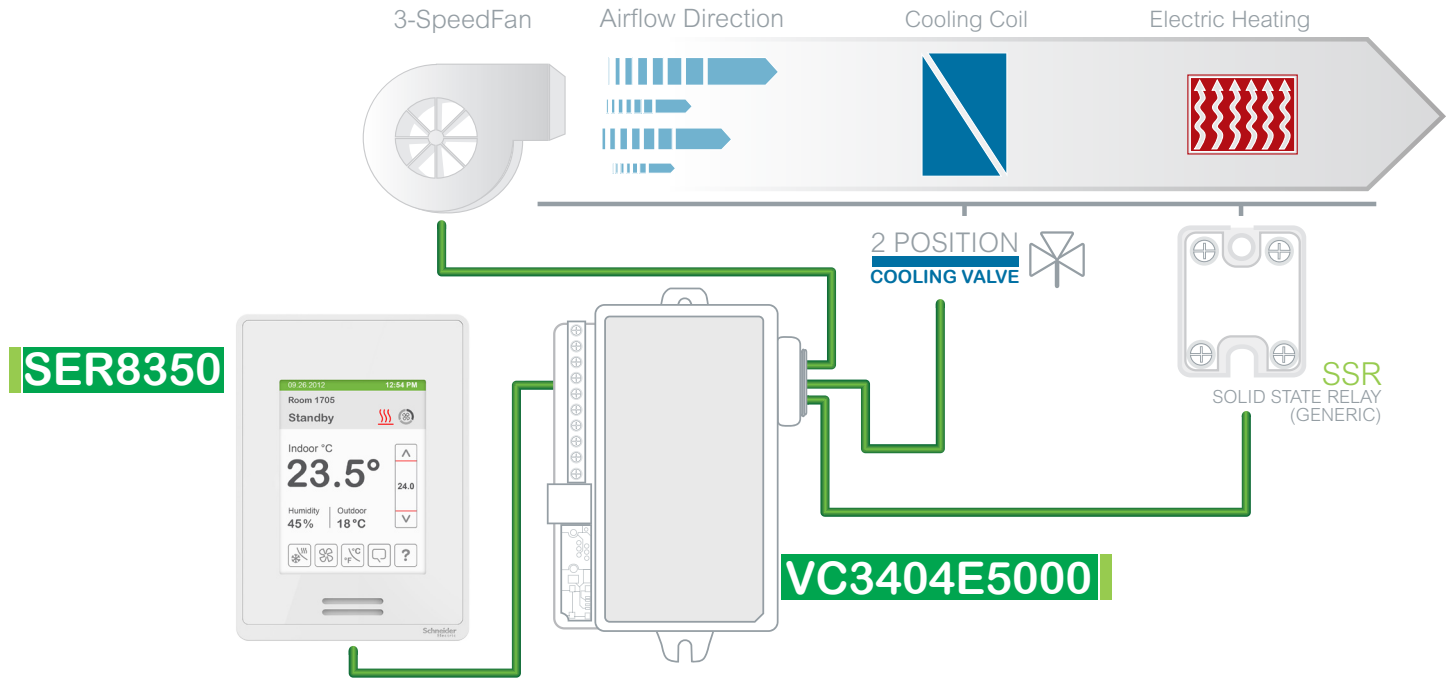

Configuration Parameter Name	Configuration settings
Fan type	3 speed
Fan menu	L-M-H-A
Fan cont. heat	On
Pulsed heating	On
No. of pipes	2
Operation sequence	Cool/Heat (Cooling with electric reheat)

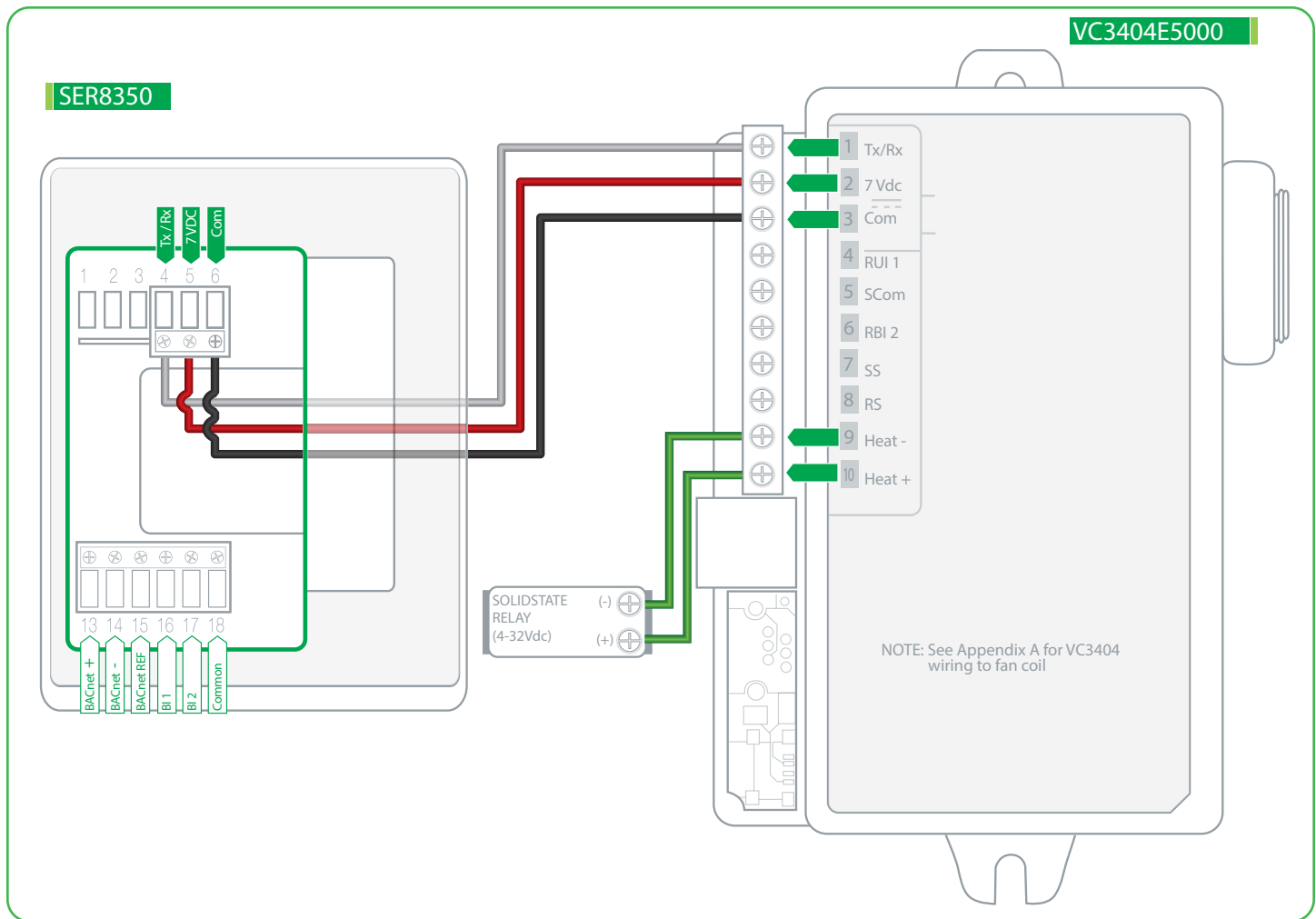

## Sequence of Operation and Wiring

### Occupied Mode

Setpoints revert to those defined by occupied cooling and heating.

### Stand-by Mode (only available when PIR motion detector sensor is used)

Setpoints revert to those defined by stand-by cooling and heating.

### Unoccupied Mode

Setpoints revert to those defined by unoccupied heating and cooling.

### Occupied Override Mode

System reverts to occupied mode for duration determined by "ToccTime" parameter.

### On Call for Cool

Cooling valve opens to maintain room temperature.

### On Call for Heat

Electric heat operates to maintain room temperature. Cooling valve closes and dehumidification is disabled.

### On a Demand for Dehumidification

Dehumidification achieved via cooling coil using reheat if necessary.

Dehumidification only allowed in COOL mode or if cooling is enabled in AUTO mode.

Dehumidification disabled if room temperature falls below low ambient lockout temperature, which is cooling setpoint minus configuration defined deadband value.

### 3 Speed Fan Operation

#### System Off

Brown, blue and red wires are not energized

#### System On: (Fan modes)

- Low: red wire is energized
- Med: blue wire is energized
- High: brown wire is energized.
- Auto: When there is no demand, brown, blue and red wires are not energized. On demand, system will automatically switch “on” low (red), medium (blue) or high (brown) speed.

#### Options

- Wireless adapter modules are available. (see Appendix B for network wiring).
- Remote wall mount or return duct sensor ready.
- Can be configured for 2-pipe systems with changeover.
- Binary inputs can be configured to control occupancy via door or window contact, remote motion sensor, remote night setback, or provide alarms for service or filter monitoring.
- Universal input can be configured for changeover sensor.

**SpaceLogic SER8350/SE8350 [ Application Guide ]**

**SER8350 WITH VC3504 RELAY: HEATING/COOLING WITH CHANGEOVER SENSOR 2-PIPE FAN COIL UNIT WITH 3-SPEED FAN**

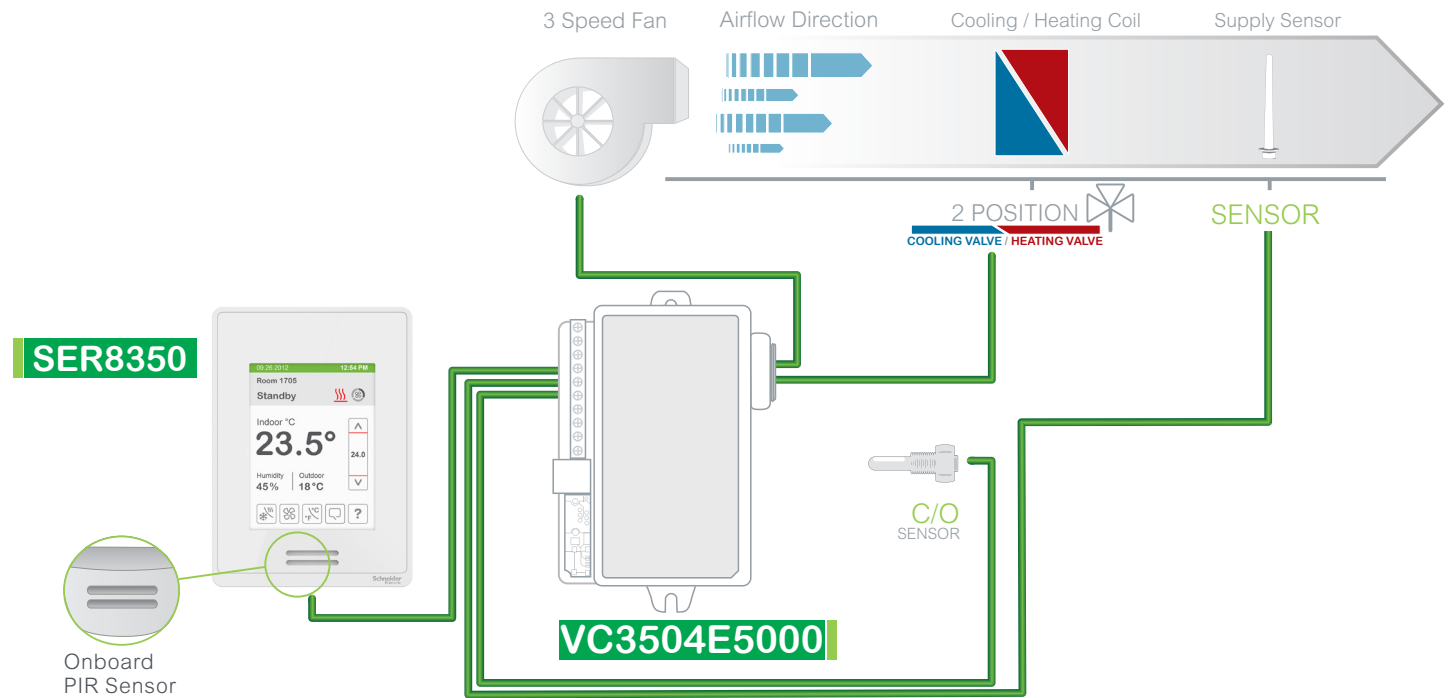

Configuration Parameter Name	Configuration Settings
Fan type	3 speed
Fan menu	L-M-H-A
Fan cont	On
B11 config	Window
RUI1	COS
Pipe No	2
Operation sequence	Cool only

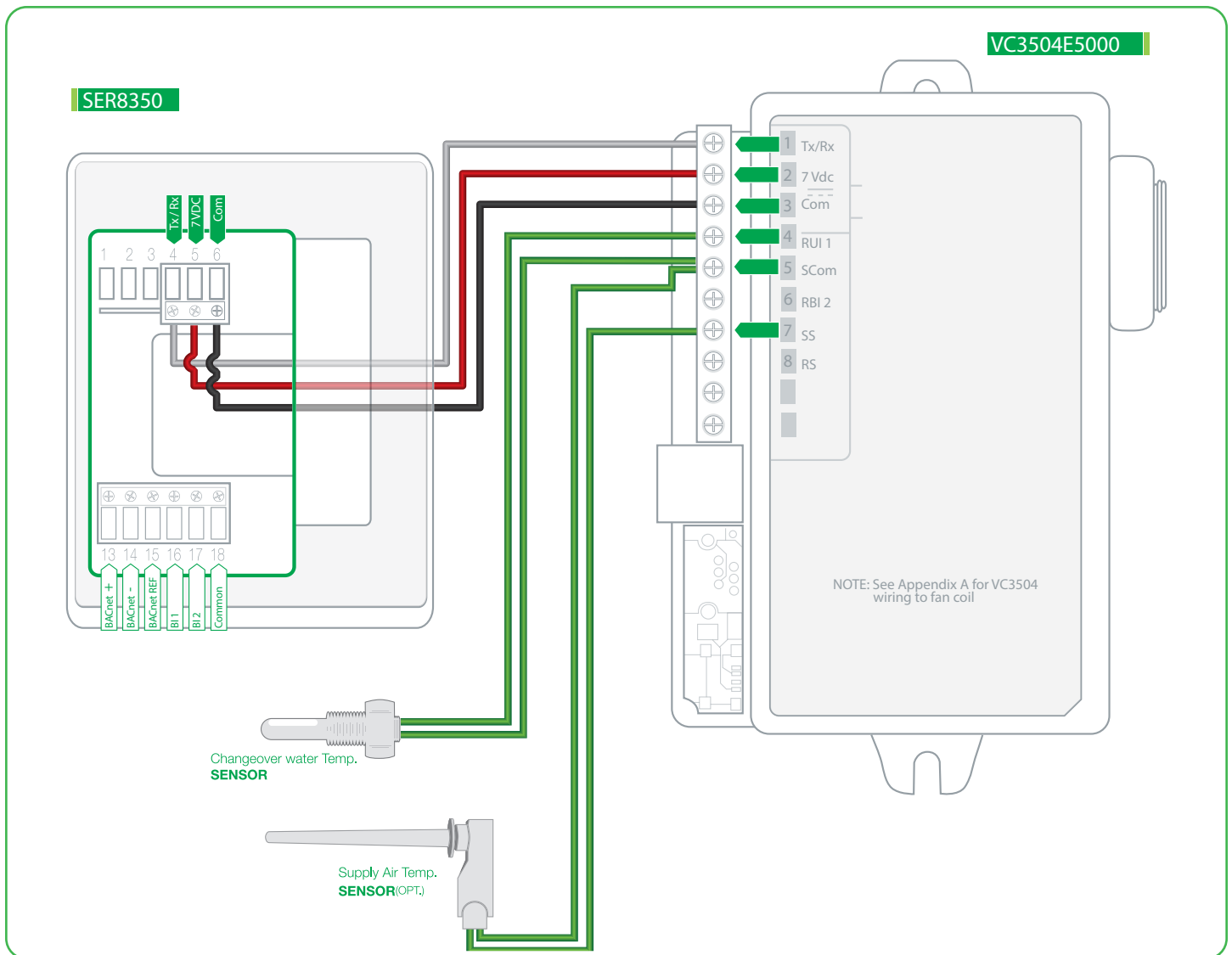

## Sequence of Operation and Wiring

### Occupied Mode

Setpoints revert to those defined by occupied cooling and heating.

### Stand-by Mode (only available when PIR motion detector sensor is used)

Setpoints revert to those defined by stand-by cooling and heating.

### Unoccupied Mode

Setpoints revert to those defined by unoccupied heating and cooling.

### Occupied Override Mode

System reverts to occupied mode for duration determined by "ToccTime" parameter.

### On Call for Cool

If supply water temperature is less than 24°C (75F), valve opens to maintain room temperature, else valve closes.

### On Call for Heat

If supply water temperature is greater than 25°C (77F), valve opens to maintain room temperature, else the valve closes.

### Supply Air Sensor

Only used for monitoring. Shows automatically if sensor is connected.

### Wireless Window Switch

Wireless window switch automatically locks out heating/cooling when window is opened.

## Options

- Wireless adapter modules are available. (see Appendix B for network wiring).
- Remote wall mount or return duct sensor ready.
- Binary inputs can be configured to control occupancy via door or window contact, remote motion sensor, remote night setback, or provide alarms for service or filter monitoring.

## 3 Speed Fan Operation

### System Off

Brown, blue and red wires are not energized

### System On: (Fan modes)

- Low: red wire is energized
- Med: blue wire is energized
- High: brown wire is energized.
- Auto: When there is no demand, brown, blue and red wires are not energized. On demand, system will automatically switch “on” low (red), medium (blue) or high (brown) speed.

## SER8350 WITH VC3514 RELAY: HEATING/COOLING 2-PIPE FAN COIL UNIT WITH 3-SPEED FAN, FRESH AIR DAMPER AND 2-POSITION VALVES

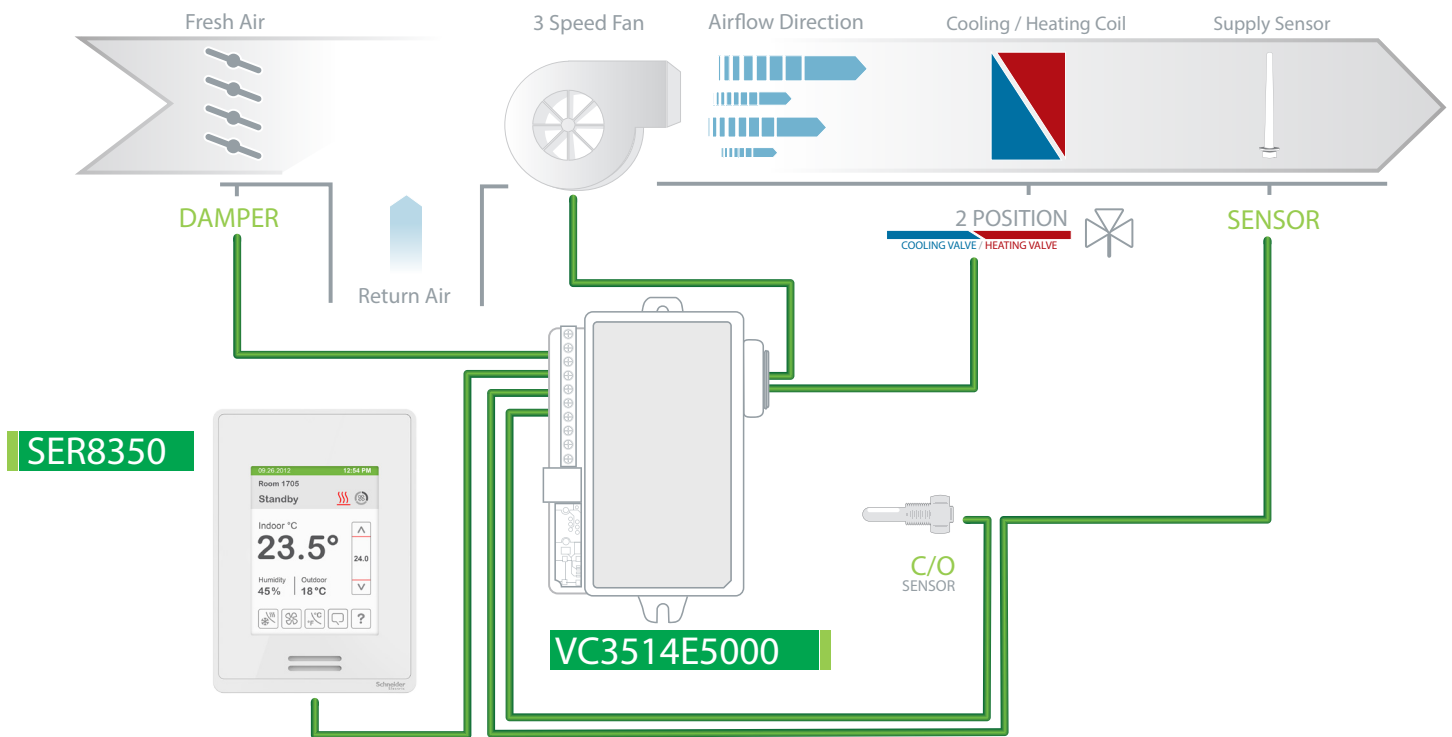

Configuration Parameter Name	Configuration Settings
Fan control	3 speed
Fan menu	L-M-H-A
Fan cont. heat	On
RUI1	COS
Pulsed Heating	Occ Out
Pipe no.	2
Seq. operation	Cool

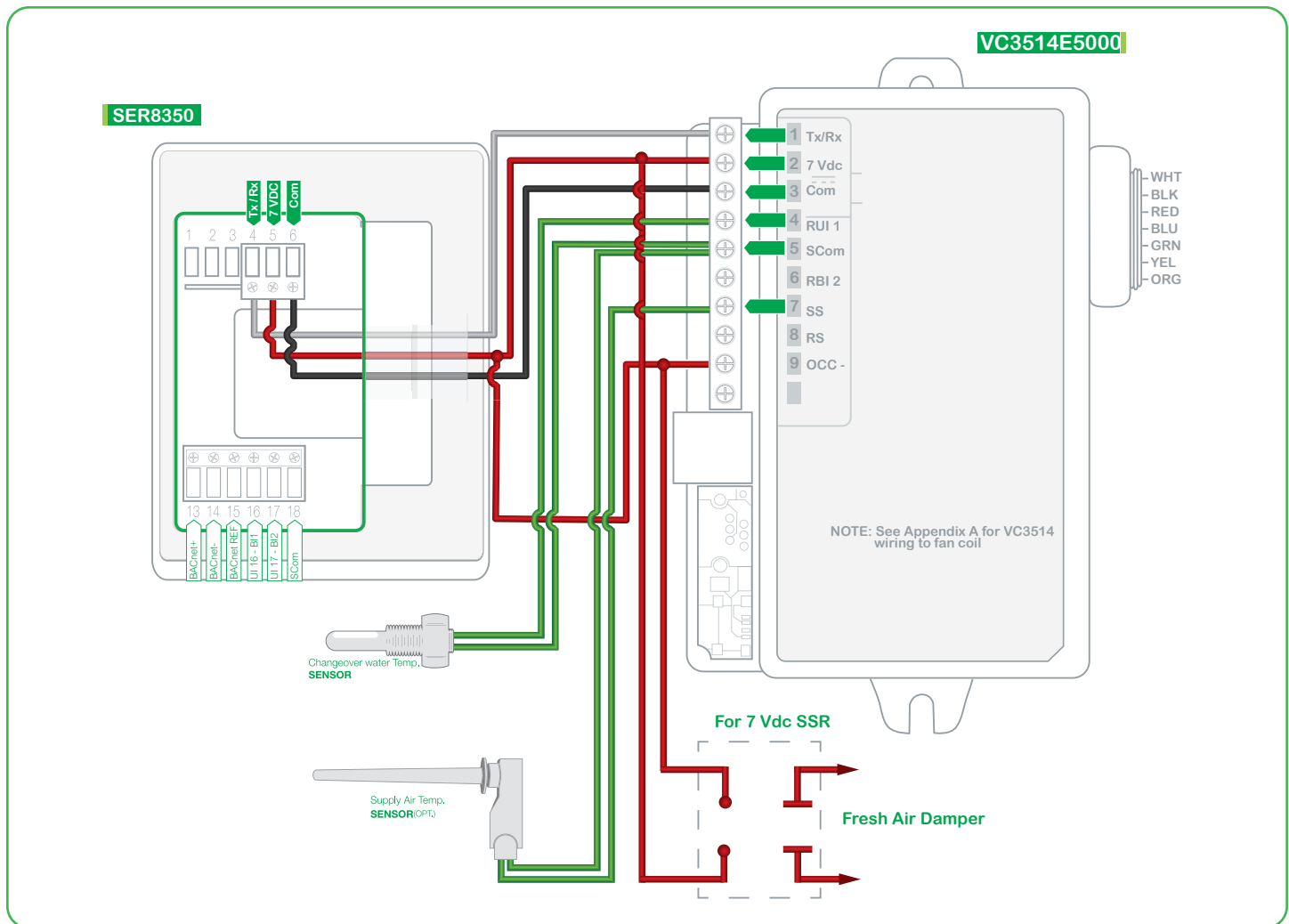

## Sequence of Operation and Wiring

### Occupied Mode

Setpoints revert to those defined by occupied cooling and heating. The occupancy output opens fresh air damper to minimum position.

### Stand-by Mode (only available when PIR motion detector sensor is used)

Setpoints revert to those defined by stand-by cooling and heating.

### Unoccupied Mode

Setpoints revert to those defined by unoccupied heating and cooling. The fresh air damper closes.

### Occupied Override Mode

System reverts to occupied mode for duration determined by "ToccTime" parameter.

### On Call for Cool

If supply water temperature is less than 24°C (75F), cooling valve opens to maintain room temperature, else the valve closes.

### On Call for Heat

If supply water temperature is greater than 25°C (77F), heating valve opens to maintain room temperature, else the valve closes.

### Supply Air Sensor

Only used for monitoring. Shows automatically if sensor is connected.

## Options

- Wireless adapter modules are available. (see Appendix B for network wiring).
- Remote wall mount or return duct sensor ready.
- Binary inputs can be configured to control occupancy via door or window contact, remote motion sensor, remote night setback, or provide alarms for service or filter monitoring.

## 3 Speed Fan Operation

### System Off

Brown, blue and red wires are not energized

### System On: (Fan modes)

- Low: red wire is energized
- Med: blue wire is energized
- High: brown wire is energized.
- Auto: When there is no demand, brown, blue and red wires are not energized. On demand, system will automatically switch "on" low (red), medium (blue) or high (brown) speed.

SER8350 WITH VC3500 AND VC3300 RELAYS: HEATING/COOLING 4-PIPE FAN COIL UNIT WITH 3-SPEED FAN AND 2-POSITION VALVES WITH SLAVE RELAY PACK

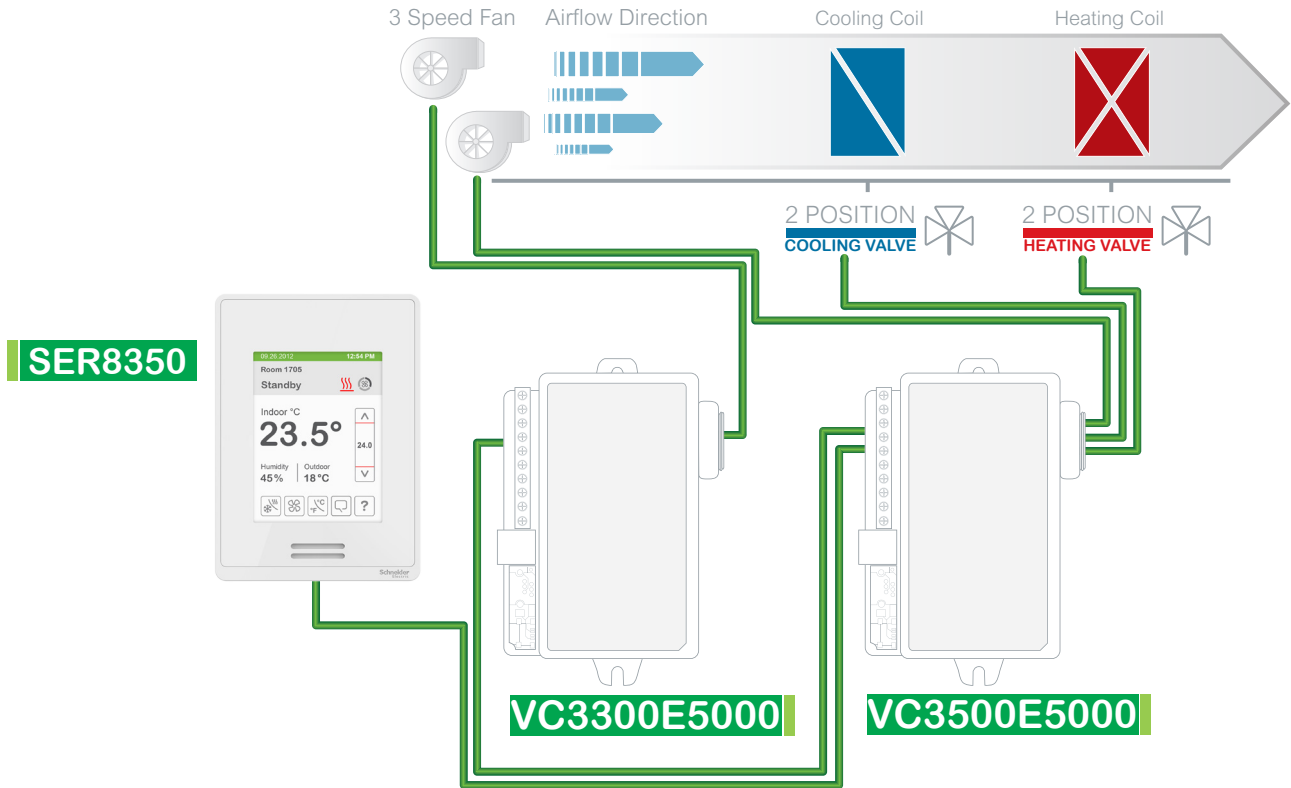

Configuration Parameter Name	Configuration Settings
Fan type	3 speed
Fan menu	L-M-H-A
Fan cont. heat	On
Pipe No	4
Operation sequence	Cool/Heat

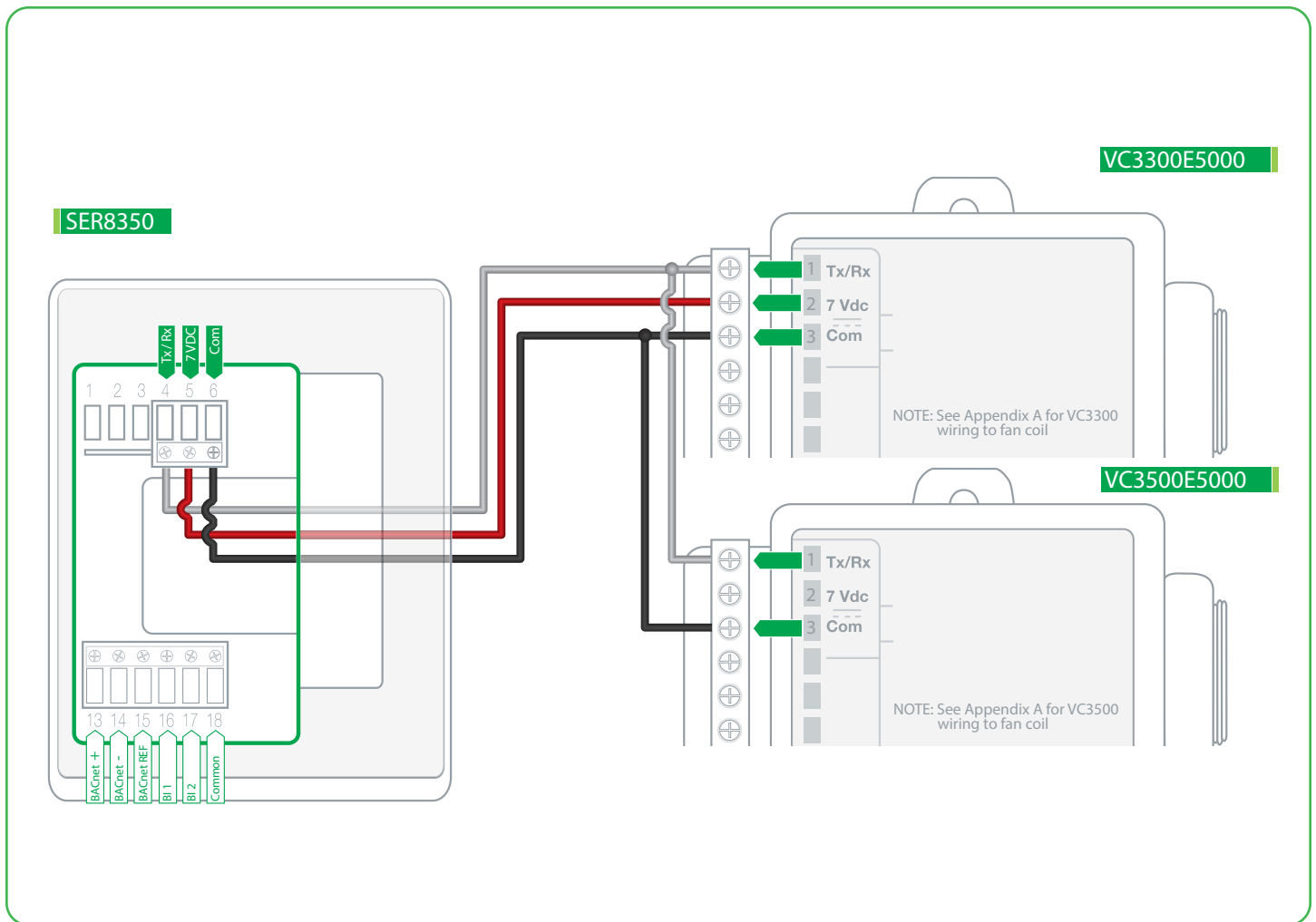

## Sequence of Operation and Wiring

### Occupied Mode

Setpoints revert to those defined by occupied cooling and heating.

### Stand-by Mode (only available when PIR motion detector sensor is used)

Setpoints revert to those defined by stand-by cooling and heating.

### Unoccupied Mode

Setpoints revert to those defined by unoccupied heating and cooling.

### Occupied Override Mode

System reverts to occupied mode for duration determined by "ToccTime" parameter.

### On Call for Cool

Cooling valve opens to maintain room temperature. Heating valve closes.

### On Call for Heat

Heating valve opens to maintain room temperature. Cooling valve closes.

## Options

- Wireless adapter modules are available. (see Appendix B for network wiring).
- Can be configured for 2-pipe systems without changeover.
- Binary inputs can be configured to control occupancy via door or window contact, remote motion sensor, remote night setback, or provide alarms for service or filter monitoring.

## 3 Speed Fan Operation

### System Off

Brown, blue and red wires are not energized

### System On: (Fan modes)

- Low: red wire is energized
- Med: blue wire is energized
- High: brown wire is energized.
- Auto: When there is no demand, brown, blue and red wires are not energized. On demand, system will automatically switch "on" low (red), medium (blue) or high (brown) speed.

SER8350 WITH VC3504 RELAY: HEATING/COOLING WITH CHANGEOVER SENSOR 2-PIPE FAN COIL UNIT WITH 3-SPEED FAN AND 2-POSITION VALVES

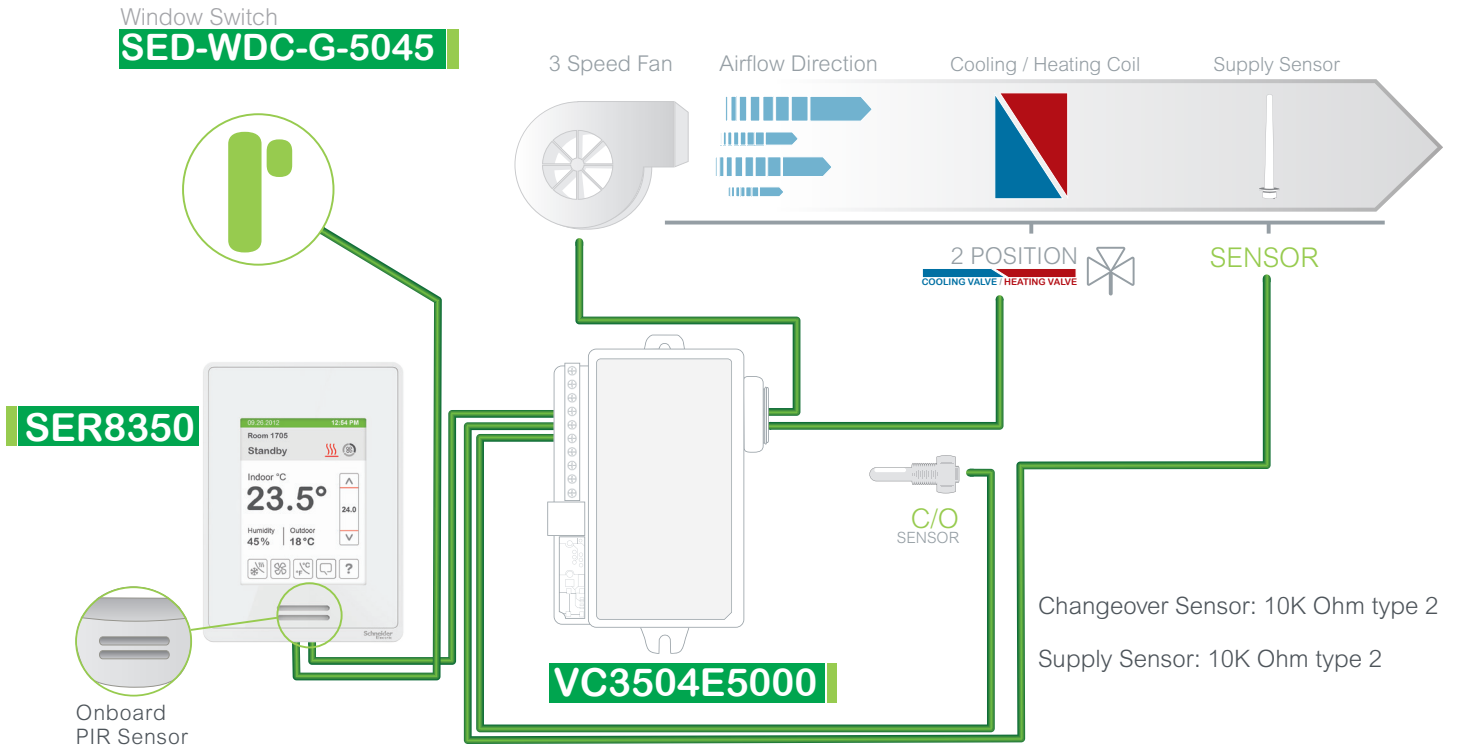

Configuration Parameter Name	Configuration Settings
Fan type	3 speed
Fan menu	L-M-H-A
Fan cont. heat	On
B11 config	Window
RU11	COS
No. of pipes	2
Operation sequence	Cool only

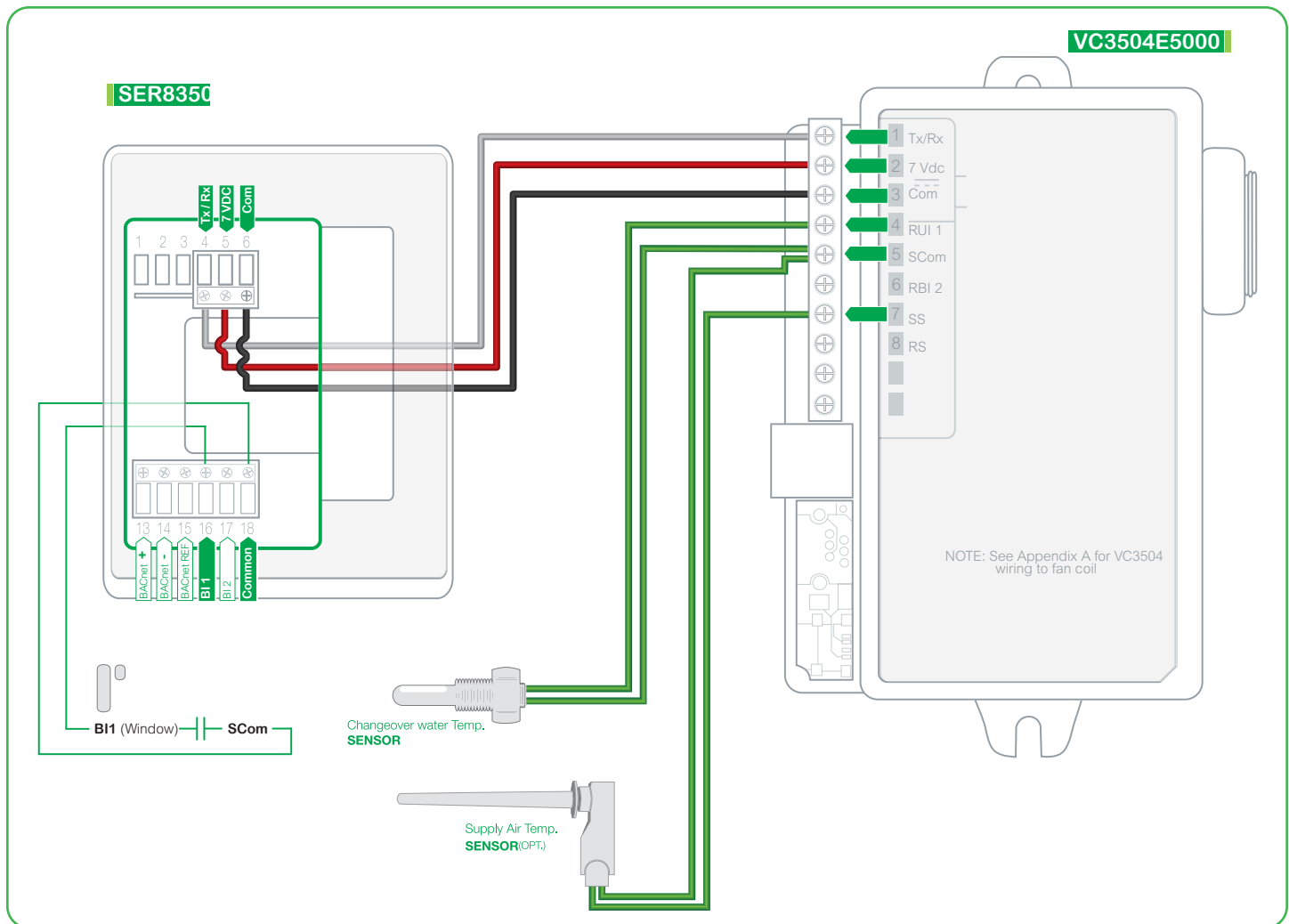

## Sequence of Operation and Wiring

### Occupied Mode

Setpoints revert to those defined by occupied cooling and heating.

### Stand-by Mode (only available when PIR motion detector sensor is used)

Setpoints revert to those defined by stand-by cooling and heating.

### Unoccupied Mode

Setpoints revert to those defined by unoccupied heating and cooling.

### Occupied Override Mode

System reverts to occupied mode for duration determined by "ToccTime" parameter.

### On Call for Cool

If supply water temperature is less than 24°C (75F), cooling valve opens to maintain room temperature, else the valve closes.

### On Call for Heat

If supply water temperature is greater than 25°C (77F), heating valve opens to maintain room temperature, else the valve closes.

### Supply Air Sensor

Only used for monitoring. Shows automatically if sensor is connected.

### Wired Window Switch

The window switch automatically locks out heating/cooling when window opens.

## Options

- Wireless adapter modules are available. (see Appendix B for network wiring).
- Models available with factory installed PIR sensor.
- Remote wall mount or duct sensor ready.
- Can be configured for 2-pipe systems with changeover.
- Binary inputs can be configured to control occupancy via door or window contact, remote night setback, or provide alarms for service or filter monitoring.
- Universal input can be configured for changeover sensor.

## 3 Speed Fan Operation

### System Off

Brown, blue and red wires are not energized

### System On: (Fan modes)

- Low: red wire is energized
- Med: blue wire is energized
- High: brown wire is energized.
- Auto: When there is no demand, brown, blue and red wires are not energized. On demand, system will automatically switch “on” low (red), medium (blue) or high (brown) speed.

**SpaceLogic SER8350/SE8350 [ Application Guide ]**

**SER8350 WITH VC3500 RELAY: HEATING/COOLING 4-PIPE FAN COIL UNIT WITH 3-SPEED FAN AND 2-POSITION VALVES**

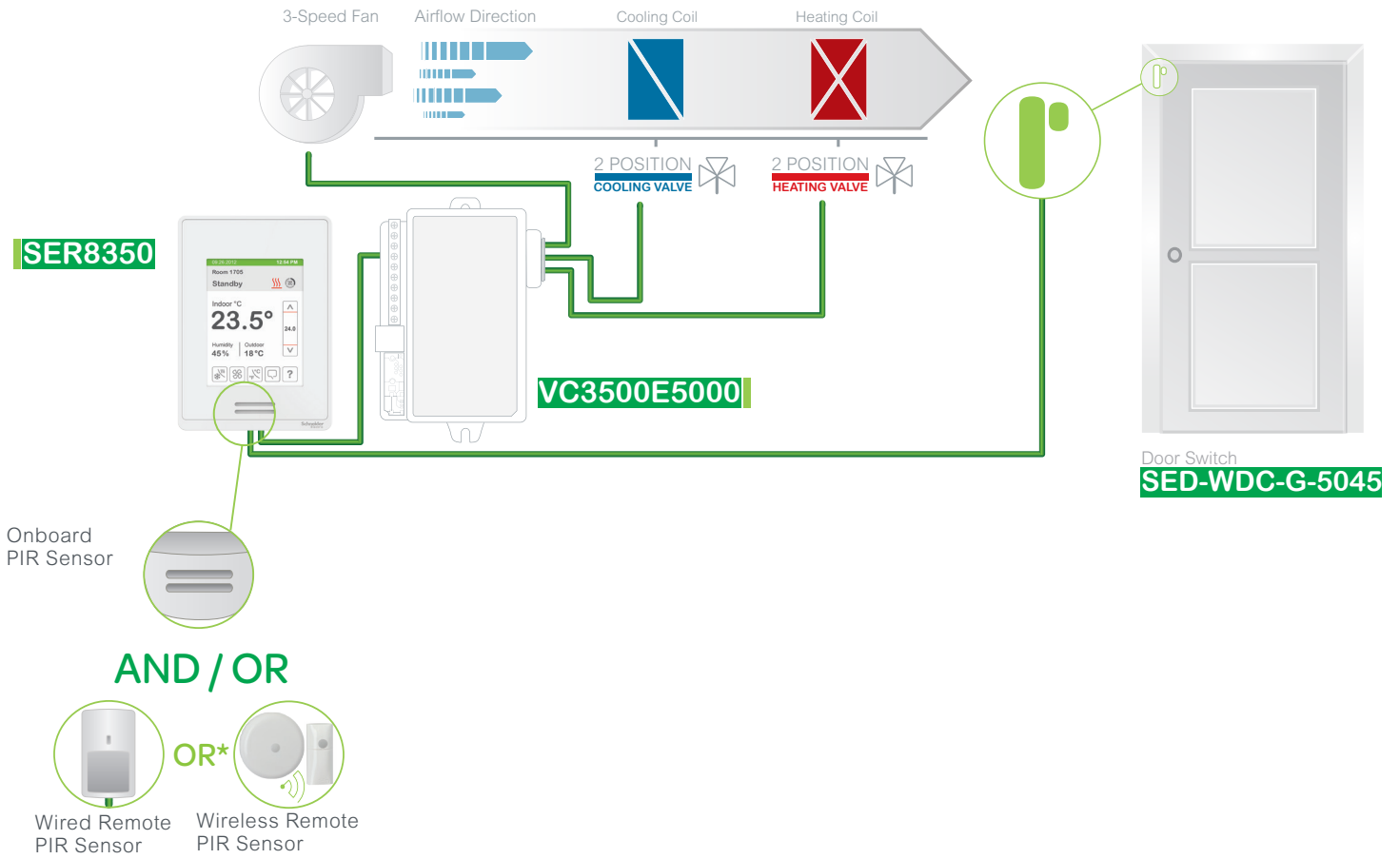

Configuration Parameter Name	Configuration Settings
Fan type	3 speed
Fan menu	L-M-H-A
Fan cont. heat	On
B11 config	Motion NO or Motion NC (remote PIR sensor only)
B12 config	Door Dry
Pipe No	4
Operation sequence	Cool/Heat

\* Wired remote sensor cannot be used at the same time as wireless remote sensor(s).

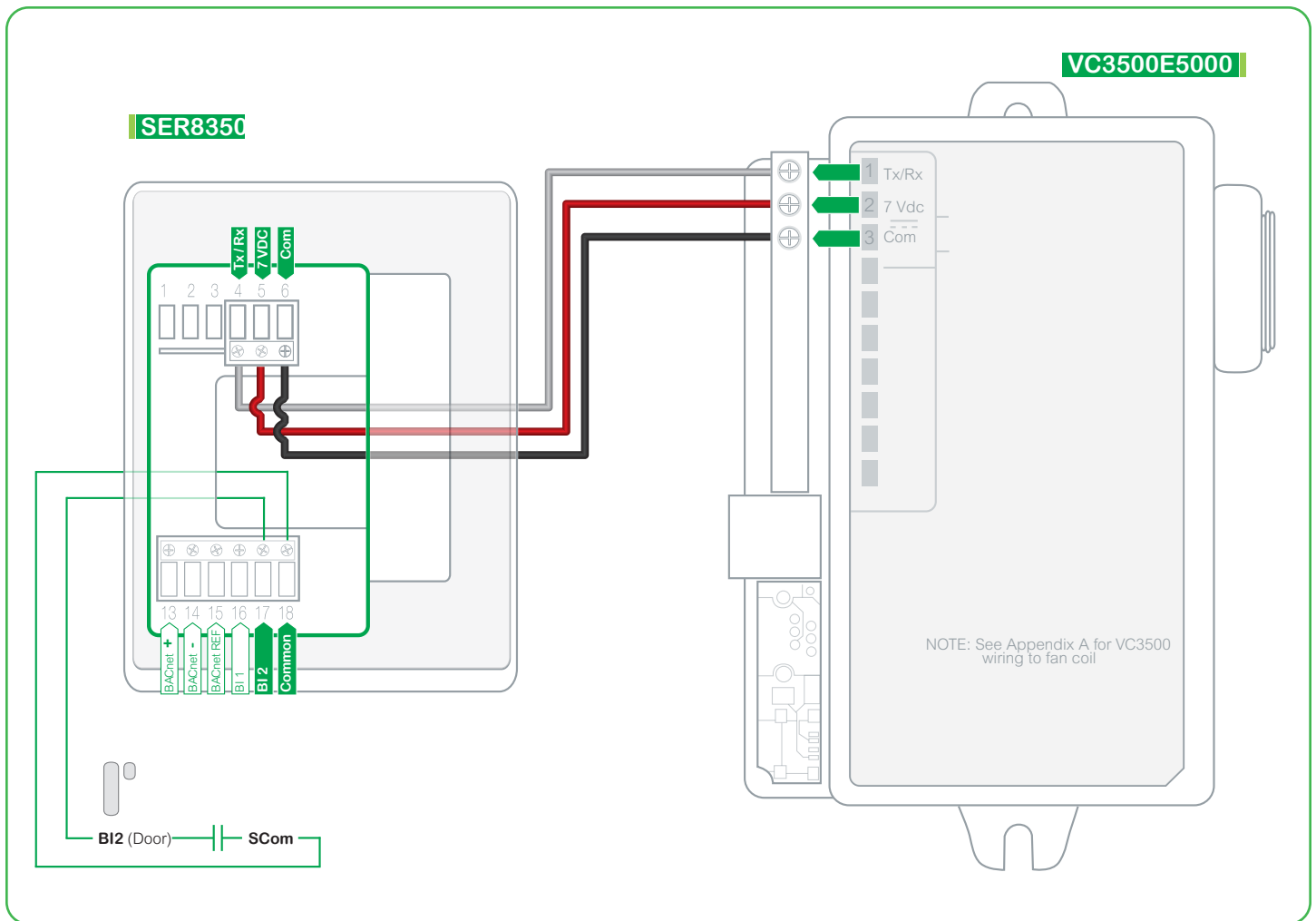

## Sequence of Operation and Wiring

### Occupied Mode

Setpoints revert to those defined by occupied cooling and heating.

### Stand-by Mode (only available when PIR motion detector sensor is used)

Setpoints revert to those defined by stand-by cooling and heating.

### Unoccupied Mode

Setpoints revert to those defined by unoccupied heating and cooling.

### On Call for Cool

Cooling valve opens to maintain room temperature. Heating valve closes.

### On Call for Heat

Heating valve opens to maintain room temperature. Cooling valve closes.

### Door Switch and Motion

Door switches occupancy to standby. Motion will switch to occupied as long as door stays closed.

## Options

- Wireless adapter modules are available. (see Appendix B for network wiring).
- Models available with factory installed PIR sensor.
- Can be configured for 2-pipe systems without changeover.
- Binary inputs can be configured to control occupancy via door or window contact, remote motion sensor, remote night setback, or provide alarms for service or filter monitoring

## 3 Speed Fan Operation

### System Off

Brown, blue and red wires are not energized

### System On: (Fan modes)

- Low: red wire is energized
- Med: blue wire is energized
- High: brown wire is energized.
- Auto: When there is no demand, brown, blue and red wires are not energized. On demand, system will automatically switch "on" low (red), medium (blue) or high (brown) speed.

**SpaceLogic**  
**SER8350 ECM**  
**Fan**

## SER8350

## ECM FAN APPLICATIONS

System	Fan	Cooling	Heating	Other
4 pipes	ECM	2 positions valve	2 positions valve	Motion detect
2 pipes	ECM	2 positions valve	Heating SSR	Dehumidification
2 pipes	ECM	2 positions valve	Changeover sensor	Fresh air damper
2 pipes	ECM	2 positions valve	Changeover sensor	Motion and Window detect
4 pipes	ECM	2 positions valve	2 positions valve	Door and motion detect

See Appendix A for VC3000 relay pack wiring.

**SpaceLogic SER8350/SE8350 [ Application Guide ]**

**SER8350 WITH VC3500 RELAY: HEATING/COOLING 4-PIPE FAN COIL UNIT WITH ECM FAN AND 2-POSITION VALVES**

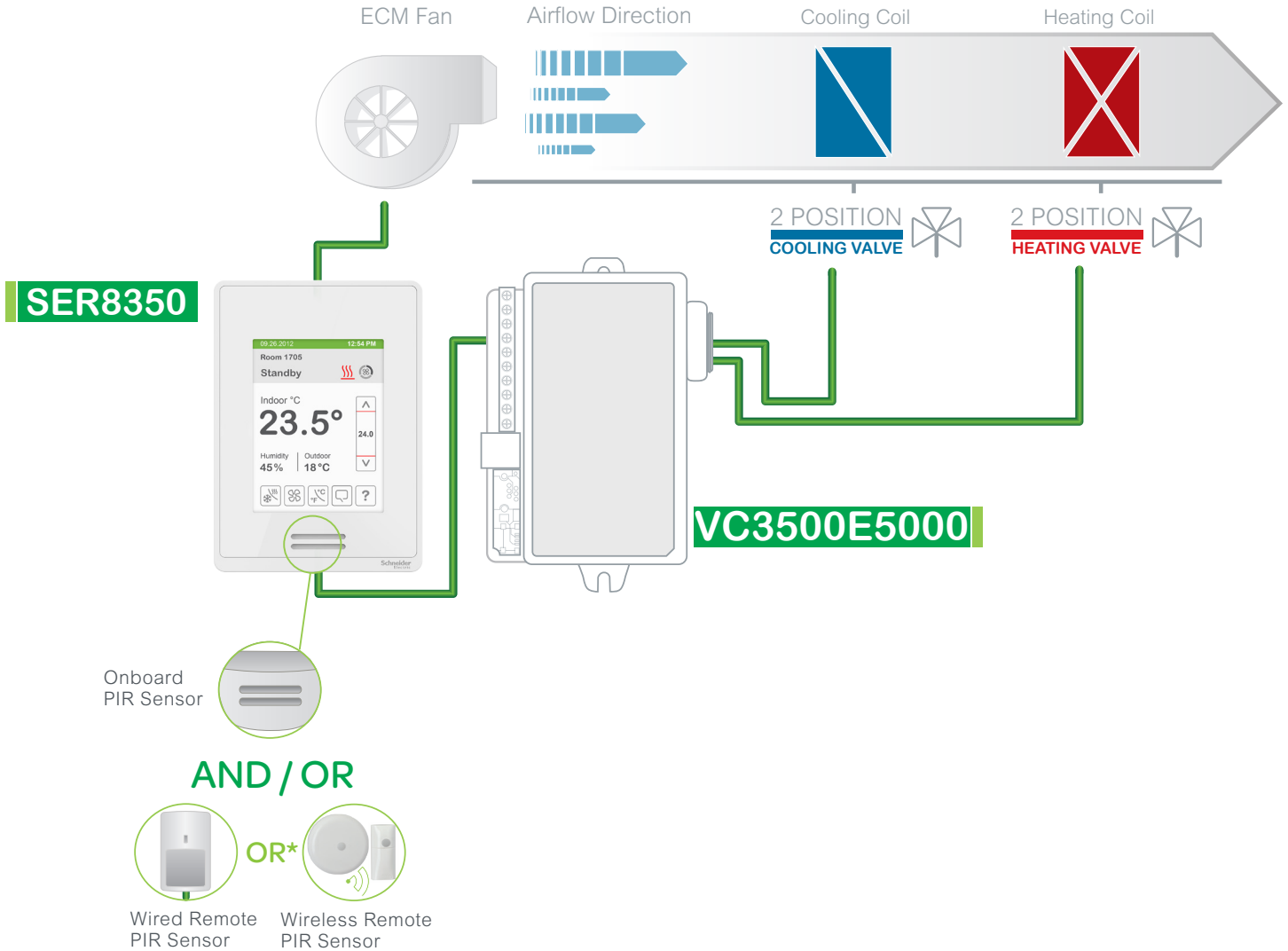

Configuration Parameter Name	Configuration Settings
Fan type	ECM
Fan menu	L-M-H-A
Fan cont. heat.	On
BI1 config	Motion NO or Motion NC (remote PIR sensor only)
BI2 config	Door Dry
Pulsed heating	Off
No. of pipes	4
Operation sequence	Cool/Heat

\* Wired remote sensor cannot be used at the same time as wireless remote sensor(s).

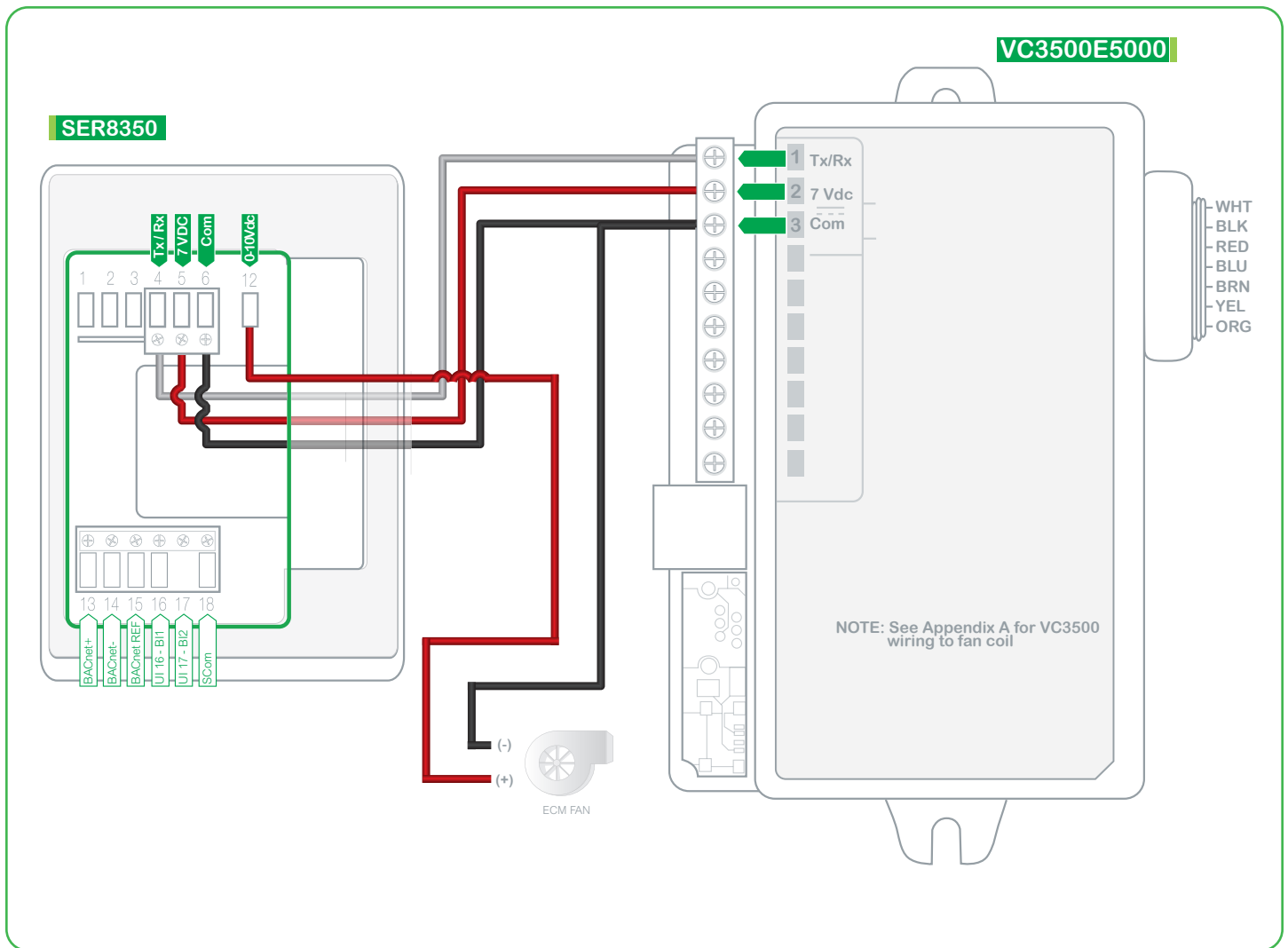

## Sequence of Operation and Wiring

### Occupied Mode

Setpoints revert to those defined by occupied cooling and heating.

### Stand-by Mode (only available when PIR motion detector sensor is used)

Setpoints revert to those defined by stand-by cooling and heating.

### Unoccupied Mode

Setpoints revert to those defined by unoccupied heating and cooling.

### Occupied Override Mode

System reverts to occupied mode for duration determined by "TocTime" parameter.

### On Call for Cool

Cooling valve opens to maintain room temperature. Heating valve closed.

### On Call for Heat

Heating valve opens to maintain room temperature. Cooling valve closed.

### Wireless Door Switch

Wireless door switch automatically toggles occupancy.

## Options

- Wireless adapter modules are available. (see Appendix B for network wiring).
- Can be configured for 2-pipe systems (without changeover).
- Binary inputs can be configured to control occupancy via door or window contact, remote motion sensor, or remote night setback

## ECM Fan Operation

### System Off

- UO12 = 0 Vdc and brown wire (fan start) is not energized

### System On: (Fan modes)

- Low: UO12 = 2.2 Vdc (adjustable from configuration menu) and (optional) brown wire “fan start” is energized.
- Med: UO12 = 6.0 Vdc (adjustable from configuration menu) and (optional) brown wire “fan start” is energized
- High: UO12 = 8.6 Vdc (adjustable from configuration menu) and (optional) brown wire “fan start” is energized.
- Auto: When there is no demand, UO12 = 0 Vdc and (optional) brown wire “fan start” is “off”. On demand, system will modulate from “low” to “high” voltages (adjustable from configuration menu) and (optional) brown wire “fan start” is energized.

## SER8350 WITH VC3404 RELAY: COOLING AND ELECTRIC HEAT 2-PIPE FAN COIL UNIT WITH ECM FAN, DEHUMIDIFICATION AND 2-POSITION VALVES

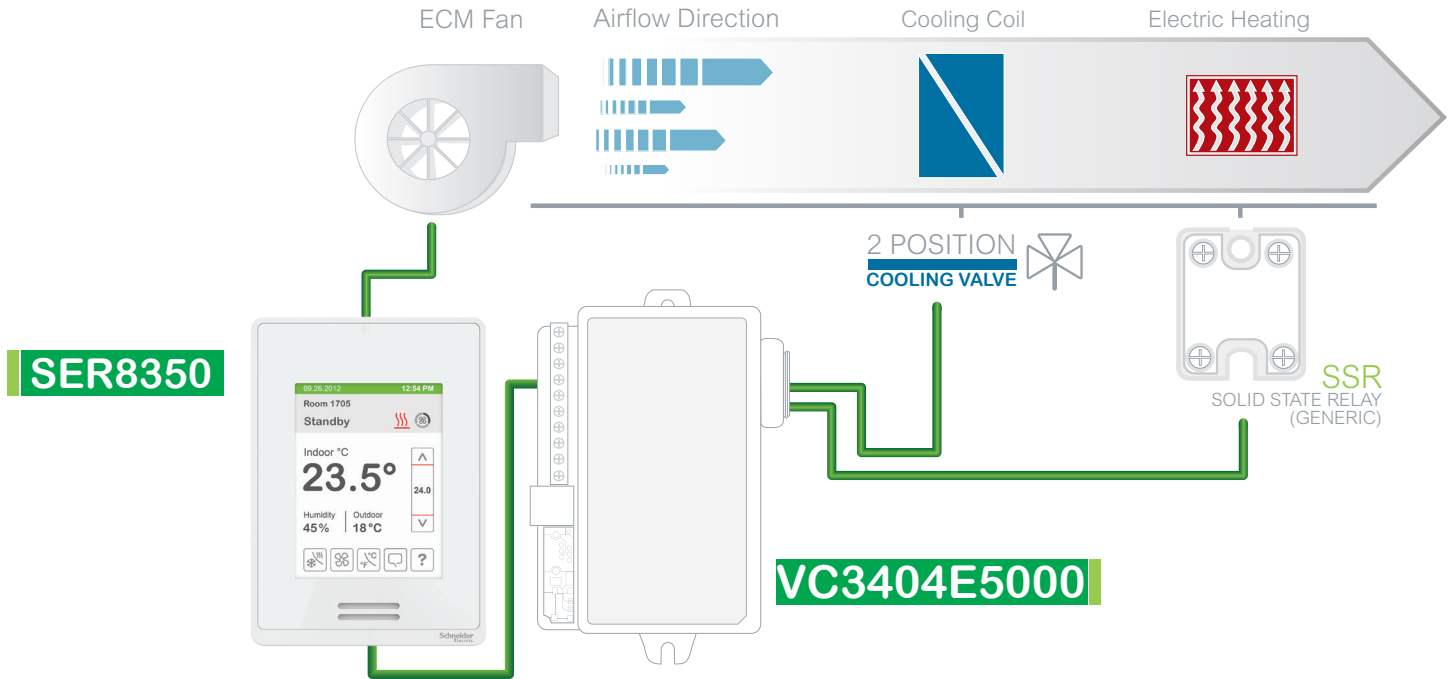

Configuration Parameter Name	Configuration settings
Fan type	ECM
Fan menu	L-M-H-A
Fan cont. heat	On
Pulsed heating	On
No. of pipes	2
Operation sequence	Cool/Heat (Cooling with electric reheat)

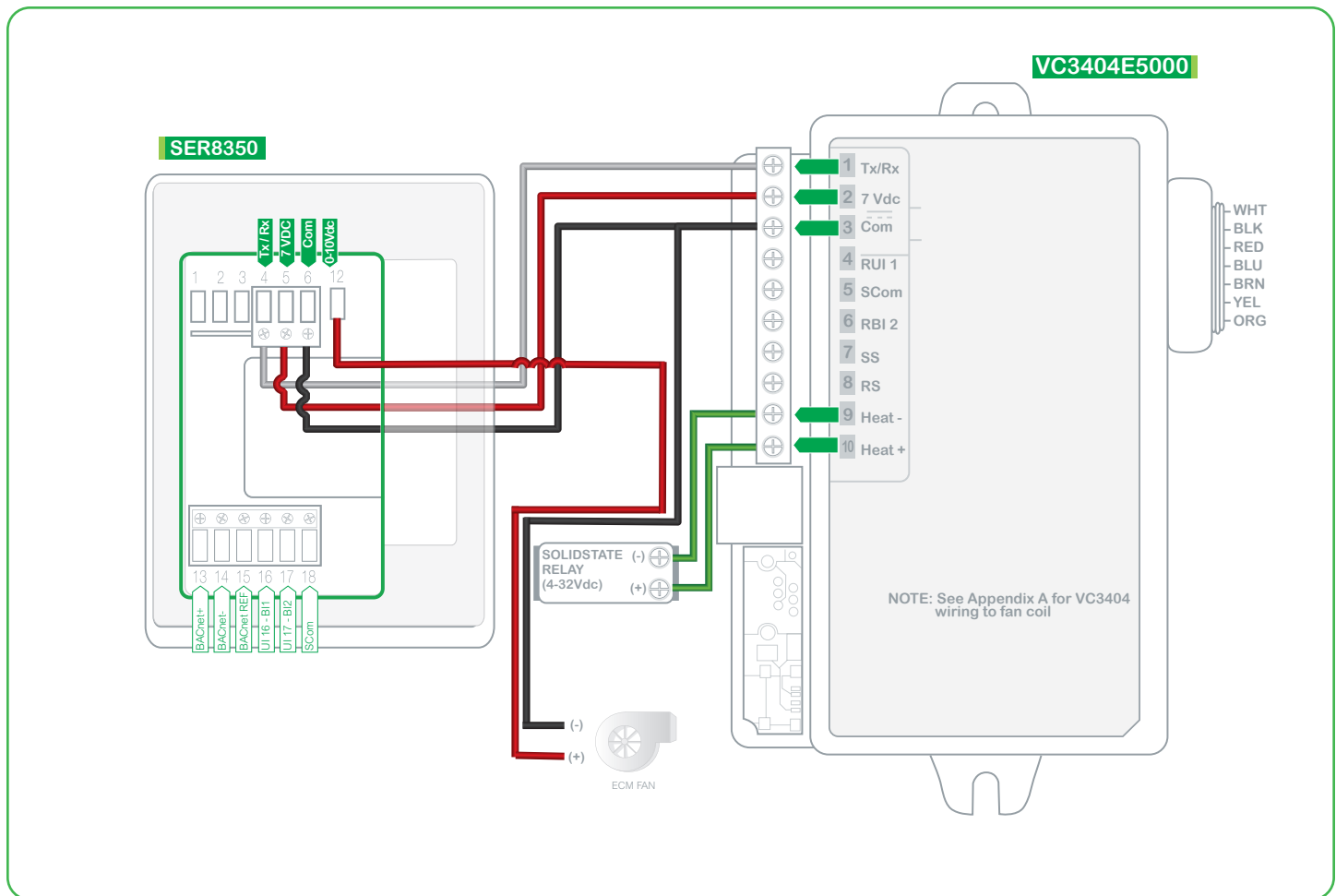

## Sequence of Operation and Wiring

### Occupied Mode

Setpoints revert to those defined by occupied cooling and heating.

### Stand-by Mode (only available when PIR motion detector sensor is used)

Setpoints revert to those defined by stand-by cooling and heating.

### Unoccupied Mode

Setpoints revert to those defined by unoccupied heating and cooling.

### Occupied Override Mode

System reverts to occupied mode for duration determined by "ToccTime" parameter.

### On Call for Cool

Cooling valve opens to maintain room temperature.

### On Call for Heat

Electric heat operates to maintain room temperature. Cooling valve closes and dehumidification is disabled.

### On a Demand for Dehumidification

Dehumidification achieved via cooling coil using reheat if necessary.

Dehumidification only allowed in COOL mode or if cooling is enabled in AUTO mode.

Dehumidification disabled if room temperature falls below low ambient lockout temperature, which is cooling setpoint minus configuration defined deadband value.

## ECM Fan Operation

### System Off

- UO12 = 0 Vdc and brown wire (fan start) is not energized

### System On: (Fan modes)

- Low: UO12 = 2.2 Vdc (adjustable from configuration menu) and (optional) brown wire “fan start” is energized.
- Med: UO12 = 6.0 Vdc (adjustable from configuration menu) and (optional) brown wire “fan start” is energized
- High: UO12 = 8.6 Vdc (adjustable from configuration menu) and (optional) brown wire “fan start” is energized.
- Auto: When there is no demand, UO12 = 0 Vdc and (optional) brown wire “fan start” is “off”. On demand, system will modulate from “low” to “high” voltages (adjustable from configuration menu) and (optional) brown wire “fan start” is energized.

## Options

- Wireless adapter modules are available. (see Appendix B for network wiring).
- Remote wall mount or return duct sensor ready.
- Can be configured for 2-pipe systems with changeover.
- Binary inputs can be configured to control occupancy via door or window contact, remote motion sensor, remote night setback, or provide alarms for service or filter monitoring.
- Universal input can be configured for changeover sensor.

**SpaceLogic SER8350/SE8350 [ Application Guide ]**

**SER8350 WITH VC3514 RELAY: HEATING/COOLING 2-PIPE FAN COIL UNIT WITH 3-SPEED FAN, FRESH AIR DAMPER AND 2-POSITION VALVES**

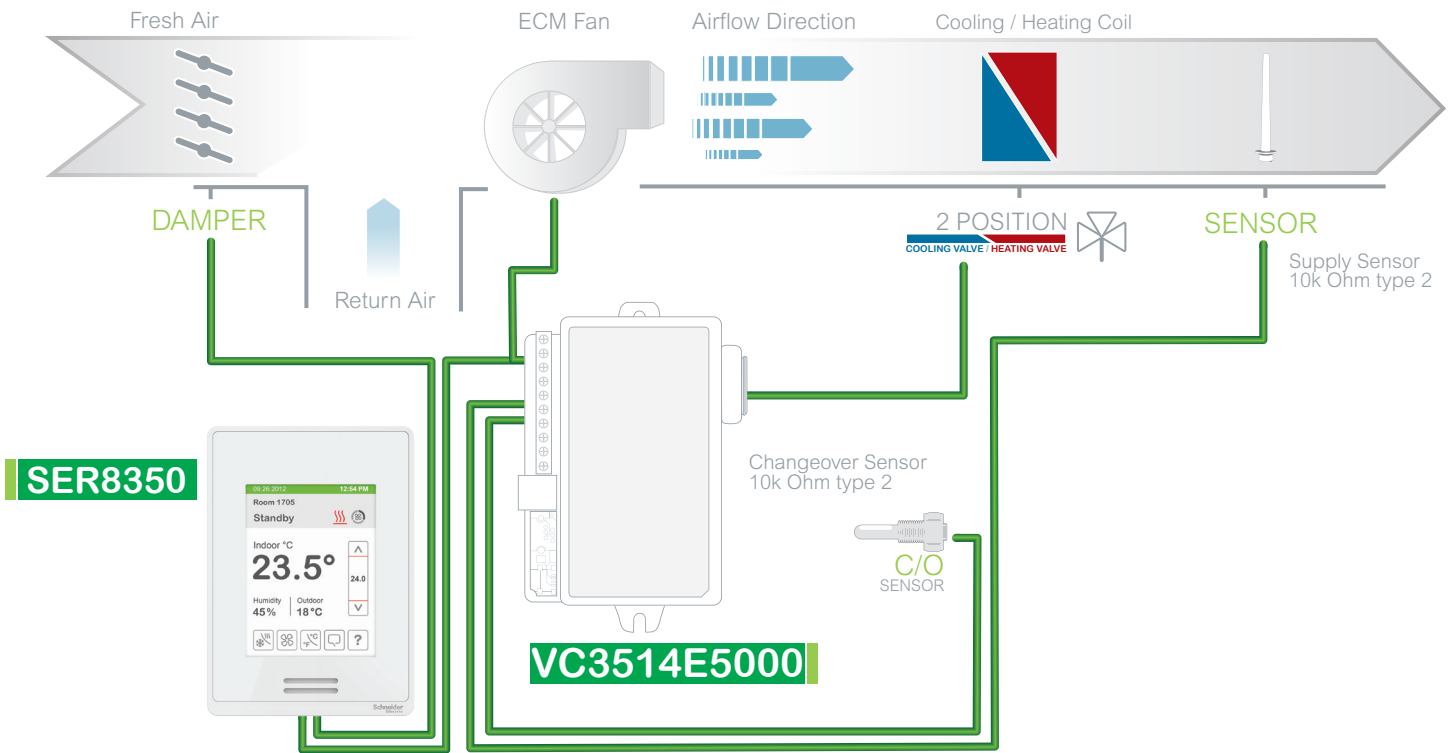

Configuration Parameter Name	Configuration Settings
Fan control	ECM
Fan menu	L-M-H-A
Fan cont. heat	On
RUI1	COS
Pulsed Heating	Occ Out
Pipe no.	2
Seq. operation	Cool

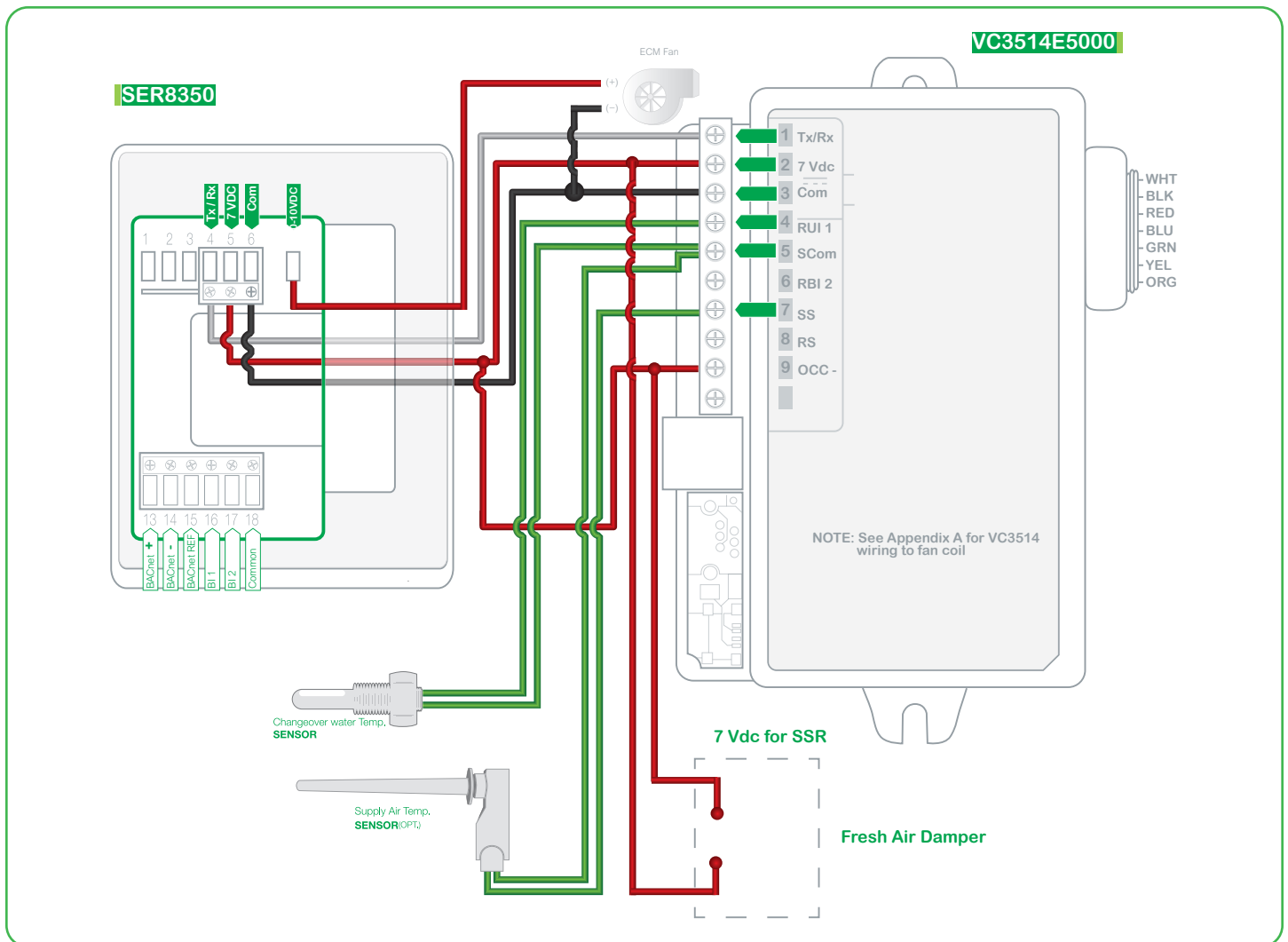

## Sequence of Operation and Wiring

### Occupied Mode

Setpoints revert to those defined by occupied cooling and heating. The occupancy output opens fresh air damper to minimum position.

### Stand-by Mode (only available when PIR motion detector sensor is used)

Setpoints revert to those defined by stand-by cooling and heating.

### Unoccupied Mode

Setpoints revert to those defined by unoccupied heating and cooling. The fresh air damper closes.

### Occupied Override Mode

System reverts to occupied mode for duration determined by "ToccTime" parameter.

### On Call for Cool

If supply water temperature is less than 24°C (75F), cooling valve opens to maintain room temperature, else the valve closes.

### On Call for Heat

If supply water temperature is greater than 25°C (77F), heating valve opens to maintain room temperature, else the valve closes.

### Supply Air Sensor

Only used for monitoring. Shows automatically if sensor is connected.

## Options

- Wireless adapter modules for BACnet models are available. (see Appendix B for network wiring).
- Remote wall mount or return duct sensor ready.
- Binary inputs can be configured to control occupancy via door or window contact, remote motion sensor, remote night setback, or provide alarms for service or filter monitoring.

## ECM Fan Operation

### System Off

- UO12 = 0Vdc and brown wire (fan start) is not energized

### System On: (Fan modes)

- Low: UO12 = 2.2 Vdc (adjustable from configuration menu) and (optional) brown wire “fan start” is energized.
- Med: UO12 = 6.0 Vdc (adjustable from configuration menu) and (optional) brown wire “fan start” is energized.
- High: UO12 = 8.6 Vdc (adjustable from configuration menu) and (optional) brown wire “fan start” is energized.
- Auto: When there is no demand, UO12 = 0 Vdc and (optional) brown wire “fan start” is “off”. On demand, system will modulate from “low” to “high” voltages (adjustable from configuration menu) and (optional) brown wire “fan start” is energized.

SER8350 WITH VC3504 RELAY: COOLING AND ELECTRIC HEAT 2-PIPE FAN COIL UNIT WITH 3-SPEED FAN AND 2-POSITION VALVES

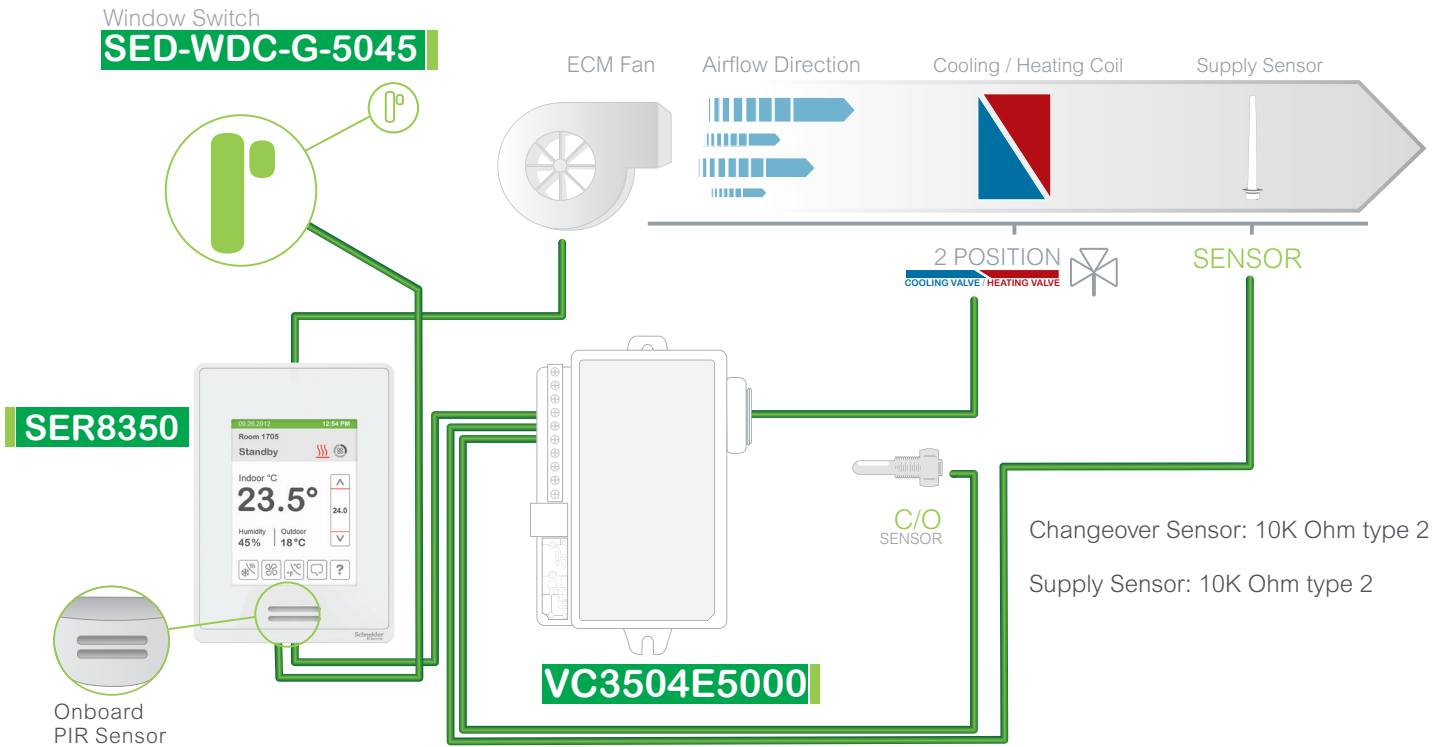

Configuration Parameter Name	Configuration Settings
Fan type	ECM
Fan menu	L-M-H-A
Fan cont. heat	On
B11 config	Window
RUI1	COS
No. of pipes	2
Operation sequence	Cool only

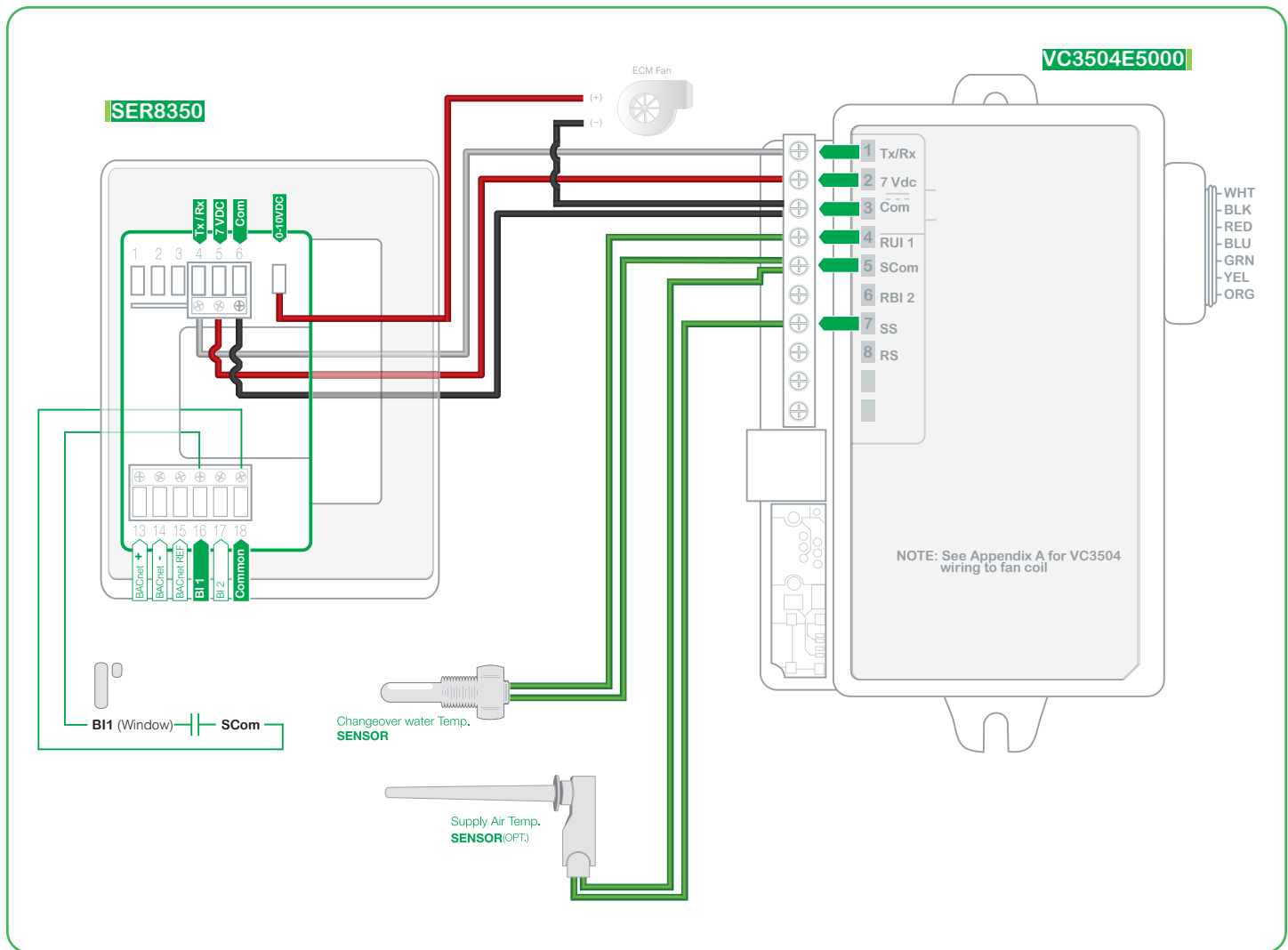

## Sequence of Operation and Wiring

### Occupied Mode

Setpoints revert to those defined by occupied cooling and heating.

### Stand-by Mode (only available when PIR motion detector sensor is used)

Setpoints revert to those defined by stand-by cooling and heating.

### Unoccupied Mode

Setpoints revert to those defined by unoccupied heating and cooling.

### Occupied Override Mode

System reverts to occupied mode for duration determined by "ToccTime" parameter.

### On Call for Cool

If supply water temperature is less than 24°C (75F), cooling valve opens to maintain room temperature, else the valve closes.

### On Call for Heat

If supply water temperature is greater than 25°C (77F), heating valve opens to maintain room temperature, else the valve closes.

### Supply Air Sensor

Only used for monitoring. Shows automatically if sensor is connected.

### Wired Window Switch

The window switch automatically locks out heating/cooling when window opens.

## Options

- Wireless adapter modules are available. (see Appendix B for network wiring).
- Models available with factory installed PIR sensor.
- Remote wall mount or duct sensor ready.
- Can be configured for 2-pipe systems with changeover.
- Binary inputs can be configured to control occupancy via door or window contact, remote night setback, or provide alarms for service or filter monitoring.
- Universal input can be configured for changeover sensor.

## ECM Fan Operation

### System Off

- UO12 = 0 Vdc and brown wire (fan start) is not energized

### System On: (Fan modes)

- Low: UO12 = 2.2 Vdc (adjustable from configuration menu) and (optional) brown wire “fan start” is energized.
- Med: UO12 = 6.0 Vdc (adjustable from configuration menu) and (optional) brown wire “fan start” is energized.
- High: UO12 = 8.6 Vdc (adjustable from configuration menu) and (optional) brown wire “fan start” is energized.
- Auto: When there is no demand, UO12 = 0 Vdc and (optional) brown wire “fan start” is “off”. On demand, system will modulate from “low” to “high” voltages (adjustable from configuration menu) and (optional) brown wire “fan start” is energized.

SpaceLogic SER8350/SE8350 [ Application Guide ]

SER8350 WITH VC3500 RELAY: HEATING/COOLING 4-PIPE FAN COIL UNIT WITH ECM FAN AND 2-POSITION VALVES

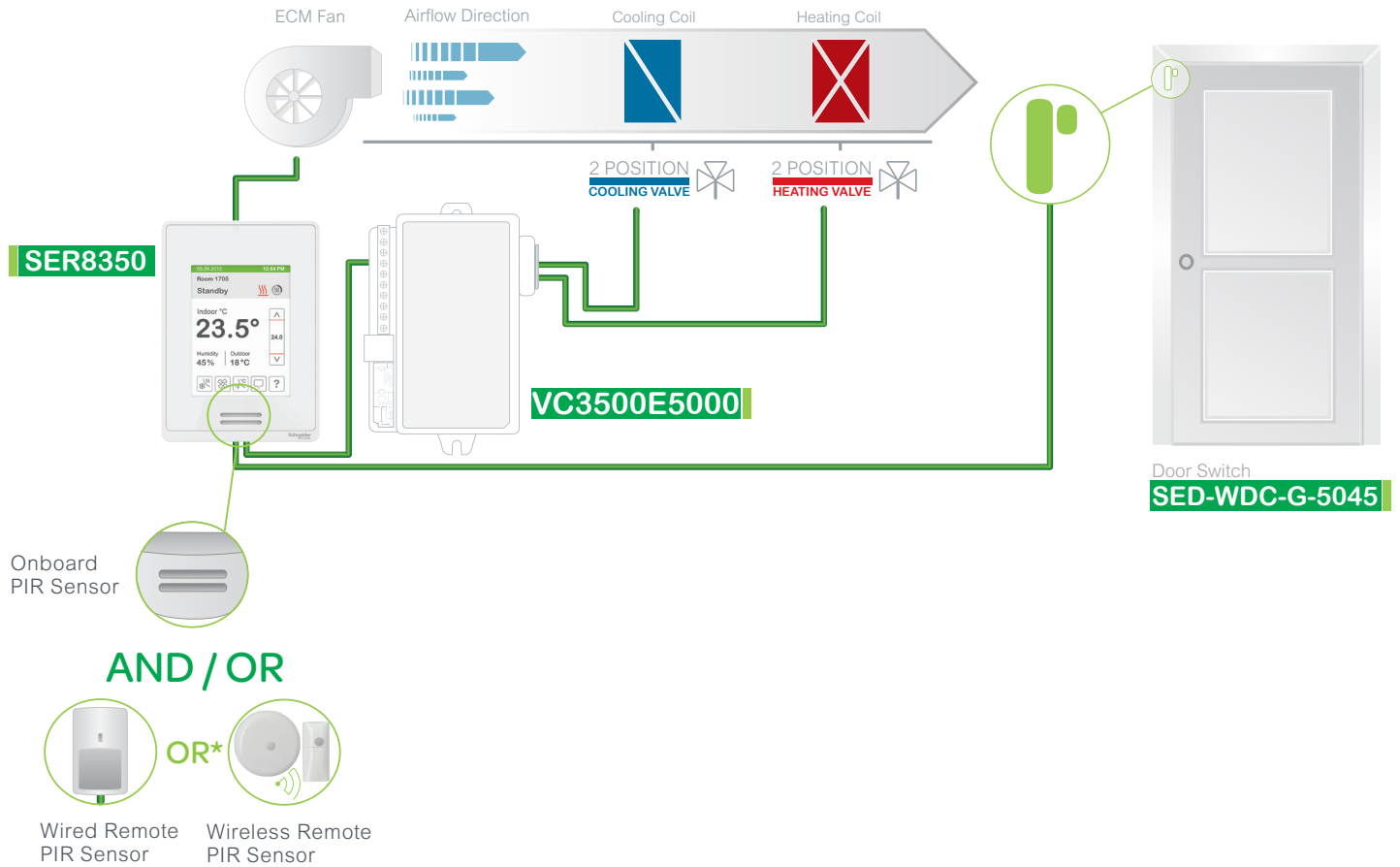

Configuration Parameter Name	Configuration Settings
Fan type	ECM
Fan menu	L-M-H-A
Fan cont. heat	On
BI1 config	Motion NO or Motion NC (remote PIR sensor only)
BI2 config	Door Dry
Pipe No	4
Operation sequence	Cool/Heat

\* Wired remote sensor cannot be used at the same time as wireless remote sensor(s).

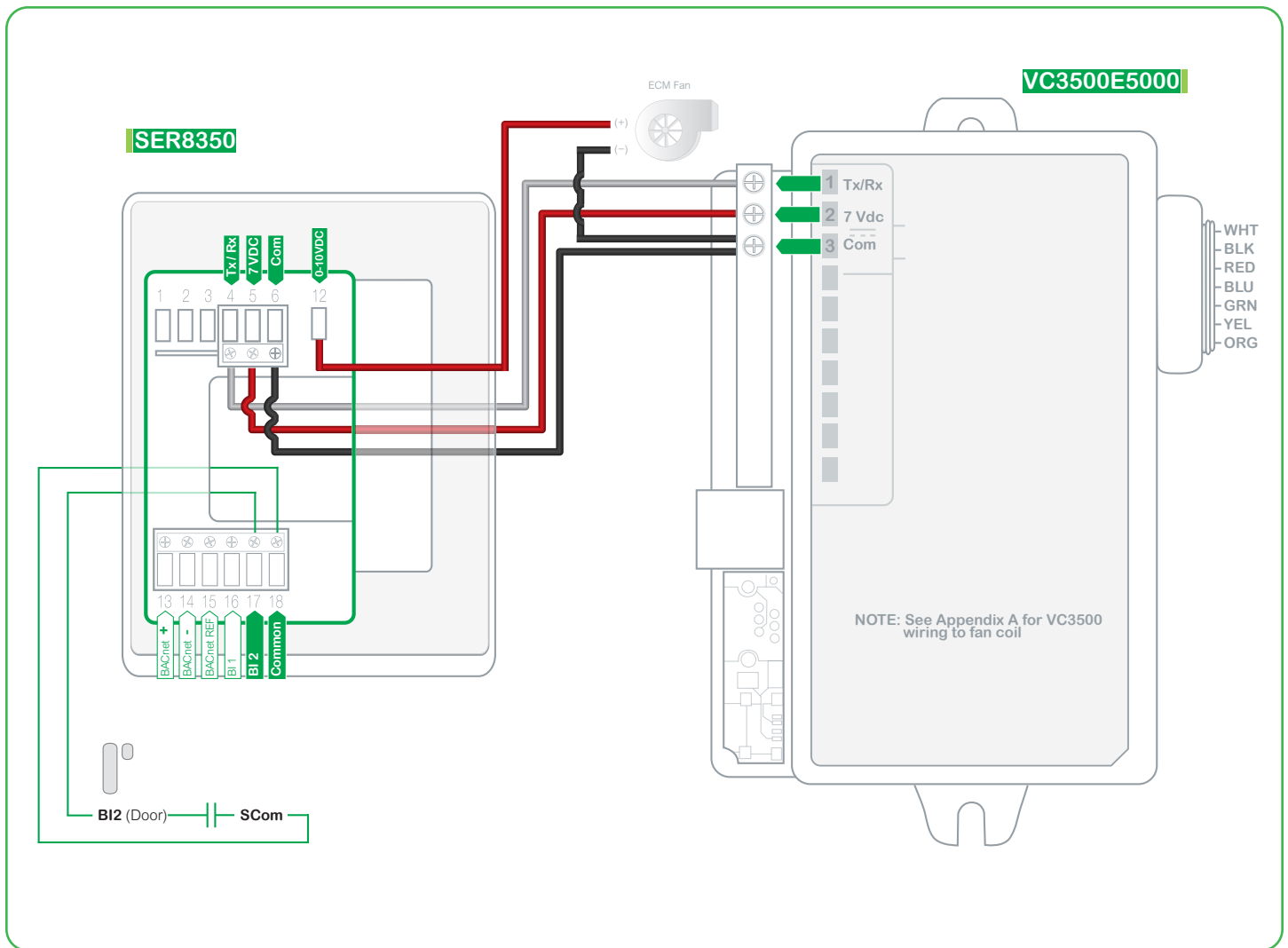

## Sequence of Operation and Wiring

### Occupied Mode

Setpoints revert to those defined by occupied cooling and heating.

### Stand-by Mode (only available when PIR motion detector sensor is used)

Setpoints revert to those defined by stand-by cooling and heating.

### Unoccupied Mode

Setpoints revert to those defined by unoccupied heating and cooling.

### On Call for Cool

Cooling valve opens to maintain room temperature. Heating valve closes.

### On Call for Heat

Heating valve opens to maintain room temperature. Cooling valve closes.

### Door Switch And Motion

Door switch automatically toggles occupancy to Standby.

Motion will switch to Occupied, as long as the door stays closed.

## Options

- Wireless adapter modules for BACnet models are available. (see Appendix B for network wiring).
- Models available with factory installed PIR sensor.
- Can be configured for 2-pipe systems without changeover.
- Binary inputs can be configured to control occupancy via door or window contact, remote motion sensor, remote night setback, or provide alarms for service or filter monitoring.

## ECM Fan Operation

### System Off

UO12 = 0 Vdc and brown wire (fan start) is not energized

### System On: (Fan modes)

- Low: UO12 = 2.2 Vdc (adjustable from configuration menu) and (optional) brown wire “fan start” is energized.
- Med: UO12 = 6.0 Vdc (adjustable from configuration menu) and (optional) brown wire “fan start” is energized
- High: UO12 = 8.6 Vdc (adjustable from configuration menu) and (optional) brown wire “fan start” is energized
- Auto: When there is no demand, UO12 = 0 Vdc and (optional) brown wire “fan start” is “off”. On demand, system will modulate from “low” to “high” voltages (adjustable from configuration menu) and (optional) brown wire “fan start” is energized.

**SpaceLogic  
SE8350 3-Speed  
Fan**

## SE8350

## 1, 2 OR 3-SPEED FAN APPLICATIONS

System	Fan	Cooling	Heating	Other
4 pipes	3 Speed	Tri-state valve actuator	Tri-state valve actuator	Door and motion detect + dehumidification
4 pipes	3 Speed	0-10 Vdc valve actuator	0-10 Vdc valve actuator	Motion detect + dehumidification
4 pipes	3 Speed	2 positions valve actuator	2 positions valve actuator	Motion detect + dehumidification
2 pipes	1 Speed	2 positions valve actuator	None	Fresh air damper
4 pipes	3 Speed	0-10 Vdc valve actuator	2 positions valve actuator reheat	---
2 pipes	3 Speed	0-10 Vdc valve actuator	None	---
2 pipes	3 Speed	0-10 Vdc valve actuator	Electric reheat	---

SE8350 HEATING/COOLING 4-PIPE FAN COIL UNIT WITH 3-SPEED FAN, TRI-STATE FLOATING VALVES AND DEHUMIDIFICATION SEQUENCE FOR LOW VOLTAGE

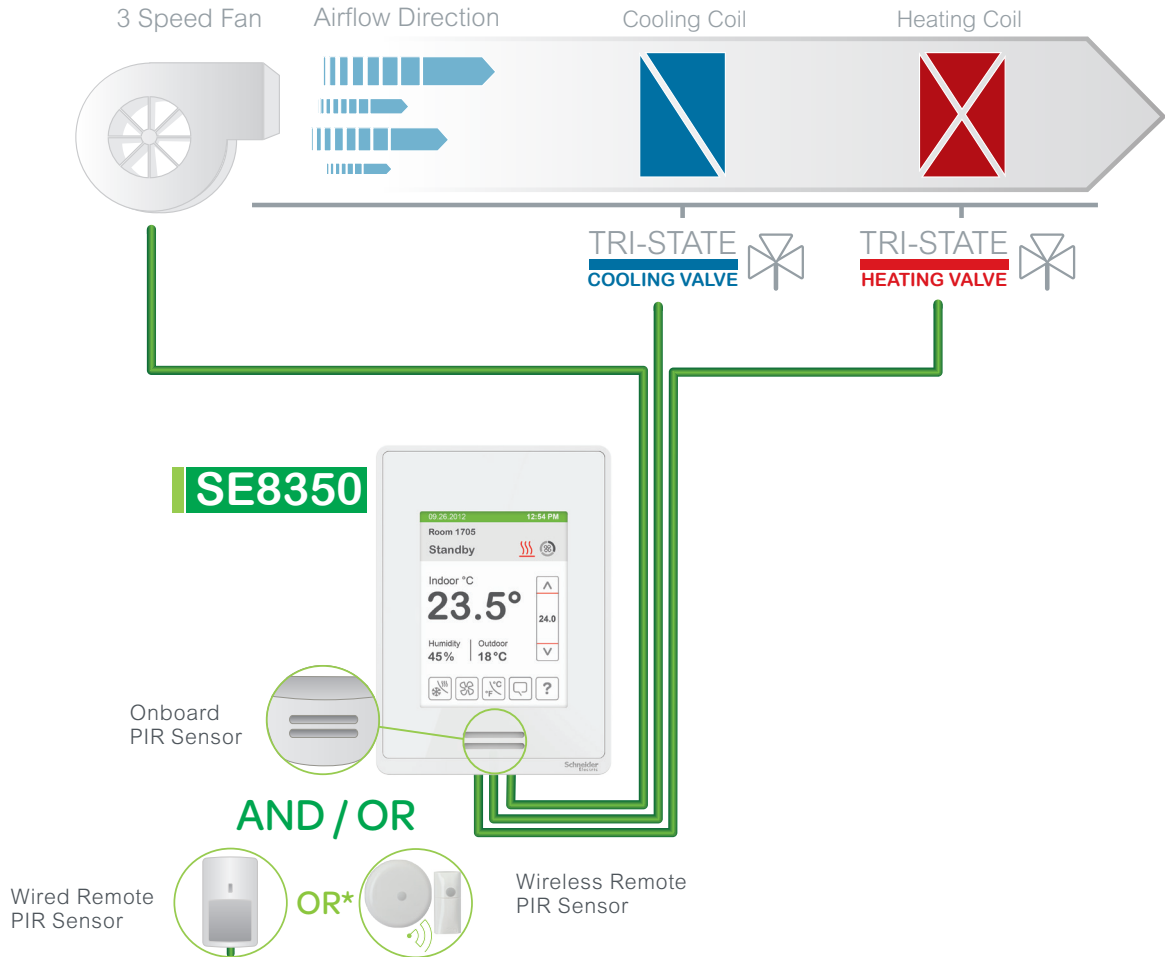

Configuration Parameter Name	Configuration Settings
Fan type	3 speed
Fan menu	L-M-H-A
Ctrl. type out1	Floating
Ctrl. type out2	Same as 1
UI16 config	Motion NO or Motion NC (remote PIR sensor only)
UI17 config	Door Dry
No. of pipes	4
Operation sequence	Cool/Heat

\* Wired remote sensor cannot be used at the same time as wireless remote sensor(s).

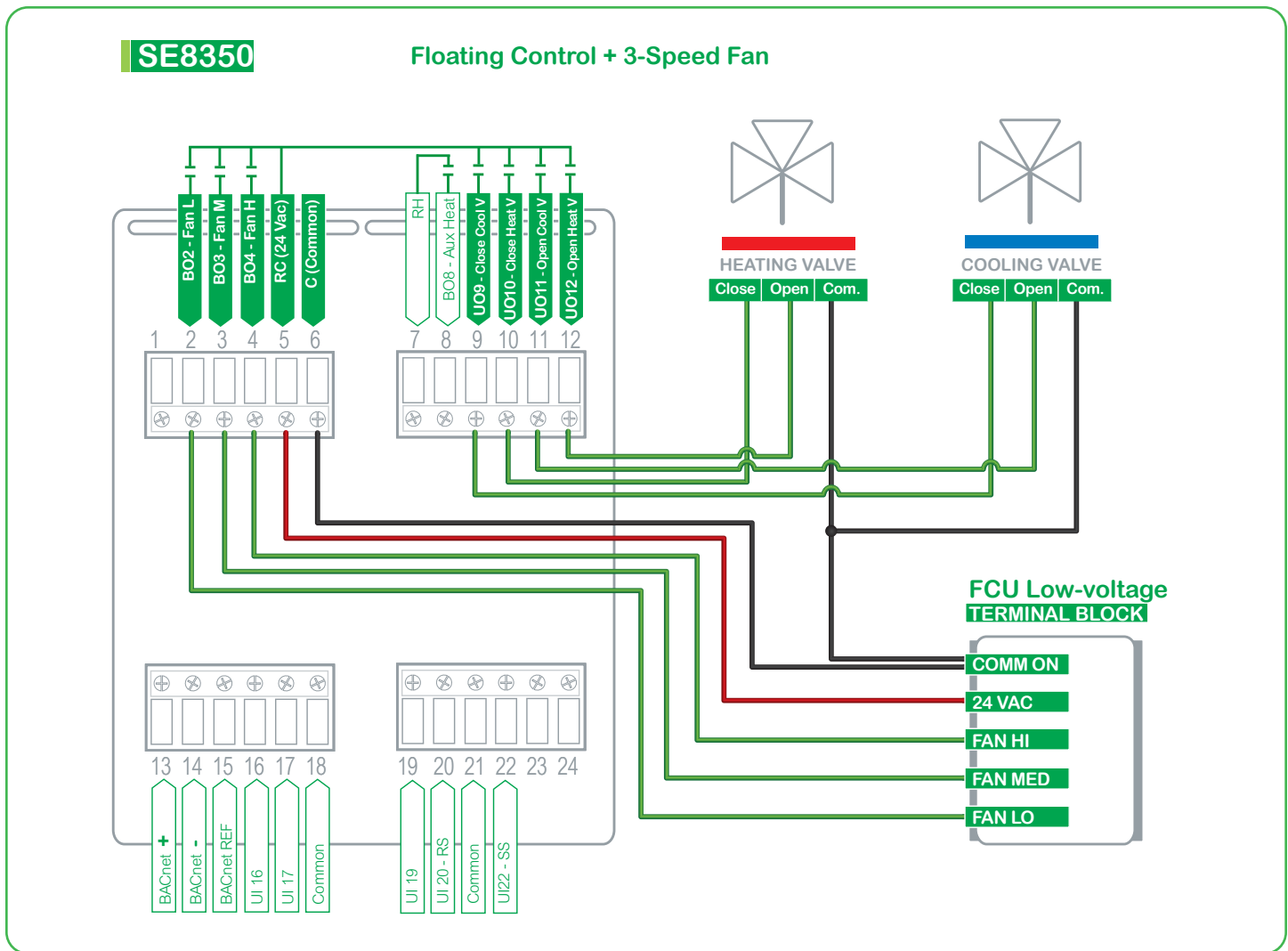

## Sequence of Operation and Wiring

### Occupied Mode

Setpoints revert to those defined by occupied cooling and heating.

### Stand-by Mode (only available when PIR motion detector sensor is used)

Setpoints revert to those defined by stand-by cooling and heating.

### Unoccupied Mode

Setpoints revert to those defined by unoccupied heating and cooling.

### Occupied Override Mode

System reverts to occupied mode for duration determined by "ToccTime" parameter.

### On Call for Cool

Cooling valve opens to maintain room temperature. Heating valve closes.

### On Call for Heat

Heating valve opens to maintain room temperature. Cooling valve closes.

### On Demand for Dehumidification

Dehumidification is achieved via cooling coil using heating coil for reheat if necessary.

Dehumidification is only allowed in COOL mode, or if cooling is enabled in AUTO mode.

Dehumidification is disabled if room temperature falls below low ambient lockout temperature, which is the cooling setpoint minus the configuration defined deadband value.

Reheat disabled if cooling demand reaches 100%.

### 3 speed Fan Operation

#### System Off

BO2, BO3 and BO4 are not energized

#### System On: (Fan modes)

- BO2 is energized.
- BO3 is energized
- BO4 is energized.
- Auto: When there is no demand, BO2, BO3 and BO4 are not energized. On demand, system will automatically switch "On" low (BO2), medium (BO3) or high (BO4) speed.

### Options

- Wireless adapter modules for BACnet models are available. (see Appendix B for network wiring).
- Remote wall mount or duct sensor ready.
- Can be configured for 2-pipe systems with changeover.
- 3 universal inputs can be used and configured for advanced functionality as required by the application.
- Universal input can be configured for changeover sensor.

**SpaceLogic SER8350/SE8350 [ Application Guide ]**

**SE8350 HEATING/COOLING 4-PIPE FAN COIL UNIT WITH 3-SPEED FAN, 0-10 VDC ANALOG VALVES AND DEHUMIDIFICATION SEQUENCE FOR LOW VOLTAGE**

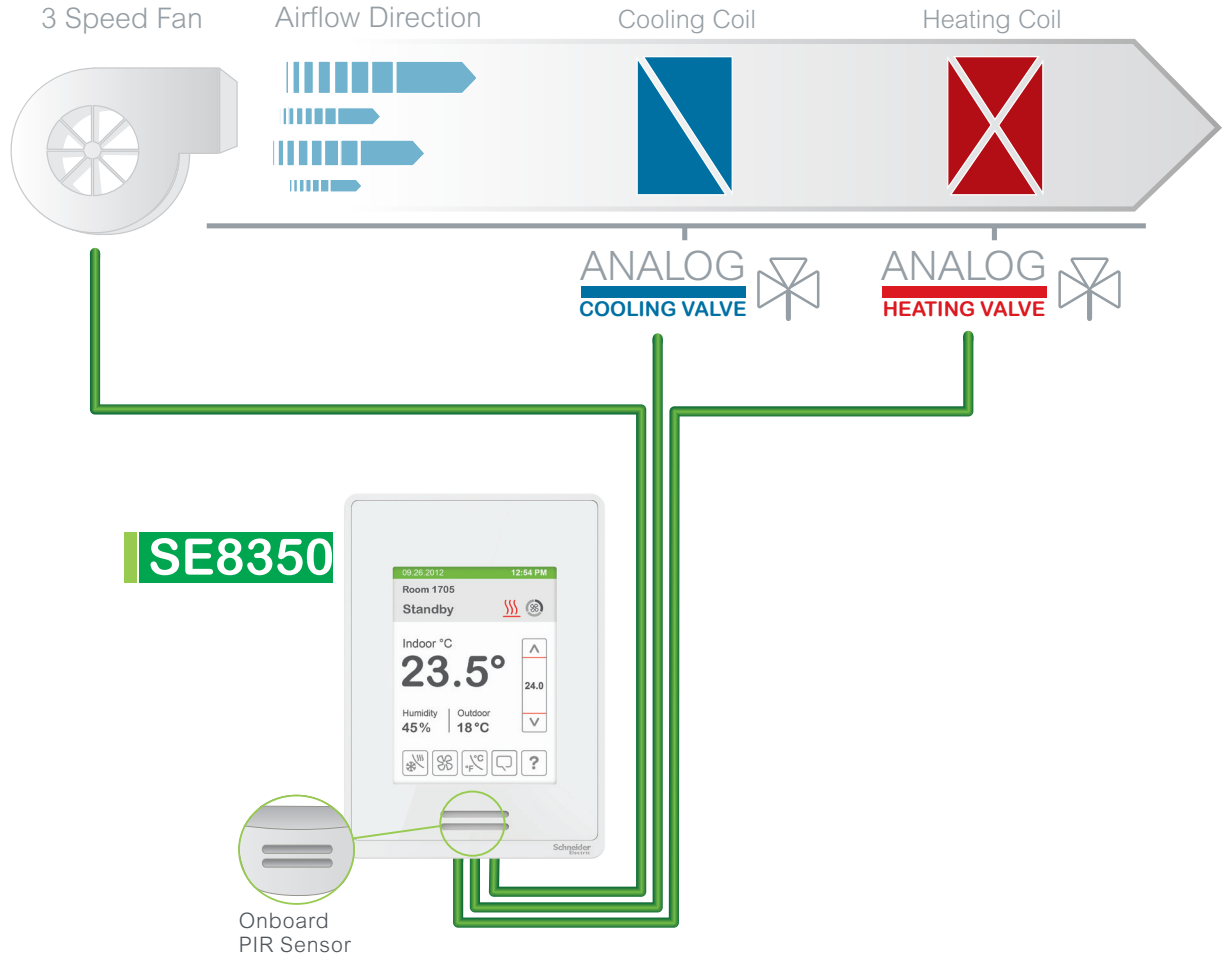

Configuration Parameter Name	Configuration Settings
Fan type	3 speed
Ctrl. type out1	0-10V DA or 0-10V RA (Analog)
Ctrl. type out2	Same as 1
Fan menu	L-M-H-A
No. of pipes	4
Operation sequence	Cool/Heat

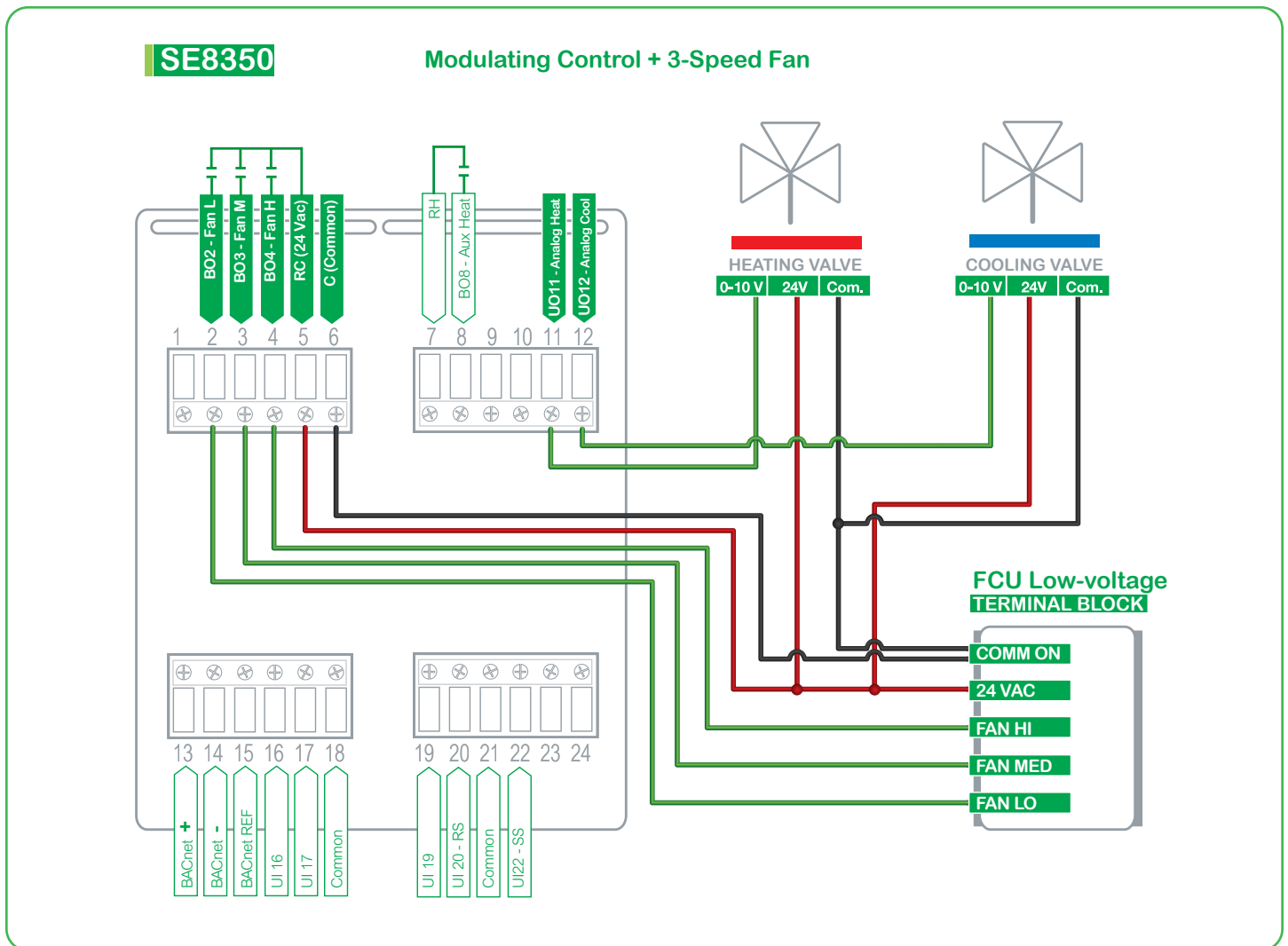

## Sequence of Operation and Wiring

### Occupied Mode

Setpoints revert to those defined by occupied cooling and heating.

### Stand-by Mode (only available when PIR motion detector sensor is used)

Setpoints revert to those defined by stand-by cooling and heating.

### Unoccupied Mode

Setpoints revert to those defined by unoccupied heating and cooling.

### Occupied Override Mode

System reverts to occupied mode for duration determined by "ToccTime" parameter.

### On Call for Cool

Cooling valve opens to maintain room temperature. Heating valve closes. Dehumidification enabled.

### On Call for Heat

Heating valve opens to maintain room temperature. Cooling valve closes. Dehumidification disabled.

### On Demand for Dehumidification

Dehumidification is achieved via cooling coil using heating coil for reheat if necessary.

Dehumidification only allowed in COOL mode, or if cooling is enabled in AUTO mode.

Dehumidification disabled if room temperature falls below low ambient lockout temperature, which is cooling setpoint minus configuration defined deadband value.

Reheat disabled if cooling demand reaches 100%.

### 3 speed Fan Operation

#### System Off

BO2, BO3 and BO4 are not energized

#### System On: (Fan modes)

- BO2 is energized.
- BO3 is energized
- BO4 is energized.
- Auto: When there is no demand, BO2, BO3 and BO4 are not energized. On demand, system will automatically switch "On" low (BO2), medium (BO3) or high (BO4) speed.

#### Options

- Wireless adapter modules for BACnet models are available. (see Appendix B for network wiring).
- Remote wall mount or duct sensor ready.
- Can be configured for 2-pipe systems.
- 3 universal inputs can be used and configured for advanced functionality as required by the application.
- Universal input can be configured for changeover sensor.

SE8350 HEATING/COOLING 4-PIPE FAN COIL UNIT WITH 3-SPEED FAN, 2-POSITION VALVES AND DEHUMIDIFICATION SEQUENCE FOR LOW VOLTAGE

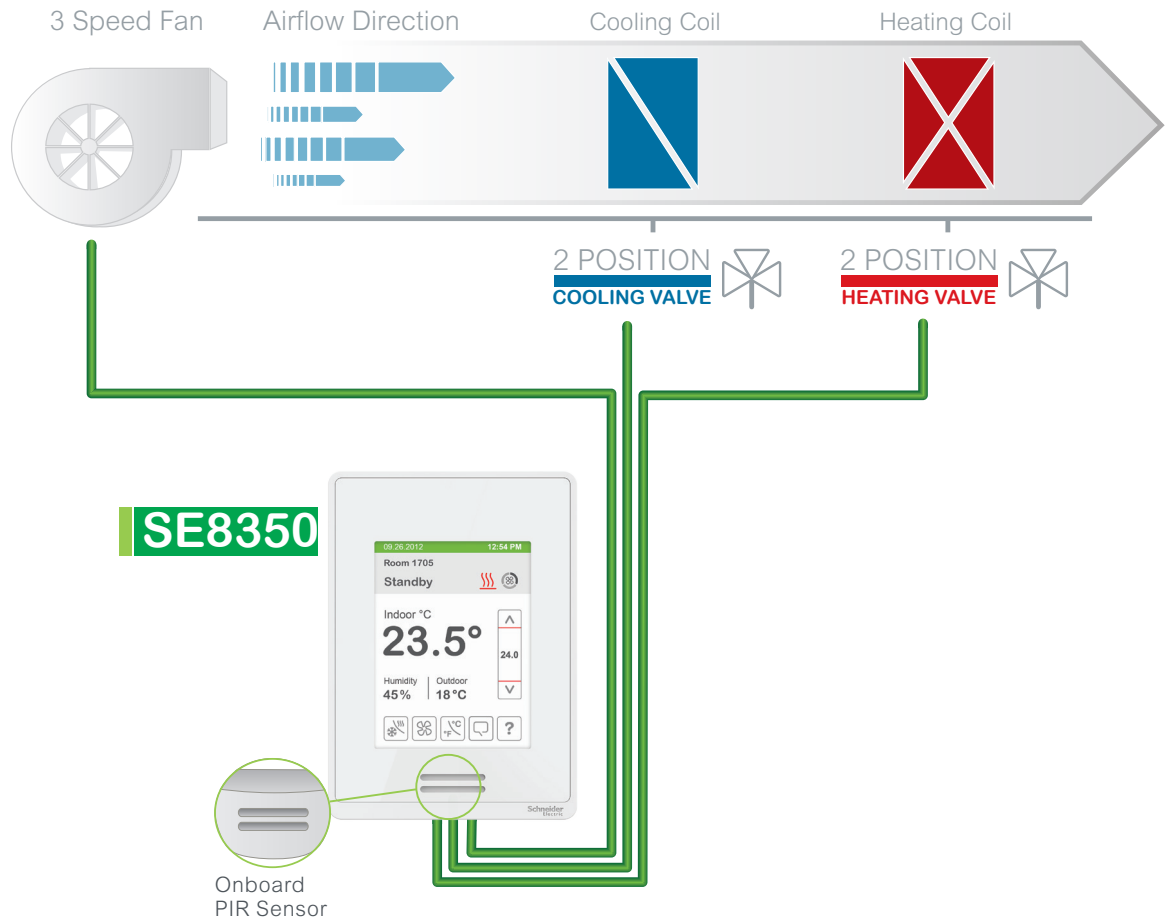

Configuration Parameter Name	Configuration Settings
Fan type	3 speed
Fan menu	L-M-H-A
Ctrl. type out1	On/Off
Ctrl. type out2	Same as 1
No. of pipes	4
Operation sequence	Cool/Heat

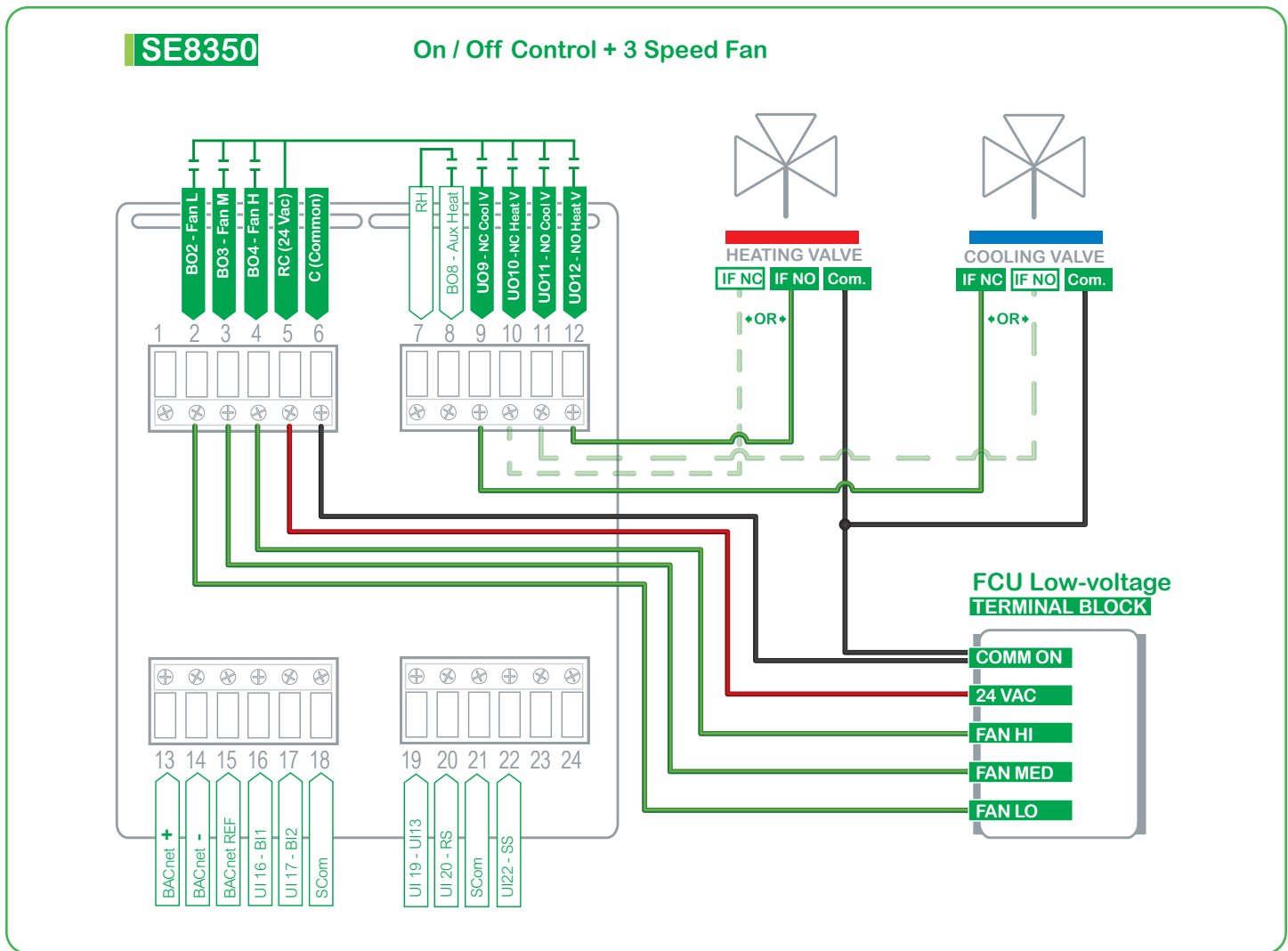

## Sequence of Operation and Wiring

### Occupied Mode

Setpoints revert to those defined by occupied cooling and heating.

### Stand-by Mode (only available when PIR motion detector sensor is used)

Setpoints revert to those defined by stand-by cooling and heating.

### Unoccupied Mode

Setpoints revert to those defined by unoccupied heating and cooling.

### Occupied Override Mode

System reverts to occupied mode for duration determined by "ToccTime" parameter.

### On Call for Cool

Cooling valve opens to maintain room temperature. Heating valve closes. Dehumidification enabled.

### On Call for Heat

Heating valve opens to maintain room temperature. Cooling valve closes. Dehumidification disabled.

### On Demand for Dehumidification

Dehumidification is achieved via cooling coil using heating coil for reheat if necessary.

Dehumidification only allowed in COOL mode, or if cooling is enabled in AUTO mode.

Dehumidification disabled if room temperature falls below low ambient lockout temperature, which is cooling setpoint minus configuration defined deadband value.

Reheat disabled if cooling demand reaches 100%.

### 3 speed Fan Operation

#### System Off

BO2, BO3 and BO4 are not energized

#### System On: (Fan modes)

- BO2 is energized.
- BO3 is energized
- BO4 is energized.
- Auto: When there is no demand, BO2, BO3 and BO4 are not energized. On demand, system will automatically switch "On" low (BO2), medium (BO3) or high (BO4) speed.

### Options

- Wireless adapter modules for BACnet models are available. (see Appendix B for network wiring).
- Models available with factory installed PIR sensor.
- Remote wall mount or duct sensor ready.
- Can be configured for 2-pipe systems.
- 3 universal inputs can be used and configured for advanced functionality as required by the application.
- Universal input can be configured for changeover sensor.

**SpaceLogic** SER8350/SE8350 [ Application Guide ]

SE8350 COOLING ONLY 2-PIPE FAN COIL UNIT WITH SINGLE SPEED FAN, 2-POSITION COOLING VALVE AND FRESH AIR DAMPER FOR LOW VOLTAGE

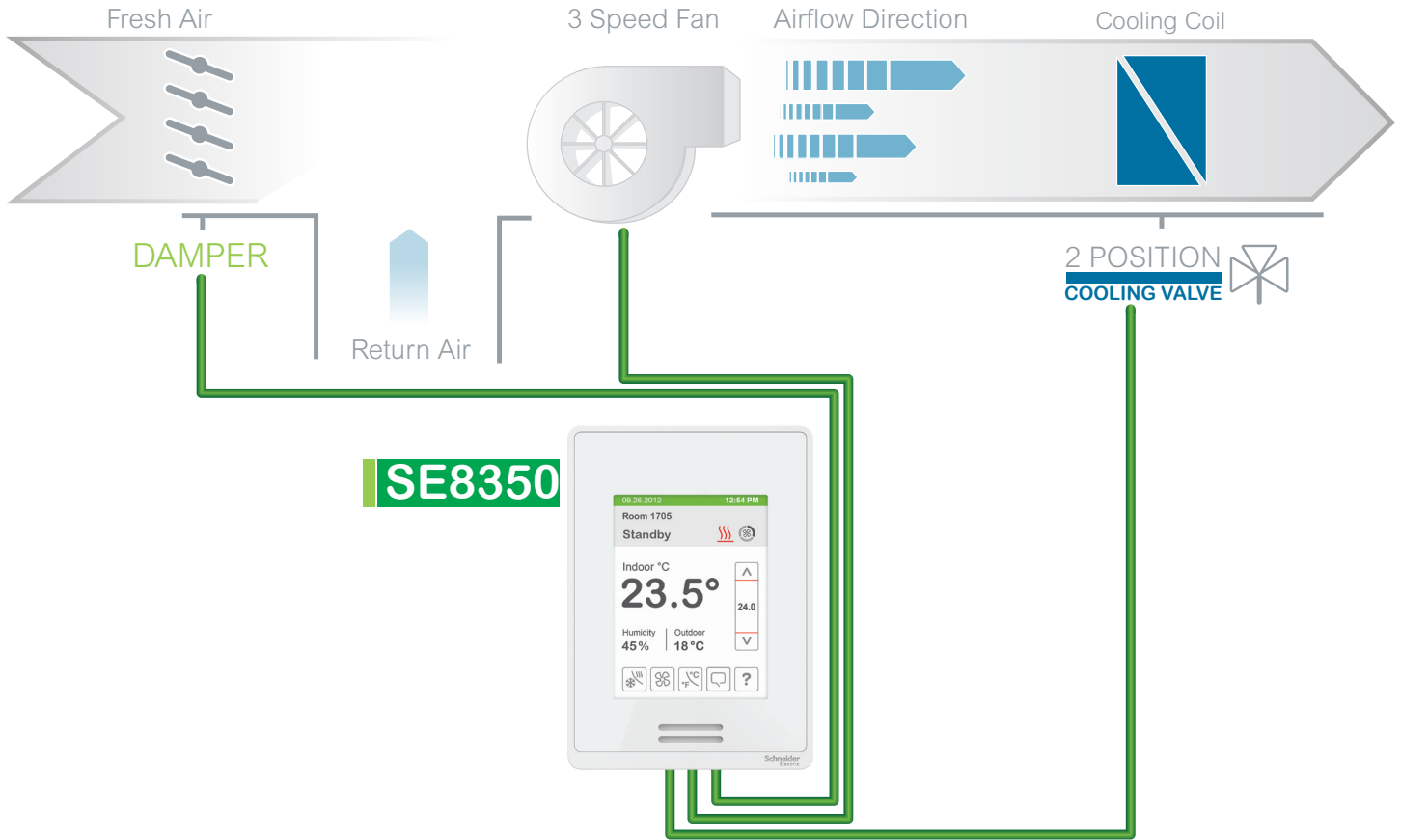

Configuration Parameter Name	Configuration Settings
Fan type	3 speed
Fan menu	On-Auto
Ctrl. type out1	On/Off
Ctrl. type out2	Same as 1
BO8 aux. config	Aux NO
No. of pipes	2
Operation sequence	Cool only

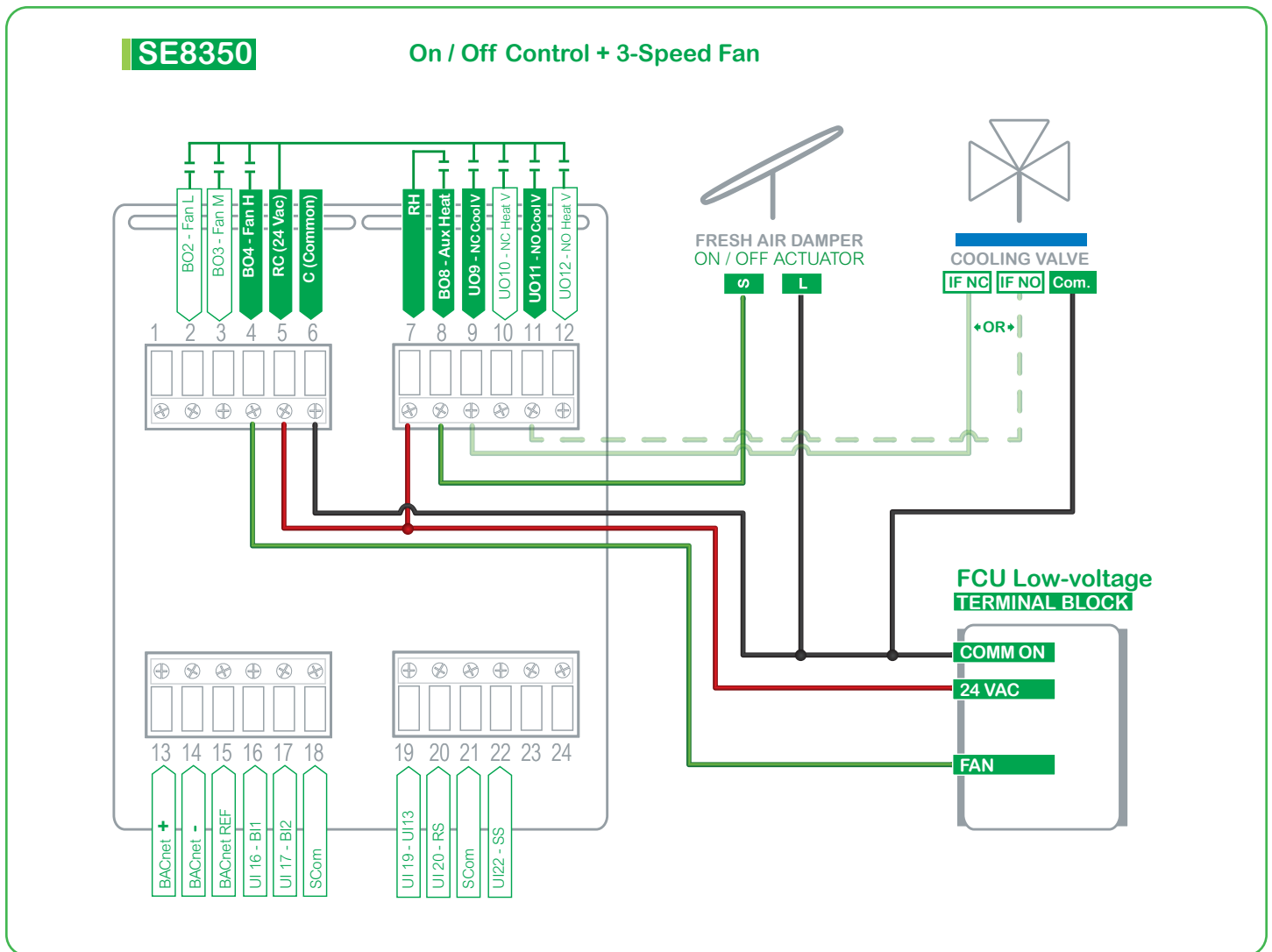

## Sequence of Operation and Wiring

### Occupied Mode

Setpoints revert to those defined by occupied cooling and heating. The auxiliary contact closes forcing fresh air damper to open.

### Stand-by Mode (only available when PIR motion detector sensor is used)

Setpoints revert to those defined by stand-by cooling and heating.

### Unoccupied Mode

Setpoints revert to those defined by unoccupied heating and cooling. The auxiliary contact opens causing fresh air damper to close completely.

### Occupied Override Mode

System reverts to occupied mode for duration determined by "ToccTime" parameter. The auxiliary contact closes forcing fresh air damper to open.

### On Call for Cool

Cooling valve opens.

### On Call for Heat

Cooling valve closes.

## Options

- Wireless adapter modules are available. (see Appendix B for network wiring).
- Remote wall mount or duct sensor ready.
- Can be configured for 4-pipe systems.
- 3 universal inputs can be used and configured for advanced functionality as required by the application.
- Can be configured for two speed or three speed fan control.

### 1 speed Fan Operation

#### System Off

BO2, BO3 and BO4 are not energized

#### System On: (Fan modes)

- On: BO4 is energized.
- Auto: When there is no demand, BO4 is not energized. On demand, BO4 will be energized.

## SpaceLogic SER8350/SE8350 [ Application Guide ]

### SE8350 COOLING WITH REHEAT 4-PIPE FAN COIL UNIT WITH 3-SPEED FAN, ANALOG COOLING VALVE AND N.C. ON/OFF HEATING VALVE FOR LOW VOLTAGE

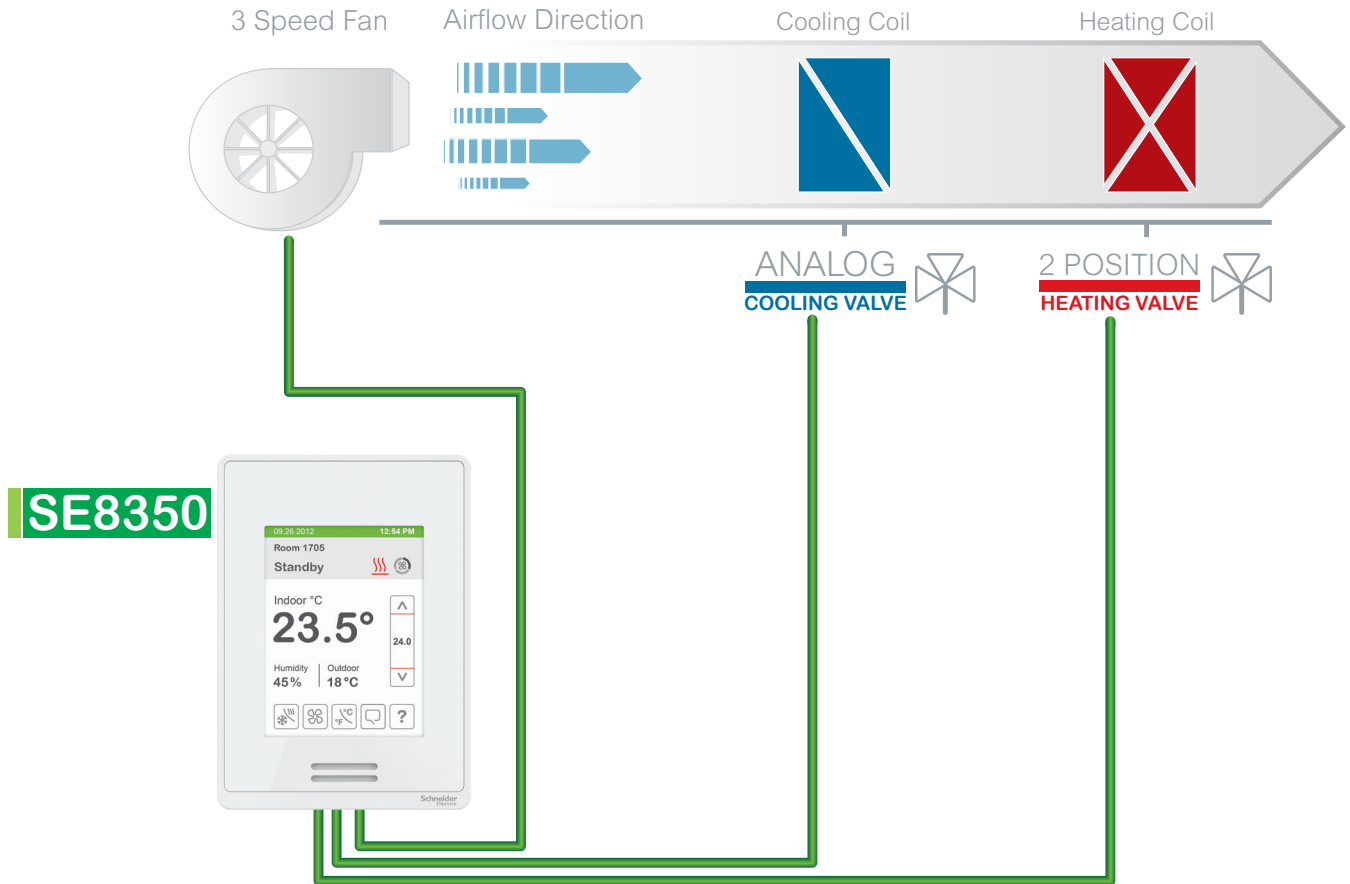

Configuration Parameter Name	Configuration Settings
Fan type	3 speed
Ctrl. type out1	0-10V DA or 0-10V RA (Analog)
Ctrl. type out2	Same as 1
Fan menu	L-M-H-A
BO8 out time	15 min.
BO8 aux. config	Reheat NO
No. of pipes	2 (Configured for 2-Pipe application with reheat)
Operation sequence	Cool-rht

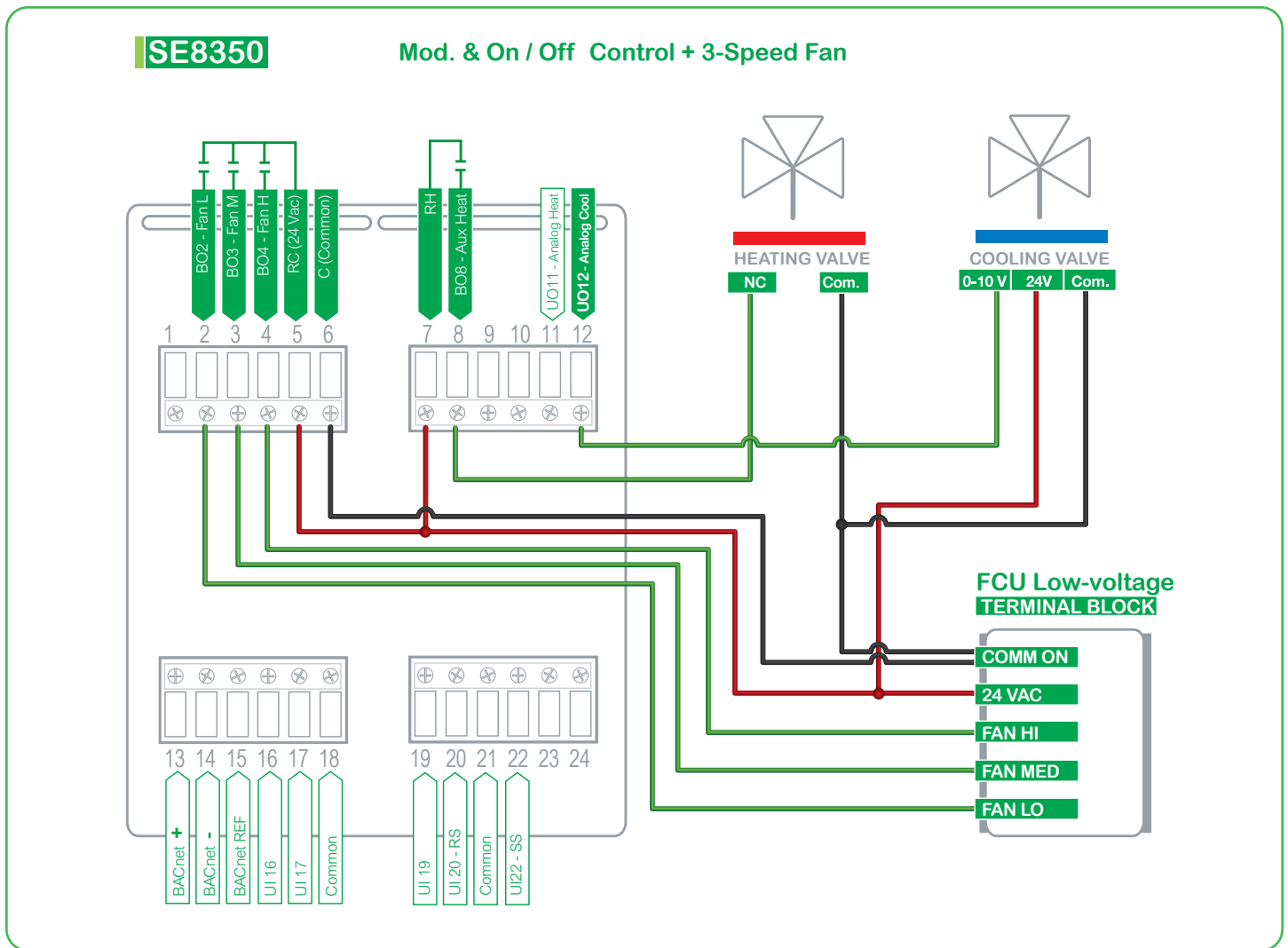

## Sequence of Operation and Wiring

### Occupied Mode

Setpoints revert to those defined by occupied cooling and heating.

### Stand-by Mode (only available when PIR motion detector sensor is used)

Setpoints revert to those defined by stand-by cooling and heating.

### Unoccupied Mode

Setpoints revert to those defined by unoccupied heating and cooling.

### Occupied Override Mode

System reverts to occupied mode for duration determined by "ToccTime" parameter.

### On Call for Cool

Analog valve starts modulating based on cooling demand.

### On Call for Heat

Heating valve opens.

## Options

- Wireless adapter modules are available. (see Appendix B for network wiring).
- Remote wall mount or duct sensor ready.
- Can be configured for 2-pipe systems.
- Can be configured to single or two speed fan.
- 3 universal inputs can be used and configured for advanced functionality as required by the application.

## 3 speed Fan Operation

### System Off

BO2, BO3 and BO4 are not energized

### System On: (Fan modes)

- BO2 is energized.
- BO3 is energized
- BO4 is energized.
- Auto: When there is no demand, BO2, BO3 and BO4 are not energized. On demand, system will automatically switch "On" low (BO2), medium (BO3) or high (BO4) speed.

**SpaceLogic SER8350/SE8350 [ Application Guide ]**

**SE8350 COOLING ONLY 2-PIPE FAN COIL UNIT WITH 3-SPEED FAN AND 0-10 VDC ANALOG COOLING VALVE FOR LOW VOLTAGE**

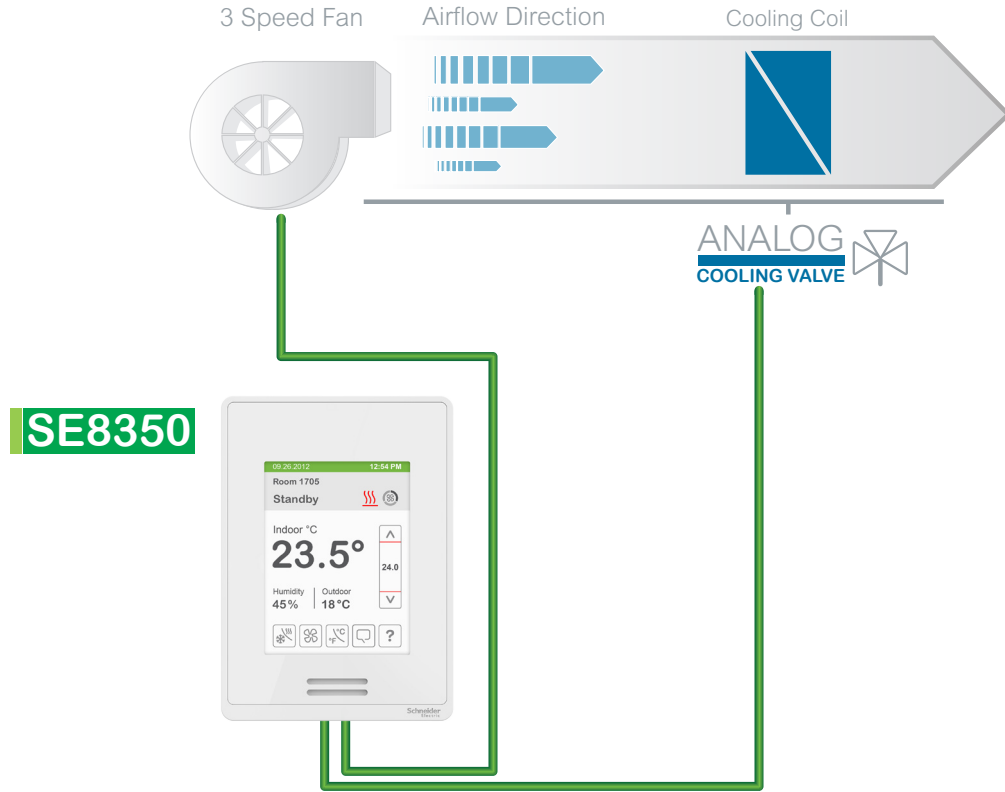

Configuration Parameter Name	Configuration Settings
Fan type	3 speed
Ctrl. type out1	0-10V DA or 0-10V RA (Analog)
Ctrl. type out2	Same as 1
Fan menu	L-M-H-A
No. of pipes	2
Operation sequence	Cool only

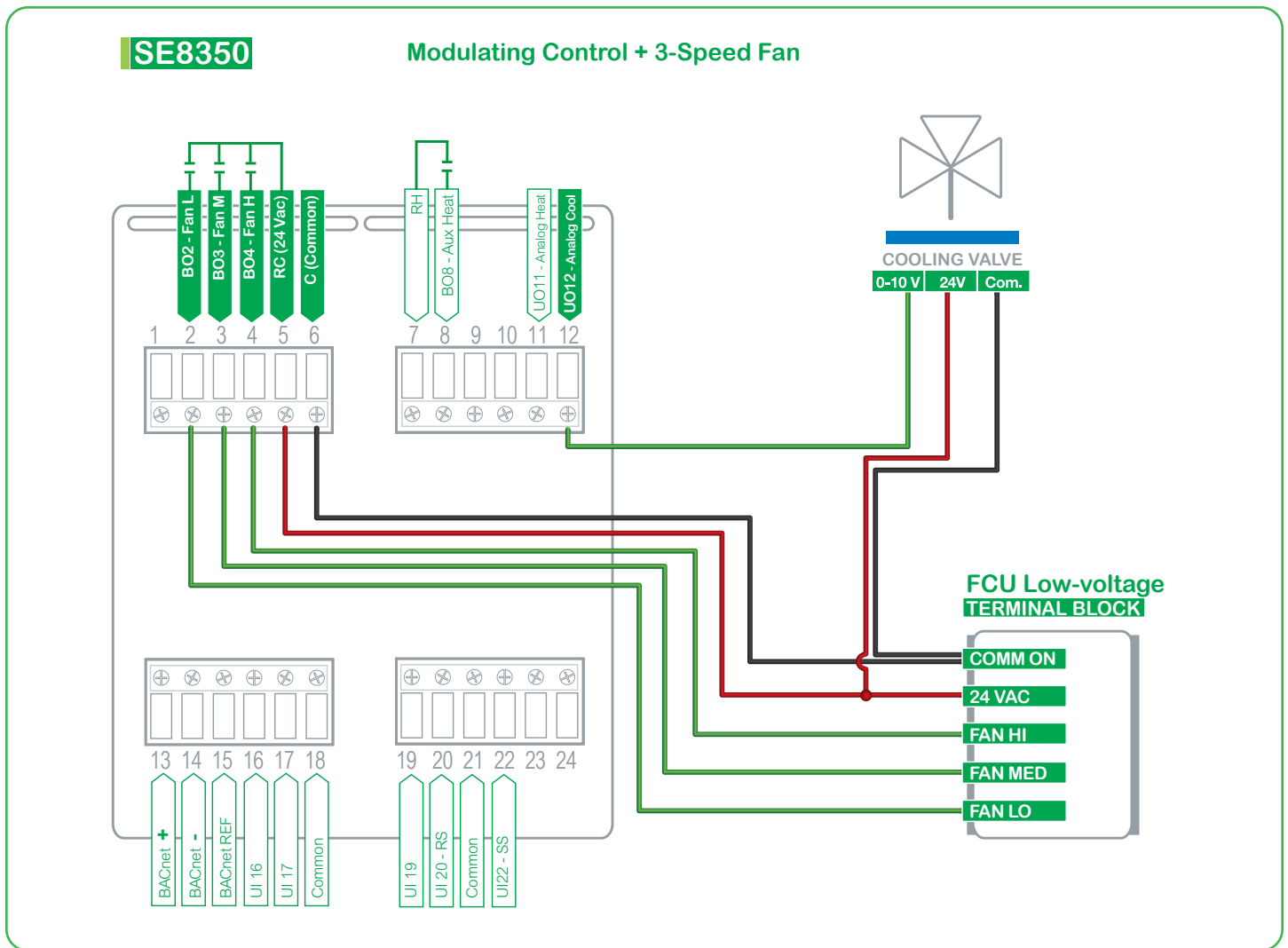

## Sequence of Operation and Wiring

### Occupied Mode

Setpoints revert to those defined by occupied cooling and heating.

### Stand-by Mode (only available when PIR motion detector sensor is used)

Setpoints revert to those defined by stand-by cooling and heating.

### Unoccupied Mode

Setpoints revert to those defined by unoccupied heating and cooling.

### Occupied Override Mode

System reverts to occupied mode for duration determined by "ToccTime" parameter.

### On Call for Cool

Analog valve modulates allowing cool air to flow to reach setpoint.

### On Call for Heat

Valve closes.

## Options

- Wireless adapter modules are available. (see Appendix B for network wiring).
- Remote wall mount or duct sensor ready.
- Can be configured for 4-pipe systems.
- 3 universal inputs can be used and configured for advanced functionality as required by the application.
- Can be configured to two or three speed fan.

## 3 speed Fan Operation

### System Off

BO2, BO3 and BO4 are not energized

### System On: (Fan modes)

- BO2 is energized.
- BO3 is energized
- BO4 is energized.
- Auto: When there is no demand, BO2, BO3 and BO4 are not energized. On demand, system will automatically switch "On" low (BO2), medium (BO3) or high (BO4) speed.

SE8350 COOLING WITH REHEAT 2-PIPE FAN COIL UNIT WITH 3-SPEED FAN, 2-POSITION VALVE AND ELECTRIC REHEAT FOR LOW VOLTAGE

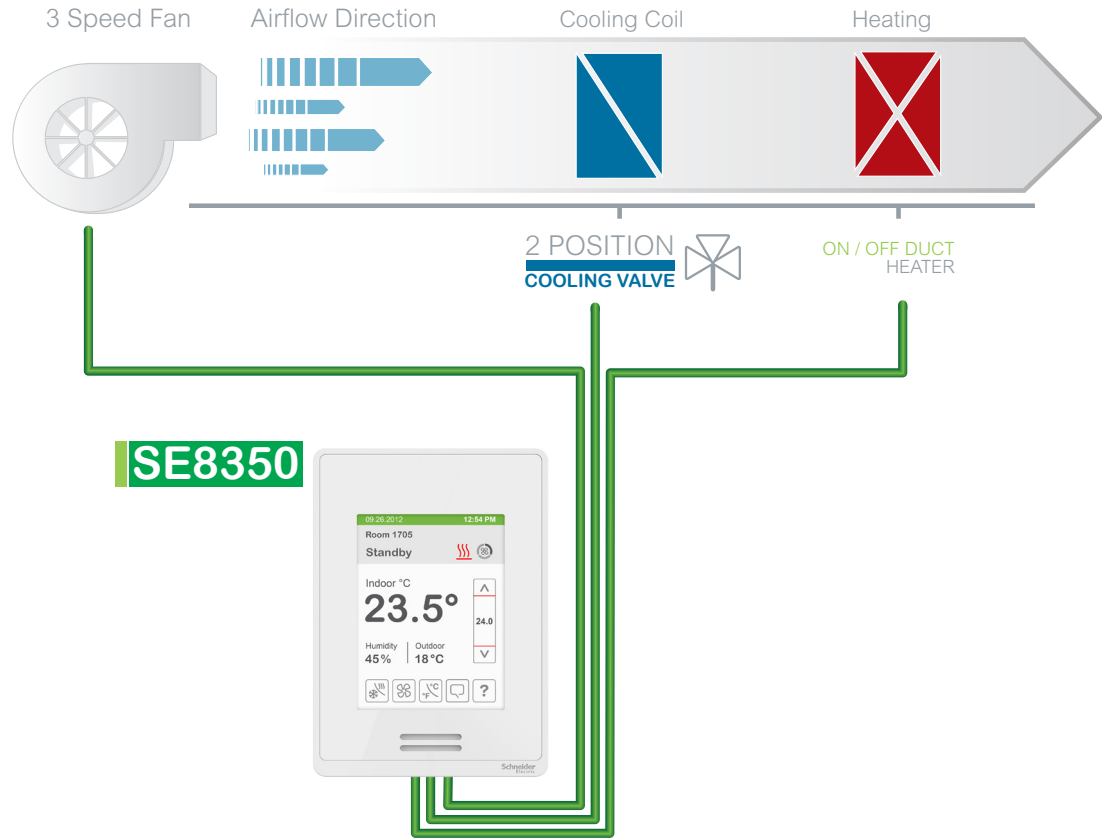

Configuration Parameter Name	Configuration Settings
Fan type	3 speed
Fan menu	L-M-H-A
Ctrl. type out1	On/Off
Ctrl. type out2	Same as 1
BO8 out time	15 min.
BO8 aux. config	Reheat NO
No. of pipes	2
Operation sequence	Cool-rht

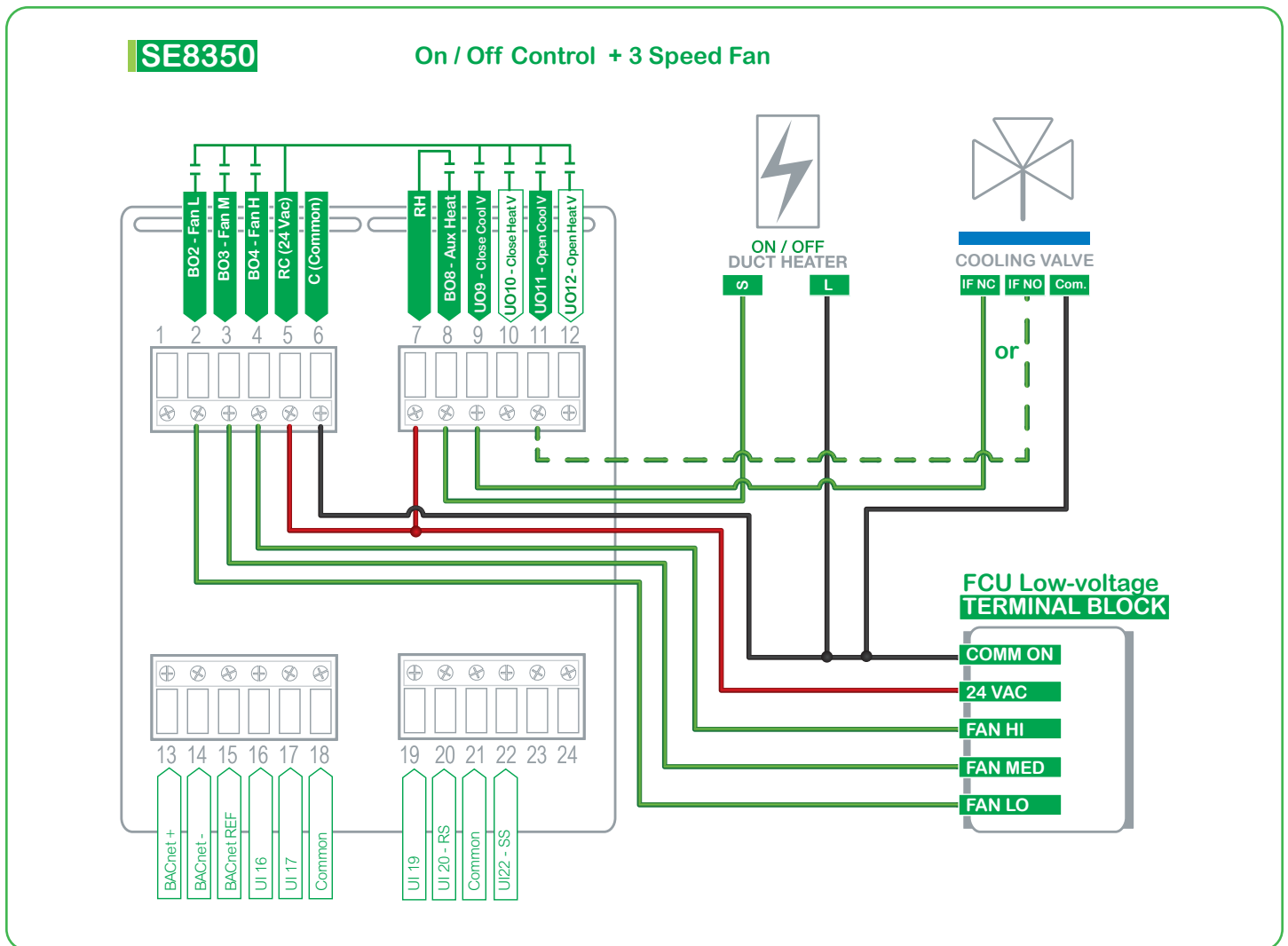

## Sequence of Operation and Wiring

### Occupied Mode

Setpoints revert to those defined by occupied cooling and heating. The changeover sensor sends supply air temperature to controller.

### Stand-by Mode (only available when PIR motion detector sensor is used)

Setpoints revert to those defined by stand-by cooling and heating.

### Unoccupied Mode

Setpoints revert to those defined by unoccupied heating and cooling.

### Occupied Override Mode

System reverts to occupied mode for duration determined by "ToccTime" parameter.

### On Call for Cool

Cooling valve opens. Electric heat stays Off.

### On Call for Heat

Valve closes. Electric heat activates.

## Options

- Wireless adapter modules for BACnet models are available. (see Appendix B for network wiring).
- Remote wall mount or duct sensor ready.
- Can be configured for 4-pipe systems.
- 3 universal inputs can be used and configured for advanced functionality as required by the application.
- Can be configured to single or two speed fan.

## 3 speed Fan Operation

### System Off

BO2, BO3 and BO4 are not energized

### System On: (Fan modes)

- BO2 is energized.
- BO3 is energized
- BO4 is energized.
- Auto: When there is no demand, BO2, BO3 and BO4 are not energized. On demand, system will automatically switch "On" low (BO2), medium (BO3) or high (BO4) speed.

**SpaceLogic**  
**SE8350 ECM Fan**

## SE8350

## ECM FAN APPLICATIONS

System	Fan	Cooling	Heating	Other
4 pipes	ECM	Tri-state valve actuator	Tri-state valve actuator	Door and motion detect + dehumidification
4 pipes	ECM	0-10 Vdc valve actuator	0-10 Vdc valve actuator	Motion detect + dehumidification
4 pipes	ECM	2 positions valve actuator	2 positions valve actuator	Motion detect + dehumidification
4 pipes	ECM	0-10 Vdc valve actuator	2 positions valve actuator reheat	---
2 pipes	ECM	0-10 Vdc valve actuator	None	---
2 pipes	ECM	0-10 Vdc valve actuator	Electric reheat	---

**SpaceLogic** SER8350/SE8350 [ Application Guide ]

SE8350 HEATING/COOLING 4-PIPE FAN COIL UNIT WITH ECM FAN, TRI-STATE FLOATING VALVES AND DEHUMIDIFICATION SEQUENCE FOR LOW VOLTAGE

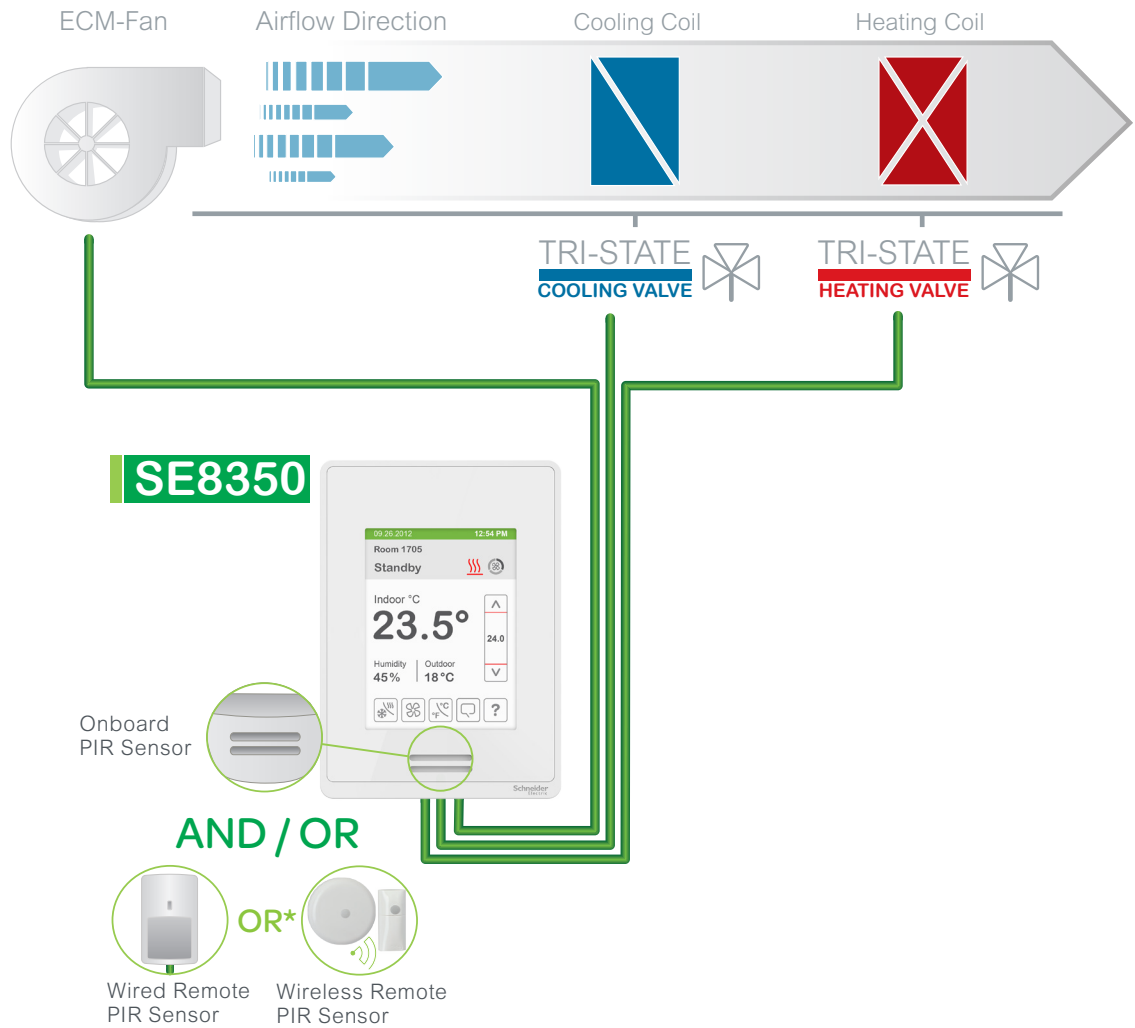

Configuration Parameter Name	Configuration Settings
Fan type	ECM
Fan menu	L-M-H-A
Ctrl. type out1	Floating
Ctrl. type out2	Same as 1
UI16 config	Motion NO or Motion NC (remote PIR sensor only)
UI17 config	Door Dry
No. of pipes	4
Operation sequence	Cool/Heat

\* Wired remote sensor cannot be used at the same time as wireless remote sensor(s).

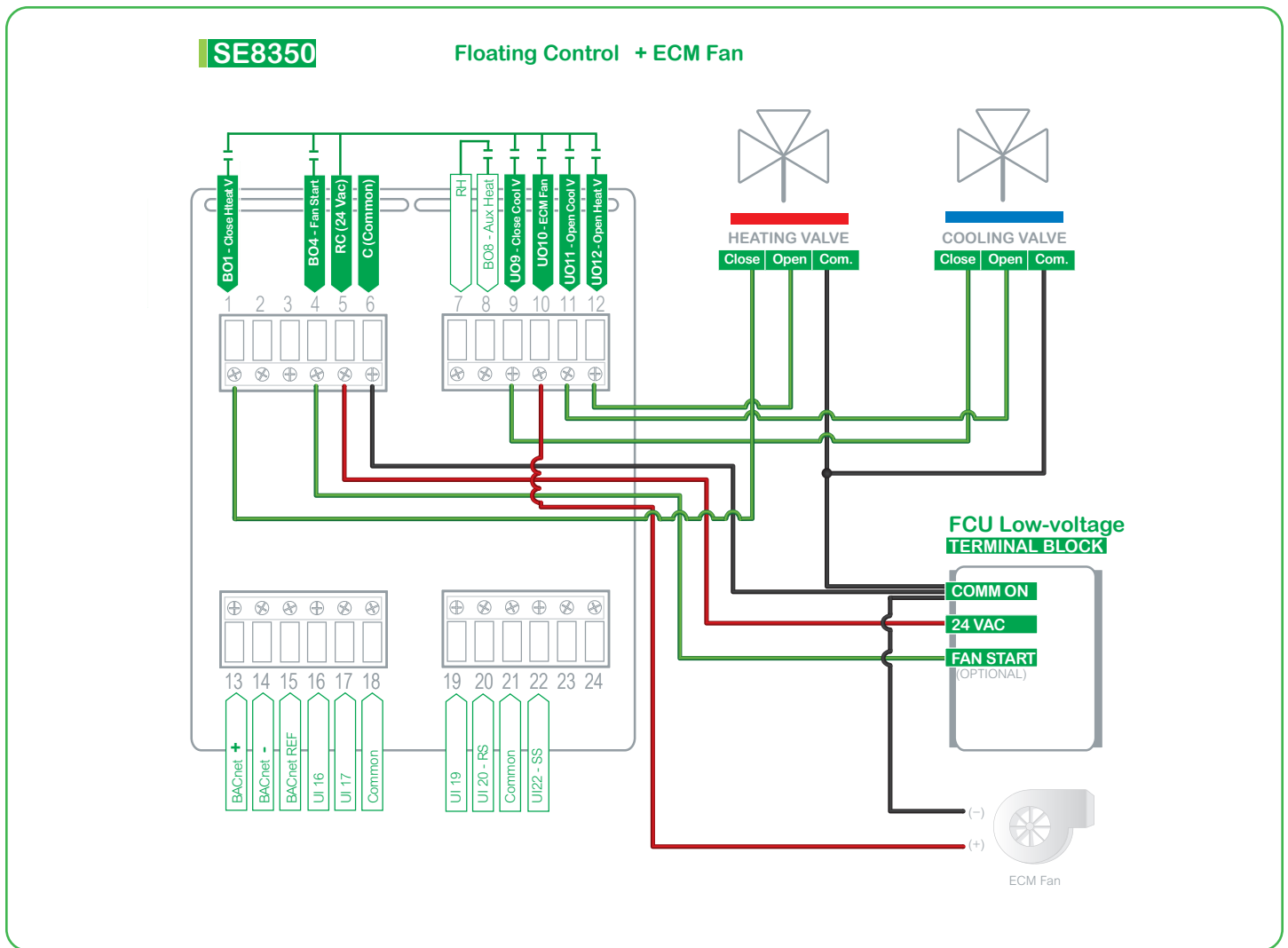

## Sequence of Operation and Wiring

### Occupied Mode

Setpoints revert to those defined by occupied cooling and heating.

### Stand-by Mode (only available when PIR motion detector sensor is used)

Setpoints revert to those defined by stand-by cooling and heating.

### Unoccupied Mode

Setpoints revert to those defined by unoccupied heating and cooling.

### Occupied Override Mode

System reverts to occupied mode for duration determined by "TocTime" parameter.

### On Call for Cool

Cooling valve opens to maintain room temperature. Heating valve closes.

### On Call for Heat

Heating valve opens to maintain room temperature. Cooling valve closes.

### On Demand for Dehumidification

Dehumidification is achieved via cooling coil using heating coil for reheat if necessary.

Dehumidification is only allowed in COOL mode, or if cooling is enabled in AUTO mode.

Dehumidification is disabled if room temperature falls below low ambient lockout temperature, which is the cooling setpoint minus the configuration defined deadband value.

Reheat disabled if cooling demand reaches 100%.

## ECM Fan Operation

### System Off

- UO10 = 0 Vdc and BO4 (fan start) is not energized

### System On: (Fan modes)

- Low: UO10 = 2.2 Vdc (adjustable from configuration menu) and BO4 “fan start” is energized.
- Med: UO10 = 6.0 Vdc (adjustable from configuration menu) and BO4 “fan start” is energized.
- High: UO10 = 8.6 Vdc (adjustable from configuration menu) and BO4 “fan start” is energized.
- Auto: When there is no demand, UO10 = 0 Vdc and BO4 “fan start” is not energized. On demand, system will modulate from “low” to “high” voltages (adjustable from configuration menu) and BO4 “fan start” is energized.

## Options

- Wireless adapter modules are available. (see Appendix B for network wiring).
- Remote wall mount or duct sensor ready.
- Can be configured for 2-pipe systems with changeover.
- 3 universal inputs can be used and configured for advanced functionality as required by the application.
- Universal input can be configured for changeover sensor.

SE8350 HEATING/COOLING 4-PIPE FAN COIL UNIT WITH ECM FAN, 0-10 VDC ANALOG VALVES AND DEHUMIDIFICATION SEQUENCE FOR LOW VOLTAGE

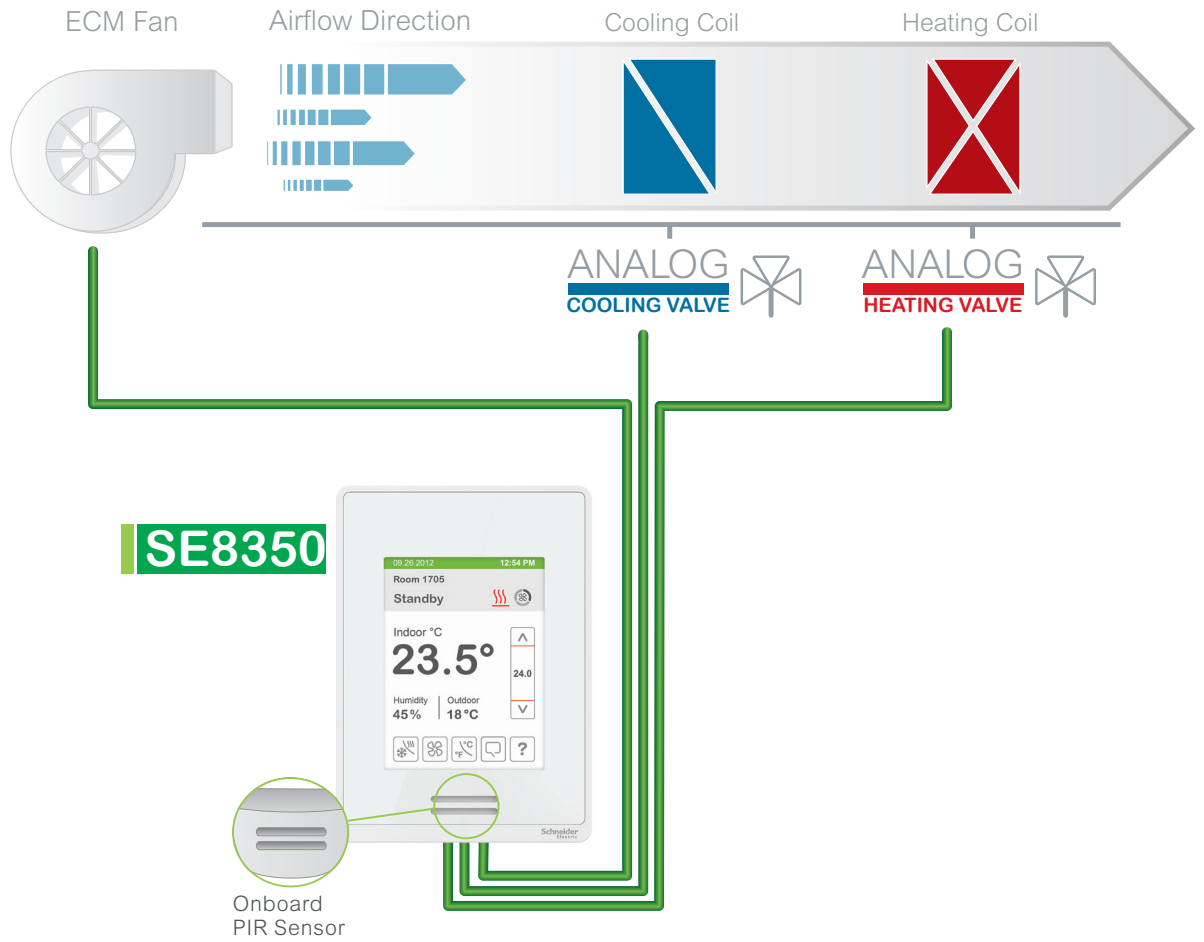

Configuration Parameter Name	Configuration Settings
Fan cotrol	ECM
Ctrl. type out1	0-10V DA or 0-10V RA (Analog)
Ctrl. type out2	Same as 1
Fan menu	L-M-H-A
No. of pipes	4
Operation sequence	Cool/Heat

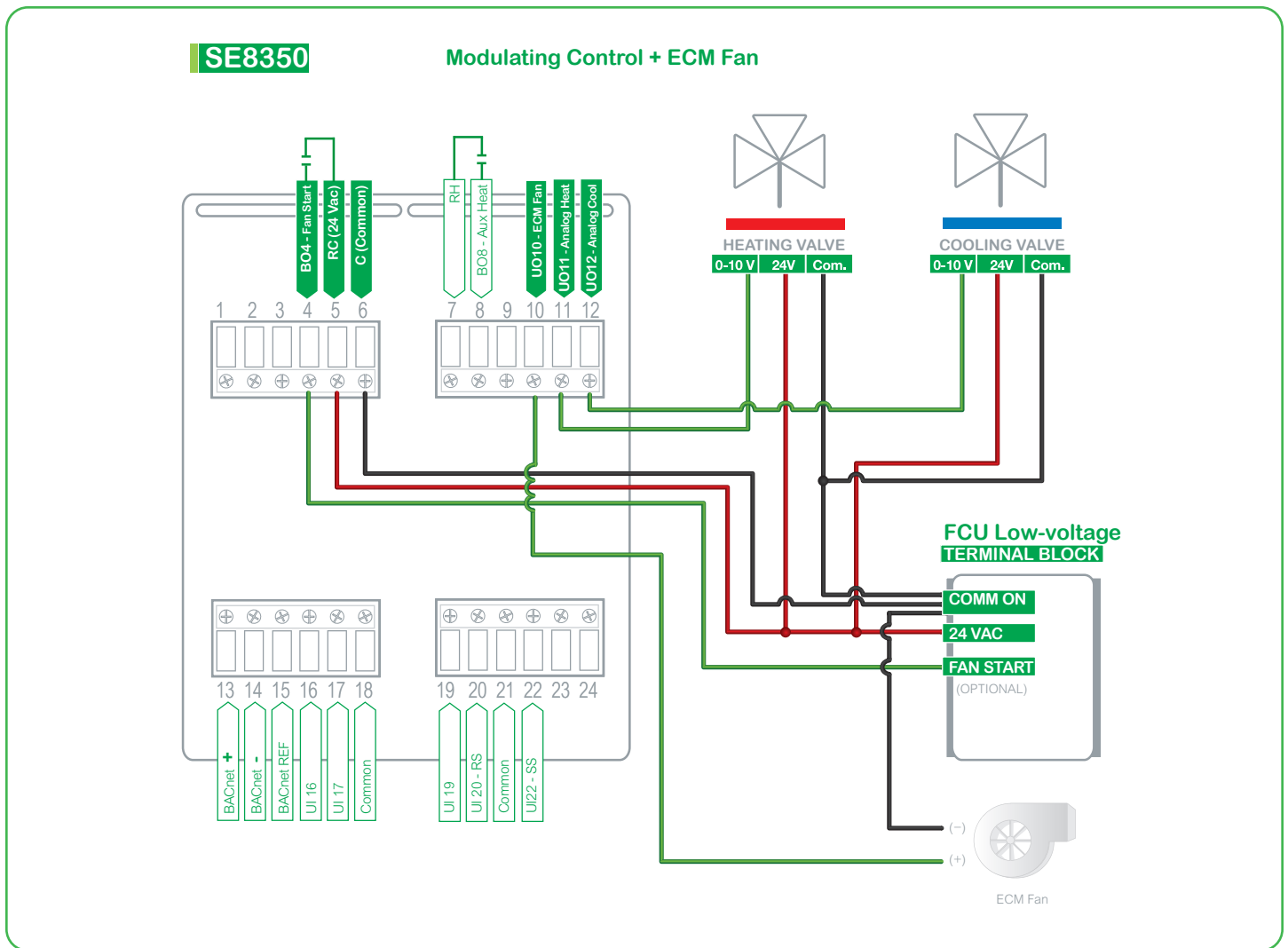

## Sequence of Operation and Wiring

### Occupied Mode

Setpoints revert to those defined by occupied cooling and heating. The changeover sensor sends supply air temperature to controller.

### Stand-by Mode (only available when PIR motion detector sensor is used)

Setpoints revert to those defined by stand-by cooling and heating.

### Unoccupied Mode

Setpoints revert to those defined by unoccupied heating and cooling.

### Occupied Override Mode

System reverts to occupied mode for duration determined by "ToccTime" parameter.

### On Call for Cool

Cooling valve opens to maintain room temperature. Heating valve closes. Dehumidification enabled.

### On Call for Heat

Heating valve opens to maintain room temperature. Cooling valve closes. Dehumidification disabled.

### On Demand for Dehumidification

Dehumidification is achieved via cooling coil using heating coil for reheat if necessary.

Dehumidification only allowed in COOL mode, or if cooling is enabled in AUTO mode.

Dehumidification disabled if room temperature falls below low ambient lockout temperature, which is cooling setpoint minus configuration defined deadband value.

Reheat disabled if cooling demand reaches 100%.

## ECM Fan Operation

### System Off

- UO10 = 0 Vdc and BO4 (fan start) is not energized

### System On: (Fan modes)

- Low: UO10 = 2.2 Vdc (adjustable from configuration menu) and BO4 “fan start” is energized.
- Med: UO10 = 6.0 Vdc (adjustable from configuration menu) and BO4 “fan start” is energized.
- High: UO10 = 8.6 Vdc (adjustable from configuration menu) and BO4 “fan start” is energized.
- Auto: When there is no demand, UO10 = 0 Vdc and BO4 “fan start” is not energized. On demand, system will modulate from “low” to “high” voltages (adjustable from configuration menu) and BO4 “fan start” is energized.

## Options

- Wireless adapter modules are available. (see Appendix B for network wiring).
- Remote wall mount or duct sensor ready.
- Can be configured for 2-pipe systems.
- 3 universal inputs can be used and configured for advanced functionality as required by the application.
- Universal input can be configured for changeover sensor.

**SpaceLogic SER8350/SE8350 [ Application Guide ]**

**SE8350 HEATING/COOLING 4-PIPE FAN COIL UNIT WITH ECM FAN, 2-POSITION VALVES AND DEHUMIDIFICATION SEQUENCE FOR LOW VOLTAGE**

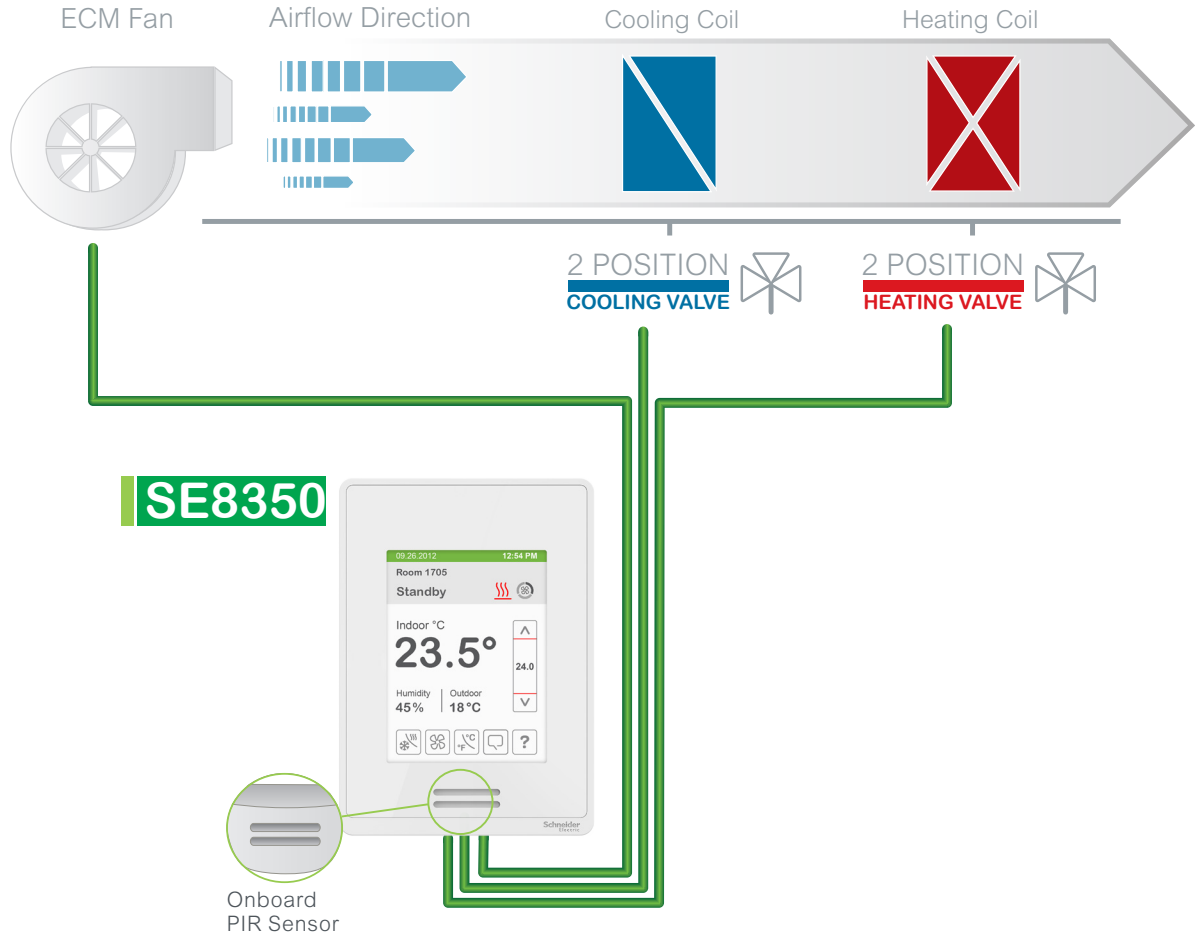

Configuration Parameter Name	Configuration Settings
Fan type	ECM
Fan menu	L-M-H-A
Ctrl. type out1	On/Off
Ctrl. type out2	Same as 1
No. of pipes	4
Operation sequence	Cool/Heat

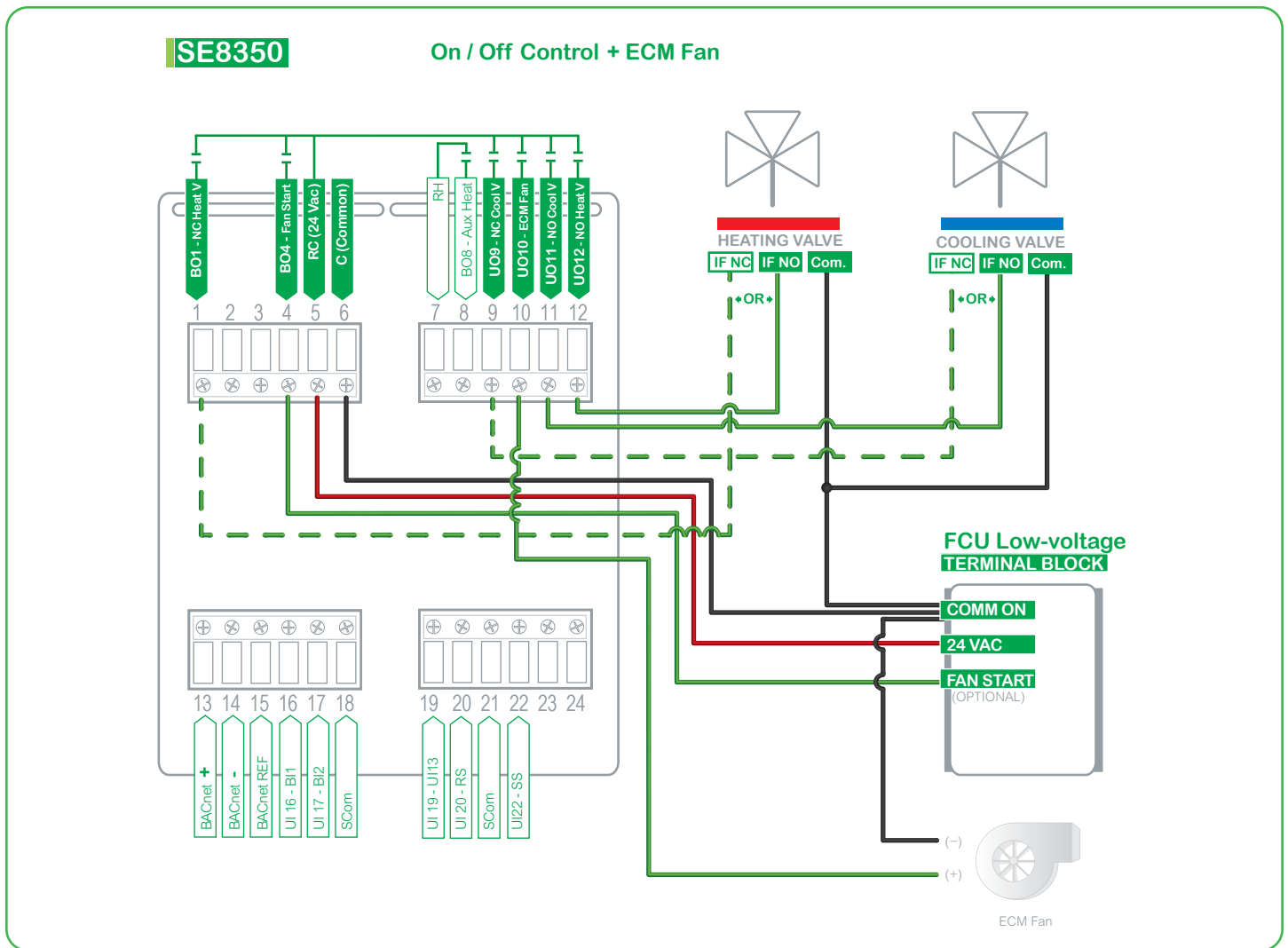

## Sequence of Operation and Wiring

### Occupied Mode

Setpoints revert to those defined by occupied cooling and heating.

### Stand-by Mode (only available when PIR motion detector sensor is used)

Setpoints revert to those defined by stand-by cooling and heating.

### Unoccupied Mode

Setpoints revert to those defined by unoccupied heating and cooling.

### Occupied Override Mode

System reverts to occupied mode for duration determined by "ToccTime" parameter.

### On Call for Cool

Cooling valve opens to maintain room temperature. Heating valve closes. Dehumidification enabled.

### On Call for Heat

Heating valve opens to maintain room temperature. Cooling valve closes. Dehumidification disabled.

### On Demand for Dehumidification

Dehumidification is achieved via cooling coil using heating coil for reheat if necessary.

Dehumidification only allowed in COOL mode, or if cooling is enabled in AUTO mode.

Dehumidification disabled if room temperature falls below low ambient lockout temperature, which is cooling setpoint minus configuration defined deadband value.

Reheat disabled if cooling demand reaches 100%.

## ECM Fan Operation

### System Off

- UO10 = 0 Vdc and BO4 (fan start) is not energized

### System On: (Fan modes)

- Low: UO10 = 2.2 Vdc (adjustable from configuration menu) and BO4 “fan start” is energized.
- Med: UO10 = 6.0 Vdc (adjustable from configuration menu) and BO4 “fan start” is energized.
- High: UO10 = 8.6 Vdc (adjustable from configuration menu) and BO4 “fan start” is energized.
- Auto: When there is no demand, UO10 = 0 Vdc and BO4 “fan start” is not energized. On demand, system will modulate from “low” to “high” voltages (adjustable from configuration menu) and BO4 “fan start” is energized.

## Options

- Wireless adapter modules are available. (see Appendix B for network wiring).
- Models available with factory installed PIR sensor.
- Remote wall mount or duct sensor ready.
- Can be configured for 2-pipe systems.
- 3 universal inputs can be used and configured for advanced functionality as required by the application.
- Universal input can be configured for changeover sensor.

## SE8350 COOLING WITH REHEAT 4-PIPE FAN COIL UNIT WITH ECM FAN, ANALOG COOLING VALVE AND N.C. ON/OFF HEATING VALVE FOR LOW VOLTAGE

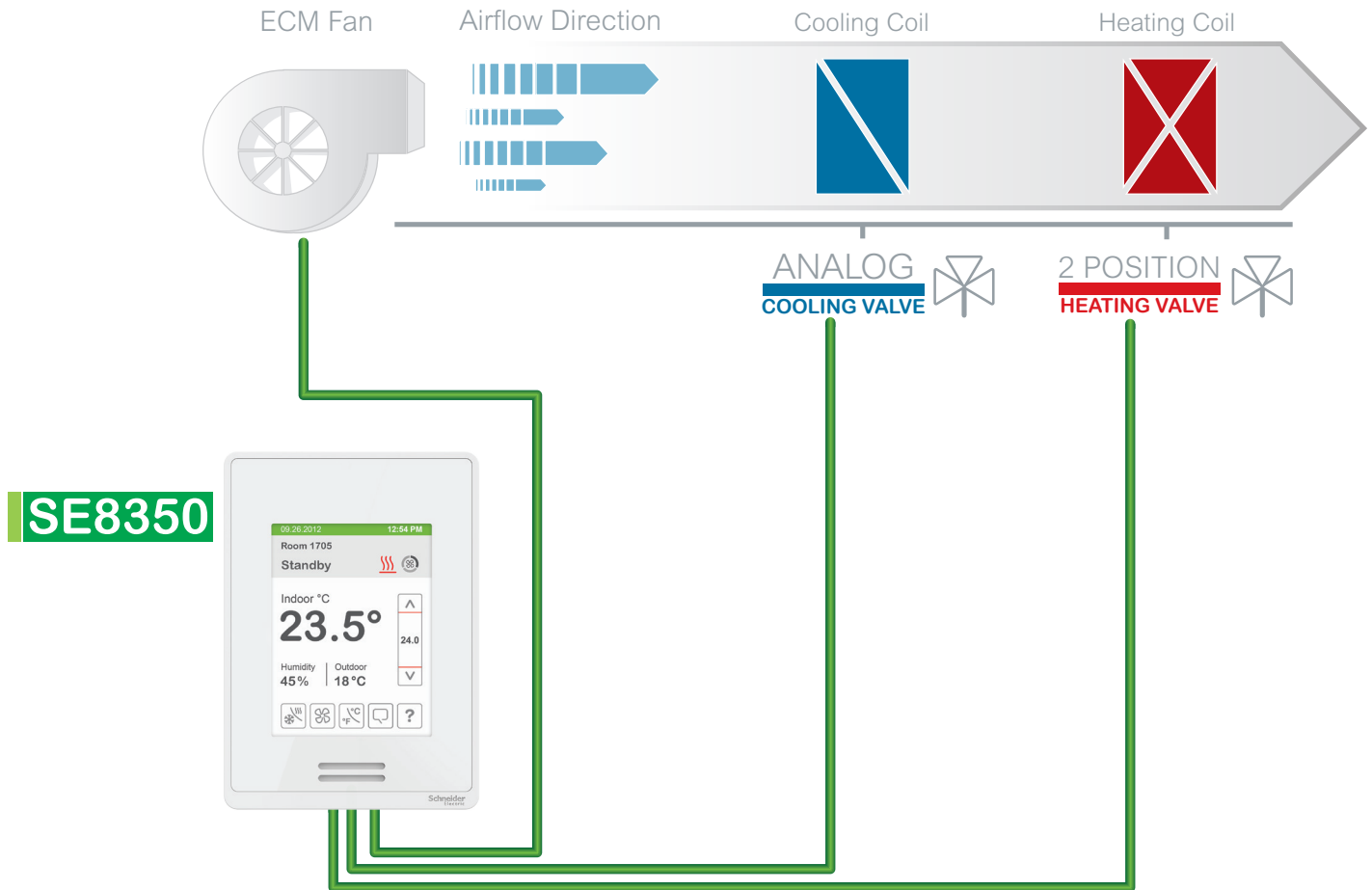

Configuration Parameter Name	Configuration Settings
Fan type	ECM
Ctrl. type out1	0-10V DA or 0-10V RA (Analog)
Ctrl. type out2	Same as 1
Fan menu	L-M-H-A
BO8 out time	15 min.
BO8 aux. config	Reheat NO
No. of pipes	2 (Configured for 2-Pipe application with reheat)
Operation sequence	Cool-rht

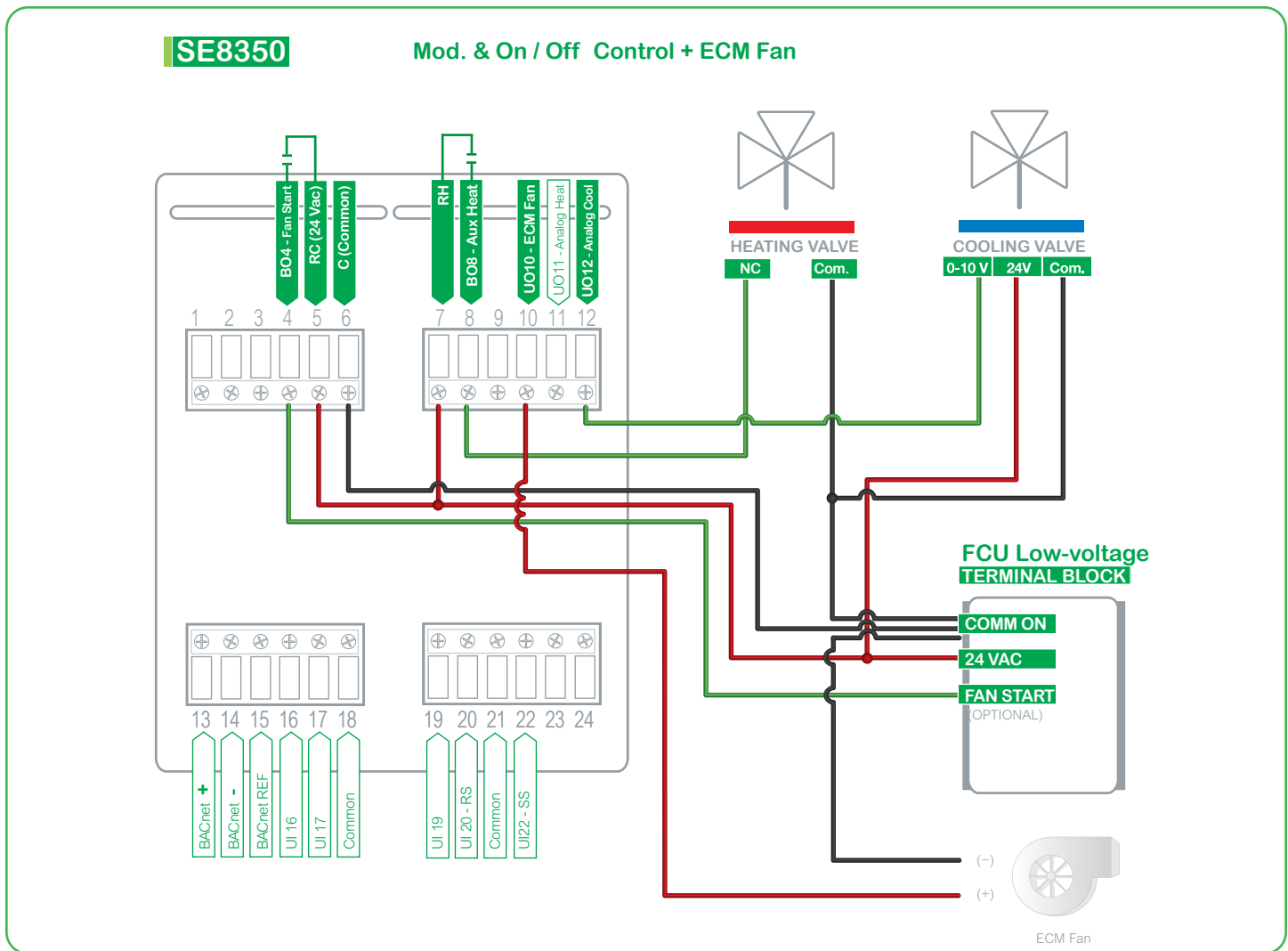

## Sequence of Operation and Wiring

### Occupied Mode

Setpoints revert to those defined by occupied cooling and heating.

### Stand-by Mode (only available when PIR motion detector sensor is used)

Setpoints revert to those defined by stand-by cooling and heating.

### Unoccupied Mode

Setpoints revert to those defined by unoccupied heating and cooling.

### Occupied Override Mode

System reverts to occupied mode for duration determined by "ToccTime" parameter.

### On Call for Cool

Analog valve starts modulating based on cooling demand.

### On Call for Heat

Heating valve opens.

## Options

- Wireless adapter modules are available. (see Appendix B for network wiring).
- Remote wall mount or duct sensor ready.
- Can be configured for 2-pipe systems.
- Can be configured to single or two speed fan.
- 3 universal inputs can be used and configured for advanced functionality as required by the application.

## ECM Fan Operation

### System Off

UO10 = 0 Vdc and BO4 (fan start) is not energized

### System On: (Fan modes)

- Low: UO10 = 2.2 Vdc (adjustable from configuration menu) and BO4 “fan start” is energized.
- Med: UO10 = 6.0 Vdc (adjustable from configuration menu) and BO4 “fan start” is energized.
- High: UO10 = 8.6 Vdc (adjustable from configuration menu) and BO4 “fan start” is energized.
- Auto: When there is no demand, UO10 = 0 Vdc and BO4 “fan start” is not energized. On demand, system will modulate from “low” to “high” voltages (adjustable from configuration menu) and BO4 “fan start” is energized.

**SpaceLogic SER8350/SE8350 [ Application Guide ]**

**SE8350 COOLING ONLY 2-PIPE FAN COIL UNIT WITH ECM FAN AND 0-10 VDC ANALOG COOLING VALVE FOR LOW VOLTAGE**

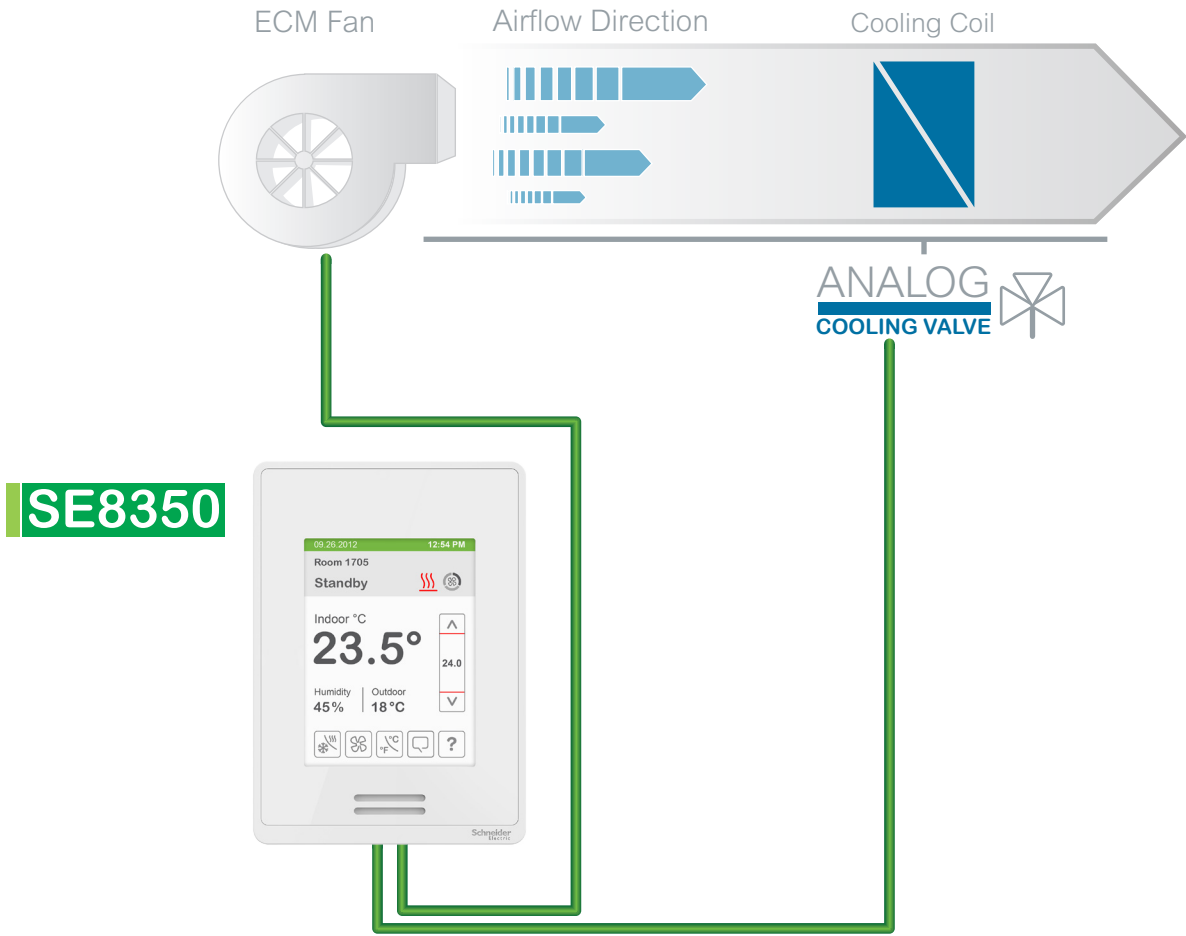

Configuration Parameter Name	Configuration Settings
Fan type	ECM
Ctrl. type out1	0-10V DA or 0-10V RA (Analog)
Ctrl. type out2	Same as 1
Fan menu	L-M-H-A
No. of pipes	2
Operation sequence	Cool only

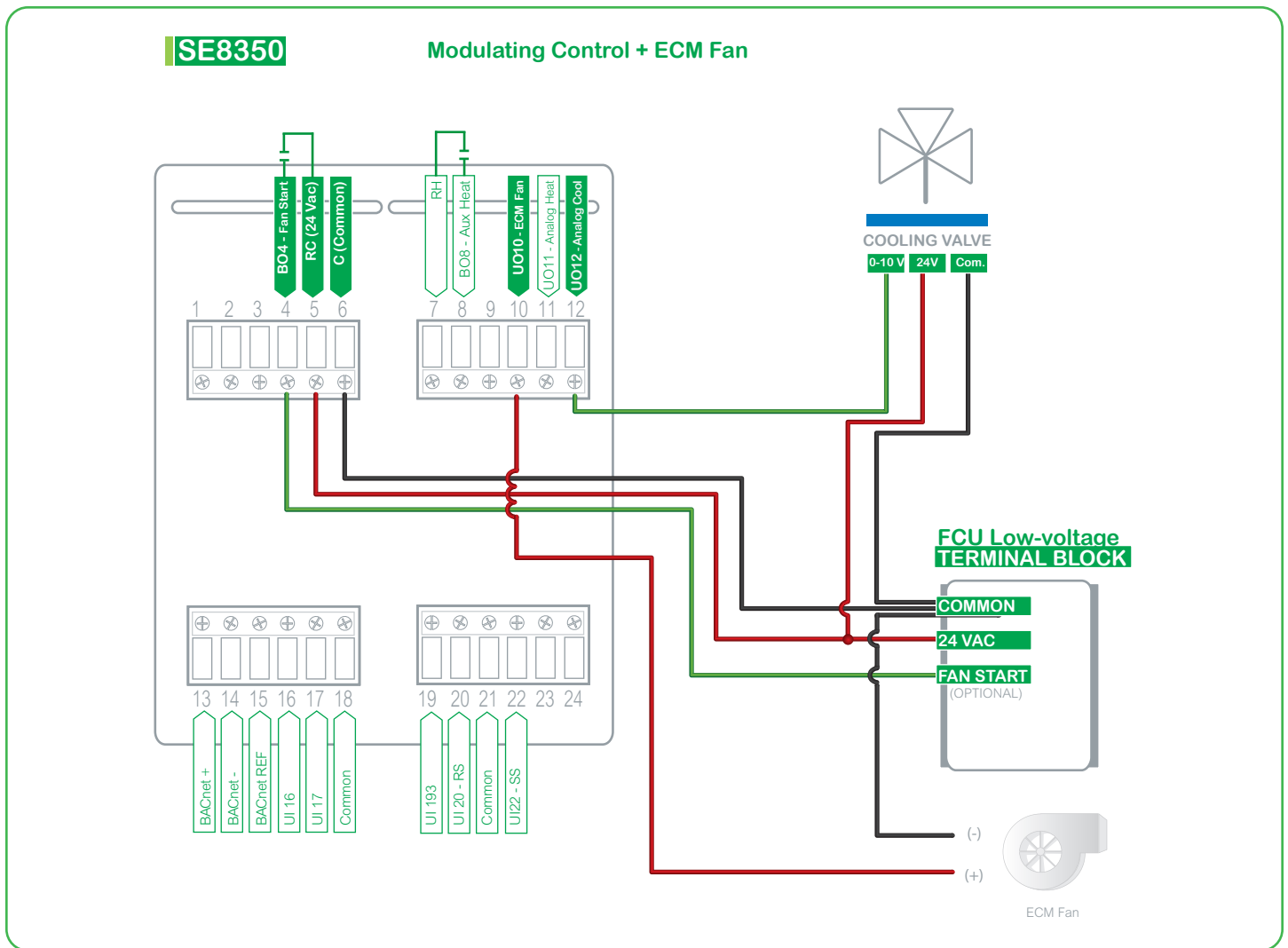

## Sequence of Operation and Wiring

### Occupied Mode

Setpoints revert to those defined by occupied cooling and heating.

### Stand-by Mode (only available when PIR motion detector sensor is used)

Setpoints revert to those defined by stand-by cooling and heating.

### Unoccupied Mode

Setpoints revert to those defined by unoccupied heating and cooling.

### Occupied Override Mode

System reverts to occupied mode for duration determined by "ToccTime" parameter.

### On Call for Cool

Analog valve modulates allowing cool air to flow to reach setpoint.

### On Call for Heat

Valve closes.

## Options

- Wireless adapter modules are available. (see Appendix B for network wiring).
- Remote wall mount or duct sensor ready.
- Can be configured for 4-pipe systems.
- 3 universal inputs can be used and configured for advanced functionality as required by the application.
- Can be configured to two or three speed fan.

## ECM Fan Operation

### System Off

UO10 = 0 Vdc and BO4 (fan start) is not energized

### System On: (Fan modes)

- Low: UO10 = 2.2 Vdc (adjustable from configuration menu) and BO4 “fan start” is energized.
- Med: UO10 = 6.0 Vdc (adjustable from configuration menu) and BO4 “fan start” is energized.
- High: UO10 = 8.6 Vdc (adjustable from configuration menu) and BO4 “fan start” is energized.
- Auto: When there is no demand, UO10 = 0 Vdc and BO4 “fan start” is not energized. On demand, system will modulate from “low” to “high” voltages (adjustable from configuration menu) and BO4 “fan start” is energized.

## SE8350 COOLING WITH REHEAT 2-PIPE FAN COIL UNIT WITH ECM FAN, 2-POSITION VALVE AND ELECTRIC REHEAT FOR LOW VOLTAGE



Configuration Parameter Name	Configuration Settings
Fan type	ECM
Fan menu	L-M-H-A
Ctrl. type out1	On/Off
Ctrl. type out2	Same as 1
BO8 out time	15 min.
BO8 aux. config	Reheat NO
No. of pipes	2
Operation sequence	Cool-rht

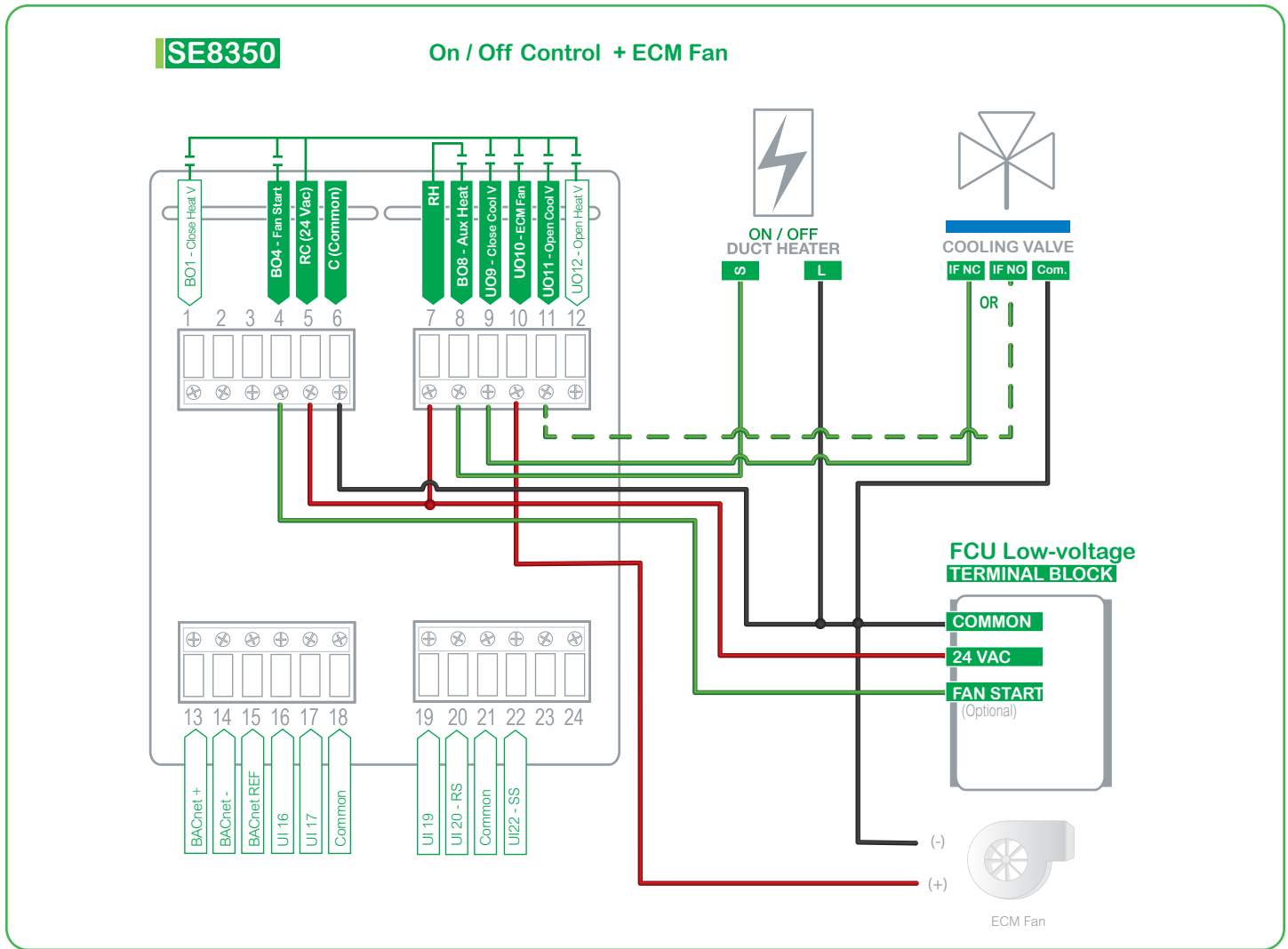

**Sequence of Operation and Wiring**

**Occupied Mode**

Setpoints revert to those defined by occupied cooling and heating.

**Stand-by Mode (only available when PIR motion detector sensor is used)**

Setpoints revert to those defined by stand-by cooling and heating.

**Unoccupied Mode**

Setpoints revert to those defined by unoccupied heating and cooling.

**Occupied Override Mode**

System reverts to occupied mode for duration determined by "ToccTime" parameter.

**On Call for Cool**

Cooling valve opens. Electric heat stays Off.

**On Call for Heat**

Valve closes. Electric heat activates.

## Options

- Wireless adapter modules for BACnet models are available. (see Appendix B for network wiring).
- Remote wall mount or duct sensor ready.
- Can be configured for 4-pipe systems.
- 3 universal inputs can be used and configured for advanced functionality as required by the application.

Can be configured to single or two speed fan.

## ECM Fan Operation

### System Off

UO10 = 0 Vdc and BO4 (fan start) is not energized

### System On: (Fan modes)

- Low: UO10 = 2.2 Vdc (adjustable from configuration menu) and BO4 “fan start” is energized.
- Med: UO10 = 6.0 Vdc (adjustable from configuration menu) and BO4 “fan start” is energized.
- High: UO10 = 8.6 Vdc (adjustable from configuration menu) and BO4 “fan start” is energized.
- Auto: When there is no demand, UO10 = 0 Vdc and BO4 “fan start” is not energized. On demand, system will modulate from “low” to “high” voltages (adjustable from configuration menu) and BO4 “fan start” is energized.

**SpaceLogic**  
**SE8350**  
**Mixed Voltage**

**SE8350****3-SPEED MIXED VOLTAGE APPLICATIONS**

System	Fan	Cooling	Heating	Other
4 pipes	3-speed 230 Vac	0-10 Vdc valve actuator	0-10 Vdc valve actuator	need the optional VC2300 relay box
4 pipes	3-speed 230 Vac	Tri-state valve actuator	Tri-state valve actuator	need the optional VC2300 relay box

**SpaceLogic SER8350/SE8350 [ Application Guide ]**

**MIXED VOLTAGE SE8350 AND VC2300 230 VAC RELAY HEATING/COOLING 4-PIPE FAN COIL UNIT WITH HIGH VOLTAGE 3-SPEED FAN, AND 0-10 VDC ANALOG VALVES AND DEHUMIDIFICATION SEQUENCE FOR LOW VOLTAGE**

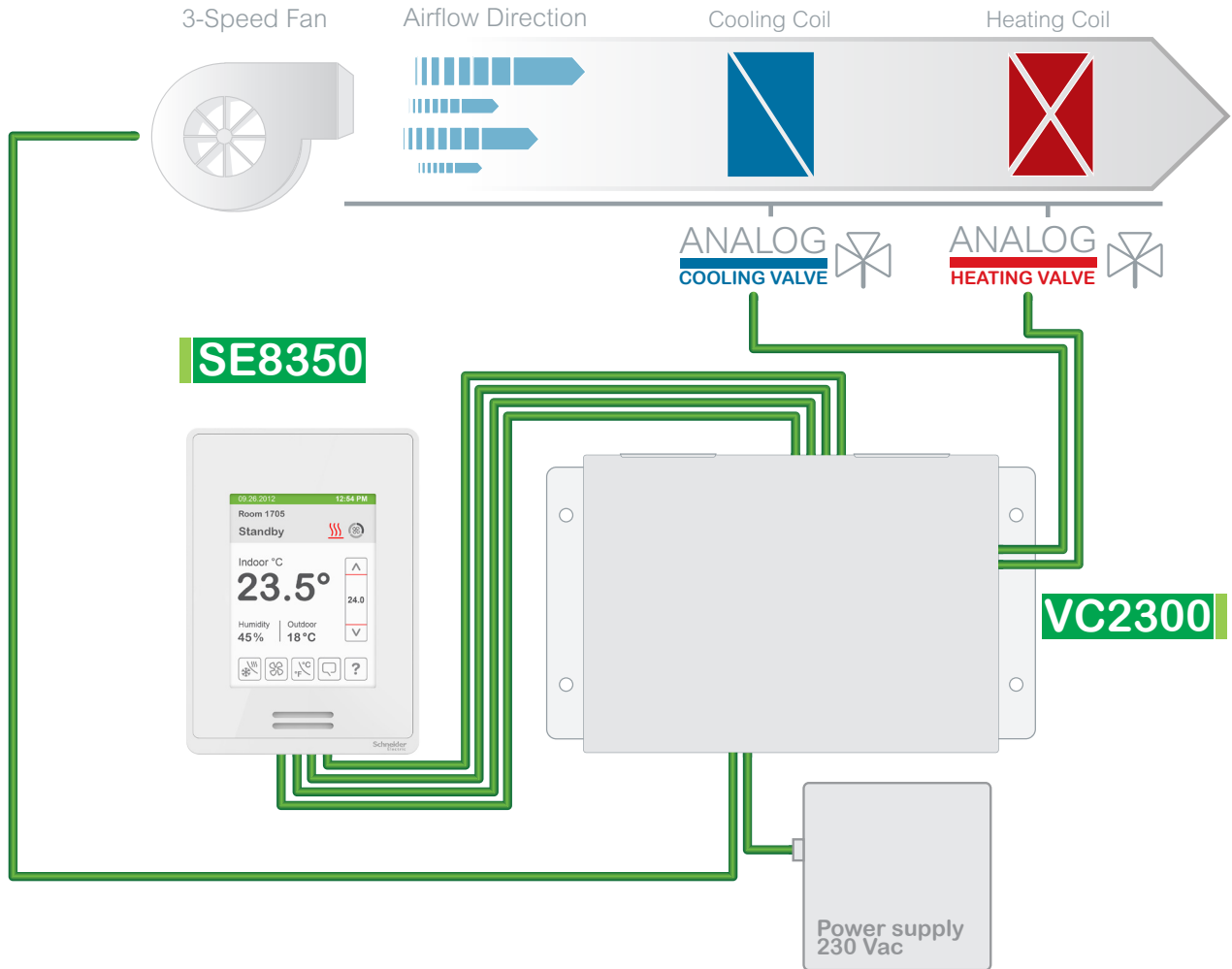

Configuration Parameter Name	Configuration Settings
Fan type	3 speed
Fan menu	L-M-H-A
Ctrl. type out1	0-10V DA or 0-10V RA (Analog)
Ctrl. type out2	Same as 1
No. of pipes	4
Operation sequence	Cool/Heat

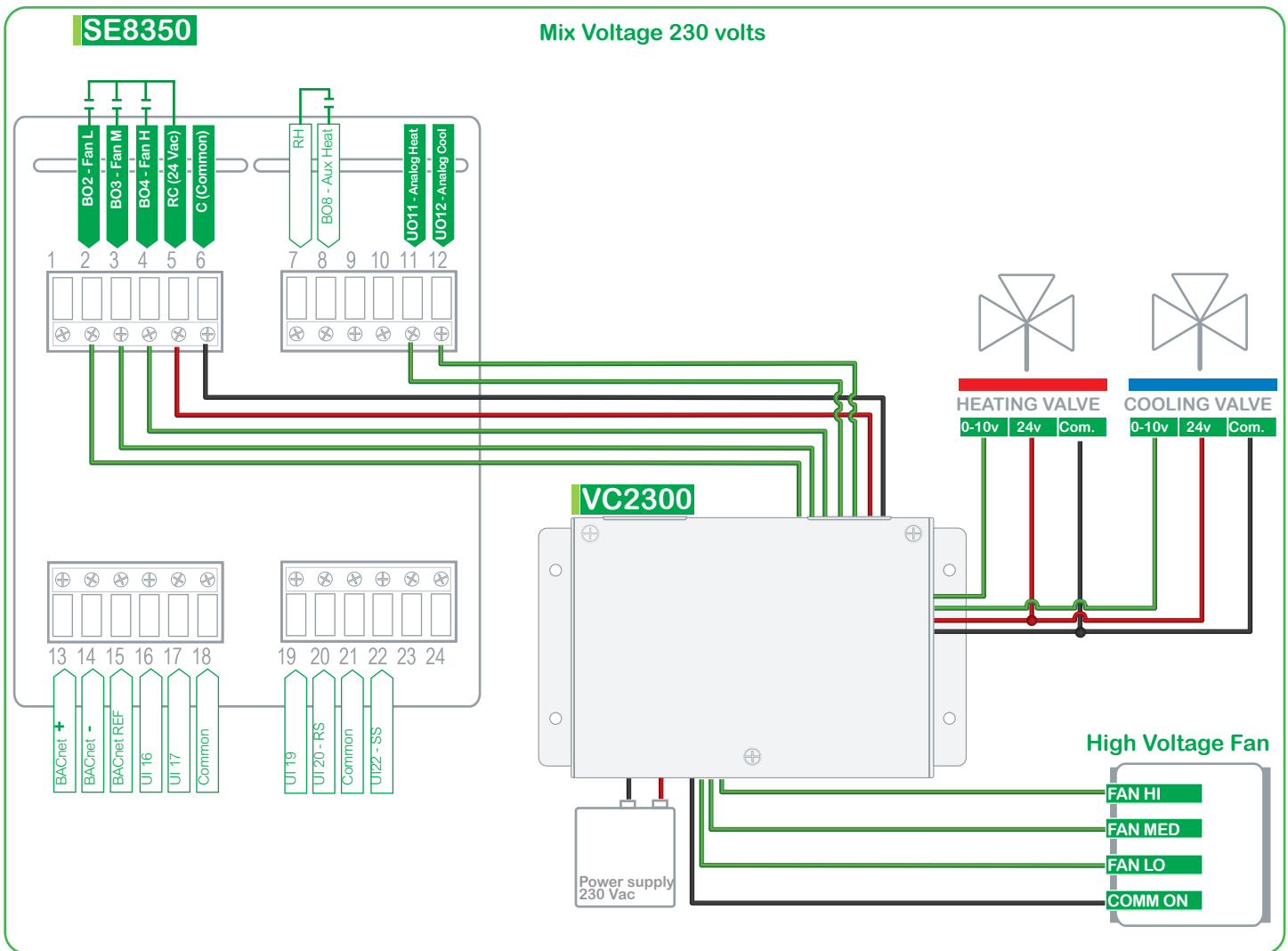

## Sequence of Operation and Wiring

### Occupied Mode

Setpoints revert to those defined by occupied cooling and heating. The changeover sensor sends supply air temperature to controller.

### Stand-by Mode (only available when PIR motion detector sensor is used)

Setpoints revert to those defined by stand-by cooling and heating.

### Unoccupied Mode

Setpoints revert to those defined by unoccupied heating and cooling.

### Occupied Override Mode

System reverts to occupied mode for duration determined by "ToccTime" parameter.

### On Call for Cool

Cooling valve opens to maintain room temperature. Heating valve closes. Dehumidification enabled.

### On Call for Heat

Heating valve opens to maintain room temperature. Cooling valve closes. Dehumidification disabled.

### On Demand for Dehumidification

Dehumidification is achieved via cooling coil using heating coil for reheat if necessary.

Dehumidification only allowed in COOL mode, or if cooling is enabled in AUTO mode.

Dehumidification disabled if room temperature falls below low ambient lockout temperature, which is cooling setpoint minus configuration defined deadband value.

Reheat disabled if cooling demand reaches 100%.

### Options

- Wireless adapter modules are available. (see Appendix B for network wiring).
- Remote wall mount or duct sensor ready.
- Can be configured for 2-pipe systems.
- 3 universal inputs can be used and configured for advanced functionality as required by the application.
- Universal input can be configured for changeover sensor.

**SpaceLogic SER8350/SE8350 [ Application Guide ]**

**MIXED VOLTAGE SE8350 AND VC2300 230 VAC RELAY HEATING/COOLING 4-PIPE FAN COIL UNIT WITH HIGH VOLTAGE 3-SPEED FAN, TRI-STATE FLOATING VALVES AND DEHUMIDIFICATION SEQUENCE FOR LOW VOLTAGE**

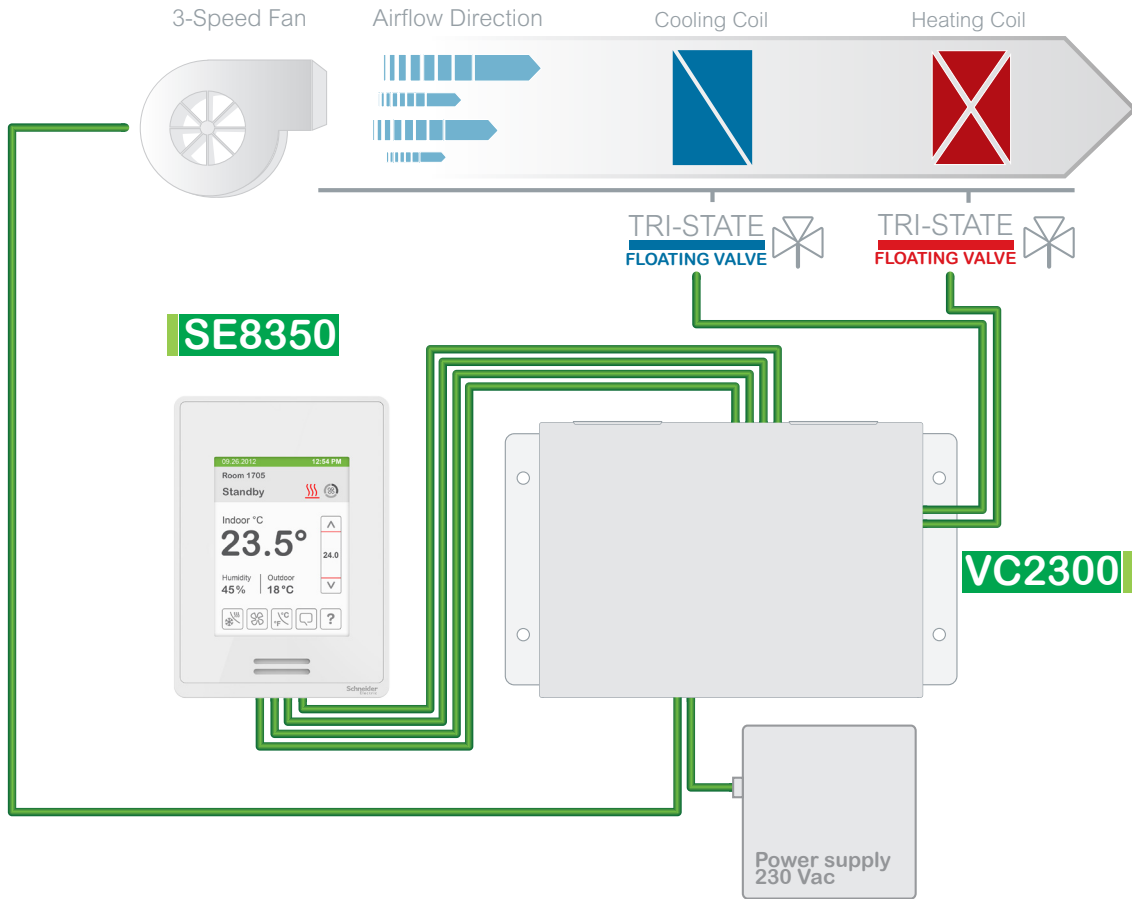

Configuration Parameter Name	Configuration Settings
Fan type	3 speed
Fan menu	L-M-H-A
Ctrl. type out1	Floating
Ctrl. type out2	Same as 1
No. of pipes	4
Operation sequence	Cool/Heat

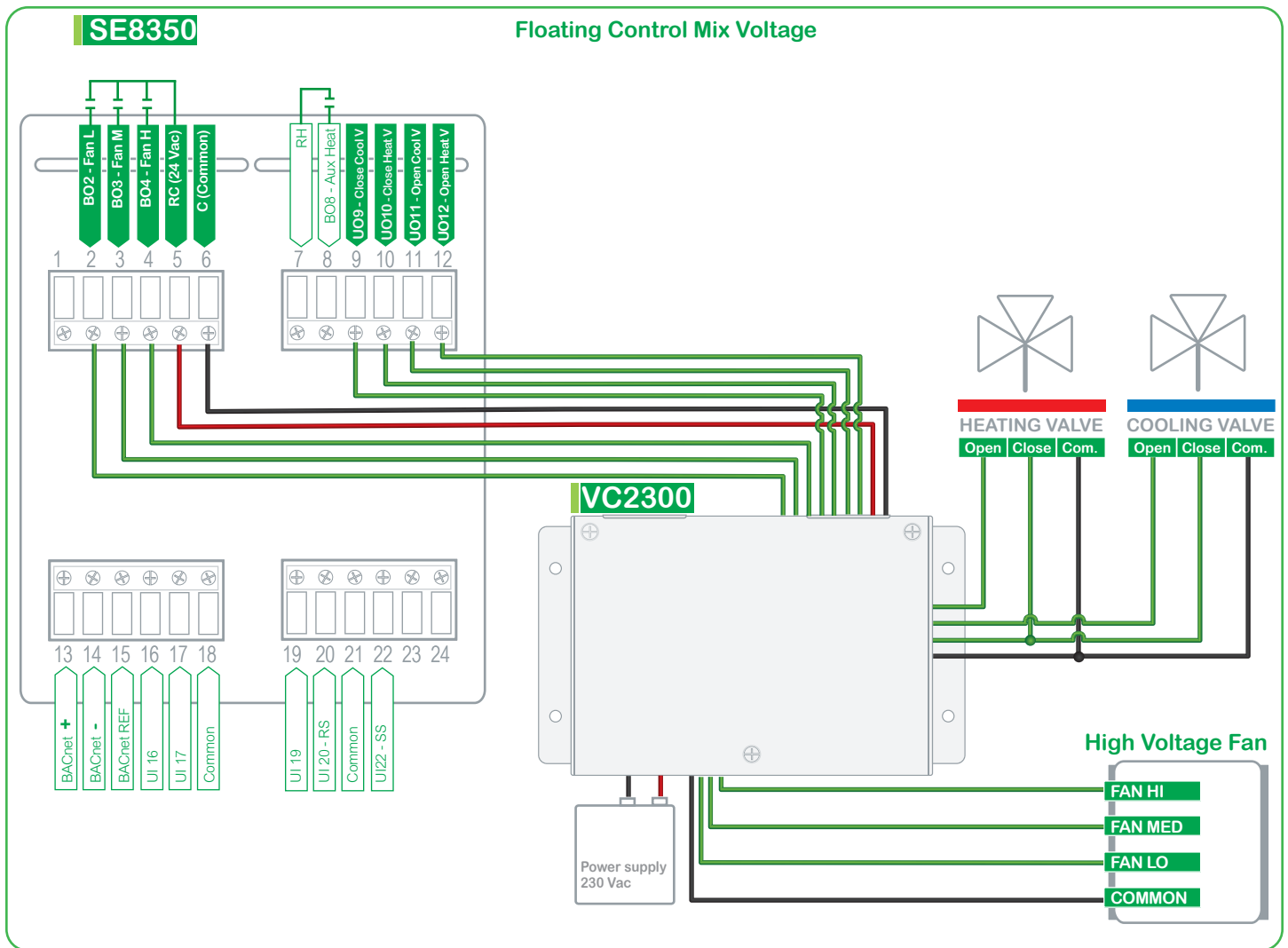

## Sequence of Operation and Wiring

### Occupied Mode

Setpoints revert to those defined by occupied cooling and heating.

### Stand-by Mode (only available when PIR motion detector sensor is used)

Setpoints revert to those defined by stand-by cooling and heating.

### Unoccupied Mode

Setpoints revert to those defined by unoccupied heating and cooling.

### Occupied Override Mode

System reverts to occupied mode for duration determined by "ToccTime" parameter.

### On Call for Cool

Cooling valve opens to maintain room temperature. Heating valve closes.

### On Call for Heat

Heating valve opens to maintain room temperature. Cooling valve closes.

### On Demand for Dehumidification

Dehumidification is achieved via cooling coil using heating coil for reheat if necessary.

Dehumidification is only allowed in COOL mode, or if cooling is enabled in AUTO mode.

Dehumidification is disabled if room temperature falls below low ambient lockout temperature, which is the cooling setpoint minus the configuration defined deadband value.

Reheat disabled if cooling demand reaches 100%.

## Options

- Wireless adapter modules are available. (see Appendix B for network wiring).
- Remote wall mount or duct sensor ready.
- Can be configured for 2-pipe systems with changeover.
- 3 universal inputs can be used and configured for advanced functionality as required by the application.
- Universal input can be configured for changeover sensor.

APPENDIX A - VC3000 RELAY PACK WIRING

TYPICAL WIRING EXAMPLES FOR 3 SPEED FAN

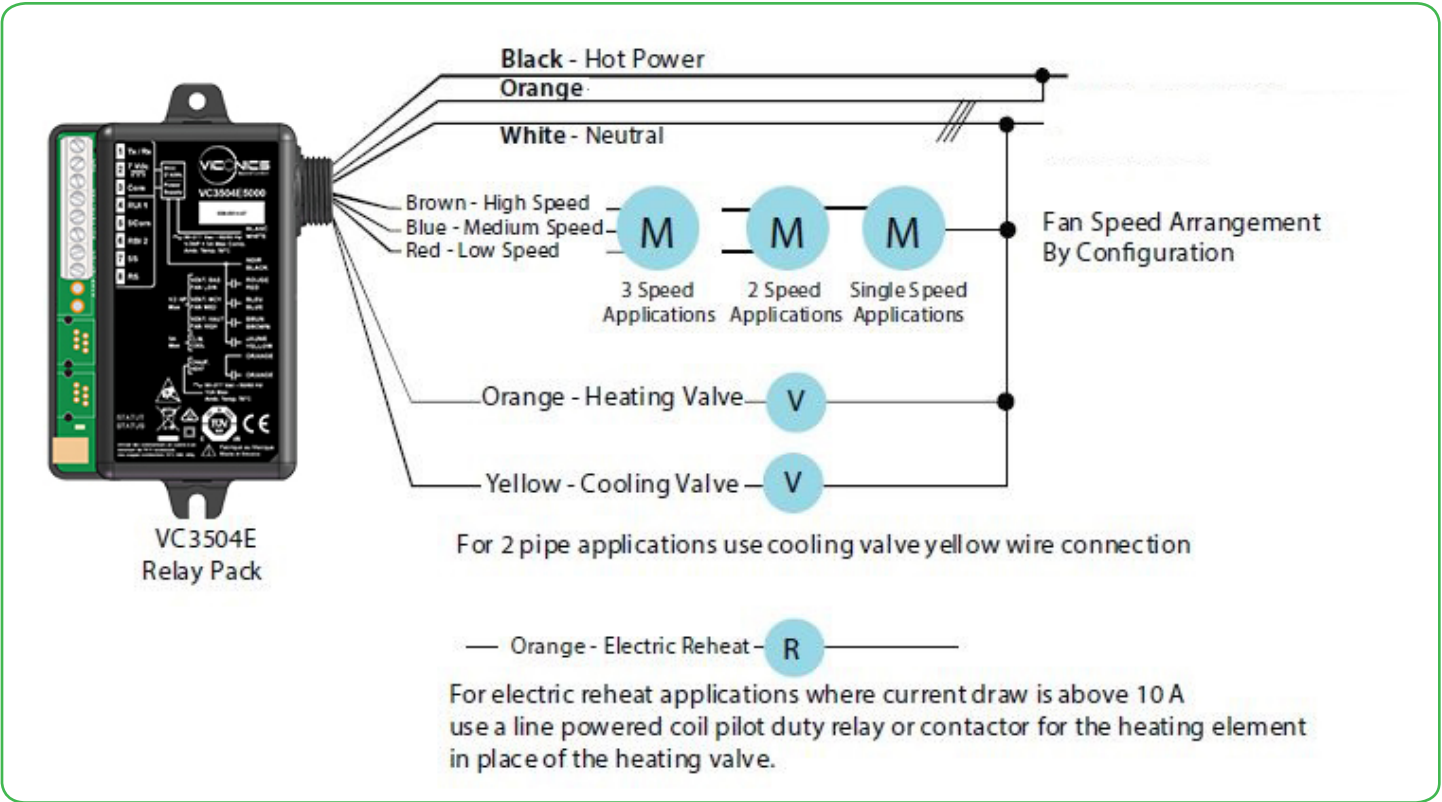

TYPICAL WIRING EXAMPLES FOR ECM FAN

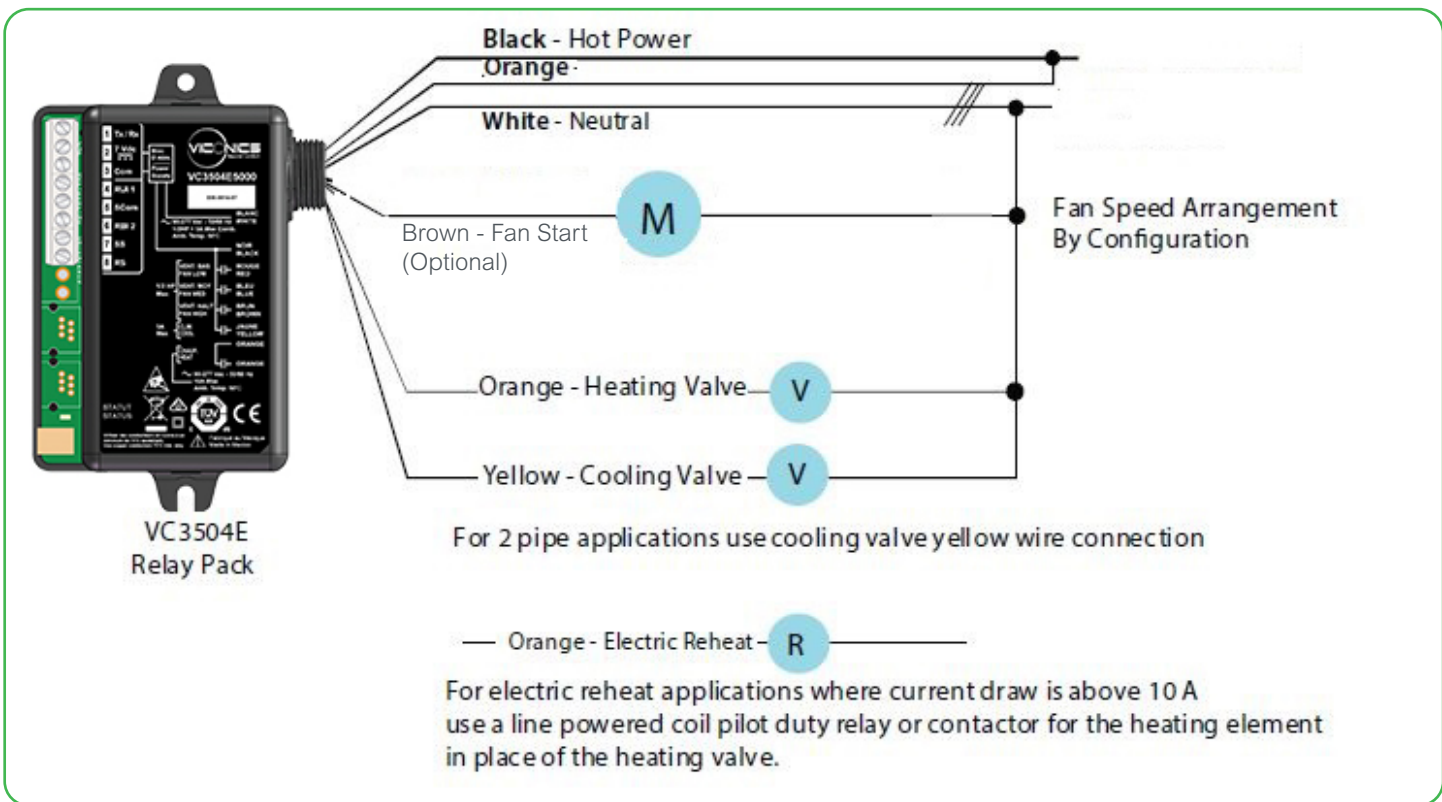

## APPENDIX B - OPTIONAL NETWORK SET-UP

### BACnet communication wiring

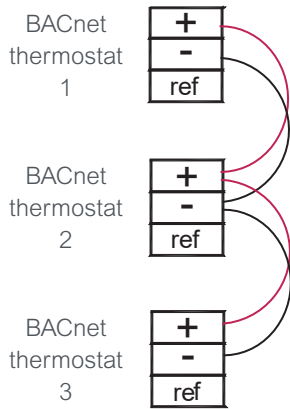

**Notes:**

- Wiring should be daisy chained
- Respect polarity
- If using 2 conductor shielded wires, connect the shield of each feed together on the back of the controller. ONLY ground the shield at one location. DO NOT connect the shield to the ref terminal.

## APPENDIX C - WIRELESS SENSORS

### Wireless ZigBee® Pro Motion Sensors

Room Controllers with SED Series ZigBee® Pro wireless switches can be used in stand-alone mode, or with integration to a central management system, to allow for advanced functions such as central reservation and occupancy functions. Up to twenty different ZigBee motion sensors and switches (SED-WDC, SED-MTH, or SED-WLS) can be used with a Room Controller.

Note that if a ZigBee wireless window switch is used, the Room Controller cannot also use a remote PIR motion sensor, whether wired or wireless. Using one or more wireless remote PIR motion sensors means that a wired PIR motion sensor cannot be used, and vice versa.

The SED Series sensors are factory delivered with batteries and are ready to be installed, configured, and used right out of the box. Due to the extremely small current consumption of the sensors, the expected battery life is approximately 10 years, which is equivalent to the battery shelf life.

### Model Selection

Description	Part Number
Wireless window/door sensor	SED-WDC-G-5045
Wireless motion/temperature/humidity sensor	SED-MTH-G-5045
Wireless water leakage sensor	SED-WLS-G-5045

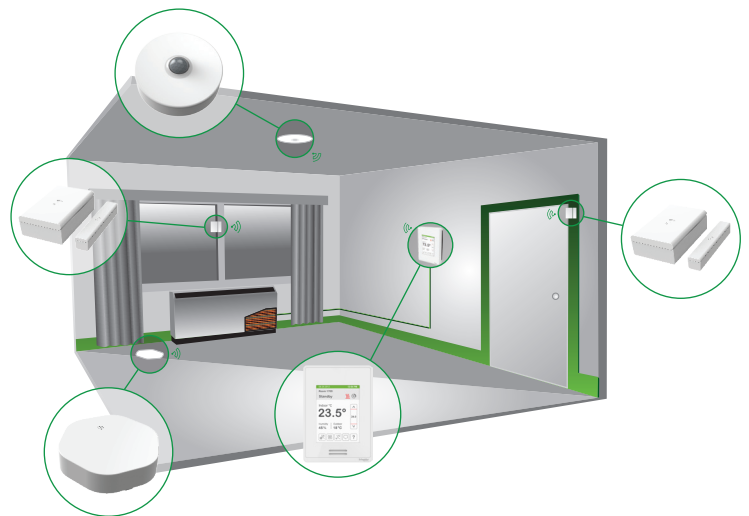

APPENDIX D - SCHEMATIC OF CONTROLLERS OCCUPANCY SEQUENCE OF OPERATION WITHOUT DOOR SENSOR

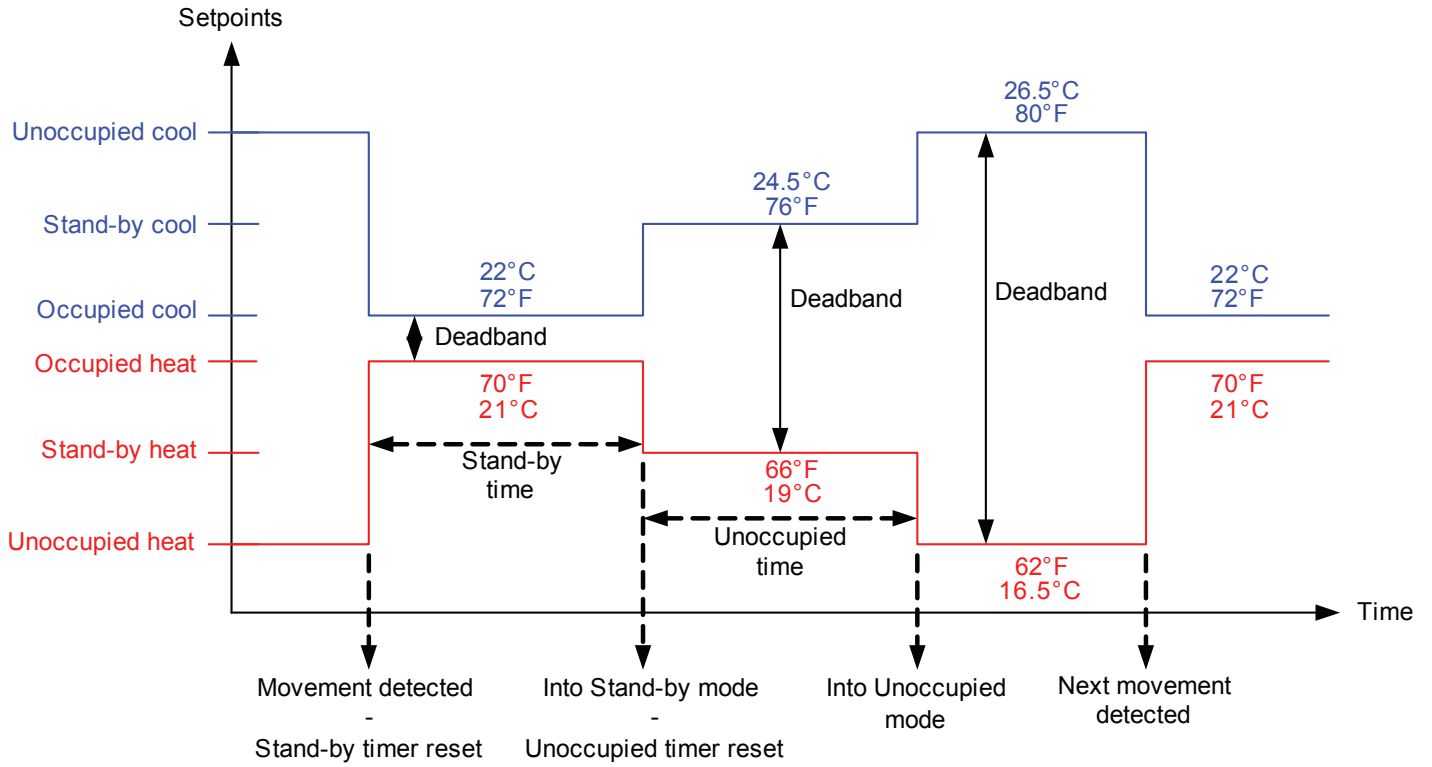

## APPENDIX E - DEPLOYMENT

Placement of the Room Controller must be given consideration. It is recommended to install the Room Controller as close to a door as possible (but not so as to be blocked by the door), or in an area with high occupant movement.

Ideally the Room Controller should be installed 5 feet (1.5 meters) above the floor surface to ensure maximum detection range is achieved. As well, Room Controller placement should ensure the occupant crosses the lens beam in a perpendicular path within the prescribed detection zone.

The Room Controller's PIR sensor is very sensitive and can be triggered by vibration from nearby equipment, such as fans or compressor motors. To avoid false motion detection, make sure to place the Room Controller away from vibration sources and install vibration isolators on HVAC equipment.

### Example of Recommended Deployment

The below shows Room Controllers installed in ideal locations for two rooms.

The examination room shows one Room Controller installed adjacent to the door. In this area of the room, occupant traffic is high and ensures the occupant will almost always cross the PIR detection path laterally and within the detection range.

The waiting room shows one Room Controller installed beside a door in the middle of the room. As shown in the diagram below, occupant traffic is high in several areas of the room including the entrance, waiting room, access to the door and activity around the reception desk. Moreover, for each case aforementioned, occupant movement almost always moves lateral to the PIR, which ensures detection by the PIR, as well as respecting the PIR detection range of 20 feet (6 meters) at 140°, and 16 feet (5 meters) between 15° to 30° laterally.

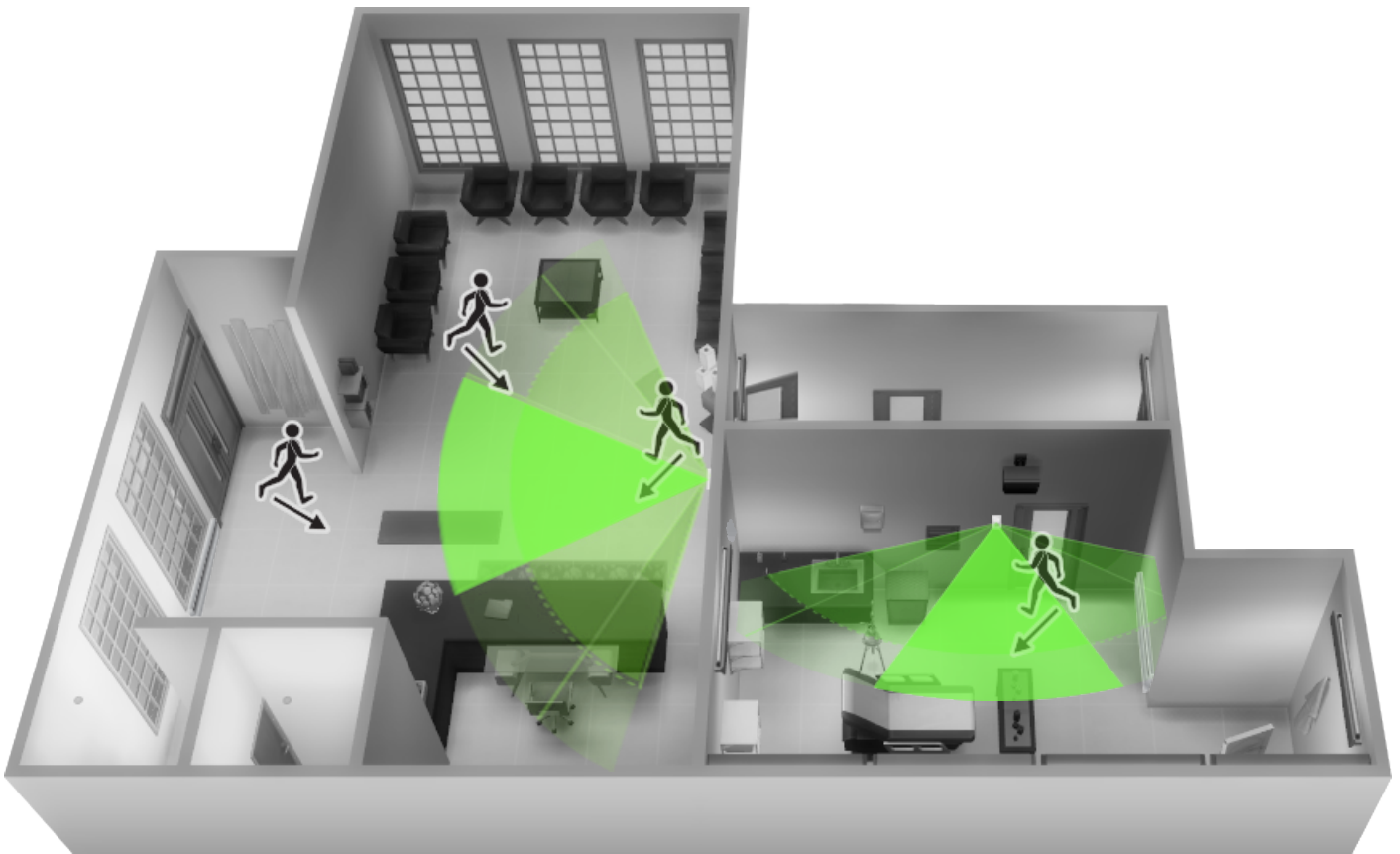

Recommended Installation

### Example of Non-Recommended Deployment

The below shows four Room Controllers (two for each room) installed in non-ideal locations for the two rooms.

The examination room shows one Room Controller installed in a low traffic area near the door, and a second Room Controller installed on the wall directly opposite the door. For the Room Controller installed in the corner wall, the PIR could be blocked by the opened door, while occupant traffic could also be minimal in this area of the room. For the second Room Controller installed opposite the door, the PIR detection could fall outside the specified detection zone, while at the same time most occupant movement would be not be lateral to the PIR, thereby not respecting optimal crossing patterns for PIR detection.

The waiting room shows one Room Controller installed in the corner of the room, and a second Room Controller installed beside the reception area. For the Room Controller installed in the corner, the opening/closing of the door creates high probability that the PIR would get blocked, and therefore, occupancy going undetected. For the Room Controller installed beside the reception area, occupant traffic could fall outside the detection zone, and the receptionist would often be below the 5 foot recommended installation height for the Room Controller.

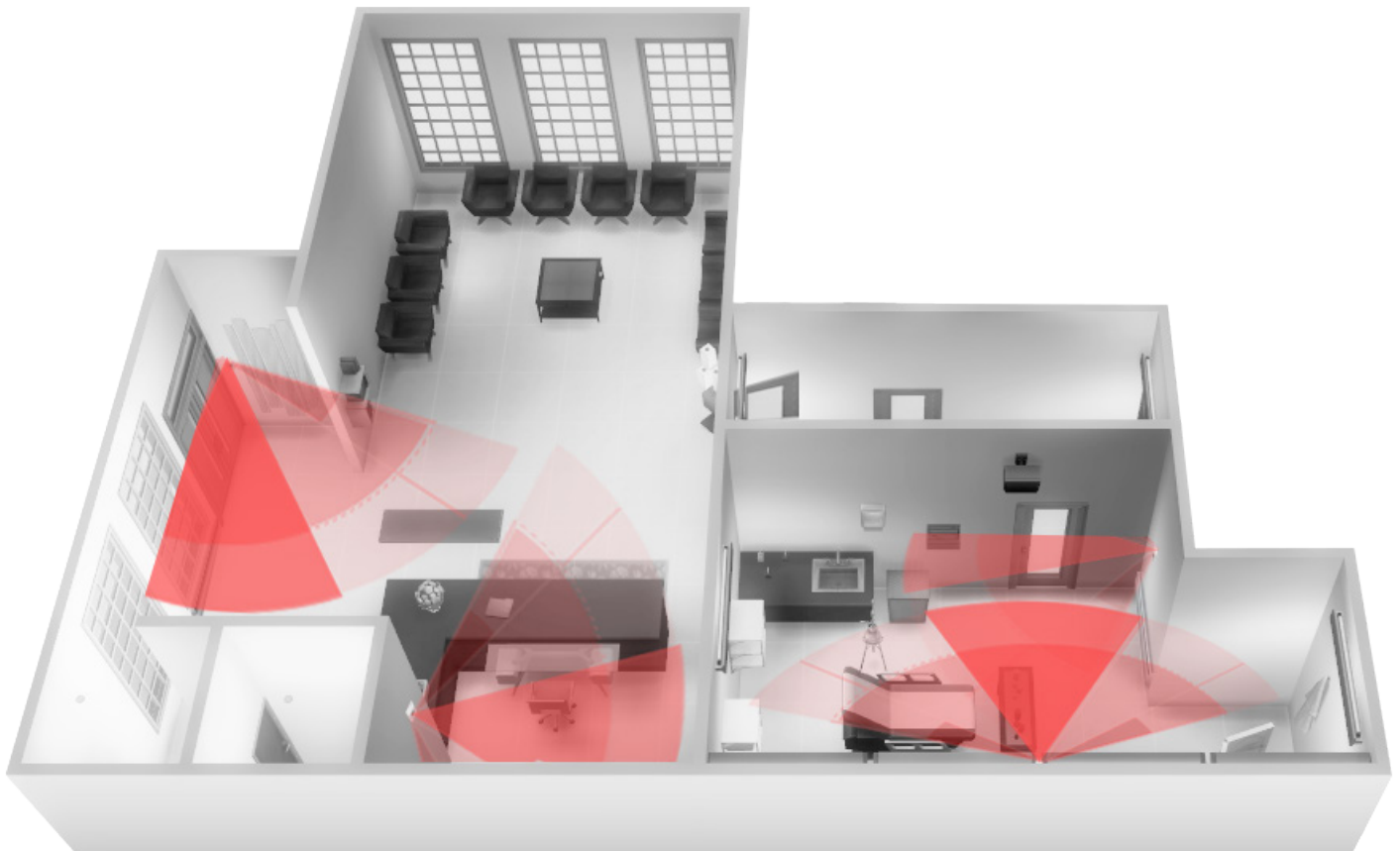

Non-Recommended Installation

### Room Controller PIR Sensor Details

The internal Room Controller PIR sensor only detect lateral movement. It cannot detect movement when a person is moving toward it. It will not detect someone seating on a chair and/or lying on the bed.

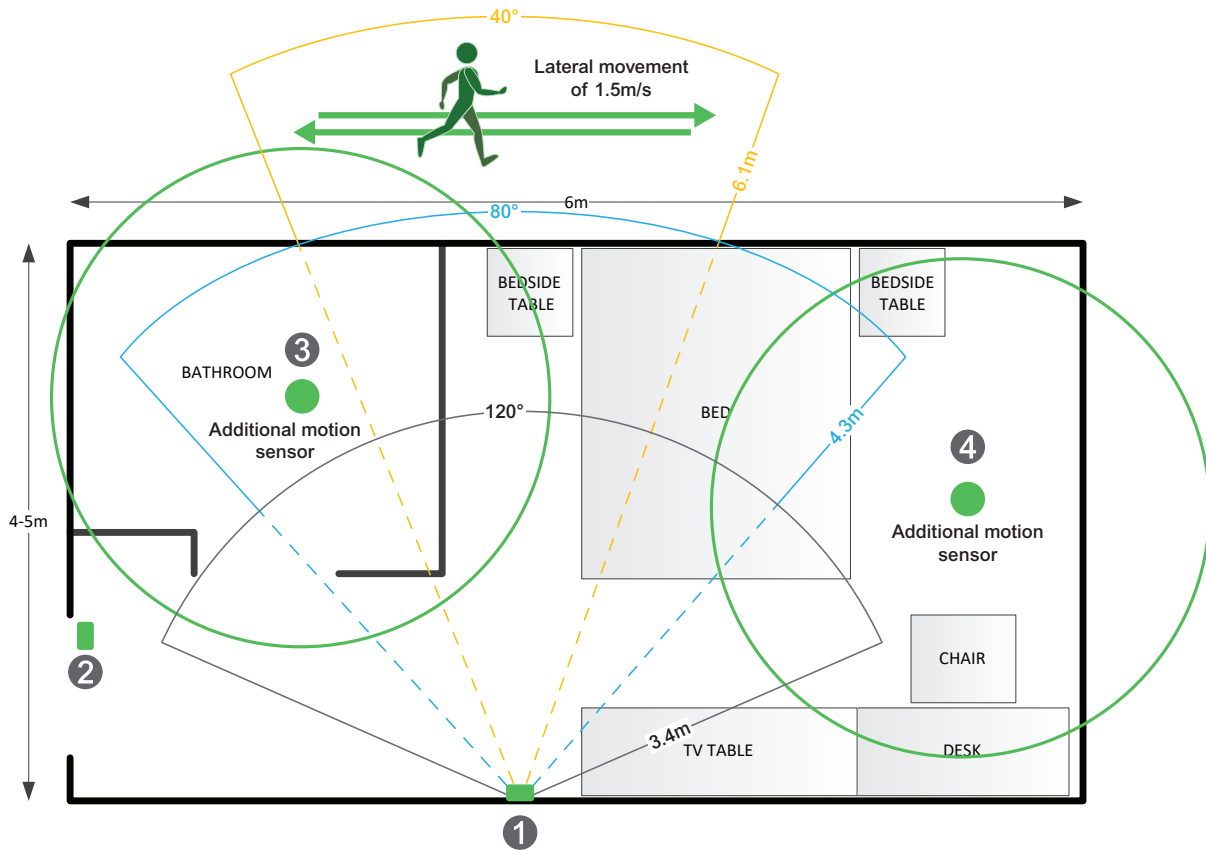

### Recommendations for Installations

1. Install the Room Controller to cover more lateral movement.
2. Install a door sensor, the internal Room Controller occupancy logic works better with a door sensor. Once a motion is detected after a door is opened, the room stays in occupied state until the door is opened again which put the Room Controller in stand-by mode and if there is a motion then it goes back in occupied mode. It is also recommended to disable the unoccupied mode, set the unoccupied time to 0, so there is only 2 modes in the Room Controller: stand-by and occupied for a stand-alone solution. Please refer to the two(2) diagrams below for the Room Controller internal occupancy states transition.

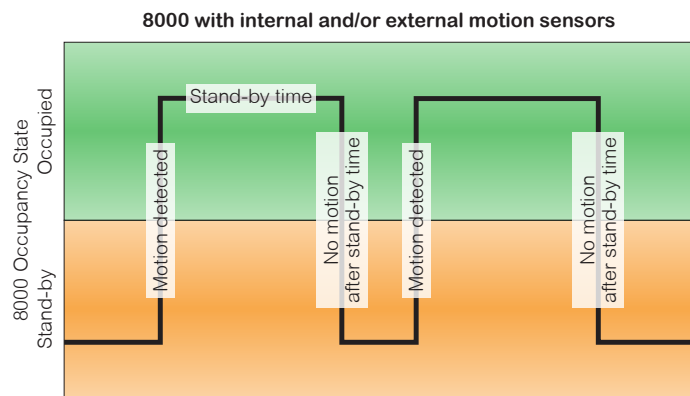

More aggressive energy savings logic but may cause bad guest experience (when guest is sleeping or not moving)

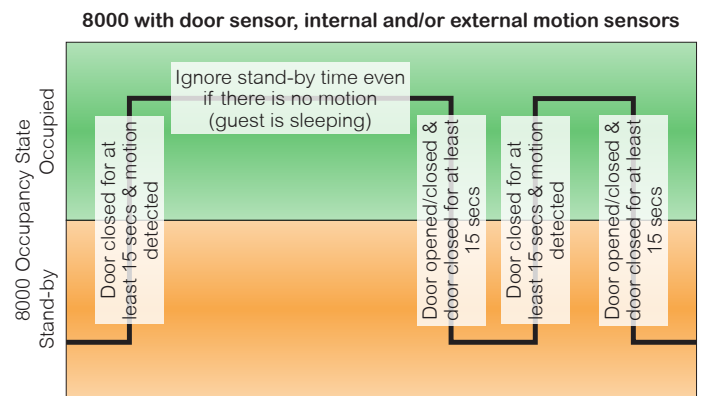

Good energy savings logic and better guest experience even when the guest is sleeping or not moving

## SpaceLogic SER8350/SE8350 [ Application Guide ]

- 3. Install additional motion sensor in the bathroom.
- 4. Install additional motion sensor for better motion detection in the entire room.

### Energy Savings

PIR can maximize your energy saving from 10-30% by adjusting temperature set points in unoccupied zones during scheduled periods.

PIR can maximize your energy saving from 10-30% by adjusting temperature set points in unoccupied zones during scheduled periods.

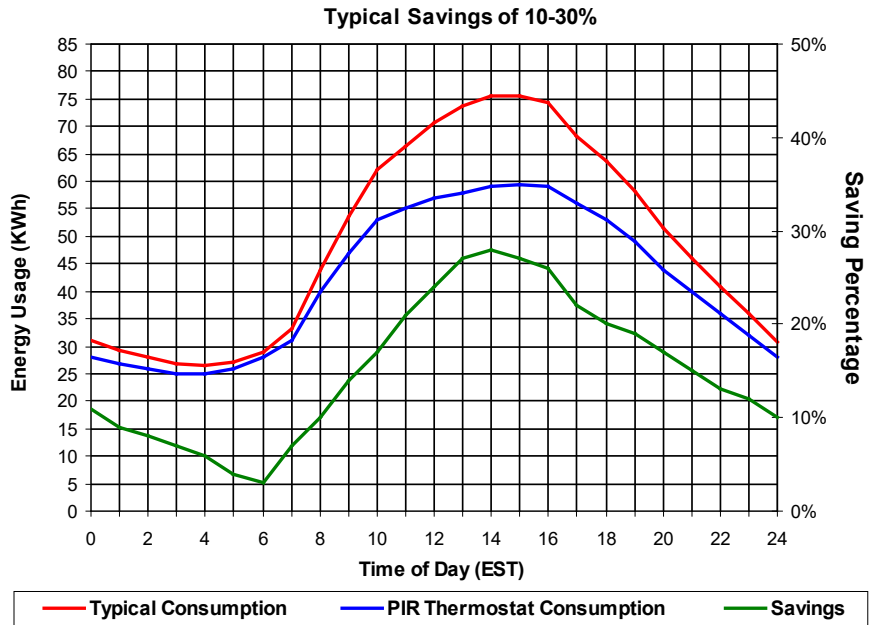

# Technical Support



For any issues with SmartStruxure Solution or SmartStruxure Lite, contact Schneider Electric Technical Support according to your region.

**North America (NAM) Product Support**  
Building Management Systems (BMS): [www.nampss.com](http://www.nampss.com)

**Global Product Support**  
Building Management Systems (BMS): [productsupport.BMS@schneider-electric.com](mailto:productsupport.BMS@schneider-electric.com)

**Schneider Electric**  
CS 30323  
F-92506 Rueil-Malmaison Cedex  
France

Schneider Electric is leading the Digital Transformation of Energy Management and Automation in Homes, Buildings, Data Centers, Infrastructure and Industries.

With global presence in over 100 countries, Schneider is the undisputable leader in Power Management – Medium Voltage, Low Voltage and Secure Power, and in Automation Systems. We provide integrated efficiency solutions, combining energy, automation and software.

In our global Ecosystem, we collaborate with the largest Partner, Integrator and Developer Community on our Open Platform to deliver real-time control and operational efficiency.

We believe that great people and partners make Schneider a great company and that our commitment to Innovation, Diversity and Sustainability ensures that Life Is On everywhere, for everyone and at every moment.

[www.schneider-electric.com](http://www.schneider-electric.com)