

# PowerLogic™

## AccuSine PCSn Active Harmonic Filter

### Installation Manual

PHA57270-04  
12/2024



# Legal Information

The information provided in this document contains general descriptions, technical characteristics and/or recommendations related to products/solutions.

This document is not intended as a substitute for a detailed study or operational and site-specific development or schematic plan. It is not to be used for determining suitability or reliability of the products/solutions for specific user applications. It is the duty of any such user to perform or have any professional expert of its choice (integrator, specifier or the like) perform the appropriate and comprehensive risk analysis, evaluation and testing of the products/solutions with respect to the relevant specific application or use thereof.

The Schneider Electric brand and any trademarks of Schneider Electric SE and its subsidiaries referred to in this document are the property of Schneider Electric SE or its subsidiaries. All other brands may be trademarks of their respective owner.

This document and its content are protected under applicable copyright laws and provided for informative use only. No part of this document may be reproduced or transmitted in any form or by any means (electronic, mechanical, photocopying, recording, or otherwise), for any purpose, without the prior written permission of Schneider Electric.

Schneider Electric does not grant any right or license for commercial use of the document or its content, except for a non-exclusive and personal license to consult it on an "as is" basis.

Schneider Electric reserves the right to make changes or updates with respect to or in the content of this document or the format thereof, at any time without notice.

**To the extent permitted by applicable law, no responsibility or liability is assumed by Schneider Electric and its subsidiaries for any errors or omissions in the informational content of this document, as well as any non-intended use or misuse of the content thereof.**

# Table of Contents

Safety Information.....	5
Safety Precautions.....	6
Cybersecurity.....	7
Introduction.....	7
Schneider Electric's Approach on Cybersecurity.....	7
Cyber Threats.....	8
Sources of Cyber Attacks.....	8
How Attackers Gain Access.....	8
Reporting and Management.....	9
Introduction.....	10
Active Harmonic Filter.....	10
Receiving, Handling, and Storing.....	11
Receiving.....	11
Handling.....	11
Storing.....	12
Installation.....	13
Foundation Preparation.....	14
Installation.....	14
Environmental Requirements.....	14
Physical Description.....	15
Physical Installation.....	15
Electrical Connection.....	35
Current Transformers.....	50
Parallel Communication.....	59
Control Wiring.....	61
Pre-commissioning.....	65
Instruments Required for Commissioning.....	65
Pre-energizing Procedure.....	65
Installation Inspection.....	65
Pre-Commissioning Checklist.....	65
Commissioning procedures.....	66
IP00/Chassis Installation.....	67
Dimensional Drawings.....	69
HMI Connections.....	73
Chassis to HMI/Front panel connections.....	74
24 Volt Power Connection.....	75
Ethernet.....	75
Communication.....	75
Enclosure mount USB.....	75



# Safety Information

## Important Information

**Read these instructions carefully and look at the equipment to become familiar with the device before trying to install, operate, service or maintain it. The following special messages may appear throughout this bulletin or on the equipment to warn of potential hazards or to call attention to information that clarifies or simplifies a procedure.**



The addition of either symbol to a "Danger" or "Warning" safety label indicates that an electrical hazard exists which will result in personal injury if the instructions are not followed.



This is the safety alert symbol. It is used to alert you to potential personal injury hazards. Obey all safety messages that follow this symbol to avoid possible injury or death.

### **DANGER**

**DANGER** indicates a hazardous situation which, if not avoided, **will result in death or serious injury.**

**Failure to follow these instructions will result in death or serious injury.**

### **WARNING**

**WARNING** indicates a hazardous situation which, if not avoided, **could result in death or serious injury.**

### **CAUTION**

**CAUTION** indicates a hazardous situation which, if not avoided, **could result in minor or moderate injury.**

### **NOTICE**

**NOTICE** is used to address practices not related to physical injury.

## Please Note

Electrical equipment should be installed, operated, serviced and maintained only by qualified personnel. No responsibility is assumed by Schneider Electric for any consequences arising out of the use of this material.

A qualified person is one who has skills and knowledge related to the construction, installation, and operation of electrical equipment and has received safety training to recognize and avoid the hazards involved.

# Safety Precautions

Installation, wiring, testing and service must be performed in accordance with all local and national electrical codes.

## DANGER

### HAZARD OF ELECTRIC SHOCK, EXPLOSION, OR ARC FLASH

- Apply appropriate personal protective equipment (PPE) and follow safe electrical work practices. See NFPA 70E in the USA, CSA Z462, or applicable local standards.
- This equipment must be installed and serviced only by qualified electrical personnel.
- Do not exceed the device's ratings for maximum limits.
- Ground equipment using the ground connecting point provided before turning on any power supplying this device.
- Turn off all power supplying this device and the equipment in which it is installed before working on the device or equipment.
- After removing power, wait for 15 minutes to allow the capacitors to discharge prior to opening the doors or removing covers.
- Always use a properly rated voltage sensing device to confirm power is off.
- Replace all devices, doors, and covers before turning on power to this equipment.
- Carefully inspect the interior for tools left behind before closing and sealing the door.
- Verify the rating of the neutral conductor for each unit in the system is greater than the neutral current limit setting.

**Failure to follow these instructions will result in death or serious injury.**

## WARNING

### POTENTIAL COMPROMISE OF SYSTEM AVAILABILITY, INTEGRITY, AND CONFIDENTIALITY

- Change default passwords at first use to help prevent unauthorized access to device settings and information.
- Disable unused ports/services and default accounts, where possible, to minimize pathways for malicious attacks.
- Place networked devices behind multiple layers of cyber defenses (such as firewalls, network segmentation, and network intrusion detection and protection).
- Use cybersecurity best practices (for example, least privilege, separation of duties) to help prevent unauthorized exposure, loss, modification of data and logs, interruption of services, or unintended operation.
- Restrict unit access to authorized personnel only.

**Failure to follow these instructions can result in death, serious injury, or equipment damage.**

# Cybersecurity

## Introduction

Cybersecurity is a branch of network administration that addresses attacks on or by PCs and through PC networks that can result in accidental or intentional disruptions. The objective of cybersecurity is to help provide increased levels of protection for information and physical assets from theft, corruption, misuse, or accidents while maintaining access for their intended users.

No single cybersecurity approach is adequate. Schneider Electric recommends a defense-in-depth approach. Conceived by the National Security Agency (NSA), this approach layers the network with security features, appliances, and processes. The basic components of this approach are:

- Risk assessment
- Security plan built on the results of the risk assessment
- Multi-phase training campaign
- Physical separation of the industrial networks from enterprise networks using a demilitarized zone (DMZ) and the use of firewalls and routing to establish other security zones
- System access control
- Device hardening
- Network monitoring and maintenance

This section defines elements that help you configure a system that is less susceptible to cyber attacks. For detailed information on the defense-in-depth approach, refer to the [Recommended Cybersecurity Best Practices on the Schneider Electric website](#).

## Schneider Electric's Approach on Cybersecurity

Schneider Electric adheres to industries best practice in the development and implementation of control systems. This includes a defense-in-depth approach to secure an industrial control system. This approach places the controllers behind one or more firewalls to restrict access to authorized personnel and protocols only.

<b>▲ WARNING</b>
<b>UNAUTHENTICATED ACCESS AND SUBSEQUENT UNAUTHORIZED OPERATION</b>
<ul style="list-style-type: none"><li>• Evaluate whether your equipment or complete environment are connected to your critical infrastructure. If so, take appropriate steps in terms of prevention, based on defense-in-depth, before connecting the automation system to any network.</li><li>• Limit the number of devices connected to a network inside your company.</li><li>• Isolate your industrial network from other networks inside your company.</li><li>• Protect any network against unintended access by using firewalls, VPN, or other, proven security measures.</li><li>• Monitor activities within your systems.</li><li>• Prevent subject devices from direct access or direct link by unauthorized parties or unauthenticated actions.</li><li>• Prepare a recovery plan including backup of your system and process information.</li></ul>
<b>Failure to follow these instructions can result in death, serious injury, or equipment damage.</b>

## Cyber Threats

Cyber threats are deliberate actions or accidents that can disrupt the normal operations of PCs and PC networks. These actions can be initiated from within the physical facility or from an external location. Security challenges for the control environment include:

- Diverse physical and logical boundaries.
- Multiple sites and large geographic spans.
- Adverse effects of security implementation on process availability.
- Increased exposure to worms and viruses migrating from business systems to control systems as business-control communications become more open.
- Increased exposure to malicious software from USB devices, vendor and service technician laptops, and the enterprise network.
- Direct impact of control systems on physical and mechanical systems.

## Sources of Cyber Attacks

Implement a cybersecurity plan that accounts for various potential sources of cyberattacks and accidents, including:

Source	Description
Internal	<ul style="list-style-type: none"> <li>• Inappropriate employee or contractor behaviour</li> <li>• Disgruntled employee or contractor</li> </ul>
External opportunistic (non-directed)	<ul style="list-style-type: none"> <li>• Script kiddies<sup>1</sup></li> <li>• Recreational hackers</li> <li>• Virus writers</li> </ul>
External deliberate (directed)	<ul style="list-style-type: none"> <li>• Criminal groups</li> <li>• Activists</li> <li>• Terrorists</li> <li>• Agencies of foreign states</li> </ul>
Accidental	

A deliberate cyber attack on a control system may be launched to achieve a number of malicious results, including:

- Disrupt the production process by blocking or delaying the flow of information.
- Damage, disable, or shut down equipment to negatively impact production or the environment.
- Modify or disable safety systems to cause intentional harm.

## How Attackers Gain Access

A cyber attacker bypasses the perimeter defenses to gain access to the control system network. Common points of access include:

- Dial-up access to remote terminal unit (RTU) devices.
- Supplier access points (such as technical support access points).
- IT-controlled network products.
- Corporate virtual private network (VPN).
- Database links.

1. Slang term for hackers who use malicious scripts written by others without necessarily possessing a comprehensive understanding of how the script works or its potential impact on a system

- Poorly configured firewalls.
- Peer utilities.

## Reporting and Management

To submit a cybersecurity question, report security issues, or to get the latest news from Schneider Electric , visit our [Schneider Electric Country website](#).

# Introduction

## Active Harmonic Filter

Active Harmonic Filters (AHF) are static power electronic products that employ digital logic and IGBT semiconductors to synthesize a current waveform that is injected into the electrical network to cancel harmonic currents caused by nonlinear loads. AHF employ current transformers to measure the load current to determine the content of harmonic current present. By injecting the synthesized current, network harmonic currents are greatly mitigated, thus reducing the heating effects of harmonic current and reducing voltage distortion.

AHF also have the ability to correct for poor displacement power factor (DPF) and for mains current balancing. DPF correction can be provided for either leading (capacitive) or lagging (inductive) loads that cause poor DPF. Mains current balancing is achieved by measuring the negative and zero sequence current present and injecting the inverse of those currents to balance the current for the upstream network.

PowerLogic™ AccuSine PCSn enclosures are available in an IP20 either as a wall mount or rack mount option, as well as IP42 and UL Type 1 wall mount. An IP00 open chassis is also available that can be installed in other types of enclosures such as motor control centers (MCC). The chassis can be installed vertically like the wall mount.

PowerLogic™ AccuSine PCSn can be powered by three phase conductors to provide corrective current for Line-to-Line connected loads or by three phase conductors and neutral to provide correction for Line-to-Line and Line-to-Neutral connected loads. The amount of correction can be selected to provide neutral current for up to three times the phase current correction. The neutral wiring must be sized appropriately based on the selected neutral current correction.

PowerLogic™ AccuSine PCSn can be either a main unit or an expansion unit. A minimum of one main unit is required per system. A main unit is easily identified as it is equipped with a HMI. The HMI permits viewing and changing parameter settings of complete system or any other unit in the parallel system. The unit has a means for connecting CT secondary wiring. Expansion units are also available to allow operating a system in parallel for additional capacity. Adding an expansion unit to a system only requires the connection of power cabling and a paralleling cable (shielded Cat 5e or greater).

# Receiving, Handling, and Storing

## Receiving

Inspect the active filter for any damage as soon as it is received. Transfer of the equipment to a carrier at any manufacturing plant or other shipping point constitutes delivery to the purchaser. Title and all risk of loss or damage in transit shall pass to the purchaser at that time, regardless of freight payment.

## Inspection

- Check that all packages and/or crates is delivered and that the equipment is not damaged in transit.
- In the event of damaged or missing items, contact the carrier immediately. Check with them for time limits for filing claims and any documentation required such as a bill of lading number, etc.
- Goods, whether sent freight pre-paid or not, are shipped at the consignee's risk.
- Damaged or missing items are the responsibility of the carrier and must be reported.
- Check that the information shown on the equipment nameplates corresponds with the order specifications.
- The packaging material must be replaced to protect the unit until installation has begun.

## Handling

### **▲ WARNING**

#### **HAZARD OF PERSONAL INJURY**

- Use proper lifting equipment such as an overhead crane to handle the active filter.
- Do not lay the equipment on its front.

**Failure to follow these instructions can result in death, serious injury, or equipment damage.**

Ensure that the proper equipment such as an overhead crane is available at the installation site to handle the active filter. This equipment will help avoid injury to personnel and damage to the active filter.

Verify the lifting capacity of the equipment being used to handle the active filter in accordance with the shipping weight of each shipping section.

### **NOTICE**

#### **RISK OF EQUIPMENT DAMAGE**

For UL Type 1 models, use lifting eye-bolts provided on the unit to remove it from the shipping crate. Do not lift the unit by its ends.

**Failure to follow these instructions can result in equipment damage.**

## Storing

If the active filter is not to be installed when unpacked, it should be stored indoors in a clean, dry place. The storage temperature must be between -20 °C (-4 °F) and 60 °C (140 °F) with a maximum relative humidity of 85%, non-condensing, and a maximum dew-point of 37 °C (98.6 °F). It is preferable to store the unit in its original shipping container to protect the unit from potential damage.

# Installation

This chapter provides the information required to properly install the active filter and associated equipment for proper operation and performance. Frequently, commissioning difficulties are the result of incorrect wiring. Every precaution must be taken to assure that the wiring is done as instructed. Read and understand all instructions in this manual prior to installation.

Correct installation of the active filter is essential for proper operation of all components. Study the associated instruction books and all drawings carefully.

The location chosen for installation should provide working clearances complying with the appropriate section of the National Electrical Code® (NEC®), the Canadian Electrical Code (CEC), or applicable local standards.

## DANGER

### HAZARD OF ELECTRIC SHOCK, EXPLOSION, OR ARC FLASH

- Apply appropriate personal protective equipment (PPE) and follow safe electrical work practices. See NFPA 70E in the USA, CSA Z462, or applicable local standards.
- This equipment must be installed and serviced only by qualified electrical personnel.
- Do not exceed the device's ratings for maximum limits.
- Ground equipment using the ground connecting point provided before turning on any power supplying this device.
- Turn off all power supplying this device and the equipment in which it is installed before working on the device or equipment.
- Do not stand on any part of the active filter.
- After removing power, wait for 15 minutes to allow the capacitors to discharge prior to opening the doors or removing covers.
- Always use a properly rated voltage sensing device to confirm power is off.
- Replace all devices, doors, and covers before turning on power to this equipment.
- Carefully inspect the interior for tools left behind before closing and sealing the door.

**Failure to follow these instructions will result in death or serious injury.**

The following is a summary of the steps for installation covered in this chapter:

- Make sure that the line voltage is compatible with the voltage rating of the active filter.
- Make sure that the foundation is prepared for the active filter.
- Make sure that environmental requirements are satisfied.
- Refer to the dimensional drawings for the active filter to be installed.
- Mount the unit in the desired location.
- Make the electrical connections.
- Make the CT to CT board connection.
- Set up parallel communication if applicable.
- Make the control wiring connections, but do not energize the active filter yet.

**NOTE:** Commissioning and energizing the active filter requires specialized knowledge. Pre-commissioning procedures are covered in Pre-commissioning. Commissioning procedures are covered in the User Manual. Commission the active filter and energize it only if you are qualified to do so.

## Foundation Preparation

The mounting location must be able to support the weight of the unit without sagging.

## Installation

For optimum performance in harmonic mitigation mode, adhere to the following recommendations:

- All harmonic generating loads must have a minimum 3% line reactor or 3% DC choke installed.
- Notch depth: 10%, Notch area (AN): 13,667 V $\mu$ s @ 400 V as per IEEE 519-2014, Annex C.
- No capacitors downstream of the Main CTs.

### **NOTICE**

#### **RISK OF EQUIPMENT DAMAGE**

Adhere to DC choke, SCR based rectifier, and capacitor placement requirements.

**Failure to follow these instructions can result in equipment damage.**

If these recommendations are not followed, the target harmonic level may not be met and equipment damage can occur.

## Environmental Requirements

Active filters are designed for indoor use only. They require unrestricted exchange of environmental air to the inside of the enclosure for proper cooling. Make sure that the environment meets Pollution Degree 2, that is, it does not contain conductive particles, significant amounts of dust, or corrosive or otherwise harmful gases. Normally only non-conductive pollution occurs. Temporary conductivity caused by condensation is to be expected.

### **NOTICE**

#### **RISK OF EQUIPMENT DAMAGE**

Ensure that the installation location satisfies environmental requirements.

**Failure to follow these instructions can result in equipment damage.**

If environmental requirements are not adhered to, malfunction and possible destruction of the active filter may occur.

The active filter generates significant heat during operation. Consult the product specifications in the table below for the watt losses for each active filter model. Ensure that the room where the active filter is mounted has adequate ventilation. Maintain ambient temperature between 0 °C (32 °F) and 45 °C (113 °F) with a maximum relative humidity of 95%, non-condensing, and a maximum dew-point of 37 °C (98.6 °F).

The operating temperatures are maximum and minimum levels the unit is designed to operate within. Operating above or below these levels will result in the unit either shutting down or reduced performance. The upper or lower limit should not be used as ideal room temperature levels. System reliability and product life expectancy will improve if temperature levels are maintained between 20 °C (68 °F) and 30 °C (86 °F).

## Physical Description

### Physical Description IP42, IP20 and IP00

PowerLogic™ AccuSine PCSn model	Amperage Rating	Mounting Style	Cable Entry	Typical Heat Load 415 V (W)	Mass (kg)	Air Flow (m3/h)	Exterior Dimensions H x W x D (mm)
PCSN060Y4W42	60	IP42 Wall	Bottom	1500	131.5	560	1385 x 542 x 375
PCSN020Y4W20	20	IP20 Wall	Bottom	530	61	560	960 x 440 x 282
PCSN030Y4W20	30	IP20 Wall	Bottom	750	61	560	960 x 440 x 282
PCSN050Y4W20	50	IP20 Wall	Bottom	1200	75	560	960 x 440 x 282
PCSN060Y4W20	60	IP20 Wall	Bottom	1500	75	560	960 x 440 x 282
PCSN060Y4W20E	60	IP20 Wall	Bottom	1500	75	560	960 x 440 x 282
PCSN030Y4R19	30	IP20 Rack	Front	750	61	560	264 x 440 x 960
PCSN060Y4R19	60	IP20 Rack	Front	1500	75	560	264 x 440 x 960
PCSN060Y4R19E	60	IP20 Rack	Front	1500	75	560	264 x 440 x 960
PCSN060Y4RCH	60	IP20 Rack	Front	1500	75	560	264 x 440 x 960
PCSN020Y4CH00	20	IP00 Chassis	Bottom	530	61	560	960 x 440 x 282
PCSN030Y4CH00	30	IP00 Chassis	Bottom	750	61	560	960 x 440 x 282
PCSN050Y4CH00	50	IP00 Chassis	Bottom	1200	75	560	960 x 440 x 282
PCSN060Y4CH00	60	IP00 Chassis	Bottom	1500	75	560	960 x 440 x 282
PCSN060Y4CH00E	60	IP00 Chassis	Bottom	1500	75	560	960 x 440 x 282

### Physical Description UL Type 1 Wall Mount

PowerLogic™ AccuSine PCSn model	Amperage Rating	Mounting Style	Cable Entry	Typical Heat Load 415 V (W)	Mass (kg)	Air Flow (m3/h)	Exterior Dimensions H x W x D (mm)
PCSN020Y4N1	20	UL Type 1 Wall	Bottom	365/530	74	560	1440 x 450 x 285
PCSN030Y4N1	30	UL Type 1 Wall	Bottom	600/750	74	560	1440 x 450 x 285
PCSN050Y4N1	50	UL Type 1 Wall	Bottom	970/1200	89	560	1440 x 450 x 285
PCSN060Y4N1	60	UL Type 1 Wall	Bottom	1265/1500	89	560	1440 x 450 x 285
PCSN060Y4N1E	60	UL Type 1 Wall	Bottom	1265/1500	89	560	1440 x 450 x 285

**NOTE:** Mass information is approximate and subject to change without notice.

## Physical Installation

The active filter can be provided as a wall mount IP20, IP42 and UL Type 1, rack mount IP20 or Open/IP00 chassis unit.

Enclosure Type	IP00	UL Type 1	IP20	IP42
Enclosure provided	No	Yes	Yes	Yes
Standard Compliance: UL 508	No	Yes	No	No
Standard Compliance: IEC60529	Yes	Yes	Yes	Yes
Protection against intake of dust, and harmful particles	No	No	No	No
Complete protection against touch	No	Yes	Yes	Yes
Protection against dripping water and external condensation of non-corrosive liquids	No	No	No	No
EMC/RFI certification	Yes	Yes	Yes	Yes

**NOTE:** This list indicates minimum requirements. Complete description of the requirements are provided in the standards referenced in this list.

## Dimensional Drawings

Refer to the drawings on the following pages for dimensions of the active filter to be installed.

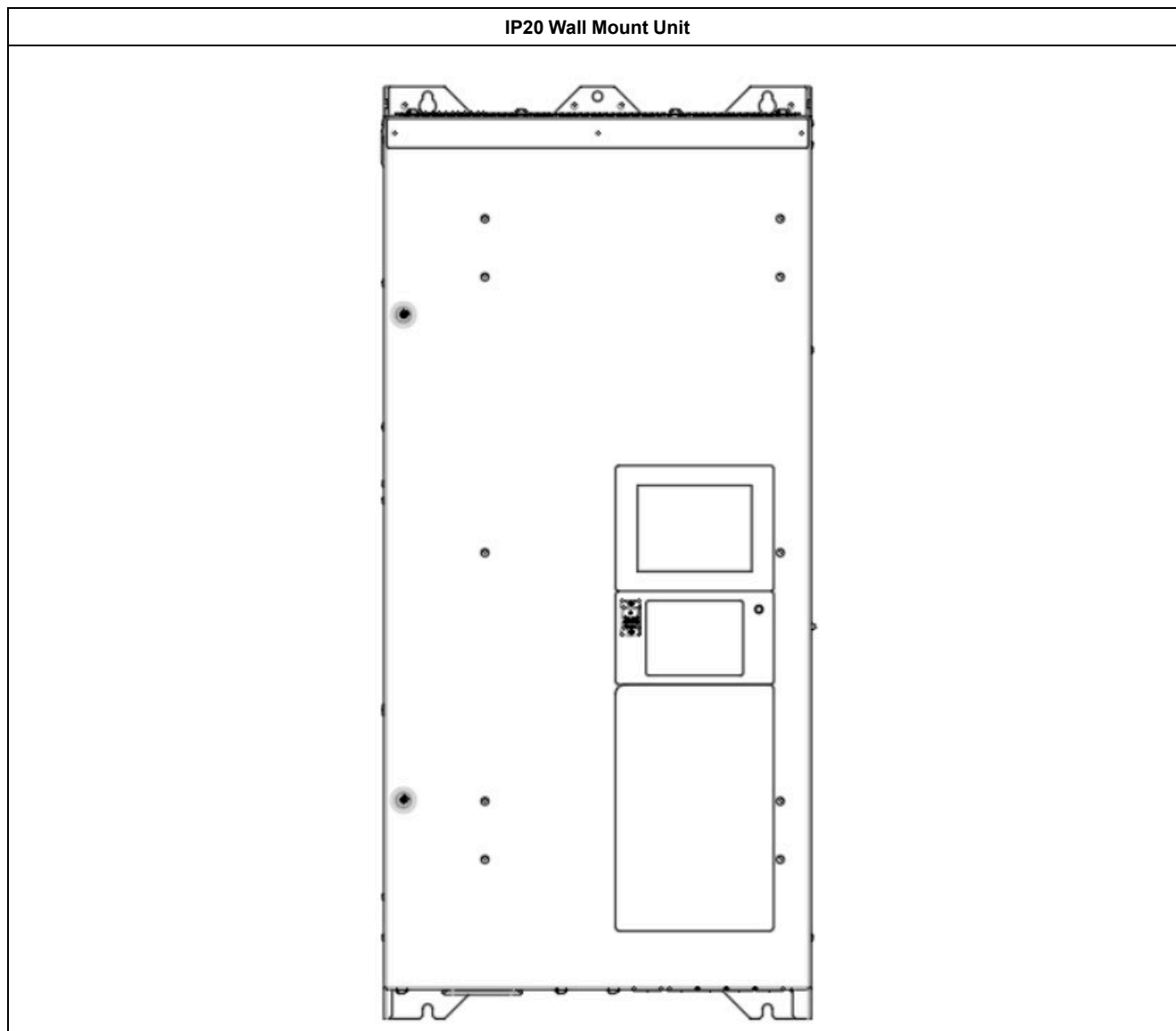

Total height including mounting features 960 mm Zero side clearance

Enclosure height 930 mm

Width 440 mm

Zero side clearance

Top and bottom clearance 200 mm

**IP20 Wall Mount Top View**

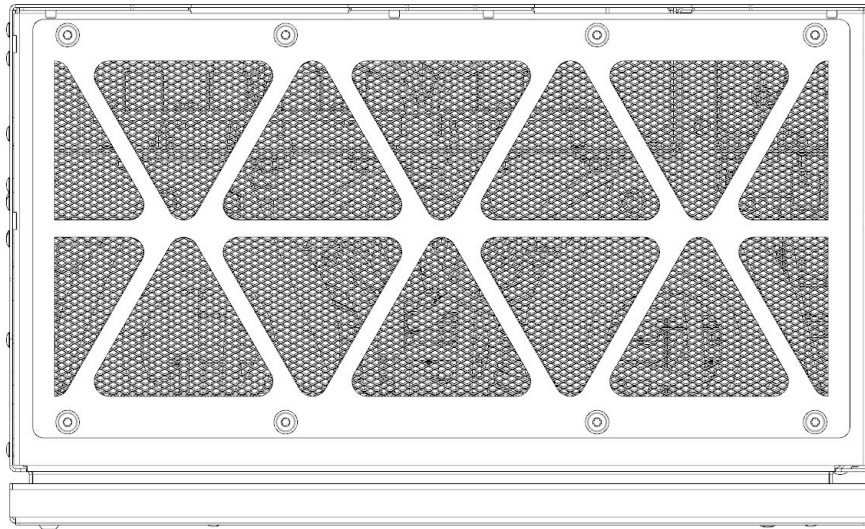

Depth 264 mm

Depth including HMI 282 mm

**IP20 Wall Mount Bottom View**

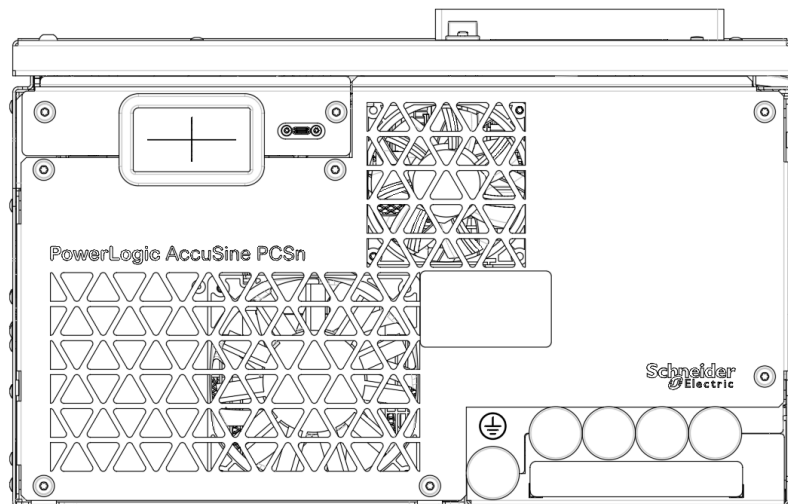

Depth 264 mm

Depth including HMI 282 mm

**IP20 Wall Mount Hole Dimensions (mm)**

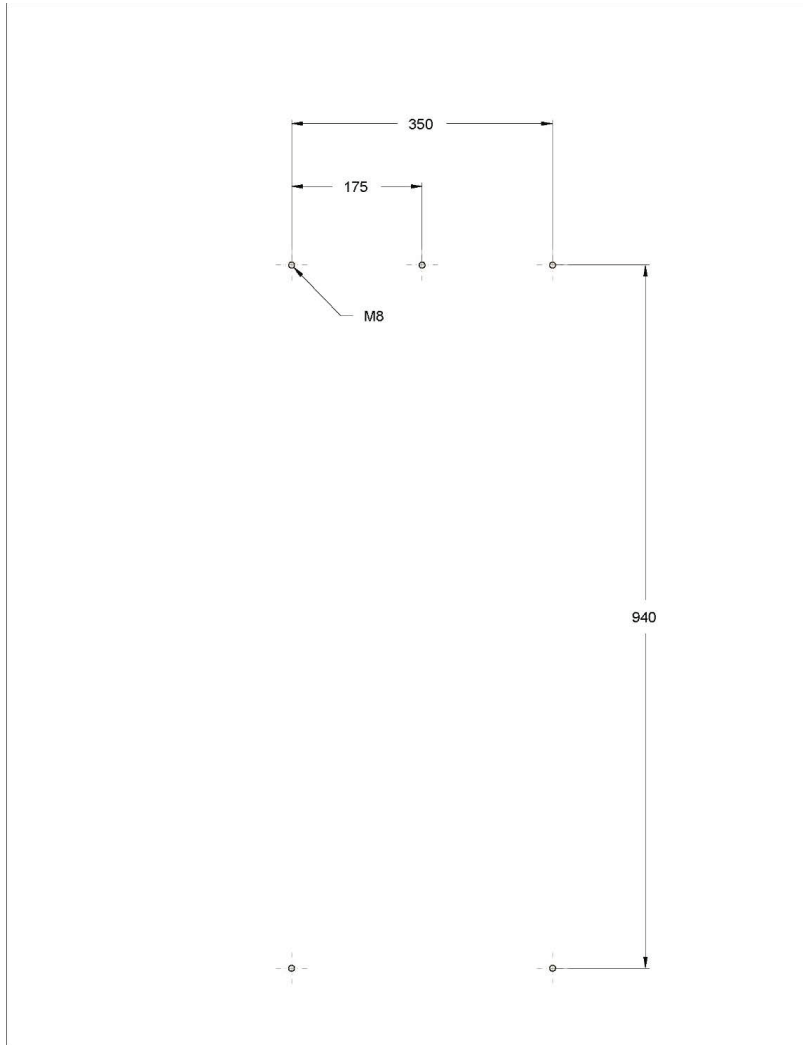

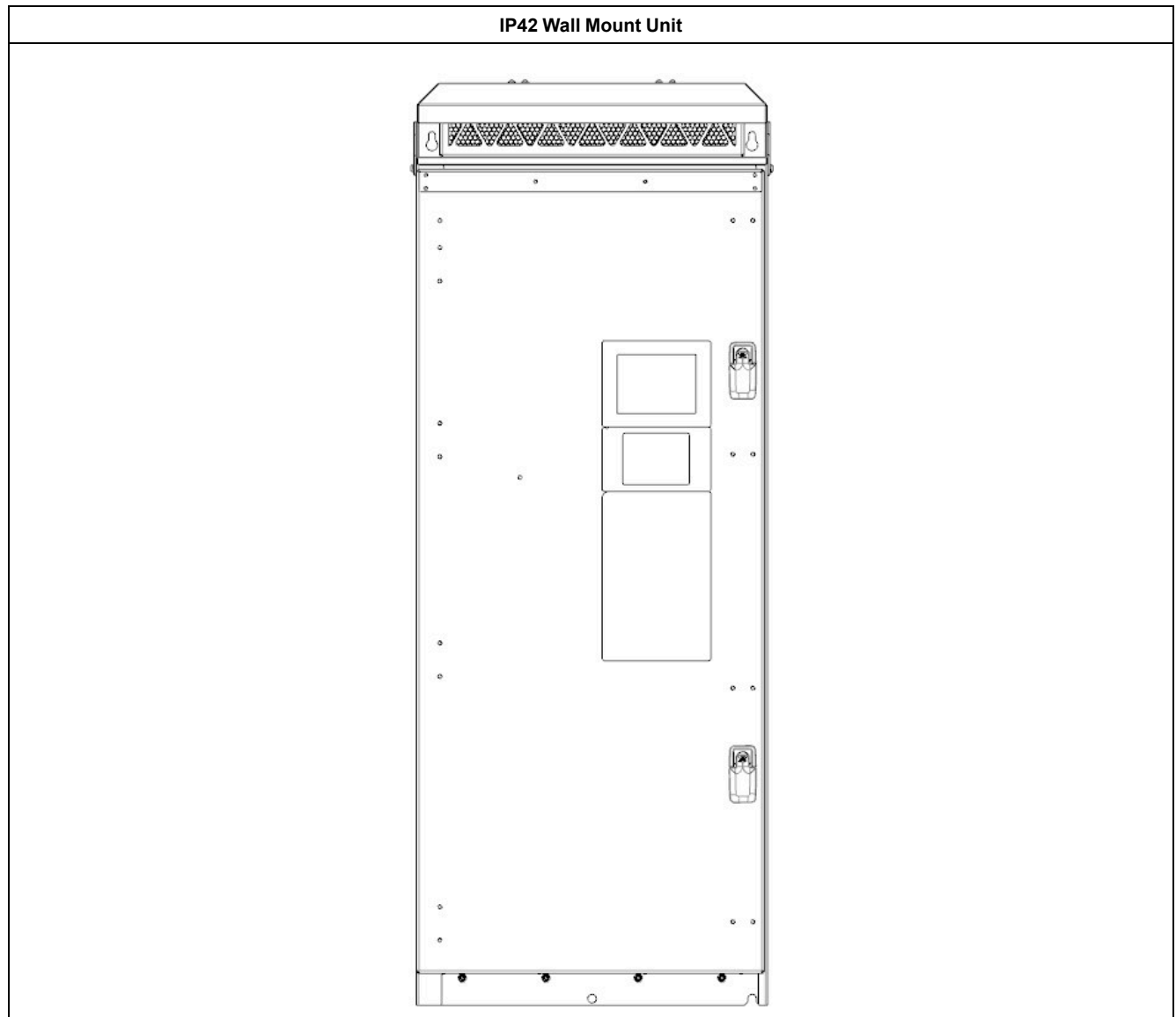

Total height including mounting features 1385 mm

Enclosure height 1222 mm

Width 525 mm

Zero side clearance

Top and bottom clearance 200 mm

Follow the below steps to open the PCSn IP42 Enclosure Door:

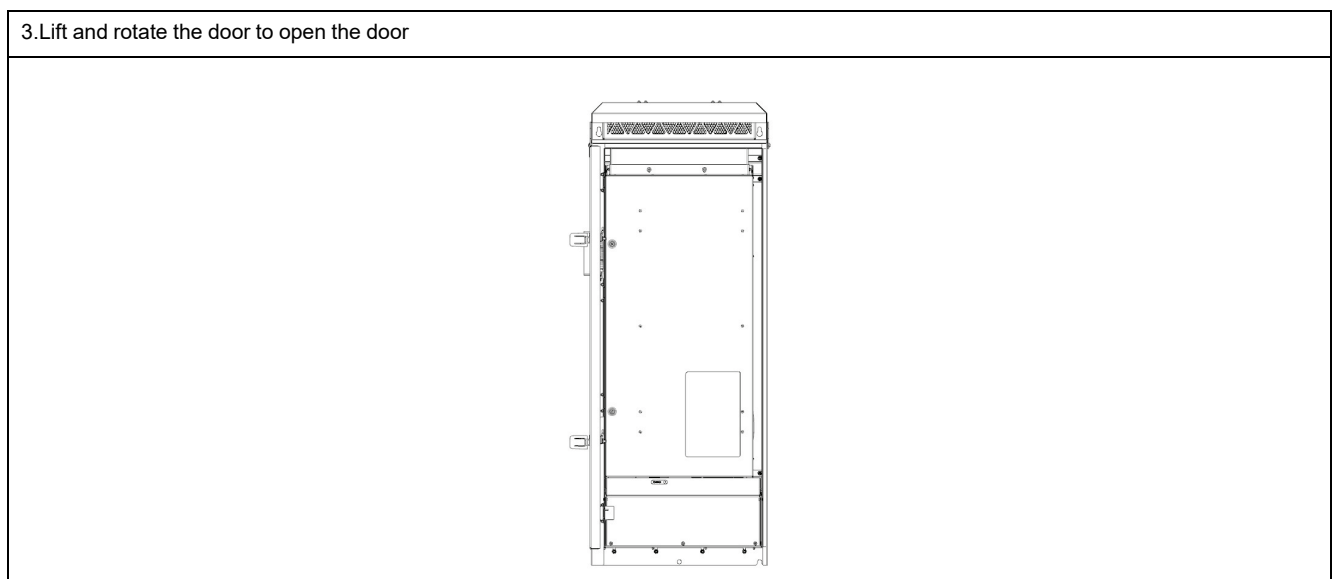
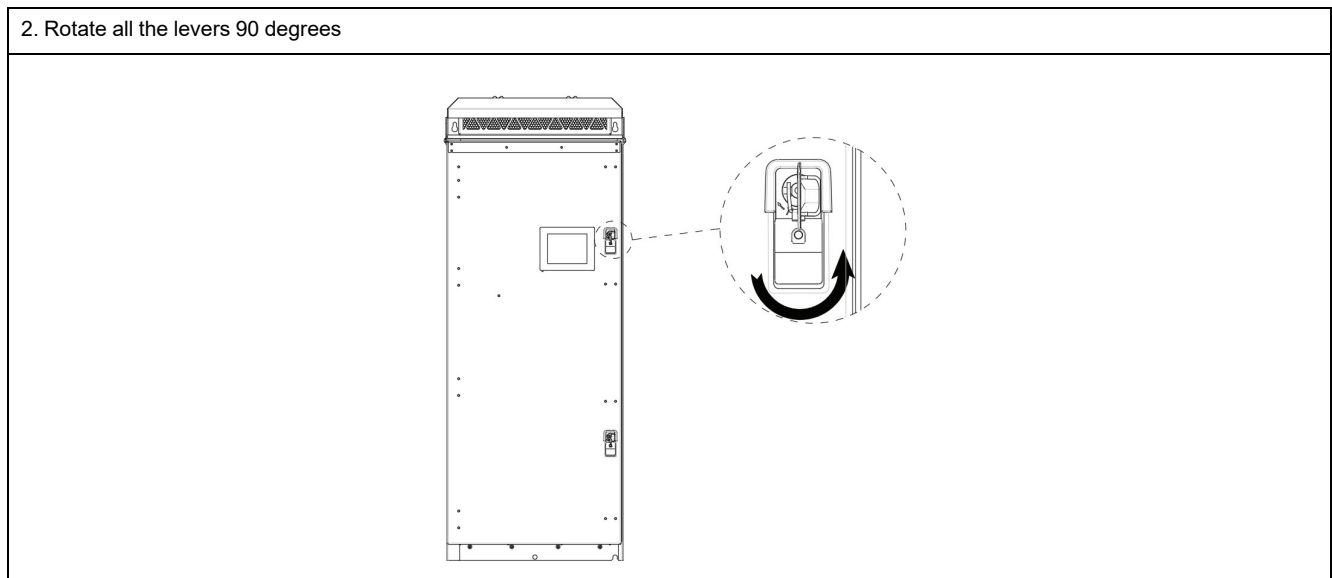
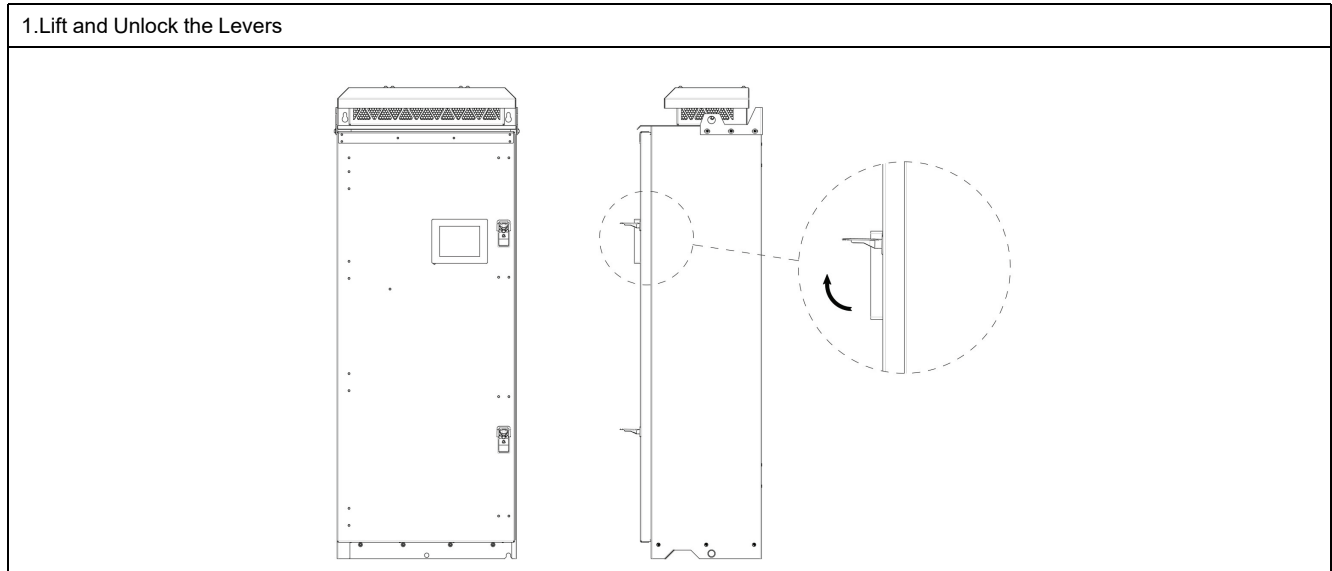

Service USB for PCSn IP42

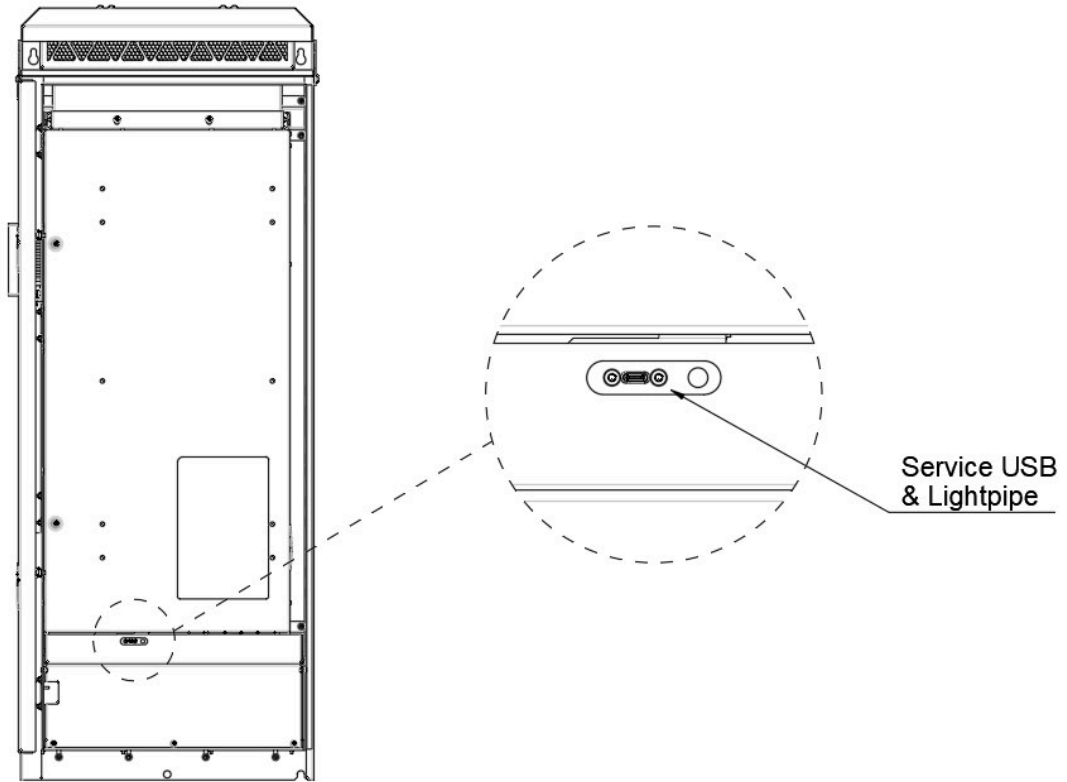

IP42 Wall Mount Top View

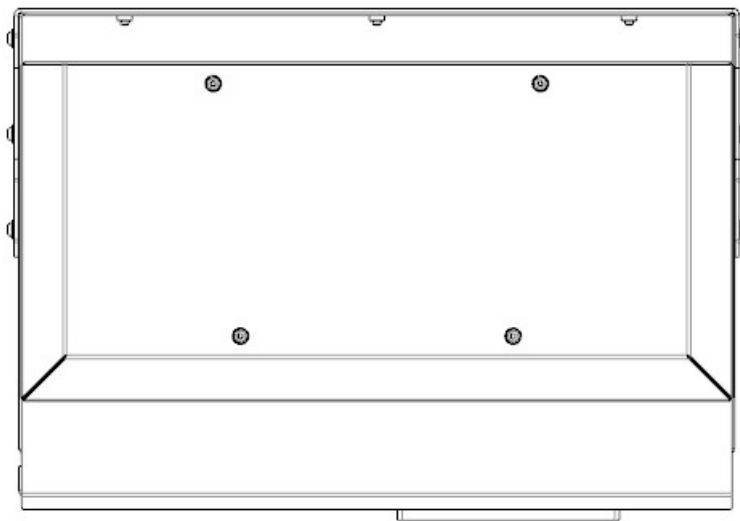

Depth 359 mm

Depth including HMI 375 mm

IP42 Wall Mount Bottom View

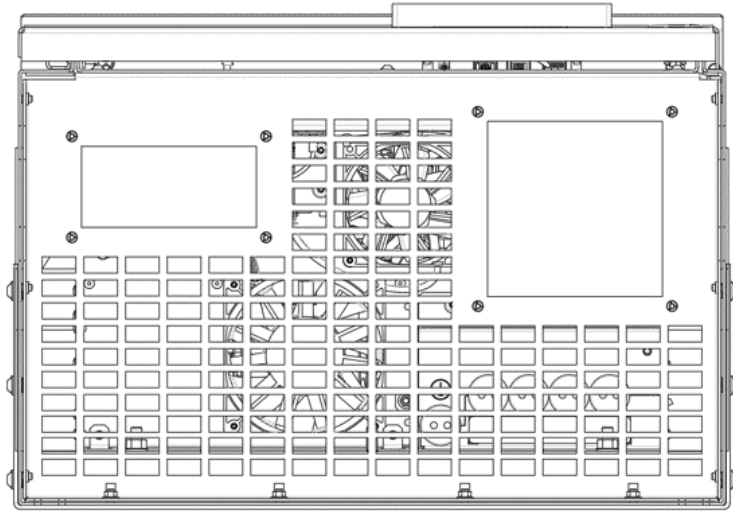

Depth 359 mm

Depth including HMI 375 mm

IP42 Wall Mount Hole Dimensions (mm)

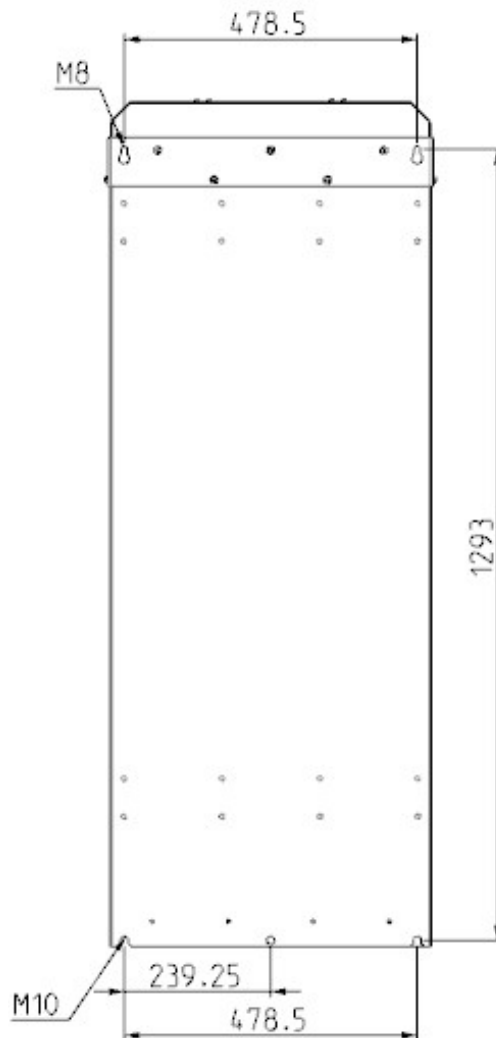

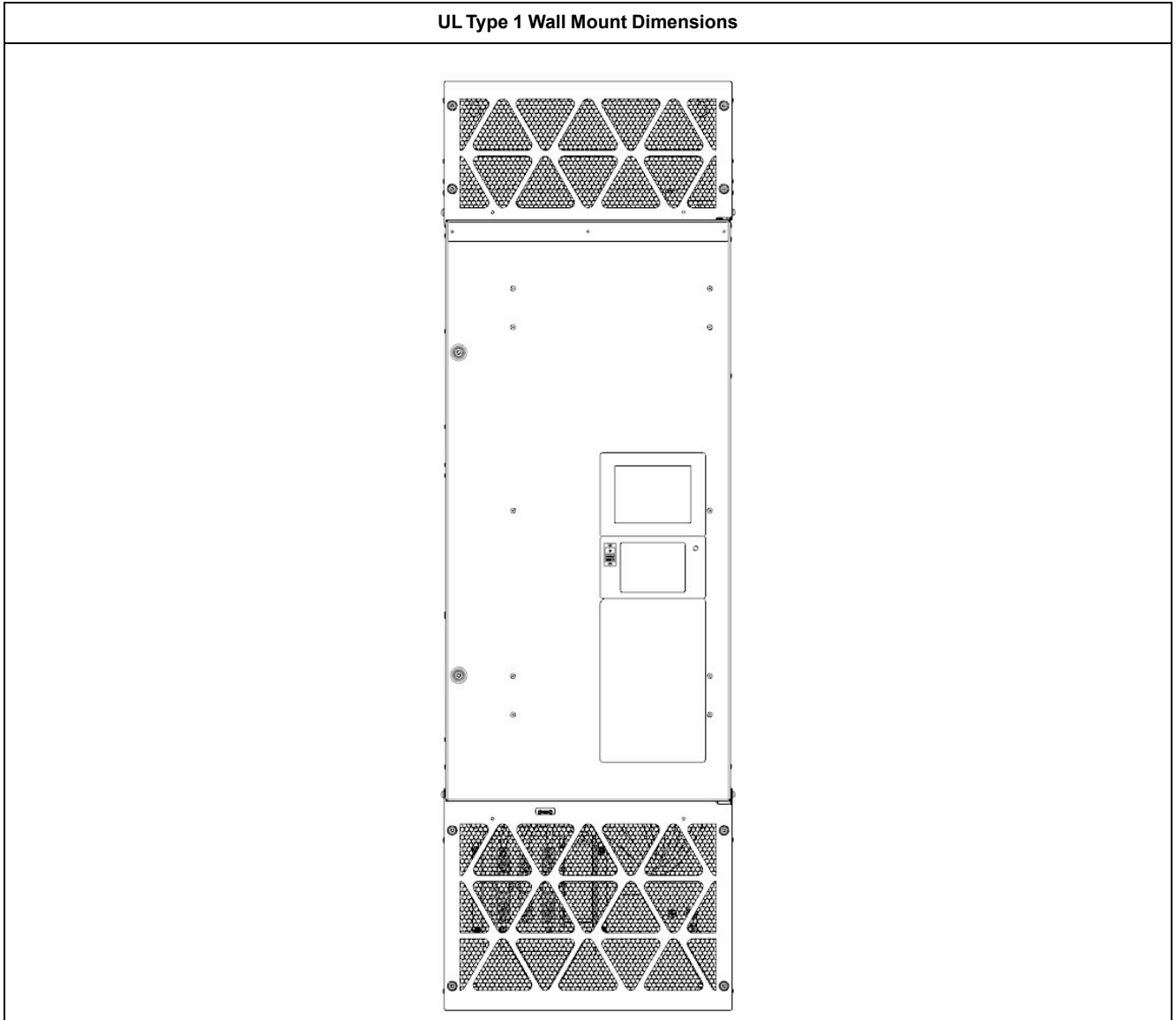
**UL Type 1 Wall Mount Dimensions**

Height 1440 mm

Width 450 mm

Depth 282 Main Unit

Depth 264 Expansion Unit (no HMI required)

Top and bottom clearance 200 mm

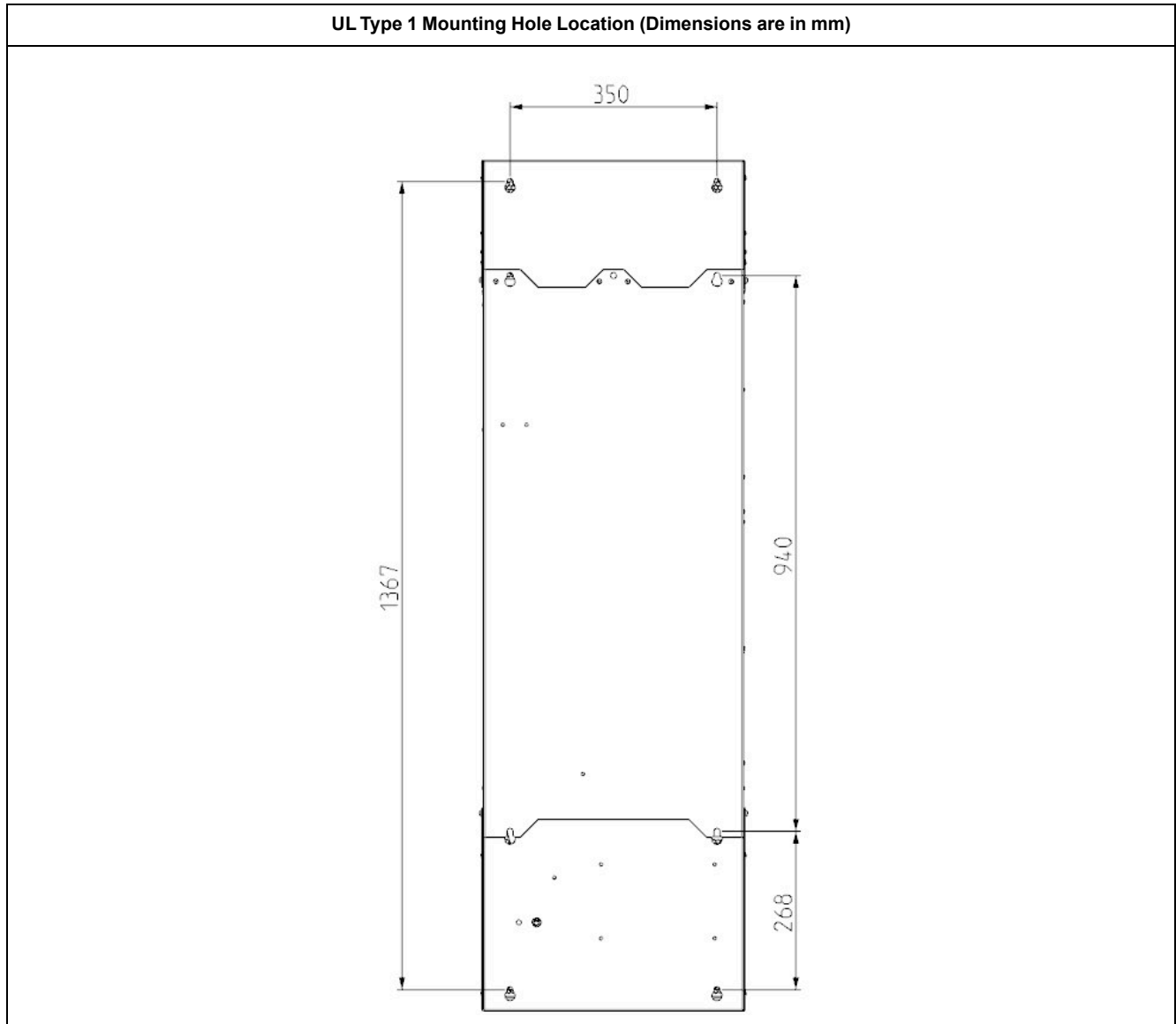

It is mandatory to use the chassis mounting holes. Refer to IP20 Wall Mount Hole Dimensions (mm) for information on chassis mounting hole location. When installing the unit in locations that experience vibration or that require additional mounting holes, it is recommended to add the UL Type 1 mounting holes.

**Rack Mount Main Unit Front View Dimensions**

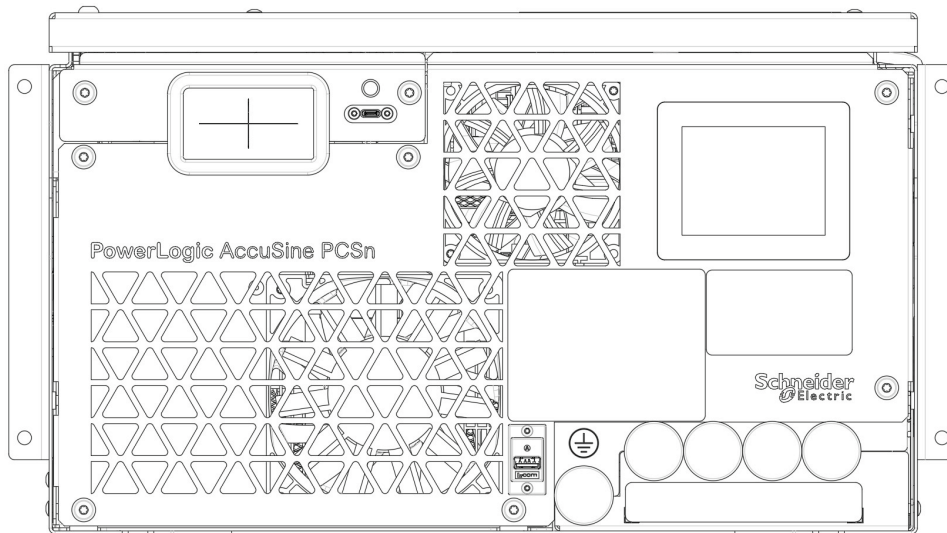

Height 264 mm (6U)

Width 440 mm

**Rack Mount Main Unit Top View Dimensions**

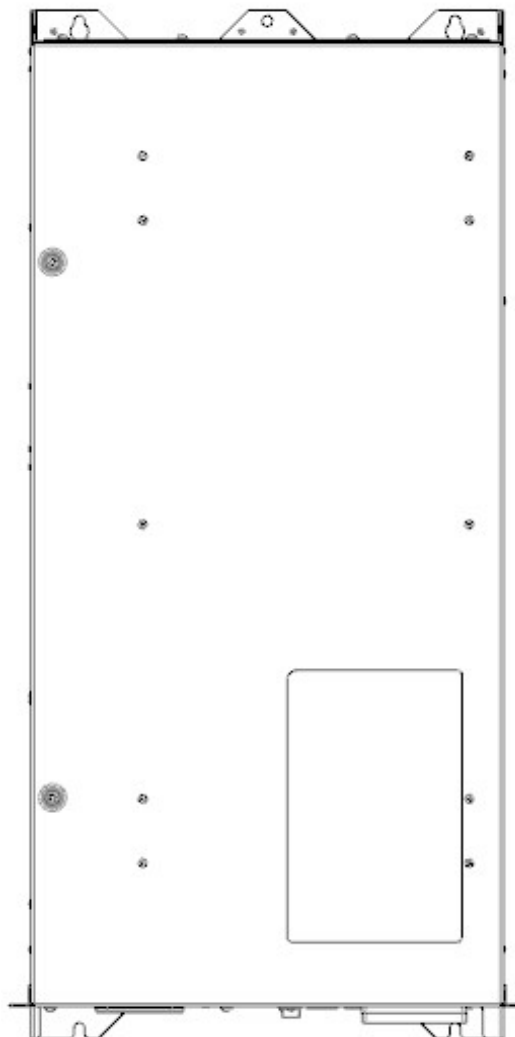

Depth 960 mm

Airflow clearance 300 mm front and back clearances must comply with national and local codes. A minimum 1 meter front clearance is recommended for service.

The Rack mount version of the active filter is designed to be installed in a standard 42U enclosure. The Unit has a height of 6U with the 1U cable management plate the total height is 7U. This allows for a total of 6 units to be installed in a single 42U enclosure. All rack mount accessories have been designed to work with Schneider Electric's NetShelter enclosures SKU AR3100 and AR3300.

The NetShelter enclosures with the standard doors have been validated to provide adequate airflow for the PowerLogic™ AccuSine PCSn product line. Refer to the Enclosure Installation Manual for installation and cabling requirements.

Always use blanking panels to fill empty vertical spaces in the rack to maintain proper airflow. Using a rack without blanking panels results in improper cooling that can lead to thermal damage. If any of the vertical space in the rack is not filled by components, the gaps between components cause a change in airflow through the rack and across the components. Cover these gaps with blanking panels to maintain proper airflow. The blanking plates reference numbers are available in the PowerLogic™ AccuSine PCSn catalogue.

Rack Mount Main Control Unit

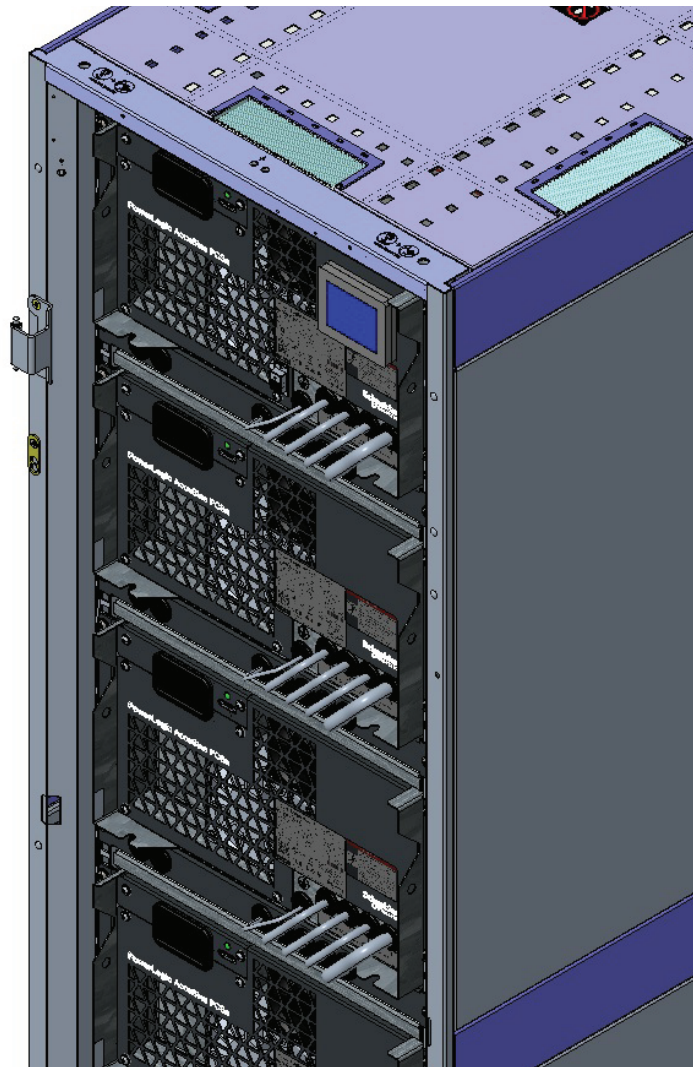

## **NOTICE**

### **RISK OF RECIRCULATING AIRFLOW**

Add blanking panels to fill empty vertical spaces in the rack.

**Failure to follow this instruction can result in reduced performance.**

Rack mounting installation rails and cable management plate are provided with each rack mount unit.

The unit must be installed with the shelf rails which have been designed to support the weight of the PowerLogic™ AccuSine PCSn.



The enclosure vertical mounting flanges must be located 737 mm apart for proper installation of the rack mounting rails.

The cable management plate provides a means to connect all wiring into the front of the active filter. Using a punch or similar, create a hole in the grommet just large enough to allow the CT, control wiring, line, ground and neutral (if required) wires to pass through the grommets. Mount the cable management plate below the unit.

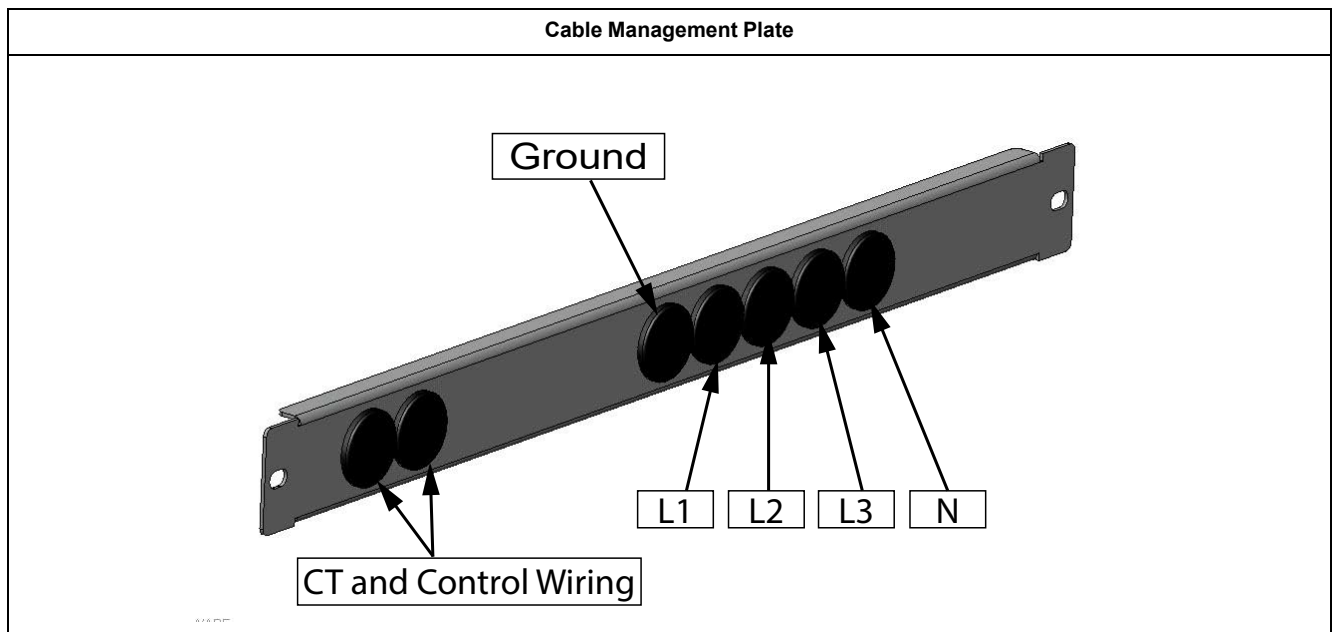

Prior to installing the Main unit into the enclosure, open the top service access door.

Remove the CT plug from the CT board and if needed, the I/O control wiring plug (J2) from the Control Board using a small flat tip screw driver. Retain the plugs to connect the CT's and I/O as needed.

#### Control Board and CT Board Details

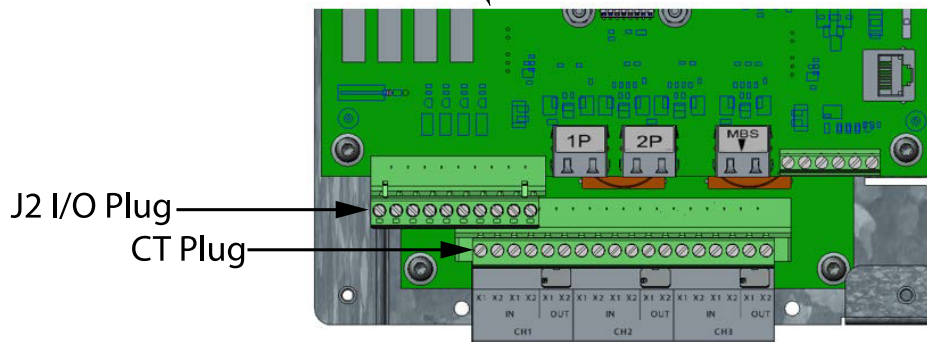
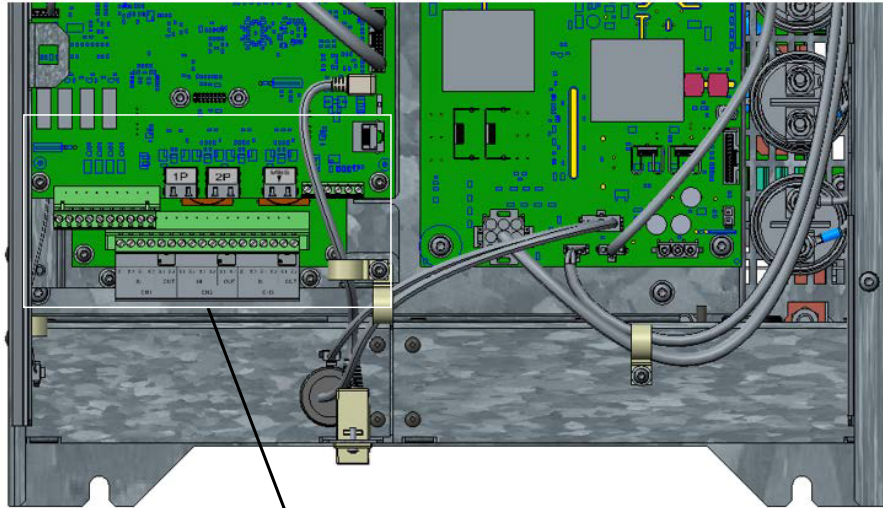

Use the mounting support brackets to secure the PowerLogic™ AccuSine PCSn to the enclosure. For seismic applications, additional hardware may be required. For more information, contact Schneider Electric representative.

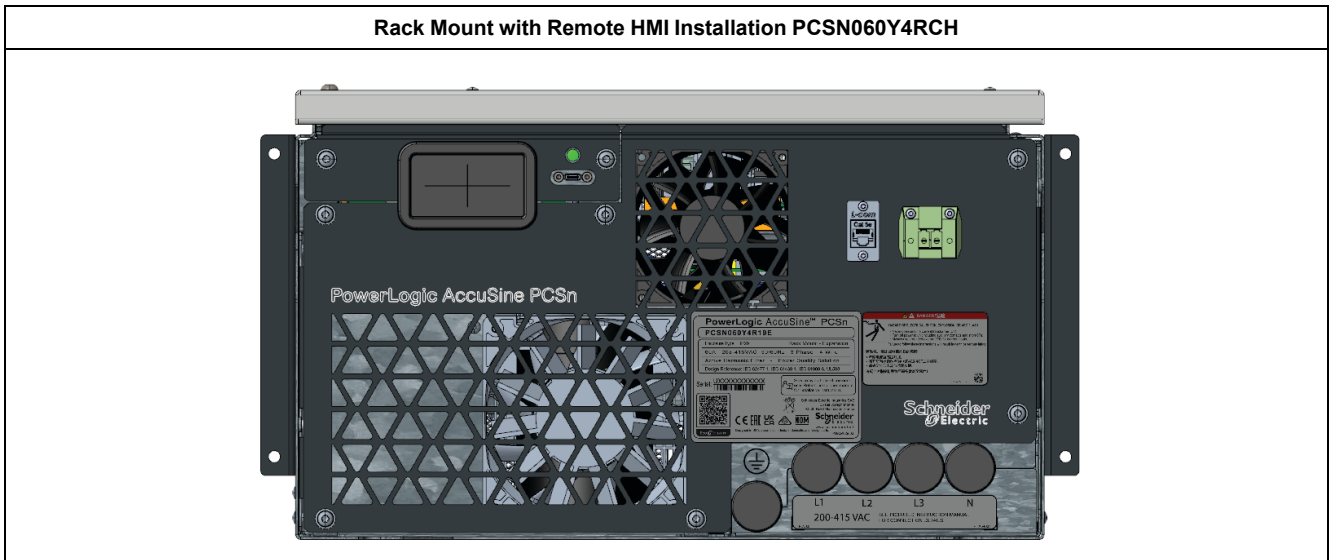
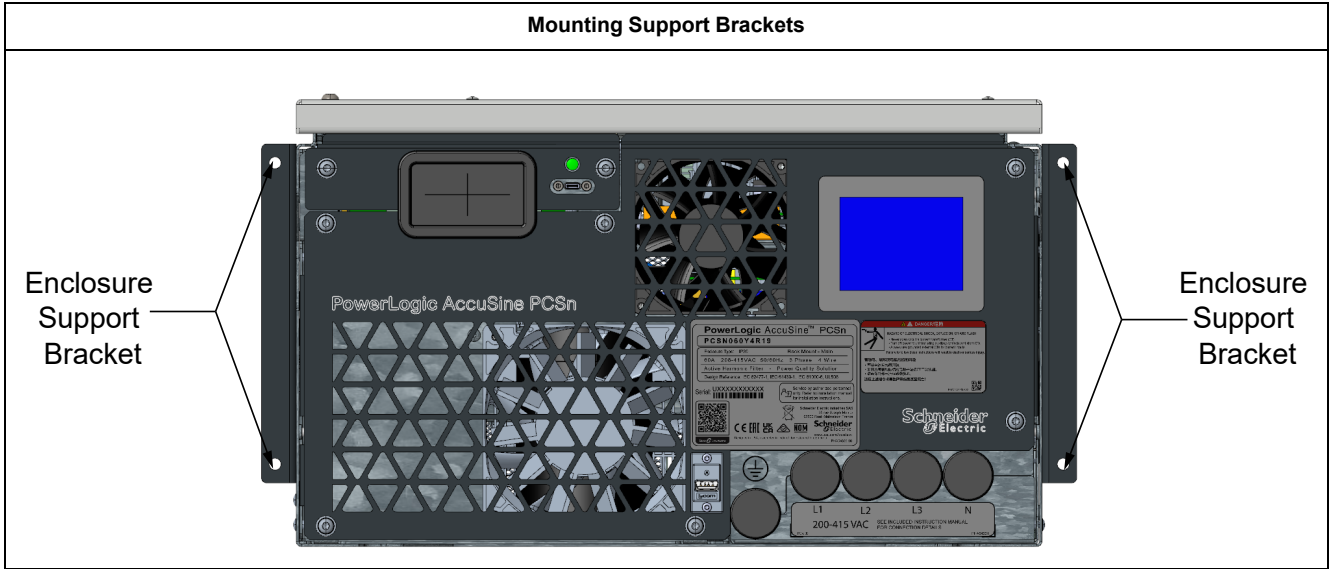

Unit includes HMI and cable kit that has Cat5e cable and power cable. HMI and power cable are 1.5 meters long.

General information on the installation of the HMI is provided below. For full details on the HMI and installation see the manual included in the HMI box.

**HMI Specifications**

Specification	PCSPHMISTU885
Ambient operating temperature (cabinet interior and panel face)	0...+50 °C (32...122 °F)
Storage temperature	-20...+60 °C (-4...140 °F)
Relative Humidity	85 % w/o condensation (Non-condensing, wet bulb temperature 39 °C (102.2 °F) or less)
Air purity (dust)	≤ 0.1 mg/m <sup>3</sup> (10-7 oz/ft <sup>3</sup> ) (non-conductive levels)
Corrosive gases	Free of corrosive gases
Atmospheric pressure	800 hPa to 1,114 hPa (2000 m (6,561 ft) or lower)

## Panel Setup Procedure

Mount the unit in an enclosure that provides a clean, dry, robust and controlled.

Before installing the HMISTU655/HMISTU855 verify that:

- The gasket is flat and not damaged.
- The installation panel or cabinet surface is flat (planarity tolerance: 0.5 mm (0.019 in)), in good condition and has no jagged edges. Metal reinforcing strips may be attached to the inside of the panel, near the panel cut-out, to increase the rigidity.
- The panel must be designed to avoid any induced vibration resonance on the rear module exceeding a punctual factor of 10 and to avoid any induced permanent vibration resonance. To reduce the resonance, use the panel adaptor accessory.
- The ambient operating temperature and the ambient humidity are within their specified ranges.
- The heat from surrounding equipment does not cause the unit to exceed its specified operating temperature.

## Inserting a HMI Without an Anti-rotation Tee

Create a panel cut-out and insert the display module of the unit into the panel from the front. The following illustration shows the panel cut-out for a HMI unit without a tee:

**HMI Unit without Tee**

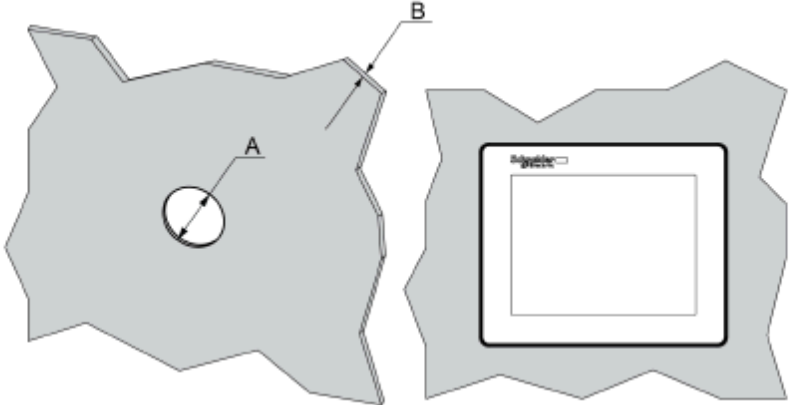

**Dimensions**

Unit	A (mm)	A (in.)	B (1)	B (2)
HMISTU655/855	+0 22.50 -0.30	+0 0.88 -0.01	1.5...6 mm ( 0.06...0.23 in.)	3...6 mm (0.11...0.23 in.)

(1) Steel sheet  
(2) Glass fiber reinforced plastics (minimum GF30)

**NOTE:** Without the tee option, the rotating torque that can be supported by the display module is 2.5 Nm (22.12 in-lb).

## Inserting a HMI with an Anti-rotation Tee

Create a panel cut-out and insert the display module of the unit into the panel from the front. The following illustration shows the panel cut-out for a HMI unit using a tee:

**HMI Unit with Tee**

**Dimensions**

Unit	C (mm)	C (in.)	D (mm)	D (in.)
HMISTU655/855	+0 30.00 -0.20	+0 1.18 -0.007	+0 4.00 -0.20	+0 0.15 -0.007

**NOTE:** With the tee option, the rotating torque that can be supported by the display module is 6 Nm (53.10 in-lb).

The support thickness depends on the material:

- Metallic: between 1.5 and 6 mm (0.059 and 0.236 in)
- Plastic: between 3 and 6 mm (0.118 and 0.236 in)

If the thickness is between 1 and 1.5 mm (0.039 and 0.059 in) for metallic support or 1 and 3 mm (0.039 and 0.118 in) for plastic, use the panel adaptor supplied in accessory kit HMIZSUKIT.

The Panel Adaptor, supplied in the accessory kit (HMIZSUKIT), allows mounting the product on a:

- Metallic support with a thickness between 1 and 1.5 mm (0.039 and 0.059 in)
- Plastic support with a thickness between 1 and 3 mm (0.039 and 0.118 in) for HMISTU655
- Glass fiber reinforced plastic with a thickness between 2 and 3 mm (0.078 and 0.118 in) for HMISTU855

The following illustration shows the assembly with the panel adaptor:

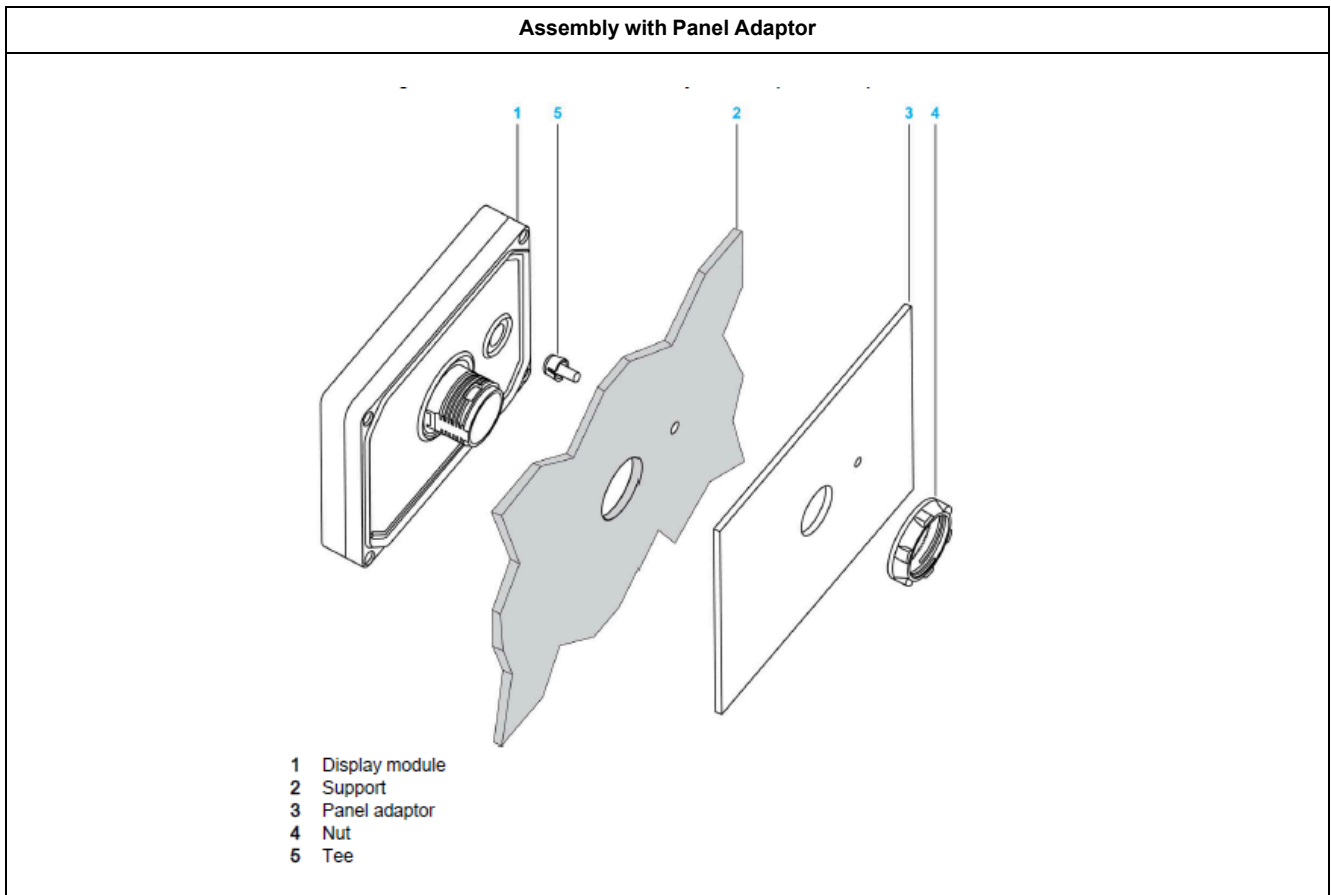

Insert the display module (with Tee, if used) into the panel hole:

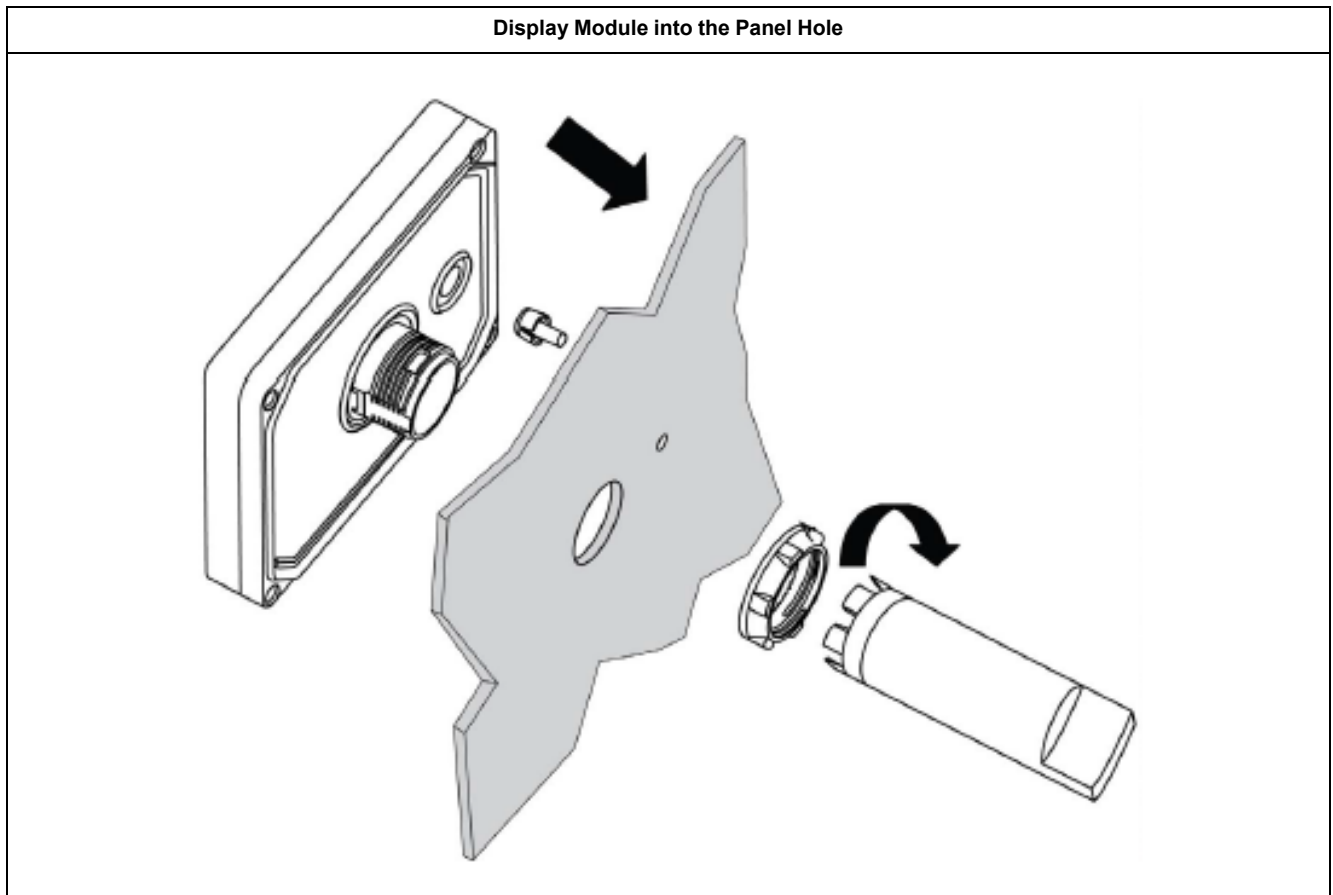

Screw the nut with the tightening wrench with a torque between 1.2 and 2 Nm (10.62 and 17.70 in-lb).

To install front and rear modules together, insert and push the rear module until it locks into place:

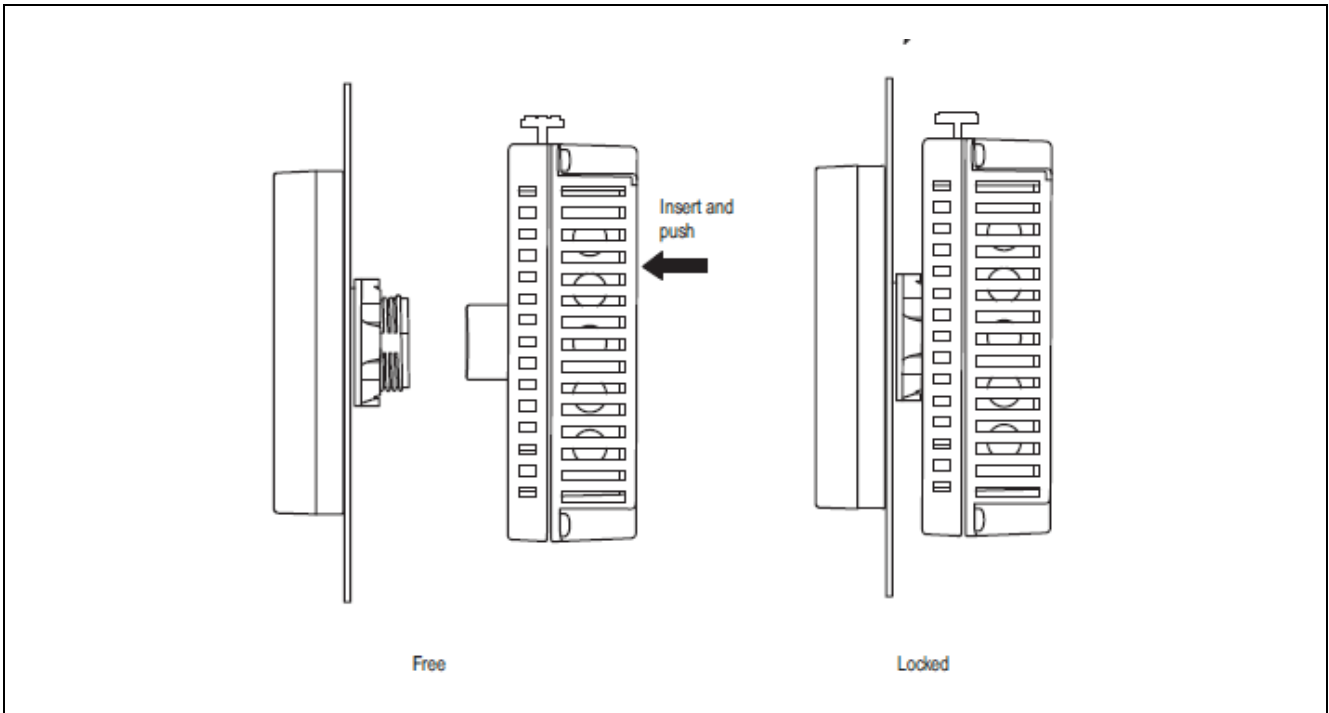

Electrical connection of HMI to the rack mount unit.

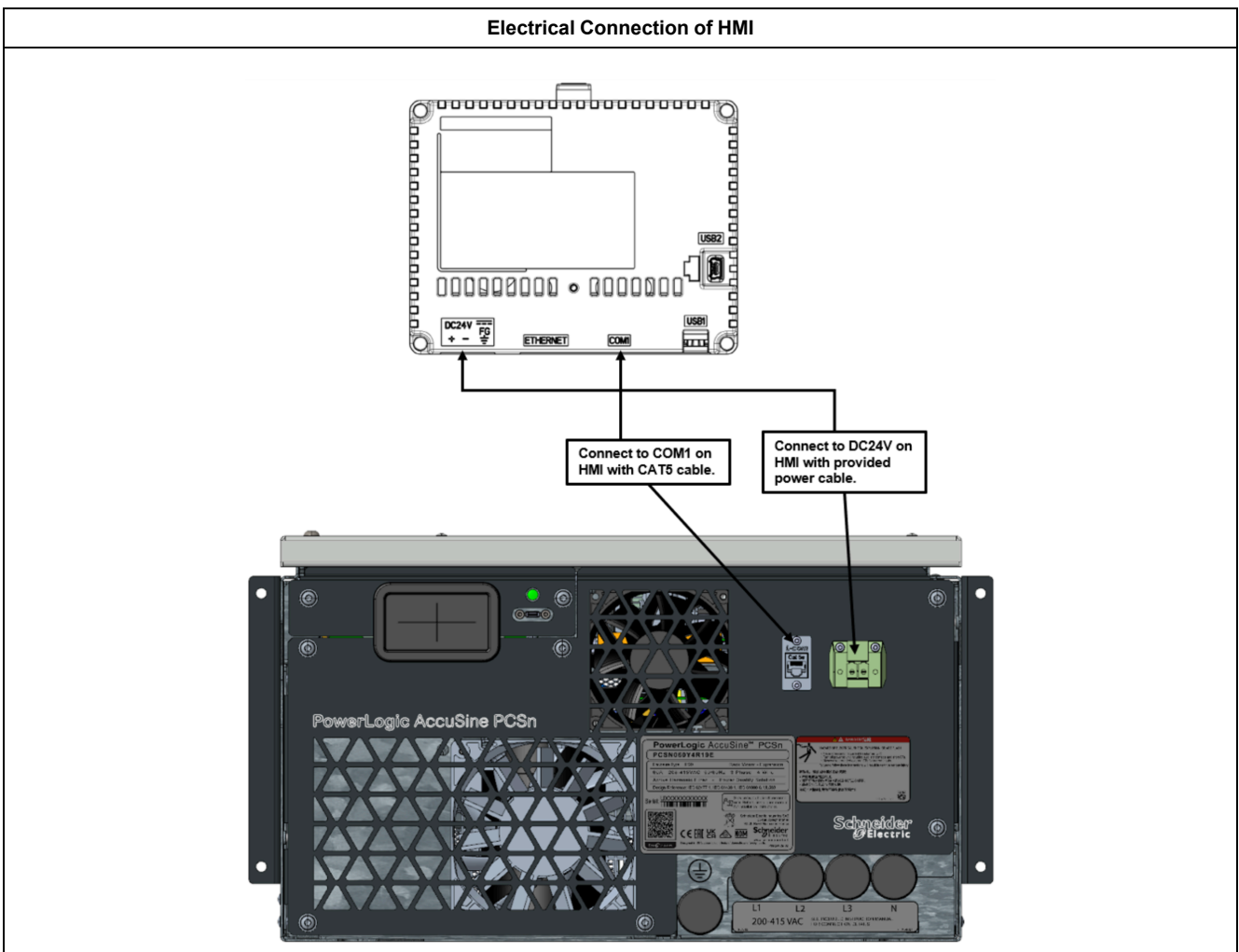

# Electrical Connection

## Line Voltage

Refer to Electrical Specification 20, 30, 50 and 60 A Units, page 43 to determine the line voltage that is compatible with the voltage range of the active filter.

## Over-current Protection Device Selection

Over-current protection is required for this product. The over-current protection required will be determined by the type of earthing system at the location and the amount of neutral current correction needed. For a detailed description on earthing systems, refer to Schneider Electric Cahier Technique no. 172, System earthings in LV. The available neutral current correction provided is user selected by either 100%, 200% or 300% of the unit rating.

It is recommended that the over-current protection device and associated unit have labels applied for identification purposes.

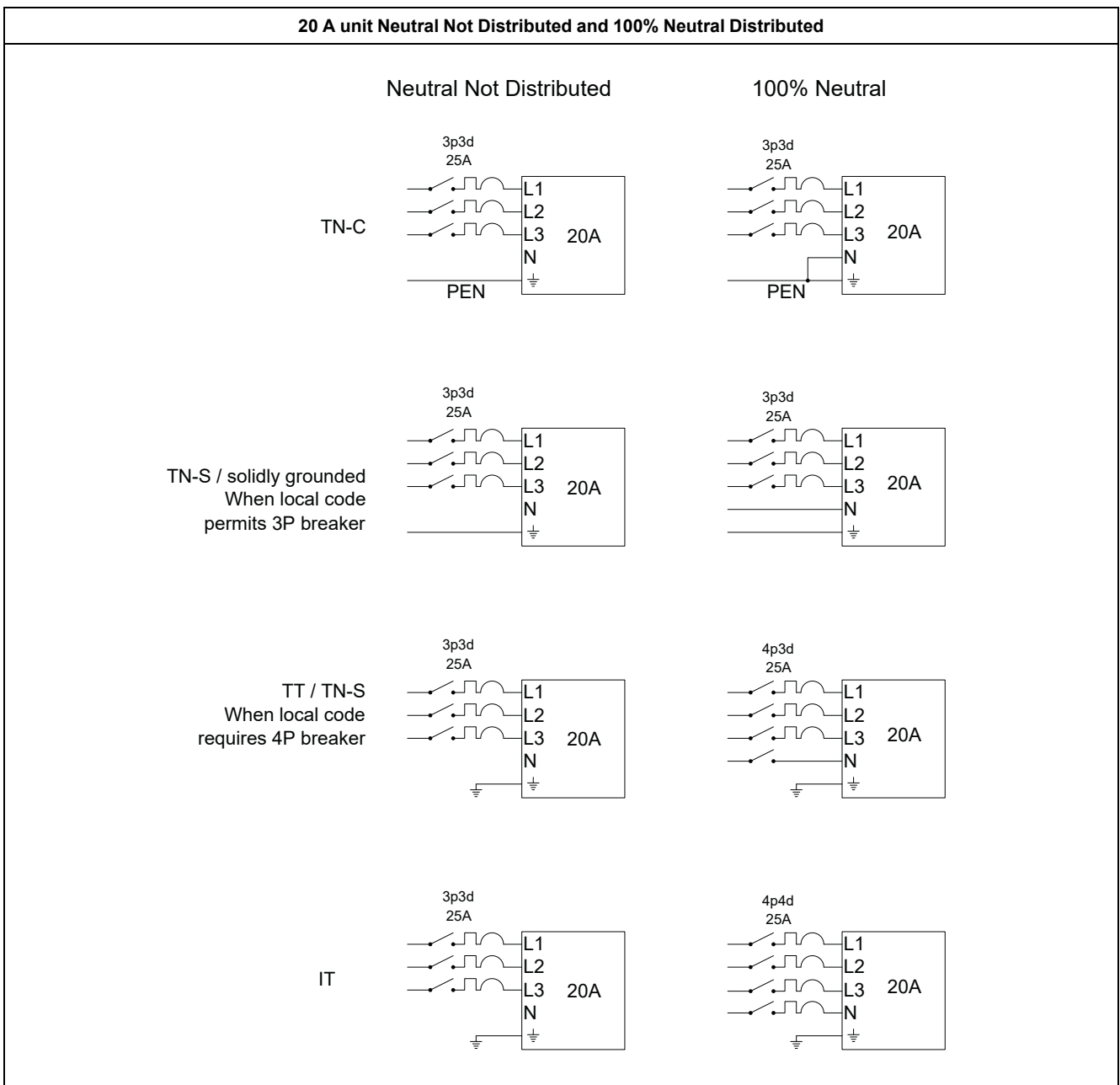

**20 A unit 200% Neutral Distributed and 300% Neutral Distributed**

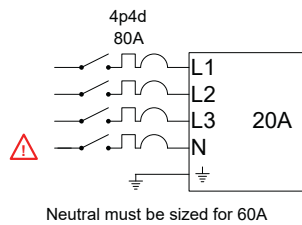
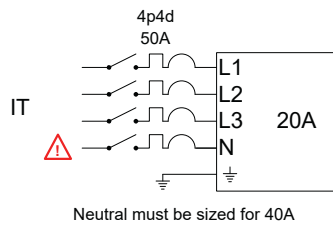
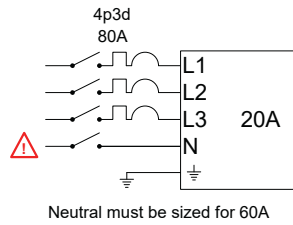
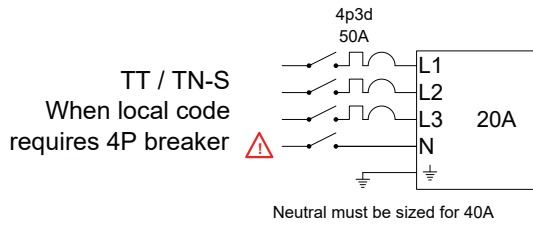
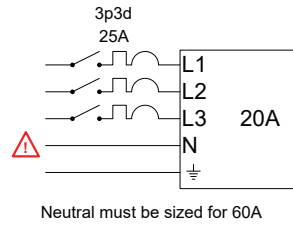
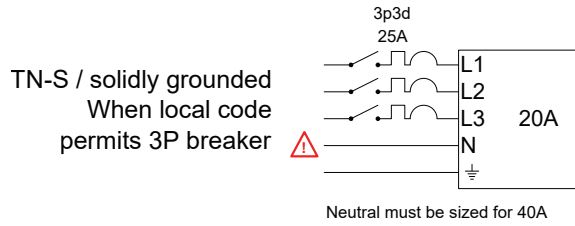
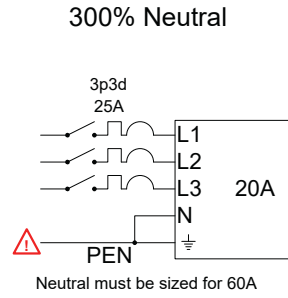
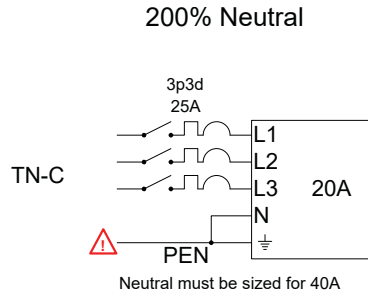

**30 A unit Neutral Not Distributed and 100% Neutral Distributed**

**Neutral Not Distributed**

**100% Neutral**

TN-C

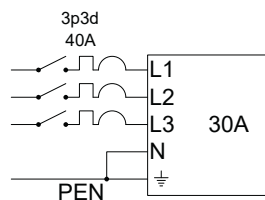
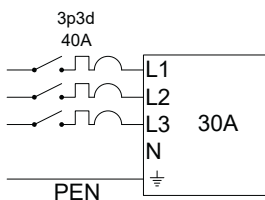

TN-S / solidly grounded  
When local code  
permits 3P breaker

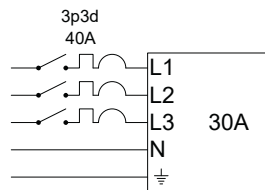
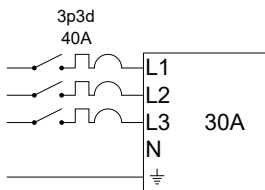

TT / TN-S  
When local code  
requires 4P breaker

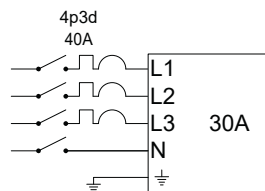
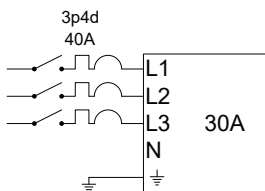

IT

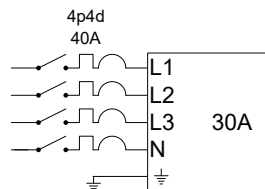
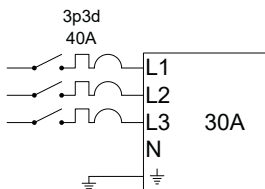

**30 A unit 200% Neutral Distributed and 300% Neutral Distributed**

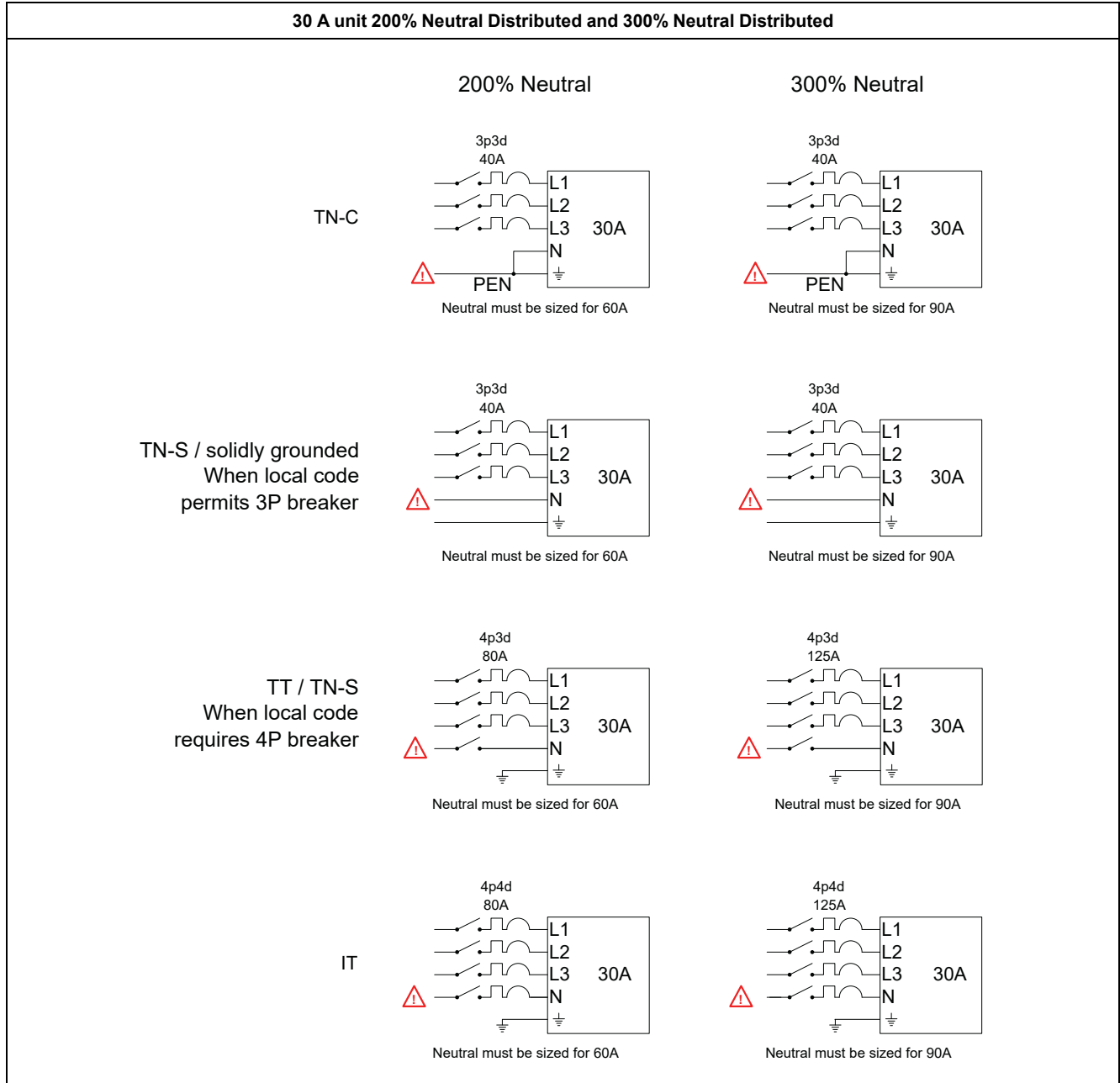

50 A unit Neutral Not Distributed and 100% Neutral Distributed

Neutral Not Distributed

100% Neutral

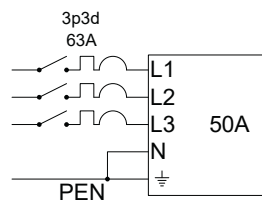
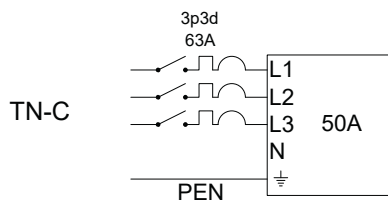

TN-S / solidly grounded  
When local code  
permits 3P breaker

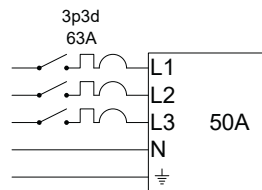
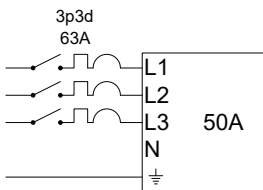

TT / TN-S  
When local code  
requires 4P breaker

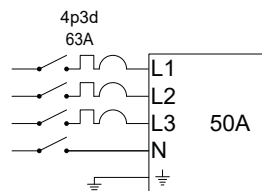
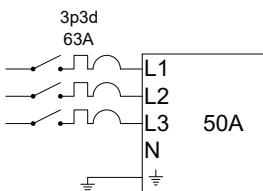

IT

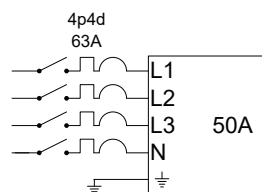
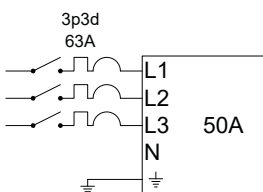

**50 A unit 200% Neutral Distributed and 300% Neutral Distributed**

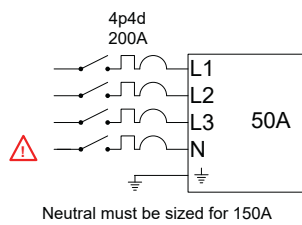
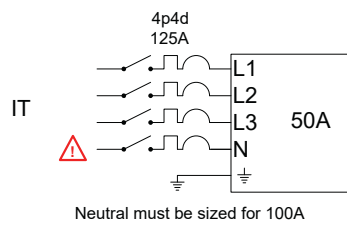
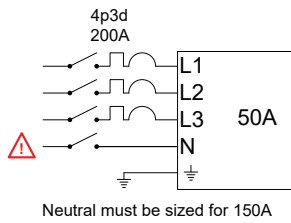
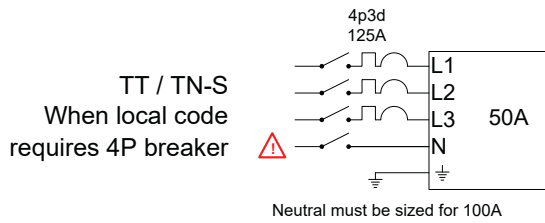
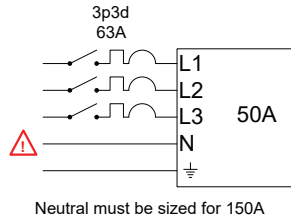
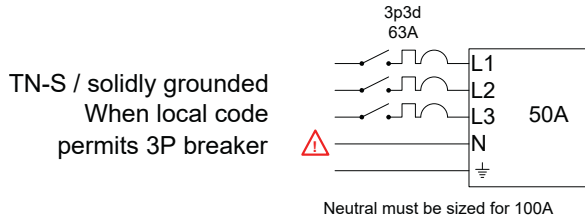
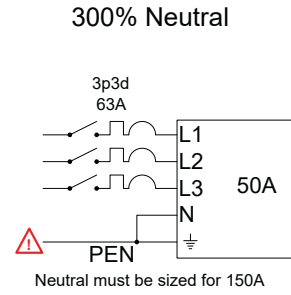
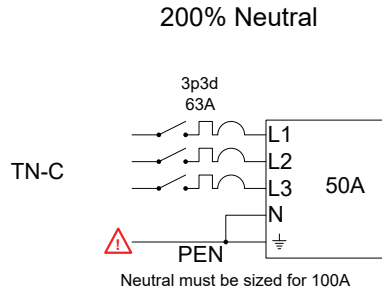

**60 A unit Neutral Not Distributed and 100% Neutral Distributed**

**Neutral Not Distributed**

**100% Neutral**

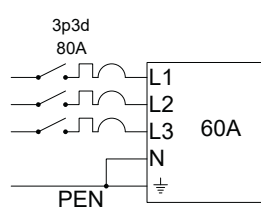
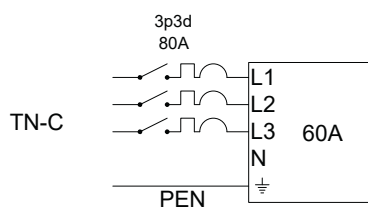

TN-S/solidly grounded  
When local code  
permits 3P breaker

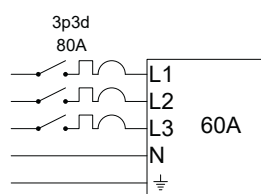
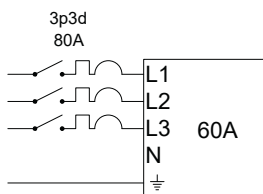

TT/TN-S  
When local code  
requires 4P breaker

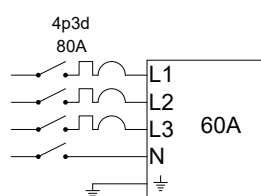
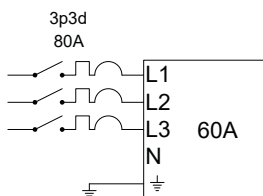

IT

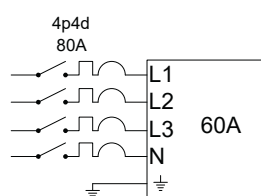
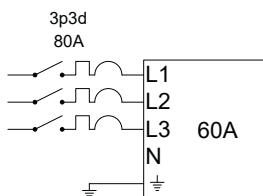

**60 A unit 200% Neutral Distributed and 300% Neutral Distributed**

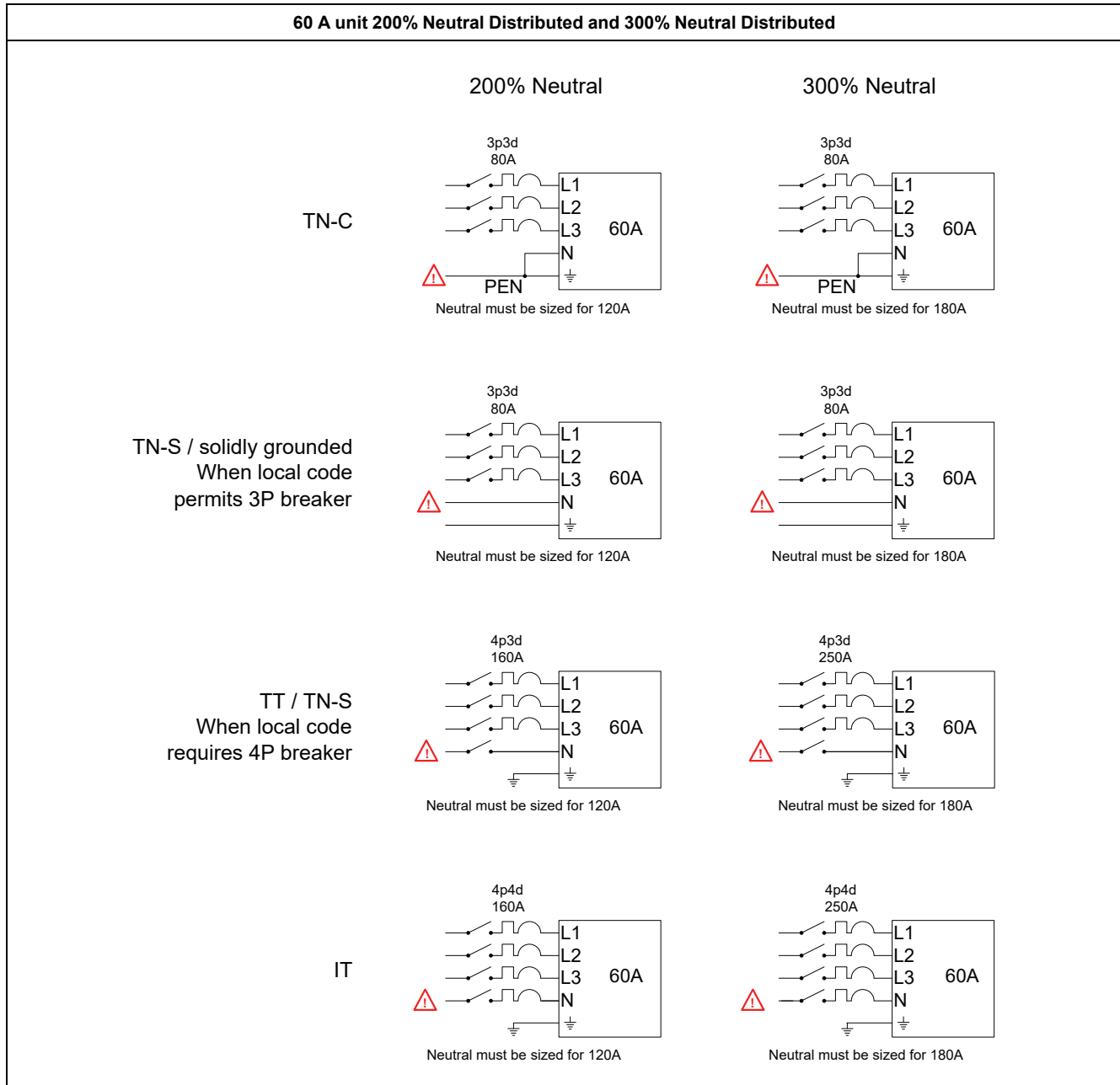

## Residual Current Device

Direct current can be introduced in the protective ground conductor of this PowerLogic™ AccuSine PCSn active filter. If a Residual Current Device (RCD/GFCI) or a Residual Current Monitor (RCM) is used for additional protection against direct or indirect contact, the following specific types must be used.

<b>⚠ WARNING</b>
<b>DIRECT CURRENT CAN BE INTRODUCED INTO THE PROTECTIVE GROUND CONDUCTOR</b>
Use a Type B Residual Current Device (RCD/GFCI) or a Residual Current Monitor (RCM) that has approval for use with frequency inverters and is sensitive to all types of current.
<b>Failure to follow these instructions can result in death, serious injury, or equipment damage.</b>

Conditions for use of a residual current device:

- The active filter has an increased leakage current at the moment power is applied. Use a Residual Current Device (RCD/GFCI) or a Residual Current Monitor (RCM) with a response delay.
- High-frequency currents must be filtered.

Choose a suitable model integrating:

- High frequency current filtering.
- A time delay that helps to prevent a triggering of the upstream device caused by the load from stray capacitance on power-on. The time delay is not available for 30 mA device; in this case, choose devices with immunity against nuisance triggering.

Due to high leakage current in standard operation, it is recommended to choose at least a 500 mA device. If the installation requires a residual current device less than 500 mA, it can be possible to use a device lower than 500 mA by changing the IT Grounding Relay parameter to Open (see User Manual PHA59669). If the installation includes several PowerLogic™ AccuSine PCSn active filters, provide one residual current device per unit.

## Power and Ground Cable Selection and Connections

**⚠️ ⚠️ DANGER**

**HAZARD OF ELECTRIC SHOCK, EXPLOSION, OR ARC FLASH**

- The unit must be properly grounded before power is applied.
- Ground equipment using the ground connecting point provided.

**Failure to follow these instructions will result in death or serious injury.**

All power cables must comply with all national and local electrical code. The outside diameter of the power and PE cables cannot exceed 19 mm. Installation of parallel power cabling is not supported.

Careful consideration must be given when sizing the neutral conductor, due to the majority of third harmonic which can lead to the current tripling in the neutral in relation to the phases.

When used as a harmonic current compensation device, the active filter produces currents at frequencies that are multiples of the AC line fundamental frequency. Power cables as well as input disconnect devices should be rated at 125% of the active filter rated current. This helps avoid excessive heating from any skin effect resistance increase at these higher frequencies.

**NOTE:** Check national and local codes and regulations to ensure compliance.

### Electrical Specification 20, 30, 50 and 60 A Units

PowerLogic™ AccuSine PCSn	Voltage Range (V)	Wire Temperature Ratings (°C)	Power and Ground Connection Type	Power and Ground Torque (Nm)
20...60 A	208...415	75, 90	M8 Stud	6

### IP42 Wall Mount Main and Expansion Electrical Connections

1. Open the door of IP42, use T20 screwdriver to remove the 5XM4 screws directly below and remove the Lower Cover.

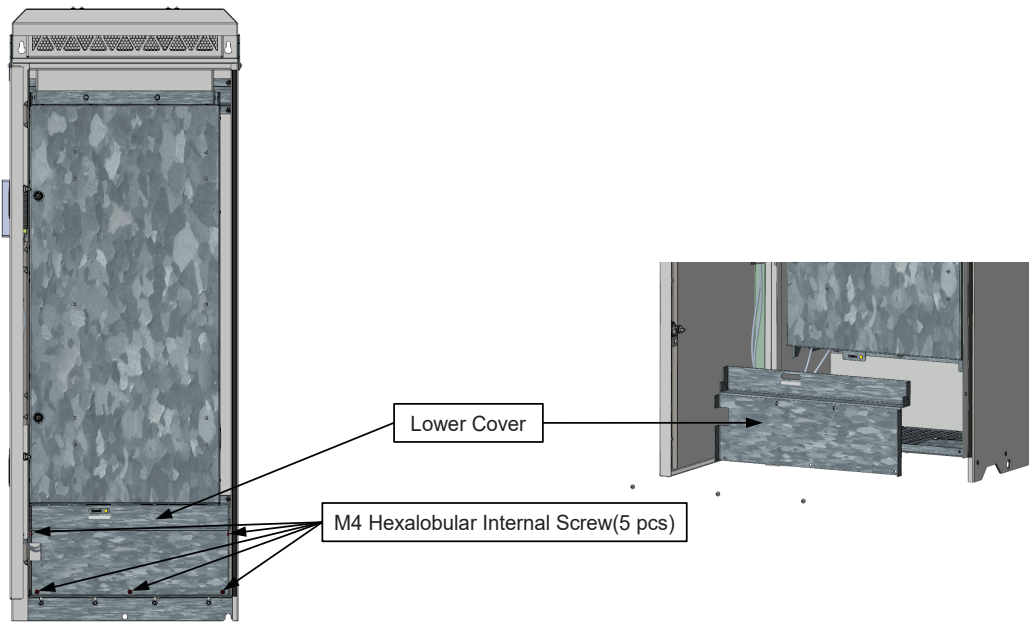

2. Use T20 screwdriver to remove the 4XM4 screws directly below and remove the Gland Plate.

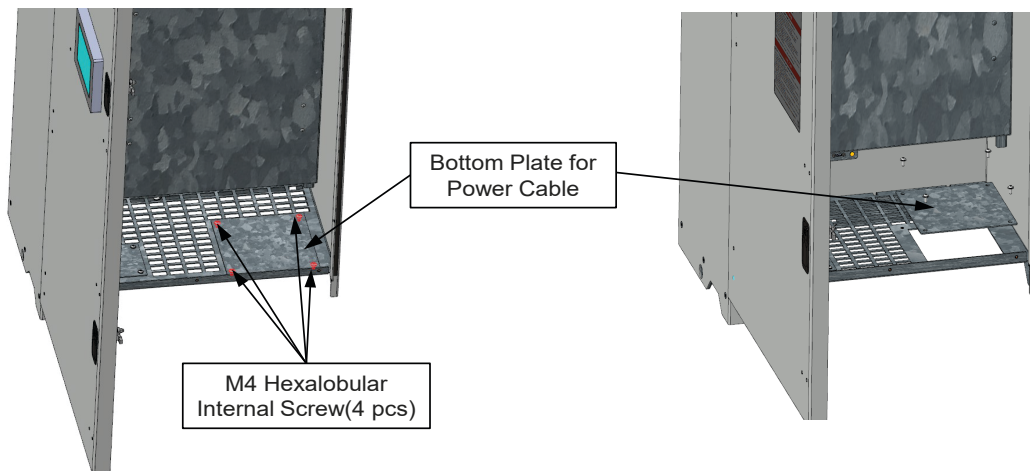

3. Use T20/T25 screwdriver to remove the 2XM5 screws directly below and remove the Line-in Shroud.

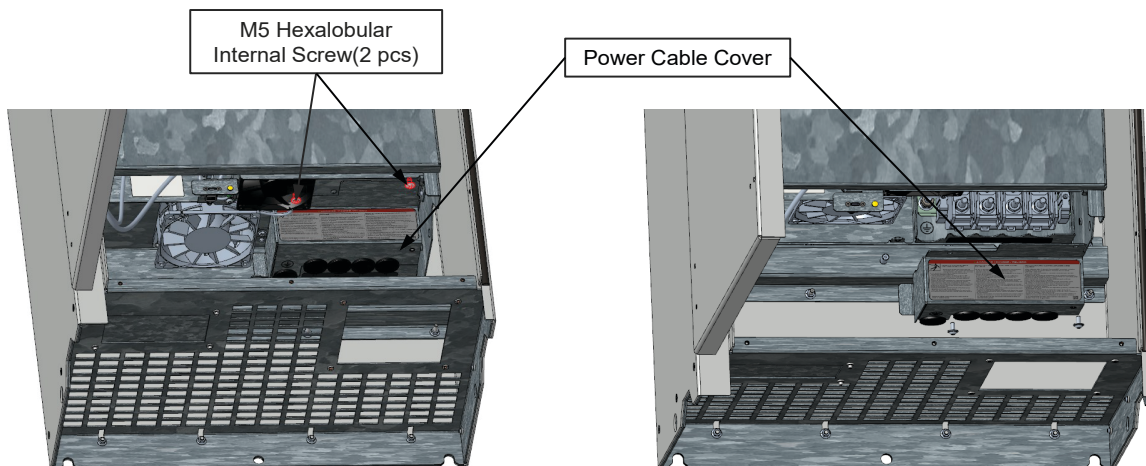

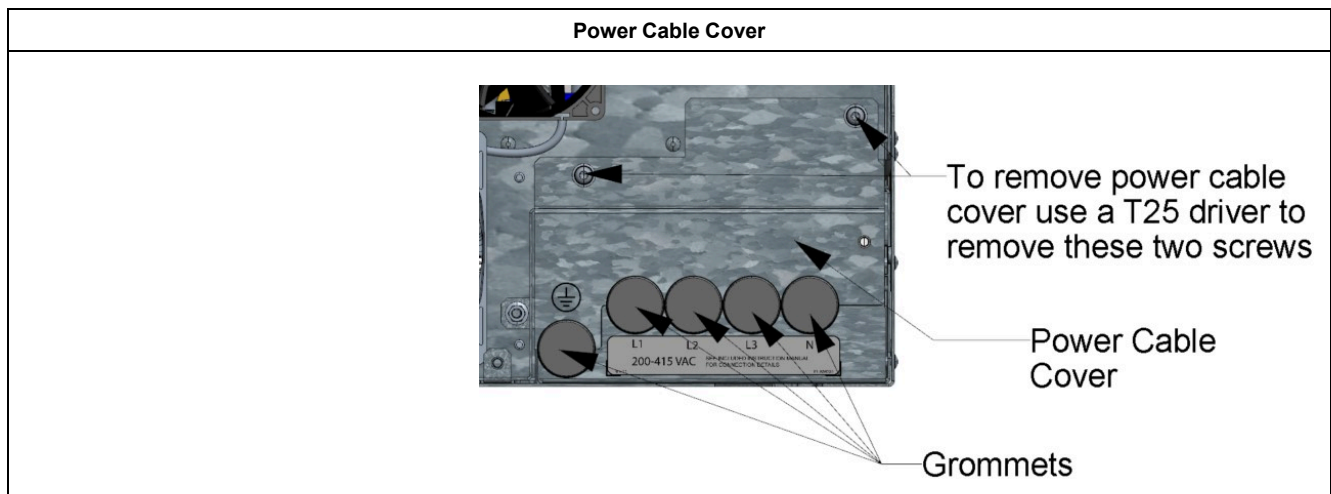

Remove the grommets from the power cable cover.

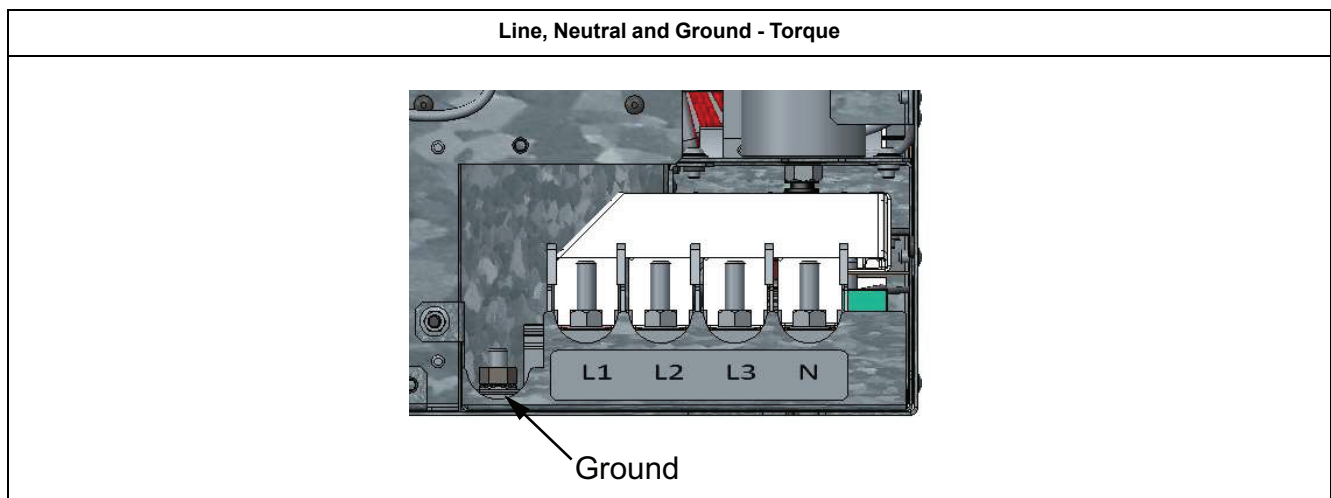

Using a punch or similar, create a hole in the grommet just large enough to allow the line, ground and neutral (if required) wires to pass through the grommet.

Pass one cable through each of the grommets.

Connect an appropriate one-hole crimp lug on the end of each wire for an 8 mm stud.

Reinstall the power cable cover using the T25 hardware. Make sure that the grommets are properly seated.

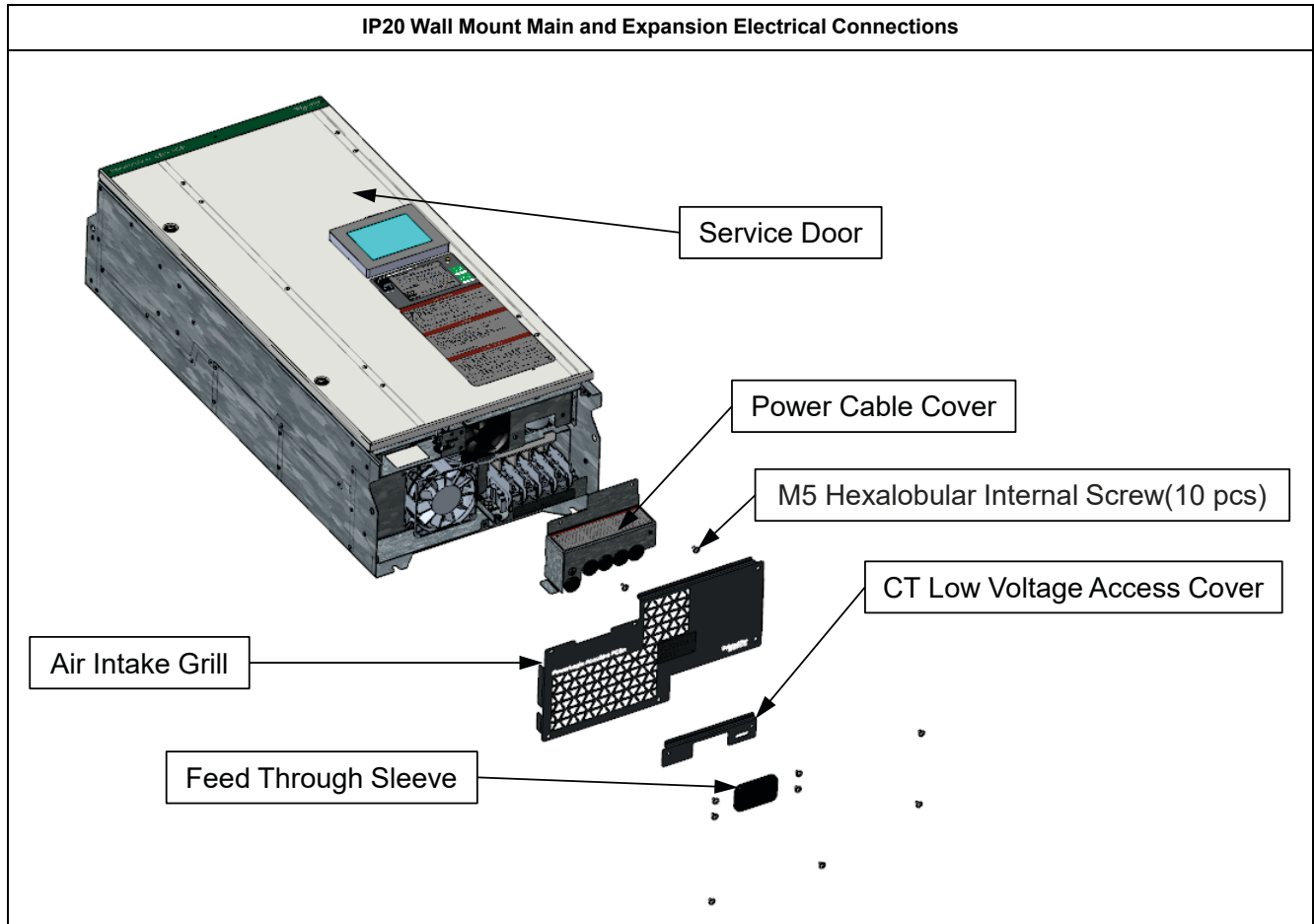

Using a T30 driver open the service door.

At the bottom of the unit using a T25 driver remove the air intake grill and power cable cover.

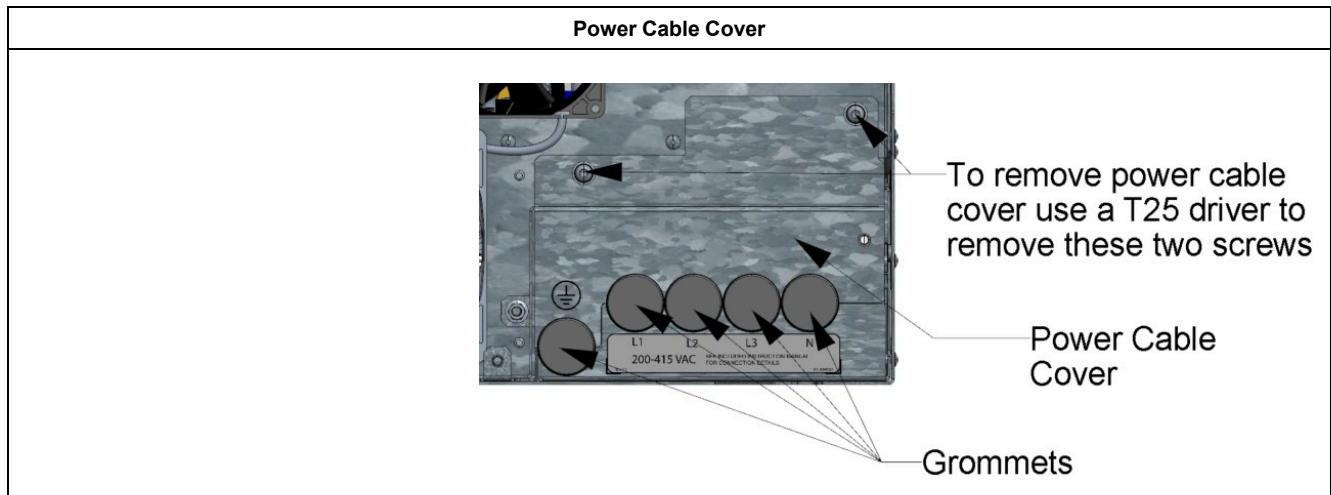

Remove the grommets from the power cable cover.

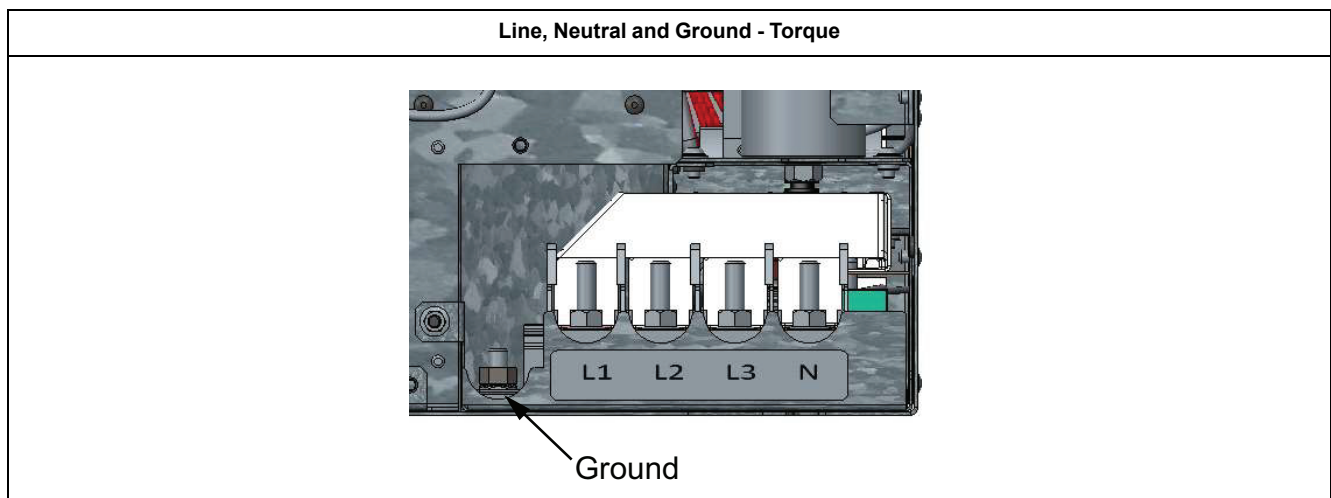

Using a punch or similar, create a hole in the grommet just large enough to allow the line, ground and neutral (if required) wires to pass through the grommet.

Pass one cable through each of the grommets.

Connect an appropriate one-hole crimp lug on the end of each wire for an 8 mm stud.

Reinstall the power cable cover using the T25 hardware. Make sure that the grommets are properly seated.

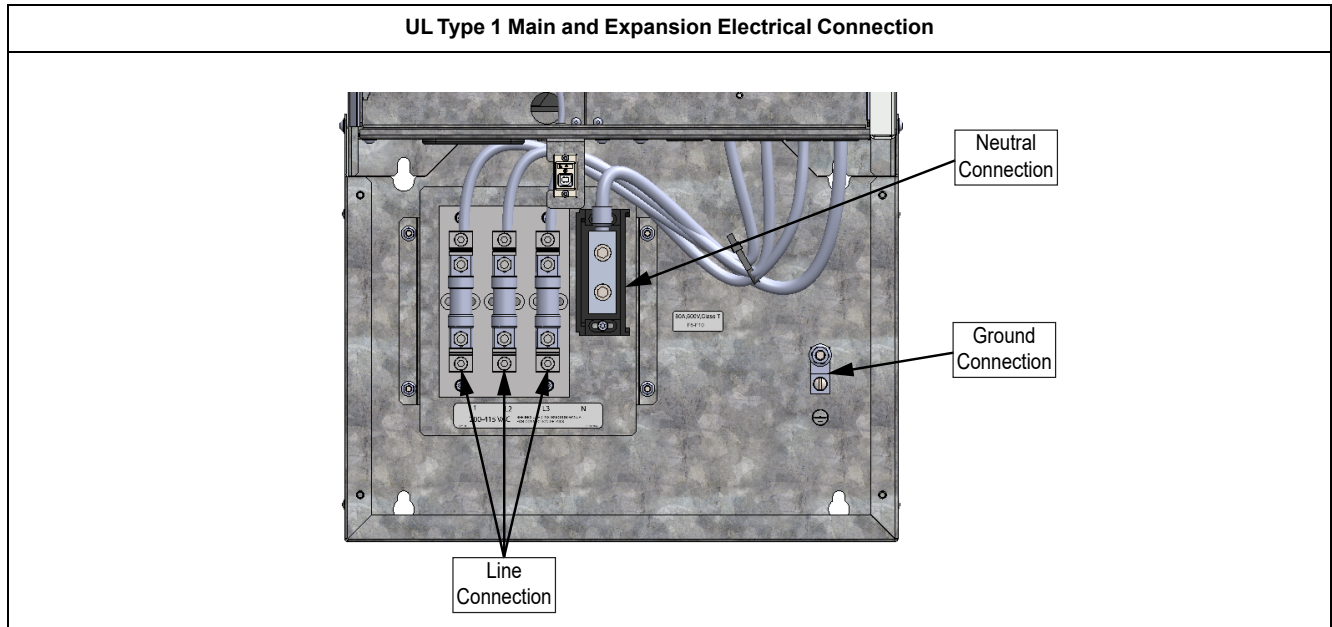

Remove the bottom air intake grill. Connect power and neutral conductors, connect ground wire to the provided ground lug.

**Wire Sizing and Terminal Torque Specifications for UL Type 1 Models**

Unit Rating	Phase Lug			Neutral Lug			Ground Lug		
	Minimum	Maximum	Torque	Minimum	Maximum	Torque	Minimum	Maximum	Torque
20 A and 30 A	14 AWG	6 AWG	2.8 Nm	14 AWG	1/0 AWG	13.6 Nm	14 AWG	6 AWG	2.8 Nm
							4 AWG	2 AWG	5.6 Nm
50 A and 60 A	6 AWG	2 AWG	4.5 Nm	6 AWG	2/0 AWG	42.4 Nm	14 AWG	6 AWG	2.8 Nm
							4 AWG	2 AWG	5.6 nm



## Removing CT Low Voltage Cover, Air Intake Grill and Power Cable Cover

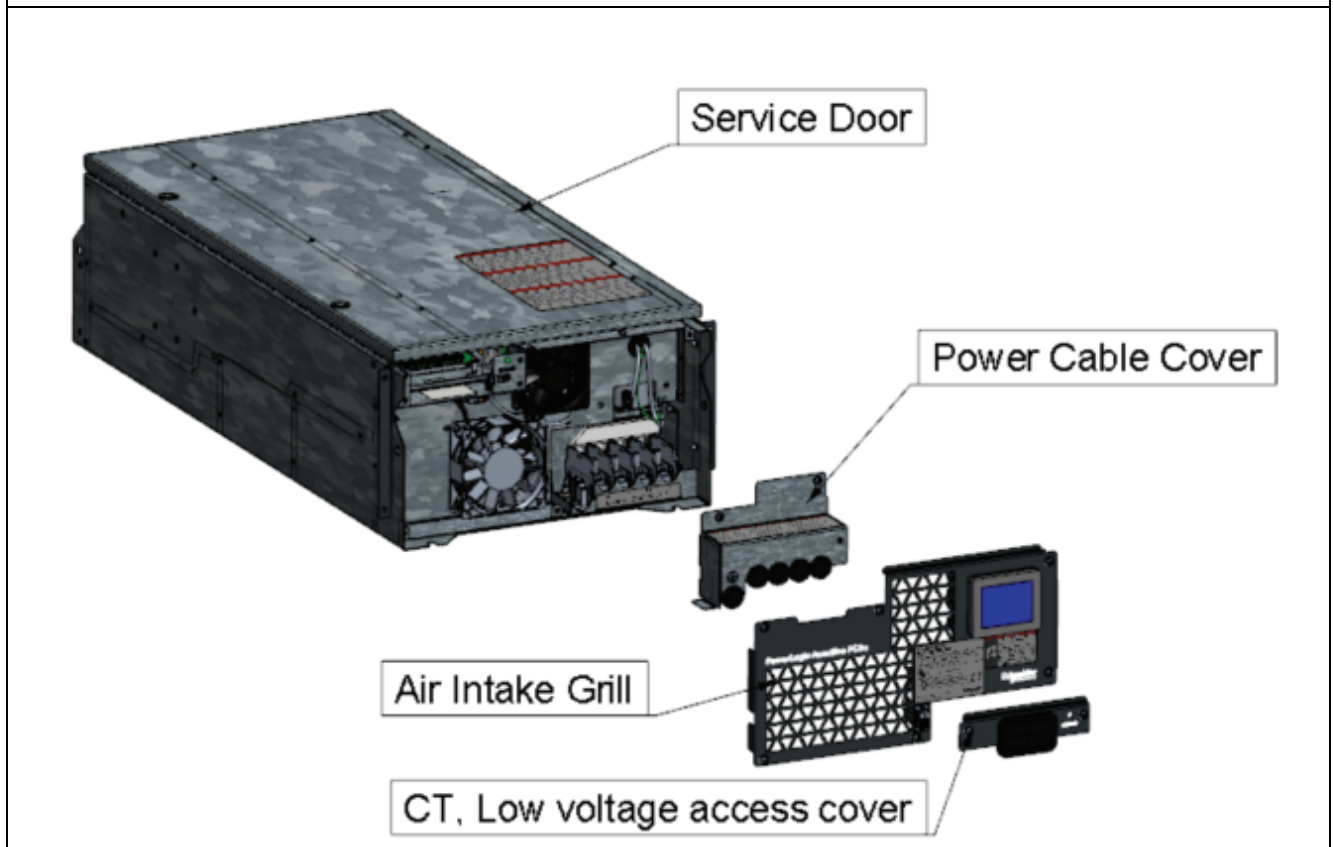

Use a T25 driver to remove the CT Low voltage cover, air intake grill and power cable cover.

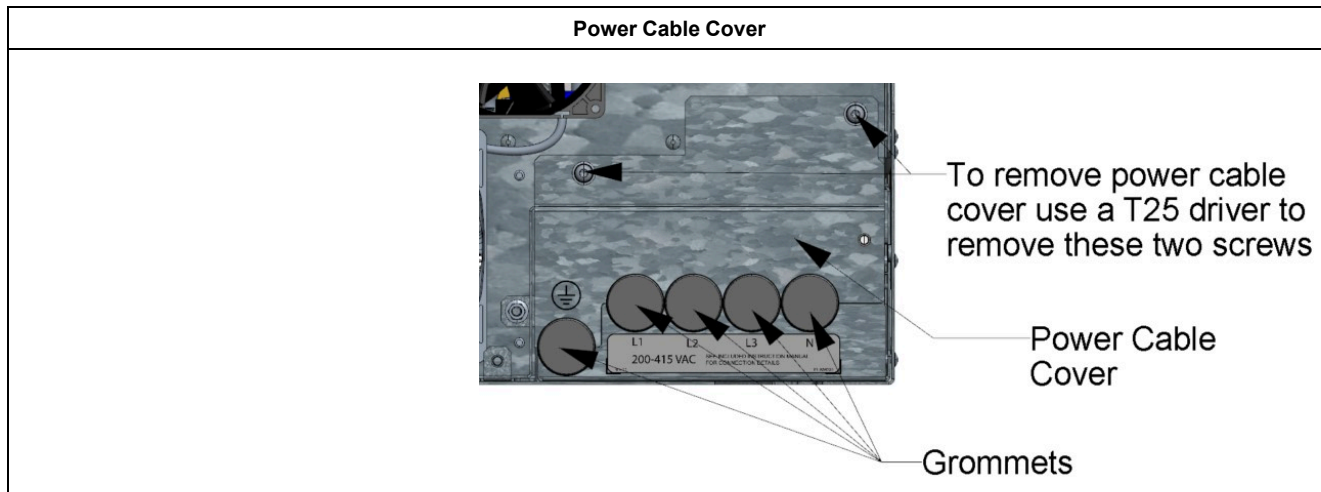

Remove the grommets from the power cable cover.

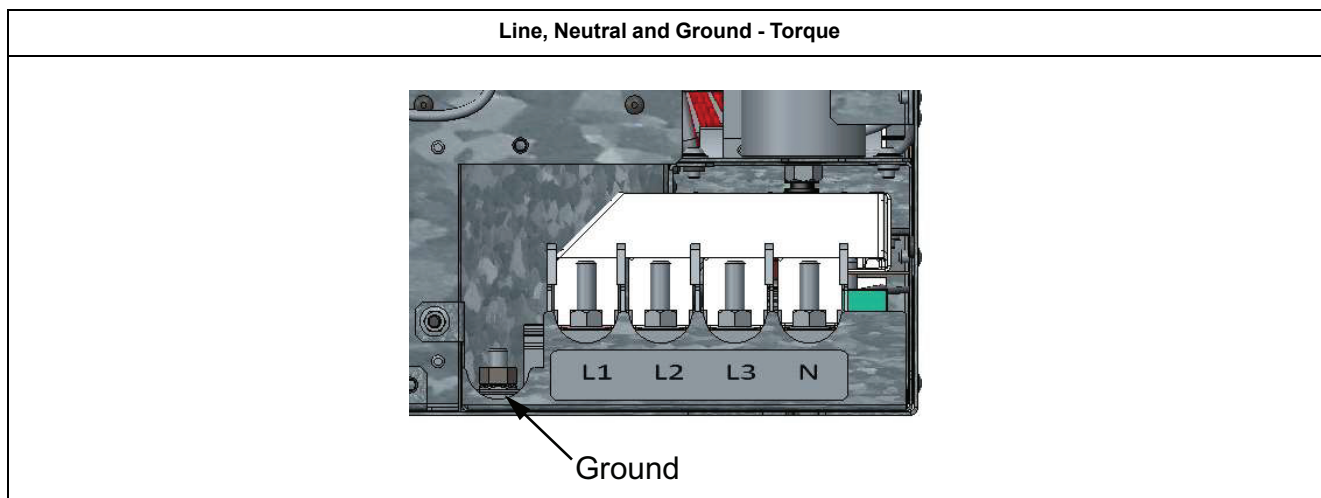

Using a punch or similar, create a hole in the grommet just large enough to allow the line, ground and neutral (if required) wires to pass through the grommet.

Pass one cable through each of the grommets.

Connect an appropriate one-hole crimp lug on the end of each wire for an 8 mm stud.

Reinstall the power cable cover using the T25 hardware. Make sure that the grommets are properly seated.

**NOTE:** Line, neutral and ground studs are 8 mm. The nuts require a 13 mm socket. Torque the line, ground and neutral nuts to 6 Nm.

## Current Transformers

### **⚡ ⚠ DANGER**

#### **HAZARD OF ELECTRIC SHOCK, EXPLOSION, OR ARC FLASH**

- Never open circuit a current transformer.
- Always use grounded external CTs for current inputs.

**Failure to follow these instructions will result in death or serious injury.**

Make sure that CT secondary current is not present when wiring the CT secondary connections. The shorting jumpers must be installed at the X1 to X2 OUT of each CT channel on the CT board unless you are connecting an additional primary parallel unit. Refer to Source Side CT position Single Main with Neutral Connected.

## General CT Information

The CT must be orientated properly during installation. The orientation is specified in the drawings with an arrow indicating the direction or polarity of the CT. Most CT manufacturers will indicate orientation with a label indicating H1 on one side of the CT or a dot. There can also be a label indicating H2 and/or an arrow on the CT. The H1 side of the CT should always be closest to the power source. If the CT has an orientation arrow, it should point from the source towards the load. See the installation instructions for the specific CTs being installed.

A shorting terminal block or shorting switch with galvanic isolation to the active filter for the CT secondary is required. Insert an interposing terminal block in a separate enclosure with the ability to short the secondary wiring of the CT. This provides the ability to short the CT without entering the active filter enclosure (which otherwise would require a power shutdown). Shorting terminal blocks are available in the catalog.

CT location is defined in relationship to the active filter system. CT location on the Source Side indicates that the CTs are physically located upstream of the active filter. The CTs will measure the improvement to the current as a result of the active filter operating. A CT location on the Load Side indicates that the CTs are downstream of the active filter. The CTs will monitor the Load current provided by both the source and active filter currents.

Each main unit, which is equipped with a HMI, can have CTs connected. Expansion units do not have a CT connection. Only two CTs are required if a neutral conductor is not connected to the AccuSine PCSn system and there are no line-to-neutral connected loads. If a neutral conductor is connected and/or there are line-to-neutral connected loads, three CTs are required. When two CTs are installed, one on L1 phase and one on L2 phase of the conductors powering the loads to be compensated by the active filter system. In applications where a CT cannot be installed on L2 conductor, installing on L1 and L3 is permitted but the commissioning person should be made aware of the CT installation prior to commissioning the unit.

### **NOTICE**

#### **MEASUREMENT ERRORS**

CTs must be physically separated from any perpendicular conductor by at least 25 mm (1 in) for every 1000 A of current flowing through the perpendicular conductor.

**Failure to follow this instruction can result in a reduction in performance of the active filter.**

If this practice is not followed, the magnetic field produced by the current flowing on the perpendicular conductor will cause CT measurement errors.

## Minimum CT Requirements

The active filter uses a minimum of two external current transformers (CTs) to measure load current waveforms. Standard CTs rated for 50/60 Hz or 400 Hz with Type 1 accuracy rating, with a 5 A or 1 A secondary are acceptable. The largest primary rating for the CT is 10,000 A. Any splicing to the CT leads needs to be done with crimp style connectors or soldered.

The CT should be mounted on phases L1 and L2 with the orientation arrow pointing toward the load. Systems that are using two CTs can have the CTs installed on L1 and L3 or L2 and L3 if necessary. If L1 and L3 or, L2 and L3 CT configurations are used, this information must be provided to the qualified person commissioning the unit. Three external CTs are required if line-to-neutral connected loads are present.

**NOTICE****REDUCED PERFORMANCE**

CT wiring must be routed separately from power cables.

**Failure to follow this instruction can result in a reduction in performance.**

CT wiring must be routed directly from the conduit entry-plate to the terminal block of the CT board.

CT must be selected for:

- 5 A or 1 A secondary
- 100 to 10,000 primary rating
- 50/60 Hz or 400 Hz Rated
- Type 1 accuracy
- The CT primary current rating must exceed the maximum load current where they are installed;
- The maximum burden (in VA) on the CT is formed by the CT wiring and total active filter burden. This is equal to 1.0 VA for CTs with a 5 A secondary rating or 0.04 VA for CTs with a 1 A secondary rating.
- Maximum wire size of the CT secondary is 2.5 mm<sup>2</sup> (14 AWG). Consult the CT manufacturer for secondary wiring recommendations. See 5 A Secondary Maximum Wire Length with 2.5 mm<sup>2</sup> (14 AWG) Diameter Wire and 1 A Secondary Maximum Wire Length with 2.5 mm<sup>2</sup> (14 AWG) Diameter Wire for adding wire to CT secondary wiring.

## Maximum Wire Length

### 5 A Secondary Maximum Wire Length

Maximum wire length from active filter to CT in meters		
CTs burden capacity with 5 A secondary rating	1.5 mm <sup>2</sup>	2.5 mm <sup>2</sup>
5 VA	15	24
15 VA	51	84
25 VA	87	143
30VA	105	173
35 VA	124	203
45 VA	160	263

Maximum wire length from active filter to CT in feet		
CTs burden capacity with 5 A secondary rating	14 AWG	12 AWG
5 VA	65	103
15 VA	228	361
25 VA	390	619
30VA	472	748
35 VA	553	877
45 VA	715	1135

### 1 A Secondary Maximum Wire Length

Maximum wire length from active filter to CT in meters		
CTs burden capacity with 1 A secondary rating	1.5 mm <sup>2</sup>	2.5 mm <sup>2</sup>
5 VA	451	740
15 VA	1360	2233
25 VA	2269	3725
30VA	2724	4472
35 VA	3178	5218
45 VA	4087	6710

Maximum wire length from active filter to CT in feet		
CTs burden capacity with 1 A secondary rating	14 AWG	12 AWG
5 VA	2016	3200
15 VA	6081	9652
25 VA	10146	16103
30VA	12179	19329
35 VA	14211	22555
45 VA	18276	29006

CT secondary wiring must be either twisted and/or shielded pairs.

It is not recommended to connect the active filter CTs to any other loads. Use a separate current transformer if additional uses are required.

Any splicing to the CT leads needs to be done with crimp style connectors or soldered.

X2 of each CT installed must be grounded as close to the CT as possible.

A single active filter, not operating in parallel, can have the CTs installed either on the source side or load side of the active filter. Parallel systems must have the main CTs installed on the source side of the active filter system.

### CT to CT Board Connection

The CT connection is made at the CT board. Refer to [Control Board and CT Board Details](#). The CT plug can be removed by using a small flat tipped screwdriver. If the CT plug is removed, make sure to secure it back using a flat tipped screwdriver.

Typically, L1 CT will be connected to CH1 IN. There are two X1 and X2 IN terminals. Use the second set of IN terminals to connect additional CTs that can be required for site specific conditions. X1 and X2 OUT are used for parallel active filter systems.

The terminal block on the CT board can accept wire sizes of up to 2.5 mm<sup>2</sup> (14 AWG) wire and has a torque specification of 0.6 Nm (5.3 lb-in).

**⚠️ DANGER**

**HAZARD OF ELECTRIC SHOCK, EXPLOSION, OR ARC FLASH**

Ensure that the CT plug and all the CT connections are tight prior to energizing the system.

**Failure to follow these instructions will result in death or serious injury.**

## NOTICE

### CIRCULATING CURRENTS

When using shielded CT secondary wire, only ground the shield at one end of the cable.

**Failure to follow this instruction can result in a reduction in performance.**

## NOTICE

### INACCURATE FILTER OPERATION

Do not allow the conductor on which the CT is mounted to become lodged in the joint area of a split-core CT.

**Failure to follow this instruction can result in inaccurate filter operation.**

Control Board and CT Board Details

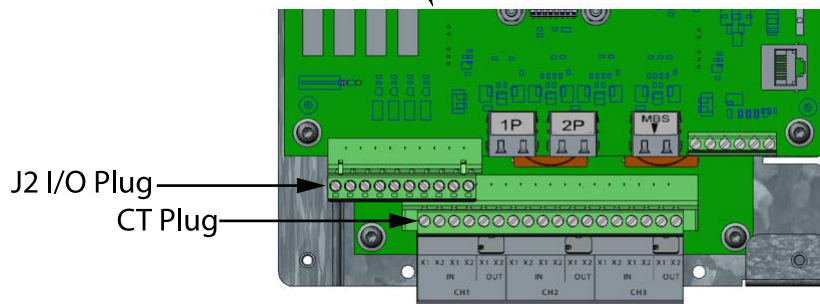
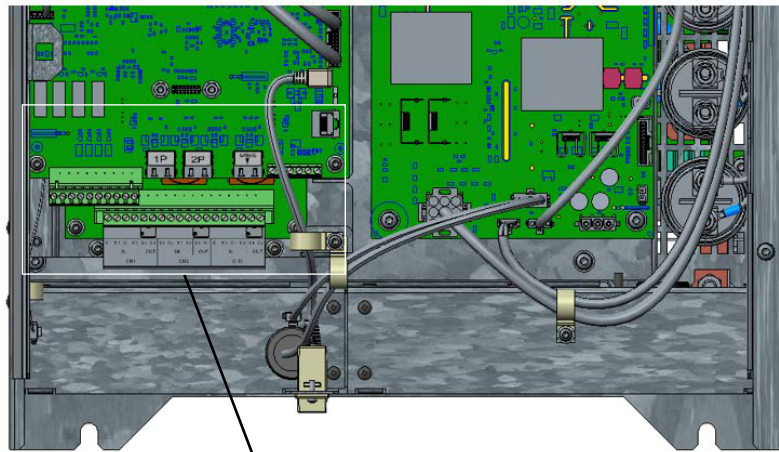

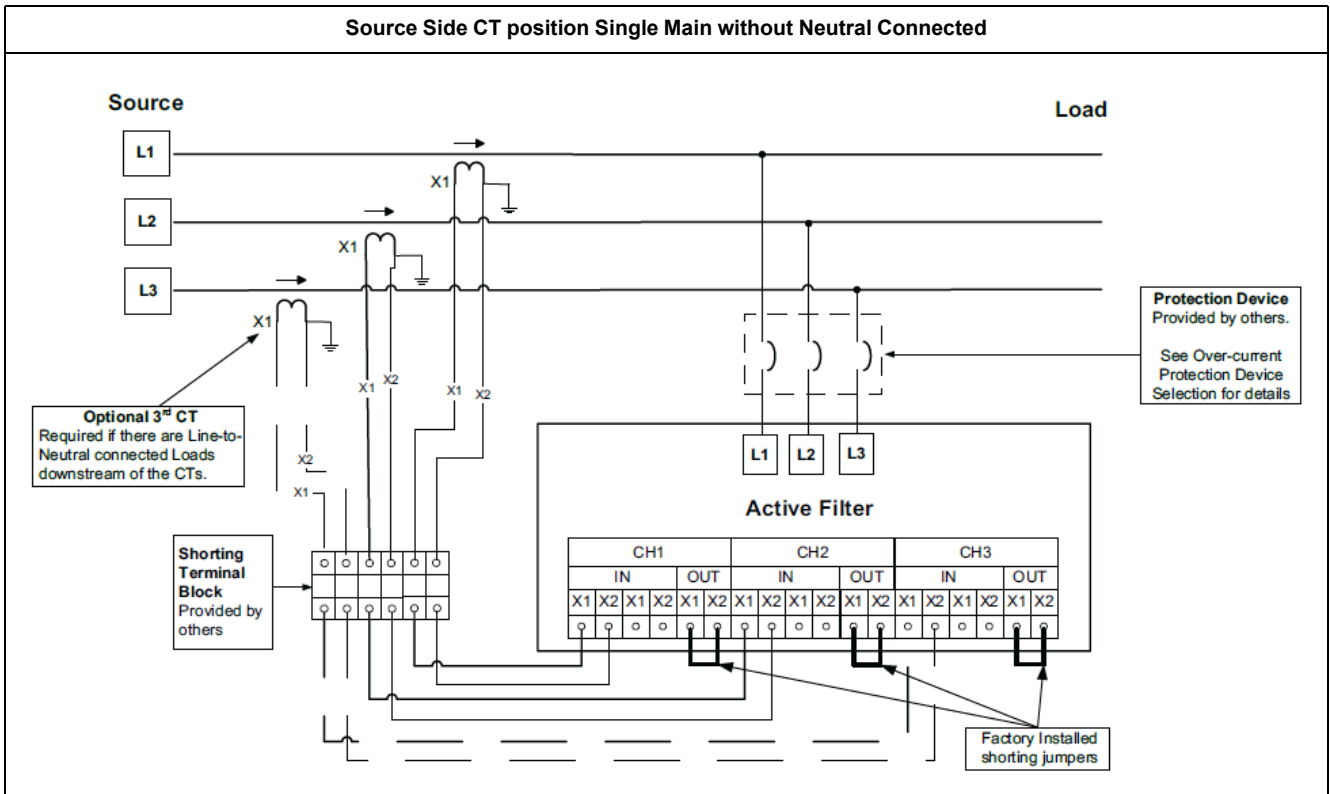
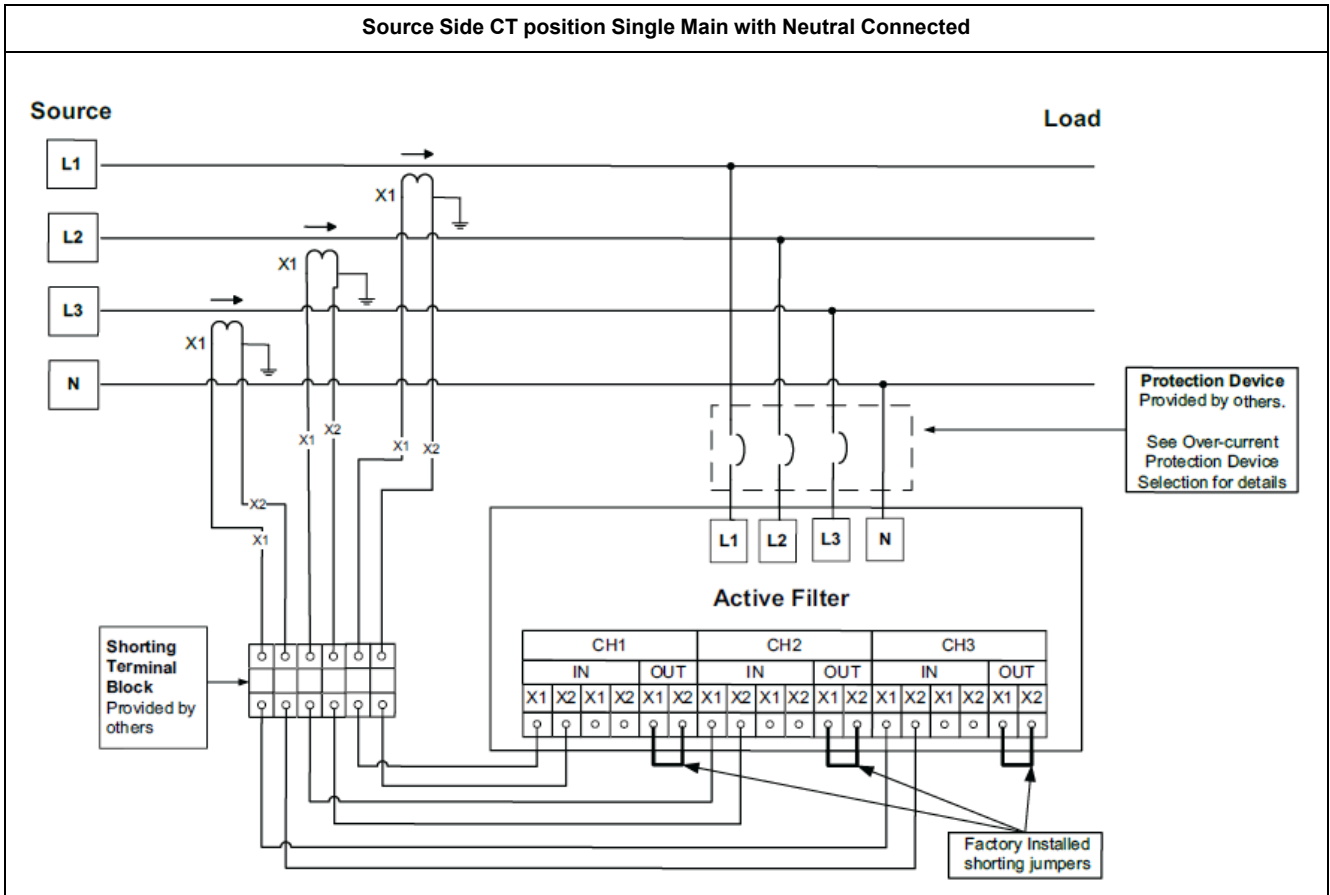

**NOTE:** The factory installed shunting jumpers must be installed.

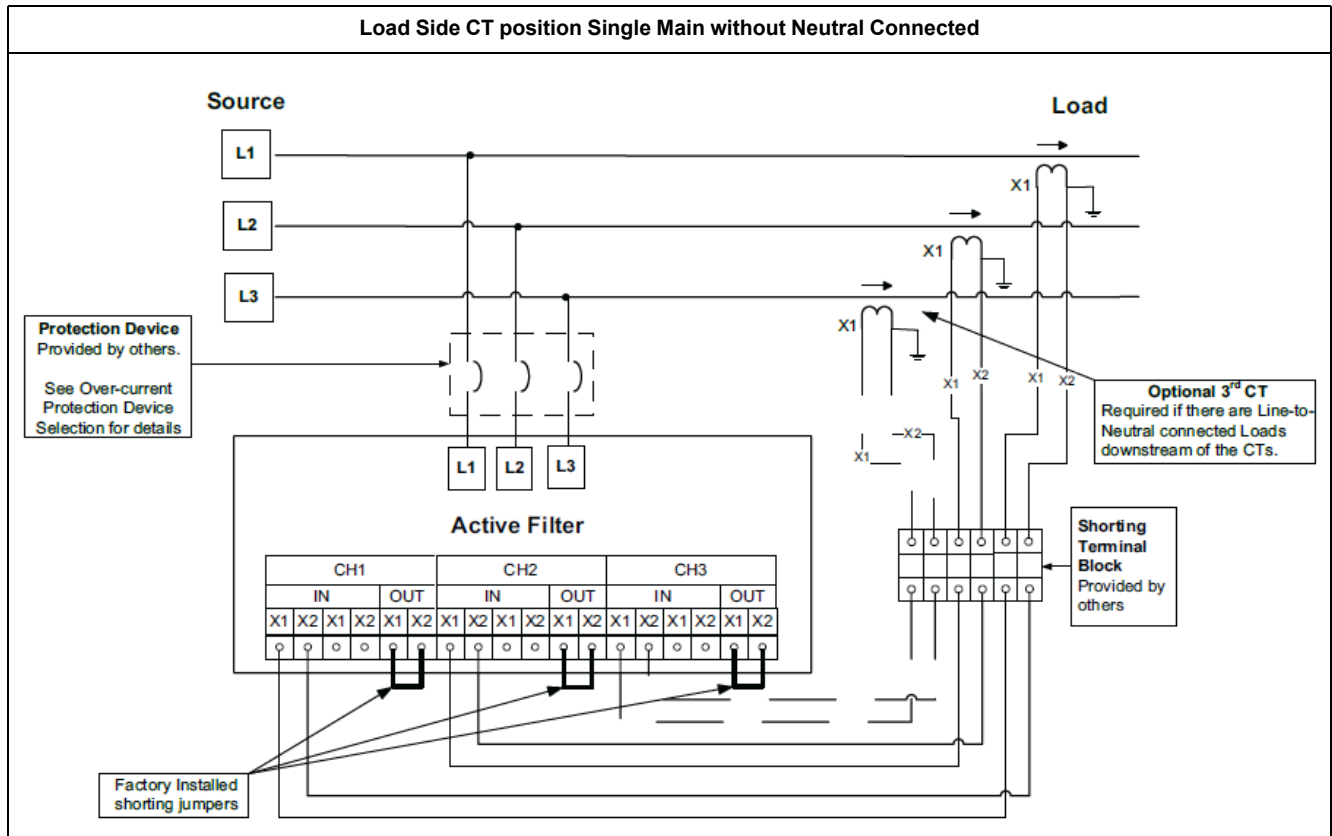
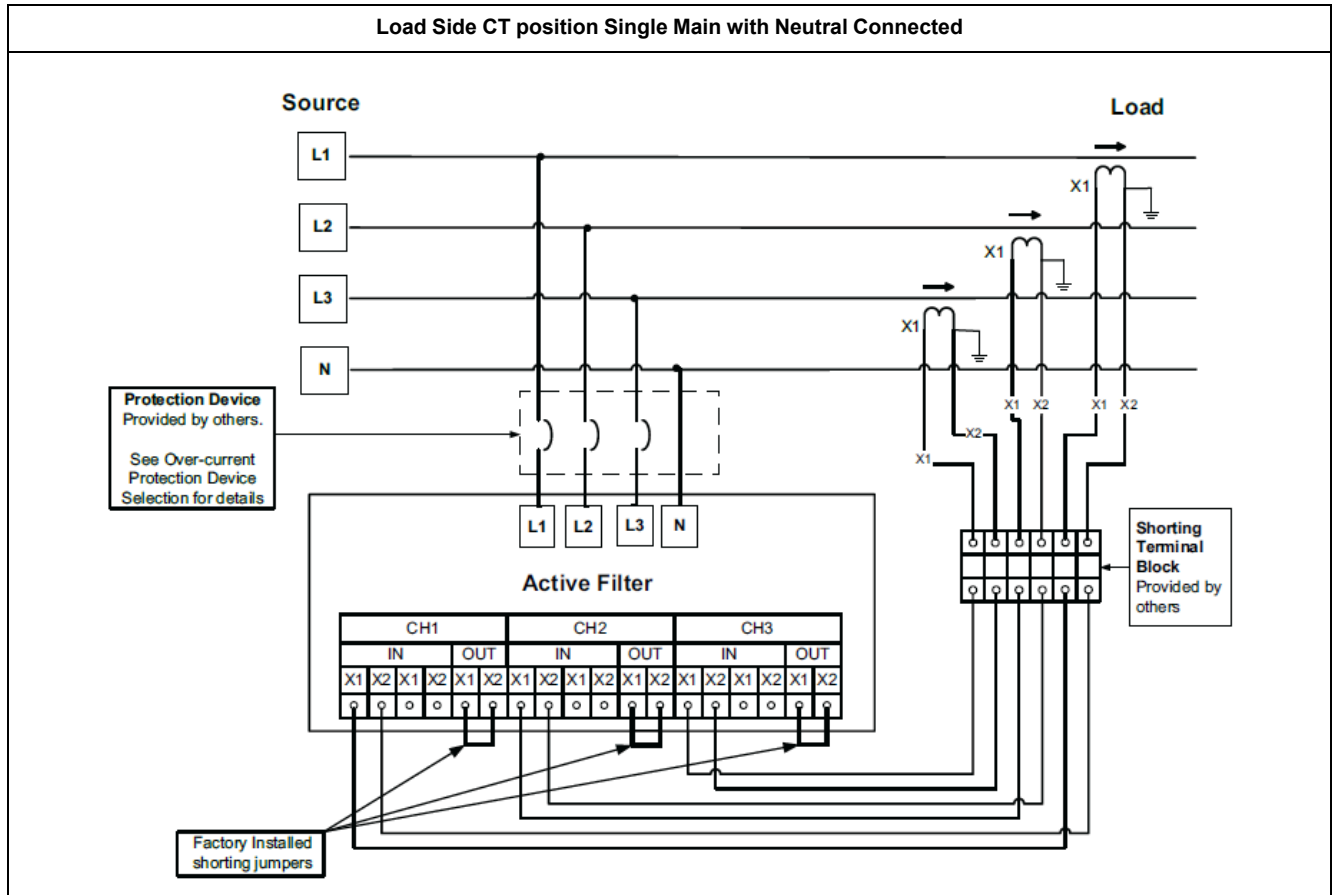

**NOTE:** The factory installed shorting jumpers must be installed.

## Parallel System

Up to 12 active filters can be installed in parallel. If more than 12 units in parallel are required, contact the local sales representative for assistance prior to installation.

## CT Installation Parallel Units

### **DANGER**

#### **HAZARD OF ELECTRIC SHOCK, EXPLOSION, OR ARC FLASH**

The factory provided shorting jumpers must be installed at the OUT of the CT board of the last unit with CT secondary wiring connected.

**Failure to follow these instructions will result in death or serious injury.**

You can set up the active filters to primary or secondary. To be a candidate as a primary, the unit must be provided with CT secondary wiring to the CT board. See [Control Board and CT Board Details](#). There is no limit to the number of units that can be set up as a primary candidate. At least two units must be capable of being the primary in any parallel installation for redundancy.

The main CTs must be installed on the source side of the parallel active filter system. Examples of CT secondary wiring can be seen on the following pages in this section. Refer to [Over-current Protection Device Selection](#), page 35 for information on circuit breaker and fuses required.

Two Main Units with Neutral Connected

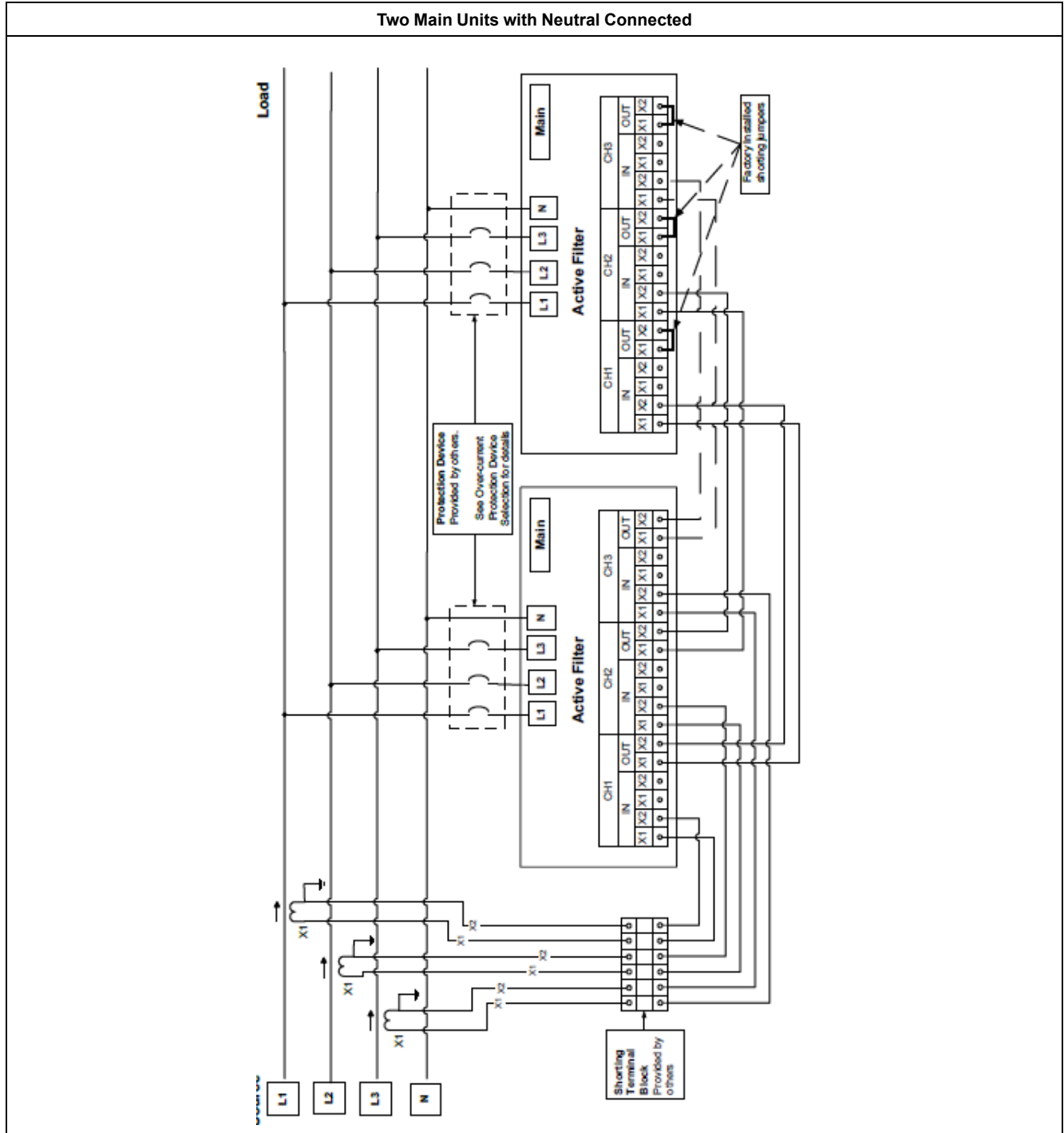

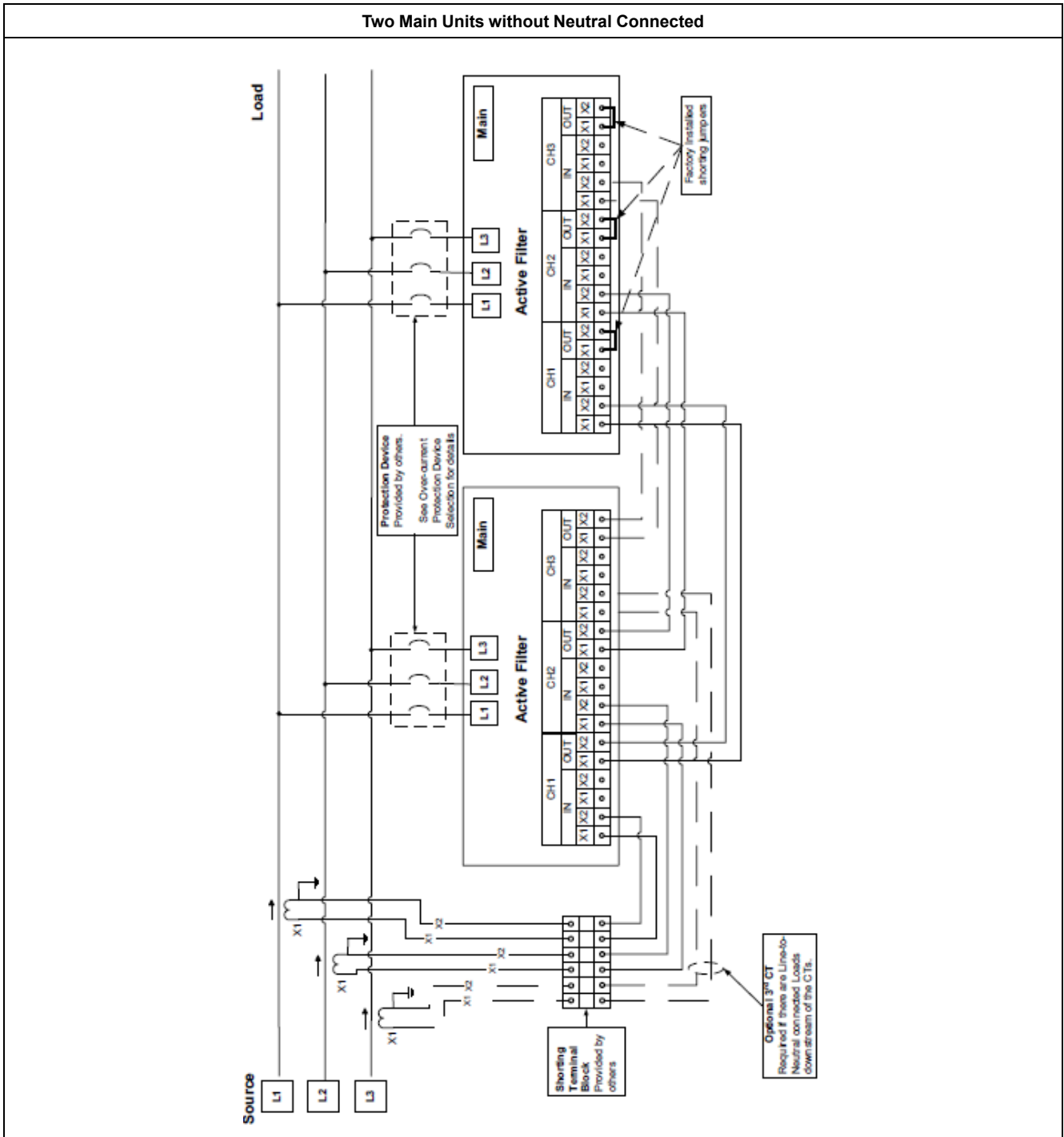

## Parallel Communication

For parallel operation, the units communicate through the RJ-45 connectors labeled 1P and 2P on the Control Board. This is a unique communication protocol that is only to be used for parallel communication. The 2P jack has an RJ-45 termination plug installed at the factory.

### **NOTICE**

#### **EXCESSIVE NOISE IN THE COMMUNICATION CIRCUIT**

When the unit is set to operate in parallel mode, the termination plug must be installed in any RJ-45 jacks that are not used for parallel communication wiring. See the wiring diagrams in this section.

**Failure to follow this instruction can result in communication errors.**

CAT5e cable with all 8 conductors terminated at the RJ-45 connections is required for parallel communication. It is recommended that shielded Cat5e cable be used. Ensure that the total cable length does not exceed 76 m (250 ft). The CAT5e cable with RJ-45 plugs can be purchased as an option. Refer to the catalog for optional paralleling cable part numbers.

**Control Board and CT Board Details**

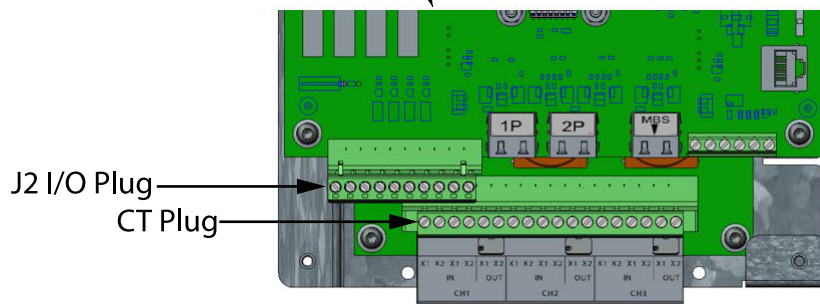
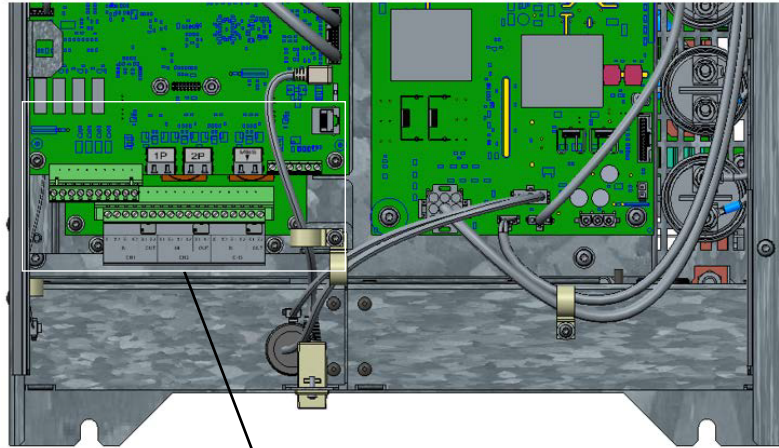

**2 Unit Parallel Communication Wiring Diagram**

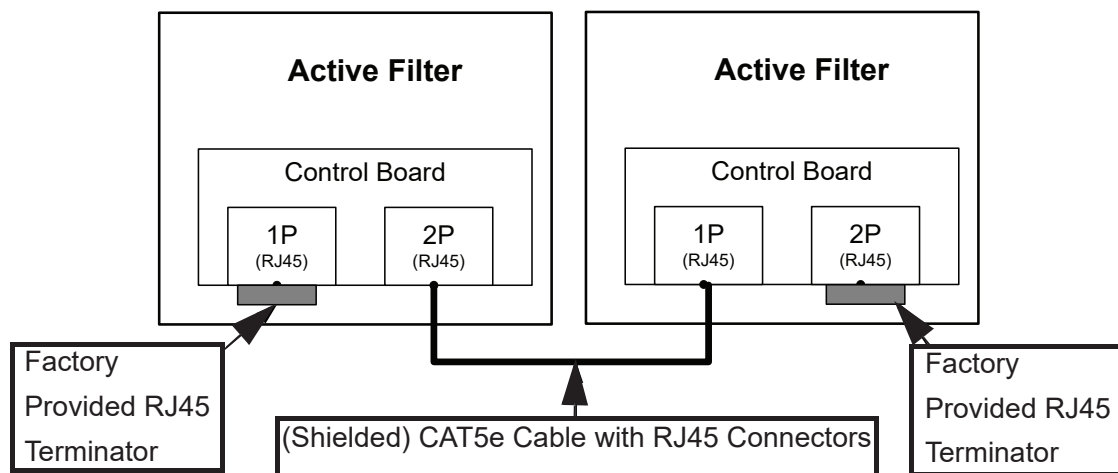

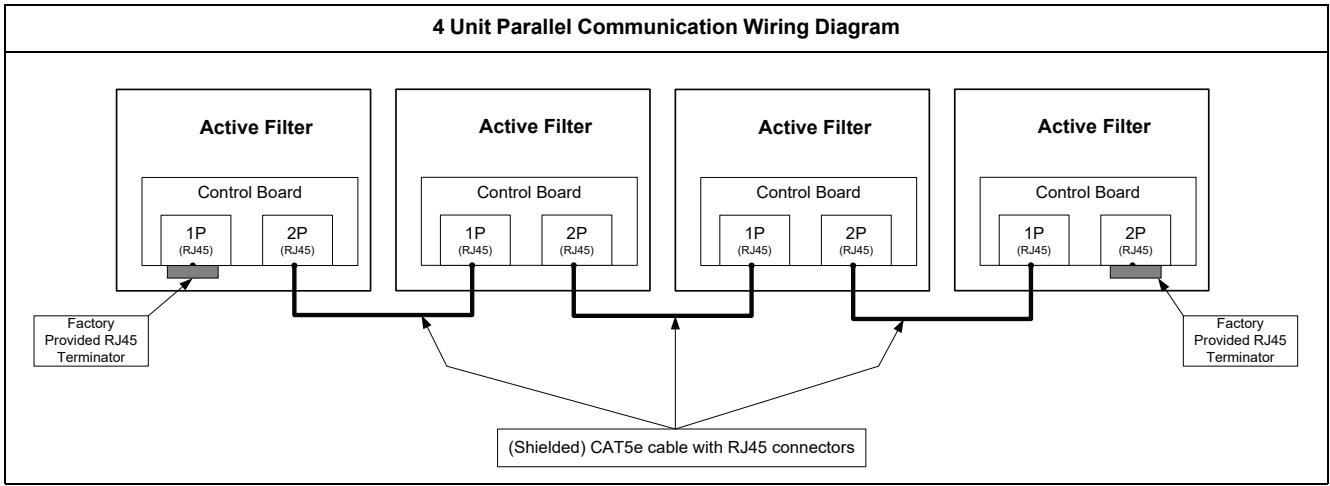

## Control Wiring

### Dry Contact output

Four dry Contact outputs are available at J2 of the Control Board. See *Control Board and CT Board Details*. One common and four switchable outputs are available labeled Q1 to Q4. The four outputs can be programmed to change states on different conditions by the HMI and be set to either normally open or normally closed. See the User Manual for setting the output contacts. Maximum voltage accepted is 250 V AC or 30 V DC with a 0.5 A maximum current per Dry Contact.

### Digital Input Control

Four input controls are available at J2 of the Control Board. See *Control Board and CT Board Details*. One Ground and four inputs labeled I1 to I4. The inputs are at 5 V DC and are grounded to activate. The control function can be programmed by the HMI. See the User Manual for setting the functionality of the input control.

### Modbus TCP/IP

Modbus TCP/IP monitoring is available at the RJ-45 jack on the back of the HMI labeled **ETHERNET**.

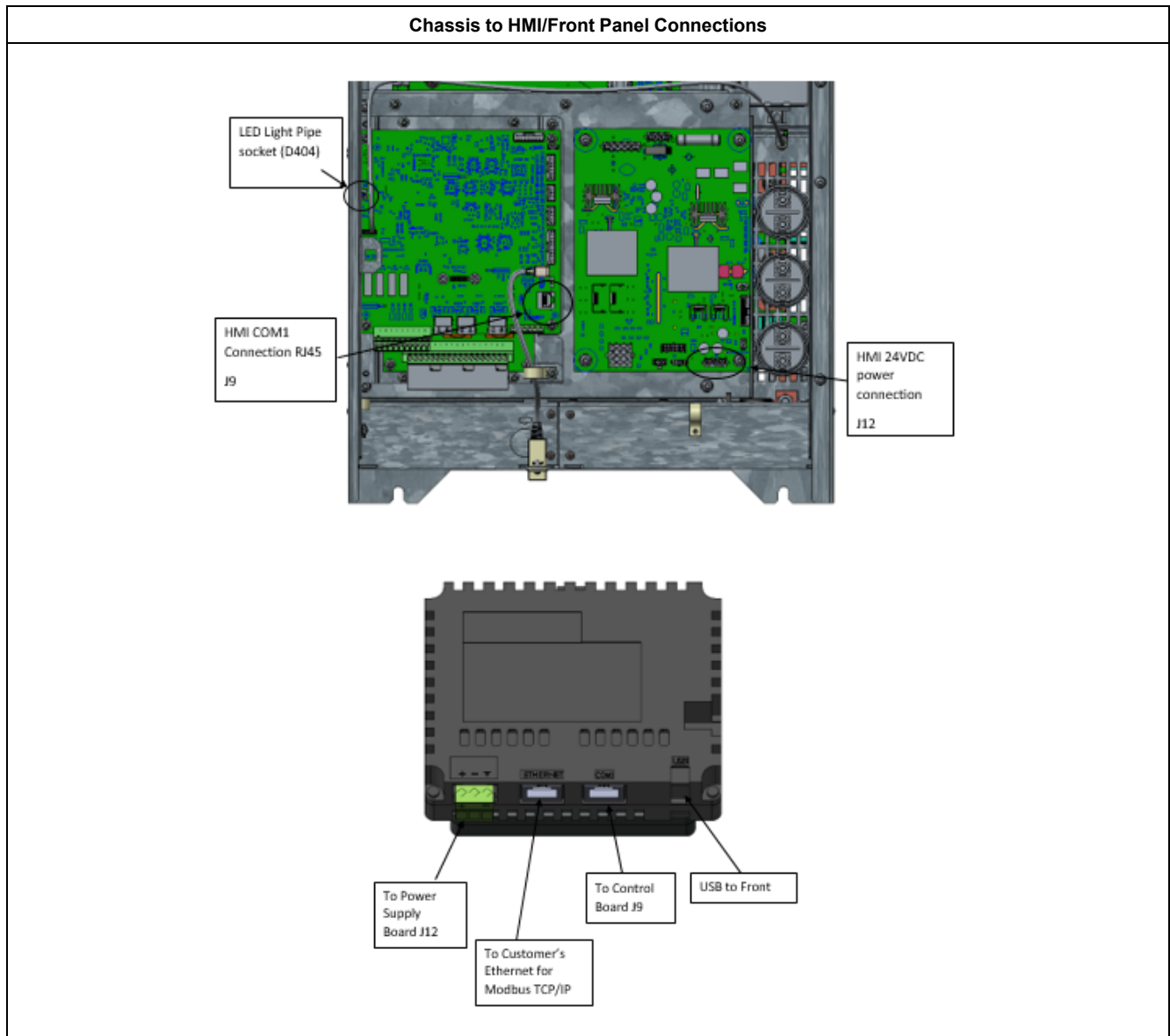

## Modbus Serial

A serial Modbus connection is available through an RJ-45 jack labeled MBS on the control board. Refer to Control Board and CT Board Details. Modbus addresses are provided in the User Manual.

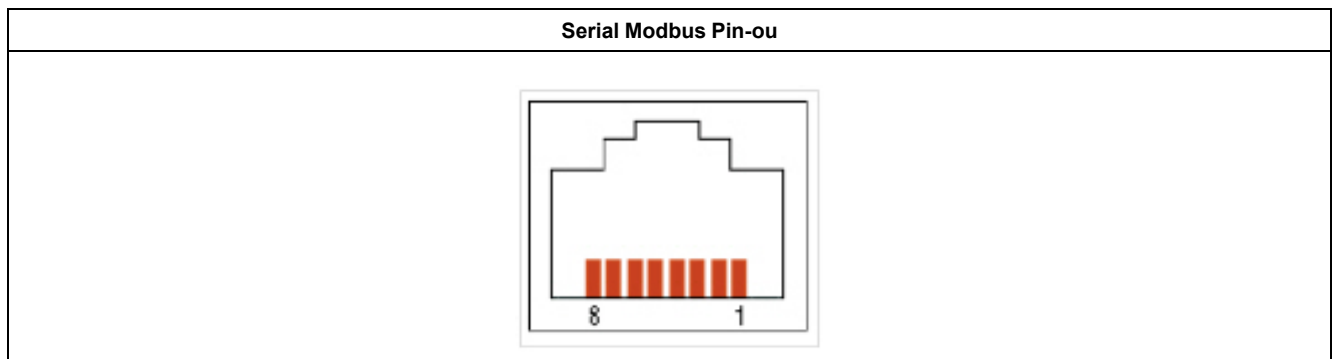

Pin	Signal Name	Direction	Meaning
1	Not connected		
2	Not connected		
3	Not connected		

Pin	Signal Name	Direction	Meaning
4	D1	Input/Output	Transfer data (RS-485)
5	D0	Input/Output	Transfer data (RS-485)
6	Not connected		
7	Not connected		
8	SG		Signal ground

**Control Board and CT Board Details**

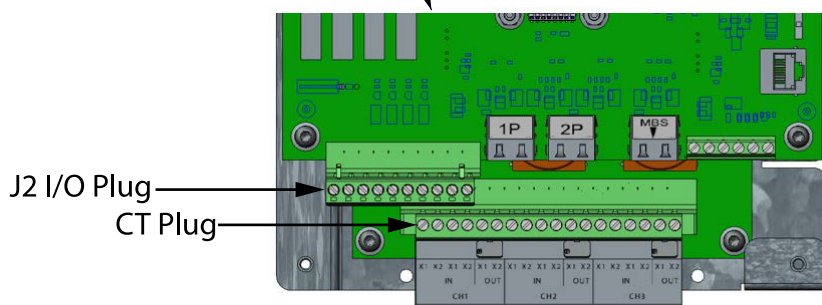
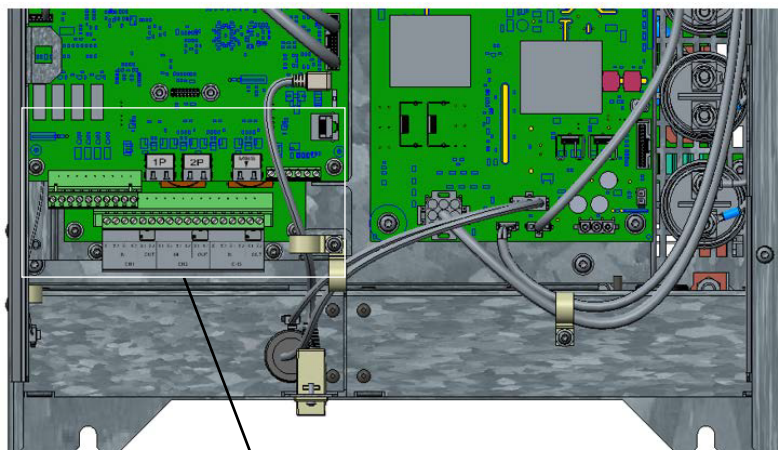

**Control Board J2 Detail**

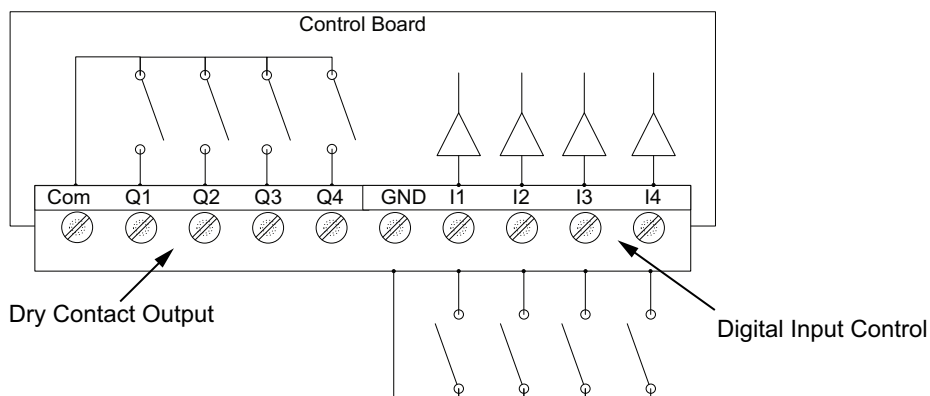

**NOTE:** The control board J2 accepts wire size between 0.5 and 2.5 mm<sup>2</sup> (20 and 12 AWG).

Requirement of wire for Dry Contact output			
Wire cross-sectional area (mm <sup>2</sup> )	Max. length (m)	Min. rated voltage (V AC)	Tightening Torque (Nm)
0.5	31	250	0.5...0.6
1.0	63		
1.5	94		
2.0	126		
2.5	157		

Requirement of wire for Digital Input Control			
Wire cross-sectional area (mm <sup>2</sup> )	Max. length (m)	Min. rated voltage (V AC)	Tightening Torque (Nm)
0.5...2.5	50	250	0.5...0.6

## Pre-commissioning

This chapter provides information for preparation of the active filter for commissioning. Before applying power, read and understand this information thoroughly.

## Instruments Required for Commissioning

- Voltmeter or multimeter
- Clamp-on ammeter
- Megohmmeter

## Pre-energizing Procedure

### **DANGER**

#### **HAZARD OF ELECTRIC SHOCK, EXPLOSION, OR ARC FLASH**

- Apply appropriate personal protective equipment (PPE) and follow safe electrical work practices. See NFPA 70E in the USA, CSA Z462, or applicable local standards.
- This equipment must be installed and serviced only by qualified electrical personnel.
- Do not exceed the device's ratings for maximum limits.
- Ground equipment using the ground connecting point provided before turning on any power supplying this device.
- Turn off all power supplying this device and the equipment in which it is installed before working on the device or equipment.
- After removing power, wait for 15 minutes to allow the capacitors to discharge prior to opening the doors or removing covers.
- Always use a properly rated voltage sensing device to confirm power is off.
- Replace all devices, doors, and covers before turning on power to this equipment.
- Carefully inspect the interior for tools left behind before closing and sealing the door.
- Verify the rating of the neutral conductor for each unit in the system is greater than the neutral current limit setting.

**Failure to follow these instructions will result in death or serious injury.**

## Installation Inspection

Inspect all connections for both power and control wiring. Ensure that the correct termination points have been made for each wire. Ensure that all connections are firmly tightened prior to start-up.

## Pre-Commissioning Checklist

Prior to commissioning the active filter system, the following items must be completed:

- Electrical connections have been made in accordance with local codes.
- Main CTs are installed to measure the current of the system to be corrected.
- The secondary wiring of the main CTs have been connected to the CT board of the active filter.
- If it is a parallel active filter system, CT wiring and parallel communications wiring have been installed between the CT boards of each unit.
- All drives, harmonic generating loads, downstream of the main CTs must have the recommended minimum 3% line reactor or DC choke installed (required for optimum performance when harmonic mode is intended).
- There are no un-isolated capacitors, such as power factor correction capacitors downstream of the main CTs. (required when harmonic mode is intended to operate).
- At least 50% of the anticipated load should be available during the commissioning procedure. To fully test the system integration, all loads supported by the active filter system should be available for operation. The total output current required for the system must be at least 10% of the unit's nameplate rating. For example, a 60 A unit will need a minimum of 6 A Total Output current.
- If backup generation is connected to the active filter, the system should also be tested with the generator supporting the connected loads.

The Field Service Engineer will need to know the following information to commission the active filter:

- Installation location of the main CTs in relationship to the active filter (load or grid, parallel systems must have the main CTs installed on the source side of the active filter system).
- The ratio of the main CTs installed.
- The phase on which each CT is installed.
- Intended mode of operation (Harmonic, Power Factor, Load Balancing).
- Make sure firmware version is the latest version as shown on [se.com](http://se.com) PCSn range page-Software and Firmware section.

## Commissioning procedures

Refer to the User Manual for commissioning procedures. The User Manual is available as a download from our website.

# IP00/Chassis Installation

An IP00 chassis can be installed in other types of enclosures to provide a greater degree of ingress protection. IP00 units can be purchased either as Main units, with an HMI or Expansion units to add units in parallel for additional capacity.

## **⚠️ DANGER**

### **HAZARD OF ELECTRIC SHOCK, EXPLOSION, OR ARC FLASH**

- Apply appropriate personal protective equipment (PPE) and follow safe electrical work practices. See NFPA 70E in the USA, CSA Z462, or applicable local standards.
- This equipment must be installed and serviced only by qualified electrical personnel.
- Do not exceed the device's ratings for maximum limits.
- Ground equipment using the ground connecting point provided before turning on any power supplying this device.
- Turn off all power supplying this device and the equipment in which it is installed before working on the device or equipment.
- After removing power, wait for 15 minutes to allow the capacitors to discharge prior to opening the doors or removing covers.
- Always use a properly rated voltage sensing device to confirm power is off.
- Replace all devices, doors, and covers before turning on power to this equipment.
- Carefully inspect the interior for tools left behind before closing and sealing the door.
- Verify the rating of the neutral conductor for each unit in the system is greater than the neutral current limit setting.

**Failure to follow these instructions will result in death or serious injury.**

The Main units are provided with:

- HMI
- HMI Instruction Bulletin
- LED Light Pipe (2 meters)
- Shielded CAT5e (2 meters)
- 24 VDC HMI power wiring (2 meters)

The Expansion units are provided with LED Light Pipe (2 meters).

When designing the enclosure, the following items must be considered:

- Ensure the enclosure can support the weight of the unit.
- Ensure sufficient airflow is provided to the unit.
- Intake air temperature will remain between 0 °C and 45 °C.
- Ensure that the Service Door can be opened when the maintenance is required.
- Over-current protection device is provided for the unit installed. See *Over-current Protection Device Selection*, page 35.
- The neutral is distributed such that the neutral and over-current protection device are properly selected for the specific application. If not known, the neutral wire and over-current protection device must be sized to accommodate 300% of the unit rating.
- A USB A Male to Female cable will be required for each Main unit installed to allow user access from the front panel. The female end shall be rated to meet or exceed the enclosure environmental rating.
- The LED light pipe shall be made visible to the user.

- Locate the HMI so that it is convenient for operation.
- Make sure that HMI is installed in accordance with the HMI Instruction Bulletin.
- Verify the installation method is in accordance with the provided HMI Instruction Sheet. Mounting instruction for the HMI are available in the HMI Instruction Sheet.

** DANGER**

**HAZARD OF ELECTRIC SHOCK, EXPLOSION, OR ARC FLASH**

Verify that the rating of the neutral conductor for each unit in the system is greater than the neutral current limit setting.

**Failure to follow these instructions will result in death or serious injury.**

PowerLogic™ AccuSine PCSn Chassis Rating	Nominal Voltage Range	Heat Load (W)	Mass (kg)	Air Flow (m³/h)	Exterior Dimensions H x W x D (mm)
20 Amp IP00/Chassis	208 - 415 V -15% / +10%	530	61	560	960 x 440 x 265
30 Amp IP00/Chassis		750	61	560	960 x 440 x 265
50 Amp IP00/Chassis		1200	75	560	960 x 440 x 265
60 Amp IP00/Chassis		1500	75	560	960 x 440 x 265
60 Amp IP00/Chassis expansion		1500	75	560	960 x 440 x 265

## Dimensional Drawings

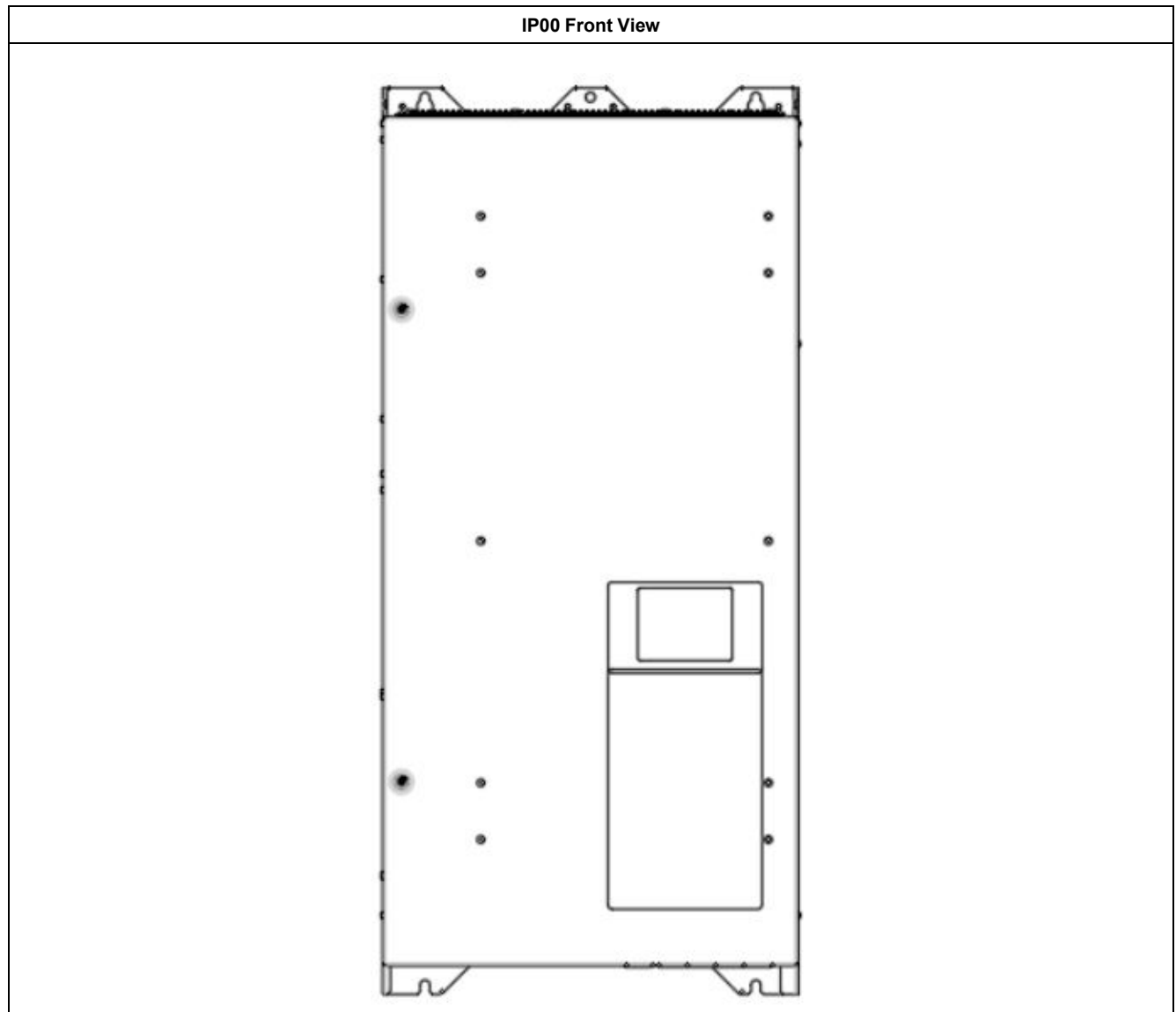

Total height including mounting features 960 mm

Enclosure height 930 mm

Width 440 mm

Zero side clearance

Top and bottom clearance 200 mm each

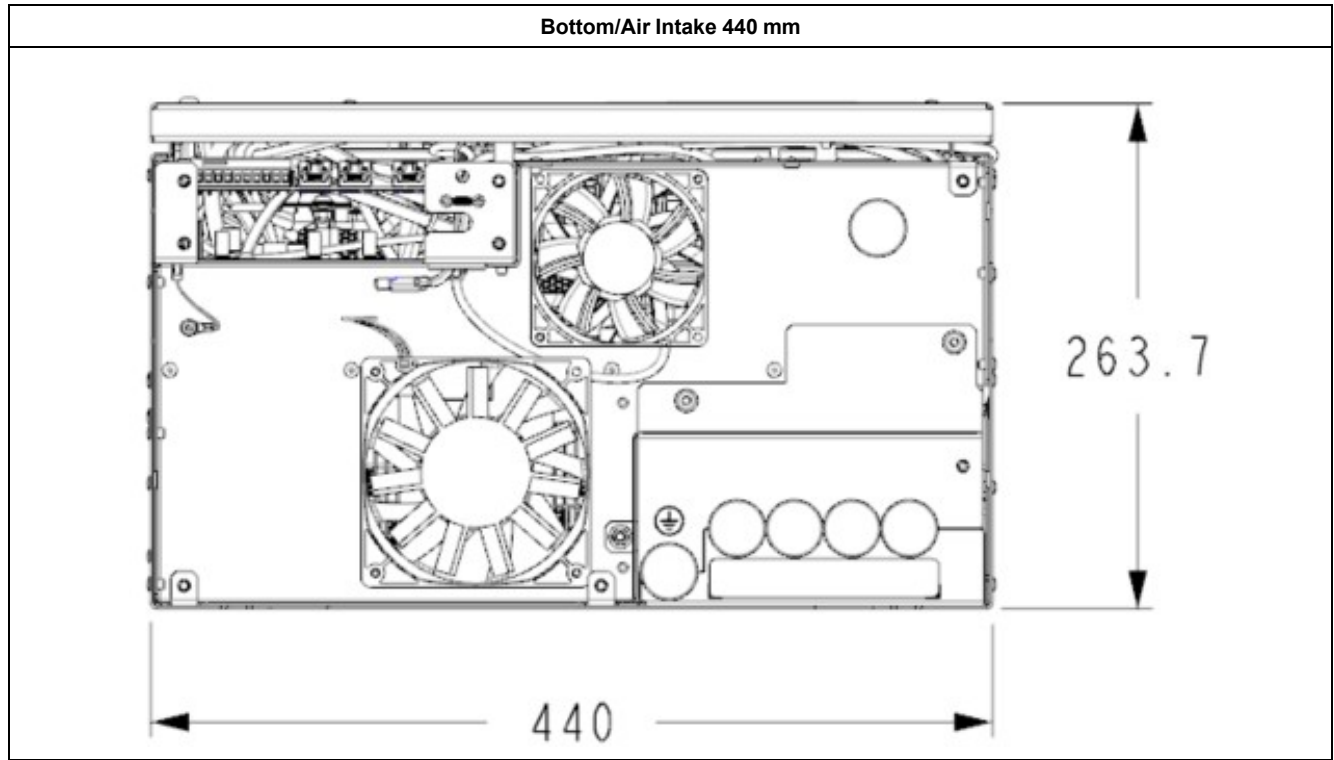

Use M8 hardware to mount the unit in the enclosure.

Mounting hole layout is provided in the drawing below.

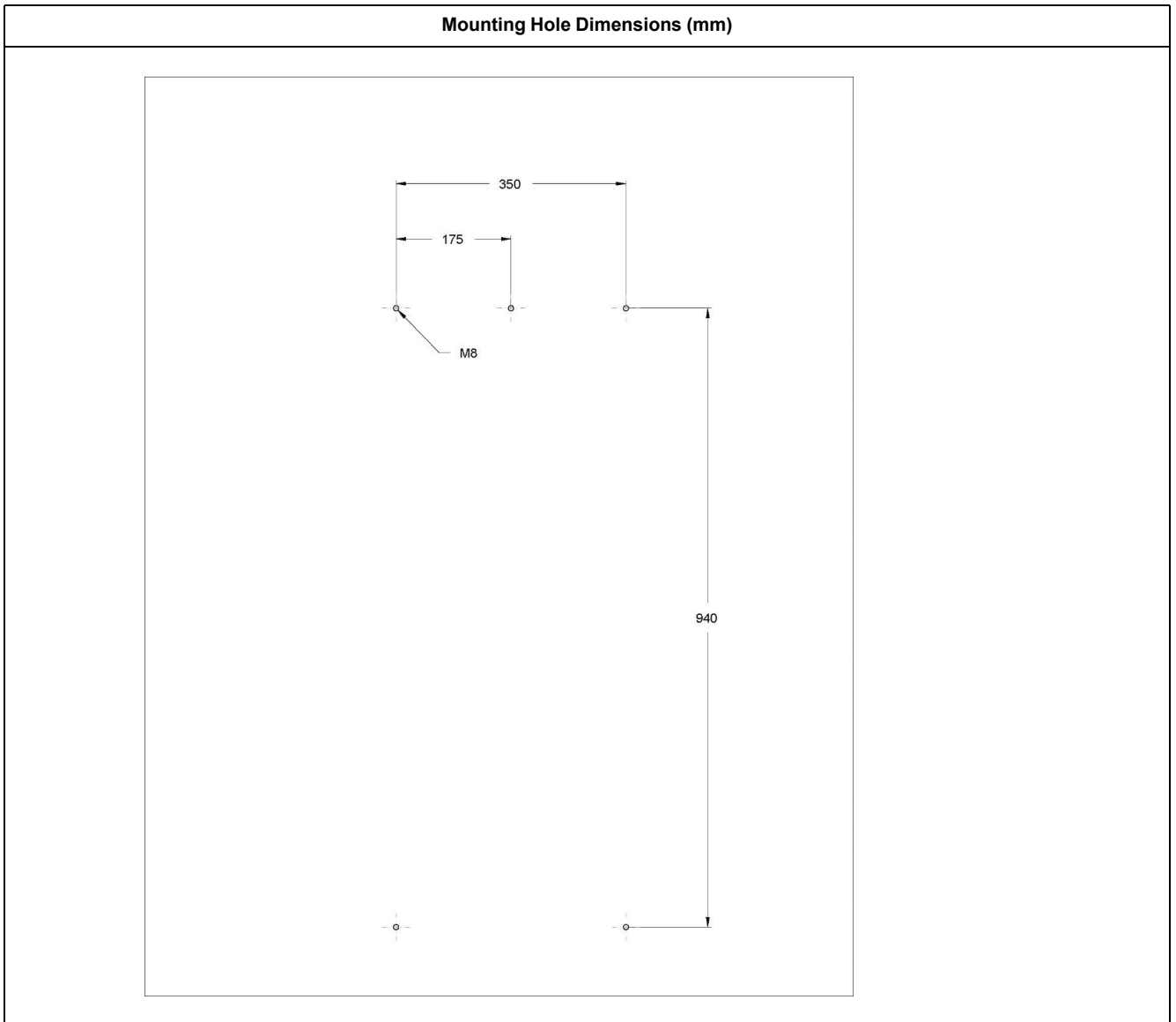

**Wall Mount Main and Expansion Electrical Connections**

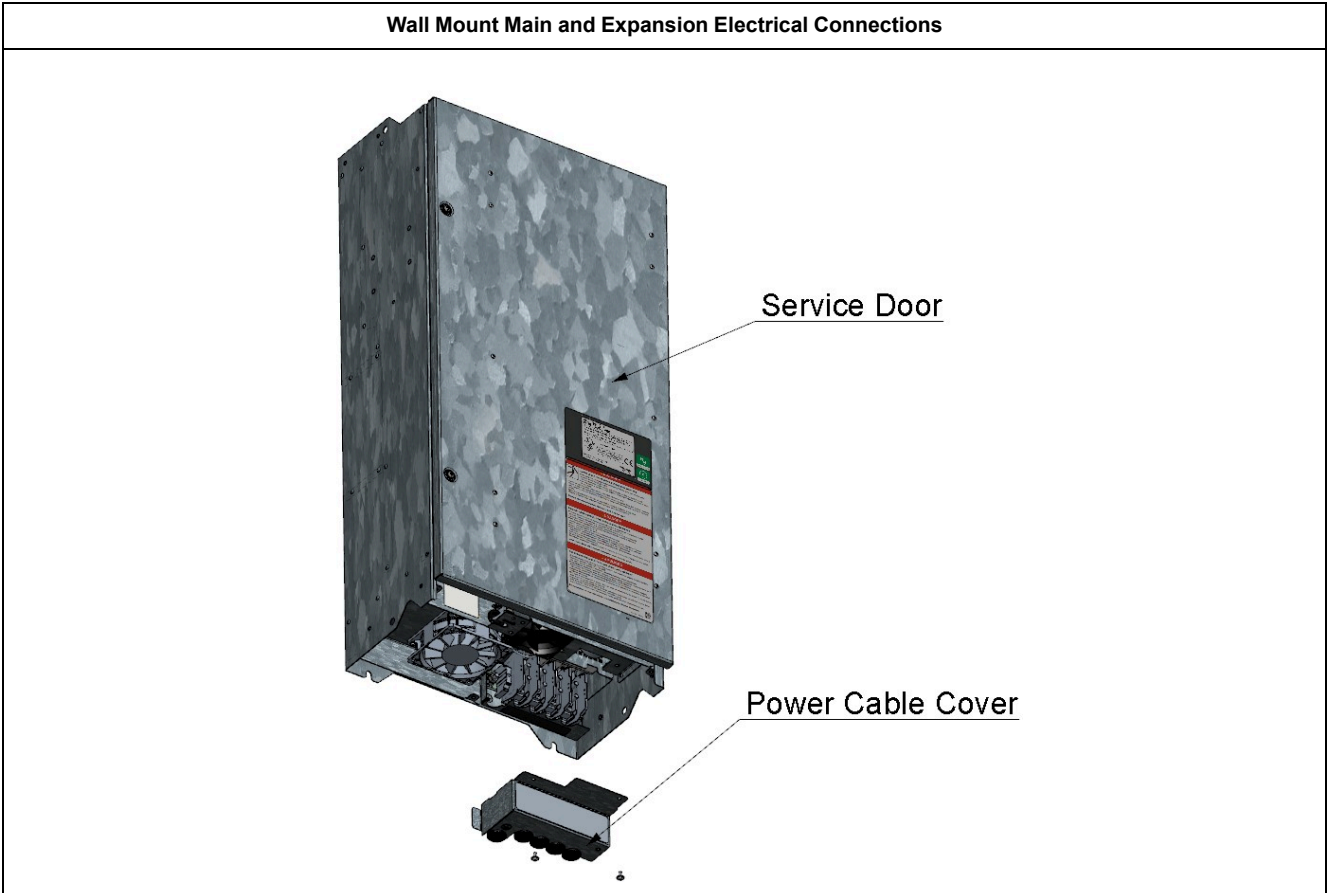

At the bottom of the unit, using a T25 driver, remove the power cable cover.

**Power Cable Cover**

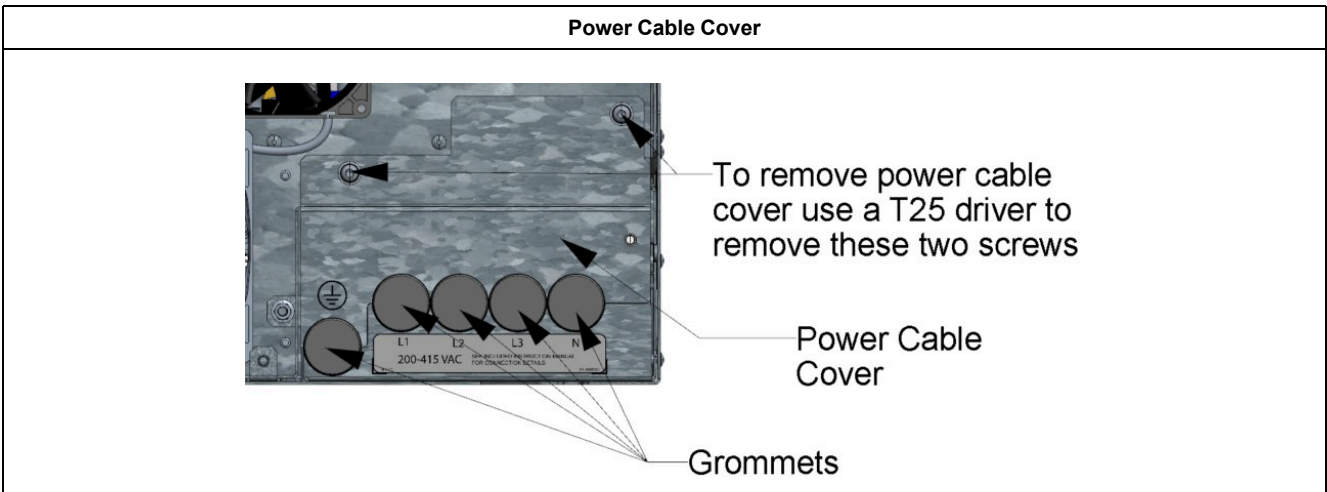

Remove the grommets from the power cable cover.

### Line, Neutral and Ground Cable Connections

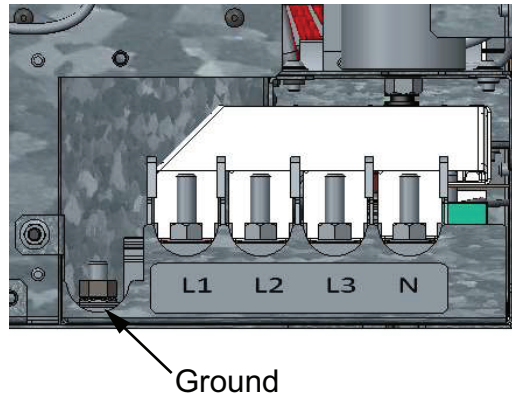

Using a punch or similar, create a hole in the grommet just large enough to allow the line, ground and neutral (if required) wires to pass through the grommet.

Pass one cable through each of the grommets.

Connect an appropriate one-hole crimp lug on the end of each wire for an 8 mm stud.

Reinstall the power cable cover using the T25 hardware. Make sure that the grommets are properly seated.

## ⚠ CAUTION

### INAPPROPRIATE EQUIPMENT OPERATION

For UL Applications, the chassis requires the addition of UL Class T fuses.

- 20 and 30 A units provide a 40 A fuse (PCSNFUSKIT230).
- 50 and 60 A units provide a 80 A fuse (PCSNFUSKIT560).

**Failure to follow these instructions can result in injury or equipment damage.**

## HMI Connections

When making the HMI connections, make sure it is mounted in a location that is accessible for users. HMI mounting instructions are provided in the box containing the HMI and interconnection wiring.

## Chassis to HMI/Front panel connections

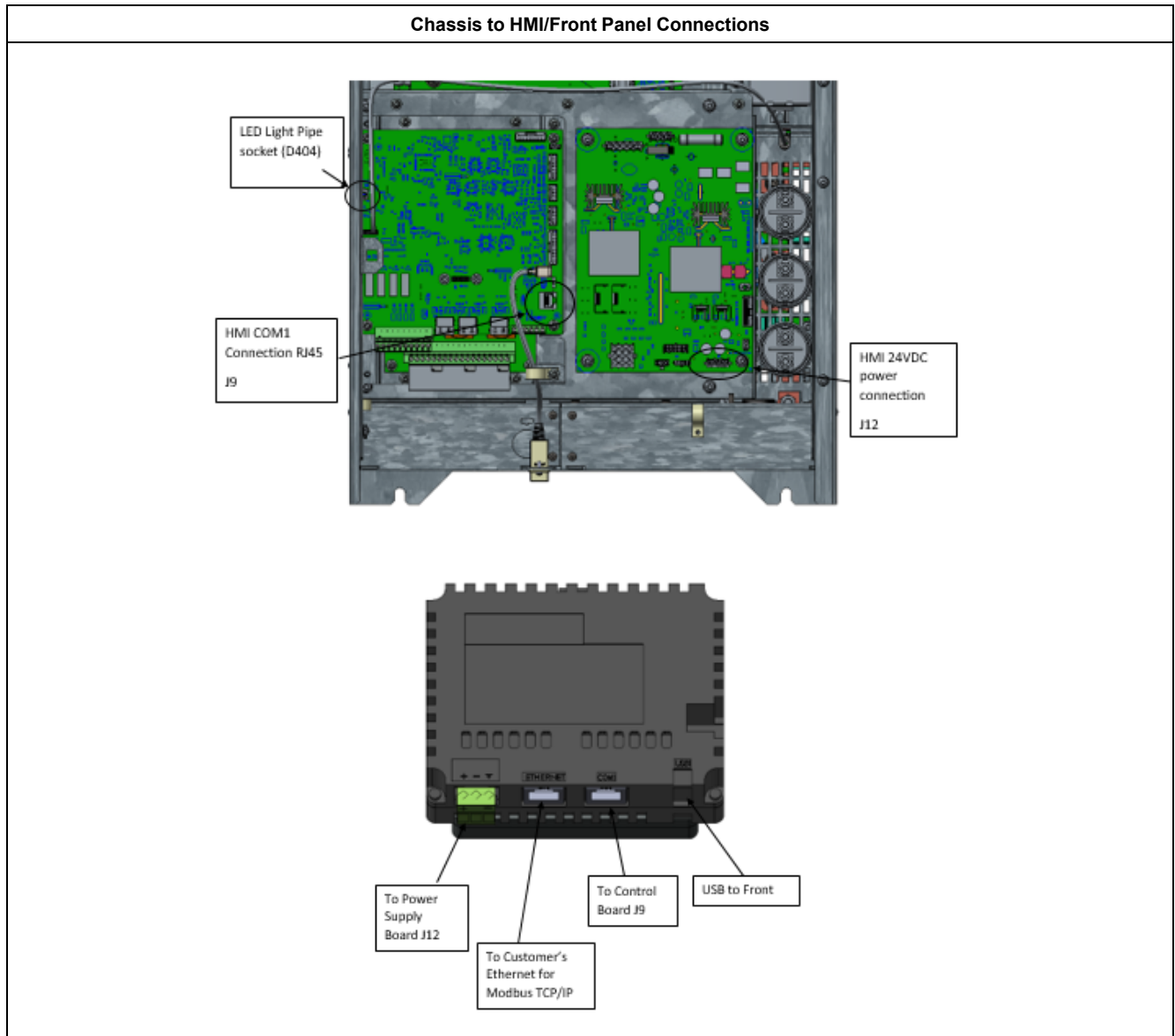

### HMI power connections

- Connect the red (+) to the +
- Connect the black (-) to the -
- Connect the green to the ground

### LED light pipe connections

- Drill 6.5 mm hole, pass the light pipe through the hole seating the light pipe lens.
- Route the light pipe into the control board D404.
- Cut the light pipe to length and insert the light pipe into light pipe socket on control board D404.

## 24 Volt Power Connection

1. Connect the HMI power cable, which has a green connector on one end and a black connector on the other end.
  - a. Connect the green connector to the chassis green connector labeled PWR.
  - b. Connect the black connector to the HMI labeled DC24 V.
2. Provide a ground wire from the HMI ground connection to the enclosure/ chassis ground. The ground wire size must be between 0.2 and 1.5 mm<sup>2</sup> (24 - 16 AWG) with a temperature rating of 75 °C (167 °F).
3. Connect the provided 3 pin connector to J12 of the power supply board.

## Ethernet

Connect the green CAT5 cable labeled ETH to the active filter front connection labeled ETH.

## Communication

- Connect the black CAT5 cable labeled COM to the active filter front connection labeled COM.
- Connect the other end to the RJ45 connector on the HMI labeled COM1.

## Enclosure mount USB

Provide a female USB that can be accessed by the user. Use a panel mount type A female to standard type A male. Connect the standard type A male to the USB A jack on the back of the HMI. Make sure that the panel mount type A female end is accessible to the end user. Use a USB cable that meets the requirement for the type of enclosure utilized.

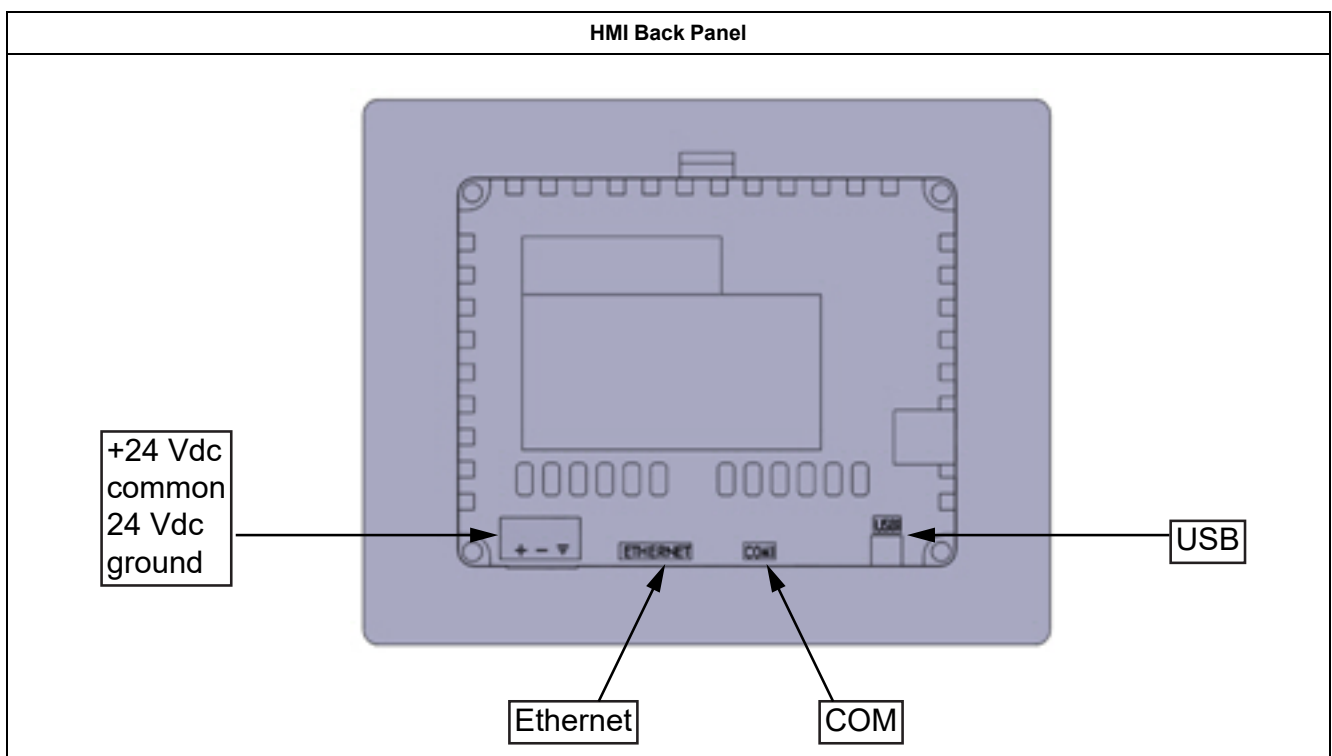



**Imported in the UK by:**

Schneider Electric Limited  
Stafford Park 5 Telford, TF3 3BL  
United Kingdom

**Importado en México por:**

Schneider Electric México, S.A. de C.V.  
Calz. Javier Rojo Gómez 1121-A  
Col. Gpe. del Moral 09300 México, D.F.  
Tel. 5804-5000  
[www.se.com/mx](http://www.se.com/mx)

**Schneider Electric**

35 rue Joseph Monier  
92500 Rueil Malmaison  
France  
+33 (0)141297000  
[www.se.com](http://www.se.com)

As standards, specifications, and design change from time to time, please ask for confirmation of the information given in this publication.

© 2024 Schneider Electric. All rights reserved.