

DUAL DIMENSIONS: INCHES
MILLIMETERS

HEAVY DUTY SAFETY SWITCH
VISIBLE BLADE TYPE
60 AMPERE
ENCLOSURE - NEMA TYPE 1

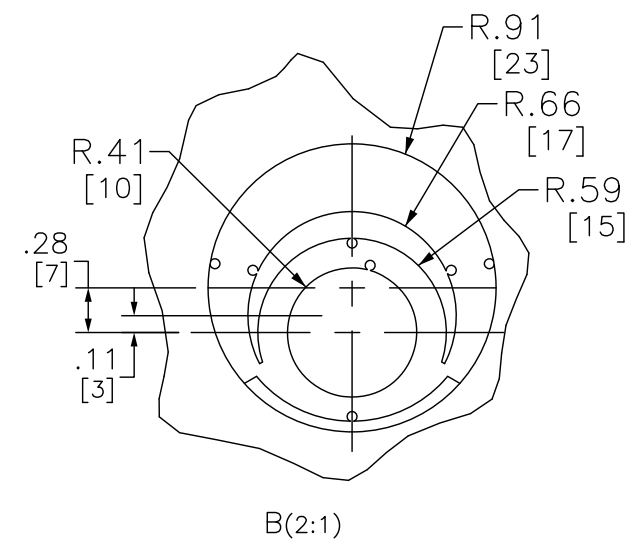

DWG# VHU362GL PG 1
NO.

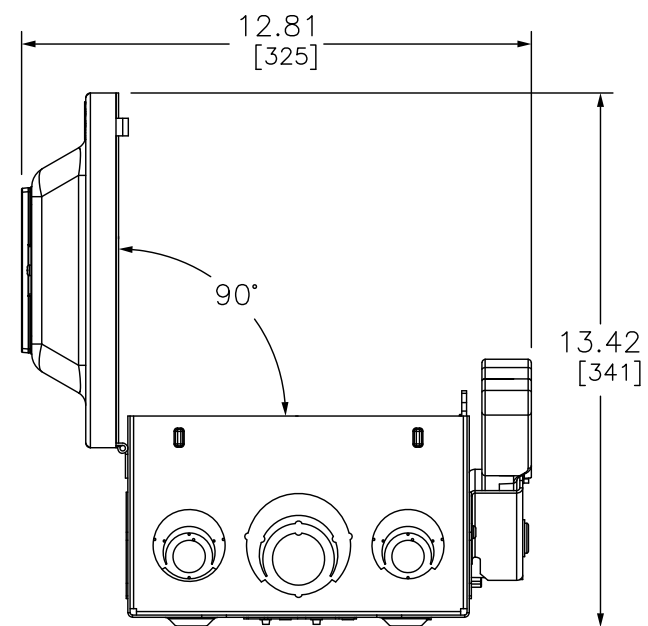
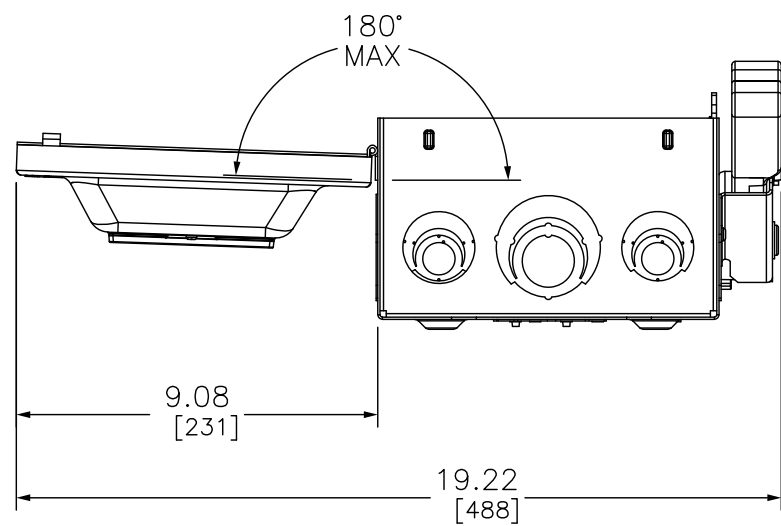
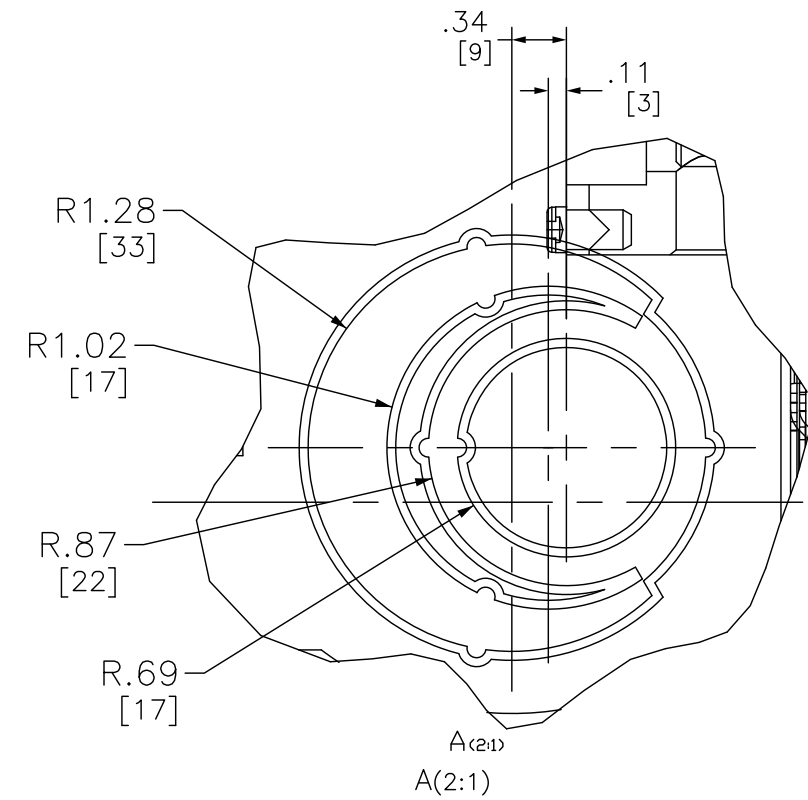
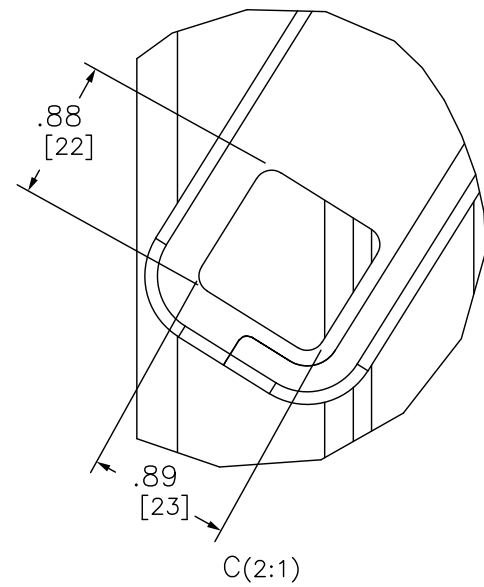
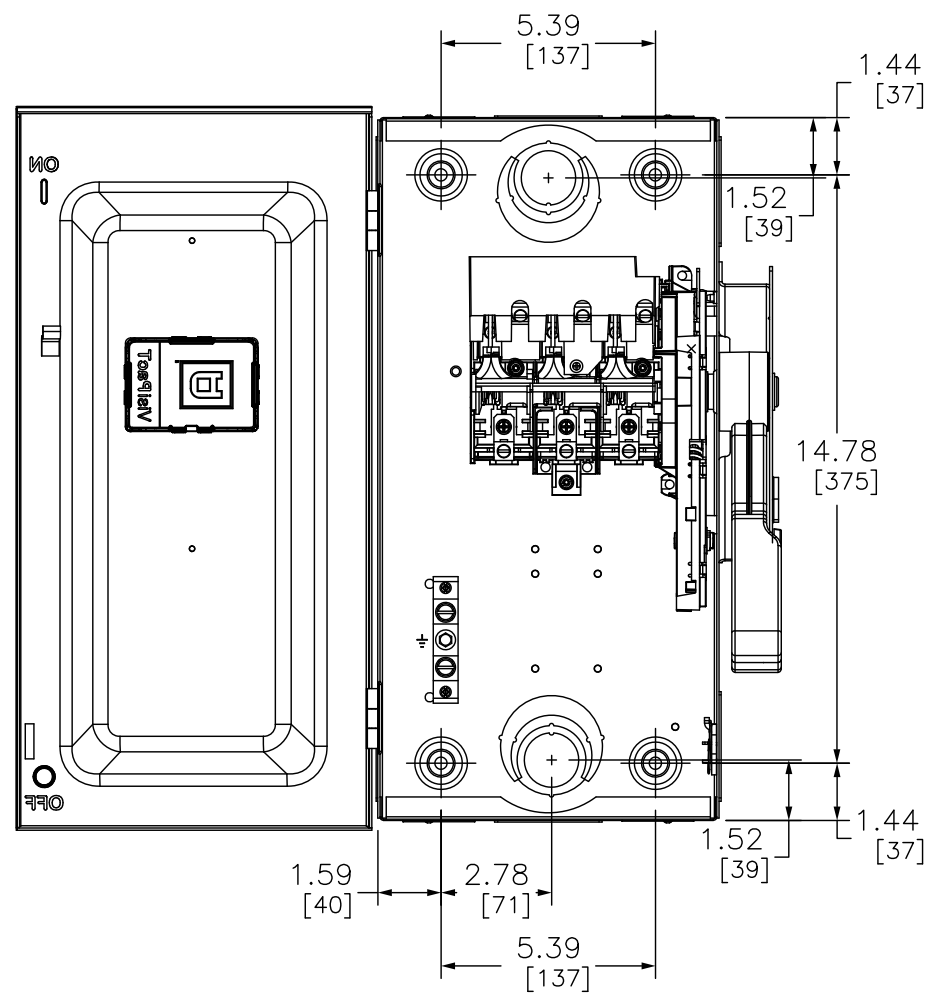

DUAL DIMENSIONS: INCHES
MILLIMETERS

HEAVY DUTY SAFETY SWITCH
VISIBLE BLADE TYPE
60 AMPERE
ENCLOSURE - NEMA TYPE 1



DWG# VHU362GL PG 2
NO.

LINE SIDE

ACCEPTS: 12-2 AWG AL
14-2 AWG CU

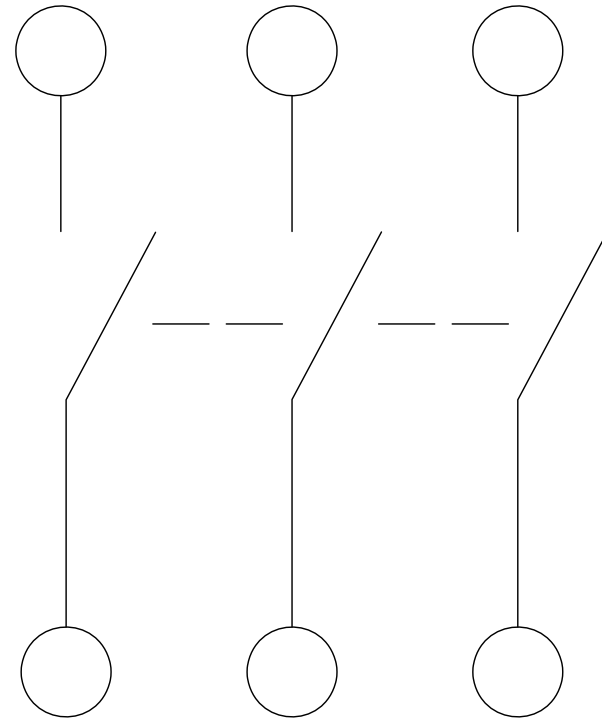

LOAD SIDE

ACCEPTS: 12-2 AWG AL
14-2 AWG CU

NOTES:

FINISH – COLD ROLLED STEEL, GRAY BAKED ENAMEL

LUGS SUITABLE FOR 60~C OR 75~C AL-CU CONDUCTORS

SHORT CIRCUIT CURRENT RATINGS:

10,000 RMS SYMMETRICAL AMPERES WHEN USED IN CONJUNCTION WITH CLASS H OR K
200,000 RMS SYMMETRICAL AMPERES WHEN USED IN CONJUNCTION WITH CLASS R, J
OR T FUSES.

cULus LISTED – FILE E2875

SEISMIC NOTES:

USE (4) 1/4" DIA GRADE 5 STEEL MOUNTING BOLTS AT SWITCH MOUNTING HOLES. MAX
CONFIGURED WEIGHT 20 LB FOR THE PURPOSE OF DETERMINING SEISMIC ANCHORAGE
REQUIREMENTS. FOR ALL OTHER APPLICATIONS, CONTACT SQUARE D COMPANY.

CATALOG NUMBER	VOLTAGE RATING	AMPERAGE RATING	ENCLOSURE RATING
VHU362GL	600 VAC/VDC	60A	TYPE 1

HORSEPOWER RATINGS			
VOLTS	Ø	STD	MAX
120V~	1	--	5
*240V~	1	--	10
**240V~	3	--	15
+240V~	3	--	20
*480V~	1	--	25
**480V~	3	--	30
+480V~	3	--	50
*600V~	1	--	30
600V~	3	--	60
*125V=	--	--	5
*250V=	--	--	10
*600V=	--	--	30

*USE BOTH OUTER SWITCHING POLES

**IF CORNER GROUNDED DELTA, INSTALL NEUTRAL AND USE OUTER SWITCHING POLES FOR UNGROUNDED CONDUCTORS

+NOT APPLICABLE FOR CORNER GROUNDED

ACCESORIES		
KIT	VOLTAGE	PART NUMBER
ELECTRICAL INTERLOCK	600V	EIK1, EIK2
	240V	EIK031, EIK032
CLASS R FUSE KITS	600V	RFK03H, RFK06
	240V	RFK03L
INTERNAL BARRIER	600V	SS06
	240V	SS03
FUSE PULLER	600V	FPK0610
	240V	FPK03
SOLID NEUTRAL ASSEMBLY	600V	SN0610 FOR AL SN0610C FOR CU
	240V	SN03 FOR AL SN03C FOR CU
EQUIPMENT GROUNDING KIT	600V	GTK0610 FOR AL GTK0610C FOR CU
	240V	GTK03 FOR AL GTK03C FOR CU
TOUCH UP PAINT	600V & 240V	PK49SP
LOCK OFF/ON	600V	LOGK2
	240V	LOGK1
COPPER LUGS	600V & 240V	CL0306F

SWITCH RATING (A)	FUSE OR CIRCUIT BREAKER TYPE	240 VAC	480 VAC	600 VAC	250VDC
WITH UPSTREAM FUSE PROTECTION					
ALL	H,K	10 kA	10 kA	10 kA	UP TO 10KA
	R, T, J, L	200 kA	200 kA	200 kA	
WITH UPSTREAM FUSE PROTECTION					
ALL	ANY BRAND CIRCUIT BREAKER	10 kA	10 kA	10 kA	UP TO 10KA
60A	POWERPACT HD	25 kA	18 kA	14 kA	UP TO 10KA
60A	POWERPACT HG	65 kA	35 kA	18 kA	UP TO 10KA
60A	POWERPACT HJ	65 kA	35 kA	25 kA	UP TO 10KA
60A	POWERPACT HL	65 kA	35 kA	35 kA	UP TO 10KA
60A	POWERPACT HR	65 kA	35 kA	35 kA	UP TO 10KA
60A	FA	14 kA	14 kA	14 kA	UP TO 10KA
60A	FH	18 kA	18 kA	18 kA	UP TO 10KA

SWITCH RATING (A)	FUSE OR CIRCUIT BREAKER TYPE	240VAC	480VAC	600Y/347 VAC	250VDC
WITH UPSTREAM CIRCUIT BREAKER PROTECTION					
60A	POWERPACT BD	25 kA	18 kA	14 kA	UP TO 10KA
60A	POWERPACT BG	65 kA	35 kA	18 kA	UP TO 10KA
60A	POWERPACT BJ & BK	65 kA	35 kA	25 kA	UP TO 10KA

HEAVY DUTY SAFETY SWITCH
VISIBLE BLADE TYPE
60 AMPERE
ENCLOSURE – NEMA TYPE 1



DWG# VHU362GL PG 3
NO.