

Galaxy VL

For UL

Technical Specifications

Latest updates are available on the Schneider Electric website
5/2024



Legal Information

The information provided in this document contains general descriptions, technical characteristics and/or recommendations related to products/solutions.

This document is not intended as a substitute for a detailed study or operational and site-specific development or schematic plan. It is not to be used for determining suitability or reliability of the products/solutions for specific user applications. It is the duty of any such user to perform or have any professional expert of its choice (integrator, specifier or the like) perform the appropriate and comprehensive risk analysis, evaluation and testing of the products/solutions with respect to the relevant specific application or use thereof.

The Schneider Electric brand and any trademarks of Schneider Electric SE and its subsidiaries referred to in this document are the property of Schneider Electric SE or its subsidiaries. All other brands may be trademarks of their respective owner.

This document and its content are protected under applicable copyright laws and provided for informative use only. No part of this document may be reproduced or transmitted in any form or by any means (electronic, mechanical, photocopying, recording, or otherwise), for any purpose, without the prior written permission of Schneider Electric.

Schneider Electric does not grant any right or license for commercial use of the document or its content, except for a non-exclusive and personal license to consult it on an "as is" basis.

Schneider Electric reserves the right to make changes or updates with respect to or in the content of this document or the format thereof, at any time without notice.

To the extent permitted by applicable law, no responsibility or liability is assumed by Schneider Electric and its subsidiaries for any errors or omissions in the informational content of this document, as well as any non-intended use or misuse of the content thereof.

Access to Your Product Manuals Online

Find the UPS Manuals, Submittal Drawings, and Other Documentation for Your Specific UPS Here:

In your web browser, type in <https://www.go2se.com/ref=> and the commercial reference for your product.

Example: <https://www.go2se.com/ref=GVL200K500DS>

Find the UPS Manuals, Relevant Auxiliary Product Manuals, and Option Manuals Here:

Scan the code to go to the Galaxy VL online manual portal:

UL (480 V)



https://www.productinfo.schneider-electric.com/galaxyvl_ul/

Here you can find your UPS installation manual, UPS operation manual, and UPS technical specifications, and you can also find installation manuals for your auxiliary products and options.

This online manual portal is available on all devices and offers digital pages, search functionality across the different documents in the portal, and PDF download for offline use.

Learn More About the Galaxy VL Here:

Go to <https://www.se.com/ww/en/product-range/22545656> to learn more about this product.

Table of Contents

Important Safety Instructions — SAVE THESE	
INSTRUCTIONS	7
FCC Statement	8
Safety Precautions	8
ENERGY STAR Qualification.....	10
Model List.....	11
Single System Overview.....	12
Parallel System Overview.....	13
Input Voltage Window	14
Inverter Short Circuit Capabilities (Bypass not Available)	15
Efficiency for 480 V.....	18
Derating Due to Load Power Factor.....	20
Batteries	21
Common Battery	21
End of Discharge Voltage	21
Standard VRLA Voltage Levels	22
Compliance.....	23
Regional Seismic Compliance	23
Communication and Management.....	24
EPO	24
Configurable Input Contacts and Output Relays.....	25
Requirements for a Third Party Battery Solution.....	26
Third Party Battery Breaker Requirements.....	26
Guidance for Organizing Battery Cables.....	27
Specifications	28
Specifications for 200 kW UPS	28
Specifications for 250 kW UPS	32
Specifications for 300 kW UPS	36
Specifications for 350 kW UPS	40
Specifications for 400 kW UPS	44
Specifications for 450 kW UPS	48
Specifications for 500 kW UPS	52
Upstream and Downstream Protection for UL	56
Recommended Cable Sizes for UL	58
Recommended Bolt and Lug Sizes for UL.....	62
Torque Specifications.....	63
Physical	64
UPS Shipping Weights and Dimensions	64
UPS Weights and Dimensions	64
Clearance	65
Environment.....	66
Heat Dissipation for 480 V in BTU/hr	66
Heat Dissipation for Transformer Cabinets in BTU/hr	67
Airflow Values	68
Drawings	69

Galaxy VL 200-500 kW 480 V UPS	69
Options	70
Configuration Options	70
Hardware Options.....	71
Weights and Dimensions for Options.....	73
Maintenance Bypass Cabinet Shipping Weights and Dimensions	73
Maintenance Bypass Cabinet Weights and Dimensions.....	73
Input and Output Transformer Cabinet Shipping Weights and Dimensions	73
Input and Output Transformer Cabinet Weights and Dimensions	73
Bottom Entry Cabinet Shipping Weight and Dimensions	74
Bottom Entry Cabinet Weight and Dimensions	74
Limited Factory Warranty.....	75

Important Safety Instructions — SAVE THESE INSTRUCTIONS

Read these instructions carefully and look at the equipment to become familiar with it before trying to install, operate, service or maintain it. The following safety messages may appear throughout this manual or on the equipment to warn of potential hazards or to call attention to information that clarifies or simplifies a procedure.



The addition of this symbol to a “Danger” or “Warning” safety message indicates that an electrical hazard exists which will result in personal injury if the instructions are not followed.



This is the safety alert symbol. It is used to alert you to potential personal injury hazards. Obey all safety messages with this symbol to avoid possible injury or death.

DANGER

DANGER indicates a hazardous situation which, if not avoided, **will result in death or serious injury.**

Failure to follow these instructions will result in death or serious injury.

WARNING

WARNING indicates a hazardous situation which, if not avoided, **could result in death or serious injury.**

Failure to follow these instructions can result in death, serious injury, or equipment damage.

CAUTION

CAUTION indicates a hazardous situation which, if not avoided, **could result in minor or moderate injury.**

Failure to follow these instructions can result in injury or equipment damage.

NOTICE

NOTICE is used to address practices not related to physical injury. The safety alert symbol shall not be used with this type of safety message.

Failure to follow these instructions can result in equipment damage.

Please Note

Electrical equipment should only be installed, operated, serviced, and maintained by qualified personnel. No responsibility is assumed by Schneider Electric for any consequences arising out of the use of this material.

A qualified person is one who has skills and knowledge related to the construction, installation, and operation of electrical equipment and has received safety training to recognize and avoid the hazards involved.

FCC Statement

NOTE: This equipment has been tested and found to comply with the limits for a Class A digital device, pursuant to Part 15 of the FCC Rules. These limits are designed to provide reasonable protection against harmful interference when the equipment is operated in a commercial environment. This equipment generates, uses, and can radiate radio frequency energy and, if not installed and used in accordance with the instruction manual, may cause harmful interference to radio communications. Operation of this equipment in a residential area is likely to cause harmful interference in which case the user will be required to correct the interference at his own expense.

Any changes or modifications not expressly approved by the party responsible for compliance could void the user's authority to operate the equipment.

Safety Precautions

⚠ DANGER

HAZARD OF ELECTRIC SHOCK, EXPLOSION, OR ARC FLASH

All safety instructions in this document must be read, understood and followed.

Failure to follow these instructions will result in death or serious injury.

⚠ DANGER

HAZARD OF ELECTRIC SHOCK, EXPLOSION, OR ARC FLASH

Read all instructions in the installation manual before installing or working on this UPS system.

Failure to follow these instructions will result in death or serious injury.

⚠ DANGER

HAZARD OF ELECTRIC SHOCK, EXPLOSION, OR ARC FLASH

Do not install the UPS system until all construction work has been completed and the installation room has been cleaned.

Failure to follow these instructions will result in death or serious injury.

⚠ DANGER

HAZARD OF ELECTRIC SHOCK, EXPLOSION, OR ARC FLASH

- The product must be installed according to the specifications and requirements as defined by Schneider Electric. It concerns in particular the external and internal protections (upstream breakers, battery breakers, cabling, etc.) and environmental requirements. No responsibility is assumed by Schneider Electric if these requirements are not respected.
- After the UPS system has been electrically wired, do not start up the system. Start-up must only be performed by Schneider Electric.

Failure to follow these instructions will result in death or serious injury.

⚠ DANGER

HAZARD OF ELECTRIC SHOCK, EXPLOSION, OR ARC FLASH

The UPS system must be installed according to local and national regulations. Install the UPS according to:

- IEC 60364 (including 60364–4–41 - protection against electric shock, 60364–4–42 - protection against thermal effect, and 60364–4–43 - protection against overcurrent), **or**
- NEC NFPA 70, **or**
- Canadian Electrical Code (C22.1, Part 1)

depending on which one of the standards apply in your local area.

Failure to follow these instructions will result in death or serious injury.

⚠ DANGER

HAZARD OF ELECTRIC SHOCK, EXPLOSION, OR ARC FLASH

- Install the UPS system in a temperature controlled indoor environment free of conductive contaminants and humidity.
- Install the UPS system on a non-flammable, level and solid surface (e.g. concrete) that can support the weight of the system.

Failure to follow these instructions will result in death or serious injury.

⚠ DANGER

HAZARD OF ELECTRIC SHOCK, EXPLOSION, OR ARC FLASH

The UPS is not designed for and must therefore not be installed in the following unusual operating environments:

- Damaging fumes
- Explosive mixtures of dust or gases, corrosive gases, or conductive or radiant heat from other sources
- Moisture, abrasive dust, steam or in an excessively damp environment
- Fungus, insects, vermin
- Salt-laden air or contaminated cooling refrigerant
- Pollution degree higher than 2 according to IEC 60664-1
- Exposure to abnormal vibrations, shocks, and tilting
- Exposure to direct sunlight, heat sources, or strong electromagnetic fields

Failure to follow these instructions will result in death or serious injury.

⚠ DANGER

HAZARD OF ELECTRIC SHOCK, EXPLOSION, OR ARC FLASH

Do not drill or cut holes for cables or conduits with the gland plates installed and do not drill or cut holes in close proximity to the UPS.

Failure to follow these instructions will result in death or serious injury.

⚠ WARNING

HAZARD OF ARC FLASH

Do not make mechanical changes to the product (including removal of cabinet parts or drilling/cutting of holes) that are not described in the Installation Manual.

Failure to follow these instructions can result in death, serious injury, or equipment damage.

▲ CAUTION**RISK OF HOT SURFACE**

The outer plates of the cabinet can exceed temperatures of 65 °C (149 °F) at 50 °C (122 °F) ambient room temperature, if the air filter(s) in the front door is clogged. Replace the air filter regularly as described in the UPS operation manual.

Failure to follow these instructions can result in injury or equipment damage.

NOTICE**RISK OF OVERHEATING**

Respect the space requirements around the UPS system and do not cover the product's ventilation openings when the UPS system is in operation.

Failure to follow these instructions can result in equipment damage.

NOTICE**RISK OF EQUIPMENT DAMAGE**

Do not connect the UPS output to regenerative load systems including photovoltaic systems and speed drives.

Failure to follow these instructions can result in equipment damage.

ENERGY STAR Qualification



Select models are ENERGY STAR® qualified. For more information on your specific model go to www.se.com.

Model List



- Galaxy VL UPS 200 kW scalable to 500 kW, 400/480V, start-up 5x8 (GVL200K500DS)
- Galaxy VL UPS 300 kW scalable to 500 kW, 400/480V, start-up 5x8 (GVL300K500DS)
- Galaxy VL UPS 400 kW scalable to 500 kW, 400/480V, start-up 5x8 (GVL400K500DS)
- Galaxy VL UPS 500 kW, 400/480V, start-up 5x8 (GVL500KDS)

Single System Overview

UIB	Unit input breaker
SSIB	Static switch input breaker
UOB	Unit output breaker
BB	Battery breaker

NOTE: The word 'breaker' is used as a generic term covering circuit breakers and switches.

Single System – Single Mains

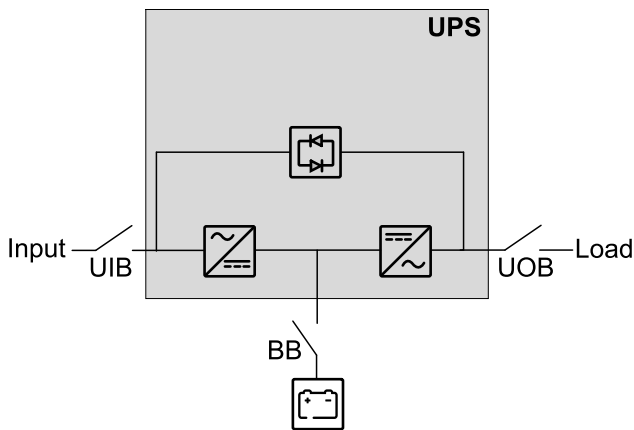

Single System – Dual Mains

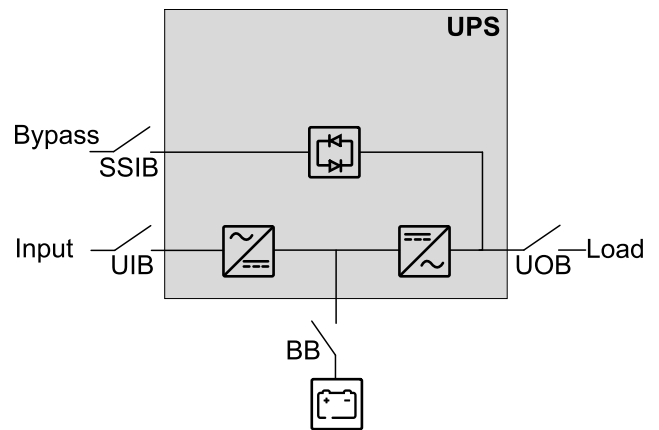

Parallel System Overview

UIB	Unit input breaker
SSIB	Static switch input breaker
UOB	Unit output breaker
SIB	System isolation breaker
BB	Battery breaker
MBB	External maintenance bypass breaker

Galaxy VL can support up to 6 UPSs in parallel for capacity and up to 5+1 UPSs in parallel for redundancy with individual unit input breaker UIB and static switch input breaker SSIB.

Parallel System – Single Mains

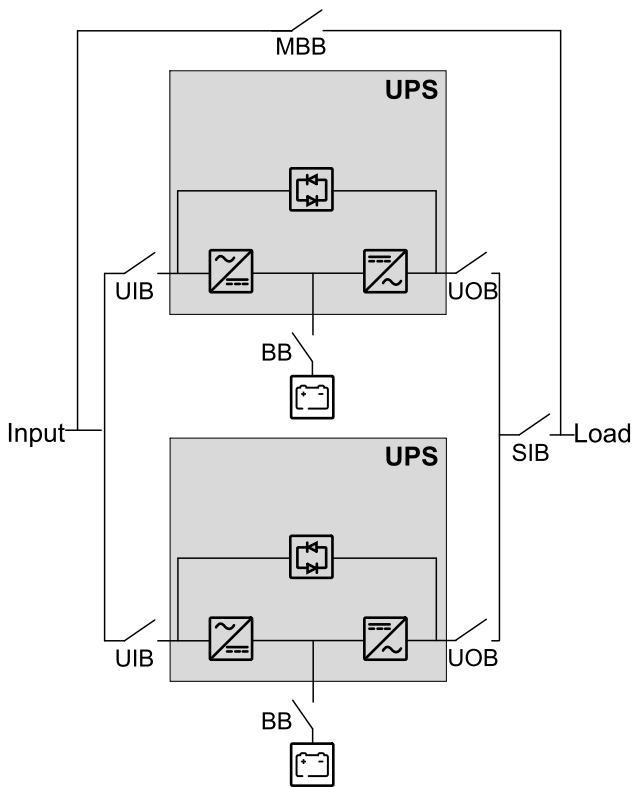

Parallel System – Dual Mains

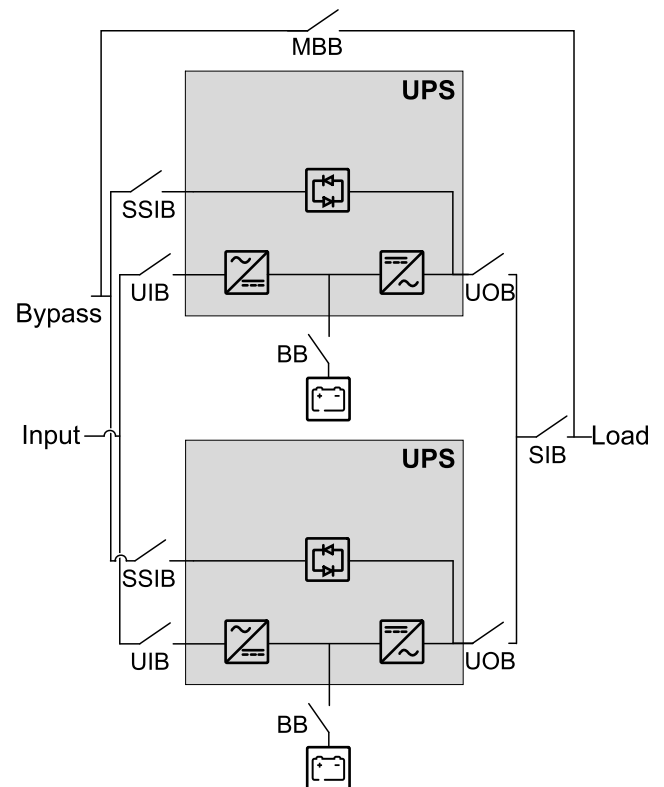

Input Voltage Window

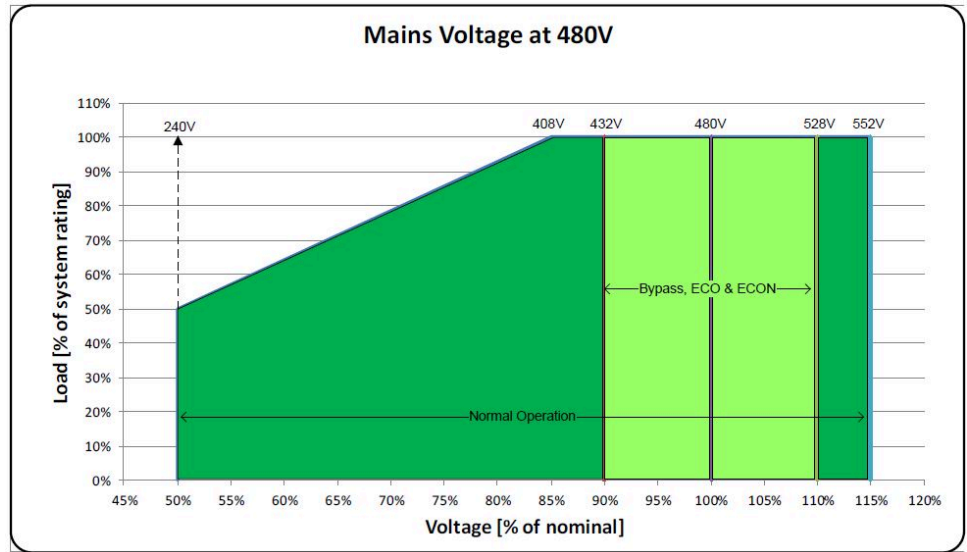

Inverter Short Circuit Capabilities (Bypass not Available)

IK1 – Short Circuit between a Phase and Neutral

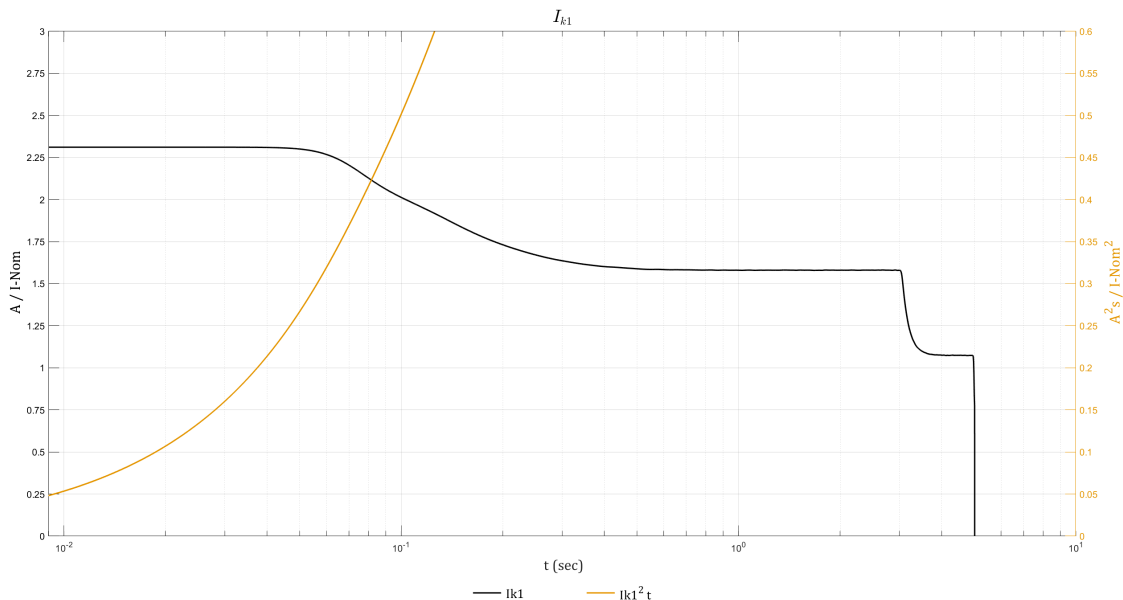

IK1 480 V

S [kVA]	10ms; I[A]/I ² t [A ² t]	20ms; I[A]/I ² t [A ² t]	30ms; I[A]/I ² t [A ² t]	100ms; I[A]/I ² t [A ² t]	1s; I[A]/I ² t [A ² t]
200	560 /3090	560 /6180	560 /9280	480 /29020	380 /167430
250	700 /4830	700 /9660	700 /14490	610 /45350	480 /261610
300	830 /6960	830 /13910	830 /20870	730 /65300	570 /376720
350	970 /9470	970 /18940	970 /28410	850 /88880	670 /512750
400	1110 /12370	1110 /24740	1110 /37100	970 /116090	760 /669720
450	1250 /15650	1250 /31310	1250 /46960	1090 /146930	860 /847610
500	1390 /19330	1390 /38650	1390 /57970	1210 /181390	950 /1046430

IK2 – Short Circuit between Two Phases

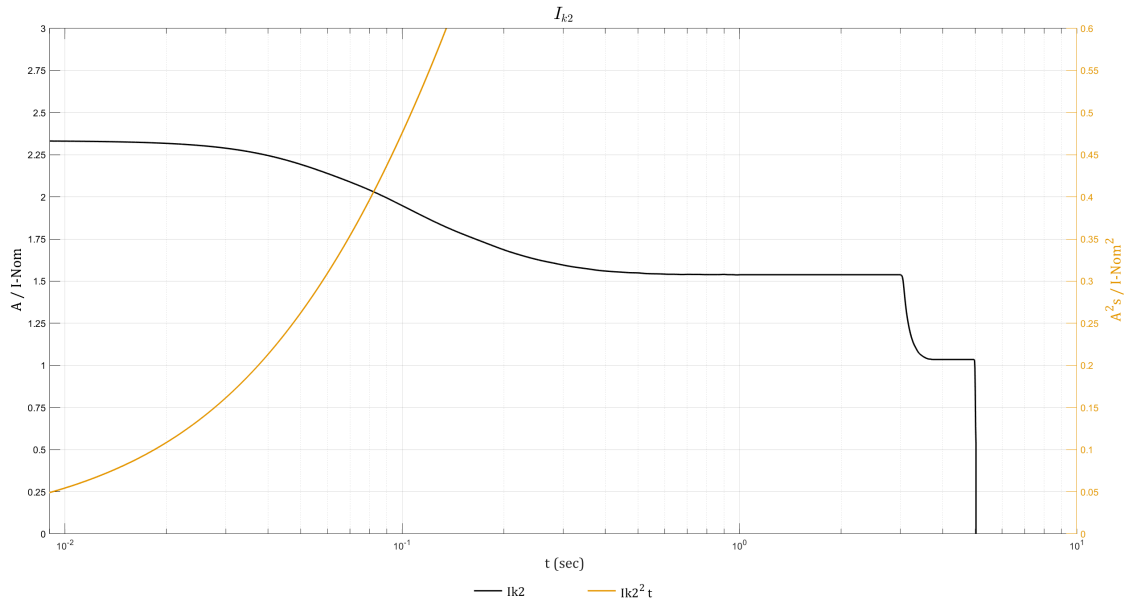

IK2 480 V

S [kVA]	10ms; I[A]/I ² t [A ² t]	20ms; I[A]/I ² t [A ² t]	30ms; I[A]/I ² t [A ² t]	100ms; I[A]/I ² t [A ² t]	1s; I[A]/I ² t [A ² t]
200	560 /3150	560 /6280	560 /9350	470 /27550	370 /158630
250	700 /4920	700 /9810	700 /14610	590 /43050	460 /247850
300	840 /7090	840 /14130	840 /21040	700 /61990	550 /356910
350	980 /9640	980 /19230	980 /28640	820 /84380	650 /485790
400	1120 /12600	1120 /25110	1120 /37410	940 /110210	740 /634500
450	1260 /15940	1250 /31790	1250 /47350	1050 /139480	830 /803040
500	1400 /19680	1390 /39240	1390 /58450	1170 /172200	920 /991410

IK3 – Short Circuit between Three Phases

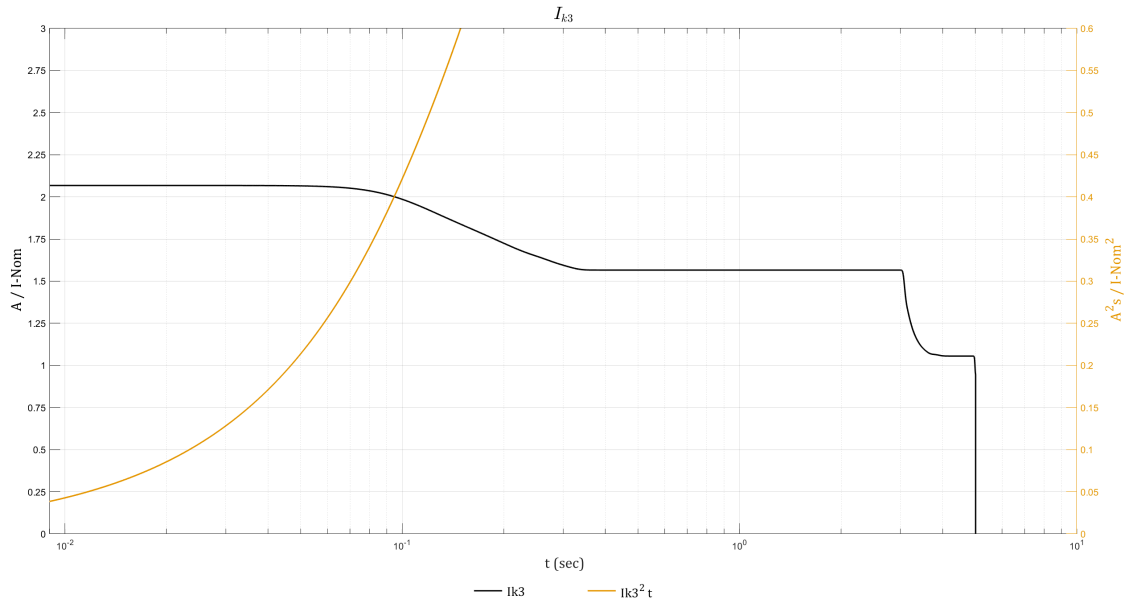

IK3 480 V

S [kVA]	10ms; I[A]/I²t [A²t]	20ms; I[A]/I²t [A²t]	30ms; I[A]/I²t [A²t]	100ms; I[A]/I²t [A²t]	1s; I[A]/I²t [A²t]
200	500 /2470	500 /4950	500 /7420	480 /24390	380 /159310
250	620 /3870	620 /7730	620 /11600	600 /38110	470 /248920
300	750 /5570	750 /11140	750 /16700	720 /54880	570 /358450
350	870 /7580	870 /15160	870 /22740	840 /74690	660 /487890
400	990 /9900	990 /19800	990 /29700	960 /97560	750 /637240
450	1120 /12530	1120 /25060	1120 /37580	1070 /123470	850 /806510
500	1240 /15470	1240 /30930	1240 /46400	1190 /152440	940 /995690

Efficiency for 480 V

200 kW	Normal operation	ECO mode	eConversion	Battery operation
Voltage (V)	480			
25% load	96.3%	98.9%	98.1%	95.5%
50% load	97.2%	99.3%	98.9%	96.3%
75% load	97.3%	99.4%	99.2%	96.5%
100% load	97.2%	99.5%	99.3%	96.4%

250 kW	Normal operation	ECO mode	eConversion	Battery operation
Voltage (V)	480			
25% load	96.4%	99.0%	98.1%	95.7%
50% load	97.2%	99.3%	98.9%	96.4%
75% load	97.3%	99.4%	99.2%	96.5%
100% load	97.2%	99.5%	99.3%	96.4%

300 kW	Normal operation	ECO mode	eConversion	Battery operation
Voltage (V)	480			
25% load	96.4%	99.0%	98.1%	95.8%
50% load	97.2%	99.3%	98.9%	96.4%
75% load	97.3%	99.4%	99.2%	96.5%
100% load	97.2%	99.5%	99.3%	96.4%

350 kW	Normal operation	ECO mode	eConversion	Battery operation
Voltage (V)	480			
25% load	96.4%	99.1%	98.2%	95.9%
50% load	97.1%	99.4%	98.9%	96.5%
75% load	97.3%	99.5%	99.2%	96.5%
100% load	97.2%	99.5%	99.3%	96.4%

400 kW	Normal operation	ECO mode	eConversion	Battery operation
Voltage (V)	480			
25% load	96.4%	99.1%	98.2%	95.9%
50% load	97.1%	99.4%	98.9%	96.5%
75% load	97.3%	99.5%	99.2%	96.5%
100% load	97.2%	99.5%	99.3%	96.4%

450 kW	Normal operation	ECO mode	eConversion	Battery operation
Voltage (V)	480			
25% load	96.4%	99.1%	98.2%	96.0%
50% load	97.1%	99.4%	99.0%	96.5%
75% load	97.2%	99.4%	99.2%	96.5%
100% load	97.1%	99.5%	99.3%	96.4%

500 kW	Normal operation	ECO mode	eConversion	Battery operation
Voltage (V)	480			
25% load	96.4%	99.1%	98.2%	96.0%
50% load	97.1%	99.4%	99.0%	96.5%
75% load	97.2%	99.4%	99.2%	96.5%
100% load	97.1%	99.5%	99.3%	96.4%

Derating Due to Load Power Factor

0.5 leading to 0.5 lagging without derating.

UPS rating	UPS output									
	Lagging					Leading				
PF=1	PF=0.5	PF=0.6	PF=0.7	PF=0.8	PF=0.9	PF=0.9	PF=0.8	PF=0.7	PF=0.6	PF=0.5
200 kW/ kVA	200 kVA / 100 kW	200 kVA / 120 kW	200 kVA / 140 kW	200 kVA / 160 kW	200 kVA / 180 kW	200 kVA / 180 kW	200 kVA / 160 kW	200 kVA / 140 kW	200 kVA / 120 kW	200 kVA / 100 kW
250 kW/ kVA	250 kVA / 125 kW	250 kVA / 150 kW	250 kVA / 175 kW	250 kVA / 200 kW	250 kVA / 225 kW	250 kVA / 225 kW	250 kVA / 200 kW	250 kVA / 175 kW	250 kVA / 150 kW	250 kVA / 125 kW
300 kW/ kVA	300 kVA / 150 kW	300 kVA / 180 kW	300 kVA / 210 kW	300 kVA / 240 kW	300 kVA / 270 kW	300 kVA / 270 kW	300 kVA / 240 kW	300 kVA / 210 kW	300 kVA / 180 kW	300 kVA / 150 kW
350 kW/ kVA	350 kVA / 175 kW	350 kVA / 210 kW	350 kVA / 245 kW	350 kVA / 280 kW	350 kVA / 315 kW	350 kVA / 315 kW	350 kVA / 280 kW	350 kVA / 245 kW	350 kVA / 210 kW	350 kVA / 175 kW
400 kW/ kVA	400 kVA / 200 kW	400 kVA / 240 kW	400 kVA / 280 kW	400 kVA / 320 kW	400 kVA / 360 kW	400 kVA / 360 kW	400 kVA / 320 kW	400 kVA / 280 kW	400 kVA / 240 kW	400 kVA / 200 kW
450 kW/ kVA	450 kVA / 225 kW	450 kVA / 270 kW	450 kVA / 315 kW	450 kVA / 360 kW	450 kVA / 405 kW	450 kVA / 405 kW	450 kVA / 360 kW	450 kVA / 315 kW	450 kVA / 270 kW	450 kVA / 225 kW
500 kW/ kVA	500 kVA / 250 kW	500 kVA / 300 kW	500 kVA / 350 kW	500 kVA / 400 kW	500 kVA / 450 kW	500 kVA / 450 kW	500 kVA / 400 kW	500 kVA / 350 kW	500 kVA / 300 kW	500 kVA / 250 kW

Batteries

Common Battery

For parallel UPS systems, simplified common battery configuration (VRLA/Lithium-ion) is supported.

End of Discharge Voltage

The voltage is 1.6 to 1.75 per cell depending on discharge ratio.

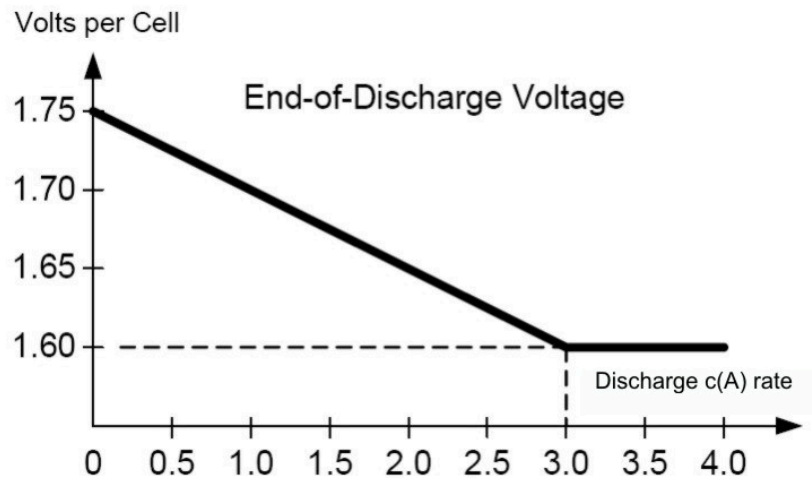

Standard VRLA Voltage Levels

Standard VRLA Voltage Levels
(at nominal temperature)

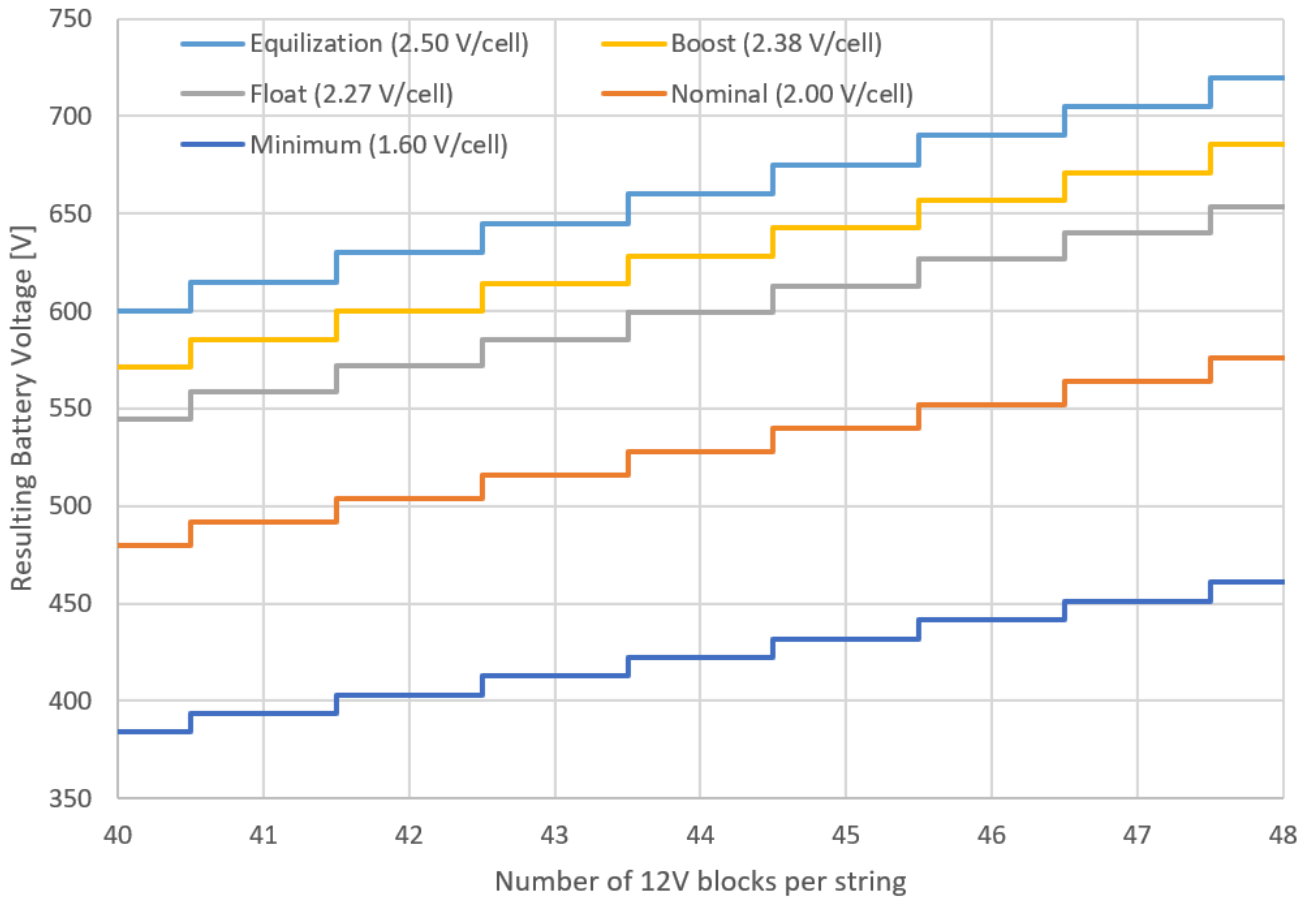

NOTE: Specific configurations may differ from the general constraint shown above.

Compliance

Safety	IEC 62040-1: 2017, Edition 2.0, Uninterruptible Power Systems (UPS) - Part 1: Safety requirements UL 1778 5th edition
EMC/EMI/RFI	IEC 62040-2: 2016-11, 3rd edition Uninterruptible Power Systems (UPS) - Part 2: Electromagnetic compatibility (EMC) requirements C2 FCC Part 15 Subpart B, Class A
Performance	Performance in accordance with: IEC 62040-3: 2021-04, 3rd edition Uninterruptible Power Systems (UPS) - Part 3: Method of specifying the performance and test requirements.
Transportation	IEC 60721-4-2 Level 2M2
Seismic	ICC-ES AC 156 (2015); OSHPD Pre-approved; Sds=1.45 g for z/h=1 and Sds=2.00 g for z/h=0; Ip=1.5
Earthing system ¹	Solid-grounded, HRG
Overvoltage category	This UPS is OVCII compliant. If the UPS is installed in an environment with an OVC rating higher than II, an SPD (surge protection device) must be installed upstream of the UPS to reduce the overvoltage category to OVCII.
Protective class	I
Pollution degree	2

Regional Seismic Compliance

Certificate available upon request.

Country/Region	Code ID	Hazard level ground	Hazard level roof
Argentina	INPRES-CIRSOC103	Zone 4	Zone 4
Australia	AS 1170.4-2007	Z = 0.22	Z = 0.22
Canada ²	2020 NBCC	S _a = 1.95	S _a = 1.44
Chile	NCh 433.Of1996	Zone 3	Zone 2
China	GB 50011-2010 (2016)	α _{Max} = 1.4	α _{Max} = 0.9
Europe	Eurocode 8 EN1998-1	α _{gR} = 0.375	α _{gR} = 0.25
India	IS 1893 (Part 1) : 2016	Z = 0.36	Z = 0.36
Japan	Building Standard Law	Zone A	Zone A
New Zealand	NZS 1170.5:2004+A1	Z = 0.54	Z = 0.37
Peru	N.T.E. - E.030	Zone 4	Zone 4
Russia	SNIP II-7-81 (SP 14.13330.2014)	MSK 9	MSK 9
Taiwan	CPA 2011 Seismic Design Code	S _s ^D = 0.8	S _s ^D = 0.8
U.S.A. ²	ASCE 7-16 / IBC 2018	S _{DS} = 1.98	S _{DS} = 1.45

1. Corner grounding not permitted.
2. OSHPD Pre-approved in accordance with AC156 test protocol.

Communication and Management

Local area network	1 Gbps – 1 port as default
Modbus	Modbus (SCADA)
Output relays	4 x SELV configurable
Input contacts	4 x SELV configurable
Standard control panel	7 inch touchscreen display
Audible alarm	Yes
Emergency Power Off (EPO)	Options: <ul style="list-style-type: none"> • Normally Open (NO) • Normally Closed (NC) • External 24 VDC SELV
External switchgear	UIB UOB SSIB MBB SIB
External synchronization	Yes
Battery monitoring	Available for external battery solutions

EPO

EPO Configurations (Terminal J6600, 1-9)

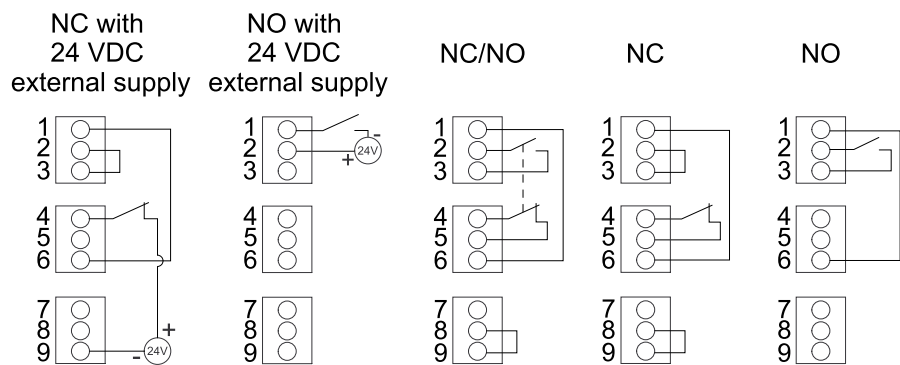

The EPO input supports 24 VDC.

NOTE: The default setting for the EPO activation is to turn off the inverter.

If you want the EPO activation to transfer the UPS into forced static bypass operation instead, please contact Schneider Electric.

Configurable Input Contacts and Output Relays

Input Contacts

Four input contacts are available and can be configured to indicate a given event via the display.

The input contacts support 24 VDC 10 mA. All circuits connected must have the same 0 V reference.

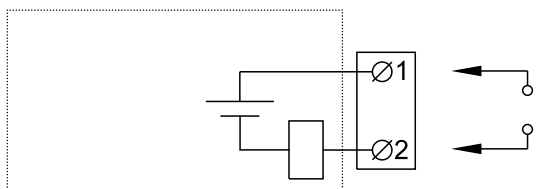

Name	Description	Location
IN_1 (input contact 1)	Configurable input contact	Terminal J6616, 1-2
IN_2 (input contact 2)		Terminal J6616, 3-4
IN_3 (input contact 3)		Terminal J6616, 5-6
IN_4 (input contact 4)		Terminal J6616, 7-8

Output Relays

Four output relays are available and can be configured to activate on one or more events via the display.

The output relays support 24 VAC/VDC 1 A. All external circuitry must be fused with maximum 1 A fast acting fuses.

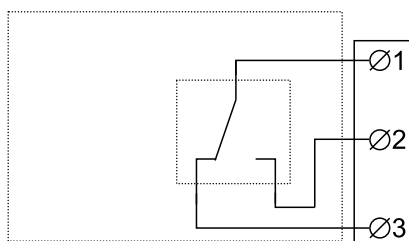

Name	Description	Location
OUT_1 (output relay 1)	Configurable output relay	Terminal J6617, 1-3
OUT_2 (output relay 2)		Terminal J6617, 4-6
OUT_3 (output relay 3)		Terminal J6617, 7-9
OUT_4 (output relay 4)		Terminal J6617, 10-12

When **Energized check mode** is enabled, the output relay is activated, and will deactivate when the events assigned to the output relay occurs (normally activated).

Energized check mode must be individually enabled for each output relay and makes it possible to detect if the output relay is inoperable:

- If the power supply to the output relays is lost, the events assigned to all the output relays will be indicated as present.
- If a single output relay has become inoperable, the events assigned to the single output relay will be indicated as present.

Requirements for a Third Party Battery Solution

Battery breaker boxes from Schneider Electric are recommended for the battery interface. Please contact Schneider Electric for more information.

Third Party Battery Breaker Requirements



HAZARD OF ELECTRIC SHOCK, EXPLOSION, OR ARC FLASH

- All selected battery breakers must be equipped with instantaneous trip functionality with an undervoltage release coil or a shunt trip release coil.
- Trip delay must be set to zero on all battery breakers.

Failure to follow these instructions will result in death or serious injury.

NOTE: There are more factors to consider when selecting a battery breaker than the requirements listed below. Please contact Schneider Electric for more information.

Design Requirements for Battery Breaker

Battery breaker rated DC voltage > Normal battery voltage	The normal voltage of the battery configuration is defined as the highest nominal occurring battery voltage. This can be equivalent to the float voltage which may be defined as number of battery blocks x number of cells x cell float voltage .
Battery breaker rated DC current > Rated discharge battery current	This current is controlled by the UPS and must include maximum discharge current. This will typically be the current at the end of discharge (minimum operation DC voltage or in overload condition or a combination).
DC landings	Two DC landings for DC cables (DC+ and DC-) are required.
AUX switches for monitoring	One AUX switch must be installed in each battery breaker and connected to the UPS. The UPS can monitor up to four battery breakers.
Short-circuit breaking capability	The short-circuit breaking capability must be higher than the short-circuit DC current of the (largest) battery configuration.
Minimum trip current	The minimum short-circuit current to trip the battery breaker must match the (smallest) battery configuration, to make the breaker trip in case of a short circuit, up to the end of its life time.
Common battery solution	Individual battery breaker for each UPS in the parallel system.

Guidance for Organizing Battery Cables

NOTE: For 3rd party batteries, use only high rate batteries for UPS applications.

NOTE: When the battery bank is placed remotely, the organizing of the cables is important to reduce voltage drop and inductance. The distance between the battery bank and the UPS must not exceed 200 m (656 ft). Contact Schneider Electric for installations with a longer distance.

NOTE: To minimize the risk of electromagnetic radiation, it is highly recommended to follow the below guidance and to use grounded metallic tray supports.

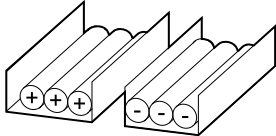
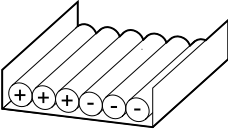
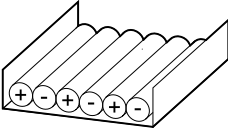
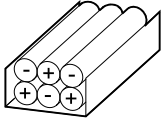
Cable Length				
<30 m	Not recommended	Acceptable	Recommended	Recommended
31–75 m	Not recommended	Not recommended	Acceptable	Recommended
76–150 m	Not recommended	Not recommended	Acceptable	Recommended
151–200 m	Not recommended	Not recommended	Not recommended	Recommended

Specifications

Specifications for 200 kW UPS

	Voltage (V)	380	400	415	440	480
Input	Connections	Single mains: 4-wire (L1, L2, L3, N, PE) or 3-wire (L1, L2, L3, PE) Dual mains: 3-wire (L1, L2, L3, PE)				Single mains: 4-wire ³ (L1, L2, L3, N, G) or 3-wire ³ (L1, L2, L3, G) Dual mains: 3-wire ³ (L1, L2, L3, G)
	Input voltage range (V)	331-437	340-460	353-477	374-506	408-552
	Frequency (Hz)	40-70				
	Nominal input current (A)	316	299	288	272	249
	Minimum short circuit rating	Dependent on upstream protection. See section for Recommended upstream protection for IEC for details.				–
	Maximum short circuit rating	65 kA l _{cw} 25 kA l _{cw} with maintenance bypass cabinet (GVLBCA200K500H) 45 kA l _{cw} with bottom entry cabinet (GVBECC) 65 kA l _{cw} with bottom entry cabinet (GVBECC and GVLOPT012 installed) 65 kA l _{cc} with backfeed breaker kit (GVLOPT004) installed in the UPS ⁴				–
	Maximum input current (A)	371	365	352	332	303
	Input current limitation (A)	371	370	366	342	313
	Total harmonic distortion (THDI)	<3% at 100% load				
	Input power factor	>0.99 at load >25%, 0.95 at >15% load				
	Protection	Built-in backfeed protection and fuses				
	Ramp-in	Adaptive 1-300 seconds				

3. WYE source – solid grounded and high resistance grounded sources are supported. Corner (line) grounding is not permitted.
4. Refer to the physical short circuit rating label on the UPS for the exact short circuit rating options of the specific UPS.

	Voltage (V)	380	400	415	440	480
Bypass	Connections	4-wire (L1, L2, L3, N, PE) or 3-wire (L1, L2, L3, PE)				4-wire (L1, L2, L3, N, G) or 3-wire (L1, L2, L3, G)
	Bypass voltage range (V)	342-418	360-440	374-457	396-484	432-528
	Frequency (Hz)	50 or 60				
	Frequency range (Hz)	Programmable: ±1, ±3, ±10. Default is ±3.				
	Nominal bypass current (A)	312	297	286	270	247
	Minimum short circuit rating	Dependent on upstream protection. See section for Recommended upstream protection for IEC for details.				–
	Maximum short circuit rating (three cycles)	65 kA l _{cw} 25 kA l _{cw} with maintenance bypass cabinet (GVLMBCA200K500H) 45 kA l _{cw} with bottom entry cabinet (GVBEC) 65 kA l _{cw} with bottom entry cabinet (GVBEC and GVLOPT012 installed) 65 kA l _{cc} with backfeed breaker kit (GVLOPT004) installed in the UPS ⁵				65 kAIC 65 kAIC with maintenance bypass cabinet (GVLMBCA200K500-G) 45 kAIC l _{cw} with bottom entry cabinet (GVBEC) 65 kAIC l _{cw} with bottom entry cabinet (GVBEC and GVLOPT012 installed) 65 kAIC with backfeed breaker kit (GVLOPT003) installed in the UPS ⁵
	I ² t thyristor value (A ² s)	3.1 MA ² s				
	Bypass backfeed protection options	1: Upstream installation of breaker with shunt trip connected to the UPS, OR 2: Installation with maintenance bypass cabinet (GVLMBCA200K500H / GVLMBCA200K500G), OR 3: Installation of backfeed breaker kit (GVLOPT004 / GVLOPT003) in the UPS.				

5. Refer to the physical short circuit rating label on the UPS for the exact short circuit rating options of the specific UPS.

	Voltage (V)	380	400	415	440	480
Output	Connections ⁶	4-wire (L1, L2, L3, N, PE) or 3-wire (L1, L2, L3, PE)				4-wire (L1, L2, L3, N, G) or 3-wire (L1, L2, L3, G, GEC ⁷)
	Output voltage regulation	Symmetrical load $\pm 1\%$ Asymmetrical load $\pm 3\%$				
	Overload capacity	Normal operation: 150% for 1 minute, 125% for 10 minutes, (110% continuous ⁸) Battery operation: 125% for 1 minute Bypass operation: 110% continuous, 1600% for 100 milliseconds				Normal operation: 150% for 1 minute, 125% for 10 minutes, (110% continuous ⁸) Battery operation: 125% for 1 minute Bypass operation: 125% continuous, 1600% for 100 milliseconds
	Dynamic load response	$\pm 5\%$ after 2 ms, $\pm 1\%$ after 50 ms				
	Output power factor	1				
	Nominal output current (A)	304	289	278	262	241
	Minimum short circuit rating ⁹	Dependent on upstream protection. See section for Recommended upstream protection for IEC for details.				–
	Maximum short circuit rating ¹⁰	65 kA lcw 25 kA lcw with maintenance bypass cabinet GVLMBCA200K500H 45 kA lcw with bottom entry cabinet (GVBECC) 65 kA lcw with bottom entry cabinet (GVBECC and GVLOPT012 installed) 65 kA lcc with backfeed breaker kit GVLOPT004 installed in the UPS ¹¹				–
	Inverter output short circuit capabilities	Varies with time. See graph and table values in Inverter Short Circuit Capabilities (Bypass not Available), page 15.				
	Output frequency (Hz)	50/60 (synchronized to bypass), 50/60 Hz $\pm 0.1\%$ (free-running)				
	Synchronized slew rate (Hz/sec)	Programmable: 0.25, 0.5, 1, 2, 4, 6				
	Total harmonic distortion (THDU)	<1% for linear load, <5% for non-linear load				
	Output performance classification (according to IEC/ EN62040-3)	VFI-SS-11				
	Load crest factor	3				
	Load power factor	0.5 leading to 0.5 lagging without derating				

6. The number of output connections must match the number of input connections in a single mains system or the number of bypass connections in a dual mains system.

7. Per NEC 250.30.

8. 110% continuous overload in normal operation at nominal mains voltage and at maximum 40 °C (104 °F) ambient temperature. Contact Schneider Electric to enable this function.

9. Minimum short circuit rating for output takes backfeeding energy through the bypass of parallel UPSs into consideration.

10. Maximum short circuit rating for output takes backfeeding energy through the bypass of parallel UPSs into consideration.

11. Refer to the physical short circuit rating label on the UPS for the exact short circuit rating options of the specific UPS.

	Voltage (V)	380	400	415	440	480
Battery	Charging power in % of output power	0-40% load: 80% 100% load: 15%	0-40% load: 80% 100% load: 20%			
	Maximum charging power (kW)	0-40% load: 160 100% load: 30	0-40% load: 160 100% load: 40			
	Nominal battery voltage (VDC)	480 for 40 blocks 576 for 48 blocks				
	Nominal float voltage (VDC)	545 for 40 blocks 654 for 48 blocks				
	Maximum boost voltage (VDC)	571 for 40 blocks 685 for 48 blocks				
	Temperature compensation (per cell)	-3.3mV/°C for T ≥ 25 °C, 0mV/°C for T < 25 °C				
	End of discharge voltage (full load) (VDC)	384				
	End of discharge voltage (no load) (VDC)	420				
	Battery current at full load and nominal battery voltage (A)	434				
	Battery current at full load and minimum battery voltage (A)	543				
	Ripple current	< 5% C20 (5 minute runtime)				
	Battery test	Manual/automatic (selectable)				
	Maximum short circuit rating	30 kA				

NOTE: Battery specifications are based on VRLA batteries.

Specifications for 250 kW UPS

	Voltage (V)	380	400	415	440	480
Input	Connections	Single mains: 4-wire (L1, L2, L3, N, PE) or 3-wire (L1, L2, L3, PE) Dual mains: 3-wire (L1, L2, L3, PE)				Single mains: 4-wire ¹² (L1, L2, L3, N, G) or 3-wire ¹² (L1, L2, L3, G) Dual mains: 3-wire ¹² (L1, L2, L3, G)
	Input voltage range (V)	331-437	340-460	353-477	374-506	408-552
	Frequency (Hz)	40-70				
	Nominal input current (A)	395	374	360	340	311
	Minimum short circuit rating	Dependent on upstream protection. See section for Recommended upstream protection for IEC for details.				–
	Maximum short circuit rating (three cycles)	65 kA l _{cw} 25 kA l _{cw} with maintenance bypass cabinet (GVLBCA200K500H) 45 kA l _{cw} with bottom entry cabinet (GVBECC) 65 kA l _{cw} with bottom entry cabinet (GVBECC and GVLOPT012 installed) 65 kA l _{cc} with backfeed breaker kit (GVLOPT004) installed in the UPS ¹³				–
	Maximum input current (A)	463	457	440	415	379
	Input current limitation (A)	463	463	458	427	392
	Total harmonic distortion (THDI)	<3% at 100% load				
	Input power factor	>0.99 at load >25%, 0.95 at >15% load				
	Protection	Built-in backfeed protection and fuses				
	Ramp-in	Adaptive 1-300 seconds				

12. WYE source – solid grounded and high resistance grounded sources are supported. Corner (line) grounding is not permitted.

13. Refer to the physical short circuit rating label on the UPS for the exact short circuit rating options of the specific UPS.

	Voltage (V)	380	400	415	440	480
Bypass	Connections	4-wire (L1, L2, L3, N, PE) or 3-wire (L1, L2, L3, PE)				4-wire (L1, L2, L3, N, G) or 3-wire (L1, L2, L3, G)
	Bypass voltage range (V)	342-418	360-440	374-457	396-484	432-528
	Frequency (Hz)	50 or 60				
	Frequency range (Hz)	Programmable: ±1, ±3, ±10. Default is ±3.				
	Nominal bypass current (A)	390	371	357	337	309
	Minimum short circuit rating	Dependent on upstream protection. See section for Recommended upstream protection for IEC for details.				–
	Maximum short circuit rating (three cycles)	65 kA l _{cw} 25 kA l _{cw} with maintenance bypass cabinet (GVLMBCA200K500H) 45 kA l _{cw} with bottom entry cabinet (GVBEC) 65 kA l _{cw} with bottom entry cabinet (GVBEC and GVLOPT012 installed) 65 kA l _{cc} with backfeed breaker kit (GVLOPT004) installed in the UPS ¹⁴				65 kAIC 65 kAIC with maintenance bypass cabinet (GVLMBCA200K500-G) 45 kAIC l _{cw} with bottom entry cabinet (GVBEC) 65 kAIC l _{cw} with bottom entry cabinet (GVBEC and GVLOPT012 installed) 65 kAIC with backfeed breaker kit (GVLOPT003) installed in the UPS ¹⁴
	I ² t thyristor value (A ² s)	3.1 MA ² s				
	Bypass backfeed protection options	1: Upstream installation of breaker with shunt trip connected to the UPS, OR 2: Installation with maintenance bypass cabinet (GVLMBCA200K500H / GVLMBCA200K500G), OR 3: Installation of backfeed breaker kit (GVLOPT004 / GVLOPT003) in the UPS.				

14. Refer to the physical short circuit rating label on the UPS for the exact short circuit rating options of the specific UPS.

Voltage (V)		380	400	415	440	480
Output	Connections ¹⁵	4-wire (L1, L2, L3, N, PE) or 3-wire (L1, L2, L3, PE)				4-wire (L1, L2, L3, N, G) or 3-wire (L1, L2, L3, G, GEC ¹⁶)
	Output voltage regulation	Symmetrical load ± 1% Asymmetrical load ± 3%				
	Overload capacity	Normal operation: 150% for 1 minute, 125% for 10 minutes, (110% continuous ¹⁷) Battery operation: 125% for 1 minute Bypass operation: 110% continuous, 1600% for 100 milliseconds				Normal operation: 150% for 1 minute, 125% for 10 minutes, (110% continuous ¹⁷) Battery operation: 125% for 1 minute Bypass operation: 125% continuous, 1600% for 100 milliseconds
	Dynamic load response	± 5% after 2 ms, ± 1% after 50 ms				
	Output power factor	1				
	Nominal output current (A)	380	361	348	328	301
	Minimum short circuit rating ¹⁸	Dependent on upstream protection. See section for Recommended upstream protection for IEC for details.				–
	Maximum short circuit rating ¹⁹	65 kA lcw 25 kA lcw with maintenance bypass cabinet GVLMBCA200K500H 45 kA lcw with bottom entry cabinet (GVBECC) 65 kA lcw with bottom entry cabinet (GVBECC and GVLOPT012 installed) 65 kA lcc with backfeed breaker kit GVLOPT004 installed in the UPS ²⁰				–
	Inverter output short circuit capabilities	Varies with time. See graph and table values in Inverter Short Circuit Capabilities (Bypass not Available), page 15.				
	Output frequency (Hz)	50/60 (synchronized to bypass), 50/60 Hz ±0.1% (free-running)				
	Synchronized slew rate (Hz/sec)	Programmable: 0.25, 0.5, 1, 2, 4, 6				
	Total harmonic distortion (THDU)	<1% for linear load, <5% for non-linear load				
	Output performance classification (according to IEC/ EN62040-3)	VFI-SS-11				
	Load crest factor	3				
	Load power factor	0.5 leading to 0.5 lagging without derating				

15. The number of output connections must match the number of input connections in a single mains system or the number of bypass connections in a dual mains system.

16. Per NEC 250.30.

17. 110% continuous overload in normal operation at nominal mains voltage and at maximum 40 °C (104 °F) ambient temperature. Contact Schneider Electric to enable this function.

18. Minimum short circuit rating for output takes backfeeding energy through the bypass of parallel UPSs into consideration.

19. Maximum short circuit rating for output takes backfeeding energy through the bypass of parallel UPSs into consideration.

20. Refer to the physical short circuit rating label on the UPS for the exact short circuit rating options of the specific UPS.

	Voltage (V)	380	400	415	440	480
Battery	Charging power in % of output power	0-40% load: 80% 100% load: 15%	0-40% load: 80% 100% load: 20%			
	Maximum charging power (kW)	0-40% load: 200 100% load: 37.5	0-40% load: 200 100% load: 50			
	Nominal battery voltage (VDC)	480 for 40 blocks 576 for 48 blocks				
	Nominal float voltage (VDC)	545 for 40 blocks 654 for 48 blocks				
	Maximum boost voltage (VDC)	571 for 40 blocks 685 for 48 blocks				
	Temperature compensation (per cell)	-3.3mV/°C for T ≥ 25 °C, 0mV/°C for T < 25 °C				
	End of discharge voltage (full load) (VDC)	384				
	End of discharge voltage (no load) (VDC)	420				
	Battery current at full load and nominal battery voltage (A)	543				
	Battery current at full load and minimum battery voltage (A)	678				
	Ripple current	< 5% C20 (5 minute runtime)				
	Battery test	Manual/automatic (selectable)				
	Maximum short circuit rating	30 kA				

NOTE: Battery specifications are based on VRLA batteries.

Specifications for 300 kW UPS

	Voltage (V)	380	400	415	440	480
Input	Connections	Single mains: 4-wire (L1, L2, L3, N, PE) or 3-wire (L1, L2, L3, PE) Dual mains: 3-wire (L1, L2, L3, PE)				Single mains: 4-wire ²¹ (L1, L2, L3, N, G) or 3-wire ²¹ (L1, L2, L3, G) Dual mains: 3-wire ²¹ (L1, L2, L3, G)
	Input voltage range (V)	331-437	340-460	353-477	374-506	408-552
	Frequency (Hz)	40-70				
	Nominal input current (A)	474	449	432	408	373
	Minimum short circuit rating	Dependent on upstream protection. See section for Recommended upstream protection for IEC for details.				–
	Maximum short circuit rating (three cycles)	65 kA l _{cw} 25 kA l _{cw} with maintenance bypass cabinet (GVLMBCA200K500H) 45 kA l _{cw} with bottom entry cabinet (GVBECC) 65 kA l _{cw} with bottom entry cabinet (GVBECC and GVLOPT012 installed) 65 kA l _{cc} with backfeed breaker kit (GVLOPT004) installed in the UPS ²²				–
	Maximum input current (A)	555	548	528	498	455
	Input current limitation (A)	555	555	549	513	470
	Total harmonic distortion (THDI)	<3% at 100% load				
	Input power factor	>0.99 at load >25%, 0.95 at >15% load				
	Protection	Built-in backfeed protection and fuses				
	Ramp-in	Adaptive 1-300 seconds				

21. WYE source – solid grounded and high resistance grounded sources are supported. Corner (line) grounding is not permitted.

22. Refer to the physical short circuit rating label on the UPS for the exact short circuit rating options of the specific UPS.

	Voltage (V)	380	400	415	440	480
Bypass	Connections	4-wire (L1, L2, L3, N, PE) or 3-wire (L1, L2, L3, PE)				4-wire (L1, L2, L3, N, G) or 3-wire (L1, L2, L3, G)
	Bypass voltage range (V)	342-418	360-440	374-457	396-484	432-528
	Frequency (Hz)	50 or 60				
	Frequency range (Hz)	Programmable: ±1, ±3, ±10. Default is ±3.				
	Nominal bypass current (A)	468	445	429	404	371
	Minimum short circuit rating	Dependent on upstream protection. See section for Recommended upstream protection for IEC for details.				–
	Maximum short circuit rating (three cycles)	65 kA l _{cw} 25 kA l _{cw} with maintenance bypass cabinet (GVLMBCA200K500H) 45 kA l _{cw} with bottom entry cabinet (GVBEC) 65 kA l _{cw} with bottom entry cabinet (GVBEC and GVLOPT012 installed) 65 kA l _{cc} with backfeed breaker kit (GVLOPT004) installed in the UPS ²³				65 kAIC 65 kAIC with maintenance bypass cabinet (GVLMBCA200K500-G) 45 kAIC l _{cw} with bottom entry cabinet (GVBEC) 65 kAIC l _{cw} with bottom entry cabinet (GVBEC and GVLOPT012 installed) 65 kAIC with backfeed breaker kit (GVLOPT003) installed in the UPS ²³
	I ² t thyristor value (A ² s)	3.1 MA ² s				
	Bypass backfeed protection options	1: Upstream installation of breaker with shunt trip connected to the UPS, OR 2: Installation with maintenance bypass cabinet (GVLMBCA200K500H / GVLMBCA200K500G), OR 3: Installation of backfeed breaker kit (GVLOPT004 / GVLOPT003) in the UPS.				

23. Refer to the physical short circuit rating label on the UPS for the exact short circuit rating options of the specific UPS.

	Voltage (V)	380	400	415	440	480
Output	Connections ²⁴	4-wire (L1, L2, L3, N, PE) or 3-wire (L1, L2, L3, PE)				4-wire (L1, L2, L3, N, G) or 3-wire (L1, L2, L3, G, GEC ²⁵)
	Output voltage regulation	Symmetrical load ± 1% Asymmetrical load ± 3%				
	Overload capacity	Normal operation: 150% for 1 minute, 125% for 10 minutes, (110% continuous ²⁶) Battery operation: 125% for 1 minute Bypass operation: 110% continuous, 1600% for 100 milliseconds				Normal operation: 150% for 1 minute, 125% for 10 minutes, (110% continuous ²⁶) Battery operation: 125% for 1 minute Bypass operation: 125% continuous, 1600% for 100 milliseconds
	Dynamic load response	± 5% after 2 ms, ± 1% after 50 ms				
	Output power factor	1				
	Nominal output current (A)	456	433	417	394	361
	Minimum short circuit rating ²⁷	Dependent on upstream protection. See section for Recommended upstream protection for IEC for details.				–
	Maximum short circuit rating ²⁸	65 kA lcw 25 kA lcw with maintenance bypass cabinet GVLMBCA200K500H 45 kA lcw with bottom entry cabinet (GVBECC) 65 kA lcw with bottom entry cabinet (GVBECC and GVLOPT012 installed) 65 kA lcc with backfeed breaker kit GVLOPT004 installed in the UPS ²⁹				–
	Inverter output short circuit capabilities	Varies with time. See graph and table values in Inverter Short Circuit Capabilities (Bypass not Available), page 15.				
	Output frequency (Hz)	50/60 (synchronized to bypass), 50/60 Hz ±0.1% (free-running)				
	Synchronized slew rate (Hz/sec)	Programmable: 0.25, 0.5, 1, 2, 4, 6				
	Total harmonic distortion (THDU)	<1% for linear load, <5% for non-linear load				
	Output performance classification (according to IEC/ EN62040-3)	VFI-SS-11				
	Load crest factor	3				
	Load power factor	0.5 leading to 0.5 lagging without derating				

24. The number of output connections must match the number of input connections in a single mains system or the number of bypass connections in a dual mains system.

25. Per NEC 250.30.

26. 110% continuous overload in normal operation at nominal mains voltage and at maximum 40 °C (104 °F) ambient temperature. Contact Schneider Electric to enable this function.

27. Minimum short circuit rating for output takes backfeeding energy through the bypass of parallel UPSs into consideration.

28. Maximum short circuit rating for output takes backfeeding energy through the bypass of parallel UPSs into consideration.

29. Refer to the physical short circuit rating label on the UPS for the exact short circuit rating options of the specific UPS.

	Voltage (V)	380	400	415	440	480
Battery	Charging power in % of output power	0-40% load: 80% 100% load: 15%	0-40% load: 80% 100% load: 20%			
	Maximum charging power (kW)	0-40% load: 240 100% load: 45	0-40% load: 240 100% load: 60			
	Nominal battery voltage (VDC)	480 for 40 blocks 576 for 48 blocks				
	Nominal float voltage (VDC)	545 for 40 blocks 654 for 48 blocks				
	Maximum boost voltage (VDC)	571 for 40 blocks 685 for 48 blocks				
	Temperature compensation (per cell)	-3.3mV/°C for T ≥ 25 °C, 0mV/°C for T < 25 °C				
	End of discharge voltage (full load) (VDC)	384				
	End of discharge voltage (no load) (VDC)	420				
	Battery current at full load and nominal battery voltage (A)	651				
	Battery current at full load and minimum battery voltage (A)	814				
	Ripple current	< 5% C20 (5 minute runtime)				
	Battery test	Manual/automatic (selectable)				
	Maximum short circuit rating	30 kA				

NOTE: Battery specifications are based on VRLA batteries.

Specifications for 350 kW UPS

	Voltage (V)	380	400	415	440	480
Input	Connections	Single mains: 4-wire (L1, L2, L3, N, PE) or 3-wire (L1, L2, L3, PE) Dual mains: 3-wire (L1, L2, L3, PE)				Single mains: 4-wire ³⁰ (L1, L2, L3, N, G) or 3-wire ³⁰ (L1, L2, L3, G) Dual mains: 3-wire ³⁰ (L1, L2, L3, G)
	Input voltage range (V)	331-437	340-460	353-477	374-506	408-552
	Frequency (Hz)	40-70				
	Nominal input current (A)	553	524	505	476	435
	Minimum short circuit rating	Dependent on upstream protection. See section for Recommended upstream protection for IEC for details.				–
	Maximum short circuit rating (three cycles)	65 kA l _{cw} 25 kA l _{cw} with maintenance bypass cabinet (GVLBCA200K500H) 45 kA l _{cw} with bottom entry cabinet (GVBECC) 65 kA l _{cw} with bottom entry cabinet (GVBECC and GVLOPT012 installed) 65 kA l _{cc} with backfeed breaker kit (GVLOPT004) installed in the UPS ³¹				–
	Maximum input current (A)	648	640	616	581	531
	Input current limitation (A)	648	648	641	598	548
	Total harmonic distortion (THDI)	<3% at 100% load				
	Input power factor	>0.99 at load >25%, 0.95 at >15% load				
	Protection	Built-in backfeed protection and fuses				
	Ramp-in	Adaptive 1-300 seconds				

30. WYE source – solid grounded and high resistance grounded sources are supported. Corner (line) grounding is not permitted.

31. Refer to the physical short circuit rating label on the UPS for the exact short circuit rating options of the specific UPS.

	Voltage (V)	380	400	415	440	480
Bypass	Connections	4-wire (L1, L2, L3, N, PE) or 3-wire (L1, L2, L3, PE)				4-wire (L1, L2, L3, N, G) or 3-wire (L1, L2, L3, G)
	Bypass voltage range (V)	342-418	360-440	374-457	396-484	432-528
	Frequency (Hz)	50 or 60				
	Frequency range (Hz)	Programmable: ±1, ±3, ±10. Default is ±3.				
	Nominal bypass current (A)	546	519	500	472	432
	Minimum short circuit rating	Dependent on upstream protection. See section for Recommended upstream protection for IEC for details.				–
	Maximum short circuit rating (three cycles)	65 kA l _{cw} 25 kA l _{cw} with maintenance bypass cabinet (GVLMBCA200K500H) 45 kA l _{cw} with bottom entry cabinet (GVBEC) 65 kA l _{cw} with bottom entry cabinet (GVBEC and GVLOPT012 installed) 65 kA l _{cc} with backfeed breaker kit (GVLOPT004) installed in the UPS ³²				65 kAIC 65 kAIC with maintenance bypass cabinet (GVLMBCA200K500-G) 45 kAIC l _{cw} with bottom entry cabinet (GVBEC) 65 kAIC l _{cw} with bottom entry cabinet (GVBEC and GVLOPT012 installed) 65 kAIC with backfeed breaker kit (GVLOPT003) installed in the UPS ³²
	I ² t thyristor value (A ² s)	3.1 MA ² s				
	Bypass backfeed protection options	1: Upstream installation of breaker with shunt trip connected to the UPS, OR 2: Installation with maintenance bypass cabinet (GVLMBCA200K500H / GVLMBCA200K500G), OR 3: Installation of backfeed breaker kit (GVLOPT004 / GVLOPT003) in the UPS.				

32. Refer to the physical short circuit rating label on the UPS for the exact short circuit rating options of the specific UPS.

Voltage (V)		380	400	415	440	480
Output	Connections ³³	4-wire (L1, L2, L3, N, PE) or 3-wire (L1, L2, L3, PE)				4-wire (L1, L2, L3, N, G) or 3-wire (L1, L2, L3, G, GEC ³⁴)
	Output voltage regulation	Symmetrical load ± 1% Asymmetrical load ± 3%				
	Overload capacity	Normal operation: 150% for 1 minute, 125% for 10 minutes, (110% continuous ³⁵) Battery operation: 125% for 1 minute Bypass operation: 110% continuous, 1600% for 100 milliseconds				Normal operation: 150% for 1 minute, 125% for 10 minutes, (110% continuous ³⁵) Battery operation: 125% for 1 minute Bypass operation: 125% continuous, 1600% for 100 milliseconds
	Dynamic load response	± 5% after 2 ms, ± 1% after 50 ms				
	Output power factor	1				
	Nominal output current (A)	532	505	487	459	421
	Minimum short circuit rating ³⁶	Dependent on upstream protection. See section for Recommended upstream protection for IEC for details.				–
	Maximum short circuit rating ³⁷	65 kA l _{cw} 25 kA l _{cw} with maintenance bypass cabinet GVLMBCA200K500H 45 kA l _{cw} with bottom entry cabinet (GVBECC) 65 kA l _{cw} with bottom entry cabinet (GVBECC and GVLOPT012 installed) 65 kA l _{cc} with backfeed breaker kit GVLOPT004 installed in the UPS ³⁸				–
	Inverter output short circuit capabilities	Varies with time. See graph and table values in Inverter Short Circuit Capabilities (Bypass not Available), page 15.				
	Output frequency (Hz)	50/60 (synchronized to bypass), 50/60 Hz ±0.1% (free-running)				
	Synchronized slew rate (Hz/sec)	Programmable: 0.25, 0.5, 1, 2, 4, 6				
	Total harmonic distortion (THDU)	<1% for linear load, <5% for non-linear load				
	Output performance classification (according to IEC/ EN62040-3)	VFI-SS-11				
	Load crest factor	3				
	Load power factor	0.5 leading to 0.5 lagging without derating				

33. The number of output connections must match the number of input connections in a single mains system or the number of bypass connections in a dual mains system.

34. Per NEC 250.30.

35. 110% continuous overload in normal operation at nominal mains voltage and at maximum 40 °C (104 °F) ambient temperature. Contact Schneider Electric to enable this function.

36. Minimum short circuit rating for output takes backfeeding energy through the bypass of parallel UPSs into consideration.

37. Maximum short circuit rating for output takes backfeeding energy through the bypass of parallel UPSs into consideration.

38. Refer to the physical short circuit rating label on the UPS for the exact short circuit rating options of the specific UPS.

	Voltage (V)	380	400	415	440	480
Battery	Charging power in % of output power	0-40% load: 80% 100% load: 15%	0-40% load: 80% 100% load: 20%			
	Maximum charging power (kW)	0-40% load: 280 100% load: 52.5	0-40% load: 280 100% load: 70			
	Nominal battery voltage (VDC)	480 for 40 blocks 576 for 48 blocks				
	Nominal float voltage (VDC)	545 for 40 blocks 654 for 48 blocks				
	Maximum boost voltage (VDC)	571 for 40 blocks 685 for 48 blocks				
	Temperature compensation (per cell)	-3.3mV/°C for T ≥ 25 °C, 0mV/°C for T < 25 °C				
	End of discharge voltage (full load) (VDC)	384				
	End of discharge voltage (no load) (VDC)	420				
	Battery current at full load and nominal battery voltage (A)	760				
	Battery current at full load and minimum battery voltage (A)	949				
	Ripple current	< 5% C20 (5 minute runtime)				
	Battery test	Manual/automatic (selectable)				
	Maximum short circuit rating	30 kA				

NOTE: Battery specifications are based on VRLA batteries.

Specifications for 400 kW UPS

	Voltage (V)	380	400	415	440	480
Input	Connections	Single mains: 4-wire (L1, L2, L3, N, PE) or 3-wire (L1, L2, L3, PE) Dual mains: 3-wire (L1, L2, L3, PE)				Single mains: 4-wire ³⁹ (L1, L2, L3, N, G) or 3-wire ³⁹ (L1, L2, L3, G) Dual mains: 3-wire ³⁹ (L1, L2, L3, G)
	Input voltage range (V)	331-437	340-460	353-477	374-506	408-552
	Frequency (Hz)	40-70				
	Nominal input current (A)	632	599	577	544	497
	Minimum short circuit rating	Dependent on upstream protection. See section for Recommended upstream protection for IEC for details.				–
	Maximum short circuit rating (three cycles)	65 kA l _{cw} 25 kA l _{cw} with maintenance bypass cabinet (GVLBCA200K500H) 45 kA l _{cw} with bottom entry cabinet (GVBECC) 65 kA l _{cw} with bottom entry cabinet (GVBECC and GVLOPT012 installed) 65 kA l _{cc} with backfeed breaker kit (GVLOPT004) installed in the UPS ⁴⁰				–
	Maximum input current (A)	740	731	704	664	607
	Input current limitation (A)	740	740	732	683	626
	Total harmonic distortion (THDI)	<3% at 100% load				
	Input power factor	>0.99 at load >25%, 0.95 at >15% load				
	Protection	Built-in backfeed protection and fuses				
	Ramp-in	Adaptive 1-300 seconds				

39. WYE source – solid grounded and high resistance grounded sources are supported. Corner (line) grounding is not permitted.

40. Refer to the physical short circuit rating label on the UPS for the exact short circuit rating options of the specific UPS.

	Voltage (V)	380	400	415	440	480
Bypass	Connections	4-wire (L1, L2, L3, N, PE) or 3-wire (L1, L2, L3, PE)				4-wire (L1, L2, L3, N, G) or 3-wire (L1, L2, L3, G)
	Bypass voltage range (V)	342-418	360-440	374-457	396-484	432-528
	Frequency (Hz)	50 or 60				
	Frequency range (Hz)	Programmable: ± 1 , ± 3 , ± 10 . Default is ± 3 .				
	Nominal bypass current (A)	624	593	572	539	494
	Minimum short circuit rating	Dependent on upstream protection. See section for Recommended upstream protection for IEC for details.				–
	Maximum short circuit rating (three cycles)	65 kA Icw 25 kA Icw with maintenance bypass cabinet (GVLMBCA200K500H) 45 kA Icw with bottom entry cabinet (GVBEC) 65 kA Icw with bottom entry cabinet (GVBEC and GVLOPT012 installed) 65 kA Icc with backfeed breaker kit (GVLOPT004) installed in the UPS ⁴¹				65 kAIC 65 kAIC with maintenance bypass cabinet (GVLMBCA200K500-G) 45 kAIC Icw with bottom entry cabinet (GVBEC) 65 kAIC Icw with bottom entry cabinet (GVBEC and GVLOPT012 installed) 65 kAIC with backfeed breaker kit (GVLOPT003) installed in the UPS ⁴¹
	I ² t thyristor value (A ² s)	3.1 MA ² s				
	Bypass backfeed protection options	1: Upstream installation of breaker with shunt trip connected to the UPS, OR 2: Installation with maintenance bypass cabinet (GVLMBCA200K500H / GVLMBCA200K500G), OR 3: Installation of backfeed breaker kit (GVLOPT004 / GVLOPT003) in the UPS.				

41. Refer to the physical short circuit rating label on the UPS for the exact short circuit rating options of the specific UPS.

	Voltage (V)	380	400	415	440	480
Output	Connections ⁴²	4-wire (L1, L2, L3, N, PE) or 3-wire (L1, L2, L3, PE)				4-wire (L1, L2, L3, N, G) or 3-wire (L1, L2, L3, G, GEC ⁴³)
	Output voltage regulation	Symmetrical load ± 1% Asymmetrical load ± 3%				
	Overload capacity	Normal operation: 150% for 1 minute, 125% for 10 minutes, (110% continuous ⁴⁴) Battery operation: 125% for 1 minute Bypass operation: 110% continuous, 1600% for 100 milliseconds				Normal operation: 150% for 1 minute, 125% for 10 minutes, (110% continuous ⁴⁴) Battery operation: 125% for 1 minute Bypass operation: 125% continuous, 1600% for 100 milliseconds
	Dynamic load response	± 5% after 2 ms, ± 1% after 50 ms				
	Output power factor	1				
	Nominal output current (A)	608	577	556	525	481
	Minimum short circuit rating ⁴⁵	Dependent on upstream protection. See section for Recommended upstream protection for IEC for details.				–
	Maximum short circuit rating ⁴⁶	65 kA l _{cw} 25 kA l _{cw} with maintenance bypass cabinet GVLMBCA200K500H 45 kA l _{cw} with bottom entry cabinet (GVBECC) 65 kA l _{cw} with bottom entry cabinet (GVBECC and GVLOPT012 installed) 65 kA l _{cc} with backfeed breaker kit GVLOPT004 installed in the UPS ⁴⁷				–
	Inverter output short circuit capabilities	Varies with time. See graph and table values in Inverter Short Circuit Capabilities (Bypass not Available), page 15.				
	Output frequency (Hz)	50/60 (synchronized to bypass), 50/60 Hz ±0.1% (free-running)				
	Synchronized slew rate (Hz/sec)	Programmable: 0.25, 0.5, 1, 2, 4, 6				
	Total harmonic distortion (THDU)	<1% for linear load, <5% for non-linear load				
	Output performance classification (according to IEC/ EN62040-3)	VFI-SS-11				
	Load crest factor	3				
	Load power factor	0.5 leading to 0.5 lagging without derating				

42. The number of output connections must match the number of input connections in a single mains system or the number of bypass connections in a dual mains system.

43. Per NEC 250.30.

44. 110% continuous overload in normal operation at nominal mains voltage and at maximum 40 °C (104 °F) ambient temperature. Contact Schneider Electric to enable this function.

45. Minimum short circuit rating for output takes backfeeding energy through the bypass of parallel UPSs into consideration.

46. Maximum short circuit rating for output takes backfeeding energy through the bypass of parallel UPSs into consideration.

47. Refer to the physical short circuit rating label on the UPS for the exact short circuit rating options of the specific UPS.

	Voltage (V)	380	400	415	440	480
Battery	Charging power in % of output power	0-40% load: 80% 100% load: 15%	0-40% load: 80% 100% load: 20%			
	Maximum charging power (kW)	0-40% load: 320 100% load: 60	0-40% load: 320 100% load: 80			
	Nominal battery voltage (VDC)	480 for 40 blocks 576 for 48 blocks				
	Nominal float voltage (VDC)	545 for 40 blocks 654 for 48 blocks				
	Maximum boost voltage (VDC)	571 for 40 blocks 685 for 48 blocks				
	Temperature compensation (per cell)	-3.3mV/°C for T ≥ 25 °C, 0mV/°C for T < 25 °C				
	End of discharge voltage (full load) (VDC)	384				
	End of discharge voltage (no load) (VDC)	420				
	Battery current at full load and nominal battery voltage (A)	868				
	Battery current at full load and minimum battery voltage (A)	1085				
	Ripple current	< 5% C20 (5 minute runtime)				
	Battery test	Manual/automatic (selectable)				
	Maximum short circuit rating	30 kA				

NOTE: Battery specifications are based on VRLA batteries.

Specifications for 450 kW UPS

	Voltage (V)	380	400	415	440	480
Input	Connections	Single mains: 4-wire (L1, L2, L3, N, PE) or 3-wire (L1, L2, L3, PE) Dual mains: 3-wire (L1, L2, L3, PE)				Single mains: 4-wire ⁴⁸ (L1, L2, L3, N, G) or 3-wire ⁴⁸ (L1, L2, L3, G) Dual mains: 3-wire ⁴⁸ (L1, L2, L3, G)
	Input voltage range (V)	331-437	340-460	353-477	374-506	408-552
	Frequency (Hz)	40-70				
	Nominal input current (A)	711	674	649	612	559
	Minimum short circuit rating	Dependent on upstream protection. See section for Recommended upstream protection for IEC for details.				–
	Maximum short circuit rating (three cycles)	65 kA l _{cw} 25 kA l _{cw} with maintenance bypass cabinet (GVLMBCA200K500H) 45 kA l _{cw} with bottom entry cabinet (GVBECC) 65 kA l _{cw} with bottom entry cabinet (GVBECC and GVLOPT012 installed) 65 kA l _{cc} with backfeed breaker kit (GVLOPT004) installed in the UPS ⁴⁹				–
	Maximum input current (A)	833	822	792	747	682
	Input current limitation (A)	833	833	824	769	705
	Total harmonic distortion (THDI)	<3% at 100% load				
	Input power factor	>0.99 at load >25%, 0.95 at >15% load				
	Protection	Built-in backfeed protection and fuses				
	Ramp-in	Adaptive 1-300 seconds				

48. WYE source – solid grounded and high resistance grounded sources are supported. Corner (line) grounding is not permitted.

49. Refer to the physical short circuit rating label on the UPS for the exact short circuit rating options of the specific UPS.

	Voltage (V)	380	400	415	440	480
Bypass	Connections	4-wire (L1, L2, L3, N, PE) or 3-wire (L1, L2, L3, PE)				4-wire (L1, L2, L3, N, G) or 3-wire (L1, L2, L3, G)
	Bypass voltage range (V)	342-418	360-440	374-457	396-484	432-528
	Frequency (Hz)	50 or 60				
	Frequency range (Hz)	Programmable: ±1, ±3, ±10. Default is ±3.				
	Nominal bypass current (A)	702	667	643	607	556
	Minimum short circuit rating	Dependent on upstream protection. See section for Recommended upstream protection for IEC for details.				–
	Maximum short circuit rating (three cycles)	65 kA l _{cw} 25 kA l _{cw} with maintenance bypass cabinet (GVLMBCA200K500H) 45 kA l _{cw} with bottom entry cabinet (GVBEC) 65 kA l _{cw} with bottom entry cabinet (GVBEC and GVLOPT012 installed) 65 kA l _{cc} with backfeed breaker kit (GVLOPT004) installed in the UPS ⁵⁰				65 kAIC 65 kAIC with maintenance bypass cabinet (GVLMBCA200K500-G) 45 kAIC l _{cw} with bottom entry cabinet (GVBEC) 65 kAIC l _{cw} with bottom entry cabinet (GVBEC and GVLOPT012 installed) 65 kAIC with backfeed breaker kit (GVLOPT003) installed in the UPS ⁵⁰
	I ² t thyristor value (A ² s)	3.1 MA ² s				
	Bypass backfeed protection options	1: Upstream installation of breaker with shunt trip connected to the UPS, OR 2: Installation with maintenance bypass cabinet (GVLMBCA200K500H / GVLMBCA200K500G), OR 3: Installation of backfeed breaker kit (GVLOPT004 / GVLOPT003) in the UPS.				

50. Refer to the physical short circuit rating label on the UPS for the exact short circuit rating options of the specific UPS.

	Voltage (V)	380	400	415	440	480
Output	Connections ⁵¹	4-wire (L1, L2, L3, N, PE) or 3-wire (L1, L2, L3, PE)				4-wire (L1, L2, L3, N, G) or 3-wire (L1, L2, L3, G, GEC ⁵²)
	Output voltage regulation	Symmetrical load $\pm 1\%$ Asymmetrical load $\pm 3\%$				
	Overload capacity	Normal operation: 150% for 1 minute, 125% for 10 minutes, (110% continuous ⁵³) Battery operation: 125% for 1 minute Bypass operation: 110% continuous, 1600% for 100 milliseconds				Normal operation: 150% for 1 minute, 125% for 10 minutes, (110% continuous ⁵³) Battery operation: 125% for 1 minute Bypass operation: 125% continuous, 1600% for 100 milliseconds
	Dynamic load response	$\pm 5\%$ after 2 ms, $\pm 1\%$ after 50 ms				
	Output power factor	1				
	Nominal output current (A)	684	650	626	590	541
	Minimum short circuit rating ⁵⁴	Dependent on upstream protection. See section for Recommended upstream protection for IEC for details.				–
	Maximum short circuit rating ⁵⁵	65 kA l _{cw} 25 kA l _{cw} with maintenance bypass cabinet GVLMBCA200K500H 45 kA l _{cw} with bottom entry cabinet (GVBECC) 65 kA l _{cw} with bottom entry cabinet (GVBECC and GVLOPT012 installed) 65 kA l _{cc} with backfeed breaker kit GVLOPT004 installed in the UPS ⁵⁶				–
	Inverter output short circuit capabilities	Varies with time. See graph and table values in Inverter Short Circuit Capabilities (Bypass not Available), page 15.				
	Output frequency (Hz)	50/60 (synchronized to bypass), 50/60 Hz $\pm 0.1\%$ (free-running)				
	Synchronized slew rate (Hz/sec)	Programmable: 0.25, 0.5, 1, 2, 4, 6				
	Total harmonic distortion (THDU)	<1% for linear load, <5% for non-linear load				
	Output performance classification (according to IEC/ EN62040-3)	VFI-SS-11				
	Load crest factor	3				
	Load power factor	0.5 leading to 0.5 lagging without derating				

51. The number of output connections must match the number of input connections in a single mains system or the number of bypass connections in a dual mains system.

52. Per NEC 250.30.

53. 110% continuous overload in normal operation at nominal mains voltage and at maximum 40 °C (104 °F) ambient temperature. Contact Schneider Electric to enable this function.

54. Minimum short circuit rating for output takes backfeeding energy through the bypass of parallel UPSs into consideration.

55. Maximum short circuit rating for output takes backfeeding energy through the bypass of parallel UPSs into consideration.

56. Refer to the physical short circuit rating label on the UPS for the exact short circuit rating options of the specific UPS.

	Voltage (V)	380	400	415	440	480
Battery	Charging power in % of output power	0-40% load: 80% 100% load: 15%	0-40% load: 80% 100% load: 20%			
	Maximum charging power (kW)	0-40% load: 360 100% load: 67.5	0-40% load: 360 100% load: 90			
	Nominal battery voltage (VDC)	480 for 40 blocks 576 for 48 blocks				
	Nominal float voltage (VDC)	545 for 40 blocks 654 for 48 blocks				
	Maximum boost voltage (VDC)	571 for 40 blocks 685 for 48 blocks				
	Temperature compensation (per cell)	-3.3mV/°C for T ≥ 25 °C, 0mV/°C for T < 25 °C				
	End of discharge voltage (full load) (VDC)	384				
	End of discharge voltage (no load) (VDC)	420				
	Battery current at full load and nominal battery voltage (A)	977				
	Battery current at full load and minimum battery voltage (A)	1221				
	Ripple current	< 5% C20 (5 minute runtime)				
	Battery test	Manual/automatic (selectable)				
	Maximum short circuit rating	30 kA				

NOTE: Battery specifications are based on VRLA batteries.

Specifications for 500 kW UPS

	Voltage (V)	380	400	415	440	480
Input	Connections	Single mains: 4-wire (L1, L2, L3, N, PE) or 3-wire (L1, L2, L3, PE) Dual mains: 3-wire (L1, L2, L3, PE)				Single mains: 4-wire ⁵⁷ (L1, L2, L3, N, G) or 3-wire ⁵⁷ (L1, L2, L3, G) Dual mains: 3-wire ⁵⁷ (L1, L2, L3, G)
	Input voltage range (V)	331-437	340-460	353-477	374-506	408-552
	Frequency (Hz)	40-70				
	Nominal input current (A)	790	749	721	680	621
	Minimum short circuit rating	Dependent on upstream protection. See section for Recommended upstream protection for IEC for details.				–
	Maximum short circuit rating (three cycles)	65 kA l _{cw} 25 kA l _{cw} with maintenance bypass cabinet (GVLBCA200K500H) 45 kA l _{cw} with bottom entry cabinet (GVBECC) 65 kA l _{cw} with bottom entry cabinet (GVBECC and GVLOPT012 installed) 65 kA l _{cc} with backfeed breaker kit (GVLOPT004) installed in the UPS ⁵⁸				–
	Maximum input current (A)	925	914	880	830	758
	Input current limitation (A)	925	925	915	854	783
	Total harmonic distortion (THDI)	<3% at 100% load				
	Input power factor	>0.99 at load >25%, 0.95 at >15% load				
	Protection	Built-in backfeed protection and fuses				
	Ramp-in	Adaptive 1-300 seconds				

57. WYE source – solid grounded and high resistance grounded sources are supported. Corner (line) grounding is not permitted.

58. Refer to the physical short circuit rating label on the UPS for the exact short circuit rating options of the specific UPS.

	Voltage (V)	380	400	415	440	480
Bypass	Connections	4-wire (L1, L2, L3, N, PE) or 3-wire (L1, L2, L3, PE)				4-wire (L1, L2, L3, N, G) or 3-wire (L1, L2, L3, G)
	Bypass voltage range (V)	342-418	360-440	374-457	396-484	432-528
	Frequency (Hz)	50 or 60				
	Frequency range (Hz)	Programmable: ±1, ±3, ±10. Default is ±3.				
	Nominal bypass current (A)	780	741	715	674	618
	Minimum short circuit rating	Dependent on upstream protection. See section for Recommended upstream protection for IEC for details.				–
	Maximum short circuit rating (three cycles)	65 kA l _{cw} 25 kA l _{cw} with maintenance bypass cabinet (GVLMBCA200K500H) 45 kA l _{cw} with bottom entry cabinet (GVBEC) 65 kA l _{cw} with bottom entry cabinet (GVBEC and GVLOPT012 installed) 65 kA l _{cc} with backfeed breaker kit (GVLOPT004) installed in the UPS ⁵⁹				65 kAIC 65 kAIC with maintenance bypass cabinet (GVLMBCA200K500-G) 45 kAIC l _{cw} with bottom entry cabinet (GVBEC) 65 kAIC l _{cw} with bottom entry cabinet (GVBEC and GVLOPT012 installed) 65 kAIC with backfeed breaker kit (GVLOPT003) installed in the UPS ⁵⁹
	I ² t thyristor value (A ² s)	3.1 MA ² s				
	Bypass backfeed protection options	1: Upstream installation of breaker with shunt trip connected to the UPS, OR 2: Installation with maintenance bypass cabinet (GVLMBCA200K500H / GVLMBCA200K500G), OR 3: Installation of backfeed breaker kit (GVLOPT004 / GVLOPT003) in the UPS.				

59. Refer to the physical short circuit rating label on the UPS for the exact short circuit rating options of the specific UPS.

	Voltage (V)	380	400	415	440	480
Output	Connections ⁶⁰	4-wire (L1, L2, L3, N, PE) or 3-wire (L1, L2, L3, PE)				4-wire (L1, L2, L3, N, G) or 3-wire (L1, L2, L3, G, GEC ⁶¹)
	Output voltage regulation	Symmetrical load ± 1% Asymmetrical load ± 3%				
	Overload capacity	Normal operation: 150% for 1 minute, 125% for 10 minutes, (110% continuous ⁶²) Battery operation: 125% for 1 minute Bypass operation: 110% continuous, 1600% for 100 milliseconds				Normal operation: 150% for 1 minute, 125% for 10 minutes, (110% continuous ⁶²) Battery operation: 125% for 1 minute Bypass operation: 125% continuous, 1600% for 100 milliseconds
	Dynamic load response	± 5% after 2 ms, ± 1% after 50 ms				
	Output power factor	1				
	Nominal output current (A)	760	722	696	656	601
	Minimum short circuit rating ⁶³	Dependent on upstream protection. See section for Recommended upstream protection for IEC for details.				–
	Maximum short circuit rating ⁶⁴	65 kA l _{cw} 25 kA l _{cw} with maintenance bypass cabinet GVLMBCA200K500H 45 kA l _{cw} with bottom entry cabinet (GVBECC) 65 kA l _{cw} with bottom entry cabinet (GVBECC and GVLOPT012 installed) 65 kA l _{cc} with backfeed breaker kit GVLOPT004 installed in the UPS ⁶⁵				–
	Inverter output short circuit capabilities	Varies with time. See graph and table values in Inverter Short Circuit Capabilities (Bypass not Available), page 15.				
	Output frequency (Hz)	50/60 (synchronized to bypass), 50/60 Hz ±0.1% (free-running)				
	Synchronized slew rate (Hz/sec)	Programmable: 0.25, 0.5, 1, 2, 4, 6				
	Total harmonic distortion (THDU)	<1% for linear load, <5% for non-linear load				
	Output performance classification (according to IEC/ EN62040-3)	VFI-SS-11				
	Load crest factor	3				
	Load power factor	0.5 leading to 0.5 lagging without derating				

60. The number of output connections must match the number of input connections in a single mains system or the number of bypass connections in a dual mains system.

61. Per NEC 250.30.

62. 110% continuous overload in normal operation at nominal mains voltage and at maximum 40 °C (104 °F) ambient temperature. Contact Schneider Electric to enable this function.

63. Minimum short circuit rating for output takes backfeeding energy through the bypass of parallel UPSs into consideration.

64. Maximum short circuit rating for output takes backfeeding energy through the bypass of parallel UPSs into consideration.

65. Refer to the physical short circuit rating label on the UPS for the exact short circuit rating options of the specific UPS.

	Voltage (V)	380	400	415	440	480
Battery	Charging power in % of output power	0-40% load: 80% 100% load: 15%	0-40% load: 80% 100% load: 20%			
	Maximum charging power (kW)	0-40% load: 400 100% load: 75	0-40% load: 400 100% load: 100			
	Nominal battery voltage (VDC)	480 for 40 blocks 576 for 48 blocks				
	Nominal float voltage (VDC)	545 for 40 blocks 654 for 48 blocks				
	Maximum boost voltage (VDC)	571 for 40 blocks 685 for 48 blocks				
	Temperature compensation (per cell)	-3.3mV/°C for T ≥ 25 °C, 0mV/°C for T < 25 °C				
	End of discharge voltage (full load) (VDC)	384				
	End of discharge voltage (no load) (VDC)	420				
	Battery current at full load and nominal battery voltage (A)	1085				
	Battery current at full load and minimum battery voltage (A)	1356				
	Ripple current	< 5% C20 (5 minute runtime)				
	Battery test	Manual/automatic (selectable)				
	Maximum short circuit rating	30 kA				

NOTE: Battery specifications are based on VRLA batteries.

Upstream and Downstream Protection for UL

Preconditions for Live Swap of Power Modules

Live Swap of power modules is only allowed under the following preconditions for the UPS installation; Follow either scenario 1 or scenario 2:

Preconditions for UPS installation — scenario 1 with instantaneous override values and trip times set according to the tables below in Recommended Upstream Protection for UL, page 56	Preconditions for UPS installation — scenario 2 with alternative breaker configurations supported with GVLOPT011 and breaker with ERMS mode ⁶⁶
Circuit breakers must have instantaneous trip time of maximum 50 ms.	Circuit breakers must be installed for input (unit input breaker UIB) and bypass (static switch input breaker SSIB).
Circuit breakers must have instantaneous override values set according to the table below.	Circuit breakers (UIB, SSIB) must be equipped with NEC 240.87, NFPA70E, IEEE1584, or EN51110-1 compliant ERMS mode.
Circuit breakers must be installed for input (unit input breaker UIB) and bypass (static switch input breaker SSIB).	For parallel systems with three or more UPSs: Circuit breakers must be installed for the output (unit output breaker UOB) of each UPS. The unit output breaker (UOB) is sized as the static switch input breaker (SSIB).
For parallel system with three or more UPSs: Circuit breakers must be installed for the output (unit output breaker UOB) of each UPS. The unit output breaker (UOB) is sized as the static switch input breaker (SSIB).	Circuit breaker (UOB) must be equipped with NEC 240.87, NFPA70E, IEEE1584, or EN51110-1 compliant ERMS mode.
Live Swap is not supported for >65kA _{bf} installations where current limiting disconnect devices are used to protect the UPS.	GVLOPT011 (Galaxy VL door switch kit) must be installed in the UPS and connected so ERMS mode is set to ON on UIB and SSIB and UOB when the front door of the UPS is opened.
	In ERMS mode, the instantaneous trip current shall be set to 5000 A or less. All time-delay settings shall be set to zero.

Schneider Electric reserves the right to remove the Live Swap label from the product front if the preconditions for scenario 1 or scenario 2 are not met.

⚡⚠ DANGER

HAZARD OF ELECTRIC SHOCK, EXPLOSION, OR ARC FLASH

Only perform Live Swap of the power modules in UPS installations that follow the preconditions for scenario 1 or scenario 2.

Failure to follow these instructions will result in death or serious injury.

Recommended Upstream Protection for UL

The bypass/output breakers are sized based on the nominal current +10%. This is to accommodate either low grid voltage or deviation in cable length between parallel UPSs. The battery breakers are sized based on the end-of-discharge voltage which has been defined as 380 VDC.

NOTE: Overcurrent protection is to be provided by others and marked with its function.

66. Energy Reduction Maintenance Settings (ERMS)

UPS rating	200 kW		250 kW	
	Input	Bypass	Input	Bypass
Breaker type	LJF36400CU31X	LJF36400CU31X	LJF36400CU31X	LJF36400CU31X
Ir	320	280	400	360
tr	≥4	≥4	≥4	≥4
li (x In)	≤12	≤12	≤12	≤12

UPS rating	300 kW		350 kW		400 kW	
	Input	Bypass	Input	Bypass	Input	Bypass
Breaker type	PJF36060CU31-A	PJF36060CU31A	PJF36060CU31A	PJF36060CU31A	PJF36080CU31A	PJF36060CU31A
Ir	480	420	540	480	640	540
tr	≥4	≥4	≥4	≥4	≥4	≥4
li (x In)	≤12	≤12	≤10	≤12	≤10	≤12

UPS rating	450 kW		500 kW	
	Input	Bypass	Input	Bypass
Breaker type	PJF36080CU31A	PJF36080CU31A	PJF36080CU31A	PJF36080CU31A
Ir	720	640	800	720
tr	≥4	≥4	≥4	≥4
li (x In)	≤8	≤10	≤8	≤10

Recommended Cable Sizes for UL

⚡⚠ DANGER

HAZARD OF ELECTRIC SHOCK, EXPLOSION, OR ARC FLASH

- All wiring must comply with all applicable national and/or electrical codes.
- The maximum allowable cable size is 600 kcmil for input/bypass/output/neutral/ground cables.
- The maximum allowable cable size is 500 kcmil for DC cables.
- Shrink sleeve must be fitted over cable lug crimped zone and must overlap with the cable insulation on all power cables.

Failure to follow these instructions will result in death or serious injury.

The maximum number of cable connections per busbar:

- 4 on input/output/bypass busbars
- 4 x 600 kcmil on input/output/bypass busbars
- 5 x 500 kcmil or 8 x 300 kcmil on DC+/DC- busbars
- 8 on N busbar
- 16 on ground busbar

NOTE: Overcurrent protection is to be provided by others.

Cable sizes in this manual are based on Table 310.15 (B)(16) of the National Electrical Code (NEC) with the following assertions⁶⁷:

- 90 °C (194 °F) conductors (75 °C (167 °F) termination)
- An ambient temperature of 30 °C (86 °F)
- Use of copper or aluminum conductors

If the ambient temperature is greater than 30 °C (86 °F), larger conductors are to be selected in accordance with the correction factors of the NEC.

Equipment grounding conductors (EGC) are sized in accordance with the minimum requirements in NEC Article 250.122 and Table 250.122.

NOTE: 100% rated circuit breakers for UIB, UOB, MBB, SSIB. 100% rated breakers for battery breakers.

The bypass/output cables are sized based on the nominal current +10%. This is to accommodate either low grid voltage or deviation in length between parallel UPSs. The battery cables are sized based on end-of-discharge voltage which has been defined as 380 VDC.

Copper

UPS rating	200 kW	250 kW	300 kW	350 kW	400 kW	450 kW	500 kW
Voltage (V)	480	480	480	480	480	480	480
Input phases (AWG/kcmil)	1 x 350	1 x 500	2 x 4/0	2 x 300	2 x 350	2 x 400	2 x 500
Input EGC (AWG/kcmil)	1 x 3	1 x 3	2 x 2	2 x 1	2 x 1/0	2 x 1/0	2 x 1/0
Bypass/output phases (AWG/kcmil)	1 x 300	1 x 400	1 x 600	2 x 250	2 x 300	2 x 350	2 x 400
Bypass EGC/output EGC (AWG/kcmil)	1 x 4	1 x 3	1 x 2	2 x 2	2 x 1	2 x 1/0	2 x 1/0
DC+/DC- (AWG/kcmil)	2 x 300	2 x 400	3 x 350	3 x 400	4 x 350	4 x 400	4 x 500

67. Using non-recommended cable sizes will affect the eConversion limits for parallel UPS systems. Be sure to check the Standard eConversion Limits Based on Non-recommended Cable Sizes, page 61 table in this installation scenario.

Copper (Continued)

UPS rating	200 kW	250 kW	300 kW	350 kW	400 kW	450 kW	500 kW
Voltage (V)	480	480	480	480	480	480	480
DC EGC (AWG/kcmil)	2 x 1	2 x 1/0	3 x 2/0	3 x 2/0	4 x 3/0	4 x 4/0	4 x 4/0
Inverter midpoint cable for 3-wire parallel (AWG/kcmil)	1 x 350	1 x 500	2 x 4/0	2 x 300	2 x 350	2 x 400	2 x 500

Aluminum

UPS rating	200 kW	250 kW	300 kW	350 kW	400 kW	450 kW	500 kW
Voltage (V)	480	480	480	480	480	480	480
Input phases (AWG/kcmil)	1 x 500	2 x 250	2 x 300	2 x 400	2 x 500	(3 x 300) ⁶⁸	(3 x 400) ⁶⁸
Input EGC (AWG/kcmil)	1 x 1	2 x 1	2 x 1/0	2 x 2/0	2 x 3/0	3 x 3/0	3 x 3/0
Bypass/output phases (AWG/kcmil)	1 x 400	1 x 600	2 x 250	2 x 350	2 x 400	2 x 500	2 x 600
Bypass EGC/output EGC (AWG/kcmil)	1 x 2	1 x 1	2 x 1/0	2 x 1/0	2 x 2/0	2 x 3/0	2 x 3/0
DC+/DC- (AWG/kcmil)	2 x 500	3 x 300	3 x 500	4 x 350	4 x 500	5 x 400	5 x 500
DC EGC (AWG/kcmil)	1 x 2/0	3 x 3/0	3 x 4/0	4 x 4/0	4 x 250	5 x 350	5 x 350
Inverter midpoint cable for 3-wire parallel (AWG/kcmil)	1 x 500	2 x 250	2 x 300	2 x 400	2 x 500	3 x 300	3 x 400

Guidance for Organizing Input, Bypass, And Output Cables

The input, bypass, and output cables must be grouped in circuits. On raceways, use one of the two shown cable formations.

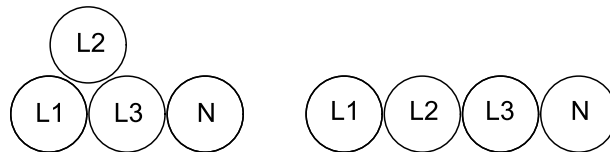

Load Sharing in Bypass Operation in a Parallel System

The impedance of the bypass paths need to be controlled in a parallel UPS system. When operating in bypass mode, the parallel load sharing is determined by the total impedance of the bypass path comprising cables, switchgear, static bypass switch, and cable formation.

68. For parallel UPS systems, the Standard eConversion Limits Based on Non-recommended Cable Sizes, page 61 table shall be used.

Parallel System – Dual Mains

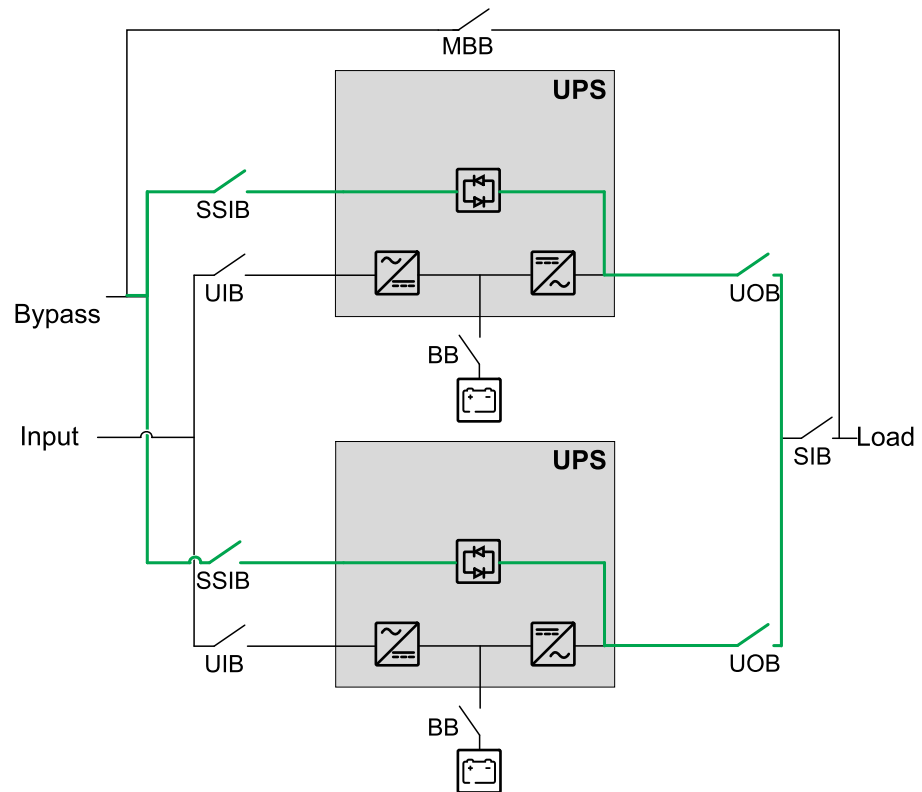

NOTICE

RISK OF EQUIPMENT DAMAGE

To ensure correct load sharing in bypass operation in a parallel system, the following recommendations apply:

- The bypass cables must be the same length for all UPSs.
- The output cables must be the same length for all UPSs.
- The input cables must be the same length for all UPSs in a single mains system.
- Cable formation recommendations must be followed.
- The reactance of busbar layout in the bypass/input and output switchgear must be the same for all UPSs.

If the above recommendations are not followed the result can be uneven load sharing in bypass and overload of individual UPSs.

Failure to follow these instructions can result in equipment damage.

eConversion Limits for Parallel UPS Systems

eConversion requires a minimum load percentage on the UPS for parallel UPS systems. The minimum required load percentages depend on the power cable sizes.

NOTE: For installations using the recommended cable sizes, refer to the Standard eConversion Limits Based on Recommended Cable Sizes, page 61 table for the minimum load percentages.

Standard eConversion Limits Based on Recommended Cable Sizes

UPS rating	Minimum load %
200 kW	34%
250 kW	27%
300 kW	23%
350 kW	19%
400 kW	17%
450 kW	15%
500 kW	14%

The other prerequisites to use this table include:

- The values are calculated based on the use of recommended cable sizes.
- Installations with maximum two cables on each phase are supported.
- The bypass and output cables must have equal length for all UPSs.

NOTE: For certain installations such as installations with 80% breakers or where other installation methods have been applied to comply with the IEC standard, it is possible that non-recommended cable sizes will be used. For installations using non-recommended cable sizes, refer to the Standard eConversion Limits Based on Non-recommended Cable Sizes, page 61 table for the voltage ratings percentages.

Standard eConversion Limits Based on Non-recommended Cable Sizes

UPS rating	Minimum load %
200 kW	50%
250 kW	40%
300 kW	34%
350 kW	29%
400 kW	25%
450 kW	22%
500 kW	20%

The other prerequisites to use this table include:

- The values are calculated based on the scenario of using non-recommended cable sizes.
- Installations with three or four cables on each phase are supported.
- The bypass and output cables must have equal length for all UPSs.

Recommended Bolt and Lug Sizes for UL

NOTICE

RISK OF EQUIPMENT DAMAGE

Use only UL approved compression cable lugs.

Failure to follow these instructions can result in equipment damage.

Copper

Cable size	Bolt size	Cable lug type (one hole)	Cable lug type (two hole NEMA)	Crimping tool	Die
1/0 AWG	M10x35mm	LCB1/0-12-X	LCC1/0-12-X	CT-930	CD-920-1/0 Pink P42
2/0 AWG	M10x35mm	LCB2/0-12-X	LCC2/0-12-X	CT-930	CD-920-2/0 Black P45
3/0 AWG	M10x35mm	LCB3/0-12-X	LCC3/0-12-X	CT-930	CD-920-3/0 Orange P50
4/0 AWG	M10x35mm	LCB4/0-12-X	LCC4/0-12-X	CT-930	CD-920-4/0 Purple P54
250 kcmil	M10x35mm	LCB250-12-X	LCC250-12-X	CT-930	CD-920-250 Yellow P62
300 kcmil	M10x35mm	LCB300-12-X	LCC300-12-X	CT-930	CD-920-300 Red P66
350 kcmil	M10x35mm	LCB350-12-X	LCC350-12-X	CT-930	CD-920-350 Red P71
400 kcmil	M10x35mm	LCB400-12-X	LCC400-12-6	CT-930	CD-920-400 Blue P76
450 kcmil	M10x35mm	—	LCC450-12-6	CT-930	—
500 kcmil	M10x35mm	LCB500-12-X	LCC500-12-6	CT-930	CD-920-500 Blue P87

Aluminum

Cable size	Bolt size	Cable lug type (one hole)	Cable lug type (two hole NEMA)	Crimping tool	Die
1/0 AWG	M10x35mm	LAA1/0-12-5	LAB1/0-12-X	CT-930	CD-920-1/0 Pink P42
2/0 AWG	M10x35mm	LAA2/0-12-5	LAB2/0-12-5	CT-930	CD-920-2/0 Black P45
3/0 AWG	M10x35mm	LAA3/0-12-5	LAB3/0-12-5	CT-930	CD-920-3/0 Orange P50
4/0 AWG	M10x35mm	LAA4/0-12-5	LAB4/0-12-5R	CT-930	CD-920-4/0 Purple P54
250 kcmil	M10x35mm	LAA250-12-5	LAB250-12-5	CT-930	CD-920-250 Yellow P62
300 kcmil	M10x35mm	LAA300-12-2	LAB300-12-2	CT-930	CD-920-300 Red P66
350 kcmil	M10x35mm	LAA350-12-2	LAB350-12-2R	CT-930	CD-920-350 Red P71
400 kcmil	M10x35mm	—	LAB400-12-2	CT-930	CD-920-400 Blue P76
500 kcmil	M10x35mm	LAA500-12-2	LAB500-12-2R	CT-930	CD-920-500 Blue P87

Torque Specifications

Bolt size	Torque
M6	5 Nm (3.69 lb-ft / 44.3 lb-in)
M8	17.5 Nm (12.91 lb-ft / 154.9 lb-in)
M10	30 Nm (22 lb-ft / 194.7 lb-in)
M12	50 Nm (36.87 lb-ft / 442.5 lb-in)

Physical

UPS Shipping Weights and Dimensions

Commercial reference	Weight kg (lbs)	Height mm (in)	Width mm (in)	Depth mm (in)	Number of preinstalled power modules in the UPS	Number of power modules shipped separately ⁶⁹	Number of extra power modules that can be ordered ⁷⁰
GVL200K500DS	620 (1367)	2145 (84.4)	950 (37.4)	1100 (43.3)	4	0	6
GVL300K500DS	620 (1367)	2145 (84.4)	950 (37.4)	1100 (43.3)	4	2	4
GVL400K500DS	620 (1367)	2145 (84.4)	950 (37.4)	1100 (43.3)	4	4	2
GVL500KDS	620 (1367)	2145 (84.4)	950 (37.4)	1100 (43.3)	4	6	0

Power Module Shipping Weights and Dimensions

Commercial reference	Weight kg (lbs)	Height mm (in)	Width mm (in)	Depth mm (in)
GVPM50KD	62 (137)	330 (13)	580 (22.8)	780 (30.7)

UPS Weights and Dimensions

UPS rating	Weight kg (lbs)	Height mm (in)	Width mm (in)	Depth mm (in)
200 kW	550 (1212)	1970 (78)	850 (33)	925 (36)
250 kW	588 (1296)	1970 (78)	850 (33)	925 (36)
300 kW	626 (1380)	1970 (78)	850 (33)	925 (36)
350 kW	664 (1463)	1970 (78)	850 (33)	925 (36)
400 kW	702 (1547)	1970 (78)	850 (33)	925 (36)
450 kW	740 (1631)	1970 (78)	850 (33)	925 (36)
500 kW	778 (1715)	1970 (78)	850 (33)	925 (36)

69. See Power Module Shipping Weights and Dimensions, page 64 for shipping weight and dimensions for the separately shipped power module.

70. See Power Module Shipping Weights and Dimensions, page 64 for shipping weight and dimensions for the extra power modules which are shipped separately.

Clearance

NOTE: Clearance dimensions are published for airflow and service access only. Consult with the local safety codes and standards for additional requirements in your local area.

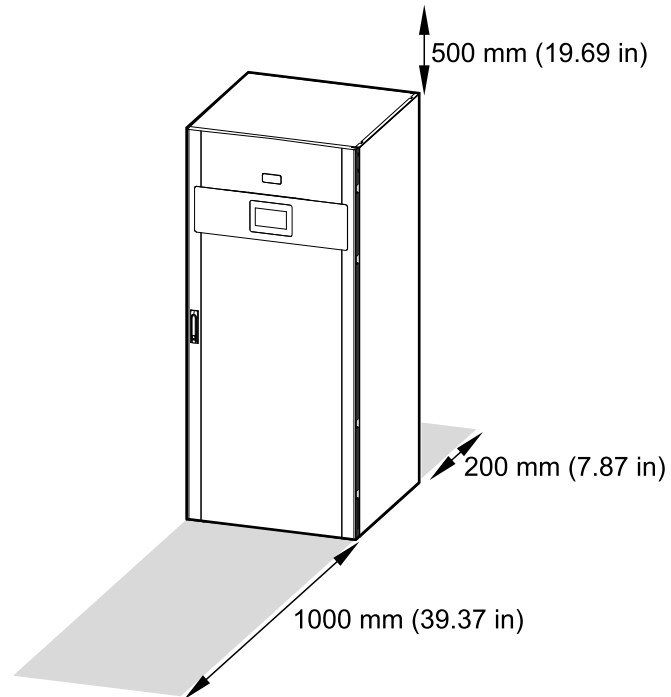

Environment

	Operating	Storage
Temperature	0 °C to 40 °C (32 °F to 104 °F) without load derating. 40 °C to 50 °C (104 °F to 122 °F) when derated to 70% power.	-25 °C to 55 °C (-13 °F to 131 °F) for systems without batteries.
Relative humidity	5-95% non-condensing	10-80% non-condensing
Elevation	Designed for operation in 0-3000 m (0-10000 feet) elevation. Derating required from 1000-3000 m (3300-10000 feet) with forced air cooling: Up to 1000 m (3300 feet): 1.000 Up to 1500 m (5000 feet): 1.000 conditioned by 2 x 300 mm ² input cables at 500 kW Up to 1500 m (5000 feet) : 0.975 Up to 2000 m (6600 feet): 1.000 conditioned by 2 x 300 mm ² input cables at 500 kW Up to 2000 m (6600 feet): 0.950 Up to 2500 m (8300 feet): 0.975 conditioned by 2 x 300 mm ² input cables at 500 kW Up to 2500 m (8300 feet): 0.925 Up to 3000 m (10000 feet): 0.950 conditioned by 2 x 300 mm ² input cables at 500 kW Up to 3000 m (10000 feet): 0.900 Derating required from 1000-3000 m (3300-10000 feet) with convection cooling: Up to 1000 m (3300 feet): 1.000 Up to 1500 m (5000 feet) : 0.985 Up to 2000 m (6600 feet): 0.970 Up to 2500 m (8300 feet): 0.955 Up to 3000 m (10000 feet): 0.940	
Audible noise one meter (three feet) from unit	62 dB at 70% load 68 dB at 100% load for 480 V systems	
Protection class	IP20	
Color	RAL 9003, gloss level 85%	

Heat Dissipation for 480 V in BTU/hr

200 kW	Normal operation	ECO mode	eConversion	Battery operation
Voltage (V)	480			
25% load	6555	1897	3304	8039
50% load	9829	2405	3795	13109
75% load	14202	3089	4127	18563
100% load	19658	3429	4810	25484

250 kW	Normal operation	ECO mode	eConversion	Battery operation
Voltage (V)	480			
25% load	7964	2154	4130	9582
50% load	12286	3007	4744	15927
75% load	17753	3862	5159	23203
100% load	24572	4286	6013	31855

300 kW	Normal operation	ECO mode	eConversion	Battery operation
Voltage (V)	480			
25% load	9556	2585	4956	11219
50% load	14743	3608	5692	19113
75% load	21303	4634	6191	27844
100% load	29486	5144	7216	38226

350 kW	Normal operation	ECO mode	eConversion	Battery operation
Voltage (V)	480			
25% load	11149	2711	5472	12764
50% load	17833	3604	6641	21656
75% load	24854	4501	7223	32485
100% load	34401	6001	8418	44597

400 kW	Normal operation	ECO mode	eConversion	Battery operation
Voltage (V)	480			
25% load	12742	3099	6254	14587
50% load	20381	4119	7590	24750
75% load	28404	5144	8255	37125
100% load	39315	6858	9621	50968

450 kW	Normal operation	ECO mode	eConversion	Battery operation
Voltage (V)	480			
25% load	14335	3486	7036	15994
50% load	22928	4634	7755	27844
75% load	33172	6951	9287	41766
100% load	45856	7716	10824	57339

500 kW	Normal operation	ECO mode	eConversion	Battery operation
Voltage (V)	480			
25% load	15927	3873	7818	17771
50% load	25476	5149	8616	30938
75% load	36858	7723	10319	46407
100% load	50952	8573	12026	63710

Heat Dissipation for Transformer Cabinets in BTU/hr

Commercial reference	GVIT300	GVIT500	GVOT300	GVOT500
100% load	5466	7165	5123	7862

Airflow Values

Indicative Airflow Values in m³/Hour Based on a 30 °C (86 °F) Environment

UPS rating	200 kW	250 kW	300 kW	350 kW	400 kW	450 kW	500 kW
50% load	1617	1920	2223	2526	2829	3132	3435
75% load	2102	2526	2950	3375	3799	4223	4749
90% load	2344	2829	3314	3799	4365	4911	5436
100% load	2405	2905	3405	3905	4547	5087	5709

Indicative Airflow Values in m³/Hour Based on a 40 °C (104 °F) Environment

UPS rating	200 kW	250 kW	300 kW	350 kW	400 kW	450 kW	500 kW
50% load	1920	2299	2678	3056	3435	3814	4193
75% load	2284	2753	3223	3693	4163	4774	5284
90% load	2465	2981	3496	4112	4668	5224	5860
100% load	2647	3208	3769	4471	5072	5754	6416

Drawings

NOTE: A comprehensive set of drawings is available on www.se.com.

NOTE: These drawings are for reference ONLY – subject to change without notice.

Galaxy VL 200-500 kW 480 V UPS

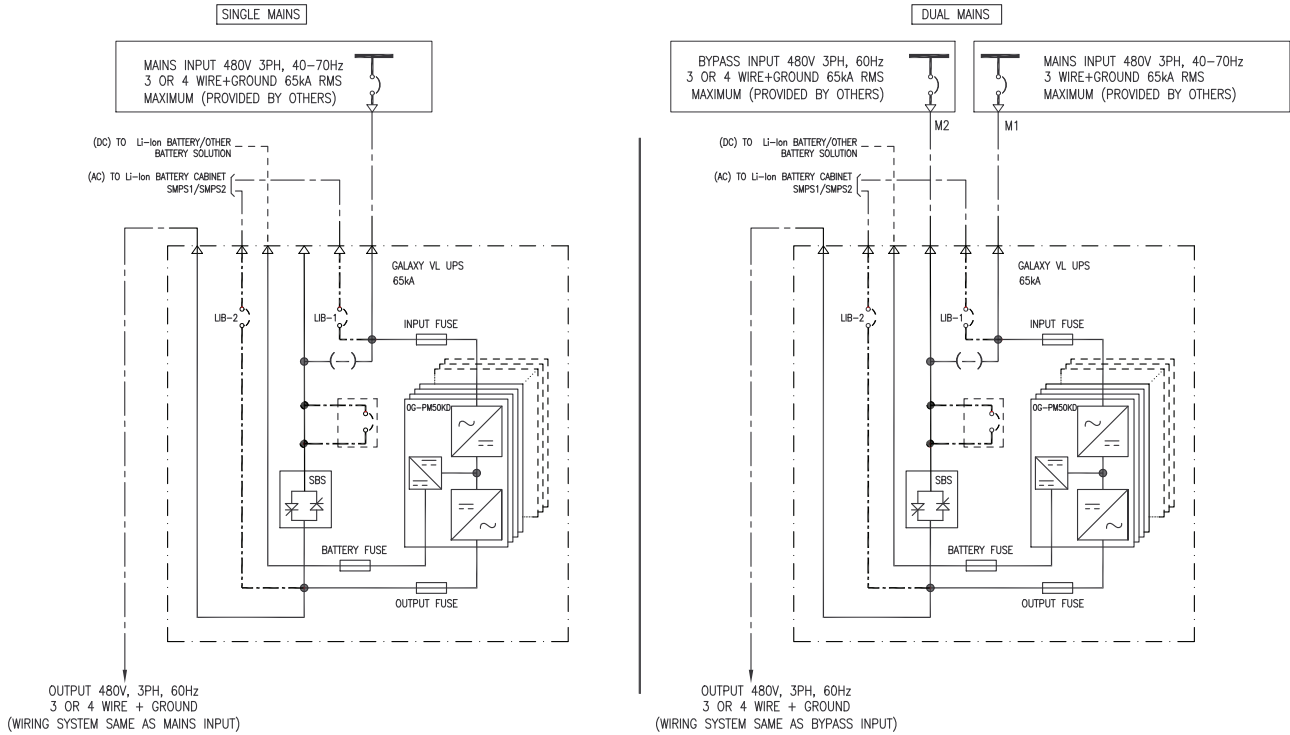

Options

Configuration Options

- Compact design, high density technology, and modular architecture
- Single or dual mains
- Up to 6+0 UPSs in parallel for capacity
- Up to 5+1 UPSs in parallel for redundancy
- Default top cable entry
- ECO mode
- eConversion mode
- EcoStruxure IT compatible
- Generator compatible
- Touchscreen LCD
- Replacement of power module in any operation mode (Live Swap)⁷¹
- Simplified common battery (VRLA/Lithium-ion) supported

71. In all systems that live up to the prerequisites for Live Swap.

Hardware Options

NOTE: All hardware options listed here may not be available in all regions.

Power Module

- Power module 50 kW (GVPM50KD)

Lithium-ion Battery Cabinet

Battery cabinet including Lithium-ion batteries and battery breaker.

- Galaxy Lithium-ion battery cabinet with 16 battery modules (LIBSESMG16UL)
- Galaxy Lithium-ion battery cabinet with 17 battery modules (LIBSESMG17UL)

Maintenance Bypass Cabinet

Maintenance bypass cabinet for complete isolation of the UPS during service operations. Only for single UPS.

- 200-500 kW maintenance bypass cabinet with backfeed (GVLBCA200K500G)

Input and Output Transformer Cabinet

Input and output transformer cabinet for 600 V. The solution consists of one input transformer cabinet, one output transformer cabinet, and the UPS for a single mains system. The solution consists of two input transformer cabinets, one output transformer cabinet, and the UPS for a dual mains system. Each input transformer cabinet requires installation of a surge protection device which is included in the order, but shipped separately, for installation on site.

- Galaxy V series input transformer cabinet 300 kW, 600 V In, 480 V Out (GVIT300)
- Galaxy V series output transformer cabinet 300 kW, 480 V In, 600 V Out (GVOT300)
- Galaxy V series input transformer cabinet 500 kW, 600 V In, 480 V Out (GVIT500)
- Galaxy V series output transformer cabinet 500 kW, 480 V In, 600 V Out (GVOT500)

Bottom Entry Cabinet

Bottom entry cabinet for cable entry through the bottom of the system.

- Bottom entry cabinet (GVBEC)

Optional Installation Kits

- Seismic kit for UPS, maintenance bypass cabinet, and bottom entry cabinet (GVLOPT002)
- Backfeed kit for UPS (GVLOPT003)

- Parallel kit for UPS (GVLOPT006)
- SKRU kit (GVSOPT004)
- Door switch option kit (GVLOPT011)
- Bottom entry cabinet 65 kAIC kit for Galaxy VL (GVLOPT012)

Optional Network Management Card

- Network Management Card LCES2 with Modbus, Ethernet and AUX sensors (AP9644)

Air Filter

- Performance air filter kit for UPS (GVLOPT001)

Temperature Sensors

- Temperature sensor for network management card (AP9335T)
- Temperature/humidity sensor for network management card (AP9335TH)

Weights and Dimensions for Options

NOTE: Not all options listed here are available for all UPS models. Refer to the hardware options list for the relevant UPS model.

Maintenance Bypass Cabinet Shipping Weights and Dimensions

Commercial reference	Weight kg (lbs)	Height mm (in)	Width mm (in)	Depth mm (in)
GVLMBCA200K500G	209 (461)	2134 (84)	635 (25)	990 (38.97)

Maintenance Bypass Cabinet Weights and Dimensions

Commercial reference	Weight kg (lbs)	Height mm (in)	Width mm (in)	Depth mm (in)
GVLMBCA200K500G	158 (348)	1970 (77.55)	500 (19.68)	847 (33.34)

Input and Output Transformer Cabinet Shipping Weights and Dimensions

Commercial reference	Weight kg (lbs)	Height mm (in)	Width mm (in)	Depth mm (in)
GVIT300 ⁷²	698 (1539)	2138 (84.2)	935 (36.8)	990 (39)
GVIT500 ⁷²	853 (1881)	2138 (84.2)	935 (36.8)	990 (39)
GVOT300	659 (1453)	2138 (84.2)	935 (36.8)	990 (39)
GVOT500	827 (1823)	2138 (84.2)	935 (36.8)	990 (39)

Surge Protection Device Shipping Weights and Dimensions

Commercial reference	Weight kg (lbs)	Height mm (in)	Width mm (in)	Depth mm (in)
SSP08EMA12	9 (20)	28.2 (11.1)	25.4 (10)	13.5 (5)

Input and Output Transformer Cabinet Weights and Dimensions

Commercial reference	Weight kg (lbs)	Height mm (in)	Width mm (in)	Depth mm (in)
GVIT300 with surge protection device SSP08EMA12 (GVSOPTSPD) installed	640 (1411)	1970 (77.55)	800 (31.49)	847 (33.34)
GVIT500 with surge protection device	795 (1753)	1970 (77.55)	800 (31.49)	847 (33.34)

72. A surge protection device (SSP08EMA12) is shipped separately and must be installed in the input transformer cabinet. See Surge Protection Device Shipping Weights and Dimensions, page 73.

Commercial reference	Weight kg (lbs)	Height mm (in)	Width mm (in)	Depth mm (in)
SSP08EMA12 (GVSOPTSPD) installed				
GVOT300	602 (1327)	1970 (77.55)	800 (31.49)	847 (33.34)
GVOT500	767 (1691)	1970 (77.55)	800 (31.49)	847 (33.34)

Bottom Entry Cabinet Shipping Weight and Dimensions

Commercial reference	Weight kg (lbs)	Height mm (in)	Width mm (in)	Depth mm (in)
GVBEC	96 (212)	2134 (84.01)	535 (21.06)	990 (38.97)

Bottom Entry Cabinet Weight and Dimensions

Commercial reference	Weight kg (lbs)	Height mm (in)	Width mm (in)	Depth mm (in)
GVBEC	85 (188)	1970 (77.55)	400 (15.74)	850 (33.46)

Limited Factory Warranty

One-Year Factory Warranty

The limited warranty provided by Schneider Electric in this Statement of Limited Factory Warranty applies only to products you purchase for your commercial or industrial use in the ordinary course of your business.

Terms of Warranty

Schneider Electric warrants that the product shall be free from defects in materials and workmanship for a period of one year from the date of product start-up when start-up is performed by Schneider Electric-authorized service personnel and occurs within six months of the Schneider Electric shipment date. This warranty covers repairing or replacing any defective parts including on-site labor and travel. In the event that the product fails to meet the foregoing warranty criteria, the warranty covers repairing or replacing defective parts at the sole discretion of Schneider Electric for a period of one year from the shipment date. For Schneider Electric cooling solutions, this warranty does not cover circuit breaker resetting, loss of refrigerant, consumables, or preventive maintenance items. Repair or replacement of a defective product or part thereof does not extend the original warranty period. Any parts furnished under this warranty may be new or factory-remanufactured.

Non-transferable Warranty

This warranty is extended to the first person, firm, association or corporation (herein referred to by "You" or "Your") for whom the Schneider Electric product specified herein has been purchased. This warranty is not transferable or assignable without the prior written permission of Schneider Electric.

Assignment of Warranties

Schneider Electric will assign you any warranties which are made by manufacturers and suppliers of components of the Schneider Electric product and which are assignable. Any such warranties are assigned "AS IS" and Schneider Electric makes no representation as to the effectiveness or extent of such warranties, assumes no responsibility for any matters which may be warranted by such manufacturers or suppliers and extends no coverage under this Warranty to such components.

Drawings, Descriptions

Schneider Electric warrants for the warranty period and on the terms of the warranty set forth herein that the Schneider Electric product will substantially conform to the descriptions contained in the Schneider Electric Official Published Specifications or any of the drawings certified and agreed to by contract with Schneider Electric if applicable thereto ("Specifications"). It is understood that the Specifications are not warranties of performance and not warranties of fitness for a particular purpose.

Exclusions

Schneider Electric shall not be liable under the warranty if its testing and examination disclose that the alleged defect in the product does not exist or was caused by end user or any third person misuse, negligence, improper installation or testing. Further, Schneider Electric shall not be liable under the warranty for unauthorized attempts to repair or modify wrong or inadequate electrical voltage or connection, inappropriate on-site operation conditions, corrosive atmosphere, repair, installation, start-up by non-Schneider Electric designated personnel, a change in location or operating use, exposure to the elements, Acts of God, fire, theft, or installation contrary to Schneider Electric recommendations or specifications or in any event if the Schneider Electric serial number has been altered, defaced, or removed, or any other cause beyond the range of the intended use.

THERE ARE NO WARRANTIES, EXPRESS OR IMPLIED, BY OPERATION OF LAW OR OTHERWISE, OF PRODUCTS SOLD, SERVICED OR FURNISHED UNDER THIS AGREEMENT OR IN CONNECTION HEREWITH. SCHNEIDER ELECTRIC DISCLAIMS ALL IMPLIED WARRANTIES OF MERCHANTABILITY, SATISFACTION AND FITNESS FOR A PARTICULAR PURPOSE. SCHNEIDER ELECTRIC EXPRESS WARRANTIES WILL NOT BE ENLARGED, DIMINISHED, OR AFFECTED BY AND NO OBLIGATION OR LIABILITY WILL ARISE OUT OF, SCHNEIDER ELECTRIC RENDERING OF TECHNICAL OR OTHER ADVICE OR SERVICE IN CONNECTION WITH THE PRODUCTS. THE FOREGOING WARRANTIES AND REMEDIES ARE EXCLUSIVE AND IN LIEU OF ALL OTHER WARRANTIES AND REMEDIES. THE WARRANTIES SET FORTH ABOVE CONSTITUTE SCHNEIDER ELECTRIC SOLE LIABILITY AND PURCHASER'S EXCLUSIVE REMEDY FOR ANY BREACH OF SUCH WARRANTIES. SCHNEIDER ELECTRIC WARRANTIES RUN ONLY TO PURCHASER AND ARE NOT EXTENDED TO ANY THIRD PARTIES.

IN NO EVENT SHALL SCHNEIDER ELECTRIC, ITS OFFICERS, DIRECTORS, AFFILIATES OR EMPLOYEES BE LIABLE FOR ANY FORM OF INDIRECT, SPECIAL, CONSEQUENTIAL OR PUNITIVE DAMAGES, ARISING OUT OF THE USE, SERVICE OR INSTALLATION, OF THE PRODUCTS, WHETHER SUCH DAMAGES ARISE IN CONTRACT OR TORT, IRRESPECTIVE OF FAULT, NEGLIGENCE OR STRICT LIABILITY OR WHETHER SCHNEIDER ELECTRIC HAS BEEN ADVISED IN ADVANCE OF THE POSSIBILITY OF SUCH DAMAGES, SPECIFICALLY, SCHNEIDER ELECTRIC IS NOT LIABLE FOR ANY COSTS, SUCH AS LOST PROFITS OR REVENUE, LOSS OF EQUIPMENT, LOSS OF USE OF EQUIPMENT, LOSS OF SOFTWARE, LOSS OF DATA, COSTS OF SUBSTITUANTS, CLAIMS BY THIRD PARTIES, OR OTHERWISE.

NO SALESMAN, EMPLOYEE OR AGENT OF SCHNEIDER ELECTRIC IS AUTHORIZED TO ADD TO OR VARY THE TERMS OF THIS WARRANTY. WARRANTY TERMS MAY BE MODIFIED, IF AT ALL, ONLY IN WRITING SIGNED BY AN SCHNEIDER ELECTRIC OFFICER AND LEGAL DEPARTMENT.

Warranty Claims

Customers with warranty claims issues may access the SCHNEIDER ELECTRIC worldwide customer support network through the SCHNEIDER ELECTRIC web site: <http://www.schneider-electric.com>. Select your country from the country selection pull-down menu. Open the Support tab at the top of the web page to obtain contact information for customer support in your region.

Schneider Electric
35 rue Joseph Monier
92500 Rueil Malmaison
France

+ 33 (0) 1 41 29 70 00

www.se.com

As standards, specifications, and design change from time to time,
please ask for confirmation of the information given in this publication.

© 2021 – 2024 Schneider Electric. All rights reserved.

990-91399G-001