

Galaxy VL

Maintenance Bypass Cabinet for UL

Installation

GVLMBCA200K500G

Latest updates are available on the Schneider Electric website
5/2024



Legal Information

The information provided in this document contains general descriptions, technical characteristics and/or recommendations related to products/solutions.

This document is not intended as a substitute for a detailed study or operational and site-specific development or schematic plan. It is not to be used for determining suitability or reliability of the products/solutions for specific user applications. It is the duty of any such user to perform or have any professional expert of its choice (integrator, specifier or the like) perform the appropriate and comprehensive risk analysis, evaluation and testing of the products/solutions with respect to the relevant specific application or use thereof.

The Schneider Electric brand and any trademarks of Schneider Electric SE and its subsidiaries referred to in this document are the property of Schneider Electric SE or its subsidiaries. All other brands may be trademarks of their respective owner.

This document and its content are protected under applicable copyright laws and provided for informative use only. No part of this document may be reproduced or transmitted in any form or by any means (electronic, mechanical, photocopying, recording, or otherwise), for any purpose, without the prior written permission of Schneider Electric.

Schneider Electric does not grant any right or license for commercial use of the document or its content, except for a non-exclusive and personal license to consult it on an "as is" basis.

Schneider Electric reserves the right to make changes or updates with respect to or in the content of this document or the format thereof, at any time without notice.

To the extent permitted by applicable law, no responsibility or liability is assumed by Schneider Electric and its subsidiaries for any errors or omissions in the informational content of this document, as well as any non-intended use or misuse of the content thereof.

Table of Contents

Important Safety Instructions — SAVE THESE	
INSTRUCTIONS	5
Safety Precautions	6
Additional Safety Precautions After Installation.....	7
Electrical Safety	8
Battery Safety	9
Specifications	11
Maximum Short Circuit Rating	11
Trip Settings.....	11
Recommended Upstream Protection.....	11
Recommended Cable Sizes	11
Recommended Bolt and Lug Sizes for UL.....	12
Torque Specifications.....	13
Maintenance Bypass Cabinet Weights and Dimensions.....	13
Clearance	13
Environment.....	14
System Overview	15
Installation Procedure	16
Install the Seismic Anchoring (Option)	18
Prepare for Installation.....	20
Connect the Power Cables.....	26
Restrain the Cables.....	30
Interconnect the UPS with the Maintenance Bypass Cabinet.....	32
Prepare the UPS for Internal Busbar Connection	35
Install Busbars Between the UPS and the Maintenance Bypass Cabinet in Single Mains System.....	38
Install Busbars Between the UPS and the Maintenance Bypass Cabinet in Dual Mains System.....	40
Install Busbars for Load Bank Breaker (Option).....	43
Prepare for Signal Cables in Top Cable Entry Systems.....	44
Prepare for Signal Cables in Bottom Cable Entry Systems.....	45
Connect the Signal Cables Between the Maintenance Bypass Cabinet and the UPS.....	48
Add Translated Safety Labels to Your Product.....	51
Final Installation	52
Decommission or Move the Maintenance Bypass Cabinet to a New Location.....	53

Important Safety Instructions — SAVE THESE INSTRUCTIONS

Read these instructions carefully and look at the equipment to become familiar with it before trying to install, operate, service or maintain it. The following safety messages may appear throughout this manual or on the equipment to warn of potential hazards or to call attention to information that clarifies or simplifies a procedure.



The addition of this symbol to a “Danger” or “Warning” safety message indicates that an electrical hazard exists which will result in personal injury if the instructions are not followed.



This is the safety alert symbol. It is used to alert you to potential personal injury hazards. Obey all safety messages with this symbol to avoid possible injury or death.

DANGER

DANGER indicates a hazardous situation which, if not avoided, **will result in death or serious injury.**

Failure to follow these instructions will result in death or serious injury.

WARNING

WARNING indicates a hazardous situation which, if not avoided, **could result in death or serious injury.**

Failure to follow these instructions can result in death, serious injury, or equipment damage.

CAUTION

CAUTION indicates a hazardous situation which, if not avoided, **could result in minor or moderate injury.**

Failure to follow these instructions can result in injury or equipment damage.

NOTICE

NOTICE is used to address practices not related to physical injury. The safety alert symbol shall not be used with this type of safety message.

Failure to follow these instructions can result in equipment damage.

Please Note

Electrical equipment should only be installed, operated, serviced, and maintained by qualified personnel. No responsibility is assumed by Schneider Electric for any consequences arising out of the use of this material.

A qualified person is one who has skills and knowledge related to the construction, installation, and operation of electrical equipment and has received safety training to recognize and avoid the hazards involved.

Safety Precautions

DANGER

HAZARD OF ELECTRIC SHOCK, EXPLOSION, OR ARC FLASH

Read all instructions in the installation manual before installing or working on this product.

Failure to follow these instructions will result in death or serious injury.

DANGER

HAZARD OF ELECTRIC SHOCK, EXPLOSION, OR ARC FLASH

Do not install the product until all construction work has been completed and the installation room has been cleaned.

Failure to follow these instructions will result in death or serious injury.

DANGER

HAZARD OF ELECTRIC SHOCK, EXPLOSION, OR ARC FLASH

The product must be installed according to the specifications and requirements as defined by Schneider Electric. It concerns in particular the external and internal protections (upstream breakers, battery breakers, cabling, etc.) and environmental requirements. No responsibility is assumed by Schneider Electric if these requirements are not respected.

Failure to follow these instructions will result in death or serious injury.

DANGER

HAZARD OF ELECTRIC SHOCK, EXPLOSION, OR ARC FLASH

The UPS system must be installed according to local and national regulations. Install the UPS system according to:

- IEC 60364 (including 60364-4-41- protection against electric shock, 60364-4-42 - protection against thermal effect, and 60364-4-43 - protection against overcurrent), **or**
- NEC NFPA 70, **or**
- Canadian Electrical Code (C22.1, Part 1)

depending on which one of the standards apply in your local area.

Failure to follow these instructions will result in death or serious injury.

DANGER

HAZARD OF ELECTRIC SHOCK, EXPLOSION, OR ARC FLASH

- Install the product in a temperature controlled indoor environment free of conductive contaminants and humidity.
- Install the product on a non-flammable, level and solid surface (e.g. concrete) that can support the weight of the system.

Failure to follow these instructions will result in death or serious injury.

⚠️⚠️ DANGER

HAZARD OF ELECTRIC SHOCK, EXPLOSION, OR ARC FLASH

The product is not designed for and must therefore not be installed in the following unusual operating environments:

- Damaging fumes
- Explosive mixtures of dust or gases, corrosive gases, or conductive or radiant heat from other sources
- Moisture, abrasive dust, steam or in an excessively damp environment
- Fungus, insects, vermin
- Salt-laden air or contaminated cooling refrigerant
- Pollution degree higher than 2 according to IEC 60664-1
- Exposure to abnormal vibrations, shocks, and tilting
- Exposure to direct sunlight, heat sources, or strong electromagnetic fields

Failure to follow these instructions will result in death or serious injury.

⚠️⚠️ DANGER

HAZARD OF ELECTRIC SHOCK, EXPLOSION, OR ARC FLASH

Do not drill or cut holes for cables or conduits with the gland plates installed and do not drill or cut holes in close proximity to the UPS system.

Failure to follow these instructions will result in death or serious injury.

⚠️⚠️ WARNING

HAZARD OF ARC FLASH

Do not make mechanical changes to the product (including removal of cabinet parts or drilling/cutting of holes) that are not described in the installation manual.

Failure to follow these instructions can result in death, serious injury, or equipment damage.

NOTICE

RISK OF OVERHEATING

Respect the space requirements around the product and do not cover the ventilation openings when the product is in operation.

Failure to follow these instructions can result in equipment damage.

Additional Safety Precautions After Installation

⚠️⚠️ DANGER

HAZARD OF ELECTRIC SHOCK, EXPLOSION, OR ARC FLASH

Do not install the UPS system until all construction work has been completed and the installation room has been cleaned. If additional construction work is needed in the installation room after this product has been installed, turn off the product and cover the product with the protective packaging bag the product was delivered in.

Failure to follow these instructions will result in death or serious injury.

Electrical Safety

This manual contains important safety instructions that should be followed during the installation and maintenance of the UPS system.

DANGER

HAZARD OF ELECTRIC SHOCK, EXPLOSION, OR ARC FLASH

- Electrical equipment must be installed, operated, serviced, and maintained only by qualified personnel.
- Apply appropriate personal protective equipment (PPE) and follow safe electrical work practices.
- Disconnection devices for AC and DC must be provided by others, be readily accessible, and the function of the disconnect device marked for its function.
- Turn off all power supplying the UPS system before working on or inside the equipment.
- Before working on the UPS system, check for hazardous voltage between all terminals including the protective earth.
- The UPS contains an internal energy source. Hazardous voltage can be present even when disconnected from the mains supply. Before installing or servicing the UPS system, ensure that the units are OFF and that mains and batteries are disconnected. Wait five minutes before opening the UPS to allow the capacitors to discharge.
- The UPS must be properly earthed/grounded and due to a high leakage current, the earthing/grounding conductor must be connected first.

Failure to follow these instructions will result in death or serious injury.

The label below must be added if:

1. The UPS input is connected through external isolators that, when opened, isolate the neutral, OR
2. The UPS input is connected via an IT power system.

The label must be placed adjacent to all upstream power disconnection devices that isolate the neutral.

DANGER

HAZARD OF ELECTRIC SHOCK, EXPLOSION, OR ARC FLASH

Risk of voltage backfeed. Before working on this circuit: Isolate the UPS and check for hazardous voltage between all terminals including the protective earth.

Failure to follow these instructions will result in death or serious injury.

Battery Safety

DANGER

HAZARD OF ELECTRIC SHOCK, EXPLOSION, OR ARC FLASH

- Battery circuit breakers must be installed according to the specifications and requirements as defined by Schneider Electric.
- Servicing of batteries must only be performed or supervised by qualified personnel knowledgeable of batteries and the required precautions. Keep unqualified personnel away from batteries.
- Disconnect charging source prior to connecting or disconnecting battery terminals.
- Do not dispose of batteries in a fire as they can explode.
- Do not open, alter, or mutilate batteries. Released electrolyte is harmful to the skin and eyes. It may be toxic.

Failure to follow these instructions will result in death or serious injury.

DANGER

HAZARD OF ELECTRIC SHOCK, EXPLOSION, OR ARC FLASH

Batteries can present a risk of electric shock and high short-circuit current. The following precautions must be observed when working on batteries

- Remove watches, rings, or other metal objects.
- Use tools with insulated handles.
- Wear protective glasses, gloves and boots.
- Do not lay tools or metal parts on top of batteries.
- Disconnect the charging source prior to connecting or disconnecting battery terminals.
- Determine if the battery is inadvertently grounded. If inadvertently grounded, remove source from ground. Contact with any part of a grounded battery can result in electric shock. The likelihood of such shock can be reduced if such grounds are removed during installation and maintenance (applicable to equipment and remote battery supplies not having a grounded supply circuit).

Failure to follow these instructions will result in death or serious injury.

DANGER

HAZARD OF ELECTRIC SHOCK, EXPLOSION, OR ARC FLASH

When replacing batteries, always replace with the same type and number of batteries or battery packs.

Failure to follow these instructions will result in death or serious injury.

▲ CAUTION**RISK OF EQUIPMENT DAMAGE**

- Mount the batteries in the UPS system, but do not connect the batteries until the UPS system is ready to be powered up. The time duration from battery connection until the UPS system is powered up must not exceed 72 hours or 3 days.
- Batteries must not be stored more than six months due to the requirement of recharging. If the UPS system remains de-energized for a long period, we recommend that you energize the UPS system for a period of 24 hours at least once every month. This charges the batteries, thus avoiding irreversible damage.

Failure to follow these instructions can result in injury or equipment damage.

Specifications

Maximum Short Circuit Rating

The maximum short circuit rating for the maintenance bypass cabinet is 65 kA RMS symmetrical Icc.

⚠ CAUTION
<p>HAZARD OF CABLE MOVEMENT IN SHORT CIRCUIT CONDITIONS</p> <p>In systems over 35 kAIC it is mandatory to restrain the power cables:</p> <ul style="list-style-type: none"> • Use 10 mm nylon rope or rope with a minimum tensile strength of 1000 kg (2204.62 lbs). <p>Failure to follow these instructions can result in injury or equipment damage.</p>

Trip Settings

NOTE: The power cables for 200-300 kW must be sized for 350 kW for SSIB/ UOB because the minimum Ir setting for PJF36120CU33A is 0.4.

UPS rating	Breaker type	UIB					SSIB/MBB/UOB				
		Ir	tr	Isd	tsd	li	Ir	tr	Isd	tsd	li
200 kW	PJF36120CU33A	0.4	1	1.5	Off	6	0.4	0.5	1.5	Off	6
250 kW	PJF36120CU33A	0.4	1	1.5	Off	6	0.4	0.5	1.5	Off	6
300 kW	PJF36120CU33A	0.4	1	1.5	Off	6	0.4	0.5	1.5	Off	6
350 kW	PJF36120CU33A	0.5	1	1.5	Off	6	0.4	0.5	1.5	Off	6
400 kW	PJF36120CU33A	0.5	1	1.5	Off	6	0.4	0.5	1.5	Off	6
450 kW	PJF36120CU33A	0.6	1	1.5	Off	6	0.5	0.5	1.5	Off	6
500 kW	PJF36120CU33A	0.7	1	1.5	Off	6	0.5	0.5	1.5	Off	6

Recommended Upstream Protection

Refer to the UPS installation manual for recommended upstream protection.

Recommended Cable Sizes

⚡⚠ DANGER
<p>HAZARD OF ELECTRIC SHOCK, EXPLOSION, OR ARC FLASH</p> <p>All wiring must comply with all applicable national and/or electrical codes. The maximum allowable cable size is 500 kcmil.</p> <p>Failure to follow these instructions will result in death or serious injury.</p>

Refer to the UPS installation manual for recommended cable sizes.

Recommended Bolt and Lug Sizes for UL

NOTICE

RISK OF EQUIPMENT DAMAGE

Use only UL approved compression cable lugs.

Failure to follow these instructions can result in equipment damage.

Copper

Cable size	Bolt size	Cable lug type (one hole)	Cable lug type (two hole NEMA)	Crimping tool	Die
1/0 AWG	M10x35mm	LCB1/0-12-X	LCC1/0-12-X	CT-930	CD-920-1/0 Pink P42
2/0 AWG	M10x35mm	LCB2/0-12-X	LCC2/0-12-X	CT-930	CD-920-2/0 Black P45
3/0 AWG	M10x35mm	LCB3/0-12-X	LCC3/0-12-X	CT-930	CD-920-3/0 Orange P50
4/0 AWG	M10x35mm	LCB4/0-12-X	LCC4/0-12-X	CT-930	CD-920-4/0 Purple P54
250 kcmil	M10x35mm	LCB250-12-X	LCC250-12-X	CT-930	CD-920-250 Yellow P62
300 kcmil	M10x35mm	LCB300-12-X	LCC300-12-X	CT-930	CD-920-300 Red P66
350 kcmil	M10x35mm	LCB350-12-X	LCC350-12-X	CT-930	CD-920-350 Red P71
400 kcmil	M10x35mm	LCB400-12-X	LCC400-12-6	CT-930	CD-920-400 Blue P76
450 kcmil	M10x35mm	—	LCC450-12-6	CT-930	—
500 kcmil	M10x35mm	LCB500-12-X	LCC500-12-6	CT-930	CD-920-500 Blue P87

Aluminum

Cable size	Bolt size	Cable lug type (one hole)	Cable lug type (two hole NEMA)	Crimping tool	Die
1/0 AWG	M10x35mm	LAA1/0-12-5	LAB1/0-12-X	CT-930	CD-920-1/0 Pink P42
2/0 AWG	M10x35mm	LAA2/0-12-5	LAB2/0-12-5	CT-930	CD-920-2/0 Black P45
3/0 AWG	M10x35mm	LAA3/0-12-5	LAB3/0-12-5	CT-930	CD-920-3/0 Orange P50
4/0 AWG	M10x35mm	LAA4/0-12-5	LAB4/0-12-5R	CT-930	CD-920-4/0 Purple P54
250 kcmil	M10x35mm	LAA250-12-5	LAB250-12-5	CT-930	CD-920-250 Yellow P62
300 kcmil	M10x35mm	LAA300-12-2	LAB300-12-2	CT-930	CD-920-300 Red P66
350 kcmil	M10x35mm	LAA350-12-2	LAB350-12-2R	CT-930	CD-920-350 Red P71
400 kcmil	M10x35mm	—	LAB400-12-2	CT-930	CD-920-400 Blue P76
500 kcmil	M10x35mm	LAA500-12-2	LAB500-12-2R	CT-930	CD-920-500 Blue P87

Torque Specifications

Bolt size	Torque
M6	5 Nm (3.69 lb-ft / 44.3 lb-in)
M8	17.5 Nm (12.91 lb-ft / 154.9 lb-in)
M10	30 Nm (22 lb-ft / 194.7 lb-in)
M12	50 Nm (36.87 lb-ft / 442.5 lb-in)

Maintenance Bypass Cabinet Weights and Dimensions

Commercial reference	Weight kg (lbs)	Height mm (in)	Width mm (in)	Depth mm (in)
GVLMBCA200K500G	158 (348)	1970 (77.55)	500 (19.68)	847 (33.34)

Clearance

NOTE: Clearance dimensions are published for airflow and service access only. Consult with the local safety codes and standards for additional requirements in your local area.

Front View of the Maintenance Bypass Cabinet and the UPS

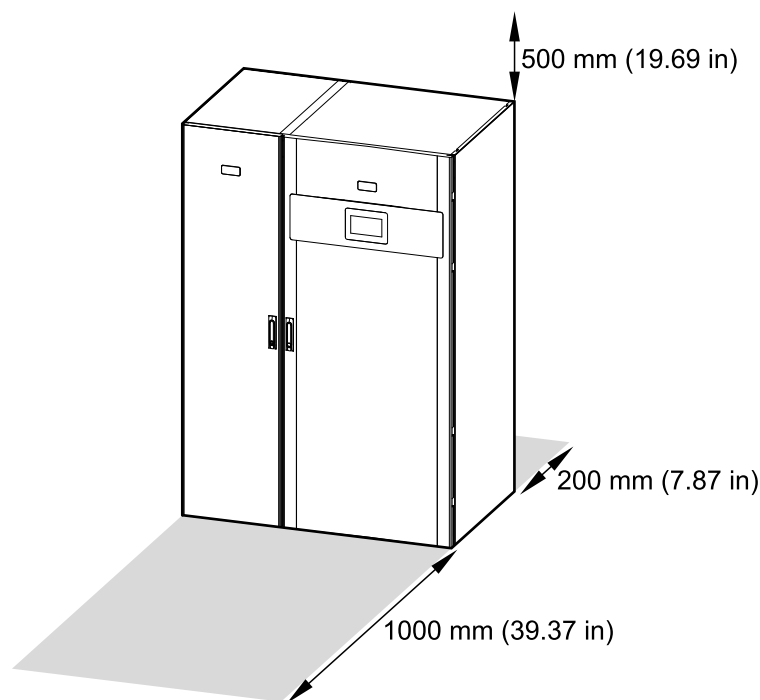

Environment

	Operating	Storage
Temperature	0 °C to 40 °C (32 °F to 104 °F)	-25 °C to 55 °C (-13 °F to 131 °F)
Relative humidity	5-95% non-condensing	10-80% non-condensing
Protection class	IP20	
Color	RAL 9003, gloss level 85%	

System Overview

UIB	Unit input breaker
SSIB	Static switch input breaker
MBB	Maintenance bypass breaker
UOB	Unit output breaker

Single Mains UPS System

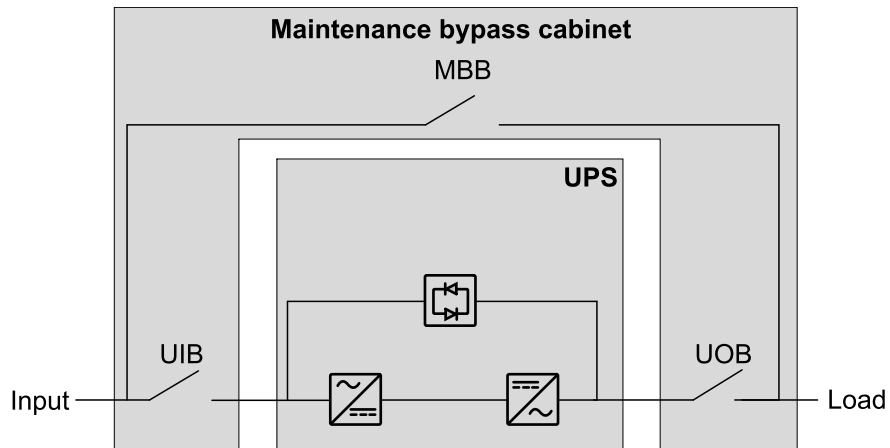

Dual Mains UPS System

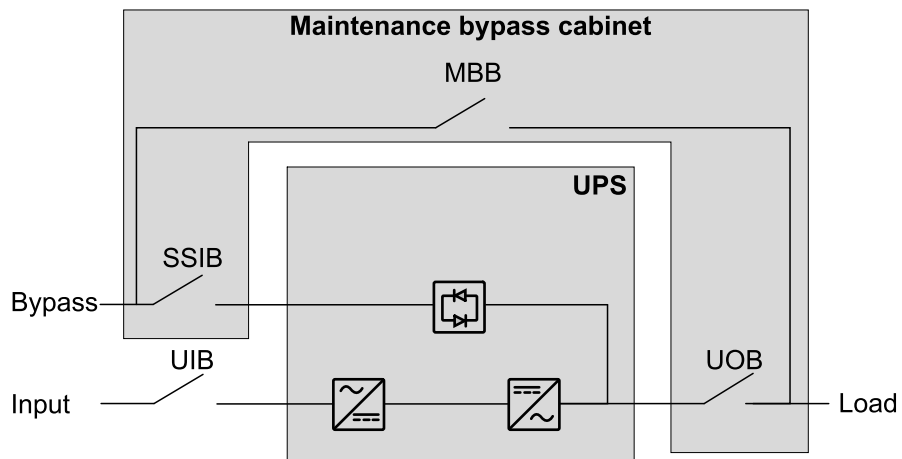

Installation Procedure

Single Mains – Top Entry

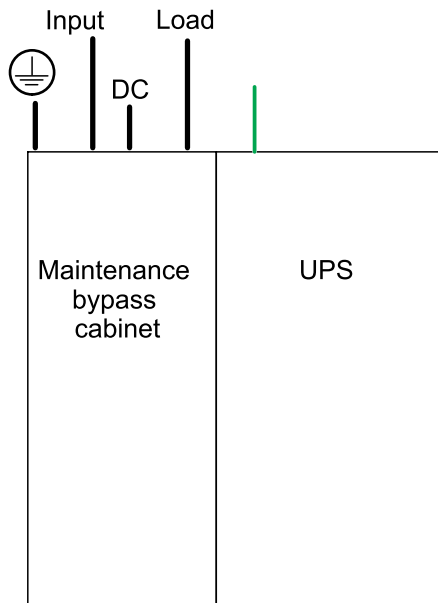

Dual Mains – Top Entry

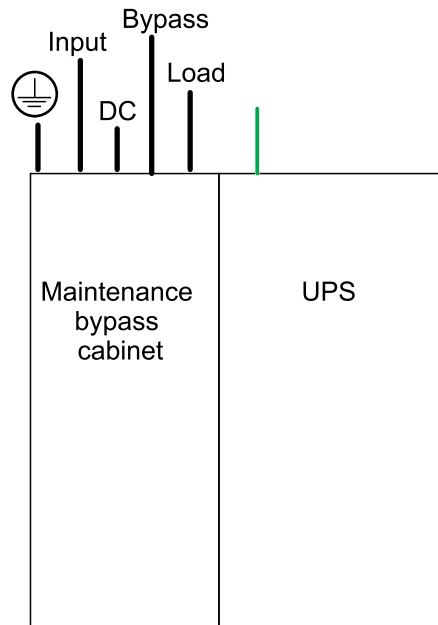

Single Mains – Bottom Entry

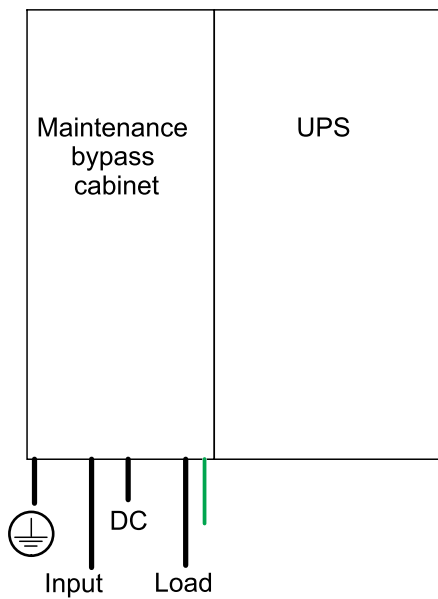

Dual Mains – Bottom Entry

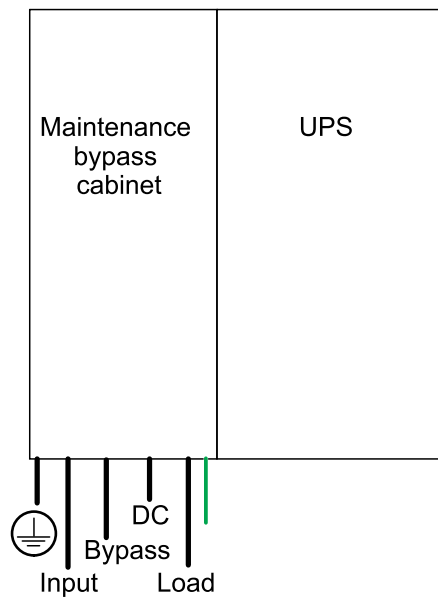

— Signal cable
 — Power cable

1. Install the Seismic Anchoring (Option), page 18.
2. Prepare for Installation, page 20.
3. Connect the Power Cables, page 26.
4. Interconnect the UPS with the Maintenance Bypass Cabinet, page 32.
5. Prepare the UPS for Internal Busbar Connection, page 35.

6. Connect the busbars between the UPS and the maintenance bypass cabinet. Perform one of the following procedures:
 - Install Busbars Between the UPS and the Maintenance Bypass Cabinet in Single Mains System, page 38, or
 - Install Busbars Between the UPS and the Maintenance Bypass Cabinet in Dual Mains System, page 40.
7. Install Busbars for Load Bank Breaker (Option), page 43.
8. Prepare for signal cabling. Perform one of the following procedures:
 - Prepare for Signal Cables in Top Cable Entry Systems, page 44, or
 - Prepare for Signal Cables in Bottom Cable Entry Systems, page 45.
9. Connect the Signal Cables Between the Maintenance Bypass Cabinet and the UPS, page 48.
10. Follow the UPS installation manual and other auxiliary product installation manuals to connect relevant signal cables and external communication cables in the UPS.
11. Add Translated Safety Labels to Your Product, page 51.
12. Final Installation, page 52.

For moving or decommissioning the maintenance bypass cabinet after installation has been completed, please see [Decommission or Move the Maintenance Bypass Cabinet to a New Location](#), page 53.

Install the Seismic Anchoring (Option)

Use the optional seismic kit GVLOPT002 for this procedure.

1. Connect the rear anchoring assemblies for the UPS and the maintenance bypass cabinet with the interconnection plate.

Rear View

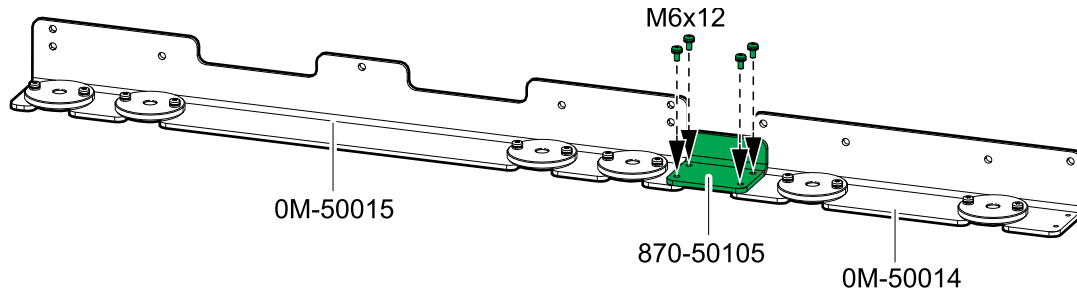

2. Mount the rear anchoring assembly to the floor. Use appropriate hardware for the floor type – the hole diameter in the rear anchors is $\varnothing 16$ mm. Minimum requirement is M12 strength grade 8.8 hardware.

Rear View

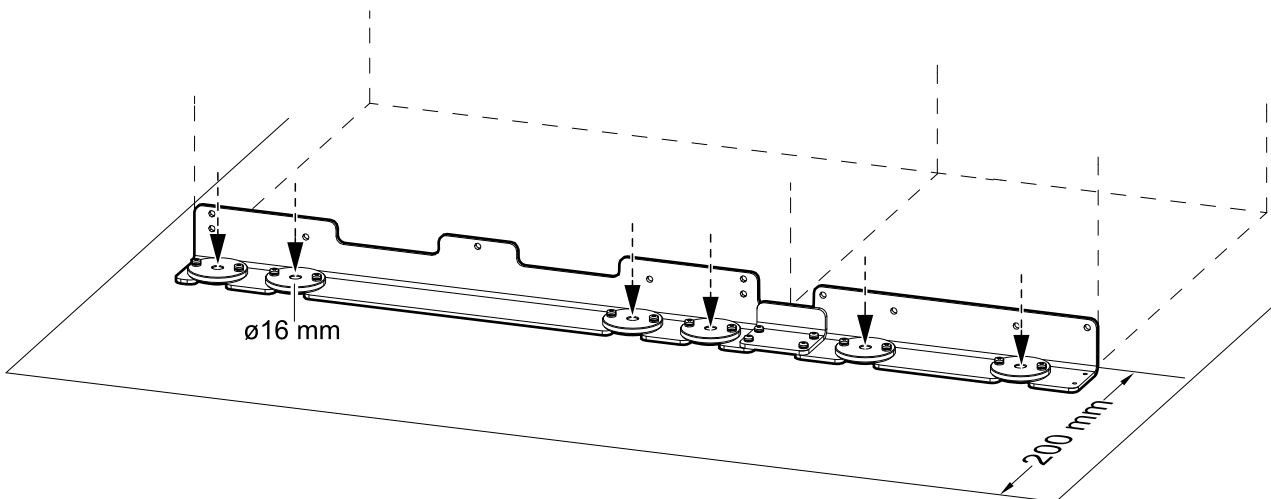

3. Remove all the screws and the interconnection plate.

Rear View

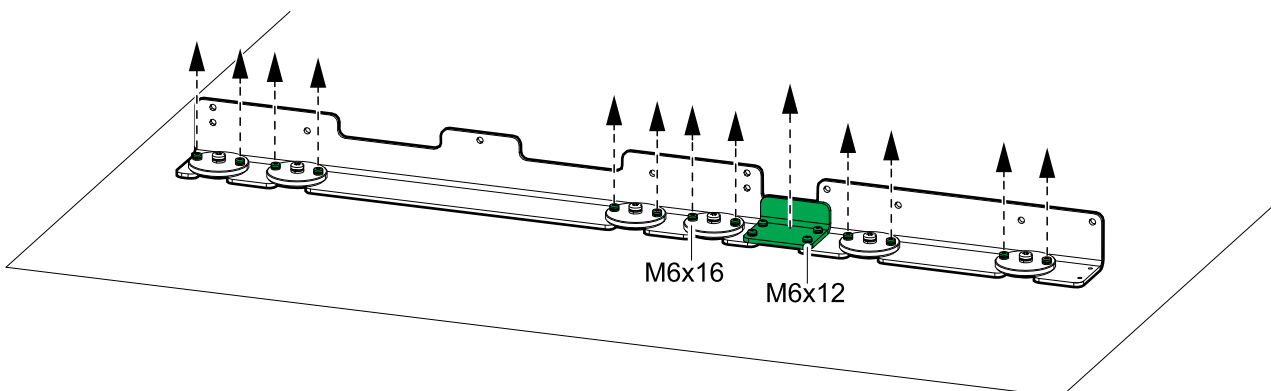

4. Remove the rear anchoring brackets.

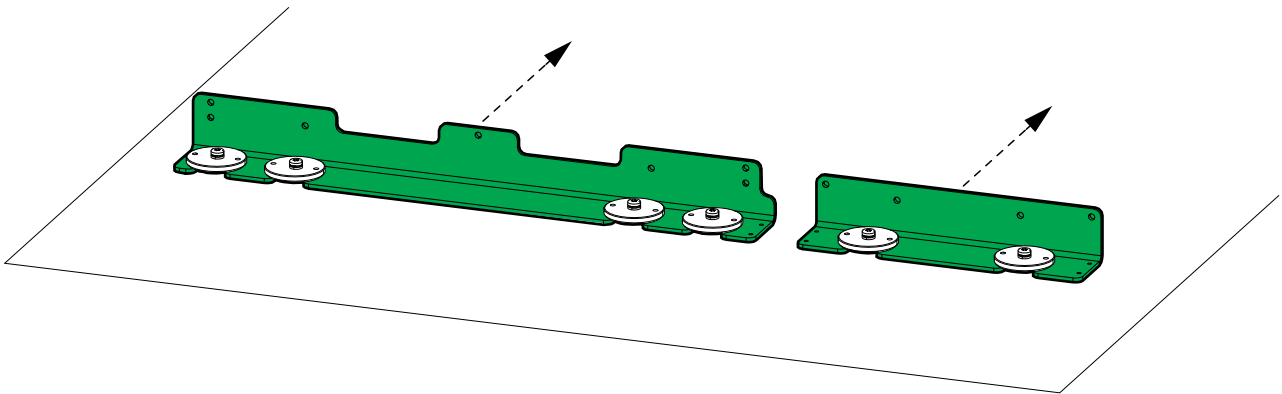
Rear View

5. Install the rear anchoring brackets on the UPS and the maintenance bypass cabinet with the provided bolts.

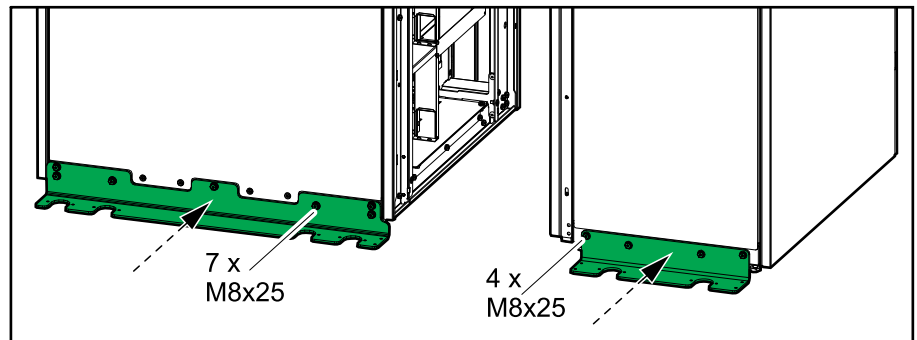
Rear View of the UPS and the Maintenance Bypass Cabinet

Prepare for Installation

1. Remove the brackets (A) and (B) from the maintenance bypass cabinet. Install the brackets (A) on the rear of the maintenance bypass cabinet. Save the bracket (B) for top interconnection with the UPS.

Right Side View of the Maintenance Bypass Cabinet

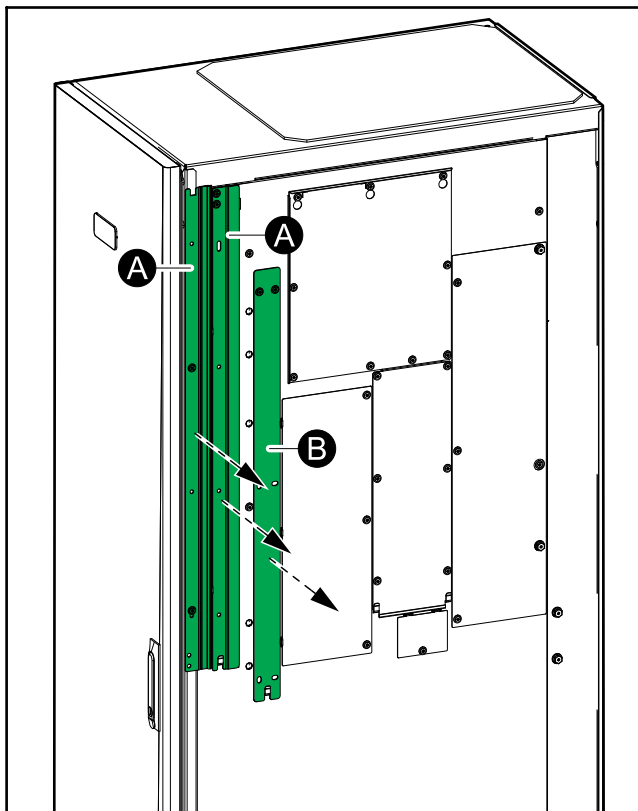

Rear View of the Maintenance Bypass Cabinet

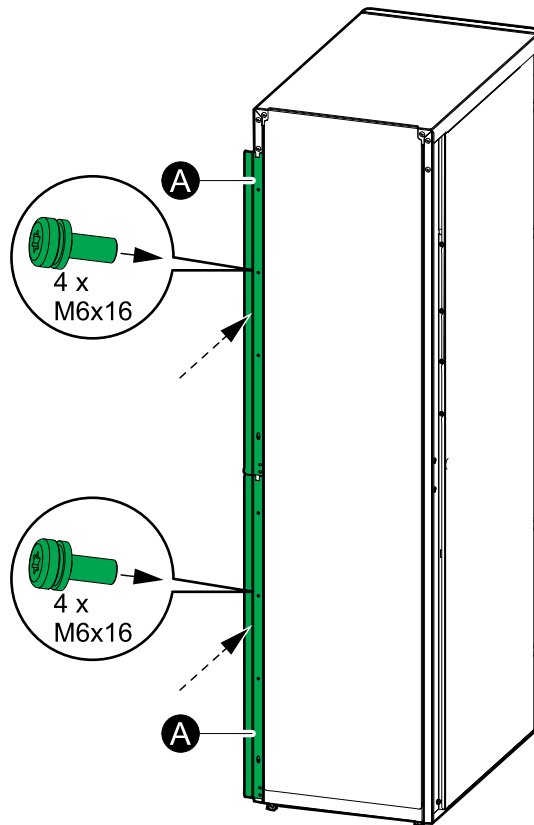

2. Remove the right side panel from the maintenance bypass cabinet.

The Maintenance Bypass Cabinet

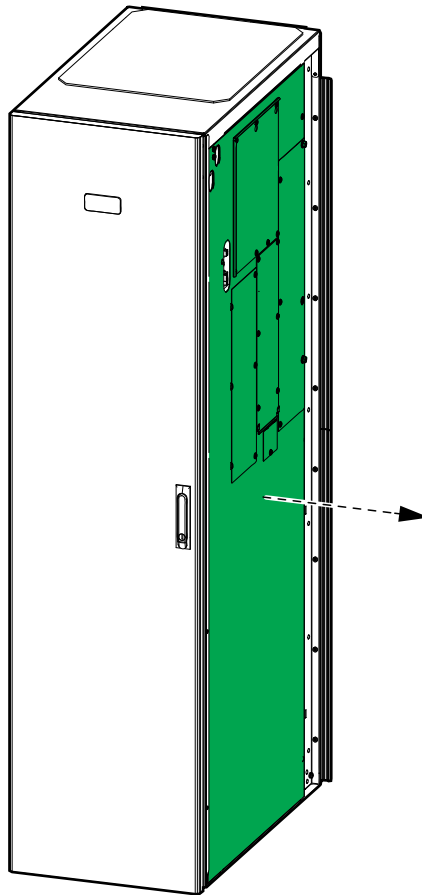

3. Remove the left side panel from the UPS. Install the left side panel on the maintenance bypass cabinet.

The Maintenance Bypass Cabinet and the UPS

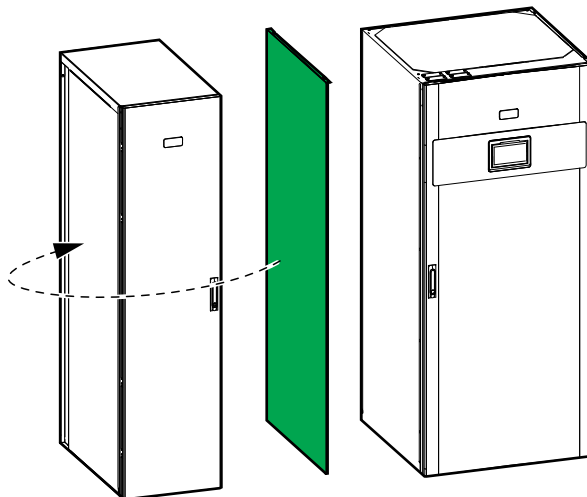

4. Push the maintenance bypass cabinet into final position. Align with seismic anchoring, if present. For systems without seismic anchoring, reinstall the rear transportation bracket on the maintenance bypass cabinet and mount it to the floor.

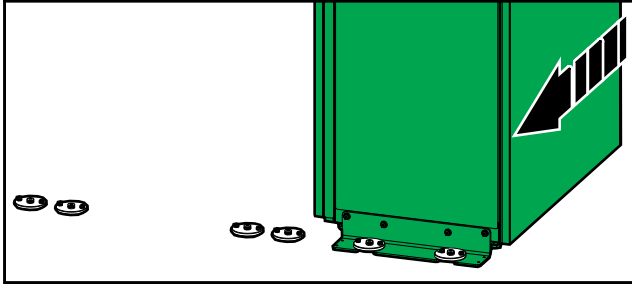
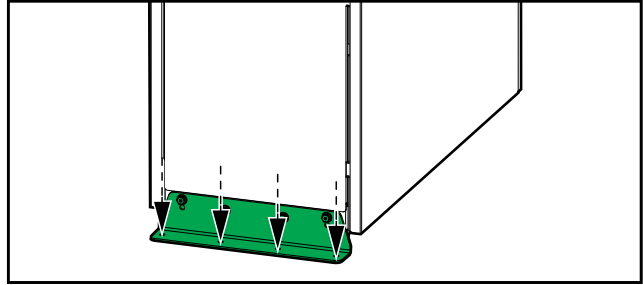
Rear View with Seismic Anchoring**Rear View without Seismic Anchoring**

5. Prepare for power cables:
 - a. Remove the top or bottom gland plate.
 - b. For bottom cable entry, remove the rear caster and the caster screws from the bottom gland plate. Discard the caster.
 - c. Drill or punch holes for power cables or conduits in the gland plate. Conduits are not provided.
 - d. Reinstall the top or bottom gland plate.

⚡ ⚠ DANGER**HAZARD OF ELECTRIC SHOCK, EXPLOSION, OR ARC FLASH**

Do not drill or punch holes with the gland plates installed and do not drill or punch holes in close proximity to the cabinet.

Failure to follow these instructions will result in death or serious injury.

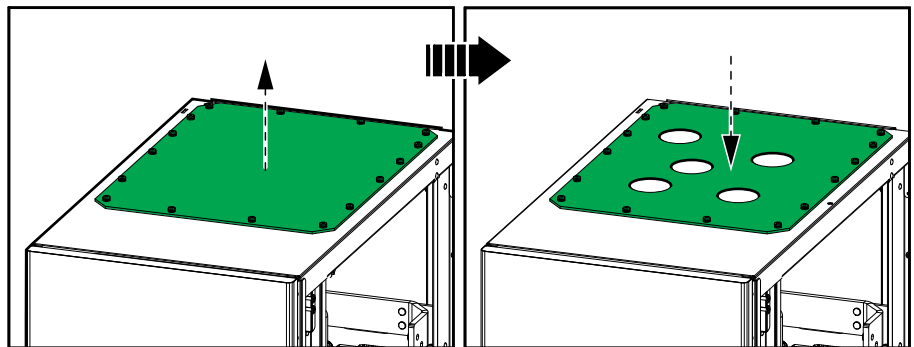
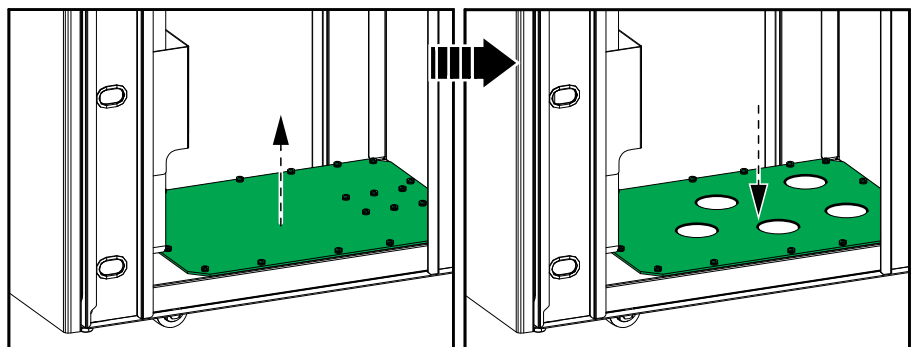
Top Cable Entry**Bottom Cable Entry**

6. Open the inner door on the UPS.

- Remove the transparent protection covers (marked (A) on the illustration) from the UPS.

NOTE: On older UPS models, the plastic box (marked (B) on the illustration) is present on the shelf and will need modification described in later instructions. On newer UPS models, the box (marked (C) on the illustration) is integrated in the inner door of the UPS instead of being a separate part. The integrated box must not be removed from the inner door. The integrated box does not need modification.

Front View of the UPS Model with Separate Plastic Box

Front View of the UPS Model with the Box Integrated in the Inner Door

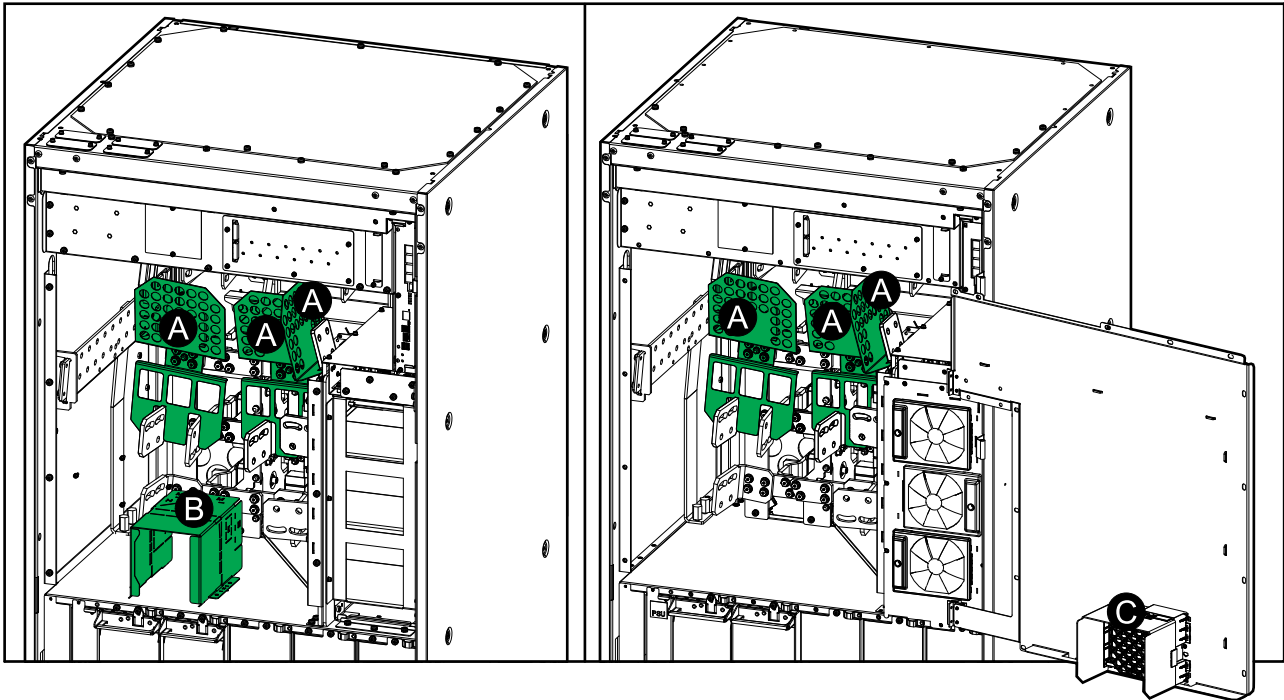

8. Remove busbars from the UPS. Some of the busbars will be installed in the maintenance bypass cabinet:
 - a. Remove the three busbars from the UPS. Install the three busbars in the maintenance bypass cabinet with the nine provided M8 nuts with washer (provided in kit). If the M8 nuts with washer are not in the provided kit, new M8 nuts with washer must be locally sourced and used.
 - b. Remove the three busbars from the UPS. **Only for dual mains:** Install the three busbars in the maintenance bypass cabinet with the 12 provided M8 nuts with washer (provided in kit). If the M8 nuts with washer are not in the provided kit, new M8 nuts with washer must be locally sourced and used.
 - c. Remove the three busbars from the UPS. Save for load bank breaker (LBB) option if this is part of the system.
 - d. Remove the four busbars from the UPS. Discard or save for spare parts.

Front View of the UPS

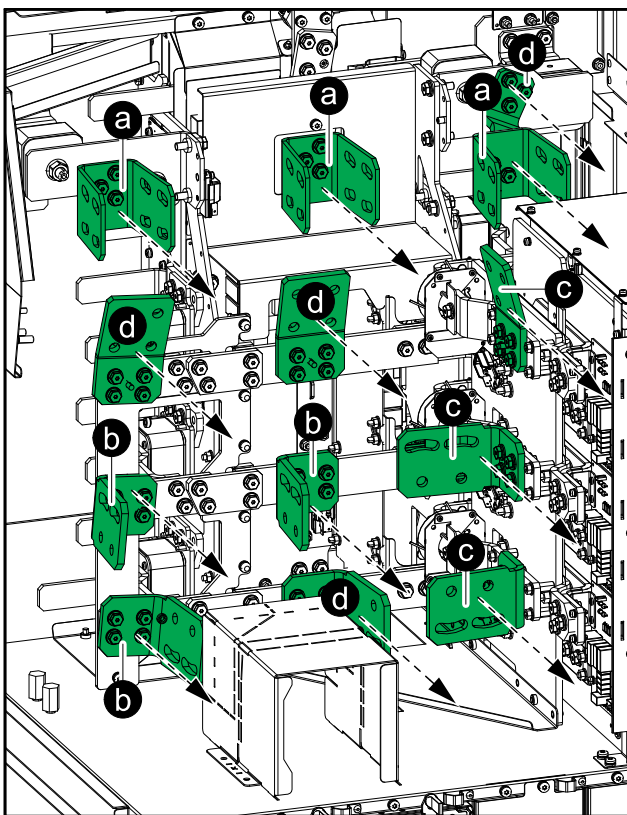

Front View of the Maintenance Bypass Cabinet

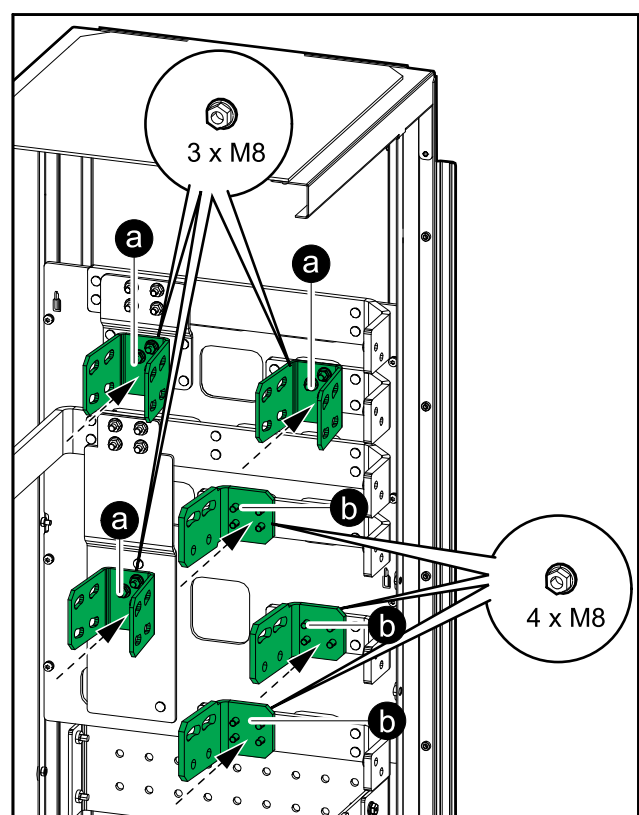

Connect the Power Cables

⚠ CAUTION

HAZARD OF CABLE MOVEMENT IN SHORT CIRCUIT CONDITIONS

In systems over 35 kAIC it is mandatory to restrain the power cables:

- Use 10 mm nylon rope or rope with a minimum tensile strength of 1000 kg (2204.62 lbs).

Failure to follow these instructions can result in injury or equipment damage.

1. Route the power cables through the top or bottom of the maintenance bypass cabinet.
2. Connect the EGC (Equipment Grounding Conductor), input cables, bypass cables (in dual mains systems), load cables, and DC cables. Assemble the cable lugs to the busbars as shown.

Single Mains

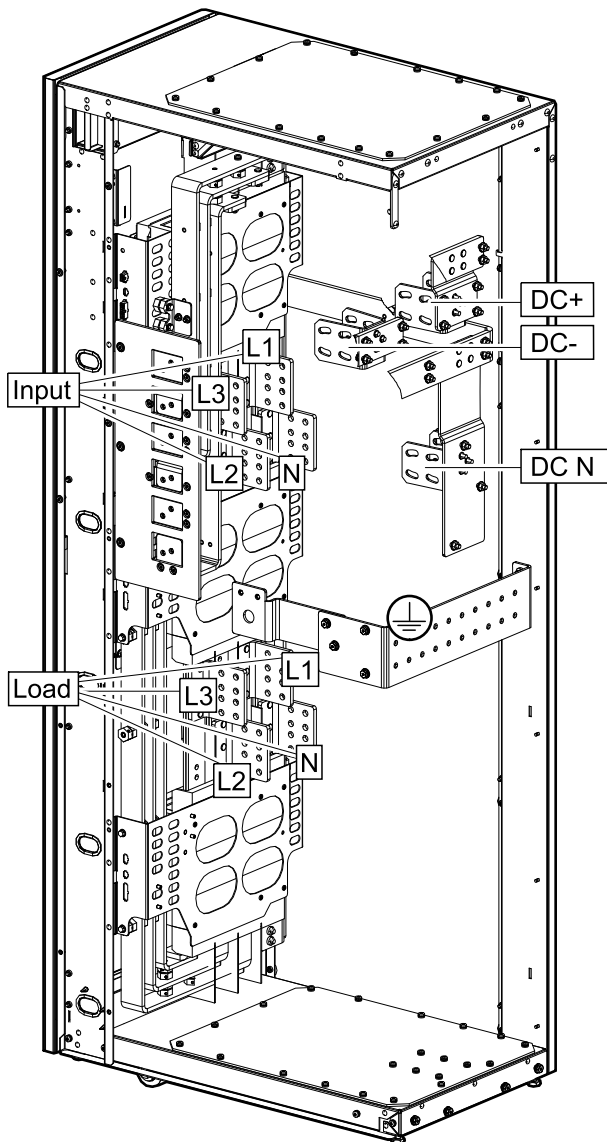

Dual Mains

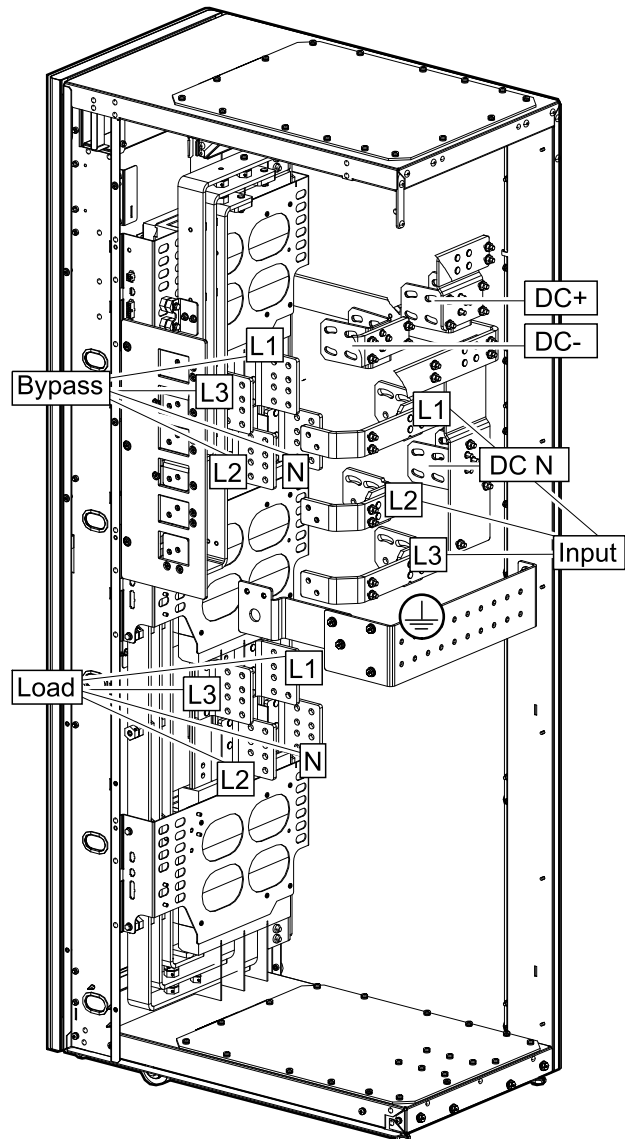

Cable Lug to Busbar Assembly

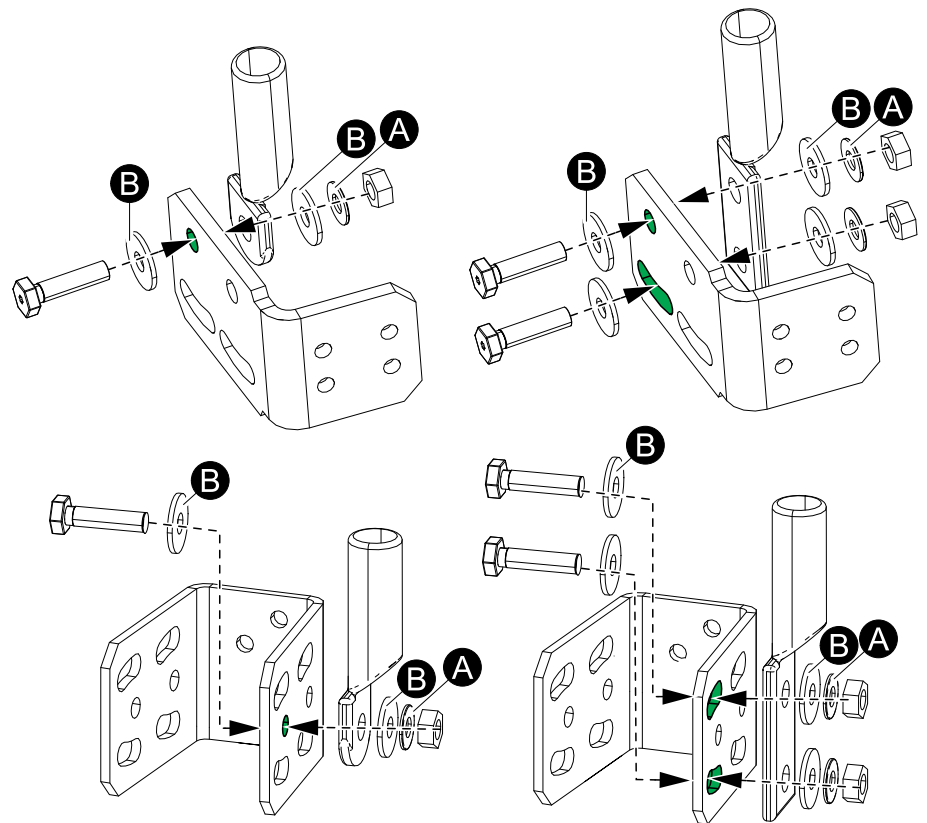

- A. Spring washer – provided in kit.
- B. Flat washer (not provided).

- Mandatory in systems over 35 kAIC:** Tie the power cables together at 250 mm (9.84 in) from the power cable terminals and at each 250 mm (9.84 in) interval. Wrap the rope around the power cables five times before tying a knot at each interval – see *Restrain the Cables*, page 30 for guidance.

Side View – Top Cable Entry

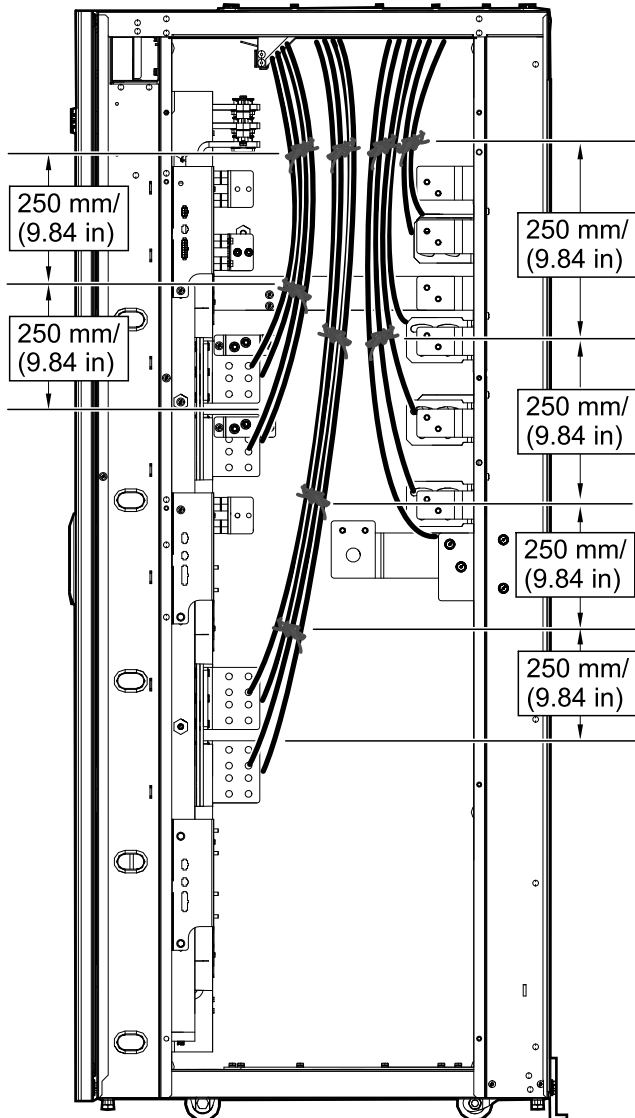

Side View – Bottom Cable Entry

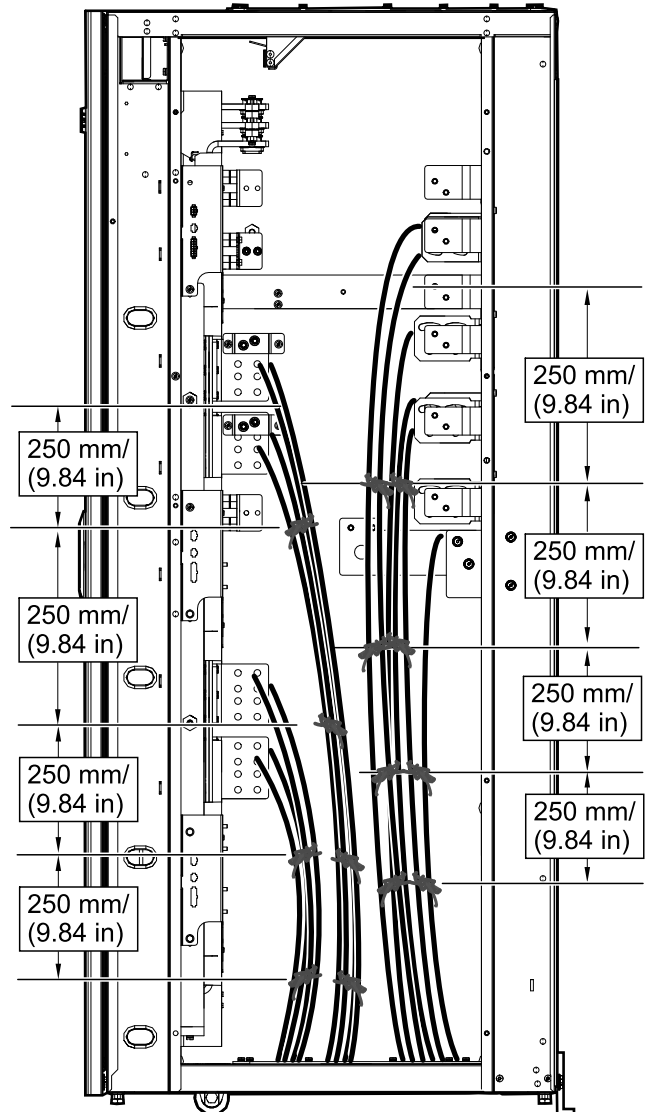

- Check the fastening of the cable lugs.

<p>▲ CAUTION</p>
<p>RISK OF EQUIPMENT DAMAGE</p> <p>Check the fastening of the cable lugs. If the cable lugs move due to pulling on cables, the bolt can become loose.</p> <p>Failure to follow these instructions can result in injury or equipment damage.</p>

- Clean/vacuum the maintenance bypass cabinet of any debris and foreign objects.

6. Reinstall the right side panel on the maintenance bypass cabinet.

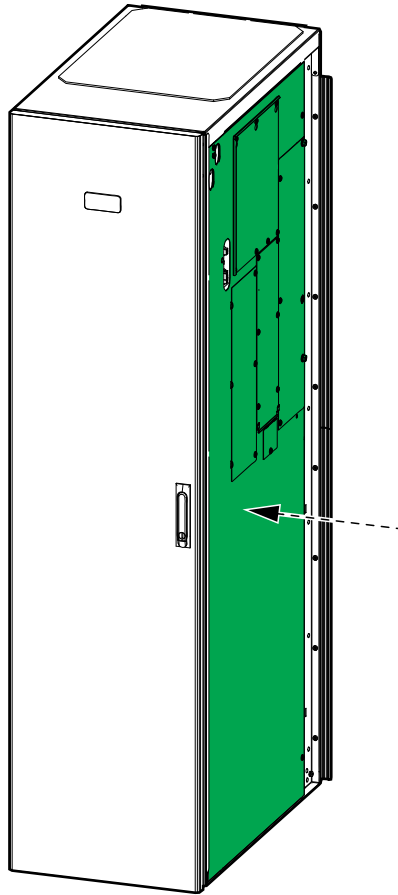

7. Reposition the protection covers on the right side panel. Reuse the M6 screws.

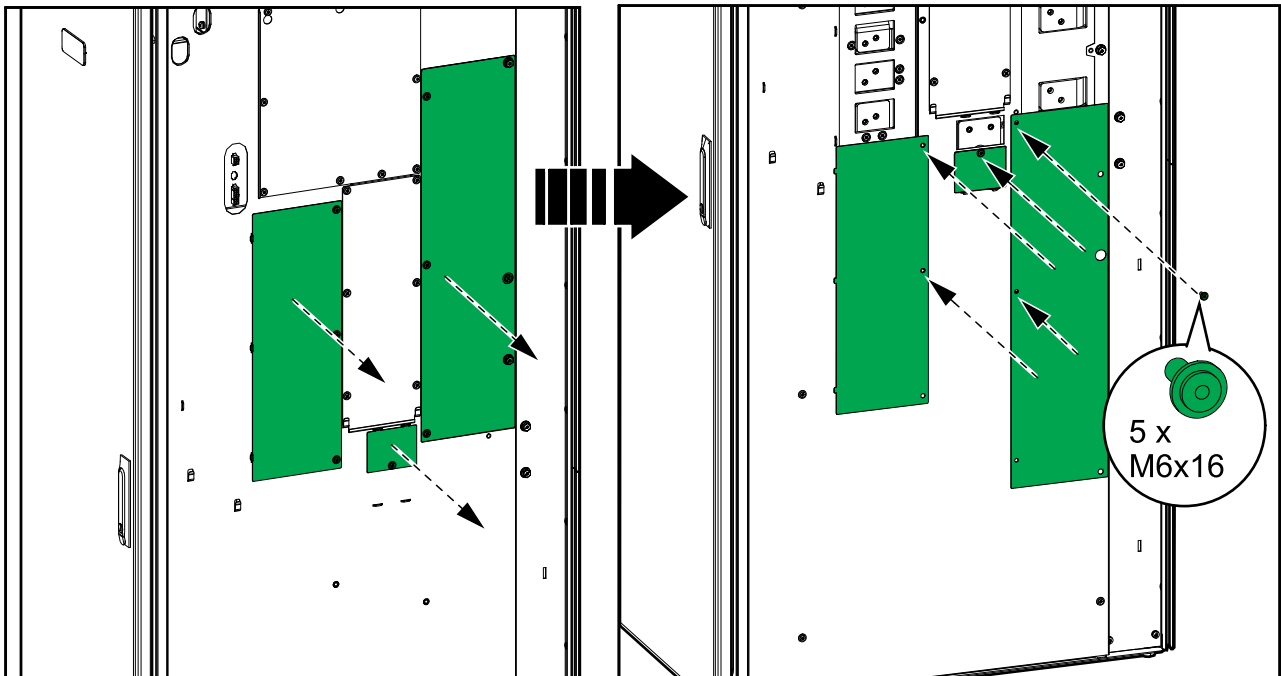

Restrain the Cables

Use 3/8 in nylon rope to restrain the cables.

1. Wrap the rope around the cables (a). Wrap the cables four times leaving 1 m (3 ft) of excess rope at the first end (b). Pull rope (c) taut.

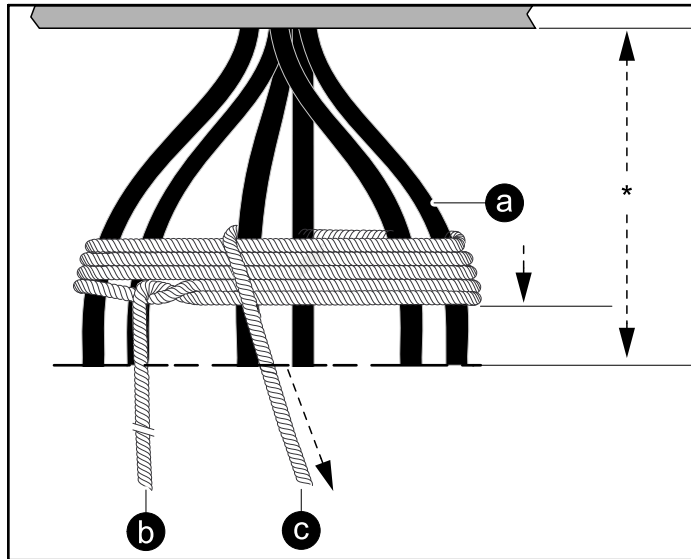

* Unsupported cable length.

2. Wrap rope (a) several times until the space between the first two sets of cables is completely filled. Weave final rope loop underneath the previous loop (b). Bring rope (c) through the other open area and pull the rope taut.

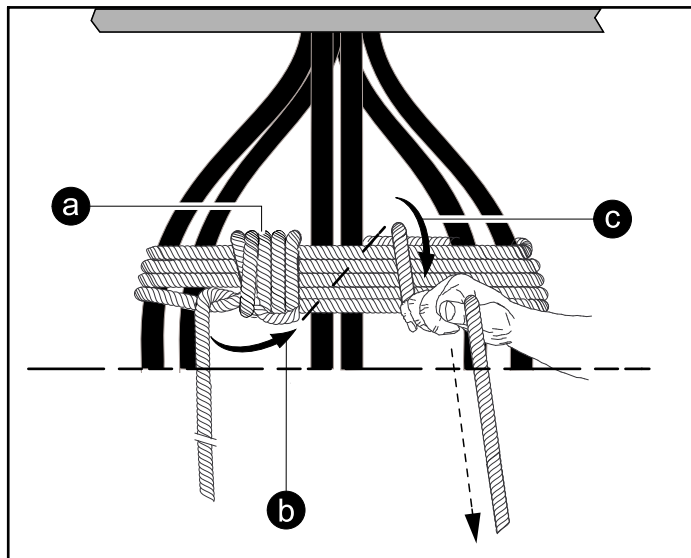

3. Wrap rope (a) several times until the space between the second and the third set of cables is completely filled. Wave the final rope loop (b) underneath the previous loop as shown. Pull the rope taut.

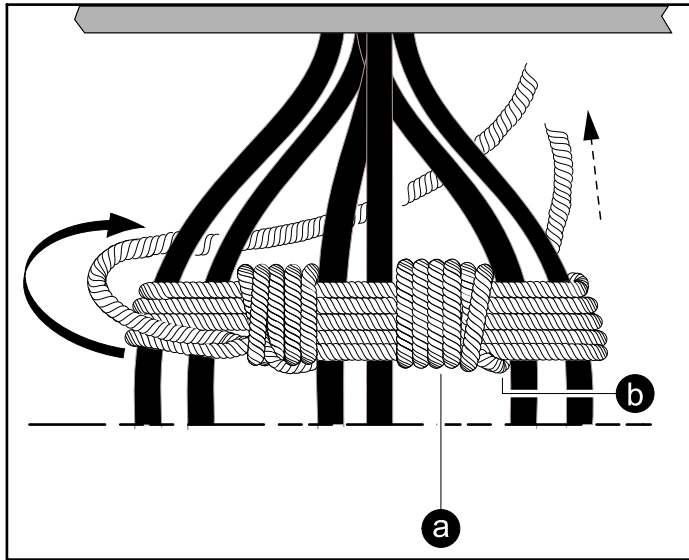

4. Tie rope End 1 and End 2 together as shown. The rope must be taut. Cut off excess rope and tape ends to prevent fraying.

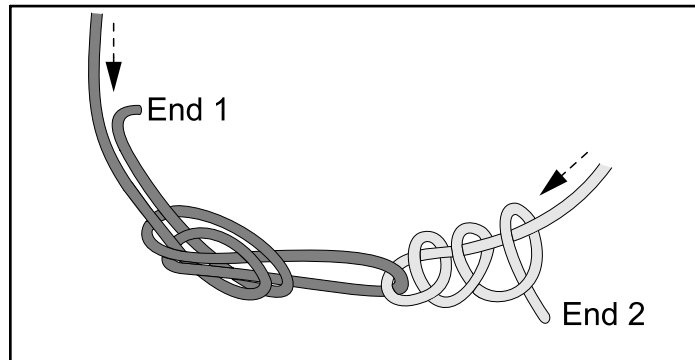

5. Repeat the procedure where needed.

Interconnect the UPS with the Maintenance Bypass Cabinet

1. Push the UPS into position next to the maintenance bypass cabinet. Align with seismic anchoring, if present.
2. Lower the front and rear leveling feet on the maintenance bypass cabinet and on the UPS with a wrench until they connect with the floor. The casters must not have contact with the floor. Use a bubble-leveler to check that the cabinet is level.

NOTICE

RISK OF EQUIPMENT DAMAGE

Do not move the cabinet after the leveling feet have been lowered.

Failure to follow these instructions can result in equipment damage.

3. Interconnect the maintenance bypass cabinet and the UPS in the front with screws as shown

4. Install the top bracket. The top bracket was removed from the side of the maintenance bypass cabinet earlier.

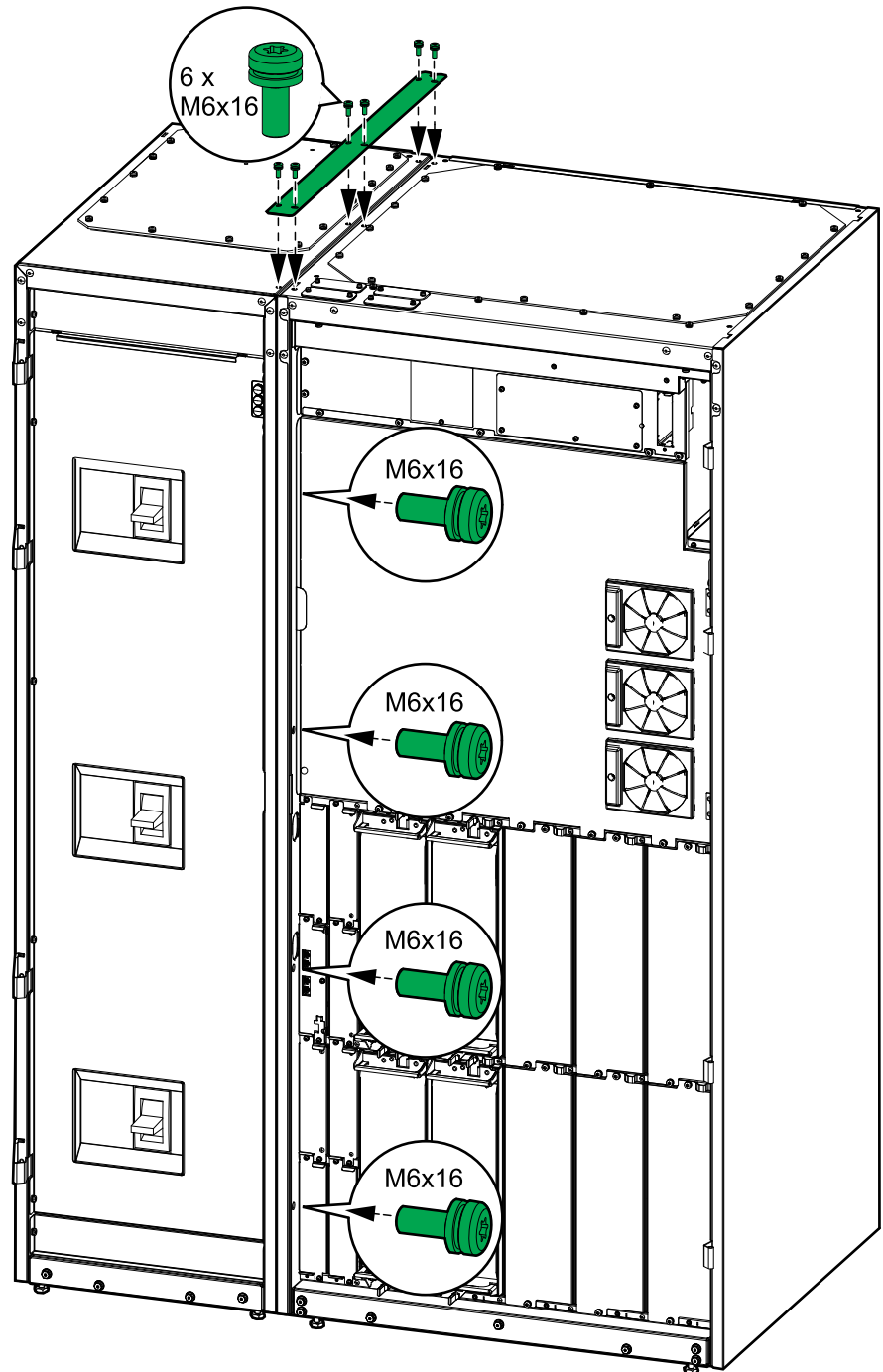

5. Open the inner door in the UPS.

6. Remove the two special screws from the UPS and use for rear interconnection between the maintenance bypass cabinet and the UPS as shown.

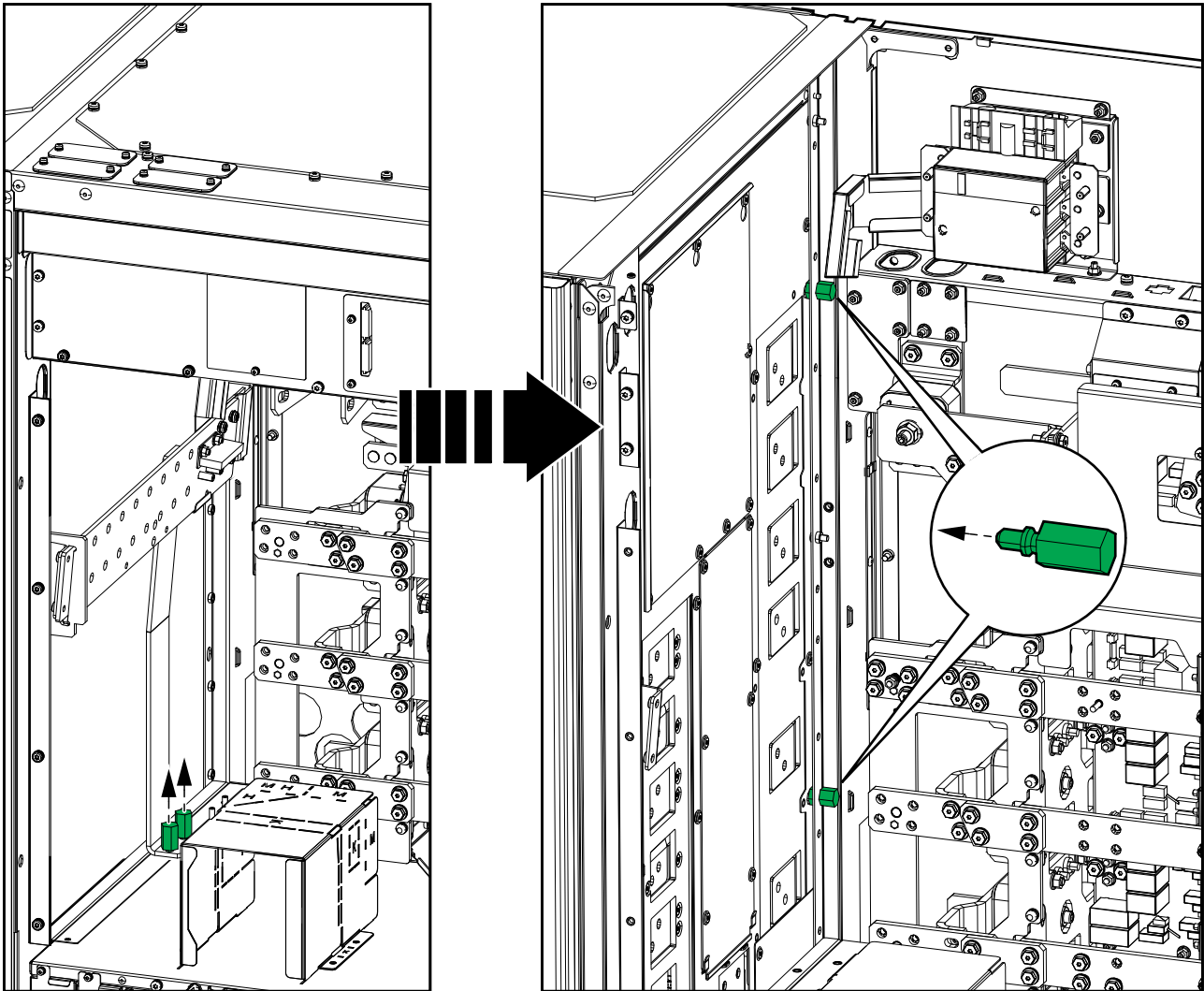

Prepare the UPS for Internal Busbar Connection

1. **Only for HRG earthing system:** Remove and discard the two preconnected cables that connect the E terminal on the bonding contactor to the ground busbar.

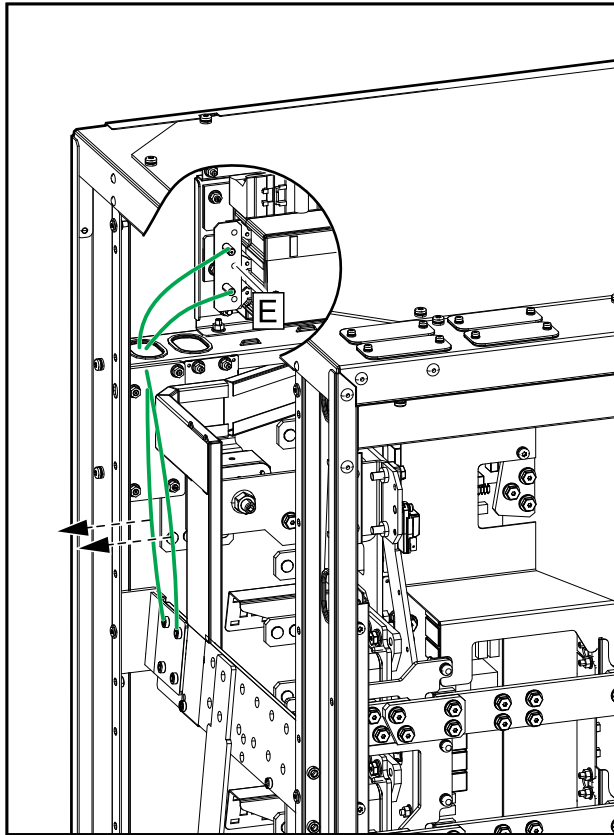

2. Reposition the ground busbar in the UPS:
 - a. Disconnect the EMC cable, the EMC cable holder and the bonding cables from the ground busbar. Note the connection of the cables on the ground busbar.
 - b. Remove and discard the copper busbar.
 - c. Move the ground busbar to the new position.
 - d. Hold onto the EMC cable holder and pull gently on the end of the EMC cable to extend the length. Reconnect the EMC cable to the ground busbar.
 - e. Reconnect the bonding cables to the ground busbar

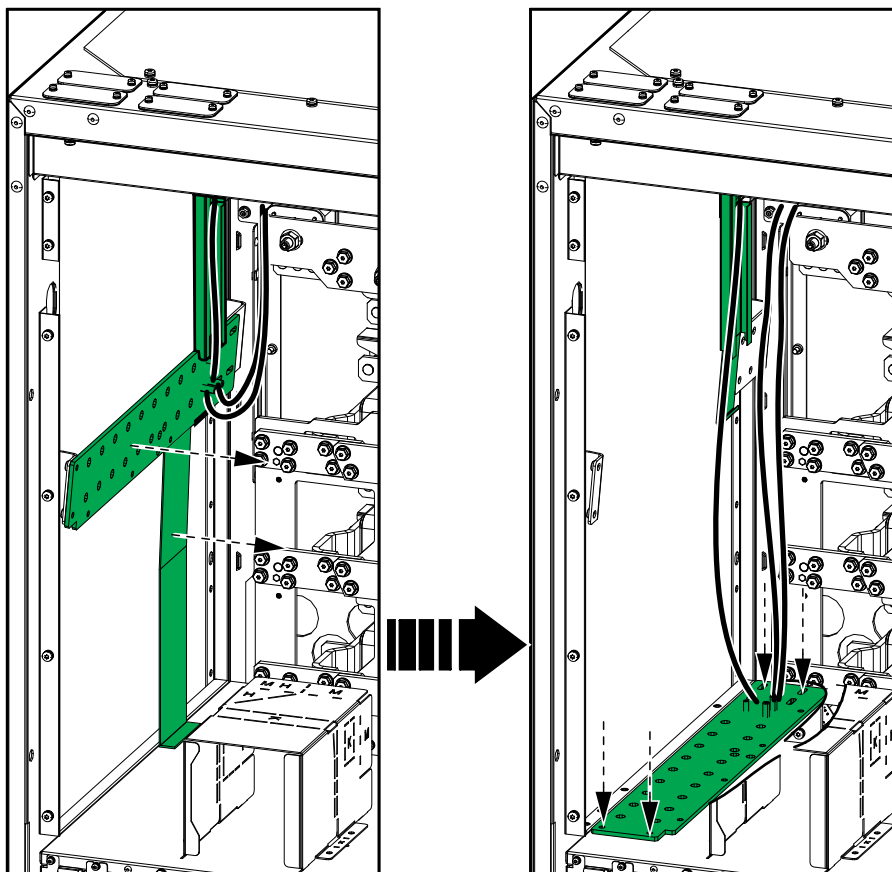

3. **Only for HRG earthing system:** Connect an external impedance between the E terminal on the bonding contactor and the ground busbar according to NEC 2014 article 250.36.

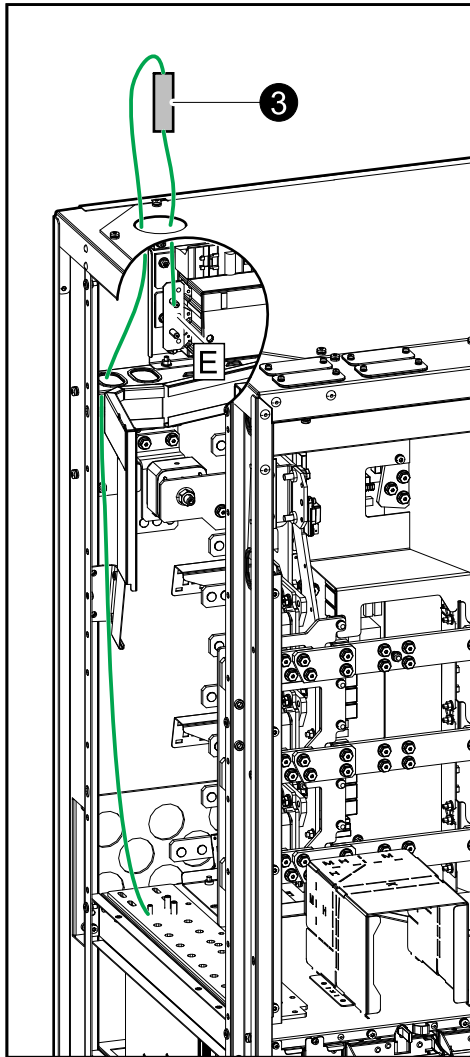

4. **Only for UPS with the plastic box as a separate part:** Bend the M zone flaps upwards on the plastic box. This is necessary to make room for the internal busbars between the maintenance bypass cabinet and the UPS. Skip this step if the box is integrated in the inner door of the UPS. The integrated box does not need modification to fit with the internal busbars.

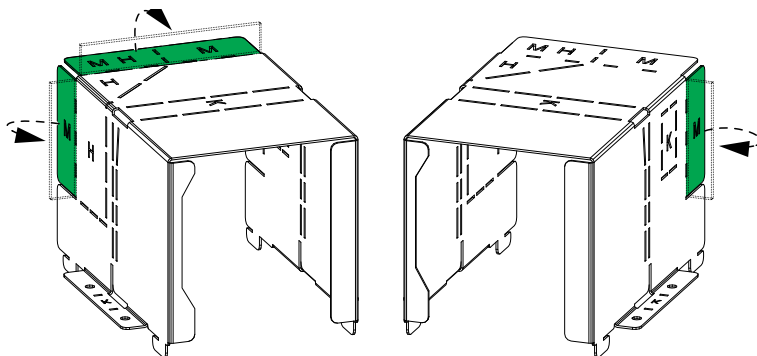

Install Busbars Between the UPS and the Maintenance Bypass Cabinet in Single Mains System

The busbars and insulator parts are provided in a kit with the maintenance bypass cabinet. The part numbers shown on the illustrations are printed on the parts. Use the provided M8x30 screws and torque to 17.5 Nm (12.91 lb-ft / 154.9 lb-in).

1. Install the neutral busbars, the DC busbars, the insulator part, and the ground busbar.

Front View of the UPS

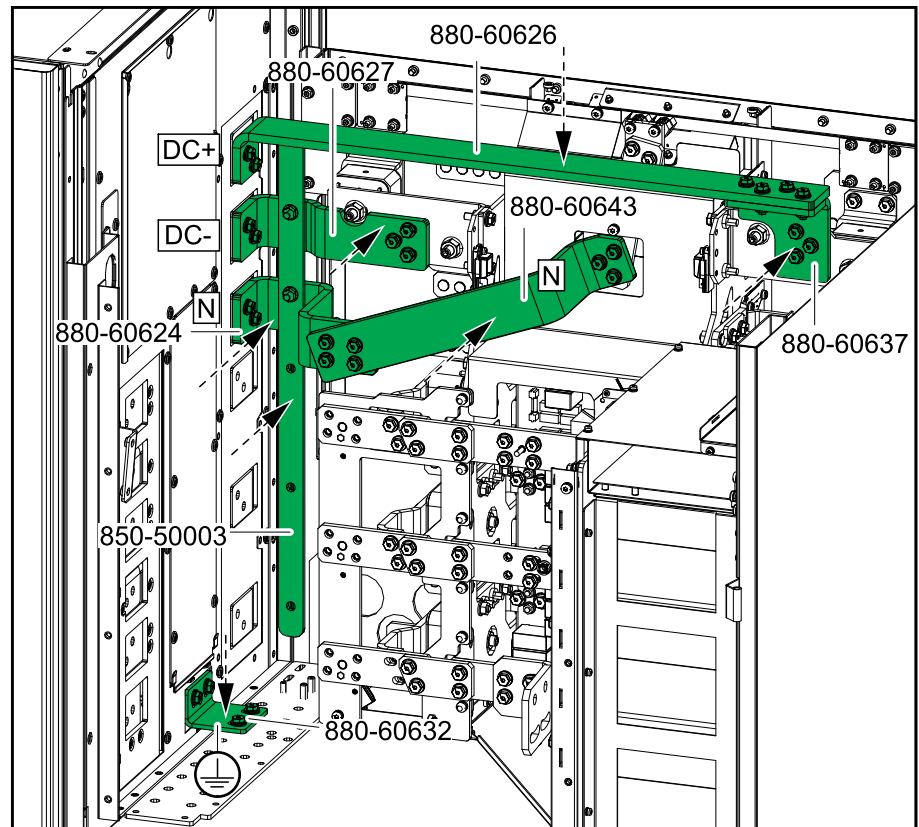

2. Install the input busbars and the insulator part.

Front View of the UPS

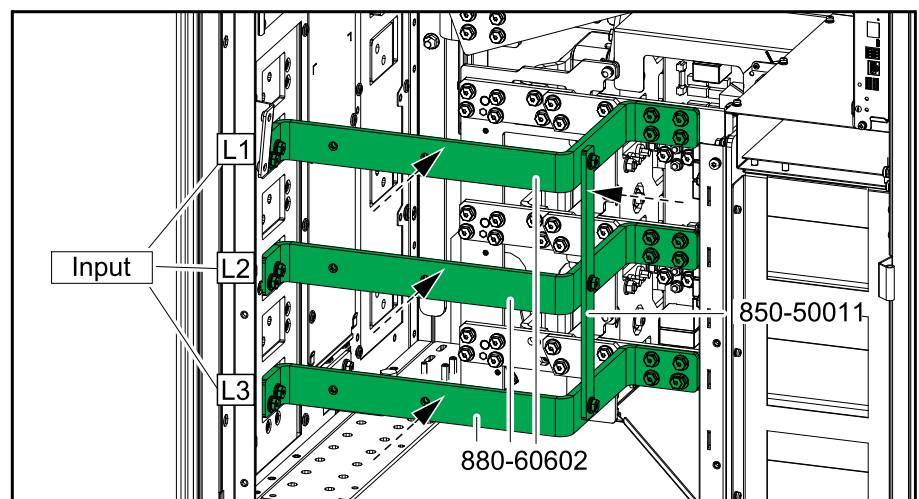

3. Install the output busbars and the insulator parts.

Front View of the UPS

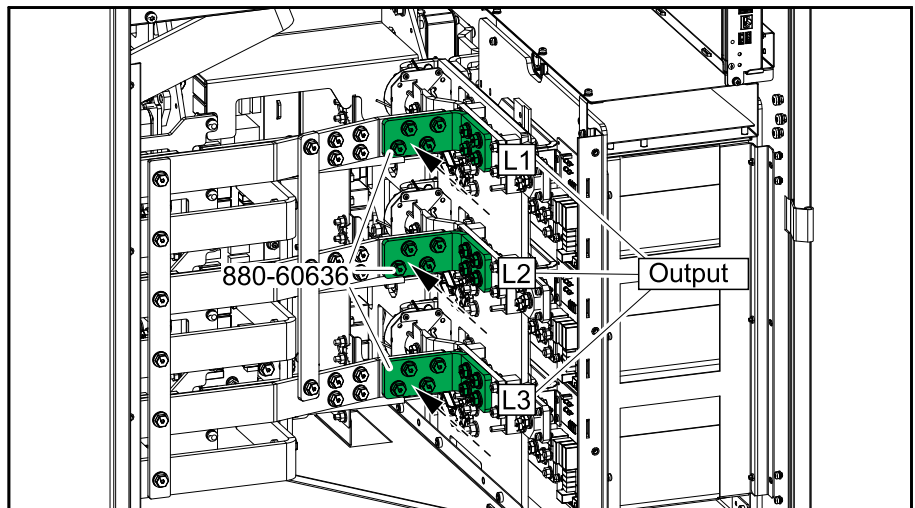
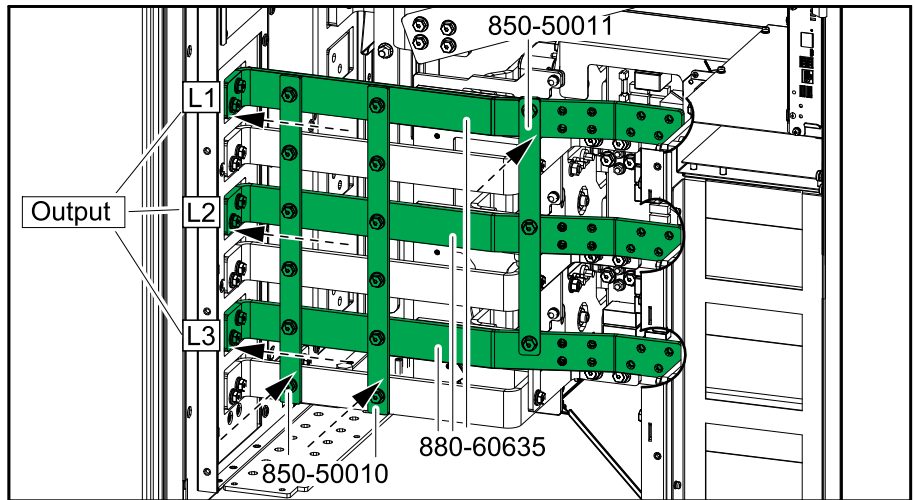

Install Busbars Between the UPS and the Maintenance Bypass Cabinet in Dual Mains System

The busbars and insulator parts are provided in a kit with the maintenance bypass cabinet. The part numbers shown on the illustrations are printed on the parts. Use the provided M8x30 screws and torque to 17.5 Nm (12.91 lb-ft / 154.9 lb-in).

1. Remove the three single mains busbars.

NOTE: Save the three single mains busbars. They are needed for testing during start-up of the UPS.

Front View of the UPS

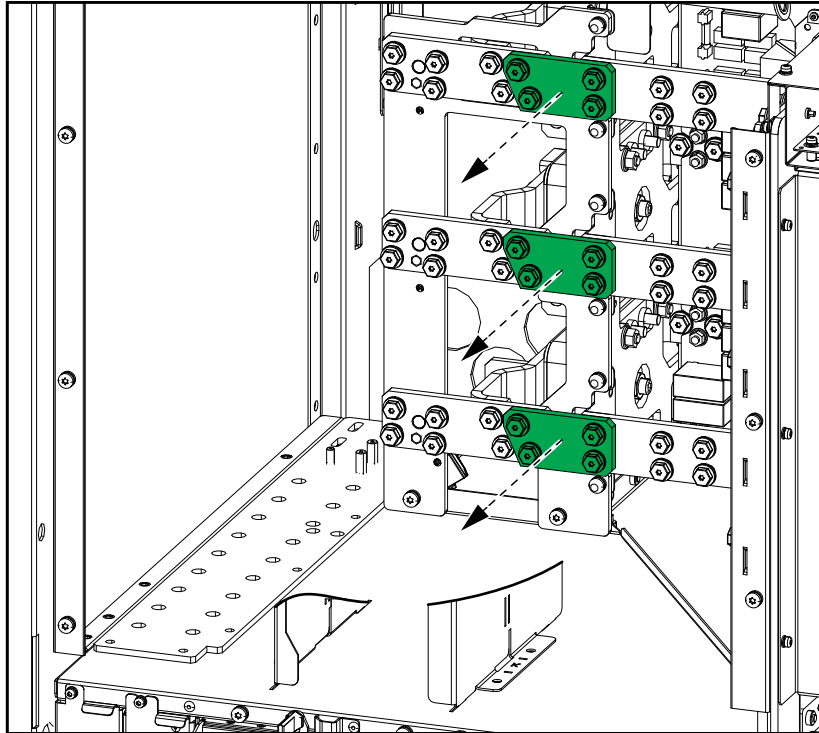

2. Install the input busbars, the neutral busbar, the DC busbars, the insulator part, and the ground busbar.

Front View of the UPS

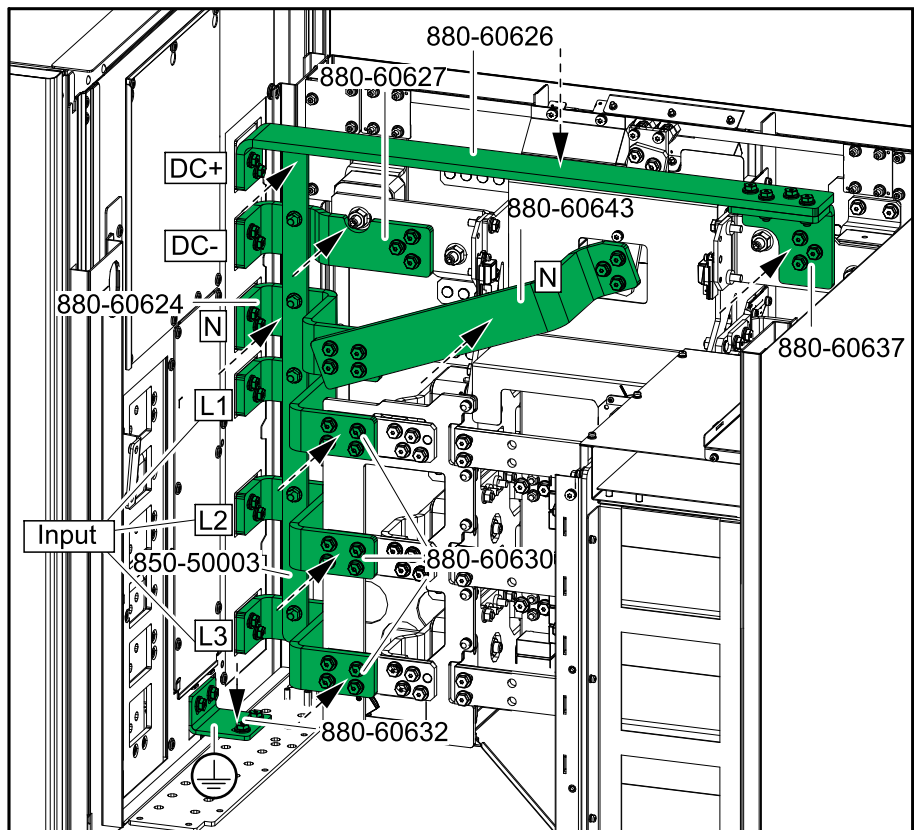

3. Install the bypass busbars and the insulator part.

Front View of the UPS

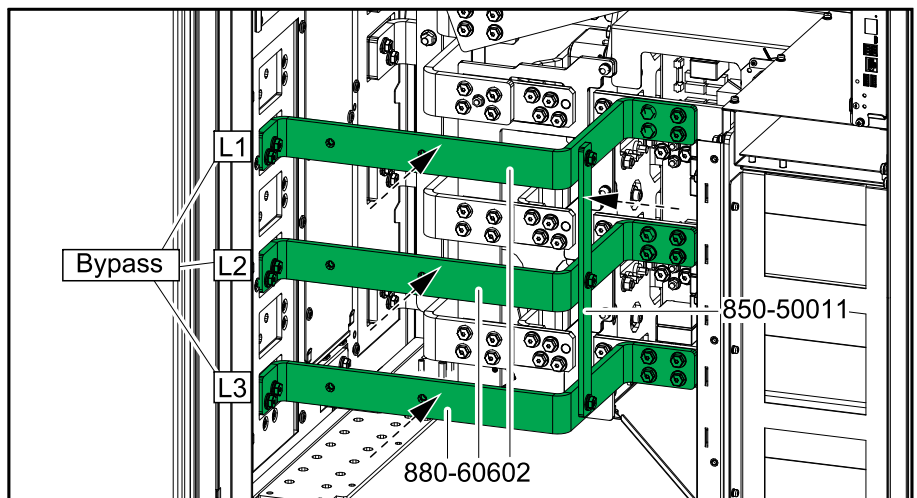

4. Install the output busbars and the insulator parts.

Front View of the UPS

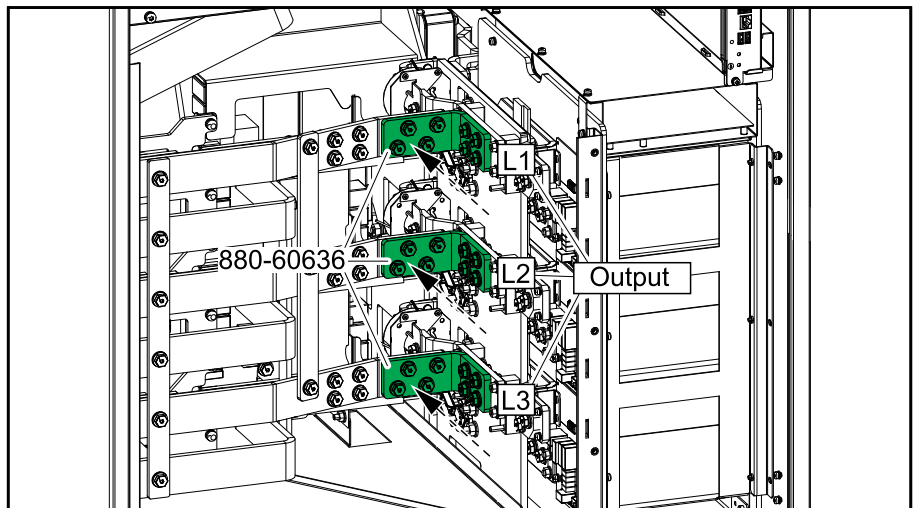
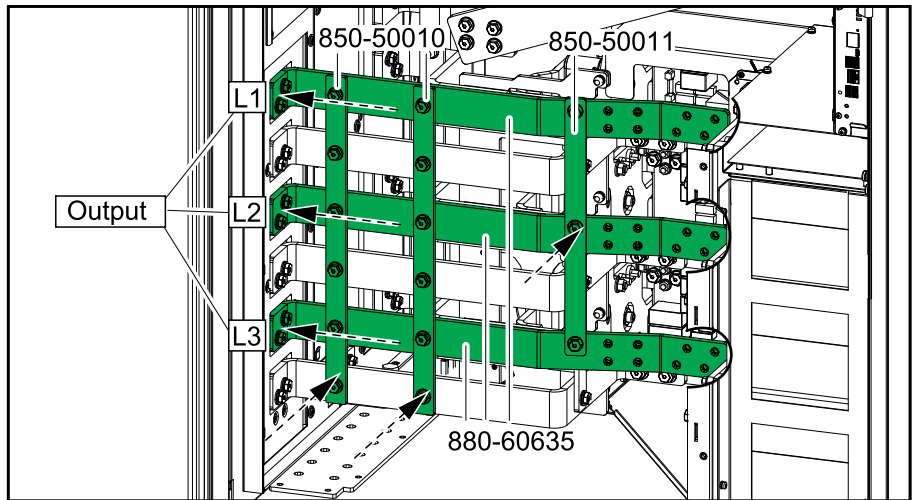

Install Busbars for Load Bank Breaker (Option)

NOTE: The busbars for the load bank breaker were removed from the UPS during preparation for installation.

1. Install busbars for load bank breaker (LBB) in the UPS. Note the direction of the busbars.

Front View of the UPS

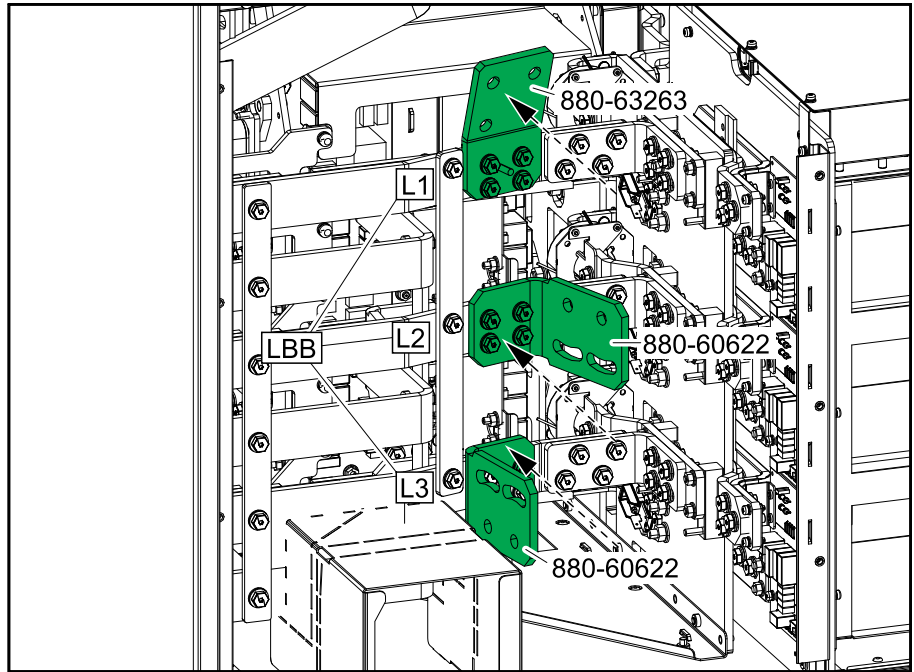

2. The load bank breaker cables can be routed through the top of the UPS for a permanent installation or through the open inner door for a temporary installation. See the UPS manual for information on how to create top cable entry in the UPS.

Prepare for Signal Cables in Top Cable Entry Systems

⚠ DANGER

HAZARD OF ELECTRIC SHOCK, EXPLOSION, OR ARC FLASH

Do not drill or punch holes with the gland plates installed and do not drill or punch holes in close proximity to the cabinet.

Failure to follow these instructions will result in death or serious injury.

1. Prepare the UPS for signal cables:
 - a. Remove the cover.
 - b. Remove the gland plates and brush plates from the top of the UPS.

Front View of the UPS

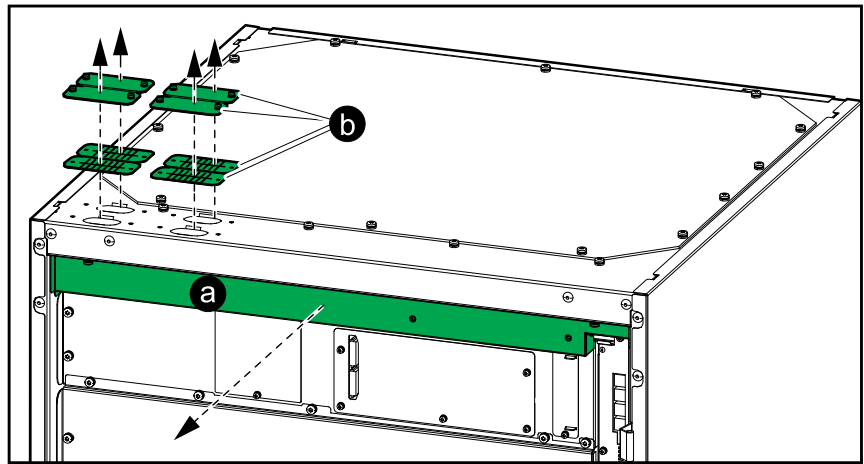

- c. **For installation without conduits:** Reinstall the brush plates.
 - d. **For installation with conduits:** Drill a hole in the gland plates for conduits, install conduits, and reinstall the gland plates.
2. Route the signal cables as shown to separate the Class 2/SELV cables from the non-Class 2/non-SELV cables. A divider inside the cable channel separates the cables.

Front View of the UPS

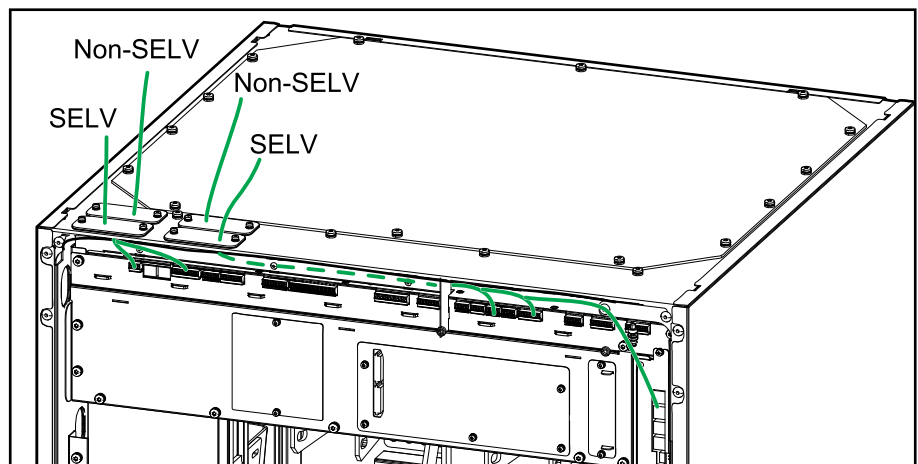

Prepare for Signal Cables in Bottom Cable Entry Systems

⚠ DANGER

HAZARD OF ELECTRIC SHOCK, EXPLOSION, OR ARC FLASH

Do not drill or punch holes with the gland plates installed and do not drill or punch holes in close proximity to the cabinet.

Failure to follow these instructions will result in death or serious injury.

1. Remove the covers.

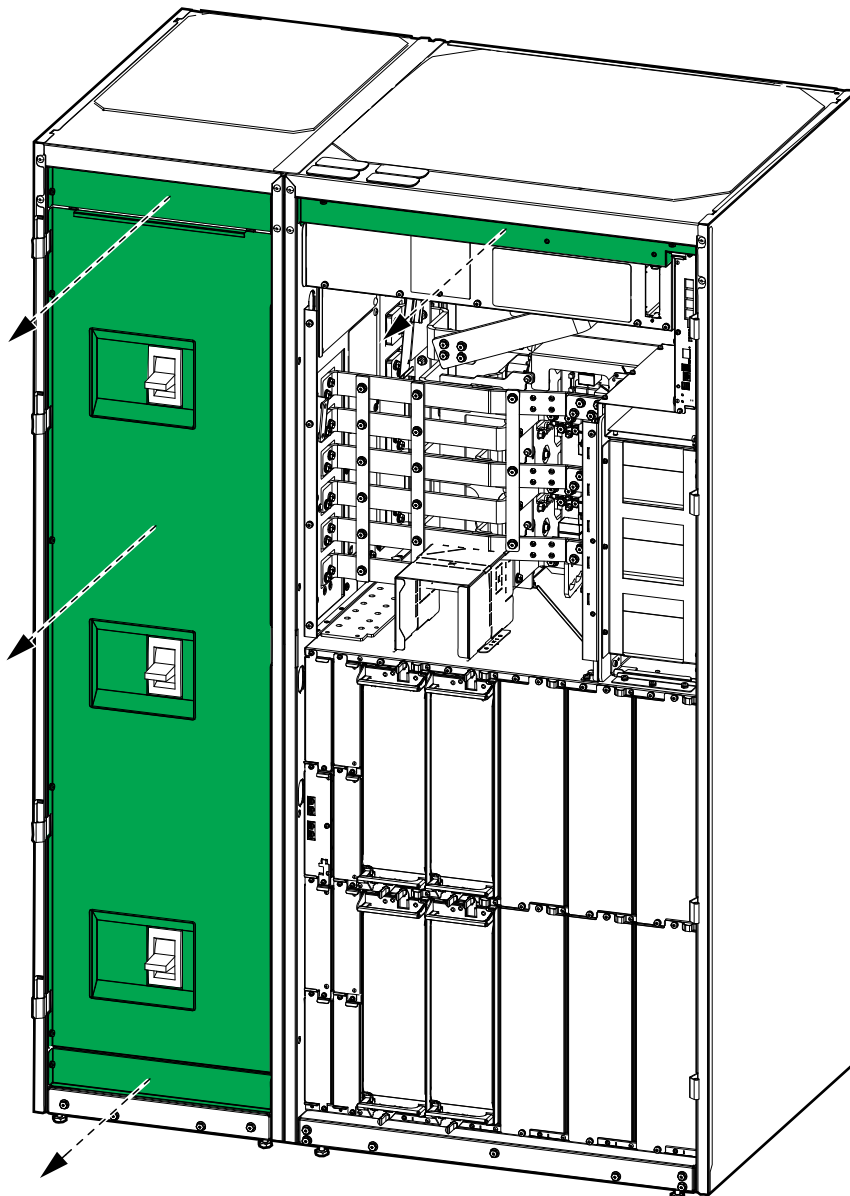

2. Prepare for signal cables:
 - a. Remove the gland plates.
 - b. Drill/punch holes for signal cables or conduits in the gland plate. Install conduits (not provided), if applicable.
 - c. Reinstall the gland plates.

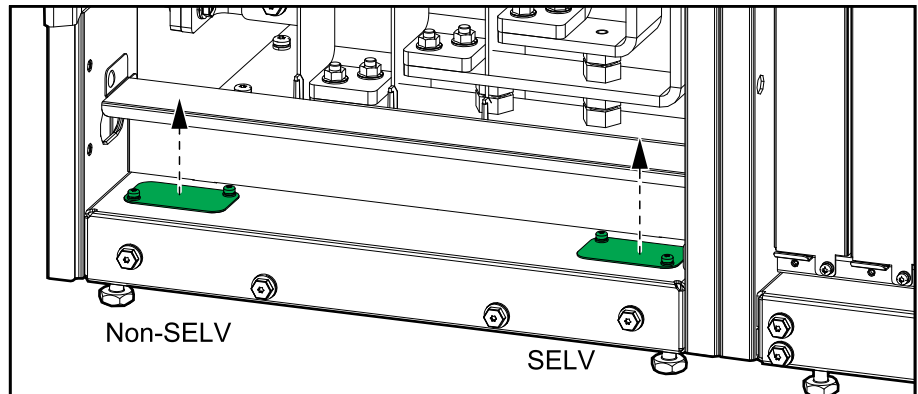

3. Route the signal cables from the UPS, into the maintenance bypass cabinet, and out through the bottom of the maintenance bypass cabinet.

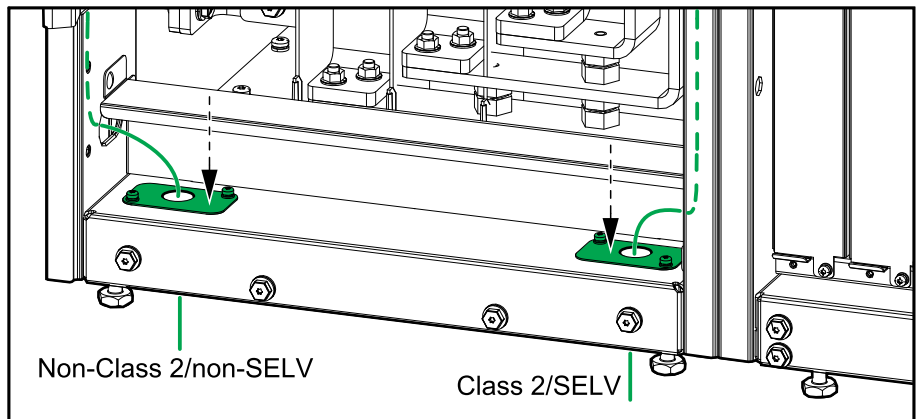
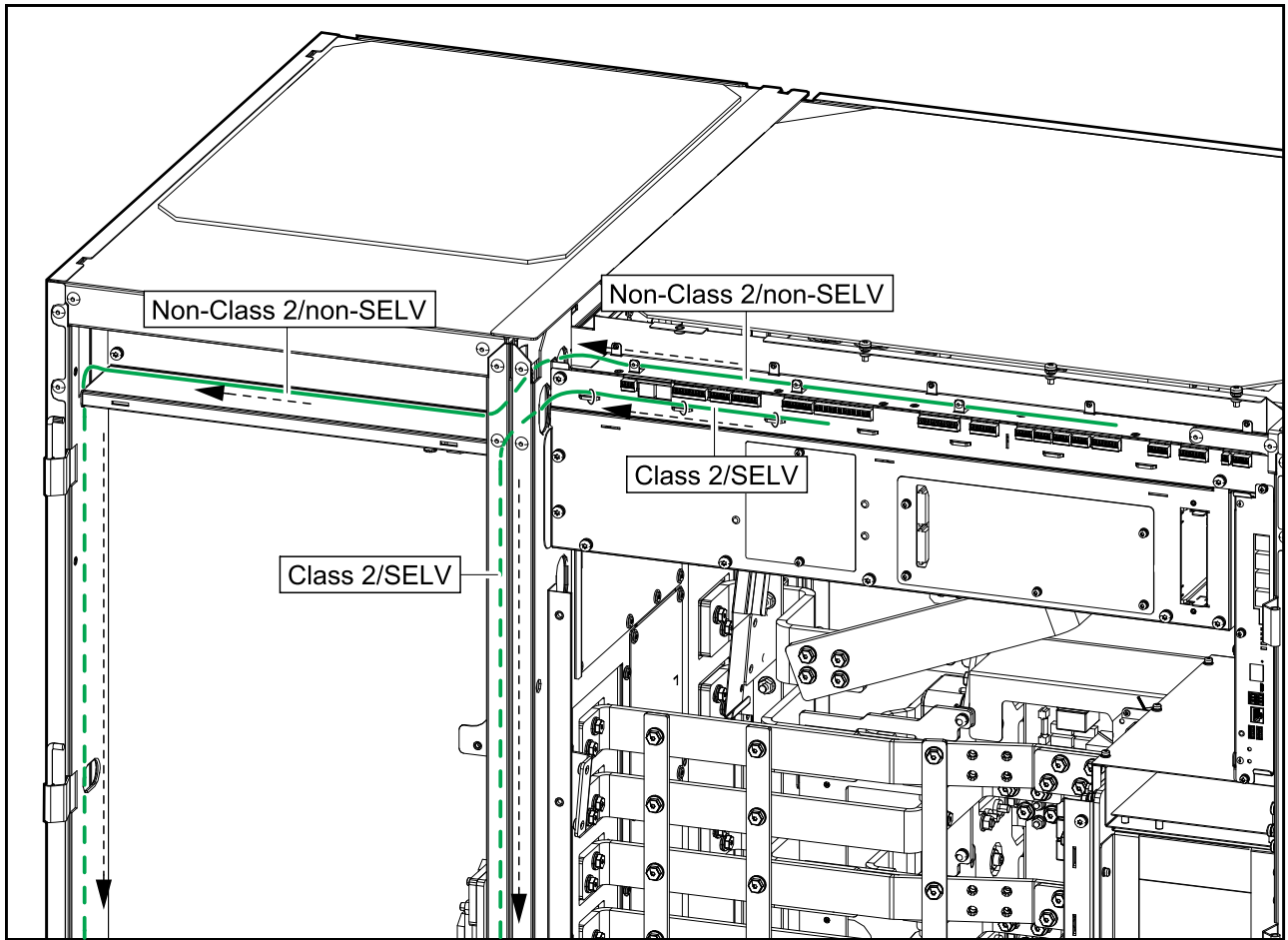

4. Reinstall the covers.

Connect the Signal Cables Between the Maintenance Bypass Cabinet and the UPS

1. Connect the provided Class 2/SELV signal cable 0W50021 and the provided non-Class 2/non-SELV signal cable 0W50023 between the maintenance bypass cabinet and the UPS as shown.

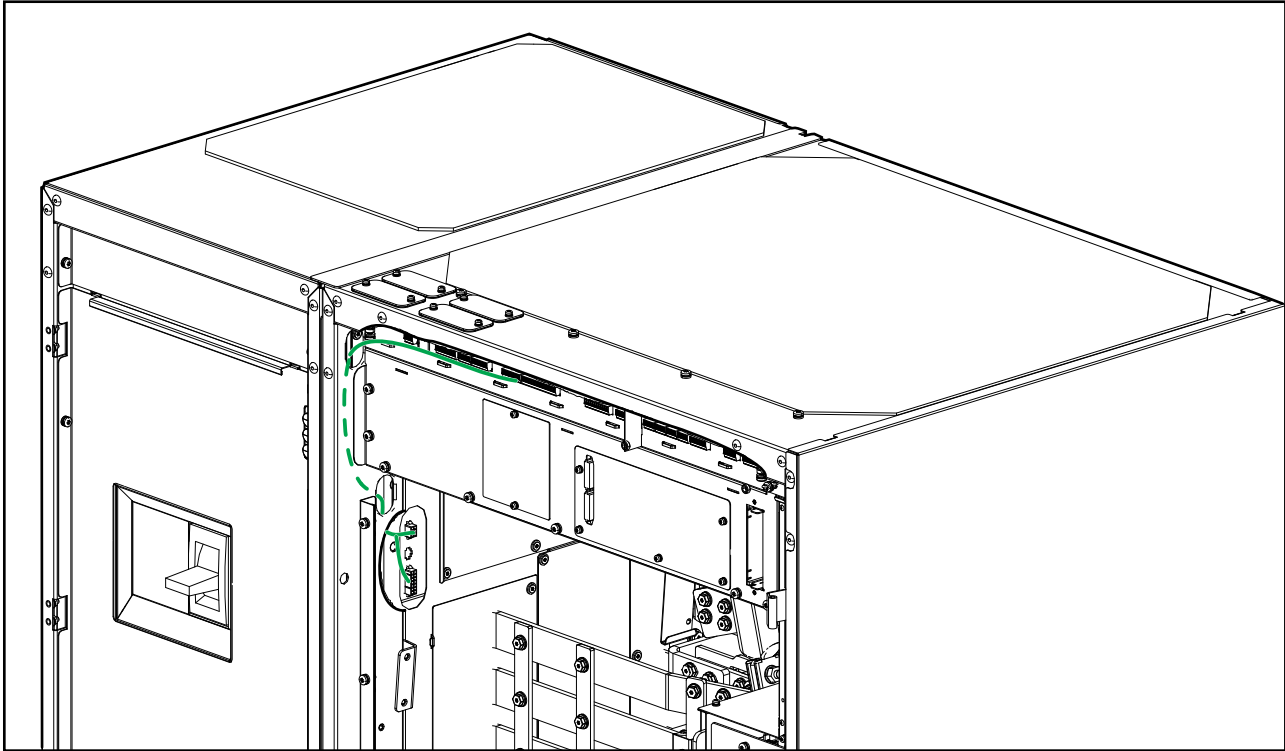

Single Mains System

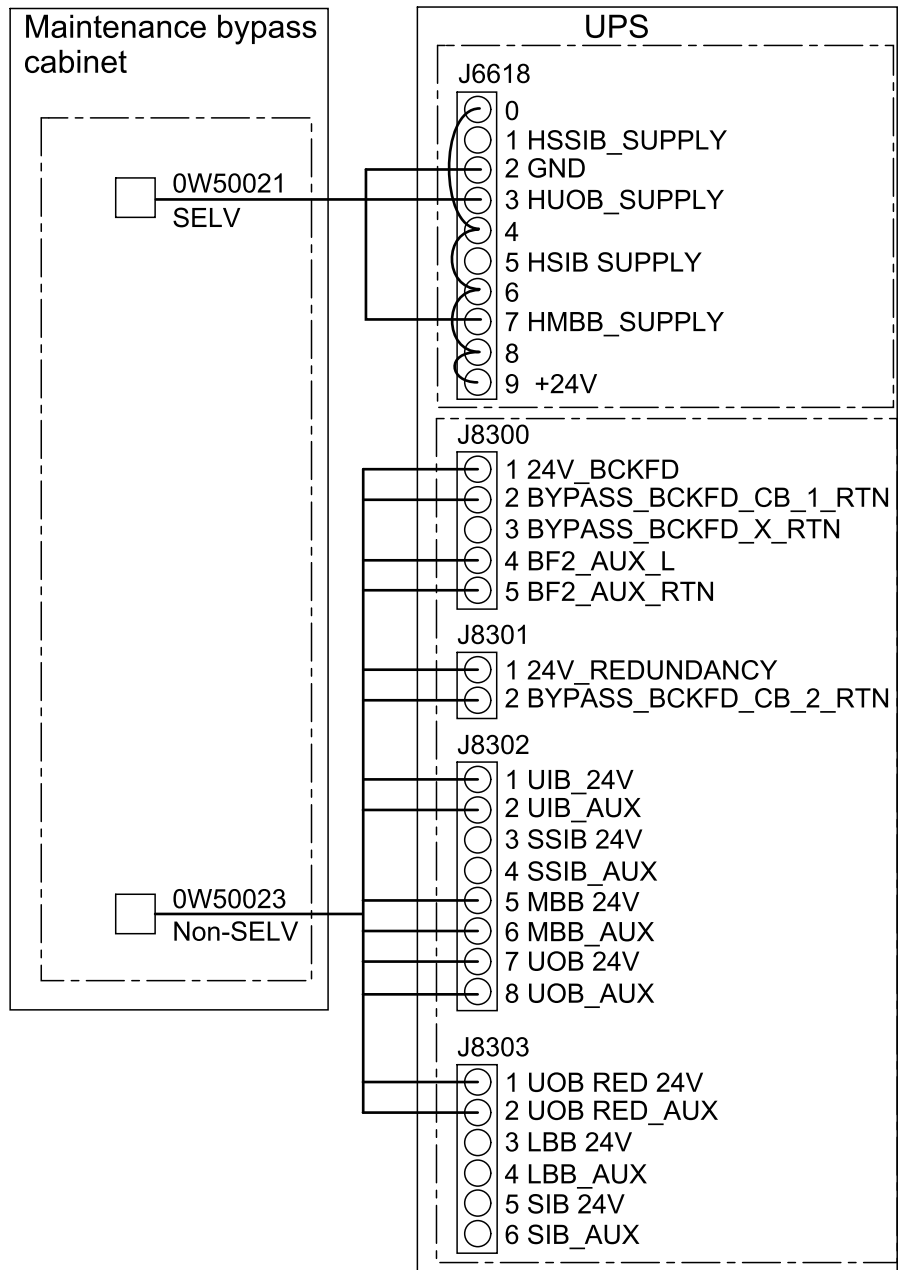

Dual Mains System

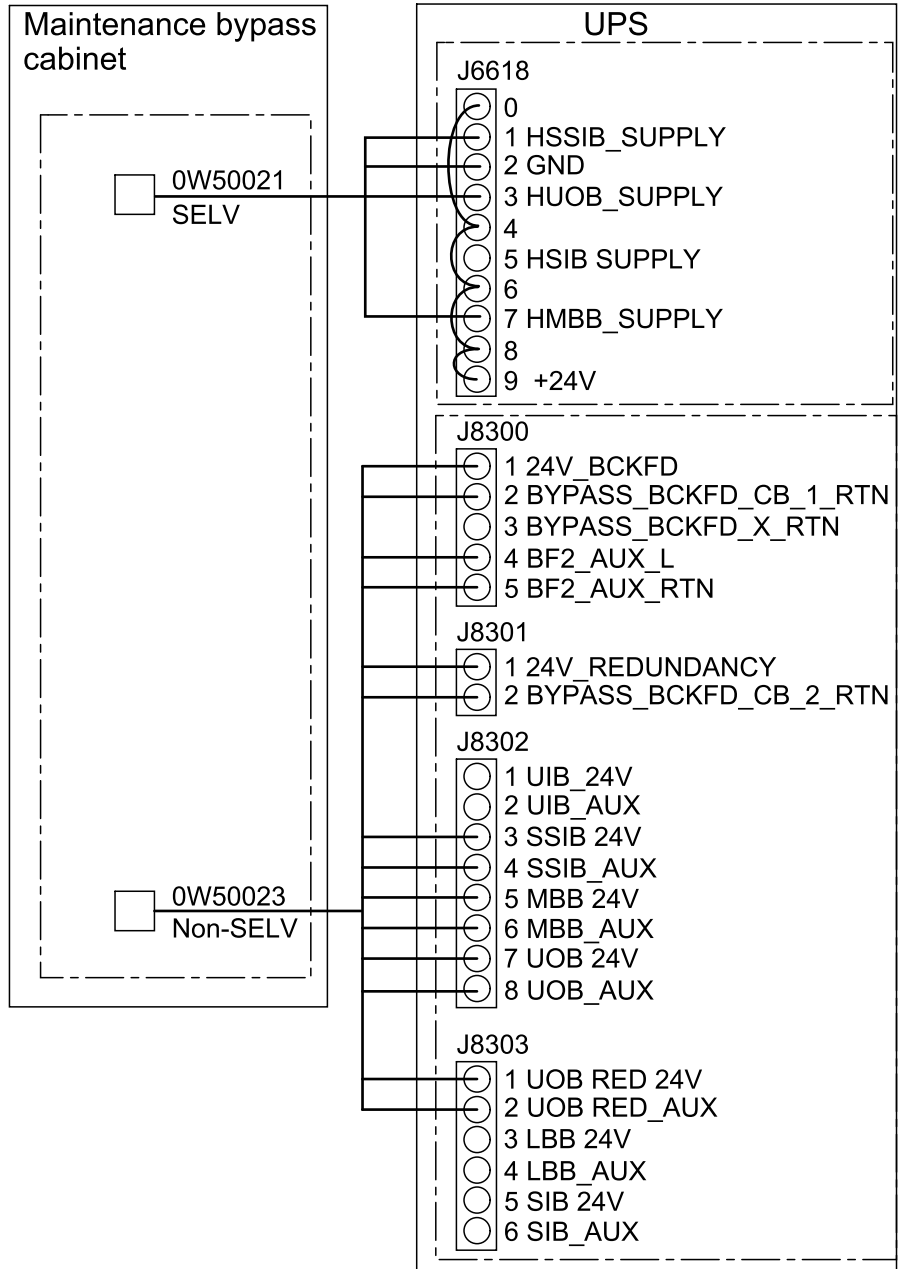

Add Translated Safety Labels to Your Product

The safety labels on your product are in English and French. Sheets with translated safety labels are provided with your product.

1. Find the sheets with translated safety labels provided with your product.
2. Check which 885-xxx/TMExxxx numbers are on the sheet with translated safety labels.
3. Locate the safety labels on your product that match the translated safety labels on the sheet – look for the 885-xxx/TMExxxx numbers.
4. Add the replacement safety label in your preferred language to your product on top of the existing French safety label.

Final Installation

1. **Only for dual mains:** Add the labels for SSIB, the indicator lights, and the diagram label on the maintenance bypass cabinet. The labels are provided with this manual.

Single Mains

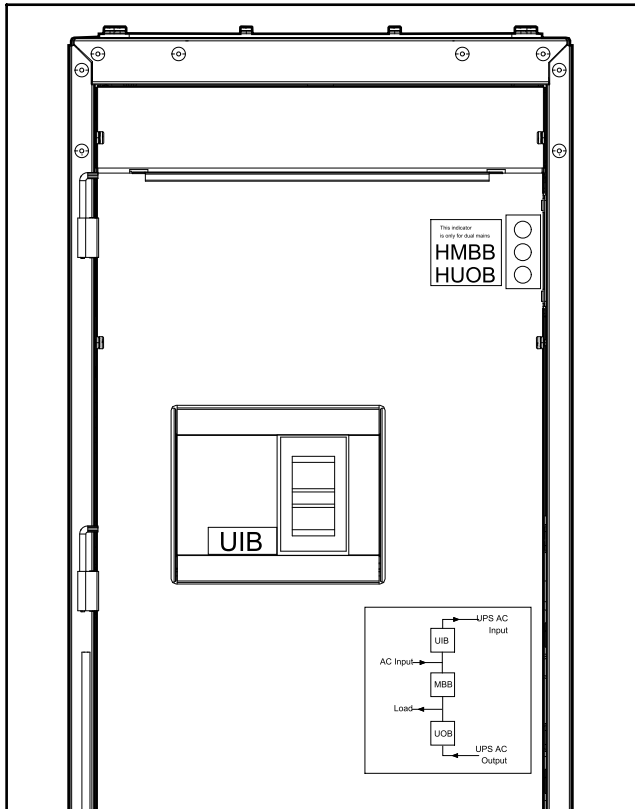

Dual Mains

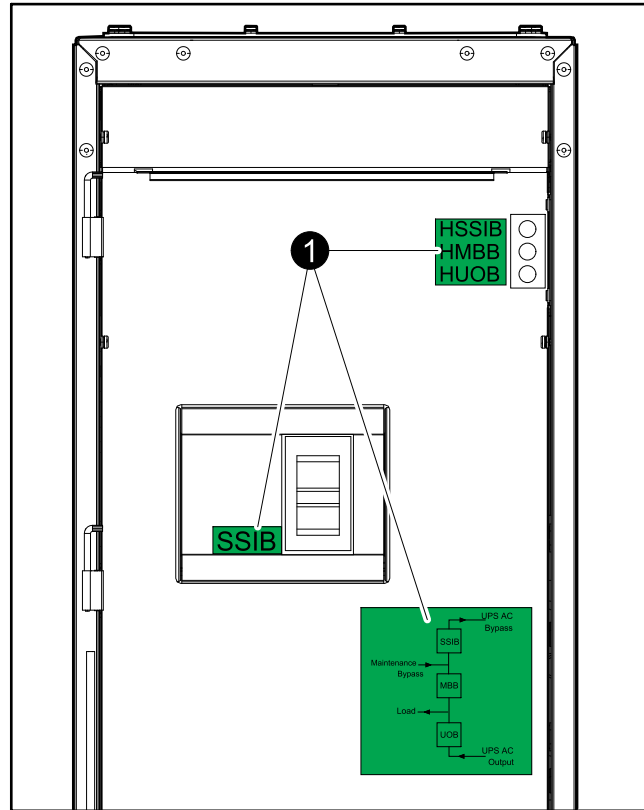

2. Add label 885-91965 (provided with the UPS) on the maintenance bypass cabinet.
3. **Only for seismic anchoring:** Install the seismic front anchoring bracket on the maintenance bypass cabinet and on the UPS. Mount the seismic front brackets to the floor. Use appropriate hardware for the floor type – the hole diameter in the seismic front bracket is $\varnothing 14$ mm. The minimum requirement is M12 strength grade 8.8 hardware.

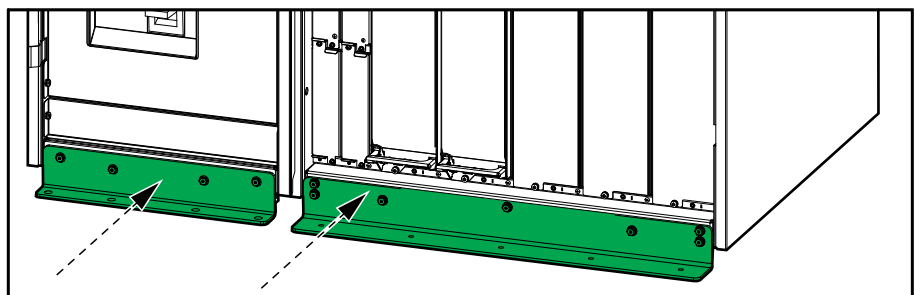

4. Close the front door on the maintenance bypass cabinet

Decommission or Move the Maintenance Bypass Cabinet to a New Location

NOTE: Follow the instructions in the UPS installation manual to prepare the UPS for being moved/decommissioned.

1. Shut down the UPS system completely.
2. Lockout/Tagout all breakers in the maintenance bypass cabinet in the OFF (open) position.
3. Lockout/Tagout all breakers in the upstream switchgear in the OFF (open) position.
4. Lockout/Tagout all battery breakers in the switchgear/battery solution in the OFF (open) position.
5. Open the front door of the maintenance bypass cabinet and the UPS.
6. If present, Lockout/Tagout the backfeed breaker BF2 in the OFF (open) position on the UPS.
7. Remove the two plates from the maintenance bypass cabinet.

Front View of the Maintenance Bypass Cabinet

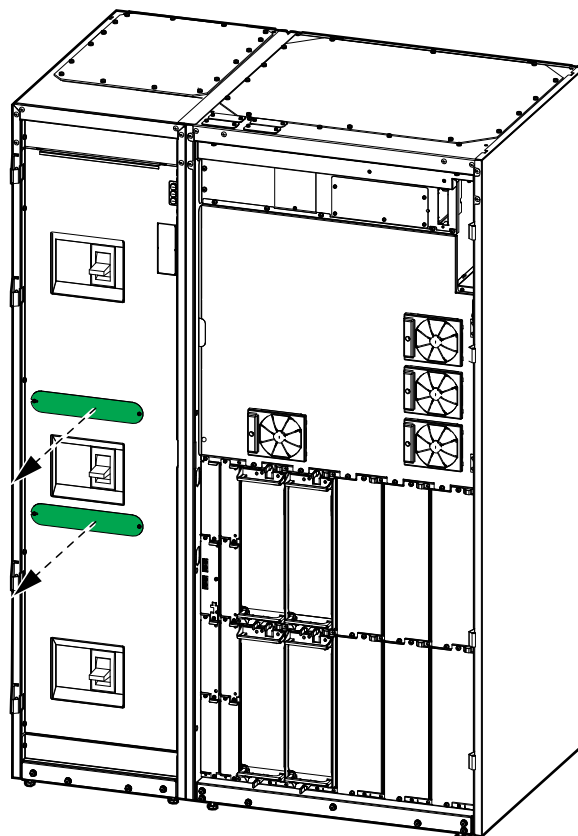

⚡ ⚠ DANGER

HAZARD OF ELECTRIC SHOCK, EXPLOSION, OR ARC FLASH

- Do not remove any other plates or panels while there is power on the system.
- Before any work activity is started it, must be confirmed with measurements directly on the terminals that no power is present.

Failure to follow these instructions will result in death or serious injury.

8. On the maintenance bypass cabinet, measure for and verify ABSENCE of voltage with a multimeter probe through the holes in the transparent plate for input, bypass, output, neutral, and DC.

⚡⚠ DANGER

HAZARD OF ELECTRIC SHOCK, EXPLOSION, OR ARC FLASH

Measure for and verify ABSENCE of voltage with a multimeter probe through the holes in the transparent plate for input, bypass, output, and DC.

Failure to follow these instructions will result in death or serious injury.

NOTE: The circuit breakers in GVLMBCA250K500G are 3-poled and do not have a neutral connection.

Front View of the Maintenance Bypass Cabinet – Single Mains System

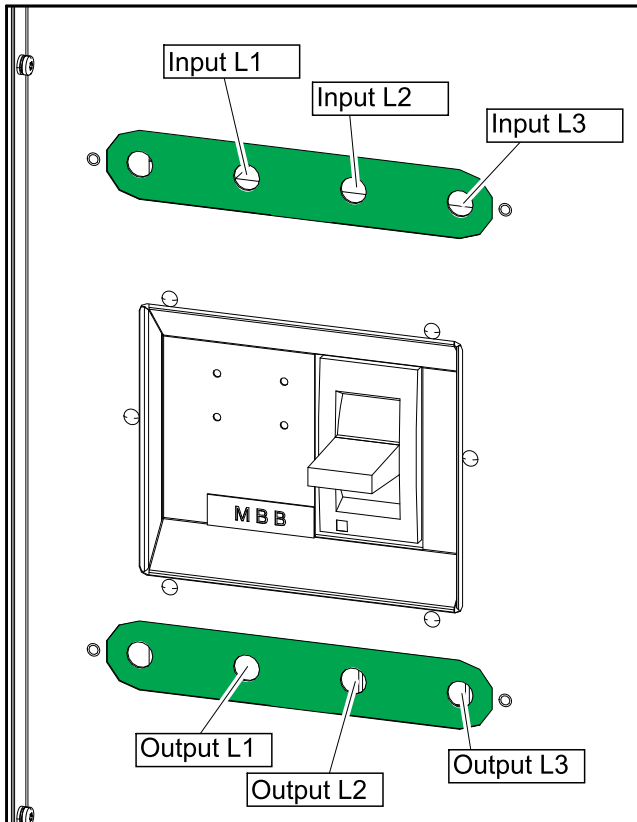

Front View of the Maintenance Bypass Cabinet – Dual Mains System

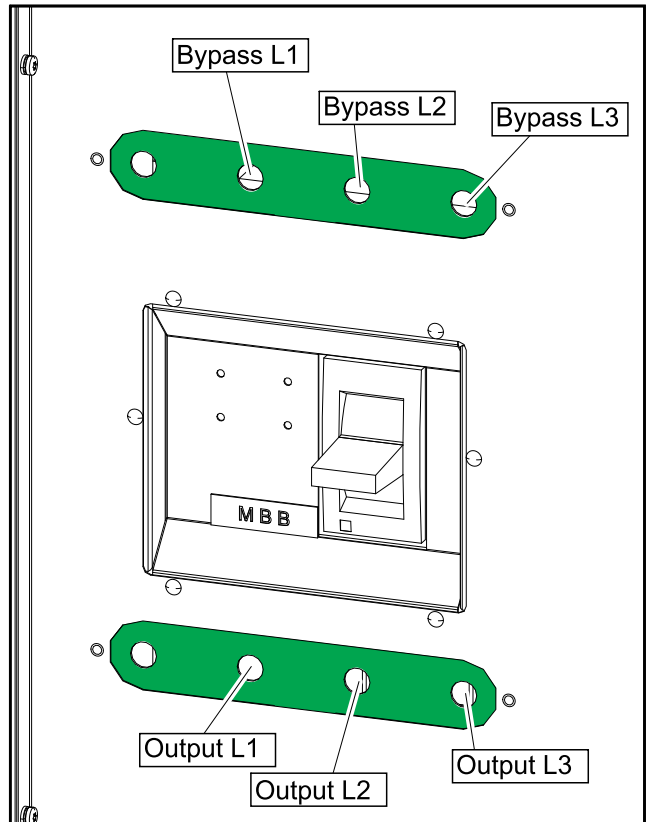

9. On the UPS, measure for and verify ABSENCE of voltage with a multimeter probe through the holes in the transparent plate for input, bypass, output, neutral, and DC.

Front View of the UPS

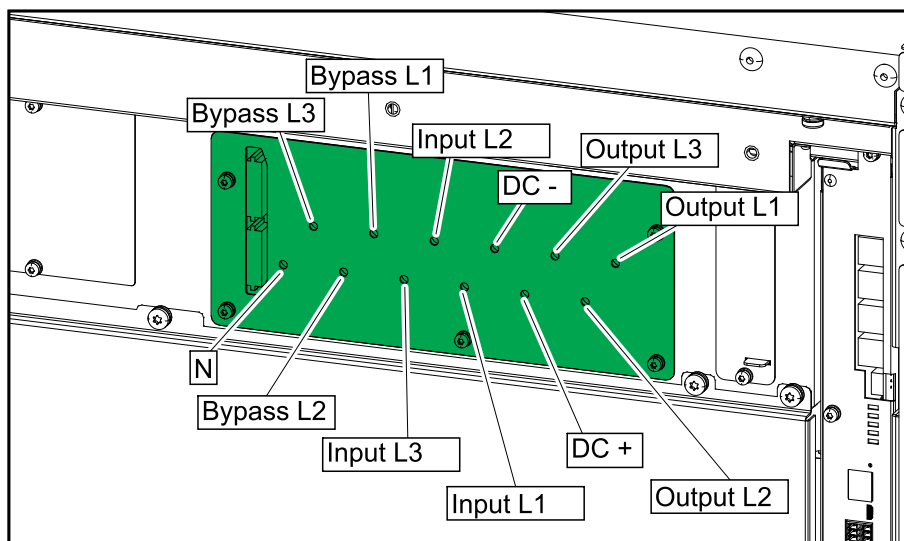

10. Open the inner door of the UPS.
11. On the UPS, measure for and verify ABSENCE of voltage on each input/ bypass/output/DC busbar before continuing.

DANGER

HAZARD OF ELECTRIC SHOCK, EXPLOSION, OR ARC FLASH

Measure for and verify ABSENCE of voltage on each input/bypass/output/ DC busbar before continuing.

Failure to follow these instructions will result in death or serious injury.

12. Remove the busbars and insulator parts that connect the UPS to the maintenance bypass cabinet. See *Install Busbars Between the UPS and the Maintenance Bypass Cabinet in Single Mains System*, page 38 or *Install Busbars Between the UPS and the Maintenance Bypass Cabinet in Dual Mains System*, page 40 for details. Save all parts for reinstallation.
13. Remove the top bracket and the screws in the front that interconnect the UPS and the maintenance bypass cabinet externally. Remove the two special screws that interconnect the UPS and the maintenance bypass cabinet internally. See *Interconnect the UPS with the Maintenance Bypass Cabinet*, page 32 for details. Save all parts for reinstallation.

14. **If external sync is present:** Remove the transparent protection cover from the external synchronization board 0P4809. The external synchronization board 0P4809 is located on the rear of the front plate. Disconnect the signal cables from the external synchronization board 0P4809.

⚡ ⚠ DANGER

HAZARD OF ELECTRIC SHOCK, EXPLOSION, OR ARC FLASH

Check for absence of voltage for all three signal terminals on the external synchronization board 0P4809. When the external synchronization cables are installed, the terminals on the external synchronization board 0P4809 may be energized. Disconnect the fuse disconnecter device at the source before removing the transparent protection cover.

Failure to follow these instructions will result in death or serious injury.

Front View of the UPS

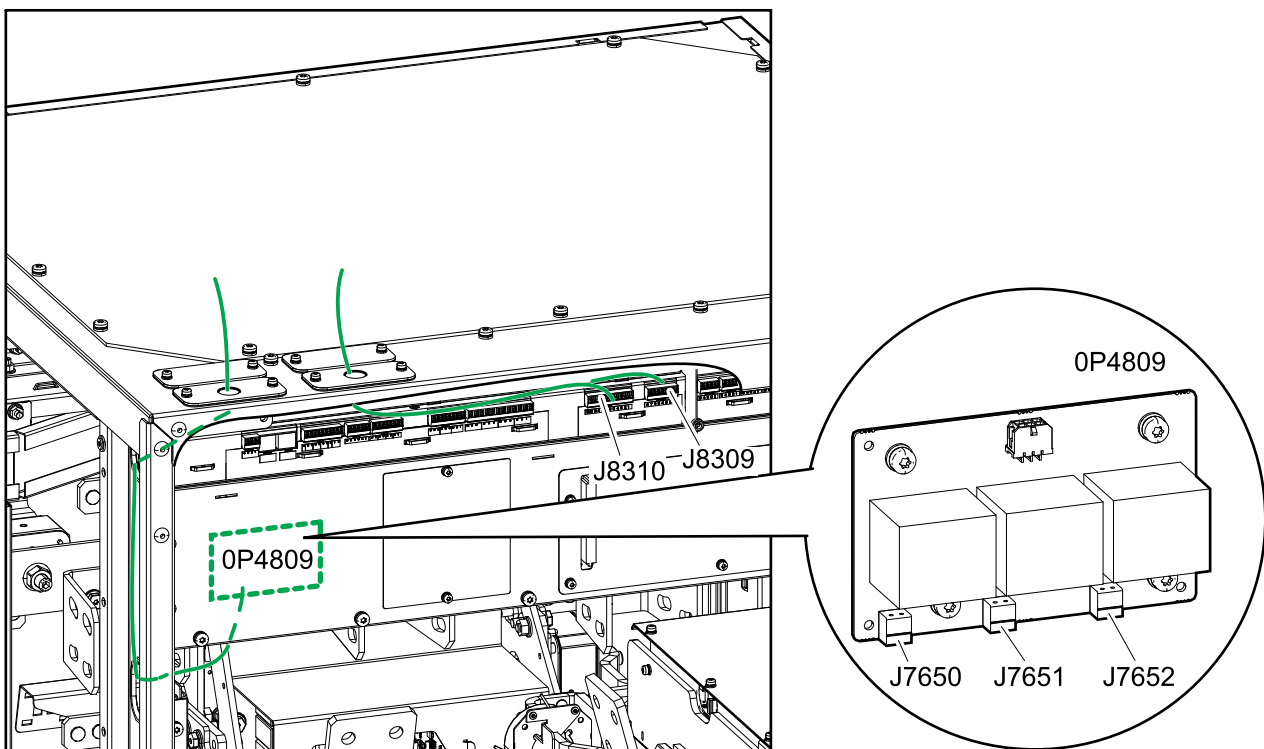

15. Close the inner door of the UPS and reinstall the screws.
16. Disconnect and remove any signal cables from the UPS.
17. Remove the seismic front anchoring bracket/front transportation bracket from the UPS and the maintenance bypass cabinet. Save for reinstallation.
18. Close and lock the front door of the UPS.
19. Raise the feet of the UPS until the casters have full contact with the floor.

20. Move the UPS out of the way of the maintenance bypass cabinet by rolling it on the casters.

⚠ WARNING

TIPPING HAZARD

- The casters of the UPS are exclusively for transport on flat, even, hard, and horizontal surfaces.
- The casters of the UPS are intended for transport over short distances (i.e. inside the same building).
- Move at a slow pace and pay close attention on the floor conditions and the balance of the UPS.

Failure to follow these instructions can result in death, serious injury, or equipment damage.

21. Remove the right side panel from the maintenance bypass cabinet.

The Maintenance Bypass Cabinet

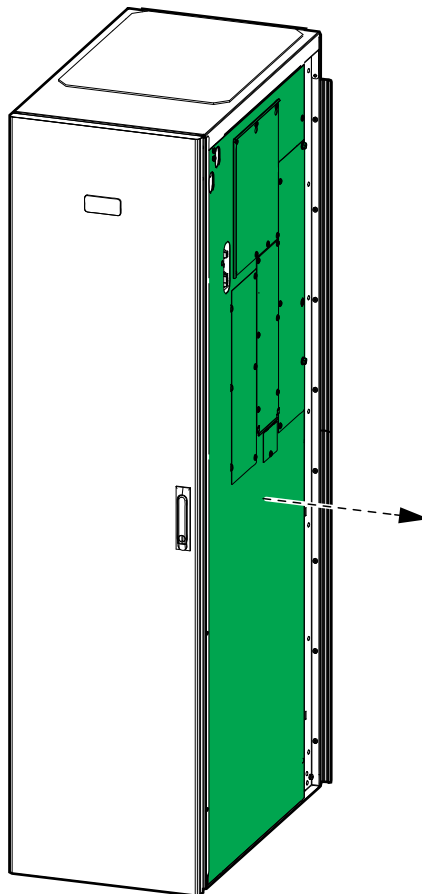

22. Measure for and verify ABSENCE of voltage on each input/bypass/output/DC busbar in the maintenance bypass cabinet before continuing.

⚡ DANGER

HAZARD OF ELECTRIC SHOCK, EXPLOSION, OR ARC FLASH

Measure for and verify ABSENCE of voltage on each input/bypass/output/DC busbar before continuing.

Failure to follow these instructions will result in death or serious injury.

Single Mains

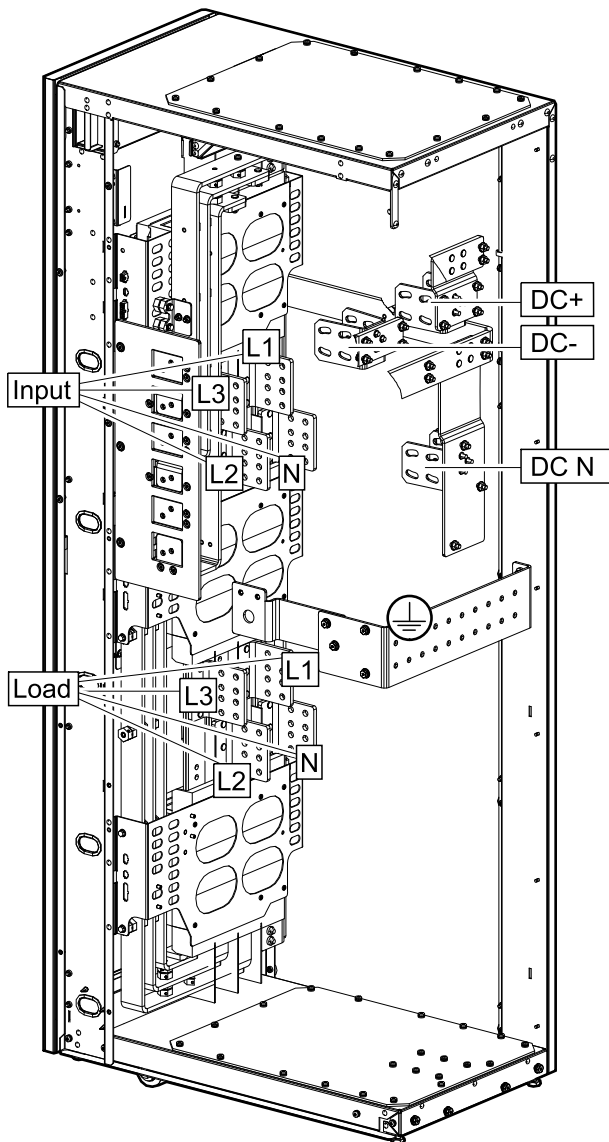

Dual Mains

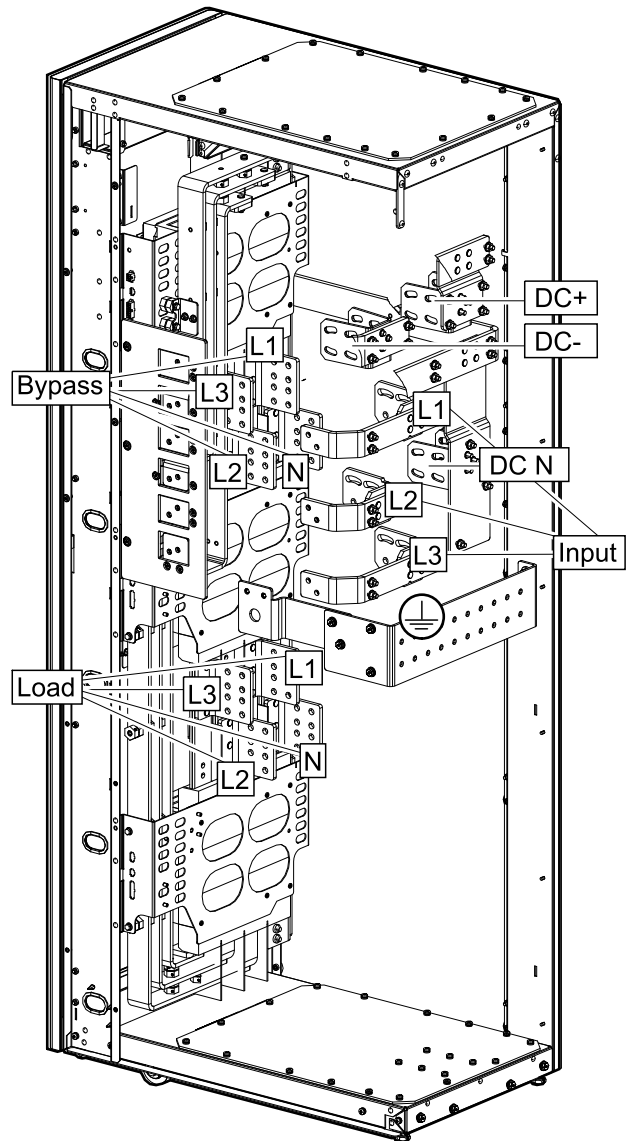

23. Remove the power cables from the maintenance bypass cabinet. See [Connect the Power Cables](#), page 26 for details.

24. Perform the following on the maintenance bypass cabinet to reposition parts to their original position. See *Prepare for Installation*, page 20 for details.
 - a. Remove the left side panel from the maintenance bypass cabinet and reinstall it on the left side of the UPS.
 - b. Reinstall the right side panel on the maintenance bypass cabinet.
 - c. Reposition the protections cover to their original position on the right side panel.
 - d. Reposition the two rear brackets and the top bracket on the maintenance bypass cabinet to their original position.
25. Close and lock the front door of the maintenance bypass cabinet.
26. Raise the feet of the maintenance bypass cabinet until the casters have full contact with the floor.
27. You can now move the maintenance bypass cabinet by rolling it over the floor on the casters.

WARNING

TIPPING HAZARD

- The casters of the maintenance bypass cabinet are exclusively for transport on flat, even, hard, and horizontal surfaces.
- The casters of the maintenance bypass cabinet are intended for transport over short distances (i.e. inside the same building).
- Move at a slow pace and pay close attention on the floor conditions and the balance of the maintenance bypass cabinet.

Failure to follow these instructions can result in death, serious injury, or equipment damage.

28. If present, remove the rear seismic anchoring bracket from the maintenance bypass cabinet and remove the seismic anchors from the floor. Save for reinstallation.

29. **For transport over longer distances or in conditions that are not suitable for the casters of the maintenance bypass cabinet:**

⚠ WARNING

TIPPING HAZARD

The maintenance bypass cabinet can tip easily. Take appropriate precautions during handling and preparation for transport/shipment.

Failure to follow these instructions can result in death, serious injury, or equipment damage.

⚠ WARNING

TIPPING HAZARD

For transport over longer distances or in conditions that are not suitable for the casters of the maintenance bypass cabinet, ensure:

- that personnel performing the transport have necessary skill and have received adequate training;
- to use appropriate tools to safely lift and transport the maintenance bypass cabinet;
- to protect the product against damage by using appropriate protection (like wrapping or packaging).

Failure to follow these instructions can result in death, serious injury, or equipment damage.

Transportation requirements:

- Mount the maintenance bypass cabinet in a vertical position in the center of a suitable pallet with minimum pallet dimensions: 1000 mm x 1000 mm (39.4 in x 39.4 in). The pallet must be suitable for the weight of the maintenance bypass cabinet: 158 kg (348 lbs).
- Use appropriate means of fixation to mount the maintenance bypass cabinet to the pallet.
- The original shipping pallet in combination with the original transportation brackets can be reused, if in undamaged condition.

⚠ DANGER

TIPPING HAZARD

- The maintenance bypass cabinet must be appropriately fixed to the pallet immediately after being placed on the pallet.
- The fixation hardware must be strong enough to withstand vibrations and shocks during loading, transport, and unloading.

Failure to follow these instructions will result in death or serious injury.

⚠ WARNING

UNEXPECTED EQUIPMENT BEHAVIOR

Do not lift the maintenance bypass cabinet with a forklift/pallet truck directly on the frame as it may bend or damage the frame.

Failure to follow these instructions can result in death, serious injury, or equipment damage.

30. Perform one of the following:
 - Decommission the maintenance bypass cabinet, OR
 - Move the maintenance bypass cabinet to a new location to install it.
31. **Only for installing the maintenance bypass cabinet in a new location:**
Follow the installation manual to install the maintenance bypass cabinet in the new location. See [Installation Procedure](#), page 16 for installation overview. Startup must only be performed by Schneider Electric.

 **DANGER**

HAZARD OF ELECTRIC SHOCK, EXPLOSION, OR ARC FLASH

Startup must only be performed by Schneider Electric.

Failure to follow these instructions will result in death or serious injury.

Schneider Electric
35 rue Joseph Monier
92500 Rueil Malmaison
France

+ 33 (0) 1 41 29 70 00



As standards, specifications, and design change from time to time,
please ask for confirmation of the information given in this publication.

© 2020 – 2024 Schneider Electric. All rights reserved.

990-91376E-001