

Easy UPS 3S Pro for Internal / External Batteries

10-40 kVA 400 V 3:3 / 10-30 kVA 400 V 3:1

Operation

Latest updates are available on the Schneider Electric website
4/2026



Legal Information

The information provided in this document contains general descriptions, technical characteristics and/or recommendations related to products/solutions.

This document is not intended as a substitute for a detailed study or operational and site-specific development or schematic plan. It is not to be used for determining suitability or reliability of the products/solutions for specific user applications. It is the duty of any such user to perform or have any professional expert of its choice (integrator, specifier or the like) perform the appropriate and comprehensive risk analysis, evaluation and testing of the products/solutions with respect to the relevant specific application or use thereof.

The Schneider Electric brand and any trademarks of Schneider Electric SE and its subsidiaries referred to in this document are the property of Schneider Electric SE or its subsidiaries. All other brands may be trademarks of their respective owner.

This document and its content are protected under applicable copyright laws and provided for informative use only. No part of this document may be reproduced or transmitted in any form or by any means (electronic, mechanical, photocopying, recording, or otherwise), for any purpose, without the prior written permission of Schneider Electric.

Schneider Electric does not grant any right or license for commercial use of the document or its content, except for a non-exclusive and personal license to consult it on an "as is" basis.

Schneider Electric reserves the right to make changes or updates with respect to or in the content of this document or the format thereof, at any time without notice.

To the extent permitted by applicable law, no responsibility or liability is assumed by Schneider Electric and its subsidiaries for any errors or omissions in the informational content of this document, as well as any non-intended use or misuse of the content thereof.

Access to Your Product Manuals Online

Find the UPS Manuals, Submittal Drawings, and Other Documentation for Your Specific UPS Here:

From the main menu on the UPS display, tap **Digital experience** and scan the QR code,

OR

In your web browser, type in <https://www.go2se.com/ref=> and the commercial reference for your product.

Example: <https://www.go2se.com/ref=E3SP10KH>

Find the UPS Manuals, Relevant Auxiliary Product Manuals, and Option Manuals Here:

Scan the QR code to go to the Easy UPS 3S Pro online manual portal:
https://www.productinfo.schneider-electric.com/easyups3s_pro_iec/



Here you can find your UPS installation manual, UPS operation manual, and UPS technical specifications, and you can also find installation manuals for your auxiliary products and options.

This online manual portal is available on all devices and offers digital pages, search functionality across the different documents in the portal, and PDF download for offline use.

Learn More About the Easy UPS 3S Pro Here:

Go to <https://www.se.com/ww/en/product-range/319433188> to learn more about this product.

Table of Contents

Important Safety Instructions — SAVE THESE	
INSTRUCTIONS	7
Electromagnetic Compatibility	8
Safety Precautions	8
Cybersecurity Recommendations	9
Symbols Used in the Product.....	10
Overview of Single UPS.....	11
Overview of 1+1 Redundant Parallel System with Common Battery Bank	12
Overview of Parallel System	14
Overview of User Interface	17
Display	17
Menu Tree.....	20
Location of Disconnect Devices	23
Operation Modes	24
UPS Modes.....	24
System Modes	26
Configuration	27
Set the Display Language	27
Change the Password.....	27
Configure the UPS.....	28
Configure the UPS Input	29
Configure the Rating	30
Configure the UPS Output.....	31
Configure the UPS Bypass	32
View the Battery Solution Configuration.....	33
Configure the Input Contacts	35
Configure the Output Relays	36
Configure the Communication Settings	38
Configure the Network	40
Configure the Display Preferences	41
Set the Date and Time	41
Register the UPS.....	41
Configure the Air Filter Reminder	42
Default Settings for Reference	43
Operation Procedures	44
Transfer the UPS from Normal Operation to Static Bypass Operation.....	44
Transfer the UPS from Static Bypass Operation to Normal Operation.....	45
Turn the Inverter OFF	46
Turn the Inverter ON	47
Set the Charger Mode.....	48
Start Up a Single UPS in Normal Operation	49
Shut Down a Single UPS.....	51

Transfer a Single UPS from Normal Operation to Maintenance Bypass Operation..... 52

Transfer a Single UPS from Maintenance Bypass Operation to Normal Operation..... 56

Transfer a Parallel System from Normal Operation to Maintenance Bypass Operation 57

Transfer a Parallel System from Maintenance Bypass Operation to Normal Operation 58

Isolate a Single UPS from the Parallel System 59

Start Up and Add a UPS to a Running Parallel System 62

View the Logs..... 63

View the System Status Information 64

Maintenance 66

 Recommended Personal Protective Equipment (PPE)..... 66

 Connect the Temperature Sensor Kit (Option)..... 66

 Replace the Air Filter on UPS for Internal Batteries 67

 Replace the Air Filter on UPS for External Batteries 70

 Determine if you need a Replacement Part..... 72

 Replace or Install a Modular Battery String 73

 Find the Serial Numbers..... 75

 Find More Support with Digital Experience 76

 Return Parts to Schneider Electric 77

Troubleshooting 78

 Alarm Messages..... 78

 Export UPS Event Logs to a USB Device..... 83

Appendix: Switch/Circuit Breaker Model Details..... 87

Important Safety Instructions — SAVE THESE INSTRUCTIONS

Read these instructions carefully and look at the equipment to become familiar with it before trying to install, operate, service or maintain it. The following safety messages may appear throughout this manual or on the equipment to warn of potential hazards or to call attention to information that clarifies or simplifies a procedure.



The addition of this symbol to a “Danger” or “Warning” safety message indicates that an electrical hazard exists which will result in personal injury if the instructions are not followed.



This is the safety alert symbol. It is used to alert you to potential personal injury hazards. Obey all safety messages with this symbol to avoid possible injury or death.

DANGER

DANGER indicates a hazardous situation which, if not avoided, **will result in death or serious injury.**

Failure to follow these instructions will result in death or serious injury.

WARNING

WARNING indicates a hazardous situation which, if not avoided, **could result in death or serious injury.**

Failure to follow these instructions can result in death, serious injury, or equipment damage.

CAUTION

CAUTION indicates a hazardous situation which, if not avoided, **could result in minor or moderate injury.**

Failure to follow these instructions can result in injury or equipment damage.

NOTICE

NOTICE is used to address practices not related to physical injury. The safety alert symbol shall not be used with this type of safety message.

Failure to follow these instructions can result in equipment damage.

Please Note

Electrical equipment should only be installed, operated, serviced, and maintained by qualified personnel. No responsibility is assumed by Schneider Electric for any consequences arising out of the use of this material.

A qualified person is one who has skills and knowledge related to the construction, installation, and operation of electrical equipment and has received safety training to recognize and avoid the hazards involved.

Per IEC 62040-1: "Uninterruptible power systems (UPS) -- Part 1: Safety Requirements," this equipment, including battery access, must be inspected, installed and maintained by a skilled person.

The skilled person is a person with relevant education and experience to enable him or her to perceive risks and to avoid hazards which the equipment can create (reference IEC 62040-1, section 3.102).

Electromagnetic Compatibility

NOTICE

RISK OF ELECTROMAGNETIC DISTURBANCE

This is a product category C3 product. In a residential environment, this product may cause radio interference, in which case the user may be required to take additional measures.

Failure to follow these instructions can result in equipment damage.

Safety Precautions

⚡⚠ DANGER

HAZARD OF ELECTRICAL SHOCK, EXPLOSION OR ARC FLASH

All safety instructions in this document must be read, understood and followed.

Failure to follow these instructions will result in death or serious injury.

⚡⚠ DANGER

HAZARD OF ELECTRICAL SHOCK, EXPLOSION OR ARC FLASH











After the UPS system has been electrically wired, do not start up the system. Start-up must only be performed by Schneider Electric.

Failure to follow these instructions will result in death or serious injury.

Cybersecurity Recommendations

- Install the UPS in a location with restricted access.
- Only authorize access to the UPS to maintenance and service personnel.
- Mark the restricted areas with “For authorized personnel only”.
- Record the access to restricted areas with either a physical or an electronic audit trail.

Symbols Used in the Product

	This is the earthing/ground symbol.
	This is the protective earth/equipment grounding conductor symbol.
	This is the direct current symbol. It is also referred to as DC.
	This is the alternating current symbol. It is also referred to as AC.
	This is the positive polarity symbol. It is used to identify the positive terminal(s) of equipment which is used with, or generates direct current.
	This is the negative polarity symbol. It is used to identify the negative terminal(s) of equipment which is used with, or generates direct current.
	This is the battery symbol.
	This is the static switch symbol. It is used to indicate switches that are designed to connect or disconnect the load to or from the supply respectively without the existence of moving parts.
	This is the AC/DC converter (rectifier) symbol. It is used to identify an AC/DC converter (rectifier) and, in case of plug-in devices, to identify the relevant receptacles.
	This is the DC/AC converter (inverter) symbol. It is used to identify an DC/AC converter (inverter) and, in case of plug-in devices, to identify the relevant receptacles.

Overview of Single UPS

UIB	Unit input disconnect device
SSIB	Static switch input disconnect device
UOB	Unit output disconnect device
MBB	Maintenance bypass disconnect device
BB1	Battery disconnect device 1
BB2	Battery disconnect device 2

UPS for Internal Batteries

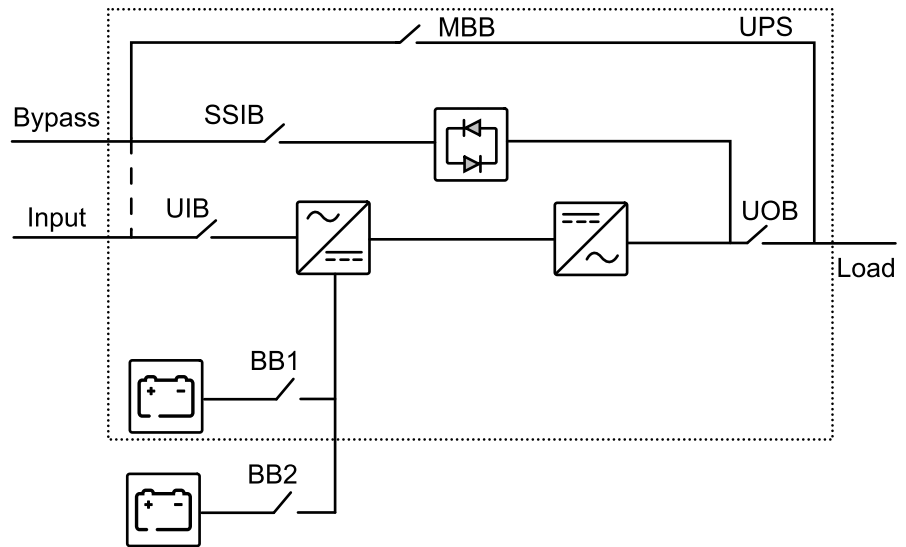

NOTE: Ensure that any external battery matches the internal battery's type and configuration. Schneider Electric offers modular battery modules such as E3SXR6, which are factory-tested to work with the provided internal batteries. To order E3SXR6/E3SXR8 or verify compatibility, please contact Schneider Electric.

UPS for External Batteries

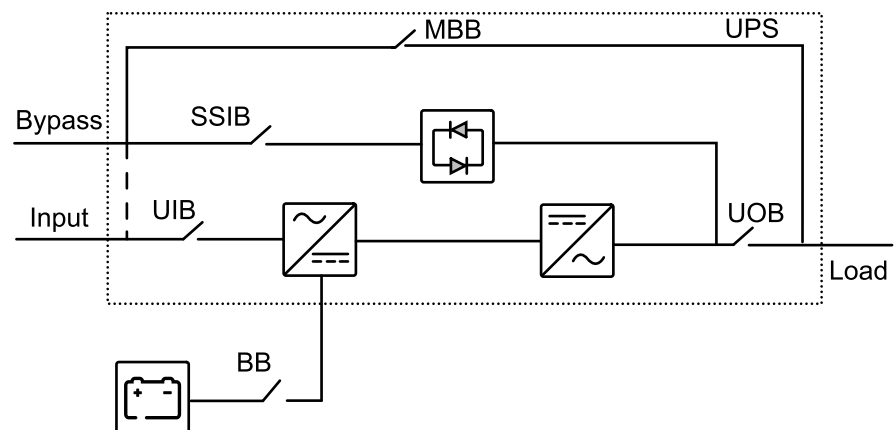

Overview of 1+1 Redundant Parallel System with Common Battery Bank

MIB	Main input disconnect device
BIB	Bypass input disconnect device
UIB	Unit input disconnect device
SSIB	Static switch input disconnect device
UOB	Unit output disconnect device
Ext. UOB	External unit output disconnect device
MBB	Maintenance bypass disconnect device
BB1	Battery disconnect device 1
BB2	Battery disconnect device 2

NOTE: In Schneider Electric literature, 'disconnect device' is used as a generic term covering circuit breakers or switches as their position may vary depending on configuration. Details about the individual configuration are found in the electrical diagram and/or by reading the symbol on the front of each disconnect device.

UPS for Internal Batteries

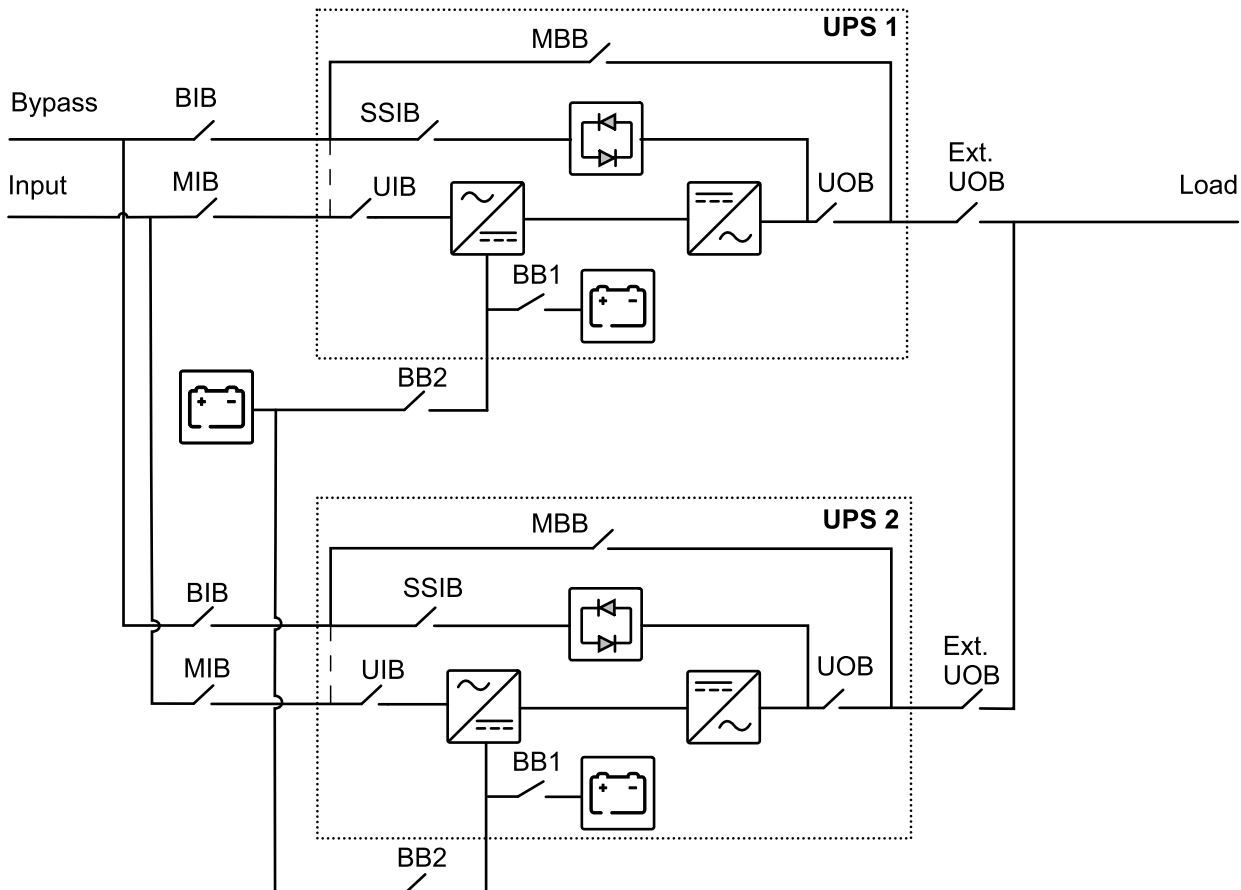

NOTE: Ensure that any external battery matches the internal battery's type and configuration. Schneider Electric offers modular battery modules such as E3SXR6/E3SXR8, which are factory-tested to work with the provided internal batteries. To order E3SXR6/E3SXR8 or verify compatibility, please contact Schneider Electric.

UPS for External Batteries

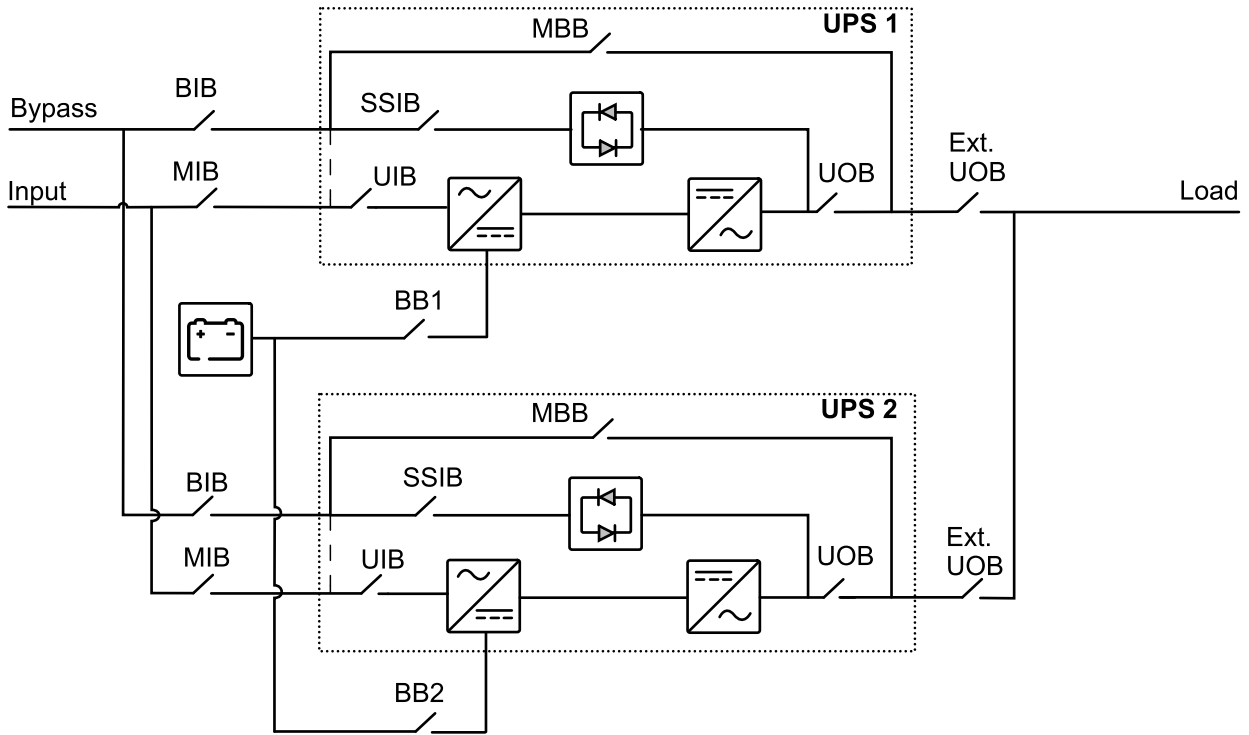

Overview of Parallel System

MIB	Main input disconnect device
BIB	Bypass input disconnect device
UIB	Unit input disconnect device
SSIB	Static switch input disconnect device
UOB	Unit output disconnect device
Ext. UOB	External unit output disconnect device
MBB	Maintenance bypass disconnect device
Ext. MBB	External maintenance bypass disconnect device
SIB	System isolation disconnect device
BB1	Battery disconnect device 1
BB2	Battery disconnect device 2

NOTE: In Schneider Electric literature, 'disconnect device' is used as a generic term covering circuit breakers or switches as their position may vary depending on configuration. Details about the individual configuration are found in the electrical diagram and/or by reading the symbol on the front of each disconnect device.

NOTE: In parallel systems with an external maintenance bypass disconnect device Ext. MBB, the internal maintenance bypass disconnect devices MBB* must be padlocked in the open (OFF) position.

UPS for Internal Batteries

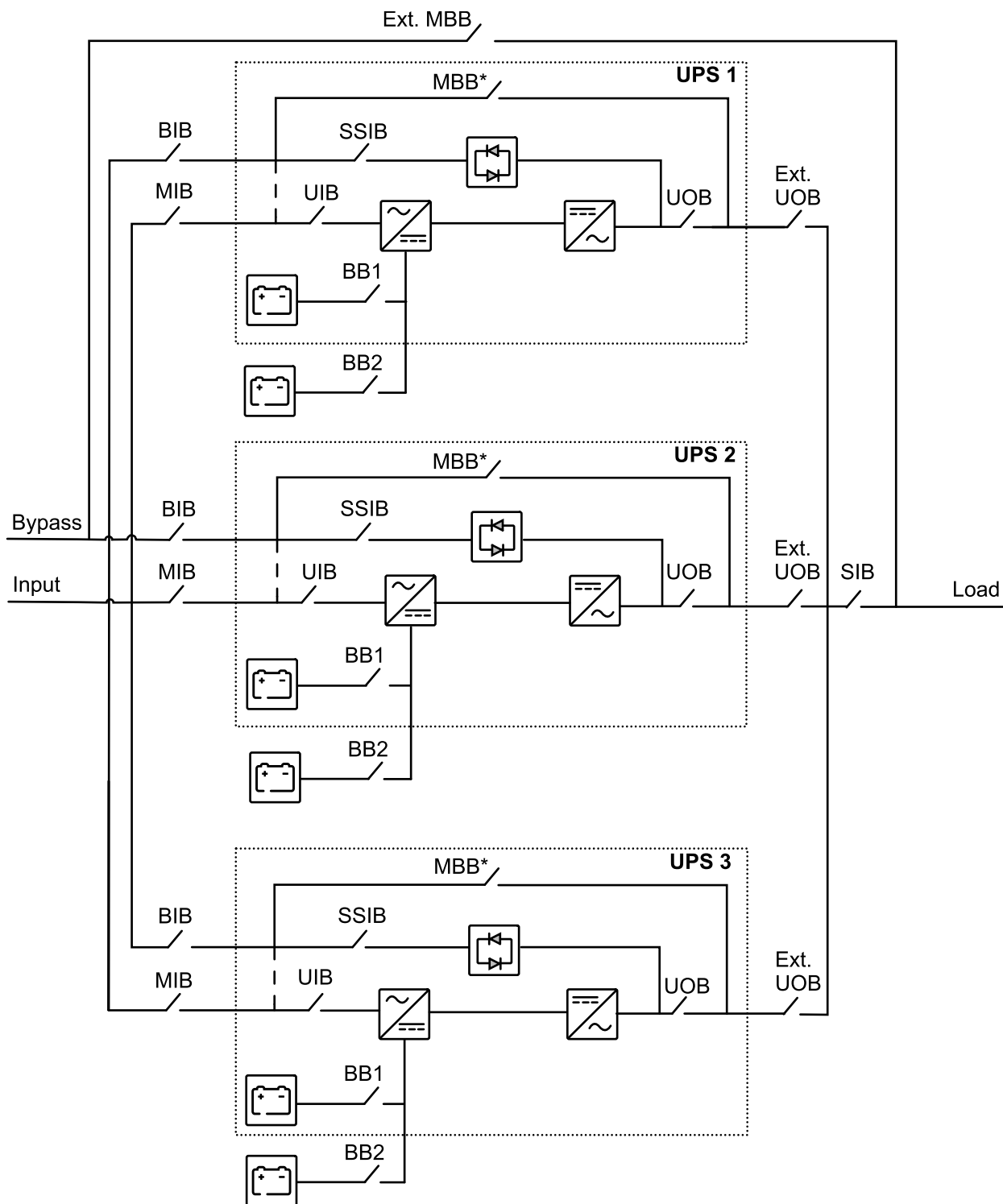

NOTE: Ensure that any external battery matches the internal battery's type and configuration. Schneider Electric offers modular battery modules such as E3SXR6/E3SXR8, which are factory-tested to work with the provided internal batteries. To order E3SXR6/E3SXR8 or verify compatibility, please contact Schneider Electric.

UPS for External Batteries

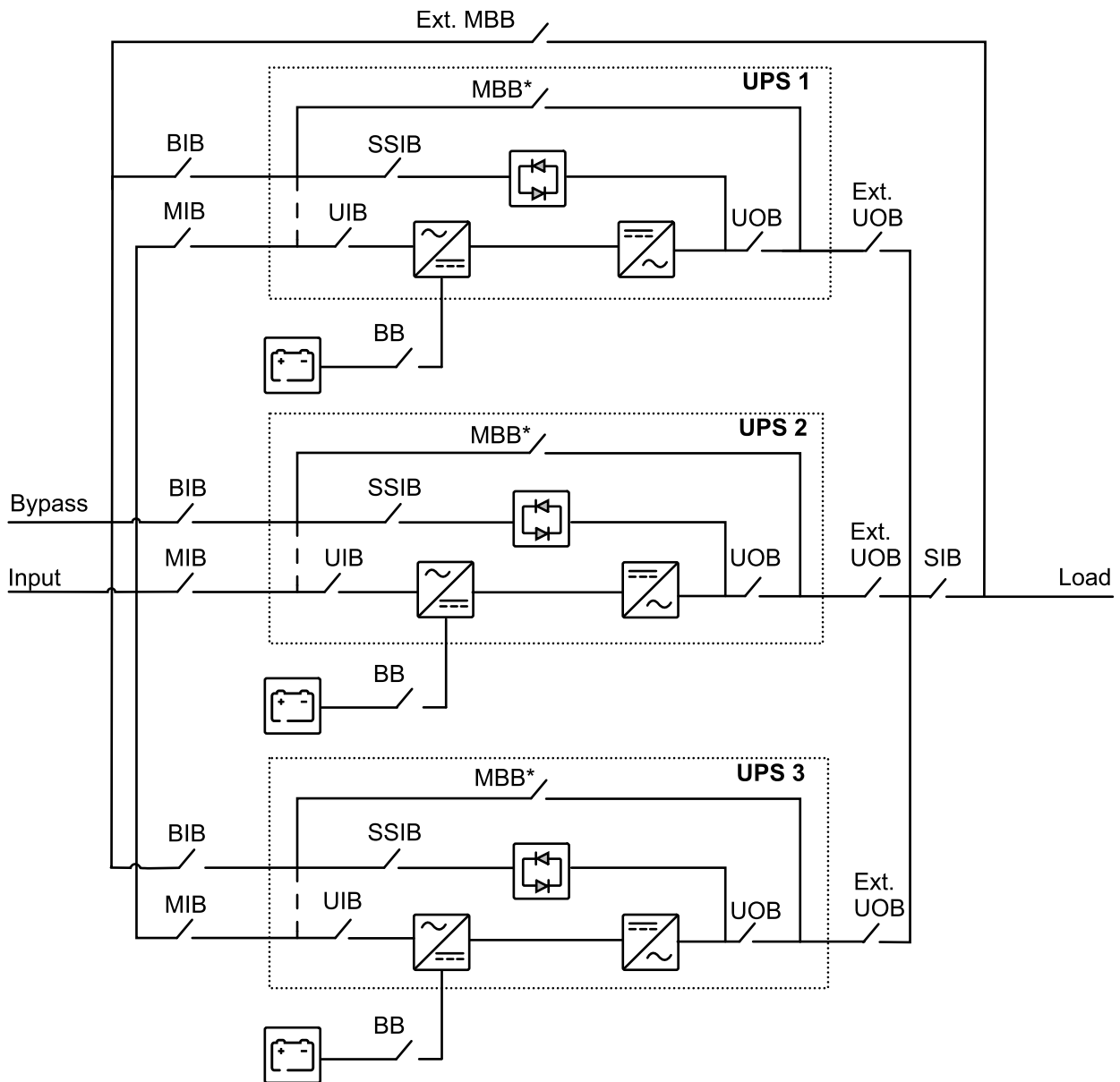

Overview of User Interface

Display

Overview of the Home Screen

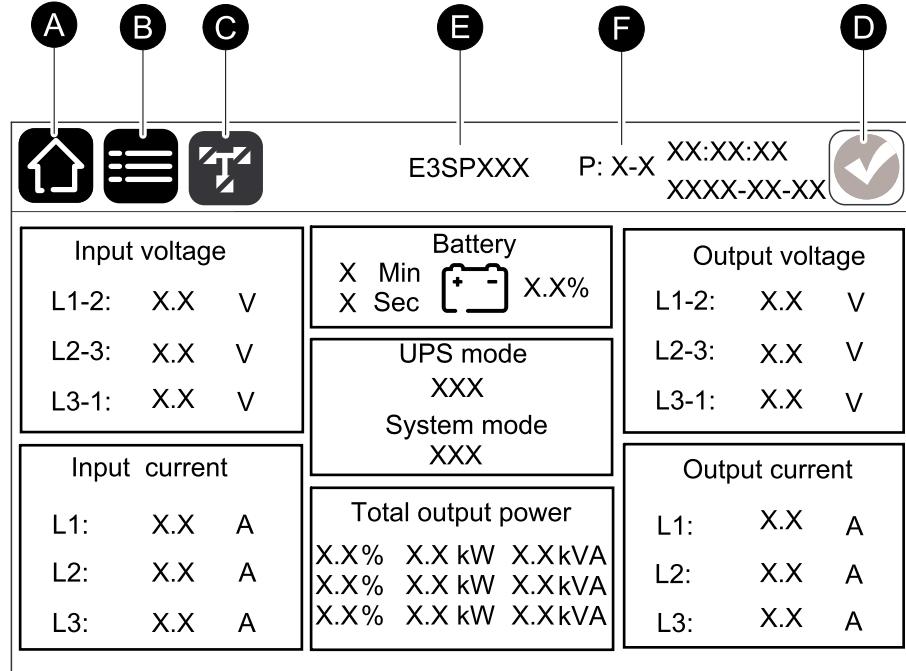

- A. Home button - tap here on any screen to return to the home screen.
- B. Main menu button - tap here to access the menus.
- C. Mimic diagram button - tap here to access the mimic diagram.
- D. Alarm status symbol - tap here to access the active alarms log.
- E. Commercial reference - shows the product commercial reference.
- F. Parallel information - shows the parallel information for a parallel system when **System mode** is set to **Parallel**. The first digit represents the parallel number in a system while the second digit indicates the parallel ID of the current UPS.

You can tap on the input, output, or battery fields on the home screen to go directly to the detailed measurement pages.

Main Menu



Tap the main menu button on the home screen to access the menus.

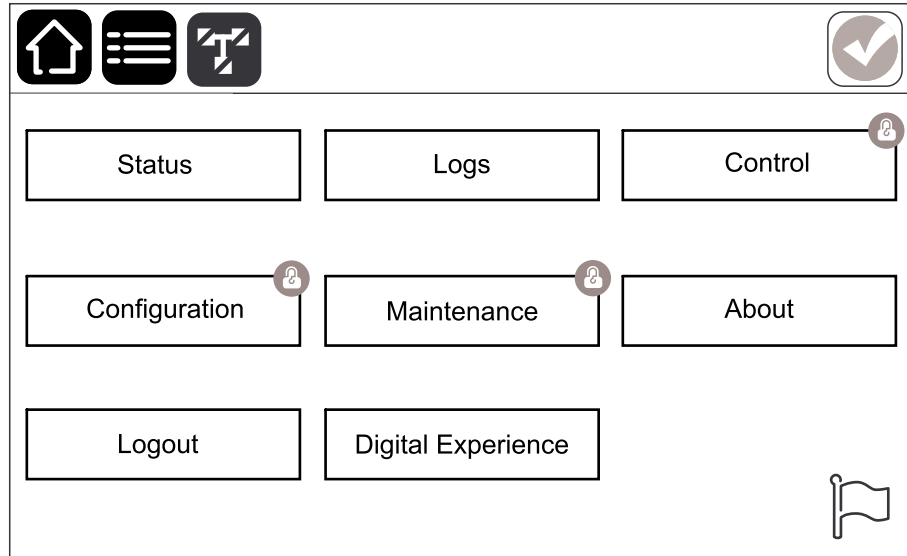

Mimic Diagram

Tap the mimic diagram button on the home screen to access the mimic diagram.

The mimic diagram will adapt to your system configuration – the mimic diagram shown here is just an example.

Example of Single UPS System – Single Mains

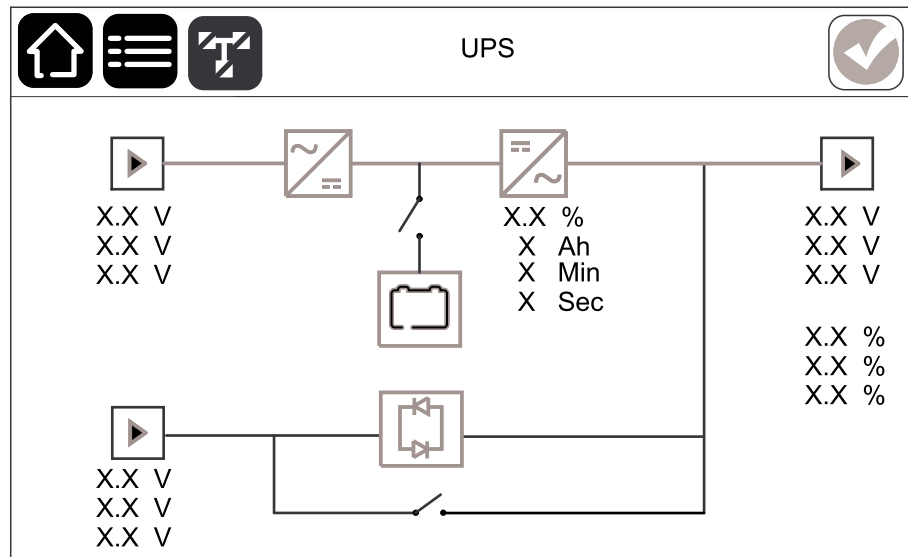

The green power line (gray in illustration) in the mimic diagram shows the power flow through the UPS system. Active modules (inverter, rectifier, battery, static bypass switch, etc.) are framed in green and inactive modules are framed in black. Modules framed in red are inoperable or in an alarm condition.

In mimic diagrams for parallel systems, tap on the gray UPS to see the mimic diagram on UPS level. UPS(s) that are present in the parallel system are framed in gray and those that are not present in the parallel system are framed in white. The numbers after UPS 0-3 represent the individual **Parallel ID** for the UPS.

Example of Parallel System

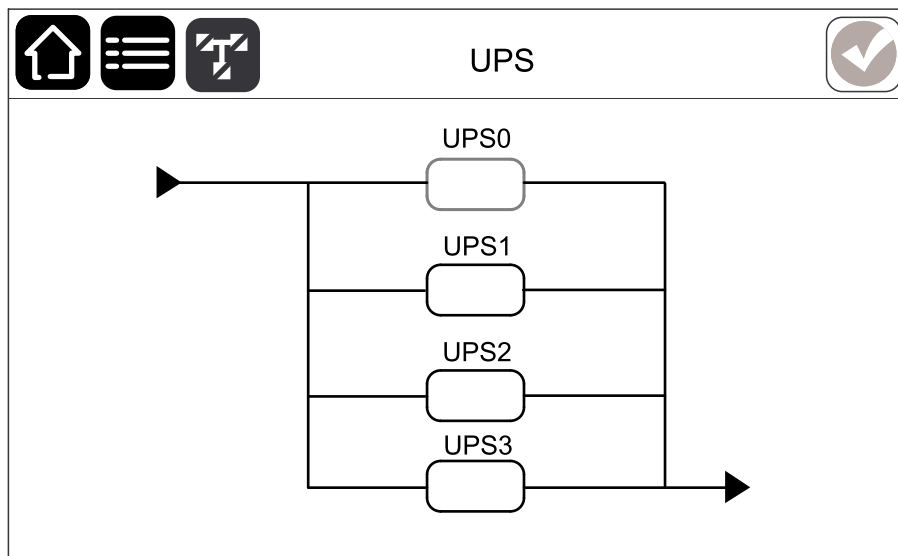

Alarm Status Symbols

The alarm status symbol (gray in illustration) in the top right corner of the display changes depending on the alarm status of the UPS system.

	Green: No alarms present in the UPS system.
	Blue: Informational alarm(s) present in the UPS system. Tap the alarm status symbol to open the active alarms log.
	Yellow: Warning alarm(s) present in the UPS system. Tap the alarm status symbol to open the active alarms log.
	Red: Critical alarm(s) present in the UPS system. Tap the alarm status symbol to open the active alarms log.
	Red: Connection from the display to the UPS is lost.

Menu Tree

Main Menu

- **Status** – see Submenus for Status, page 20.
- **Logs** – see View the Logs, page 63.
- **Control** – see Submenus for Control, page 21.
- **Configuration** – see Submenus for Configuration, page 21.
- **Maintenance** – see Submenus for Maintenance, page 22.
- **About**
- **Logout** – see Change the Password, page 27.
- **Digital experience** – see Find More Support with Digital Experience, page 76.
- Flag button – see Set the Display Language, page 27.

Some menus contain more submenus than described in this manual. These submenus are grayed out and are only for use by Schneider Electric to avoid unwanted load impacts. Other menu items can also be grayed out/not shown on the display if they are not relevant or not released yet for this particular UPS system.

Submenus for Status

- **Status** – see View the System Status Information, page 64.
 - **Input**
 - **Output**
 - **Bypass**
 - **Battery**
 - **Temperature**

Submenus for Control

- **Control⁽¹⁾**
 - **Operation mode**
 - **Transfer to bypass operation** – see Transfer a Single UPS from Normal Operation to Maintenance Bypass Operation, page 52 or Transfer a Parallel System from Normal Operation to Maintenance Bypass Operation, page 57.
 - **Transfer to normal operation** – see Transfer a Single UPS from Maintenance Bypass Operation to Normal Operation, page 56 or Transfer a Parallel System from Maintenance Bypass Operation to Normal Operation, page 58.
 - **Inverter**
 - **Inverter on** – see Turn the Inverter ON, page 47.
 - **Inverter off** – see Turn the Inverter OFF, page 46.
 - **Charger** – see Set the Charger Mode, page 48.
 - **Float**
 - **Boost**
 - **Generic sequences**
 - **Start up UPS system** – see Start Up a Single UPS in Normal Operation, page 49.
 - **Shut down UPS system** – see Shut Down a Single UPS, page 51.
 - **Start up and add UPS to a parallel system** – see Start Up and Add a UPS to a Running Parallel System, page 62.
 - **Isolate a UPS from the parallel system** – see Isolate a Single UPS from the Parallel System, page 59.

Submenus for Configuration

- **Configuration⁽¹⁾**
 - **UPS** – see Configure the UPS, page 28.
 - **Input** – see Configure the UPS Input, page 29.
 - **Output** – see Configure the UPS Output, page 31.
 - **Bypass** – see Configure the UPS Bypass, page 32.
 - **Rating** – see Configure the Rating, page 30.
 - **Battery** – see View the Battery Solution Configuration, page 33.
 - **Communication** – see Configure the Communication Settings, page 38.
 - **Contacts and relays**
 - **Input contact** – see Configure the Input Contacts, page 35.
 - **Output relay** – see Configure the Output Relays, page 36.
 - **Reminders** – see Configure the Air Filter Reminder, page 42.
 - **General**
 - **UPS name** – see Register the UPS, page 41.
 - **Date and time** – see Set the Date and Time, page 41.
 - **Display** – see Configure the Display Preferences, page 41.
 - **Network** – see Configure the Network, page 40.

⁽¹⁾ This menu requires administrator login to access.

Submenus for Maintenance

- **Maintenance**
 - **Buzzer**
 - **Battery** – see Replace or Install a Modular Battery String, page 73.
 - **S-code**
 - **Alarm clear** – see Alarm Messages, page 78.
 - **UPS report** – see Export UPS Event Logs to a USB Device, page 83.

Location of Disconnect Devices

Rear View of 10-20 kVA UPS (Internal Batteries)

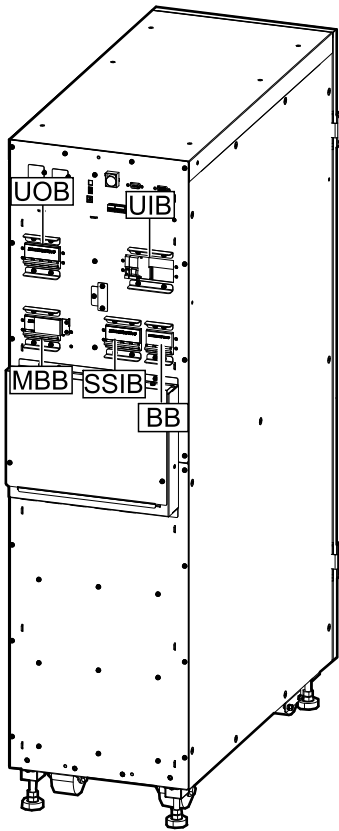

Rear View of 30-40 kVA UPS (Internal Batteries)

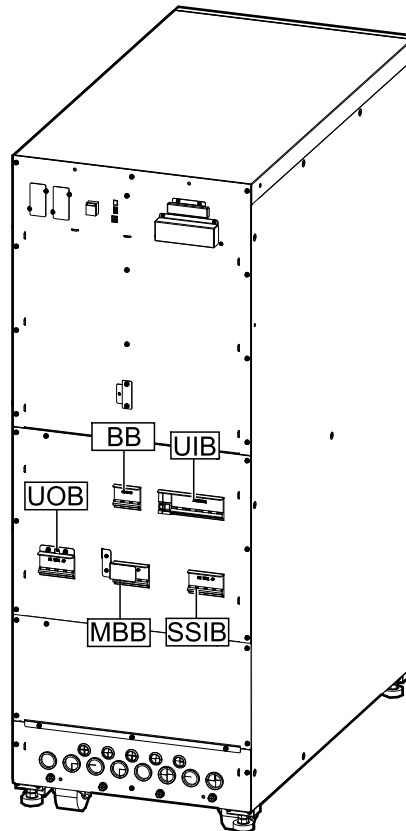

Rear View of 10-20 kVA UPS (External Batteries)

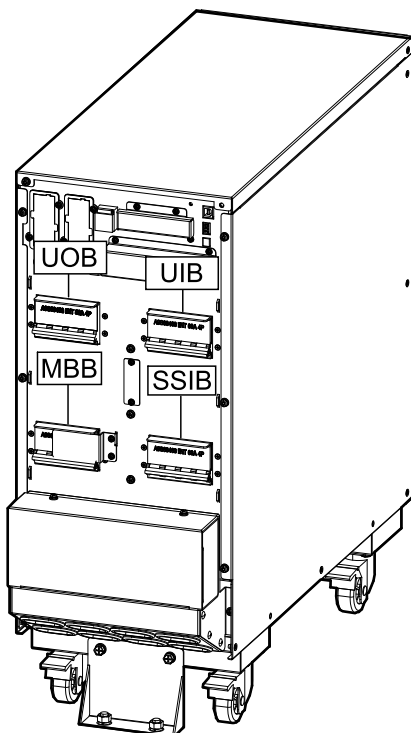

Rear View of 30-40 kVA UPS (External Batteries)

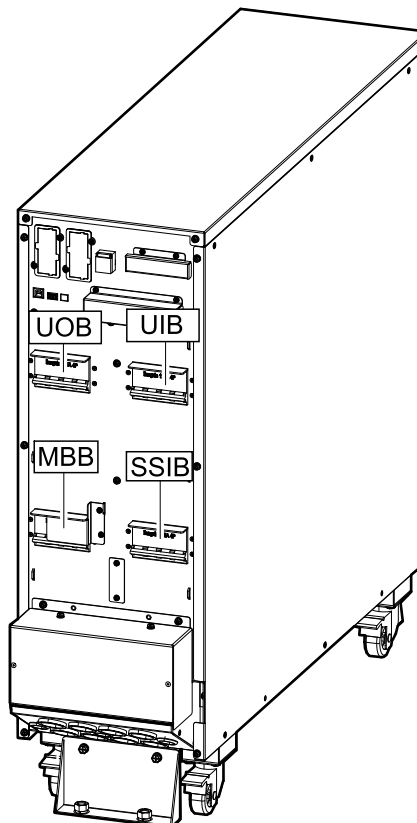

Operation Modes

UPS Modes

Normal Operation

The UPS provides power to the connected load from mains. The UPS converts mains to conditioned power for the connected load while recharging the batteries (float or boost charge).

Battery Operation

The UPS transfers to battery operation if the mains supply fails. The UPS provides power to the connected load from the connected batteries for a finite period. When the mains supply returns, the UPS transfers back to normal operation.

Static Bypass Operation

The UPS supplies the load with power from the bypass source. If the conditions for normal or battery operation are not met, the load will be transferred from the inverter to the bypass source with no interruption in power to the load.

Maintenance Bypass Operation

In maintenance bypass operation, the mains is sent via the external or internal MBB to the load. Battery backup is not available in maintenance bypass operation.

ECO Mode

In ECO mode the UPS is configured to use static bypass operation as the preferred operation mode under predefined circumstances. The inverter is in standby in ECO mode and in case of interruption to the mains, the UPS transfers to battery operation and the load is supplied from the inverter.

NOTE: This mode is disabled by default, please contact Schneider Electric to enable this mode. If ECO mode is enabled, you cannot exit this operation mode by using the display, please also contact Schneider Electric for assistance.

OFF Mode

The UPS is not supplying the load with power. The batteries are charged and the display is on.

Frequency Converter Mode

In frequency converter mode, the UPS presents a stable output frequency (at 50 or 60 Hz) and static bypass is not available.

NOTICE

RISK OF EQUIPMENT DAMAGE OR LOAD DROP

In frequency converter mode the UPS cannot run in static bypass operation or maintenance bypass operation. Before turning the UPS into frequency converter mode, you must contact a Schneider Electric-certified partner to make sure that:

- the SSIB and the MBB are in the OFF (opened) position (Schneider Electric strongly recommends to lock these with a padlock available from Schneider Electric)
- no cables are connected to the bypass terminals

Failure to follow these instructions can result in equipment damage.

System Modes

The system mode indicates the output status of the complete UPS system including the surrounding switchgear and indicates which source supplies the load.

Inverter Operation

In inverter operation the load is supplied by the inverters. The UPS mode can be in either normal operation or battery operation when the system operation mode is inverter operation.

Static Bypass Operation

The UPS supplies the load with power from the bypass source. If the conditions for normal operation or battery operation mode are not met, the load will be transferred from the inverter to the bypass source with no interruption in power to the load.

Maintenance Bypass Operation

In maintenance bypass operation, the load is supplied directly by the bypass source with unconditioned power.

NOTE: The batteries are not available as an alternate power source in maintenance bypass operation.

ECO Mode

ECO mode allows the system to be configured to use requested static bypass operation, with the load supplied through the bypass, as the preferred operation mode under predefined circumstances. The main advantage of ECO mode is a reduction in the consumption of electrical power. In case of interruption to the utility/mains supply, the UPS transfers to inverter operation for an uninterrupted supply of the load.

OFF Mode

The system is not supplying the load with power. The batteries are charged and the display is on.

Configuration

Set the Display Language

1. Tap the flag button on the main menu screen.



2. Tap your language.

Change the Password

NOTE: Always change your password on your first login and keep the password in a secure location.

1. From the main menu, tap **Logout**.
2. Tap **Configuration**.
3. Tap **Change password**.
4. Enter the old password and the new password, tap **Change**.

NOTE: The default administrator user name is **admin** and password is **Easy2401**.

Configure the UPS

NOTE: This configuration is mandatory for correct UPS operation.



1. From the main menu, tap **Configuration > UPS**.
 - a. Set **System mode** to **Single, Parallel, Single ECO, Parallel ECO** or **Self-aging**, default is **Single**.
 - b. Set **Parallel number** to **1, 2, 3, or 4**, default is **1**.
 - c. Set **Parallel ID** to **0, 1, 2, or 3**, default is **0**.
 - d. Set **Slew rate** to **0.5 Hz/s, 1.0 Hz/s, 1.5 Hz/s, or 2.0 Hz/s**, default is **2.0 Hz/s**.
 - e. Set **System autostart mode after EOD** to **Normal, Only bypass, or No output**, default is **Normal**. When **System autostart mode after EOD** has been enabled, the inverter will start up automatically when input voltage returns, after a shutdown due to drained battery.

⚠ ⚠ WARNING

HAZARD OF ELECTRIC SHOCK, EXPLOSION, OR ARC FLASH

Always perform correct Lockout/Tagout before working on the UPS. A UPS with autostart enabled will automatically restart when the mains supply returns.

Failure to follow these instructions can result in death, serious injury, or equipment damage.

Configuration

UPS



System mode	X
Parallel number	X
Parallel ID	X
Slew rate	X
System autostart mode after EOD	X

OK

Cancel

2. Tap **OK** to save your settings.

Configure the UPS Input

NOTE: This configuration is mandatory for correct UPS operation.

1. From the main menu, tap **Configuration > Input**.
 - a. Set **Rated input voltage** to **220 V**, **230 V** or **240 V**, default is **230 V**.
 - b. Set **Rated input frequency** to **50 Hz** or **60 Hz**, default is **50 Hz**.

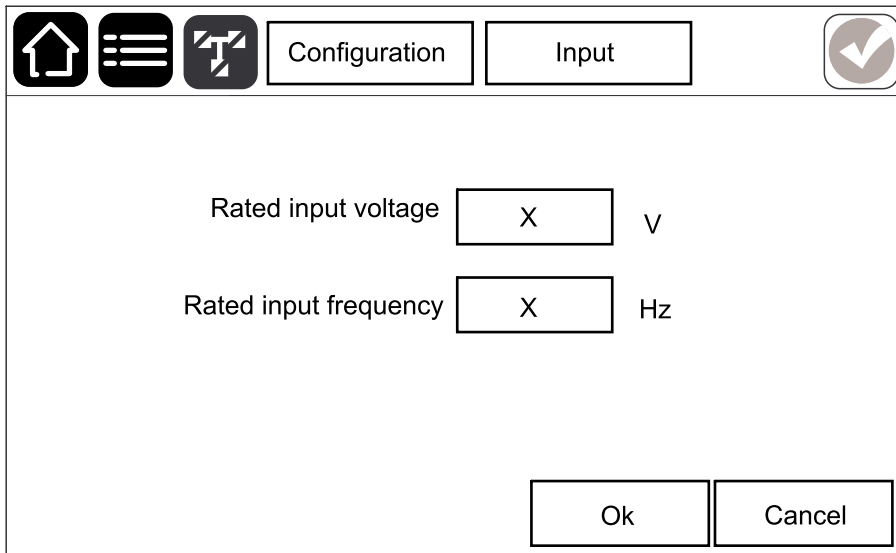

The screenshot shows a mobile application interface for configuring the UPS input. At the top, there is a navigation bar with icons for home, menu, and a specific function, followed by two tabs: 'Configuration' and 'Input'. The 'Input' tab is active. Below the navigation bar, there are two rows of configuration options. The first row is 'Rated input voltage' with a dropdown menu showing 'X' and the unit 'V'. The second row is 'Rated input frequency' with a dropdown menu showing 'X' and the unit 'Hz'. At the bottom right, there are two buttons: 'Ok' and 'Cancel'.

2. Tap **OK** to save your settings.

Configure the Rating

NOTE: This configuration is mandatory for correct UPS operation.

1. From the main menu, tap **Configuration > Rating**.
 - a. Set **Rated output voltage** to **220 V**, **230 V**, or **240 V**, default is **230 V**.
 - b. Set **Rated output frequency** to **50 Hz** or **60 Hz**, default is **50 Hz**.

NOTE: The **Rated power** is not configurable.

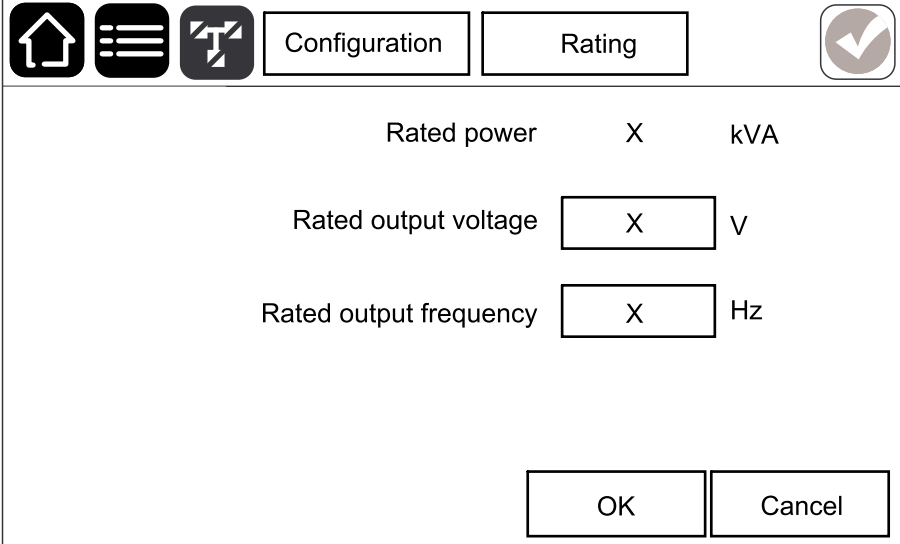

Rated power X kVA

Rated output voltage X V

Rated output frequency X Hz

OK Cancel

2. Tap **OK** to save your settings.

Configure the UPS Output

NOTE: This configuration is mandatory for correct UPS operation when it is powered on for the first time.

1. From the main menu, tap **Configuration > Output**.
 - a. Set **Adjusted output voltage**. The adjusted output voltage range is the rated output voltage ± 10 V, default is **230 V**.
 - b. Set **Synchronization window**. The synchronization window range is 0.5 - 5 Hz, default is **3 Hz**.

The screenshot shows a mobile application interface for configuring the UPS output. At the top, there is a navigation bar with a home icon, a menu icon, a refresh icon, and two tabs: 'Configuration' and 'Output'. Below the navigation bar, there are two input fields. The first is labeled 'Adjusted output voltage' and has a text box containing 'X' followed by 'V'. The second is labeled 'Synchronization window' and has a text box containing 'X' followed by 'Hz'. At the bottom right of the screen, there are two buttons: 'OK' and 'Cancel'.

2. Tap **OK** to save your settings.

Configure the UPS Bypass

NOTE: This configuration is mandatory for correct UPS operation.

1. From the main menu, tap **Configuration > Bypass**.
 - a. Set **Maximum threshold of bypass voltage** to **+10%**, **+15%**, **+20%**, or **+25%**, default is **+10%**.
 - b. Set **Minimum threshold of bypass voltage** to **-10%**, **-15%**, **-20%**, **-30%**, or **-40%**, default is **-10%**.
 - c. Set **Bypass frequency limit** to **+/-1 Hz**, **+/-3 Hz**, or **+/-5 Hz**, default is **+/-3 Hz**.

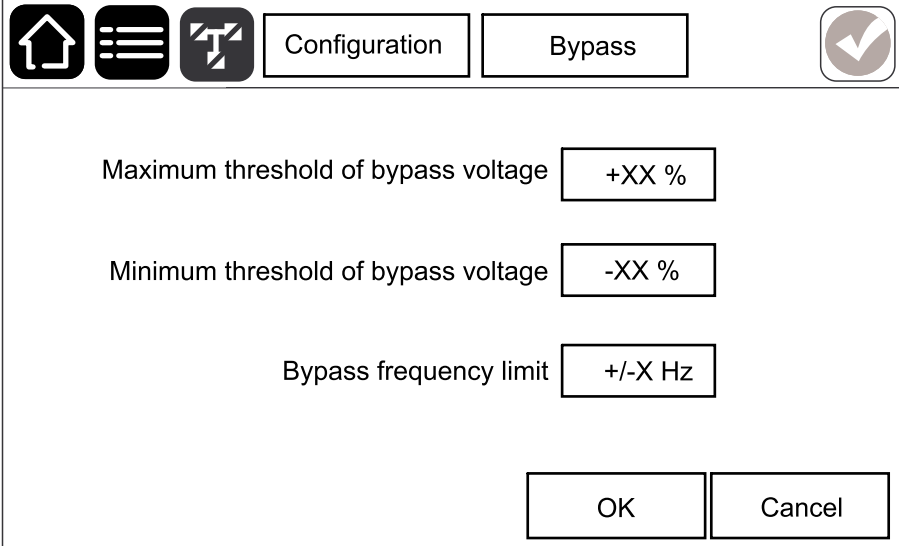

Configuration Bypass

Maximum threshold of bypass voltage

Minimum threshold of bypass voltage

Bypass frequency limit

OK Cancel

2. Tap **OK** to save your settings.

View the Battery Solution Configuration

1. From the main menu, tap **Configuration > Battery**.
2. View the battery settings on the display. Tap the arrow symbol to go to the next page.

NOTE: The battery settings are only configurable by a Schneider Electric Services Representative.

Configuration

Battery

Battery type VRLA

Battery number

Battery capacity Ah

Float charge voltage/cell V

←
1/3
→

Ok

Cancel

Configuration

Battery

EOD voltage/cell, @3C current V

EOD voltage/cell, @0.05C current V

Charge power percent limit %

Charger sleep time Min

Allow boost charge

←
2/3
→

Ok

Cancel

Configuration

Battery

Charge current limitation by Ah

←
3/3
→

Ok

Cancel

Battery type	Shows the battery type: VRLA .
Battery number	Shows the number of battery cells. The battery number can be set to 32, 34, 36, 38, or 40, default is 40.
Battery capacity	Shows the total battery capacity (string quantity x Ah/string), default is 20 Ah.
Float charge voltage/cell	Shows the float voltage per battery cell. Float charging is the basic charging function available on all types of batteries and automatically initiated by the charger. The range for float charge voltage/cell is 2.10-2.35 V, default is 2.25 V.
Boost charge voltage/cell	Shows the boost voltage per battery cell. Boost charging makes it possible to conduct a fast charging in order to quickly restore a discharged battery. The range for boost charge voltage/cell is 2.20 - 2.45 V, default is 2.25 V.
Charge power percent limit	Shows the maximum percentage of the charging power. The range for charge power percent limit varies ⁽²⁾ , default is 10%.
Charge current limitation by Ah	Shows the charge current limitation according to the Ah ratio. The limited current can be set to 0.10 C, 0.15 C, 0.20 C, or 0.25 C, default is 0.25 C.
Charge sleep time	Shows the sleep time for charging. The range for the charge sleep time is 3 - 14400 minutes, default is 3 minutes. When the battery reaches the target voltage, charging will automatically stop based on the pre-set charge sleep time.
EOD voltage/cell at 3C current	Shows the EOD voltage per battery cell for 3C current. The range for EOD voltage/cell at 3C current is 1.6-1.85 V, default is 1.65 V.
EOD voltage/cell at 0.05C current	Shows the EOD voltage per battery cell for 0.05C current. The range for EOD voltage/cell at 0.05C current is 1.65-1.90 V, default is 1.75 V.
Allow boost charge	Shows if boost charge is allowed. Boost charging makes it possible to conduct a fast charging in order to quickly restore a discharged battery. The default setting is Disable .

3. Tap **OK** to save your settings.

(2) Range for charge current percent limit: 1-30% for 10 kVA UPS; 1-26% for 15 kVA UPS; 1-20% for 20 kVA UPS; 1-26% for 30 kVA UPS; 1-20% for 40 kVA UPS.

Configure the Input Contacts

- From the main menu, tap **Configuration > Contacts and relays** and select the input contact that you want to configure.

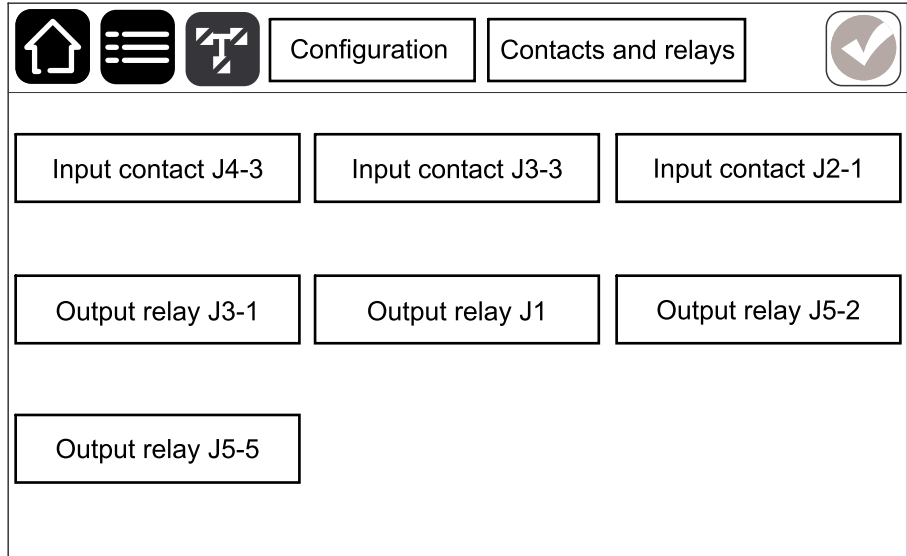

- Select a function from the drop-down list for the selected input contact:

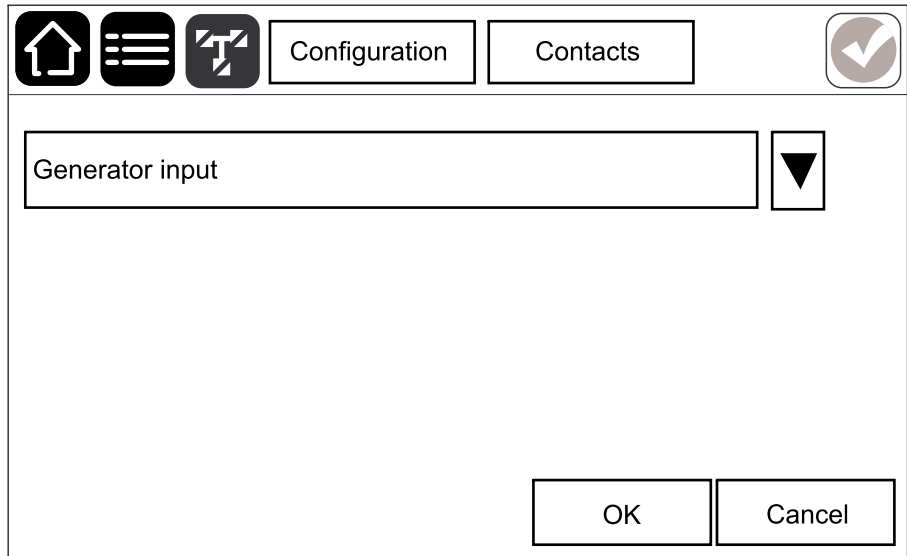

Generator input: The generator has been connected with the system.	Alarm cleared: The alarm is cleared.
MBB contact NO: The maintenance bypass disconnect device MBB is closed (normally open contacts).	Battery over charge: The battery is overcharged and charging is prohibited.
Mute: The buzzer is muted.	Battery over discharge: The battery is over discharged and discharging is prohibited
BB status ⁽³⁾ : Shows the status of the battery disconnect device.	Electrolyte leakage: Indicates an electrolyte leakage.
Transfer inverter: The UPS is transferred to inverter operation.	MBB contact NC: The maintenance bypass disconnect device MBB is closed (normally closed contacts).
Transfer bypass: The UPS is transferred to bypass operation.	Surge protection abnormal: The surge protection is abnormal. ⁽⁴⁾
Turn off charger: The charger is turned off.	UIB open: The status of UIB is OPEN. ⁽⁵⁾

⁽³⁾ The prerequisite for this function to enable **BB present** via Tuner.

⁽⁴⁾ For E3SP15KHIN, E3SP20KHIN, E3SP30KHIN, E3SP40KHIN, E3SP15K3IIN, E3SP20K3IIN, or E3SP30K3IIN, the default function for J4-3 is surge protection abnormal.

⁽⁵⁾ For E3SP10KHB, E3SP15KHB, E3SP20KHB, E3SP30KHB, E3SP40KHB, E3SP10K3IB, E3SP15K3IB, E3SP20K3IB, or E3SP30K3IB, the default function for J3-3 is UIB open.

- On each page, tap **OK** to save your settings and tap the arrow symbol to go to the next page.

Configure the Output Relays

- From the main menu, tap **Configuration > Contacts and relays** and select the output relay that you want to configure.

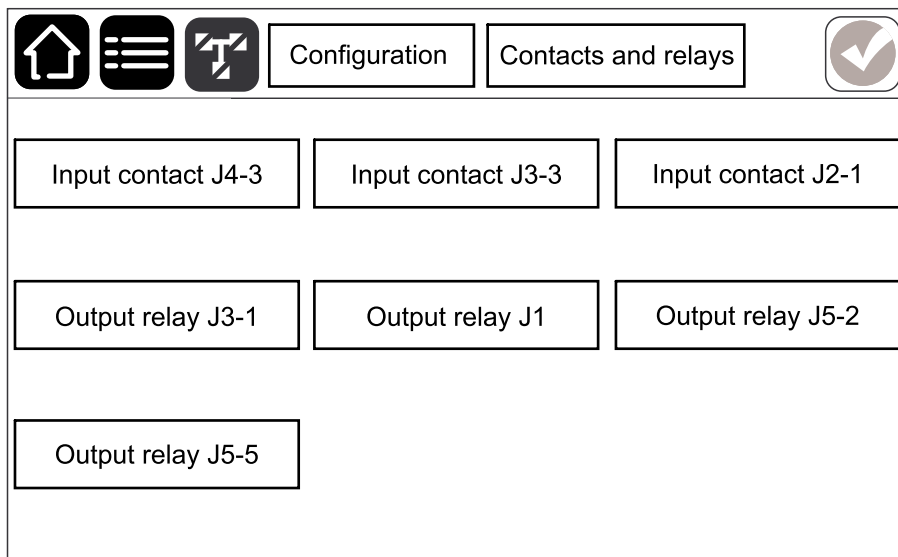

- Select the function(s) you want to assign to the output relay. On each page, tap **OK** to save your settings and tap the arrow symbol to go to the next page.

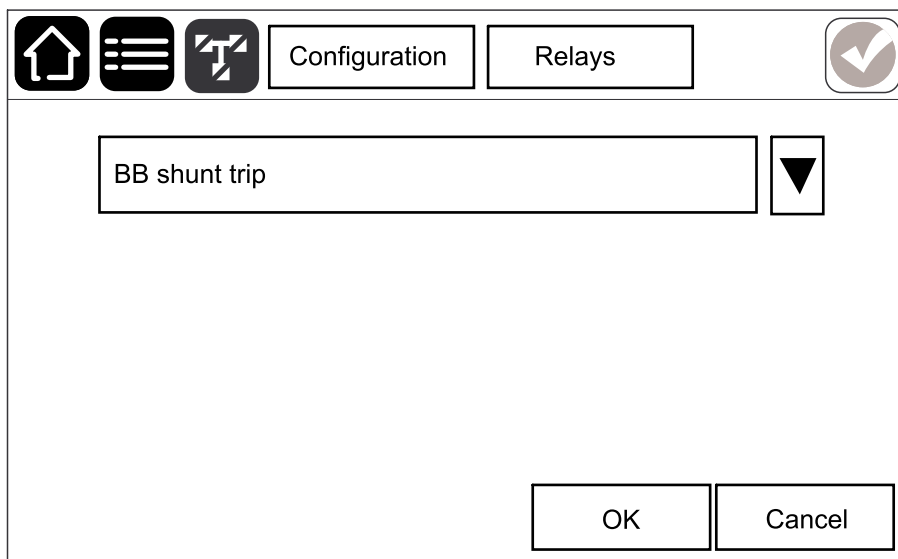

NOTE: It is possible to assign several functions to the same output relay.

Battery charge: When the battery enters the equalization or float charge, the dry contact signal is activated via a relay.	Battery discharge: When the battery starts discharging, the dry contact signal is activated via a relay.
Battery voltage low: When the battery is in low voltage, the dry contact signal is activated via a relay.	Battery mode: When the UPS is in battery discharge mode, the dry contact signal is activated via a relay.
BB shunt trip: When a battery-related alarm occurs, the UPS will send a signal to disconnect the battery, and simultaneously, an auxiliary dry contact signal will be activated via a relay.	BB under voltage trip: When a battery-related alarm occurs, the dry contact signal (24 V) is activated via a relay to disconnect the external battery disconnect device.
Bypass backfeed trip: When the bypass backfeed occurs, the UPS will trigger an alarm to indicate the bypass fault, and simultaneously, an auxiliary dry contact signal will be activated via the isolation of a relay.	EPO active: When the EPO is activated, a dry contact signal is activated via a relay.
General alarm: When one or more warnings are triggered, an auxiliary dry contact signal is activated via the isolation of a relay.	Main power supply not available: In an event of mains abnormality, a dry contact signal is activated via a relay.
Main backfeed trip: When the mains backfeed occurs, the UPS will trigger an alarm to indicate the mains fault, and simultaneously, an auxiliary dry contact signal will be activated via the isolation of a relay. ⁽⁶⁾	Normal mode: When the UPS is in normal operation mode, the dry contact signal is activated via a relay.
On bypass: When the UPS is in bypass operation mode, the dry contact signal is activated via a relay.	On inverter: When the UPS is in inverter mode, the dry contact signal is activated via a relay.
Overload: When the UPS is overloaded, a dry contact signal will be activated via a relay. It is mandatory to set this function when the UPS is powered on for the first time.	Output lost: When the load is disconnected, a dry contact signal is activated via a relay.
Rectifier ready: When the rectifier is ready, the dry contact signal is activated via a relay.	

3. Tap **OK** to save your settings.

⁽⁶⁾ For E3SP10KHB, E3SP15KHB, E3SP20KHB, E3SP30KHB, E3SP40KHB, E3SP10K3IB, E3SP15K3IB, E3SP20K3IB, or E3SP30K3IB, the default function for J5-2 is **Main backfeed trip**.

Configure the Communication Settings

- From the main menu, tap **Configuration > Communication** to configure communication settings for **Modbus/USB** or **NMC**.

NOTE: The communication port CAN is reserved for future use.

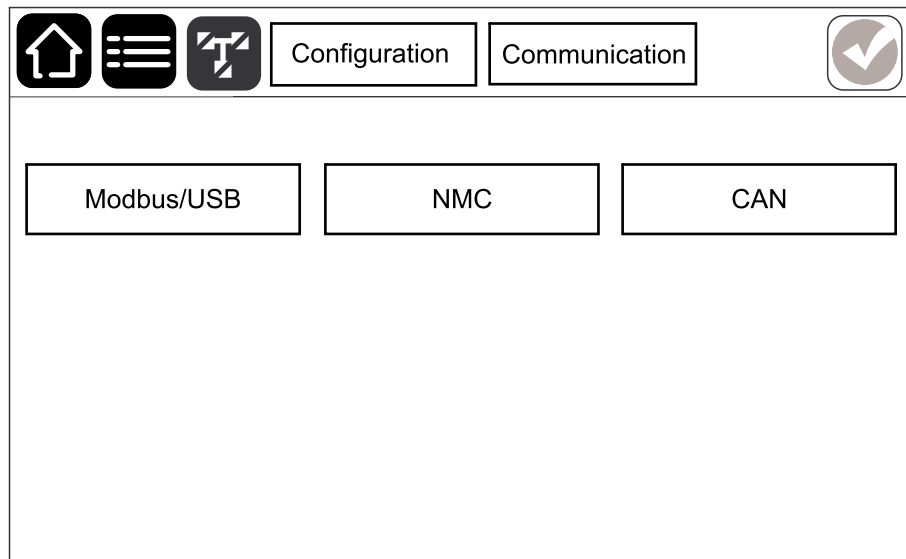

- Tap **Modbus/USB** to configure the communication settings when the UPS received communication via the USB port.
 - Set the **Communication protocol** to **Modbus** or **Tuner**, default is **Tuner**.
 - Set the **Communication mode** to **RTU** or **ASCII**. If **Tuner** is selected in **Communication protocol**, the default setting for **Communication mode** is **ASCII** and is not configurable.
 - Set the **Baud rate** to **1200**, **2400**, **4800**, **9600**, **14400**, or **19200**, default is 9600. If **Tuner** is selected in **Communication protocol**, the **Baud rate** is **9600** and is not configurable.
 - Set the **Device address**. The device address range is 1-255. If **Tuner** is selected in **Communication protocol**, the **Device address** is **1** and is not configurable.
 - Tap **OK** to save your settings.

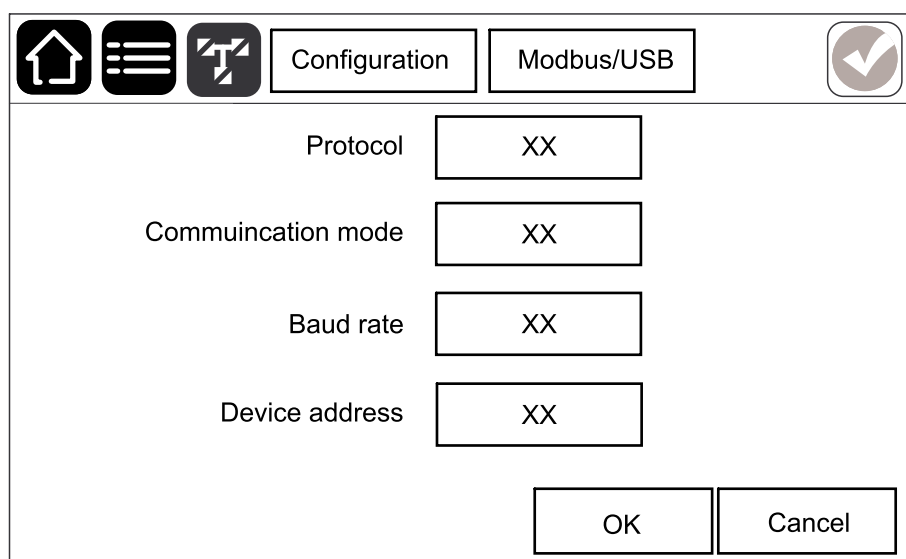

3. Tap **NMC** to configure the communication settings when the UPS received communication via the NMC port.
 - a. Remove the check mark for **Disable** to configure the **TCP Modbus**. When the check mark is present, no settings can be made and the function is disabled.
 - b. Select **Port 502** or **Port [5000 to 32768]**.
 - c. Tap **OK** to save your settings.

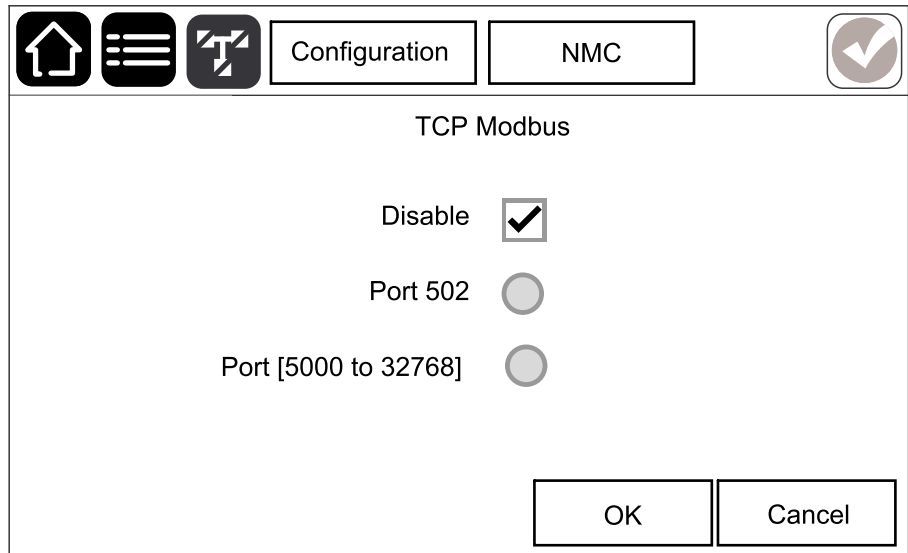

The screenshot shows a mobile application interface for configuring the NMC (Network Modbus Controller) settings. The title bar at the top contains a home icon, a menu icon, a refresh icon, and two buttons labeled "Configuration" and "NMC". A checkmark icon is visible in the top right corner of the screen. The main content area is titled "TCP Modbus" and contains three settings:



- Disable**: A checkbox that is currently checked (indicated by a checkmark).
- Port 502**: A radio button that is currently unselected.
- Port [5000 to 32768]**: A radio button that is currently unselected.

At the bottom right of the screen, there are two buttons: "OK" and "Cancel".

Configure the Network

The network can be configured for the integrated and the optional network management card (NMC).

1. Configure the IPv4 settings on the page for the chosen NMC:

Configuration

Network



Disable integrated NMC IPv4

Address mode Manual DHCP BOOTP

System IP	x	x	x	x
Subnet mask	x	x	x	x
Default gateway	x	x	x	x

OK

Cancel

- a. Remove the check mark for **Disable integrated NMC IPv4/Disable optional NMC IPv4** to configure the **IPv4**. When the check mark is present, no settings can be made and the function is disabled.
- b. Set the **Address mode** to **Manual**, **DHCP**, or **BOOTP**. For manual address mode, add the values.
- c. Tap **OK** to save your settings.

Configure the Display Preferences

1. From the main menu, tap **Configuration > General > Display**.
 - a. Set the **Start screen saver after (minutes)**. After the set minutes of no activity, the screen saver will begin on the display.
 - b. Tap the - or + to set the display brightness.
 - c. Set the **Alarm sound** to **Enable** or **Disable**. This will enable/mute all alarm sounds.
 - d. Set the **Touch screen sound** to **Enable** or **Disable**. This will enable/mute all display sounds (excluding alarm sounds).
 - e. Tap the **Calibration** button twice to calibrate the display.
2. Tap **OK** to save your settings.

Set the Date and Time

1. From the main menu, tap **Configuration > General > Date and time**.
2. Set the **Year, Month, Day, Hour, Minute, and Second**.
3. Tap **OK** to save your settings.

Register the UPS

1. From the main menu, tap **Configuration > General > Registration code**.
2. Contact Schneider Electric customer support to obtain your registration code. Enter your registration code on the display.
3. Tap **OK** to save your settings.

Configure the Air Filter Reminder

When the air filter has been replaced, reset the air filter reminder.

1. From the main menu, tap **Configuration > Reminders**.
 - a. Set the reminder interval in the field **Duration before 1st reminder** based on the installation room environment, default is 360 days.
Under **Used days** you can see how many days the filter has been in use.
 - b. Tap **OK** to save your settings.

Air filter check

Duration before 1st reminder (Days)

Used days

Reset air filter counter

OK Cancel

Default Settings for Reference

Setting	Default Value	Available Settings
Date and time	01/01/2025 10:00:00	Year > 2000
Language	English	12 available languages
System mode	Single	Single, Parallel, Single ECO, Parallel ECO or Self-aging ⁽⁷⁾
Parallel number	1	1, 2, 3 or 4
Parallel ID	0	0, 1, 2 or 3
Slew rate	2.0 Hz/s	0.5 Hz/s, 1.0 Hz/s, 1.5 Hz/s, or 2.0 Hz/s
System autostart mode after EOD	Normal	Normal, Only bypass, or No output
Rated input voltage(LN) ⁽⁷⁾	230 V	220 V / 230 V / 240 V
Rated input frequency ⁽⁷⁾	50 Hz	50 Hz / 60 Hz
Rated output voltage(LN) ⁽⁷⁾	230 V	220 V / 230 V / 240 V
Rated output frequency ⁽⁷⁾	50 Hz	50 Hz / 60 Hz
Adjusted output voltage	230 V	Rated output voltage ± 10 V
Synchronization window	3Hz	0.5-5 Hz
Maximum threshold of bypass voltage	+10%	+10%, +15%, +20%, or +25%
Minimum threshold of bypass voltage	-10%	-10%, -15%, -20%, -30%, or -40%
Bypass frequency limit	+/-3 Hz	+/-1 Hz, +/-3 Hz, or +/-5 Hz
Battery number	40	32, 34, 36, 38, or 40
Battery capacity	20Ah	0.1 to 3000Ah
Float charge voltage/cell	2.25 V	2.10-2.35 V
Boost charge voltage/cell	2.25 V	2.20-2.45 V
EOD voltage/cell at 3C current	1.65 V	1.6-1.85 V
EOD voltage/cell at 0.05C current	1.75V	1.65-1.90 V
Charger sleep limit	3 min	3–14400 minutes
Allow boost charge	Disable	Enable / Disable
Charger current limitation by Ah	0.25 C	0.10 C, 0.15 C, 0.20 C, 0.25 C
Communication protocol	Tuner	Modbus / Tuner
Communication mode	ASCII	RTU / ASCII
Baud rate	9600	1200, 2400, 4800, 9600, 14400, or 19200
Device address	1	1-255
Duration before 1st reminder	360 days	/

⁽⁷⁾ The UPS needs to get restarted after this setting is configured.

Operation Procedures

Transfer the UPS from Normal Operation to Static Bypass Operation

1. From the main menu, tap **Control > Operation mode > Transfer to bypass operation**.

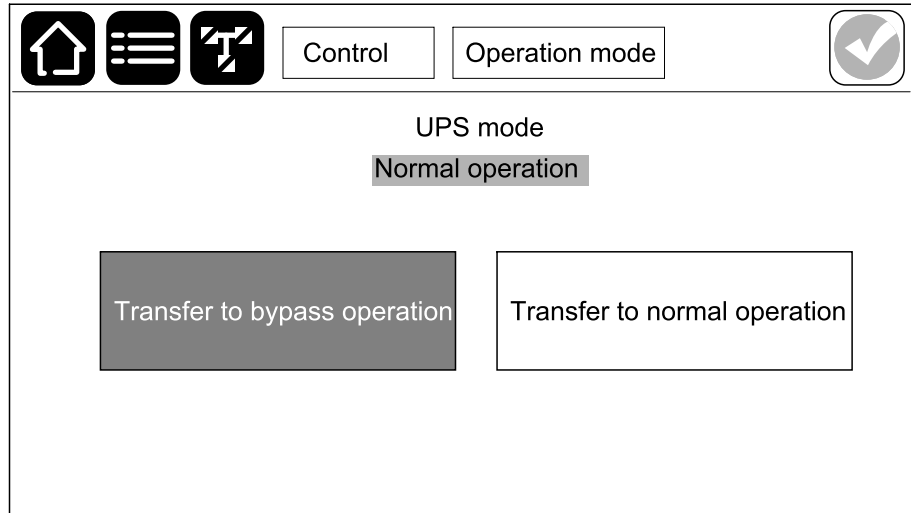

2. Tap **OK** on the confirmation screen.

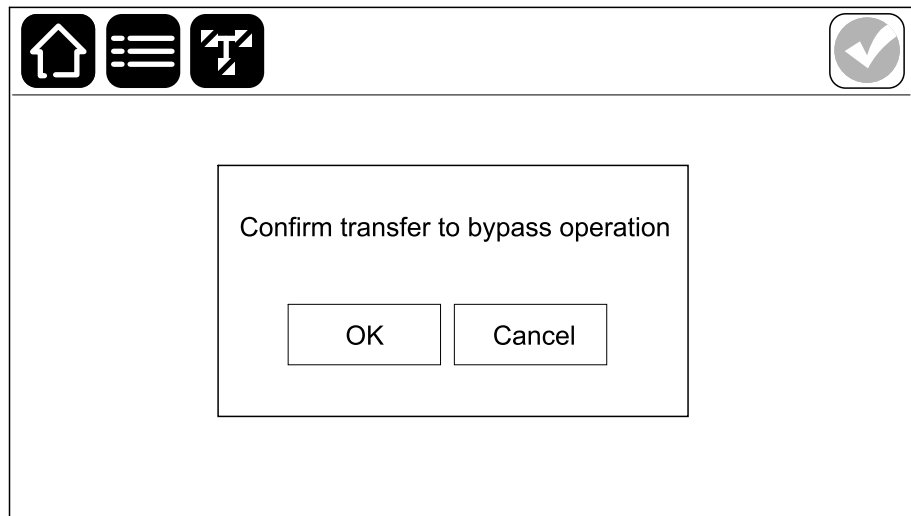

3. If bypass is out of tolerance, a pop-up warning will show on the display.

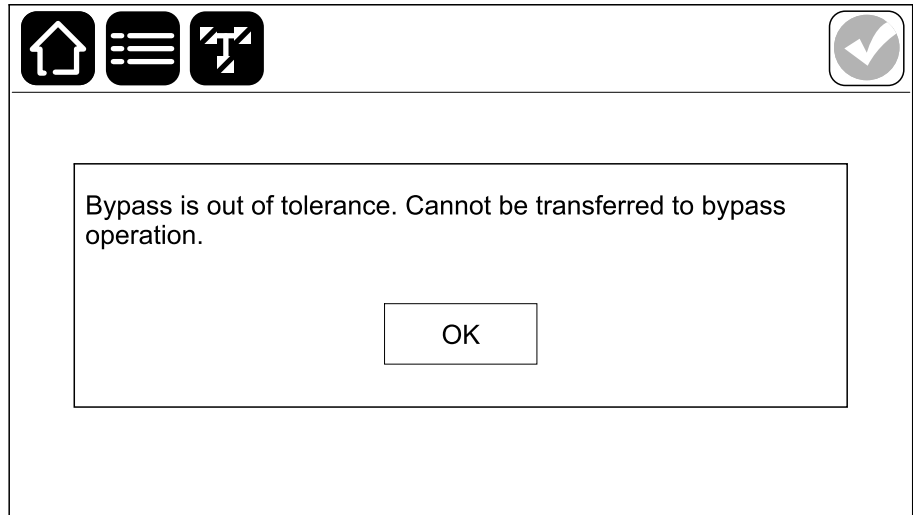

NOTE: It is not allowed to be transferred to bypass operation mode. If you still want to transfer to bypass operation mode with break, refer to Turn the Inverter OFF, page 46.

Transfer the UPS from Static Bypass Operation to Normal Operation

1. From the main menu, tap **Control > Operation mode > Transfer to normal operation**.
2. Tap **OK** on the confirmation screen.
3. If bypass is out of tolerance, a pop-up warning will show on the display.

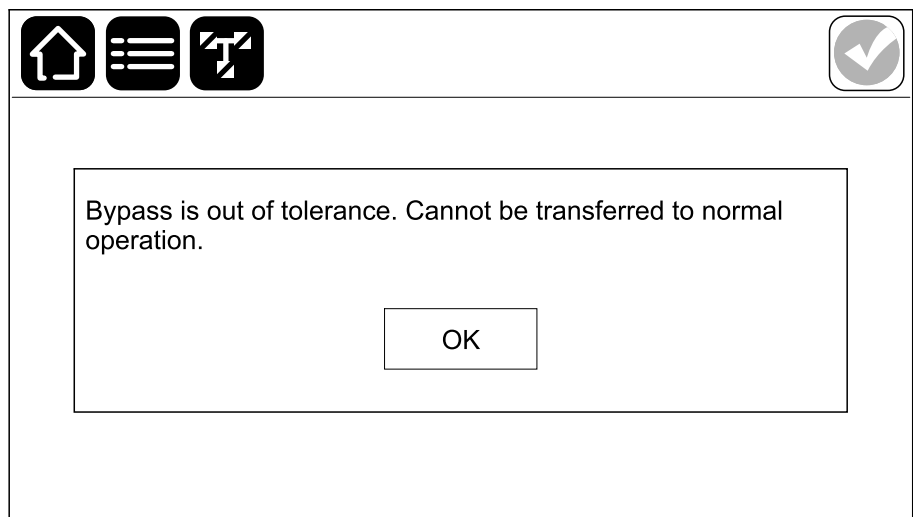

Turn the Inverter OFF

1. From the main menu, tap **Control > Inverter > Inverter off**.

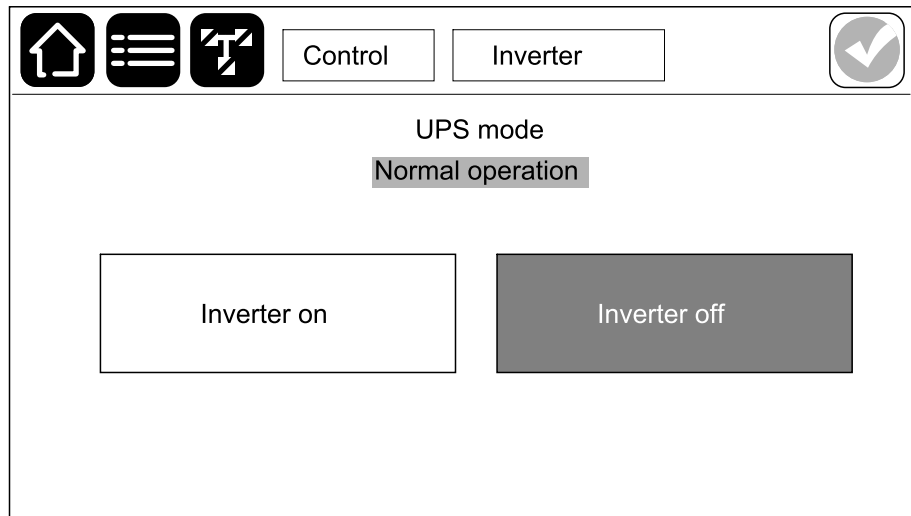

2. Tap **OK** on the confirmation screen.



3. If bypass is out of tolerance, a pop-up warning will show on the display. Click **OK** to transfer with break or click **No** to stay in inverter operation.

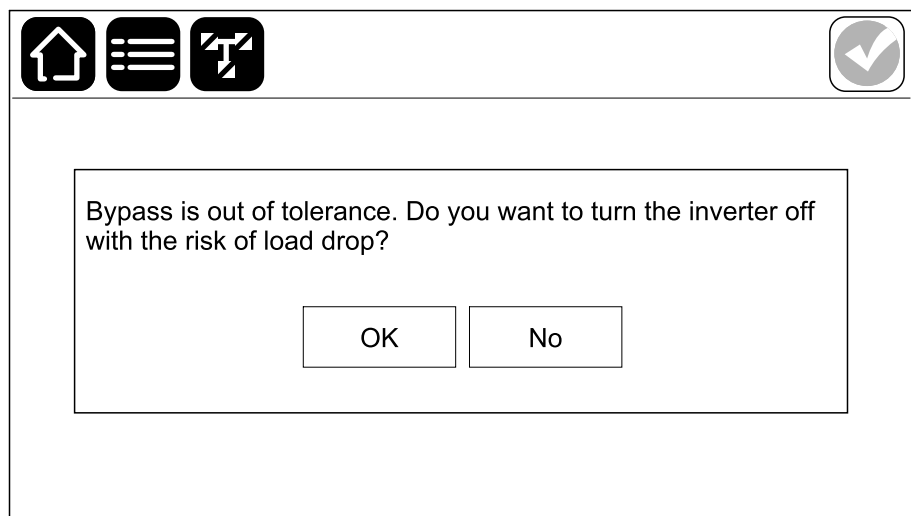

Turn the Inverter ON

NOTE: This function is only available if enabled by Service.

1. From the main menu, tap **Control > Inverter > Inverter on**.
2. Tap **OK** on the confirmation screen.

Set the Charger Mode

1. From the main menu, tap **Control > Charger mode**.

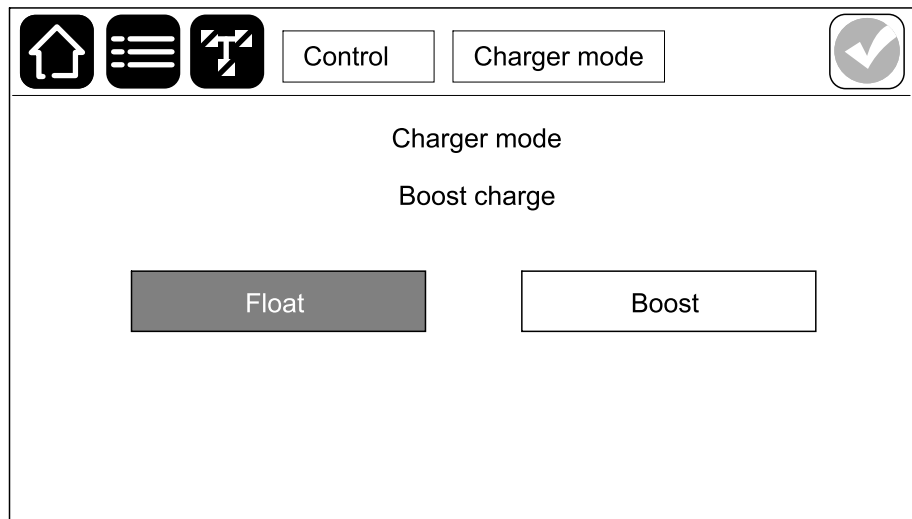

2. Tap **Float** or **Boost**.
3. Tap **OK** on the confirmation screen.

Start Up a Single UPS in Normal Operation

1. Check that all disconnect devices are in the OFF (open) position.
2. Close SSIB.

The UPS display turns on and the Home screen is shown. Wait approximately 20 seconds and the UPS starts up in static bypass operation.

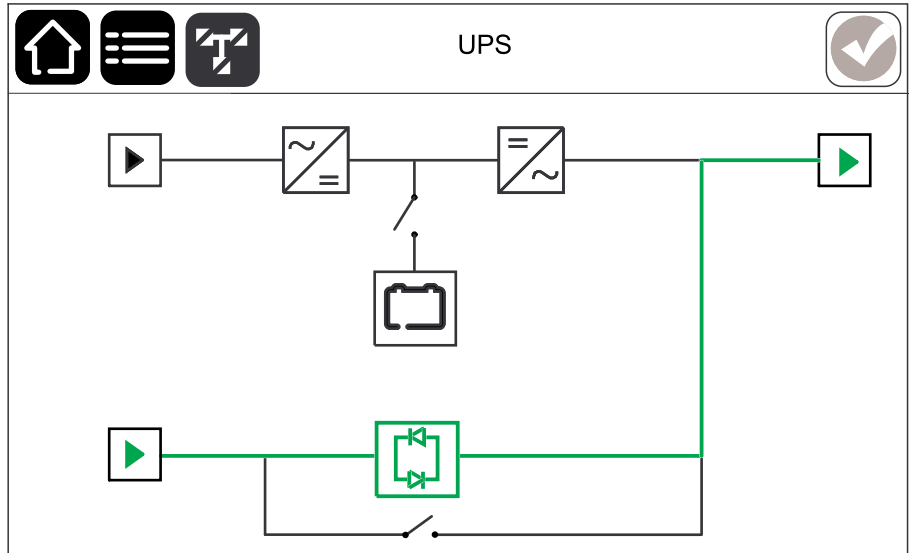

3. Close UOB.
4. Close UIB.

Wait approximately 10 seconds and the rectifier ramps up.

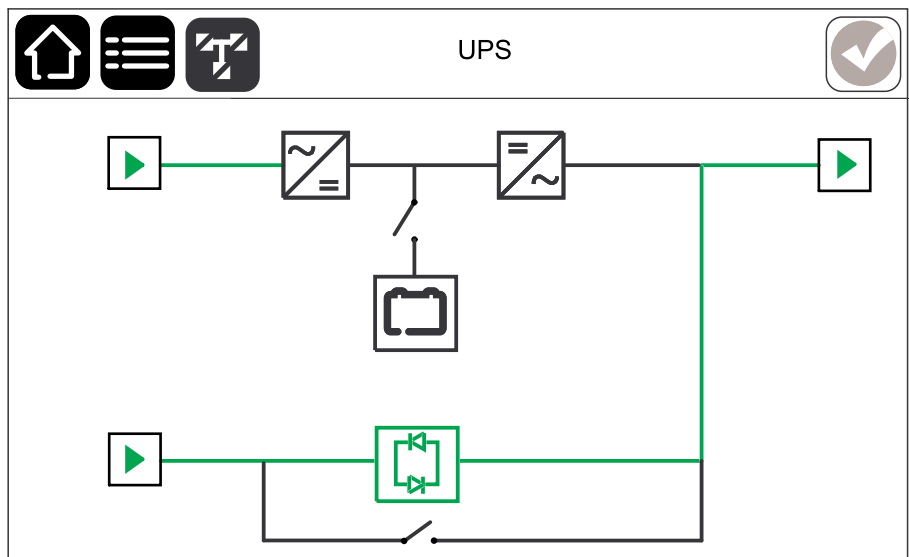

- Wait approximately 100 seconds and the UPS transfers to normal operation.

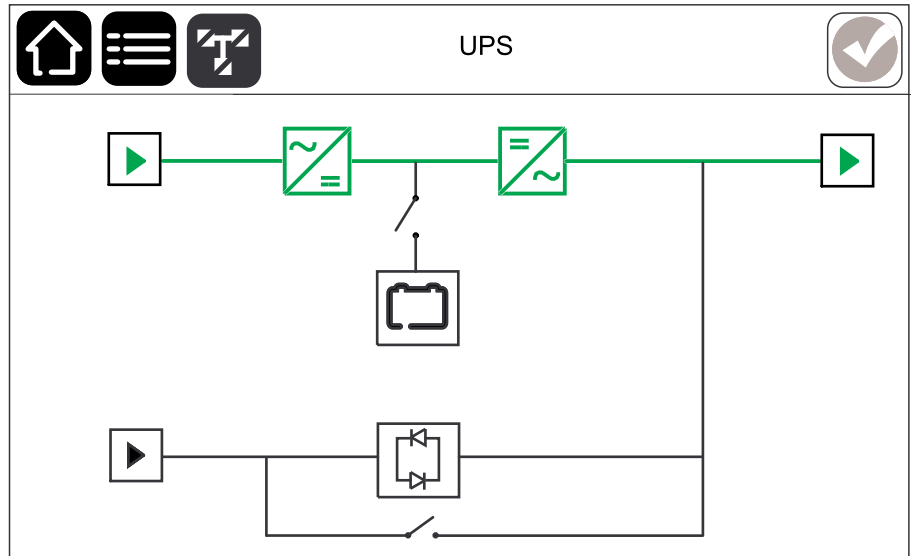

- Close BB.

Wait approximately 35 seconds and the mimic diagram on the display should be shown as below.

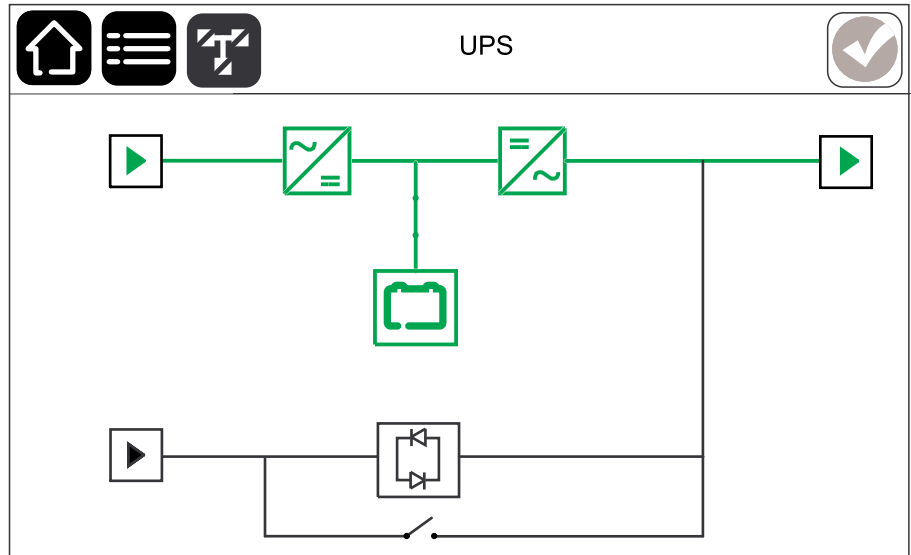

Shut Down a Single UPS

1. Open BB.

Wait approximately 10 seconds and the mimic diagram is shown on the display.

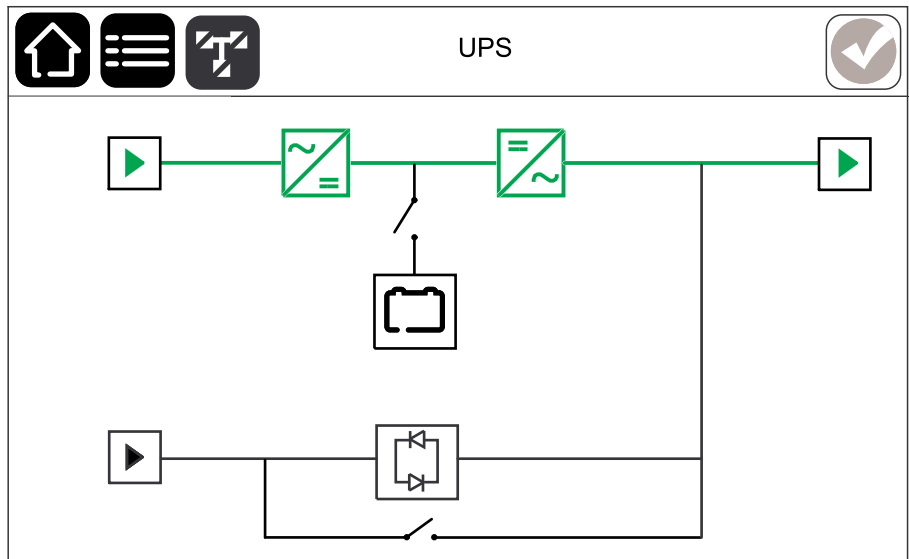

2. Open UIB.

Wait approximately 1 second and the UPS transfers to static bypass operation mode.

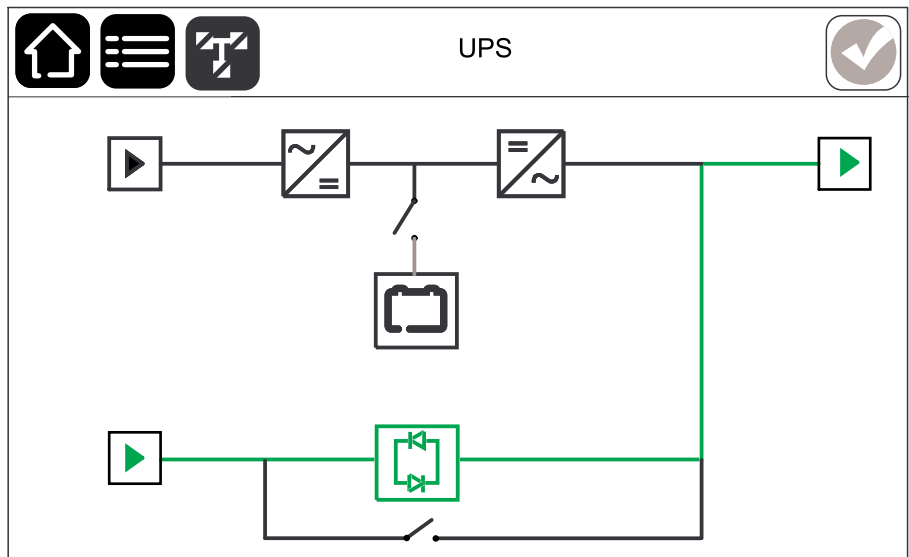

3. Open SSIB.

The UPS display turns off and the UPS shuts down.

4. Open UOB.

Transfer a Single UPS from Normal Operation to Maintenance Bypass Operation

- From the main menu, tap **Control > Operation mode > Transfer to bypass operation**.

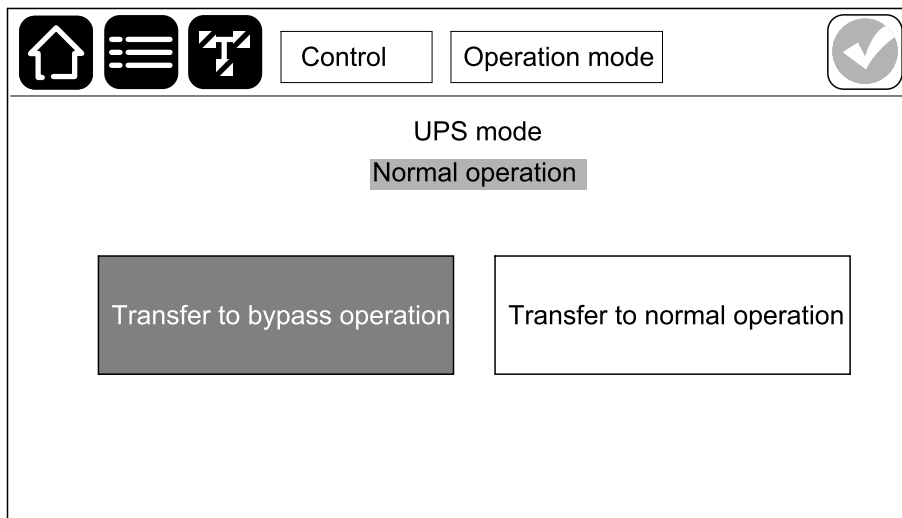

- Tap **OK** on the confirmation screen.

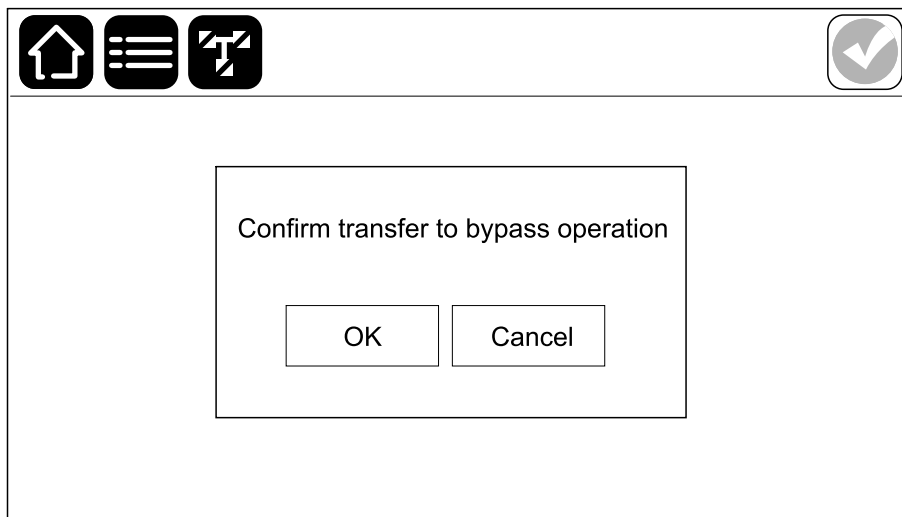

- Check that the UPS is in bypass operation mode from the mimic diagram.

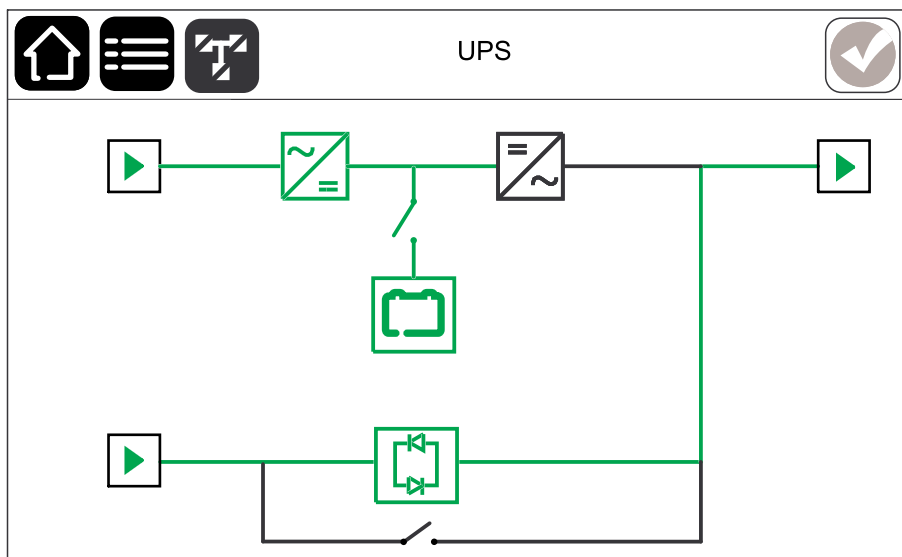

- Remove the cover from MBB.

5. Close MBB.
6. Open UOB.
7. Open all battery disconnect devices.
8. Open UIB.

9. Open SSIB.

Rear View of 10-20 kVA 3:3 UPS (Internal Batteries)

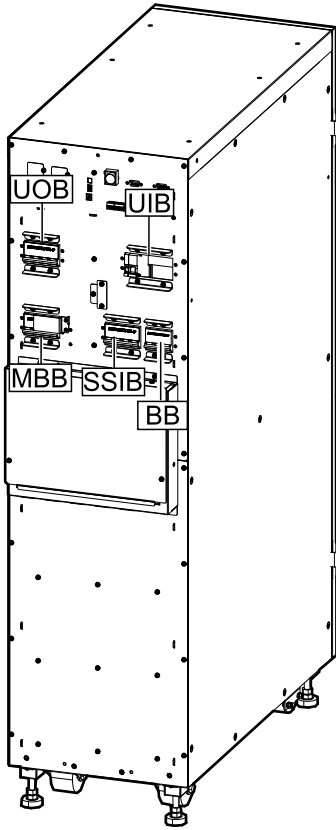

Rear View of 30-40 kVA 3:3 UPS (Internal Batteries)

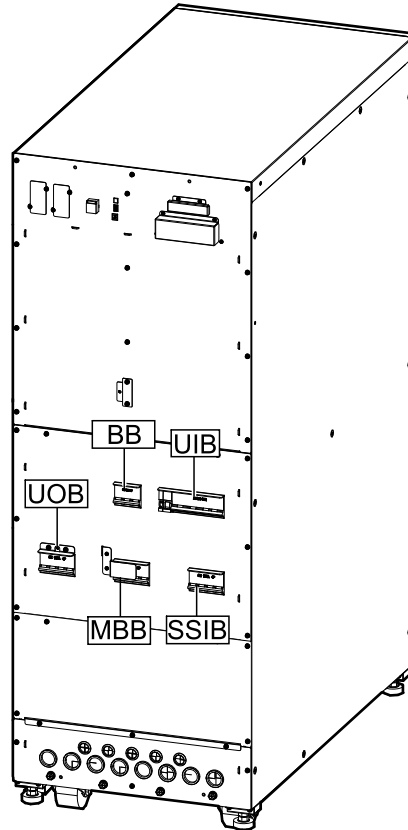

Rear View of 10-20 kVA 3:1 UPS (Internal Batteries)

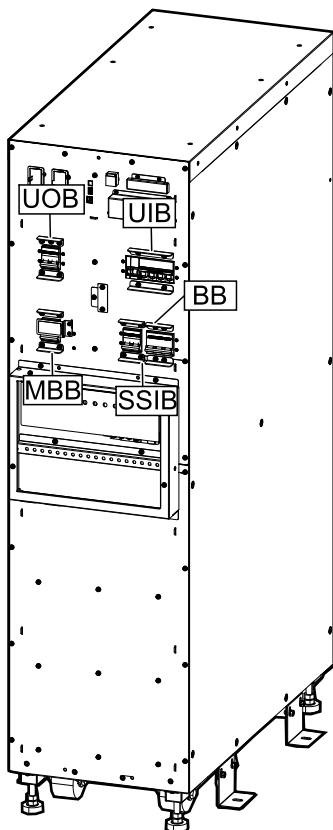

Rear View of 30 kVA 3:1 UPS (Internal Batteries)

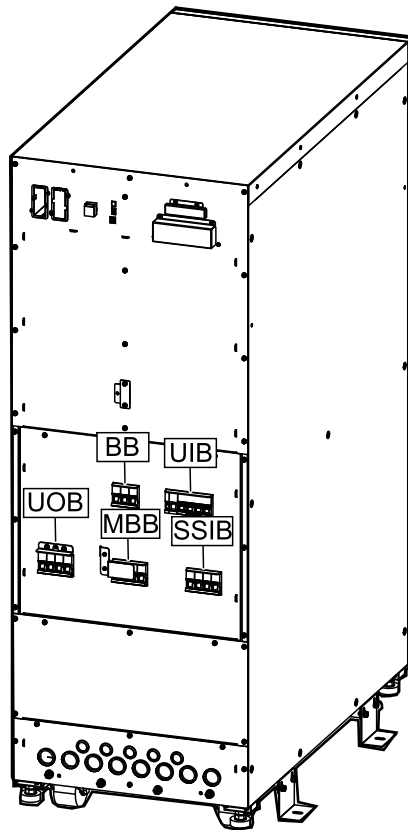

Rear View of 10-20 kVA 3:3 UPS (External Batteries)

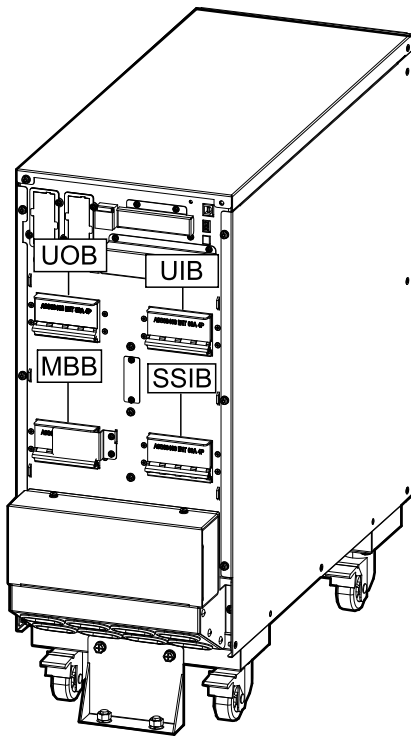

Rear View of 30-40 kVA 3:3 UPS (External Batteries)

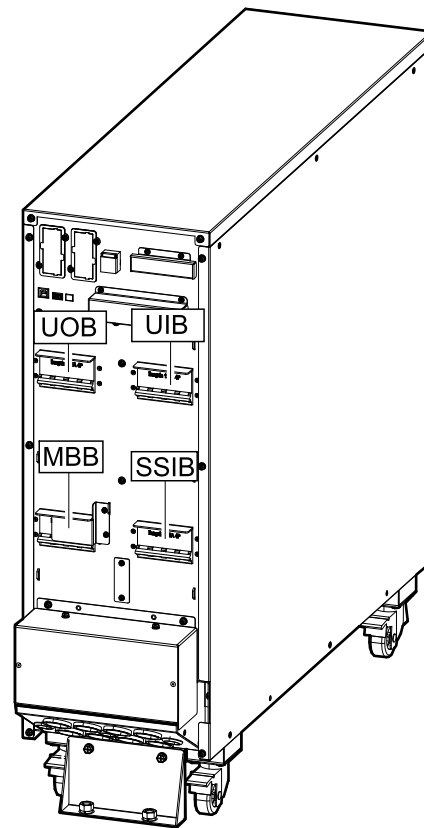

Rear View of 10-20 kVA 3:1 UPS (External Batteries)

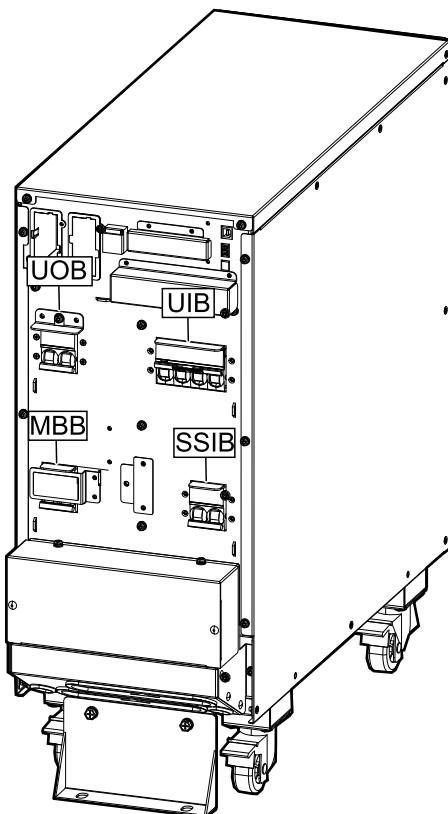

Rear View of 30 kVA 3:1 UPS (External Batteries)

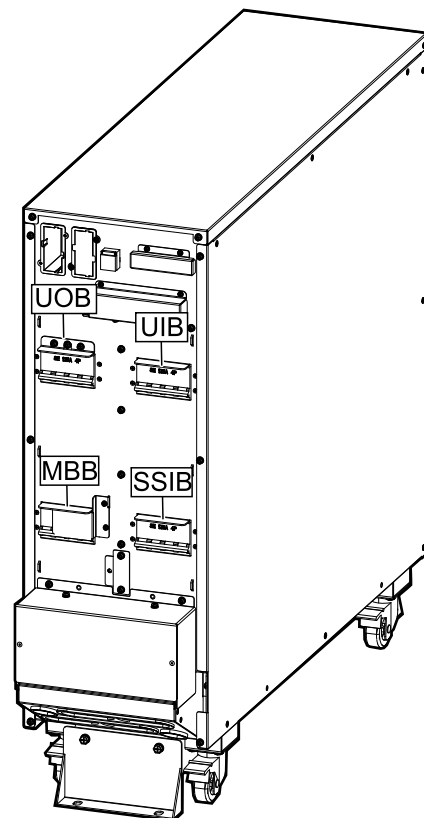

Transfer a Single UPS from Maintenance Bypass Operation to Normal Operation

NOTE: This procedure uses internal disconnect devices only.

1. Check that:
 - UIB, SSIB, and UOB for this UPS are in the OFF (open) position.
 - BB for this UPS is in the OFF (open) position.
 - MBB for this UPS is in the ON (closed) position.
 - the MBB cover for this UPS is removed.
2. Close SSIB for this UPS.
3. Close UOB for this UPS, and the UPS will operate in bypass operation.
4. Open MBB for this UPS.
5. Reinstall the cover on MBB for this UPS.
6. Close UIB for this UPS.
7. Close all battery disconnect devices for this UPS.
8. On this UPS, from the main menu, tap **Maintenance > Alarm clear**. Wait approximately 100 seconds and the UPS will transfer to normal operation.

Transfer a Parallel System from Normal Operation to Maintenance Bypass Operation

1. On the display of any one UPS in the parallel system, from the main menu, tap **Control > Operation mode > Transfer to bypass operation**.
2. Close Ext. MBB.
The load is now supplied via the Ext. MBB.
3. Open SIB.
4. Open all BBs on all UPSs.
5. Open MIBs and BIBs on all UPSs.
6. Open all Ext. UOBs on all UPS.
7. Open UIB, SSIB, UOB for each UPS.

Transfer a Parallel System from Maintenance Bypass Operation to Normal Operation

1. Check that:
 - UIB, SSIB, UOB, MBB for all UPSs are in the OFF (open) position.
 - Ext. UOB, MIB, BIB, BBs for all UPSs are in the OFF (open) position.
2. Close SSIB, UIB, UOB on all UPSs.
3. Close Ext. UOB on all UPSs.
4. Close SIB.
5. Close BIB on all UPSs. Wait approximately 20 seconds and the UPS starts up in static bypass operation.
6. Open Ext. MBB.

NOTE: If the parallel system has input contacts with MBB contact NO or MBB contact NC signal, on the display of any one UPS in the parallel system, from the main menu, tap **Maintenance > Alarm clear**.
7. Close MIB and BBs on all UPSs. Wait approximately 100 seconds and the system transfers to normal operation.

Isolate a Single UPS from the Parallel System

Use this procedure to shut down one UPS in a running parallel system.

NOTE: Before initiating this procedure, ensure that the remaining UPSs can supply the load.

NOTE: The following is a generic shutdown procedure. All the disconnect devices mentioned may not be present in your specific system.

1. On this UPS, select **Control > Inverter > Inverter off**. Tap **OK** on the confirmation screen.
2. Open UOB for this UPS.
3. Open SSIB for this UPS.
4. Open BB for this UPS.
5. Open UIB for this UPS.

- Open MIB (if present), BIB (if present), Ext. UOB (if present) for this UPS.

Rear View of 10-20 kVA 3:3 UPS (Internal Batteries)

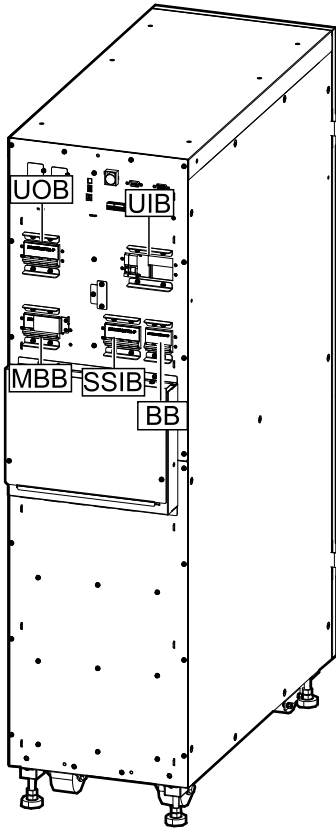

Rear View of 30-40 kVA 3:3 UPS (Internal Batteries)

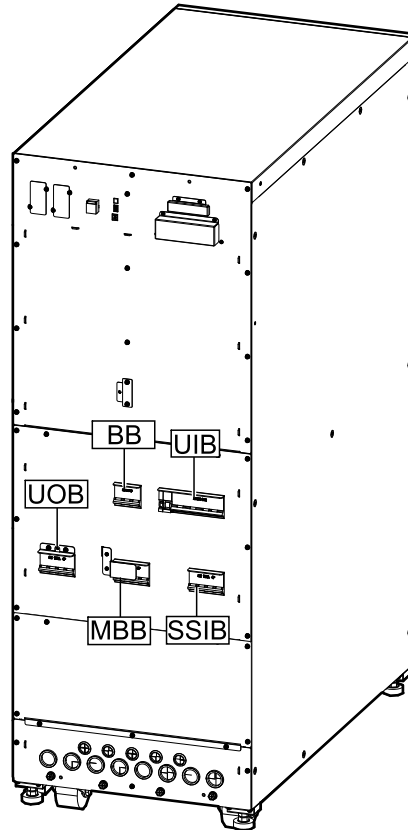

Rear View of 10-20 kVA 3:1 UPS (Internal Batteries)

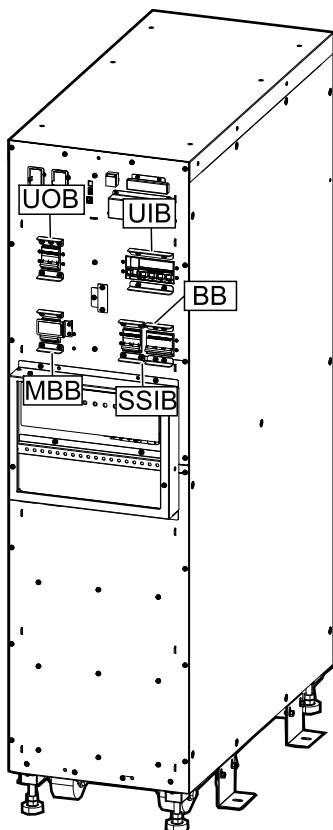

Rear View of 30 kVA 3:1 UPS (Internal Batteries)

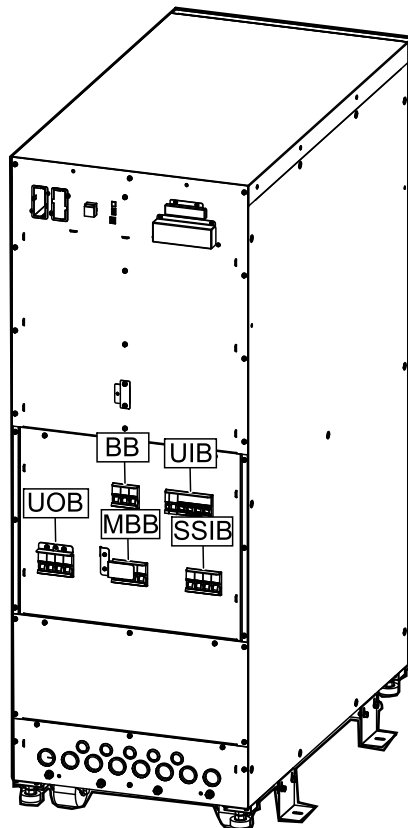

Rear View of 10-20 kVA 3:3 UPS (External Batteries)

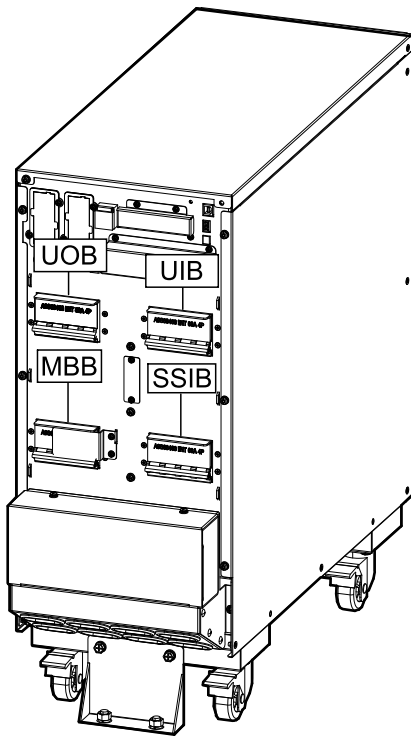

Rear View of 30-40 kVA 3:3 UPS (External Batteries)

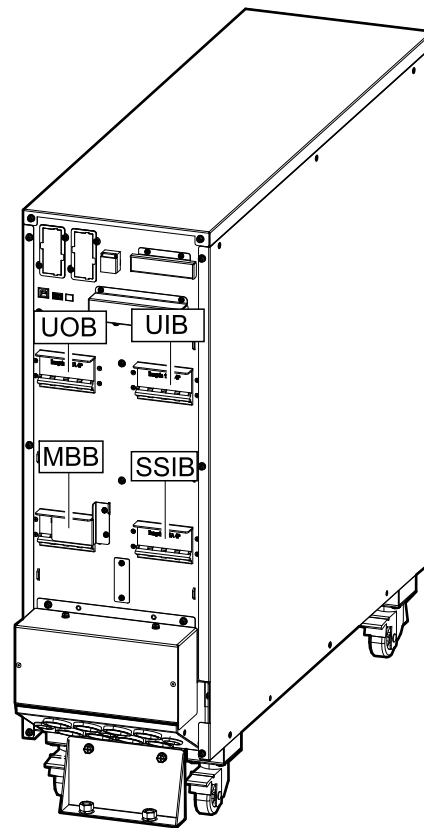

Rear View of 10-20 kVA 3:1 UPS (External Batteries)

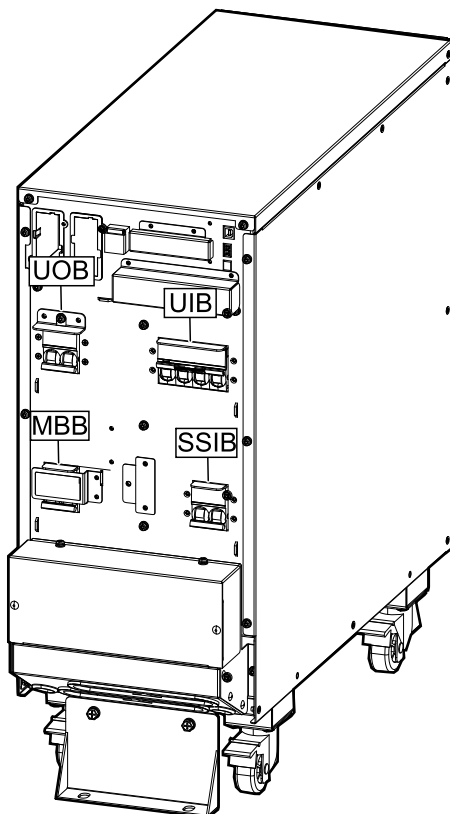

Rear View of 30 kVA 3:1 UPS (External Batteries)

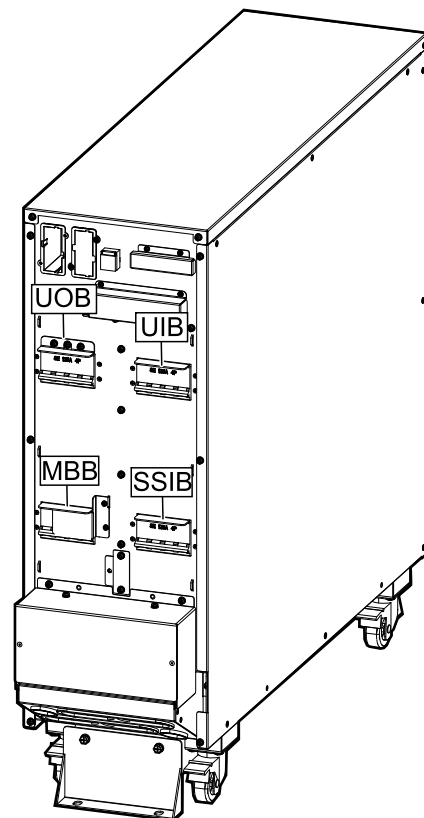

Start Up and Add a UPS to a Running Parallel System

Use this procedure to start up and add one UPS to a running parallel system.

NOTE: Before a UPS can be added to a parallel system, the parallel system must be configured by Schneider Electric.

1. On the new UPS, check that UIB, SSIB, and UOB are in the ON (closed) position.
2. Close Ext. UOB.
3. Close MIB and BIB for this UPS .
4. Close BB for this UPS.
5. Verify correct load sharing between the parallel UPS units.

View the Logs

1. From the main menu, tap **Logs**. The log shows the latest 2000 events with the newest events at the top of the list.
 - a. Tap the arrow buttons to go to the next or previous page.
 - b. Tap the double arrow buttons to go the first or last page.

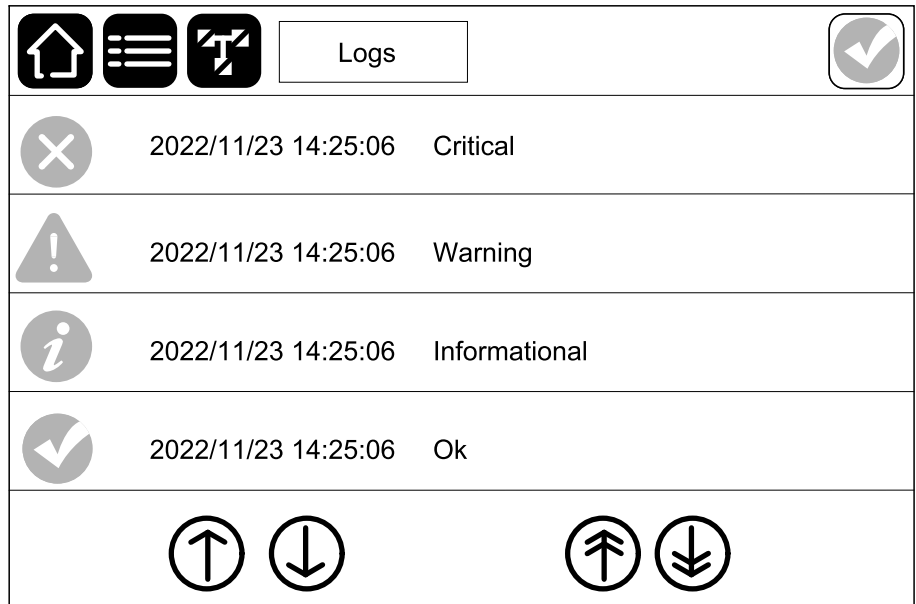

View the System Status Information

- From the main menu, tap **Status**.

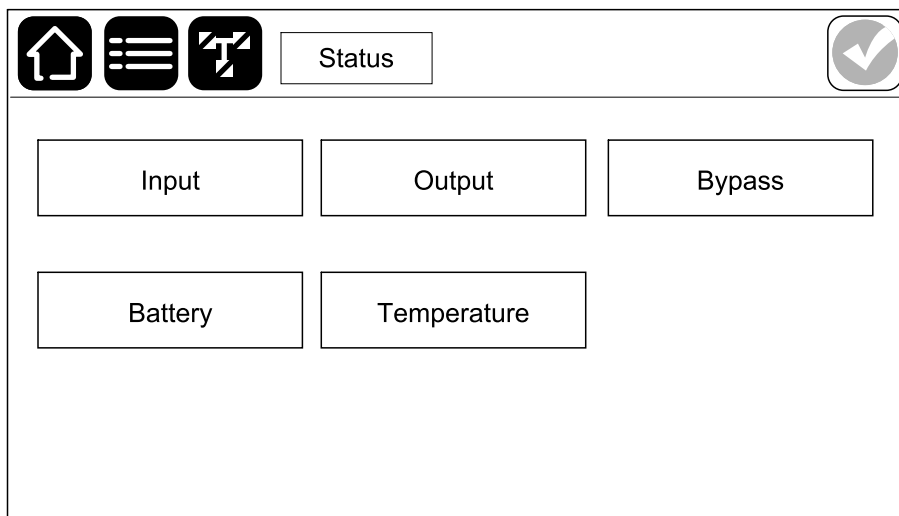

- Tap **Input** to see the status.

Input

Voltage ph-ph (phase-to-phase)	The present phase-to-phase input voltage.
Voltage ph-N (phase-to-neutral) ⁽⁸⁾	The present phase-to-neutral input voltage in volts (V).
Current	The present input current from the AC utility power source per phase in amperes (A).
Frequency	The present input frequency in hertz (Hz).
Power factor	The ratio of the active power to apparent power.

- Tap **Output** to see the status.

Output

Voltage ph-ph (phase-to-phase)	The phase-to-phase output voltage at the inverter in volts (V).
Voltage ph-N (phase-to-neutral) ⁽⁸⁾	The phase-to-neutral output voltage at the inverter in volts (V).
Current	The present output current for each phase in amperes (A).
Frequency	The present output frequency in hertz (Hz).
Power factor	The present output power factor for each phase. Power factor is the ratio of active power to apparent power.
Power	The present active power (or real power) output for each phase in kilowatts (kW). Active power is the portion of power flow that, averaged over a complete cycle of the AC waveform, results in net transfer of energy in one direction.
Load	The percentage of the UPS capacity presently used across all phases. The load percentage for the highest phase load is displayed.

- Tap **Bypass** to see the status.

⁽⁸⁾ Only applicable in systems with neutral connection.

Bypass

Voltage ph-ph (phase-to-phase)	The present phase-to-phase bypass voltage (V).
Voltage ph-N (phase-to-neutral) ⁽⁹⁾	The present phase-to-neutral bypass voltage (V).
Current	The present bypass current for each phase, in amperes (A).
Frequency	The present bypass frequency in hertz (Hz).
Power factor	The present bypass power factor for each phase. Power factor is the ratio of active power to apparent power.

d. Tap **Battery** to see the status.

Battery

Measurements	The present DC power being drawn from the battery, in kilowatts (kW).
	The present battery voltage (VDC).
	The present battery current in amperes (A). A positive current indicates that the battery is charging; a negative current indicates that the battery is discharging.
	Battery temperature from the connected temperature sensors in Celsius.
	The status of the battery (Disconnect or Connect).
Battery	The amount of time before the batteries reach the low-voltage shutdown level. Also shows charge level of the battery as a percentage of full charge capacity.
	The present battery charge (Ah).
Charger	The operation mode of the charger (Resting, Float charge, Boost charge, Discharge).

e. Tap **Temperature** to see the status.

Temperature

Ambient temperature	Ambient temperature in Celsius.
Battery temperature	Battery temperature in Celsius from the connected battery temperature sensors.

⁽⁹⁾ Only applicable in systems with neutral connection.

Maintenance

Recommended Personal Protective Equipment (PPE)

For all procedures where the outermost front door on the unit is opened, Schneider Electric recommends the following personal protective equipment (PPE) as a minimum:

- Non-flammable cotton clothing
- Eye protection (e.g. glasses or goggles)
- Safety shoes
- Any personal protective equipment required or recommended by local or national regulation

▲ CAUTION

RISK OF PERSONAL INJURY

Always perform a risk assessment before operating or maintaining this equipment. Use appropriate personal protection equipment.

Failure to follow these instructions can result in injury or equipment damage.

Connect the Temperature Sensor Kit (Option)

NOTE: Use the optional temperature sensor kit (E3SOPT003) for this procedure.

1. Connect the temperature sensor kit to the terminal J3-5/6 (for ambient temperature measurement) or J4-1/2 (for battery temperature measurement) in the dry contacts. See the UPS installation manual for details.
2. To see the temperature measurements, tap **Status > Temperature**.

Replace the Air Filter on UPS for Internal Batteries

1. Open the front door.
2. Loosen the screws and remove the metal brackets and the manual compartment.

Rear View of the Front Door for 10-20 kVA UPS

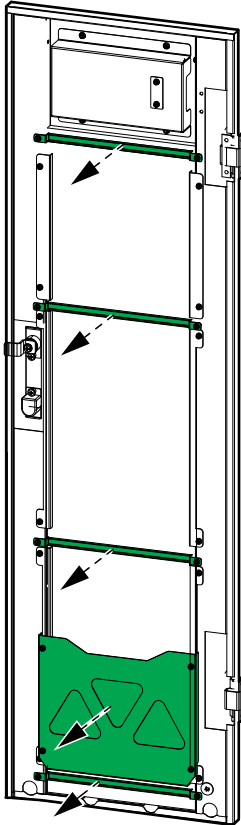

Rear View of the Front Door for 30-40 kVA UPS

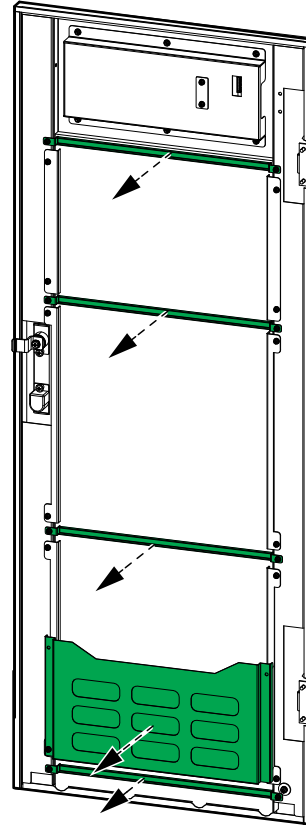

3. Replace the air filter.

Rear View of the Front Door for 10-20 kVA UPS

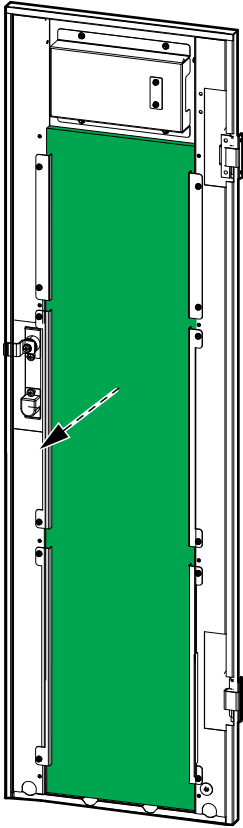

Rear View of the Front Door for 30-40 kVA UPS

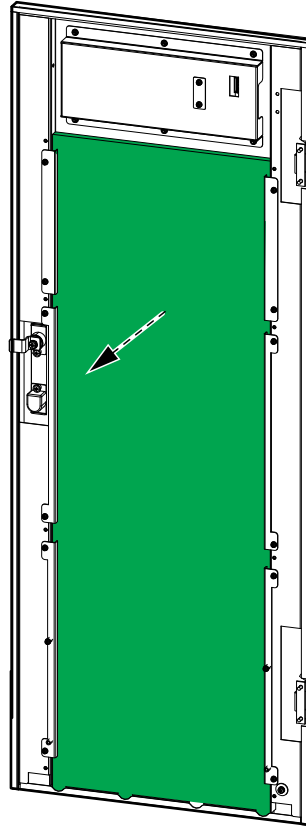

4. Reinstall the metal brackets and the manual compartment.

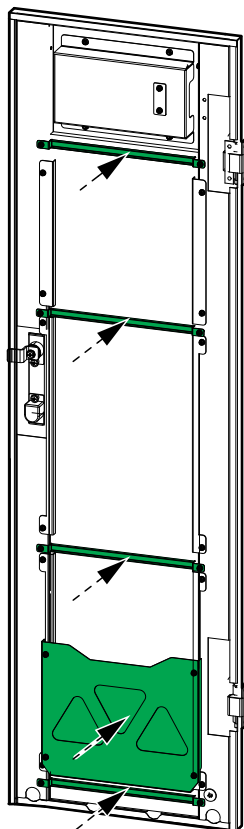
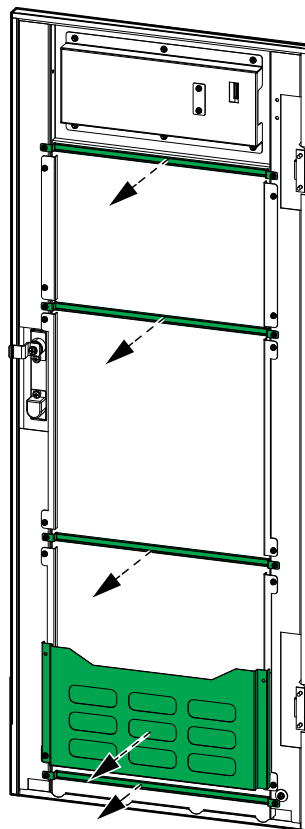
Rear View of the Front Door for 10-20 kVA UPS**Rear View of the Front Door for 30-40 kVA UPS**

5. Close the front door.
6. Restart the air filter counter, see [Configure the Air Filter Reminder](#), page 42.

Replace the Air Filter on UPS for External Batteries

1. Remove the front panel from the UPS.

NOTE: Be careful not to disconnect the cables on the rear side of the front panel.

10-20 kVA UPS

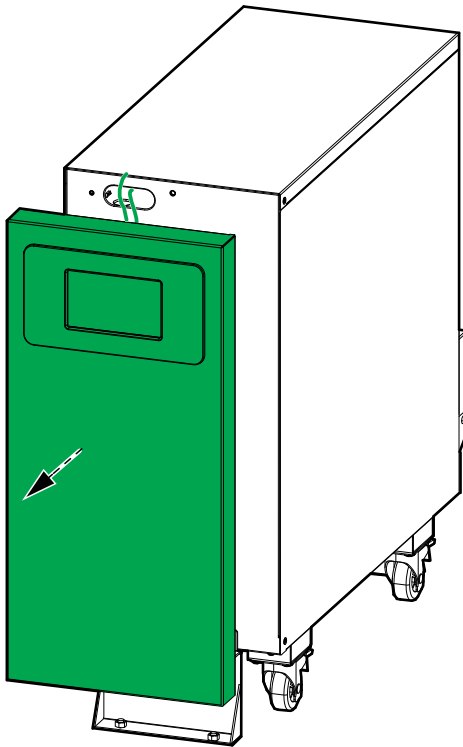

30-40 kVA UPS

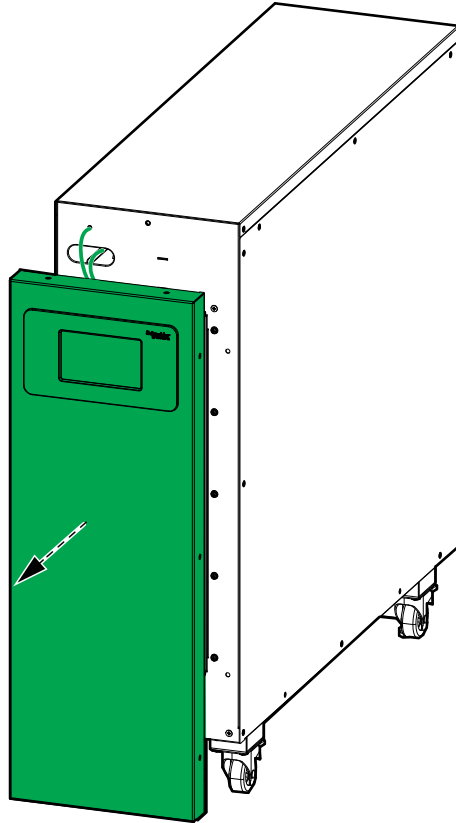

2. Loosen the screws and remove the three support brackets.

Rear View of the Front Door for 10-20 kVA UPS

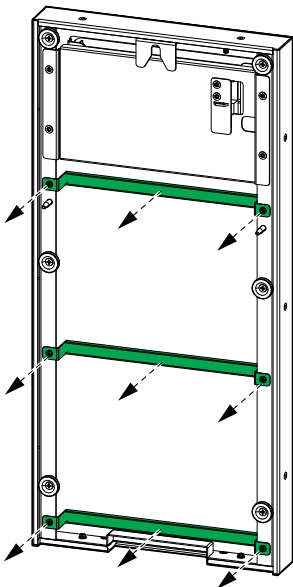

Rear View of the Front Door for 30-40 kVA UPS

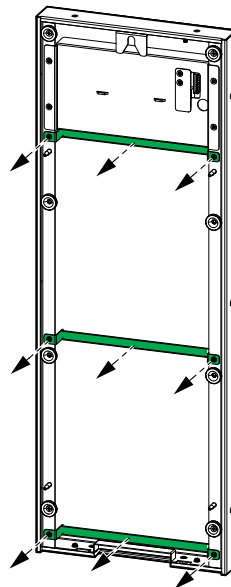

3. Remove the air filter from the front panel.

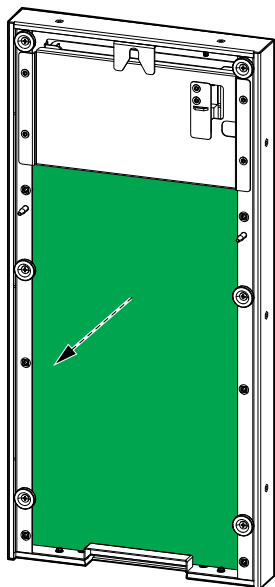
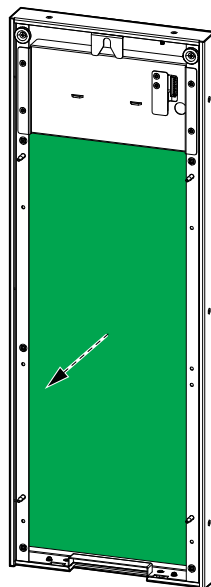
Rear View of the Front Door for 10-20 kVA UPS**Rear View of the Front Door for 30-40 kVA UPS**

4. Install the new air filter in the front panel.
5. Reinstall the support brackets and fasten the screws.
6. Reinstall the front panel.
7. Restart the air filter counter, see [Configure the Air Filter Reminder](#), page 42.

Determine if you need a Replacement Part

To determine if you need a replacement part, contact Schneider Electric and follow the procedure below so that the representative can assist you promptly:

1. In the event of an alarm condition, scroll through the alarm lists, record the information, and provide it to the representative.
2. Write down the serial number of the unit so that you will have it easily accessible when you contact Schneider Electric.
3. If possible, call Schneider Electric from a telephone that is within reach of the display so that you can gather and report additional information to the representative.
4. Be prepared to provide a detailed description of the problem. A representative will help you solve the problem over the telephone.
5. If the unit is within the warranty period and has been started up by Schneider Electric, repairs or replacements will be performed free of charge. If it is not within the warranty period, there will be a charge.
6. If the unit is covered by a Schneider Electric service contract, have the contract available to provide information to the representative.

Replace or Install a Modular Battery String

⚠️⚠️ DANGER

HAZARD OF ELECTRIC SHOCK, EXPLOSION, OR ARC FLASH

Batteries can present a risk of electric shock and high short-circuit current. The following precautions must be observed when working on batteries:

- Servicing of batteries must only be performed or supervised by qualified personnel knowledgeable of batteries and the required precautions. Keep unqualified personnel away from batteries.
- Do not dispose of batteries in a fire as they can explode.
- Do not open, alter, or mutilate batteries. Released electrolyte is harmful to the skin and eyes. It may be toxic.
- Remove watches, rings, or other metal objects.
- Use tools with insulated handles.
- Wear protective glasses, gloves and boots.
- Do not lay tools or metal parts on top of batteries.
- Set the battery disconnect device BB to the open (OFF) position before starting this procedure.

Failure to follow these instructions will result in death or serious injury.

⚠️ WARNING

RISK OF EQUIPMENT DAMAGE

- When replacing or installing battery modules, always use with the same battery module type (same commercial reference) in the entire UPS system.
- Always replace or install an entire battery string (four battery modules).
- Wait until the system is ready to be powered up before installing battery modules in the system. The time duration from battery module installation until the UPS system is powered up must not exceed 72 hours or 3 days.
- If the UPS system remains de-energized for a long period, we recommend that you energize the UPS system for a period of 24 hours at least once every month. This charges the installed battery modules, thus avoiding irreversible damage from deep discharging.
- Store the battery modules at an ambient temperature of -15 to 40 °C.
- Store the battery modules in their original protective packaging.
- Battery modules stored at -15 to 25 °C must be recharged every six months to avoid damages from deep discharging. Battery modules stored at over 25 °C must be recharged at shorter intervals.

Failure to follow these instructions can result in death, serious injury, or equipment damage.

NOTICE

RISK OF LOAD DROP

Battery backup is not available from a cabinet when the battery disconnect device BB on the cabinet is in the open (OFF) position.

Failure to follow these instructions can result in equipment damage.

1. Set the battery disconnect device BB to the open (OFF) position on the UPS and/or the modular battery cabinet where battery modules must be replaced or installed.
2. Remove the battery cover from the UPS and/or the modular battery cabinet.

3. Remove a battery module:
 - a. Disconnect the battery terminals from the front of the battery module.

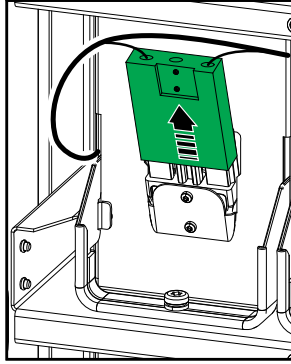

- b. Remove the screw from the battery module handle and turn the handle upwards.
 - c. Pull the battery module carefully out of the slot. Always remove the complete battery string (four battery modules).
 4. Install a battery module:
 - a. Push the battery module into the slot. Fill the shelves from the bottom and upwards. Always install a complete battery string (four battery modules).
 - b. Turn down the handle on the battery module and fasten the handle to the shelf with the provided screw.
 - c. Connect the battery terminals to the front of the battery module.

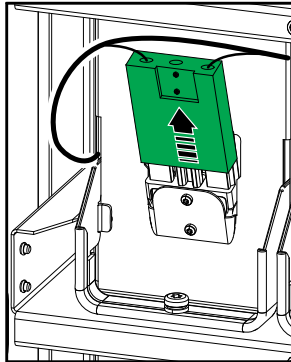

5. Reinstall the battery cover on the UPS and/or the modular battery cabinet.
6. Set the battery disconnect device BB to the closed (ON) position on the UPS and/or the modular battery cabinet.

Find the Serial Numbers

1. From the main menu, tap **About**.
2. Note down the serial number of the UPS cabinet and have it ready for customer support.

NOTE: If the display is not available, look at the top of the UPS and find the UPS serial number on the name plate label under SERIAL:

Example of Name Plate Label for UPS

Schneider ELECTRIC		Easy UPS 3S Pro	
Easy UPS 3S Pro 3:3		40kVA/40kW	
Input:	3W+N+PE	380/400/415V	
Icc=10kA	81/77/74A	50/60Hz	
Bypass:	3W+N+PE	380/400/415V	
Icc=10kA	62/59/57A	50/60Hz	
Output:	3W+N+PE	380/400/415V	
Icc=10kA	61/58/56A	50/60Hz	
Operating Temperature: 0 °C~40°C			
Protective Class I			
Model:	 E3SP40KH		
S/N:	 9J2447T10002		
Manufactured through ISO9001 process			
     			
www.schneider-electric.com/contact Schneider Electric, 35 Rue Joseph Monier 92506 Rueil Malmaison, France			
			Made in China

Find More Support with Digital Experience

Find more digital support on your product here.

1. From the main menu, tap **Digital Experience**.

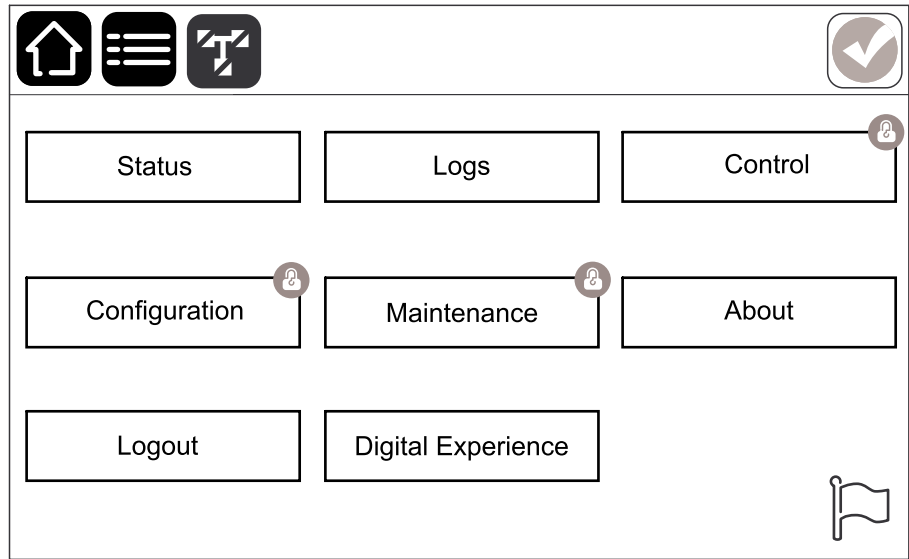

2. **For digital support:** Scan the left code to download the mySchneider application on your mobile device.
For digital product documentation: Scan the right code to get the latest product documentation.

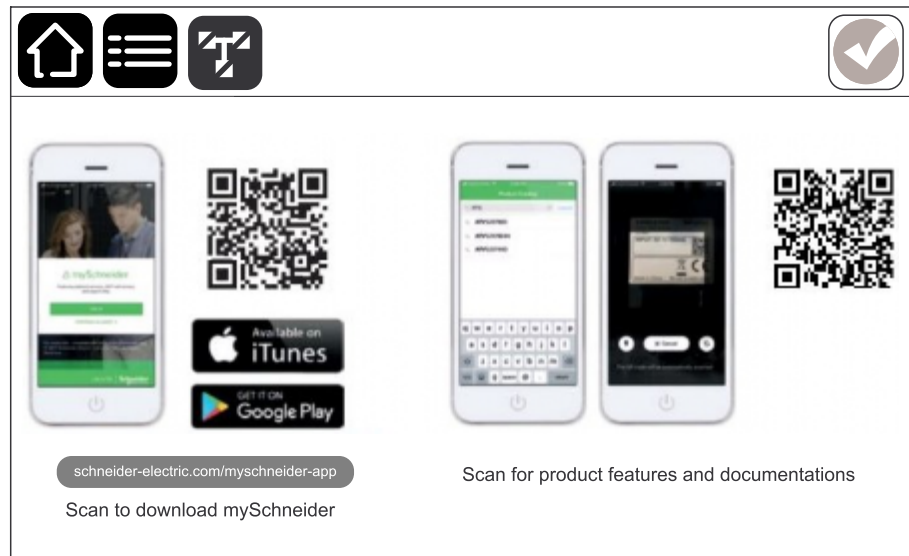

Return Parts to Schneider Electric

To return an inoperable part to Schneider Electric, contact Schneider Electric customer support.

Pack the part in the original shipping materials, and return it by insured, prepaid carrier. The customer support representative will provide the destination address. If you no longer have the original shipping materials, ask the representative about obtaining a new set.

- Pack the part properly to avoid damage in transit. Never use styrofoam beads or other loose packaging materials when shipping a part. The part may settle in transit and become damaged.
- Enclose a letter in the package with your name, address, a copy of the sales receipt, description of the problem, a phone number, and a confirmation for payment (if necessary).

NOTE: Damages sustained in transit are not covered under warranty.

Troubleshooting

Alarm Messages

Display text	Description	Corrective action
Air filter check required	The air filter service life has expired and requires a check.	Replace the air filter.
Battery boost charging	The batteries are charged with the configured boost charge voltage.	
Battery connected	The batteries are connected.	
Battery discharging	Batteries are discharging.	
Battery disconnected	The batteries are not connected.	Connect the batteries.
Battery end of discharge	The battery capacity is below the minimum acceptable value.	Recharge the batteries.
Battery float charging	The batteries are charged with the configured float charge voltage.	
Battery log reset	Reset the battery log.	
Batt maint incomplete	The battery maintenance test was not passed.	
Battery maintenance	Battery maintenance test has started.	
Battery maintenance OK	The battery maintenance test has been successfully completed.	
Battery overvoltage	The battery voltage exceeds the limit.	Check the battery voltage.
Battery temperature high	The battery temperature is too high.	Check the battery temperature.
Battery test	Battery test has started.	
Battery test incomplete	The battery test was not passed.	
Battery test OK	The battery test has been successfully completed.	
Battery voltage low	Low voltage on battery.	Check the battery.
Battery wiring incorrect	The battery wiring is incorrect.	Check the battery wiring. Contact Schneider Electric.
Battery/charger inoperable	The battery or charger is inoperable.	Check the battery. Check the charger. Contact Schneider Electric.
Bypass frequency exceeds limits	The bypass frequency exceeds the limit.	Check the status of the bypass source. Contact Schneider Electric.
Bypass out of tolerance	The bypass voltage is out of tolerance.	Check the status of the bypass source. Contact Schneider Electric.
Bypass overload	The load is drawing more power than the bypass source can supply.	Reduce the load. Contact Schneider Electric.
Bypass overload timeout	The UPS can no longer support a Bypass overload situation.	Reduce the load. Contact Schneider Electric.
Bypass sequence incorrect	The phase rotation on bypass is incorrect.	Check the status of the bypass source. Contact Schneider Electric.

Display text	Description	Corrective action
Bypass unavailable	The bypass source is not available.	Check the status of the bypass source. Contact Schneider Electric.
Alarm cleared	Clear the alarm.	
Log cleared	Clear the log.	
DC bus low voltage	Low voltage on the DC bus.	
DC bus overvoltage	Overvoltage on the DC bus.	
Dry input contact turns off charger	The dry input contact turns off the charger.	
EPO	An EPO (emergency power off) device is activated.	Deactivate the EPO (emergency power off) device.
Fan inoperable	The UPS has one or more inoperable fans.	Check the fans. Contact Schneider Electric.
Firmware version incompatible	The firmware version of the inverter is detected as incompatible with the firmware version of the rectifier.	Check if the firmware version for the inverter and the rectifier is the latest. Perform a firmware update on the inverter or the rectifier.
Frequency converter mode	The UPS is in frequency converter mode.	
Generator input	Generator is supplying the UPS.	
Inconsistent number of parallel	The configured number of parallel units does not match the actual number of units in the parallel system.	Check and set the number of parallel units.
Inconsistent parallel settings	The parallel settings are set incorrectly.	Check for inconsistent parallel settings in Configure > Rating and Configure > Output . Set them correctly. Contact Schneider Electric.
Inlet temperature high	Air inlet temperature is too high.	Check the status of the air inlet. Reduce the room temperature.
Inlet temperature sensor inoperable	No inlet temperature sensor is present.	Check the status of the inlet temperature sensor.
Input current unbalanced	Input current is unbalanced.	Check the status of the input source. Contact Schneider Electric.
Input neutral unavailable	Input neutral is not available.	Check the status of the input neutral. Contact Schneider Electric.
Input overcurrent timeout	The UPS can no longer support an Input overcurrent situation.	Check the status of the input source. Contact Schneider Electric.
Inverter high temperature	Inverter temperature is too high.	Check the status of the inverter. Contact Schneider Electric.
Inverter IGBT inoperable	The inverter IGBT is inoperable.	Check the status of the inverter IGBT. Contact Schneider Electric.
Inverter inoperable	The inverter is inoperable.	Check the status of the inverter. Contact Schneider Electric.
Inverter shutdown	The inverter is shutting down.	
Inverter data CAN incorrect	Inverter data CAN is incorrect.	
Inverter firmware incompatible	The inverter firmware is incompatible with the UPS.	
Inverter firmware upgrade	The inverter firmware has been upgraded.	

Display text	Description	Corrective action
Inverter IO CAN incorrect	Inverter IO CAN is incorrect.	
Inverter overload	The inverter is overloaded.	Check the status of the inverter. Contact Schneider Electric.
Inverter overload timeout	The UPS can no longer support an Inverter overload situation.	Check the status of the inverter. Contact Schneider Electric.
Inverter protection	The UPS has turned on the inverter protection.	Check the inverter voltage or current.
Load on bypass	The UPS is in static bypass operation and the load is supplied by the bypass source.	
Load disconnected	The load has been disconnected or the unit output disconnect device UOB is open.	Check the load. Close the unit output disconnect device UOB.
Load on inverter	The UPS is in inverter operation mode and the load is supplied by the UPS.	
Low battery shutdown	The UPS is shutting down due to battery end of discharge	Recharge the batteries and restart the UPS. If autostart mode is configured, the UPS will start automatically restart when the mains return.
Main power supply not available	The main power supply is not available.	Check the availability of the main power supply.
Manual boost charge	The UPS is in the manual boost charge mode.	
Manually exit bypass	The UPS exits the bypass operation mode manually.	
Manual float charge	The UPS is in the manual float charge mode.	
Manual transfer to inverter	Manual transfer to inverter operation.	
Manual transfer to bypass	Manual transfer to bypass operation.	
Manual shutdown	Manual shutdown.	
MBB closed latch	The maintenance bypass disconnect device MBB is closed, supplying the load with unprotected power from the bypass source.	
MBB open	The maintenance bypass disconnect device is open.	
Module ID duplicate	The module ID has a duplicate. The module ID must be unique.	Check the ID of the modules.
Nominal power out of tolerance	The nominal power does not match the UPS hardware.	Check the status of the input source. Contact Schneider Electric.
Outlet temperature high	Air outlet temperature is too high.	Check the status of the air outlet. Contact Schneider Electric.
Outlet temperature sensor inoperable	No outlet temperature sensor present or the outlet temperature sensor is inoperable.	Check the status of the outlet temperature sensor.
Output relay disconnected	An output relay is disconnected.	Check the status of the output relays. Contact Schneider Electric.

Display text	Description	Corrective action
Output relay short-circuit	An out put relay has short-circuited.	Check the status of the relays. Contact Schneider Electric.
Output short circuit	A short circuit is present on the output.	Check the status of the output. Contact Schneider Electric.
Output voltage detection unsuccessful	The output voltage could not be detected.	Check the output voltage.
Parallel cabling incorrect	The parallel cabling is incorrect.	Check the status of the parallel cables. Contact Schneider Electric.
Power sharing incorrect	The power sharing between the UPS units is incorrect.	Please check the load sharing on the UPS units. Redistribute the load between UPS units. Contact Schneider Electric.
Prohibit transferring to inverter	Transferring to inverter operation is prohibited.	
PWM synchronization unavailable	The PWM synchronization is unavailable.	Check the status of the PWM sync. Contact Schneider Electric.
Rectifier firmware upgraded	The rectifier firmware has been upgraded.	
Rectifier soft start incomplete	The rectifier soft start is incomplete.	Check the status of the rectifier. Contact Schneider Electric.
Rectifier high temperature	The rectifier temperature is too high.	Check the status of the rectifier. Contact Schneider Electric.
Rectifier inoperable	The rectifier is inoperable.	Check the status of the rectifier. Contact Schneider Electric.
Rectifier overload	The rectifier is overloaded.	Check if the rectifier is overloaded. Contact Schneider Electric.
Room temperature high	The room temperature is high.	Reduce the room temperature.
Save settings	Settings have been changed.	
SPI communication inoperable	SPI communication is lost between the rectifier and the inverter.	Check the SPI communication between the rectifier and the inverter.
Stop test	Stop the test.	
Surge protection abnormal	The SPD (surge protection device) is abnormal.	Contact Schneider Electric.
Synchronization pulse unavailable	Sync pulse is unavailable. The UPS is not able to synchronize.	Check the sync pulse. Contact Schneider Electric.
System overload	The load is drawing more power than the UPS system can supply.	Reduce the load. Contact Schneider Electric.
System setting incorrect	The system settings are incorrect.	Check the system settings. Contact Schneider Electric.
Technical check recommended	A technical check is recommended.	Contact Schneider Electric.
The battery self-test conditions are not met.	The battery self-test conditions are not met.	
Transfer to bypass not allowed	Transferring to bypass is not allowed.	
Transfers exceed limit	There have been too many transfers between operation modes in a given time period.	Contact Schneider Electric.

Display text	Description	Corrective action
Utility voltage exceeds limit	The detected transient input voltage input has exceeded the specified safety limit.	Adjust the main power supply voltage to the allowable range.
Warranty expired	Warranty is expired.	Contact Schneider Electric.

Export UPS Event Logs to a USB Device

Pre-condition:

1. Insert a USB flash drive (preferably less than 16 GB) in the computer, find the USB flash drive in **This PC** window, right-click and select **Format**, configure the file system as FAT32, 4096 bytes of allocation unit size, check **Quick Format > Start**.

NOTE: It is recommended to use a USB 2.0 flash drive, because USB 3.0 may not support the FAT32 format.

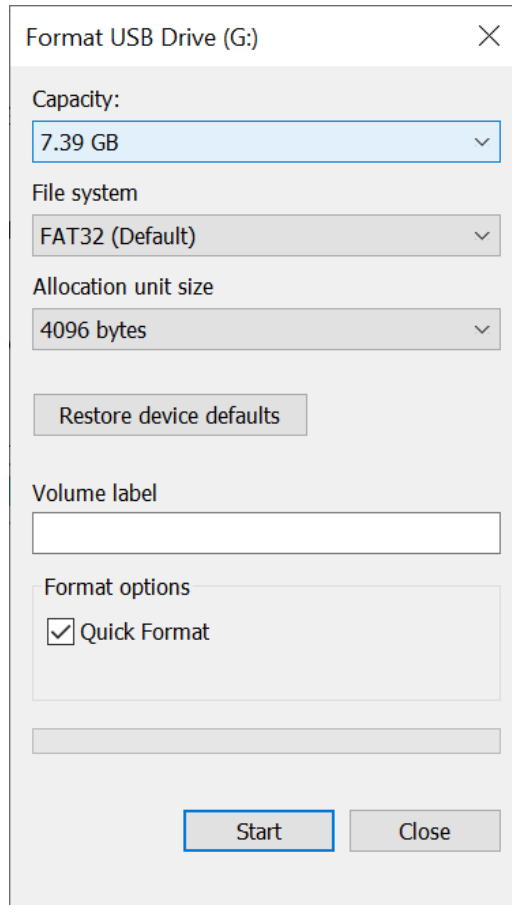

1. From the main menu, select **Maintenance > UPS report**.

2. Remove the cover for the USB port.

Rear View of the Front Door on UPS for Internal Batteries

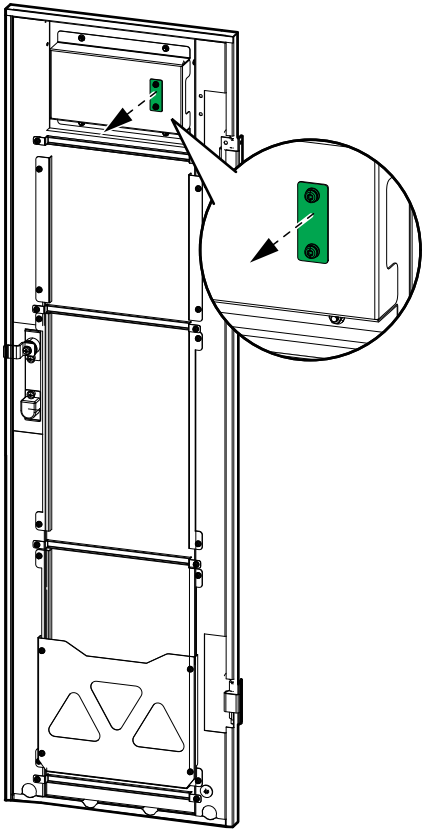

Rear View of the Front Door on UPS for External Batteries

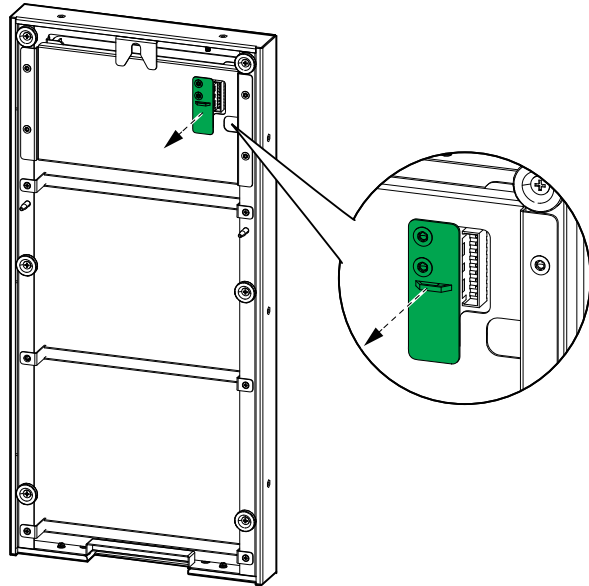

3. Insert your USB device in the USB port on the display.

Rear View of the Front Door on UPS for Internal Batteries

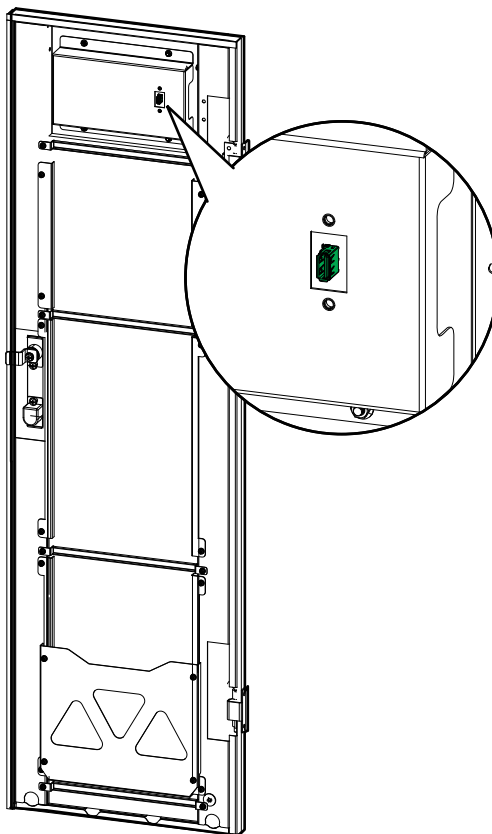

Rear View of the Front Door on UPS for External Batteries

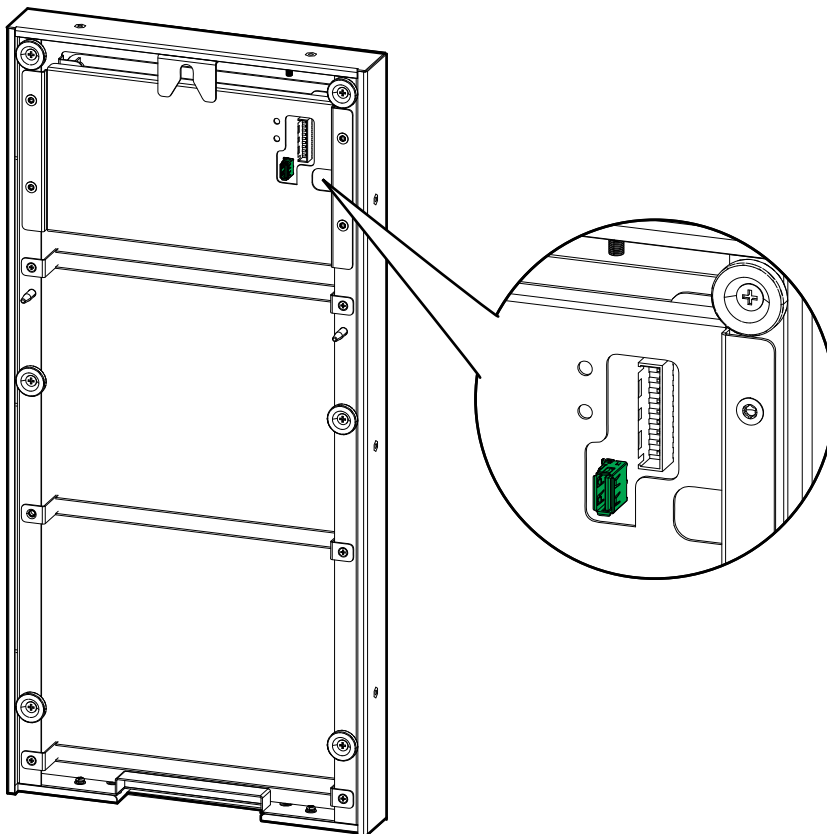

4. On the display, tap **Export**. When the display shows the message **Confirm to export UPS event logs**, tap **OK** to start the export process.
NOTE: Do not remove the USB device until the export process has finished.
5. The display will show the completion status with the message **Event dump successful** or **Event dump unsuccessful**. Tap **OK** to proceed.
6. Send the UPS event logs to Schneider Electric customer support.

Appendix: Switch/Circuit Breaker Model Details

UPS for External Batteries

3:1 UPS

	Model	Switch/Circuit Breaker Model (10)	Description	Switch or Circuit Breaker
10 kVA	UIB	A9S68432	32A 4P	Switch
	SSIB	A9S68263	63A 2P	Switch
	UOB	A9S68263	63A 2P	Switch
	MBB	A9S68263	63A 2P	Switch
15 kVA	UIB	A9S68440	40A 4P	Switch
	SSIB	A9S68280	80A 2P	Switch
	UOB	A9S68280	80A 2P	Switch
	MBB	A9S68280	80A 2P	Switch
20 kVA	UIB	A9S68463	63A 4P	Switch
	SSIB	A9S68292	125A 2P	Switch
	UOB	A9S68292	125A 2P	Switch
	MBB	A9S68292	125A 2P	Switch
30 kVA	UIB	A9S68480	80A 4P	Switch
	SSIB	A9S68480	80A 4P	Switch
	UOB	A9S68480	80A 4P	Switch
	MBB	A9S68480	80A 4P	Switch

3:3 UPS

	Model	Switch/Circuit Breaker Model (10)	Description	Switch or Circuit Breaker
10 kVA	UIB	A9S68432	32A 4P	Switch
	SSIB	A9S68432	32A 4P	Switch
	UOB	A9S68432	32A 4P	Switch
	MBB	A9S68432	32A 4P	Switch
15 kVA	UIB	A9S68440	40A 4P	Switch
	SSIB	A9S68440	40A 4P	Switch
	UOB	A9S68440	40A 4P	Switch
	MBB	A9S68440	40A 4P	Switch
20 kVA	UIB	A9S68463	63A 4P	Switch
	SSIB	A9S68463	63A 4P	Switch
	UOB	A9S68463	63A 4P	Switch
	MBB	A9S68463	63A 4P	Switch
30 kVA	UIB	A9S68480	80A 4P	Switch
	SSIB	A9S68480	80A 4P	Switch
	UOB	A9S68480	80A 4P	Switch
	MBB	A9S68480	80A 4P	Switch
40 kVA	UIB	A9S68492	125A 4P	Switch
	SSIB	A9S68492	125A 4P	Switch

(10) Available for ordering via the official website.

3:3 UPS (Continued)

	UOB	A9S68492	125A 4P	Switch
	MBB	A9S68492	125A 4P	Switch

Schneider Electric
35 rue Joseph Monier
92500 Rueil Malmaison
France

www.se.com



* 9 9 0 - 6 6 2 3 0 C - 0 0 1 *

As standards, specifications, and design change from time to time, please ask for confirmation of the information given in this publication.

© 2025 – 2026 Schneider Electric. All rights reserved.

990-66230C-001