

# CO<sub>2</sub> Sensor Module

## CO<sub>2</sub> sensor module for SE8000 Room Controllers

Out-of-the-box CO<sub>2</sub> sensor module to improve fresh air quality in schools, restaurants, offices and other small buildings.

### Product at a glance

Commercial spaces or small office buildings require a constant flow of fresh and conditioned air to create a healthy environment for people inside the building. The CO<sub>2</sub> sensor controls fresh air flow on the SE8600 Series model (IAQ feature), and displays the CO<sub>2</sub> sensors value on the SE8300 Series model. Use of CO<sub>2</sub> sensors with an energy efficiency program is one enabler for Building LEED, BREEAM and Green Star Certification.

- **Finish:** platinum EQC coating improves optic performance
- **Performance:** maintains high performance in varying air type environments
- **Reliability:** provides accurate and reliable carbon dioxide measurement
- **Conformity:** conforms to ASHRAE specifications for Green Building Standards.
- **Improved air quality:** achieves optimal ventilation and reduces stagnant air
- **Durability:** adapts to a multitude of environments
- **Affordable:** easily convince customers to invest in improved Indoor Air Quality (IAQ)
- **Convenience:** Install to any SE8000 Series Room Controller in minutes

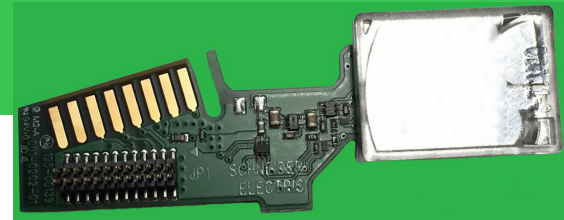

### Benefits

All CO<sub>2</sub> sensors are maintenance-free in normal environments thanks to the built-in self-correcting Automatic Baseline Correction (ABC) algorithm function. The sensors have a life expectancy of 15 years and do not require any calibration.

- Miniature size
- Requires no calibration
- Maintenance free
- Long term stability
- Low power consumption

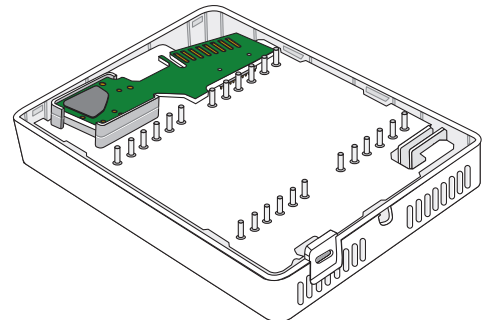

The convenience of an out-of-the-box module simplifies full implementation in minutes.

# CO<sub>2</sub> Sensor Module Overview

## Overview

The CO<sub>2</sub> sensor is an optional built-in easy-to-install module for the SE8000 Series Room Controllers. For HVAC applications, the CO<sub>2</sub> sensor can be used to monitor the indoor air quality, its data made available to interfacing devices on the Room Controller's data buses (i.e. BACnet), and control of fresh air inputs into the monitored zone. Typical site installations can include indoor zones with constant or periodic high concentrations of people, or in close proximity to commercial equipment generating high levels of CO<sub>2</sub> gas.

Since CO<sub>2</sub> gas is odorless and colorless making leakages difficult to detect, the CO<sub>2</sub> sensor ensures the wellbeing of personnel located in industrial zones where CO<sub>2</sub> generating equipment is installed.

Carbon dioxide measurement is required in many applications from building automation and greenhouses to life sciences and safety.

## Easy and worry free

The CO<sub>2</sub> sensor module is easy to install on any SE8000 Series Room Controller. The sensor is installed inside the Room Controller directly on the PC board via the pin connector, and requires no after service maintenance.

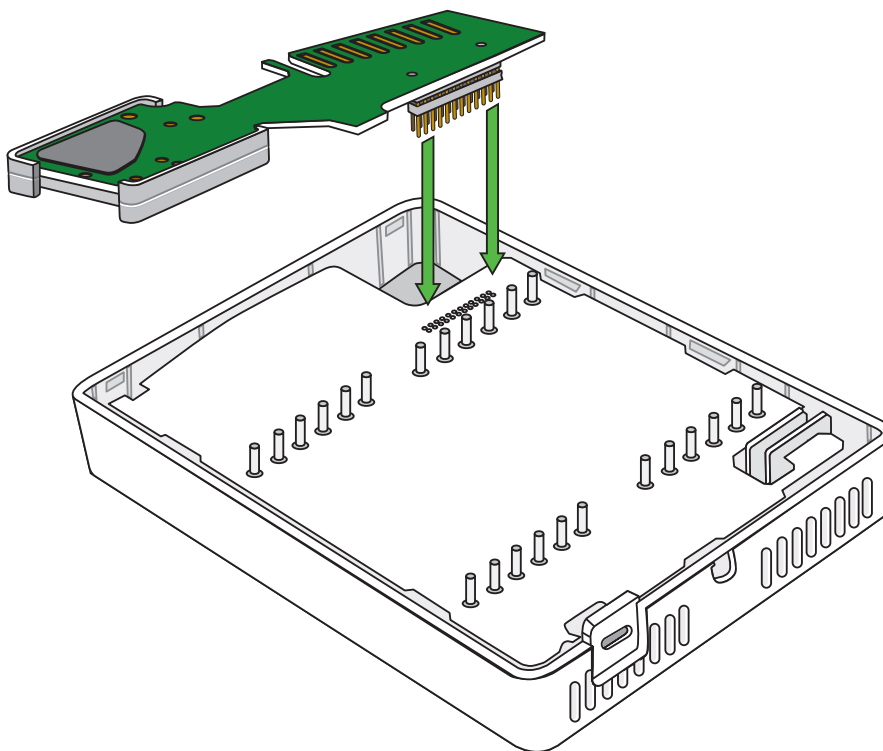

# Specifications

## Main Specifications for CO<sub>2</sub> Sensor

Item	Description
Target gas	CO <sub>2</sub>
Operating Principle	Non-dispersive infrared (NDIR)
Measurement range	400 - 10,000 ppm
Measurement interval	2 - 7 seconds
Accuracy	±30ppm +3% of reading (400 - 2,000 ppm range)
Pressure dependence	+ 1.6% reading per kPa deviation from normal pressure
Response time	Approximately 2 minutes
Operating temperature	23°F to 131°F (-5°C to 55°C) with excursions
Operating humidity	0 to 95% RH non-condensing
Storage temperature	-40°F to +158°F (-40°C to +70°C)
Dimensions	2.8in x 0.99in x 0.32in (71mm x 25.1mm x 8.2mm)
Weight	0.3oz (8g)
Power supply	3.4V to 4.5V
Power consumption	300 mA peak (28 mA average)
Life expectancy	15+ years
Compliance	Emission: EN 55022:2010 Class A Immunity: EN 55024:2010 RoHS directive 2011/65/EU
Internal Serial Communications between Sensor and Room Controller	UART, Modbus protocol
Maintenance	Maintenance-free

## Ordering Information

### Part number

VCM8001V5045

### Firmware Version

The Room Controller must be running Firmware version 2.0 or greater (starting with shipment of products with date code 1842 or later) to activate the functionality of the CO<sub>2</sub> sensor module. The CO<sub>2</sub> sensor module will not function with any Firmware version below 2.0. Make sure to download the latest Firmware version from The Exchange before installing the CO<sub>2</sub> sensor module.

### Room Controller Input Power

Usage of the CO<sub>2</sub> sensor module within the Room Controller draws additional power. It is recommended when using the CO<sub>2</sub> sensor module, the site transformer be capable to accommodate the additional power consumption. Room Controller power consumption of 12 VA is required.